

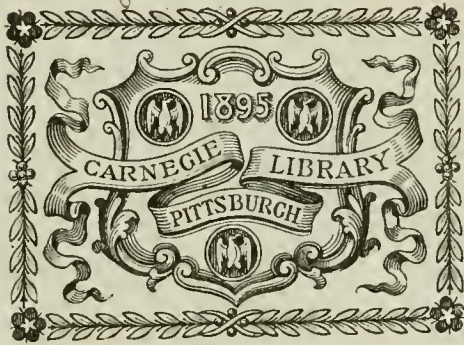

Class 9.2625.605 Book 5015. V.4



PRESENTED BY

Mr Andrew Carnegie.









THE  
STREET RAILWAY  
REVIEW

INDEX TO VOLUME IV

1894

CHICAGO  
WINDSOR & KENFIELD, PUBLISHERS  
269 DEARBORN STREET

# INDEX.

Articles marked "\*" are illustrated.

## EDITORIAL:

Accidents	744
Accident Insurance	390
Addressing Passengers	390
Advertising	389
Amalgamated Association of Street Railway Employes	453
Arrest of Train Crews	324
Artesian Well Power	2
Baltimore Fender Ordinance	619
Baltimore Fender Report	678
Baltimore Ordinances	389
Bellew's Prophecy	1
Boarding Cars	260; 741
Boyd, James	617
Brakes	130
Bribery by Supply Companies	743
Bridges, Occupancy by Street Rail- ways	65
Brooklyn Daily Papers Howl	195
Brooklyn Trolleys	323
Business Outlook	197; 259
Cairo, Egypt, Tramways	129; 389
Car Starters	195
Car Wiring	677
Change in Paying Fare	67
Chicago Electric Franchises	262
Children on Streets	129
Comparison of Traction Methods	130
Complaints	743
Conduit Railways	197; 744
Construction of Interurbans	677
Construction Work for 1894	2
Convention at Atlanta	453; 517
Convention Dates	517
Convention Exhibits	678
Convention Papers and Reports	66
Damage Suits	196
Death from Trolley Circuit	325
Decline in Prices	323
Delays on Cable Roads	259
Dirty Rails	742
Duties on Street Railway Material	742
Education of Public to Ride	260
Ejection of Passenger	323
Electrocution	743
Electrolysis	259
English Information	742
Epidemic among English Horses	195
Fare Boxes vs. Conductors	619
Fares in Europe and America	453
Fenders	744
Franchises	741-742
Gas Motors	741
Gates for Platforms	453
Glasgow Municipal Tramways	454
Greathead Underground System	65
Guard Wires	453; 677
Heating by Electricity	618
Hitching on Ordinance in Chicago	1
Home-made Engineering	518
House Moving Across Tracks	1

## EDITORIAL:

Indianapolis Wages	453
Interurban and Rural Railways	617; 741
Interurban Railways	1; 261; 322; 617
Insurance	66; 130; 195; 324; 454
Investments and the Crisis	260
Kansas City Consolidation	260
Knoxville Aerial Railway	130
Licensing Motormen	3
Lincoln, Neb., Insurance Inspec- tion	455
Mail, Express and Freight Service	618
Mail Service for Electric Road	391
Manslaughter by Motormen	618
Metropolitan Elevated Road, Chi- cago	389
Metropolitan Traction Prize	2; 66
Midwinter Fair	195
Movable Sidewalk System	259
Moving Houses Across Tracks	1
Municipal Ownership	129; 195; 196; 454
New York Rapid Transit	741
Obstruction of Tracks	65
Ohio Legislation	323
Omaha, Levy on Cars at	390
Open and Closed Car Seasons	324
Operating Expenses	517; 677
Our Third Birthday	1
Party Trains	195
Patent Parasites	679
Patent Litigation	390; 617
Paving to Rails	679
Pennsylvania Legislation	742
Philadelphia Accidents	454
Philadelphia Papers and the Trolley	454
Power House Department	517
Published Descriptions of Appli- cances	261
Railway Strike	391
Richardson, William	2
Safety Precautions	390
St. Louis <i>Republic</i> on the Trolley	518
San Francisco Accident	129
Seats for Modern Cars	617
Series-parallel Control	742
Special Cars	677
Speed and Economy	678
Speed Ordinances	65; 196; 323; 390
Standards for Street Railways	618
Street Railway Stocks	617
Storage Batteries	619
Storage Battery at Birmingham	129
Strike at Brooklyn	325
Strike at San Antonio	518
Strike at Toledo, O.	260
Strike at Youngstown, O.	196
Strikes	617
Summer Riding	259
Sunday Work	742
Supply Manufacturers in the South	518
Surface and Elevated Roads	1
Tampering with Wires	741

## EDITORIAL:

Taxation of Stock	455
Three-Wire System	455
Tool Cars	1
Transfers	453
Travel Created by Electricity	677
Trial Trips	743
Trolley Wire Height at Steam Crossings	389
Two Sides of Management	618
Vestibules	743
Vestibule Law in Minnesota	389
Wages at Indianapolis and Savan- nah	453
Wages Paid in Missouri	65
Welding Rail Joints	259; 324
Welding Track at St. Louis	65
Winter Operation	741
Withdrawal from the Association	678

## A.

A B C of Electrical Students	293
Accident, A Detroit*	419
Accidental Deaths in Cincinnati	44
Accidental Ride in a Wheel*	334
Accident, A San Francisco*	109-110
Accident at Peoria, Standpipe*	302
Accident Blanks of the Victoria Electric Railway & Lighting Company	377-378
Accident Insurance	280-281
Accident Insurance of Street Railway Companies	405-406
Accidents, Cable, in Great Britain	34
Accidents on Trolley Lines	79
Accidents, Personal Injury, and the Management of Employes with Reference Thereto	774-775-776
Accident: Trolley Kills a Boy*	326
Accident, Trolley Wheel*	96
Accounts for Street Railways, A Stand- ard Form for	648-649-650-651-652
Acme Car Jack, The*	290
Adams, W. F. (Portrait)	106
Advertisement, A Novel*	491
Advertising in Street Cars	745
Advertising Points of Interest*	698
Aerial Cable in England*	687
Aerial Railway at Gibraltar*	215
Aerial Ropeway, Another	556
Aerodromic System of Transportation*	214
Air Line, A Mexican	431
Allen, J. H. (Portrait)	554
Allentown & Bethlehem Rapid Transit Company's "Central Park"	404
Allentown & Bethlehem Traction Com- pany's Menagerie	352
Allen, William Henry (Obituary)	125
Alley L Election, Chicago	3
Alderman's Dream, The	570
Aluminum Register, An*	61
American Car Company New Agencies	226
American Electrical Works	563



**AMERICAN STREET RAILWAY ASSOCIATION:**

Meeting of Executive Committee . . . 109  
 Arrangements for Delegates and Exhibits at Atlanta Convention\* . . . 190-191  
 Applications for Exhibit Space at Atlanta . . . 327  
 Information Requested for Paper on "Mail, Express and Freight Service," to be Read at Atlanta . . . 402  
 Program and Plan of Entertainment at Atlanta Convention . . . 531-532  
 Officers and Executive Committee, 1893 . . . 533  
 Local Committee of Arrangements at Atlanta Convention . . . 551-552-553-554-555  
 Headquarters at Aragon Hotel\* . . . 557-558  
 Thirteenth Annual Convention:  
 Address of Welcome . . . 581  
 President Payne's Response . . . 582  
 President's Address . . . 582-583  
 Report of the Executive Committee . . . 583-584-585  
 Report on the Best Method of Treating Accidents and Complaints . . . 585-586  
 Reception by Capital City Club . . . 587  
 Report on T Rail Track Construction of the Terre Haute Electric Railway . . . 587-588-589-590-591  
 Paper on Power Brakes vs. Hand Brakes . . . 597-598-599-600-601  
 Report on T Rail in Paved Streets . . . 601-602-603  
 Report on City and Suburban Electric Railways . . . 603-604-605-606  
 Special Paper on Destructive Arcing of 500-volt Fuses . . . 606-607  
 Special Paper on the Use of the Booster on Electric Railway Circuits . . . 607-608-609-610  
 Special Paper on Taxation . . . 610-645-646-647  
 Abstract of Paper on Brake Shoes . . . 621-622-623-624-625  
 Report on Mail, Express and Freight Service on Street Railroads . . . 626-627-628  
 Report on a Standard Form for Accounts for Street Railways . . . 648-649-650-651-652  
 Report on Transfers on Street Railways . . . 670-671  
 Election of Officers . . . 592  
 The Barbecue . . . 592-593  
 Exhibits . . . 594-595-596; 663-664-665-666-667-668-669  
 Lesson of the Exhibits . . . 669-670  
 Convention Notes . . . 672-673

Ames Direct Connected Engine\* . . . 229  
 Ames Register, The\* . . . 112  
 Ames Tandem Compound Engine\* . . . 776-777  
 Ammeter Record, Cleveland Electric Railway\* . . . 335  
 Anderson, A. A. (Portrait) . . . 95  
 Anderson Overhead Special Work\* . . . 658  
 Andrews, Payson K. (Portrait) . . . 226

Andrews, Payson K. (Obituary and Portrait) . . . 521  
 Another Lie Nailed . . . 489  
 Arcing of 500-volt Fuses, Destructive . . . 606-607  
 Armature Star, Largest in the World\* . . . 431  
 Arnold System of Engine and Generator Coupling\* . . . 354  
 Artesian Well District of South Dakota . . . 79  
 Artesian Well Power, South Dakota\* . . . 4-5  
 Asphalt Paving to T Rail\* . . . 228  
 A Tip (Verse) . . . 124  
 Atlanta, En Route to . . . 529-530  
 Atlanta, Georgia\* . . . 533-534-535-536-537-538-539-540  
 Atlanta, How to Reach . . . 489  
 Atlanta's New Road . . . 128  
 Atlanta's Street Railways\* . . . 541-542-543-544-545-546-547-548-549-550-704

**B.**

Babcock, Geo. H. (Obituary and Portrait) . . . 62  
 Baby at Leschi Park, Seattle\* . . . 411  
 Badge, A Car\* . . . 25  
 Baggage System, Niagara Falls, Park & River Railway\* . . . 499  
 Ball Direct Connected Engine, The\* . . . 142  
 Ball Vertical Engine, The New\* . . . 564  
 Baltimore, Municipal Oppression at . . . 90  
 Bangor, Me., Three-wire System at\* . . . 513  
 Banti, Angelo, Dr. (Portrait) . . . 492  
 Barclay, J. L. (Obituary) . . . 255  
 Barmen Mountain Railway Company\* . . . 474-475  
 Barney & Smith Manufacturing Company\* . . . 100  
 Barney & Smith Truck\* . . . 361  
 Barns, Heating by Hot Air\* . . . 293  
 Barrow Brake, The\* . . . 96  
 Barrows Elevated Road\* . . . 280  
 Batavia Bicycle Railway, The\* . . . 273  
 Battery, Performance of the Globe Storage . . . 320  
 Battery, The Hess Storage\* . . . 14  
 Bean, W. Worth, Shoots an Alderman . . . 524  
 Beardsley's Insulating Oil Paper . . . 43  
 Beaver & Ellwood Railroad . . . 428  
 Beaver Valley Traction Company's Ball Park\* . . . 355  
 Belting, Patent Grooved Sable Rawhide\* . . . 442  
 Belting, Walton's Link\* . . . 85  
 Belt Splicing . . . 347  
 Bemis Truck, Philadelphia Traction Company Adopts . . . 19  
 Beveled Rails, Chicago City Railway\* . . . 566-567  
 Bicycle Railway, Boynton's, for Boston\* . . . 95  
 Bicycle Railways, Reincarnation of Elevated\* . . . 352  
 Bicycle Railway, The Batavia\* . . . 273  
 Bidwell Trolley Head, The\* . . . 108  
 Blakistone's Combination Car Fenders\* . . . 755-756  
 Block Signal at Sioux City\* . . . 700  
 Block Signal for Single Track Roads\* . . . 189  
 Block Signals at Buffalo\* . . . 166  
 Boiler of Atlas Engine Works\* . . . 704  
 Boiler, The Caldwell Standard Water Tube\* . . . 194  
 Bonding Caps, Steel\* . . . 228  
 Bonding Chuck, A\* . . . 280

Bonding Devices, The Hoffman\* . . . 496  
 Bonding, J. H. Vail on . . . 213  
 Bond, Robison's Rail\* . . . 747  
 Bond, The Technie Improved Rail\* . . . 571  
 Boomer, L. S. (Portrait) . . . 687  
 Booster on Electric Railway Circuits . . . 607-608-609-610  
 Boston's Subway Scheme . . . 42  
 Bowen, M. K. (Portrait) . . . 456  
 Bowie, Oden (Obituary and Portrait) . . . 756  
 Bracey's Improved Railroad Spike\* . . . 282  
 Brackets, Some New Creaghead Flexible Pole\* . . . 562  
 Brake, A Safety Clutch\* . . . 120  
 Brake, Genett Air\* . . . 321; 640  
 Brake, St. Louis Electric\* . . . 802  
 Brake, San Francisco Slot\* . . . 334-335  
 Brake Shoes . . . 621-622-623-624-625  
 Brake Shoes, Composite\* . . . 676  
 Brake Shoe, Wharton's Wooden Faced\* . . . 347  
 Brakes in Action, Genett\* . . . 707  
 Brakes on Electric Roads . . . 84-85  
 Brake, Sperry on the Electric\* . . . 641-642-643  
 Brakes, Power vs. Hand\* . . . 597-598-599-600-601  
 Brake, Tandem\* . . . 636  
 Brake, The Barrow\* . . . 96  
 Brake, The Carter\* . . . 403  
 Brake, The Lawrence Track\* . . . 241  
 Brake, The Pneumatic\* . . . 223  
 Brake Shoe, The Schoen\* . . . 85  
 Brake, The Sperry Electric, in Chicago\* . . . 497-498  
 Brakes, The Value of Air . . . 402  
 Brake, The Winters Car\* . . . 61  
 Breed Tower Wagon, The\* . . . 88  
 Brick Filler, Bruner's\* . . . 352  
 Brick for T Rails, Special Form\* . . . 210  
 Brick, Granite and Cedar Pavement\* . . . 764  
 Brick Liner for T Rail, Peoria\* . . . 419  
 Brick Paving . . . 335-336  
 Brick Paving at Louisville, Ky.\* . . . 357  
 Brick Paving to T Rail\* . . . 32  
 Bridge at Halsted Street, Chicago\* . . . 219-220  
 Bridge from Staten Island to New Jersey . . . 46  
 Bridge of Metropolitan L at Chicago\* . . . 209  
 Bridge over Harlem River . . . 151  
 Bridge, The Gagnier-Griffin Suspension . . . 255  
 Bridge, The Longest Swing\* . . . 356  
 Bridge, Tower, London\* . . . 452  
 Brigantine Transit Company . . . 652  
 Bristol, England, Tramways, The\* . . . 294-295  
 Bristol Recording Voltmeter\* . . . 37  
 Brooklyn Bridge . . . 19  
 Brooklyn Bridge Cable Road Electric Light . . . 764  
 Brooklyn L and the Electrics . . . 40  
 Brooklyn Railway Consolidations . . . 215  
 Broom, A Revolving Track\* . . . 490  
 Brother-in-Law, The\* . . . 632  
 Brott Elevated Electric Railway\* . . . 336-337  
 Brown, H. P. (Portrait) . . . 355  
 Brown, N. W. L. (Portrait) . . . 554  
 Brown, R. C. (Portrait) . . . 319  
 Bruner's Brick Filler\* . . . 352  
 Bruning, J. H. (Portrait) . . . 460  
 Brush Holder, Adjustable Track\* . . . 727  
 Brush, Solar Carbon and Metal\* . . . 337  
 Bucking Snow\* . . . 11-12-13  
 Buffalo Street Railway Company's Earnings . . . 347  
 Bullen, R. D. (Portrait) . . . 554  
 Bus, Another London\* . . . 228  
 Bushnell, M. B. (Portrait) . . . 661

## C

Cable Accidents in Great Britain	34
Cable and Electricity Compared	785
Cable Railway on the Ice*	387 388
Cable Road Patent Void, A	213
Cables, Comparative Life of English	708
Cables, Gripping, by Compressed Air*	561
Cable to Electricity, From	70
Cab-omnibus, A*	342
Caldwell, C. C. (Portrait)	267
Caldwell Standard Water Tube Boiler, The*	194
California Midwinter Fair*	257
Canal Boats by Trolley in France	89
Canal, Erie, Electric Power on	33
Canal Trolley Commission, Report of	124
Canterbury, J. B. (Portrait)	717
Car, A Haunted	31
Card Street Railway Motor, The*	366 367
Car Elevator*	41
Car Fender	7
Cargill, W. W. (Portrait)	717
Car House of Lafayette Street Railway*	277
Car House, Wheeling Railway Com- pany*	349 350
Car, Open and Closed*	631
Car Shed, New Orleans and Carrollton Railroad*	34
Cars in San Francisco, Funeral*	6
Cars, Two Handsome*	684
Car Telescopes a Barn	124
Carter Brake, The*	403
Car, The C. D. Morse Company's*	255
Car, The Lalla Rookh of the Toronto and Scarboro*	635 636
Cast-Welding Rail Joints*	749 750 751 752
Cayadutta Electric Railroad Company*	237
Cement for Steam Pipes	414
Center Poles on Residence Streets*	766-767
Chalk, S. A. (Portrait)	783
Challenger, C. (Portrait)	295
Channel Pin, Another*	151
Chapman, J. R. (Portrait)	532
Chapman's Motor Disconnecter*	784 785
Charles Scott Spring Company	718
Cheap Riding, Result of	765
Chicago Alley L Election	3
Chicago City Railway, Annual Report	79
Chicago City Railway, Beveled Rails on the*	566 567
Chicago City Railway, Electric Power on the*	456-457-458-459
Chicago City Railway Employees (Group Portrait)	153
Chicago City Railway Mutual Aid So- ciety	760
Chicago City Railway System, Map of*	458
Chicago General Railway Plant*725	726-727
Chicago General Railway Prize Contest	319
Chicago General R'y Prizes Awarded	507
Chicago General Railway Traffic	516
Chicago Lake Street Elevated Election	512
Chicago Lake Street L to Electrify	760
Chicago Lines, Proposed	735
Chicago L Roads Loop*	748
Chicago, Progress of Construction in	739
Chicago Roads, Annual Meetings of	48
Chicago Track Elevation*	718
Chicago Trolley Base, The*	125
Chimney at Toronto, Tall, *	472
China Tramway, A Southwest*	430
Cicott, Frank N. (Portrait)	204
Cincinnati, Newport & Covington Rail- way*	331 332 333
Circle to the Right	358
Citizens' Street Railway Franchise, In- dianapolis	485 486 487 488
Citizens' Traction Company, Pittsburg, Annual Report	80
City and Suburban Electric Railways, .....	603 604 605 606
Clark, S. A. (Portrait)	783
Cleveland City Railway Palace Car*	724
Cleveland City Railway Park*	10 11
Cleveland Electric Railway Fire	211
Cochrane's Reliable Heater*	806
Collars, The Giant Safety*	353
Collision in Baltimore*	344
Columbia Magazine Cast Iron Street Car Heater*	451
Columbus Method, The	89
Common Sense Sand Box, The*	194
Commonwealers as an Attraction	512
Competition in New York	277
Competition of Electric and Steam R'ds	491
Competition of Electric Roads	602
Competition of Trolleys and Elevated Road at Brooklyn	347
Composite Brake Shoes*	676
Compressed Air at Westfield, Mass.	402 721
Compressed Air System, Conti*	721
Conductors, Rewards to	19
Conductors, Would-be	345
Conduit at Washington, The King*	406
Conduit, Crosby & Reitmeyer*	168
Conduit Rail'd, An Ancient Pneumatic	355
Conduit Road, Lenox Avenue, New York*	787
Conduit, The Goodhand*	566
Conduit, The Lawrence*	282
Conduit, The Petersen*	185
Connecticut Street Railway Associat'n	258
Consolidated Market Street Cable Rail- way Mortgage	151
Consolidation, Sioux City	23
Construction and Operation of Small Street Railways	683 684
Conti Compressed Air System*	721
Contributory Negligence*	58
Control, Comparison of Rheostat and Series—Parallel*	685 686
Controller, Westinghouse*	307 308
Convention Memories	738
Corrigan, Thomas (Obituary)	189
Cortland Omnibus & Cab Company	567
Cost of Operating Beaver Valley Traction Company	653
Cost of Steam and Electricity for the Operation of Railways	233 234
Cost of Steam, Compressed Air and Electricity for the Operation of Rail- roads	230-231-232
Cost per Car Mile at Little Rock	144
Cradock Rope Record	370
Cradock Ropes	490
Cradock Ropes Break All Records*	42
Crawford Fender, The*	127
Crawford, R. A. (Portrait)	127
Craghead Flexible Pole Brackets*	562
Creating Travel, A New Method of	305
Creating Travel, Novel Method of	771
Crosby & Reitmeyer Conduit*	168
Cross Over, Insulated Adjustable*	735
Crowding in Cars	343 344
Crown Glass Oil Cup, The*	25
Curtis Motors for Brooklyn	194
Curve at Cincinnati, A Peculiar*	689
Curves and Car Trucks*	30 31
Cut-out, Mayo's Automatic Trolley*	45

## D

Daily Press, From the	631
-----------------------	-----

Daily Press, Unreliability of	215
Dalzell, John H. (Obituary and Por- trait)	388
Damage Suits, Examination of Injuries in	153 154
Daniels' Steel Tie, The*	568
Darrach Fender, The*	167
Darr, W. (Portrait)	538
Davis Shades and Holders, The*	192
Davis Tower Wagon*	43
Day, Everett K. (Portrait)	19
Day of Judgment	3
Deadly Locomotive, The	266
Deadly Trolley, False Report from the	724
Declined with Thanks	343
Dederick's Fender*	428
Depot, Elevated Railway Terminal*	90-91
De Ronde, Frank S. (Portrait)	85
De Ronde, Frank S. Married	654
De Steese, H. (Portrait)	27
Detroit Citizens' Railway Sale	576
Detroit Railway Company	752
Detroit, Situation in	471
Devemy, Charles (Portrait)	172
Devenny, James L. (Portrait)	172
Devemy, John C. (Portrait)	172
De Witt, G. H. (Portrait)	302
Dexter, Allen S. (Portrait)	500
Did Not Want to Sober Up	346
Didn't Wear Hoops	770
Died in a Good Cause	506
Disconnecter for Motors*	784 785
District of Columbia Railroad Bill	73
Doane Lightning Arrester*	220
Dodge Clutch Shifter, The*	56
Dodge, Wallace H. (Obituary)	521
Dog with a Pass*	40
Draw Bar; Van Dorn Automatic*	676
Dublin, Ireland, United Tramways Re- port	137
Dublin, New Electric Line in	779
Du Bois, Pa., Vestibules at*	44
Dubuque, Iowa, Skating Rink	777
Duncker Trolley Head, The*	96

## E

Early Days of Street Railroad	482-483
East Broadway & Battery Election	73
Eaton Car Fender*	620
Echoes from the Trade	57 to 59; 121 to 123; 186, 187; 251 to 254; 315 to 319; 379 to 382; 445 to 448; 509 to 511; 573 to 576; 736 to 738; 808 ..... to 810
Eddy Multipolar Generator, The*	47
Edgar, H. T. (Portrait)	537
Edison's New Electrical Railway*	120
Educating Motormen, An Aid in*	262
Educational Adjunct, As an*	118
Edwards, B. E. (Portrait)	717
Electric Cars as Newspaper Carriers	220
Electric Car, The* (Verse)	152
Electricity vs. Steam	234
Electric Line, An	176
Electric Power vs. Steam	415
Electric Railway as a Philanthropist	339
Electric Railway, Light & Power Com- pany, Anaconda, Mont*	162-163-164
Electric Traction, Evolution of	711 712 713
Electrolysis at St. Louis, Experiments with	356
Electrolysis, Farnham on	306
Electrolysis, How to Cure	152
Electrolysis, How to Prevent*	559 560 561
Electrolysis of Iron Pipes	449-450

Electrolysis of Pipes at Milwaukee\*... 16  
 Electrolysis of Potatoes.....425  
 Elevated Electric Railway, Johnson and  
 Brott Systems\*.....336 337  
 Elevation of Chicago Tracks\*.....718  
 Elevator, Electric Car\*..... 41  
 Elkhart, Ind., Street Railway Pur-  
 chased.....472  
 Elkins, William L.....707  
 Elliott, Thomas (Portrait).....555  
 Ellis Car Company Fire.....322  
 Ellis Company's Selling Agents\*.....687  
 Ellis, Harvey (Portrait).....508  
 Ellis Manufacturing Company.....508  
 Elwood, Ind., Explosion\*..... 779  
 Emergency and Wreck Wagon Sys-  
 tems.....Part I, 393, 394; Part II, 493  
 Empire State Radial Truck, The... ..565  
 Employes' Convention.....658  
 Employes, Nest Egg for.....788  
 Engine, Ames Direct Connected\*.....229  
 Engine, Ames Tandem Compound\*...  
 .....776 777  
 Engine and Generator Coupling, Arnold  
 System\*.....354  
 Engine Ideal\*..... 36  
 Engine, Performance of a Triple Expan-  
 sion\*..... 24  
 Engines, High vs. Low Speed..... 68  
 Engines for Railway Work, High vs.  
 Low Speed.....184; 278 279  
 Engine, The Ball Directed Connected\*.142  
 Engine, The New Ball Vertical\*.....564  
 England, Electric Roads in..... 24  
 England, Electrics in.....345 346  
 England, Trolley Railways in.....157  
 English, Jr., James W. (Portrait).....552  
 English Roads Want Electricity..... 24  
 Erb, Louis M. (Portrait)..... 480  
 Erb, Newman (Portrait) .. ..480  
 Erie Canal, Electric Power on..... 33  
 Etiquette, Street Railway.....488  
 Enphrat's Guard and Screen Attach-  
 ments for Windows.....523  
 Eureka Sand Box\*.....810  
 Europe, Distribution of Electric Power  
 in.....295  
 Events of 1893, Leading Street Railway  
 .....15 16  
 Evolution of Electric Traction.711-712 713  
 Experiences of a Superintendent.....  
 Part II, 35; Part III, 102-103; Part  
 IV, 221-222; Part V, 283-284; Part  
 .....VI, 443-444  
 Explosion at Elwood, Ind.\*.....779  
 Explosion at North Chicago Street Rail-  
 road Company's Offices\*.....348  
 Exposure of a Professional Witness....155  
 Express and Freight at Hornellsville,  
 N. Y.\*.....343  
 Eyesight of Motormen, Testing.....327

**F**

Failure of Syracuse Consolidated Street  
 Railway Company..... 19  
 Fair Freezer Frozen Out, The (Verse).229  
 Falcon Fender, The\*.....211  
 Falk Trolley Head, The\*.....449  
 Family Outings.....481  
 Fare Box, The Sevey\*..... 86  
 Fares are Reduced in Keokuk, Ia.....694  
 Farming Purposes, Selling Power for\*.714  
 Far or Near Stops.....777  
 Fast Time on the Brigantine Road.....652  
 Feeder Panel, General Electric\*.....258  
 Feeders for Electric Railways, Graphic  
 Method of Locating\*.....158

Felder, Jr., T. B. (Portrait).....554  
 Fender\*.....151  
 Fender, A Feat of the Pflugst\*.....124 125  
 Fender, Blakistone's Combination\*.755 756  
 Fender, Car..... 7  
 Fender Committee, Report of Balti-  
 more's.....639 640  
 Fender, Dederick's\*.....428  
 Fender, Eaton Car\*.....620  
 Fender Humor.....727  
 Fender, Modemum Car\*.....762  
 Fender of the Toronto Railway, Stan-  
 dard\*.....692  
 Fender Ordinance, Baltimore\*.....660  
 Fender, Peckham's\* .. ..433  
 Fender, Requirements for a Car.....277  
 Fenders, A Few Facts on\*.....81 82 83  
 Fender Test, Robins.....354  
 Fender, The Crawford\*.....127  
 Fender, The Darrach\*.....167  
 Fender, The Falcon\*.....211  
 Fender, The Pittsburg-McGuire\*.....762  
 Fender, The Trauter\*.....273  
 Fender, Thomas' Life\*..... 295  
 Field, Arthur W. (Portrait).....284  
 Field, Arthur W., Married..... 383  
 Fillers for Paving, Osage Orange\*..... 210  
 Fire Apparatus on Electric Railways,  
 Transporting.....481  
 Fire Apparatus on Electric Roads.....428  
 Fire at Ann Arbor\*..... 94  
 Fire at Attleboro, Mass\*..... 62  
 Fire at Laconia, N. H.....327  
 Fire at New Orleans City & Lake Street  
 Railway Company Resort\*.....357  
 Fire at Pittsburg Car Barn.....760  
 Fire at Sacramento, Power House.....266  
 Fire at St. Louis.....207  
 Fire, Big, at Cincinnati.....108  
 Fire Destroys Ellis Car Company's  
 Plant.....322  
 Fire Destroys Siemens-Halske Factory  
 at Chicago\*.....464-465  
 Fire in Central Railway Barns at Peoria.465  
 Fire in Cleveland Electric Railway  
 Shops.....211  
 First Street Car Conductor.....788  
 Five Worries in the Life of a Con-  
 ductor\* (Verse).....488  
 Flings at New York.....691  
 Flirting along the Line.....334  
 Flirting on Street Cars..... 95  
 Flood in Chicago, A Youog.....567  
 Flood in Portland, Oregon\*.....392  
 Fonda, Johnstown & Gloversville Rail-  
 road\*.....235-236-237  
 Foreign Facts, 63; 183; 197; 298, 432; 763  
 Fosdick, R. A. (Portrait).....258  
 Foster, E. C. (Portrait).....182; 603  
 Fourth of July at Champaign, Ill\*.....418  
 France, Cost of Traction in.....156  
 Franklin Institute Medals..... 16  
 Free Rides for the Unfortunate.....362  
 Freight and Express at Hornellsville,  
 N. Y.\*.....343  
 Freight Car, The Spokane\*.....448  
 Freight Line, An Electric.....142  
 Freight Lines, Street Railway\*.363 364 365  
 Frenyear, T. C. (Portrait).....237  
 From the Daily Press.....631  
 Fuel Oil at Aurora, Ill.....348  
 Fuel, Petroleum Brick.....289  
 Fulton Imperial Truck\*..... 60  
 Fulton Truck & Foundry Company.661 662  
 Funeral Car Company.....465  
 Funeral Cars in San Francisco\*..... 6

Fuses, Fifty-ampere Car.....570  
 Fuses, Underwriters' Rules Covering\*  
 .....702 703 704

**G**

Gagnier-Griffin Suspension Bridge, The  
 .....255  
 Galveston, Texas, Street Railway Com-  
 pany.....348  
 Game, A New.....463  
 Garton, W. R. (Portrait).....510  
 Gas Motors in Europe.....567 568  
 Gas Motors in Germany.....343  
 Gate, The Pitt Folding\*.....107 108  
 Gave Baby a Ride\*.....692  
 Gaynor Trolley Base, The\*.....164  
 Gearing, Worm.....337  
 General Electric Company, Chicago  
 Office of the.....126  
 General Electric Feeder Panel\*.....258  
 General Electric Generator Panel\*.....507  
 General Electric Nut Lock\*.....210  
 Generators, The Large Walker\*.....473  
 Generators, The Mather\*.....514  
 Generator, The Eddy Multipolar\*..... 47  
 Genett Air Brake Company\*.....640  
 Genett Air Brake, The New\*.....321  
 Genett Brakes in Action\*.....707  
 Genoa, Long Distance Transmission at\*  
 .....138-139-140-141  
 Gettysburg Battlefield Railroad.....417; 761  
 Gettysburg Battlefield Road Receiver..142  
 Gettysburg Electric Railway Injunction.365  
 Giant Safety Collars, The\*.....353  
 Giles, A. F. (Portrait).....555  
 Giller, Henry W. (Obituary)..... 62  
 Girl in Blue-Tign.....  
 Give Me a Mate.....  
 Glasgow Municipal Tramways.....594  
 Glasgow Tramway Management.....563  
 Glenn, T. K. (Portrait).....552  
 Glenn, W. H. (Portrait).....552  
 Globe Storage Battery in Chicago, Per-  
 formance of the.....320  
 Goodall, E. M. (Portrait)..... 19  
 Goodhand Conduit, The\*.....566  
 Good if Not True.....378  
 Goodrich, E. S. (Portrait).....532  
 Goodrich, William H. (Obituary).....552  
 Gosben, Ind., Street Railway Purchased.472  
 Graham's Truck\*..... 61  
 Grandma's Poem (Verse)\*.....351  
 Grand Rapids Resorts\*.....420  
 Graphic Method of Superintendency,  
 A\*.....135-136  
 Gripman, Song of the (Verse).....347  
 Ground Return, Notes on the.....708  
 Guard Wires.....706-707

**H**

Haas, A. F. (Portrait)..... 10  
 Had a Heap to Learn.....632  
 Had a Real Grievance.....727  
 Haight & Clark Sleet Trolley, The\*..... 73  
 Half Fares.....  
 69; 134; 205, 206; 296, 297; 384; 434-  
 .....435; 462; 522 523; 719 720; 768 769  
 Half Fares, Handling.....471 472  
 Hamilton, Grimsby & Beamsville Elec-  
 tric Railway.....239  
 Hamilton Radial Railway\*.....786  
 Hancock, Joel C. (Portrait).....508  
 Hansell Truck, The\*.....508  
 Harrison, Russell B. (Portrait).....613  
 Harthan Tower Wagons, The\*.....227  
 Hart, W. J. (Portrait)..... 333  
 Has Gone to Kansas City.....699

Has Plenty of Company	218
Hathaway, W. A. (Portrait)	503
Haunted Car, A	31
Haycox, W. E. (Portrait)	661
Hazelrigg, S. F. (Portrait)	95
Headlights, Electric*	569-570
Heater, Cochrane's Reliable*	810
Heater, Columbia Magazine Cast Iron Car*	451
Heaters, Electric, for the Metropolitan L. Chicago*	756
Heaters, Large Order for Electric Car	556
Heating, Electric Car*	466-467
Heilmann Electric System	524
Heilmann Locomotive, The*	212-213
Hendersonville Street Railway Company	348
Hendrie, Strathearn (Portrait)	601
Hercules Trolley Clamp*	320
Hess Storage Battery, The*	14
High vs. Low Speed Engines for Railway Work	68
Hildreth, J. H. (Portrait)	494
Hill Automatic Rheostat Switch, The*	433
Hill, Robert (Portrait)	456
Hill Switch, The New W. S.	334
His Busy Day	427
His Feeling (Verse)	89
Hitching on	3
Hitching-on Ordinance	150
Hitching-on Ordinance at Allegheny	240
Hobson, S. A. (Portrait)	103
Hoffman Bonding Devices, The*	496
Hoffman Casting Process at St. Louis	682
Holbert Sand Box*	32
Hollow Rails	349
Holly, Birdsil (Obituary)	322
Homes, Conway F. (Portrait)	308
Honolulu Street Railway*	701
Hot Air System in the Calumet Barns*	293
House Mover at Lincoln, Neb., How They Handle the	652
House Moving Ordinance, Youngstown, O.	255
Houston, Tex., Parade at*	46
How Is This for a Kick?	416
How It will Be A. D. 2000	415
How They Broke Him in	562
Hubley Trolley Harp, The*	562
Hurt, C. D., Dr. (Portrait)	553
Hurt, H. N. (Portrait)	551
Hurt, Joel (Portrait)	551; 593

## I

Ice and Sleet Cutting Trolley Wheels*	579
Ideal Elevated Rapid Transit	472
Ideal Engine*	36
Illuminated Car Sign*	193
In a Street Car (Verse)	499
Incline Railway at Lawrence, Kan.	156-157
Incline Railway, Stanserhorn*	78-79
Independent Trolley, The*	358
Indiana Electric Railway Company, Elkhart	620
Indianapolis Street Railway, Plots against	47
Inducing Travel at Ottumwa	256
Information Wanted	499
Inman, S. M. (Portrait)	555
Inspection, Motor*	328
Insulating Oil Paper, Beardsley's	43
Insurance, Accident	280-281
Insurance Laboratory, Proposed	425
Insurance Rates and Power House Construction	149-150
Insurance of Street Railway Companies, Accident	404-406

Insurance Swindler	108
International Tramway Union, The	491
Interurban Service, Trains for*	267-268-269
Interurbans in the Wyoming Valley*	427
Intramural Electric Elevated Railway, Operating Expenses of the*	368-369-370
Ithaca Street Railway Company*	709-710

## J

Jaastad, A. U. (Portrait)	799
Jackson & Sharp New Sprinkler*	691
Jackson, Henry, Capt. (Portrait)	553
Jack, The Acme Car*	290
Jack, The Stilwell Railroad*	353
Jamestown Street Railway Park	11
Japanese Electrical Paper	773
Japanese Rack Railway*	770
Jewell Trolley Sling*	658
Jewell, W. S. (Portrait)	185
Johnson Elevated Electric Railway	336-337
Johnson-Lundell Electric Railway*	426-427
Johnson Works at Lorain, The New	419
Joke, That Old	33
Jolt at Albany, N. Y., A Big	566

## K

Kansas City Consolidation*	308
Keep the Trolley on the Wire (Verse)	94; 556
Kelley, W. M. (Portrait)	555
Kenfield-Sweeney	684
Kensington & Streatham Cable Railway*	86
Kickers, "Amber's" Sermon on	155
Killing Weeds by Electricity	698
King Conduit at Washington, The*	406
Kingston, W. W. (Portrait)	552
Knapp Swivel Trolley Fork, The*	45
"Knocking Down"	344-345
Knox, G. W. (Portrait)	456
Knoxville's Suspended Railway*	74-75
Kohler, F. W. (Portrait)	306
Kohler, G. A. E. (Portrait)	306

## L

Laconia Car Company, The*	110
Laconia Standard Truck*	675
La Crosse & Onalaska Street R'y*	717-718
Lancaster, O., Electric Road	436
Lancaster Railway Construction Co.	565
Last Glimpse of the World's Fair*	395
Launches at Pueblo, Electric	425
Launches for Pleasure Resorts, Elect'c*	388
Lawrence, Charles K., in Prison	713
Lawrence Conduit, The*	282
Lawrence, Kan., Incline Railway*	156-157
Lawrence Track Brake, The*	241

## LAW, STREET RAILWAY:

Abutting Property Owner may Cut Wires	359-340
Abutting Property Owners, Consent of	723
Abutting Property Owners, Rights of	159
Agreement Contrary to Public Policy	723
Assignment of Contract Rights	360
Boarding Front Platform	754
Boy Boarding Car	754
Boy Riding on Front Platform at Invitation of Motorman	498
Bridge is Continuation of Street	93
Bridge, Track on	93
Care of Motorman	414; 723
Care Required of Driver	754
Car Running Backward on Incline	160
Charter, Construction of	413-414
Chartered Rights and Burdens Continue after Consolidation	359
Child, Care Required to Prevent Injury to	159

## LAW, STREET RAILWAY:—Continued.

Child, Injury to	20-21; 159; 224-225; 360
Child Running in Front of Car	224-225
Collision with Buggy	224
Collision with Vehicle	225-226
Collision with Wagon Crossing Track	92-93
Collision with Wagon on Track	160; 498
Consolidation of Street Railway Companies	359
Construction Company	360
Construction of Street Railroad	93
Coupon Tickets	21
Crossing, Passenger Injured at	20
Damage by Car Approaching from Rear	94
Damages for Cutting Trolley Wires	413
Defective Street	498
Ejection of Passenger	498
Electric Car	414
Elevated Railroad Pillar	723
Evidence of Policeman Arresting Driver Inadmissible	225
Expelling Passenger for Failure to Comply with Rules	359
Expiration of Charter	21
Expulsion of Passenger from Car	93-94
Expulsion Wrongful	754
Extension of Street Railway	413-414
Failure to Stop Car after Knowledge of Danger	225-226
Fellow-Passenger, Injury Inflicted by	722
Frightened Team	225-226
Frightening Horse	414
Gates on Platforms	498
Grading Streets	723
Guard Wires	497
Horse, Frightening	414
Horse Going on Track	754-755
Inexperience of Person Killed	498
Injury by Iron Falling from Trolley Pole	498
Injury to Horse	225
Injury to Person Crossing Street	722
Injury to Person in Street	160; 722
Injury to Person on Step of Street Car	723
Injury to Section Man	755
Injury to Team	160
Injury Willful	754
Limitation of Time for Construction	93
Making Street Dangerous	160
Medical Aid	92
Motive Power	359-340
Negligence Contributory	20; 224-225; 360-361; 414
Negligence in Running Cars	224
Negligence of A Co-employee	415
Negligence of Company	160
Negligence of Car Company, Presumption of	498
Negligence of Car Driver in Frightening Team	360-361
Negligence of Driver	92; 160; 224-225
Negligence of Driver, Employer, not Owner of Car, Liable for	224
Negligence of Driver of Team	225-226
Negligence of Motorman	160; 754-755
Negligence of Motorman and Conductor	20
Negligence of Pedestrian	722
Obstructing Cross Street	21
Obstruction in Street	360
Obstruction near Track	723
Occupancy of Street, What Constitutes	93

**LAW, STREET RAILWAY:—Continued.**

Ordinances, City..... 21  
 Ordinance, Invalid..... 21  
 Owner of Car not Liable for Injury  
 Caused by Negligence of Driver  
 Employed by Another Company.....224  
 Passenger, Injury to...160; 753 754 755  
 Passenger, Injury to, by Derailment  
 of Car..... 92  
 Passenger Jumping from Moving  
 Car.....722  
 Passengers, Injury by Electric Shock  
 .....497-498  
 Paving Streets.....723  
 Rails above Level of Street.....225  
 Reorganization of Street Railway  
 Company.....360  
 Rights of Street Railway in Street.....723  
 Signal Car to Stop, Duty to..... 754  
 Sleigh near Track.....754  
 Snow Piled beside Track.....160  
 Snow, Removing from Tracks.....160  
 Speed.....722  
 Speed, Excessive.....224; 225; 754-755  
 Speed, Reasonableness of City Or-  
 dinance Regulating..... 92  
 Sparks Falling from Elevated Rail-  
 road.....160  
 Statements of Driver Regarding  
 Accident.....225  
 Step, Riding on.....755  
 Street, Car Obstructing Cross..... 21  
 Street, Defective, City Liable for.....225  
 Street, Duty of Street Car Company  
 to Repair.....498  
 Street Railway Tracks.....159  
 Streets, Municipal Control of..... 21  
 Tender of Fare, Reasonable.....93 94  
 Tickets, Coupon..... 21  
 Track Running through Cut in  
 Street.....225  
 Trolley Wires.....359-340  
 Trolley Wires Crossing Railroad  
 Tracks.....413  
 Unguarded Excavation.....723  
 Using Track of Other Company.....360  
 Vehicle, Injury to..... 21  
 Vestibule Decision, Ohio.....270-271  
 Wagon beside Track.....723  
 Wagon on Car Track.....498  
 Wagon Turning out of Track..... 94  
 Leavenworth Electric Railway\*.....  
 .....477 478 479 480  
 Leffler Railway System, The\*.....161  
 Lehigh Valley Traction Company Buys  
 Allentown & Bethlehem Rapid Tran-  
 sit Company.....193  
 L'Electricista.....492  
 Lenox Avenue Conduit, New York\*.....787  
 Leschi Park, Seattle, Wash.\*.....9 10  
 License Fees, Chicago Companies.....710  
 License Tax on Cars\*..... 25  
 Licenses in New York, Street Car.....450  
 Lift Bridge at Halsted Street, Chi-  
 cago\*.....219-220  
 Lifting Car Bodies\*.....358  
 Lighting Smith Car\*..... 383  
 Lightning Arresters, A. J. Wurts on\*.....330  
 Lightning Arrester, The Doane\*.....220  
 Lightning Arrester, The W. & W..... 273  
 Lightning, The Deadly.....480  
 Light that Failed.....70; 476  
 Like Lots of Others (Verse).....342  
 Lincoln Park\*.....70 71  
 Lithia Springs Electric Railway.....128  
 Littell, H. M. (Portrait).....198  
 Little of Everything, A.....403

Little Rock, Cost Per Car Mile at... 144  
 Live Wire, Touched a... 757  
 Locomotive for New York Elevated,  
 New\*.....165  
 Locomotive, The Heilmann\*.....212-213  
 London Bus, Another\*.....282  
 London, The Beginning of Tramways  
 in.....137  
 London, Transportation in..... 16  
 Los Angeles Dogs Walk.....120  
 Lost was Found.....762  
 Lots of It Coming (Verse).....632  
 Louisville Truck, The\*..... 37  
 Lowry, R. J. (Portrait).....553  
 Lubricant, New.....797  
 Lundell Stationary Motors\*..... 63

**MAC**

McCormick Rail, The\*.....266  
 McKeesport & Wilmerding Railway\*  
 .....170 171 172  
 McLean, T. H. (Portrait).....532

**M**

Made the Fire Fly.....718  
 Madison, Wisconsin, Railway, Receiver  
 for the.....491  
 Madras Electric Railway Begun\*.....131-  
 .....132 133  
 Madras Tramways Started\*.....782-783  
 Magnetic Blow-outs, Value of\*.....760  
 Mail, Express and Freight Service on  
 Street Railroads.....626 627 628  
 Maine Street Railway Association.....67; 500  
 Maintenance of Rolling Stock, Part I, 87  
 to 89; Part II, 184-185; Part III,  
 .....227; Part IV, 290-291  
 Making the Stockholders Useful.....124  
 Malochee, H. J. (Portrait).....216  
 Mauley, James T. (Portrait).....150  
 Market Street Railway Company Buys  
 Metropolitan Railway, San Fran-  
 cisco.....528  
 Marseilles Electric Railway\*.....22-23  
 Massachusetts Street Railway Associa-  
 tion.....89; 396  
 Mather Electric Company.....144  
 Mather Generators, The\*.....514  
 Mayo's Automatic Trolley Cut-out\*..... 45  
 Meaker, Jr., John.....675  
 Meaker Registers for Chicago City Rail-  
 way.....167  
 Mean Advantage, A.....481  
 Means, N. A. (Portrait)..... 172  
 Mechanical Power Needed in Calcutta.....686  
 Medals for Inventors, Franklin Institute 16  
 Melbourne Mutual Benefit Association...143  
 Merry-go-round as an Attraction\*.....346  
 Metropolitan Electric Company\*.....735  
 Metropolitan Traction Company Prize... 25  
 Micanite for Commutators.....657  
 Michigan Overhead Material\*.....659  
 Michigan Street Railway Association  
 .....330; 619  
 Middletown & Goshen Railway.....344  
 Midwinter Fair Traffic.....108  
 Mileage at Augusta, Me..... 86  
 Miley-Lavelle.....684  
 Milwaukee Street Railway, Supply De-  
 partment\*.....26-27-28 29  
 Mims, Livingstone, Maj. (Portrait).....553  
 Minneapolis, Mammoth Snow Plow at\*  
 .....173 174  
 Missed a Car.....228  
 Monthly Report, Standard\*.....694 695 696 697  
 Montreal Park & Island Railway Opened 60  
 Montreal's Annual Statement.....716

Morse Company's Car, The C. D.\*.....255  
 Motor Equipments, Performance of  
 Modern.....145 146 147  
 Motor Inspection\*.....328  
 Motormen, An Aid in Educating\*.....262  
 Motormen, Rewards to..... 19  
 Motormen, Testing Eyesight of...327; 489  
 Motors, Device for Disconnecting\*.....784 785  
 Motors in Europe, Gas.....567 568  
 Motors in Germany, Gas.....343  
 Motors, Lundell Stationary\*..... 63  
 Motors on Railroads, The Present  
 Utility of\*.....308 309  
 Motor, The Card Street Railway\*.....366 367  
 Motor, The New Westinghouse\*.....307  
 Motor, The Steel\*.....515  
 Motors, The Walker Street Railway\*656 657  
 Motor, Westinghouse Spring Suspen-  
 sion\*.....759  
 Mt. Lowe Electric Railway\*.....268  
 Mousam River Railroad\*.....17 18  
 Moving Houses over Railway Tracks,  
 .....Part I, 13 14; Part II, 75 to 77  
 Mules Get Loose\*.....119  
 Mule Was Sick, The.....151  
 Mundes, Frederick (Portrait)..... 46  
 Municipal Oppression at Baltimore.... 90  
 Municipal Ordinance, A Void.....345  
 Municipal Purchase of English Tram-  
 ways.....239  
 Municipal Purchase of Tramways.....305  
 Murphy and Bruning Poles.....451  
 Murphy, W. F. (Portrait).....460  
 Mutual Aid Society of Chicago City Rail-  
 way.....760  
 Myers, George W. (Portrait).....748  
 National Electric Light Convention.....174  
 National Railway Company's Report... 91  
 National School of Electricity.....349  
 Nelson, Samuel L. (Portrait).....273  
 Nest Egg for Employes.....788  
 Nevius, Thomas.....484  
 New Excuse, The (Verse).....165  
 New Haven Register, The\*.....385; 579  
 New Orleans Electric Railways\*.....  
 .....198-199-200-201 202 203 204  
 New Orleans, Engineering Difficulties  
 in.....572  
 New Orleans Tower Wagon, The\*.....362  
 New Orleans Traction Company's Over-  
 head Construction.....637-638 639  
 New Publications, 64; 192; 256; 322; 385;  
 .....393; 516; 519; 662; 810  
 Newsboy Nuisance in New York City...344  
 Newsboys, New York.....290  
 Newsboys on Street Cars.....766  
 News from the Cities, 49 to 54; 113 to 118;  
 177 to 181; 193 to 248; 310 to 314;  
 371 to 376; 437 to 442; 501 to 505;  
 .....789-796  
 New York, Cable Extensions in\*.....429  
 New York Street Railway Association...619  
 New York Votes for Rapid Transit.....740  
 Nickels in Their Ears.....788  
 No Flies on Him.....344 345  
 North Chicago Street Railroad, Changes  
 at Limits.....499  
 North Chicago Street Railroad Traffic  
 Decoration Day.....362  
 North Shore Electric Lease.....612  
 Northwestern Electrical Association... 54  
 Northwestern Electrical Association,  
 Meeting of.....433  
 Northwestern Elevated Railway\*.....693 303  
 Not Always So.....258  
 Nourse, H. O. (Portrait)..... 738

Novel Advertisement of the San Francisco *Examiner*\*.....223  
 Nut Lock General Electric\*.....210  
 Nuttall Trolley Harps and Wheels\*... 492

## O

Obstructing Street Railway Tracks in Ohio, Penalty for.....686  
 Obstruction of Tracks at Troy.....781  
 Ohio Brass Company of Mansfield, The\*.....107  
 Ohio State Tramway Association.....620  
 Oil Cup, The Crown Glass\* ..... 25  
 On Account of Politeness.....630  
 One of Many.....291  
 One on the Conductor.....500  
 One Thing Needful, The.....141  
 Operating Expenses, A Query as to.....778  
 Operating Expenses in England and America.....407  
 Operating Expense of the Intramural Electric Elevated Railway\*368-369-370  
 Operating Expenses of the Portsmouth, O., Street Railroad\*.....690 691  
 Ottawa, Canada, Street Railway Progress.....412  
 Overcrowding Cars\*.....780  
 Overhead Construction.....275 276  
 Overhead Construction of the New Orleans Traction Company\*637-638-639  
 Overhead Material, The Michigan\*.....659  
 Overhead Railway, Performance of the Liverpool\*.....292  
 Overhead Special Work, Anderson\*....658

## P

Paid His Turkey's Fare.....757  
 Pain, H. (Portrait).....701  
 Parade, Street Railway Electric, at Houston, Tex\*.....46  
 Paragon Insulating Company.....797  
 Paris Underground Railroad\*.....305  
 Parmelee, H. S. (Portrait).....799  
 Partridge Carbon Company.....418  
 Passes\*.....629-630  
 Pass System\*.....693 694  
 Patent Office Gossip\*.....55; 126  
 Patents, Street Railway, 56; 111; 193; 250; 378; 444; 506; 578  
 Patent Void, A Cable Road.....213  
 Pavement, at Munich, New.....141  
 Pavement, Tipping of Wooden Block...484  
 Pavement to T Rail, Springfield\*.....337  
 Paving at Louisville, Ky., Brick\*.....357  
 Paving Blocks, Hay.....347  
 Paving, Brick.....335-336  
 Paving, Brick, Granite and Cedar\*....764  
 Paving, Osage Orange Fillers for\*....210  
 Paving to T Rail, Asphalt\*.....228  
 Paving to T Rail at Peoria\*.....419  
 Paving to T Rail, Brick\*.....32  
 Paving to T Rail, Steam Road\*.....165  
 Payne, Henry C. (Portrait).....532  
 Payne, J. Carroll (Portrait).....553  
 Peckham's Automatic Life and Wheel Guard\*.....433  
 Penalty for Obstructing Street Railway Tracks in Ohio.....686  
 Pennsylvania Street Railway Association.....500; 519  
 Pennsylvania Traction Company.....157  
 Peoria, Central Railway Fire.....495  
 Peoria, Standpipe Accident at.....302  
 Perrine, Louis (Portrait).....532  
 Personal, 59; 72; 188; 206; 322; 329; 396; 463; 521; 676; 734-735

Personal Examination of Injuries in Damage Suits.....153-154  
 Personal Injury Suit.....356-357  
 Personal Injury Accidents and the Management of Employees.....774 775 776  
 Peterson Conduit, The\*.....185  
 Petroleum Brick Fuel.....289  
 Pfingst Fender, A Feat of the\*.....124 125  
 Pfingst, Louis (Portrait).....125  
 Philadelphia Electrical Equipment Company.....768  
 Phillips, E. F. (Portrait).....563  
 Phillips, Samuel L. (Portrait).....523  
 Pickens, S. V. (Portrait).....397  
 Pictorial Events of the Month\*.....43; 128; 204; 380-381; 807  
 Pitt Folding Gate\*.....107 108  
 Pittsburg, Fire in Car Barn.....760  
 Pittsburg Traction Co.'s Annual Report 80  
 Placing of Car Trucks for Rounding Curves\*.....30 31  
 Plan, Fifty Thousand Dollars for a... 25  
 Pleasure Resorts and Created Travel, Part II, 9 to 11; Part III, 70-71; Part IV, 168 169; Part V, 208-209  
 Pleasure Resort of the Binghamton, N. Y., Railroad Company\*469-470 471  
 Plots against Indianapolis Street R'y... 47  
 Plowing in Cities\*.....761  
 Pneumatic Conduit Rail'd, An Ancient 355  
 Pneumatic Quick Break Switch\*.....143  
 Poles, Center, on Residence Streets\*766 767  
 Poles from South Carolina\*.....460 461  
 Poles, Murphy & Bruning.....451  
 Pooler, F. (Portrait).....717  
 Portland, Ore., Three-wire System at\* .207  
 Portsmouth, O., Street Railroad. Operating Expenses of\*.....690 691  
 Postage Stamp Tickets.....19  
 Potential, Heavy Drop of.....211  
 Power, Artesian Well, South Dakota\*...4 5  
 Power at Little Rock, Cheap.....119  
 Power by Damming North Channel\*...338  
 Power House, Cincinnati, Newport & Covington Railway\*.....331-332-333  
 Power House Construction and Insurance Rates.....149-150  
 Power House, In the.....525 to 528; 611-612; 680 to 682; 798 to 802  
 Power House of Lafayette Street Railway\*.....276 277  
 Power Houses of the West Chicago Street Railroad Company, The New\*.....285 286 287 288-289  
 Power House, Wheeling Railway Company\*.....350  
 Power in Europe, Distribution of Electric.....295  
 Power Selling and Underwriters' Rules.....104-106  
 Power Station, New Orleans & Carrollton Railroad\*.....34  
 Power Stations, Autograph Recorder for\*.....352 353  
 Pratt, George E. (Portrait).....111 112  
 Preece on American Electric Railways...144  
 Prizes, \$250 in.....319  
 Prizes, Chicago General Street Railway 507  
 Prizes, Oakland's.....83  
 Processions, Blocking Cars with.....416  
 Prout, A. W. (Portrait).....302  
 Pull Over, Double\*.....735

## Q

Question of Etiquette, A.....100  
 Quincy, Spontaneous Combustion at...333

## R

Rack Rail for Mountain Roads\*.....713  
 Rack Railway, Japanese\*.....770  
 Rack Road up the Wengern Alp\*.....148  
 Rail Cleaner, A German\*.....569  
 Rail for Mountain Roads, Rack\*.....713  
 Rail Joints, Hoffman Casting Process\*.....682; 749 750 751 752  
 Rail Joint, The Truss\*.....291  
 Rails of the Chicago City Railway, The New Standard\*.....566 567  
 Rails, Some West End\*.....74  
 Rails, Steel.....31  
 Rail, The McCormick\*.....266  
 Rail, Toledo, O., Endorses T.....689  
 Railway, Aerial\*.....96  
 Railway Equipment Company, Chicago, Assigns.....64 124  
 Railway Mail Service, Part I, 398 to 401; Part II, 686 689  
 Railway on the Ice\*.....345  
 Ranken-Fritsch Corliss Engine at Cianta\*.....577 578  
 Rapid Transit Dream\*.....371  
 Rapid Transit in New York\*.....175 176  
 Rattle in Street Cars.....571  
 Rawhide Belting, Patent Grooved Sable\*.....442  
 Receipts of York Street Railway.....75  
 Recorder for Power Stations, Autograph\*.....352-353  
 Recording Voltmeter, Bristol\*.....37  
 Record of Cradock Rope.....370  
 Reed, W. Boardman (Portrait).....237  
 Refuse Burning in Power Plants\*.....242  
 Register, An Aluminum\*.....61  
 Register, New Haven Car.....385; 579  
 Register, The Ames\*.....112  
 Register, The Rose\*.....788  
 Request Articles.....706 to 707  
 Return Circuits.....216 217-218  
 Return, Notes on the Ground.....708  
 Revolving Track Broom, A\*.....490  
 Review of the Year with Our Advertisers.....803 804 805 806  
 Rewards to Conductors and Motormen. 19  
 Rheostat and Series-Parallel Control\*.....685-686  
 Rheumatism, Cures.....628  
 Rhoads, Hiram R. (Obituary and Portrait).....137  
 Richardson, William (Obituary and Portrait).....8  
 Richardson, William J. (Portrait).....532  
 Richardson, William, Reminiscences of. 33  
 Richardson, William, Will of.....120  
 Riding Gallery as a Resort Attraction\*..346  
 Road Building, Electricity in.....628  
 Robins Fender Test.....354  
 Robinson, J. C. (Portrait).....687  
 Robison's Rail Bond\*.....747  
 Rock Island Bridge, The Trolley on the\*.....238  
 Rogers, F. A. (Portrait).....662  
 Rope Driving.....32  
 Rope with a Record.....490  
 Rosenbaum, Albert S. (Obituary).....189  
 Rose Register, The\*.....788  
 Routed the Militia.....713

## S

Sacramento, Central Electric Railway...530  
 Safe Robberies, How Not to Prevent...785  
 Safety Clutch Brake, A\*.....120  
 St. Louis Electric Brake\*.....802  
 St. Louis, Fire at.....207

<p>St. Louis Passenger Traffic.....95 295 500  Sand Box, Eureka*.....810  Sand Box, Holbert*..... 32  Sand Box, The Common Sense*.....194  Sandwich Islands Electric Railway*.....701  Sardusky, Milan &amp; Norwalk Electric  Railway*.....299-300-301-302  Sargent, George Nicholas, Married.....402  Sargent Shoe, The.....361  Savannah, Ruins of Car House..... 69  Scale of Energy, A*..... 335  Sawtooth Brake Shoe, The*..... 85  Scott Spring Company, Charles.....718  Seattle City Railway Park*.....9-10  Seaton, W. L. (Portrait).....554  Seeing Power for Outdoor and Farming  Purposes*.....714 715  Separator, Test of Webster.....125  Sejes-Parallel and Rheostat Control*  .....685-686  Seven Stages of a Street Railway, The  (Verse).....142  Sevey Fare Box, The*..... 86  Shades and Holders, the Davis*.....192  Shaw, George B. (Obituary)..... 521  She Had Grown.....686  Shocks. Resuscitation after Electric.428-700  Short Circuit and Runaway Car, Wal-  tham, Mass.....764  Short Circuited Affection.....412  Siemens-Halske Factory at Chicago  Burns*.....464-465  Signal at Sioux City, Walker's Block*..700  Signal for Single Track Roads, A Block*.189  Signaling Device, Electric*.....287  Signaling Device for Street Cars, A  New*.....189  Signals at Buffalo, Block*.....166  Sign, An Illuminated Car*.....193; 761  Simonds Steam Wagon, The*.....402  Simpson, Harry C. (Portrait).....556  Sinclair, W. H. (Portrait).....103  Sioux City Engine &amp; Iron Works.....151  Sioux City's Consolidation..... 23  Skating Rink, Dubuque, Iowa.....777  Sleet Trolley*..... 73  Slocum, Gen. Henry W. (Obituary)....322  Small Street Railways, Construction and  Operation of.....683-684  Smith Car Lighting*.....383  Smith Trolley Hanger, The*.....119  Smith, Willard A., Testimonial to*....386  Smoking on Cars.....397  Sneddon, J. P. (Portrait).....578  Snow, Bucking*.....11-12-13  Snowden, Clifford L. (Portrait).....654  Snow Plow, An Ingenious*.....757-758  Snow Plow at Minneapolis, Mammoth*.  .....173-174  Snow Plow for Rough Streets*.....182-183  Snow Plow on the Mousam River Elec-  tric Locomotive*.....240  Solar Carbon and Metal Brush*.....337  Some Verse on the Boston Schemes  (Verse).....496  Soper, W. Y. (Portrait).....532  Sorrows of the Old Man, The.....362  South Dakota's Wonderful Power*....4-5  Spark Arresters Next.....277  Spear &amp; Smith Track Switch*.....223  Special Track Work at Rochester, Some  Fine*.....424  Special Work, Anderson Overhead*....658  Special Work at Milwaukee, Compli-  cated*.....616  Special Work, Queer*.....512</p>	<p>Special Work with T Rail at Paige Iron  Works*.....572  Speed, Economy of High.....550  Speed Indicator for Motorman.....147-148  Speed of Trolley Car.....699  Sperry Electric Brake in Chicago*..467 468  Sperry on the Electric Brake*..641 642 643  Spike, Bracey's Improved Railroad*...282  Spillman Trolley Ear, The*.....418  Spitter, The Street Car.....142  Spontaneous Combustion at Quincy*...333  Springfield, Improvements at.....759  Springfield, Pavement to T Rail at....337  Sprinkler, Jackson &amp; Sharp, New*....691  Sprinkling, Street Railway*.....480 481  Staffordshire (Eng.) Electric Tramway.490  Standard Railway Supply Company Ex-  tends Its Field.....451  Standard Switch Throw, The*.....108  Stanserhorn Railway*.....78-79  Starting System of Chicago City Rail-  way, The New Car*.....407  Steam and Electric Railways.....429-430  Steam Roads, What Street Railways  can Learn from*.....772-773  Steam Valve Hand Wheel, a Cool*....160  Steel Motor Company*.....515  Steel Rails.....31  Steel Trolley Poles, Drawn.....566  Stephenson, William J. (Obituary)....521  Stillman Track, The*.....280  Stilwell Railroad Jack, The*.....353  Stops, Far or Near.....777  Storage Batteries for Central Station  Work at Merrill, Wisconsin...527-528  Storage Batteries in Central Station  Railway Work in Switzerland*....436  Storage Battery Company Enjoined....156  Storage Battery, Performance of the  Globe.....320  Storage Battery, The Hess*.....14  Strand Detector, A*.....94  Stratton Separators for Philadelphia*..528  Street Car Curiosity, A New Orleans*.. 7  Street Car Reform (Verse).....119  Street Cars, Water Power for..... 34  Street Railroading in the Early Days..  .....482-483  Street Railway Law, 20-21, 92 to 94; 159-  160; 224 to 226; 359 to 361; 413-414;  497-498; 722-723; 728 to 733; 753 to 755  Street Railway Progress—1894....746 747  Strike at Long Island City.....227  Strikers Sentenced, Toledo.....306  Strike in the Family.....397  Struck by Lightning.....758  Subway Scheme, Boston's..... 42  Suit of Margaret Longfield.....119  Summer Cars, Early.....240 241  Sunday Cars.....571; 745  Sunday Service in Scotland.....166-167  Supply Department of Milwaukee  Street Railway*.....26-27-28-29  Superintendency, A Graphic Method of*  .....135 136  Suspended Railway, Knoxville's.....74-75  Sweet Limit Switch*.....490; 740  Switchback Railway at Decatur.....418  Switchboard, General Electric Gen-  erator*.....507  Switches, Heavy Current*.....620  Switch for Cars, Sweet Limit*.....740  Switch, Pneumatic Quick Break*....143  Switch, Terminal, on Chicago City Rail-  way*.....772 773  Switch, The Hill Automatic Rheostat*..433</p>	<p>Switch, The New W. S. Hill*.....334  Switch, The Sweet Limit*.....490  Switch Throw, The Standard*.....108  Switch, Spear &amp; Smith Track*.....223  Sydney, Australia, New Cable Line....762  Syracuse Consolidated Street Railway  Company, Failure of.....19</p> <p style="text-align: center;"><b>T</b></p> <p>Tale of a \$5 Gold Piece.....710  Tama &amp; Toledo Electric Railway*..643 644  Tangible Terror, A (Verse).....514  Tar as Fuel.....710  Taxation.....610; 645 646 647  Taxes in Providence..... 89  Tax on Cars*..... 25  Taylor Trucks, Principles of the*.....221  Taylor, W. V. M., M.D. (Portrait)....172  Technic Improved Rail Bond*.....571  Telephone Patent to Expire..... 47  Tension Way, A New Style of*.....226  Terre Haute Electric Railway, T Rail  Construction*.....587  Terre Haute, Lessons from*613 614 615-616  Texas Street Railway Association...19; 103  Thomas, E. (Portrait).....552  Thomas' Life Fender*.....295  Thought He Was a Dummy..... 558  Three of a Kind.....692  Three-wire Trolley System at Bangor,  Me*.....513  Three-wire Trolley System at Portland,  Ore*.....207  Ticket Counter, Wanted a.....416  Ticket Recorder*.....90  Tickets and Transfers at Melbourne... 7  Tickets, Postage Stamp.....10  Tickets, Some Foreign*.....304  Ticket, Transfer*.....337  Tie Plates and Tie Rods*..... 99  Tie Plates and Track Repairs.....293  Tie Rods and Tie Plates*..... 99  Ties, Sells Oak.....797  Tie, The Daniels Steel*.....568  Tine Card and Power Station.....419  Time Tables and Train Schedules, Part  I, 340-341; Part II, 494 to 496; Part  .....III, 633 to 635; Part IV, 705  Tindolph, Allen, Capt. (Obituary).... 492  Tindolph, E. F. (Portrait).....101  Toledo Consolidated Street Railway  Election.....257  Toledo's Tracks..... 83  Tool Car*..... 35  Toronto's Blue Law.....571  Tower and Tool Car*..... 35  Tower Bridge, London*.....452  Tower Wagon, Davis*..... 43  Tower Wagon, The Breed*.....188  Tower Wagon, The Hartman*.....227  Tower Wagon, The New Orleans*....362  Track Brush Holder, Adjustable*....727  Track, Location of Car.....262  Track, The Stillman*.....280  Track Welding at St. Louis*263 264-265-266  Trainload of Cable Cars*..... 44  Trains for Interurban Service*267 268 269  Tramway, a Name Wanted..... 6  Tramways Institute of Great Britain,  Meeting.....484  Tramways in the United Kingdom.411 412  Tramway Traction Methods Compared  .....421 422 423  Transfer, Milwaukee's New*.....416  Transfer on Street Railways.....670 671  Transfer on the Chicago City Railway* 470</p>
---	---	---

Transfers, West End Street Railway, Boston.....378  
 Transfer Ticket\*.....337  
 Transfer, Toledo's\*.....423  
 Transportation by Wind Power\*.....214  
 Transmission, Long Distance, at Genoa \* .....138-139-140-141  
 Transmission of Power by Rope.....32  
 Transmission of Steam, Long Distance.....160  
 Transportation in London .....16  
 Tranter Fender, The\*.....273  
 Trawick, S. W. (Portrait).....554  
 T Rail, Asphalt Paving to\*.....228  
 T Rail in Paved Streets.....601 602 603  
 T Rails in San Antonio.....137  
 T Rails Prevent Accidents .....759  
 T Rail in San Francisco\* .....144  
 T Rail, Seven-inch Shanghai\* .....768  
 T Rails for Street Railway Use\*.....38-39-40  
 T Rail, Toledo, O., Endorses .....689  
 T Rail Track Construction of the Terre Haute Electric Railway\*.....587-588 589 590-591  
 Trolley Base, The Chicago\*.....125  
 Trolley Base, The Gaynor\*.....164  
 Trolley Car Man, The (Verse) .....561  
 Trolley Clamp, Hercules\*.....320  
 Trolley Cut-out, Mayo's Automatic\*.....45  
 Trolley Ear, The Spillman\*.....418  
 Trolley Fork, The Kuapp Swivel\*.....45  
 Trolley Hanger, The Smith\*.....119  
 Trolley Hangers, The Western Electric\*576  
 Trolley Hanger, Walker\*.....691  
 Trolley Harps and Wheels, Nuttall\*.....492  
 Trolley Harp, The Hubley\*.....562  
 Trolley Head, The Bidwell\*.....108  
 Trolley Head, The Duncker\*.....96  
 Trolley Head, The Falk\*.....449  
 Trolley Head, Walker's New Design\*.....240  
 Trolley Party Fad in Philadelphia\*.....569  
 Trolley Poles, Drawn Steel.....566  
 Trolley Railways in England .....157  
 Trolley Sling, The Jewell\*.....658  
 Trolley System (Play).....779  
 Trolley, The Cornstalk Club Discusses The\*.....408 409 410 411  
 Trolley, The Haight & Clark Sleet\*.....73  
 Trolley, The Independent\*.....358  
 Trolley Wheels, Ice and Sleet Cutting\*.....579  
 Trout by Trolley.....282  
 Troutman, H. E. (Portrait) .....511  
 Troy, Obstruction Nuisance Suppressed at.....781  
 Truck, Barney & Smith\*.....361  
 Truck, Fulton Imperial\*.....60  
 Truck, Graham's\*.....61  
 Trucks and Curves\*.....30-31  
 Trucks, Wright's New Method of Mounting Cars on Single\* .....425  
 Truck, The Empire State Radial\* .....565

Truck, The Hansell\*.....508  
 Truck, The Laconia Standard\*.....675  
 Truck, The Louisville\*.....37  
 True Stories Heard at Convention.....715 716  
 Truss Rail Joint, The\* .....291  
 Tunnel of West Chicago Street Railroad Company\* .....285-286-287 288 289  
 Two Wise Men (Verse) .....382

**U**

Underground Feeders.....295  
 Underground Railroad, The Paris\*.....305  
 Underwriters' Rules, Power Selling and .....104-106  
 Universal Brace Bar Handle\*.....707  
 Unreliability of Daily Press.....215 351  
 Urbana & Champaign Electric Railway Company's Pleasure Resort\*.....353  
 Utica Belt Line Reorganizes .....512

**V**

Vail, J. H., on Rail Bonding.....213  
 Valier, P. (Portrait) .....717  
 Van Dorn Automatic Draw Bar\* .....676  
 Vehicles Following Street Cars.....94  
 Vestibule Decision, Ohio .....270 271 272  
 Vestibule Law Valid, Minnesota\*.....415  
 Vestibules at Du Bois, Pa.\*.....44  
 Vicksburg, Miss., Street Railway Case.....567  
 Vincennes Citizens' Electric Street Railway\* .....101-102  
 Vining, E. P. ....762  
 Voltage, its Relation to Speed and Time Table .....281  
 Voltmeter, Bristol Recording\* .....37

**W**

Wages in Boston.....77  
 Wages in Ohio and Missouri.....97 98 99  
 Wages of Conductors and Drivers in Europe .....727  
 Wagon, The Simonds Steam\* .....402  
 Wain, W. J. Carruthers (Portrait) .....484  
 Walker Generators, The Large\* .....473  
 Walker, John, Comes to Chicago.....209  
 Walker Manufacturing Company, Electrical Machinery of\*.....249 250  
 Walker Manufacturing Company, The, 40 Walker's Block Signal at Sioux City\* .....700  
 Walker's New Design Trolley Head\*.....240  
 Walker Street Railway Motors, The\*656-657  
 Walker Trolley Hanger\* .....691  
 Walls, Waterproof Coat for .....344  
 Waltham, Mass., Short Circuit and Run-away Car.....764  
 Walton's Link Belting\*.....85  
 Wants Golden Chariots .....708  
 Ward Electric Bus in London, The\*.....210  
 Watermelon Festival in Alabama\*.....523  
 Water Pipes, Electrolysis of, at Milwaukee\* .....16

Water Power for Street Cars.....34  
 Watt Hours per Car Mile.....499  
 Waukesha Road Seems Assured.....654  
 Weather and Open or Closed Cars.....327  
 Webster Separator, Test of .....125  
 Weeds, Killing by Electricity .....698  
 Weir Frog Company, The.....44  
 Welding at St. Louis, Electric Track\*, .....263 264-265-266  
 Welding Continuous Rails .....174; 749 750  
 .....751-752  
 Wells & French Company to Build Street Cars\* .....654 655  
 Wessels, E. J. (Portrait).....597  
 West Chester Side-tracked.....555  
 West Chicago Street Railroad Company Tunnel and Power Houses\*.....285 286 287-288-289  
 Western Electric Company in the Railway Field\*.....520  
 Western Electric Trolley Hangers\*.....576  
 Western Engineers' Excursion.....756  
 Westinghouse Controller\*.....307 308  
 Westinghouse Motor, Spring Suspension\*.....759  
 Westinghouse Motor, The New\*.....307  
 Wharton's Wooden Faced Brake Shoe\*.....347  
 What Fools These Mortals Be .....240  
 Wheel, A New Car\*.....660  
 Wheel, A Novel.....279  
 Wheeler, George K. (Portrait).....342  
 Wheeling Railway Company\*.....349 350  
 Where Circulars Go.....351  
 White-Crosby Company, The.....229  
 White-Crosby's Prize.....465  
 Whitney Car Wheel, The New\*.....660  
 Who Paid the Fare.....705  
 Widener, Peter A. B.....707  
 Willcox, Stephen (Obituary and Portrait).....62  
 Willard, B. (Portrait).....204; 637  
 Wind as Railway Motive Power\*.....214  
 Winters Car Brake, The\*.....341  
 Wires, Must Bury the.....295  
 Woman's Latest Victory\*.....316  
 Woodruff, Ernest (Portrait) .....551  
 Wood, Thomas (Portrait).....302  
 Woodworth, Chauncey C. (Portrait) .....483  
 Worthy, John (Obituary).....745  
 Wreck Wagons\*.....393 394  
 Wrench, A Home Made Pipe\*.....303  
 Wright's New Method of Mounting Cars on Single Trucks\*.....425  
 Wyandotte & Detroit River Railway, Test of.....417  
 Wyman, C. Densmore (Portrait) .....176

**Y**

Young, C. P. (Portrait) .....758  
 Yuille, George A. (Portrait).....119





WINDSOR & KENFIELD,  
 PUBLISHERS AND PROPRIETORS,  
 269 DEARBORN ST., - - - CHICAGO.  
 Published on the 15th of each month.

SUBSCRIPTION, - - - TWO DOLLARS.  
 FOREIGN SUBSCRIPTION, - - - 20 SHILLINGS.

Address all Communications and Remittances to THE STREET RAILWAY REVIEW,  
 269 Dearborn Street, Chicago.

H. H. WINDSOR, Editor. F. S. KENFIELD, Business Manager.

**CORRESPONDENCE.**

We cordially invite correspondence on all subjects of interest to those engaged in any branch of Street Railway work, and will gratefully appreciate any marked copies of papers or news items our street railway friends may send us, pertaining either to companies or officers. Address:

THE STREET RAILWAY REVIEW,  
 269 Dearborn Street, Chicago

Eastern Office, Room 14, No. 126 Liberty Street, New York.

This paper member Chicago Publishers' Association.

Entered at the Post Office at Chicago as Second Class Matter.

VOL. 4. JANUARY 15, 1894. NO. 1

Moving houses across and along railway tracks was quite bad enough under horse car practice, but where trolley wires must be cut is a positive nuisance. The general opinion is for securing municipal legislation which shall furnish suitable protection.

A LARGE field, as yet untouched, is the construction of electric lines for handling freight cars from the main line of steam roads, a few miles, to inland towns. Where water power is available the problem becomes one of easy solution. Such a line has been in very successful operation for some months past, in Maine, and in addition to the heavy work named does a good passenger and express business.

THE question as to the specific difference between a surface and elevated railroad, received a precedent in Pennsylvania in the recent decision of the case of the City of Philadelphia against the Northeastern elevated railroad, whose charter announced it as "a street passenger railway." The court held that whether built and operated on the surface of the street, or on pillars or posts at some distance above the street, it was the same in either case, "a street passenger railway."

A POSSIBLE use for the several hundred old and very small horse cars, now in disuse throughout the country, may be suggested by the tower and tool car described

this month. Some of the cars named are even unfit for joining with another similar car and being converted into twenty foot bodies, but may at trifling expense and with the ordinary help available on every road, be converted into portable machine shops for overhead repairs, and still do good service for the new power and the new age which have displaced them.

"THESE channels of internal communication will be multiplied, till all the broad avenues of the city are occupied by them," says Bellew's Pictorial magazine, in 1855, as quoted elsewhere in this number. "We have no doubt," continues the writer, "that within a few years many of our suburban villages, which are now served with omnibuses, will be connected with the city by horse railroads." How fully the prediction has been realized is evident from a glance at our monthly directory of American street railways.

ONE of the most needed city ordinances, and not in Chicago alone by any means, and a measure which has long and earnestly been advocated by this magazine, has now become an operative municipal law. It is none other than making it an offense for children of either sex under eighteen years of age, to "hitch on" moving street cars. It might occasion a smile with some who read this but who have never visited certain districts of this city where girls from six to fifteen years of age vie with the boys as to who can cause the conductor the most trouble. The first enforcement of the law resulted in a large catch, which was treated to one night in the lockup and a dollar fine, per head, next day. What has been an unmitigated nuisance, for years past, now promises to be wholly remedied. It is a law which should exist in every city. We print the text of the ordinance elsewhere.

IN the Ohio legislature a bill has been introduced making it obligatory upon all municipalities in the state to grant street railway, gas, and similar franchises, only to the highest competitive bidder. This opens a fine field for the sand-bagger, and will certainly delay, if not entirely prevent, the building of lines which would otherwise be constructed. The residents of any community have only to gain by increased transportation facilities of any kind, and instead of adding to the already heavy burdens of these enterprises it would be much the wiser to raise a bonus and give the new road a lift. It is impossible to construct a new line without advancing the value of property, and the city and state receives an increased revenue from this increased valuation, which should be considered as ample discharge of whatever obligation pessemistic legislators may suppose to exist.

THE REVIEW makes its annual bow, and admits that with this number it is three year's old, and "goin' on four" now. We refrain from calling special attention to the fact that the past year has been a peculiarly hard one on publishers, and that the favorite trade journals in all lines of business have lost a large amount of patron-

age—some as much as one-half. It is, therefore, with modest pride that we are able to announce that the REVIEW shows a handsome increase in the year's business of 1893. No economy has been practiced, or the question of cost once allowed to enter into the consideration of what was deemed desirable or necessary for our reading columns. This current issue is simply a fair sample of what our readers have had each month, and were it not against our established policy we should like to print every one of the many hundred letters of appreciation and encouragement our readers have so generously and kindly sent us. We prize them highly, and find in them our best endeavor for improvement. This reminds us, the REVIEW this year will,—well, just watch, kind reader, and you will see.

REPORTS from our correspondents in various parts of the country while somewhat guarded are, in the main, surprisingly hopeful, and denote a decided improvement in railway work as near at hand. Roads have wholly exhausted their stock of repair parts and are forced to become considerable buyers in these lines, and for immediate consumption. Other roads which are only operating one-third or one-quarter their usual equipment, are in many cases, stripping the idle cars to repair those running, and as soon as spring opens, with necessarily increased riding, there will be a sudden and extended demand. As to new lines, there is much to encourage; with the banks full of idle money, both East and West, there will be no great difficulty in securing proper aid for strictly legitimate enterprises, which will take advantage of the lowest prices in materials and labor in years, to build. Many lines will surely be built this summer, and employment for the working classes is bound to increase as spring advances. This will be speedily felt by roads which are not now earning more than expenses. Taken altogether, we consider the outlook and conditions as showing a decided improvement, and that the worst is over.

WITH the fading light of the dying year went out the life of one, who unlike it, possessed his strength of mind and body to the very last. No name was more familiar or words of counsel better known in the street railway fraternity, than those of William Richardson. To a commanding voice and figure he added the ripe experiences of his three score years and ten, and guided both by a thoroughly well-balanced mind. Nor was he devoid of humor, and the record of conventions for the last ten years reveal a ready repartee which was shot as an arrow from the bow: yet he always maintained that quiet dignity and self-possession which marks the true gentleman. Doubtless no one was better known than he, both in the city of his home, and the councils of the American Street Railway Association, and the news of his demise is received with sadness and surprise. There is feeling of pain that one who was just about to retire and enter upon the enjoyment of accumulations and honors, the fruit of a life of intense activity, should not have been spared the fulfillment of that desire, yet those who knew him best realize

that to one of his temperament and ability, a life of idleness would have been impossible. He died with the harness still on, in the strength of accomplished successes, and the beauty and respect of a life well lived.

WE publish this month a description of one of the most novel and interesting features of electrical power supply it has been our privilege to lay before our readers. Books by the score have been written on the utilization of the power of falling water, but it has remained for the enterprising people of South Dakota to throttle the force of the wonderful artesian wells, which, like magic, have responded with veritable geysers, where man explored the secrets of old Earth with his diamond drill. Laying aside the multitude of interesting questions as to the source of this supply, we accept its existence, and look forward with confident expectation to a remarkable utilization of this power in the production of electricity. The roar and beauty of Niagara are wanting; only a few feet of steel pipe protruding from the ground; only an unpretentious water-wheel and a sparkling little river running away on its beneficent errand of irrigation. But it is the same effective power, and progressive minds have already consummated plans which will ere long furnish transportation between the young towns and villages which are rapidly becoming cities, and electricity will be the medium of the power; and old Nature will give of her secrets and her strength to generate this electricity. We dare suggest this approaches very near to something new under the sun.

WHEN the Metropolitan Traction Company, of New York City, shall have completed the construction of the additional cable lines for which it now has franchises, it will have reached the limit within which cable construction is practical. The cable is undoubtedly the more economical system where a large volume of business must be handled and the route is reasonably straight. To complete the necessities of rapid surface transportation in that city requires a system which shall follow the beaten paths of travel established by the public, and which involves a winding route, much of which covers streets where travel is light as compared to such great arteries as Broadway. On these lines the company properly desires to operate the trolley system. The conduit system of electric traction has never been successfully operated in this country, nor have storage batteries as yet fully demonstrated their claims, although some advance seems to have been made in this direction during the past six months. The trolley, therefore, presents the only relief at present. If there is any better system the Metropolitan wants to know it, and to bring the question to a positive issue, have offered to pay \$50,000 for any plan which shall be presented before March 1, of this year, and have named the State Board of Railroad Commissioners as the judges. The prize is a large one, and if any method superior to the trolley exists, now is the time to substantiate its claims. If none can claim the reward the public in all fairness is bound to accept the verdict.

THE scheme, for it is nothing more, of one J. E. Dunn, to secure a Congressional bill establishing a District commissioner, and himself as that functionary, with the privilege of assessing every grip and motorman five dollars for an examination as to fitness, is an outrage and an absurdity. Dunn tries to draw a precedent from steamboat engineers, who are very properly under government surveillance. Of course the condition of a vessel with a boiler in momentary danger of explosion and miles from any place where experienced men know anything about such matters, is not a circumstance to the awful peril of a car load of street car passengers at the moment when a brake shoe becomes cracked or the fare register fails to work, and the company's shops and barns mayhap as many as two blocks from the scene of mechanical carnage. But if the examination of street railway men has any merit, let the good work be extended to include drivers of merchants' delivery wagons, and the festive milkman, and the lackey who drives the senatorial coach, and the omnibus man; all of whom are far more dangerous to humanity than the car driver who can't drive outside of his established line of rails to save his life. Then there is the man with a wheelbarrow, who, under many circumstances, can be a really dangerous person; and the push cart, which is not entirely devoid of peril, and by no means that least menace to society—the hand organ. Car drivers also should qualify on a West Point final examination, and possess none but sound teeth; have the necessary height and weight, and be able to lead the german. In the mind of the schemer all this should be Dunn.

CHICAGO ALLEY L ELECTION.

The election of three directors for the Chicago & South Side Rapid Transit Company was the occasion of some excitement, January 4, owing to the dissatisfaction of a minority of the stockholders with the present management. The directors chosen were C. T. Gray, E. L. Lobdell and J. Hinkley. Mr. Lobdell represents the minority. The following table shows some interesting facts in regard to the performance of the road in 1893.

MONTH.	No. of Passengers carried	Earnings.	Expenses.	Percentage of expenses to earnings.	Average cost per passenger.
January.....	1,051,139	\$ 52,556	\$49,705	94.5	.0473
February.....	1,056,444	52,822	48,810	92.5	.0462
March.....	1,274,318	63,716	53,969	85.0	.0424
April.....	1,550,994	78,049	53,393	68.5	.0349
May.....	3,304,485	165,224	90,814	54.8	.0274
June.....	3,474,665	171,733	84,964	48.8	.0242
July.....	3,042,612	152,130	77,524	50.9	.0255
August.....	3,241,958	162,097	67,327	41.6	.0208
September.....	3,931,859	196,592	82,004	41.7	.0209
October.....	5,376,220	268,811	93,961	35.0	.0175
November.....	1,457,675	72,883	56,509	77.6	.0388
December.....	1,283,378	64,168	57,647	89.9	.0443

The December daily average of passengers carried is 41,399; total for year, 30,045,747.

DAY OF JUDGMENT.

For the Small Boys who Hitch on Chicago Street Cars.

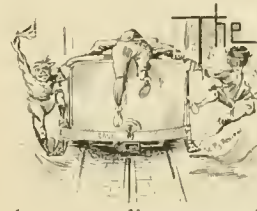

CITY COUNCIL of Chicago, on December 4 last, legalized one of the most needed and sensible acts of city legislation which has been accomplished here in a long time. It was none other

than an ordinance against hitching on street cars, and the text in full is as follows:

Be it ordained by the City Council of the City of Chicago:

SECTION 1. No minor under the age of eighteen years shall climb, jump upon, or cling to, or in any way attach himself or herself to any horse, cable, electric or other street car of any kind while the same is in motion.

SEC. 2. Any person who shall violate the provisions of Section one of this ordinance shall, upon conviction, be fined not exceeding the sum of ten dollars.

SEC. 3. This ordinance shall take effect and be in force from and after its passage and due publication.

Owing to the distractions of a municipal election the ordinance attracted little attention, and its sudden execution on January 1 came like a cyclone to the cyclonic small boy, who in large numbers celebrated the new year by disporting himself in his accustomed pastime. But a big cop was abroad in the land, and speedily deported enough young trespassers to fill a cage at the Harrison street station. They were kept all night in a cell, and next morning fined one dollar and costs, and went out into the new year with a desperate desire to let cable cars alone and to do missionary work among "de kids" who are still addicted to "hitching on."

It is a reform measure of more than passing importance and one which the REVIEW has advocated from the date of its very first issue. The success of the measure here should encourage managers in other cities to secure similar protection, which is at once a like protection to companies, the public, the parents of the offenders, and the children themselves. The damage claims from this source in a single month, on some roads, would well pay the trouble of securing the ordinance, against which not one good argument can be raised.

AN electric railway, now abandoned, running between Whitinsville, R. I., and Whittin Station, is now operated as a freight route by the Whittin machine shops. The passenger traffic did not warrant the continuance of the electric power.

It is suggested by several eastern newspapers, mainly of Boston, that street refuse and garbage wagons be dispensed with, and that the trolley garbage car be utilized. Then, too, the electric sprinkler could follow in the rear, and behind it could run the sweeper.

A READING, PA. genius suggests that in view of the alarming frequency of electric train robbers' hold-ups in various parts of the country, an electric exterminator be arranged so that the trolley circuit may also act as a protector for the passengers who carry valuables.

## SOUTH DAKOTA'S WONDERFUL POWER.

An Unique Opportunity for Electrical Development—Entirely Novel Source of Power—New Problems for the Electrical Engineer.

The idea of developing any considerable amount of power from artesian wells was heartily laughed at when first proposed, and it is very probable that a considerable number of those who read this article will scout the idea, as of exceedingly questionable feasibility. Nevertheless, work has been quietly going on in South Dakota for the past year, which proves that the artesian wells of the James River valley are as valuable and reliable a kind of water power as could be wished, and from all indications will continue to be so for years to come. Already a number of electric light and flour mill plants have been installed, and are in daily operation. These will be mentioned in detail later on.

The artesian well district of South Dakota is located in the valley of the James river, covering a tract about 40 miles wide and 200 miles long. The James river is about half way between the Missouri and the eastern boundary of the state. The water bearing rock is found at from 900 to 1,000 feet from the surface. The first and most vital question that comes up is as to whether the supply is reliable, and can be depended on to continue with its present pressure, as more wells are sunk and a greater volume of water is drawn from the underground source.

There are good reasons for thinking that the supply is practically inexhaustible. These reasons are based both on the theories advanced by the United States government geologists and on observed facts in connection with the sinking of wells. The government theory is founded on the fact that the same stratum in which the water is found, outcrops in the beds of the Upper Missouri and

Yellowstone rivers, and at the base of the Rocky Mountains. The water, sinking in this porous stratum of rock, follows it for hundreds of miles, until tapped by the South Dakota wells. It has long been believed that there is more water in the Missouri River above the Great Falls than there is thirty miles below. For twenty-five or thirty miles below the Falls the river bed is com-

posed of the same sand formation in which the South Dakota wells get their water. If this theory is correct, as it probably is, the supply of water to these wells may be looked upon as inexhaustible—at least, as much so as the sources of our Rocky Mountain streams. Another fact that would point strongly to the truth of this theory is, that during the June rise in the

Upper Missouri River, the pressure in the wells rises. No diminution in pressure has been noticed in any of the wells in the district, except by clogging up with mud, due to improper piping. The city well at Redfield has been down seven years. Its pressure has been constant, although numerous other wells have since been sunk at no great distances from it. This well furnishes a direct pressure system of water works, supplying all the domestic needs of the city, and so great confidence is placed upon the pressure and supply that the fire department requires no fire engines. The closed pressure of this well is 177 pounds, and cost for maintenance is absolutely nothing.

About a mile and a half distant is another well, used for running an electric light plant and for irrigation. A description of this well will suffice to give a fair idea of all. It is 1,000 feet deep, and six inches in diameter from top to bottom. When closed, the pressure is 165 pounds. When allowed to flow freely through the 6-inch pipe, it yields 2,027 gallons per minute, and rises to a height of sixteen feet in the air. When the water is escaping through a 2-inch pipe the well pressure is 128 pounds, and with a 2¾-inch opening 95 pounds. From this it is estimated that with a 4-foot Pelton wheel, 80-horse-power would be developed with a 2-inch opening, and 100-horse-power with a 2¾-inch. With the plain undershot wheel at present in place, 50-horse-power is developed, and it is calculated that about 15 more is available with it. The flow is absolutely steady. This well cost about \$3,000.

At Chamberlain, a 150-barrel flour mill and light plant, formerly run by steam, is now using "well power." These two plants were started in September, 1893. At Huron a well is about to be sunk by the city, for electric lighting purposes. The first electric light plant in the state, run from a well, is at Mellette, a town of 400 inhabitants. It is safe to say that very few plants in the world are



HASSELL & MEYERS' WELL, REDFIELD. 6-INCH STREAM 16 FEET.

doing a paying business in so small a place. This plant is thriving, however, and has connected 10 4-ampere arcs and 150 16-candle-power incandescents. The well is only four and one-half inches in diameter from top to bottom, but it operates besides the electric light plant, a flour mill, which grinds 150 barrels of flour a day and 50 bushels of feed per hour. This work would require an engine of 40-horse-power. The well is 910 feet deep. Its pressure when closed is 178 pounds. The flow is 1,600 gallons per minute.

### A BRILLIANT FUTURE.

It does not require a vivid imagination to see the possibilities of the James River valley. Electric railways are already being considered, to connect farms and small villages with larger railroad towns. The most feasible of the plans proposed is to take land in tracts of about four sections, and sink two 8-inch wells at the middle of the tract, which would be divided into thirty-two farms of eighty acres. The water from both these wells would be used for power and afterwards for irrigation, which latter feature, by the way, is not the least important consideration in the development of artesian wells in this district. The power from one well would light and heat the hamlet of thirty-two families, and the other would run an electric railway connecting with the larger towns. This plan may, of course, have to be modified a little, and it may be found better to sink wells so as not to have too great a drain on the underground water reservoir at one point, as this would be liable to cause a considerable drop in pressure. The prospectus seems almost Utopian, but there are plenty of good practical reasons why it will probably be carried out. The only thing that could prevent the success of the scheme would be a failure of the water supply, and we have already shown that there is no reason to think the supply limited. As regards the economy of this power over steam there is no question.



Considering that the water is used for irrigation it is probably the cheapest power for use in small quantities in the world. The outlay for an 80-horse-power well is, as was seen, about \$3,000, the interest on which would be \$2.25 per horse-power per annum. This, with the interest and depreciation on the water-wheel is the only expense for primary motive power, aside from labor. A \$300 or \$400 building gives the wheel and dynamo a good shelter.

The repairs to water-wheel ought to be almost zero, and the skill of the men employed for attendance does not begin to be that required in a steam plant.

### NEW ENGINEERING PROBLEMS.

The tendency in electrical work in the past has been steadily toward an increase in the size of stations and a centralization of power. The water power of South Dakota requires progress in the opposite direction. The



HASSEL & MYERS WELL, REDFIELD. 2-INCH STREAM 150 FEET.

question of the future electrical engineer in South Dakota will be, "How can numerous small plants situated a distance apart be utilized to best advantage?" Especially does this question come up in connection with electric railway work. The use of the storage battery has been looked to by some in this connection as a means of best utilizing the power for railway work and as an adjunct to the generating stations it may prove useful. The cost of a trolley line on a country road is not very great and ought not to be prohibitive. It is very possible, however, that for such light work as would be required at present, the storage battery on the car would be the most economical solution of the question. At all events the development of South Dakota's unique power will be watched with interest by the country at large, and it is safe to say, be attended with profit both to electrical manufacturers and the farmers of that state.

The engravings of the well which now lights Redfield and which are here presented, are due to the kindness of R. B. Hassell, a well known lawyer of Redfield, who has a large interest in the plant, and who is an active worker in the development of the new power on the farm lands of his region.

The McKeesport & Wilmerding Electric Railway, down in Pennsylvania, has begun carrying Adams express. A passenger car was boarded up on the inside, a side door cut in, and there is your express car.

## FUNERAL CARS IN SAN FRANCISCO.

Beginning on September 17, 1893, the first electric funeral train in California, and one of the first in the United States, began regular service on the line of the San Francisco & San Mateo Electric Railway, which connects the Cypress Lawn Cemetery with the city. The distance is ten miles and the run is made in less than an hour. Switches are run into the grounds, giving every convenience for transferring.

The car, an engraving of which we are able to present, was built by J. Hammond & Son, of San Francisco, for the Cypress Lawn Cemetery Association. It is 31 feet long, divided into two sections. One part is for the

## WANTED: A NAME.

Sometimes, when the French, German, Spanish, and Italian tongues find difficulty in expressing a thought, idea or invention, the English is called upon, and the word transplanted bodily. Such has been the fate of tram, tramway, roast beef, and beef steak. The recent inauguration of an electric road at Lisbon, Portugal, has precipitated a discussion as to what it shall be called.

The "Gazeta dos Caminhos de Ferro," of that city, opened its columns, with a view to finding the best term to replace the English word "tramway," which is used in Portugal. The journal points out that the Spaniards, with their dislike of alien terms, turned "tramway" into "tran-

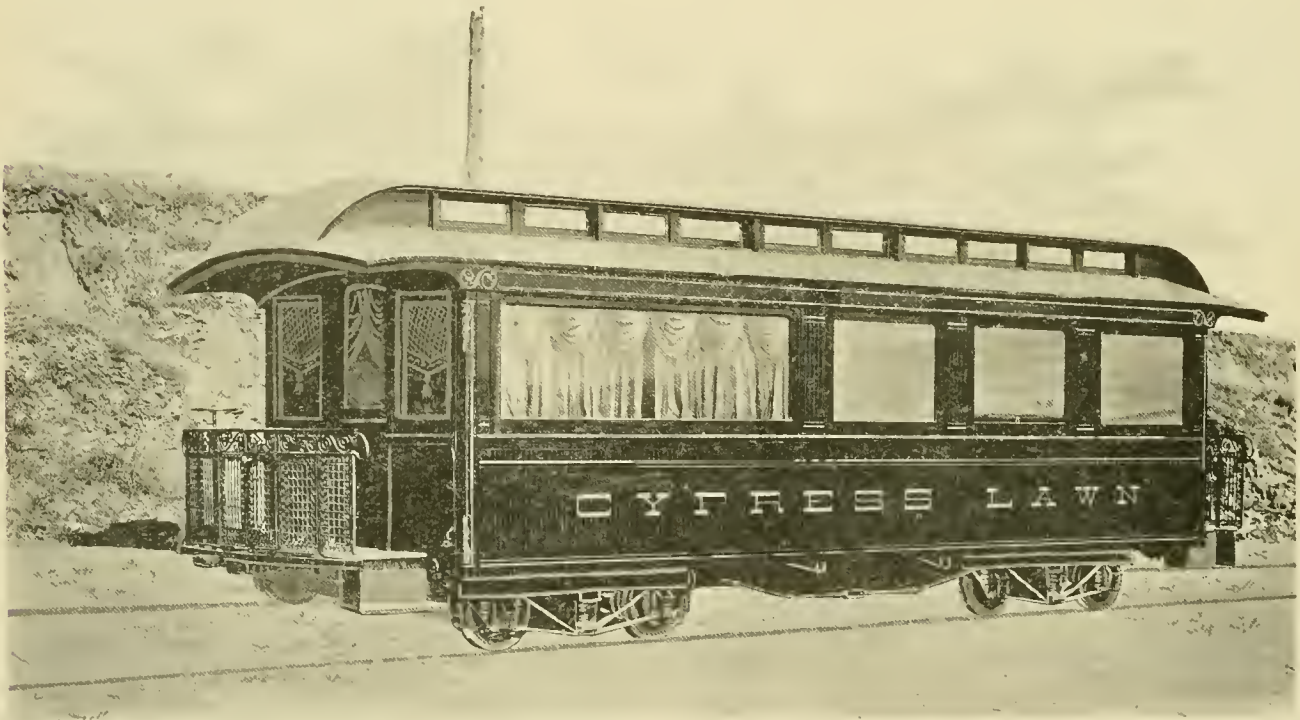

THE LARGEST STREET RAILWAY FUNERAL CAR IN THE WORLD.

remains and pall-bearers, while the other is occupied by the mourners. A track runs through the entire length of the car to the ends of the platform, so that the coffin can be loaded on from either end. The seats in the hearse section runs longitudinally on both sides and are of solid black walnut, in common with the rest of the inside finishing. The mourners' section has seats arranged as in palace steam cars, accommodating twenty-four people, and upholstered in dark olive plush. The exterior of the car is, of course, dark. A tariff of ten dollars is charged for the use of the car, and as many special cars for friends of the deceased as necessary may be chartered. Funeral processions may meet the train at any convenient place on the line and a hearse at the cemetery transfers to the vault or grave. The idea has been well received, and the convenience, economy and good taste of the service appeals to the wealthy as well as to the poorer classes. The car is run as a trailer.

via." The French use "tramway," but they satisfy their scruples by pronouncing it in their own peculiar way. The Germans say "strassenbahn," which is equivalent to the American "street-railway," but they also use "pferdebahn" (horse-road) and "tramway." Pending the decision of its readers, the Portuguese paper proposes "trem-via" or "carrovia." Probably the first word is as good as any that could be suggested.

NEW ZEALAND has a tramway called the Dunedin City & Suburban, which wants to apply electric traction, and a thorough investigation is in progress of the merits of this kind of traction.

THE new power house of the Neville Island & Corapolis Electric Railway, of Pittsburg, has been completed. It went into operation January 1, with eight cars, which will be increased as traffic demands.

## A STREET CAR CURIOSITY.

Double deck cars are by no means spring chickens in the street car family; but when one considers how few are in use in America today, there need be little wonder that some of the earlier types failed to multiply and possess the earth. Our illustration and the following description appeared in one of the current numbers of "Bellew's Pictorial," in 1855, the original of which is kindly loaned us by J. W. Fowler, president of the Fowler Car Company.

"The accompanying engraving is from a drawing made for us at New Orleans, by Mr. Bellew, and represents the horse car in use upon the City Railroad. It is unlike any employed at the north, and will doubtless prove interesting to our readers, now that the introduction of horse railroads here is a settled thing. It will be seen that it is intended for the accommodation of both outside and inside passengers; the entrance

cemetery; and even beyond it, in the direction of New Utrecht and Bath; while another railroad, at right angles with the preceding, connects Brooklyn with Williamsburg and Greensport. We have no doubt that within a few years many of our suburban villages, which are now served with omnibuses, will be connected with the city by horse railroads."

FARMER CHARLES KLUTZ went to Brooklyn, N. Y., not long ago to "see the town." By evening he became somewhat inebriated. Then starting for a little ramble, the agricultural gentleman came across the electric railway track. At the juncture a car came along with a whizz and a rattle of trolley wheels and gong. Klutz did not attempt to get off of the track and was hurled to the pavement. He was resuscitated an hour later at a police station, and declared to the justice that he thought it was the devil after him, in retribution for his spree.

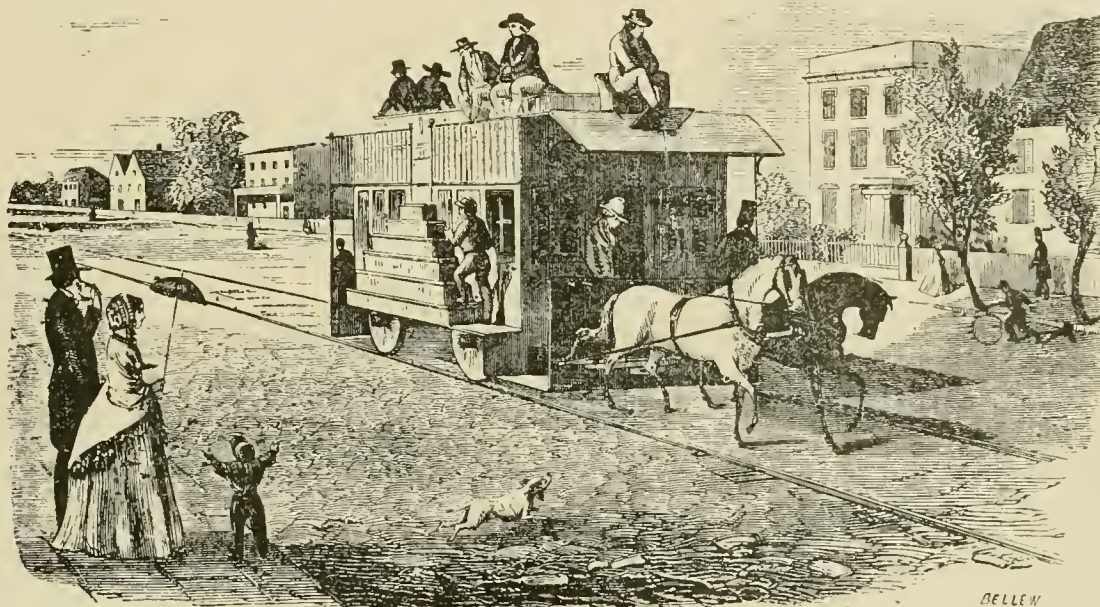

STREET RAILROAD CAR, NEW ORLEANS.

(Fac-simile of the illustration which appeared in Bellew's Pictorial in 1855.)

for the latter being at the extremities, as in the New York horse car, and the common steam car; while the upper deck passengers, as they may be termed, mount to their lofty station by a flight of steps, accessible from two sides. It is evident, that with no greater area than that of a common car, a much larger number of passengers can be accommodated, and in fine weather the roof seats must be quite pleasant. The introduction of railroads and horse cars into New York City was quite an event in the history of internal locomotion; and there, with the broad, rectangular streets, as in New Orleans, they have been found to work to a charm. The immense travel over the streets of great commercial emporiums, will always keep their surface full of irregularities, so that a passage over them in an ordinary conveyance reminds one of a run across a chop sea. All this jolting is avoided on the rail. The cars glide along as smoothly and as pleasantly as a row boat over a quiet stream. These channels of internal communication will be multiplied, till all the broad avenues of the city are occupied by them. In the city of Brooklyn, cars are running continually from Fulton ferry to Greenwood

## A REAL SCOOP.

Some people never would be satisfied. For, lo, these many days the papers have howled for a reliable safety fender, and all the inventors in the country sprang to their aid, and the host of fenders is like unto the sands of the sea, or unto car starters for number. Now they call the devices "scoops," yea, "trolley scoops," and the Bridgeport, Conn., Standard, says:—

One great advantage of this new device will be the less frequent stoppage of cars on account of accidents. When the scoop net has gathered in a lame old lady, a giggling girl, a skipping school boy, a myopic old man, and a bouncing baby, it can still continue on its course, giving the miscellaneous contents of its safety net a gratuitous ride, and at the end of the route the catch can be picked out, assorted, returned to its individual habit, or advertised in the lost and found columns of the daily papers.

THE past few month's eastern sales of the Ball engine do not seem affected by the hard times.

## WILLIAM RICHARDSON.

Almost since the inception of the American Street Railway Association, no form has been more familiar, and no voice more readily listened to, than that of William Richardson, the past president of the Atlantic Avenue Railway, of Brooklyn, the Nestor of American street railway men, and one of the best known figures in the public life of Brooklyn.

William Richardson was born in Berkhamsted, Hertfordshire, England, in 1822, but lived the first seventeen years of his life in London. Leaving school at the age of ten, he entered a barrister's office, where he remained seven years, doing an immense amount of reading and study while in this situation. In 1834, Mr. Richardson, his brother John, and their father came to America, and located in Ohio, subsequently going to Schenectady, and then to Albany, N. Y., where his first really active business career began. His twenty-five years residence in the New York state capital saw him interested successively as hotel clerk, umbrella maker, and wall paper merchant. In 1844 he married Miss Mary Freeman, the golden anniversary of which event is thus sadly precluded. Seven children were born of this union, four of whom survive, the best known being the secretary of the American Street Railway Association.

In politics Mr. Richardson took active part, and was a consistent and aggressive republican, holding various positions of state and municipal prominence, and serving the United States as additional paymaster in the U. S. army, at New Orleans, from 1861 to 1864.

The following year Mr. Richardson began the work to which we owe his presence in the street railway field, as director of the Dry Dock, East Broadway & Battery Railway, of New York City. A few weeks later he was made president, and the management devolved upon him. Trebling the receipts of the road, extensions followed, and in 1867 he leased the Brooklyn & Jamaica line, which was an uphill undertaking. However, in 1872, the Atlantic Avenue Railway was syndicated, and the story of this successful enterprise is one too well known to repeat, ending with the sale of the line last year, and its change to electricity. Mr. Richardson's

tremendous activity has thus continued to the very end. Naturally a powerful organizer and a fearless leader, he came out successfully from two of the greatest street railway strikes in the history of the craft, namely, those of March, 1886, and January, 1889. The title of "Deacon" was bestowed upon him by the daily press, for although he was always one of the most active members and workers in the Baptist church, he did not, however, hold the office mentioned.

Mr. Richardson has attended all the American Street Railway conventions since 1884, except the meeting of 1886, at Cincinnati, and has been usually accompanied by his wife and daughter. His keen observation and splendid knowledge of parliamentary usage has more than once steered a stormy business session around the rocks to a harbor of peace.

Whether serving the party of his political choice, or the government of his adoption, or the business interests with which he had connected himself, the same energy, tenacity and courage had been shown in every part of his career. As illustrative of this devotion to duty, in 1858 there was a tie in the house of representatives, of which he was clerk, and in the absence of that officer, speaker also. For six weeks Mr. Richardson sustained these two duties, but from the strain succumbed to a fever, which left his hair snow white.

He was, in truth, a remarkable man, of the cast of mind and character that makes strong friends and enemies, but all acknowledge his strength of

character, and ability and sterling worth. As an incident of the last convention, and as an evidence of the respect Mr. Richardson commanded, we recall the fact that when rising to respond to an unexpected call from the toastmaster, at the banquet, every one in the room instantly sprang to their feet, while the younger members started three rousing cheers, in which even the ladies and most dignified heartily joined.

THE Sabold Ground Rod is in use on five well known eastern roads and the result has been such that not only is there no trouble from electrolysis, but telephone troubles have been quieted. The latter is a strong argument as showing the efficiency of the system controlled by the National Electric Railway Improvement Company.



WILLIAM RICHARDSON,  
Born 1822. Died December 31, 1893.  
(From a photograph in February, '93.)



## PLEASURE RESORTS AND CREATED TRAVEL.

A Wild Ravine Becomes a Beautiful Park at Seattle—Cable Park at Cleveland.

### PART II.

From the description of resorts on the Atlantic coast and in the Mississippi valley, which engaged our attention last month, we now turn to the far West.

Here we find Seattle, which has become a large city, needing public parks, by such rapid strides that its municipal government has not yet been able to provide these breathing places for the people, except by making small

more plentiful than money, they gave it as a subsidy a tract of about twelve acres, forming a gulch at the Lake Washington terminus. On a knoll at the shore edge of this gulch the power house was built, with an incline running down to the water, up which the coal and wood are hauled, but for several years the remainder of the tract was left in its primeval wild condition. It was clothed with a dense growth of timber and brush, and the narrow level stretch at the bottom was a swamp, which the lake overflowed in winter.

It was in the year 1891 that the company began the work of beautifying this tract, and transforming it into a pleasure resort for the patrons of the road, under the direction of A. F. Haas, who was then and now is gen-



beginnings; but private enterprise has stepped in to fill the gap, and nobly has it done so. A striking feature of the city is the fact that this work has been undertaken by the street railways, and among them the Seattle City Railway Company has led the way, in laying out Leschi park.

The Seattle City Railway has the distinction of being the pioneer cable road of the Pacific northwest, and the second street railway built in the city of Seattle. Running from near the foot of Yesler avenue, on the side of the city fronting on Elliott bay, eastward on that thoroughfare to Lake Washington, a distance of two and a half miles, it turns back to Elliott bay, along Rainier street and Jackson street. The road was built in 1888, with the hearty support of the citizens, and land being then

eral manager of the road. He filled in the swamp until it was above high water, graded it, and laid it out as a flower garden, made a gentle slope of green turf on the north and south sides, cleared off the brush and fallen timber from the upper side to the west, and fenced in a deer park. To it he gave the name Leschi park, to commemorate Chief Leschi, who led the invading host of Kittitas Indians in their attack on Seattle in 1856, and who is reputed to have landed at this spot after crossing the lake. Since then the park has been improved, and its attractions have been added to, until it is now the most beautiful and most popular resort of the Sunday pleasure-seekers in the city. It looks out across the broad bosom of the lake towards Mercer Island, which stands midway between the east and west shores, and the rugged hills,

among which it rests form a beautiful setting for it. A large casino has already been built on the south side of the park, and this is now used as a skating rink, having floor space admirably adapted for the purpose. A tank has been fenced off on the edge of the lake, where four sea-lions disport themselves, to the delight of the lookers-on, who can view them at their ease from a covered pavilion. Close at hand are cages, where two bears, two coyotes, a South American puma, several monkeys, and paroquets, amuse the children. In a neatly fenced

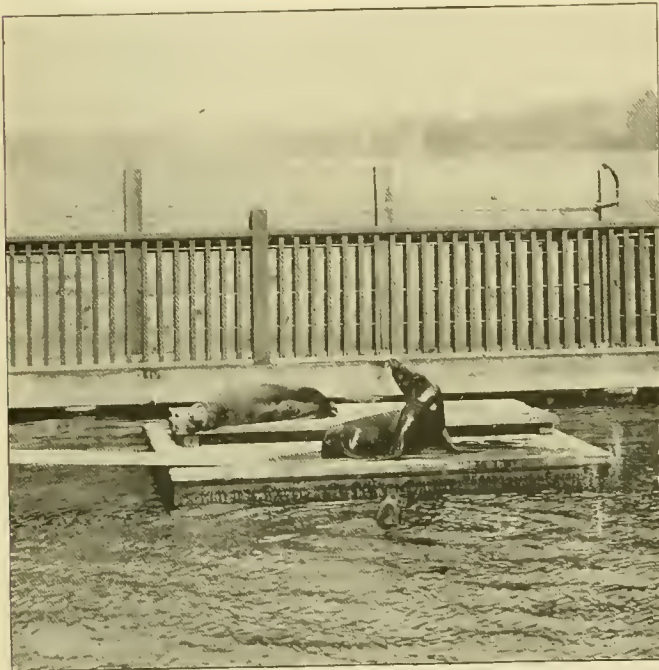

"Where the Sea Lions disport themselves."

enclosure on the hillside are five deer and two elks, captured in the Cascade and Olympic mountains, which form a glorious background to the view from the city on the east and west. Southward along the shore, a lovers' walk extends, under the shade of the trees. Opposite the center of the park is a boat house, where the taste of the most fastidious oarsman can be satisfied. Still further north is a swimming bath, with a toboggan slide, down which lovers of aquatic sports can plunge into the water. A high trestle, which formerly spanned the gulch, to carry the cable road over to Jackson street, has been cleared away, as it marred the beauty of the landscape, and its place has been taken by a number of swings. Rustic benches are scattered through the park, and a fountain sparkles in its center. Here a band plays on Sunday afternoons, and balloon ascensions and parachute jumps draw great crowds of visitors in the summer. Largely increased patronage has proved the wisdom of these expenditures and the appreciation of the people.

A large greenhouse furnishes the thousands of flowering plants, which border the walks or are massed in great beds of fragrant beauty. The REVIEW representative, writing these lines amid the rigors of a northern

winter recalls with unusual pleasure the monster bouquet of mammoth roses, which nearly filled his arms, and which were deftly assembled by an experienced horticulturist in response to Mr. Haas' instructions to that worthy to "bring a few flowers." The natural beauty of the place has constantly been added to, and the transformation which a few years has worked seems hardly possible. It stands today as one of the most beautiful spots on the Pacific coast, and its financial success is evidenced in the crowds which constantly throng the grounds.



A. F. HAAS.

Nor has the useful been forgotten. A steam pump of 1,000,000 gallons capacity per day, formerly raised water from the lake to a reservoir on the crown of the hill, which shuts in the park on the east, and from which a gravity pressure supplies the fountains, power house and other buildings, and affords ample fire protection, as well as irrigation. A beautiful spring now contributes to these same purposes, and the road is thus made independent of the uncertainties of the municipal supply, and obtains water at no expense beyond the initial cost of the plant. With cars running regularly every three minutes in summer and every five minutes in winter, the public has little to desire in the way of accommodation, while the provisions for comfort, pleasure and entertainment at the park are fully as complete. Both road and park are a constant testimonial to the enterprise and good management of Mr. Haas, who can boast of a resort equalled in only one or two instances in the country.

THE CLEVELAND CITY RAILWAY

has a resort at the end of its Payne avenue line, known as Cable park. It is just across Doan street from Wade park. Cable park is on the slope of a hillside, at the bottom

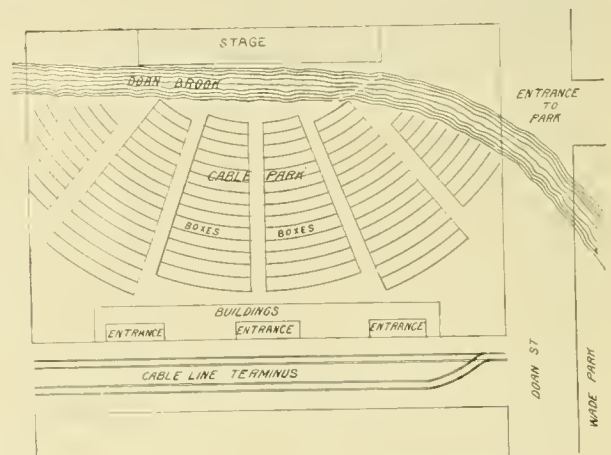

CABLE PARK, CLEVELAND.

of which is Doan creek. This hillside is used as an open air theater, the stage being put on the opposite side of the creek. The Fall of Pompeii, and shows of similar



nature, are the ones principally given. The creek was dammed up, leaving a waterway twenty feet wide by four feet deep between audience and stage. In the winter it is thrown open as a free skating rink. The theater seats are arranged in boxes, holding six to ten in a box. The cheaper seats are benches and chairs. Lemonade is the only refreshment served. Seating capacity of park 8,000.]

#### THE JAMESTOWN, N. Y., STREET RAILWAY

is making quite an extensive investment at Celoron, on Chautauqua Lake. They are laying out handsome grounds, and will do extensive building; the intention being to have the resort ready for next summer. President A. N. Broadhead is the prime mover in this scheme.

### BUCKING SNOW.

At the December meeting of the Massachusetts Street Railway Association, E. C. Foster gave some of the results of his experience with snow bucking on the Lynn & Boston Street Railway. They have at present 32 electric plows of their own design, which design they have used with slight modifications for four years. The plows they built this year had 36-inch wheels, with 2 1/4-inch tread and 3/4-inch flange. Two W. P.-50 motors are connected by a sprocket chain to the axle of the plow. They prefer a sprocket to direct gear because the plow is liable to strike an obstruction and break the gears. The cabs are 12 feet long, 6 feet high and 6 feet wide. They have some plows with F-30 motors giving good service, but the capacity of the F-30 is hardly great enough to operate a plow without burnouts. When there is little frost in the air it is not hard to keep the track clear in severe storms. Last winter they had a piece of double track over a mile long which was constantly kept clear by two plows equipped with W. P.-30 motors. The repairs were not five dollars for the winter. Frost and sleet are the elements of a snow storm that make trouble, and when these are present they are taxed to their utmost to keep things moving. They have run a plow for 36 hours continuously, without a mishap. They have also a rotary sweeper with four motors, two to propel it and two to run the brushes. The amount of snow it can remove is almost unlimited, but it is hardly fit to use on city streets. They operate about 100 miles of single track and 25 miles of double. Much of the single track is along one side of the street. It is desirable in the latter case to be able to throw the snow toward the center of the street the first time over, with the plow. In most of the cities and towns they remove the snow from half the street and the city removes the other half. The road is divided into three divisions, each having a superintendent. Each superintendent has a snow plow assigned to each route of his division, and the foreman of the station from which the plow is operated, is held to account for the clearing of the tracks and the running of the plow. This responsibility makes the men more faithful. There is special work, such as cleaning switches, for which special men

are detailed during storms. The snow removed from streets is dumped in abandoned cellars, on wharves, and anywhere they can secure permission.

C. S. Sergeant, of the West End, Boston, said that they had 250 miles of track and 150 miles of streets to be kept open. Of this, 182 miles are electric. Last winter they never lost a rail or were blocked on any electric or horse line, in spite of the fact that it was the worst winter for 27 years past. To accomplish this, there were 84 electric plows, enough horse plows for the horse lines, a large number of levelers, and 372 snow sleds, with such carts as could be hired, in addition. He considered, that to contend with snow, it was necessary first, to keep the equipment in perfect repair during the snow season; second, to have plenty of reserve station capacity for the extra power; third, to have an organized system whereby the work to be done in case of a sudden storm is laid out in detail in advance. The West End system is divided into nine divisions, in eight of which there are barns from which cars are run, the ninth being the central division, in which there are no barns, and which orders its plows by telephone from the other divisions. When a storm begins, men are sent out to keep clear the curves, switches and special work. A switch wagon on each division makes the rounds, salting curves, switches and grades. The system is so large that conditions vary greatly between the heart of the city and suburbs. For this reason a night inspector is kept in the central division, ready to order out plows and men at any hour. He had found it essential to follow the snow plows on electric lines promptly with levelers. In heavy storms, plows ought to be run on at least fifteen minutes headway. In the heart of the city a plow drawn by horses and having sharp-tired wagon-wheels gauged to fit the track had been used a good deal. With this the snow is plowed aside and the plow then is turned back alongside the track, to act as leveler, thus doing two classes of work. Early plows were all too light. Their standard plow now is very heavy, with the power transmitted by sprocket chains. The motors are in the cab. The plow has heavy iron-diggers, operated by the foot of the motorman. Chains and breakable parts are duplicated. They do not use a nose plow because most of the track is double and the snow is not allowed to get deep. The secret of keeping the road open is, to keep ahead of the snow. Hundreds of men and hired teams are called into use during a storm. Special snow paymasters are appointed, and they pay the floating laborers daily. The men are identified by the foremen and by the surrender of a shovel and identification ticket. The teaming work is also covered by tickets and reports. The expense of all this work is enormous, and the company is practically doing the city's work of cleaning while getting nothing for it. They found, however, that electric cars were much better than horse cars in winter, because the electric could more nearly keep up their regular mileage, and the receipts are reduced but little as compared to horse cars.

W. W. Sargent, of the Fitchburg & Leominster Railway, also speaks from a very practical standpoint. He

## Street Railway Review

with less than 50-horse-power. Lighter equipment can not do the work on 10 per cent grades such as they have. Their plows are 18 feet from dasher to dasher, with a 4½ foot platform, giving ample room for four bags of salt on each end and what sand is required. Each plow is equipped with four shovels, bars, brooms, oil, wrenches, fuses, waste, and bolts of different sizes, as may be required to make repairs. They use the sprocket chain, and like it very much. It has never given any trouble to speak of, and the motors are inside the cab, where they should be, in his opinion, as they are not exposed to the storm and are easy to get at in case repairs are needed. He would not advise anyone to use the S. R. G. under any circumstances. They use W. P.-50.

They use petroleum on trolley wire, and keep plenty of sleet wheels on hand in case of a sleet storm, which invariably gives them more trouble than snow. In very severe sleet storms, when the sleet wheels failed to work, they have been successful in removing the trolley wheels altogether, keeping men on the cars to hold the trolleys firmly against the wire, cutting the ice with the harps or trolley forks. He would not recommend doing this, unless it was absolutely necessary. They start men out to salt and sand all switches, curves, and railroad crossings, as soon as it begins to snow, and keep men at the railroad crossings shoveling snow and keeping the rails clear. No company can afford to take any chances of getting a car stalled on a steam railroad crossing. They do not depend on salt carried on the plows, any more than to touch up bad places, but have salt cars. These were fitted up



FITCHBURG & LEOMINSTER ELECTRIC PLOW.

thinks that many snow plows on the market are useless in a heavy fall of snow. There ought to be two 30-horse-power motors to a plow, and a cab covering the entire body of the plow, in which should be the resistances, cut-outs, etc. The practice of putting the motors in the cab and gearing them to the axles by sprocket chains is absurd. If a car with motors geared direct to the axles can perform its duties during a snow storm a plow certainly should. It is unquestionably the place for the motors, and the one in which they will prove satisfactory at all times. The cab can be used to store sand, salt and tools, and furnishes a comfortable place for the men. Sleet wheels have been mostly experimental, but there are some on the market that prove a decided benefit in sleet storms. In connection with this, the use of two trolley stands, one having the sleet-wheel and carrying no current, has proved successful. To successfully handle a storm, the equipment must be ready to turn out at any moment. Salt and sand in the proportion of one part salt to ten of sand should be distributed along the surface of the rails as soon as the snow is an inch thick. Track scrapers are a great help not only for sand and gravel but for snow and ice. Those having a spring attachment allowing for the motion of the car are a great advance over the old style. Promptness and celerity with a complete equipment always in repair, are essential in handling snow.

N. E. Morton, of the Lowell, Lawrence & Haverhill Railway, began with horse-plows eight years ago and so has been through the mill from one end to the other. He spoke, however, more especially of his experience with electric plows in the last three years. His lines had never been tied up; that is, cars had always kept very near schedule time. Every car should be equipped with snow scrapers. They use the Dorner & Dutton. Each car should also be fitted with sand boxes. The latter are especially useful when a car is sliding on hills. They use principally Ellis Car Company's nose plows, with shear plows for double track. No plow should be equipped



"The cab furnishes a comfortable place for the men."

from old one-horse cars, and are arranged to couple to a motor car. They have a spout on each side, in the center, carrying salt in one end of the car and sand in the other, so that either may be used as required. Two men inside the car feed the salt or sand into these spouts, which are directly over, and within six inches of the rails. They always start the leveller when it has snowed about six inches, so as to keep the ridges back, and give the plows a better chance to throw back the snow. This also pleases the traveling public much better.

George F. Reed, of the Springfield Street Railway, agrees with the others in regard to the necessity of an early start. He had used a plow with a heavy nose of boiler iron, which gave very good results. One strong point was its weight, which gave good traction.

### MOVING HOUSES OVER RAILWAY TRACKS.

The Relative Rights of Companies and House-Movers.—The Municipal and Unwritten Law in Various Cities.

The average house-mover is about as obstreperous and irresponsible a nuisance as any which crosses the path of the much-abused manager. Of all individuals which assume to possess the earth, with the least actual inheritance against which damages are worth collecting, the house-mover is chief. With him, possession of one's tracks seems even paramount to law. Like a thief in the night, he stealthily pulls some worthless old hulk of a building from out the least suspected hiding-place, and daylight and the first tripper finds him on the street with windlass broken and horses and men exhausted. But he studiously avoids any anxiety or excitement provocative of heart trouble; he leaves all that for the manager, and complacently sits down on a wooden roller to rest and smoke, while the cars gather like snow-flakes and stretch out in what seems an eternity to the manager. The public profane violently, while a crew from the company's barns tackle the unaccustomed job, and in two or three hours have the wheels of commerce again in motion.

The blockading of tracks under the old horse regime was quite bad enough, but when it comes to cutting trolley lines and perhaps several heavy feeders, difficulties are by no means lessened. That there should be some legal protection, or what is better, suitable legal prevention, in every city, is obvious; not alone to save the company from loss entailed in repairs and travel, but to protect the thousands depending on the cars for transportation and to many of whom a late arrival at place of employment means the loss of a part or whole of the day's wage, or even loss of position. From every standpoint justice and equity declare to place very stringent restrictions on the house-mover, and it is with a view to pointing out in what way this may be accomplished that this article is written, and the views of many of the leading managers in the country kindly contributed.

Our investigation reveals the fact that what is a serious burden in one locality does not exist in others. This is explained by the reason that in some older cities few houses are moved, and in others frame buildings are a rarity. But these are the exceptions. We also find that while injunctions are generally available, there is little municipal law requiring movers to first secure consent of companies, and all know that when a building is once on the tracks, an injunction is the last and least helpful remedy, as what is then imperative is something to expedite and not delay movement. Movers avail themselves of this fact and usually carefully conceal their intentions

even where permits must be secured from some city official, and as stated, make their debut by getting in the way. Whether a mover can legally compel a company to cut its wires is a nice question of law, which will be discussed later.

AT INDIANAPOLIS.

General Manager McLean reports that a number of instances have occurred in this city, where houses have been moved across or along the line of electric roads. In each case permission was first obtained from the department of public works, and the consent of the railroad company was asked also, and obtained. The latter being given on condition that the house should only be moved upon or along the lines between the hours of pulling in the cars at night and pulling out in the morning. There is no city ordinance relating to this subject, but the board of public works has assumed control as above.

"In one instance, I am informed, where a house being moved prevented the operation of the line, compensation was awarded the railroad company for the delay."

DETROIT.

In the matter of cutting electric wires by house-movers, the common council about a year ago granted permission to a house-mover to move his house over the tracks of the Fort Wayne & Belle Isle Railway Company. The railway company applied to Judge Hosmer, one of the Circuit Judges, for a temporary injunction to restrain the house-mover from interfering with the wires of said company. The city counselor moved to dissolve the injunction, and his motion was denied by the court, which left the temporary injunction as against the city, valid. The case has never come to trial, but a temporary arrangement between the board of public works and both railway companies has been entered into, pending the making permanent of this injunction, or its denial altogether, by which said board of public works will not issue a permit to a house-mover to cross the tracks of any electric railway company, without first receiving consent of the railway company, and with the understanding that a sufficient bond or other security be put up by the house-mover, indemnifying the railway companies against any loss or damage that may result from cutting of the wires. The usual way is for the company's men to attend to the cutting of the wires and replacing them, when a house is being moved across the tracks, and render a bill for actual cost of material and labor rendered.

LOUISVILLE.

General Manager Minary says: "I regret very much we have no protection from city ordinances in reference to moving houses, which has at times caused us considerable annoyance, but we have been able to lessen this somewhat by protesting against the road being blockaded, unless they would do it at such a time and in such a manner as to cause us the least inconvenience."

"I am glad to see the matter being agitated, and I hope we will have, at some time, suitable ordinances regulating the matter."

## MINNEAPOLIS

has a protective ordinance which, says General Manager Field requires a house-mover to procure a permit from the company, and before this is granted he must make a deposit sufficient to reimburse whatever expense is incurred by the company. The ordinance reads as follows:

"In case the removal as permitted by the inspector of buildings requires the removal or displacement of any overhead electrical wires, such permit shall not be construed as allowing any removal of such building until permission is first obtained from the person or company owning or operating such electrical wires, or from the City Council.

Provided, that no building shall be permitted to be moved across any steam or street railway tracks except between the hours of one and five o'clock a. m."

## DENVER.

"There is no city ordinance here at present," says Superintendent Durbin, "which regulates the moving of houses under electric wires, but we are told by the building inspector that such matters are left entirely to his judgment, and that when a party wishes to move a house, he sends him to the electric companies to get their consent.

"The building inspector intends to introduce an ordinance relating to the matter within a short time, and we expect to have something to say about it. Up to date we have been bothered but little, probably for the reason that most of the houses here are of brick, and there is comparatively little moving. Several times, however, we have been called upon by parties wishing to move houses under our wires, and have sent our linemen out to assist; but I do not remember of a single case where it was necessary to cut the wires. The building inspector assures us, that should any person attempt to cut our wires or otherwise interfere with them we would have a right to have him arrested. We think the question an important one for street railways, and are glad the matter is being taken up."

## AT ALBANY,

General Manager McNamara has had his share of woe, and in relating his experience takes the radical, and it would seem logical, view that the moving of a house into the street is a trespass, and he contributes the following:

"While operating our lines as horse-car lines, we were very much annoyed by the movers of buildings. The annoyance became unbearable, not only to us but to the traveling public, and we served notice upon all movers of buildings that we would tolerate the custom no longer. The principle upon which the writer proceeded was, that the streets were highways, and the moving of buildings thereon was an obstruction of the highway. Buildings cannot be moved without disturbing the pavement of street and without laying special ways or tracks upon it to move them. These facts demonstrate that the moving of buildings on highways is a use of a street or highway never contemplated by law, and a use which has only been tolerated. After we gave notice to the movers of buildings, as above stated, upon special application we made arrangements for buildings to be moved across our lines at night, but never in the day-time. Since we have operated by electricity and put up wires, only two build-

ings have been moved, one across one of our unimportant lines and near the terminus of the line, which did not involve the cutting of our wires, and another which rendered the taking down of a pole necessary, in order to enable the mover to get his building around a corner. In the latter instance, we insisted upon being paid the amount necessary to take down and put up the pole.

"There is no city ordinance in Albany in relation to the moving of buildings; that is, there is no specific ordinance permitting or prohibiting the moving of buildings. We are quite positive that if an attempt should be made to move buildings in such manner as to obstruct our tracks, we could procure an injunction and prohibit the moving."

(To be continued.)

## THE HESS STORAGE BATTERY.

This battery, which has recently been put together, at Springfield, Ohio, has the active material entirely surrounded by a porous material, to keep it in place. Each electrode consists of two plates, between which the active material is placed. The plate is then covered with the

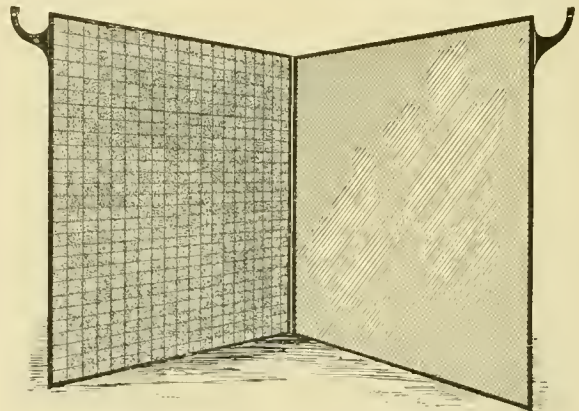

"Each Electrode consists of two plates."

porous substance, so that there is no metal exposed except next to the active material between the plates of each electrode. The electrodes are separated by rubber strips. These rubber strips are held in place by lugs on the plates. The porous material, which is the peculiar characteristic of this cell, is said to offer no resistance other than that in an ordinary battery. It is composed of sand, and a composition for cementing the particles together. The inventor is F. K. Hess, of Springfield, O.

DURING the past year, one of the notable business successes has been the Safety Brake Shoe Company, of 620 Atlantic avenue, Boston. Although not yet a year old, the volume of business of the concern has increased fifty per cent every month, and duplicate orders testify as to the esteem in which the brake shoe is held. A Pacific coast agency, under Edwin W. Tucker, 130 Main street, San Francisco, will manufacture and sell to the coast states. Agencies will also be established at Chicago and St. Louis.

## STREET RAILWAY EVENTS OF 1893.

### JANUARY.

Last horse car runs in Toledo, January 1. Motors displace Madison, Wis., mules, January 1.  
 William Richardson, president of the Atlantic Avenue Railway, Brooklyn, retires.  
 Col. N. H. Hefl gains control of the Bridgeport, Conn., lines.  
 Connelley Gas Motor started in Chicago.  
 Tiffin, O., plant burned January 16.  
 People's Traction Company, Philadelphia, succeeds the People's Passenger Railway.  
 Amalgamated Association of Employes, at Cleveland, dies.  
 Power house of the Central Railway, at Peoria, burns January 16.  
 Temporary power house started in ten days.  
 Seattle Consolidated bought by F. T. Blunk and associates of Davenport.  
 H. M. Littell goes to the New Orleans Consolidated.  
 McMahon ammonia motor reappears in New York.  
 McKinley syndicate buys the Bay City and West Bay City lines.  
 STREET RAILWAY REVIEW celebrates its second birthday.  
 W. A. H. Bogardus elected secretary of the Brooklyn City Railway.  
 Enlarged Jefferson street cable plant of the West Chicago Street Railroad started.  
 Third annual meeting Massachusetts Street Railway Superintendents' Association, January 27.  
 Constance Crimmins starts the Broadway, New York, cable, Jan. 31.

### FEBRUARY.

Liverpool, Eng., Overhead Railway (electric), opened February 4.  
 New York, New Haven & Hartford begins fight against Massachusetts interurban trolley lines.  
 Coal famine from railroad snow blockades in many parts of the country. Snow storms of unusual severity make great trouble for managers.  
 Fly-wheel bursts in power-plant of the Union Depot Street Railway, St. Louis.  
 Street Railway Gazette bought by the Street Railway Journal.  
 New Metropolitan Traction Company, with John D. Crimmins as leader, buys 140 miles of track in New Jersey.  
 Opening Main Street Railway, Jacksonville, Fla., February 23.  
 Rapid Transit Committee, Massachusetts Legislature, visits Chicago February 25.

### MARCH.

Love conduit started to operate on the Rock Creek Railway, Washington, D. C., March 1.  
 Wheelless conduit system put in operation on the Washington & Arlington Railway, Washington, D. C.  
 Edward G. Gilbert, Troy, died March 9.  
 J. L. Valentine, secretary North & East River Railway, New York, died March 13.  
 McKee-Verner syndicate of Pittsburg gains control of the Indiana polis Citizens' Railway and elects new officers.  
 D. A. Andrews, of Pettingell-Andrews Company, died.  
 Broadway and East Cleveland Roads combine.  
 South Chicago City Railway opens.  
 H. W. Fordyce elected president Little Rock Electric Railway.  
 Grade crossing ordinance passed in Chicago.  
 Green trolley patents bought by General Electric Company.  
 Richmond Railway & Electric Company buys the Richmond & Manchester.  
 New England Street Car Company formed by a syndicate of prominent capitalists.  
 Chicago & North Shore commences to build.

### APRIL.

Rail welding tried on the Lynn & Boston.  
 Los Angeles & Pasadena Electric contracted for.  
 Henry C. Moore succeeds Robert N. Carson as president of the Peoples' Traction Company, Philadelphia.  
 F. M. Smith, borax king, consolidates Oakland lines and fulfills the REVIEW's prophecy.  
 New power plant Peoria Central Railway started.  
 Intramural elevated electric opened at Jackson Park.

### MAY.

World's Fair opened May 1.  
 Lake Roland Elevated opened at Baltimore May 2.  
 Car barn of Grand View Beach Electric Railway, Rochester, destroyed by fire May 11.  
 First car over entire route of Broadway, New York, cable, run May 13.  
 First electric railway in South Carolina started at Columbia.  
 Orange Mountain (N. J.) cable started.  
 Moses G. Farmer died May 25.  
 Chicago City Railway electric plant starts.  
 Russell Harrison syndicate gets control of roads at Richmond, Ind., and Michigan City.

### JUNE.

Twin City Rapid Transit Company (Minneapolis and St. Paul) voluntarily raises conductors' and motormen's wages.  
 Cleveland City Cable and Woodland Avenue & West Side Railways consolidate June 1.  
 Niagara Falls Park & River Railway opened to traffic.  
 Ferris wheel dedicated June 21.  
 The Concord, N. H., Street Railway opened to traffic June 16.  
 Pittsburg, Allegheny & Manchester Street Railway absorbs the Pleasant Valley Traction and the Allegheny Traction Companies, June 14.

### JULY.

The Moving Sidewalk started July 1.  
 Mineral Ridge & Niles, O., Interurban elects officers and goes to work.  
 Many street railway men visit the World's Fair and the REVIEW.  
 Hartford & Wethersfield Street Railway authorized to change from horse to electricity.  
 Alton, Ill., elects officers for its electric line for the first time.  
 Reorganization of the Greencastle Street Railway is effected.  
 Cold storage fire at the World's Fair grounds threatens the intramural railway.  
 Toronto decides against Sunday street cars.  
 Cleveland City Railway elects officers.  
 H. H. Vreeland succeeds John D. Crimmins as president of the Metropolitan Traction Company.  
 John Stephenson died July 31.

### AUGUST.

Mobile's street railway began operations August 10.  
 The Union Depot, the Mound City, and the Benton Belle Fontaine Street Railway Companies unite at St. Louis.  
 Milwaukee Street Railway Company organized out of the old Hinsey line.  
 O. S. Buckbee, of Seattle, Wash., retired August 1, from the presidency of the Yesler Avenue Cable Railway.  
 The Maine State Street Railway Association was formed August 15, by ten Maine roads. The first annual meeting was appointed for February.  
 Bellaire, Bridgeport & Martins Ferry Electric Railway opened August 29.  
 R. D. Nuttall died August 29 at Allegheny, Pa.

### SEPTEMBER.

The Pennsylvania Street Railway Association holds its second annual meeting at Harrisburg, September 6.  
 The great Air-Ship Pennington scheme for a Chicago and Central Indiana Electric Railway falls very flat. Pennington disappears from view once more.  
 Transportation Day at the Fair celebrated September 9, by a grand parade of all the transportation exhibits, together with a display of all the chivalry of "street car" row.  
 The London Omnibus Company's barns were destroyed by fire September 16; loss \$150,000.  
 New York State Convention held its annual meeting September 19, at the Hotel Powell, Rochester.  
 Ohio State Tramway Association meets at Cincinnati, September 27.  
 Judge Reinohl, president of the Lebanon & Annville, Pa., Electric Railway, died September 24.  
 Tug-of-war, Railroad Day, at the World's Fair, between electric and steam locomotives; result is victory for steam, Saturday, September 16.

## OCTOBER.

The STREET RAILWAY REVIEW is announced as a medal-winner at the World's Columbian Exposition.

Erastus Wells, the first street railway builder in St. Louis, died October 4.

The Canadian Electrical Society holds its annual meeting and is entertained by Niagara Falls Park & River Railway.

Chicago Day at the World's Fair brings three quarters of a million people into Jackson Park, and 2,535,915 fares into the coffers of the surface and elevated roads of Chicago.

On October 11, a 700 horse-power engine ran away in the Atlantic Avenue, Brooklyn, power house, bursting a fly-wheel and killing several persons.

The Chicago City Railway suffers a fire at the Wallace street barns; 461 horses perish; loss \$108,000; October 12.

All the San Francisco cable railways unite as the Consolidated Market Street Cable Railway Company, capitalized at \$18,750,000.

October 19, 20 and 21, at Milwaukee, Wis., the American Street Railway Association held its XIth annual session. Henry C. Payne elected president, and Atlanta, Ga., named as the next place of meeting.

October 30 the World's Fair closed and demolition began.

## NOVEMBER.

November 1, the East Side Street Railway Company, of Portland, suffered an accident, the electric car Inez going into an open draw. Seven persons were lost.

November 1, the Ohio Vestibule Law goes into effect and many street railways are considerably inconvenienced.

November 4, the Lake Street Elevated, of Chicago, opened for traffic, with due ceremony.

Anthony Reckenzaun died November 11.

Samuel Little is elected president of the West End Street Railway Company, of Boston, vice William M. Whitney, resigned.

Charles A. Schieren is elected mayor of Brooklyn.

Business depression culminates in several failures of street railway companies both east and west.

November 10, first royal electric mail service begins at Toronto, Canada.

The "trolley boat" makes its debut on the Erie canal November 28.

Robert Young, of the Glasgow Tramway, dies November 16.

Stephen Wilcox dies November 27.

The first snow storm in the Central States shuts off street traffic November 30.

## TRANSPORTATION IN LONDON.

Stephen Sellon, in *Lightning*, points out that it is impossible to accommodate all classes of passenger traffic in London by underground or elevated roads. The time made on underground roads in London is not much greater than on American street railways, when the time taken in walking to stations and ascending stairs is taken into account. In Mr. Sellon's opinion, the key to the situation is in the building of plenty of electric surface roads. Underground and elevated roads are too expensive for extensive use. The main present objection to surface tramways is the crowded condition of the streets, but a thorough tramway system would, to a great extent, diminish the crowd. There would be no more omnibuses to wear out pavement and obstruct travel, as the tramways would monopolize the traffic.

## MEDALS FOR INVENTORS.

The officers of the Franklin Institute, of Philadelphia, desire to call attention to the fact that the Institute may grant certain medals to the inventors of devices contributing to the promotion of the arts and manufactures. These medals are three in number, and are granted from time to time, as the Institute sees fit. Further information regarding the awarding of these medals can be obtained from William H. Wahl, the secretary, Philadelphia.

## ELECTROLYSIS AT MILWAUKEE.

The photographs of the pipes referred to in Mr. Rau's paper on electrolysis, in the December REVIEW could not

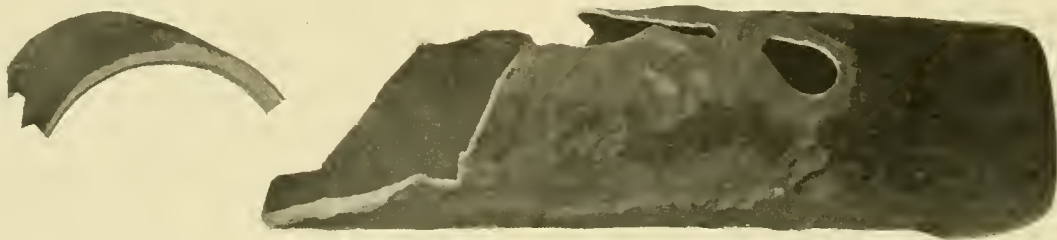

ELECTROLYSIS AT MILWAUKEE.

## DECEMBER.

December 1, the Philadelphia Traction Company, having completed its lines on Thirteenth and Fifteenth streets, made a trial trip.

Third Avenue Cable line, New York, started, December 4.

The Sioux City electric lines and cable railway consolidate as the Sioux City Consolidated, December 13.

December 16 the first car runs over the Jersey City & Newark, N. J., interurban line, carrying distinguished party of interested people.

Judge J. J. Jacobs, of the Wheeling, W. Va., Street Railway Company, died.

The STREET RAILWAY REVIEW reviews the year with its advertisers. December 21, the Altoona & Logan Valley power house destroyed by fire, loss \$25,000.

George H. Babcock died December 21.

Engine fly-wheel of the Des Moines, Ia., street railway power plant engine bursts, December 23, wrecking the building.

The fifth scheme for North Side rapid transit comes to light in Chicago and one gains a franchise.

William Richardson, Brooklyn, dies, December 31.

be obtained in time for that issue, and are accordingly presented herewith. They show the special action that took place at the point on the pipe nearest the wire. The reference can be found on pages 768 and 769.

For some reason or other the Melbourne, Australia, judicial conscience is very tender, and the public sentiment much against stealing, even stealing street car fares. Recently a conductor in the afore-mentioned city, failed to register three fares. An inspector discovered the discrepancy and the accused was haled before the bar of justice, to receive a month's imprisonment. The city papers made long notices of the offense, and seemed to think the punishment a just one. The judge in sentencing, characterized the offense as a most contemptable one.



THE MOUSAM RIVER RAILROAD.

A Pioneer in What is Destined to be an Important Field.

The time is rapidly approaching when an increase of the street railway mileage within the limits of our cities and towns will cease to be profitable, except as it accommodates the natural growth of the cities. This limit will not be reached for some years to come, and until nearly all horse roads have changed to electricity; but that being done, electric railway constructors must look to new fields, if they are to keep up their present activity. The most promising of these fields is the connection of the smaller country towns with the steam railroads.

The Mousam River Railroad, connecting the town of Sanford, Maine, with the nearest steam road, has the

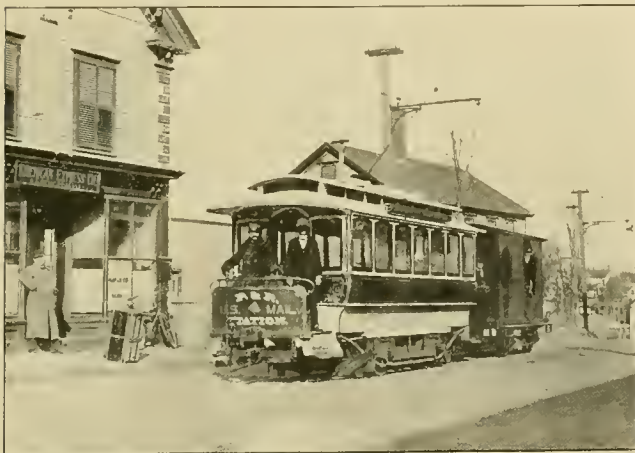

EXPRESS CAR AND OFFICE.

honor of being a pioneer in this field. It is both a freight and passenger road, hauling all the supplies for the town of Sanford, which has a population of about 5,000, and is quite a manufacturing center. The distance from the Sanford mills to the freight station on the Portland & Rochester Railroad is one and three-fourths miles. The entire length of the electric railway is about three miles. Passengers are carried from Sanford to Springvale, a passenger station on the Portland & Rochester.

The track construction is exactly the same as that of a steam road with moderate traffic, and was laid under the supervision of Jed Morrill, master mechanic of the Portland & Rochester Railroad. Sixty-pound T rail is laid on cedar ties, two feet between centers, and ballasted with gravel. Bonding is Number 0 copper, and copper plates, six feet square, and sunk six feet in the ground near the river, assist in the ground return. Lock switches as used on steam roads were laid throughout. There are in all, four iron bridges over the river. The trolley is hung in mile sections, on brackets fastened to chestnut and hard pine poles. Cars were built by Briggs of Amesbury, Mass., and are models of neatness and strength. Ahearn electric heaters are used. There are two box motor cars, two open trailers, and two baggage and express trailers. The trucks were built by Bemis, of Springfield, Mass., having sand boxes that find special

favor with the management, and Dorner & Dutton track scrapers. The two motor cars have each two 20-horse-power Westinghouse motors. The expense for repairs on cars and motors since the road started, about March 1, 1893, has not been over four dollars.

THE ELECTRIC LOCOMOTIVE.

As was mentioned before, the entire freight for the town of Sanford and its mills goes over the Mousam River Railroad. The electric locomotive is of great interest, as it is probably the only one in the world working under such conditions. It consists simply of a truck with 4-inch axles; properly housed over, and carrying two standard 30-horse-power Westinghouse motors. The wheels are 36-inch. It weighs 10 tons, 100 pounds, and is 27 feet from end to end. The cab is heated and lighted by electricity. This locomotive has been in daily use since February 28, 1893, giving excellent results. The maintainance account for it, including oil, brushes, and turning down one commutator, has been \$8.64. It hauls four loaded cars of coal up a 5 1/4 per cent grade, each car holding about seventeen tons. It has started at one time 10 1/2 tons. Sand boxes and a bell, a la steam locomotive, are a part of the outfit. There are also track scrapers and pilots, one of wood and one of iron, for plowing through snow. In big snow storms a snow plow, similar to that used on eastern steam roads, is put on. This will, according to Mr. Day, the superintendent, take care of any snow storm. It is not suited to city use, however, where the paving is high.

To get some idea of the work this locomotive has to perform, it will be necessary to investigate the

FREIGHT TRAFFIC,

which is taken care of almost entirely by it, the baggage and express being hauled behind passenger cars. At Sanford are located the famous Car Plush and Worsted Mills, employing under favorable administrations, 1,800 hands. These alone require the delivery of 300 tons of coal at the boiler room doors every day. In addition to this there is the local work for the grocery stores, etc., of Sanford, which showed an average of forty tons per working day, from March 1 to November 1, 1893. The locomotive mileage from February 28 to August 1



was 3,748 miles, nearly 30 miles per working day. Thus it will be seen that it is no light work that this locomotive has to perform. A regular price per ton is received for hauling and delivering coal to the mills. It is very much cheaper than the old way of hauling by wagon, and the management wonders why more mills in the state do not haul their coal in this way.

In addition to freight, which is hauled and delivered to any part of the city, the mail, express and baggage is brought from the railroad in the two trailers made for the purpose. The passenger business amounted to 111,725 in the eight months, March 1 to November 1, the highest record being 21,559 in July. The July freight business also was the largest during the period. The combination

#### WATER AND STEAM PLANT

has one 70-horse-power Corliss engine and one 150-horse-power Humphrey waterwheel. The engine has a 14-foot fly wheel and the waterwheel one of 10-foot diameter. The latter is also fitted with a Pritchard electric governor. The peculiar feature of the station is that the waterwheel and engine are run at the same time. In this way the engine takes care of a great deal of the irregularity of the load, for as the current increases, the



cold water, bath room, three pits for repair and inspection and two tanks 14 inches diameter and 6 feet high, furnishing water for fire purposes here and in the engine room.

#### THE MANAGEMENT

consists of Hon. E. M. Goodall, president; Louis B. Goodall, treasurer; and Everett K. Day, superintendent. Hon. E. M. Goodall is also president of the Sanford Mills. He has had a wide business experience and is respected by all with whom he has to do, as a gentleman upright in



THE ELECTRIC LOCOMOTIVE, MOUSAM RIVER RAILROAD.

waterwheel dynamo drops its speed and voltage, and the engine dynamo has an opportunity to deliver a greater proportion of current, so keeping the load on the waterwheel nearly constant. The coal bill is very light. The two generators are Westinghouse 100-horse-power. The switchboard is of skeleton style, made of bird's eye maple. In the stock room, where, is also the engineer's office, a full supply of duplicate parts is kept. The car house is 40 by 40, with slate roof, and two tenements on the second floor for engineers. It is supplied with hot and

all business relations. Treasurer Louis B. Goodall, is a brother of the president and well known as the treasurer of the Goodall Worsted Company. Everett K. Day, superintendent, is an electrician thoroughly in love with his work. His electric career began in 1889, and he has held positions of trust with various electric railway and light companies, and with the Thomson-Houston Company. Socially he is a man of rare good character and very popular with his subordinates.

The road is purely an investment property and was

built to earn money and not to boom stock. The stockholders were well acquainted with the conditions under which the road was to operate and acted accordingly. It would certainly seem that the management is right



E. M. GOODALL,  
President M. R. R. R.

EVERETT K. DAY,  
Superintendent M. R. R. R.

in expressing the sentiment that there are many rich fields for investments of this character, scattered over the country, and especially in Maine.

**BROOKLYN BRIDGE AFFAIRS.**

For the past year the Brooklyn Bridge earned \$1,252,908, of which amount the railway paid \$1,167,497. The number of passengers carried amounted to 41,772,898 in 1892, and 42,615,105 in 1893. On the bridge, 105 accidental injuries have occurred, mainly from falling down stairs. Two sudden deaths occurred on the bridge. Six lost children were found. From the opening of the bridge to date, 304,000,000 passengers have crossed. A delay account shows that the time lost from all causes amounted to 4 hours 35 1/2 minutes.

**REWARDS AT ROCHESTER.**

The annual distribution of \$1,000 among the most proficient motor-men and conductors has been made. The classes are first, second, third and fourth, for both motor-men and conductors. The first class is awarded \$10.00 each; the second, \$7.50; the third, \$5.00; and the fourth, \$2.50. One hundred and sixty men shared in the distribution.

**MOUSAM RIVER RAILROAD.**

ABSTRACT OF FOOTINGS OF FREIGHT WAY-BILLS.

Station.							Month of _____ 189						
FREIGHT RECEIVED.							FREIGHT FORWARDED.						
From _____							To _____						
DATE OF WAY BILL.	NO. OF WAY BILL.	WEIGHT.	FREIGHT CHARGES.	ADVANCED CHARGES.	AMOUNT PREPAID.	AMOUNT TO COLLECT.	DATE OF WAY BILL.	NO. OF WAY BILL.	WEIGHT.	FREIGHT CHARGES.	ADVANCED CHARGES.	AMOUNT PREPAID.	AMOUNT TO COLLECT.

**SYRACUSE FAILURE.**

On petition of directors the Syracuse Consolidated Street Railway Company went into P. J. Mack's hands, a receiver, last month. The company was the consolidation of twelve former lines. The bonded indebtedness was \$1,250,000. Cleveland parties are largely interested in the deal, but New York capital was the most active in bringing about the receivership. The syndicate paid \$2,500,000 for the stock of the component companies. On November 1, the floating indebtedness of the company reached \$180,000. The principal creditor is T. H. Conderman, of Philadelphia, for \$100,000 advanced since January, '93. The remainder of the floating debt is for supplies, taxes, wages and running expenses. The company operates 17 3/4 miles of track electrically and 16 1/2 miles by horse power.

**TEXAS STATE ASSOCIATION.**

A second meeting of Texas street railway men has been held at Waco, and a temporary organization formed with the title, "The Texas Street Railway Association." A. Zintgraff, of Denison, was elected president, and S. A. Hobson, Waco, secretary. A meeting to effect a permanent organization will be held at the Driskill Hotel, Austin, on January 24.

**PHILADELPHIA TRACTION COMPANY ADOPTS THE BEMIS TRUCK.**

The Philadelphia Traction Company has the reputation of being not only hard to please, but insists on a high quality of workmanship as well. Hence the selection by that company of the Bemis truck, made by the Bemis Car Box Company, of Springfield, Mass., and the placing of an immediate order for 300 trucks, is a recognition of merit in which the Bemis Company very naturally takes much pride. Mr. Bemis is probably the veteran street car truck builder in this country and combines experience and good judgment in his appliances.

**POSTAGE STAMP TICKETS.**

To the getting up of new schemes for the zone system of railways and tramways there seems no end. It is stated that a new plan of railway tickets is about to be adopted in Hungary, where the zone system has apparently met with some success. The traveller will make out his own ticket, and the government will sell railway stamps and supply blank cards. The passenger will, when he desires to take a journey, write on a card the name of the starting-point and destination, and affix as many stamps as the published list of fares calls for.

## STREET RAILWAY LAW.

EDITED BY MR. FRANK HUMBOLDT CLARK, ATTORNEY AT LAW, CHICAGO.

*Street Car Passenger Injured at Railroad Crossing.*

A passenger on a street car, which has stopped at a railroad crossing to permit a locomotive to pass, is not bound to be on the lookout, when the car starts, for another approaching engine.

The following is from the opinion:—The Court instructed the jury: "If Michael O'Toole upon that street car could have seen the engine and did not undertake to see it, and did not exercise reasonable care for the purpose of ascertaining whether they could proceed across the railway track in safety, then he was guilty of contributory negligence; and if, by looking up the railroad at that time, he could have learned whether an engine was or was not approaching, and could then have gotten off the car, if he discovered an engine approaching, and did not do that, then he was guilty of contributory negligence and cannot recover." Then further on in this instruction: "Had the plaintiff been walking in the street, the fact that the gates were not lowered would not be an invitation to him to cross the railroad in violation of the rule of law that he shall stop, look, and listen before crossing a railroad; and that rule is not taken away because the plaintiff happened to be in a street car."

We find no evidence which warranted this instruction. Plaintiff was a passenger of the street car company which had contracted to carry him safely. He had the right to presume that it would exercise all care required in this undertaking. When the car approached the crossing, it stopped; he was in no danger then, and had no reason to apprehend any. When it started, he had the right to believe that it did so because the crossing was clear. Running a distance of about seventy-five feet, the collision occurred. In the very few seconds which were necessary to accomplish this distance, the Court, in substance, instructed the jury that it was plaintiff's duty to be on the lookout to learn if the railroad track could be safely crossed, and if by so doing he could have seen the approaching engine, ordinary care required him to jump off. To impose such a duty upon a passenger under these circumstances, is going much further than any court has yet gone. The instruction, in substance, that ordinary care required plaintiff to perform the duties of conductor and motor-man; that practically he was to exercise the same care as if he had been driving his own horse—"stop, look, and listen"—was erroneous, and calculated to mislead the jury.

The cases of *Township of Crescent vs. Anderson*, 114 Pa. St. 643, and *Dean vs. R. Co.*, 129 Pa. St. 514, cited and relied on by appellee as sustaining the instruction complained of, really recognize the opposite doctrine. Both are cases where the plaintiff, when injured was riding in a private vehicle driven by another, and both were injured by the negligence of the driver and a third party—the defendant. In both, the decision was put on the ground that the negligence of the driver was apparent, and he was to some extent under the direction or

control of the party injured. There was no attempt, by remonstrance or otherwise, by the party injured, to restrain the negligence of the driver. The negligence of the driver was not in either case imputed to an innocent plaintiff, but the plaintiff was held to have participated in the negligence which caused the accident. *Borough of Carlisle vs. Bisbane*, 113 Pa. St. 544, is to the same effect; and the decision is expressly put upon the ground that, although the conveyance was a private one, the injured party did not to any degree participate in the alleged negligence of the driver. The plaintiff here was a passenger in a public conveyance; he conformed to the rules of the company; he relied on the vigilance and care of those in charge of the car, as his contract gave him the right to do. There was upon him no duty of moving the car with caution at dangerous crossings; no duty to watch for possible collisions and jumping off in apprehension of them.

(Supreme Court of Pennsylvania. *O'Toole vs. Pittsburgh & Lake Erie R. Co.*, 27 Atlantic Reporter 737.)

(NOTE—Imputable contributory negligence which will bar the plaintiff from recovery, exists when the plaintiff, although not chargeable with personal negligence, has been, by the negligence of a person in privity with him, and with whose fault he is chargeable, exposed to the injury which he received through the negligence of the defendant. It is now the rule in the United States Courts, in England and in most of the states of the United States, that the contributory negligence of a carrier is not attributable to a passenger. But in some of the states, the doctrine that it is imputable, and will bar a recovery has been established. Yet it would seem that the recent repudiation of the doctrine of *Thorogood vs. Bryan* by the Supreme Court of the United States, and the distinct manner in which that case has now been overruled in England, indicate an entire abandonment of the doctrine that the contributory negligence of a carrier should be imputed to a passenger. 5 American and English Encyclopædia of Law 82 et seq.)

From a footnote to same, the following is taken:—"In *Thorogood vs. Bryan* 8 C. B. 115, it was held that a passenger in an omnibus, injured by the negligence of the driver of another omnibus, had no action against the latter, because the driver of the omnibus carrying the passenger, by his negligence, contributed to the injury. In *Bennett vs. New Jersey R. Co.*, 36 N. J. L. 225, it was held that the driver of a horse car was not the agent of the passenger so as to render the passenger chargeable for the driver's negligence. In speaking of the 'identification' of a passenger in the omnibus with the driver, mentioned in *Thorogood vs. Bryan*, the Court said: "Such identification could result only in one way, that is, by considering such driver the servant of the passenger. To hold that the conductor of a street car or a railroad train is the agent of the numerous passengers who may chance to be in it, would be a pure fiction. It is obvious, in a suit against the proprietor of the car in which he was a passenger, there would be no recovery if the driver or conductor of such car is to be regarded as the servant of the passenger. And so, on the same ground, each passenger would be liable to every person injured by the carelessness of such driver or conductor, because, if the negligence of such agent is to be attributed to the passenger for one purpose, it would be entirely arbitrary to say that he is not to be affected by it for other purposes.")

*Injury to Child—Care Required of Motorman—Question for Jury.*

A boy less than five years old, on seeing an electric train coming along the street, ran from the side-walk with extended arms. The motorman saw him, and shouted and motioned to him to go back. The child, however, continued to run, and, catching hold of the side

netting of the rear car, was thrown down and injured. *Held*, that the question whether the motor-man should have stopped the cars, in view of the tender age of the child and his apparent intention to lay hold of the car, should have been submitted to the jury.

(Supreme Court of Minnesota. *Mason vs. Minneapolis St. R. Co.* 55 Northwestern Reporter 1122.)

*Rebuilding Street Railway—Municipal Control of Streets.*

Under the charter of the city of Trenton, giving the city council authority to prescribe the manner in which corporations shall exercise any privilege granted them in the use of any street, or in the digging up of same, a street railway company may be enjoined from rebuilding its road without the consent of the Board of Public Works of the city, which has succeeded to the powers of the council.

(New Jersey Court of Chancery. *City of Trenton vs. Trenton Passenger R. Co.* 27 Atlantic Reporter 483.)

*City Ordinances—Contracts—Interference with Franchise Granted—Jurisdiction of Federal Court.*

City ordinances made in pursuance of law and granting to a corporation the right to build and operate street railway lines in the city, after acceptance by the corporation and expenditure of large sums of money on the faith thereof, constitute a contract protected by the Constitution of the United States forbidding states to make any law impairing the obligation of contracts.

Act of Indiana, March 6, 1891, conferred upon the city of Indianapolis the power by contract, when approved by ordinance of its common council, to grant franchises to street car companies. *Held*, that the exercise of this power by the Board of Public Works with the approval, by ordinance, of the common council, was a law of the state within the meaning of the Federal Constitution.

A Federal Court has jurisdiction of a bill in equity alleging that complainant has a valid contract with a city conferring upon complainant the privilege of laying tracks and operating street railway lines on all the streets of the city, and that the contract provides that the city shall not confer upon any person or corporation any privilege which will conflict with the rights granted to complainant; and alleging further that the city has granted the right to lay tracks and to operate street railroads on certain streets, to respondent, and that respondent cannot do so without interfering with and substantially destroying the complainant's lines, and impairing the privileges before granted to complainant.

(United States Circuit Court, District of Indiana. *Citizens Street R. Co. vs. City R. Co.* 56 Federal Reporter 746.)

*Railway in Street—Invalid Ordinance—Expiration of Legal Existence of Company.*

The city of Detroit passed an invalid ordinance to extend the right of a corporation to own and operate a street railway beyond the time to which the life of the corporation was by law limited. The grantee assigned

all its property and franchises to a second corporation. Thereafter an ordinance was passed fixing the time beyond which the tracks should not remain in the streets at the time at which the life of the grantee corporation would expire. *Held*, that the continuance of the tracks in the streets after that day was a public nuisance which a Court of Equity would abate.

The fact that such extension ordinance was accepted and quietly acquiesced in by both parties for ten years during the term of the original grant, and that the corporation expended large sums of money on the faith thereof, does not estop the city from denying the validity of the extension after the expiration of the original grant, as against the grantee corporation, although it might be estopped as against the assignee thereof by its dealings directly with such assignee, if such assignee was a corporation whose life extended beyond the period of the extending grant.

(United States Circuit Court, District of Michigan, *City of Detroit vs. Detroit City Railway Company.* 56 Federal Reporter 867.)

*Connecting Lines—Coupon Tickets—Fragment of Coupon—Refusal of Conductor to Accept.*

A ticket for a continuous ride over the whole length of a street railway and a connecting line, was of a peculiar color and print and was composed of two coupons, the upper of which was for use on the connecting line and gave the names of its termini below and the names of both lines above. *Held*, that a conductor of the connecting line was bound to accept for passage an upper fragment of the upper coupon which gave the names of the lines, on the assumption that the conductor of the other line carelessly tore off the part giving the termini in taking the lower coupon.

(Supreme Court of Michigan. *Rouser vs. North Park Street Railway Company,* 56 Northwestern Reporter 937.)

*Negligence—Car Obstructing Cross Street—Injury to Vehicle.*

In an action against a street railway company for damage to plaintiff's carriage, it appeared that plaintiff, an undertaker, occupied his carriage in front of a funeral procession; that he arrived at a street crossing about the time that defendant's car reached said crossing; that the car suddenly stopped directly across the street on which the procession was moving, and compelled plaintiff to stop suddenly within five feet of the car; that all the carriages in the rear were thus caused to stop suddenly; and that the pole of the first of such carriages came in contact with plaintiff's carriage, breaking in the panels. *Held*, that the stopping of the car was the proximate cause of the damage to plaintiff's carriage.

Defendant's negligence was sufficiently proved by it conceding that it obstructed the street in violation of a penal ordinance of the city.

(Supreme Court of Wisconsin, *Mueller vs. Milwaukee Street Railway Company.* 56 Northwestern Reporter 914.)

## MARSEILLES ELECTRIC RAILWAY.

Down on the coast of the Mediterranean, under the blue sky of southern France, in fact in the historic old town of Marseilles, celebrated in song and story, a new invigorating element has been introduced. It is needless to say that it is an electric railway.

Marseilles has long had the most extensive street railway system in France. Its streets are crooked, narrow, crowded and full of steep grades, all very harrowing to the French horses, and costly to the French pocket-book. The street pavement is mainly of hard and slippery por-

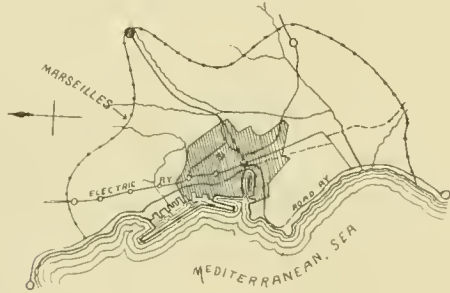

phyritic granite. The whole system comprises some forty miles of track, all double, owned and operated by the Compagnie Generale Francaise, which also owns the concessions of Tours, Orleans, Nancy and Genoa, (Italy). The Marseilles concession was granted for fifty years with right of purchase at the then valuation at expiration of the time. The older lines are worked by horses, the cost of which is 12.3 cents per mile. This in proportion to other cities\* is very high.

In Lyons horse traction cost.....	10.7 cents per car mile
" Bordeaux " " " .....	9.8 " " " "
" Toulouse " " " .....	9.2 " " " "
" Genoa, Italy, horse traction cost.....	8.86 " " " "
" Turin, " " " " .....	8.26 " " " "
" Milan, " " " " .....	4.64 " " " "
" Florence, Italy, " " " .....	7.62 " " " "

\*These figures are by Dr. Preller.

Under the circumstances the company tried various systems of mechanical traction, including Rowan's steam cars, Mekarski's compressed air and dummies of various patterns. The steam appliances were too costly and the compressed air system was unmanageable.

To the popular locality of St. Louis the Compagnie Generale has adopted the overhead electric system, which it is the purpose of this article to detail. Sautter, Harle & Co., of Paris, and the Oerlikon Works, of Zurich, were contractors for construction and equipment. The contractors, it is said, guaranteed that the cost of traction should not exceed 6.72 cents per car mile. This limit was afterwards raised to 8.56 cents.

The line is about four miles in length, covering the territory indicated in the subjoined map, and is double tracked throughout. It starts at the grand boulevard, the Cannebiere, and runs up the narrow rue d'Aix with grades of 5 and 6 per cent: through the manufacturing suburb of St. Lazare with gradients of 2 to 4 per cent, then through other suburbs to St. Louis, with grades of

3 to 5 per cent, thus having no single level section throughout the entire length. There are three regular stations on the route, but passengers may be picked up or set down anywhere on the line. The center of the roadway is used for road bed, except at terminals and fixed stations. The route follows streets ranging from thirty-three to forty feet in width, but the rue d'Aix is only twenty-three feet wide.

The road bed is mainly of granite pavement, laid with 54-pound girder rail. The rails are supported on steel chairs bolted to steel ties. The sleepers weigh 37.4 pounds each, or 64 pounds with chairs, and are 5.5 feet long. The additional fish plates, which are unusually heavy, make the entire weight of the steel road bed 170 pounds per lineal yard. The ties are spaced 3.28 feet apart and 1.64 feet at joints, which are broken.

The steel construction affords good return and in addition a copper bond is used, besides a return wire, which strangely enough, is a lead-covered galvanized iron wire.

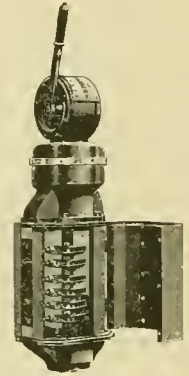

OERLIKON CONTROLLER.

The principal disturbing element in European electric railway troubles is the telephone circuit. This in Marseilles was particularly aggravated by an ancient system that damp weather alone often disarranged completely, or a proximity of often two or three feet of the telephone wire to the railway feeder. The trouble was finally settled by the installing of a metallic return for the telephone by the railway company, at an expense of \$15,000.

The power station is about midway between the termini and forms part of the great "Lazaret" depot. This depot, erected in 1891, covers 9,560 square yards and comprises a three-story office building, dwelling houses

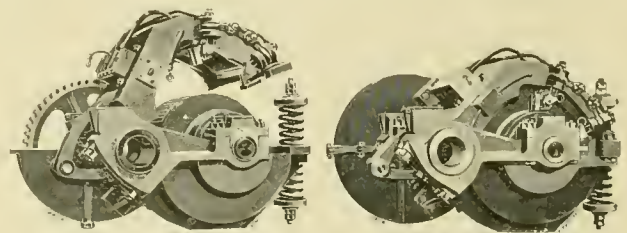

OERLIKON MOTOR.

for the force, storage barns, machine shops, water tanks holding 200 tons, coal shed for 1,000 tons, and stabling for 200 horses. An original installation of 300-horsepower for the line proved inadequate and the plant was remodelled to 500-horsepower. Three horizontal single-acting condensing engines are in use; the larger, 22 by 48 and the two smaller 16 by 42, developing 300-horsepower and 125-horsepower respectively. These engines are guaranteed to work with a steam consumption of not exceeding 20 pounds per horse-power per hour, from full to no load, with 180 pounds boiler press-

ure. They are also guaranteed not to vary in speed more than two revolutions from full to quarter load within two minutes. They are built by Van der Kerchove's works at Ghent.

Three 100-horse-power bi-polar direct-driven generators of the original plant were replaced by belt driven four-pole Oerlikon dynamos, whose drum armatures are wound in grooves with cross connections in the commutators. The double winding is inserted in mica sheet insulation, fitted in slots of the armature core. The commutators are of hard laminated copper. The two large dynamos give 280-horse-power at 300 revolutions, while the smaller machine at 350 revolutions gives 140-horse-power.

The overhead construction is similar to American practice. Number 3 silicon bronze trolley wire, is strung 16 to 18 feet above the rail, using compressed and paraffined wood insulators. Center-pole construction is usual in suburbs, with suspension from the walls of

made are in the commutator. The small pinion is of aluminium bronze and the larger of mild steel. Vertical spring suspension holds the motor to car frame. The controller is different in form from American practice, but essentially the same, with six contacts.

The brakes are ordinary hand-chain brake and a track brake, or as it is called in England, a slipper brake. These are found sufficient for all purposes, including the letter of the law.

Taken all in all the Marseilles road is perhaps the most distinctively modern electric railway in France. We are indebted to London Engineering for our illustrations.

FRANCE is taking several forward steps in electric traction. The town of Dijon has given a concession for its electric tramways to a contractor, of Lyons. The municipality of Grasse has been asked for an electric railway franchise by M. Leveque. Mouveaux will have a trolley line on an American franchise basis.

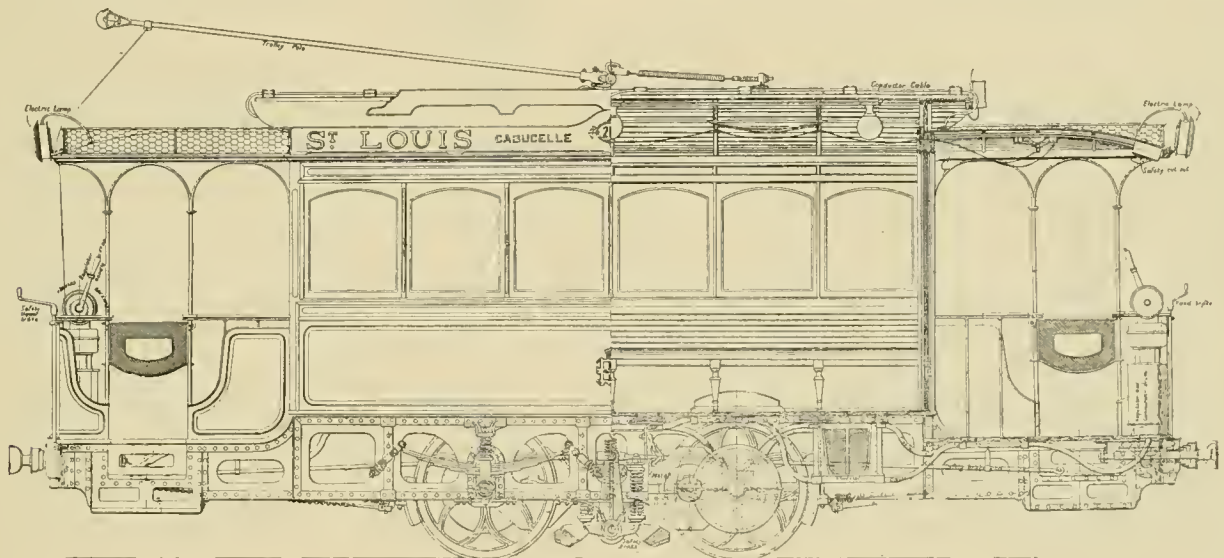

DETAIL OF MARSAILLES ELECTRIC CAR.

houses or from poles in town. The feeder system is divided into four independent sections.

Our drawing of the car in vogue, shows a four-wheeled rigid 5.9 foot wheel base car. The wheels are 39 inches diameter, and the car measures 30 feet over all. Perhaps a flexible wheel base and double truck will be introduced by some enterprising truck manufacturer. The car seats 20 people and has room for 15 on platforms, with no roof seats. The car weighs with motors 6.8; loaded 9 tons; with overload of 75 passengers, which is usual in spite of laws to the contrary, 12 tons. Lighted by five electric lamps inside and two reflectors outside.

The motors first used were bi-polar, 12-horse-power, worm geared one in fifteen pitch. These were soon replaced by Oerlikon motors, nominal 18-horse-power, but capable of developing up to thirty, driving by horizontal spur gear. These Oerlikon motors (see illustration), are four-poled. The yoke with the pole cores, which also forms the casing is of mild steel with special compound winding inserted in slots. Cross connections

### SIoux CITY'S CONSOLIDATION.

After the recent panic in which the newer towns suffered the extremes, the surface railways of Sioux City were left in bad financial condition. This resulted in the organization of the Sioux City Consolidated Street Railway Company, by John Pierce, A. E. Pierce, Peter and Chris Moller and H. A. Johns, absorbing the Sioux City Cable; the Sioux City Street Railway, electric; Rapid Transit Railway; Riverside Electric; Sioux City & Leeds Electric. The company is capitalized at \$1,000,000, with offices in New York and Sioux City. The incorporators deeded \$1,200,000 in realty to the company. It is on a firm basis.

P. H. HOVER, formerly of the Standard Paint Company as Chicago representative, has severed his connection with that concern to assume a position with the Mica Roofing Company, of New York. Mr. Hover will attend to the same branch of the trade as formerly, his new connection operating in similar lines.

## ENGLISH ROADS WANT ELECTRICITY.

Our bright contemporary, Lightning, says that the following session of parliament will be asked for a dozen mechanical traction concessions, as follows:

NAMES OF APPLICANTS.	POWERS ASKED.
Abergele and Pensarn Pier Company (Limited)	Construction of tramway. Use of electricity or other motive power.
Barrow-in-Furness Corporation	Construction of tramways. Use of electricity or other motive power.
Bristol Tramways and Carriage Company (Limited)	Construction of tramways. Use of electricity or other motive power.
Central London Railway Company to be formed	Extension of line. Construction of railway (partly underground) from South Place, Finsbury, to Walthamstow and Epping Forest Use of electricity and steam or other motive power.
Croydon Corporation.	Construction of tramways. Use of electricity or other motive power.
Croydon Tramways Company	Construction of tramways in Croydon and Streatham. Use of electricity or other motive power (except steam).
Dudley and Wolverhampton Tramways (Limited)	Construction of tramways in Dudley and Wolverhampton, and from Wolverhampton to Bilston. Use of electricity or other motive power.
Hull Street Tramways Company	Power to transfer part of undertaking. Use of electricity or other motive power.
Liverpool Corporation	Construction of tramways. Use of electricity or other motive power.
Liverpool United Tramways and Omnibus Company	Construction of tramways in Bootle and Walton-on-the-Hill. Use of electricity or other motive power.
South Staffordshire Tramways Company	Construction of tramways in West Bromwich and Handsworth. Use of electricity or other motive power.
West London Tramways Company (Limited)	Construction of tramways in Acton, Hammersmith, and Fulham. Use of mechanical power.

All of this shows that the British public is about to awake to the necessities of the occasion. The subject of electric traction is being pushed more vigorously and practically by Lightning than by any other of the English electrical publications.

## PERFORMANCE OF A TRIPLE EXPANSION ENGINE.

Owing to the increasing interest that is being taken in multi-cylinder engines for use in large plants, we reproduce here some indicator diagrams from the triple expansion vertical McIntosh & Seymour engine, in the Elmira Illuminating Company's plant. This engine has four cylinders (two low pressure) of the dimensions shown on the cards. It is rated at 500-horse-power and is used to carry the load of lights during the heavy load hours, from dusk till midnight only. The heavy load cards were taken at six o'clock on an ordinary night, and the minimum load cards on Sunday evening, when the load was lightest. These are the two extremes of station load and the showing is a remarkably good one in both cases. The engine has a speed drop of only three revolutions from full to no load condensing. It is certainly an all around record to be proud of. The month of November, this year, gave a saving of 61 per cent in the new station

over the old one during November, 1892, or a saving of 61 per cent due to the use of well loaded triple expansion

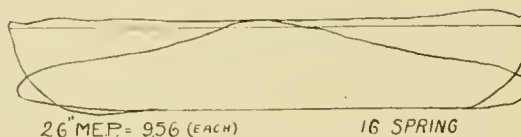
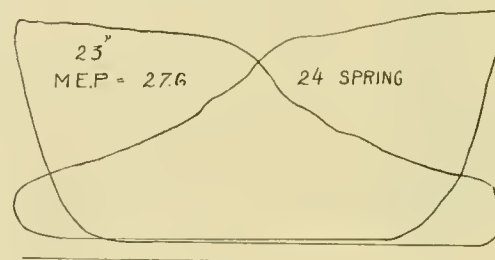
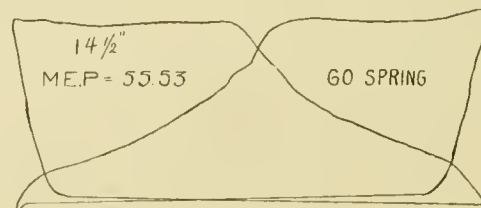

FIG. 1—MAXIMUM STATION LOAD.  
Initial pressure, 139. Revolutions, 139. Horse-power, 518.69.

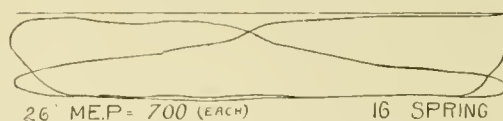
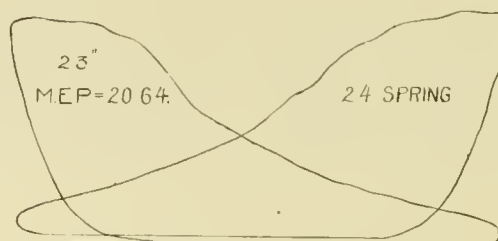
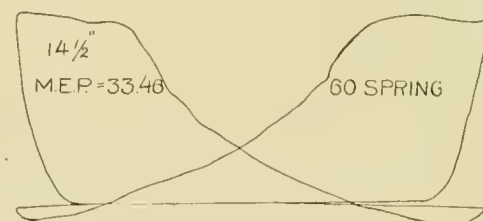

FIG. 2.—MINIMUM STATION LOAD.  
Initial pressure, 137. Revolutions, 140. Horse-power, 374.62.

engines. The vertical engine works so well that the engineers want to run it all the time. The indicator cards as reproduced are three-fourths actual size.



### THE "CROWN" GLASS OIL CUP.

The accompanying engraving represents Lunkenheimer's "Crown" index sight feed glass oil cup. It is provided with an "index" for regulating the oil flow, and an indicator arm turning on the lid to mark the notch giving the desired feed. When the feed is shut off, the lever can be left standing up out of the notch, so that it can be seen from a distance that the feed is off. When there are a number of oil cups to be looked after it is almost impossible that they all should need the same feed, and it is just as impossible to remember how much each individual one requires. The use of the index for showing the proper feed relieves this difficulty, and also makes it possible to temporarily increase the feed without losing the adjustment for the ordinary run. Besides the "Crown," this company makes seven other styles for various purposes. These cups are made by the Lunkenheimer Company, of Cincinnati, and the high standard of the specialties made by them insures the "Crown" as a trustworthy appliance.



CROWN OIL CUP.

### A CAR BADGE.

That conductors and drivers should wear a badge is a conceded advantage, but not in many cities must the car itself be similarly decorated.

The time honored custom at Savannah, Ga., and the city fathers, decree that no street car shall leave its barn



without a regulation badge, a fac-simile of which is shown herewith. This evidence of municipal regard is secured by the railway company on the payment, in advance, on the first day of every year, of thirty dollars for each badge. A recent interpretation of the ordinance was that a badge must be taken out for each car owned

by the company, whether in service or not. Last year the road paid \$270 for badges, in addition to usual state, city and county taxes. This year their badges will cost over \$600 for cars in actual service, but over \$1,500 if paid on all cars owned.

There is quite a question in many states as to the legal right of cities to impose what is generally known as the car license, and which is usually exacted under the excuse of being a police measure. There certainly is no justice in taxing cars not on the street, for they have already been heavily taxed as personal property. The method which has prevailed in Chicago for many years seems a much more equitable one, and is based on the number of trips actually run, regardless of how many cars the companies may own. The amount is placed at fifty dollars per car per year, payable in four quarterly installments. The number of cars on which any quarter's payment is to be made, is determined by taking the entire number of trips, long or short, run on all of any road's lines during the three months. Dividing this sum by the number of days in the quarter, (usually 91, or 92) gives an average number of trips per day, which is again divided by thirteen, which number has been agreed upon as constituting a car day; the result of this division gives the average number of cars per day for the quarter on which the license of \$12.50 must be paid. A sworn statement by the secretary of the company as to the total number of trips accompanies the voucher and check. The amount so paid into the city treasury of Chicago, aggregates about \$45,000 per annum.

At Allentown, Pa., the question of an equitable license on summer and winter cars was recently given an opinion by City Solicitor Trexler, who held thus:

"In my opinion a license tax can only be collected from each car—that is from each construction that constitutes a car. To hold that a car or truck which in winter time is surmounted by a closed superstructure and in summer by an open body constitutes two cars is, I think, unreasonable. It is the wheels and running gear and motor which, in my opinion, constitute the car."

In other words the license is on cars in the street; those in the barn are already taxed, and taxed hard. There is as much justice and sense in imposing a license on a car not in use, as on a lot of buggies and wagons on sale or exhibition in a dealer's repository.

### FIFTY-THOUSAND DOLLARS FOR A PLAN.

The Metropolitan Traction Company, of New York City, has made public, and published offer of a bonus of \$50,000 to the inventor of a system of traction demonstrated superior or equal to the overhead trolley. The decision shall be left to the State Railroad Commission. No claim is made to the inventor's rights. The traction company will pay no trial expenses. The prize will be awarded March 1, 1894. The offer is made in a letter to the commission which endorses the cable for down town districts, heavy traffic and straight routes.

**SUPPLY DEPARTMENT OF THE MILWAUKEE STREET RAILWAY.**

The store room of the Milwaukee Street Railway is noted the world over for its completeness. The labor of the storekeeper is unusually severe, because of the great variety of apparatus in use on the road, which greatly increases the number of repair parts to be kept.

The following is the system of store keeping in use, and we believe it will be of interest to every large road.

material such as bolts, nails, screws, etc., which are classed under general headings for each line. From the "Stock Ledger" the amount and name of the materials are entered in the "Material Received Book," Blank B, under the firm name from whom purchased. The invoice is then pasted in the "Invoice Book."

Material is arranged in sections or departments as far as possible, as for example: bodies, trucks, trolleys, controllers, line tools. In placing each article in its section, facility in handling is secured by piling it in certain rows

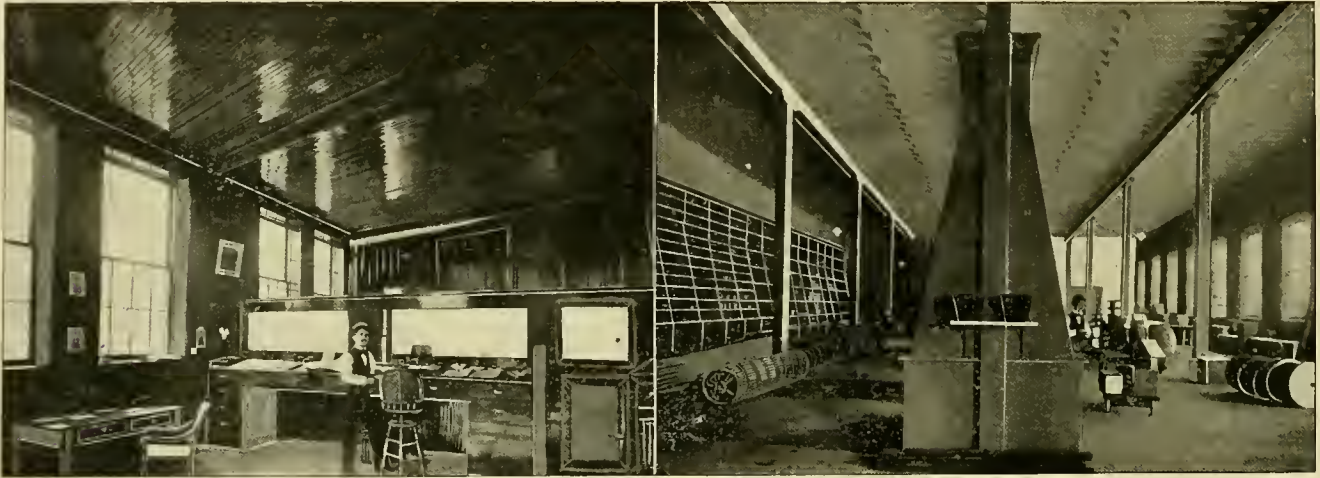

VIEWS IN STORE ROOM AND OFFICE.

On receiving supplies they are counted, weighed or measured, as the case may be, and notice of receipt sent to the purchasing department, on Blank A. The latter department forwards the original bill to the auditor and a duplicate to the storekeeper. Quality of material is

or piles, as carbon brushes in fifties and hundreds; tape in ten and twenty pound piles, etc. Gears and pinions are numbered with steel figures on being drawn out and the number entered in the "Ledger" with the charge, thus preserving a record of the same, making it possible to tell



WINDOW WHERE SUPPLIES ARE ISSUED.

determined by guages and measures, and in case of any doubt, notice is given to the superintendent to whose department the material belongs, to inspect the same. This occurs very seldom, as requisitions are required to be very exact in specification. The amount of an invoice is entered in the "Stock Ledger,"—each article having a separate account, indexed alphabetically, except lines of

the life of each gear or pinion. Car lights are crated in bins, holding six and twelve packages, with straw. Brake shoes are stored in racks, made of scantlings far enough apart to admit of three shoes deep and four wide, piled twenty high. The oils are stored in a fireproof room, one of each variety being tapped for the minor orders,

**MILWAUKEE STREET RAILWAY CO.**

(A)

MILWAUKEE,.....189....

*Purchasing Department:*

I have received this day the following goods, delivered at \_\_\_\_\_, in good order, with exceptions as noted.

QUANTITY.	MATERIAL.







THE PLACING OF CAR TRUCKS FOR ROUNDING CURVES.

BY EMIL EHNBOM.

During my work in constructing street cars of all kinds, for both urban and suburban use, I have found certain details in the designing to re-occur in every instance, and as they mostly belong to the preliminary work and often had to be answered in short order, I contrived to establish certain formulas for each occasion, which would answer for any case of the same character. By having these formulas handy I have been able to answer important questions in a few minutes that otherwise would have taken hours to "lay out" on the drawing table.

The first question that occurred was the "radiation" of the axles under a four-wheel car while turning a curve. When a car on four wheels turns a curve, the natural tendency of the axles is to radiate, that is, to appear in the elongation of the radius describing the curve (see Figure 1), and the distance between the outside wheels tends to be longer than the distance between the inside ones. Certain provisions may therefore be necessary in regard to boxes, pedestals, and their fastenings, or with the brass bearings of the boxes on account of the strain that is produced. The four wheels of a truck under a double truck car act just in the same way as the wheels under a four-wheel car. The following formula gives the ratio of radiation:

$$O - I = \frac{G \times W}{R} \quad \text{(See Figure 1.)}$$

Where O = Distance between centers of the outside wheels.

I = Distance between centers of inside wheels.

G = Gauge of track.

W = Wheel base.

R = Radius of the curve taken in the center of the track.

By examining the above formula it will be found that the difference between O and I or O-I decreases as either the gauge or the wheel-base decreases or as the radius increases in value. Hence the narrower the gauge and shorter the wheel-base or larger the curve, the less strain on the truck construction.

Example.—For a car with 6-foot wheel-base standard track and on a 50-foot curve.

$$O - I = \frac{4 \text{ feet } 8\frac{1}{2} \text{ inches} \times 6 \text{ feet.}}{50 \text{ feet}}$$

reduced to inches

$$O - I = \frac{56.5 \times 72}{600} = 6.78 \text{ inches.}$$

For a 40-foot curve  $O - I = 8\frac{1}{2}$ , and for a 30-foot curve  $O - I = 11\frac{5}{8}$  inches.

The first thing about a suburban or double-truck car is to lay out the "bottom" and to locate the intermediate or center sills, so as to avoid having the wheels cut, either them or the end sills, while the car is turning a curve.

The radius of the shortest curve the car has to run on is generally found by information from the railway company, and the wheel-base of the trucks is, as a rule, given. It is conceded that the longer the truck base or distance between centers of trucks the better it is.

The problem then is: first, to find the longest truck centers that will not make the wheels interfere with the end sills; second, that will permit the intermediate sills to be put far enough apart to give the "underneath" mech-

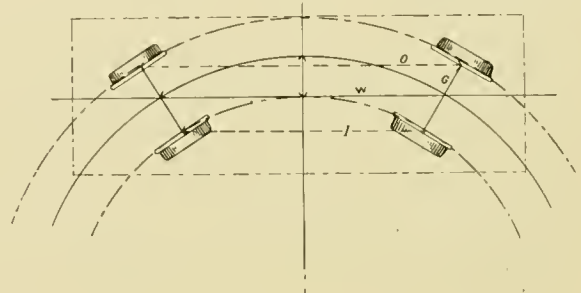

FIG. 1.

anism ample room while the car rounds a curve. If the position of the truck on the curve is found, the problem might be considered solved, and to find this position the curve or center between tracks must be laid down correctly relative to the car. The shortest and easiest way to do this is to lay off both the longitudinal center line *c c* and transverse *1 1* (see Figure 2), then draw end sills and side sills and assume the longest centers possible (which in this case are identical with the king bolts  $\kappa$ ), and then by solving the formulas given below, two points, *x* and *y* of the curve or center of track are found, when a sweep

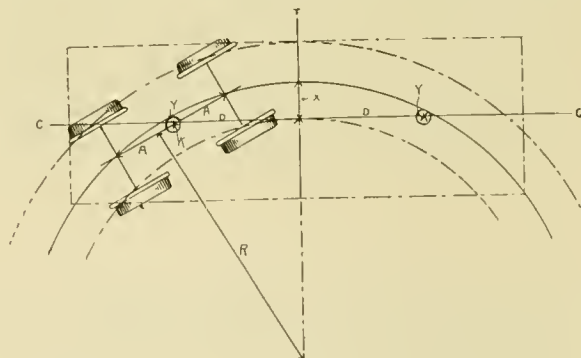

FIG. 2.

of the same radius as the curve (or proportional according to scale) can be used and the curvature be drawn correctly at once. The diagram Figure 2 explains better than words, and it is a much quicker and surer way than to bother with the trammel and finding a convenient rest for its center. In the formulas

A = half the wheel-base.

D = half the truck centers (or half distance between kingbolts.)

R = radius of curve taken in center of track.

X = the longest horizontal distance from the center of the track to the center line of the car body.

Y = the distance the kingbolt falls inside the center of track while going around a curve.

X and Y are to be found. A, D and R are given.

Then

$$X = R - \sqrt{R^2 - A^2 - D^2}$$

$$Y = R - \sqrt{R^2 - A^2}$$

For example.—Take a car body 30 feet on the corner posts and 7 feet on the side sills, and having a pair of trucks with 6-foot wheel-base and 30-inch wheels. The shortest curve has a radius of 30 feet. Then assume the truck centers to be 18 feet.

When:

$$X = 30 - \sqrt{30^2 - 3^2 - 9^2}$$

$$\text{or } X = 30 - 9 \sqrt{10}$$

reducing feet to inches

$$X = 360 - 108 \sqrt{10}$$

$$\text{or } X = 18.4716 \text{ inches,}$$

Also:

$$Y = 30 - \sqrt{30^2 - 3^2}$$

reducing to inches and solving

$$Y = 1.807 \text{ inch.}$$

This means that the center of the truck runs 18.47 inches from the center line c c and is tangent to a circle with 1.80 radius and the kingbolts for center. The curve is now correct, and if it is found that the kingbolts or truck centers are not spaced right they may readily be changed to suit.

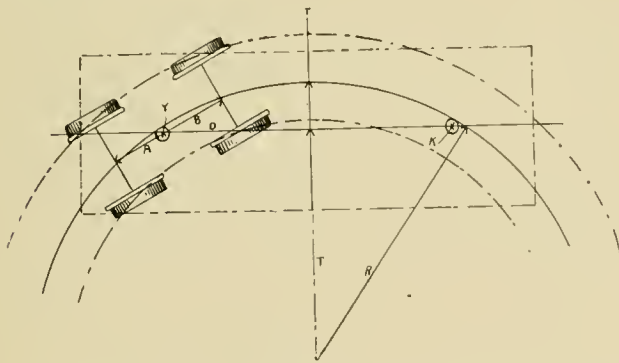

FIG. 3.

In case the truck centers do not coincide with the kingbolts as with "maximum traction" trucks, the formulas are slightly changed like this:

$$X = R - \sqrt{R^2 - A B - D^2}$$

$$Y = R - \sqrt{R^2 - A B}$$

Where

A = distance from the kingbolt to outside axle.

B = distance from the kingbolt to the center of the inside axle.

In case the kingbolt should be placed directly over one axle then

$$X = R - \sqrt{R^2 - D^2}$$

$$Y = 0$$

For very small curves and long wheel base the center of the tracks does not lie either in the kingbolt or in the center of the axles between flanges of the wheels, but the difference is so small in any possible case as to be of no account.

### STEEL RAILS.

In an address before the New England Roadmasters' Association, P. H. Dudley gave some interesting data in relation to the structure of steel rails, starting with the premise that the rails that flow least under the wheel pressure give the best service, and those that flow the most give the poorest service. The most serviceable have a fine structure and small mineral aggregate, and the reverse of the proposition is also true. Each different weight of section requires a difference in composition. The author's sections are tabled as follows:

Weight per yard.....	Lbs.		Lbs.	
	60, 65, 70	Per cent.	75, 80	100
Carbon.....	0.45 to 0.55		0.50 to 0.60	0.65 to 0.75
Manganese.....	0.80 to 1.00		0.80 to 1.00	0.80 to 1.00
Silicon.....	0.10 to 0.15		0.10 to 0.15	0.10 to 0.15
Phosphorus, } not to.....	0.06		0.06	0.06
Sulphur, } exceed .....	0.07		0.07	0.07

The ingredients in general have the following virtues: Carbon by itself, up to or over 1 per cent increases hardness and tensile strength and decreases elongation. Manganese takes up the oxide of iron (rust) formed in the bath of molten metal during the blow. Silicon makes the steel lie quiet in the moulds. It tends to make crystallization small. Sulphur and phosphorus are two very objectional impurities. Sulphur makes the steel liable to crack in rolling. The amount of these chemicals now allowed, ranges from 0.06 to 0.11 of 1 per cent.

### A HAUNTED CAR.

The haunted house has no place in ghost lore. Even W. T. Stead, of London, can't keep up haunted houses. Haunted street cars are at present the proper haunt.

In Savannah, Ga., car 26 is haunted. Every time it goes past Laurel Grove Cemetery a voice of a child can be heard crying. It isn't the curve, because it began suddenly, and other cars are unaffected, and the motor and gears being properly inspected seem not at fault. Then besides, the car makes no sound when at a distance from the cemetery.

The sound is that of a child crying in pain. It seems to come from first the top and then beneath the car. It is more human than any squeak of the machinery can possibly be, and a constant fear possesses the employes that a real accident may happen on account of the supernatural sounds from the haunted car. History relates that a fatal accident did happen under the wheels of "26."

THE Buffalo, N. Y., kicker has divided himself, some wanting heated cars and others as strenuously desiring the cold variety.

## BRICK PAVING TO T RAIL.

The question as to whether it is practicable to pave to the T rail, has apparently ceased to be a question in many towns, especially in Illinois and Iowa. Where brick paving is coming extensively into use, the T rail is almost sure to come also, and in places where it is used the question seems never to be raised as to whether paving to them is a success or not. It seems to be taken as a matter of course. Among the many places that sanction the use of T rail are Bloomington, Ill., Decatur, Ill., Ft. Wayne, Ind., Champaign, Ill., Springfield, Mass., Ottumwa, Iowa, Des Moines, Iowa, Terre Haute, Ind., Atlanta, Ga., Windsor, Ont., Roanoke, Va., and Denver, Col. In some of these places the road is principally

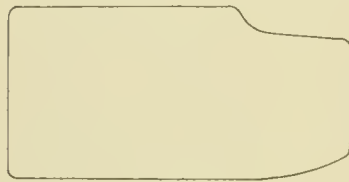

FIG. 1.

girder rail, and the city has changed its rules to allow the laying of T rail in the future. Where it has been laid there is no smooth iron tram for vehicles, and consequently there is not so much tendency to drive on or near the tracks, and the wear on the company's pavement is correspondingly light. Teamsters, city officers and transfer companies claim that as far as the street traffic goes, it is a less obstruction than the girder or tram rail, and a few minutes observation of the vehicle traffic on such streets bears out this statement. The main objection to the T rail for street tracks is that the groove between the rail and paving sometimes fills up with dust and ice so as to greatly hinder the car traffic, but by the use of sweepers in summer and salt in winter this is to a great extent prevented. The commonest form of brick for paving to T rail is shown in Figure 1.

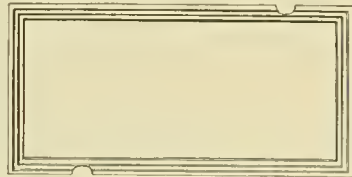

FIG. 2.

In some places however, the ordinary bricks are used and the workmen chip out pieces to make the groove for the flange and accommodate the head and base of the rail. The greater part of the brick paving in use at present is on a foundation of soft brick laid flatwise. If no chairs are used, and the rail is four inches high, the space between the ties is filled in with foundation bricks laid even with the top of the ties, and the paving bricks laid directly on these. In this case it is necessary to tamp very hard where the foundation bricks are laid between the ties, as the ties make an absolutely rigid foundation, and the paving between the ties is liable to settle. At Decatur, Ill., a cast iron block (Fig. 2) is used. It is the design of Superintendent Ferguson, and is simply a cast iron slab, flat on the bottom and paneled or hollowed on top to save iron. It is of course, laid with its longest dimension at right angles to the rail and the notches are for the spike holes. This raises the rail about three-quarters of an inch from the tie,

and gives room for a layer of sand between the foundation of brick and ties and the paving brick proper. The secret of the success of brick paving for use with T rail, is the fact that it furnishes a smooth surface with close joints, and the bricks can be moulded or clipped to any shape so as to make a good fit, not only with the main part of the rail, but at the joints and fishplates. A great many companies are in the habit of making their own T rail curves, the guard rail being made of a lighter section of T rail placed on blocks or chairs. This is claimed to be a cheap and durable construction, as the curves will wear as long as the head of the guard rail will last, which is of course, a good while. In many instances the guard rail is put only on the inside. When the paving is down, these rails have the appearance of being one piece with the track rail.

## HOLBERT SAND BOX.

The accompanying engravings will give a good idea of this sand box, which is the invention of C. E. Holbert. St. Joseph, Mo. It is claimed that it will pulverize almost anything short of solid rock,—wet sand, soft coal and

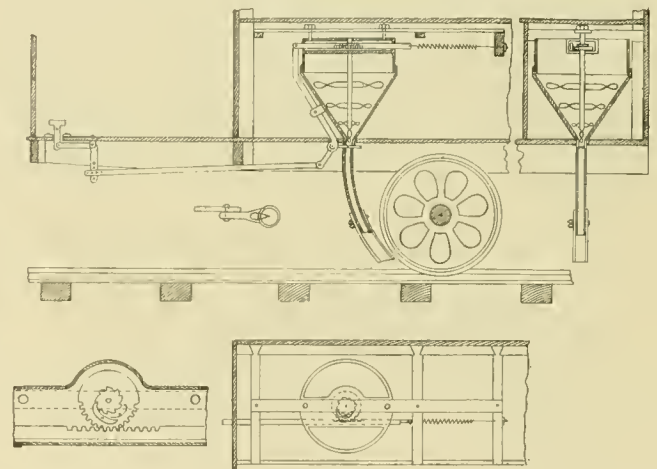

HOLBERT SAND BOX.

building brick proving easy prey for it. The spiral motion given by the fan shaped blades and auger shaped shaft is very persuasive in making the sand come down, no matter what shape it is in. Motion is given to this shaft by a treadle operated with ratchet and recoil spring, as a glance at the drawings will show.

## ROPE DRIVING.

William Kenyon, the English authority on rope driving, says in an article in *Lightning*, that the velocity of ropes on a rope drive should be between 3,000 and 4,600 feet per minute, though good results can be obtained with higher velocity. Horse-power can be calculated on a basis of 10-horse-power for 1,000 feet of speed with  $1\frac{3}{4}$ -inch diameter rope, and 5-horse-power for  $1\frac{1}{4}$ -inch rope.

THE Unicycle Street Railway Company, of St. Louis, is pushing forward its one-wheeled scheme.



## REMINISCENCES OF MR. RICHARDSON.

The one man that was known to every man, woman and child of the City of Churches was President William Richardson, a biography of whom is given on another page.

Mr. Richardson's varied career has been previously outlined. He was always at the front of every new movement.

In 1850 he was a Prohibitionist in politics, when prohibition was very unpopular, and was awarded the uncomfortable eminence of First Grand Worthy Associate of the Grand Division of New York. Later he was an active agitator of the "Free Soil" and "Anti-Nebraska" movements.

He was a member of the first Republican State Committee of New York and kept his allegiance to the end.

Thurlow Weed was his political sponsor, and asked him one day what he expected to do for a living when he resigned from the army. Mr. Richardson was at this time additional paymaster at New Orleans. "Anything," he replied, "anything honest—except office-holding."

In 1861 he was associate editor of the Albany Evening Journal, which line of work was familiar to him, having twice before been thus engaged.

Mr. Richardson went to Brooklyn in 1867, having forsworn politics for the nonce. He was comparatively a poor man. When he died he left a fortune estimated at \$5,000,000, all made in the street railway operations which have made him famous as a financier.

His fatal illness was an attack of grip, followed by a severe cold that developed into pneumonia, and the disease ran a quick course. He was attended by the best physicians of Brooklyn, notably his son, Dr. J. E. Richardson.

As a member of the Aldermanic Board of Brooklyn in 1870, and as an unsuccessful candidate for state senatorship, his political career closed.

Mr. Richardson was a Mason, an Odd-fellow, a member of the Masonic Veterans' Association and many civic societies, besides a Baptist of many years' standing.

## THE TROLLEY ON THE CANAL.

The report of the state engineer on the electrical propulsion of canal boats and the experiments made on the Rochester-Brighton division of the Erie canal, is not an unqualified commendation of this application of this transmission of power. After explaining that storage batteries are unavailable, and that, mechanically, there is no doubt of the feasibility of the methods, the engineer says: The main question is a purely economic one, and the proposition is, "can the electric power be furnished to each propeller at less cost than that of steam power." If the water-power of Niagara be utilized, the engineer says that method will be the cheapest. If power-houses are to be built, as in railway practice generally, "it might be possible, with the conditions obtaining on the canal, by using the best and most modern machinery, to obtain one indicated horse-power per hour for two pounds of coal,

but we can surely not hope to get below this limit. It is found that in passing the power from the steam chest to the dynamo, 8 per cent is lost; in passing through the dynamo and into the wire at the power-house, 10 per cent; in transmitting current a distance of eight miles, 15 per cent; and in passing it through motors to point of application on axle, 30 to 40 per cent; so that if canal experience should be similar to that of railway, if we succeed in developing in the engine cylinder one horse-power per hour with two pounds of coal, we would have a consumption of coal, to obtain one horse-power per hour, applied at a distance of eight miles from power-house, of from four and one-half to four and three-fourths pounds."

To just what degree the practices on water and on the railway, will resemble each other, and how "similar" they may be, is still a question to be decided by practice. The easier start, the smoother course, and the constant journey of the canal boat, will seem to the observer to be all in favor of economy, to say nothing of the ingenuity of our electrical inventors, who will find another outlet and will bring to the surface any number of smoldering ideas on motors especially adapted to canal traction.

The figures quoted by the engineer, are fair, with the exception of the last, which range from 5 to 8 per cent too high for a conservative estimate.

In concluding the report, he says:

"I recommend this subject to the legislature's careful consideration, and hope that, in view of the fact that the advantages to be gained by the successful solution of the problems involved are so manifest, you will adopt the necessary legislation to assure the continuance of the investigations and experiments required to reach a conclusion."

Superintendent Hannan of the State Department of Public Works, says in regard to canal propulsion, that last year, operation and repairs cost \$726,036. He thinks that by using the power-house system 210 days in the year for canal propulsion and the remainder of the year for factory power, that electricity will cost not over 5 cents per boat per mile. If factory power cannot be supplied, the cost will be doubled. "It will be therefore seen," says the report, "that the claims of electricity for this method of propulsion are extremely well founded."

## THAT OLD, OLD JOKE.

It was wild midnight. The lightning's flash, thunder's roar and dashing rain, mingled with the buzz of the trolley, as the electric car dashed madly along.

The solitary passenger approached the conductor. "Aren't you afraid of the lightning on these electric cars?"

The conductor's eyes glittered with a baleful light. "No," he answered; "lightning never strikes a good conductor, you know." The stranger reeled, fell over the railing and was speedily crunched under the car following close behind.

"One more," hissed the conductor, as with fiendish glee he bit a fresh nick in the brake handle.—Life.

### CABLE ACCIDENTS IN GREAT BRITAIN.

During a recent enquiry before that powerful organ, the British Board of Trade, David McGill, the general manager of the London Tramways Company, gave the following statistics on cable accidents as against horse car catastrophes. In the first six months of the former the number of accidents was 6.23 per car as against 4.21 occurring with horse power, while in the second six months the proportion of accidents was 1.75 cable and 4.75 horse power. The use of cable power was governed by strict regulations among the employes. There had only been one cable replaced since the instalment of the system, and that was in July, when horse power was resorted to during replacement. The reference made is for a time between July 1 and December 10.

WHILE the inhabitants of 135th street, New York, slept, the Union Railway Company laid a double track along that classic thoroughfare of Harlem, Christmas Day, and the day preceding being Sunday, gave a good space of 48 hours in which to do the work, in consequence of which the Huckleberry Railway is in and the enjoiners are out. The fortunate junction of Sunday and New Year's Day made the stringing of wires possible.

### FIREPROOF BUILDINGS ON THE NEW ORLEANS & CARROLLTON.

The accompanying illustrations are of the fireproof car shed and power house, designed and built by the Berlin Iron Bridge Company, of East Berlin, Conn. It adds another notable piece of electric power station and car

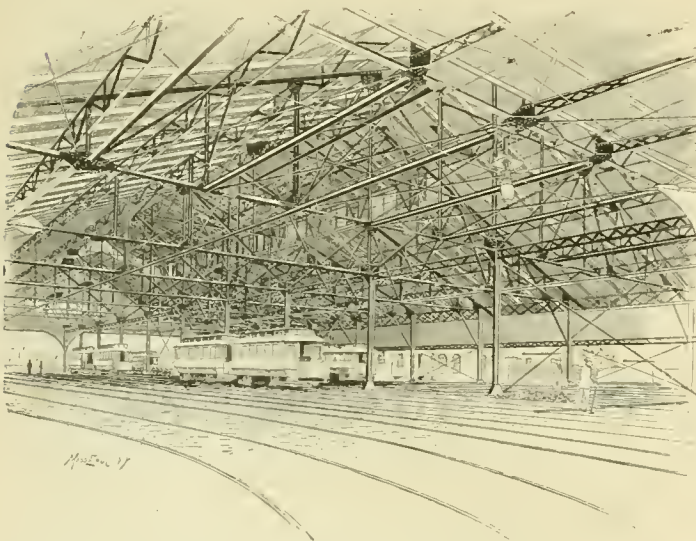

CARROLLTON CAR SHED, NEW ORLEANS.

barn work to the great number already constructed by that company. The car shed is 126 feet in width and 300 feet in length. Light is secured through the side windows of the monitor. The sides of the building for a distance of ten feet from the ground are left entirely open. A building can be constructed this way in the south,

because the climate never necessitates a closed structure. The power house is similar in construction to the car shed, except that the side walls are brick. The particular feature, however, of this part of the plant, is the portable crane, shown in the foreground. This crane is so arranged that it can be easily moved to any part of the building, and is of sufficient capacity to raise and lower the machinery in and out of place. In the case of this

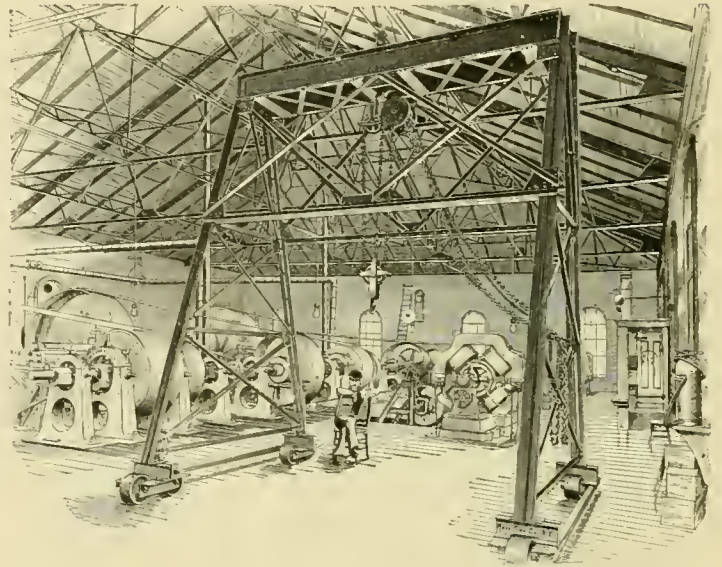

N. O. & C. POWER STATION, NEW ORLEANS.

power house, a traveling crane of the full width of the building would be an expensive matter, and owing to the general arrangement of the steam pipes and belts this construction would be inexpedient and inadvisable. To meet this necessity the crane illustrated and shown in the above illustration was designed and built by the Berlin Company, and has proved a great success. The construction of both buildings is a credit to the builders, as well as to the New Orleans & Carrollton Railroad Company.

### HOW THEY WILL DO IT IN STREATOR.

"Mr. W. H. Greener," says the Streator Times, "has invented and patented a scheme to run street cars by water power, without the use of steam or electricity. The water is in a tank on the top of the car, and operates on the principle of a water motor. The machinery is beneath the car. When it has served its purpose for propelling the car, the momentum of the car forces it back to the tank and saves the liquid."

Oh, Mr. Greener, Mr. Greener! Thou oughtest to sell thy patent right to a large syndicate, and out-Keeley-Keeley.

A NEW company, capitalized at \$40,000, has been organized at London, to construct tramways and operate same in Spain or elsewhere. G. St. John Mildmay, Broad street avenue, Blomfield street, London, E. C., is the principal, with H. V. Rudston Head, W. C. Tyndale, L. Earl et al., as associates.

A TOWER AND TOOL CAR.

The latest device for the lineman's comfort is a combined tower and tool car. The one of which the plans are here presented, was built by Thomas Winn, of Altoona, Pa., for the City Passenger Railway, of that city. The car has a 14-foot body, and is seven feet wide. It will be seen that there are two platforms, one on the car deck and the other above, on which the lineman works. The top platform is fifteen feet from the track. The nominal height of the trolley line is twenty feet. To make it, an old horse car was taken and the hood cut off one end. The frame for the tower is

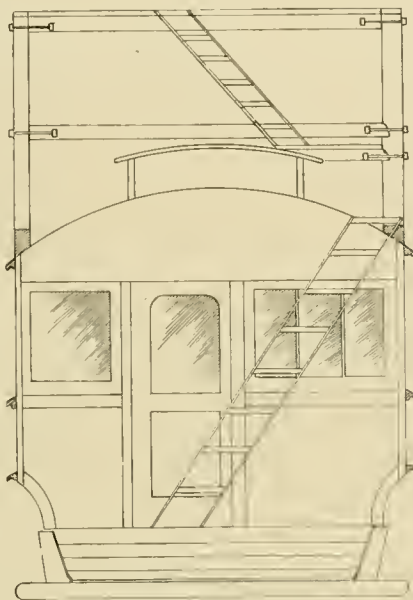

END VIEW OF TOWER CAR.

3 by 3 inch ash, fastened with wood screws 3½ inches long. On the lower deck large tools are kept.

The middle of the lineman's platform on top is made sliding, it being possible to run it out four or five feet on either side with safety. There are also drop rails on this

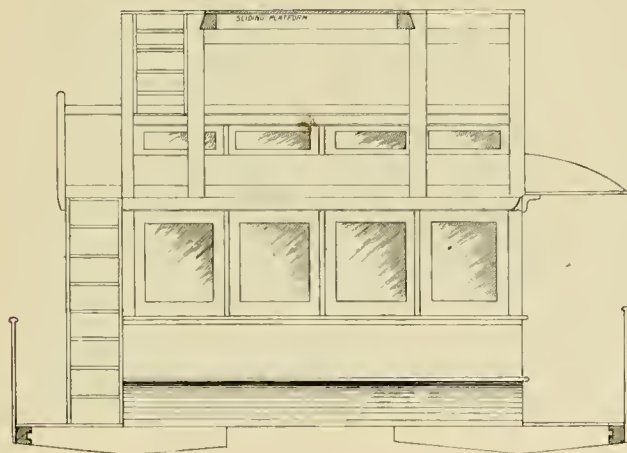

SIDE VIEW OF TOWER CAR.

platform, not shown in the illustrations. They are lowered when the car is taken into the barn. The sliding platform makes it possible to reach the poles, so that a ladder is unnecessary for line work. Inside, the car has a full supply of line tools and material, a work bench, and stove. In fact, it is a regular traveling shop. The lineman has simply to go "downstairs" to find anything he needs. It is not to be wondered at that the boys on the line at Altoona appreciate this car.

EXPERIENCES OF A SUPERINTENDENT.

By C. P. Young, Superintendent Chattanooga Electric Railway.

PART II.

The ideal superintendent of an electric railroad should possess the following qualifications, which are essential to his success. He must be an expert machinist and mechanical engineer, an expert electrician, a first-class street railroad man, a good track and lineman, must be a good judge of human nature and manager of men, must possess an inexhaustible memory, must be amiable yet firm and strong of character, understand making his word law, and stand like the captain of the ship. Everyone looks to him for advice and information in case of trouble and difficulty. Such a man should be given full freedom to act and should not be harrassed by owners of the road or by petty officers and relatives. The best horse in the world will be ruined by an ignorant man at the reins; so, a well-informed and dutiful superintendent may have his work ruined by an ignorant president or manager, who may possess more money than he, but less brains.

The superintendent should also act as purchasing agent and know every firm that manufacture goods of any kind for electric roads. Not only should he know prices of all kind of materials, as coal and oil, but detail parts of cars, trucks, motors, power station, line and track materials. He must possess good business tact, so as not to fall victim to a smooth-talking supply agent. The superintendent must also understand how to handle the public, from the mayor down; he must have a special face and words sweet or sour according to circumstances; he must investigate every accident, every complaint; know how to handle each to the best advantage. He must also gain the respect not only of every employe but of every man, woman and child in the city, and that he can only do by respecting himself, and conducting himself as a true gentleman.

He must never use vulgar language toward any one. If an employe has done wrong or violated a rule, take him in the office, talk to him as a friend, pointing out the various consequences that might have happened, and you will make that employe not only a better and more careful man but a friend to the company as well. The constant changing of employes and discharging some for slight violation of rules is a costly mistake. When a man is well trained and understands his car and division, he is a very valuable man, and as such should be taken care of. My experience teaches me that every new man costs the company no less the five hundred dollars before he becomes a safe man. Now, some roads change their men just as the fool is beginning to be made wise, and another takes his place. Then the president wonders why his road has accidents and break-downs, and repair bills spring up so heavily, and is worried to death by law suits. No one would be foolish enough to look for a shoemaker in charge of an ocean grayhound, or a whitewasher in charge of an art school. The writer knows from observation that freight conductors, telegraph operators, civil

engineers, linemen, yes, even dry goods men and farmers, are in charge of electric railroads, and then the directors wonder why their road is a failure; and when they meet they sing, "God hath given, God hath taken away, blessed be God's name." There is no business of modern times that is as many-sided as electric railroading, and the men in charge must be as wide awake and smart as any in the world to day. When the history of the nineteenth century is written by the future historian, he will pay a higher tribute to the men who developed electricity as a motive power than to any other geniuses in this age.

Dynamo and motor manufacturers have been partially to blame for losses in electric railroading, for this reason. When they first began to put their machines on the market, they were too light in design and the armatures and fields too poorly insulated. But their glib-tongued agent persuaded the directors of horse and mule lines into converting lines which would not warrant the change; and owners thought to economise by putting in the cheapest possible construction, which soon gave out and the lines speedily came to grief.

Then often manufacturers, when appealed to for brains, to run their broken-down roads, sent out college dudes filled with high-flown electrical formulas and wearing patent leather shoes, with a silk hat on top of an empty head; empty at least as far as an electric railroad was concerned. These young men spent thousands for roads and in many cases left them poorer and worse off than they found them. When the change of motor power began, some roads had nothing in the treasury, as year after year dividends had been declared. Money had to be obtained at any cost, and bonds went flying in the air like snowflakes on a wintry day, and not a few roads assumed too great liability; in fact, more than some were able to meet. As time went on, accidents became more numerous. Not on account of electricity, but by increase of speed, ignorance of motormen, superintendent, and other officers; and damage suits together with interest and repairs, began to play havoc with the nickels. And we wonder why the stockholders are disappointed. We may as well wonder why a paralyzed man does not walk. Too many high-toned pets are employed whose work is small but pay large. Especially is this true in the office. Too many relatives of directors, stockholders, and others, have been allowed to creep into soft berths. Too many bosses exist with most roads. They all represent various experiences, and one gives an order for this and another for that, and they all differ and are jealous of each other.

In the meantime the employes get confused and do not know what to do nor how to distinguish between right and wrong, and as a consequence, everybody from top to bottom is working at a disadvantage.

The superintendent should have absolute charge of the mechanical, electrical and operative departments, and should be responsible only to the president for his acts. He should hire and discharge, educate and assign to their duties all employes, from the chief engineer in the station down to the track cleaner and greaser. The superintendent should have a talk with the president every day in regard to what was done the day before. Any faults found and changes desired should be discussed, and a general understanding should exist between them, so as to constantly improve the road and plug up leaks, allowing nothing to run down, and yet reducing expenses.

#### IDEAL ENGINE FOR DIRECT CONNECTION.

The demand for direct connected engines is daily on the increase, and while at first it was thought practicable to drive only the larger sized dynamos in this way, the capacity of direct connected engine and dynamo units, has been steadily on the decrease, and now very small dyna-

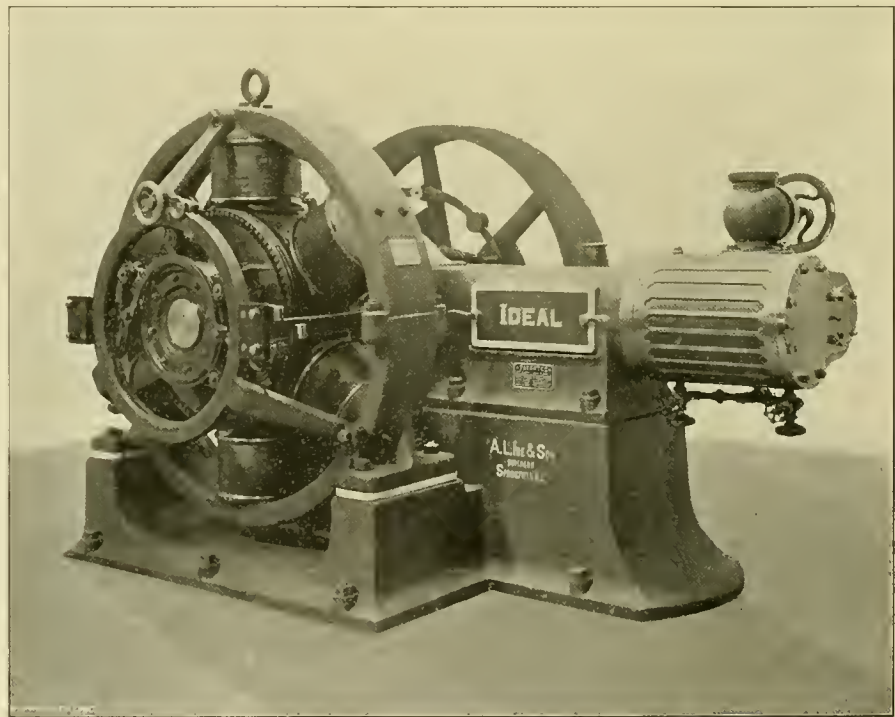

IDE DIRECT CONNECTED ENGINE.

mos are so driven without sacrificing economy to any great extent. Small direct coupled units for ship lighting have been in use for many years, but in that case economy of space was more to be considered than economy of steam or repairs. A. L. Ide & Son, of Springfield, Ill., have re-designed their well known Ideal, so as to make it specially adapted to direct driving. The engraving is of one of three engines that are to light the Southern Hotel, St. Louis. All were regulated to run at 275 revo-

lutions. A direct connected engine must be heavy enough to stand short circuits without breaking itself, and this condition is fully complied with. The coal and repair bills with this type will of course be no more than with the regular Ideal, used for direct belting. The engine in the engraving is 14 by 14, and is rated at 125-horsepower. The armature is of General Electric make and is keyed to the shaft. The Ideal system of self oiling makes it impossible to throw oil on the armature when the engine is taken care of. The engine and dynamo can be put in a box 68 inches high, 81 inches wide and 10 feet 3 inches long.

**THE LOUISVILLE TRUCK.**

The Invention of a Practical Railway Manager.

There are trucks, and trucks. Some are dividend makers and some are dividend takers. In fact, consequent upon the increasing exactions of mechanical traction, no department of supply work has shown such a marked improvement.

To this class of dividend makers has been added within the last two years, another individual known as the

The company also manufactures an elliptical spring truck of exceptional merit, and a trail car truck which has met with great favor by buyers.

The official heads of the Sheppard Manufacturing Company are A. B. Du Pont, president, and S. C. Sheppard, general manager. Mr. Du Pont has been a practical street railroad man for a number of years, and is at present engineer and electrician of the large system of the Louisville Railway Company. He is the inventor of the trucks manufactured by the Sheppard Manufacturing Company, and it is largely owing to his familiarity with the necessary requirements for a good truck, that such high merit is possessed by those being made by his company. The manager will cheerfully answer any inquiries or make estimates for any motor equipment, for any wheel base, for any gauge, and for any number of trucks.

**BRISTOL RECORDING VOLTMETER.**

There is an increasing tendency on the part of large railways to use recording instruments on their switchboards. The accompanying engraving is of the Bristol

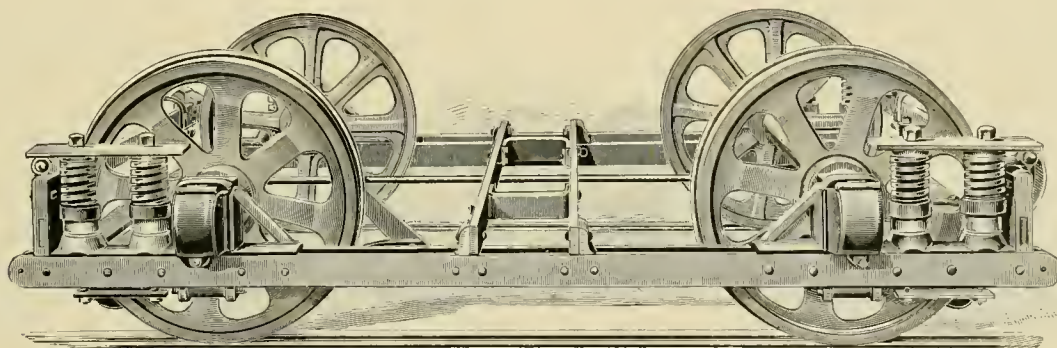

“The truck frame is free from bolts.”

“Louisville Truck,” made by the Sheppard Manufacturing Company, 313, 315, 317 Ninth Street, Louisville, Ky.

A reference to our engraving will show the observer how the claims of simplicity, rigidity, and ease of motion are substantiated. The truck frame is free from bolts, having no separable parts. Rivets are used exclusively, thereby insuring rigidity and strength. The position of the springs is outside the oil boxes for the sake of stability, and the spring base is thus made long relative to the wheel base. A low car floor is allowed for, if desired, by placing the side bar of the truck frame unusually low. This, however, still allows room for the play of springs and the arrangement of the motor.

As to the parts and qualities of the Louisville Truck, it is sufficient to say that a thorough test on the Buffalo Railway, Buffalo, N. Y., the Louisville Railway, Louisville, Ky., and the Southern Electric Railroad of St. Louis has given them the approval of the well known managers of these lines. They are also in use on a number of other lines, and have invariably given entire satisfaction. The oil box used and the dust guard are devices of merit and are appreciated.

recording voltmeter, made by The Bristols Manufacturing Company, of Waterbury Conn. It has the movable coil A and stationary coil B, the current being conducted to

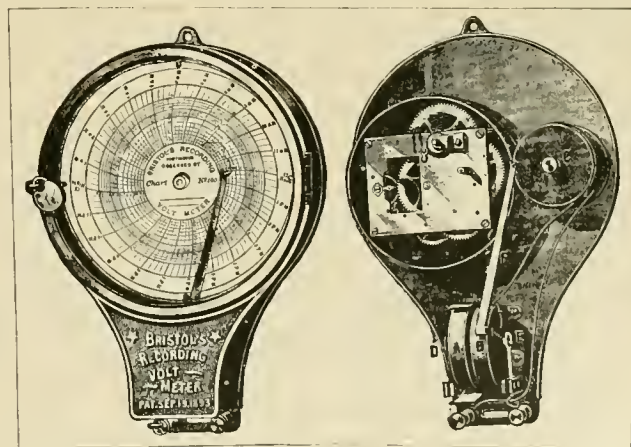

the movable coil through the springs D and E. The divisions are on an increased scale in the vicinity of the normal voltage. The 110 volt instrument here shown, plainly indicates a change of one volt.

## T RAILS FOR STREET RAILWAY USE.

BY JOHN A. BEELER,  
Denver Tramway Company.

Nothing can be plainer to street railway men than that the old style of track construction is a thing of the past. The heavy motor cars of the present day are as much

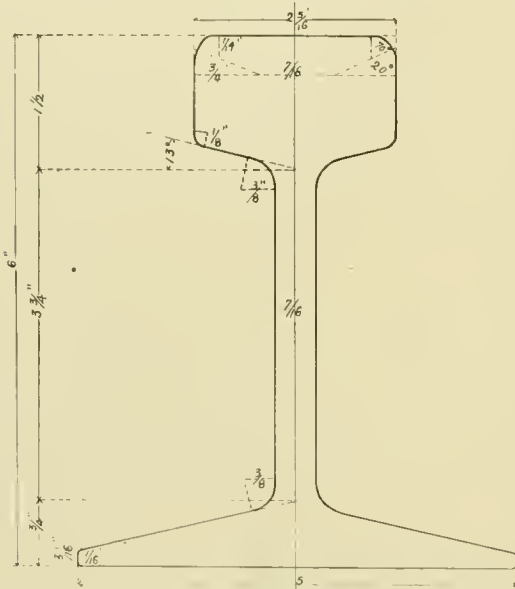

FIG. 1.

72-pound "girder T," specially designed for the use of electric roads on paved streets.

out of place on the old flat rail as the palatial sleepers and great mogul locomotives of to-day would be on the light iron rails of thirty years ago. Heavier cars and

economy and smoothness of track. The only objection to T rail for street use is the supposed impossibility of paving up to it and having as good a surface for ordinary traffic as can be had with other forms of rail.

The 72-pound "girder T," illustrated herewith, was designed by the writer to meet all the requirements of street traffic, causing as little interference with the street surface as any other type of rail and giving the very best results for car traffic. This type of rail, not only in first cost but in ultimate cost, is much less expensive than a girder rail. This rail is six inches high, with a 5-inch base and a broad flat head, the upper corners of which are rounded at one-fourth-inch radius merged into three-fourths-inch radius on the sides. This gives the largest possible contact for the

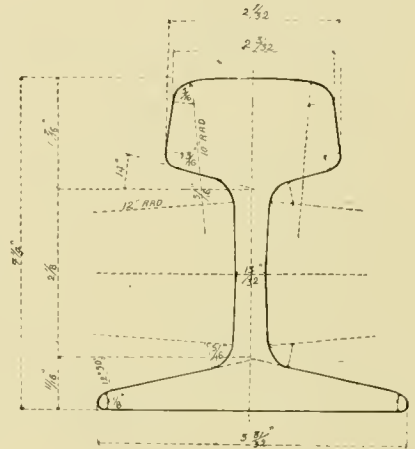

FIG. 5.

Old style 56 pound T used by Chicago, Milwaukee & St. Paul Railway, with general rounded contour of head.

wheels, the importance of which can not be overestimated. The angles of the under portion and the upper portion of the flange are  $13^\circ$ , which affords the angle bars a good bearing. The neck is sufficiently thick to

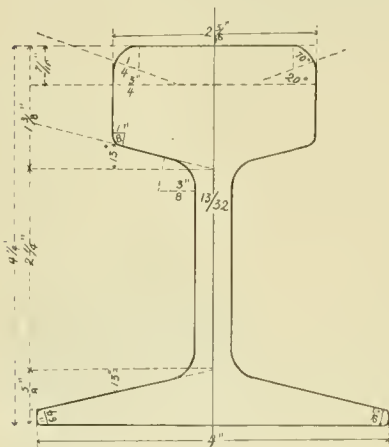

FIG. 2.

56 pound T, designed for electric service in unpaved districts.

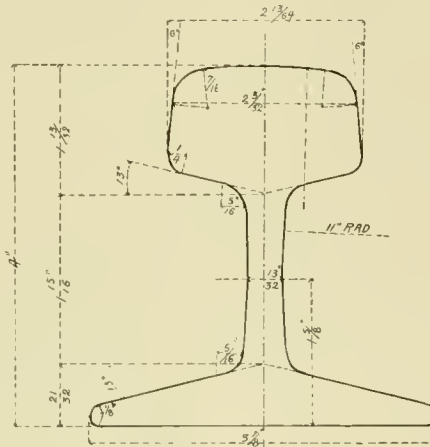

FIG. 3.

Old style 56-pound T used by Union Pacific Railway. Head generally rounded with sloping sides.

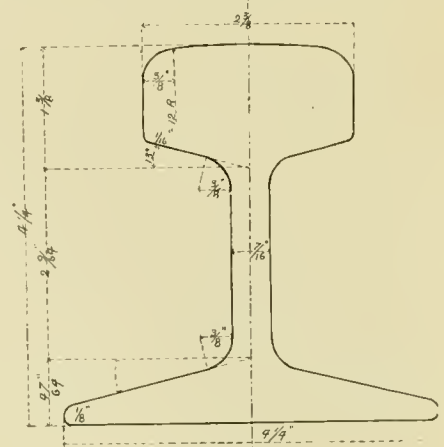

FIG. 4.

New style 60-pound T used by Union Pacific Railway. Head more rectangular; perpendicular sides; sharper corners, and more bearing surface than former style.

engines not only necessitate heavier rails, but better road beds. In the construction of a steam road it is necessary only to consider road bed and rails, but in street railways there is added to these problems that of non-interference with ordinary street traffic. If it were only a question of car traffic the rail question would be settled at once, as T rail is the universal standard for strength, durability,

stand the heaviest electric traction, and the base wide enough to keep the rail in good alignment.

The metal is so proportioned as to give a minimum amount of "cold galling" or straightening of the rails after rolling, which is very large with girders. This process distorts the metal and consequently shortens the life of a rail.

This 72-pound "girder T," as far as strength and durability are concerned, is equivalent to a 100-pound girder rail. One mile of girder T, 113 tons at \$30 per ton, will cost \$3,390, while one mile of 100-pound girder, 157 tons, at \$45 per ton, costs \$7,065. Thus not only is the first cost of the T rail about one-half of that of the girder rail, but the ultimate cost, owing to the greater life of the metal in the T, is still further reduced. This rail should be rolled much harder than the ordinary T for steam railroads. It will be noticed, that of late years the tendency of steam roads even, has been to a T with a much more nearly square, or rectangular shaped head, than formerly used on the same roads. This type of head gives the very best results in the construction of crossings and switches, which is a very difficult and expensive matter with most girder rails.

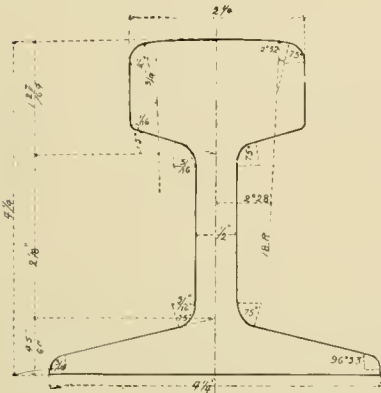

New style 60 pound T used by Chicago, Milwaukee & St. Paul Railway. General squaring up of head; sharper corners; perpendicular sides.

General squaring up of head; sharper corners; perpendicular sides.

for the space between the rails. Both sides of the "girder T" should be paved up to, either with stone blocks cut to fit as shown in Figure 7, or with oak strips as shown in Figure 8. The latter must be thick enough, on the inside of the rail, to leave a clear space for the wheel flange. If there is a joint between the wood and the blocks directly under the wheel flange, dust and sand will be forced into it and the paving will eventually be bulged

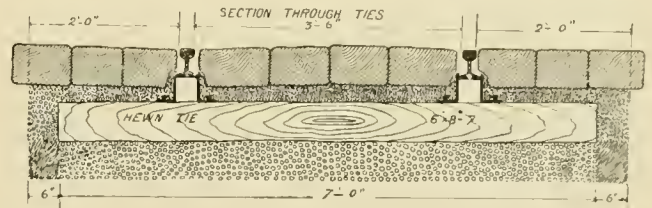

Ordinary T rail on chairs, with stone block pavement, (or asphalt, with toothing). Blocks between rails eventually bulge up from action of wheel flanges, forcing dust and sand under blocks, and consequent action of water and frost.

upward. If the blocks of wood and stone, or stone alone, are arranged as shown in the foregoing illustrations, with the joints of the blocks abutted closely, properly filled with hot fine sand and coal tar, the blocks will be held perfectly secure and cannot settle or bulge.

The cost of properly shaping the blocks to fit the "girder T" is no more than the cost of properly fitting blocks to any other rail, (indeed to properly fit blocks to

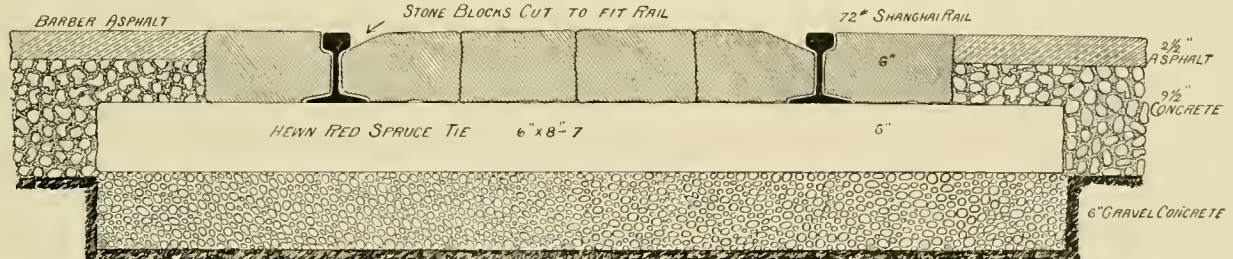

72-pound "girder T" rail, in stone block granite or asphalt. Blocks cut to fit rail, making it impossible for them to bulge or settle.

Permanent pavement and a solid track require a good foundation. A continuous bed of concrete the full width of the tie and at least six inches deep, distributes the load over a large area, is waterproof and makes the most

some girders is an impossibility). Given a track constructed as above described, there is a great saving in the wear and tear of cars and motors, as well as in the maintenance account, but a gain of still greater magni-

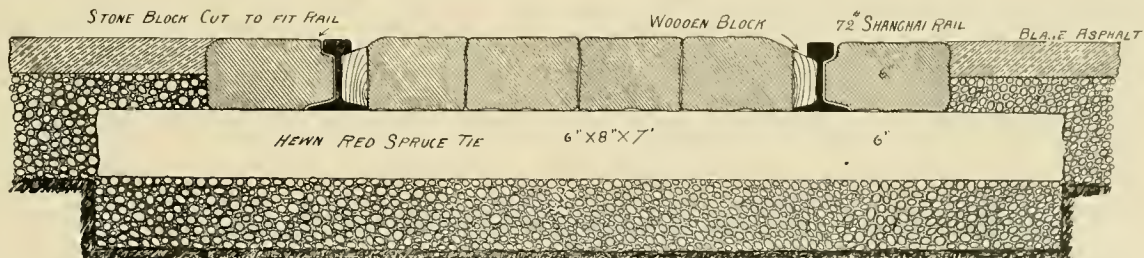

72-pound "girder T" rail, in stone block granite or asphalt. Oak strip fitted next to rail between ball and flange; narrower strip not to project beyond ball; may be fitted on outside of rail; stone blocks abutted closely, making bulging of pavement impossible.

permanent foundation. The space between the ties should be filled with concrete also, making a foundation for the pavement.

Block pavement has been found the most satisfactory

tude is made in the saving of electrical current necessary to operate the system. To the above may also be added the gain in traffic that comes with comfort and ease in riding. Nothing but prejudice can prevent the ultimate

adoption of this, or a similar type of rail, by all our street railways. Municipal legislation may stand in the way for a time, but practical demonstration, backed by economy of cost, will very soon drive out prejudice.

The public are entitled to and should have, as easy and comfortable transportation to and from their homes, by means of their conveyance, the street car, as have the comparatively few who can afford the luxury of a private carriage.

THE large number of letters we are receiving from street railway men throughout the country on the question of pleasure resorts as a means of creating travel, is at once surprising, but shows what interest the articles in the REVIEW on this subject have occasioned. Now is the time to make leases of grounds and get them cleared and all preliminary work done, and next summer the crowded cars will make you glad, while the returns from the refreshment concessions will be a real power in the financial community of your road.

ELECTRICAL toys this season were well in demand. Launches were popular, and even a miniature electric railway was bought by a few far-seeing parents, that little Willie might grow up to be a street car magnate. The complete toy railway comprised a motor car, three trailers, and some track. A small battery actuates the motor, which is single reduction, 7 to 1, and requires half an ampere at six volts.

#### A DISTINGUISHED CANINE.

Ponto, whose portrait we present to the dead-head fraternity, with our respects, is perhaps the only four-legged dog owning a pass on a street railway. Ponto is a big shaggy canine belonging to the Newfoundland breed and to Civil Engineer Farnsworth of Kansas City, Mo. One day, Mr. Farnsworth, accompanied by Ponto, boarded a Metropolitan street car, the conductor of which promptly ejected the dog with the aid of a switch-hook. Ponto took the matter philosophically, but Ponto's master didn't. The latter went immediately to the officers of the company and laid the indignity suffered by Ponto before the manager. The manager was struck with Ponto's worth, and immediately issued a pass to Mr. Ponto, who is thus blessed above all dogs of Kansas City, both



PONTO FARNSWORTH.

"Pug dogs, terriers, beagles,  
hounds,  
And curs of low degree"

The consequence is, that Ponto travels on a pass which hangs from his collar. Ponto is a well-known Kansas City character, good natured as a kitten, and never makes a mistake as to a Metropolitan car.

#### THE WALKER MANUFACTURING COMPANY.

The surprise occasioned by last month's announcement that the Walker Manufacturing Company, of Cleveland, was to enter the field of manufacture of electric street railway motors and apparatus, was as widespread as the confines of street railwaydom.

It is true, nevertheless.

H. McL. Harding and J. L. Barclay, of Chicago, both well-known in the street railway field, from the beginning, are associated with Mr. Walker's energy, enterprise and capital in this new undertaking. Both Mr. Harding and Mr. Barclay have served long apprenticeship in the old Sprague, and later, with the Westinghouse Company.

Readers will remember the REVIEW's write-up of the Walker works and their fine facilities, two years ago.

Mr. Barclay will manage the Western business from Chicago, while Mr. Harding will make his headquarters in New York.

#### THE BROOKLYN L AND THE ELECTRICS.

The annual report of the Brooklyn Elevated Railroad Company shows that the surplus at the beginning of the year was \$195,295, of which \$117,380 was earned in 1892. In the year, three miles of track and nine new stations were completed, making twenty miles in all. In 1892 37,314,640 passengers were carried, and in 1893 only 35,926,359, a drop of 3¼ per cent in spite of the extensions. The surplus has been reduced to \$178,180. The report pathetically says, in substance, "We attribute one-half the falling off to business depression and the closing of factories. The other half is attributable to the increase in the number of trolley cars, which run at such reckless speed. We think that, not the use but the abuse of electric traction is responsible for our loss. It should not be allowed on the streets of a great city." New directors were elected in the persons of Albert A. Drake, Austin Corbin and Henry Seidenberg.

The Kings County Elevated reports a deficiency of \$37,000 to the railroad commission for the quarter ending September 30. The figures are:

	1893	1892
Gross earnings.....	\$160,589	\$195,740
Operating expenses.....	125,428	128,654
Net earnings.....	\$35,161	\$67,086
Other income.....	-----	144
Gross income.....	\$35,161	\$67,230
Fixed charges.....	93,549	91,039
Loss from operations.....	\$58,388	\$23,809
Cash on hand.....	\$65,472	-----
Profit and loss, deficiency.....	37,151	-----

The cause is, electric railways paralleling and crossing the routes of the elevated, with the greater comfort of the latter bidding against all the advantages of the former.

THE Galveston, Tex., roads threaten to resume horse traction if a 7-mile speed ordinance is passed.



## BIG CAR ELEVATOR ON THE WEST END.

An interesting electric car elevator here illustrated, was designed and constructed by Geo. F. Lauthlin & Company, Boston, for the Bartlett street car house of the West End Street Railway Company, where it is now in regular use, raising the completely equipped electric cars, which weigh about 20,000 pounds. The platform of this elevator is 40 feet long, 12 feet wide, weighs about six tons, and carries a system of locks which support the platform at the floors, rendering it rigid while running on and off the heavy cars.

The machine is supported on eight 10-inch I beams

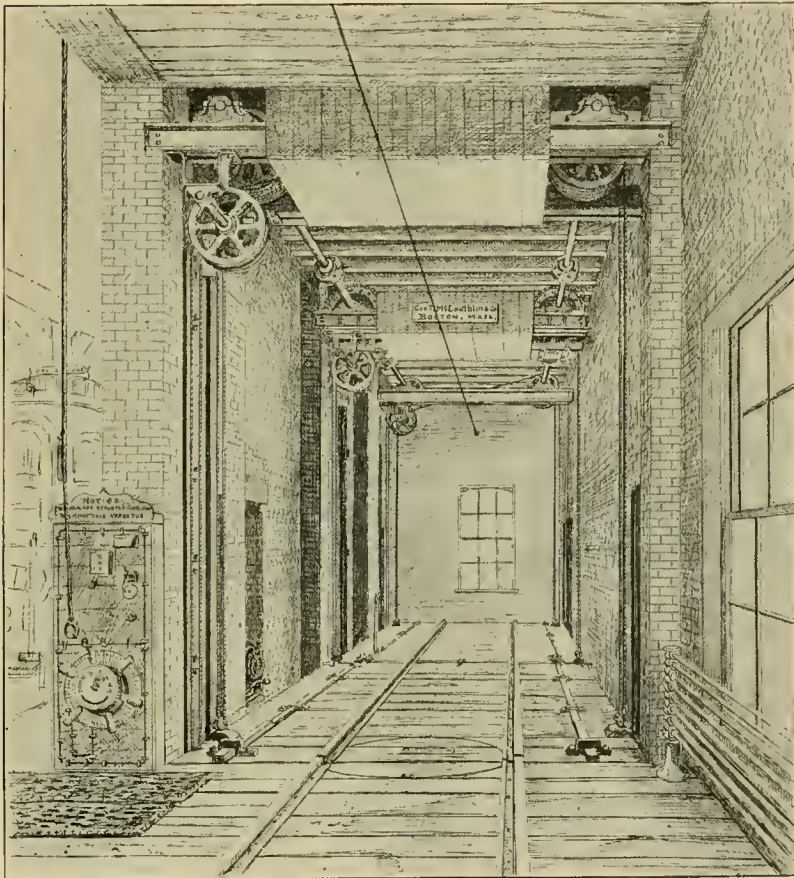

ELECTRIC CAR ELEVATOR.

directly over the wellway. This machine comprises two 4-inch steel drum shafts, carrying six drums and driven by four worm gears, two of which are keyed to each shaft and arranged in such a manner that there are no thrust strains. The pinion shaft is provided with a simple and efficient brake. Power is communicated to this shaft by an 8-inch leather belt from a 25-horse-power Thomson-Houston car motor. Twelve  $\frac{5}{8}$ -inch hoisting cables are connected to the platform at six points, and the power applied to move the load is thus distributed over the whole area of the platform. Three heavy counterbalance weights are so connected that these weights may very considerably overbalance the platform and very materially reduce the amount of motor power required to raise a given load.

The rheostat is secured to a conveniently located switchboard and is operated by the right hand while the brake connection is held in the left hand. The movements of the platform are under the perfect and instant control of the operator.

This design of elevator was accepted by L. Hirt, the master mechanic of the West End Street Railway Company as the best of the several competitive designs submitted; its operation has proved particularly satisfactory.

THE Paterson & Little Falls Electric Railway began carrying mail to the latter place January 1.

## THE SAME OLD TOWN.

He was coming down Broadway, doing the prodigal act of the returned old resident, says the New York Herald.

"Oh, yes; the town has grown," he admitted, "but it's the same old place after all. It's nearly forty years since I lived here, but things look as familiar as though I left but yesterday. A little improved, but still the same old town."

The new Opera House was called to his attention.

"Jes' so. Same old place. New building, to be sure, but same old location. When I was a boy we used to come here to"—here the strains of a brass band attracted his attention.

"Ah, ha! Old friends again. Same old outfit, tune and all. Used ter play that when I was a boy to"—

His attention was riveted on one of the fine new hotels on upper Broadway.

"Dear me! How little time does change. New building, of course; but same old make-up; news-stands, lunch-counters, bar, office; the same throughout. Would have known the place in the middle of Asia. Now, when I was a boy we used to"—

He was crossing the street as he spoke, and in spite of his companion's efforts, a cable car

lifted him from his feet and landed him several rods ahead on the pavement. When a policeman hurried forward to help gather up his remains the old man rose and exclaimed:

"Same old trick, by gum! Them coasters never will yell 'track' in time. Gosh! how we used to sail down that hill when I was a boy. It makes me young to think of it again," and he went on down street, murmuring, "Same old town. Same old town."

A TEXAS genius has acquired notoriety as the inventor of a new rapid transit bicycle, which, of course, will "revolutionize the world." The inventor claims that sixty miles an hour is rather slow speed on good roads.

## CRADOCK ROPES BREAK ALL RECORDS.

If there is any road in the country which demands good quality and construction in its cables, it is the North Chicago Street Railroad, and of all its lines that of its down town loop, which passes under the river through the La Salle street tunnel is the most severe. Not only must this loop handle all the cable cars of all the lines on the north side, but must operate around four severe curves and make the depression at the bottom of the tunnel, all under very heavy tension. The short life of all other makes of cable did not discourage the George Cradock Company, of Wakefield, England, from entering this discouraging field. The third of their ropes has just been taken out and the records are as follows: one ran ninety-three days; the next, seventy-eight days, and was then in good condition when ruined by a careless grip-man; the third, the record-breaker, ran ninety-eight days, from August 27 to December 2, and hauled all the heavy business which marked the last two months of the Fair, including the ever famous "Chicago day." This rope is 9,760 feet long; ran at seven miles an hour, and the first splice ran eighty-three days. The American ropes in this loop have averaged thirty-five days, while the average use of the Cradock rope has been a fraction over eighty-nine days, and the last, after ninety-eight days'

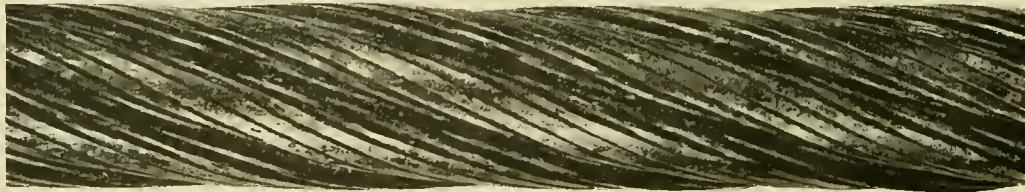

THE RECORD BREAKER RAN 98 DAYS.

work, is still good, and will be again put in service on the south Clark street section, which has no curves and where it promises still further good returns. The rope is 1 3/8 inches diameter, of the well-known Lang lay, and is composed of six 10-wire strands wound around a tough hemp center. Our illustration is a section of the ninety-eight day rope, and is a fair representation of the condition of the entire rope. It will be noticed there is not one broken wire, and our own examination of the cable shows very few wires worn thin.

The North Chicago road has just placed an order for five new ropes of the Cradock make, to use on the tunnel loop already mentioned, and also one rope of 22,000 feet to go on one of the main lines. J. E. Hartley, the splicer, reports there were no delays whatever arising from any fault of the rope during the entire ninety-eight days, and even hopes for a better record in future, although Superintendent Roach will doubtless feel satisfied if history will only repeat itself.

A THOMASTON, ME., man, has been awarded \$1,000 damages for being ejected from a street car for alleged profanity. The conductors are now very careful about sifting out swear words from ordinary conversation.

## BOSTON'S SUBWAY SCHEME.

The general topic of the good citizen of Boston, now-a-days, is the "coming" subway, as it is denominated in the papers.

Various schemes for relief, in the congested districts, have been promulgated, all based on the following tabulation of traffic:

	Population.	Steam Ry. Passengers.	St. Ry. Passengers.
1871.	515,000	17,000,000	34,000,000
1881.	665,000	25,000,000	68,000,000
1891.	850,000	51,000,000	136,000,000

Not only is the above table instructive, but the following shows that rapid transit increases the trips per inhabitant:

	Trips per Inhabitant.	Trips per 100,000 Population.
1871.	99	19
1881.	140	21
1891.	220	26

The above calculations are based on the metropolitan area, that is, within ten miles of the old state house.

The "best authorities" have, for several years, been debating rapid transit, while the world-famed West End Electric Railway has been giving the Bostonese satisfactory transportation. The elevated railway system sanctioned by the legislature, has failed to secure enough

money to enable it to build. The underground scheme has dismal prospects. In fact, the solution of the problem is not yet worked out by any trustworthy plan.

The proposed subway, which promises relief by tunneling under the busiest part of the city, has so little to commend it, that it is doubtful if anything more than talk will come of it.

Meanwhile the West End carries the people.

ONE of the queerest sights, at the now dismantled Jackson Park, is the odd idea of the Intramural railway hauling itself away. The road is changed into a freight line, and flat cars haul the timber and rail to the south loop as fast as they can be broken up. A motor car with an enclosed cab does duty as a freight engine.

Carl Rohl-Smith's statue of Benjamin Franklin has been taken from the south entrance of electricity building and shipped to Philadelphia, to which city the director's presented it.

ALL the talk about the consolidation of the Paterson N. J., and the Central Street Railway Company is said to be false alarm.

AN OTTAWA, CANADA, INCIDENT.

(Written for the REVIEW.)

She was a meek looking woman of about thirty-five, and enquired at the outside office in a semi-apologetic manner if I was in. I gave her a chair. She said, with apparent embarrassment and hesitancy, which proved, however, to be only apparent, that of course I had heard of it. I assured her in an interrogative tone that I had not. Her eyes, which had been intently fixed on the floor, were now raised and glanced at me with a look full of doubt; then without further hesitation her tongue was unloosed, and, sans commas, sans periods, sans everything but words, she told me all about it.

"I always take the cars they are so convenient and the conductors and motormen so civil with their buttonhole flowers and the bells ringing at the crossings and indeed

had rights being Yankees not that I have anything against them for I lived in Watertown two years and do you think the company will pay for Mary's shoes and fixing the buggy?" \* \* \*

BEARDSLEY'S INSULATING OIL PAPER.

Another addition to the list of first-class insulating materials has been made in the form of a high-grade oil paper for use on armatures, fields and converter coils. It is made in sheets 21 by 30 inches and can be folded or formed to the work without cracking or tearing. As a matter of course, it is waterproof and will resist the stress of high voltages. The maker is the Beardsley Manufacturing Company, of 234 Lake street, Chicago. Samples can be had on application.

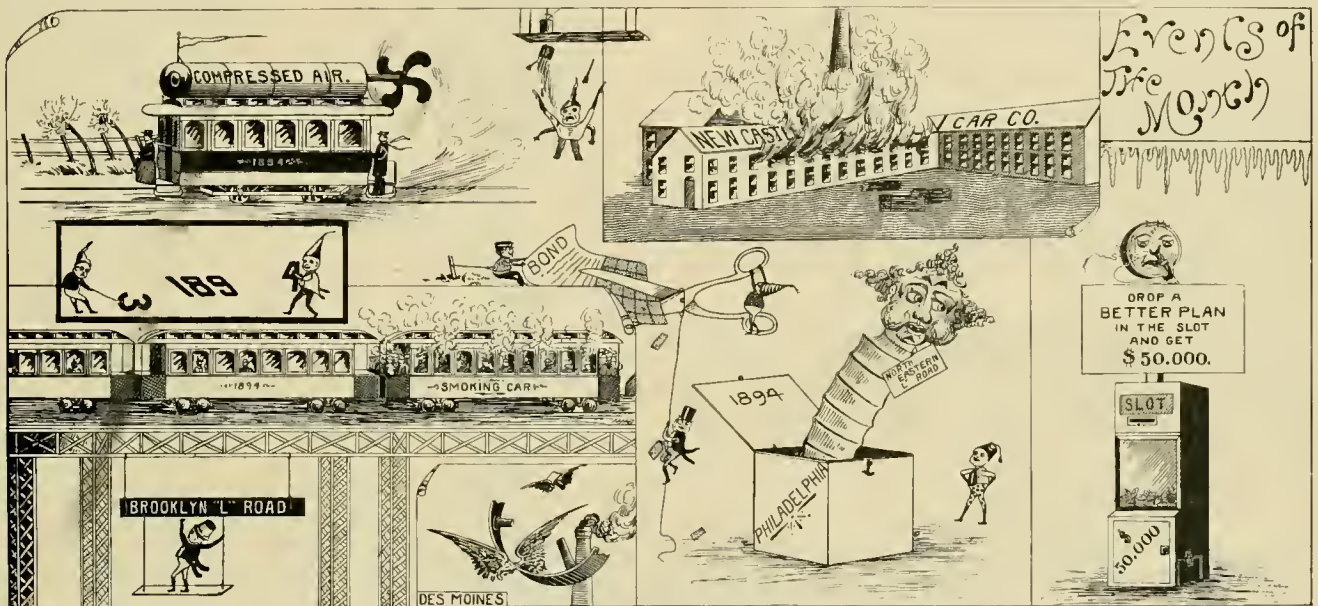

PICTORIAL EVENTS OF THE MONTH.

DAVIS TOWER WAGON.

The accompanying illustration is of the tower wagon, manufactured by W. S. Davis & Son, Concord, N. H. While capable of being raised to nearly the height of the wire, it is when lowered but very little higher than the

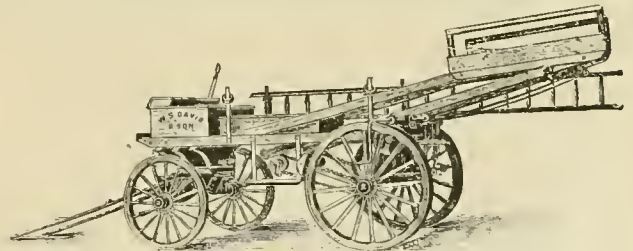

driver's head. It is raised by a crank and chain, the crank being over one rear wheel. The working platform is roomy and the wagon is fitted with tool chest, brakes, and everything necessary for ordinary line work. The excellent quality of everything coming out of the Davis factory insures that this tower wagon is something reliable.

sometimes where there isn't any but this morning said I to Mary we'll take the mare she's well bred and the boss when he bought her from Mr. Johnson didn't know her feet was tender men selling horses don't tell all and as we turned in near the fence where Rogers is building his store and his prices were high enough in the old one she stepped tender and slow like and all the men on the street said he didn't ring his bell and the carriage man says it will cost thirty-five dollars to fix it and her new shoes only got Saturday night a week ago were cut right across and out she went like a ball for it was a mercy we weren't killed and the conductor taking the names of everyone who saw it and I wouldn't mind the loss if we hadn't to put in a foundation to raise the house higher for the boss gave it out by contract to different trades and the man that was to put in the foundation didn't turn up until the others had finished and the plaster near the back stairs is all cracking and when we were moving in the shooters in the Electric Park fired a bullet through the window and what would I have done without my boy with two eyes if he had been near the window and they said they

## BUCKLAND'S BIG BID.

George G. Buckland applied for extensive franchises to the board of supervisors, January 3, at San Francisco. The rights wanted are very extensive, and the promises made for the return of the compliment are very liberal.

Mr. Buckland pledges himself to begin work in thirty days, to spend \$50,000 in sixty days, \$200,000 in ninety days, \$500,000 in six months, and to have the whole road in operation in three years' time. In addition to the 2 per cent gross annually, to which the city is now entitled from the earnings of a cable company, he offers to pay to the city 5 per cent weekly of the gross earnings, as a bonus for a fifty-year franchise.

## THE WEIR FROG COMPANY.

Some of the most intricate special track work in the street railway field has been designed and made by the Weir Frog Company, of Cincinnati, O., manufacturers of Fred C. Weir's improved steel rail frogs, crossings, switches and special work. Some notable contracts among street railways are found on the lines of the Baltimore City, the Lake Roland Elevated, of Baltimore, the New Orleans & Carrollton, of New Orleans, the Alley L and the Calumet railways, of Chicago, and the Consolidated, of Cincinnati.

The improved track work resulting from rapid transit is fully provided for at the Weir factory, by a complete equipment of special machinery, some of it of their own design.



"The first section carried twenty-seven cable cars"

## COMMON CARRIERS CARRIED.

When the West Chicago Railroad some time ago wanted fifty new cars, they placed the order with the American Car Company, of St. Louis, and one condition of the order was that the new cars were to be gotten out in short order and all delivered at one time. President Sutton was as good as his word, and when the cars were completed, chartered a special train for shipment. On account of its length and weight, it became necessary to run the train in two sections, the first of which, carrying twenty-seven large cable cars, we present in our engraving.

## VESTIBULES AT DU BOIS, PA.

The accompanying illustration is of the vestibule put on the Du Bois Traction Passenger Railway by Superintendent S. R. Smith. Mr. Smith's views on the vestibule question are, that during the cold winter months they not only protect the motormen, but give the cars a comfortable appearance, while on the other hand, in hot weather they look cumbersome and uninviting. For this reason he has had vestibules made so that they can be removed and put away in the car barn in the spring. The vestibule is made in three sections or parts; one section on the front and one on each side. They are fitted together nicely and firmly fastened to the car.

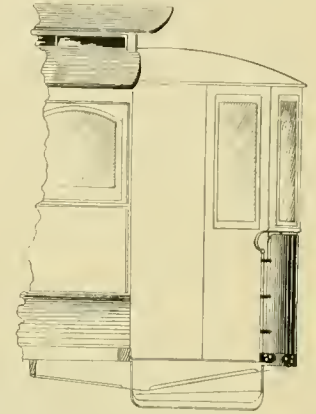

Each part is numbered so that there will be no trouble in replacing them after being removed. With one exception, the vestibules are made of ceiling costing \$15 per car. Vestibules of paneled work cost \$25 per car. They weigh 70 or 80 pounds.

H. P. PAGES, has been reinstated as superintendent of the Salem division of the Lynn & Boston Street Railway Company.

## ACCIDENTAL DEATHS IN CINCINNATI.

The coroner's office at Cincinnati made "crown's quest" of 311 cases of accidental death in 1893. Suicide claimed 65; drowning, 48; railroad accidents, 61; faith cure, 3; cable cars, 3; horse cars, 5; electric cars, 19; death by falls, 26; run over by wagon, 9; burned, 13; suffocated in bed, 10. Thus it would seem that the "deadly faith cure" is on a parity with cable cars; while the "deadly bed clothes" are twice as fatal as horse cars, and of the hundreds of thousands of people carried on the electric lines, only 19 were fatally hurt, while of the few using steam cars, 61 required the coroner's attention.

THE KNAPP SWIVEL TROLLEY FORK.

That the swivel form of trolley fork is a valuable and trolley-wheel saving device, many who have tried it will testify, and it is therefore gratifying to learn that Arthur S. Partridge, of St. Louis, has put one on the market, so that all will be able to try the unquestionable merits of this style. With a swivel fork the wear on the trolley wheels is confined to a narrow groove instead of being greatest on the flanges. Of course, with this condition of affairs the wheel will last much longer. The engravings

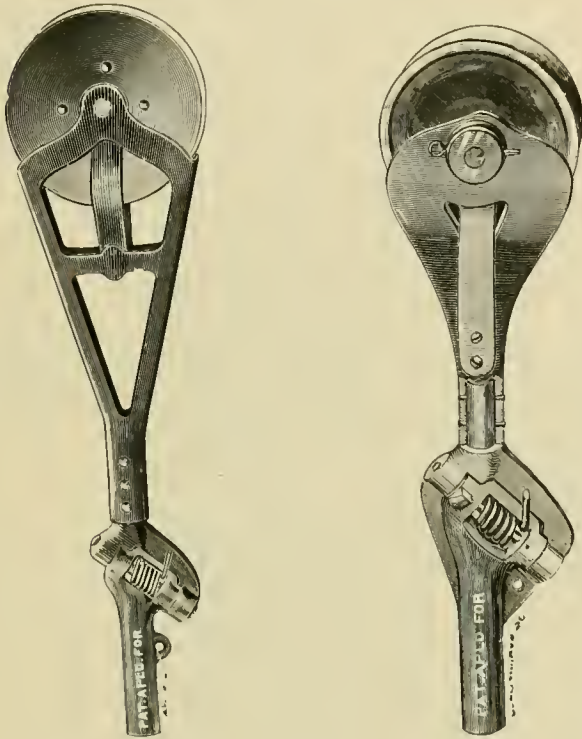

of the Knapp swivel forks fully explain themselves. The fork is kept from swinging around too freely by the spiral spring at the joint. Thus the fork is kept in line and at the same time allowed play enough to turn any curve. How well the swivel trolley does its work is judged from the way the wear comes on the wheel as mentioned above. This proves that the wheel always adjusts itself to the wire on curves or with crooked poles. The wear on the overhead work as well as the wheel is thus lessened. The swivel fork can be attached to any trolley pole with slight cost. The Knapp forks, after being tested for several months, have been adopted by both the Lindell Railway Company and the St. Louis & Suburban Electric Railway Company.

The destiny of the new device is in first-class hands, and its fame is rapidly becoming known.

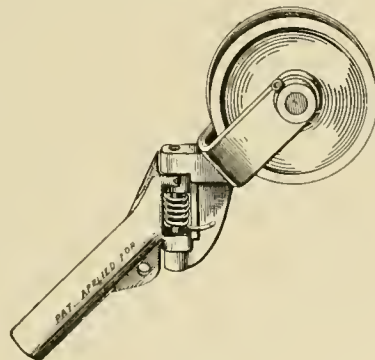

MAYO'S AUTOMATIC TROLLEY CUT-OUT

The accompanying drawings show the action of an automatic trolley cut-out, invented by H. N. Mayo, of 206 Columbia building, St. Louis. It is adapted for use with bracket construction. Along the length of the trolley line are signal and cut-out wires as indicated by 4,4, in

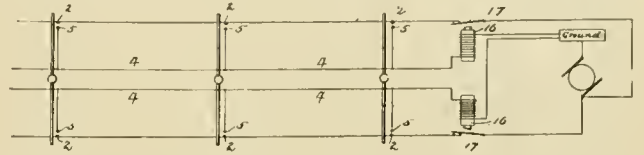

FIG. 1.

Fig. 1. These wires are connected through trolley circuit breakers to the ground. When contact occurs between these wires and the trolley lines 2,2, the trolley circuit is, of course, opened. Over each trolley hanger is a bridge consisting of a short piece of wire. When the

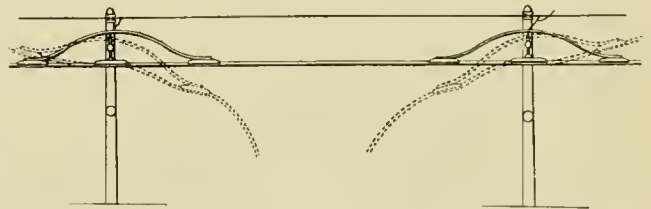

FIG. 2.

trolley line breaks, this bridge is pulled down so as to make contact with the cut-out circuit, as in Fig. 2. If the trolley line is sectioned the cut-out circuits may be brought to a station annunciator so as to tell on what section the break is.

A GREAT SCHEME.

LOAFERS at the street railway power house at Aurora have become so numerous and bold that even a lock and bolt were forced, in order to open up to the warm room for the benefit of tramps. Now, engineer Hadin is a kind hearted man, but even his patience has an end. It did in this case, and his remedy was effective if violent. To the brass knob of the door, he fastened from the inside, a live wire from the trolley circuit. Now the occasional gentleman of leisure, who is not cognizant of the scheme, gets a notice to "keep out" and the impetus to acrobatic feats all at once.

THE West Chicago gave its usual ten days furlough, or cash equivalent, to 40 men. Mr. Crawford approves the plan warmly. The North Chicago gave four gripmen, \$75 first prizes, and twelve \$25 second prizes, for freedom from accident. Mr. Roach thinks the method is beneficial to the service.

THE first season of the Niagara Fall Park & River Railway shows a good record. Since May 24, 417,908 people have ridden over the line. The double tracking of the road is about finished, and the work of constructing new bridges progresses well.

## A STREET RAILWAY ELECTRIC PARADE AT HOUSTON, TEX.

It was arranged by the business men of Houston and the steam roads entering that city that Houston should on December 7 be the Mecca of a holiday excursion from all neighboring towns, and when the program of entertainment for visitors was arranged one of the prominent features was an electric street car parade. It proved to be a drawing card, and the largest crowd of people ever brought together in the streets of Houston to witness any street attraction, was the result. In fact it was difficult to get the regular cars through the crowd. The city was in holiday attire and all cars were decorated with flags, bunting, boughs and flowers. The operating plan of the street railway company is such as

amid music and the fitful glare of Roman candles and burning powder, presented a weird and picturesque effect.



SUPT. MUNDES.

Superintendent Frederick Mundes, whose portrait is here presented, gave the details of the display his personal supervision. Mr. Mundes has worked up from the position of driver in the short space of eight years, having been appointed to his present position in 1889. The conception and promotion of the street railway parade

scheme is due to General Manager MacGregor. The parade was a much greater success than any one anti-

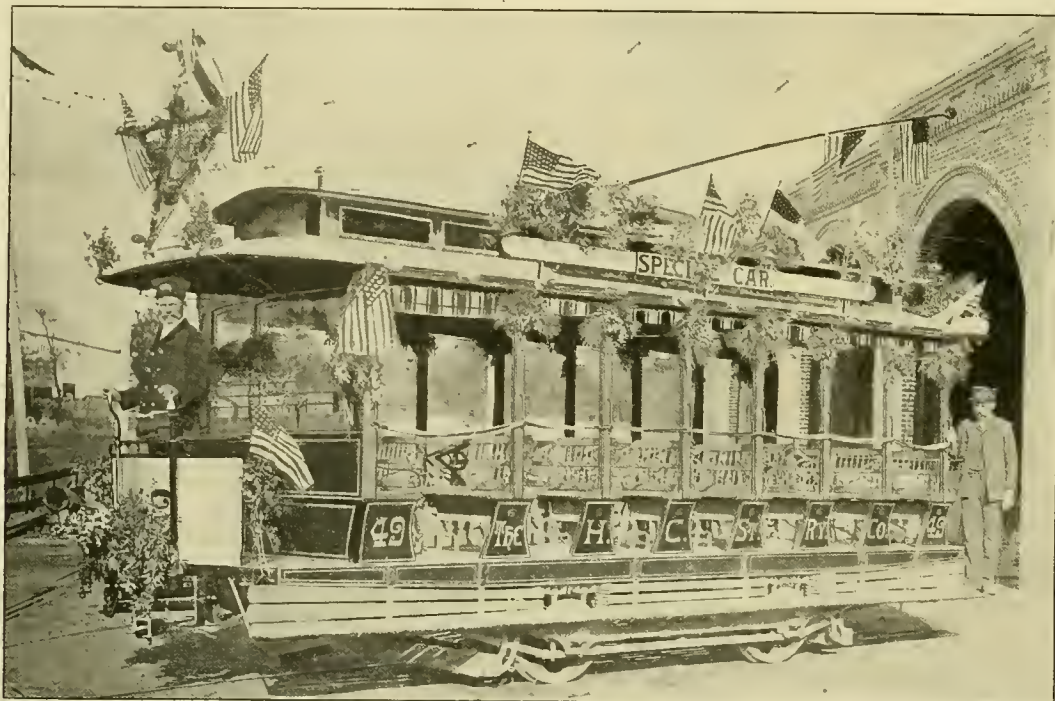

to make the display specially effective. All cars from the thirteen lines run around a loop ten blocks long, in the business district. The day parade consisted of a train of special cars which were filled with visitors, and operated around the main loop together, followed by the regular cars. The special cars were then distributed over various lines to enable the visitors to see Houston Heights, the industrial establishments and the residence portion of the city.

The night display was most attractive. The special cars were decorated with various colored incandescent lights. The head car had a Texas star on the bonnet, covered with electric lights arranged to flash different colors. A band of music occupied the front car. The electrician was ornamented with an electric light projecting from his hat, one on each shoulder and one for a shirt stud. The electrically decorated cars, gliding along

pated and Mr. MacGregor thinks that doubtless such exhibitions will become a feature of many public entertainments in the future.

### A NEW BRIDGE.

A scheme to bridge the Kill von Kull will connect New Jersey with Staten Island. The Consolidated Traction Company, which owns all the near-by lines, and certain Philadelphia parties, are concerned in the matter. John D. Crimmins represents the undertaking. Among others interested in the project are said to be: A. J. Cassett; Frank Thompson, vice-president of the Pennsylvania Railroad; C. A. Griscom, Senator William J. Sewall, B. M. Shanley, Thomas DoJan, P. A. B. Widener, William L. Elkins, William C. Whitney, John S. Waterbury, Senator James Smith, jr., and John D. Crimmins.

### THE EDDY MULTIPOLAR GENERATOR.

The Eddy Electric Manufacturing Company has recently brought out a multipolar generator in capacities between 52 and 360 kilowatts. The frame is of cast iron, to which the soft steel pole pieces are bolted, the bolt heads all being below the surface of the frame. The field coils are wound on insulating spools, and these spools are sup-

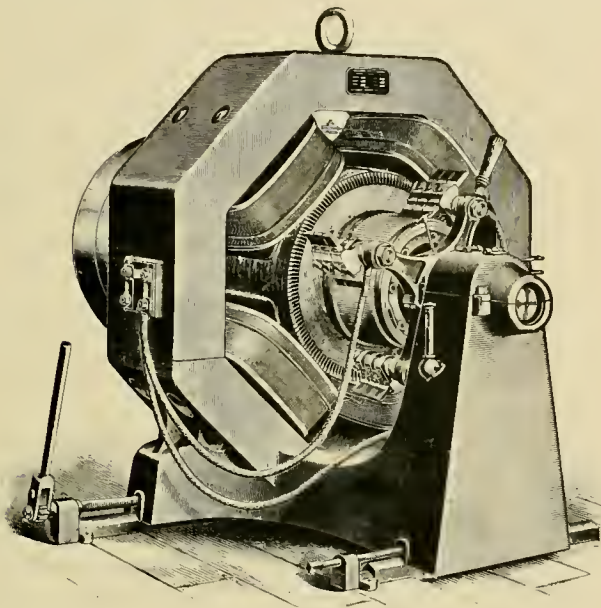

EDDY GENERATOR.

ported so as to leave an air space between the coil and core. The pole pieces have enlarged ends. The shunt and series coils are in separate compartments. The armature core has ducts through which the air is drawn from the center by centrifugal force. The conductors are rectangular copper bars embedded in grooves. The end connections are made with flat copper ribbon.

### INDIANAPOLIS.

The city of Indianapolis is enjoying rapid transit service of the highest type, under the direction of Thomas McLean. The management has labored through much trouble to a full understanding with its employes, who had become tired of the ring rule of certain of the so-called labor leaders, and finally the local "union" of employes was dissolved by consent of its members. This action completely unsaddled the agitators to the great joy of the employes. The agitators, with their occupation thus gone have had, as may be supposed, no love for the management of the railway or for law and order. Manager McLean received several threatening letters, an account of which appeared in December's REVIEW. The company now thinks that only by the vigilance of the detective service has it escaped damage to its property. At least, it is said, a plot was discovered to ground the current at various points and to otherwise interfere with the running of the system. Dynamite was talked of by the conspirators, but lack of courage seems to account for the plans not being executed. The

city papers were appraised of the scheme and the police department has the conspirators under surveillance. Faithful employes will have no occasion to regret their loyalty to Mr. McLean, and the citizens of Indianapolis may hope for the complete electrifying of remaining horse lines as a sequel to a now highly satisfactory service on the trolley system. In bringing discipline out of disorder and in establishing good management, Mr. McLean has made a notable record.

### TELEPHONE PATENT TO EXPIRE.

On January 30, 1894, what is believed by experts to be the last of the fundamental patents on the modern telephone will expire, and one of the most offensive monopolies in the history of the electrical business will be broken. As to its influence on present telephone exchanges in large cities, there is a difference of opinion, but there can be no doubt that its use in private exchanges will be greatly increased. On street railway systems, especially, the installation of private instruments ought to receive a new impetus. In September, 1892, we published an article by Superintendent C. K. Durbin, of the Denver Tramway Company, describing the system of car starting by telephone as practiced on his lines, and it was shown to be incomparably superior to either the starter or the time card system for roads of any size. In addition to this, there are many other places around railways, both large and small, where telephones could be used to great advantage. That a road should have its own private system is obvious. It has poles, linemen, and everything necessary to install and maintain a private exchange with but little expense. Such being the case, it is useless to pay to help maintain a city exchange. It is often of great value to have telephone lines for testing purposes. The drop in potential in both overhead lines and ground return can be more easily determined in this way than in any other. Since it will not be necessary to pay a yearly tax on each instrument, there need not be as much hesitation about incurring the expense of a few telephones in possibly useful places, as formerly. The value of the telephone as a time saver in emergency cases cannot be overestimated. Telephone boxes instead of alarm boxes could be installed with advantage on some large systems, so that the wrecking force at the barns would know what to expect. A large number of companies are now placing telephones on the market, and 1894 will undoubtedly see a great activity along this line.

The Western Telephone Construction Company whose advertisement appears elsewhere, are making specially arranged apparatus for street railway service. Among the features of it are the outlying stations, much the same as the present police patrol house, within which the instruments are located. The apparatus has automatic switches in connection with the lines, so that each station can communicate with any other without operating service.

## ANNUAL MEETINGS OF CHICAGO ROADS.

The transportation companies of the city all hold their annual meetings near the close of the calendar year, and of those already held we give a condensed report below. The Chicago City holds its election January 16.

## THE WEST CHICAGO REPORT.

The Columbian year on the west side showed gross earnings of \$5,235,633, an increase of \$615,408. The operating expenses were 55.25 per cent of the gross earnings or \$2,892,982, an increase of \$205,671, leaving a net of \$2,342,651, an increase of \$409,736. After deducting the coupon interest, rent of leased lines, fixed charges, the balance applicable to dividends was \$1,400,901, of which \$991,559 was so applied, carrying \$409,342 to swell the surplus to \$1,862,851. Mr. Yerkes said that the Lake street L drew only from the horse lines, which were the least productive at any time. He believed the west side would earn 9 per cent in 1894. The passengers carried were 107,053,461. Of the stock 90,000 shares were represented. The prospects for the tunnel at Van Buren street were, that it would largely increase traffic at that point and be in operation within two months.

## NORTH CHICAGO STREET RAILROAD COMPANY.

January 9, Mr. Yerkes stood before 39,306 shares of stock of the North Chicago Street Railroad Company and rendered them the account of the stewardship, and it was a good record. The tabulation is somewhat as follows:

## RECEIPTS.

Total passenger receipts,	- - -	\$3,014,789.50
From other sources,	- - -	86,358.75
Total,	- - -	\$3,101,148.45

## DISBURSEMENTS

Current operating expenses,	-	\$1,412,755.80
Railroad rentals, taxes, insurance, etc.,	533,874.63	
Total,	- - -	\$1,946,630.43
Net earnings,	- - -	1,154,509.82
Dividends,	- - -	618,574.50
Credit balance January 1, 1894,	-	1,264,344.56

The passengers carried were 50,419,457, an increase of 9,892,216 over last year. It costs 1.788 cent per passenger on the cable lines and 3.414 cents on the horse lines. The percentage of operating expenses to gross receipts were 45.55, an excellent record.

## THE LAKE STREET L.

Ninety-one thousand six hundred of the 100,000 shares of Lake Street L stock were represented at the annual meeting January 9. President Roche read his annual report. The reason for the Madison street terminal on Market street was given as the best available place, and the branch line ordinances explained as meaning two branches to the north and north-western parts of the city. The new structure to West Forty-fourth street has its work carried forward, and iron is distributed to Fifty-second street, so that by April, 1891, the line will be

operated to that point. On the line operated from Madison street to Hamlin avenue 30,000 people are carried per day, paying all operating expenses, with a balance in the bank. The report was adopted.

## FROM A MASTER.

At the annual meeting of the North Chicago Railroad Company, Mr. Yerkes spoke very freely on a few topics of interest to every manager, and coming from that master of the craft, authoritative. Mr. Yerkes said:

"I do not think that any elevated railroad which will be built on the North side will hurt the business of our system. Though the total business of December and that of the first eight days of this month was less than the corresponding periods a year ago, yet the operating expenses have been reduced more than enough to offset it, so that the net income is larger than it was. In operating a business like ours nothing that you can do will increase the income very much; that practically takes care of itself. But the operating expenses are all in our own hands. We are constantly making improvements that materially reduce these expenses. We keep gaining experience and dexterity. For instance, in the mere matter of grip shoes we have made such improvements that whereas formerly a grip shoe lasted only an average of a day they now last an average of two or three weeks. Of course we have not made corresponding improvements in everything, but we are constantly making improvements somewhere. This applies, however, in the main only to the part of our system operated by cable. We can't reduce expenses much on the horse-car lines."

Mr. Yerkes believes in inducing pleasure riding, as is evidenced by the right given the directors to improve the attractions of Lincoln park by several expensive additions.

A LA CROSSE impediment to traffic lately, was a thick coating of ice on the trolley wire. To overcome this trouble, a motor car with the trolley wheel pressing the wire was pushed forward by another car. The first trolley cut the ice so that the following car could get a contact. The fight was kept up nearly all day, with the odds in favor of the storm. Vaseline must be dear in La Crosse.

A CHATTANOOGA cigar firm advertises a free cigar to every conductor and motorman who will call for it, the object is, of course, to have the men talk the special brand to passengers. It might be suggested that an advertisement in the cars would pay the company better.

THE reorganization of the National Electric Company, of Eau Claire, Wis., has been effected. A. L. Ide, of Springfield, Ill., takes the presidency; Peter Truax, of Eau Claire, vice-president; William A. Rust, treasurer. The paid up capital of the new company is \$50,000.

FRANCIS STEWART, the oldest street car driver of Hartford, died January 3. He was 75 years of age, and a motorman at the time of his death. He drove the first Hartford horse car, and has been an employe in transportation lines for fifty years.

THE Tacoma Railway & Motor Company says it built fifteen electric cars in 1893.



## NEWS FROM THE CITIES.

### American Street Railway Association.

HENRY C. PAYNE, PRESIDENT, Milwaukee, Wis.  
 WM. J. RICHARDSON, SECRETARY AND TREASURER, Brooklyn, N. Y.  
 W. J. STEPHENSON, FIRST VICE-PRESIDENT, Washington, D. C.  
 J. R. CHAPMAN, SECOND VICE-PRESIDENT, Grand Rapids, Mich.  
 LEWIS PERRINE, THIRD VICE-PRESIDENT, Trenton, N. J.  
 EXECUTIVE COMMITTEE: D. F. LONGSTREET, Denver, Col.; T. H. McLEAN, Indianapolis, Ind.; ED. WHITTAKER; W. Y. SOPER, Ottawa, Ont.; and E. S. GOODRICH, Hartford, Conn.  
 Place of next meeting, Atlanta, Georgia, third Wednesday in October, 1894.

### Massachusetts Street Railway Association.

President, J. H. CUNNINGHAM, Boston; First Vice-president, AMOS F. BREED, Lynn; Second Vice-president, FRANK S. STEVENS, Fall River; Third Vice-president, SAMUEL WINSLOW, Worcester; Secretary and Treasurer, A. E. BUTLER, Lawrence. Executive Committee, A. A. GLASIER, Boston; E. C. FOSTER, Lydd; CHAS. ODELL, Salem; P. F. SULLIVAN, Lowell; E. P. SHAW, Newburyport; PRENTISS CUMMINGS, Boston; R. S. GOFF, Fall River.  
 Regular meetings first Thursday of each month.

### Maine Street Railway Association.

President, WILLIAM R. WOOD, Portland.  
 Secretary and treasurer, E. A. NEWMAN, Portland.  
 Next meeting will be held the first Wednesday in February, 1894.

### Ohio State Tramway Association.

President A. E. LANG, Toledo; Vice-president, W. J. KELLY, Columbus; Secretary and Treasurer, J. B. HANNA, Cleveland; Chairman Executive Committee, W. A. LYNCH, Canton, O.  
 Meets at Toledo on the fourth Wednesday in September, 1894.

### The Street Railway Association of the State of New Jersey.

President, JOHN H. BONN, Hoboken; Vice-president, THOS. C. BAER, Newark, Secretary and Treasurer, CHARLES Y. BAMFORD, Trenton; Executive Committee, OFFICERS and C. B. THURSTON, Jersey City; H. ROMAINE, Paterson; LEWIS PERRINE, JR., Trenton.

### The Street Railway Association of the State of New York.

D. B. HASBROUCK, PRESIDENT, New York City.  
 O. TRACY ROGERS, FIRST VICE-PRESIDENT, Binghamton.  
 JAS. H. MOFFATT, SECOND VICE-PRESIDENT, Syracuse.  
 WILLIAM J. RICHARDSON, SECRETARY AND TREASURER, Brooklyn.  
 The next meeting will be held at Syracuse, on the third Tuesday in September 1894.

### Pennsylvania Street Railway Association.

H. R. RHOADS, PRESIDENT, Williamsport.  
 R. L. JONES, FIRST VICE-PRESIDENT, Reading.  
 S. P. LIGHT, SECRETARY, Lebanon.  
 WM. H. LANIUS, TREASURER, York.  
 Next meeting at Reading first Wednesday, in September, 1894.

### Arizona.

PHOENIX, ARIZ.—Geo. W. Hoadley has been appointed receiver of the Phoenix Electric Light & Power Company. Reorganization is to be made.

TUCSON, ARIZ.—Ten miles of narrow gauge rail for the Tucson, Globe & Northern Railway, now abandoned, has been sold to the Los Angeles Consolidated Electric Railway Company.

### Arkansas.

LITTLE ROCK, ARK.—The Thomson-Houston attachment suit against the Little Rock street railway has begun. It involves the legality of claims aggregating \$300,000. The company is now in receivers' hands.

HOT SPRINGS, ARK.—Col. Fordyce says that the street railway extensions will be made as soon as material is purchased.

The Hot Springs Incline Railway & Casino Company has gained right of way for construction of inclined railway on West Mountain. Ex-Senator Geo. W. Baxter, John D. Ware, Leslie Webb, get the grant. Work to be completed July 1, 1894.

### California.

POMONA, CAL.—C. G. Baldwin says, that C. W. Foote, of Cleveland, is back of his scheme for the Claremont road, and that it will be built at once if the proper subscriptions are made.

POMONA, CAL.—The bids for the franchise for the electric road to Claremont have been opened. C. G. Baldwin, the only bidder, received the award for \$1.

SAN FRANCISCO, CAL.—H. E. Huntington succeeds to Leland Stanford's place on the Central Pacific Railway directorate. Mr. Huntington's election will not affect street railway affairs in Frisco.

OAKLAND, CAL.—President Meyers, of the Alameda, Oakland & Piedmont Electric Railway, says that the improvements that will be made before April 1 will cost \$100,000.

LOS ANGELES, CAL.—T. D. Hoskins withdraws his petition for franchise, in order to amend it.

SAN DIEGO, CAL.—Dwight Braman is proceeding with the organization of his rival railway. Ralph Granger, J. M. Hill et al, are on his papers and the organizers think that the line will go.

SACRAMENTO, CAL.—G. P. Kingsbury, superintendent of the Central electric system, under the new management, says that the construction and improvement contemplated will all be finished by February 1. Service will be materially enlarged.

LOS ANGELES, CAL.—W. J. Brodrick has gained franchise for a cross town electric line, which will be immediately prosecuted.

LOS ANGELES, CAL.—The Redondo Railway Company has filed its petition for a franchise in the city, to run fifty years.

### Canada

WOODSTOCK, ONT.—Application is made for a charter for the Woodstock Street Railway, by Geo. P. Patullo, J. M. Grant, John White, D. W. Carn and R. Ball. It is the intention of the company to use the Niagara Falls power.

TORONTO, CANADA.—The Street Railway Company will increase its horse-power by 3,000, and build new power house.

TORONTO, CAN.—The Toronto Street Railway will buy additional power equipment.

NIAGARA FALLS, ONT.—Hamilton, Grimsby & Beamville electric road is about to be connected with the Niagara Falls, River and Park line. Some supplies already bought. To be operated next July.

VANCOUVER, B. C.—D. Openheimer, of this place, takes party of capitalists over electric line. F. Nicholls, of the Canadian General Electric, and H. P. Dwight, of the Western Union Telegraph, were among the number.

WINNEPEG, MANITOBA.—A company is said to be organized to build a street railway from Rat Portage to Keewatin.

### Chicago.

CHICAGO.—The Central Construction Company, which is to build an elevated down town loop for the connection of all L roads, organizes thus: E. S. Pike, O. F. Aldis, E. K. Butler, W. E. Hale, C. N. Fay, B. A. Eckhart, and H. P. Hurd. The directors at once elected Mr. Hale president, C. N. Fay, vice-president, and Byron L. Smith, treasurer. The road will be built for cash, and the stock will not be watered.

CHICAGO.—The Lake View Transit Association has formed; officered as follows: Wm. Grace, president; J. L. Flannery, vice-president; J. E. Tilt, secretary; John McConnell, treasurer. They represent property holders, owning on Evanston avenue, between Diversey street and Lawrence avenue.

CHICAGO.—D. H. Louderback, the Rookery, president of the Chicago North Shore Electric, and Samuel Insull, president of the Chicago Edison Company, are prime movers in an extensive system of electric railways for the North and North-west Sides.

CHICAGO.—The mayor's amendments are adopted and the North-western L ordinance is passed as amended. This is the third consideration and is said to be acceptable to both parties.

CHICAGO.—Another report from the Alley L officials, says investigations as to the feasibility of electric power are being made. The Alley L minority stockholders fail to get control of the board.

Mayor Hopkins vetoes Northwestern Elevated franchise, but recommends amendments that will probably be agreed on.

CHICAGO, ILL.—The ordinance for the Northwestern Elevated Railroad passed the council. This is the first of the numerous North Side "L" ordinances to pass council. The directors are, as before announced: Edward W. Russell, Chicago; Walter M. Anthony, Evanston; Bion J. Arnold, Chicago; Harold Sturgess, Chicago; Frederick Sargent, La Grange, Ill.

CHICAGO.—The Chicago Suburban Rapid Transit Company is incorporated at \$500,000, by W. E. Gehring, 111 Monroe street; E. G. Henkel, 138 Loomis street, both stenographers, and C. A. Jackson, 1605 Ashland Block, and L. E. Sauter, R. 607, 84 La Salle street, lawyers. The road will connect DuPage and Cook counties.

CHICAGO.—The North Chicago Railroad Company reports increase of \$493,277 over last year, at increase of expense of \$78,703. Left for fixed charges, dividends and surplus to income account, \$1,602,133.

The West Chicago earned \$5,235,623, at an expense of \$2,892,982. Mr. Yerks reports that Lake Street L competition has not hurt the cable lines, drawing only from the horse lines.

### Colorado.

FLORENCE, COL.—Ex-Senator J. A. McCandless revives the Florence & Cripple Creek Electric Power & Light Company. It will soon begin active work on the railroad.

### Connecticut.

WEST HAVEN, CONN.—The West Shore Railway Company, of which Israel A. Kelsey is secretary and manager, will begin to build March 1. It is a cross country road, and has bought no supplies as yet.

WALLINGFORD, CONN.—The Meriden Street Railway will be extended to this place, and a pleasure resort of considerable prominence located here.

HARTFORD, CONN.—W. H. Goodrich, W. H. Bulkeley, of the Hartford & Middleton; David Henney, P. H. Quinn, of the Windsor & Suffield; W. H. Bulkeley and P. H. Quinn, of the Hartford Suburban, all recently incorporated lines, it is said will consolidate and equip electrically, making a large electric system.

HARTFORD, CONN.—The Hartford & West Hartford Electric Railroad Company, David Henney, president; W. E. Goodwin, secretary, has let contract for its two new lines.

### District of Columbia.

GEORGETOWN, D. C.—W. N. Lynch, W. M. Elleson, John Hammond, M. E. Church and J. C. De Putron are leaders in a determined effort to build a line from Falls Church to Washington.

WASHINGTON, D. C.—An electric railway between Marlboro and the District is contemplated in a new bill before the house.

### Florida.

TAMPA, FLA.—T. C. Taliafero has been appointed receiver of the Tampa Street Railway & Power Company.

### Georgia.

ATLANTA, GA.—Consolidated Street Railway Company defaults its January interest on bonds. The bondholders agree not to ask for receiver if the stockholders will pay \$17 a share and raise floating debt.

### Illinois.

LA SALLE, ILL.—The Interurban Electric Railway is organized at \$250,000, by C. W. Palmer, R. W. Gardner and M. C. Van Vleet.

ALTON, ILL.—General Manager J. F. Porter, of the Alton Electric Railway, is making estimates for a North Alton line, and says it will be built early in the spring. No material bought yet.

PEORIA, ILL.—The Central Railway Company has announced that employes will, hereafter, be required to work fifteen instead of twelve hours. Pay to remain the same.

PEORIA, ILL.—The Peoria Terminal Railway people contemplate building a bridge across the Illinois river. It is said that it will also accommodate the new Peoria-Pekin Electric Railway line. It is claimed that no action of congress is necessary to gain rights.

BELLEVILLE, ILL.—Belleville Steel Company will resume operations.

BELLEVILLE, ILL.—Belleville Electric Railway incorporated, capital, \$300,000. Messrs. J. H. Atterbury and John W. Griswold, Litchfield, Ill.; Paul W. Abt and R. Ross, East St. Louis; and John J. McLean, Hillsboro, Ill., incorporators. The object of the company is to construct an electric railway from the eastern limits of Belleville to the western limits of East St. Louis.

QUINCY, ILL.—President W. S. Warfield, says that the extensions on the Quincy Electric Railway will not be built until the fifth year of the time allowed.

ROCKFORD, ILL.—The Rockford Street Railway Company elects officers: Judge Baylies, president; H. W. Price, vice-president; Mr. Maxham, secretary.

WAUKEGAN, ILL.—Waukegan Electric Railway Company petitions for an extensive franchise in the town of Waukegan.

### Indiana.

INDIANAPOLIS, IND.—A. A. Anderson assumes the management of the Youngstown, O., road.

TERRE HAUTE, IND.—R. B. Harrison has issued attachment at New York against the American Casualty & Insurance Company, for \$1,000.

INDIANAPOLIS, IND.—The street car Brotherhood has voluntarily surrendered its charter to the National Federation, and is declared locally defunct.

ELWOOD, IND.—Citizens of Elwood, Frankton and Logansport are endeavoring to connect the towns named with an electric railway. A preliminary meeting has been held.

MUNCIE, IND.—The Muncie electrical works are placed in J. N. Cropper's hands as receiver, in order to adjust partnership difficulty.

BRAZIL, IND.—Brazil Rapid Transit Company elects R. N. Bayless, president; John D. Sourwine, vice-president; G. Van Ginkle, secretary.

### Iowa.

COUNCIL BLUFFS, IA.—The franchise of the Omaha & Council Bluffs Bridge & Railway Company in this city, was declared forfeited by Judge McGeo, of the superior court,—the result of a 5-cent fare fight.

OTTUMWA, IA.—Superintendent F. Wayland Brown, of Youngstown O., is said to be the accepted manager of the railway and light plant here.

KEOKUK, IA.—Judge Bank, of the Superior Court, has appointed H. C. Reiner receiver for the Gate City Electric Street Railway, on application of the Central Trust Company, New York.

TOLEDO, IA.—The Toledo-Tama Electric Railway is being revived, by L. H. Ong, of New Sharon, Ia., and L. B. Bradley, of Peoria, Ill., who have secured the franchise. The new owners of the franchise will put up a forfeit.

COUNCIL BLUFFS, IA.—L. C. Besley, Alex Wood, H. G. McGee, et al., form association for fighting the motor company, and promoting a new company, to run in the first ward.

SIoux CITY, IA.—The Consolidated Street Railway was organized here by John Pierce, A. E. Pierce, P. and C. Moller and H. A. Johns. It absorbs the Sioux City Cable. All Lines will now be united therewith, namely: the Sioux City Street railway, the Rapid Transit lines, Riverside Electric and Sioux City and Leeds Electric—into one electric system with forty-five miles of lines. Company is capitalized at \$1,000,000 with New York and Sioux City offices. The incorporators deed \$1,200,000 worth of property to the Company.

BURLINGTON, IA.—Geo. O. Ray, and others, have their franchise for a new electric railway, admitted to a full reading in the council. The company must begin construction within six months.

DAVENPORT, IA.—W. E. Davis, an electrician, has a scheme for an electric railway from Davenport to Clinton, using the Mississippi river as power.

SIoux CITY, IA.—The Consolidated Street Railway Company elects John Pierce, president; A. L. Pierce, vice-president; Pehr Moller, secretary and treasurer.

INDEPENDENCE, IA.—C. W. Williams, the horse man, executes deed of trust to R. Campbell for \$106,600, of which the Independence Electric Railway is considered \$35,000.

## Kansas.

LEAVENWORTH, KAN.—Receiver Erb and the city council have come to an agreement on an ordinance, and the change to electricity will probably be made.

LEAVENWORTH, KAN.—Citizens' committee, headed by Hon. A. Caldwell, et al., will assist Newman Erb in getting a rapid transit franchise.

WICHITA, KAN.—J. W. O'Neil and Fred W. Sweet, of this place, have received word that their street railway franchise at Perry, Okla., has been granted.

## Kentucky.

LOUISVILLE, KY.—It is fully determined to abandon the Daisy Electric service, substituting steam on the K. & I. bridge.

LOUISVILLE, KY.—Frank A. Hodges has been appointed general electrician for the Kentucky & Indiana Bridge Company.

LOUISVILLE, KY.—Receiver John McCloud, of the K. & I. Bridge Company, files his report that gross earnings between October 14 and December 22, 1893, \$2,721.04 net \$190.98.

## Louisiana.

NEW ORLEANS, LA.—There is a rumor that the Traction Company will buy the St. Charles Street Railway.

## Maine.

BATH, ME.—Charles Gahan has been made superintendent to succeed W. B. Hayden of the Bath Street Railway.

## Maryland.

BALTIMORE, MD.—The Baltimore & Washington Turnpike & Tramway Company, to build between Baltimore and Washington, has organized with the following board of directors: David M. Newbold, President; Robert T. Carswell, Charles B. Calvert, John J. Dobler, William L. Elkins, Peter B. Widener, Thomas Delan, T. Edward Hambleton and Howard Munnikhuyzen.

TOWSON, MD.—The Pikesville, Reisterstown & Emory Grove Railway Company file articles of incorporation at Towson, through George R. Webb, John Cowan, Oscar T. Crosby, Thomas J. Elliott, Reister Russell and Richard H. Cox, incorporators.

BALTIMORE, MD.—E. Pratt, F. C. Latrobe and Robert Bennert, trustees to the Wenstrom Electric Company, have taken rights, property and franchises of the Wenstrom Consolidated Dynamo & Motor Company.

## Massachusetts.

FALL RIVER, MASS.—The Fall River & Stone Bridge Electric Railway Company in Tiverton, elects the following officers: President, D. P. Church, of Tiverton; Corporation clerk, M. G. B. Swift, of Fall River; Treasurer, N. B. Church, of Tiverton; Directors, D. P. Church and N. B. Church, Tiverton; George W. Slade, Weaver Osborn, M. G. B. Swift, Robert Goff, Fall River; Frank S. Stevens, Swanzey. The company is capitalized at \$100,000 and the work will begin shortly.

WORCESTER, MASS.—The Worcester Consolidated elects as directors: C. B. Pratt, A. G. Bulluck, F. H. Dewey, of Worcester; E. J. Moore, Philadelphia; and T. C. Barr, of New York. Mr. Pratt is made president; A. H. Stone, secretary.

WORCESTER, MASS.—The North End Street Railway will not appoint a man to succeed Superintendent West. Electrician Townsend will do duty as superintendent.

BROCKTON, MASS.—A scheme is on foot to consolidate all the street railways in Brockton. Seven suburban lines, Bridgewater, Holbrook, Whitman, Stoughton, East Side, East Bridgewater, are in process of changing charter. The Brockton Street Railway asks to amend charter, to increase capital, and lease and operate. Electrical extensions are contemplated.

NEW BEDFORD, MASS.—The Union Street Railway Company asks permission of the State Railroad Commission to increase capital stock \$240,000 and issue \$500,000 first mortgage bonds.

NEW BEDFORD, MASS.—Chas. S. Mendall is appointed superintendent of the New Bedford division of the Union Street Railway.

BOSTON, MASS.—A Lewiston, Me., dispatch to the Boston Herald, says that Hon. Frank Jones and Arthur Sewall are forming company to build, from Portland, Me., to Boston, an electric railway.

## Michigan.

ST. JOSEPH, MICH.—L. O. Ives and Wm. Ottman, of Chicago, who have gained franchise for electric railway recently, are here making arrangements for the road and real estate investment.

SAGINAW, MICH.—The Union Street Railway Company will extend its lines two miles up the river in the spring, and open up a pleasure resort of 100 acres.

DETROIT, MICH.—Chas. C. Cadman et al, of Detroit, claim that they represent English capital, and want a franchise for a street railway. They have already optioned a factory to be used as a plant and have deposited \$10,000 guaranty. Thirty-year lease asked.

DETROIT, MICH.—Col. J. M. Clark is at the head of the new company, which will build a street railway line from Windsor to Sandwich, Ont. The incorporation will be made at the next session of the Ontario legislature. Some of those interested in the scheme besides Col. Clark, are: William McGregor, M. P.; J. D. Bourke and Thomas Ouellette, of Windsor; Mayor Mullen, W. D. Ballour, M. P., and John A. Auld, of Amherstburg. The new line will be called the Detroit, Windsor & Amherstburg Railway.

MUSKOGON, MICH.—G. P. Kingsbury, formerly general superintendent of the street railway system here, will take management of the Sacramento, California, system on February 1.

DETROIT, MICH.—Mayor Pingree says, that he has a syndicate behind him that stands ready with \$10,000,000, to take up purchase of the street railways.

ISHPEMING, MICH.—A. B. Miner is elected secretary of the Ishpeming & Negaunee Street Railway Company, vice E. R. Hall, resigned.

BATTLE CREEK, MICH.—Edward C. Hinman, of Battle Creek, has been appointed receiver of the Battle Creek Electric Railway Company under bond of \$15,000.

ISHPEMING, MICH.—The Ishpeming and Negaunee Street Railway Company has suspended operations for the winter. Heavy storms and light business is the cause alleged.

BATTLE CREEK, MICH.—Edward C. Hinman, receiver of the Battle Creek Railway, says that he will attempt to put the road in good shape and improve the service.

## Minnesota.

MINNEAPOLIS, MINN.—The labor commissioners will enforce the adjustment of vestibules to all street cars.

ST. PAUL, MINN.—H. M. Bylesby is elected president and general manager, vice W. S. Morton, resigned, and H. C. Lewis is elected vice-president of the St. Paul & White Bear Electric Railway.

DULUTH, MINN.—The new machinery for the incline at Seventh street is about ready for action, and a winter resort business is being done. Allis engines, Walker drums, and Roebing Wire Rope Company's ropes are used.

DULUTH, MINN.—The City Council has granted franchise to the City Railway Company recently organized.

ST. PAUL, MINN.—The Williams General Manufacturing Company has been incorporated at \$10,000,000 to build motors and the Dent telegraph type writer. D. H. Dent, of St. Paul Park, is president, F. M. Johnson, secretary, both of St. Paul.

DULUTH, MINN.—The council passes ordinance requiring transfers, and strikes out 7 per cent grade requirement, on the strength of the experience of other cities.

### Missouri.

KANSAS CITY, MO.—The West Port city council will pass ordinance allowing the Kansas City Electric Company to run a street railway line down Main street in West Port, to make valuable connections.

KANSAS CITY, MO.—The Merriam Park, Rosedale & Kansas City Electric Railway elects A. A. Pearson, president; B. F. Hollenbeck, vice-president; S. W. Brown, treasurer; and T. J. Wilson, secretary. The line will be six and one-half miles long.

KANSAS CITY, MO.—Robt. Gillam, representing bond holders of the Northeast Electric Railway Company, says that the company will pave next spring.

ST. LOUIS, MO.—The National Unicycle Electric Railway Company, through Councilman Anderson, introduces request for franchise throughout the city. The promoters are, J. L. LaPrelle, E. F. Williams, Oscar Reid, H. Daughaday, D. W. Caruth, J. O. Talbot, Geo. L. VanBeek, J. J. Worshave and a dozen others. Usual conditions and tax of \$3,000 a year to city are volunteered in exchange for rights.

SEDALIA, MO.—Superintendent Carroll, of the Electric Light Railway plant, suffered the wrecking of one of his engines.

ST. LOUIS, MO.—J. D. Houseman, John Pitman, Jeremiah Fruin, Geo. L. Edwards, et al., have been granted fifty years franchise in Kirkwood for the Merrimac Highlands Electric.

ST. LOUIS, MO.—County Court grants the St. Louis, Kirkwood & Merimac River Electric Railway until April 20, 1894, to deposit \$5,000 guarantee to fulfill conditions to work franchise of railway granted some time since.

KANSAS CITY, MO.—C. E. Moss and Robert Gillam have secured consents for proposed extension of the L electric road. Work begins in March.

KANSAS CITY, MO.—Merriam Park, Rosedale and Kansas City Electric Railway is organized at \$50,000 by A. A. Pearson, E. G. Bartherger, Dr. J. C. F. Maloney, B. F. Hollenbeck, T. J. Wilson, John R. Foster, George Branham, D. R. Mattney and C. W. Brown.

KANSAS CITY, MO.—Franchise is granted W. W. Kendall and Theo. S. Case, by the Westport city council, for electric line, to connect cable line and the suburb. Hugh T. McElroy and Preston Roberts are directors, and the grant is for twenty years.

### Montana.

BUTTE, MONTANA.—The Butte Street Railway is refused its petition to suspend operations until next May.

### Nebraska.

GRAND ISLAND, NEB.—A. H. Baker, president, gives bill of sale for all personal property of the Street Railway Company to A. W. Ockahock, of Portland, Ore. Consideration was \$11,333. Instrument covers all rolling stock, horses, etc. Superintendent Lamon is in charge.

BEATRICE, NEB.—The United States Circuit Court is trying to settle the troubles arising from the failure of the Beatrice Rapid Transit Company.

### New Hampshire.

LAONIA, N. H.—It is rumored that the Lakeport & Laconia Street Railway will be sold to Philadelphia capitalists, and changed to electric.

EXETER, N. H.—Hon. E. G. Eastman is leader of the Electric Railway scheme which is now being brought to a point of operation.

### New Jersey.

TRENTON, N. J.—The New Jersey Railway Company, incorporated recently, makes known its plan. The scheme is to build an electric road from New York to Philadelphia. Power stations will be located at Philadelphia, Trenton, Bound Brook, Elizabeth, and other points. E. Chamberlain, builder of the Port Reading railroad, is the engineer. Joseph H. Reall, of Bloomfield, is the projector of the enterprise, and associated with him are Charles E. W. Smith, of Morristown; J. H. Baldwin, of Orange; George S. Forbush, of Boston, and Major John Runk. It is given out that the Pennsylvania railroad is back of the enterprise, and that the franchises have been secured.

NEWARK, N. J.—Suburban Traction Company has executed all contracts for equipment electrically. Robin's safety fender and Brill cars adopted.

BRIDGETON, N. J.—The West Side Railway recently organized, elects William Welsh, Jr., Philadelphia, president; J. Pemberton Newbold, Philadelphia, vice-president; Walter H. Bacon, Bridgeton, secretary and treasurer.

The Bridgeton, Cedarville & Port Norris is incorporated by Osgood Welsh, New York; Richard W. Clay, Philadelphia; Charles R. Newbold, Thomas U. Harris, William O. Garrison, and John Smalley, Bridgeton.

HOBOKEN, N. J.—The Fort Lee, Leonia & Hackensack Electric Railway has been placed in receiver's hands by chancellor McGill. It is said the company owes \$9,000, mainly in labor. Its assets consists of real estate.

NEWARK, N. J.—The line between Newark and Jersey City is now in efficient operation.

### New York.

NEW YORK CITY.—The Jarvis-Conklin syndicate will soon be rehabilitated. The capital stock will be reduced from \$3,750,000 to \$2,500,000. All liabilities will be merged into one series of debenture certificates bearing 4 per cent.

SANBORN, N. Y.—The citizens of Sanborn raise money to procure extension of the Buffalo & Tonawanda Electric Railway to this place.

BROOKLYN, N. Y.—Brooklyn City will equip all cars with safety fenders.

NEW YORK CITY.—The Twenty-ninth Street Railway Company has been sold under foreclosure, to F. C. Linde, for \$50,689.

PORT JARVIS, N. Y.—A. T. Perry, T. J. Fallon, et al, of Port Jarvis, as a citizen's committee, recommend that the Port Jarvis & Suburban Street Railway, be given rights to build electric railway system in Port Jarvis.

NEW YORK CITY.—Broadway Railway Company consolidating articles gives additional mileage and another name. Those consolidated are the Houston & West Street and the South Ferries Company. Metropolitan Railway Company is the new name. H. H. Vreeland is, of course, president.

AMSTERDAM, N. Y.—Amsterdam Street Railway Company re-elects old board of directors.

BROOKLYN, N. Y.—A committee, consisting of H. B. Hollins, H. Seligman, D. F. Lewis, and S. L. Keeney, decide on consolidation of Long Island Traction Company and the Broadway Railroad Company, of Brooklyn.

GLEN FALLS, N. Y.—A. S. Crabel retires from the superintendency of the Glen Falls & Ft. Edwards electric line. The capital stock of the road has been increased from \$120,000 to \$150,000. A second mortgage has been placed for \$50,000.

NEW YORK CITY.—A bridge across the Kill von Kull from New Jersey to Staten Island is to be built by the Consolidated Traction Company. John D. Crimmins, of New York, represents the builders, and much heavy capital is interested.

ROCHESTER, N. Y.—O. W. Powell, it is said, will build one mile of electric railway to be in operation before July 1.

SYRACUSE, N. Y.—The old Steam, Heat & Power Company, already owning extensive boiler plant, are in the field to compete for furnishing electric power, and perhaps street railway power. The existing company will fight the franchise

NEW YORK CITY.—The Metropolitan Street Railway Company capitalizes at \$8,200,000 and elects H. H. Vreeland, president; D. B. Hasbrouck, vice-president; Hans S. Beattie, treasurer, and C. E. Warren, secretary.

GLOVERSVILLE, N. Y.—The Gloversville Electric Railway and the Cayadutta Electric Railway have consolidated and capitalized at \$350,000.

NEW YORK CITY.—Charles R. Henderson, president of the United States Trust Company, has been elected president of the Metropolitan Traction Company.

TROY, N. Y.—The Gilbert Car Works having finished all contracts have shut down indefinitely until reorganization.

BROOKLYN, N. Y.—The Brooklyn City Railway has some large extensions in mind.

## Ohio.

TIFFIN, O.—The recent decision of the supreme court encourages the Electric Railway & Power Company to put in third rail, relay one rail of the Tiffin Street Railway track, and run its cars over the latter's right of way. Fine points of the law are involved, and a hearing is set for January 27.

TOLEDO, O.—Toledo and Maumee Valley Railroad Company organized to build extensive electric railway system. Capitalized at \$300,000 by W. B. Taylor, Josiah D. Cook, Geo. G. Metzger, Parks Foster and Grant Williams. Principal offices at Toledo. King and Tracy, solicitors.

CLEVELAND, O.—Ohio Construction Company assigns to B. M. Barr. It was incorporated at \$10,000. The assets are \$3,000, and liabilities \$5,500.

SANDUSKY, O.—Receiver J. C. Gilchrist, of the Sandusky, Milan & Norwalk Street Railway, has been discharged.

MIDDLETOWN, O.—Middletown & Madison Street Railway Company is appraised at \$13,507, and Receiver Bundy so notified. One and-a-half miles of track, six cars, all horses and real estate included in estimate.

PORTSMOUTH, O.—The city council have turned the city lighting contract over to the street railway.

TIFFIN, O.—The incorporators of the Tiffin Interurban, as the new road is called, are: Thomas B. Williams, New York City; Charles F. Shaw, New Bedford, Mass.; F. W. Brightman, Fall River, Mass.; Nelson W. Miller, Meshech Frost, Amandus Betts and Rollo W. Brown, Tiffin, and Dr. Rosendale, Fostoria.

FREMONT, O.—Jas. H. Hunt, solicitor, and Louis Gormley, of the Fremont city council, are working at framing a franchise for change of power on the Fremont horse railway.

TOLEDO, O.—The Maumee city council has extended the franchise granted T. B. Brown, John Kumlner and Coleman Keeler. J. K. Tillotson holds the franchise and interest and says that the road will be built next season.

CLEVELAND, O.—Report is generally believed that the Walker Manufacturing Company plant will be turned into an electric railway factory. Bentley and Knight are said to be concerned in the deal, and the combination will be a strong one.

HAMILTON, OHIO.—D. B. Bundy is appointed receiver for the Middletown & Madison Street Railway Company on petition of S. Margrum, trustee.

TIFFIN, O.—The Consolidated promoters will build a line from Tiffin to Melrose and Sycamore, and have increased capital to \$400,000 to raise the money. They will incorporate in a few days. The Tiffin-Fostoria line will operate next spring.

LIMA, O.—Extensive improvements and additions are outlined for the Lima Street Railway during the coming season. Superintendent W. H. Thompson, resigns, to take effect February 1, and will be succeeded by H. M. Ingold, a brother-in-law of the president. Mr. Ingold comes from Pittsburg.

NORWALK, O.—Sandusky, Milan & Norwalk Electric, elects Geo. H. DeWitt, president, and W. E. Gilcher, S. E. Crawford, T. B. Taylor and J. D. Parker, as a committee to take charge of affairs, buy supplies and act as superintendent. The line is to be extended early in the spring.

ZANESVILLE, O.—Messrs. Chapman and F. A. Sieberling, of Akron, Ohio, are prime movers in the street railway and light proposition for Zanesville and claim that active business will begin soon. A big power plant will be built.

COLUMBUS, O.—Columbus & Clintonville Electric Railway and the Worthington lines, are said to be about to consolidate.

DAYTON, O.—The City Railway, a combination of the former lines, asks stockholders to vote on a proposition for \$600,000, 6 per cent bonds, which sum is to be used in equipping it with electricity; Wm H. Simms is secretary.

COLUMBUS, O.—Tiffin, Fostoria & Norwalk electric railway organized at \$300,000 by Thomas B. Williams; Charles F. Shaw, N. W. Miller, M. Frost, A. Betts, R. W. Brown and T. R. Rosendale.

WOOSTER, O.—The city council takes action, instructing the city solicitor to forfeit the \$5,000 bond given by O. H. Barr, of Cleveland, to secure a street railway franchise in the town.

NORWALK, O.—Treasurer A. W. Prout, of the Sandusky, Milan & Norwalk Electric Railway, has sold eighty-three shares of stock at \$50. This is the remaining stock, and the work of construction will now go on smoothly.

NORWALK, O.—J. H. Stewart, of the Lake Erie Engineering Company, from Sandusky, has been here looking up possibilities for an electric railway in the southern part of the county. Attorney J. H. Williamson is the local enthusiast and promoter.

NILES, O.—Superintendent Honecker resigns and is succeeded by Mr. Donnell.

## Oklahoma.

PERRY, OKLA.—G. E. Clafin, of Kansas City, has gained an electric light franchise at Perry.

## Oregon.

PORTLAND, OREGON.—It is said by men who ought to know, that the General Electric Company, of Portland, is about to build new lines and extend old ones, until a continuous electric road is finished, via Oregon City to Astoria. Water power is to be used, and freight is to be carried principally. The Southern Pacific has the money that backs the scheme.

East Side Street Railway goes to Jos. Simons, as receiver. Creditors: Northwest General Electric, German Loan & Savings Association, of San Francisco.

## Pennsylvania.

McKEESPORT, PA.—The Dravosburg Electric Street Railway Company will build immediately four and one-half miles of railway. The company is capitalized at \$27,000, and the officers are: Herman Laub, of Pittsburg, president; directors, Ira J. Wilson, James P. Wilson, of Pittsburg, and Homer H. Swaney, of McKeesport. This line, it is asserted, will connect with the Second Avenue, Pittsburg, line at Homestead, making a continuous electric line from McKeesport to Pittsburg. The latter road will cross the river by a bridge to be built by the Glenwood Highway Bridge Company at or near Glenwood, in order to get into Homestead.

NEW CASTLE, PA.—The planing mill and machinery of the New Castle Car Manufacturing Company were destroyed by fire December 21, but will be immediately rebuilt and operating within thirty days. They are in the market for a new engine and machinery equipment. F. A. Hoyer is the manager, and will receive bids.

PITTSBURG, PA.—The Braddock street railway is about to be revived, the road supervisors agreeing to the demands of the line.

PITTSBURG, PA.—Pittsburg Elevated Railway Company is chartered at \$100,000, to build a ten mile line from Pittsburg to Wilkensburg. John H. Dalzell is President. The directors are Joshua Rhodes, W. B. Rhodes, G. B. Hill, J. D. Nicholson, R. S. Frazer and A. M. Neeper. The Northside Elevated Railroad Company, capital, \$50,000, was also chartered with Mr. Dalzell, president, and G. B. Hill and Joshua Rhodes directors.

POTTSTOWN, PA.—The Pottstown, Boyertown & Reading Electric Railway has let its contract for the line between the first named place at \$100,000 for the seven miles. The officers of the company are: President, James B. Craighead, Philadelphia; Secretary, Mahlon G. Taylor Pottstown; Directors, James B. Craighead, J. M. Zook, Philadelphia; Charles K. Spatz, Boyertown; Mahlon G. Taylor, Pottstown.

PHILADELPHIA, PA.—It is said that the Fifth and Sixth Streets Passenger Railway Company will make a trial of compressed air on the North American Pneumatic Car Company's plans, invented by Frank H. Cathcart. The Traction Company operate the line, and the majority think that the compressed air talk is "all wind."

PITTSBURG, PA.—It is reported that Geo. W. Elkins will retire from the active management of the Pittsburg & Duquesne Traction on account of age. His son, W. L. Elkins, will succeed as president, but superintendent McDowell will be active head.

ALTOONA, PA.—Altoona & Logan Valley Railway power house burned, with total loss of machinery and ten cars, on December 21. Value of property destroyed, \$25,000.

PITTSBURG, PA.—Reports that the Duquesne Traction Company wants to break its ninety-nine-year lease with the Pittsburg Traction, vigorously denied.

### Rhode Island.

PROVIDENCE, R. I.—Interstate Street Railway Company goes into the hands of receiver. William G. Roelker, of the United Traction Company of New York asks it. Cornelius Sweetland is the receiver. The Interstate will be absorbed, probably, by the Union Company. Many franchises have been obtained but not many operated. President Daggett alleges the hard times as the cause of the failure.

PROVIDENCE, R. I.—January 2 the plant of the Inter-State Street Railway Company, at Farmersville, was destroyed by fire. Loss, \$100,000; insurance, \$60,000. One hundred men are thrown out of work.

### Tennessee.

NASHVILLE, TENN.—United Electric Railway Company elects officers as follows: T. W. Wrenne, President; M. M. Gardner, Vice President; E. G. Connette, General Manager; G. W. Cunningham, Secretary and Treasurer. Mr. Gardner takes the place of Isaac T. Rhea, who resigned from the board of directors.

NASHVILLE, TENN.—The United Electric Railway has been placed in the hands of the Nashville Trust Company and Thomas W. Wrenne as receivers. Hard times seem the cause of the failure. The earnings for 1892 reached \$342,000 and in 1893, \$334,000. The line embraces 50 miles of track, and is in good mechanical condition.

MEMPHIS, TENN.—W. R. Hall, general manager, is appointed receiver for the Raleigh Springs suburban line. Assets, \$384,000; liabilities, \$138,718. Principal creditors, local banks, General Electric Company and B. L. Drake, of Durham, N. C.

CHATTANOOGA, TENN.—Mr. Adams, of Corinth, Miss., succeeds S. W. Devine as president of the Chattanooga Electric Railway. A rumor that superintendent Young is to resign, is without foundation.

NASHVILLE, TENN.—T. M. Steger, and one Mr. Bannard, of New York, have gained control of the Rapid Transit Company. The line is a valuable one. Improvements will be made at once.

WINCHESTER, TENN.—Winchester, Paint Rock & Tennessee River Electric Railway elect Ellis Days, president.

### Texas.

DALLAS, TEX.—Stables and barns of the Consolidated Traction Company burn, destroying 30 cars and 60 mules. Receiver S. P. Cochran, places the loss at \$55,000; insurance, \$31,000.

WACO, TEX.—A. Zintgraff, Denison, is elected president of the Texas Street Railway Association. A theater circuit is agreed upon, to open May 1 and close October 1. Adjourned to January 24 at San Antonio.

### Utah.

SALT LAKE CITY, UTAH.—H. M. McCartney is granted a franchise for an electric or cable railway north-west from Capitol Hill. Two other franchises were quashed, and it is doubtful if the one passed will stand unless amended.

OGDEN, UTAH.—The pioneer Electric Power Company, of Ogden, has its ordinance passed.

### Washington.

SPOKANE, WASH.—The Chelan country is said to be about to boom, a the Northern Pacific and the Great Northern are both to put in branch lines, and interconnect with electric railways.

PORT TOWNSEND, WASH.—Dan Starrett has bought the street railway here and is improving the line considerably.

### West Virginia.

PARKERSBURG, W. VA.—Parkersburg Street Railway Company, horse, has sold its franchise to the American Construction Company of Boston. It will be changed to electric and \$200,000 expended on it before May 1st.

### Wisconsin.

MADISON, WIS.—W. H. Lamprecht, of Cleveland, O., is elected president of the Street Railway Company, and H. C. Welch secretary and treasurer, Geo. H. Shaw, superintendent. The directors recommend continued improvement of the line.

OSHKOSH, WIS.—E. E. Stevens, G. C. Tyrrell and A. C. McComb are officers of a real estate men's organization, to see that the town has an electric railway line by next year.

MILWAUKEE, WIS.—The formality of electing officers for the Hinsey line has been gone through. The Villard people, H. C. Payne, et al., were made managers.

FT. HOWARD, WIS.—It is rumored that Edward Morton, of New York, wants to build a street railway here, and to connect with Green Bay.

## NORTHWESTERN ELECTRICIANS.

The Northwestern Electrical Association will be held January 17-18, at Milwaukee, at the Hotel Pfister. A number of interesting papers will be presented. W. W. Low, of Chicago, will discuss "New Things in Electricity;" Prof. D. C. Jackson, Madison, "Essential Station Instruments;" "The Economical Use of Transformers;" W. Foreman Collins and P. J. MacFadden, Chicago; "Corliss Compound Engines;" E. L. Debell, Sheboygan; "Advantages of Direct Connection," W. N. Stewart, Chicago; "How Shall Members Buy Supplies," H. C. Thom, Madison.

### Only One Night Out to Florida.

The morning train via the Monon Route connects at Cincinnati with the 7:00 p. m. Through Vestibuled Train, on the Queen and Crescent Route, reaching Jacksonville at 10:50 p. m. the following day. The service of this popular line is unsurpassed by any line to the South. For rates, address City Office, 232 Clark street, Chicago, or Frank J. Reed, G. P. Agt., Monon Block, Chicago.

## PATENT OFFICE GOSSIP.

THE REVIEW said last month that the monthly list of fool inventions in the street railway field was steadily on the decrease. While we still believe this to be true there is occasionally an issue that shakes this optimistic view of affairs. This occurred when our eyes were for the first time feasted on the drawings of Number 510,138. After recovering from the dizzy feeling that the first glance caused, it appeared that it is an automatic governor and brake combined, with a spring motor for storing up energy when going down hill. It can safely be said that the novelty of this patent will never be questioned. There has never been anything like it.

THE support for trolley wires, (510,217), invented by Mr. Walker, of Denver, is a trolley clamp, which is not without merit, although it dif-

CHAS. F. WINKLER'S electric car truck, (510,661), has been attracting considerable attention, recently, because of its having been put on the market. It consists of two armatures revolving in a single magnetic circuit. See illustration.

THE electric locomotive (510,947), is the same as the foregoing, except that the field magnets are flexibly jointed to allow of independent motion of the armatures on a flexible truck.

THE Columbia & Donegal Street Railway Company, of Columbia, Pa., wishes to make the line a regular United States postal route. Frank S. Given, the live superintendent, is pushing the matter.

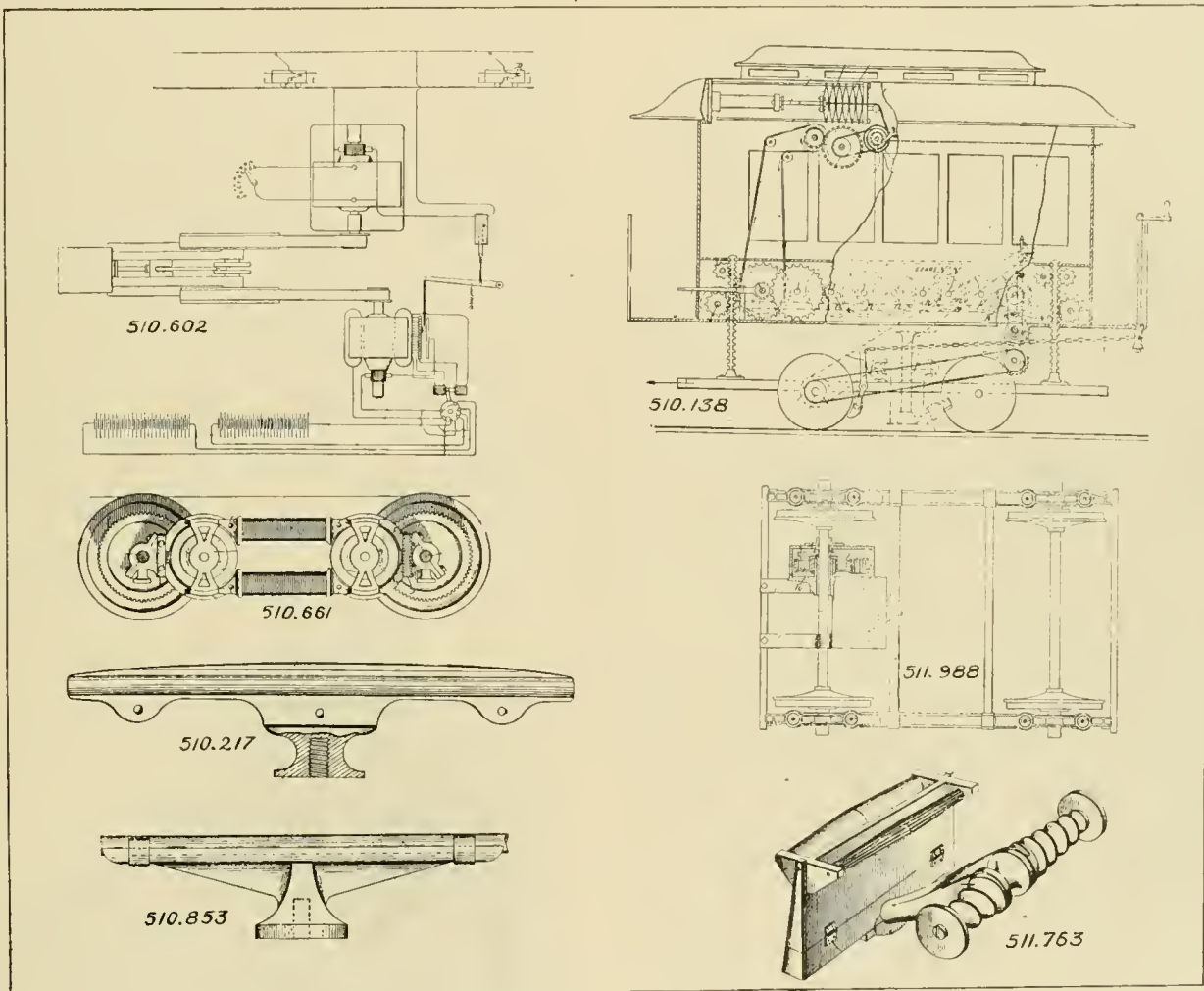

fers radically from those now in use. The wire is entirely enclosed by the clamp instead of being left bare on the under side, as is usual. The lip *d* is intended to provide a smooth path for the wheel over the clamp. With the clamp entirely surrounding the wire, it is almost impossible for the wire to drop out.

MR. HUNTER'S dynamo electro regulator, (510,602), is a novel method of utilizing storage batteries in central stations. The engine is connected to two machines, one of which is a motor, the other the regular railway generator. When the load is below average a part of the generator current is charging a set of secondary batteries. When load rises above average an automatic switch worked by the current flowing to the trolley line turns the battery current into the motor so that it helps the engine.

A DESCRIPTION of 510,469 can be found in the REVIEW for October, 1893.

THE SAFETY BRAKE SHOE COMPANY, of Boston, W. W. Whitcomb president, reports constantly increasing demand for their composite brake shoe, and have shown us abundant evidence that a great many street railways are adopting it for their standard shoe. The company has made arrangements with Wm. E. Tucker, 130 Main street, San Francisco, for the manufacture and sale of their shoes on the Pacific coast. They have also established an agency with Arthur S. Partridge, Bank of Commerce building, St. Louis, and will undoubtedly have one in Chicago before long. The company's office in Boston is at 620 Atlantic avenue.

## STREET RAILWAY PATENTS.

Compiled by the Street Railway Review.

ISSUED DECEMBER 5, 1893.

Car fender, Frederick W. Brown, Cambridge, Mass.....	509,996
Conduit electric railway, William R. De Voe, Shreveport, La., assignor of seven-twelfths to C. W. Dawley, Dallas, Tex., and Patrick B. Cash, Shreveport, La.....	510,061
Emergency wagon for electric line work, Edwin S. Breed, Water- bury, Conn.....	510,113
Street car, Henry W. Hooton, Salt Lake City, Utah.....	510,138
Conduit railway trolley, Paul C. Just, Chicago, Ill.....	510,142
Cable crossing, William W. Bailey, New York, N. Y.....	510,151
Trolley and trolley switch, David V. B. Smart, Troy, N. Y.....	510,201
Support for trolley wires, James E. Walker, Denver, Col.....	510,217
Sanding device for cars, Herbert H. Hennegin, St. Louis, Mo.....	510,258
Electrically operated railway switch, Henry L. Falco, Brooklyn, N. Y.....	510,384

ISSUED DECEMBER 12, 1893.

Crossings for railways and tramways, John E. Billups, Cardiff, England.....	510,399
Cable tramway, William N. Colam, London, England.....	510,469
Trolley wire support, Leroy F. Pfouts, Canton, O.....	510,485
Signal for cable roads, Margaret A. Edwards, San Francisco, Cal., administratrix of Edward W. Edwards, deceased.....	510,593
Dynamo electric regulator for an engine driving a generator, Rudolph M. Hunter, Philadelphia, Pa., assignor to the Thomson-Houston Electric Company of Connecticut.....	510,602
Electric railway conduit, William R. De Voe, Shreveport, La.....	510,634
Conduit electric railway, John P. Michieli, San Francisco, Cal.....	510,647
Electric car truck, Chas. F. Winkler, Troy, N. Y.....	510,661

ISSUED DECEMBER 19, 1893.

Elevated railway system, Burr F. Barnes, Circleville, O.....	510,878
Fender for street cars, William B. Miles, Holyoke, Mass.....	510,922
Electric locomotive, Chas. F. Winkler, Troy, N. Y., assignor to the United Columbian Electric Company of New Jersey.....	510,947
Electric railway switch and crossing, William W. Hendrix, Bowl- ing Green, Ky.....	511,01
Electric railway trolley, William W. Hendrix, Bowling Green, Ky.....	511,018
Electric railway trolley, William W. Hendrix, Bowling Green, Ky.....	511,019
Street railway track, William C. Wood, Brooklyn, New York, assignor to the Lewis & Fowler Girder Rail Company, same place.....	511,068
Signal for cable railways, Joseph Sachs, New York, N. Y.....	511,163
Electrically operated railway switch, Chas. A. Stone, Newton and Edwin S. Webster, Boston, Mass.....	511,173
Elevated railway, John N. Valley, Jersey City, N. J.....	511,179
Electric regulating switch, Edwin A. Barber, Watertown, N. Y.....	511,187
Sanding device for cars, James R. Dougherty, St. Joseph, Mo.....	511,199
Closed conduit electric railway, William S. Smith, Berkeley, Cal.....	511,254
Power transmitting and speed regulating mechanism, William Cooper and Geo. P. Hampton, Minneapolis, Minn., assignor by mesne assignments to the Cooper-Hampton Electric Company, same place.....	511,289

ISSUED DECEMBER 26, 1893.

Cleaning device for railway conduits, John C. Love, Philadel- phia, Pa., assignor to the Love Electric Traction Company, Chicago, Ill.....	511,341
Conduit railway trolley, John C. Love, Chicago, Ill., assignor to the Love Electric Traction Company, same place.....	511,342
Trolley for conduit railways, John C. Love, Chicago, Ill., assignor to the Love Electric Traction Company, same place.....	511,343
Trolley wire crossing, Henry Geise, Philadelphia, Pa., assignor one-half to Edwin Jaquett Sellers and Horace Pettit, same place.....	511,419
Automatic railway switch, Chas. S. Hoenes, Milwaukee, Wis.....	511,425
Life guard for street cars, Chas. W. Howe, Waltham, Mass.....	511,428
Electric locomotive, John G. McCormick, Louisville, Ky.....	511,448
Conduit for electric railways, Henry D. Oler, Paterson, N. J.....	511,452
Car fender, George E. Cates and Diederrech Reuschenberg, Brooklyn, N. Y.....	511,586
Cable railway, Charles I. Earll, New York, N. Y.....	511,596
Cable railway, Charles I. Earll, New York, N. Y.....	511,597
Fender for street cars, David Flanders, Watertown, Mass.....	511,604
Radial car truck, Louis J. Hirt, Boston, Mass.....	511,615

Electric railway switching mechanism, Chas. J. Kintner, New York, N. Y.....	511,627
Trolley base, James L. Maudlin, Cleveland, O., assignor of one- half to Frank J. Lewis, same place.....	511,634
Car fender, James W. McKinnon, New York, N. Y., assignor of two thirds to Sarah B. McLeod and Ann M. Downs, same place.....	511,640
Motor for cars or other purposes, David P. Sanders, Williams- port, Pa.....	511,652
Truck frame for motor cars, Chas. E. Canfield, Chester, Pa., assignor one-half to Henry Cochran, same place.....	511,680

ISSUED JANUARY 2, 1894.

Trolley, William T. Duncker, Steelton, Pa.....	511,763
Trolley mechanism for electrically propelled vehicles, Curtis H. Veeder, Lynn, Mass., assignor to the General Electric Com- pany of New York.....	511,824
Street railway special work, William C. Wood, Brooklyn, N. Y., assignor to the Lewis & Fowler Girder Rail Company, same place.....	511,831
Trolley wire support, Chas. T. Lee, Boston, Mass., assignor to the Johns-Pratt Company, Hartford, Conn.....	511,853
Electric locomotive for elevated tracks, Charles H. Roberts, Hart- well, O.....	511,862
Section insulator, Henry M. Brockbank, Brooklyn, N. Y.....	511,928
Trolley catcher, George E. Gay and John H. Parsons, Augusta, Me.....	511,941
Electric locomotive, Edward M. Bentley, Boston, Mass.....	511,988
Roadway and vehicle therefor, Elmer O. Evans, Boston, Mass.....	512,174
Safety guard for railway cars, William J. Foster, Hoboken, N. J.....	512,181
Overhead trolley wire switch, George W. Mackenzie, Moses B. Sloan and Thomas C. Sloan, Beaver, Pa.....	512,201

## THE DODGE CLUTCH SHIFTER.

The Rice Machinery Company has upon the market a new gear, made by the Dodge Manufacturing Company of Mishawaka, Ind., for moving friction clutches into and out of action. It is particularly adapted for floor stands but can be used on independent standards. Reference to the engraving tells the story of the action. The trun-

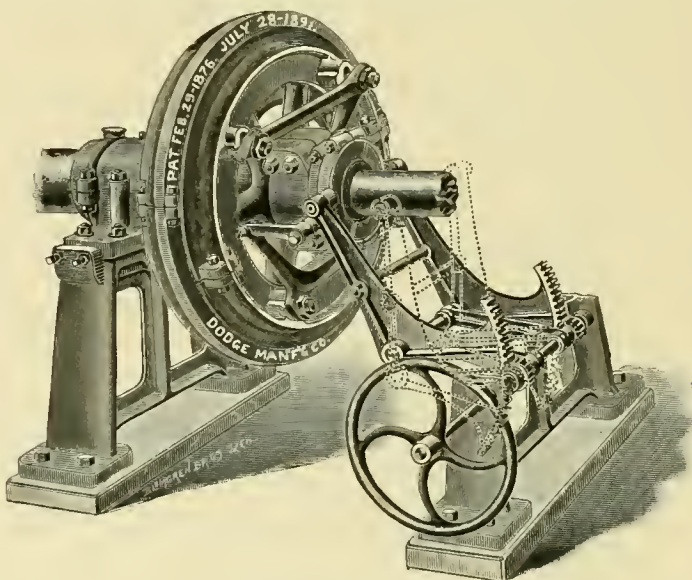

DODGE CLUTCH SHIFTER.

nions in the Dodge shifter are held in bearing holes in the end of the bell crank arms, which are part of a rigid frame. These bell crank arms, with the links that tie them to the pinion shaft, constitute a clutch that increases in power as the resistance increases. The bell crank arms end outwardly in a gear segment, meshing with pinions that are easily and firmly operated by a hand wheel.



**ECHOES FROM THE TRADE.**

SARGENT & LUNDY, with present work, are very busy. The Harrison street lighting station absorbs the most of Mr. Sargent's time.

THE FALLS RIVET & MACHINE COMPANY says with a smile, "Two or three big orders in view; will see you later on the subject."

ROBERT WETHERILL & Co., Chester, Pa., will make eight Corliss engines and ten boilers for Philadelphia, Pa., Traction Company.

THE RIES ELECTRIC SPECIALTY COMPANY, of Baltimore, reports business exceedingly good, and their factory running day and night.

THE Chicago agent of the Ball Engine Company, Mr. McBrier, says that he looks forward to an awakening of business within the next few months.

THE American Electrical Works, of Providence, R. I., are now established in their new quarters at East Providence and find every convenience there.

TAYLOR, DEE & MACK, formerly Taylor, Goodhue & Ames, of 348 Dearborn street, begin the new year with bright prospects and an increased clientage.

AMONG recent changes by addition, we note that J. W. Parker & Co, 41 North Seventh street, Philadelphia, will act as sales agent for the Ball engines, of Erie, Pa.

PECKHAM'S truck has been distinguished lately by a description in the London paper, *Engineering*. Coming from such a source, this may be considered a great compliment.

WILEY & PHELPS, at 1422 Monadnock, will handle the De Laval steam turbine and electrical goods. The firm is well known to the electrical fraternity and will be well received.

WALTER S. MCKINNEY, 225 Dearborn street, was the captor of the power plant contract for Sandwich, Ill. The bid calls for two horizontal tubular boilers, pump, injector, heaters, and engine of 120-horse-power.

THE ALTOONA MANUFACTURING COMPANY, which makes the Green automatic cut-off engine, has issued a striking bit of literature in the form of a folder, containing descriptions of the engines and users of them.

THE CONSOLIDATED CAR HEATING COMPANY have begun suit against the Chicago & West Michigan Railroad for infringement of the Sewall hose coupling used on the steam heating apparatus of the latter's cars.

BABCOCK & WILCOX have settled their Western offices in an elegant suite in the Masonic Temple, where Mr. Palmer sways the sceptre as of yore. The offices are much more convenient, light and agreeable than the old stand.

THE GENETT AIR BRAKE COMPANY, Chicago, has not stopped stopping cars. The good reports of the efficiency of the Genett brake are unvarying, and a constant stream of enquiry keeps the office as busy as the proverbial bee.

THE AMES IRON WORKS reports from its western agent, W. E. Jones, at 18 South Canal street, that business is as lively as can be expected under the circumstances, and that the prospects for the Ames engines in the near future are bright.

THE CONSOLIDATED CAR HEATING COMPANY, Albany, N. Y., has received a second order from England for direct steam storage heating equipments. These equipments are so arranged that the temperature in each compartment can be separately regulated.

J. S. DENNISTON, 911 Monadnock Building, says, that the Nuttall gears and pinions are still holding their place with the western trade, and that the Davis car shade is the coming feature of western cars; a recent order from a prominent car builder called for 300 of them.

THE CARD EQUIPMENT COMPANY, of Mansfield, Ohio, is the latest bidder for street railway patronage. The company is said to be well backed for the manufacture and sale of the apparatus designed by Geo. F. Card, and the specialties will include street railway motors and equipment.

THE M. C. BULLOCK MANUFACTURING COMPANY, 1170 West Lake street, Chicago, is making rapid progress toward the marketing of the Willan's Central Valve Engine, a description of which was given recently in the *REVIEW*. The enquiries received show that interest on the subject has been wide-spread.

WILLIS L. ADAMS, 84 Adams street, hopes for better times in the near future, and thinks himself as well blessed in the matter of trade as anyone. A fire in the building recently caused the firemen to bring a hose through Mr. Adams' office, which mussed up his new carpet and smashed his door glass.

A. G. HATHAWAY, of Cleveland, has just shipped four of his well-known transfer tables to London, Eng., six to various points in South America and one to Paris. The latter will be equipped with General Electric motors. Few American street railway specialties are known to a wider circle than the Hathaway transfer table.

GOODHUE & LINCOLN, at 1564 Monadnock block, are new dealers in electrical material. Mr. Goodhue was formerly of Taylor, Goodhue & Ames. The firm handles Wagner motors and dynamos for direct and alternating currents. Mr. Lincoln is well known to the telephone and railway fraternity, and comes from the Hub.

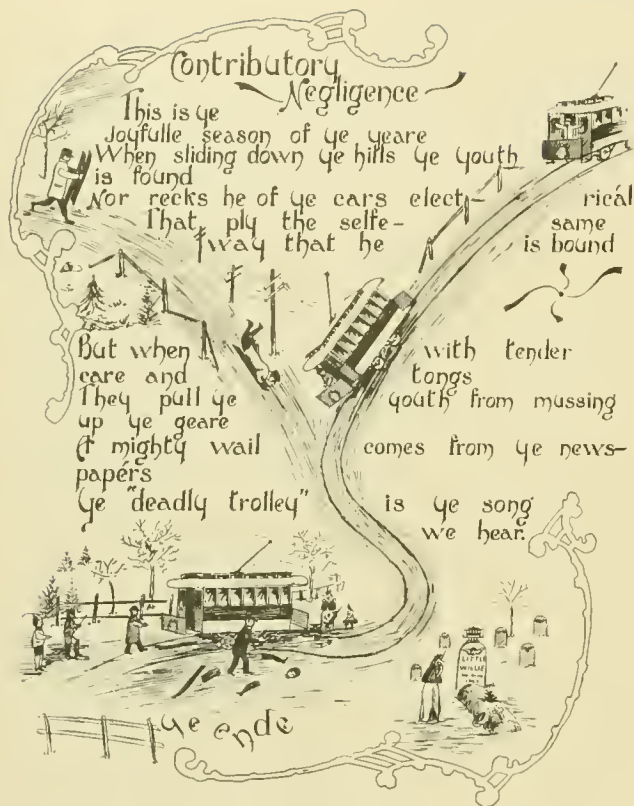

THE STANWOOD MANUFACTURING COMPANY, Chicago, has a recent order for fifty car equipments of the well known Stanwood steel step. The success of the Stanwood step as an accident saver, and consequently as a dividend saver, is too well known to require much mention beyond that fact that more managers than ever appreciate the fact.

THE GENERAL ELECTRIC COMPANY, in common with the smaller concerns, finds railway business quiet, but expects a large increase of trade within a month or six weeks. The unusual caution of street railway financiers and the hard times, combine to arrest the progress of railway building for the present. The subject of elevated electric railways is the present subject under the most interesting discussion.

THE STANWOOD MANUFACTURING COMPANY has the best of reports from the use of the Stanwood steel step, and the opinion of managers of the larger roads in adopting them speaks volumes for the economy and comfort of knowing that the passenger's foot has a firm foundation, no matter how careless the owner of the foot may be. A single order to equip fifty cars was one of the features of the past week.

THE WESTINGHOUSE ELECTRIC & MANUFACTURING COMPANY reports little doing in large enterprises for the immediate future, but otherwise the business is as good as can be expected under the circumstances. The future for supplies will be one grand rush when everything about the repair shop and supply room has been used up,

and summer traffic requires more cars and facilities. The lighting business is reported active in certain directions.

THE ELECTRIC RAILWAY EQUIPMENT COMPANY, of 81 and 83 East Front street, Cincinnati, in placing a handsome bronze electric car on the editorial desk, says: "In presenting our compliments of the season, we beg to place on your desk one of the products of our foundry, in the shape of a souvenir paper weight, trusting that it may hold down many pleasant lines which help make up for you a Merry Christmas and Happy New Year."

WARREN WEBSTER & COMPANY'S agent, W. D. Pickels, says that the Webster vacuum feed water heater and purifier business is booming, and that greater interest than ever is being taken in the subject of feed water purification. Several recent equipments of electric plants of from 1,500 to 4,000-horse-power have been installed. The inland power users are waking up to the economy of recent methods, and the Webster vacuum heater and purifier is doing its best to hurry forward the procession.

THE COMPLETE ELECTRIC CONSTRUCTION COMPANY has established its western office, under the well known engineer, Clift Wise, at 1,401 Monadnock Block. The company takes contracts for complete construction of street railway plants, and has a complete corps of engineers and experts. The main offices are at 121 Liberty street, New York. The president and general manager is John A. Seeley; vice-president, W. H. Baker; secretary-treasurer, C. O. Baker, Jr., and auditor Mills H. Landon.

THE Laconia Car Company, Laconia, N. H., among the largest builders of steam railroad equipments in New England, are now building street railway cars of all kinds, electric, cable and horse. The reputation of this company as builders of highest grade of cars is sufficient proof that their street railway cars will be of the very best workmanship. Their facilities are unsurpassed for turning out cars at low prices, and giving prompt and reliable deliveries. The company employs between 600 and 700 men, and has the best skilled labor. Their street railway department will be in the charge of F. E. Huntress, 8 Oliver street, Boston. The Laconia Car Company will build according to specifications, or will duplicate any cars now in service to the satisfaction of patrons.

THE STANDARD PAINT COMPANY, of New York City, begins the current year with bright prospects, judging from their past record for the recent depression. They write: Notwithstanding the exceeding depression of business this year, we have sold more P. & B. compound, tape, and armature varnish to street railways than any previous year, which shows that the electric roads appreciate our material. We have this year supplied a very large number of electric roads in the United States

W. C. BAKER, 143 Liberty street, New York, the inventor of the Baker street car heater, is adapting a hot water system for street railways.

THE HEINE SAFETY BOILER COMPANY, of St. Louis, has, among recent orders, a commission for eight boilers of 375-horse-power each, for the Midwinter Fair.

OUR Milwaukee correspondent says that the Milwaukee Street Railway Company has five Lewis & Fowler sweepers, and that the tracks are kept in splendid condition.

THE P. WALL MANUFACTURING COMPANY, of Pittsburg, is doing a good business. A recent shipment to Australia shows that foreign roads appreciate the dulcet tones of the Wall gong.

SAMUEL LEWIS, 10-18 Larrimer street, Brooklyn, N. Y., is the maker of wood mats for street cars that are used by half a dozen big builders. The mats are convenient, strong and cleanly.

THE VALLEY STEEL COMPANY, of Belleville, Ill., is the successor of the Belleville Steel Company, which failed recently. The new concern is capitalized at \$400,000 and began running with 800 men.

A. E. DEMANGE, one of the projectors of the Peoria-Pekin Electric Railway scheme, has bought the McLean County Fair Grounds and all its buildings, paying for it \$9,050. He will turn it into a summer resort for the railway.

THE R. A. CRAWFORD MANUFACTURING COMPANY, of Pittsburg, has reason to be proud of the reception of their fender accorded by the many different roads now using them. Second orders have been given in every case, and the universal word is, that the saving in accidents compensates the expense of their application.

WM. HAZELTON, III., has opened offices in the Have-meyer building, New York, as the agent for the United States of the Societe Anonyme Industrielle des Etablissements Arbel, Rive-de-Gier (Loire), France. The company makes wrought iron and forged centers for all kinds of wheels and had an extensive display at the World's Fair. The Arbel wheels are to be congratulated upon their introducer.

F. R. CHINNOCK, who for the past two years has been the general eastern agent of the Ball Engine Company, of Erie, Pa., has resigned his agency with that company and will again enter the electrical field, in which industry he was so long and successfully identified. Mr. Chinnock will surely be successful in the larger and broader field of electricity, in which line he was formerly known as the agent of the Edison General Electric Company for eight years.

## PERSONAL.

TREASURER D. C. McMARTIN, of the Austin Dam Railroad Company, of Austin, Tex., spent the holidays in Des Moines, Iowa.

WILLIAM ERSKINE has been elected president of the Wheeling Railway Company, Wheeling, W. Va., vice Judge J. J. Jacobs, deceased.

THE daughter of P. E. Hall, the street railway owner, of Cedar Rapids, Iowa, is announced as engaged to Charles W. Higby, of Minneapolis.

O. J. WINN, the manager of the Grand Island, Neb., Street Railway, was presented with a magnificent gold watch by his employes on Christmas.

JAMES S. HAGERTY, of Baltimore, a prominent director of the Traction Company, was married last month in Chicago to Mrs. Marie Lawrence, of the latter city.

THE retiring assistant superintendent, M. E. McCaskey, of the Birmingham Traction Company, of Pittsburg, was presented with a beautiful diamond ring and pin by his employes, January 1.

E. M. CAMPBELL, superintendent of the Ottumwa, Iowa, street railway, and Miss Rose Metzger, of Independence, Kansas, were married Christmas Day, at the home of the bride's parents.

G. J. MELMS, formerly receiver of the Hinsey street railway line, of Milwaukee, has left for Europe. to be absent about six weeks. He will go to Switzerland, and Mrs. Melms will return to Milwaukee with him.

D. W. HIGGINS, for five years president of the Victoria, B. C., Electric Tramway & Light Plant, has been succeeded by Major C. T. Dupont. Mr. Higgins resigned to give all his attention to the electric light part of the concern.

BEN WILLARD, of the construction engineering force of the General Electric and Thomson-Houston Companies for the past eight years, has accepted the post of constructing engineer of the New Orleans City & Lake Railway Company and assumes the office January 1.

JOHN D. CRIMMINS has a hobby for collecting autograph letters. He also is an enthusiast on the history of New York city, and intends to write a history of the metropolis, before many years, and then give his already magnificent collection of data to a library or institution.

THE Consolidated Traction Company, of Newark and the South Orange & Newark Railroad Company, have entered into a binding agreement to withdraw all passes. At least 1,000 such favors were in use. If there are any persons legally entitled to free rides the companies will supply them with new 5-cent pieces.

## FULTON "IMPERIAL" TRUCK.

The Fulton Truck & Foundry Company is the successor of the well known Fulton Foundry Company, of Cleveland. In addition to its works at Cleveland, a plant is now being erected at Mansfield, O., for the manufacture of trucks, crossings, switches, and other street railway supplies. The latter plant will be very complete. Not the least interesting of the new developments in connection with this company is the announcement of two new steel trucks. The Fulton people have previously made only wooden trucks, and still make them, but will now be able to give their customers the advantage of a choice between the two kinds.

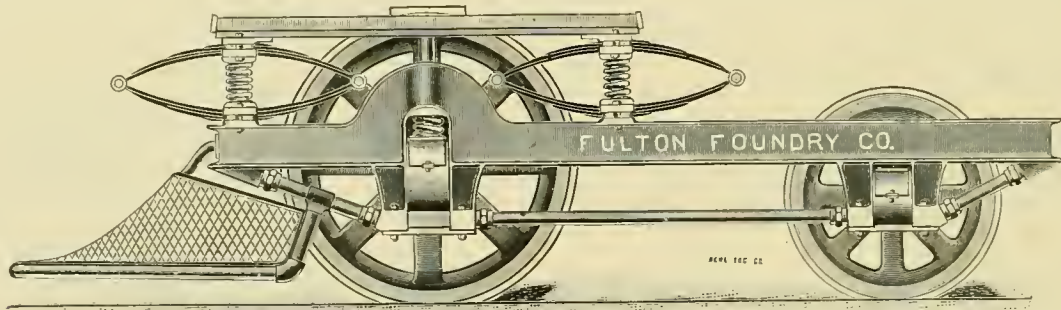

DOUBLE STEEL TRUCK "IMPERIAL."

The "Imperial" steel trucks are the design of the president and general manager, W. E. Haycox, of thirteen years experience in street railway work. Both the single and double trucks are here shown. The main frames are cast steel I beams, cross connected with rolled steel I beams, the joints being made with fish plates and rivets. The side frames of cast steel are bent at the corners, and joined to the rolled steel cross beams about ten inches from the corner, making the joint on a straight line, and the truck much more rigid than if it had corner joints. The pockets for receiving the springs and the lugs for the under truss are cast with the frame. In fact, very few bolts and rivets are used in the assembling of

The strong and simple form of fender put on these trucks is also shown in the engravings. A new equalizing brake is used on single trucks, and when desired, trucks are supplied with double tread wheels, having separate brake rims. It is claimed that the practical use of these demonstrates the theory that the brake shoe on the ordinary wheel shortens that wheel's life 60 or 75 per cent.

## MONTREAL PARK AND ISLAND RAILWAY OPENED.

January first was the date of the trial trip on the Montreal Park & Island Railway. The road is at present laid between Montreal and Sault au Reccollet, on the north

side of Montreal Island. It is the intention to make it a belt line, completely encircling the island. There is good prospect that the project will be a paying investment, as it taps the suburban territory of Montreal, and it is the intention to carry freight and all kinds of supplies to the residents of the district. This freight business alone will made a large item of income, as the present rates are very high. With this road reaching every town on the island, development will undoubtedly be rapid. The system, when completed, will comprise 125 miles of track. Those present on the trip were the Hon. J. R. Thibaudeau, W. S. Williams, managing director, A. J. Corriveau, R. Stanley Bagg, A. E. Lewis, James Quinn,

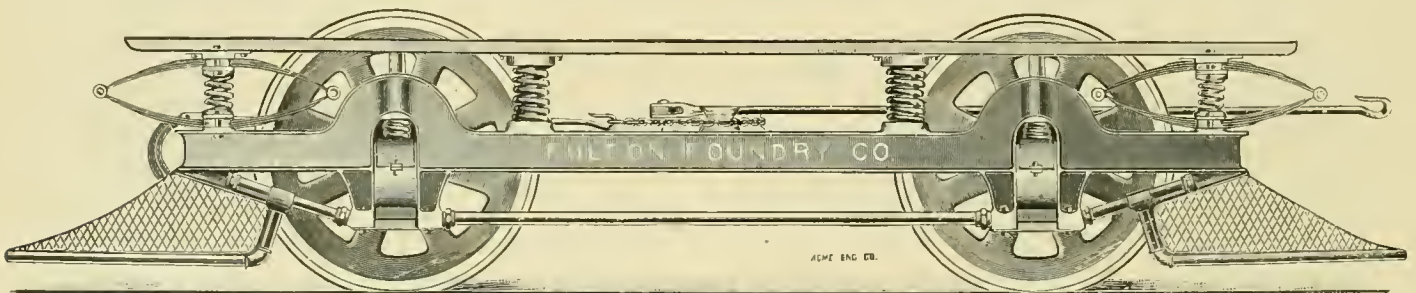

SINGLE STEEL TRUCK "IMPERIAL."

this truck. The combination coil and elliptic springs at the end are adjusted to prevent strain on the elliptics, by having the spirals take the greater part when the elliptics have reached the point of overload. A heavy steady pin runs from the subsill over the journal box into the main frame. This is one of the prominent features of the Fulton trucks, and contributes not a little to their success.

Roy and Marble, the engineers in charge of the construction, and the press representatives.

PHILADELPHIA's new trolley lines on Thirteenth and Fifteenth streets report traffic augmented one hundred per cent. Many are curiosity riders. It is reported that the cable line will be electrified next year.

AN ALUMINUM REGISTER.

The man who said that the next age would be the Aluminum Age probably had a prophetic eye on the elegant fare register made by the International Register Company, of 300 Dearborn street, Chicago, and illustrated herewith. It is called "The Aluminum."

It may be seen from the engraving that the register is of double clock face, stationary, design, having a permanent register, with a capacity of 100,000, and a trip register, capable of being turned back to zero.

The permanent register is made entirely of cut gears, without spring or pawls, thus giving strength and durability. It cannot possibly be moved backward or for-

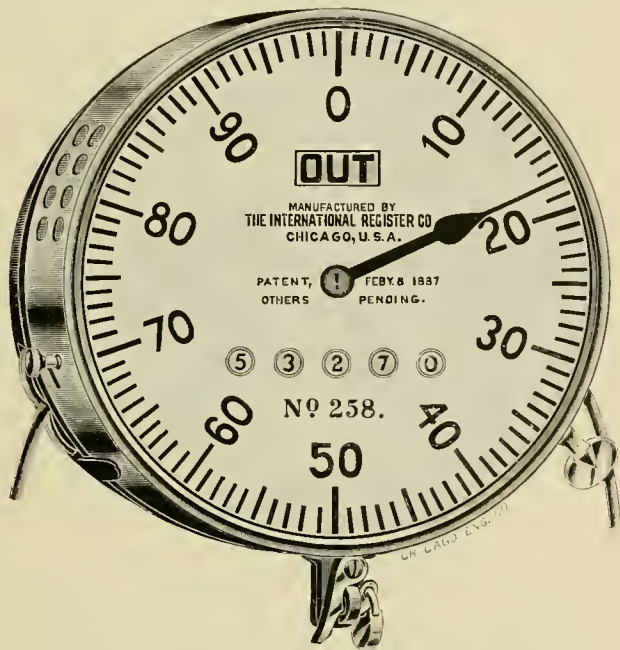

THE ALUMINUM.

ward without pulling the cord, and actuating the entire mechanism. The makers claim that even if the case, dial and all be removed, the total cannot be changed except as described, an advantage not requiring discus-

from ringing up fares accidentally when meaning to signal the driver, as it will not operate with a short, quick jerk. Pure aluminum dials make the register's face a pretty and durable one, retaining its luster at all times, not cracking or corroding, and making it look new at all times.

The register is of the standard 12-inch size, finished in full nickel, and operated by cords and pulleys or by rods. In fact, Manager Englund has every reason to be proud of his elegant, durable and efficient handiwork.

GRAHAM'S DIVIDEND EARNER.

The truck is an important factor in the wear and tear of rail joints and switches, and this must be considered in selecting an equipment. The peculiar feature of the Graham truck, here illustrated, is that the load is, so to speak, suspended over each wheel. In other words, the entire spring is between each wheel and the truck frame, instead of between the truck frame and car body, as with the majority of trucks now on the market. The inequalities of the roadbed are taken by the wheels individually.

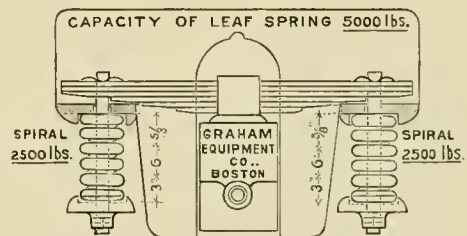

ELEVATION OF SPRING SUSPENSION.

The weight of the car and its load, up to fifty passengers, is taken by the spiral springs. Beyond that point the spirals are inactive, and the leaf springs take the load. But twenty-four bolts are used, all of them  $\frac{5}{8}$ -inch. The car body is held by four bolts. Another desirable feature is that the body is only twenty-three inches from the ground. The Graham people are using a 5-inch steel I beam for trucks to go under open cars, and extending the

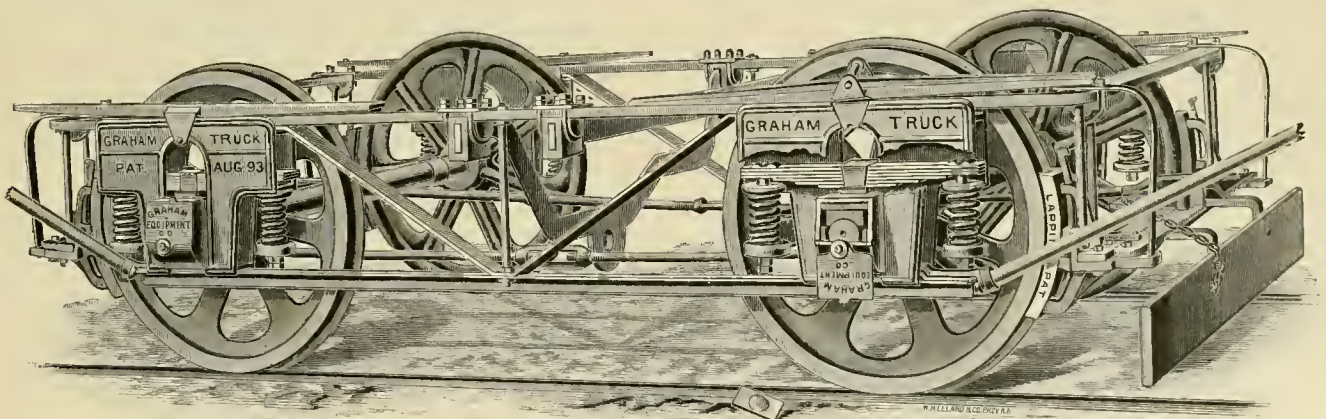

GRAHAM'S "DIVIDEND EARNER."

sion. Another feature is the long stroke,  $7\frac{1}{2}$  inches, by means of which the quick and indistinguishable jangle of four or five fares at once is avoided, and each fare rung up distinctly and slowly. This also prevents passengers

frame out from twelve to eighteen feet, as required, giving the sill a rigid support. The 5-inch steel I beam is supported by a special brace of 3-inch channel steel, making a cantilever truss for the sills.

## DISASTEROUS CONFLAGRATION AT ATTLEBORO, MASS.



**ONE** CHEAP hand-lantern, worth about half a dollar, exploded, January 2, at the Interstate Electric Railway power house at Attleboro, began an \$80,000 fire, tied twenty-four miles of electric railway, left a town without street lights, checked incandescent lighting in three large villages, and threw one hundred men indefinitely out of employment. The insurance was \$56,000.

The plant was shut down at 12:30 a. m., as the last car comes in at that time and Attleboro is shrouded in the robes of night, and all its pious citizens go to bed. The engine-wiper was crawling over the big engine and through the fly-wheel, making his pet's morning toilet, when the little hand-lantern that afforded him his only light, exploded and ignited a pile of oily waste. The flames found free fuel, and fanned by a stiff north breeze, the whole building was soon a roaring furnace. The morning was bitterly cold and the firemen worked under great difficulty.

The dynamo room, 105 feet by 45, and an ell 20 by 20 feet went first, destroying two 250-horse-power compound condensing engines, one 100-horse-power, one 600-horse-power engine, four railway generators, one 2,000 light alternator, eight arc light machines and considerable large repairs. The remainder of the plant soon followed. Since this date the only facilities of Attleboro, North Attleboro, Wrentham, Seekonk, Mass., and Pawtucket, R. I., have been oil lamps and horse cars.

### OBITUARY.

HENRY W. GILLER,

for over a quarter of a century cashier of the Brooklyn City and Newton Railroad Company, was stricken by apoplexy at his desk December 20. Mr. Giller was born in 1844, and was in railway work all his life. He leaves a widow and two children.

The long, intimate career of Geo. H. Babcock and Stephen Wilcox, ending in their decease within a month of each other, is a coincidence worthy of the extended comment occasioned. Mr. Babcock died December 16 and Mr. Wilcox November 27, 1893.

STEPHEN WILCOX.

Mr. Wilcox was born in Westerly, R. I., to which town Mr. Babcock removed when a boy, from New York. While still a young man, Mr. Wilcox became interested and intimately connected with the development of the steam engine, and to this end studied all types of caloric engines, inventing one that antedated Ericsson's, besides spending considerable time and money on researches into oil and gas engines. All this investigation convinced him that the steam engine was the only practical solution for the problem.

GEORGE H. BABCOCK.

Mr. Babcock, whose experience was perhaps more varied than that of his distinguished compeer, began his mechanical career in a woolen mill, afterwards going into newspaper publishing at Westerly. As the first inventor of the polychromatic printing press his first fame was acquired. He was also the inventor of a printer's bronzing machine and devoted considerable time to the young art of photography. Following this mechanical career came several years' experience in the office of a patent lawyer, and an engagement as mechanical draftsman. While in this latter capacity the cut-off engine known as the Babcock & Wilcox was invented, and Babcock and Wilcox first became associated in business. The year 1867 saw the Corliss patent public property, and the Babcock & Wilcox engine became too expensive to build.

In 1856 Mr. Wilcox had invented the original of the inclined water-tube style of boiler. This was improved



GEO. H. BABCOCK.

STEPHEN WILCOX.

on, however, by both the men and their employed engineers.

In 1868 they came to New York to push the engine business and started the manufacture of small engines, as the New York Safety Steam Power Company, but withdrew in 1878 to give all their time to the development of the since famous boiler. In 1881 a stock company was formed and Mr. Wilcox dropped active business, leaving Mr. Babcock at the helm for several years longer.

Both men were of remarkably forcible intellects, both valued citizens of their own towns and both benevolent to a high degree. Mr. Babcock was a forcible writer and lecturer on his specialty and a competent literary critic.

To few men comes the honor and fruit of early genius and industry in such abundance as to these pioneers of stationary engineering, and few inventors have had greater reason to be satisfied with a life's work; "and in their death they were not divided."

At Logansport they call it the International Electric Railway at the World's Fair. The Logansport Reporter also remarks that as an engineering feat it was successful, but that it lost money. "It cost \$1,000,000, earned over \$5,500,000, and paid 25 per cent to the Exposition people." Pretty good for losing money.

LUNDELL STATIONARY MOTORS.

An unique form of field magnet is embodied in the construction of the Lundell dynamos and motors, which has attracted some attention recently. There is but one field

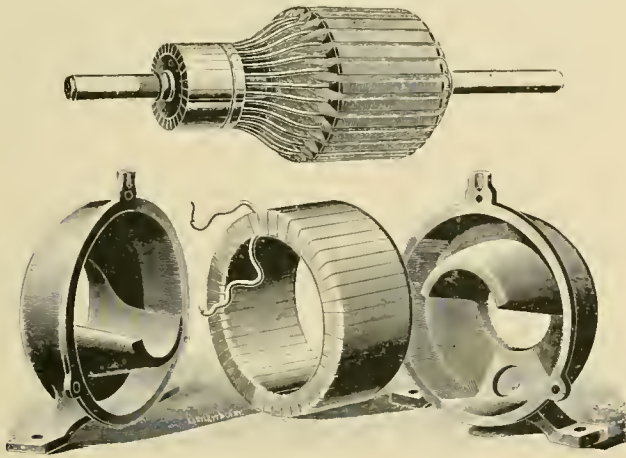

LUNDELL MOTOR—PARTS.

coil and it encircles the armature in a plane perpendicular to the armature journal. The nature of the magnetic circuit can best be understood by a glance at the engraving, which shows the field coil in the center and the two

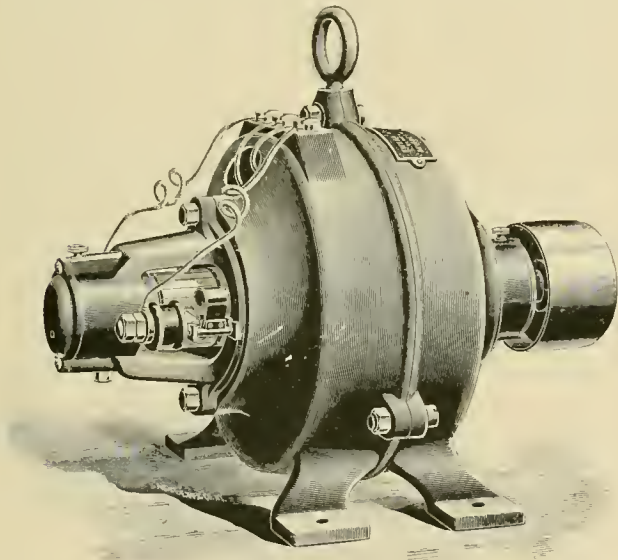

THE LUNDELL MOTOR.

halves of the field magnets on either side. The result of this peculiar arrangement is to make a compact machine with an iron covering nearly encasing it.

THE NORTH-WESTERN L.

The most absorbing topic of rapid transit interest in Chicago of the past month has been the North-western Elevated, as it is called, which proposes an elevated railway line from Randolph street, between the lake and Market street, to the North Side, taking a westerly direction.

FOREIGN FACTS.

AN electric railway is to be opened between Bordeaux and Bouseat, France.

WILLIAM WALLACE DUNCAN, the well known stock-broker and tramway expert, and author of "Duncan's Tramway Manual," died recently.

EARTHENWARE ties are an innovation into Japanese railway practice, and the results are said to be fairly good. The method of making is not announced.

THE electric railway in Villa Borghese, Rome, has been opened by Captain Cattori, the manager. The system is on the underground conduit plan.

BOMBAY kickers are still kicking about the admission of hospital cases into the cars, and now want cars to begin running at 4:45 a. m., to accommodate early risers!

THE stirring of life in Cuba is begun. An electric tramway is projected for the town of Cienfuegos. The project has been submitted to the Minister for the Colonies, and is now under consideration by the Council of Santa Clara.

THE number of tramway bills introduced into parliament since 1884 range from thirty in that year to thirteen in 1891, with an average of twenty per annum. The length of miles proposed ranged from 173 in 1884, to 24 in 1891. From the fact that so few were built, it would seem that favorable legislative action was not easy.

THE Zeitschrift fur Kleinbahnen is the first street railway journal in Germany. It proposes to be universal in its scope, and is published by the Prussian ministry of public works. Dr. Kollman has an article on American practice in the first number. The title of the magazine literally translated means, magazine for light railways.

DURING a riot in Bombay lately, in which it was necessary to mass a few troops at a certain point, the street cars were utilized to the great convenience of the guardians of British liberty and the dismay of the rioters.

THEY WERE SCARED.

AN Italian fruit peddler recently brought a large bunch of "banans" on board an Indianapolis car. He laid the bunch on the seat, as the car was not crowded, but a little later was compelled to take it up again, to make room for another passenger. As he raised the fruit a piercing yell sounded from his next neighbor, and seven people and a little girl tried to get out of the rear door at once, all because a big, woolly tarantula had crawled on to the seat. Finally a brave man stepped on the spider, and quiet reigned once more.

## NEW PUBLICATIONS.

THE ELECTRICAL TRANSMISSION OF POWER, by Philip Atkinson, STREET RAILWAY REVIEW, Chicago. Price, \$2. The reputation of Mr. Atkinson as a writer on electrical subjects would alone be enough to secure the success of this work. It is just what a certain class of beginners has long been looking for, namely, a simple treatise on the fundamental principles of the electric motor, followed by a description of the commercial apparatus used in the electrical transmission of power.

FIRST PRINCIPLES OF ELECTRICAL ENGINEERING, by C. H. W. Biggs. Biggs & Company, 139 Salsbury Court, Fleet street, London, E. C. Price, \$0.60. This is a new edition of a very thorough work, by the editor of the London Electrical Engineer. It has been partly rewritten and extended, and treats the first mathematical principles very fully.

AERONAUTICS, the new paper brought forth by the congress on that subject, last summer, contains in its January issue, an interesting paper by Professor Langley, of the Smithsonian Institute, on "Aerial Navigation."

CASSIER'S MAGAZINE, for January, has two very sensible articles on the commercial element in engineering. One entitled "Engineering Economics," shows that the element of relative cost is the one that must oftenest be solved by the engineer of today. The other, dealing with "The Commercial Element in Technical Education," shows that it is as necessary for the engineering graduate to know prices as to know the higher mathematics.

ONE HUNDRED CITIES AND TOWNS WANTING INDUSTRIES, is the title of a pamphlet published by the Illinois Central Railroad. Those looking for a manufacturing site would do well to investigate.

THE MCGUIRE MANUFACTURING COMPANY have issued a neat 60 page book of testimonials, containing a fine half-tone engraving of cars on their trucks on the road from which each testimonial comes. It also gives a list of the McGuire patrons, and a short description of the different styles of trucks.

THE OSBORNE MANUFACTURING COMPANY have just issued a neat 26 page catalog of their steel wire brushes and brooms.

FISH BROS., Racine, Wis., are out with a handsome annual catalog, which shows their tower wagon for electric railways.

STANDARD TABLES FOR ELECTRIC WIREMEN, by Chas. M. Davis. Revised by W. D. Weaver. W. J. Johnston Company, Times Building, New York. Price, \$1. The third edition of this popular work was exhausted within a few months, and the fourth and present edition was delayed that it might contain the latest revision of the insurance rules of the Underwriter's International Electric Association.

SECRETARY RICHARDSON has issued the Association Law Reports, Numbers 7 and 8, Volume X, giving opinions in the cases of Harry Benton against the Baltimore Traction Company, and William H. Owens against the People's Passenger Railway Company.

THE tired business and professional man turns to such a number as Lippincott's January, with positive pleasure and relief. No labored philosophical articles to tax his brain, but pleasurable romance of a high order, in which he forgets the day's cares, and turns the last page with regret, to rise rested and refreshed.

PICTURES FROM NATURE AND LIFE. Poems, by Kate Raworth Holmes. A. C. McClurg & Company. Price, \$2.50. It would be hard to find a more attractive book than this, in which the delicate sentiment of the verse is matched by the unusual illustrations. The opening poem is one of those delightful, sunshiny reminiscences, whose romance sung in musical numbers, haunts the memory like a chapter from one's own experience. The other poems are all in keeping with this, and are unusually happy in mood and expression.

THE superintendent of the Marquette, Mich., Street Railway, after Monday's storm, said: "If Job had attempted to run a street railway up here during the winter, his book would never have been written."

## RAILWAY EQUIPMENT COMPANY ASSIGNS.

The Railway Equipment, Chicago, made an assignment January 3, to George O. Fairbanks. The liabilities are placed at \$30,000 and the assets at \$50,000. The company have from the start handled a very large trade in railway supplies, and its friends will learn of its embarrassment with regret, and hope for a speedy solution of its difficulties. The expectation is to resume very soon.

A GALESBURG, Ill., motorman, who says he doesn't drink, has had a hard time of it lately from queer sights on his last trip, which ends at midnight. At a certain point of the line a black calf appears, seemingly out of the ground, and keeps just ahead of the car, whether going fast or slow. The electricity twister says he'll kill that calf or throw up his job.

THE West End, of Boston, on its Ashmont & Milton branch, which crosses several wide steam road tracks, requires the conductors to light the electric lights in the car, as an additional safeguard. The operation is said to have saved several accidents, as the most careless conductor can keep watch for failure of current by that means.

SAN FRANCISCO street railways have, since 1889, been compelled to pay 2 per cent of their gross receipts to the city. The Metropolitan Electric and the San Mateo lines have not done this and \$10,000 is now due the city from them.

PASSENGERS for Boston who take the steamers of the Norwich Line are not subjected to any delay on account of rough weather, as the route of these steamers lies entirely within the quiet waters of Long Island Sound.

FOR sweet charity's sake the Ft. Wayne Street Railway carried 12,393 passengers on Christmas Day, or 10,792 passengers net, and turned over \$540 to the associated charities.

THE New York & New England Railroad Company offers great inducements to all those desiring suburban homes. Low fares, rapid transit, excellent train service, it excels in all.\*

ALWAYS ask for tickets via the New York & New England Railroad. It has connections for all parts of the country, and its train service is unexcelled.

THE attraction at the Midwinter Fair, at San Francisco, to do the Ferris wheel act, is the Firth wheel, a smaller affair on the same scheme.

## Map of the United States.

A large handsome map of the United States, mounted and suitable for office or home use, is issued by the Burlington Route. Copies will be mailed to any address on receipt of fifteen cents in postage, by P. S. Eustis, Gen'l Pass. Agent, C. B. & Q. R. R., Chicago, Ill.





WINDSOR & KENFIELD,

PUBLISHERS AND PROPRIETORS,

269 DEARBORN ST., - - - CHICAGO.

Published on the 15th of each month.

SUBSCRIPTION, - - - TWO DOLLARS.

FOREIGN SUBSCRIPTION, - - - 20 SHILLINGS.

Address all Communications and Remittances to THE STREET RAILWAY REVIEW,  
269 Dearborn Street, Chicago.

H. H. WINDSOR,  
Editor.

F. S. KENFIELD,  
Business Manager.

### CORRESPONDENCE.

We cordially invite correspondence on all subjects of interest to those engaged in any branch of Street Railway work, and will gratefully appreciate any marked copies of papers or news items our street railway friends may send us, pertaining either to companies or officers. Address:

THE STREET RAILWAY REVIEW

269 Dearborn Street, Chicago

Eastern Office, Room 14, No. 126 Liberty Street, New York.

This paper member Chicago Publishers' Association.

Entered at the Post Office at Chicago as Second Class Matter.

VOL. 4.

FEBRUARY 15, 1894.

NO. 2

THE longest and hardest contested strike in several months has been settled at Bridgeport, Conn. Both sides made concessions.

THE "trolley howl" has nearly howled itself out and almost all the decent dailies, which have been arrayed against progress, are heartily ashamed of themselves and have changed front.

THE commissioners of the District of Columbia, in their new "Model Railway" bill, have the fairness to insert a protective clause, which makes the willful blockading of street railway tracks or injury to company's property or passengers punishable with a fine of from twenty-five to one hundred dollars.

A LEADING evening paper of this city advocates at considerable length the construction in Chicago of the Greathead underground system of London. Underground transit in this town has been pretty thoroughly thrashed out, and it is safe to say will not come in the next fifty years at least. The London underground referred to is neither a public or financial success.

THE recent annual report of the labor commissioner of the state of Missouri, shows the interesting fact that the wages paid street railway employes during 1893 amounted to 41.20 per cent of the gross earnings, or the

sum of \$2,872,893. This is for employes only, and does not include salaries of officers, who received 3.23 per cent. or \$107,950. After paying for wages, salaries and improvements, the stockholder has 8.62 per cent of earnings out of which to pay interest on bonded debt and declare dividends.

THE franchise to the electric roads in Brooklyn stipulate a speed not in excess of ten miles an hour. While there have been numerous accidents there, many of them are directly traceable to a lack of reasonable care on the part of the public. Mayor Schieren has instructed the police department to admonish all motormen palpably violating this condition, and where disregarded to report the car number. The police have no authority to make arrests for high speed running and are posing very much in the attitude of scare-crows.

AN interesting decision comes from the Supreme Court of Georgia. The corporate limits of the town of Rome were extended so as to take in a bridge which had been built by the county. The street railway thereupon obtained permission from both town and county to lay its tracks over this bridge. A flood carried the bridge away, which the county replaced, but on its completion demanded compensation of the railway before allowing rails to be laid thereon, and sought an injunction against the company. The court holds that the bridge had become a part of the street, and its destruction and reconstruction does not dispossess the company of the rights enjoyed by it prior to and at the time of the accident.

ONE of the most important contracts ever let, as far as the street railway industry at large is concerned, has been closed by the Baden Railway of St. Louis, an extension of the Broadway cable, which is to be changed from horses to electricity next spring. The contract calls for welding the joints of three and a half miles of double track. The line is almost straight, and it is the intention to make each rail perfectly continuous for the three and a half miles. This is to be practically the first fair trial given the continuous rail, and the results will be of immense importance to the business. Much has been learned from the experience gained in welding track on the West End, at Boston, last summer, and the fact that the welding company guarantees no trouble from breaking at the welds, is indication that the minor difficulties developed in the first welding at Boston have been overcome. If this is the case, the sole question at issue is as to whether the factor of expansion will make trouble. This experiment has everything in its favor, as the track is to be laid new, and hence the joints have not been pounded low, as was the case on the West End. A year from now it will probably be definitely determined whether the continuous rail is a success on an ordinary street railway track. It is to be earnestly hoped that it will, and all will be glad that the experiment is to be tried. Even if this case should be a failure, it is possible that a

modification of present tie fastenings would make it successful. The current (300 amperes at 500 volts) is to be furnished by the railway company.

IN the matter of the unprecedented prize offer of the Metropolitan Company of New York, some anti-electric inventors claim to think it was only a scheme to unfairly force a recognition of the trolley, and that those who offered the alluring prize have or had no expectation of being called on to ever pay over the amount. We are disposed to accept the offer as made in good faith, and certainly the Metropolitan officials have acted in a perfectly fair and impartial manner, having entirely placed out of their own hands any voice in the selection of the better system, should there be any such named. From a purely business standpoint the Metropolitan could not make a better investment than the paying of \$50,000 for evidence which could save them the mistaken expenditure of several hundreds of thousands. On the other hand, the prize is of sufficient size to preclude the sneers of a prejudiced press and public, which have been decrying the trolley and lauding this method and that, of which they know practically nothing, to the skies. It is a great day for the crank inventor who is thus privileged to enter the conspicuous circle of public attention, who would otherwise never have been seen or heard outside the confines of his native Podunk; and though his name receives but a passing notice, and before the summer sun again blisters the pavement, he will have been lost in oblivion, still he will ever remain one of the sights of the village, as the man who entered for the \$50,000 prize. In these days, however, any device or system which promises the slightest hope of improvement or economy in street railway operations cannot long hide its head under a bushel, for the efforts of the technical press are indefatigable in searching out, studying and revealing the merits, good or bad, of all new inventions, and many times before the owner has any idea his secret is not his own. Hence it is hardly to be expected that any very radical departure will be evolved in this modern arena, and we predict the overhead trolley will, in this engagement at least, come out victorious.

THE assignments of subjects, and committees to report on same, at the next annual convention, have been made. As usual, the selections will be satisfactory to members, although the several failures last year occasioned considerable criticism. There are, of course, unforeseen causes which arise between the acceptance of the assignments by committees and the following meeting, and, while there were unusual demands upon the time of certain members of committees for 1893, which relieve them of blame, yet the allotted time of ten months should be all sufficient to either prepare a report or advise the secretary in season to make a new appointment. Of course, in a business which changes from day to day as rapidly as has street railroading during the past three years, a paper prepared in June might be obsolete by October. But this does not prevent the writer from an immediate

study of his subject and laying out the skeleton of his report, which is really where the most thought is required. It is an honor of which anyone may well be proud, to prepare a report for the American Street Railway Association, and it is to be hoped the gentlemen chosen this year will appreciate their obligation of the distinction extended them. The danger of a hastily prepared report was illustrated at last convention, in the case of one paper written on the train and read the following day, in which a given economy was claimed on the cost of an item at \$8,450, which a few weeks later was discovered should have read \$84,500, and which changed economy to loss. These reports are in a measure official, and, if the standard of the Association is to be maintained, must be greatly improved. The papers also should in every case be in the secretary's hands at least two weeks in advance and mailed all members. The reading of a single paper last meeting occupied nearly three hours, and there was not a man in the room, including its author, who was able to discuss it without the manuscript, there being but one copy. We insist on improvements in our roads, now let the committees make a record this year for excellence of text and promptness.

THE very radical and aggressive position assumed by fire insurance companies of late, in raising rates and in some cases refusing to write policies on electric railway property and buildings, where motors are supplied from railway circuits, has aroused action in many parts of the country. It is not at all unlikely that the underwriters may not have to live long to regret their present, in most cases, unjust discrimination. The question of mutual insurance is not a new one to the street railway fraternity. It was discussed and considered at considerable length in ante-electric railway days, but was dropped for the reason that the economy of self-insurance at that time was not sufficiently large to make it any special object. But now that insurance lines are refused and rates raised, the problem is no longer one of economy only, but becomes an actual necessity. One thing is certain, if the street railway fraternity is forced to the organization of a mutual insurance there will be no object in returning to their former customers. The American Street Railway Association is far-reaching, and a very strong organization. Its members are well acquainted each with the other; the jealousies which existed ten years ago no longer prevail, and all the machinery is at hand to form one of the strongest combinations ever made for this purpose. That such is the trend of ideas is evidenced in the recent meeting of the Maine State Association, and the Texas Association; and it is made the special subject of consideration before the meeting of the Massachusetts State Association next month, and is also slated for a full report and recommendation by strong committees, for the annual convention of the American Street Railway Association in October. We are in almost daily receipt of correspondence from leading managers in all parts of the country on this question, and as stated, if it is found necessary in self-protection to do our own insuring, it will be

carried out on a scale so far-reaching and extensive that its results will stagger those underwriters who evidently do not realize the power of organized street railway capital. The street railway association has never failed in a single undertaking, and the men whose business sagacity and energy have accomplished financial and mechanical miracles in the development of the modern railway, will not be found very far behind the band when the procession moves toward mutual insurance.

THE Supreme Court of California has handed down a decision in which it is held that a passenger is not bound to tender the exact fare, though the tender must be a "reasonable one" and the conductor must accept such tender and furnish change to a "reasonable amount." The court goes on to hold that a five dollar gold piece tendered by a passenger who has no smaller change is such a "reasonable one," and that the passenger cannot be ejected in the event of conductor being unable to furnish change for that amount. The question naturally arises as to what the court would consider an unreasonable tender, and we draw little comfort or satisfaction from its opinion that "a hundred dollar bill for example" would be unreasonable. Well, we should say it was; or fifty, or ten, or even five. Twenty passengers is not an unusual load for a half trip in any part of the country. Suppose half of them only, were disposed to take advantage of a law making the limit five dollars, then the conductor would have to furnish forty-nine dollars and fifty cents change to those five persons. Were it possible to have him carry that amount, each conductor would require from fifty to one hundred dollars change money, and this multiplied by the number of cars on the road, instantly amounts to several thousand dollars, and on large roads to many thousands. To carry any large amount is exactly what a well-informed manager strives to avoid, for obvious reasons; while the danger of assault and robbery, especially at night and on remote runs, would be immeasurably increased. The unwritten law of custom has for years settled on two dollars as a "reasonable" limit for which change would be given on the car, and many roads carry signs in their cars announcing this fact, and it is manifestly large enough. It rarely ever occurs but that the passenger can, if he will, tender very close to the necessary amount, and where it is known that bills of denomination of five dollars or more are not changeable on the cars, the change is procured before making the trip. We regret the fact, but such, nevertheless, it is, that the dear and generally supposed to be much abused public, contains in its body politic, schools of sharks, in numbers unguessed and inconceivable. Some wear garments which bear the marks of toil, but the great working majority is composed of those who are above soiling their gloved hands with manual labor, or are mantled in seal skin, but who are not above the disgraceful petty theft of a five cent fare. Unlikely as it might seem to the general public, not a manager of a month's experience but knows full well what a horde of the genteel riders would take advantage of a law or rule making the tender

of a large bill legal; and that the attempt to ride free on a ten and twenty dollar bill would be an immense success from the standpoint of the rider. A recent New York decision is quite the opposite of the Pacific case, and holds that five dollars is unreasonable tender, and a conductor who was arrested for retaining a five dollar bill until he could reach the company's office and get change, was not only discharged, but on his own suit was allowed \$110 damages against the passenger for unlawful arrest.

### MAINE'S MEN MEET.

The First Annual Meeting of the Maine, Street Railway Association—A pleasant and Profitable Time.

The first Wednesday in February, was celebrated by the street railway men of the state of Maine, as the first annual meeting of their recently formed association.

At 2 P. M. February 7th, therefore the following gentlemen gathered at the Cumberland Club rooms, of Portland: President William Wood, president of the Portland Horse Railway Company; secretary and treasurer E. A. Newman, general manager of the Portland Horse Railroad Company; E. H. Banks, president of the Biddeford & Saco Railroad; A. P. Gerald, president of the Waterville & Fairfield Street Railway Company, and general manager of the Bath Street Railway Company; E. K. Day, general manager of the Mousam River Railroad Company, Sanford; Chas. P. Prescott, treasurer Biddeford & Saco Railway; E. T. Berry, of the Portland Street Railroad; and A. K. Baylor, visiting engineer of the railway department of the General Electric, and Fred. S. Kenfield, business manager of the STREET RAILWAY REVIEW. The latter two gentlemen were elected honorary members of the association.

Besides the pleasant acquaintances formed and fostered, committees were appointed on various subjects. After the reelection of the same officers. The two most important committees were on "Mutual Insurance" and "Taxation." The former is to consider the advisability of mutual insurance, since Maine underwriters have begun to "want the earth." It will probably result in the formation of a mutual protection scheme.

The committee on Taxation has a more difficult task, namely, to go before the legislature to arrange on a different basis, the present unjust taxation. The rate for horse road taxation was made many years ago, and finding no special act covering electric railways, the intelligent commission rated them the same as steam roads. This is manifestly unjust, as the rate of fare remains the same for electric as for horse lines. The rate for horse roads is less than one per cent, while that of the electric roads is three per cent of gross earnings. The Portland Railway Company has paid the amount of taxes due on a horse-road basis and will let the state collect the balance if it can do so.

The next meeting of the association will be held at Rockland, on the date during August, that the executive committee may see fit to place.



In Paris, the cabs and omnibusses are heated by charcoal fires. Many deaths have resulted but no legislation on the subject has been made.

HARPER & HENDERSON, consulting engineers of the Hobart Tramway Co., Tasmania, have been making a series of tests of a contract entered into with Siemens Brothers. They found that two cars with a full load of passengers attained a speed of 12 miles per hour on a level road, and 7 miles per hour on a grade of 1 to 17.

THE HAMBURG (Germany) TRAMWAY COMPANY is operating electric cars on their circular line of route, which runs round the main part of the town. The overhead system will be employed, and the installation is being carried out by the Berlin Union Company, while current will be obtained from the Hamburg establishment of Schuckert & Co.

In Bombay, tramways require to move the heterogeneous population of the Indian metropolis, 170 cars and 870 horses. The horses are half Asiatic and half Australian. The former stand the work and climate better than the Australian and are cheaper both to buy and feed, but they have not sufficient weight to start cars singly without overstraining themselves. Each horse averages  $13\frac{1}{2}$  miles a day and lasts eight years. All directions and rules in the cars are printed in three languages to accommodate patrons.

THE increase in street railway mileage in England, as compared to American industry, is but a drop in the bucket. The following table comprehends a period of fifteen years:

	1878.	1893.
Paid-up capital	£4,035,464	£13,708,349
Length of line open (miles)	269	960
Horses	9,222	30,225
Locomotives	14	563
Cars	1,124	4,098
Passengers carried	146,001,223	598,289,509
Gross receipts	1,145,465	3,606,095
Working Expenses	868,315	2,837,446
Net receipts	230,956	768,649

What might have been, had electric traction been allowed to work out the salvation of some of these awfully congested districts of the larger cities may only be understood by those cognizant of the blessings of the trolley in America.

He fell from off the Broadway car  
At her feet, but said; "Madam,  
Excuse me, as I came this way  
I must be your cablegram."

## HIGH VS. LOW SPEED ENGINES FOR RAILWAY WORK.

We are in receipt of a letter from President Green, of the Altoona Manufacturing Company, builders of the M. A. Green automatic cut off engines, which is as follows:

ALTOONA, PA., Feb. 6, 1894.

Editor Street Railway Review, Chicago, Ill.

DEAR SIR:—I see on page 789 in your December (1893) issue, an article headed "The Experience of a Superintendent of Street Railways." In his statement he says that any engine running over 120 revolutions per minute should not be used for street railway purposes. Now, if Mr. Young is right, that a slow speed engine will stand the sudden shocks and changes of load better than a high-speed engine, then up to this time science has been a failure. I would like to ask Mr. Young, through your paper, what roads he has superintended, how many in his life time he has had charge of (of both slow and high-speed engines) and the makers of the engines; also, why a slow-speed engine is better for railway work than a high-speed engine. He must remember that in making such an assertion the public will expect him to give his theory and data for same. I would be very much pleased if he will answer through your paper.

Hoping to receive same, I remain yours truly,

M. A. GREEN, President.

DANIEL S. REGAN, of San Francisco, has invented a gas motor for street railway work which is being tried on the lines of the Market street system for service in hauling the owl cars. It is said to mount 10 per cent grades with ease, and to be very economical and powerful in its operation.

THE suit of Professor Rowland, of Johns Hopkins University, against the Cataract Construction Company, of Niagara Falls, for \$30,000 for services in connection with the design of plant, has been decided for the professor. The jury awarded him \$9,000, including \$3,500 already paid him. The charge to the jury lasted an hour and a half, and the jury deliberated the same length of time.

SAN FRANCISCO'S electrical interests are now being augmented by the building of the City railway line on Mission street. Twenty cars are built, local establishments doing the work, and the line will be operated April 1. The consent of property owners has been secured, and it is expected that the mayor's opposition to overhead wires will be shortly overcome. The cars bear the legend: "Twenty-ninth Street to the County Line." The car-house has been built and all the electrical equipment is ready.

THE changes in the personnel of the Brooklyn City have been numerous in the last year. The latest changes makes W. A. H. Bogardus, who has been secretary of the Brooklyn City Railroad for a year, general manager, owing to the increase in the number of lines caused by recent consolidations, and Cyrus P. Smith will succeed him as secretary. There will be two superintendents instead of one, hereafter. Superintendent Cameron will have charge of the lines in the central and southern parts of the city, and William Morrison, who has been superintendent of horses, will have charge of the eastern district lines.

## HALF FARES.

Interesting Facts from all parts of the Country, Boiled Down for Busy Readers.

THE Baltimore Traction Company refuses to pay a real estate tax upon its tracks in the public streets of that city.

THE Denver Tramway Company is chartering special cars for funeral parties, the casket being carried in a hearse.

THE Consolidated Traction Company of Jersey City has ruled that all mail carriers must hereafter pay fare on all lines.

MANY street railways are hauling laborers free to and from the work given them by the city. At Indianapolis, 100 men a day are taken six or eight miles.

OREGON CITY, Ore., protests against the East Side Railway Company of Portland carrying freight. An ordinance placing a license on every freight car has been passed.

ON account of the depressed conditions of general business in Boston, the West End street railway directorate reports a resolution to reduce the regular dividends from eight per cent to six.

THE Columbia & Donegal Electric Railway was formally opened January 3, by President William B. Given and a party of distinguished guests. The trip ended with a proper banquet for twenty-three.

"TROLLEY FOOT" is the name of a trouble that affects the new motorman, who rings the gong with one foot continually. It results in nothing more than lameness, for a few days, but it is nevertheless "trolley foot."



RUINS OF CAR HOUSE—SAVANNAH ELECTRIC RAILWAY.

ONE, Antonio Delatorre, an Italian, of San Francisco, is the latest discoverer of perpetual motion. Antonio's scheme is a feather spring motor actuated by weights.

RESIDENTS of Sussex street, Ottawa, Canada, publicly thank the street railway company for keeping the street in such good order during the winter. *Mirabile dictu!*

THE Brainerd, Minn., Street Railway Company, has a home made snow plow, the invention of Superintendent F. S. Parker, that is said to be both effective and handsome.

A SCHEME is on foot to build an electric railway to connect the town of Manassas to the battle field of Bull Run. A charter is applied for to the Virginia legislature.

THE Winnipeg (Man.) Electric Street Railway will reduce its fare to two cents a trip, or twelve tickets for twenty-five cents. It is a case of two roads each trying to knife the other. The competing road has reduced fares to one cent.

MANUFACTURERS of steel rails, says the Iron Age, held prices steadily at \$30 per ton until November, when they fell to \$28, and in December were cut to \$25. Average price for the year was \$29.50 against \$31.17 for 1892, \$31 in 1891, and \$34.50 in 1890.

WHILE a crowd was watching sixteen horses pulling a spool of cable up Market street, in New York City, recently, the truck broke and fifty-one tons of cable was spilled into the street. A panic ensued and the crowd scattered materially. The rope was 22,000 feet in length.

## FROM CABLE TO ELECTRICITY.

One section of the Piedmont cable road in Oakland Cal., will soon be changed to electricity. The road is in a receiver's hands, and the consent of both court and stockholders will have to be secured, but it is not anticipated any trouble will be found in obtaining the necessary authority, as the line carries a business whose volume hardly warrants cable operation. Then, too, the electric lines which parallel the cable can operate at a much higher speed, which has seriously cut into the revenue of the cable line. The section operating over the Piedmont hills has heavy grades and here the cable will not be abandoned. Electric power will be generated at the cable station, and can be installed at no very great expense.

## LIGHT THAT FAILED.

There is one young couple down in Tennessee that has been well but severely schooled in the uses of electric light. They had been married but a few days and one of their first experiences was a ride on the electric railway of their native town together, in the capacity of husband and wife. It was in the evening, and it happened that several acquaintances sat on the opposite side of the vehicle. Everything went quietly enough until at a bridge approach the trolley wheel was pulled from the wire and the electric lights in the car went out with a suddenness that would have startled ordinary people, but when a second later the pole struck the wire the brilliant incandescents showed his arm around her neck and a bright red spot on her near cheek, where a great big smacky kiss had struck her. And they don't try to kiss each other any more on the electric cars, even if the lights do go out.

THE Picayune, of New Orleans, in its issue of February 5, says of the REVIEW: "STREET RAILWAY REVIEW for January is stuffed full of all sorts of information on all sorts of subjects connected with its field, and with a large number of fine illustrations. If one want to keep up with the procession of improvement and invention in this line, he cannot do it better than by reading this charming magazine. It has it all." Coming from the most discriminating journal of the South, we appreciate the compliment,

## PLEASURE RESORTS AND CREATED TRAVEL.

Lincoln Park as a Summer Resort—Some of the Attractions.

## PART III.

The park system of Chicago, extensive and beautiful as it is, has an added charm from the wide and generous policy pursued by the management of the Park Commissioners. Chicago parks are essentially the people's play ground, and, excepting Paris, there is probably no city in the world where the privileges are better appreciated by the world's workers. These breathing spaces become every Sunday one great mall, wherein the tired shopmen, saleswomen, and artisans may breathe air untainted, and look upward to something besides heavy rafters or dirty skylight. Mothers with their children, whole families of from four to a dozen individuals, pour forth on holidays and Sundays, to sprawl on the grass or sit on the numerous rustic seats, listening to the best of music from some well known band or orchestra. The little groves are alive with children, and shady walks, more or less frequented, give Mary and John a chance to carry on their love making with some degree of comfort. The heterogeneous Chicago foreign population is always spread out here on Sundays, one vast sociological panorama. The Italians come with great baskets full of spaghetti and jugs of cheap wine; the Germans bring cables of wienewurst and bales of sauerkraut; the Bohemians, Poles, Scandinavians, "bond and free," all provided with viands of their own peculiar national taste, make up the rest of the array. These foreigners are the earliest on the ground, often filling the last trip of the owl car with their gustatory conglomeration, and the conductor's sense of smell with woe. They are there for the day, and camp down on the green sward, tether the children, and light the cigarette or pipe, as national custom bids.

As the day advances the crowd grows denser. By three in the afternoon every available seat is filled, and the endless line of vehicles is at full tide around the beautiful drives. Coupes, broughams, family carriages, phaetons, omnibusses, delivery wagons, bicycles, baby carriages—every conceivable carry-all, except wheel-



barrows, assist the street railways in carrying the crowds. To Lincoln Park, which is, without doubt, the most interesting in the city, the most Sunday and holiday traffic comes. Situated on the lake shore, two and a quarter miles from the post office, it is reached from all quarters of the North, Northwest and far Northern city, by lines of the North Chicago Street Railroad Company.

The sketch map shown gives the general location of the park, north of North avenue and south of Diversey

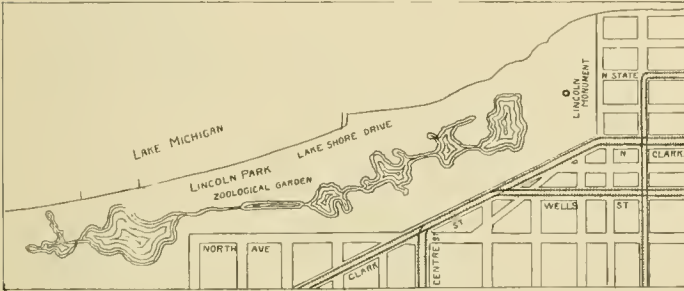

street, skirting the Lake shore. The feeding lines of Chicago avenue, State street, Evanston, Limits horse cars, and several lines connecting are not shown, but all passengers to the park must finally take the cars on the lines marked.

The increase in traffic on Sunday consequent on the attractions at the park during the summer months is from 30 to 40 per cent, and appreciable even with the tremendous daily traffic of these great arteries. On the nights of

Yerkes has brought into the coffers of the company many thousands of dollars.

The menagerie indicated on the map is one of the best zoological collections in the county, and is constantly being added to by the liberality of the park commission. Many monuments and groups of statuary decorate the



LINCOLN PARK IN WINTER.

grounds, and whatever may be said of them from an artistic standpoint, they certainly attract great attention. The magnificent Grant monument, and the truly imposing bronze of Abraham Lincoln, are the most noted. The floral attractions, hot houses, and ponds full of aquatic treasures, at the north center of the park, are very popular. The new Chicago Academy of Sciences, and the proposed improvements in other directions, will still more induce next year's traffic. The boats on the various lagoons in summer, and the Daily News Sanitarium for poor children, bring many to the park who would not otherwise come. Skating is the main attraction in winter.

The day the Grant monument was unveiled, the North Chicago Railroad Company carried 253,379 persons. The day before Chicago Day, October 8, 1893, 326,876 people saw Lincoln Park.



GLIMPSES OF LINCOLN PARK.

the week that the Yerkes electric fountain plays, it is estimated that forty to sixty thousand people are gathered at the park. The "fountain nights," from June to October, are Mondays, Wednesdays and Fridays, and the display lasts from seven to nine o'clock. Aside from the philanthropy, the beautiful, costly and tasteful gift of Mr.

THE City Railway of Richmond, Va., has had a pole cut from the swamps for a mast in the erection of its power house smoke stack. The pole in question is 85 feet in length, measures 29 inches at the base, and 11 inches at the top. It required the combined efforts of eight men and twelve mules to safely carry this large piece of timber over the rough roads and land it where it was used in raising a smoke stack, which will be 5 feet in diameter and 120 feet in height and weighing eight tons. This is one of the largest in state, and is a very handsome piece of work.

## PERSONAL.

PRESIDENT D. G. HAMILTON, of the National Railway Company is on a two months trip to Egypt,

BENJ. SIBERT, for twenty years superintendent of the Jacksonville (Ill.) street railway has resigned.

JOHN J. NASH, formerly of the cable service of the West Chicago Company, has taken charge of the Olive street cable at St Louis,

ALBERT J. ELIAS, president of the Third Avenue, has been appointed by Mayor Gilroy as member of the board of education, vice Adolph L. Sanger, deceased.

WILBUR F. DAVIDSON, the electrician hurt last year on the Illinois Central Railway, has gained \$43,000 damages against the railroad. He sued for \$100,000.

CARLTON B. TARBELL, shipping clerk for the Northwest General Electric Company at St. Paul, and his wife, were overcome by fumes of a gas stove, both dying.

JOHN PIERCE, of the Sioux City Street Railway Company was a January visitor in Chicago, making contracts for the change of the Sioux City cable line to electric.

PROFESSOR EDWIN J. HOUSTON, has long been a lay preacher, active in church work. He received the honorary degree of Doctor of Divinity last May, at Princeton.

EDWARD E. HIGGINS, well known to the railway fraternity, is settled at 26 Courtlandt street, New York City, as "Expert in Street Railway Values and Economics."

PRESIDENT WILLIAM A. MCGUIRE, of the McGuire Manufacturing Co., is absent on a six-weeks western tour and Midwinter fair visit. Mrs. and Miss McGuire accompanied him.

I. D. BARTON, formerly superintendent of the Long Island Railroad, has been chosen superintendent of the Brooklyn Elevated system by the directors, and at once accepted the place.

ROBERT S. GOFF, treasurer, and John H. Bowker, superintendent, of the Globe Street Railway Company, of Fall River, Mass., were presented with a meerscham pipe and a cigar holder by their employes not long ago.

R. C. CRAWFORD, secretary and treasurer of the West Chicago Street Railroad Company for the past seven years, has resigned to go into the brokerage business for himself. George Yuille is his successor. Mr. Yuille has been connected for many years with the Chicago Gas Company and used to corporation business in all details. Mr. Crawford will leave soon for a five months' stay in California. The street railway men of the country will miss Mr. Crawford from their circles.

W. C. BAKER, the famous Baker Car Stove inventor, said in a recent interview that the late A. B. Pullman was the originator of the idea which was afterwards carried out by Mr. Baker's ingenuity. His car heater for street railways is also becoming well known.

SUPERINTENDENT STONE of the Quincy (Ill.) Street Railway Company, had a post-mortem examination held on a horse that was supposed to have been killed by the current of his line. The veterinary surgeon found that the animal had died of a ruptured blood vessel.

MOODY BOYNTON has carried the war into Canada. A. Sydney, N. B., law firm, of which Mr. Gillies, M. P. for Richmond, is the head, applies for the incorporation of the Boynton Bicycle Electric Railway Company, of Canada, to run from Winnipeg, N. S. to Louisborg, N. S.

F. S. TERRY, well known as the former manager of the Ansonia Electric Company, has severed his connection with that establishment and has accepted the secretaryship of the Star Electric Lamp Company, whose new lamp we mention elsewhere. Mr. Terry will devote all his time to his new duties.

W. S. JEWELL, formerly of the Indianapolis Street Railway Company, has accepted a position under Manager Albion E. Lang, of the Toledo (O.) Consolidated Street Railway Company. Mr. Jewell's complete experience in street railway work is well known, and his new connection will be as happy as it is deserved.

CHARLES A. JOHNSON, formerly head of the banking house of Johnson, Kelley & Miller, Wall street, has opened offices at 80 Broadway, and will devote his time exclusively to street railway securities. Mr. Johnson is president of several street railways in New Jersey, and thoroughly familiar with street railway values.

C. P. YOUNG, the efficient superintendent of the Chattanooga Electric Railway, resigned February 1st. The Times says: "Mrs. Young is a cultured woman, who will be much missed from Chattanooga society and her husband will be a loss to its business and social world. Mrs. Young will spend some time in Washington, before joining her husband in New York."

THOMAS J. DURNIN, secretary and manager of the West Side Railway, of Milwaukee, until its recent consolidation with the Villard system, was the recipient upon his retirement, of a handsome gold watch, chain and charm, from his former employes. Mr. Durnin has held every position in the office, from office boy to manager and although flattering offers are made him in other circles it is hoped that he may remain in the street railway field, but for the present his health will not permit it. The good wishes of all his friends accompany him on his present well earned vacation.



**THE HAIGHT & CLARK SLEET TROLLEY.**

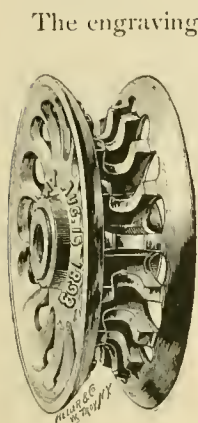

The engraving of the sleet cutting trolley wheel herewith presented shows better than words, the construction and action of this wheel, which is made by Haight & Clark of Albany, N. Y. It is somewhat similar to the Sturges wheel described in our columns last winter. It is simply a wheel having spokes with a groove which nearly fits the wire. The sleet is cut and broken by the shoulders on the edges of the groove.

It has been tried and not found wanting on a number of roads.

**EAST BROADWAY AND BATTERY ELECTION.**

At the election January 9, 1894, for directors of the Dry Dock, East Broadway & Battery Railway Company, of New York City, the "opposition" ticket comprising the following named gentlemen was elected: Richard Kelly, George H. Prentiss, A. S. Rosenbaum, Simon Danzig, Solomon Mehrbach, John H. Waydell, Henry Steers, E. W. Sumner, Marshall S. Driggs, W. Lansing Zabriskie, Henry A. Morgan, M. Feuchtwanger and John Bryns.

At the meeting of the newly elected board of directors on January 10, Richard Kelly was elected president, John Bryns, treasurer, and E. T. Landon, secretary. Mr. Kelly has been secretary and treasurer of the company for about twenty-five years, resigning from that office last May, when John Bryns was elected to fill the vacancy. Mr. Bryns has been a director for the past ten years. E. T. Landon, the secretary, has been connected with the company for the past twenty-one years as its book-keeper, and for the past ten years as auditor.

**UNCLE SAM'S MODEL RAILROAD BILL.**

The Commissioners of the District of Columbia have completed what they term a "model bill" for the regulation of street railroads in the District. It is not quite as unreasonable as would be expected—coming from that source, but it has restrictions enough, so that the building of electric lines will probably not be very active under it. Half the cost of widening the street for railroad purposes is to be charged to the railroad, and where a highway is less than sixty-six feet wide, the railway must be built entirely outside the highway. The space between, and two feet each side of the tracks must be kept in good condition as the Commissioners may direct. Companies using overhead wires must maintain such lights along their routes as the Commissioners require, without cost to the District. No overhead wires are to be allowed within the city limits. The District may at any time change the grade of any streets, and the railway must change its grade to

correspond. Any motive power but steam may be used. Permission is kindly granted to erect power houses along the routes, but said power houses must be completed in a time specified. Numerous other details in the organization of the companies and their method of doing business are required. Every subscriber to stock must pay five per cent at the time of subscribing.

**TICKETS AND TRANSFERS AT MELBOURNE.**

The Melbourne Tramway & Omnibus Company is laboring under the double disadvantage of hard times and the keen competition of cable and suburban railways. It therefore finds it necessary to try every practicable

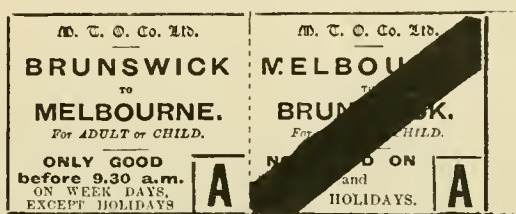

plan to induce traffic. To meet competition on one of its lines, round trip tickets have been issued, which are good going before 9 a. m. and returning at any time during the day. This proved to be a good move. The price

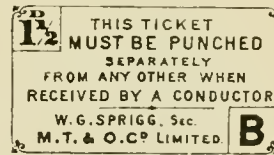

of these tickets is 6 cents. Another plan is to sell 8-cent tickets on an omnibus feeding line, which are good for the whole distance. These tickets are sold by the bus drivers, who tear off a coupon from each ticket. The drivers deposit these coupons in the fare boxes which are on each bus. Thus the fare box acts as a fare register. The passenger is, of course, given the other half of the ticket, which is used to pay his fare on the cable train. In going the other way, the passenger pays 6 cents in the car and is given the transfer, which, with 2 cents ("one penny"), is accepted as his fare on the omnibus. To induce riding on the part of the business men and workmen, "city tickets" are issued. These are sold for 3 cents, and are good within a space of about one square mile in the business part of the city only.

It is claimed that the law requiring Minnesota street cars to be vestibuled is unconstitutional.

## KNOXVILLE'S SUSPENDED RAILWAY.

Three Hundred and Fifty Feet Above the Water;—More Hair-Lifting Than the Ferris Wheel.

Although aerial rope tramways have been extensively exploited for light work, it is with something of a start that one learns first of the suspended railway when erected for such heavy work as the one now spanning the Tennessee River at Knoxville. Perhaps few of the novel schemes outlined from month to month in the REVIEW have more suggestion in them than this. The line is the property of the Unaka Park Company, and, besides being a feature which in itself attracts many people, it furnishes means of transportation to a beautiful pleasure resort.

engraving. These timbers are 14 feet long, and are placed behind partitions of 6-foot plank. The connecting bars are 12 feet long and  $1\frac{1}{4}$  inch thick. The staples to which the cables are fastened have 24 inches of threads to take up slack. The cable furnishing the motive power is  $\frac{1}{2}$  inch in diameter and is permanently fastened to the car. The anchor at the upper end consists of iron plates fixed in the rock. The supporting cables each have a breaking strain of 60 tons. The power is furnished by two 20-horse-power engines in the power house at the lower end. The car empty, weighs only 1,200 pounds. It has a 14-foot body and 3-foot platforms, and is 6 feet wide, by  $6\frac{1}{2}$  feet high. The seating capacity is sixteen passengers but more are often carried. The up trip takes about three and a half min-



Taking a West End car in the center of Knoxville, the visitor is carried to within a five minutes' walk of the depot at the lower end of the bridge (by which name the inventor calls his device), at which place is also the bridge power station. From here stretch upward two  $1\frac{3}{8}$ -inch cables to the top of the opposite bluff, 350 feet above the starting point, the length of the span being 1,060 feet. In other words, the grade is about 33 per cent. Before getting aboard, the careful man naturally wishes to know something about the strength of the affair, and what are the probabilities of his taking a deep dive in the Tennessee River before reaching the top. The two  $1\frac{3}{8}$ -inch cables which compose the rails of this system, are anchored at the lower or Knoxville side, by bolting to 12 by 12 inch oak timbers, as shown in the

utes. The descent is made in half a minute by gravity.

Once at the top the passenger has the freedom of Unaka Park, a romantic spot of ground commanding a magnificent view of the surrounding country. In fact, the owners of the property, who also own the "cable road" and collect the toll of five cents for crossing their bridge, had very little to do to make the park attractive. About 50 feet from the summit is one of the peculiarities of this region, namely, a "blowing cave" where cold air is continually emitted. The hills in the vicinity are honeycombed with caves. Longstreet Heights, as this mountain is called, is famous, not only as the one presenting the best view of the surrounding country and mountain ranges, but has become one of the classic spots of the late war. Thirty-nine of General Long-

street's rifle pits are still to be seen on the mountain side. The Unaka Park Company owns 133 acres on the mountain, over all of which cool spring water is piped. This water is elevated by a hydraulic ram, the source being a spring on the premises.

Certainly if any road has a right to be called a cable road this does, as the rails, roadbed and motive power

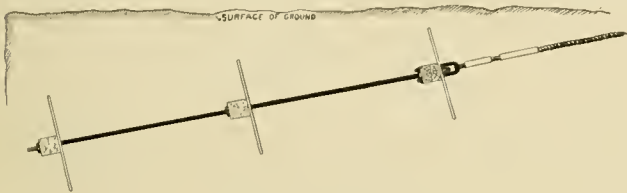

SIDE VIEW OF ANCHOR.

are all cables. The car is provided with automatic brakes, which stop the car in case the propelling cable breaks or slips on the drum.

On this cable road there are no low joints to threaten the sanity of the manager, nor is there dirt on the track to rattle the sashes. As a consequence, the 1,000 foot journey is a remarkably still one and the sensation almost that of the balloonist. As a matter of course the visitor feels a little shaky when swung off into space at a height

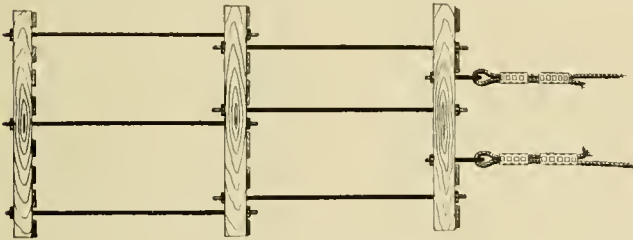

PLAN OF ANCHOR.

of 350 feet, but the feeling of exhilaration evidently finally overbalances this in a majority of cases, judging from the patronage of the bridge. The road started in the spring of 1891. The plans are those of B. J. Gagnier, of Detroit, to whom the patents belong. The idea commends itself to street railways as a means for providing attractions at favorable points such as exist in many places. This form of railway can be used in some places as a cheap substitute for a bridge. It does not begin to take the outlay either of time or money required to erect the ordinary bridge structures.

### A GOOD RECORD.

The York, Pa., Street Railway Company finds that rapid transit makes an emphatic difference in the receipts of the line. The last year the road was operated by horses was 1891. The year and the dollars run thus:

1889,	-	-	-	-	-	\$13,304.44
1890,	-	-	-	-	-	16,710.00
1891,	-	-	-	-	-	18,673.06
1892,	-	-	-	-	-	23,032.07
1893,	-	-	-	-	-	38,559.68

Many did not think that there was traffic to draw upon. but the figures prove the contrary.

## MOVING HOUSES OVER RAILWAY TRACKS.

Ordinances in Boston—State Law in New York.—And Individual Arrangements Which are in Vogue in Several Cities.

### PART II.

That a city ordinance can be passed to protect the rights of street railways, and that when passed it will do its work efficiently is shown in the history of house-moving in Boston. The success in that city should encourage every manager who is subject to this annoyance, to secure similar legislation in his own city. As the benefits can be shown to be so largely in the interests of the traveling public, local papers and city fathers should be interested in the merits of the measure, per se. As set forth last month, the house-moving nuisance is governed largely by the age of the city and the prevailing material used. Thus in Baltimore no difficulty is reported as one seldom sees a house moved in that city, and at Cincinnati, while no city ordinance exists to protect the companies, yet on account of the many hills upon which the city is built, troubles from this source are inconsiderable and have not called for relief measures. But in the city of

### TOPEKA

much annoyance has been experienced and as yet the city has not taken steps to protect the roads. Joseph M. Patton, general manager of the Topeka Railway Company, writes as follows:

"I can not give you much light upon this subject as we are sufferers in this city by lack of ordinance governing this matter. The only mention made in the ordinances of the city in relation to the moving of buildings is that the person moving the building must first get a permit from the chief of fire department. The chief of fire department here has held that he has no authority for refusing any one making application for the permit. The result has been that we have been repeatedly annoyed in the operation of our line by the moving of buildings across our tracks; and, in some instances, have been obliged to unhook our trolley wire from the span wires for a block each way from the intersecting street and to lay the wire on the ground to allow the building to pass over it. In such instances as this it is quite a difficult matter, and especially so with our feed wires. We have never had recourse upon the parties moving the building for expense incurred thereby.

I am exceedingly glad you have taken this matter up, and trust much benefit may result from its discussion, and if possible, by concerted action and agitation in the different cities where electric railways are operated.

It seems manifestly unjust that an individual should have the privilege of annoying a large number of other persons, passengers in the cars; and always cause great trouble and annoyance to the street railway company for the sake of their own personal gain. In Boston, I believe it has been provided by ordinance for many years that no building should be moved upon or across the tracks of

any street railway company until the consent in writing from such company had been obtained, and said certificate duly filed.

The practice of moving old and worthless buildings in western cities is a great and frequent annoyance, and in its abatement I think the telegraph, telephone and electric light companies will be nearly as much interested as the electric street railway companies.

If all interested in this matter would combine, I think the much-needed legislation might be obtained. I shall watch with much interest for the results of your agitation of this subject, and trust much benefit may be derived from it."

All who are acquainted with the extensive and magnificent system of the West End Street Railway,

BOSTON,

will readily appreciate the evils resulting from a delay of this kind in that city, where the streets are for the most part narrow and crooked, and in large districts few cross streets are available into which a building can be set during the day, with the intention of resuming the route again at night. Once started it must run its course, hence suitable restrictions have prevailed for some years there, and the result has been highly satisfactory to the public, and in fact everyone interested except the house-mover. The city ordinance of Boston provides that buildings may only be removed by permit from the superintendent of streets, when authorized by the mayor and aldermen,

"And whenever it appears that the moving of a building under the provisions of this section will encumber the tracks of any railroad shall be given by the board of aldermen upon the subject, before such permit is authorized."

This consent by the city is also made contingent upon the consent of the railroad company whose tracks it is intended to cross, and practically the same arrangement prevails in the immediate suburbs through which much of the West End system extends. This consent from the company can only be obtained after the parties desiring same have signed an agreement of which the following is a copy:

BOSTON,.....189

MR. C. S. SERGEANT,

General Manager West End Street Railway Company,  
Boston, Mass.

Dear Sir:—I desire to move.....building.....feet long,  
.....feet wide.....feet high, from.....via.....to.....  
on.....189..

In consideration of permission being granted me by your company to cross its tracks with said building, via above-named route, I hereby agree to move said building at such time of day as may be agreed upon between Division Superintendent.....and myself. I further agree, in case of detention or interruption of any of the cars or lines of your Company, to bear the full amount of expense incurred by your Company, caused by such detention and interruption, also to pay all expenses for labor and material in case it becomes necessary to cut or remove any of the wires, track or other property belonging to your Company or used by it in the operation of its cars. And I also agree to use the utmost dispatch in

removing said building from its position whereby it interferes with, or interrupts in any way, the cars or lines of your Company.

But even this agreement is not accepted without a detailed statement which General Manager Sergeant sends to each division superintendent in whose territory the building will move, and which reads thus:

BOSTON,.....189..

Mr.....Division Supt.

Dear Sir:—.....this day makes application to me for permission to move a.....building.....feet long,.....feet wide,.....feet high, from.....via.....to..... What lines will such moving interfere with?..... To what approximate expense will the Company be put to if such permission be given, and if so, upon what day and at what hour of the day will it the least inconvenience you to have such building moved?.....

Yours truly,

Div. Supt.

Gen'l Manager.

When the division superintendents have reported favorably, a moving schedule is made out for the applicants, which must be strictly observed, and when the agreement is accepted the company issues the following permit:

WEST END STREET RAILWAY COMPANY.

GENERAL MANAGER'S OFFICE,

81 MILK STREET.

BOSTON,.....189..

Your permission from this Company to move a building from.....via.....to..... provided such moving is done in strict accordance with your agreement with me, dated..... 189.. and agreement with..... Division Superintendent, dated..... 189.. copies attached hereto.

Under this system complications, expense and delays have been reduced to a minimum, and while none of the rights of the house-mover—if he has any—are lost, he is made responsible for expenses which but for him would never have occurred, and what is quite as important, for the loss of revenue from travel, which by his obstruction the company is prevented from earning.

As far back as the '70's, house-moving in

BROOKLYN

became so frequent as to very seriously interfere with the operation of the horse cars, and at the solicitation of the late William Richardson, the matter was made the subject of legislative enactment, the bill reading as follows:

CHAPTER 764.

An Act to prevent obstruction to travel in the city of Brooklyn, passed April 26, 1871.

SECTION 1. It shall not be lawful for any person to move any building of any description through or on any street in the city of Brooklyn which has a railroad track laid thereon, unless the same is done in such a manner that cars running on said track are not obstructed thereby.

SEC. 2. In case any building is moved across the tracks of any railroad, the same shall only be done between the hours of eleven o'clock at night and three o'clock in the morning.

W. J. Richardson, secretary of the Atlantic Avenue road, says:

"You will see that the operation of the road is interfered with as little as possible, and we have sometimes made a special arrangement for a money consideration to modify the law in an individual case, but it is unusual. House-movers are very careful to notify us of an intention to cross our tracks and are very certain to make sure that they will not transgress the law. We have had no case of the moving of a house across our tracks since the road has been operated by the overhead system of electricity. Any interference so caused, such as cutting of the wires, we should expect to be recompensed for."

One of the most interesting chapters in the history of house-moving is contributed by W. S. Norman, general manager of the lighting and railway companies at

#### SPOKANE

and who relates the following experience:

"Replying to your letter of the 27th ulto., we have had a great deal of trouble in the matter of house-moving across our streets. Some four years ago a large building was moved against our lighting wires, and we got out an injunction, and succeeded in preventing the man from cutting through our lead. When our street railways were put in, an instruction was issued to the board of public works by the city council, that in case any contractor wished to move a building he must make his necessary arrangements with the company, and all house-movers now, before taking a contract to move a house, invariably figure with us and find out what it will cost them to take care of our wires, and we make them put up a deposit to take care of any damage to our property. A short time since we had a man who ignored this condition and started to pull a house across our tracks, but we prevented him from doing so by stalling a car in the vicinity, and by going before the court and asking for an injunction, whereupon he quickly conformed with the rule. We have never thoroughly thrashed out the issue in the courts, for the original suit mentioned above never came to a final hearing.

The lower court, however, held that the moving of a building on a public street was not an ordinary and legitimate use of the street, but was exceptional traffic, and such a mover had no right therefore to injure property which was being maintained in the street in conformity with the law, and in conformity with franchise passed by the city. We fought the issue out in another way with the steam railroad company, which was in the habit of running its pile driver through the city without reducing it to bridge height. They would run the pile driver at the height of 30 or 40 feet, and run through a lot of telephone lines which crossed the track, and we compelled the company to lower its pile driver to the height which it should have to be in passing under any of its own bridges.

It seems to me that the street railway people, largely to avoid hostile anti-corporation sentiment, have avoided the settlement of this question of house moving, until it has reached very large proportions, and involves a considerable expense to the companies and loss to the public. I believe that we should fight it out upon the broad principle that streets are made for public travel, and that the companies are the creatures of the public, and that their travel must not be impeded by the uses of the public streets for any other than public purposes. The removal of houses is not a public convenience, nor a public necessity, and I believe the principle of house moving has no place in the history of any other civilized country than the United States.

I hope the plan which you have started upon may lead to some concerted action on the part of the street railway men, so that we can take some one case, on its merits, to the Supreme Court, and get the entire issue adjudicated."

At New Haven, there is no ordinance, but the roads have always managed to protect themselves by friendly relations with the city officials, who decline to issue a permit until the applicant brings a consent from the manager of the line to be crossed.

#### IN CANADA

no serious trouble is reported, as in Montreal, and elsewhere, stone and brick constitute the favorite building material. Chas. E. A. Carr, of the Toronto Railway Company, reports that while there is no municipal law, the custom for years has been to secure consent of the city commissioner, who requires the applicant to stand responsible for all damage consequent on the removal, including any repairs necessary from cutting railway wires.

#### WAGES IN BOSTON.

The agreement of employes and the company in Boston has been signed, sealed and delivered for 1894. The agreement contains twenty-four articles, and is signed by President Little and General Manager Sergeant for the West End and representatives for the men.

The agreement is for not more than ten hours work in twelve. Payment of regular men at the rate of \$2.25 a day for platform work. Extra men shall be paid at the rate of 27½ cents an hour up to five hours in twelve when the rate shall be 22½ cents. Overtime by reason of accident or otherwise shall be paid at the rate of 24 cents per hour in addition to these amounts; for ten minutes or less 4 cents, for over ten and less than twenty-one 8 cents. Men doing schedule work (not to exceed 7½ hours) on night cars shall receive \$2.25. All chartered cars starting previous to 10 p. m. shall be paid 30 cents an hour. Conductors and drivers of such cars, starting after 10 p. m. and before 5 a. m., shall be paid \$1.00 for the first two hours and at the rate of 50 cents an hour thereafter. The whole agreement contains twenty-four articles.

## BY CABLE TO THE CLOUDS.

The Romantic and Scenic Cable Life Up the Stanserhorn.

Among the four beautiful mountains surrounding the Lake of the Four Cantons, within excursion distance of Lucerne, the pyramidal Stanserhorn is the most commanding. The great interest that it has always possessed is now enhanced by the ease of access to it, made possible by the opening of the Stanserhorn mountain railway during the last summer. The road leads from the neat little village of Stans (at the foot of the mountain) to the summit, 6,232 feet above sea level.

After embarking from Lucerne, a thirty minutes' steamer trip brings the visitor to Stansstadt, an ancient

turbine station at Buochs, which also furnishes power for the trolley line. Every precaution for the safety of passengers is used, including automatic track brakes, and the passengers are spared the click and rattle of a cog or rack system.

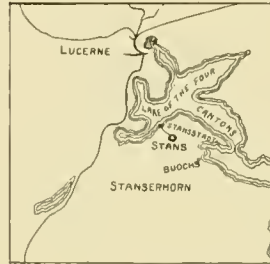

The journey up the mountain is made in three sections, the ascent occupying altogether forty-five minutes. The first section is almost in a direct line to Kalti, the first station, through green meadows to the height of

2,342 feet. Here the second section begins with a change



little place redolent with memories of Arnold von Winkelried and his brave compeers who dwelt and fought and died in the tight Canton of Unterwalden.

In the midst of these reflections the familiar buzz announces the arrival of an electric car, nay, by your leave, a trolley car, which conveys the visitor to the mountain's foot and prepares his mind for the ascent via the mountain railway.

The transfer from the trolley car to the mountain road occupies but a short time, and the traveler finds himself in an ordinary inclined-plane car in the form of a set of steps. Each step or seat is capable of accommodating eight persons or 32 to each car. The system of propulsion used is the cable, after the plan usually followed, but actuated by electricity instead of steam. One of our illustrations shows the motor and a part of the winding drum. The power for the motor comes from the central

of cars and two minutes' wait to view the landscape. Then on to the second section through a deep ravine, pine-clad and silent. Now it crosses a mountain torrent on a stone bridge, now through a cut at a grade of 60 per cent and the visitor lands at Blunatt station, in an alpine meadow 4,005 feet above the sea. Again a change of car, and the third section begins. The scenery is more rugged, and tunnels, cuts and fills, show the engineer's skill and the builder's strength. Finally the long viaduct, shown in our illustration, leads to the terminal station, Stanserhorn Hotel, 6,070 feet above the Atlantic's level. Accommodations at the hostelry for 100 guests add comfort to the tourists' thoughts of a long return and dinnerless journey. One hundred and sixty feet further by foot brings the visitor to the top point of the Stanserhorn, and there the magnificent view amply repays the journey. All about the serried ranks of the

Alps; Rigi, with its mountain railway; the Wetterhorn, the Jungfrau and the rest of the notables; toy villages in the valleys and the cities grouped on tablelands, all is stretched out, a panorama of old Helvetia, and the wonders of the railway are forgotten for a time until a sharpened appetite calls the mind from scenery to supper.

The other railroads climbing mountain peaks, mainly by rack roads, are the Rothorn, 7,386 feet; Pilatus—previously illustrated by the REVIEW—6,776; the Wengern Alp, 6,773 feet; Mount Washington, 6,293, and the Stanserhorn, 6,232. Then comes the Rigi, 5,740; Monte Generosa, 5,376; Murren Alp, 5,284; Visp-Zermatt, 5,277; Vesuvius, 3,887; San Salvatore, 2,896, and the Uetliberg, near Zurich, 2,696. Of all these the outlook from the Stanserhorn is said to be the widest and most satisfactory.

**ANNUAL REPORT OF THE CHICAGO CITY RAILWAY.**

When the record is balanced by the coming great historian of Chicago's municipal preeminence, the street railway systems of the city will get the credit for their many hard fought battles, the slogan of which has been, "the greatest good to the greatest number."

And looking at the daily press, it would seem not until then.

Ad interim, the railways go on beautifying the parks, adding to real estate values, and hauling passengers ten miles for five cents.

The Chicago City Railway, at its late meeting, of January 15, gave to the Field Columbian Museum the \$100,000 of World's Fair stock, and authorized a cash donation of half that amount if the museum remain at Jackson park. So much for the city.

The president's report gave the following results for the Columbian year of 1893:

Number of passengers carried	- - -	120,506,270
Increase over 1892	- - -	32,578,409
Total earnings	- - -	\$6,059,989
Operating expenses, 56.75 per cent of income	- - -	3,422,040
Interest	- - -	199,237
Total	- - -	\$3,621,278
Net earnings (28.69 per cent of capital)	- - -	\$2,438,711
Cash dividends paid, 24 per cent	- - -	2,100,000

As compared with 1892, it will be remembered that the net earnings were 19.01 per cent, and the dividends paid 12 per cent.

In 1893 the mileage was 26,304,090, an increase of 5,483,380, as follows:

MILEAGE.	RECEIPTS PER CAR MILE.	EXPENSE PER CAR MILE.
Cable, 19,713,610	19.965 cents	9.921 cents
Horse, 5,053,050	31.050 cents	24.863 cents
Electric, 1,537,430	34.148 cents	13.660 cents

The admirable results of electric traction are obvious. The increase in receipts per day over 1892 was \$4,494, a percentage of increase of 90.69 during the World's Fair period, and of 9.31 during the balance of the year.

The stockholders gave the directory power to issue, during 1894, at any time they saw fit, new stock to the amount of \$1,000,000.

The re-election of the old board and officers showed the high appreciation of the stockholders for the magnificent management of the Chicago City Railway during the trying period of the Columbian year.

**WILL WORK OUT ITS OWN SALVATION.**

A gentleman in an eastern city, but who is not personally interested in the road in question, said to our correspondent: "The papers here, with no exception, are simply roasting our new trolley road. It is outrageous. I have written two or three open letters to them, but they are hide-bound and will not pay any attention. To show how far they carry it: not more than ten days ago a man had both legs cut off by the cable road and they made a short paragraph of it in an out of the way corner of the paper; whereas a collision between a trolley car and a baker's wagon in which no other damage was done but to knock the wagon off the track, was given a double header on first page as a "Deadly Trolley Accident." As I wrote to the — if the editors of the papers would try to educate the public to the fact that increased rapidity of traction cars means increased watchfulness on the public's part they would soon lessen the number of accidents instead of always painting the ideal transit as a juggernaut. In the case of the accident above referred to, the motorman was ringing his bell, but the wagon was "tracking" and would not turn out. But I presume the hue and cry against the "deadly trolley" must run its course the same as all new transits, for the papers here years ago raised almost a veritable riot when horse cars replaced the old omnibuses and stage coaches. Oh, for an honest and fair treatment of the trolley, instead of the hide-bound opinioned and water-proof insulated statements of the general press."

**THE ARTESIAN WELL DISTRICT OF SOUTH DAKOTA.**

Since the publication of the article on the artesian well power of South Dakota, which appeared in our January issue, and attracted so much attention, we have received a letter from President W. M. Blackburn, of Pierre University, stating that doubtless the artesian well district extends west as far as the Rocky Mountains. The wells at Pierre and Chamberlain are in the Missouri valley, and, while no wells have as yet been sunk in the western part of the state, it is gratifying to learn from geological authorities that the area probably extends over so great a territory. South Dakota's mine is much richer than we represented.

A RECENT decision of the Supreme Court declares that the street railways of Massachusetts are responsible for accidents caused by the overhead work of their construction, and liable therefor.

## ANNUAL REPORT OF THE CITIZENS TRACTION, PITTSBURG.

A Model Statement, Containing Much Valuable Data for Reference and Comparison.

The very interesting and instructive annual report of the Citizens Traction Company, of Pittsburg, for the year ending October 31, 1893, has just been issued, and is a great credit to the management, of which John G. Holmes is president, and J. E. Rugg superintendent.

The secretary shows the total receipts from passengers to be \$707,895, with total operating expenses of \$335,979. The per cent of expenses to receipts, 74 per cent, nearly.

The superintendent reports 12,999,478 passengers carried by the cable, and 1,848,373 by the electric system, with a total car mileage of 2,037,262 for the former, and 459,223 for the latter method of traction. The per cent of receipts for operating were: For the cable, 53 per cent; for the electric cars, 68.6 per cent; average, 54.8 per cent. On the cable line the receipts were 30.80 cents per mile, and the expenses 16.33 cents, leaving a profit of 14.47 cents. On the electric system the receipts per mile were 17.51 cents, and the expenses 12.02 cents; profit, 5.49 cents. The taxes paid were:

State, \$32,471; county, \$53; city, \$7,192.

The fuel and water account of the cable power house is as follows:

Nut coal, 3,671 <sup>3</sup> / <sub>4</sub> tons, at \$1.40	\$5,220
Nut coal, 584 <sup>3</sup> / <sub>4</sub> tons, at \$1.35	789
Slack coal, 4,348 <sup>1</sup> / <sub>2</sub> tons, at \$1.03	4,479
18,784 gallons of water, at 7c. per M	1,314
Total	\$11,803

Daily expense for operating cable power house (725-horse-power) reads:

Oil, grease and waste	\$ 2.31
Fuel	28.74
Water	3.60
Labor	27.16
Total	\$61.81

Cost per horse power, 20 hours - 8.50 cents.  
 Cost per horse power per hour - .42 cents.

The electric power station required fuel and water as follows:

Nut coal, 1,067 tons, 622 lbs., at \$1.40	\$1,494
Nut coal, 254 tons, 1,210 lbs., at \$1.35	343
Slack coal, 1,332 tons, 496 lbs., at \$1.21 <sup>1</sup> / <sub>2</sub>	1,618
5,095,995 gallons water, at 7c. per M.	356
Total	\$3,813

The daily expense for 22 hours per day for 216-horse-power was:

Oil, grease and waste	\$ .56
Fuel	9.47
Water	.98
Labor	8.96
Total	\$19.97

Cost per horse power per day - 9.20 cents.  
 Cost per horse power per hour - .41 cents.

The detail of cost of motive power per car mile, for cable and electric, appears as follows:

CABLE.	ELECTRIC.
Coal.....8.45 lbs, cost $\frac{5.1}{100}$ cents	11.36 lbs, cost $\frac{8.00}{100}$ cents
Oil, waste and water.....cost $\frac{1.00}{100}$ cents	cost $\frac{1.00}{100}$ cents
Labor.....cost $\frac{4.9}{100}$ cents	cost $\frac{7.0}{100}$ cents
Total cost..... $\frac{11.0}{100}$ cents	Total cost $\frac{16.0}{100}$ cents

The daily expenses of the year averaged as follows: Pay roll, \$694, or 35.82 per cent of earnings; supplies, \$249, or 12.87 per cent of earnings; total, \$944, or 48.69 per cent of earnings. The average daily receipts were \$1,939.52.

The road equipment consists of 68 cable cars and 20 electrics, the latter equipped with two 20-horse-power motors, with the necessary accompaniments of snow sweepers, sprinkling carts, etc.

The machine shop equipment consists of 2 lathes, 2 drills, 1 boring machine, 1 slotting machine, 1 bolt cutter, 1 wheel press, emery wheels, and smaller tools.

The employes number 309, divided thus:

TRACK DEPARTMENT: 8 flagmen, 8 oilers, 2 switchmen, 2 curve sweepers, 1 wagon driver, 2 cart drivers, 1 paver, 1 rammer, 4 laborers, 1 day foreman, 1 night foreman. Total, 31.

POWER HOUSE DEPARTMENT: 4 engineers, 2 oilers, 5 firemen, 3 stokers, 4 vault men, 8 grip examiners, 1 porter. Total, 27.

MACHINE SHOP: 2 machinists, 4 jobbers, 2 blacksmiths, 2 helpers. Total, 10.

CAR REPAIR DEPARTMENT: 1 foreman, 4 carpenters, 1 blacksmith, 2 painters, 2 brake repairers, 1 scrubber. Total, 11.

STABLE DEPARTMENT: 2 hostlers, 1 watchman, 1 wagoner. Total, 4.

CAR BARN: 1 shedman, 2 watchmen, 15 car cleaners. Total, 18.

ELECTRICAL DEPARTMENT: 2 day motor and line inspectors, 2 night inspectors; total, 4. Besides these there are 20 unclassified, as follows: 1 mechanical engineer, 1 civil engineer, 1 electrician, 1 rope splicer, 2 assistant superintendents, 1 paymaster, 2 record clerks, 1 stenographer, 6 dispatchers, 2 receivers, 2 inspectors.

There are 91 conductors, 71 gripmen, and 20 motor-men.

The repair account is of great interest. The record for Nov. 1, 1892, to October 31, 1893, for electric and cable lines reads as follows:

Cost of car repairs on	
Butler street (8-wheeled cable cars)	\$5,866.35
Cost, average, per car	209.51
Cost, average, per mile	$\frac{7.3}{100}$ cents
East Liberty street (cable)	\$9,267.13
Cost, average, per car	243.87
Cost, average, per car mile	$\frac{7.5}{100}$ cents
Sharpsburg line, suburban (4-wheeled elec.)	\$1,210.05
Cost, average, per car	110.00
Cost, average, per car mile	$\frac{3.8}{100}$ cents
Frankstown line, suburban (4-wheeled elec.)	\$100.86
Cost, average, per car	40.09
Cost, average, per car mile	$\frac{2.8}{100}$ cents



A FEW FACTS ON FENDERS.

It is to be hoped that the flood of car fenders with which the patent office has been deluged will bring about more material results than the similar floodings that office has received from car couplers, car starters and alternate current motors. At present it almost seems as if managers were so dazed by the multitude of these devices that they are unable to choose any of them. In spite of this, the number of cars equipped with fenders is no doubt daily increasing. It is the purpose of the present article

which canvas is stretched. The lower pipe of the frame is covered with rubber to relieve the shock on the individual struck. It is normally held up against the dashboard and falls by its own weight when released as needed.

As might be expected, one of the biggest fool-suggestions comes from a New York daily newspaper. It is to have a foot-board and a grab-handle around the end of the car so that the person on the track could do the switch-engine-brakeman-act and quietly step onto the foot-board. It is exceedingly improbable that the people



WORKING EXHIBITION OF THE BRAGG FENDER.

to briefly describe and illustrate a few styles of fenders not before shown in our columns.

First on the program comes the Bragg fender used on the Hoosac Valley electric road. It is the invention of F. A. Bragg and T. W. Richmond, of North Adams, Mass. It consists essentially of a frame on which is stretched wire netting and has a pneumatic tire for a cushion around the

ordinarily victims of an accident would have the skill and the presence of mind necessary to use this.

Superintendent Crosby, of the Vallamont Passenger Railway, Williamsport, Pa., has put a "cow-catcher" on one of his cars. The running gear seems pretty thoroughly fenced in. The fender is carried about four inches from the track and let down by the motorman.

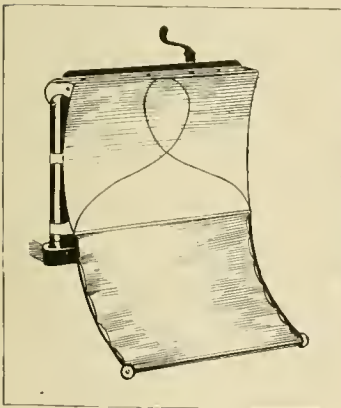

CURTIS FENDER.

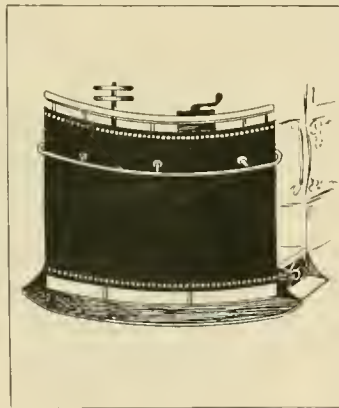

N. Y. HERALD.

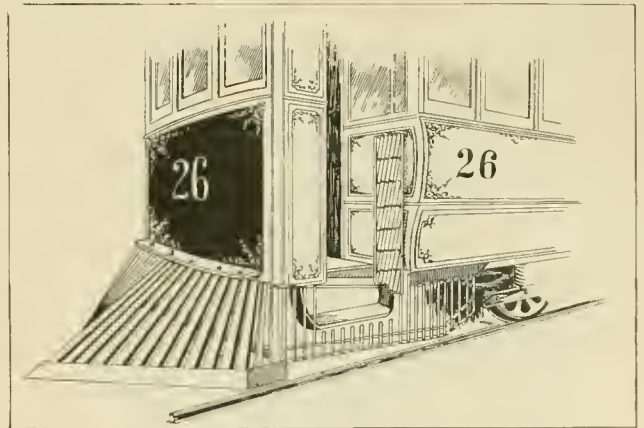

CROSBY FENDER.

front edge. In the latest form the rubber tube extends clear around to the steps and the netting covers the entire space inside. The guard is normally back under the car but is shot forward some distance when touched off by the motorman.

C. H. Curtis, of 222 Elm street, Cincinnati, has a fender consisting simply of a frame of gas pipe over

One day when Superintendent Crosby was on the car this fender had a very unexpected practical trial. A delivery wagon suddenly turned into the track and the horse was struck, its leg being broken by a twist. The fender was unscathed.

A brand new idea is that of Thomas Barnes, of 90 Graham street, Lowell, Mass. The guard is normally

as shown at the left. When anything strikes it the sides fly out, as shown at the right, and the person is pushed out of the way.

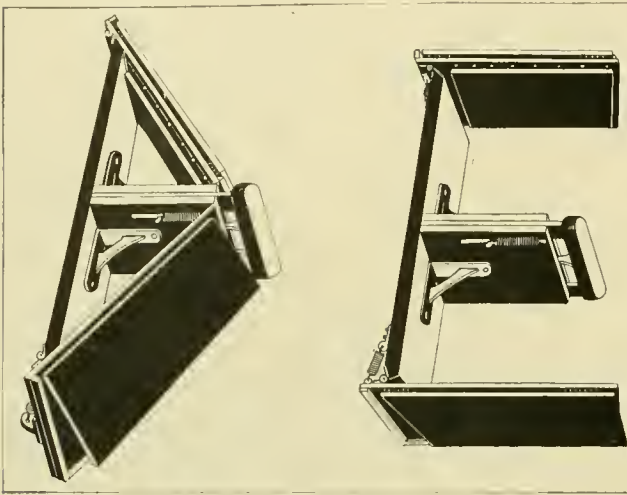

THE BARNES FENDER.

The Moore fender eliminates the uncertain "human element" in the motorman, by automatically cutting off the current and applying the brakes. The brake used is



MOORE'S METHOD.

a kind of block, which drops in front of the wheels. The whole mechanism is operated by an object striking the fender.

R. T. White's fender differs from the foregoing in that it is carried by the boxes on the car axles instead of being

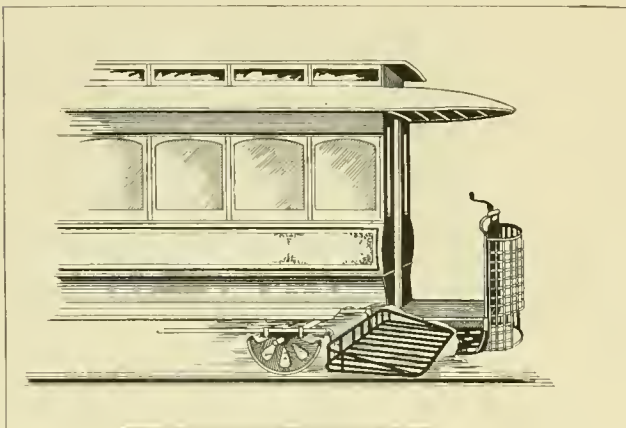

WHITE'S WRINKLE.

hung from the car body. This prevents up and down movement of the fender to a great extent, and it can consequently be carried nearer the pavement without striking obstructions,

The Thomson fender has been tried at Montreal on the St. Catherine Street line. Its construction and operation can be seen from the engraving.

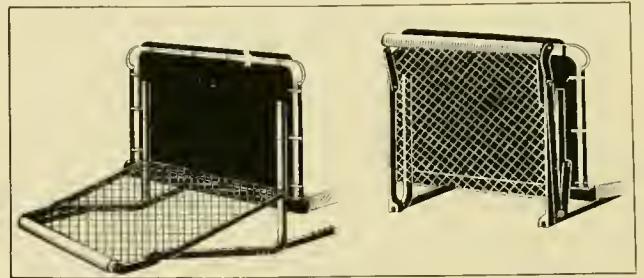

THOMSON'S PLAN.

The Lynn & Boston and Leonhardt fenders are also shown and can be easily understood.

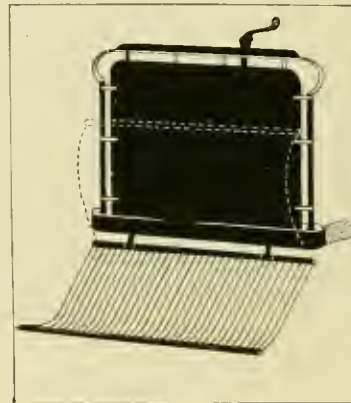

LYNN & BOSTON.

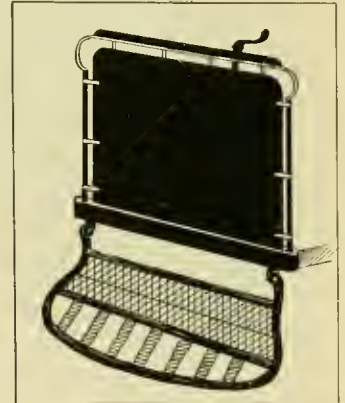

LEONHARDT FENDER.

T. C. Rice, of Worcester, Mass., owns a patent on the fender here bearing his name. It is intended to be carried one or two inches from the rail.

One of the most noteworthy of the proposed devices is Padrovonski's North American electro-pneumatic life saving apparatus. An air pump under the car creates a vacuum in an auxiliary reservoir. When a person gets in the "field of influence" in front of the car, the auxiliary reservoir is automatically opened and the air rushing into the funnel on the front dashboard draws the individual safely in.

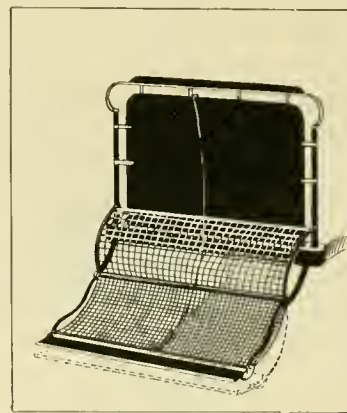

RICE PATENT.

One advantage of this plan is that it is necessary that people wear electric belts in order to be saved by it. Thus a road could collect a large royalty from electric belt makers as a return for adopting this life-saver. As the electric belt makers' profit is large, it is reasonable to think that this could be made a source of a good-sized revenue.

There remains two fenders, which eclipse all those previously described. One is the design of John Jackson, 1518 Byrd street, Baltimore. The franchise for the other is owned exclusively by the STREET RAILWAY REVIEW. They are both unparalleled in the history of the globe, and while it is usually hard to have to divide

the car and automatically rings a bell, warning the conductor that there are new arrivals from whom fare must

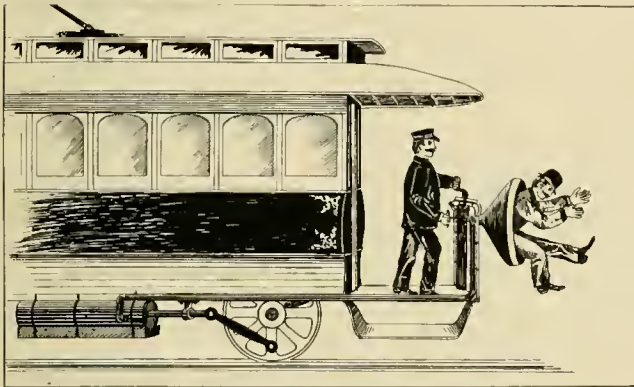

ELECTRO-PNEUMATIC LIFE-SAVER.

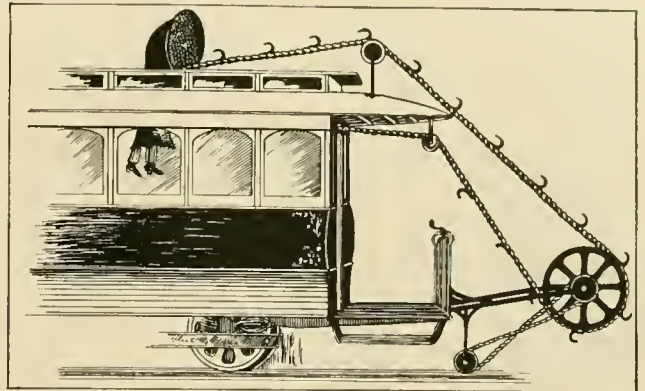

ALL OUR OWN.

be collected. Royalty rates for the use of this fender will be furnished on application.

## TOLEDO'S TRACKS.

the glory with another, we gladly do it in this case. The scheme of the gentleman from the city of fenders is to have an advance guard preceding the car at a respectful distance, which stops on coming in contact with a pedestrian. The said pedestrian is thus made aware that a car

The report on street railway tracks shows Toledo, O., to be lavishly supplied with the steel bands. The Consolidated Company proper has 86.20 miles of tracks. The Metropolitan branch has 15.48 miles, and the Cen-

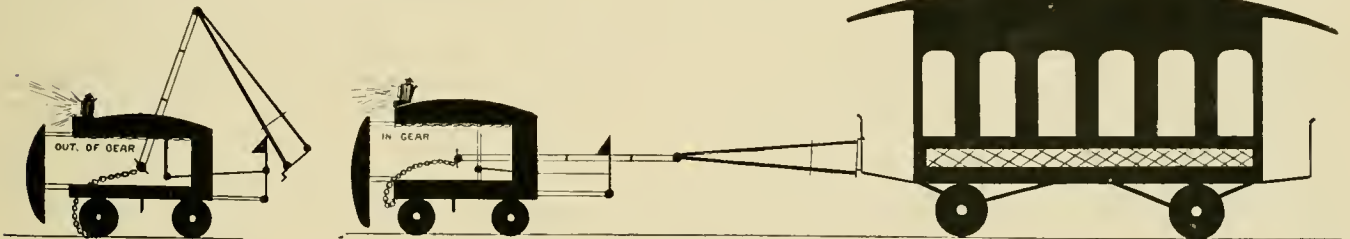

THE JACKSON SYSTEM, BALTIMORE.

is approaching and is expected to adopt measures to get out of the road. If he does not the mechanism between the advance guard and car begins to fold up in the manner shown and chains are automatically dropped in front of the guard's wheels. The motorman thus becomes aware that some one is on the track ahead and stops the car.

All of the devices heretofore provided are manifestly incomplete. The REVIEW fender performs all the functions which a fender should. Last month we published an extract from a Bridgeport paper, describing the way in which some of the present fenders might scoop up a whole nestful of people. These would be carried to the end of the line without paying fare. The REVIEW fender obviates this, while at the same time giving the fender victims a more comfortable place to ride. A series of rope drums are geared to the axle of a pair of driving wheels, run on the track in front of the car. Over these drums run a number of ropes provided with teeth. When persons are struck, they are carried up this "grain conveyor," and shot into a chute, which delivers them in

tral Passenger line 11.63 miles. This gives the Consolidated Company a total of 113.31 miles of tracks in Toledo. The Robinson system has 20.05 miles.

## OAKLAND'S PRIZES.

The Oakland Consolidated Street Railway offered a number of prizes for the most riding, giving to each passenger a check. The one turning in the most checks at the end of two months received the first prize; the next largest, second prize, and so down to \$4. By pooling the tickets the Associated Charities came first with 92,391 tickets and the \$60 prize; the second, third and fourth prizes also went to charity. It was considered a success by the company and the populace.

MANAGER BLACK, of the Niagara Falls Street Railway, was refused right of way through South Niagara Falls. The consequence is that the railway will not touch the village territory in going to Falls View, and the majority of the villagers execrate the council.

## BRAKES ON ELECTRIC ROADS.

Strange to say the street railways of some of our crowded eastern cities do not seem to be answering the demand of some people who ought to know better, for brakes that will stop a car within half its length from a speed of ten or fifteen miles an hour. We would suggest to those companies that a stick of cordwood or two carried on the front platform, and thrown in front of the car, would probably comply with this demand in about as neat a manner as anything. It would certainly be a cheap and simple method. True, it might half kill several people in the car, besides smashing the car and motors, but this would be no object if only a quick stop could be made.

In discussing this question from a common-sense standpoint it might as well be considered first as last that there is a practical limit under which a car at a given speed can not be stopped without injury to car or passengers. There are a great many accidents that are unavoidable by the motorman, occurring, as they do, in a less space of time than it takes to throw off the controller, to say nothing of putting on the brakes. With such accidents, of course the shortcomings of the brakes have nothing to do.

The question is not entirely one of emergency stops. It is one of both service and emergency stops. As air brakes made possible a fast suburban service on steam roads, so improved brakes on street railways ought to quicken the service as well as decrease accidents. There are plenty of small roads where the present ratchet brakes with long levers are good enough for present uses. At the same time there is no doubt but that the present crank and chain brakes can be improved on. The trouble with the common brake is not wholly with the force of application, but with the quickness. It is possible to skid the wheels with the majority of brakes now in use and this fact indicates that the force of application is even greater than necessary; but it takes several seconds to wind up the ordinary brake, so that the very time the application ought to be the heaviest, it is the lightest. Experiments on braking power show that the retarding effect of brakes is less the higher the speed, and that the friction between wheels and rails does not decrease in the same proportion. This means that the hardest application possible without skidding the wheels is at the highest speed. Some years ago, Mr. Westinghouse devised and tried an automatic apparatus for use in connection with the air brake, whereby the pressure on the brake shoes was made as hard as the wheels would stand without skidding, at high speeds, and then automatically decreased as the speed fell off. In this way the full braking power possible was realized. The automatic device was too complicated for every day use but it helped to illustrate the principle that the hardest application is needed at first. In addition to this, in street car work, it must be considered that, the liability of accident to persons is principally at the higher speeds. It is not so much a question of the total distance in which a car

can be stopped when there is a person on the track ahead, as it is how quickly speed can be reduced enough to allow that persons to get out of the way. These problems may appear to be the same, but they are not. If a car is going ten miles an hour the main question is, how soon the speed can be reduced to five miles an hour. It is easy to reduce it from five miles an hour to zero, and the probabilities are that this latter would not be necessary in the majority of emergency cases.

There is then a double reason why the brakes, of whatever kind, should be applied with their maximum force at first. This should hold not only in emergency but in service stops, for a much quicker service stop could be made if this principle were carried out. Air brakes are about the only ones that fulfill these two requirements at present, and those who can afford to put them on do so with the assurance that they will have something reliable.

There remains one other method that has been given enough of a practical every-day trial to make it worthy of consideration. We refer to the use of motors as dynamos. This method has been talked of ever since the beginning of electric railways but seems never to have been put into actual service with the one exception which is noted here. I. B. Walker, superintendent of the Sioux City Street Railway Company, has fitted out the cars which run over heavy grades on his line with this device, and the experiment has proved quite satisfactory, as was mentioned in a short description of this electric brake in the REVIEW, over a year ago. The cars, as wired by Mr. Walker, have a small switch in a box beside the controlling stand. When this switch is thrown, the trolley connection to the motors is cut off and the motors are connected with the controller in such a way that the rheostat is thrown into the motor circuit,—the amount of resistance in circuit being regulated by the controller as when the motors are drawing current from the trolley. Thus, when the controller is on the first point, the motors are sending current through the entire resistance, and with the controller on the highest or last point the motors are short circuited. The braking effect is greater the higher the speed and the less the resistance in circuit. When the speed is very slow the braking effect is so small as to be almost zero. For this latter reason it is not practicable to depend on the electric brake to make the entire stop. The use to which they are put at Sioux City, and the one to which they are best adapted, is to keep the speed down on grades. At that place a certain car goes down a 12 per cent grade two blocks long every twenty minutes, eighteen hours a day, the hand-brake never being used except to bring the car to a standstill. This grade formerly gave much trouble, and flat wheels were taken off a car every few weeks and sometimes every few days. Besides this, two accidents occurred owing to the wheels becoming locked. The wheels slipping, the car ran away down the hill. The braking power with slipping wheels is only one-third what it is just before the slipping begins. After the two accidents Mr. Walker put on the electric brakes.

With these, it is, of course, impossible to slip the wheels, as the instant a slip occurs, the motors which are acting as dynamos, stop and cease to generate. When the wheels again turn the motors resume their braking function. It is this automatic action which constitutes one of the chief beauties of this method of braking. At the same time it is absolutely reliable. The only objection that could be found is that it works the motors and rheostats at a time when they would otherwise be "resting." It would seem that this method might with advantage be given a trial in helping make regular service and emergency stops. As was pointed out, what is needed is heavy braking power at first, and this is just what the dynamo brake affords. Hand-brakes would of course be necessary to complete the stop after the electric brakes reduced the speed, but there is no doubt that the time of stop would be much reduced. The motorman could throw on the electric brake and have it in powerful operation at least two seconds before he could wind up a hand brake to where it would begin to do some good. The electric brake once on, the motorman would have time to put on the hand-brakes, which latter would be very efficient to complete the stop after the speed was reduced. Whether the motors would suffer unduly can only be told by actual experience. Various combinations of electric brake, switch and controller, suggest themselves, and it remains for the electrical manufacturing companies to put something of this kind on the market. The system is at least worth a trial and it need not be an expensive one, as it could be put on only one or two cars at first, and it could then be determined whether a more extended use of such brakes is desirable.

WALTON'S LINK BELTING.

The marvelous amount of "stretch" to be found in some link belts may fairly be compared to the contractive tendency of the proverbial woolen shirt when washed. A new link belt, in which such difficulties are said to have

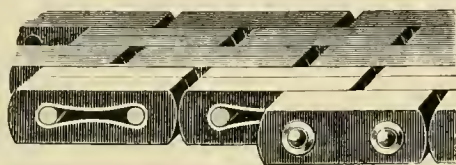

been eliminated, is the "Imperial Driver" of Walton & Sons, City Leather Works, Glasgow. In each link is an eye of weldless steel tube, forming the bearing surface of the pins. These also prevent wear, and their shape gives a slight spring action so that some of the characteristics of the link belt are preserved.

The Chicago City Railway Company distributed \$1,410, among its employes, as prizes offered last January for the best service during the Exposition period. The results, Mr. Bowen thinks, were satisfactory, and 20 men participated.

FRANK S. DE RONDE.

The general sales agent of the Standard Patent Company, Frank S. De Ronde, was born at Englewood, New Jersey, in 1870, and is consequently twenty-four years of age. Youth, in his case, he can "neither palliate or deny." After finishing school at Englewood, he took a business course in New York City. At the age of fifteen he went into the employ of a chemical house to learn the business. A year later he left this place to become office boy in the Standard Paint Company's office. His rise in this position was remarkable, going on the road in less than two years as salesman. His success as a salesman was no less remarkable, and at the age of twenty, in 1890, Mr. De Ronde was made general sales agent, with full charge of the traveling men and oversight of dozens of selling agents in branch houses.



F. S. DE RONDE.

In spite of his many business cares, Mr. De Ronde finds time for social duties and is a great lover of sports, keeping a number of fine horses. In addition to this, Mr. De Ronde takes an active interest in politics, following his brother, who was assemblyman before he was thirty and is now a state senator.

THE SCHOEN BRAKE SHOE.

The Schoen Brake Shoe Company of Pittsburg are putting on the market brake shoes of mild steel, one of which will, according to their tests, outlast eight cast iron shoes. This is accounted for in two ways. The actual wear on cast iron is greater than on mild steel, and the steel shoes can be worn thinner without breaking than can the cast iron. The steel used is very low carbon. That is, it approaches near to malleable iron. This

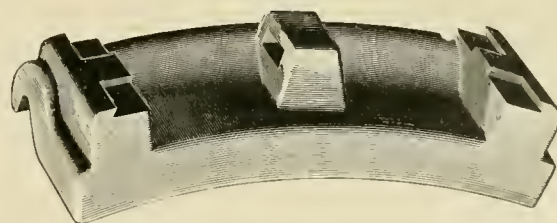

grade of metal is said to be the cheapest in the first cost. The shoes are forged by hydraulic pressure into any of the forms now in use. Shoes are absolutely uniform in quality and dimensions. As the wear of the steel shoe is so much slower, the labor of inspecting, cleaning and adjusting is much less. It goes without saying, that the amount of brake shoe metal necessary for a given service is not nearly what it is with cast iron. Roads which have used this shoe are pronounced in their expressions of satisfaction, and a trial is in nearly every instance, followed by a second order.

**THE KENSINGTON & STREATHAM CABLE RAILWAY.**

After many changes and vicissitudes the cable railway in London, England, between Kensington and Streatham, is now pronounced by the conservative Englishmen a financial and mechanical success. The plant was designed by Mr. Colam, C. E., of Edinburgh, and is very complete. The power house, an interior view of which we show, is a fine brick structure of sufficient size to admit of more power as it becomes necessary.

The engines used are a pair of compound non-condensing with cylinders of 20½ inches and 32 inches. Dr.

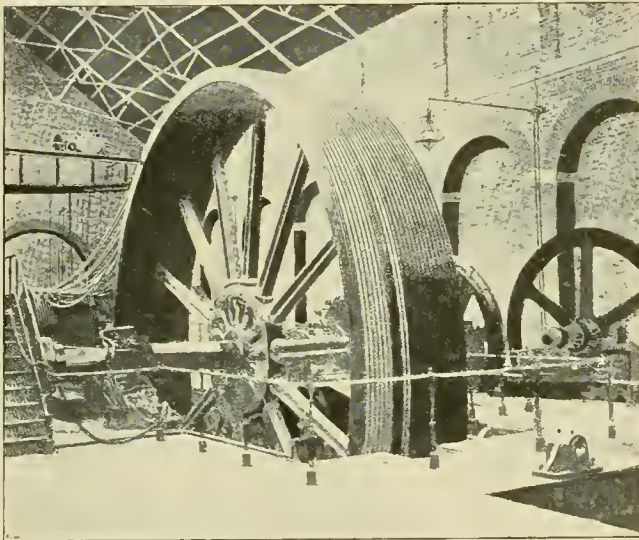

"The Driven Drum is 30 feet in diameter."

Proell's automatic, variable expansion valve gear is used on the high pressure cylinder while the low pressure is fitted with Corliss valve gear of the modern type. The fly-wheel is 16 feet in diameter. A rope drive is used, the driving pulley of which is 10 feet in diameter, grooved for 24 ropes of two inches diameter. The driven drum is 30 feet in diameter built up in segments with 14 arms. The shaft is 18 inches of forged Siemens' steel carrying friction clutches of special construction. The winding machinery is of the usual design and operates smoothly and efficiently.

**MAKING THE POLICE USEFUL.**

When in a Western city recently, the manager of the electric line spoke of the very great annoyance caused him in the past by boys stealing rides on cars. "But," said he, "it's different now. At my request the chief of police occasionally arrests and locks up for a few hours a boy when seen trespassing on our cars. I make it my business, when a new chief of police comes into power, to explain to him that it is a part of his duty to have his men watch the boys who make it a practice to hitch on the cars, and to make an example of some of them, occasionally, by arresting and locking up for a few hours. This generally lasts for several weeks. As this is all

we get out of the police for their rides, we do not feel we are asking anything out of the way. Besides, I consider it their duty to keep the boys off, if only as a safety measure to the boys themselves."

**MILEAGE AT AUGUSTA, ME.**

The trolley wheels of the Augusta, Hallowell & Gardner Railroad rubbed against 579,819 miles of wire in 1893. Some of the conductors rode 40,000 miles during the year, or an average of 109 miles every day, supposing that they worked every day. But one person was killed. Over two million were carried.

**THE SEVEY FARE BOX.**

While northern roads have settled down to the fare register as being the best available check on the honesty of the conductor, New Orleans roads have been experi-

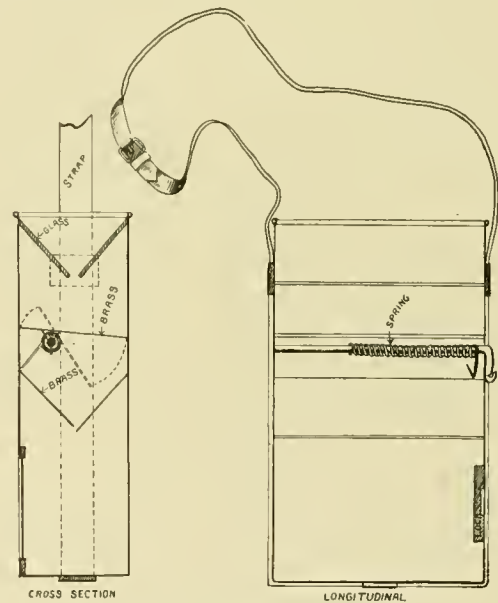

THE SEVEY FARE BOX.

menting with the attempt to make some improvements. One of the devices proposed, is the invention of W. S. Sevey. It is a fare box, to be carried by the conductor.

The passenger is expected to deposit the fare in the box. It falls into an upper chamber, as shown in the cross section. It is then in full view. The conductor turns the brass bottom of the upper chamber into the position shown by the dotted lines, and the money is emptied into the lower, where it can only be get at by unlocking a Yale lock. The intention is to have the boxes made of aluminum.

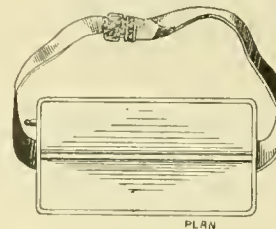

PLAN

The intention is to have the boxes made of aluminum.

FIVE motormen of Racine Street Railway Company have been discharged for hugging girls on the cars and visiting saloons while on duty.

## MAINTENANCE OF ROLLING STOCK.

Am I spending too much on the maintenance of my rolling stock and motors? Am I employing too many men around the barn and in the repair shop, or are there not enough to do the work properly? These are questions that appeal to the manager of every electric railway. Along with these questions come others, as to how often motors and trucks should be overhauled, and how many repairs are usually needed with a given mileage. In two previous articles in the October and November REVIEWS, entitled the "Electrical Inspection Department," the methods used on two roads were described in brief. In the present article the practices of a number of representative roads will be described more in detail.

DECATUR, ILL.

The City Electric Company owns in all eighteen motor cars. Of these eleven are equipped with single Thomson-Houston F-30 double reduction motors. Eight have Westinghouse single reduction motors of 25-horse-power, three being furnished with double and

### MOTORMAN'S REPORT.

#### Condition of Car No. \_\_\_\_\_

Motor .....	Brakes .....
Fields .....	Brake Shoes .....
Armature .....	Glass .....
Controlling Stand .....	Car Wheels .....
Cables .....	Car Body .....
Switches .....	Register .....
Lamps .....	Bells .....
Trolley Base .....	.....
Trolley Wheels .....	.....
Gearing .....	.....
Pinions .....	.....
Carbon Brushes .....	.....
Brush Holders .....	.....

If any of the above parts need attention make a X opposite the part to be repaired.

.....  
Motorman.

Date, \_\_\_\_\_ 189

Repaired by .....

Date, \_\_\_\_\_ 189

five with single equipments. While only a little over half the motors are required in the regular operation of the road during dull times, the existence of several pleasure resorts on the lines, and the fact that on special occasions enormous crowds are handled, makes necessary the large reserve. Two men are kept on the repair force. These men do their work entirely in the day-

time. The night inspection force consists of an engineer and fireman who go on duty at midnight and work on the cars until starting time in the morning when they start the power station machinery and run it until noon. There is also a man on duty in the car barn from 7 p. m. until 6 a. m. He acts as a watchman the first part of the night and receives the cars as they are brought in by the motormen. To him falls the duty of sweeping and cleaning. Another man working from noon till midnight does all-around-work on the line, in the barns, and anywhere else he may be needed. The engineer and fireman becoming inspector and helper, when at the barns, look over the cars each night. This inspection and oiling is thorough enough to make sure that everything about the motor is all right and no periodical overhauling is practiced. If anything is found wrong it is fixed immediately or the car is left in for the repair men to fix the next day. Trolley poles are made in the barn, of ordinary gas pipe. The eight Westinghouse equipments, consisting of eleven motors were bought in May, 1892. The record of electrical troubles on these motors is summed up in the grounding of one field coil and one armature. The gears of the three double equipments have not been renewed. Those of the single have. Some commutators on the road have lasted four years, and it is no uncommon thing to have one last a year without needing to be turned down. Brushes are soaked in oil. The presiding genius of the car barn and repair shop is G. J. Nitsche, who appreciates the fact that prompt attention to small troubles is the way to make a good record for motor maintenance, and governs himself and his men accordingly. The accompanying card has been used to act as a check on motormen. It is self-explanatory, the motorman being required to turn one in with his car every night.

BLOOMINGTON, ILL.

The Bloomington City Railway has two motor cars equipped with two Short single reduction motors, two cars singly equipped with Westinghouse single reduction motors and seven cars with double Westinghouse motors, making in all eleven cars. Nine are in regular use making a reserve of two cars. No inspecting or repairing is done at night, the reserve making it easily possible to do all necessary work during the day, when the light is good and conditions favorable to do thorough work. Two men are employed to do the repair work, both in the barn and on the overhead lines. An all-around-man cleans the commutators on the cars twice a day as they are waiting at the point of transfer in the center of the city. The night watchman at the barns and power house sweeps and cleans cars. It is arranged so that each motor is thoroughly overhauled every week by the electrician and his assistant. The nine Westinghouse cars went into use September 10, 1892. General Manager Patterson says that not a cent has so far been spent in repairs on them, with the exception of the renewals of controller tips. It is the custom during the summer to change the proportion of double and single motor cars by taking motors from the double equip-

ments, as the summer travel requires more cars and the conditions are not so trying as in winter.

#### SOME MASSACHUSETTS PRACTICE.

A considerable part of the time at the January meeting of the Massachusetts Street Railway Association was taken up by this subject, with special regard to maintenance in winter. Robert C. Brown, who represented the West End Company, of Boston, said that the inspection in their shops followed a routine which was much the same winter and summer. The entire equipment was W. P.-50 motors, all the old F.-30's having been thrown out. A hasty inspection of brushes, leads, etc., is made every day. Every third day each car is taken over the pit, and inspected from top to bottom. Every other third day the brush holders are taken out and cleaned, and the motor wiped. Once a month each motor is taken apart, the oil wells and everything about them being thoroughly cleaned and put in shape. The motors are then given a thin coat of asphaltum paint, which preserves the iron and makes it easier to keep clean. This monthly overhauling takes two men 2½ hours. The foreman gives this work his personal attention. There is scarcely any trouble from water on the motors. The openings on each side are fitted snugly with canvas, and a piece of canvas is also hung from the car body at the commutator end. E. C. Foster, of the Lynn & Boston Street Railway, said that his road had fifty F.-30 equipments, and seventeen Sprague No. 6. It also has a few W. P.-30, W. P.-50, and G. E. 800. The F.-30 give a great deal of trouble. The cost for labor and repairs to keep them in running order is about three times that of the W. P. The W. P.-30 are not heavy enough to do the work required on this road; hauling 10-seat cars with trailers over 5 per cent grades. It is merely a lack of capacity, however, as the W. P.-50 are very satisfactory. The G. E. 800 is a step in the right direction, being 1,000 pounds lighter than the old type, besides being more speedy and of greater capacity. They are greatly pleased with the type K controller. P. F. Sullivan, of the Lowell & Suburban, spoke of their early trials, caused by a lack of inspection. They use nearly the same system as the West End. They adopt a standard of car mile expense, and if the figure falls below it the foremen are given reason to expect a present at the end of the year. There are also prizes for motormen who make the best records with their cars, as regards expense and delays. While being trained, motormen are employed as helpers around the barn. Loss of mileage by any cause is traced directly to its cause. The Lowell, Lawrence & Haverhill Street Railway, represented by N. E. Morton, employs three night men in the car barn. Two of these do inspection work. If anything is wrong that cannot be fixed that night, a sign is hung on, "leave this car in." The greatest trouble they have is from wet track.

#### CENTRAL RAILWAY, PEORIA.

The Central Railway, of which C. E. Flynn is electrical engineer, was the first electric road in the state

of Illinois and, consequently, one of the first in the country. As with all other pioneer roads, the repair bills have been high, but under Mr. Flynn's able guidance they are being gradually reduced. The rolling stock of motors is as follows; Nine double W. P., 50; five double W. P., 30; eleven single F-40 (double reduction); sixteen double F-30 (double reduction); seven double Edison No. 4, single reduction, making a total of 48 cars. The regular number on the road is 32. All inspection is done during the day, each of the double reduction motors being run into the barn at some time during the daylight hours and looked over by a man kept there for the purpose, and the crew given another car. The W. P. motors are inspected and cleaned only once a month. There is one inspector at each of the two barns. These inspectors are assisted by three wipers at one barn, and two at the other. The repair shop force, which once numbered fifteen men, has been reduced to seven, and is still on the decline. This only goes to show what intelligent supervision and a proper system will do toward reducing expenses. The repair shop force is divided as follows: One foreman, one armature winder, one armature winder's helper, two roustabouts, one all round man. Nearly all repair work is done in the company's shop, very little being bought outside. Armatures of the type F, double reduction motors, seldom burn out when rewound in the shop; those shop wound being supplied with extra insulation between coils. It has been found that steel gears will last nearly as many months as cast iron will days, and, although the steel costs nearly three times as much, they are by far the most economical. Motor brushes are soaked in oil, and commutators are easily kept in good condition. Mr. Flynn favors keeping track of repairs by opening a separate account for each motor part, thus having one headed "fields," another "armatures," another "gears," etc. In this way the changing of motors and armatures from one car to another does not interfere with the accounts.

#### FORT CLARK HORSE RAILWAY, PEORIA.

This is a neat little electric line owning thirteen double W. P. equipments, of which eleven are in regular service. These are all looked over every night, and one of the motor equipments is taken apart every night. The round is thus made in eleven or twelve days, so that each motor receives an overhauling in that time. The principal repairs have been on gears and gear cases.

#### CHAMPAIGN, ILL.

The Urbana & Champaign Electric Railway keeps three motor cars on the road and four in reserve. They are Westinghouse, single reduction. Each crew is kept permanently with a car, and, when on every fourth day a crew is given a day of rest, the car is run into the barn and overhauled. The idea is that a crew will take better care of a car if they run it regularly, and if a car breaks down with uncommon frequency, it is known on whom to lay the blame. Two men are kept around the barn, and the work is done principally during the day.



## THE MONTHLY MASSACHUSETTS MEET.

The regular monthly meeting of the Massachusetts street railway association was held February 1st, at Young's Hotel, Boston, at six o'clock P. M. A special reception room was made headquarters, and the members found the social intercourse as pleasant, as the discussion was profitable.

Those sitting down at the banquet were: President Cunningham, of Plymouth Street Railway Company; Secretary A. E. Butler, of Lawrence; C. S. Sargeant, of the West End; Waterman Stone, of the Union Street Railway Company, New Bedford; Hon. E. P. Shaw, of Newburyport; B. J. Weeks, of the Quincy & Boston; Assistant Manager P. Winsor; Roadmaster R. H. Hapgood, and R. C. Brown, electrician, of the West End; General Manager E. C. Foster, and Maurice Hoops, electrician, of the Lynn & Boston; A. A. Glasier, and Charles S. Clark, of the Lowell & Haverhill; Gilbert Hodges, of Hodges & Harrington, railway experts; Geo. C. Moore, Rochester Car Wheel Company; J. F. Duggan, of the Burnham & Duggan Appliance Company; Jas. F. Shaw, manufacturers' agent; Charles Clark, New England agent of the Pennsylvania Steel Company; W. S. Key, of Electricity, and Fred. S. Kenfield, business manager, of the STREET RAILWAY REVIEW.

After the walnuts and coffee, Charles Clark read an interesting paper on "Rails and Track Laying," followed by discussion, in which the following took prominent part: Mr. Hoopes, on bonding; Mr. Winsor, on rails; Mr. Brown and Mr. Hodges, spoke on rail bonding. The discussion was informal but instructive. The next meeting will be held March, 1st, when mutual insurance for street railways will be discussed.

### HIS FEELING.

He could sit for hours and speak  
Things sublime in classic Greek,  
And, of the modern languages,  
He had mastered half a score.

He was gentle in his manner,  
He could play the grand piano,  
Of all his many virtues  
I can't tell half them o'er.

But a fatal trouble thrust him  
Far from humans, who all cussed him  
Because he was a fresh-air crank,  
And would not shut the car door.

## CANAL BOATS BY TROLLEY IN FRANCE.

On the canal between the Seine and the Saone, there is reported an interesting application of electric power to the propulsion of canal boats. It occurred to M. Galliot, an engineer at Dijon, to utilize the water power of the fall of water at the lock sluices to drive turbines and dynamos for this purpose. This scheme is said now to be actually realized, and an efficiency of thirty per cent between the turbines and the canal boats is said to be attained. The turbines are placed on the falls with

their spindles vertical, and are each capable of developing from fifteen to twenty horse-power. The vertical shaft of the turbine is geared by bevel wheels into the horizontal shaft of a dynamo. The electric power is conveyed along the canal by means of a phosphor-bronze overhead wire, 8mm. in diameter. Each motor boat is provided with a motor, which is driven by power taken from this trolley line. In addition to working the canal boats, the electric power is partly utilized to light up the interior of a length of tunnel through which the canal passes. The propulsion of the towing boat is effected, not by means of propellers on the boat itself, but by a train of gear wheels connecting the motor to a chain which extends along the bottom of the canal, and by means of which the boat drags itself along. Just how successful it is we cannot vouch, but the English Electrical Review says that it is actually the case.

## TAXES IN PROVIDENCE.

The Journal of Providence, R. I., has the following note of the taxes paid by the Union Railway Company, to the city:

"Recently the town has received \$800 from the Union Railway Company for one quarter's mileage, the contract being that the company shall pay to the town such part of one and one-half per cent, of the gross receipts from the entire plant as the miles of track in the town bear to the company's total mileage of rails. The receipts of the last quarter show that the town will derive over \$3,000 per annum from this source, which is considerably more than was anticipated. The company also pays taxes to the amount of nearly \$1,000 to the town and fire districts, which makes a total of fully \$4,000 per annum. It would seem that the town could afford to be somewhat generous to this company; \$4,000 is 5 per cent interest on \$80,000, which is a good deal more than the town has been obliged to expend on account of the railway being located here."

## THE COLUMBUS METHOD.

The city council of Columbus, Ohio, has set its seal of approval on good behavior in the street cars of their city, by passing the following ordinance:

"Whoever being requested by any employe of any street railway company of this city, or by anyone operating said road, to desist from smoking on or in any street car, fails to immediately do so, or uses obscene, profane or indecent language, or engages in any quarrel on or in such street car, or without permission takes a dog on, or in such car, or fails on demand to pay the proper fare on such car by delivering the money or ticket or depositing the same in a fare box, as he may be required by such employe, shall, upon conviction thereof, be fined in any sum not to exceed ten dollars with cost of suit, and be imprisoned until such fine and cost is paid; provided, that on demand of such fare, the person may immediately leave the car instead of paying such fare.

In Hungary considerable progress is being made in electric railway business. The Budapest Tramway Company has decided to convert about ninety kilometers of its horse tramway into an electric line, and is demanding an extension of the concession granted by the municipal authorities for a period of twenty-five years. An electric railroad is proposed at Carlsbad, to run from the railway station to the Kaiser Park. Work has been taken in hand in connection with the construction of the Baden-Voslau electric tramway. An electric tramway between Brux and Johnsdorf is proposed.

## MUNICIPAL OPPRESSION AT BALTIMORE.

A prominent firm of bankers and brokers of Baltimore, Md., in one of its circular market letters says of the new rapid transit regime and enterprise in Baltimore: "One not acquainted with the facts might suppose by the way the city officials talk that the street railway companies of Baltimore pay nothing for the privilege of using the streets, when, in fact, they pay the enormous amount of 9 per cent upon their gross receipts as a franchise tax. Is there any other business in existence which could pay such a tax and live? Very few, we think. Of course, those who had invested their money in Baltimore had no philanthropic intentions. They expected to make money, but they did not expect to be treated as aliens and that the city government should seize upon every pretext for increasing their tax bills. The city officials are probably feeling uncomfortable under the development of \$1,200,000 floating debt and a probable increase in the tax rate. The street railways pay now at least \$300,000 to the city in taxes, and will in a few years pay \$500,000 per annum. But the city officials are not satisfied, but are trying to kill the goose which lays the golden egg. How easy it is to dispose of other people's money! The projectors and builders of the Baltimore Traction Company came to Baltimore and transformed the antiquated and almost unbearable horse car lines into a system of rapid transit. They did more than that. They roused Baltimore from a sleepy village existence into bustling activity. Their enterprise not only added largely to the income of the city, but by bringing outlying districts into quick communication with the business center of the city, very greatly increased the value of real estate. They spent millions of dollars at Baltimore and gave and are still giving employment to large numbers. The people appear to appreciate what the Traction Company has done and is doing, but the city officials only recognize the company as fair game for exorbitant and excessive taxation and the City Collector says: 'The stockholders are foreigners who came here to escape taxation and who should be made to pay.'"

THE Cleveland Street Railway Employees Beneficial Association done magnificent work the past year, paying out 1,000 in sick benefits, and having \$800 on hand.

## A NEW TRAMWAY MAGAZINE IN GERMANY.

The Zeitschrift für Kleinbahnen, has made its debut at Monbijouplatz 3, Berlin, N., Germany, under the management of the commissioner of public works. The first number contains 64 pages of clearly printed matter, illustrated as necessity requires. It is in magazine form, 6 by 9 inches, and is devoted to the industrial railway, street railway and tramway interests of the world. The first number contains, besides a fairly complete review of contemporaneous literature, and industrial news and comments, longer articles from German authorities. Dr. Kohlmann, of Frankfort, has a review of street railway practice in America, which is to be continued. The first part is devoted mainly to the World's Fair. Electric traction is treated of in two articles, and what is evidently a full text of the recent law governing street railway operations, is printed. New projects and concessions are given a prominent place.

We are glad to welcome our latest contemporary, and wish it long life and much prominence.

An elegant calendar is the contribution of the Graham Equipment Company, of Boston and Philadelphia, to the New Year's list of remembrances of the editor.

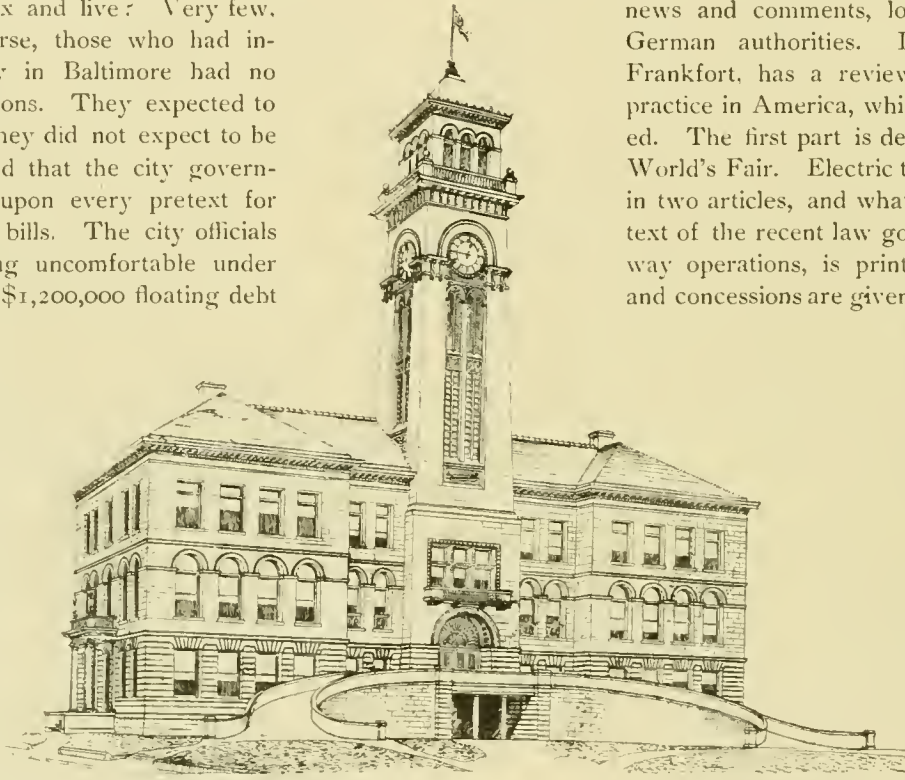

PERSPECTIVE.

BLACK AND GOLD is the combination of the cover of the folder sent out by the Baltimore Car Wheel Company containing two illustrations of the well-known Lord Baltimore truck. The specialty is neat and attractive.

## AN ELEVATED RAILWAY TERMINAL DEPOT.

At a recent competitive examination of the Chicago Architectural Sketch Club, the problem given was that of an elevated railway terminal station. Among the designs distinguished by honorable mention was one that commends itself on the score of simplicity and economy of space and the practicability of its method of handling the crowd. It is the design of Architect Henry K. Holsman of Chicago. The perspective shows a three-story building with a tower and entrance on a slope, thus accommodating with absolute safety large crowds without danger of injury by falling down steps. The section shown gives the general plan of the entrance of the passengers to the elevated structure of the railway, the incoming passengers

descending by means of the stairway shown and finding exit beneath the main entrance and at the sides of the building, thus in no case interfering with the out-going traffic. This advantage is readily seen and accomplished without

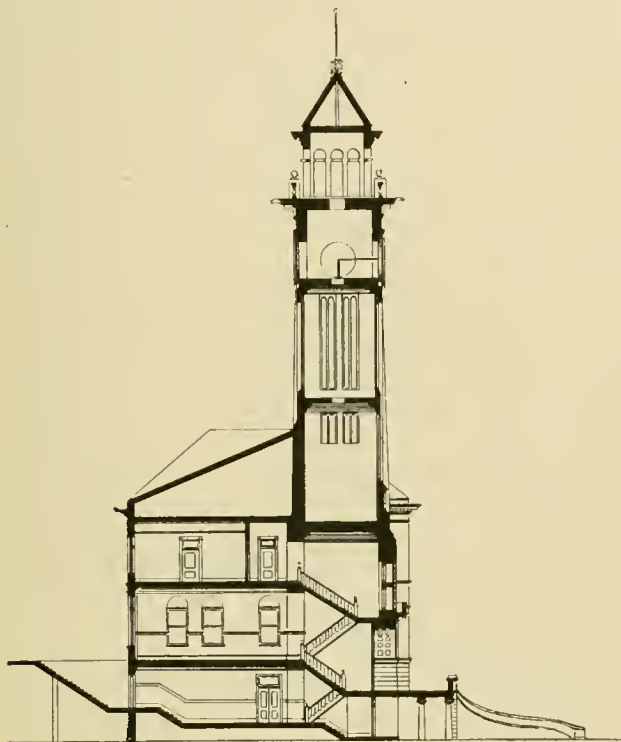

ELEVATION.

exposure of passengers in the meantime. The ground floor may contain offices and storage rooms ad libitum, as shown in Figure 4. The second floor, Figure 3, is self-

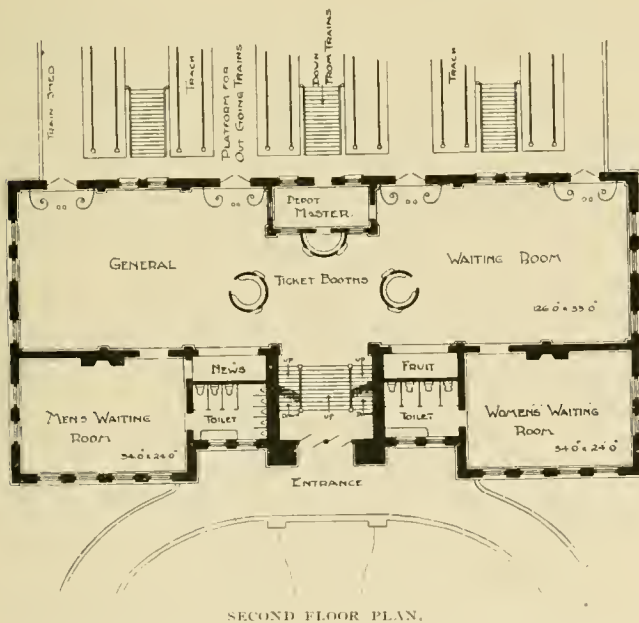

SECOND FLOOR PLAN.

explanatory and the third floor is supposed to be devoted exclusively to offices, executive or otherwise. Six tracks are designed for the station shown. The special feature of the design is of course the ease with which passengers

may be handled in very large number without mixing those in coming and those out-going.

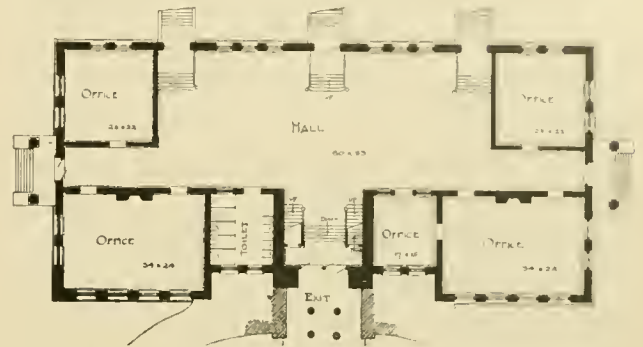

PLAN OF FIRST FLOOR.

THE NATIONAL RAILWAY COMPANY'S REPORT.

The National Railway Company, of Illinois, owning and operating five of the St. Louis street railways, comprehended under the Cass avenue and Fair grounds system, held its annual meeting, January 23. The principal owners are Chicago men.

The report reflects great credit on the management in general, and upon Capt. Robert McCulloch, in particular.

The net gains of the property were, \$199,947, or 9.0885 per cent on the stock, against 10 per cent earned in 1892. The receipts decreased 1.4 per cent. The operating expenses were 60.12 per cent of receipts, or, \$851,851. The net receipts were, \$564,966. The number of trips, last year, was 877,302, a decrease of 16,989; car mileage, 11,844,031; passengers carried, 28,313,504. Gross receipts of the cable lines, \$1,035,445; decrease, \$50,987; gross receipts of horse and electric, \$381,372; increase, \$30,258. The cable lines operating expenses were, 59.4 of the income; of the horse and electric, 64 per cent. The cost of operating cable, per mile, was 7.32 cents; including interest, 9.34 cents; cost operating horse and electric, 11.09 cents; including interest, 13.11 cents. The passengers carried, per car mile run, cable, 2.257; horse and electric, 3.082; total expenses, cable, 82.11 per cent; horse and electric, 85.05 per cent.

During the year, new construction cost, \$1,212,356, all paid. This includes 32.37 miles new track, 33.20 miles overhead equipment, together with new car equipment and remodeling of old cars, plant, etc.

The stockholders reelected the same management, with D. G. Hamilton as president, and E. Buckingham, vice-president.

THE rapid transit scheme of R. T. Wilson & Company for New York City is about to take aggressive form. Mr. Wilson's plan is for an underground railway electrically operated, lighted and heated, the city to loan \$30,000,000 for the plan, The company will supply \$15,000,000. Heretofore the constitution forbade the loan, but an amendment is to be submitted asking that the right to loan be given to the city.

## STREET RAILWAY LAW.

EDITED BY MR. FRANK HUMBOLDT CLARK, ATTORNEY AT LAW, CHICAGO.

*Reasonableness of City Ordinance Regulating Speed—  
Circumstances of Locality—Questions for Court and  
Jury.*

The reasonableness or unreasonableness of a city ordinance regulating the speed of engines or cars on the streets, is a question of law for the Court, and is not a question for the jury, unless it depends upon the existence of particular facts, which are disputed. Such an ordinance may be reasonable as applied to one locality, and unreasonable as applied to another. Although it may be reasonable as to populous parts of a city, it may not be so with reference to uninhabited districts near the corporate limits. If the nature of the locality is a matter of dispute, the Court should furnish the jury with the test by which the reasonableness of the ordinance, as applied to the particular locality, is to be determined; and it would be for the jury to say whether or not the ordinance was reasonable and applicable, according as they might think these conditions to exist or not. In the present case the Court charged that it was for the jury to decide upon the validity of the ordinance; yet no issue of fact had arisen which would require the submission to them of the question of its reasonableness in its application to the locality in which the injury took place. This we hold to be error.

(Supreme Court of Georgia, Metropolitan Street Railway Company vs. Johnson, 16 Southeastern Reporter 49.)

*Agent Employing Physician for Injured Person.*

Evidence that an agent of a street railway company was authorized by it to see that injured persons were taken where medical aid could be given, justifies the conclusion that the agent was authorized to employ medical aid in such cases.

In rendering the opinion the Court said: While a boy was getting off one of defendant's street cars, his arm was broken. He was taken by an agent or servant of defendant, one Shaw, to the plaintiff's office, he being a physician and surgeon. He performed the necessary surgical services, treating the boy until recovery. By this action he seeks to recover from the defendant for such services. The evidence tended to show that, when Shaw took the boy to the plaintiff's office, he requested the plaintiff to attend to the case, and assured him that the defendant would be responsible. The question is presented as to Shaw's authority to thus bind the defendant. He appears to have been an "inspector" whose general duties were to supervise the conduct of other employes in the car service, he acting as their superior. If no more than this had been shown, perhaps it could not have been inferred that he had authority from the defendant to employ a surgeon to treat an injured passenger; but it was shown that the defendant has instructed Shaw, in case of accidents, "to see that those injured were taken somewhere where medical aid could be given", and that he took this boy to the plaintiff pursuant to such instructions. This instruction may well be regarded as contemplating

the specified action on the part of Shaw, of his own volition and without any request by the persons injured, and so he appears to have acted in the case under consideration. Neither the boy, nor anyone in his behalf, appears to have made any request or to have exercised any choice or volition in the matter. It may be inferred from the evidence that Shaw, acting upon the defendant's general instruction as above stated, took the boy to this surgeon selected by himself, in order that the broken arm might be properly treated. From the evidence already referred to as to Shaw's authority in such cases, it might reasonably be considered, and so the Justice may be supposed to have viewed the case, that Shaw's instructions did not contemplate or mean merely that, he should remove injured persons to such a place that medical aid could be there bestowed, if a physician or surgeon should come there by chance, or in response to the request or call of any person; but rather that the meaning of his instructions was to place such persons under proper medical or surgical treatment—to see that they should receive such treatment. So construing the evidence, it went to show that Shaw's authority was such that, the defendant became chargeable upon his employment of the plaintiff in behalf of the defendant. Hence it is not necessary to consider the subject of ratification.

(Supreme Court of Minnesota. Hanscom vs. Minneapolis Street R. Co. 20 Lawyers' Reports Annotated 695.)

*Injury to Passenger—Negligence of Driver—Trench  
Underneath Track.*

The employes of defendant had made an excavation between the rails and outside of them, to a depth of six inches. The defendant's driver, against the warning of those at work upon the trench, drove on a trot into this trench, and the front wheels of the car, in which the plaintiff and other passengers were seated, dropped into the trench and injured the plaintiff by throwing him to the other side of the car, from the side upon which he was sitting at the time of the accident. There was no question but that the plaintiff was free from negligence. He was a passenger seated in the car reading and was injured without a moments notice of danger. The digging of a trench so deep as to weaken the track, so that it would not hold the car and the disregard of warning by the defendant's driver that he must stop his car, is such conclusive proof of the defendant's negligence that an assessment of damages was all that was left for the jury.

(Supreme Court of New York. Daub vs. Yonkers R. Co. 69 Hun. 138.)

*Collision with Wagon Crossing Track—Negligence of  
Street-car Driver.*

The plaintiff, at the time he was injured, was the driver of a beer wagon. His team were fairly heavy horses weighing about 1,300 pounds each. The wagon

and its contents weighed over two tons. The plaintiff drove across Third avenue, having previously looked up and down for cars and seen none. He crossed safely the south-bound track, and his horses crossed to the north-bound track and were upon the same when, upon looking southward, he saw a car coming up and distant about 60 or 80 feet. He signalled its driver, who apparently would not or did not see him, whipped up his horses, and had crossed north-bound track except the extreme rear part of his wagon, when his rear wheels were struck by the car. He was thrown out and severely injured.

The plaintiff was not bound to wait until the defendant's car passed him. If as a careful prudent driver he deemed it safe to cross the track in question, he had a right to do so. The car companies have not exclusive right to the public highways along which their tracks run; they are, through their drivers, required to exercise ordinary care and diligence in the management of their cars. The question whether or not plaintiff exercised his right to cross defendant's tracks, in a careful or careless manner, was a question for the jury to determine. They evidently believed that he was not careless, and the testimony is more than sufficient to justify that finding. Concerning defendant's negligence, that is also clearly established, for the testimony shows that the plaintiff's horses were actually upon the north track, when defendant's car was quite a long distance away. He, under the circumstances, had a right to go ahead, and it became defendant's duty to stop its car until plaintiff had passed over its said tracks. Its failure to stop its car was negligence, unless it was impossible to do so. The question whether or not defendant was negligent, was also submitted to the jury, who determined it affirmatively, and that conclusion is also justifiable by the evidence herein. City Court of (New York City. *Witzel vs. Third Avenue R. Co.*, 23 New York Supplement 317).

*Street Railway Track on Bridge—County Rebuilding Bridge after Destruction by Flood—Demanding Compensation for use by Street Railway.*

The corporate limits of the City of Rome extended to the further bank of the river, and the authorities of Floyd County built a bridge across the river, connecting a street of the city with its continuation beyond the river, and placed the bridge under the control and management of the municipal authorities, who took charge of it and engaged to keep it in repair, but stipulated that in case of its destruction or from any other cause they should not be bound to rebuild it. Under the power contained in its charter, and with the consent of the corporate authorities, both of the County of Floyd and City of Rome, a street railroad company constructed its tracks across the bridge, and ran its cars backwards and forwards over it until the bridge was washed away by flood. The County replaced the old bridge by a new structure upon the same site. The company set about laying its tracks over this new bridge, but the county authorities objected, unless the company would agree to pay for the privilege of using the bridge, and upon refusal to do so, filed a bill to

enjoin the use of it until the county should be compensated therefor.

*Held*, that the injunction was properly refused. The bridge forms a continuation of the street of the City across the river and is a part of such street.

Where any part of a public street or highway is washed out or otherwise destroyed by any means, and the damage is repaired by a new structure upon the portion thus destroyed, or rendered unfit for use; this does not give the County the right to exact additional compensation from a railroad company, which previously to the injury, used the street or highway with the assent of the municipality, where the railroad company proposes to make the same use of the street or highway after it has been repaired.

(Supreme Court of Georgia. County of Floyd vs. Rome Street Railroad Company. 77 Ga. 614.)

*Construction of Street Railroad—Limitation of Time—What Amounts to Occupancy of Street,*

An ordinance of the City of Houston granted to plaintiff the right to construct and operate a railway upon certain named streets. In the ordinance it was prescribed "so much of said railroad as extends \* \* shall be completed within one year from date, and the balance of said road shall be completed within two years). And so much of said right of way as may not be occupied by said Company within said time, shall be considered as abandoned". *Held*, that under this clause, upon failure to occupy, etc., within the specified time, the railway company forfeited its rights beyond that so occupied and no further; *i. e.*, the forfeiture did not extend to the completed work.

The extent to which the streets were occupied by the railway company, was a fact for the jury. It was improper for the Court to charge the jury that such occupancy existed "if the ties were laid and rails placed and spiked thereon".

The City, by its repealing ordinance, involved the right of the railway company to continue its work of construction in so much doubt, as to justify a discontinuance of the work until the effect of the ordinance could be judicially determined; and the time intervening between the passage of that ordinance and the final determination in favor of the right of the railway to continue its work should not be estimated against it.

(Supreme Court of Texas. Mayor etc., of City of Houston vs. Houston Belt & Magnolia Park Railway Company. 84 Tex. 581.)

*Passenger Expulsion from Car—Tender of Fare—Reasonable Amount.*

A passenger upon a street railroad is not bound to tender the exact fare, but must tender a reasonable sum and the carrier must accept such tender and furnish change to a reasonable amount. A tender of a five dollar gold piece by a street car passenger, who has no smaller change, is a tender of a reasonable sum; and the passenger who makes such tender cannot be ejected for refusal to pay his fare. But it does not follow that the passenger may tender any sum, however large: if he should tender

a hundred dollar bill, for example, it would be clear that the carrier would not be bound to furnish change.

(Supreme Court of California. *Barrett vs. Market Street Railway Company.* 81 Cal. 296.)

*Wagon Turning Out of Track—Damage by Car Approaching from Rear.*

The plaintiff drove a beer wagon along the track of the defendant on Third Avenue until he reached 33rd street, when he swung his wagon to the East in order to get out of the track and then turned to the West. The wagon was nearly off the track, when an electric car struck the hind wheel and overturned it.

This case was properly submitted to the jury. It was the duty of plaintiff to turn off seasonably to avoid the car approaching from the rear, and while so doing the motorman was bound to exercise proper care to avoid a collision with the wagon. Whether the plaintiff was guilty of contributory negligence and whether the motorman was negligent, were questions of fact for the jury.

(City Court of Brooklyn. *Witte vs. Brooklyn City R. Co.* 23 N. Y. Sup. 1028.)

### A STRAND DETECTOR.

An automatic strand detector, the device of Mr. Nash, superintendent of cables on the West Chicago cable system, is here represented, as may be seen by the illustration. It consists simply of two forked arms through which the two incoming cables run. In event of a "strand"

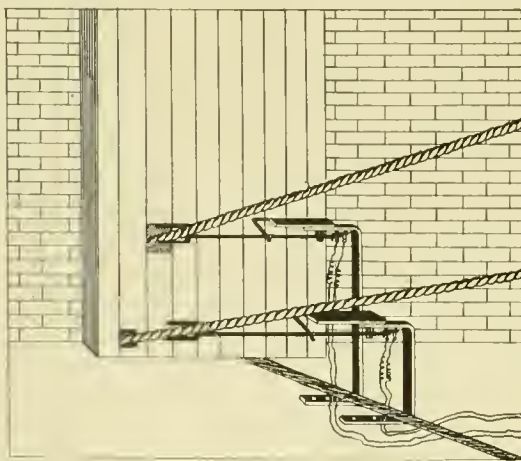

THE STRAND DETECTOR.

the loose wire pulls the arm which closes a circuit and rings an electric bell, properly denoting which rope is stranded. The detector is situated just inside the power house, so that the splicer may have time to get at the strand before the cable runs out again. The bell gives warning continuously until made ready for operation again. Lumps of tar on the rope will not set off the alarm.

NEW BRUNSWICK, and in fact all that portion of Canada, suffered from a tremendous snow storm January 12 and 13. All business, including street car service was stopped.

### KEEP THE TROLLEY ON THE WIRE.

A motor car stood "lifeless" in the middle of the street,  
And all its twenty passengers had risen to their feet,  
One said a "fuse" had burned away, with elongated face,  
Another that a "plug" was blown out of its proper place,  
And all agreed they'd be delayed at least one tedious hour  
Before they could go forward and regain the absent "power."  
At last a modest little maid, whom none could but admire,  
Exclaimed: "I'll tell you what it is—the trolley's off the wire."

In household matters, love affairs, in monetary things,  
If happiness escapes you upon quick-departing wings,  
Don't worry, flurry, fuss and fret, but keep your temper down,  
Nor let your placid brow be marred by wrinkle or a frown;  
When friends desert, and enemies with hate would pierce you  
through,  
And everything perplexes, and you don't know what to do,  
Don't be discouraged or dismayed, nor from the world retire,  
But ask yourself this question: Is the trolley on the wire?

In any situation, though you be in sorrow clad,  
Don't be of doleful countenance and to your troubles add,  
Maintain a constant equipoise and peaceful frame of mind,  
And cast anxiety and care to the passing wind,  
In the hurly-burly of the rough-and-tumble world,  
Though at him shafts of malice were unscrupulously hurled,  
I never knew a man to fail, with high ambition's fire,  
Who kept, with strong and steady hand, the trolley on the wire.  
—MAHLON M. DELEVIS, in Omaha Bee.

### ANN ARBOR'S FIRE.



CARS went up in smoke early Thursday morning, January 25, when the car barn and rolling stock of the Ann Arbor Street Railway Company was destroyed by fire. The loss entailed was \$21,200, with insurance to the amount of \$11,000. The cause of the fire is not known. The current had been entirely shut off and the night watchman was cleaning the last car. Spontaneous

combustion is thought of as a probable cause and some hint at incendiarism. The watchman ran one car out of the barn. Five motors and a trailer were destroyed. This casualty stops street railway traffic until new cars can be procured.

### VEHICLES FOLLOWING STREET CARS.

An ordinance has been passed in New Orleans intended to prevent accidents, especially to pedestrians crossing a street immediately in the rear of a car. The text reads as follows:

BE IT ORDAINED, That from and after the passage of this ordinance, it shall be unlawful for any vehicle to follow in the tracks of any street railroad, any cars of said railroads, electric or otherwise, at a distance less than thirty feet.

Be it further ordained, That any vehicle following any street car at a distance of thirty feet, shall be compelled to stop immediately at said distance whenever said street car ahead of said vehicle shall have stopped.

Be it further ordained, That any driver of any vehicle or vehicles who shall violate the foregoing provisions of this ordinance shall be guilty of a misdemeanor and subject to a fine of five dollars nor more than twenty-five dollars or imprisonment for five nor more than thirty days, at the discretion of the Recorder having jurisdiction of same.

## BOYNTON'S BICYCLE FOR BOSTON.

In order to give the 1,000,000 people within ten miles of the center of Boston rapid transit, E. Moody Boynton, of bicycle railway fame, wishes to supplant subway, electric and elevated railway schemes with his own particular brand of rapid transit.

To this end, James B. Bell, 178 Commonwealth avenue, Boston, Maj. Gen. O. O. Howard, New York, Robert D. Evans, president American Rubber Company, and others, have filed six important charters covering five routes and a circle railway, connecting all the Boston depots, Cambridge, Somerville, Lowell, Lynn, Salem, Beverly, Quincy, Brockton, Dedham, Attleboro and Providence. The terminal will be 800 feet long, and connect central points by means of covered ways, all at the second floors of buildings. The Boynton is a single rail affair, permitting of quadruple tracks in a small space. The structure will be elevated 16 feet, and the cars driven electrically. A description of this system was given about two years ago in the REVIEW.

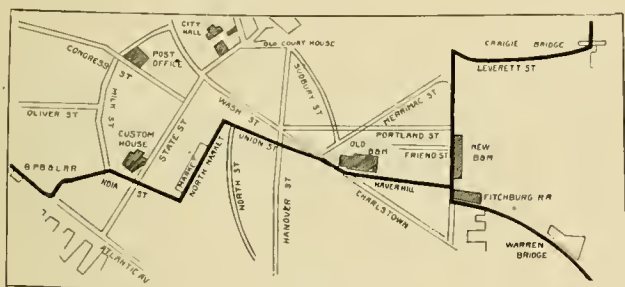

PROPOSED ROUTE OF BICYCLE RAILWAY

From Craigie Bridge the line continues through Charles street and Columbian avenue to Roxbury.

From Revere Beach and Lynn the line continues up Purchase street to South Boston.

A branch line connects Purchase street and Columbus avenue via Eliot street.

From Fitchburg depot the line continues to Charlestown.

## STREET CAR FLIRTING.

If the New York Recorder is to be believed street car flirting is a dangerous thing.

A judge, riding in the cars recently, from a single glance at the countenance of a lady by his side, imagined he knew her, and ventured to remark that the day was pleasant, says the Boston Courier. She only answered: "Yes!"

"Why do you wear a veil?"

"Lest I attract attention."

"It is the province of gentlemen to admire," replied the gallant man of law.

"Not when they are married!"

"But I am not."

"Indeed!"

"Oh, no! I'm a bachelor!"

The lady quietly removed her veil, disclosing to the astonished magistrate the face of his mother-in-law. The judge has been a raving maniac ever since.

## AT YOUNGSTOWN.

With the opening of the new year several important changes were made at Youngstown, Ohio, and include the election of two gentlemen well known to the street railway fraternity.

A. A. ANDERSON,

the new general manager of the Youngstown Electric Railway Company, is a man of thorough railroad experience.

Mr. Anderson was born September 1, 1859, in Edina, Missouri, but immediately after the war removed to Jacksonville, Ill., with the family, consisting of his widowed mother and three children. After a brief residence in Jacksonville the Andersons again removed, this time to Indianapolis, where they have since resided. In 1878 he began in the street railway business under Hon.



Tom L. Johnson and survived every change of administration until 1893. He was made secretary and treasurer in 1886 and assistant to the general manager for five years. His new position finds him eminently well fitted for the task.

S. F. HAZELRIGG,

the new superintendent of the Youngstown road, is also an Indianapolis man. He was born at Greenburg, Ind., in 1862. At the age of 17 he began railroading and settled at Indianapolis, where he has resided until this year.

His street railway experience is a varied one, beginning as a driver and serving successively and successfully as division superintendent, foreman of shops and purchasing agent. Mr. Hazelrigg's entire education seems to point out the line of work in which he is now placed.



## ST. LOUIS PASSENGERS.

The quarterly street railway report for St. Louis street railways shows: The total number of trips made were 1,379,020, and 22,963,702 passengers were carried.

The total number of trips made in 1892 was 5,361,973, carrying 91,685,555 passengers. In 1893 5,993,178 1/2 trips were made, carrying 95,680,550 passengers.

ALLEGHENY, Pa., wins its lawsuit against the Millvale line, the Supreme Court deciding for the local authorities under the statute. The fight was to resist taxation of dividends.

THEY SAW STARS.



FULTON STREET near the bridge entrance, in Brooklyn, there is a great network of tracks, trolley wires, and elevated railway structure. An electric rambling down that way not long ago suddenly stopped, and began to shoot out a mass of sparks and molten metal, in the most approved "deadly trolley" style. The trolley had jumped the wire, and had become jammed against the iron of the elevated railway, bringing the trolley pole at about the middle against the wire. This simple re-arrangement made the elevated structure a return, and the line was short circuited at that point, with the result of heating the iron pole. The brave conductor did his best to release the pole, but could break the circuit for only a few minutes at a time. The pole thus became white hot, with the pyrotechnic results above noted. The motorman poured water on the car roof, which had been ignited by the falling sparks, thus saving the car from burning. Then he improvised a trolley by sticking an iron switch hook on the wire, until the car could be backed on to a side track. The jury-trolley also spurted forth a beautiful, new line of fireworks, which the motorman fore-fended by turning up his coat collar as high as possible.

The scene was a brilliant one, and called for a first rate exhibition of nerve and common sense on the part of the employes. The man at the helm, however, said the experience was more unusual than pleasant, and reminded him strongly of a place he had never visited, but had read about.

THE BARROW BRAKE.

This brake is the invention of T. J. Barrow, of Duluth, Minn. It has four independent shoes, any one of which

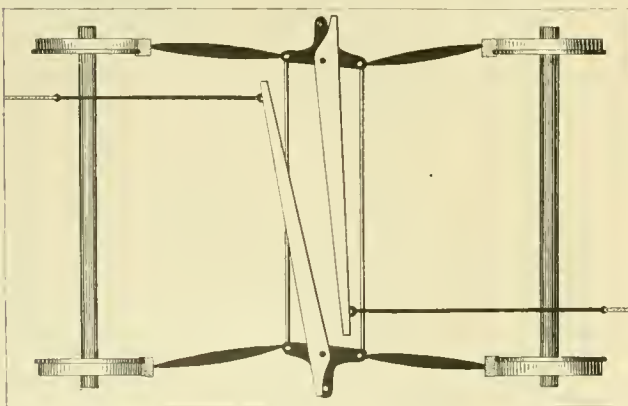

THE BARROW BRAKE.

can become worn or loose without interfering with the others. The drawing, which is a plan view with the brake on, explains its action. One point in its favor for use on modern motor cars is, that it takes very little room under the car, or rather takes none of the room

usually wanted for something else. It is needless to say that the leverage is great, and it is very powerful in its action. It is so simple that it can be turned out at any street railway blacksmith shop.

AN ENGLISH FREAK.

A patent has been recently taken out in England on an aerial railway. An electric motor suspended from an elevated cable derives its current from a neighboring con-

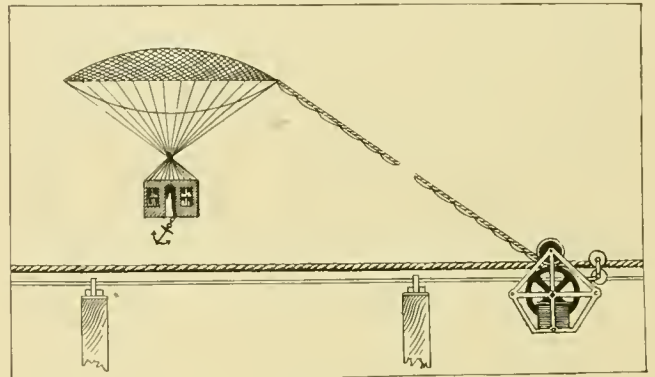

A SURE WINNER.

ductor, and hauls the elongated "arostat." The latter is hauled down at stations by the appendant anchor. We would recommend the combination for the \$50,000 Metropolitan Traction Company prize.

THE DUNCKER TROLLEY HEAD.

A very ingenious form of trolley head is the subject of a recent patent granted to W. F. Duncker, of Steelton, Pa. It does not necessitate any radical change from the

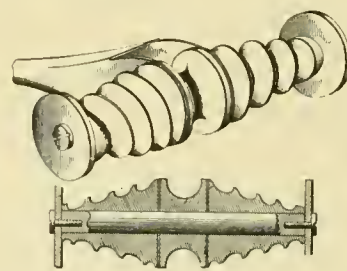

DUNCKER TROLLEY.

present construction of trolley wheels, and can easily be put on any pole. A spiral attachment is put on each side of the trolley fork. These are as free to turn as the trolley wheel. When the wheel leaves the wire these immediately return it.

The attachments are of metal, so that the current is never cut off. It is manifestly impossible for a trolley to leave the wire on a straight track with this in use. The principal objection to it is that it might catch on curve insulators, switches and pull-offs, on account of its length.

A DASTARDLY attempt to wreck an electric car was made by some unknown parties at Indianapolis lately. A stout wire was stretched across the track in the middle of a long block, just high enough to strike the motorman's stomach. A vestibuled car was the first to pass, saving some motorman's life, as the vestibule struck the wire first. The shock was severe enough to throw the car back.



## STREET RAILWAY LABOR IN OHIO AND MISSOURI.

The Ohio Bureau of Labor Statistics has issued its report for 1892, under the supervision of W. T. Lewis, commissioner. The work is very thorough. The facts and figures given from twenty-seven street railways in that state will be interesting for comparison. Reports are given from fourteen electric, eleven horse, one cable, and one electric and horse road. The capital invested per mile of electric road was \$25,827; cable, \$77,777; horse, \$16,644. The amount paid for wages was 41.9 per cent of the gross earnings. The amount paid for office help and management was 5 per cent and the insurance and taxes 3.7 per cent of the gross earnings.

The following tables have been selected because they give the reports of roads equipped entirely with electricity and may be compared with the numerous other similar roads throughout the country. Although the number of cars in daily operation is not given, the number of motormen will furnish enough information for an approximate guess.

### AKRON STREET RAILWAY.

	Number.	Hours per day.	Wages per day.
Conductors.....	35	12	\$1 50
Motormen.....	33	12	1 50
Trolley men.....	5	12	1 50
Linemen.....	2	12	1 50
Laborers.....	10	10	1 50
Motor repairers.....	6	10	1 75
Motor inspectors.....	4	12	2 00
Car cleaners.....	4	12	1 50
Engineers.....	2	12	2 25
Firemen.....	2	12	1 50
Blacksmith.....	1	10	1 50
Cashier.....	1	12	2 00

### ALLIANCE STREET RAILWAY.

	Number.	Hours per day.	Wages per day.
Motormen.....	5	12	\$1 50
Lineman.....	1	10	1 50
Laborers.....	2	10	1 50
Motor repairer.....	1	10	1 50
Car cleaner.....	1	10	1 50
Engineers.....	2	10	2 50
Firemen.....	2	10	1 65

### CANTON STREET RAILWAY.

	Number.	Hours per day.	Wages per day.
Conductors.....	20	12	\$1 50
Motormen.....	32	12	1 50
Linemen.....	2	10	{ 1 50 1 75
Motor repairers.....	3	10	{ 2 00 1 75
Motor inspectors.....	2	10	1 65
Shedman.....	1	12	1 60
Lamp tender.....	1	12	1 50
Engineers.....	2	12	2 25
Firemen.....	2	12	1 50

### DEFIANCE ELECTRIC LIGHT & POWER COMPANY.

	Number.	Hours per day.	Wages per day.
Motormen.....	4	11	\$1 50
Lineman.....	1	10	1 50
Laborers.....	5-50	10	1 25
Motor repairers.....	1	10	1 50

Lamp tender.....	1	10	1 50
Engineers.....	2	12	{ 2 50 1 25
Fireman.....	1	12	1 00
Superintendent.....	1	--	2 50
Foreman.....	1	--	2 00

### EAST LIVERPOOL & WELLSVILLE ELECTRIC STREET RAILWAY.

	Number.	Hours per day.	Wages per day.
Conductors.....	10	10	\$1 75
Motormen.....	10	10	1 75
Motor repairers.....	1	10	2 50
Motor inspectors.....	2	10	1 75
Car cleaner.....	1	10	1 50
Engineers.....	2	10	2 25
Firemen.....	2	10	1 75

### PIQUA STREET RAILWAY.

	Number.	Hours per day.	Wages per day.
Motormen.....	8	11	\$1 42
Shedman.....	1	10	1 30
Engineers.....	2	8	{ 1 75 1 25

### SPRINGFIELD ELECTRIC STREET RAILWAY.

	Number.	Hours per day.	Wages per day.
Conductors.....	6	16	\$1 75
Motormen.....	7	16	1 75
Lineman.....	1	10	2 00
Laborers.....	3	10	1 50
Motor repairer.....	1	10	1 50
Shedman.....	1	10	1 50
Car cleaner.....	1	10	1 50
Watchman.....	1	10	1 50
Superintendent.....	1	--	3 00

### YOUNGSTOWN STREET RAILWAY.

	Number.	Hours per day.	Wages per day.
Conductors.....	24	12	\$1 75
Motormen.....	12	12	1 75
Lineman.....	1	10	1 75
Road master.....	1	10	1 65
Motor repairers.....	7	10	1 75
Car cleaners.....	2	12	1 75
Lamp tender.....	1	10	1 75
Watchman.....	1	12	1 85
Engineers.....	2	12	2 75
Firemen.....	2	12	1 75
Cashier.....	1	8	2 50

### TUSCARAWAS ELECTRIC COMPANY.

	Number.	Hours per day.	Wages per day.
Motormen.....	3	12	\$1 60
Laborer.....	1	12	1 50
Engineer.....	1	10	2 50
Firemen.....	3	12	1 60

### CITIZENS' ELECTRIC STREET RAILWAY, MANSFIELD.

	Number.	Hours per day.	Wages per day.
Conductors.....	3	11 <sup>1</sup> / <sub>3</sub>	\$1 70
Motormen.....	10	11 <sup>1</sup> / <sub>3</sub>	1 70
Lineman.....	1	10	1 66
Laborer.....	1	10	1 35
Motor repairer.....	1	10	2 50
Motor inspector.....	1	12	1 66
Engineers.....	2	12	2 00
Firemen.....	2	12	1 66
Cashier.....	1	8	*25 00

\*Per month

# Street Railway Review

## BROOKLYN STREET RAILROAD, CLEVELAND.

	Number.	Hours per day.	Wages per day.
Conductors.....	65	10½	\$0 18
Motormen.....	68	10½	20
Trolley men.....	12	12	12½
Linemen.....	2	12	{ 2 50 { 2 25
Laborers.....	25	10	1 50
Motor repairers.....	26	12	{ 1 50 { 2 50
Motor inspectors.....	4	12	2 00
Shedmen.....	7	12	1 75
Car cleaners.....	9	12	{ 1 50 { 1 75
Engineers.....	4	12	{ 2 75 { 2 50
Firemen.....	4	12	1 75
Oilers.....	4	12	1 50
Wood workers.....	4	10	2 25
Blacksmiths.....	2	10	2 25
Cashier.....	2	12	3 25

\*Per hour.

## BROADWAY & NEWBURGH STREET RAILROAD, CLEVELAND.

	Number.	Hours per day.	Wages per day.
Conductors.....	55	9-10	\$0 18
Motormen.....	60	9-10	20
Linemen.....	2	9-10	{ 2 00 { 2 25
Laborers.....	4	10	{ 1 75 { 1 50
Motor repairers.....	20	10	{ 1 75 { 2 50
Car cleaners.....	3	10	1 75
Engineers.....	2	12	{ 3 00 { 2 50
Firemen.....	2	12	1 75
Oilers.....	1	12	1 75
Wood workers.....	2	10	{ 2 25 { 2 00
Blacksmiths.....	9	10	{ 1 75 { 2 50
Watchmen.....	3	—	1 75
Painters.....	4	10	{ 2 50 { 1 75
Starters.....	4	12	2 25

## EAST CLEVELAND RAILROAD.

	Number.	Hours per day.	Wages per day.
Conductors.....	150	10	{ 1 80 { 2 00
Motormen.....	150	10	{ 1 80 { 2 00
Trolley men.....	35	10	1 50
Linemen.....	5	10	2 05
Motor repairers.....	25	10	{ 1 50 { 3 00
Motor inspectors.....	8	10	2 00
Car cleaners.....	20	12	{ 1 50 { 2 25
Watchmen.....	5	12	{ 2 00 { 2 50
Engineers.....	3	10	{ 2 35 { 4 00
Firemen.....	6	10	{ 1 50 { 2 00
Oilers.....	2	10	1 50
Dynamo tenders.....	2	10	2 35
Wood workers.....	15	10	{ 2 00 { 2 35
Blacksmiths.....	6	10	{ 1 75 { 2 50
Painters.....	5	10	{ 2 00 { 3 00
Cashiers.....	4	8	{ 1 50 { 2 00

## GLENWOOD AND GREENLAWN STREET RAILWAY, COLUMBUS.

	Number	Hours per day.	Wages per day.
Conductors.....	8	12	\$1.74
Motormen.....	8	12	1 62
Shedmen.....	2	12	{ 96 { 2 00
Firemen.....	1	12	{ 50 00† { 70 00

†Per month.

## NEWARK & GRANVILLE ELECTRIC STREET RAILROAD.

	Number.	Hours per day.	Wages per day.
Conductors.....	9	13	\$1 50
Motormen.....	9	13	1 50
Lineman.....	1	—	2 00
Laborers.....	5	10	1 25
Shedman.....	1	—	1 25
Watchman.....	1	—	1 50
Engineers.....	2	12	2 00
Firemen.....	2	12	1 50
Groom.....	1	—	1 35
Painter.....	1	10	2 00
Cashier.....	1	—	2 50
Foreman.....	1	—	1 65

## ZANESVILLE STREET RAILWAY.

	Number.	Hours per day.	Wages per day.
Conductors.....	14	12	\$1 43
Motormen.....	16	12	1 43
Linemen.....	2	10	1 50
Laborers.....	6	12	1 50
Motor repairers.....	1	12	2 00
Car cleaners.....	1	10	1 50
Lamp tenders.....	1	10	1 50
Blacksmith.....	1	10	2 00
Cashier.....	1	—	2 00

## WHITE LINE STREET RAILROAD, DAYTON.

	Number.	Hours per day.	Wages per day.
Motormen.....	21	12	\$1 50
Motor repairers.....	2	10	{ 2 00 { 2 85
Car Cleaner.....	1	10	*50 00
Watchman.....	1	10	1 50
Engineers.....	2	10	{ 2 00 { 2 75
Firemen.....	2	10	{ 1 50 { 1 75
Wood worker.....	1	10	2 00
Blacksmith.....	1	10	2 00
Cashier.....	1	10	1 00

\*Per month.

## HAMILTON & LINDENWALD ELECTRIC TRANSIT COMPANY.

	Number.	Hours per day.	Wages per day.
Conductors.....	18	12	\$1 50
Motormen.....	18	12	1 50
Lineman.....	1	9	2 50
Laborer.....	1	10	1 25
Motor repairers.....	2	10	{ 2 00 { 2 50
Car barn boss.....	1	10	1 50
Car cleaners.....	5	10	1 25
Engineers.....	2	10	2 00
Fireman.....	1	10	1 50
Wood worker.....	1	10	2 00
Cashier.....	1	11	1 40

The state of Missouri is to be congratulated on having so fair minded a labor commissioner, in the person of Henry Blackmore. In the introduction to the section of the report covering street railways, some statements are

made which show the real status of street railway investments, as opposed to the newspaper idea. He says:

"The amount of capital invested is \$31,367,359 (in Missouri). The gross earnings for the last fiscal year (ending November 5, 1893), amounted to \$6,049,374. This is as returned by the corporations, with one exception, which is an estimate. The percentage of the gross earnings to the capital invested is 19 per cent. The net earnings, after deducting the amount paid out for wages, salaries and improvements, are \$2,707,247, or 8.63 per cent of the capital invested. The amount paid out for wages and salaries aggregates \$2,687,896, or 8.56 per cent of the capital invested. The amount paid for wages, salaries and improvements amounts to \$3,342,127, or 10.65 per cent of the capital invested. The ratio of the wages, salaries and improvements is 55.24 per cent of the gross earnings. The wages and salaries amount to 44.43 per cent of the gross earnings. The wages are 41.20 per cent of the gross earnings. The improvements amount to 10 per cent of the gross earnings. \* \* \* A study of these statistics reveals the fact that these corporations in the aggregate, many of them doing an immense business, do not make a large profit on the investment. Deducting \$3,342,127, the aggregate of wages, salaries and cost of improvements, from \$6,049,374 gross earnings, leaves \$2,707,247 as the net earnings, which is 8.62 per cent on the capital invested. If there is a bonded debt in addition to the capital, on which interest must be paid, the per cent on the investment would be still further reduced. \* \* \* This class of property, in the smaller cities, and some of the lines in the larger cities, have returned no dividends to the investors, though the newspapers frequently advertise to the public that certain lines have wonderfully valuable franchises."

He also gives the companies due credit for the enterprise they have shown in keeping pace with improvements, and considers the condition of street railway employes good. A number of interviews with conductors and motormen are published, which show the men to be well satisfied, the main objection to the work being the suffering during cold weather.

THE Halle (Germany) Tramway, although its extension has only been nine months at work, pays  $7\frac{1}{4}$  per cent dividend. The Breslau Tramway has been working since June; the Essen Tramway has been running since the end of August; the Kieff Tramways are all to be changed into electrically-driven roads. Electric traction is being started also at Chemnitz, Dortmund, Lubeck and Christiania. All the above undertakings have been, or are being, carried out by the Allgemeine Elektricitats-Gesellschaft. The Leipzig Town Council have published a specification for an electric tramway in certain parts of the town, on the basis of a forty-year concession.

THE Dublin United Tramways Company has issued its annual report. The net earnings for 1893 were three per cent of the capital stock of \$2,751,000.

TIE RODS AND TIE PLATES.

A circular recently issued by William Wharton, Jr. & Co., shows plainly why tie rods are not articles to which much faith can be pinned, and why they have in times past betrayed the faith imposed in them. Figure 1

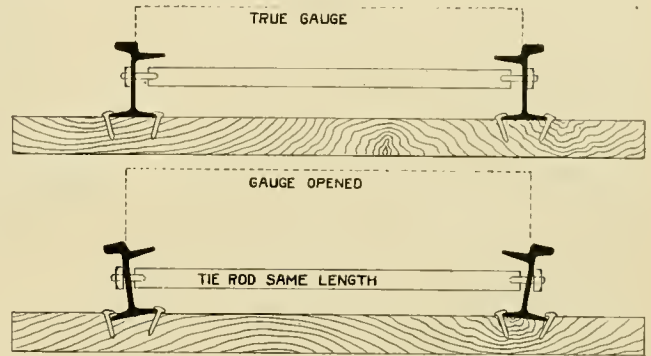

shows the track and tie rod new, and Figure 2 the same after use. Figure 3 shows the principle diagrammatically. The trouble is manifestly with the spikes and ties. Rails laid directly on the ties are sure to cut into the wood, as is proved on steam roads, but street railroads cannot give

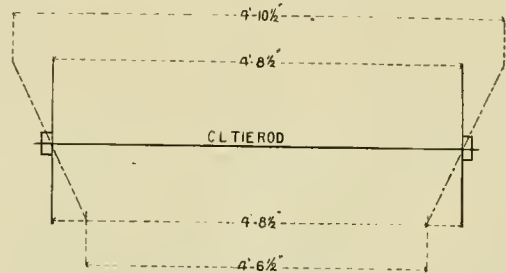

the track and ties the constant attention possible on steam roads, hence, logically they should use something more permanent

Tie plates even if very thin, prevent loosening, provided they are of sufficient area. Figure 4 is of the Wharton tie plate. It has a clip to hold the inside flange,

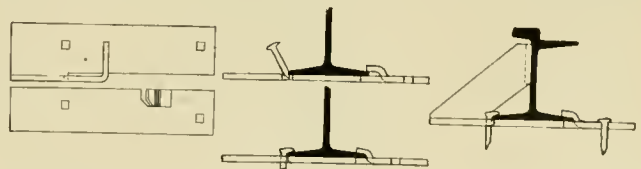

because with a low girder having a wide tram, it is almost impossible to drive a spike at the proper angle. The driving of the spike forces the rail base under the clip. The rail brace (Figures 5 and 6) which is on the same principle, is of one piece, and is intended to do the work formerly entrusted to the tie rod.

CHICAGO residents of Indiana avenue, among them N. W. Powell, F. W. Farwell, F. E. Burley, G. A. Follansbee and B. W. Thomas, are agitating the subject of a conduit electric system on that thoroughfare. A. W. Wright, of the Siemens & Halske Co., wishes the Budapesth system tried.

## THE BARNEY & SMITH MANUFACTURING COMPANY.

The engraving on this page of the REVIEW is not a bird's eye view of a town although a cursory glance might really make the mistake. It is however a village of industry where many hundreds of men spend the most of their waking hours, the plant of the Barney & Smith Manufacturing Company, of Dayton, Ohio.

This company has taken advantage of the late business depression to add materially to their facilities and to make out of hand a new department for the manufacture of street cars. The sill shed in the foreground is the latest improvement, covering 800 by 200 feet of ground space. It is fitted with an electric crane and is perhaps the largest storage shed in the country. The other shops the names of which may be seen on the roofs, in the engraving, are all arranged with the utmost care and provided

Smith, secretary and A. M. Kittredge, superintendent, with William Voss as his assistant. The smooth running of the great establishment reflects great credit upon the management.

THE 11th of January was celebrated by the Sandusky, Milan & Norwalk Electric Railway Company as Emancipation Day—emancipation from the receivership and the many annoyances of the late tightness in the money market. The officers and directors of the road and their wives were invited to the handsome residence of Treasurer A. W. Prout, at Sandusky, and feasted and rejoiced. The feature of the evening was a rhymed report of the treasurer, which contained both truth and poetry. The entire section of the country rejoices with the plucky and earnest builders and managers of the S., M. & N. Electric Railway as does the REVIEW and the fraternity.

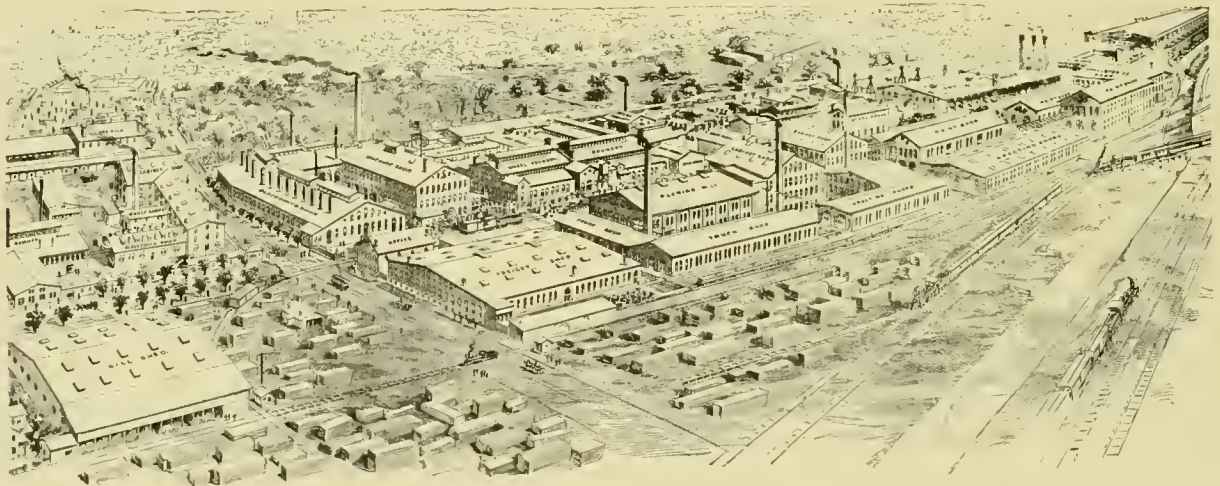

WORKS OF THE BARNEY & SMITH COMPANY.

with all the facilities and tools for best and most expeditious work.

For many years the cars of Barney & Smith have been known to the steam roads and it is with pleasure that we announce their entrance to the broadening field of street railway business. The capacity of the works is now fifteen freight cars a day and forty passenger cars a month of the steam road pattern, besides special work in the line of private cars and coaches, the elegance of which have been unexcelled. The decorators and designers of the company are well known in artistic circles as cultivated and refined and the elegance of the steam car trimmings and paintings bears out the assertion.

It is with no hesitation therefore that the company goes into the street railway field, being assured that the well-known workmanship of Barney & Smith's factory and their indubitable honesty of material will bring to them a share in making of what promises to be the coming industry in car building lines, namely, street cars for rapid transit service.

The officers of the company are E. J. Barney, president; J. D. Platt, vice-president and treasurer; F. E.

## A QUESTION OF ETIQUETTE.

He was of the imperial-and-mustache order, and she was his own Tootsy-wootsy. Both were middle aged, but just as loving as could be.

They stood together on the up-bound track and signaled the car, which dutifully stopped.

"Step up, my dear," he said, grasping her tenderly by the waist.

"No, love, you step up first and I'll follow," she replied timidly, drawing away.

"Step up lively, please," called the conductor, impatiently clutching the bell strap.

"Are you going to step up, Kate?"

"Indeed I'm not, George,"

"Why not?"

"Because it's against the rules of etiquette for a lady to precede a gentleman up stairs."

As the car swept around the curve, they could be seen gesticulating wildly on the up-bound track, while the conductor whispered something about "No fools like old fools."

## VINCENNES VOLTS.

It would be below the dignity of the pretty and aristocratic little city of Vincennes, Indiana, to have anything but the very best street railway line. Vincennes now has 10,000 inhabitants, the majority requiring some method of locomotion.

In 1883 the first street railway company was formed by George and Frederick Graeter. The first line was, of course, on the mule principle. The rail was 30-pound flat iron, and the headway of the cars was not frequent enough to seriously disturb the solemnity of the occasion.

Now it is different.

In 1891, in the month of March, the Vincennes Citizens' Electric Street Railway Company acquired the rights, franchises and properties of the mule line and proposed the electrifying of the system.

The proposition won.

The new company was officered as follows: Allen Tindolph, president; A. A. Walker, vice-president; B. G. Hudnut, treasurer, and Ed. F. Tindolph, secretary and superintendent. During the summer of 1891 of the changes to be made were accomplished and the elegant electric system evolved out of the perseverance, tact and courage of the new managers.

The road now has in successful operation five miles of track, one third double, of standard gauge. The rail is mainly 40-pound T with 50-pound John-

son girder in the <sup>s</sup>down town district. The T-rail was rolled by the Belleville Steel Company. The roadway is unusually level, giving no grades of over 1 per cent. McGuire's trucks, four 19A and two 19B, are used, mounting four closed 20-foot car bodies and two 25-foot open bodies, made by the Ellis Car Company, on wheels made by the Terre Haute Car and Manufacturing Company.

## THE POWER STATION,

is 40 by 55 feet in dimension, and contains one 100-horse-power compound automatic, and one 75-horse-power Junior, Westinghouse, Church, Kerr & Co. engines. The boilers are made by Clift & Co. of Terre Haute, and are two 80's. Roney stokers are used, and Clift & Co.'s feed water heater. The electric equipment is Westinghouse, two generators of 100 and 80-horse-power and one single reduction 20-motor to each car.

There are twelve employes on the road as a minimum and twenty as a maximum. These are divided thus: 2 engineers, acting as foremen; 1 machinist and 1 helper, doing all repairs; the machinist also superintends track repairs; 6 motormen (8 in summer);

conductors, now dispensed with in winter. The road enjoys extensive patronage in the spring, summer and autumn months, and, to encourage riding, a special

10-cent round trip excursion ticket is sold. This has proven very acceptable. Eureka Place, the Fair Grounds and the Base Ball Park are the chief points of amusement on the line. The company hold band concerts and open air mandolin concerts by an orchestra of 50 pieces. All "fete" days are observed at the Fair Grounds, thus adding to the traffic. The line is in the form of a horse-shoe and passes all the relics of the old French settlers, the William Henry Harrison homestead, St. Xavier's Catholic Cathedral, the Pastime Club rooms, and other places of historical interest.

The Tindolphs, father and son, are the moving spirits of the enterprise. Mr. Tindolph, senior, is an old settler, and an experienced transportation man, owning and operating Ohio and Wabash river steamboats. He has occupied governmental positions and is president of the Second National Bank.

Ed. F. Tindolph, secretary and general manager,



E. F. TINDOLPH.

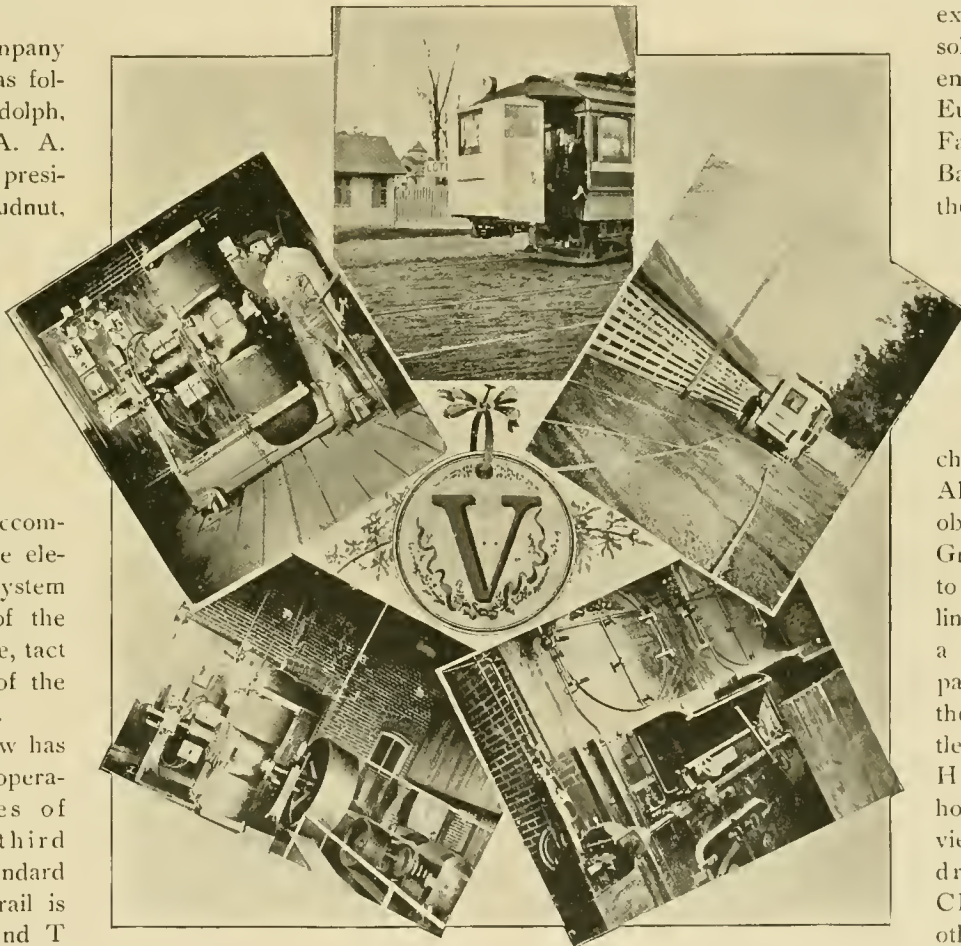

VIEWS OF VINCENNES.

should have the credit of the elegant condition of the road, acting as his own superintendent and having every detail under his control. Although but a young man,

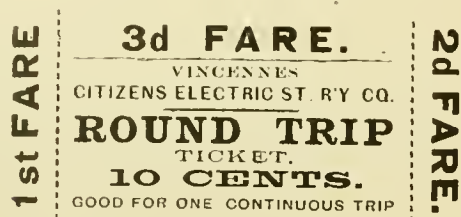

his twenty-three years of experience have been crowded full of business knowledge and of electric lore. We are glad to be able to reproduce herewith his portrait.

### EXPERIENCES OF A SUPERINTENDENT.

By C. P. Young, Superintendent Chattanooga Electric Railway.

#### PART III.

Another thing that is of great loss to electric railroads is the antagonistic spirit that exists everywhere against them by the public. Corporations are always treated with contempt, and it is hard to get justice even in the courts, as juries invariably go against corporations. Now somebody is to blame for this hatred. A street railroad is really a public benefactor. Not only does it increase in value land wherever it passes, but saves time for the citizens and gives employment to an immense number of unskilled laborers. Yet it is looked upon as a public enemy. In analyzing the present and the past I think there is a cause why corporations are branded as heartless. Many presidents and managers have tried unfair means to accomplish their ends. They have been too greedy. They have not treated labor fairly. They have tried too much bulldozing. They have fought the press, and, by not caring for the public rights, they have by their own acts made the public not care for them. Vanderbilt may have been right as a steam railroad man, but never as a street railroad man. War is too expensive, and accomplishes less than diplomacy.

In operating the cars on most roads a great waste exists. They are in the habit of running all day the same number of cars in the various divisions, notwithstanding that travel is heavy between 6 to 9 a. m. and 4 to 7 p. m., while from 9 to 4 there is generally light travel. I am a great believer in trippers and trailers, and every division should be treated according to its wants. If travel becomes heavy or light, lengthen or shorten schedule, but by all means have equal distance between, whether it be one or thirty minutes. Every trip a car makes means a certain outlay of money, but not always an income, and no car should make a trip in vain. Too fast schedule, and being too particular about time, costs money. The motorman is compelled to run too fast and (what I call) rawhide his car. By so doing, he consumes too much current, wears his motors out quickly, increases

liability to accidents, and, worst of all, cultivates a tendency to be reckless, eventually becoming a dare-devil, utterly unfit to have charge of human lives and valuable property.

We will now consider the motor and current question. There is no machine invented by man that is more exposed to the enemies of its existence than an electric street car motor. Dirt, dust, water, jars and jolts, constant starts and stops, are the surrounding conditions. Then the motor is generally handled by an ignorant man, and, perhaps (as is often the case), never was right when first started, and then all wonder why the car gives out and repair and supply bills are so heavy. A pound of energy is not the result of nothing, but of something, whether it be wheat and meat in a man's stomach, hay and corn in a horse or coal under a boiler. Suppose, for illustration, we take two roads with the same system of boilers, engines, dynamos, motors, track, hills, curves and crossings. One road is in the hands of an expert superintendent who understands his business, and who educates his men to know as much, if not more, than he knows himself. The other road is in incompetent hands. It is a known fact that 20 per cent of all cars are standing still either letting on or off passengers or waiting at end of line. This leaves 80 per cent in motion. Now, on the properly managed road, perhaps half of the cars in motion are rolling along without current and by momentum, while, on the other, on the badly managed road, the full number of cars in motion are using current. In the good station the consumption of coal, water, and strain of engines, belts and dynamos are about one half what they are in the station of bad management. Suppose now the expenses for coal, water, repairs and maintenance of the station for the good road is \$2,000 per month, the bad road will cost at least \$3,000,—a great difference. Nor is this all. On the bad road the motors, wheels and brakes will be very short lived, which means a great loss. Then on the good road feed, tap and ground connections are watched with a hawk's eye. The slightest defects are cured immediately, no matter where they appear.

We will now consider the various departments: Power-house, machine-shop, car-barns, day and night men, track and overhead work, and their crews, motormen and conductors—their management and discipline,—supply and accident department and officials.

The power-house is divided into four divisions: boilers, engines, dynamos and switchboards. A good many financiers think that any man that is strong and dirty, and that can handle a shovel, is all right for a fireman. This is a great mistake. Firing a boiler right and scientifically is an art that requires a high grade of intelligence. A fireman should be well informed on water, coal, combustion, expansion, contraction, evaporation, and the whole science of steam, and, above all, honest and faithful. A poor and ignorant fireman may take the best built and latest set of boiler, with the best steam fittings, and depreciate their value immensely and then use up tons of coal and vastly more water in a year than a good one, whose wages are twenty-five or fifty cents more per day

for the good fireman as against the bad one. Yet the good man, when the year is up, has his boilers in better shape, his steam-fittings, grate-bars and all other parts in good order and the coal and water bill largely in his favor. The engineers in charge of the plant should be good machinists and electricians, as well as good engineers; they should be able to repair any damage and know all about dynamos, switchboards, heaters and pumps, and also be thoroughly familiar with all the lines, cars—their weight, size and make. They should always be informed in regard to number of cars that are out, and if any extra cars are to be sent, and time for same. They should study economy in oil, water and all other material; be dutiful, conscientious and sober; neat personally, and take pride in keeping their engine-room clean and have a place for every tool and every tool in its place. And here let me add that a railway engine-room should never for one moment be left alone, but some one that understands everything should be there ready in case of trouble. You can never tell what may happen the next moment. A short circuit, a ground, or any one out of a thousand things may happen. The engineer really carries a greater responsibility than financiers realize. Electric railroading is a profession, the last one launched forth upon the sea of human activity, and the sooner investors and directors of electric railroads find this out, the better it will be for themselves and the traveling public, as well as employees.

## THE TEXAS STATE STREET RAILWAY ASSOCIATION.

On December 15, 1893, several representatives of Texas street railways met at Waco and concluded that the common weal demanded a union in which would lie the strength resulting from the interchange of ideas on various economic subjects. The temporary officers selected were: A. Zintgraff of the Denison Street & Belt Line Railway Company of Denison, president, and S. A. Hobson, of the Waco Electric Railway and Light Company, Waco, secretary, and a meeting called for January 24, 1894, at Austin, at which permanence could be considered.

The first annual meeting was therefore held at Austin on January 24, and with a representative attendance; the following officers were elected and committeemen appointed:

President, William H. Sinclair of the Galveston City Railway, Galveston;

Vice-president, J. K. Urie, of the Austin Rapid Transit Company, Austin;

Secretary and treasurer, S. A. Hobson of the Waco Electric Railway and Light Company, Waco. The directors are:

W. H. Weiss, San Antonio Street Railway Company;  
A. W. Childress, Queen City Railway Company of Dallas;

W. H. Sinclair, and J. K. Urie: committee on membership, Carl Drake of the Laredo Electric & Railway Company, Laredo, J. K. Urie, A. W. Childress and C. A. McKinney of the Houston City Railway Company, Houston.

The constitution was adopted and the next meeting set the third Wednesday in January, 1895.

The delegates were entertained with great hospitality by Mr. Urie of Austin and Mr. Drake of Laredo. A carriage ride to the great Austin dam and a pleasant excursion up the lake by steamer were the daylight festivities. In the evening a royal banquet was spread by Mr. Curtis of the Driskill Hotel and demolished by the guests.

Altogether the occasion was a most pleasant and profitable one and the Lone Star association will surely be a bright light to the firmament.

COL. WILLIAM H. SINCLAIR,

the president elect of the new association is almost too well known to require mention. Suffice it to say that there is not a street railway man in America that does not know the strong and kindly face of Col. Sinclair. At the age of 55 Col. Sinclair has a most successful and happy career to look back to. Born in Ohio, a brave soldier and officer in the federal ranks and an early post bellum settler in Galveston, Col. Sinclair has

been one of the most active and untiring agents in creating the new South. The Galveston road owes its excellence to his ability and the Texas association will find in him a stout ally and competent head.

SECRETARY S. A. HOBSON,

is a practical street railway man, having worked his way up from the ranks and at the age of 23 finds himself secretary and superintendent of the Waco Electric Railway and Light plant.

His first experience was as conductor on the Wyatt Park Street Railway of St. Joseph, Mo., afterwards working in the repair shops, and from there was appointed cashier. He early developed a talent for construction and was appointed to superintend the building of the Jule Street extension of the Wyatt Park Railway, this was in the summer of 1889. He was soon afterwards made superintendent of the road, at the age of 19; this place he filled until March 1891, when he resigned and came to Waco, Texas, and took charge of the construction of the railway and light plant of The Waco Electric Railway and Light Company, which now controls 6,000 incandescent lights, 200 arcs and ten miles of railway.



W. H. SINCLAIR.



S. A. HOBSON.

## POWER SELLING AND UNDERWRITERS' RULES.



ELECTRICAL department of the western insurance association has been undergoing a thorough overhauling during the past six months, and among other things the rule prohibiting the use of grounded 500-volt circuits inside of buildings has been brought out of its resting place and an attempt is being made to enforce it.

Hundreds of power users in the smaller towns have been made to feel the effect of this action, which practically forces them back to the use of the antiquated small steam engine (which by the way is no small fire risk), or necessitates leaving the "old line" insurance companies.

The following letter is self explanatory.

CHICAGO, Jan. 30, 1894.

WILLIAM H. MERRILL, JR.

Electrician Chicago Fire Underwriters' Association, City.

DEAR SIR:—

In view of the fact that the association which you represent has seen fit to refuse all risks on buildings containing motors run from street railway circuits, and as the danger of such circuits in buildings seems to us not to be such as to warrant this ruling, we would be pleased to give space in our columns to a discussion of the practice from both standpoints, and therefore request a statement of your position and the reasons therefor. We have always taken the position that such circuits when run according to proper rules are practically as safe as any class of electric light or power wiring, and that while special rules should be followed in their installation, they should be "inspected" instead of "prohibited." It is to our mutual interest to settle the question in the right way, whether it be according to our present ideas or yours. We would request that your presentation of the case include a statement of the fires caused by such circuits as far back as your records will permit, and that if possible a detailed enough account of any such fires be given, so that it can be judged whether they would have occurred had the wiring been done as carefully as that on arc light circuits and a proper system of inspection been maintained. Enclosed please find pages 355 and 356 of our June, 1893, issue which contains statements from the Omaha and Sioux City Street Railway Companies, W. R. Garton, of the Garton-Daniels Electric Company, C. F. Cook of the Westinghouse Company, Chas. Vint and C. K. Mac Fadden, Chicago, all of whom uphold our position. Also please find enclosed a clip from the London Electrical Review, reprinted in our September issue, in which the grounding of circuits is advocated from an entirely disinterested standpoint and their increased safety pointed out.

Very truly yours,

STREET RAILWAY REVIEW.

Mr. Merrill was glad of the opportunity to present the insurance mens' side of the case and furnished us the following reply:

EDITOR STREET RAILWAY REVIEW:—

I have read the articles "Grounded Circuits and Fire Insurance" and "Plain Argument in Favor of Grounding," published in the June and September issues of the STREET RAILWAY REVIEW. I have also read other articles and many

letters by railway men and electrical engineers regarding the practice of operating stationary motors by current supplied from trolley wires. Among all the interested authorities which I have seen quoted I cannot find one that advocates this system from an engineering standpoint or who pronounces it good engineering. In fact they all admit it weak. One insists that a lightning arrester should be attached to all circuits of this kind entering buildings, another that great precautions should be taken in insulating, supporting and fastening the conductors, another that the fusible cutout should be carefully looked to, another that a sign reading "danger" should be placed near each motor and the mounting and bases very carefully insulated, another that the ground connections should never be made on a gas or water pipe, another that "unusual precautions" should be taken in the installation, another that "proper" precautions should be taken, another that a circuit breaker and a first-class lightning arrester should be put in, in addition to switches, fuses, etc., another that only "the best" motors should be used on this class of circuits and the insulation of the fields and armatures should be carefully watched and kept at a high point, and so on ad infinitum. Each has his own "precaution," which if not explicitly followed will make the operation of the machinery "extremely dangerous" and no two of them suggest exactly the same "precaution." All of this while it does not solve the difficulty serves to show that the danger is there, if any proof of this kind is needed.

Admitting for the moment, that by concentrating the whole intelligence of the electrical engineering profession upon this problem, that it might be possible to operate a stationary motor on a 500-volt grounded circuit for an hour or two, without burning any property or killing anybody, and we find that the following precautions should be observed in the installation: (1) A reliable circuit breaker should be introduced where the tap is made and this instrument should be examined every week to make sure its reputation may not be affected. (2) A lightning arrester, which must also be "always reliable," (though exactly how no one has yet stated), must be attached to the line before it enters a building. (3) A fusible cutout employing either a five inch break between terminals, a bridge or a magnetic blow out, should be introduced on the circuit immediately it enters the building. The fusing of this protective device should be most carefully looked to after every accident, and no nails or pieces of barbed wire fence should be employed in place of fuse metal. (4) A knife switch giving a proper break should be introduced on the circuit either directly inside or directly outside the service entrance, by which the current may be entirely cut off and the wiring and apparatus disconnected. Both the switch and the cutout should be mounted on marble or slate bases. (5) The wire used must be of the "very best," must be supported wholly on glass insulators, kept at least eight inches from gas and water pipes and awning frames and structural iron work, and all other conductors and conducting materials. In fact, provided with a little house of its own, eight inches square throughout its whole run. (6) Ground connections must never be made inside buildings and preferably never on gas or water pipes. (7) The motor must be set up and insulated in "the most approved" style and must be of "the very best make," etc., etc.

And so on; "the very best" always means "the very cheapest" and "the most improved" is always "the easiest". Waiving all these however, how many motors operating from trolley roads have ever been installed in accordance with the above



rules? How many have observed half of them? Is it not impossible to carry them all out to the letter, (I am not sure but what I have omitted some very important ones even now), and would it not be cheaper to construct a metallic circuit or operate from a motor generator than to try? And would it not be better engineering? Would it not be safer? A 500-volt current is one of the hardest currents to handle. It combines the disadvantage of the series arc current in its high voltage with that of the low potential systems in its great heating effects. It should certainly be conducted through the safest channels engineering skill can devise. Is this done in the system under discussion? I think not. In actual practice, where we meet the man whom the STREET RAILWAY REVIEW told of, who ran his building circuit of bare wire because the trolley wires were uninsulated, and the man the Underwriters' fire reports tell of, who soldered his ground wire into the gas meter connection, we must plan our power systems so as to prevent the minor daily mistakes of construction men giving us serious trouble. If electricians wish to do nothing to check the steady growth of the electrical industry they should provide it with healthy nourishment. Planting such weeds as this system in its path will never make the cow give milk."

We could forgive the mixed metaphor at the end, about the cow and the weeds, if Mr. Merrill had only brought facts to prove that the system has actually proved to be such a mammoth weed as he represents. It is indeed strange that such circuits should be in daily use on hundreds of cars and around hundreds of car barns and offices without burning up every plant in the country within a week, if the claims made are correct. It will be noticed that our request for a list of fires caused by such circuits is not complied with. This shows that there is something seriously missing somewhere in the chain of practical facts necessary to prove the enormous fire risk on such circuits which warrants their prohibition. We expected that underwriters would go into the subject from an underwriters standpoint and bring up facts and figures to prove the danger of certain risks. That is certainly the most business like way to go at it. Instead, we find a lot of argument based principally on theory and on an obsolete precedent. In the early days it was difficult to keep the insulation up on metallic circuits, to say nothing of those which were grounded. The art of insulation progressed and knowledge of electricity increased until electricians did not regard grounded circuits with the former horror. It was demonstrated that grounding was good engineering on three wire systems. To the grounding of 500-volt circuits is but another step.

However, let us consider Mr. Merrill's statement, item by item. In the first place we do not know how Mr. Merrill defines "good engineering," but it seems to us that any safe system of power distribution which allows of the use of electric motors in places where expense would otherwise prohibit them, can be placed under that head. Engineering of any kind is as much a financial problem as anything else. The majority of stationary motors run from railway circuits are in small towns where separate power circuits are not able to pay expenses. This being the case it is certainly "good engineering" to run stationary motors from railway circuits if it is safe,

and this brings us back to the real question at issue. Mr. Merrill then goes on to cite the various precautions which are suggested by various electrical engineers and which should be taken in the installment of such circuits, "all of which \* \* \* goes to show that the danger is there." Does Mr. Merrill mean to say that there is not danger in every electric light and power circuit. Of course the "danger is there," but that fact does not preclude the possibility of safely operating such circuits. Referring to the suggestions made by the various electrical engineers he says, that all of these (suggestions) do not solve the difficulty. What on earth were they made for then? Were the men who made them talking just for the sake of making a noise or did they mean what they said. We were laboring under the impression that these men (the majority of whom know what they are talking about) made those suggestions because they believed that by having them carried out the circuits in question are made safe. If Mr. Merrill's reasoning is logical it is not safe for engineers in any department to specify safety precautions, because it would inform the insurance companies that there was danger and the risk could not be taken.

Then follows a set of rules which are very good in the main, but as they are evidently not given in good faith, they will perhaps bear modification. "How many motors operating from trolley roads have ever been installed in accordance with the above rules?" We would ask in return how many inside incandescent circuits outside of the large cities correspond to the specifications in the underwriters rules. If Mr. Merrill cares to make a tour of the smaller towns and condemn all risks having electric wires not installed according to underwriters rules, he will condemn about seventy-five per cent. If things are to be worked out on the basis of what actually is at present very well, but let the rules be enforced all along the line.

However, the only basis on which to argue the matter, is on the premise that the insurance rules are to be enforced. If rules can be enforced in regard to wiring of arc and incandescent circuits, they certainly can be in case of railway power circuits. We think that insurance companies are very foolish to accept any electrical installations without inspection. If this were done, a check would be put on the "daily mistakes of construction men." Supposing however, that there is no inspection, we think that the lineman will exercise more care, knowing that one side is grounded, than if he is depending partly on the insulation of the other side. A railway circuit installed with common sense precautions, is not comparatively as dangerous as at first appears. As an actual fact, arc circuits are generally grounded more or less heavily at various points, as anyone who has worked on arc circuits knows. This makes them practically worse than railway circuits. A well known engineer once said in private conversation that the most dangerous thing from an insurance standpoint in the whole field of electrical practice is the two wire incandescent system. Thousands of lamps, fixtures, drop cords, etc., are fed from one station. If (say the positive wire) becomes accidentally grounded,

at any point in the system, it reduces one half the insulation of the negative side of the entire system and a ground on the negative side, then of course means a prospect for a fire. The same is true to a greater degree of the non-grounded 500-volt circuit.

To sum up:—

1. The 500 volt grounded circuit, has been in use for several years in thousands of cars, hundreds of car barns and hundreds of buildings. The wiring has not been of the best, but the results do not show that such circuits are comparatively so dangerous as to warrant their prohibition.
2. Such circuits are the most simple. Increased complication always means increased danger.
3. If wiring rules are enforced they can be enforced as regards railway circuits. Such circuits are few and easily inspected.
4. The most able and practical electrical engineers admit the safety of such circuits, if properly installed. Prohibiting them is like prohibiting steam boilers, because uninspected boilers sometimes explode.
5. Prohibition of these circuits practically means the prohibition of electric power in many places where the rule applies.

convention again. The actions of the "old line" companies which are based on actual statistics are business like and unobjectionable. It is such arbitrary theory-based rulings as the one here discussed that will build up mutual insurance.

### W. F. ADAMS.

The newly elected president and general manager of the Chattanooga, Electric Railway, is a self made man and a splendid type of the young men that are making the South what it is commercially.



W. F. ADAMS.

Mr. Adams is now forty years of age, a Mississippian by birth and education, and a gentleman of great energy and resource. Beginning with absolutely nothing, he has build up for himself a wide reputation in manufacturing lines, and now enters the street railway fraternity, into which all are glad to welcome him. His first business experience was as a clerk, then as an



RUINS OF THE ATTEBORO, MASS., POWER PLANT.

There seems to be no great prospect that the underwriters will soon change their ruling. One of our most progressive managers hits the nail on the head when he says: "Before giving in, I shall co-operate with the owners of buildings using our power and try and find insurance companies outside of the association, who are willing to accept the risks. The so called "old line companies" are getting more arbitrary every year, and I am now looking into mutual insurance with a view to placing the insurance on our plant with such companies. I learn that many other roads are being forced to do the same thing, by their unjust and illiberal treatment."

At present the majority of policies of the "old line" companies are so worded that were they literally interpreted nothing could be got on them in ninety-nine cases out of a hundred. Mutual insurance is the only recourse and it is gratifying to know that it will be brought up at next

express agent, and finally at the age of 22 with a little money and lots of energy, he began manufacturing at Rienzi, Miss. Four years later, business tact and industry so built up his success, that he removed to Corinth, and established the W. T. Adams Machine Company, making boilers, engines and general machinery. This plant is now one of the best known in the South.

Mr. Adams is a practical man as well as a financier and the best that we can wish him is, that his success in the street railway field may approximate the success that has attended every previous effort. The Chattanooga electric railway, is to be congratulated upon its executive head, and the fraternity upon the accession of such a member.

OUR illustration above is of the ruins of the Attleboro, Mass., power house, from a photograph taken expressly for the STREET RAILWAY REVIEW.

THE OHIO BRASS COMPANY OF  
MANSFIELD, O.

The Ohio Brass Company, of Mansfield, O., is not a novice in the manufacture of street railway supplies. For several years its entire output has been handled by a supply house, but now the company has concluded to sell its own goods.

The company's plant is complete in every detail, including a machine shop and foundry, a completely furnished

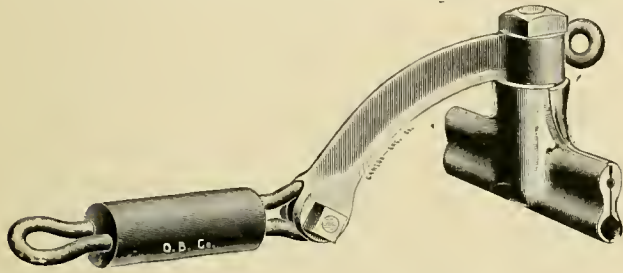

SINGLE CURVE PULL-OVER.

laboratory for testing both material and products and every modern method of making the best grade of goods in the most workmanlike manner. The testing instruments are from Queen & Company, and the Ohio Brass Company's goods are all rigidly tested by them. An illustrated catalogue of all the company's goods will be issued about February 20. It also stands prepared to make special work from designs.

As an advance sheet we show one or two devices from the forthcoming catalogue.

The single curve pull over fitted with type W trolley clamp is here illustrated. The yoke and adjustable cone are made in one malleable casting and insulated from

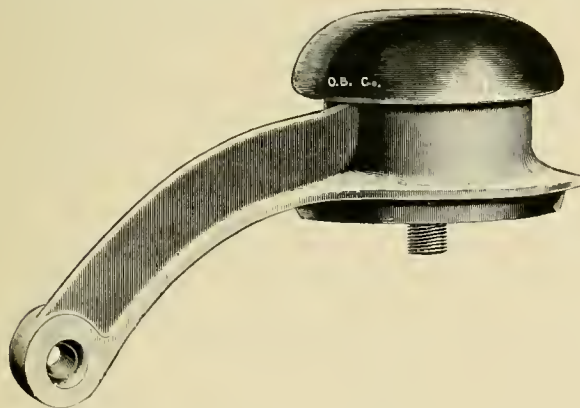

SINGLE CURVE HANGER—TYPE W.

span-wire by the small Mansfield strain insulator. This pull over was designed to meet the demand for a curve insulator of minimum weight for use on the smaller sized trolley wires. It is strong enough however to support No. 0, B & S trolley wire. The double curve pull over is similar in design and detail to the single curve pull over but has a double yoke and double insulation. The curve hanger bodies are made of the best malleable casting, giving strength and lightness. The insulating pieces are moulded from a special compound and the top and bottom pieces are dovetailed together and into the hanger

body to prevent surface leakage. The iron casting which is moulded into the insulating cap is larger than the inside diameter of the collar, thus insuring strength. All insulator caps and washers for type W hangers are interchangeable.

The Mansfield strain insulator is a superior device. The medium size has a breaking strain of 10,000 pounds and consists of two steel staples five inches long,  $\frac{3}{8}$  inches

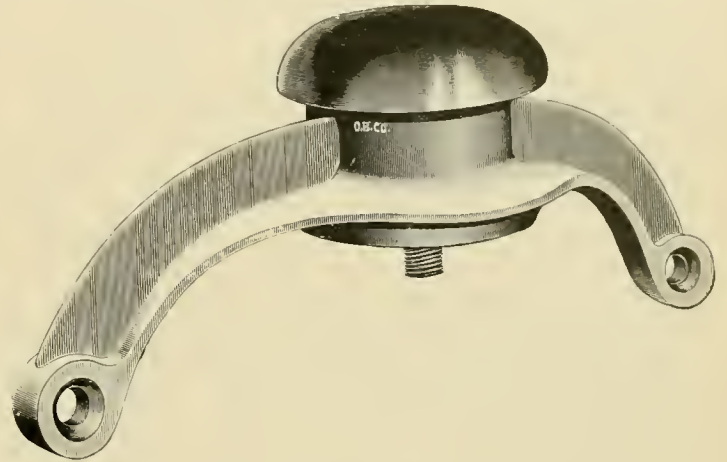

DOUBLE CURVE HANGER—TYPE W.

diameter, and moulded into the insulating compound. It is seven inches over all and weighs less than three-quarters of a pound. Its insulating properties are guaranteed under the severest strain.

The personnel of the company is: E. T. Cooke, president, F. B. Black, secretary and manager and C. K. King late of the Ansonia Electric Company as special salesman in the electrical department. The company has bright prospects for an excellent and increasing business.

THE PITT FOLDING GATE.

The folding gate has become almost a necessity on rapid transit lines and its importance in preventing accidents is such that its use is on the increase daily. William R. Pitt, of 202 Fifth avenue, New York, was one of the

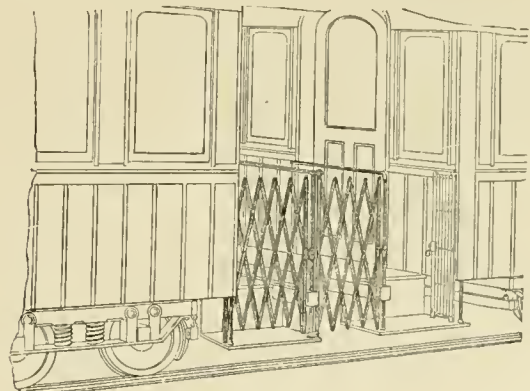

PITT FOLDING GATE.

pioneers in the folding gate business and to him are due many valuable improvements in this style of gate. The Pitt patent gate, made by the Composite Iron Works of New York, is made of a fine quality of channel steel and

great care is used in the details of construction. These facts have helped to make the Pitt gate one of the standards of quality. As a gate for use between trailers, where unusual stretch is required in going around curves, it has been in use for years in Philadelphia and Baltimore. It has stood the test of time and it will not be amiss if it is specified for new cars.

#### THE STANDARD SWITCH THROW.

The above named device has recently been installed at the corner of Ninety-second street and Commercial avenue, on the South Chicago City Railway, by the Milwaukee Switch Throw Company. It consists of a simple triangle of mitre steel, pivoted at one corner and thrown either way by a bar on the moving car. This triangle, which has an underneath connection with the switch point,

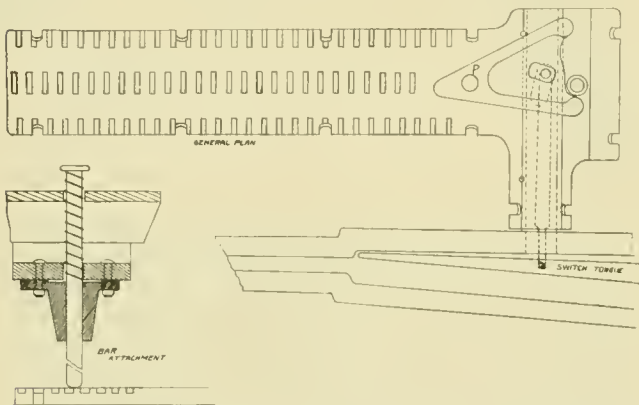

is mounted on a base plate, roughened to accommodate general traffic. The shifting rod on the car when pressed down strikes the track M, or N, as the case may be, and finally one or the other side of the triangle, thus throwing the switch. The only exposed moving part is the triangle. It can easily be kept in working order by the man who oils and salts the curves. The time saved by all the cars on a road in a day, amounts to considerable.

#### MIDWINTER FAIR TRAFFIC.

Saturday, January 27, 1894, will be long remembered by the enthusiastic thousands, who celebrated the opening of the MidWinter fair, at San Francisco. Unquestionably a grand success, beautiful to the eye and satisfying to the mind, the Fair opened with 72,248 spectators. The parades of the day, the opening exercises, and the features of the display have been told elsewhere. It is the purpose of the REVIEW to give honor to the magnificent service rendered by the intramural facilities of San Francisco.

To begin with, street traffic was not interrupted. Experienced men, stationed at points where the parades crossed the car lines, regulated the traffic, and allowed the cars to shoot by, at regular intervals, when the line was broken for that purpose. The spectators could thus see both parade and exercises.

It was a great day for the Consolidated Market Street Cable. Manager Stein says that his lines delivered 8,000

persons an hour at the Park, or 64,000 in all. The crowd began to leave at 5 p. m. and by 6:30 all had conveyance home.

On all lines, both direct and feeders, extra cars were placed, ranging from one-half to three times more than usual. Every car owned by the company was put in service. The Metropolitan Electric carried 20,000 passengers, and the other lines not direct, did a good business.

#### LOOK OUT FOR HIS KIND.

A smart accident insurance swindler, set up an office for the German Mutual Benefit Association, of Peoria, Ill., at Kansas City, Mo., some time ago, and insured a large number of street railway employes, at \$5 per membership and \$1 to \$2 a month thereafter. Last November, an injured conductor attempted to get his indemnity, but could not. This aroused suspicion, and an investigation of the agent's office and effects, showed nothing but leaves. He had absconded with all the fees and emoluments. The police of several towns are looking for him. His name was F. C. Baird.

#### BIG FIRE AT CINCINNATI.

The splendidly equipped machine shops and the car barn of the Cincinnati Consolidated Street Railway Company, at Avondale, burned February 2, totally destroying the buildings and eighty cars, with all machinery. The loss is reckoned at \$175,000 as follows: on the cars, thirty motors, and fifty trailers, mostly open, \$125,000; on the building \$25,000, on the machinery \$25,000. The building was 250 feet long, one and a half stories high, with a basement. Bad insulation is the assigned cause, assisted by the oil soaked and highly inflammable construction.

The insurance was \$150,000.

#### THE BIDWELL TROLLEY HEAD.

A trolley harp and bearing which combines several valuable qualities has been successfully experimented with for some time past by C. S. Bidwell, electrician of the Ashtabula Rapid Transit Company. The wheel is

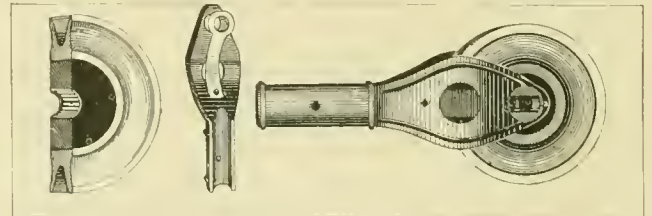

on roller bearings. The fork is in two parts. Side play is taken up by flat springs riveted to the harp. This with the roller bearing insures a long life for the wheel as far as journal wear is concerned. The harp is very easily taken apart, making a change of wheels easy. The rollers of the bearing can of course be used several times.

## AMERICAN STREET RAILWAY ASSOCIATION.

Executive Committee Meets at Atlanta, and Makes Arrangements for the Annual October Convention.

The executive committee of the American Street Railway Association met on January 24, at Atlanta, Ga., to make arrangements for the annual convention, which convenes in that city October 17, 18 and 19, 1894.

There were present, the president, Henry C. Payne, and William J. Stephenson, Lewis Perrine, Jr., Thomas H. McLean, W. Y. Soper, E. S. Goodrich, and the secretary, W. J. Richardson.

Letters stating their inability to be present, and regretting their absence, from D. F. Longstreet, James R. Chapman and Edward Whitaker, were read.

The question of employing a statistical secretary was discussed, but action deferred until after the convention.

The formation of a "Street Railway Institute," which was suggested at last convention, was also laid on the table, in consideration of the financial condition of the country.

The following selection of subjects for reports at next convention was made:

### REPORTS.

- "Can the T Rail be Satisfactorily Used on Paved Streets?"
- "Suburban Electric Railways."
- "Mail, Express and Freight Service on Street Railway Cars."
- "A Standard Form for Street Railway Accounts." By H. I. Bettis, Atlanta.
- "The Best Method of Treating Accidents and Complaints."
- "Street Car Wheels and Axles."
- "The T Rail Construction of the Terre Haute Street Railway Company." By M. F. Burke, Superintendent.
- "Street Railway Mutual Fire Insurance." By Lewis Perrine and the Secretary.

### DISCUSSIONS.

"Transfers and Commutation." To be opened by C. K. Durbin, general superintendent, Denver Tramway.

On the suggestion, by letter, of Superintendent McClary, of Birmingham, Ala., it was decided to hold an executive session on Thursday morning, October 18, and that members be urged to come prepared to furnish data and participate in discussion.

It was decided to request committees to limit their reports to twenty minutes each.

### HEADQUARTERS.

The Aragon Hotel was selected as headquarters hotel, and Machinery Hall, at the Exposition Grounds, was chosen as place for exhibits.

### ENTERTAINMENT AT CHATTANOOGA.

The street railway friends at Chattanooga, Tenn., presented a request that the visiting delegates to the October convention, and their ladies, visit Chattanooga on Friday,

October 19, and stated that arrangements had been made to keep the famous "Lookout Inn," on Lookout mountain, open until after the convention, to accommodate the Association. The committee voted to accept the invitation and date, and one of the most delightful side trips ever enjoyed by the Association will be the result.

## A SAN FRANCISCO ACCIDENT.

The worst street railway accident on the coast since the draw bridge disaster at Portland, Ore., occurred January 27th, on the San Francisco & San Mateo Street Railway line, on Chenery street, San Francisco. The line at that point is a combination of a heavy grade and curve. The motorman of the ill-fated car lost control of the brake and the car dashed down the hill, left the track and was stopped by a collision with a side pole, wrecking the vehicle and injuring 29 passengers, four of them fatally. The car was heavily loaded, carrying as nearly as is known certainly, 95 passengers, mainly visitors to the Midwinter Fair grounds, on their way to witness the fire works display at the exposition. The last passengers taken on were 25 employes of the line, who crowded the platforms



(From photograph of wrecked car.)

and the steps and bumpers. The grade on this hill is approximately 11 per cent and was the scene of a thrilling occurrence of a like nature at the time the road was first commissioned. This former accident however, did not seem to teach the management discretion, and the above mentioned load of nearly 100 persons on such a grade, amounts to little less than criminal carelessness. Knowing that the events at the Midwinter Fair would call forth increased traffic, more cars should have been run and extra precautions taken. That neither was done seems evident.

The motorman's statement to the manager is in part as follows: \*

At Randall street I stopped to discharge a passenger, and then proceeded down the hill. When setting brakes, inside brake failed to work. I rang for conductor to set rear brakes, as the car was gaining speed rapidly. I threw the reverse lever over so car would generate current and choke down. Failing to generate soon enough I applied the current which checked the car, but my fuse blew out and car got away from me. Brakes were in good order up to time of accident."

The car is thus described by President Joost; length 32 feet, width including steps 9 feet. There is no enclosed space for the motorman and with his platform crowded he can not work to advantage. The company claims that all

its motormen are experienced and used to heavy grades, thus seeming to be willing to back the man's judgment. At the time of the former accident seven persons were injured and it is said that danger is augmented by the fact that children attending an adjacent school use the tracks as a toboggan slide, using boards on the rails, rendering them as smooth as glass. This second lesson in safety certainly should not need repetition.

### THE LACONIA CAR COMPANY.

Announcement of the Entry of an Old Concern into a New Field.  
—Its Facilities and Prospects.

Laconia, in the State of New Hampshire, is not only famed in song and story, as the center of one of the most picturesque spots in American Switzerland, but as a more

arate quarters. Each department is interconnected by tracks, to facilitate the handling of work from one another. The areas of the department shops are as follows: mill 60 by 100 feet; paint shop, 50 by 270 feet; cabinet shop, 40 by 150 feet; blacksmith shop, 40 by 150 feet; gray iron and wheel shops, 40 by 200 feet. The capacity of the latter department is 100 street car wheels a day. In addition to these enumerated departments, the Laconia Company has a malleable iron mill, 150 by 200 feet in dimensions, one of the most complete in New England. This department makes castings for the West End Street Railway Company, the General Electric and other concerns.

The lumber yards and dry rooms of the Laconia Company, of course are large in proportion to the rest of the plant and their own special cargoes of

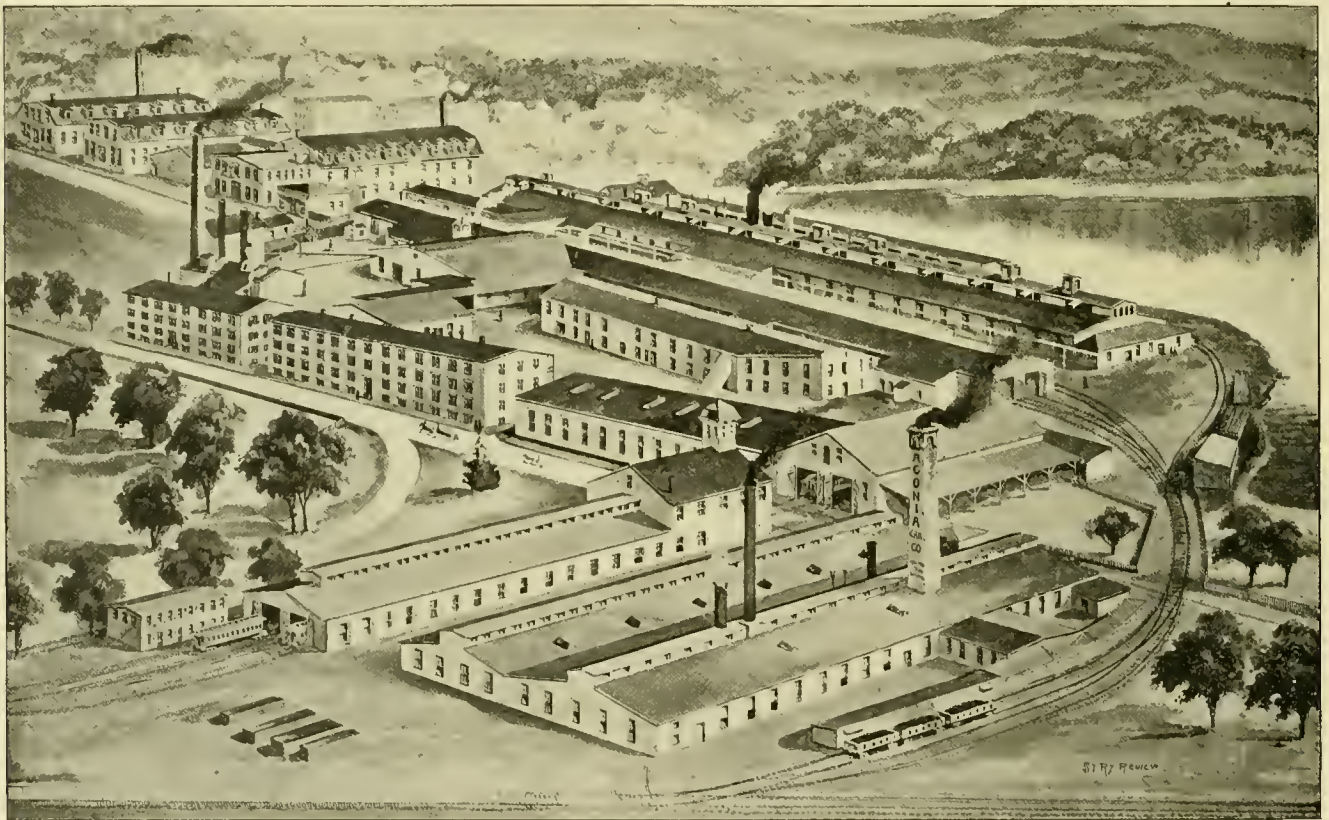

WORKS OF THE LACONIA CAR COMPANY, LACONIA, N. H.

than passing distinction, in the annals of New England's commercial prominence.

Its best known industry is without doubt the Laconia Car Company. The general view of which we take pleasure in presenting on this page.

For many years, in fact, ever since the beginning of extensive railroad building, the Laconia Car Company has been in the field of steam road work. It was founded in 1850, and with nearly fifty years growth and experience it is needless to state that the equipment of the factory is complete to the last detail.

As will be noticed by the reader, in even a casual glance at the accompanying engraving, the different departments of the work are provided with spacious, sep-

Oregon pine are brought direct to the works. Seven hundred men are employed at the works, all skilled in their various crafts, and cars of special designs may be built with assurance of the best material and workmanship.

The president of the company is Perley Putnam, a man whose executive ability has long been recognized; the secretary and treasurer is W. E. Putnam.

The street railway sales department is placed in the competent hands of F. E. Huntress, of 8 Oliver street, Boston, who will take pleasure in affording any one interested the most complete information as to price, style and time of delivery, the three main points of excellence requisite in car buying.

## STREET RAILWAY PATENTS.

ISSUED JANUARY 9, 1894.

Method of laying railway rails in paved streets. George C. Warren, Utica, N. Y.....	512,343
Street railway crossing. William C. Wood, Brooklyn, N. Y., assignor to the Lewis & Fowler Girder Rail Company, same place.....	512,351
Trolley cut out. Melancthon Hanford, Meriden, Mass.....	512,373
Closed conduit railway. Charles J. Kintner, New York, N. Y.....	512,444
Electric railway current collector. Eben M. Boynton, West Newbury, Mass.....	512,535
Street pavement. Bedford P. Thiebaud, Springfield, O.....	512,568
Street pavement. Bedford P. Thiebaud, Springfield, O.....	512,569
Car brake. Harry Thompson, Brooklyn, assignor to himself and John F. Ambrose, New York, N. Y.....	512,588

ISSUED JANUARY 16, 1894.

Rail bond connector for electric railways. Herbert R. Keithley, Chicago, Ill.....	512,711
Life saving device for tramways. Louis Martineau, La Roche, France.....	512,836
Rail joint. Charles L. Wheeler, Marion, Ind.....	512,852
Trolley wire insulator. Henry H. Luscomb, Hartford, Conn.....	512,888
Battery system for electric railways. Leslie B. Rowley, Ashland, Wis.....	512,907
Cable car transfer device. John T. Schweizer, Wilmington, Del., and Jacob H. Burger, Philadelphia, Pa.....	512,910
Signal lights for street cars. James A. Trimble, New York, N. Y.....	512,921
Electric railway trolley. Walter Van Benthuyzen, New Orleans, La.....	512,923
Cable grip. Frank T. Hogg, Brownsville, Pa.....	513,014
Electric railway trolley. George W. MacKenzie, Beaver, Pa., assignor of two-thirds to Thomas C. Sloane, and Moses B. Sloan, same place.....	513,022
Car brake handle. Austin B. Collett, Lynn, Mass., assignor one-half to John S. Baker, Beverly, Mass.....	513,033
Trolley oiling device. James R. Labadie, Ecorse, Mich.....	513,067

ISSUED JANUARY 23, 1894.

Trolley wheel. Charles C. Bourdreaux, Peoria, Ill.....	513,076
Street or station indicator. Hugo R. Kuersten, Chicago, Ill., assignor to himself and Albert J. Pauli, and Peter Sedi, Menominee, Mich.....	513,117
Rail brake. Henry L. Simmons, Wickes, Mont.....	513,207
Motor support for motor trucks. Walter S. Adams, Philadelphia, Pa., assignor to John A. Brill, same place.....	513,226
Car brake. George M. Brill, Philadelphia, Pa.....	513,229
Track sweeper for railways. George M. Brill, Philadelphia, Pa.....	513,230
Grip for cable cars. William H. Russell, Vancouver, Canada.....	513,283
Car brake. George F. Brandau, Cohoes, N. Y.....	513,298
Electric motor for street cars. Benjamin G. Lamme, Pittsburg, Pa., assignor to the Westinghouse Electric & Manufacturing Company, same place.....	513,401
Span wire for overhead electric railways. Sidney H. Short, Cleveland, O., assignor to the Short Electric Railway Co., same place.....	513,426
Safety brake. Kitchell A. Maynard, Kansas City, Mo., assignor of one-half to William M. Randall and George M. Randall, same place.....	513,432
Supply system of electric railways. Henry S. Pruyn, Hoosick Falls, N. Y., assignor to James S. Gibbs, Chicago, Ill.....	513,440

ISSUED JANUARY 30, 1894.

Trolley wire finder. Edward Gale, Peoria, Ill.....	513,566
Starter and propeller for electric cars. Ernest Schmitz and James Mendenhall, Chicago, Ill.....	513,598
Gearing for electric locomotive. George W. Schwartz, Florence, Ala.....	513,599
Car brake. Herbert E. Collett, Chelsea, Mich., assignor of three-fourths to Herbert E. Collett, Jr., Lynn, Mass., and Charles W. Armstrong and James Howard Bing, Philadelphia, Pa.....	513,670
Car brake. Willard Curtis, Grand Rapids, Mich., assignor to William T. Powers and William H. Powers, same place.....	513,672
Wheel fender or guard for cars. George Blakistone, Baltimore, Md.....	513,701
Wheel fender for cars. George Blakistone, Baltimore, Md.....	513,702

Safety fender or trap. George Blakistone, Baltimore, Md.....	513,703
Electric connection for railway rails. Alfred Green, Rochester, N. Y., assignor one half to William Rosboro, same place.....	513,777
Car truck. John B. Smitham, Oil City, Pa.....	513,835
Trolley pole stand. Gustav Valley, Cleveland, O., assignor to the Steel Motor Company, same place.....	513,846
Trolley pole stand. Gustav Valley, Cleveland, O., assignor to the Steel Motor Company, same place.....	513,847
Switch operating device. Handley P. Cogswell, Brooklyn, N. Y.....	513,883
Street railway brush. Philip A. Coonradt and Arthur Coonradt, Rockford, Ill.....	513,888
Sectional electric railway. George W. Demmick, Lynn, Mass., assignor one-half to Henry Robinson, George Fuller, John S. Earl and Knott P. Martin, same place.....	513,894
Power transmitting mechanism for electric locomotives. Mark W. Dewey, Syracuse, N. Y., assignor to the Dewey Corporation, same place.....	513,895

ISSUED FEBRUARY 6, 1894.

Load governor for electric currents. Frank E. Pritchard, Oswego, N. Y.....	513,930
Conduit electric railway. Rufus C. Beardsley, La Fayette, Ind.....	514,056
Electric car truck. Charles F. Winkler, Kingston, N. Y.....	514,109
Closed conduit electric railway. Frank M. Ashley, Hawthorne, N. J.....	514,112
Electric railway. Frank M. Ashley, Hawthorne, N. J.....	514,113
Electric railway conduit. Frank M. Ashley, Hawthorne, N. J.....	514,114
Electric railway. Oscar A. Enholm, New York, N. Y., assignor to Edward C. Reiss and John J. Ashley, Brooklyn, N. Y., and Frank M. Ashley, Hawthorne, N. J.....	514,120
Safety guard for street cars. George T. Foster, Rochester, N. Y.....	514,121
Underground electric conductor. Henry A. Seymour, Washington, D. C., assignor to the Short Electric Railway Company, of Cleveland, O.....	514,133
Closed conduit for electric railways. Henry A. Seymour, Washington, D. C., assignor to the Short Electric Railway Company, Cleveland, O.....	514,134
Motor controlling device for electric locomotives. Sidney H. Short, Cleveland, O., assignor to the Short Electric Railway Company, same place.....	514,135
Safety car fender. George Latz, Baltimore, Md.....	514,234
Electric trolley wheel shield. Henry S. Pruyn, Hoosick Falls, N. Y.....	514,274
Series electric railway. Michel A. Cattori, Rome, Italy.....	514,303
Trolley wire shield. Louis Eschner, Philadelphia, Pa.....	514,353
Cable grip. John A. Tauberschmidt, Washington, D. C.....	514,389

### GEORGE E. PRATT.

One of the best known men in both the steam and street railway fields is George E. Pratt, who February 12, resigned the general sales agency of the Lamokin Car Manufacturing Company, to take a similar position with the Jackson & Sharp Company, of Delaware. Mr. Pratt has crowded into his existence of thirty-eight years a wide and varied experience in many departments of steam and street railway work. He began by serving an apprenticeship in the Taunton Locomotive Works, but later perfected himself to enter the navy as engineer. This course being precluded by the death of an influential friend, he became a clerk for G. E. Bryden, Superintendent of the M. P. & M., N. Y. & N. E. R. R., at Boston, in 1879. In 1882 he accepted a like position elsewhere. Next Mr. Pratt was



GEO. E. PRATT.

one of the chief movers in the organization of the New England Railroad Club, and was its first Secretary. Still continuing in railroad work he became successively private secretary to the master mechanic of the N. Y. W. S. & B. R. R. and to the owner of the Chautauqua Lake Railway. Next he went to Tennessee to make a report on the Chesapeake and Nashville Railway, for Cincinnati and New York capitalists, declining a position on this road to become traveling mechanical inspector for the Pullman Company. This position he left to become general sales agent for Lamokin cars. Besides these qualifications, Mr. Pratt is a practical mechanic, an expert stenographer and a hand-in-glove associate of the Master Car Builders Association members and American Street Railway Association men. His wide acquaintance in both fields wish him the success he deserves.

### THE AMES REGISTER.

With the purpose of supplying to the street railway manager a fare register that may have all the commendable features of a portable register, a bell punch and a stationary register, furnishing the conductor with a complete record of his day's work, no matter how many times he changes car, the Ames Register Company, 53 State Street, Boston, has placed on the market the register herewith illustrated and described, and which is a radical departure from the present methods. The simplicity of the machine is self evident. The scheme is that of a stationary register containing a portable register. This portable register fits all stationary parts and is inter-

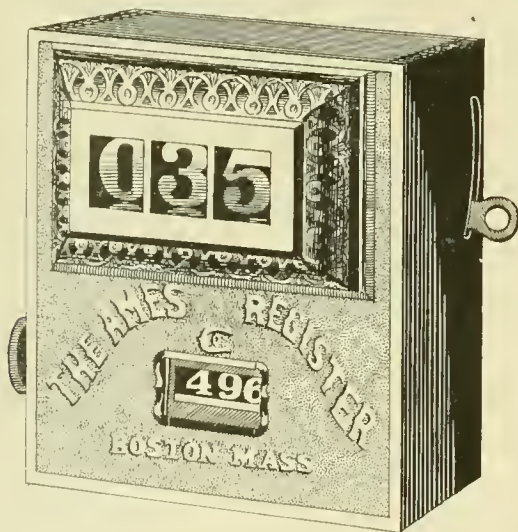

FIG. 1.

changeable. The stationary register can not be operated unless the portable register is in place, but the conductor may if desired by the company turn the stationary register back to zero at trip termini, without removing the portable register or altering its figures. The portable register numbers continuously to a million and starts at zero. Thus two distinct reports are given both unalterable. The engravings shown give a good idea of the plan; Figure 1, shows the register ready for operation; Figure

2, shows the portable register partly in place in the stationary; Figure 3, is the portable register. The method of manipulating the portable portion of this register is as follows: At the beginning of the conductor's day's work, he is furnished with the portable register, which he inserts into the stationary, or car register. Before oper-



FIG. 3.

ating the register he records upon his day-card the figures that appear on the portable register. At the close of his day's work, he turns in the portable register with his money and day-card. In computing the conductor's work, the official simply refers to the portable register to ascertain the number of fares taken during the day. By the use of this register it is unnecessary to assign an employe to the duty of recording the state of the register either before the register starts on its day's work or after

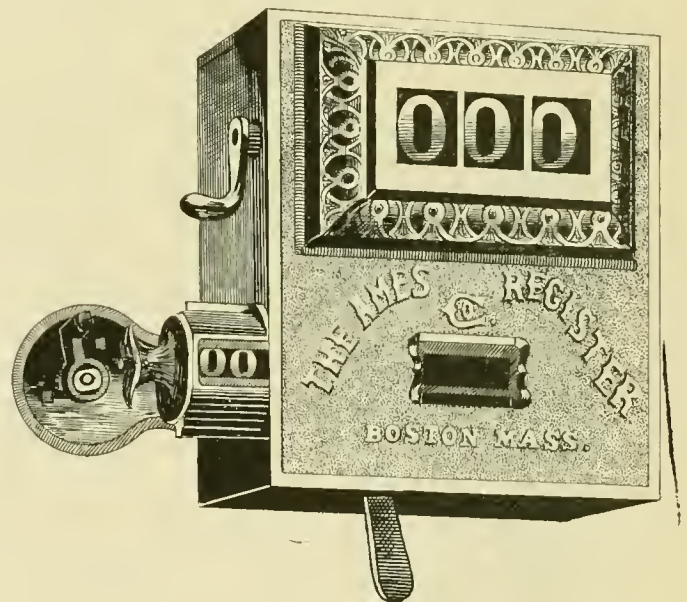

FIG. 2.

wards, the portable register doing this work. Every detail of the register is of the best workmanship and material, it is simple, durable and operated by one lever and the mechanism is accessible to the proper authority only. Louis Pfingst, the manager, will gladly furnish further details,

LANSING'S street railway during the month of January sold, at certain places, "Aid Society Tickets," one-fifth of the receipts of their sale going to the Aid Society of Lansing. Secretary Jay P. Lee is the immediate donor of the fund.

SIX sad and seedy stockholders went to the Keeley motor office, in Philadelphia, recently, and found no quorum, so they silently stole away.



## CAUGHT ON THE RUSH TRIP.

### American Street Railway Association.

HENRY C. PAYNE, PRESIDENT, Milwaukee, Wis.  
 WM. J. RICHARDSON, SECRETARY AND TREASURER, Brooklyn, N. Y.  
 W. J. STEPHENSON, FIRST VICE-PRESIDENT, Washington, D. C.  
 J. R. CHAPMAN, SECOND VICE-PRESIDENT, Grand Rapids, Mich.  
 LEWIS PERRINE, THIRD VICE-PRESIDENT, Trenton, N. J.  
 EXECUTIVE COMMITTEE: D. F. LONGSTREET, Denver, Col.; T. H. McLEAN, Indianapolis, Ind.; ED. WHITTAKER, W. Y. SOPER, Ottawa, Ont.; and E. S. GOOD, Rich, Hartford, Conn.  
 Place of next meeting, Atlanta, Georgia, third Wednesday in October, 1894.

### Massachusetts Street Railway Association.

President, J. H. CUNNINGHAM, Boston; First Vice-president, AMOS F. BREED, Lynn; Second Vice-president, FRANK S. STEVENS, Fall River; Third Vice-president, SAMUEL WINSLOW, Worcester; Secretary and Treasurer, A. E. BUTLER, Lawrence, Executive Committee, A. A. GLASIER, Boston; E. C. FOSTER, Lynn; CHAS. ODELL, Salem; P. F. SULLIVAN, Lowell; E. P. SHAW, Newburyport; PRENTISS CUMMINGS, Boston; R. S. GOFF, Fall River.  
 Regular meetings first Thursday of each month.

### Maine Street Railway Association.

President, WILLIAM R. WOOD, Portland.  
 Secretary and Treasurer, E. A. NEWMAN, Portland.  
 Next meeting will be held the first Wednesday in February, 1894.

### Ohio State Tramway Association.

President A. E. LANG, Toledo; Vice-president, W. J. KELLY, Columbus; Secretary and Treasurer, J. B. HANNA, Cleveland; Chairman Executive Committee, W. A. LYNCH, Canton, O.  
 Meets at Toledo on the fourth Wednesday in September, 1894.

### The Street Railway Association of the State of New Jersey.

President, JOHN H. BONN, Hoboken; Vice-president, THOS. C. BARR, Newark, Secretary and Treasurer, CHARLES Y. BAMFORD, Trenton; Executive Committee, OFFICERS and C. B. THURSTON, Jersey City; H. ROMAINE, Paterson; LEWIS PERRINE, JR., Trenton.

### The Street Railway Association of the State of New York.

D. B. HASBROUCK, PRESIDENT, New York City.  
 G. TRACY ROGERS, FIRST VICE-PRESIDENT, Binghamton.  
 JAS. H. MOFFATT, SECOND VICE-PRESIDENT, Syracuse.  
 WILLIAM J. RICHARDSON, SECRETARY AND TREASURER, Brooklyn.  
 The next meeting will be held at Syracuse, on the third Tuesday in September 1894.

### Pennsylvania Street Railway Association.

H. R. RHOADS, PRESIDENT, Williamsport.  
 B. L. JONES, FIRST VICE-PRESIDENT, Reading.  
 S. P. LIGHT, SECRETARY, Lebanon.  
 WM. H. LANIOUS, TREASURER, York.  
 Next meeting at Reading first Wednesday, in September, 1894.

### Texas Street Railway Association.

WM. H. SINCLAIR, PRESIDENT, Galveston.  
 S. A. HOBSON, SECRETARY AND TREASURER, Waco.  
 J. K. URIE, VICE-PRESIDENT, Austin.  
 Next meeting, third Wednesday in January, 1895.

### Arkansas.

LITTLE ROCK, ARK.—W. G. Brown, manager of the Arkansas Electric Supply Company, has received contract for a new plant at Searcy Ark., and will be in the market for a 750 light alternator with transformers and incandescent street light fixtures, also a 75-horse-power high speed engine.

### California.

POMONA, CAL.—C. W. Foote, the Cleveland capitalist, who is backing the street railway scheme, has taken up residence here.

ONTARIO, CAL.—The Ontario & San Antonio Heights Railway Company would like full information of any gas motor adapted to street railway purposes

OAKLAND, CAL.—The Consolidated Street Railway Company elects F. M. Smith, president; J. W. Coleman, vice-president, and A. K. Grim, secretary and superintendent.

OAKLAND, CAL.—Oakland Railroad Company files its incorporation at \$2,500,000. Directors: Charles F. Crocker, H. E. Huntington, S. F. Gage, C. E. Greer, F. S. Douty.

OAKLAND, CAL.—Borax King F. M. Smith is still bent on completing his proposed lines. A citizens' committee is conferring with Mr. Smith. The last project is to build eight miles of new line.

SAN FRANCISCO, CAL.—Geo. G. Buckland asks extensive franchises for electric railway lines, including many miles of street. He asks but 30 days to begin work, and six months to spend \$500,000, and three years to complete all work.

SANTA ANA, CAL.—The annual meeting of the Santa Ana, Orange & Tustin Street Railway elects the following officers: M. J. Bundy, president; N. Palmer, vice-president; Miss Mamie Ross-Lewin, secretary; Commercial Bank, treasurer.

OAKLAND, CAL.—Receiver Ira Bishop, of the Piedmont Consolidated, says that the receipts for November were \$6,417, and disbursements, \$10,947, or a net loss of \$4,530. December loss about \$3,000.

OAKLAND, CAL.—The receiver of the Piedmont Cable Company has been granted his application to mortgage the road, to raise \$15,000 to pay operating expenses until a purchaser may be found. It is also rumored that a change to electricity is contemplated.

SAN FRANCISCO, CAL.—The Underground Sealed Conduit Railway Company has incorporated, with \$500,000 capital and \$250 subscribed to sell letters patent for street car appliances. Directors, L. C. Pressley, L. G. Crossley, E. O. Rollins, L. L. Lindsay and C. S. Wheaton.

SACRAMENTO, CAL.—The Sacramento Power & Electric Light Company, Albert Gallatin, president, and Joshua Barker, secretary, has negotiated a loan of \$1,500,000, mortgaging all property and franchises to the California Safe Deposit & Trust Company for thirty years to secure the loan.

### Canada

WINDSOR, CANADA.—The Windsor Electric Railway will extend east, and are now after franchise.

TORONTO, CAN.—The Toronto Street Railway Company asks bids on its 6,000-horse-power station, about to be built.

LONDON, CANADA.—The London Street Railway Company elect H. A. Everett, president; E. W. Moore, vice-president, and S. R. Break, secretary-treasurer and general manager. The annual report shows gross earnings of \$52,244, and operating expenses of \$40,686, leaving revenue of \$11,557, an increase of \$4,175 over 1892.

HAMILTON, ONT.—The Hamilton Beach & Electric Railway Company is seeking incorporation. The capital stock of the company will be \$48,000, divided into 480 shares of \$100 each. The following are the incorporators: Messrs. John Calder, J. N. Waddell, A. E. Carpenter, Robert Campell, of this city; W. Kearns, M. L. A., Richard Baxter and W. Allen, Burlington.

### Chicago.

CHICAGO.—Lake street L will build electric plant at 1137 West Lake street, to cost \$7,000.

CHICAGO.—A subscriber wishes to know the address of the American Construction Company, and whether it has a Chicago office. Does any one know?

CHICAGO.—All persons having claims against the Railway Equipment Company are notified to present such, properly attested, to Geo. O. Fairbanks, receiver, at 305 Ashland block, Chicago, within three months.

CHICAGO.—South Side Extension Railroad Company, organized by Marcellus Hopkins, W. R. Champlin, Edwin L. Lobdell, W. W. Gurley, of Chicago, and David R. Lewis, of Evanston, proposes to build a loop for the Alley L. Capital \$1,000,000.

CHICAGO.—The Pollasky Elevated Railway for the North Side is incorporated by, L. O. Goddard, W. W. Tracy, Springfield; Fred C. Gardner, Gen. W. Sooy-Smith, James T. Hull and Andrew McNally, of Chicago, Green, Willits & Robbins, Home Insurance Building, are their solicitors.

CHICAGO.—Mysenburg & Wright are championing the advantages of the Siemens-Halske underground conduit system for Indiana avenue. The Love Electric Traction Company is also trying to persuade the use of their conduit, but the failure of the present Love line on Fullerton avenue militates against it.

CHICAGO.—The report that J. B. Wallace, of Ansonia, Conn., is about to form a new company for the electrical and railway supply business has been confirmed by Mr. Wallace. The incorporation papers have been issued. The old Ansonia Supply Company will be the basis of operations. Mr. Wallace is in Chicago.

CHICAGO.—The West Chicago Street Railroad Company now owns the Cicero & Proviso Electric Railway. Secretary Ballard, of the Cicero & Proviso, will not deny the truth of the statement, and advised the reporter to see E. A. Cummings, who engineered the deal. Mr. Parsons evaded a denial. There is no doubt but that the report is true, but no particulars are yet given out.

### Colorado.

PUEBLO, COL.—The Pueblo Street Railway Company asks right to extend to Bessemer, and loop. Will be granted.

DENVER, COL.—A. U. Buell, president, Capt. E. P. Miller, general manager, and directors of the Denver, Longmont & Noland Stone & Railway Company, have negotiations pending for the equipment of their road. Work to begin with spring.

### Connecticut.

NORWALK, CONN.—Norwalk Horse Railroad will change to electric traction.

HARTFORD, CONN.—The East Hartford & Glastonbury Horse Railroad, elects, president, E. S. Goodrich, Hartford; secretary, Geo. D. Curtis, Hartford.

BRIDGEPORT, CONN.—The street railway strike has been settled by a compromise. The two heaviest stockholders says that the contemplated change to electricity will come soon and cost \$500,000.

HARTFORD, CONN.—A large scheme, based on the several charters for street railways branching north from Hartford, is being unfolded. It contemplates the syndicating of all the city, suburban and interurban lines. William H. Goodrich is a prime mover in the affair. The General Construction Company, of Boston, has the contract for building lines from West Hartford to Farmington.

### District of Columbia.

WASHINGTON, D. C.—General Manager W. Kesley Schoepf, of the Eckington & Soldiers' Home Railway Company, asks for two permits, additional track laying.

GEORGETOWN, D. C.—The Georgetown & Tennallytown Electric Railway has made M. W. Offutt, president; H. Bradley Davidson, vice-president; John E. Beall, secretary and treasurer.

### Florida.

JACKSONVILLE, FLA.—It is understood that the Jacksonville Street Railway is to put in heavier rail and extend its system in Fairfield.

OPELIKA, FLA.—Auburn, Ala., and Opelika will be connected with a street railway. Capt. John L. Cowan, of Opelika, is the promoter, and \$30,000 of 6 per cent bonds have been sold. The line will be seven miles long.

### Georgia.

ROME, GA.—The court has declared the Rome Electric Railway solvent, and dismissed the application for receivership.

ATLANTA, GA.—Judge Pardee refuses the receivership asked by bondholders of the Atlanta Consolidated. President Hurt says that the matter of interest will be arranged soon, and that all will be satisfied with the arrangement.

### Illinois.

OAK PARK, ILL.—Oak Park Town Board grants Cicero & Proviso Electric Railway right to lay extension in town. Must be built within a year.

FREEMONT, ILL.—C. E. Loss & Co., of Chicago, will build the electric railway system in Freemont, changing the horse car line. Residents take \$25,000 stock. The plant will cost \$100,000.

MOLINE, ILL.—The People's Power Company has purchased the gas and electric plants of Moline and Rock Island, owned by the Brush Electric Company, for \$200,000. The Rock Island plant will be moved to Moline, to take advantage of the water-power.

EAST ST. LOUIS, ILL.—Organized, the Mark Equipment Company, at East St. Louis; railway equipments and supplies; capital stock, \$10,000; incorporators, F. S. Taggart, Henry L. Bauer, and Frank E. Nulsen. The company is the reorganization of the Mark Railway Equipment Company, of Cleveland, which failed six months ago.

### Indiana.

INDIANAPOLIS, IND.—The contract for the new power house on West Washington street has been let to Jungclaus & Schumacher. It will be 320 by 330 feet and cost \$125,000.

NEW ALBANY, IND.—The directors of the Highland Electric Railway Company, of New Albany, have elected J. F. Gehhart, president, and Col. W. W. Tuley, secretary and treasurer.

FT. WAYNE, IND.—The Lakeside Street Railway is bonded for \$100,000, to secure payment of bonds issued to the Knickerbocker Trust Company, of New York. R. T. McDonald is owner.

RICHMOND, IND.—Union Trust Company, of St. Louis, asks judgment on bonds of the Street Railway Company for \$212,000, and that Superintendent A. D. Titsworth be appointed receiver. The company is owned by Col. J. F. Miller and Russell B. Harrison. The line will continue operation. Hard times and decreased business the cause alleged.

### Iowa.

BURLINGTON, IA.—George O. Ray expects to break ground for his new street railway line early in the spring.

FAIRFIELD, IA.—The old Park & Belt Motor Line is to be rehabilitated and extended. The plan is not yet fully formed.

STOUC CITY, IA.—The bondholders of the Sioux City Street Railway Company, holding \$525,000 in bonds, have organized to buy in the road at the receiver's sale.

CLINTON, IOWA.—Superintendent Highlands, of the State Electric Company, is making arrangements for equipment of the North Second street electric light plant as a railway power station.

INDEPENDENCE, IOWA.—The company now controlling the Street Railway Company is officered as follows: R. Campbell, president; M. A. Campbell, secretary; A. D. Gurnsey, superintendent.

COUNCIL BLUFFS, IA.—A. K. Stone resigns superintendency of the Motor Company. J. T. Stewart is re-elected president; Chas. T. Stewart, secretary; J. H. Millard, treasurer. Mr. Stewart declined presidency and Guy C. Barton, of Omaha, was elected to fill place.

### Kansas.

LAWRENCE, KAN.—The Westinghouse Electric & Manufacturing Company is figuring on the electric equipment of the street railway line. J. D. Bowersock is authority for the statement that the line will pay, and that eastern capital is behind the scheme.

ATCHISON, KAN.—Atchison Telephone & Electric Light Company is organized by B. P. Waggoner, David Kelso and Ellsworth Ingalls, of Atchison, W. G. De Celle, St. Paul, and O. H. Simonds, Duluth, to put in a telephone, light and street railway system. Capital \$100,000.

## Kentucky.

LOUISVILLE, KY.—M. E. Eaken, of Louisville, wishes to buy five miles of about 30-pound second-hand steel T rail with splices for logging road, to be delivered at Cairo or Memphis, Tenn.

LOUISVILLE, KY.—The New Albany (Ind.) Street Railway Company, the Belt & Terminal Railway, and the New Albany & Portland Ferry, it is said, will go into receiver's hands, on application of Bennett H. Young, representing holders of first mortgage bonds.

## Maine.

ROCKLAND, ME.—The Rockland, Thomaston & Camden Street Railway Company elects, Hon. George E. Macomber, of Augusta, president; Hon. A. D. Bud, of Rockland, treasurer, and Hon. H. M. Heath, of Augusta, clerk.

## Maryland.

BALTIMORE, MD.—A bill is before the legislature to incorporate the Baltimore & Ann Arundel Electric Railway Company, at \$50,000 capital.

BEL AIR, MD.—The Deer Creek Electric Railway Company elects: F. W. Baker, president, and Noble L. Mitchell, secretary and treasurer, for the ensuing year.

HAGERSTOWN, MD.—The city council grants a franchise to O. H. Ormsby, of Pittsburg, and S. Ritter Ickes, of Altoona, Pa., for an electric railway. Thirty days given for acceptance.

BALTIMORE, MD.—P. A. B. Widener, of Philadelphia, is here in the interests of the Baltimore & Washington interurban.

A scheme is on foot and charter prepared for the consolidation of all the city railways, at a capital stock of \$12,000,000. All roads to be represented by directors in the new company.

BALTIMORE, MD.—To trolley the Chesapeake & Ohio canal, a company is organized by Chas. K. Lord, third vice-president of the B. & O.; Lloyd Lowndes, H. Crawford Black, Alexander Shaw and Clarence Lane.

Baltimore Traction Company lets contract for two lines, to J. G. White & Co., of New York.

## Massachusetts.

PALMER, MASS.—The Palmer & Monson Electric Company forms a new company, to build a street railway in Warren, West Warren, and West Brimfield. The new company is to be called the Central Massachusetts Electric Company.

LYNN, MASS.—Professor Elihu Thomson, of the General Electric, is reported to be about to withdraw from the company. His friends say that an attempt will now be made by Mr. Thomson and his associates to secure the big West Lynn plant for the new company, and there make new appliances and old ones not owned by the General.

SPRINGFIELD, MASS.—The Wyman-Lea Electric Railway Company is about to organize, to build a trunk line from Holyoke to this place. Miss Aldworth, a wealthy spinster of Holyoke, and Judge Wyman, of Boston, are interested.

The Central Massachusetts Electric Railway Company, which has been formed at Palmer, it is understood, proposes to connect all the towns on the Boston & Albany, by building a line between Springfield and Worcester.

BOSTON, MASS.—In the U. S. Circuit Court interested parties of the Interstate Railway, of Rhode Island, ask for a receiver for the Attleboro North Attleboro & Wrentham Street Railway Company, January 20, Cornelius Sweetland was made receiver for both roads. Now a separate receiver is asked for the the A., N. A. & W.

The Wyman-Lea Electric Railway scheme elects officers as follows: Henry S. Dickinson, of Springfield, as president; A. L. Green, of Holyoke, clerk; and C. Fayette Smith, of Holyoke, treasurer. The directors are Judge W. B. C. Pearsons, of Holyoke, ex-mayor George S. Taylor, of Chicopee, George Nye and H. S. Dickinson, of this city, Isaac C. Wyman, of Salem, Horatio Gore, of Boston, and B. W. Woodward, of Cambridge.

## Michigan.

BATTLE CREEK, MICH.—Bond holders of the street railway expect to have road sold by April 1. They will then rebuild at expense of \$50,000.

ST. JOSEPH, MICH.—C. P. Wright, of the St. Joseph & Lake Shore Electric Railway, says that the company means business, and that the Erie Steel Works has the contract for construction.

ST. JOSEPH, MICH.—St. Joseph & Lake Shore Electric Railway Company is organized at \$75,000, to build an electric railway in St. Joseph, Mich. The officers are C. P. Wright, president; J. S. Wolfe, vice-president; A. I. Thatcher, treasurer, all of Chicago, and S. C. Rosenberg, secretary, St. Joseph.

DETROIT, MICH.—Judge Taft has decided against the street railway company's claim that the city was stopped from proceeding against the company on account of having recognized the validity of an amended franchise giving it life until 1909. This is a victory for the city and involves all the railway company's franchises. The company is given three months to remove its tracks or get a new franchise. Case will be reviewed by the court of appeals.

## Minnesota.

MINNEAPOLIS, MINN.—Thomas Lowry has returned to Minneapolis, after a long eastern trip.

MINNEAPOLIS, MINN.—M. B. Ridgeway, of this city, is promoting an electric line from here to Lake Superior, with power houses every fifteen miles. To be used for freight.

MANKATO, MINN.—Henry W. Brown, city recorder, Mankato, will receive bids until March 1, for the lighting of the city electrically for a period of ten years, on the basis of 100 maximum and 50 minimum arc lights and 100 maximum and 50 minimum incandescent lights.

## Mississippi.

LAUREL, MISS.—Eastman, Gardner & Co., are in the market for a second hand lathe, of about four feet swing, and from six to ten feet between centers.

## Missouri.

HANNIBAL, MO.—The Stillwell Meat Company is preparing to put in a 300-light incandescent plant.

ST. LOUIS, MO.—The Bridge & Beach Manufacturing Company will erect new shop and buy 200-horse-power engine.

KANSAS CITY, MO.—The West Side Electric Railway elects W. N. Colar, Jr., president, and C. F. Hutchings, secretary.

KANSAS CITY, MO.—George Law petitions county court for right to construct an electric railway from Westport to Kansas City. Work to begin in six months.

KANSAS CITY, MO.—The Merriam Park, Rosedale & Kansas City Electric Railway, organized by C. W. Brown of Kansas City, and B. F. Hollenbeck of Shawnee, at \$50,000.

CARTHAGE, MO.—E. S. Rowse, of the St. Louis Trust Company, St. Louis, which owns the Carthage Horse Road, is investigating affairs of the line, with an eye to an electric change.

ST. LOUIS, MO.—Directors of the St. Louis & East St. Louis Electric Railway Company, are: C. C. Carroll, John N. B. Bollinger, D. R. Powell, V. W. Fisher and John J. Taussig.

CLAYTON, MO.—Organized: The Clayton & Creve Cœur Railroad, to build from Clayton, to intersect the Missouri Pacific, by Henry Chomeau, Phil Deuser, W. B. Glensfelder, H. M. Smith and Jacob Studt.

ST. LOUIS, MO.—The Clayton & Forest Park Electric Railway elects: president, Thomas K. Skinker; vice-president, John S. Bowland; secretary and treasurer, B. F. Thomas. Mr. Thomas stated that the company is in excellent financial condition, and that the road, which is now completed to Clayton, so far as the tracks are concerned, would be in operation by May 1.

ST. LOUIS, MO.—The following roads elect officers, as follows:

St. Louis & Suburban Railway Company—President, Charles H. Turner; vice-president, Samuel M. Kennard; secretary and treasurer, R. Lehman; directors, Clark H. Sampson, James Green, C. C. Maffitt, James Jackson and Ellis Wainwright.

Jefferson Avenue Street Railway—President, George A. Madill, to succeed P. C. Maffitt; directors, Edwards Whitaker, Robert McCulloch and P. C. Maffitt.

### Nebraska.

BEATRICE, NEB.—D. W. Morrow, Omaha, is elected president of the Rapid Transit Company; vice-president, Nathan Blakely; secretary and treasurer, L. E. Walker.

NEBRASKA CITY, NEB.—The Nebraska City Street Railway elects: President, H. H. Bartling; vice president, John J. Teten; treasurer, F. W. Rodenbrock; secretary, John C. Watson.

OMAHA, NEB.—W. S. Dimmick, of the Postal Telegraph Company, has taken the superintendency of the Omaha & Council Bluffs Street Railway & Bridge Company. He will move to Council Bluffs.

OMAHA, NEB.—The East Omaha Street Railway Company elects officers: Arthur S. Potter, president; Dudley Smith, vice-president; H. W. Yates, treasurer; Alfred B. De Long, V. O. Strickler, general attorney.

### New Hampshire.

DOVER, N. H.—William F. Brewster has been appointed receiver for the Consolidated Light & Power Company, and has taken possession.

### New Jersey.

BRIDGETON, N. J.—Business men petition the city council for franchise for the Bridgeton, Cedarville & Port Norris Electric Railway.

CAMDEN, N. J.—The extension of the Camden, Gloucester & Woodbury Electric Railway to Paulsboro will be pushed and in operation next spring. Bridges to be built.

MOUNT HOLLY, N. J.—The Burlington County Electric Railway Company is organized at \$125,000 by Jacob F. Burrows, James L. Grieb and William M. Esler, of Philadelphia; Robert B. Esler, Jr., of Ardmore, and S. H. Morison, of Camden, N. J., to build freight and passenger line between Mount Holly and Burlington.

MT. HOLLY, N. J.—The Burlington County Electric Company has been organized, with a capital of \$125,000, and will operate an electric road between Mount Holly and Burlington. The incorporators are: Jacob F. Burrows, James L. Grieb, and William M. Esler, of Philadelphia; S. H. Morison, of Camden; and Robert B. Esler, Jr., of Ardmore, Pa.

TRENTON, N. J.—The Bristol & Trenton Passenger Railway has secured right for twenty-six miles of road to Morrisville. Several big bridges will be built. The officers of the road are as follows: President Col. Edward Morrell; vice-president and general manager, Henry V. Massey; secretary and treasurer, William V. Massey. These officers with Frank G. Edwards, of Bristol, and William G. Thompson, form the board of directors.

NEWARK, N. J.—The New Jersey Consolidated Traction Company has elected these officers: President, E. F. C. Young, of Jersey City; vice-president, Jeremiah O'Rourke, of Newark; general manager, David Young, of Newark; secretary, Thomas J. George, of Newark; treasurer, R. F. Bower, of Philadelphia; auditor, W. J. Ramsay, of Newark; chairman of the committee on construction, B. M. Shanley; superintendent of the Newark system, D. W. Sharpe; superintendent of the Jersey City system, Thomas Sayre; purchasing agent, Charles H. Thorne; roadmasters, A. W. Pratt, of Newark, and James W. Leahy, of Jersey City. The company intends to extend its trolley system across New Jersey.

### New Mexico.

ALBUQUERQUE, N. M.—Jesse M. Wheelock, for O. E. Cromwell, takes possession of the street railway, and appoints A. A. Trimble superintendent.

### New York.

NEW YORK CITY.—Edward E. Higgins is settled at 26 Cortlandt street, as "expert in street railway values and economics."

ALBION, N. Y.—The plan for an electric road from Batavia, Albion, and Oak Orchard is promoted by F. A. Sickles, of Buffalo.

BROOKLYN, N. Y.—The Brooklyn City Railway elects old board of directors, except A. J. Lyman, who is succeeded by S. L. Husted.

NEW YORK CITY.—Austin Corbin, of the Brooklyn L, reports favoring extension of the Long Island Railroad Company and of the L.

WILLIAMSVILLE, N. Y.—Directors of the Buffalo & Williamsville Electric Railway decide to order two open cars, to be delivered April 1.

WAVERLY, N. Y.—The Waverly, Sayre & Athens Electric Railway Company has bought a power house site. The road will operate May 1.

ELMIRA, N. Y.—The West Side Railway Company will increase its stock from \$100,000 to \$300,000. Money will be used for extensions and improvements.

BUFFALO, N. Y.—Manager H. H. Littell says that the street railway will acquire more power either from the Niagara Company or by building a new power plant of its own. East Side power house to be built next spring.

NEW YORK CITY.—Charles A. Johnson, formerly of Johnson, Kelley & Miller, will confine his attention to street railway securities, and have offices at 80 Broadway. He is largely interested in street railways in New Jersey, and a fully competent judge.

POUGHKEEPSIE, N. Y.—Joseph Morsehauser, of this city, is appointed receiver for B. Van Steenburg, the promotor of the Highlands & New Palatz Electric Railway, which has a bonded debt of \$145,000 and issue of stock of \$40,000 but which was never built.

NEW YORK CITY.—William Caldwell, Chas. A. Stadler, John C. De Le Vergne, William Shaw, John C. McNamara, Anthony N. Brady, Robert C. Pruyn, Edward A. Maher, and Thos. N. Oleott, are elected directors of the Union Electric Railway Company.

NEW YORK CITY.—W. A. H. Bogardus, late secretary of the Brooklyn City Railway Company, has been made general manager of the same, and Cyrus P. Smith will become secretary. Superintendent Cameron will oversee the Central and South Divisions and William Morrison will have the eastern lines.

WAVERLY, N. Y.—Waverly, Sayre & Athens Railway Company elects A. N. Broadhead, president; Dr. F. M. Stevens, vice-president; A. C. Wade, secretary and treasurer. The board of directors consists of: J. L. Hamilton and J. Tinsabaugh, of Sayre; S. D. Broadhead, of Jamestown, and William Christy, of Cleveland, Ohio. E. S. Chapman, is chief of construction.

NEW YORK CITY.—President D. F. Lewis, of the Brooklyn City, details the consolidation of the Broadway and associated lines of the Brooklyn City and the Long Island Traction Companies. The new system will be called the Brooklyn, Queens County & Suburban Railway and is capitalized at \$10,000,000. One hundred and six miles of rack are to be operated.

NEW YORK CITY.—A sweeping change of the directorate of the Dry Dock, East Broadway & Battery elects the following new men: George H. Prentiss, A. S. Rosenbium, Simon Danzig, Solomon Mehrbach, John H. Waydell, E. W. Sumner, Edward C. Hillier, Marshall S. Driggs, and M. Feuchtwanger. They will take the places of Messrs. William White, John H. Scribner, John E. Hoffmire, Charles A. Hotchkiss, Wm. Richardson, Joseph Jacobs, S. Sidney Smith, and Peter J. Thorne.

SYRACUSE, N. Y.—The organization of a big syndicate of the principal headlight manufacturers of the country has been formed here. It included makers of steam road and street railway headlights, and is capitalized at \$1,500,000, and comprehends St. Louis, Chicago, Dayton, O., Rochester, Syracuse, and Utica firms. No officers have yet been chosen, but a board of directors has been named, including Irwin A. Williams, Utica; Pomeroy L. Salmon, Syracuse; Frank S. Upton, Rochester; Ward W. Willits, Chicago; John Kirby, Jr., Dayton, O., and Alexander Handlan, St. Louis.

NEW YORK CITY.—Henry R. Worthington makes a motion for the appointment of a receiver, before Judge Barrett, for the Thomson-Houston Electric Company, of New York. Mr. Worthington is judgment creditor for \$1,576. There is also a judgment against the company for \$75,279, in favor of the Durant Land Improvement Company, for rent. Geo. W. Mastin, president of the company, recites that the company's property is worth \$300,000, and that the liabilities are \$738,000. Decision reserved. Mr. Sunny says that the company is a local affair, and does not affect the General Electric.

## North Carolina.

NEW BERNE, N. C.—R. P. Williams, of the New Berne Electric Railway, has returned from the north, announcing that storage batteries will be used.

## Ohio.

CINCINNATI, O.—The Cincinnati Street Railway Company will adopt an air brake.

LIMA, O.—A. E. Townsend, of Pittsburg, has been here to arrange Wayne avenue extension of the electric railway.

WARREN, O.—The Trumbull road re-elects old officers and will decide February 20 on extensions and improvements.

WARREN, O.—E. J. Ohl and W. W. Rosensteel are appointed receivers for the Niles & Mineral Ridge Electric Railway.

CLEVELAND, O.—The Cleveland & Berea Street Railway Company is to be equipped with the trolley instead of storage batteries.

OBERLIN, O.—Daniel Freeze and G. M. Parker are leaders in a scheme for an electric railway between here and North Amherst.

WARREN, O.—Mineral Ridge & Niles Electric Railway has been appraised at \$56,430 and will continue operations under receivers.

CLEVELAND, O.—President H. E. Andrews has decided to greatly improve his entire system and to buy new rolling stock and supplies.

COLUMBUS, O.—The Indianola Fourth Street Railway Company is incorporated at \$10,000 by C. E. Miles, Robt. Thomson, M. E. Schaeffer et al.

CLEVELAND, O.—The Cleveland City Railway Company has made application for a franchise in the town of Glenville, for a term of twenty-one years.

CINCINNATI, O.—The Mt. Adams & Eden Park Street Railway Company re-elects John Kilgour, president, and Jas. A. Collins, secretary and treasurer.

POMEROY, O.—The scheme to electrify the belt railway and connect several towns is well on foot. It will cost \$300,000. The line is to be operated by June 1.

WARREN, O.—W. T. Williams, president of the Mineral Ridge & Niles Electric Railway, obtains judgment against the street railway for \$3,530, which will precipitate receivership.

CLEVELAND, O.—The Willson avenue barns of the Cleveland Electric Company burned, January 13, destroying eighteen motor and twelve trail cars. Loss is \$60,000. Incendiary origin is alleged.

TOLEDO, O.—J. K. Tillotson has obtained \$100,000 backing to begin construction and equipment of the Maumee electric road, and construction will begin as soon as \$20,000 is raised by subscription.

TIFFIN, O.—Tiffin Electric Street Railway elects officers, as follows: President, M. Frost; vice-president, Wm. H. Dore; secretary, N. W. Miller; treasurer, R. D. Sneath; general manager, Frank Bloom.

CLEVELAND, O.—The Buckeye Electric Company has gained the suit dissolving the injunction against manufacturing the Buckeye incandescent electric light. This gives it liberty to proceed with manufacture.

NORWALK, O.—President De Witt, of the Sandusky, Milan & Norwalk Electric Railway, and Manager Wood, of the same road, will be assisted by local capital in a new electric railway through the north part of the county.

YOUNGSTOWN, O.—The Youngstown Park Falls Electric Railway Company and the Youngstown Electric Railway have consolidated. Extension to Lanterman's Falls in the spring, and to Canfield will be made during the year.

CINCINNATI, O.—The Avondale car sheds and machine shops burn loss \$175,000. Thirty motor cars and forty-eight trailers destroyed. Defective wiring the probable cause. Insurance \$150,000. The Consolidated Street Railway Company is the loser.

TIFFIN, O.—All the Tiffin & Fostoria, the Tiffin Street Railway Company lines, the Tiffin Electric stock, have been transferred to the Tiffin Interurban Consolidated. Eastern capital has perfected the consolidation, and the connecting links will be built by May 1.

JACKSON, O.—City council has favorably acted on the Wellston & Belt Line proposition. The road is to connect McArthur Junction and Jackson, will build about forty miles, and use both steam and electricity. The directors are Harvey Wells, David Clatts, H. C. Wills et al.

COLUMBUS, O.—The Columbus Street Railway Company elects Emerson McMillin, president; E. K. Stewart, first vice-president; R. E. Sheldon, second vice-president; P. V. Burlington, secretary and auditor. The general superintendent and minor officers will remain unchanged.

DEFIANCE, O.—Geo. W. Bechel is appointed receiver for the Defiance Light & Power Company, on application of the Machine Works and the Standard Oil Company, large creditors. The enterprise includes gas, electric light and railway plants. Liabilities, \$30,000; plant worth, \$100,000.

CLEVELAND, O.—Cleveland City Railway Company (Little Consolidated) elects officers: President, M. A. Hanna; vice-president, F. De H. Robinson; secretary and treasurer, J. B. Hanna; general superintendent, George Mulhern. Report says, \$850,000 was expended between June 1 and January 1 for improvements.

CLEVELAND, O.—Horace E. Andrews succeeds Henry A. Everett as president of the Cleveland Electric Railway Company, being nominated by Mr. Everett. Mr. Everett is made vice-president; James Parmalee, president, and R. A. Harman, secretary; L. E. Beilstein, assistant secretary; Henry Beilstein, assistant secretary; Henry J. Davies, adjuster and secretary of the board of directors; Tom L. Johnson, chairman of the board of directors; Charles W. Wason, electrical engineer and purchasing agent; John J. Stanley, general superintendent.

## Oregon.

ALBANY, OREGON—The Albany Street Railway power-house and car barn, totally destroyed by fire.

## Pennsylvania.

COLUMBIA, PA.—President Given opens the Columbia & Donegal Street Railway.

MIDDLETOWN, PA.—The Middletown Electric Railway has had its franchise annulled by the city council.

MCKEESPORT, PA.—The Versailles Traction Company elects W. C. Soles, president, and A. B. Campbell, secretary and treasurer.

FRANKLIN, PA.—The Franklin Electric Railway Company elects A. H. McKelvey, president, and resolves to begin work in the spring.

PHILADELPHIA, PA.—J. A. Hanna has opened an Eastern office for the McGuire Manufacturing Company at 1050 Drexel building, Philadelphia.

JOHNSTOWN, PA.—President Moxham says that the Johnson Company will put \$3,000,000 into a new plant for manufacturing their recently patented products.

PITTSBURG, PA.—Braddock Electric Railway will extend to Edge-wood, A. L. Sailor is president and C. F. Ellis superintendent. The franchise is obtained in Braddock township.

PITTSBURG, PA.—J. C. Whitla, Beaver Falls, president of the Homestead Street Railway of this place, says that work will begin April: All capital is now ready and right-of-way secured.

WEST CHESTER, PA.—S. M. Patterson, president of the Pennsylvania Traction Company, officially announces that work will begin next spring on the new electric line from Harrisburg to Philadelphia.

PHILADELPHIA, PA.—People's Passenger Railway, the People's Traction and its leased lines, and the Philadelphia Traction have had their numerous requests for extensions referred to a special committee.

PHILADELPHIA, PA.—The People's Traction Company's order for 270 cars, is divided between Pullman, St. Louis Car Company and the Lamokin Car Company. The track equipment was divided between Brill and Peckham.

SLATINGTON, PA.—The Slatington Street Railway Company is organized. Capital, \$30,000. President, R. W. Mosteller, Slatington; directors, Henry Buttner, John W. Balliet, H. W. Hanker, Slatington; Morris Hoats, Allentown.

PHILADELPHIA, PA.—The Hestonville, Mantua & Fairmount Passenger Railway directory decides to put in electricity, and will issue \$500,000 in stock and \$750,000 in bonds. The stockholders will consider the matter March 12.

LANCASTER, PA.—A mortgage for \$2,000,000 has been filed against the Pennsylvania Traction Company, to secure 1,500 bonds, of \$1,000 each, and 1,000 bonds of \$500 each. The Provident Life & Trust Company, of Philadelphia, is named as trustee.

PHILADELPHIA, PA.—Joseph T. Skerritt, general manager of the Brigantine Traction Company, 144 South Fourth street, Philadelphia wants an alternating generator, new or second hand (later in good condition), for 750 or 1,000 lights. Send best figures and send them quick

READING, PA.—Application will be made to Governor Pattison, on February 8th, for a charter for the Metropolitan Electric Company, of this city. The incorporators are R. N. Carson, R. Nelson Buckley, and David C. Golden, of Philadelphia; John A. Rigg and Richmond L. Jones, of this city, and its object is to furnish power to the Reading Traction Company.

KITTANNING, PA.—The electric railway here to Ford City (five miles) is again being agitated. A New York company has secured the charter granted two years ago to A. C. Bailey and J. D. Bailey, of Ford City, Tyson Hellman and Fred Wick, of Kittanning, and others. C. A. Siegfried, of New York City, represents the capital, and says the road will operate next summer.

READING, PA.—Those interested in the Reading & Southwestern Electric have decided to proceed with construction and will apply for a charter for the first division, to be called the Mohrsville & Adamstown Electric Railway. The officers and directors are: President, Ludwig T. Custer; vice-president, Ex-Senator E. Billingsfelt, Adamstown; secretary and treasurer, George W. Keim, Reading; A. C. Snader, Ex-Senator Billingsfelt, S. Miller, Elmer E. Billingsfelt, H. C. Mohn, R. Hyman, Adamstown; Isaac Spatz, Mohrsville; Dr. J. B. Sterley, W. Van Reed, H. C. Geissler, V. S. Seltzer, Reading, and James W. Shepp.

### Tennessee.

KNOXVILLE, TENN.—The Middlebrook Electric Railway is about ready to operate. Prof. J. K. Payne is the engineer.

CHAFFANOOGA, TENN.—Mr. Gustafson, of Corinth, Miss., has been made superintendent of the Electric Railway Company, under President Adams.

CLARKSVILLE, TENN.—Clarksville Street Car Company elects officers; W. M. Daniel, president; F. P. Gracey, vice-president, and J. B. Polk, secretary. The car line is being extended to Porter's Bluff on Red river,

NASHVILLE, TENN.—The United Electric Railway Company now in receiver's hands, is to be reorganized by Gen. W. H. Jackson. The plan calls for \$140,000 improvements and repairs, and the taking up of \$1,500,000 old bonds in new bonds or cash, and to pay for other bonds in stock.

### Texas.

WEST (MCLEAN CO.), TEX.—West Power & Light Company organized at \$25,000 by W. W. Glasgow, W. W. Morgan, et al., all of Houston.

AUSTIN, TEX.—The Texas Street Railway Association held its first meeting January 24, and elected the following officers: W. H. Sinclair, Galveston, president; J. K. Urie, Austin, vice-president; S. A. Hobson, Waco, secretary-treasurer; and A. W. Childress, of Dallas, and W. H. Weis, of San Antonio, directors.

### Utah.

SALT LAKE CITY, UTAH.—The Salt Lake Rapid Transit Company elects: President, J. S. Cameron; secretary, Geo. S. Gannett; superintendent, A. M. Hinckley.

SALT LAKE CITY, UTAH.—The Cedar City Terminal Railway, of Cedar City, Iron county, is incorporated for \$20,000, by W. W. Cluff, Coalville, Elias Morris, and J. E. Langford, Salt Lake City, et al., to build ten miles of railway, to cost \$200,000.

### Virginia.

PORT NORFOLK, VA.—The Portsmouth & Port Norfolk Railway will change to electricity and add two miles of new track. Bonds are now to be marketed to make the improvements.

CHARLOTTEVILLE, VA.—The city grants the Piedmont Construction Company franchise on some of the principal streets for electric railway. They must begin construction in ninety days.

### West Virginia.

PARKERSBURG, W. VA.—The city attorney has been instructed "to prepare a franchise acceptable to the Park City Railroad."

### Wisconsin.

RHINELANDER, WIS.—Rhinelanders wants a street car line, and claims to be able to support it.

RACINE, WIS.—Amended articles of the incorporation of the Belle City Street Railway have been filed, increasing the capital stock to \$200,000 and allowing the selling of light and power from the trolley circuit.

MILWAUKEE, WIS.—A second mortgage for \$1,300,000 on the property of the Milwaukee Street Railway Company, has been filed in favor of the Central Trust Company, of New York, which holds the \$10,000,000 first mortgage.

The transfer of the Becker lines has been made to the Consolidated, and, formally, B. K. Miller, Jr., is made president; W. L. Mason, vice-president, and Geo. O. Wheatcroft, secretary and treasurer.

### Wyoming.

CHEYENNE, WYO.—It is the intention of the Street Railway Company to put in an electric equipment. The present track has been bought by Denver parties for mine railways, and will be moved.

## AS AN EDUCATIONAL ADJUNCT.

The progressive and accommodating street railway company, of Bath, Me., renders the accommodation to the school children of the city, suggested by the illustration. On stormy days the lower grades of the city schools hold

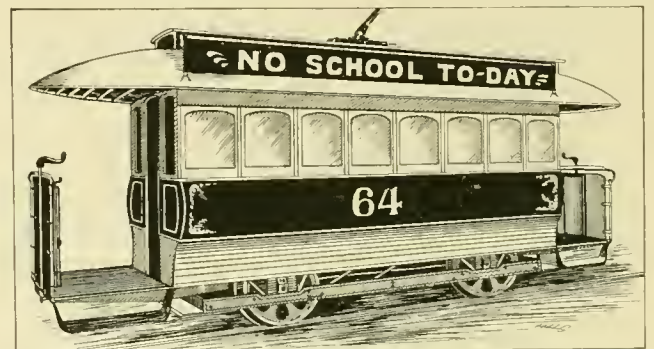

no session and the youngsters' parents are apprised of the fact by a placard attached to the street cars, bearing the legend, "NO SCHOOL TO-DAY;" or "ONE SESSION ONLY", as the case may be. Treasurer Twitchell, of the company, says the method is effective and a great accommodation to the children.

**A QUEER STRIKE.**



OF the queerest strikes on record occurred at Emporia, Kan., February 2, paralyzing the street railway system of Emporia. The strikers came to terms in two hours. The walking delegate in the case surreptitiously entered the mule stables of the company and loosened all the mules. "When the doors were opened the mules began to sing," and with caudal appendages erect made a break for liberty, braying like mad. It took several hours to capture their asinine majesties, when work was resumed.

**CHEAP POWER AT LITTLE ROCK.**

The power plant of the Little Rock Consolidated, which was designed in 1891, by B. J. Arnold, consulting engineer, 565 Rookery, Chicago, has just passed its second year of operation. The general manager, H. G. Fleming, says that the cost of power for 1893, including labor, was 1.05 cents per car mile, of which cost 0.7 cents was for fuel. Deducting the extra cost for the power produced and used for other purposes than the street railway, leaves the net cost of power 1.03 cents per car mile. As the number of the cars is but seventeen the figures are nothing less than remarkable. In 1892 the power cost was 1.39 cents per car mile and in 1894 Mr. Fleming has hopes of even a further reduction.

**THE SMITH TROLLEY HANGER.**

A very simple trolley clamp or hanger has been invented by C. H. Smith, superintendent of the Lebanon and Annville Street Railway. The wire is held in a sleeve made of a simple sheet of brass bent around the wire. The edges of this brass sleeve are inserted in a slit in the brass hanger casting and held by rivets put through holes in the casting. The brass sheet is formed

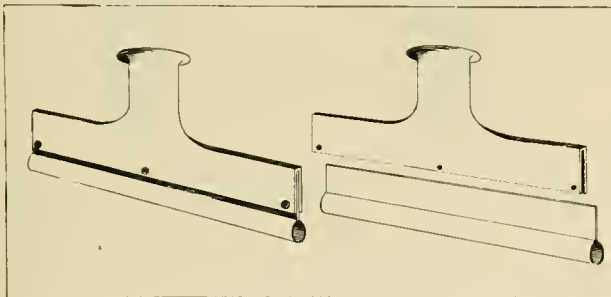

to a size a little smaller than the trolley wire before application so that there is a tight fit. The device has the advantage that the wire can never come entirely loose and fall to the ground, although it would seem that in time the wire might work slightly loose in the sheath. Some of these have been in use for three months on the Lebanon and Annville and Mr. Smith reports them to be in a satisfactory condition.

**MRS. LONGFIELD LOST.**

A damage suit against the Madison, Wis., City Railway Company, for \$5,000, brought by Mrs. Margaret Longfield, has resulted for the defendant. The trial occupied two days and it was proven that the woman became frightened on account of the car being turned back on a grade to avoid a collision. In her fright she jumped off the car carelessly, sustaining a few bruises, for which damage she sued. The judge charged the jury to find for the defendant. This was Manager Geo. H. Shaw's first damage suit and he is naturally very pleased at its outcome.

**GEORGE A. YUILLE.**

The newly elected secretary and treasurer of the West Chicago Street Railroad Company comes to his office well prepared for the many and difficult duties and complexities hidden under the simple title of secretary and treasurer.



G. A. YUILLE.

Secretary George A. Yuille was born of a well-known Southern family, thirty-two years ago, at Mobile, Ala., where he received his education and the preliminaries of his business training. Thirteen years ago, however, he came to Chicago as secretary of the Packing and Provision Company, in which position he remained six years. The next four years were spent as secretary and treasurer of the gas companies united in the trust, and two years more found him president of the Economic Natural Gas Company. It is with this fullness of experience in corporation affairs that Mr. Yuille takes the chair so eminently well filled by R. W. Crawford for the past seven years, and in which he will no doubt be as successful.

**STREET CAR REFORM.**

Reuben, Reuben, I've been thinking  
What a difference there'll be  
When the Council gets its thumb-screw  
On the street car company.

Cynthia, Cynthia, 'tis intended  
By the scheme that has been planned  
If one sits, he pays a nickel,  
But a cent, if he must stand.

Reuben, Reuben, more politeness  
This will teach you men I'm sure;  
He who gives seat to no lady  
Pays four cents to be a boor.

Cynthia, Cynthia, I am certain  
You like all the women are  
And you'll wait to get a bargain  
Riding on a crowded car.

Every one with one cent ready,  
Will wait long and grumble loud:  
"That last car was nearly empty!  
I am waiting for a crowd!"

A VISION FULFILLED.

The issue of the Scientific American for June 5, 1880, contained the illustration here represented, of "Edison's New Electrical Railway," built at Menlo Park. The description says:

"The motor is precisely like one of Mr. Edison's electrical generators and the power is supplied by his stationary engine, the power being converted into electrical

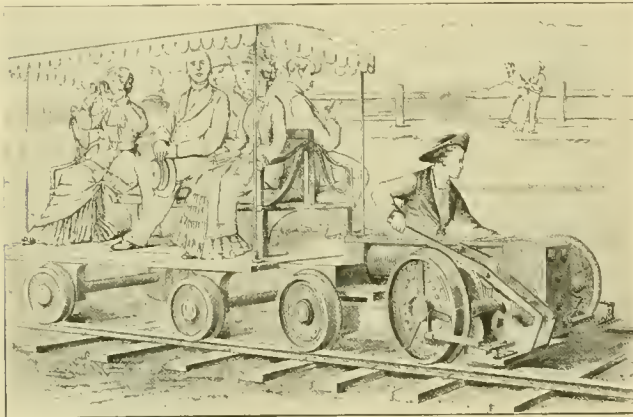

(From Scientific American, June 5, 1880.)

energy. \* \* \* The current thus created is conveyed to the track by two copper wires, one to each rail. \* \* \* The engine runs at the rate of twenty-five miles an hour. \* \* \* It is not entirely visionary to expect that our street railways and elevated railways may not at some very distant date be successfully operated by electricity."

This was but fourteen years ago, and how "visionary" the prophesy of the American was, we all know.

MR. RICHARDSON'S WILL.

The New York Sun says: "The will of the late William Richardson, of Brooklyn, who was long president of the Atlantic Avenue Railroad, has been admitted to probate. It bears date May 26th, 1887, and ex-Secretary Tracy is one of the witnesses. The entire real and personal estate, valued at \$165,980, is left to the widow, Mary Richardson during her life, and at her death, it is to be divided into five parts, two of which are to go to Louisa Richardson, the daughter, in case she remains unmarried, and the remaining three to the three sons of the testator Wm. J. Richardson, John E. Richardson, and Charles A. Richardson, in equal parts.

Should Miss Richardson marry before her mother's death, each of the four children is to receive an equal share. It was generally supposed that Mr. Richardson's estate amounted to \$1,000,000, at least."

A CALIFORNIA woman has been denied a suit for \$20,000, for damages to her health and business by reason of a street railway accident, for three good reasons: first, she was not injured; second, she had no business, and third, she lied about the whole affair.

LOS ANGELES DOGS WALK.

In Los Angeles there has been an order issued to conductors of the cable division of the Consolidated Company not to allow dogs on the cable cars unless 50 cents fare is paid for each of the canines. Dogs have never been allowed on the electric cars. The many people who have been annoyed by dogs on the cars, from the wooly window washer, beribboned poodle and panoplied pug to the big yellow cur, will be glad of the move to keep the dogs at home, where they belong.

A SAFETY CLUTCH BRAKE.

The Safety Clutch Brake Company, of 725 Sansom street, Philadelphia, makes the coupled clutch brake, of new design shown herewith. The brake is designed to be placed on the front timber of the car platform. The device is easily understood from the accompanying engravings. The scheme of action is as follows:

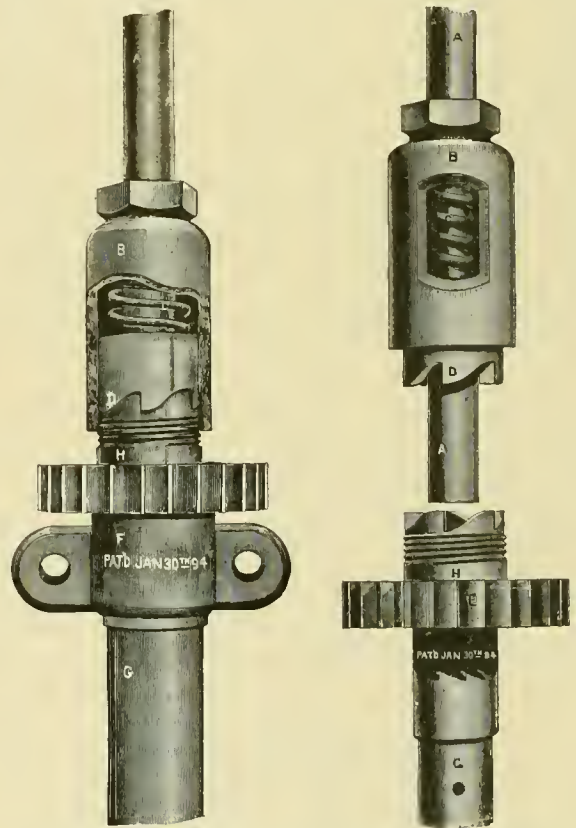

A—Brake shaft extending down through H; B—Casing enclosing C the spring which forces D, the upper clutch in position to form coupling; H—Lower clutch which forms the hub of sprocket wheel E; F—Box or bearing that is bolted to front timber of platform, securing E in rigid position; G—Brake chain shaft, lower end of which is supplied with suitable brace to prevent springing or bending.

The advantages claimed are; the extra direct thrusts of the five bearings give more power; it is stronger, with less parts and no screws; no welding to the staff. The total area of thrust bearings is 1/2 inches. It is strongly endorsed by the Philadelphia Traction, and Peoples' Railway Companies of Philadelphia.

The officers are, L. Bachheimer, president; C. E. Baird, vice-president and general manager; and E. M. Fields, secretary and treasurer.





THE CLEVELAND CONSTRUCTION COMPANY has moved its offices from Cleveland to No. 244 South Howard street, Akron, Ohio.

THE NILES TOOL WORKS, of Hamilton, are sending out a fine souvenir in the form of a cigar case, of one of which we are in receipt.

THE silver amber sheet mica of the Palermo Mica Company, 27 Peck Slip, New York City, is meeting with ready acceptance by the trade.

THE Delaware County & Philadelphia Electric Railway has ordered twenty-four cars of the Lamokin Car Company, to be mounted on McGuire trucks.

WM. HAZLETON, III., has taken the eastern agency of the Fulton Foundry Company, Cleveland, and has fine offices in the Havemeyer Building, New York.

IT is reported that E. P. Allis & Co., of Milwaukee, are about to enter the field of electrical manufacture, making dynamos to couple direct to the Allis engine.

THE Texas agency of the Ideal engines made by A. L. Ide & Son, of Springfield, Ill., has been surrendered by Fred A. Beall, of Fort Worth, to Hunter & Booso, of Dallas.

THE CHICAGO ELECTRIC TRUCK COMPANY, Chicago, came into corporate being January 29, at Springfield. It is capitalized at \$25,000, by C. W. Lyman, John Fraser and George H. Graham.

A VERY handsome steel engraving embellishes the large calendar sent out by the Pittsburg Steel Hollow Ware Company, and which will be mailed on request to street railway companies.

THE Belle City Railway Company, of Racine, Wis., has installed a McIntosh & Seymour engine of 225-horse-power. The company now has 750-horse-power and will furnish private lighting.

THE ELECTRIC TRACTION COMPANY of Philadelphia order 10 cars of Jackson & Sharp and 40 from Pullman. The General Electric got 40 motors and the Curtis Electric an order for 10 motors. Trucks are all McGuire.

THE Delaware County & Philadelphia Electric Railway has bought cushion car wheels for equipment of twenty-four cars, and the Electric Traction are also ordering several sets with a view to further purchase later.

THE SCHULTZ BELTING COMPANY, of St. Louis, has just received an order from England for 2,800 feet of belting and an order from Russia for 15,000. The belt trade is reported awakening and prospects for spring trade good.

A HANDSOMELY framed photograph of one of the Lewis & Fowler Manufacturing Company's fine cars has been placed on the wall of the REVIEW editorial room. It is the remembrance of George W. Myers, the secretary of the company.

HUGH McMILLAN, of Detroit, has entered upon the street railway specialty field. He will deal in rail bonds, overhead line equipment and similar goods. Mr. McMILLAN is well known and has the best wishes of the fraternity in his new venture.

CAR BODIES, on short notice, can be supplied by the Ellis Car Company as follows: 5 nine-bench open bodies with closed ends; 10 ten-bench of the same description; 5 sixteen-foot box bodies; 5 nineteen-foot box bodies, and 1 twenty-five-foot box.

A. GROETZINGER & SONS, 271 River avenue, Allegheny City, Pa., besides placing a goodly number of Dermaglutine pinions and gears, place on the editorial desk a neat paper weight and match scratcher, containing on the face a neat card for Dermaglutine.

PRESIDENT BALLARD, of the Lewis & Fowler Manufacturing Company, says his company is fast feeling the effect of improvement in business, their factory being well supplied with orders in every department, and also notice a marked improvement in collections.

HOWARD E. HITCHCOCK, formerly of Springfield, Mass. has accepted the city salesmanship of the Raymond gas engine for Chicago. F. M. Hicks & Co., of Chicago, make the engines, and are about to market a series of from three to twenty-five-horse power for street railway work.

THE order of 250 new cars by the People's Traction Company, Philadelphia, was divided as follows: St. Louis Car Company, 210 cars; Lamokin Car Company, 40 cars; Peckham, 125 trucks; Brill, 125 trucks. The Sperry Electric captured half the motors, balance going to General Electric.

CURRIER, MAYO & Co., is the new firm name of the successors to the well known concern of J. A. Grant & Co., Boston agents of the McIntosh-Seymour engine. C. H. Currier was the "co." of the old firm and Mr. Grant now becomes the "co." in the new, and while he will still give considerable time to the business, will leave the active management to the younger members, who thus succeed a large and well conducted business, in which they cannot fail to maintain the splendid record so long made by J. A. Grant & Co.

GENERAL SUPERINTENDENT ELLIOTT, of the Birmingham Traction Company, has adopted a novel scheme. The Birmingham Traction uses the Bemis double truck exclusively. Mr. Elliott is now turning them over and putting on rubber springs, which arrangement, he claims, makes them run much better.

THE CONSOLIDATED CAR-HEATING COMPANY, of Albany, N. Y., at a meeting held January 9, declared its regular semi-annual dividend of three per cent, payable February 15, 1894; transfer books to close from February 1 to February 16. The affairs of the company were reported in a prosperous condition.

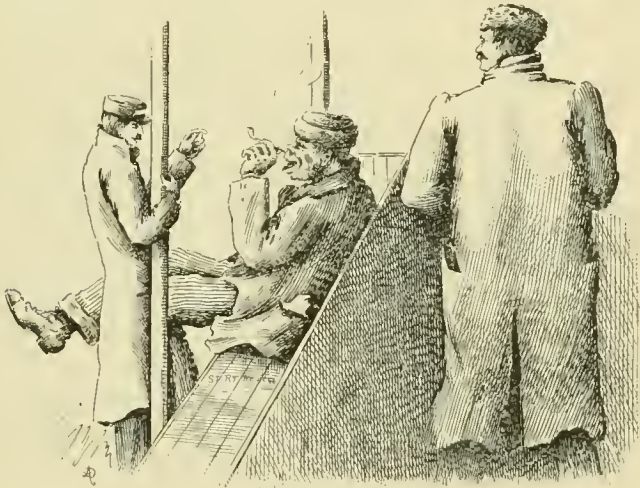

CONDUCTOR.—“Last call—Shell out or I'll put you off”

WHEN the Stanwood Manufacturing Co. does anything it is well done. This remark applies to the new catalogue “C”, just issued, which shows all styles of steel steps and running boards, together with measurements and diagrams. Five styles and one hundred sizes are in use on 468 roads. This implies merit.

THE annual meeting of the New Process Rawhide Company, of Syracuse, N. Y., resulted in the following offices and directors being chosen: President, T. W. Meachen; vice-president, Hon. W. B. Kirk; secretary-treasurer, A. C. Vosburgh; directors: Emil Laass, Jacob Amos, C. H. Duell and C. L. Stone.

THE SAFETY CLUTCH BRAKE COMPANY has been organized with offices at 4337 Lancaster avenue, Philadelphia, for the manufacture of a coupled clutch brake for street railway cars; C. E. Baird is secretary. Although the device has only recently been patented, it has been endorsed by several managers and street car builders.

THE GOUBERT MANUFACTURING COMPANY, of 32 Cortlandt street, New York, reports a good business in its improved feed water heaters, the sales for 1893 being over 100,000 horse power. It is also the sole manufacturer of the popular Stratton steam separator, the sales of which, during '93, were nearly double those of former years.

J. W. PARKER & Co., Philadelphia, agents for the Ball Engine Company, have taken the New York agency, as previously mentioned, and placed F. Schmerber and J. S. Du Vall in charge. Mr. Schmerber was for some time chief engineer of the Pierce & Miller Engineering Company, and Mr. Du Vall is well known to the trade in his connection with Mr. Chinnock.

CHAS. A. SCHIEREN & Co., have sent out a very neat little catalog, devoted exclusively to its perforated “electric” belting. These belts have had a phenomenal record and the rapidity with which they have come into general use is wonderful. The catalog has engravings of a number of the largest perforated “electric” belts now in use, and contains valuable reference matter.

SAMUEL LEWIS, 12 Lorimer Street, Brooklyn, reports a good trade in the well known Lewis diamond car mat, having recently equipped the last 50 cars built by Lewis Fowler for the Brooklyn City railway. Ever since 1869 the Lewis diamond mat has been known to the trade and besides a large general trade Mr. Lewis has equipped nearly every car in New York and Brooklyn.

SARGENT & LUNDY, engineers and millwrights, have removed from the fourteenth floor of the Monadnock to room 13 on the ground floor. Martin J. Insull has been added to the firm, and every department of power equipment will now be included within the range of the firm. They are western agents for the Crocker-Wheeler Electric Company, and have secured J. M. Atkinson as sales agent.

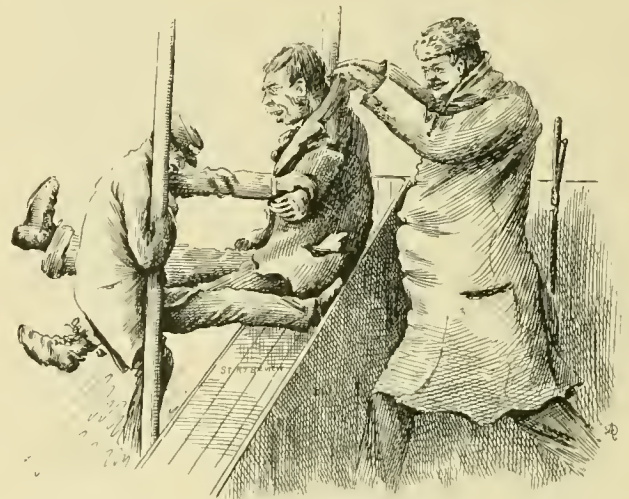

“Youz put me offen the car?”—!!!

THE METROPOLITAN ELECTRIC COMPANY has been made general western agent for the Standard Paint Company. The merits of the P. & B. goods are too well known to REVIEW readers to say anything more in their praise. The Metropolitan Company will keep a full supply of the goods on hand. Besides this the Chicago office is reopened in charge of William Weierbach, 871 Rookery.

THE JOHN T. NOYE MANUFACTURING COMPANY, is no longer represented in the west by Fairbanks, Morse & Co. All western business will be handled by the main office at Buffalo, until some further arrangements can be made for a local agency. All correspondence should be addressed accordingly.

GENERAL MANAGER ROGERS, of the Sperry Electric Railway Company, of Cleveland, is pushing the interests of his company prominently to the front, and that the claims for good quality in their motor are being recognized is evidenced in the recent order from the People's Traction Company of Philadelphia. Their order is for 125 of the Sperry motors, and was secured in the face of particularly active competition.



"Howly father! Oi niver see a little feller with sich a grip in me loife!"

THE STAR ELECTRIC LAMP COMPANY, Chicago, manufacturers of the Sunbeam lamp, has changed its name to The Sunbeam Lamp Manufacturing Company. The intent of this company is to furnish lamps superior in quality. Recently some discoveries have been made, as the result of the extensive experiments carried on, which, it is claimed, will greatly improve the quality and add to the value of the Sunbeam lamp.

THE W. S. HILL ELECTRIC Co. at 133 Oliver street, Boston, has kept its shops full of orders throughout the dull times. Their line of switchboards, switches, and rheostats is very well known by all street railway men. They will soon put on the market a new lightning arrester which has many superior points. The switchboards of the new power houses of the Philadelphia Traction Company will be furnished by them. This is one of the largest contracts of this kind ever made.

CHARLES A. LIEB, for the past four years mechanical engineer for the Edison General Electric Company, and well known in the street railway field on account of his numerous inventions in that line, has associated himself with the White Manufacturing Company at 556 West 34th street, New York City. Mr. Lieb's large acquaintance in the trade will add much to this already very popular firm, which is well known as one of the oldest wheel and supply manufacturing concerns in the country. General Manager Edward White apprised us of the fact that even a more complete line of his specialties will soon be put on the market.

AMONG late important items of news is one that tells of the incorporation of the Graham Equipment Company in Rhode Island, with a capital stock of \$100,000, paid up. The officers are, J. H. Graham, president; G. S. A. Gardiner, vice-president and treasurer; E. G. Rodgers, secretary, with offices at No. 258 Washington street, Boston, and No. 232 Carter street, Philadelphia, Pa. Works have been established in Boston and Philadelphia, and a fine lot of orders already on the books. A recent call for Graham trucks is for one concern that is equipping four roads.

THE utility and safety of iron structures is becoming more widely known as better construction of some kind becomes necessary. The Berlin Iron Bridge Company, of East Berlin, Conn., is putting the roof on a building for the United States Government, at Fort Wadsworth, N. Y. The building is 41 feet by 231 feet, the roof being made entirely of iron—iron trusses covered with corrugated iron. The new works of the Stanley Electric Manufacturing Company, at Pittsfield, Mass., will be entirely of iron, designed and built by the Berlin Iron Bridge Company.

A HANDSOME gold embossed cover and eighty pages of valuable matter comes to the REVIEW office as the catalogue of the Bass Foundry & Machine Company, of Fort Wayne, Ind. It gives, with illustrations and full data, the particulars of the engines, boilers, pumps, parts, repairs and furnace specialties made by the Bass Company. No steam user or prospective buyer can afford to be without it. Measurements for boilers, engines and furnaces, and standard price lists for belting, asbestos and the like are also given. It will be sent on application to any one interested.

THE GENETT AIR BRAKE, the only air brake on the market adapted to street railway work, are full of orders, and their works in Chicago is a very busy place. While an excellent working brake from the first, it has been constantly improved as suggested from more extended use. They now offer an improved "Duplex System of Air Brakes" suited to both electric and cable cars and which requires only eight inches of axle space. This brake serves all the requirements of a wheel brake and its use cannot fail to largely reduce grade accidents, which have been so numerous and disastrous of late.

THE GENERAL ELECTRIC COMPANY has secured a large number of recent contracts in the street railway field. The recent Philadelphia contracts of the People's Traction Company gave 125 equipments of G. E. 800 motors to the General Electric with type K controllers. The remaining 125 went to the Sperry Company, of Cleveland. Other contracts embrace: 20 car equipments for the Union Railroad Company, of New York; 25 for the Steinway Railroad of Long Island; 1 700-horsepower generator for the same and 8 M. P. 300 K. W. generator for Cincinnati, O.; 10 car equipments for St. Louis Street Railway Company, St. Louis, Mo.

## RAILWAY EQUIPMENT LIABILITIES.

The statement of Receiver Geo. O. Fairbanks, of the Railway Equipment Company, is on file at the Cook county clerk's office, and reads as follows:

ASSETS.	
Estate, real and personal	\$ 5,141.41
Accounts deemed good	3,568.97
Accounts deemed doubtful	15,317.71
Accounts deemed desperate	15,480.15
Total	\$39,508.24
LIABILITIES.	
Accounts owing	\$22,973.01

## REPORT OF THE CANAL TROLLEY COMMISSION.

The New York state report of the canal trolley experiments gives two tables which average as follows:

The slight difference in the horse-power in the doubling of the speed will attract attention and is not easily explained.

AVERAGE SPEED.	AMPERES.	VOLTS.	E. H. P.
2.65 miles.	63.08	294	24.87
4.24 "	63.55	313	26.21

## IT TELESCOPED A BARN.

When car 24 of the Steinway Electric Railway, of Long Island, New York, started out on its trip it had no idea of going into the barn so soon it did. But it was not the car barn. The barn belonged to Tom Kavanaugh. A steep grade on Lockwood street compounded with a curve was the cause of the car's vagary and leaving the track at a high speed, the recreant vehicle went smash into the side of the wooden affair, carving its way through the structure and stopping in the baled hay pile. The fifteen passengers were uninjured and the car needed but a few repairs to take its place on the line next day. The motorman's escape was miraculous.

## MAKING THE STOCKHOLDERS USEFUL.

Two workingmen were discussing serious subjects. Quoth the younger: "I say, Bill, what's them 'ere joint stock companies?" "Well, I'll explain it to yer. You and Jim and half a dozen more of our mates puts up a penny each and buys two ounces of bacca and a clay. Then I calls myself the managing director, and I sits down and smokes that pipe and bacca. D'ye see?" "Yes, but where do we come in?" "Oh, you're the shareholders; you looks on and spits."—Natal Witness.

## A TIP.

Oh! they are wise  
Who advertise  
In Winter, Spring  
And Fall;  
But wiser yet  
Are they, you bet,  
Who never let up  
At all.

—Cincinnati Tribune.

## A FEAT OF THE PFINGST FENDER.

The illustration shown herewith is of the Pfingst fender, made by Lonis Pfingst, 53 State street, Boston, and adopted by and in use on the Brooklyn City, of Brooklyn, the Lynn & Boston, and the Springfield, Mass., Street Railways, with a number doing duty on the West End Street Railway of Boston. This fender was also recommended by the fender commission of Boston, and the railroad commission of Massachusetts.

A recent incident and the averting of an accident to two children, cause much favorable comment on the Pfingst device. Two children, one aged five, and the other three, were struck by a Tremont street, Boston, car, No. 20. The children were directly in front of the car, which was running at speed. To the surprise and joy of all bystanders and passengers, when the car was stopped the two youngsters were found curled up on the Pfingst fender, yelling like Indians, because they had lost two

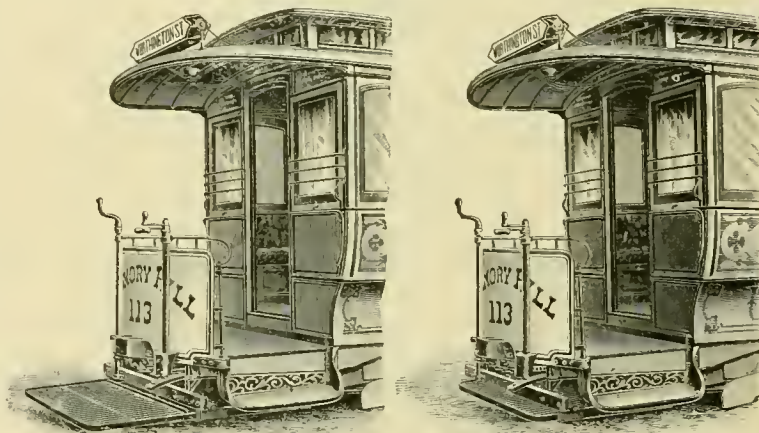

FENDER PULLED OUT READY FOR USE.

FENDER PUSHED BACK OUT OF USE.

cents! No other damage was caused and the pair walked home.

The fender is a light strong platform, suspended from the truck and made of steel and malleable iron. The fender is held nearly level, about three inches above the track. It projects about three feet in front of the car when in use, and can be pushed clear under the car when necessary. The fender will not engage with the track or slight immovable obstruction, even when weighted, and it may be easily replaced if necessary, when bent after use.

Mr. Pfingst, also makes for the street railway use an adjustable spiral spring, an improved ratchet brake handle, a duplex hammer foot gong and an eight sided sign for direction of cars.

The inventor and manufacturer is a rising man in the street railway field. He was born in New York City, attending the public schools there until the age of fifteen, when he entered the employment of the John Stephenson Company, as an apprentice, at the same time attending Cooper Institute, where he was graduated from the mechanical department. When 22 he left the Stephenson works and joined the forces of the J. M. Jones Car Company, then at Schenectady, where he remained a year.

The next two years were spent in New York City in the business of pattern making, moulding and machine work. Next at Yonkers, N. Y., and finally as superintendent of the street car department of the Pullman works, gave him the finishing touches for thorough education in street car affairs. It is not remarkable then that his next place was as master mechanic of the Third Avenue Railway of New York City, under General Manager Robertson, where he remained two years, resigning to become master mechanic of the Boston lines, at that time consolidated. There he remained five years. During this latter connection Mr. Pflugst was well-known as the inventor of many valuable specialties in the line of snow-plows and smaller devices.



LOUIS PFLUGST.

Resigning in the fall of 1892, he opened a general supply business, and surely none is better able to judge of the necessities of street railway work than one of Mr. Pflugst's wide and thorough experience. Probably no one ever had better opportunity to study the supply business from the buyer's side. Mr. Pflugst's latest honor is his election to the general management of the Ames Register Company, which has abundant capital and the best of prospects.

TEST OF WEBSTER SEPARATOR.

The Warren Webster Company, of 2 Canal street, Chicago, are congratulating themselves over the results of the tests made by George H. Barrus, C. E., of Boston, on their steam and oil separators, at the World's Fair; so much so, in fact, that the report is being published by them in full, in a neat circular. The separators, one for live steam and one for oil, were attached to a duplex steam pump. Between the steam separator and the boiler was inserted a drip chamber. When the drain valve of this drip chamber was closed, the condensed water, of course, overflowed, and some or all of it ought to be caught by the separator.

The results of this test was as follows, which show that the separator intercepted practically all the moisture introduced.

1. Weight of water drawn from the separator per hour when drain pipe of drip chamber was closed.....	26.1 lbs
2. Weight of water drawn from the drip chamber per hour when the chamber was drained .....	21. lbs
3. Weight of water drawn from separator per hour when drip chamber was drained.....	4.5 lbs
4. Total weight of water drawn from drip chamber and separator when both were drained.....	25.5 lbs
5. Weight of steam passing through separator per hour.....	120. lbs
6. Percentage of moisture in the steam intercepted by the separator.....	17.5 %

With the pump using steam at the rate of 120 pounds per hour, fifteen ounces of "Capitol" cylinder oil were used in two hours, of which 86.7 per cent was recovered by the oil separator placed in the exhaust.

THE "CHICAGO" TROLLEY BASE.

This trolley base is the invention of J. R. Griffiths, 129 East Erie street, Chicago, who has just placed it on the market. It is made up of very few parts and all those are interchangeable. There are no chains to break every time the trolley comes down to its limit. An even pressure on the virtue of the peculiar the trolley pole, by age on the pole is in- rises. The bearing large and as provisions

down to its limit. An wire is maintained by shape of the base of which form the lever. creased as the pole surfaces are all very are made for taking up

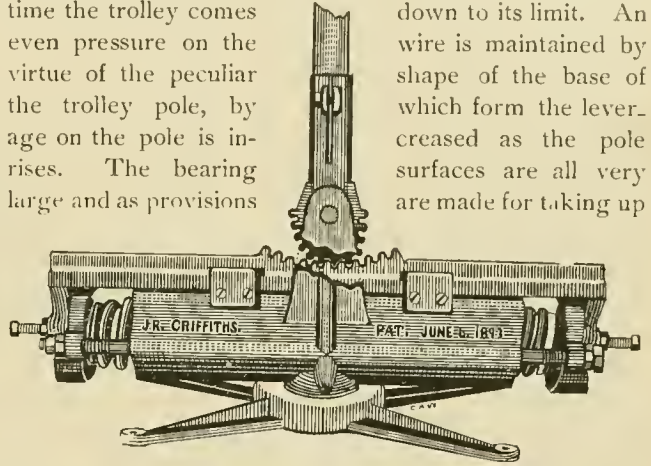

THE CHICAGO TROLLEY.

all wear, the base ought to last a long time without any repairs.

The feature of equal pressure for all heights of wire is one sought after by many but attained by few, and Mr. Griffiths is to be congratulated on his success. It is highly commended by the management of the Whiting & East Chicago Electric Railway, on which road it has been extensively tried.

OBITUARY.

William Henry Allen, treasurer of the Union Street Railway, of New Bedford, Mass., died January 15, at his residence in that city, at the age of 41. Mr. Allen was closely identified with steamboat and railway enterprises all his life, and for many years was treasurer of the New Bedford & Fairhaven Street Railway. His amiable disposition gained for him many friends. He left a wife and four children.

THE Douglas-Lanxey electric line, in the Isle of Man, is in successful operation and now Lowcock, Hill & Company, of Manchester, are about to inst all a road from Douglas Head to Little Ness, on the same little isle.

AS WE go to press, a fearful blizzard is sweeping the central states. In Chicago it is the worst storm with one exception in twelve years. Cable lines are running, but some horse lines are abandoned, and on others, four horses to a car find great difficulty in pulling through.

THE Annual dinner of the street railway presidents, of Philadelphia, met January 31st, at dinner to discuss affairs together. There were present the secretaries, members of the board of directors and other officers of the roads and a number of distinguished gentlemen of other callings.

## PATENT OFFICE GOSSIP.

Conduit patents this month 8. Fenders 7.

H. R. KEITHLEY, obtains a patent (512,711) on a device already well and favorably known to our readers as the "Chicago" rail bond. It is one of the very few devices making a perfect moisture proof rail contact. See illustration.

A NOVEL principle of trolley construction is that described in 513,023. The current collector or trolley wheel consists of two conical rollers mounted on roller bearings. The wire runs between these. See illustration.

THE trolley oiling device 513,067 consists of a hollow fork suited to holding oil and apertures for conveying the oil to the axle, as shown in the illustration.

A VERY peculiar motor construction for railway motors is the invention of Mr. Lamme, of Pittsburg, (513,401)

## THE CHICAGO OFFICE OF THE GENERAL ELECTRIC.

After many rumors of change of the Chicago offices of the General Electric, it has finally been given out that the building at 173 Adams street is to be deserted, and the force consolidated and centralized at the more convenient headquarters, the Monadnock block, corner Jackson and Dearborn streets. Some six thousand square feet of floor space has been taken at the south end of this hive of electrical industry, and the actual removal of the household is already under way. This is in direct line with the policy of consolidation and retrenchment now carried on by the General Electric, which began by the removal of the main office force, in New York, to the factory at Schenectady. The Chicago office will be considerably reduced by the transference of the principal part of it to Schenectady, and the abolition of some of the service.

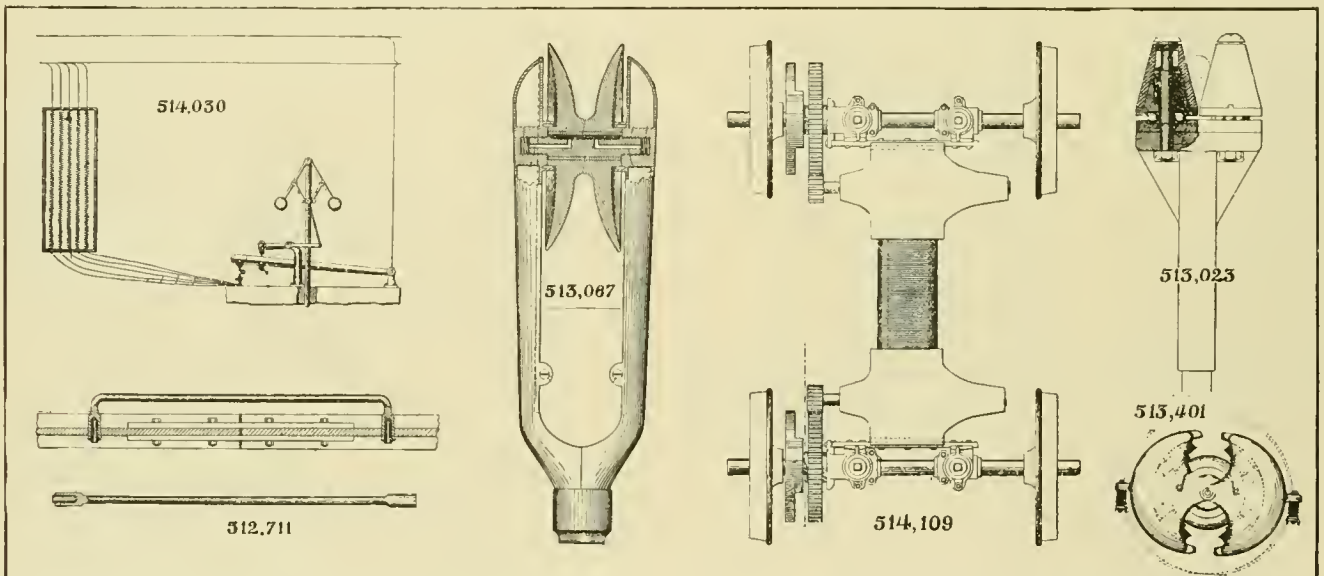

and is the property of the Westinghouse Company. The two halves of the field magnets are independently sleeved upon the axle and flexibly suspended from the truck or car body. It has always been considered a necessity of motor design to have the fields occupy a perfectly rigid and fixed position. If this invention is ever put on the market it will be a radical change from existing forms. See illustration.

F. E. PRITCHARD, of Oswego, has secured a patent on one of his well-known regulators, for use in water power plants. It is simply a governor which as the speed rises cuts in more resistance, throwing more load on the dynamo. See illustration (514,030).

NUMBER 514,109 is another Winkler single magnetic circuit motor truck design. See illustration.

NUMBER 514,109 is another Winkler single magnetic circuit motor truck design. See illustration,

## INTERURBAN AT SHEBOYGAN, WIS.

F. I. Sæmann, secretary and treasurer of the Sheboygan City Railway, of Sheboygan, and H. E. Thomas, of the Dairyman's Bank of Sheboygan Falls, have purchased the charter rights of the Sheboygan and Sheboygan Falls Transit Company, and have secured exclusive franchise, for ninety-nine years, over the toll road, between this city (population 23,000) and the village of Sheboygan Falls (population 1,500) five miles distant. The kind of material used in construction of tracks and motive power is left optional with the company. The track will be laid on one side, away from the roadbed, with T rail.

Considerable bonus is being pledged, besides passengers, mail, express and freight will be carried. The fare one way will be fifteen cents, round trip tickets twenty-five cents, which gives passengers a transfer over the lines in the city.

The Sheboygan City Railway, is considering the advisability and cost of changing from animal to electric power.

THE CRAWFORD FENDER.

Two devices which are rapidly becoming known to the street railway field, are the wheel guard fender and the pick up fender, invented by R. A. Crawford, and made for the market by the manufacturing company of the same name. We illustrate both herewith. The wheel guard fender board is placed in front of the wheels, as shown in the illustration, under the cars, usually without a top screen. Where the wheels come out to the car body front a steel lattice screen is used. In contact with a movable obstacle, the fender board rubs the ground and pushes the body forward. Meeting an immovable object the fender board turns under, then upwards, passes over the object and resumes its normal position. These movements are occasioned by the use of maximum, minimum and medium power springs and the strength of the material used.

The pick-up fender is also automatic and independent of the motorman. It has a backward down-yielding movement to the road bed, which lessens the impact of anyone falling into the fender and also prevents passing



R. A. CRAWFORD.

A NEW SUPPLY COMPANY.

We take pleasure in informing the trade that the Wallace Electric Company has been organized for the purpose of conducting a business in electrical goods as manufacturers and manufacturers' agents, at 104 Michigan avenue, Chicago.

Their line embraces alternating current generators, motors, meters, transformers, etc. Wires and cables for all electrical purposes. Incandescent and arc lamps, measuring and indicating instruments, switches, etc.; also a full line of electrical street railway appliances and supplies, and a few carefully selected specialties.

The officers and management of the company are well known to the trade. The general manager, J. B. Wallace, has been actively identified with electrical industries from the earliest experimental stages of electric lighting in this country. William S. Hine, president, has had a large experience in this business through his connection with the United States Electric Lighting Company, and the Westinghouse Electric and Manufacturing Company, as general district agent.

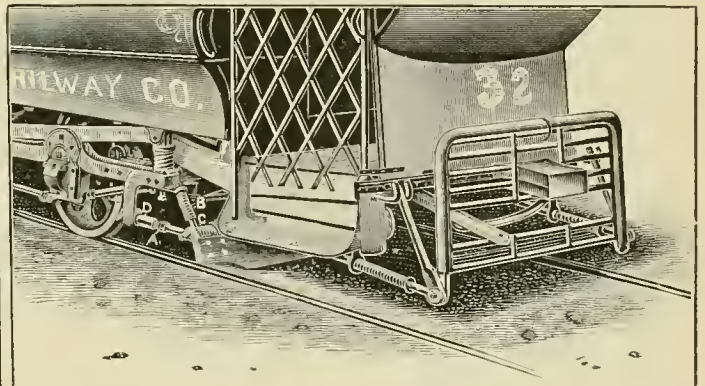
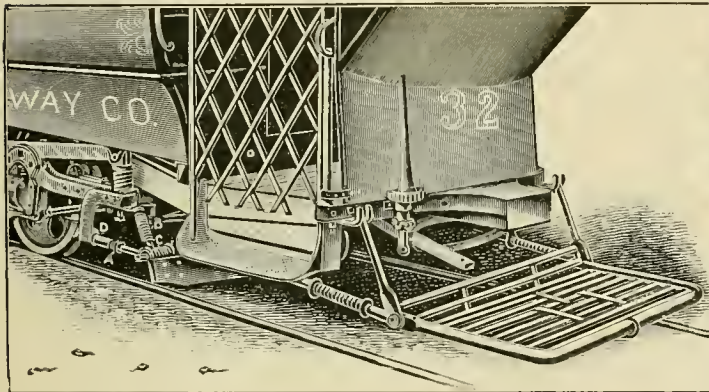

CRAWFORD FENDER IN AND OUT OF ACTION.

thereunder. It folds up over the draw bar and bumper so as not to interfere with the sliding action of the draw bar, when coupled to another car in going around curves and both ends of the car may be equipped and yet take up no more space in the barn than if not equipped. Its action is quiet and effective and as the material used in construction is the best of steel and iron, it may be depended upon in every emergency.

R. A. Crawford, the inventor, is a practical man of thorough theoretical training. Although a young man, his experience has been wide and varied, and his business education complete. In 1891 he began the investigations and experiments that have been so successfully concluded as above narrated.

ISAAC T. VAN DUZER died in St. Paul, January 4, at the age of 77. In 1841 he built the first street railway in New York City, and shortly afterwards built the Hudson River Railroad, from Poughkeepsie to the city.

Max A. Berg, secretary of the company, is well known as the former manager of the street railway department of the Ansonia Electric Company, and M. M. Wood, whose special devices are well known for street railway construction, will be electrical engineer in this department.

The company is not electrical supply dealer, but manufacturer and manufacturers' agent.

Catalogues, price lists, etc., are in press and will be mailed on application.

They are thoroughly equipped to promptly and satisfactorily handle your business and solicit orders.

If he said it he ought to be retired. A Grand Rapids' paper recording the visit of an electrical engineer from another town, reports him thus: "I find that the Grand Rapids system is one of the best, if not the best, in the country. The method of running the electric current through the motors in use here, is one of the most inexpensive and at the same time most servicable."

## THE MONTH ILLUSTRATED.

The last thirty days have been pretty well crowded with street railway incidents. Fires, fatalities and faction have fatigued managers and men. For instance: In Long Island, an electric car ran away down grade and telescoped a barn. It hurt the car some and spoiled the barn, but did not injure the 15 passengers. Then, too, rain storms in San Francisco washed a good many tons of sand on to the railroad tracks, washing away and filling up cable conduits. The General Electric Company took its penates and its bed, and walked to Schenectady, where it now keeps house. Niagara's water power was harnessed some time ago, but during the month the faucet was turned and the wheels go round now. Our own Chicago Alley L sagged a couple of feet for a section,

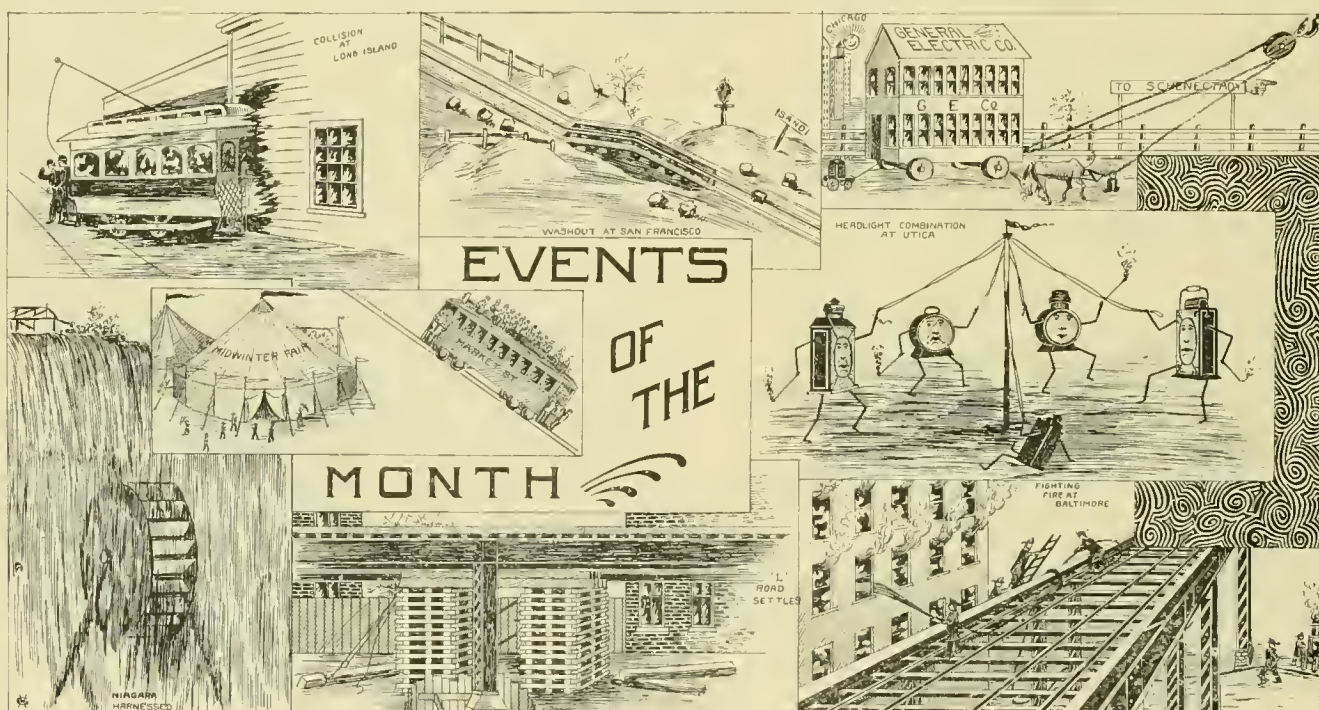

because some careless workmen dug under it. No one was hurt, but several passengers of the two train loads on the structure at that time, fainted.

At Utica, the headlight manufacturers of the country came to a council of war and decided that the union there, was light, and so a combination was formed as related elsewhere in this issue.

The Lake Roland L. in Baltimore, found itself a great convenience for the fire laddies, when an adjacent building took to smoking. Last, but not least, the Midwinter Fair opened and the artist feelingly draws a stuffed car.

GEORGE BARNETT, president of the board of public works of St. Louis, favors the underground placing of wires in subways, somewhat similar to those used at the World's Fair, except that they would be set in cement and made permanent in character. His estimate of the cost is \$50,000 per mile.

## ATLANTA'S NEW ROAD.

The popular resort of Lithia Springs is about to be connected with Atlanta, Ga., by an electric line, to be called the Lithia Springs Electric Railway. Henry Camp, of Covington, is president; Thomas Camp, secretary and treasurer and B. F. Curtis, general manager. J. W. Hobson, of St. Joseph, Mo., was main promoter and will remain in Atlanta until the line is built and running. The cost will be \$300,000, and extensions proposed, when this is done, as much more.

The trips to Lithia Springs will be made uniformly in one hour, but it can easily be made in forty or forty-five minutes. It is believed that thousands will this summer enjoy the breeze, the fresh air, and lovely scenery that the new electric railway will offer to its patrons.

## NEW PUBLICATIONS.

ENGINEERING EDUCATION, STREET RAILWAY REVIEW, Chicago. Price, \$2.50. The proceedings of the Engineering Education section of the World's Engineering Congress, last summer, have been printed in book form. As the number for sale is limited, those desiring copies will do well to send in their orders early. The papers it contains will be a reliable adjunct to an engineering library.

DYNAMO AND MOTOR BUILDING FOR AMATEURS. By Lieutenant C. D. Parkhurst. W. J. Johnston Company, Limited, 41 Park Row, New York. Price, \$1. A clear, concise set of instructions with working drawings for four types of machines. Technical points are taken up in connection with the larger machines which are of value to the professional as well as the amateur.





WINDSOR & KENFIELD,

PUBLISHERS AND PROPRIETORS.

269 DEARBORN ST., - - - CHICAGO.

Published on the 15th of each month.

SUBSCRIPTION, - - - TWO DOLLARS.

FOREIGN SUBSCRIPTION, - - - 20 SHILLINGS.

Address all Communications and Remittances to THE STREET RAILWAY REVIEW,  
269 Dearborn Street, Chicago.

H. H. WINDSOR,  
Editor.

F. S. KENFIELD,  
Business Manager.

**CORRESPONDENCE.**

We cordially invite correspondence on all subjects of interest to those engaged in any branch of Street Railway work, and will gratefully appreciate any marked copies of papers or news items our street railway friends may send us, pertaining either to companies or officers. Address:

THE STREET RAILWAY REVIEW,  
269 Dearborn Street, Chicago

Eastern Office, Room 14, No. 126 Liberty Street, New York.

This paper member Chicago Publishers' Association.

Entered at the Post Office at Chicago as Second Class Matter.

VOL. 4. MARCH 15, 1894 NO. 3.

ONLY forty days until the festive summer cars will begin to make their debut, but each one deserves a thorough overhauling in the meantime.

A RULING by the Supreme Court of this state, recited in our legal department, emphasizes the extreme importance of thoroughly instructing drivers as to special care in operating a car past a point where an infant may be near the track. The courts almost invariably place the entire responsibility for discretionary care on the servant of the company, as was ruled in the case mentioned.

OUR illustrated description this month of the commencement of construction of the electric railway in Madras, India, marks the beginning of a new history of transportation in the far East. Although the event occurred within the past sixty days, the REVIEW, with customary enterprise, secured photographs of the inaugural ceremonies which will be found interesting glimpses of Oriental life.

THE snort of the iron horse, among the hills and valleys which surround Jerusalem, is no less indicative of the invasion of accidental ideas in the Orient than is the electric railway which is about to be constructed in Cairo, Egypt. There may be nothing new under the Egyptian sun, but we cannot but express the firm belief

that could the followers of the Ptolemies free themselves for a day, of their mummy wraps, with the transformation from ox-cart to electricity they would in all honesty have to own that the new conveyance was ahead of even the gold plated chariots of the good old days. An inclined plane up the pyramids and a pair of arc lights to give sight to the Sphynx at night should now be slated as possibilities of the no distant future.

THE storage battery system at Birmingham, England, about which so much has been said, and for which so many claims have been made, has finally been decided to be unsuccessful, so much so that the directors of the Bristol Tramway Company, who investigated the system, have recommended to the shareholders that the accumulator method as practiced at Birmingham after a thorough test under the best possible conditions, has been found excessive in cost and uncertain, and they therefore recommend the overhead trolley for the city of Bristol.

THE management of the San Francisco & San Mateo electric railway, on which the terrible fatality occurred last month, owing to a motorman losing control of his car on a steep grade, now announces, with great flourish of trumpets in the daily papers of that city, that hereafter all motormen will be examined as to fitness and ability before being put in charge of a car. The almost criminal lack of common sense which could permit men to drive even a horse car without proper examination, is a remarkable confession for a street railway company, and had better have been left unpublished. Under the past conditions of management the wonder is that only two fatal runaways had occurred.

ONE of the advantages (!) of municipal ownership of street railways is illustrated in the very tempestuous controversy which has been going on for several weeks past in our neighboring city of Glasgow, Scotland. When the road was built by a private corporation it was decided to run cars on Sunday. At first only a sufficient number were put out to transport the attendants on church service to and from their homes. While this was undoubtedly very wicked, still a great many piously inclined people availed themselves of the opportunity to attend the sanctuary who otherwise through bodily infirmity and lack of means could not otherwise have walked or hired a carriage. Gradually other worshippers came to use the same gospel chariots to attend meetings, where sun and sky, open air and flowers and green grass constituted the ritual and litany, of which they were deprived during six long days and nights of toil and drudgery. But the attendance on Nature's choir grew to such alarming proportions it finally came to be considered sinful by a very consequential portion of the good citizens, and now, that the city government has it in its power to permit or refuse the Sunday car service, there has been a most determined fight to stop the wheels. How strong this sentiment is evidenced that, on the final ballot, one-third the town council voted to discontinue the service.

ALTHOUGH long distance transmission for railway work has as yet been entirely on paper, there is prospect that the near future will see the installation of several plants of this nature, aside from the railway stations, which will eventually be run from the great Niagara plant if it proves as economical a source of power as expected. As the matter is being agitated, the statement elsewhere, outlining the opinion and policy of the Cie de l'Industrie Electrique, Geneva, will be of interest, as presenting one side of the case. This company, of which R. Thury is the electrician, has made several installations of the type described. The company's position, will, of course, be questioned by many, but it shows the practicability of direct current transmission in many places not usually thought to be suited to it.

THAT even the editors of leading English journals have much yet to learn on the operation of street, or, as they delight to term them, tram cars, is fully evidenced in an editorial in "Industries and Iron." The editorial ignorance is thus forcibly displayed:

"An American journal actually takes up seriously the question of the value of track brakes, or brakes which operate by pressure on the rail. How any sane engineer could ever get the length of writing on such a subject as the substitution of brakes acting on the rail for brakes acting on the wheel is inconceivable, but that the subject should be dealt with seriously, and the reasons, which are apparent to any thinking mind, carefully worked out and detailed, is even more strange. Apart from the wrong theory, the bare suggestion of a "track brake" brings to one's mind endless practical objections. This proposal is on a par with that which, by the way, is now being carried out in Boston, namely, the electric welding of the joints of some miles of tram line."

Track brakes are usually used as auxiliaries to the ordinary wheel brakes, and very successfully. In San Francisco alone there are several hundred cars so equipped, and in other cities where the grades are few and light, the track brake is equally serviceable. Our English brother may not be so far amiss when he places the track brake "on a par" with electric rail welding, for the latter seems to be the coming solution of the joint problem.

FIRE insurance matters are certainly in a very unsettled and unsatisfactory condition. The underwriters, finding that their losses are on the increase, have gone about in a blundering way to decrease them, without getting at the root of the matter, by looking well into the condition of the risks they insure. Instead, they make the innocent suffer with the guilty, and adopt sweeping rules which are only partly enforced, or are enforced in such a way as to be of no great practical value to themselves or anyone else. For example, a trolley circuit motor, carefully installed, may be run in a building next door to a lot of lights wired up in a criminal fashion. The building with the motor will be rejected, and the one with the electric lights accepted, with possibly a slight raise in rates. Very likely the accepted building burns down, and the underwriters raise the rate all along the line.

The plan nominally adopted by the underwriters, and described in another column of adopting a standard of construction and charging for deficiencies, would be an excellent one if carried out. At any rate, if mutual insurance is to be inaugurated, as now seems very possible, the rocks struck by the old line companies must be avoided, and the results of their experience made use of. The rules and rates will bear close inspection by both policy holders and prospective mutual insurance promoters.

It is strange that those who oppose the trolley seem utterly to forget that it is usually simply a matter of choice between the trolley and some worse system. The remarks of Mr. Preece, commented on in another column, are a good example of this. The trolley is like many another engineering device; not without its drawbacks, but at the same time the only thing available to reach a desired end in many places. Trolley opponents seem to have a vague idea that some other system of mechanical traction is practicable for places where the trolley is usually proposed. Briefly, the present status of street railway propulsion is as follows: The mechanical difficulties of cable traction limit it to lines with few curves, and its cost always makes a heavy traffic necessary for profitable operation. The only electric conduit systems which have shown any prospect of being a success in ordinary streets, cost nearly as much as the cable to build, and while the cost of operating on light loads is not proportionately as great as with the cable, the field for the electric conduit road is but little larger than that of the cable road. If storage batteries are ever successful, it will be only on level lines, with light traffic. This leaves the trolley as the only practicable system in the largest part of the street railway field. This outlook may not be bright for those who have been expecting a substitute for the trolley, but it is simply looking matters squarely in the face.

OUR illustrated description last month, the only one ever published, of the aerial railway at Knoxville, Tenn., had only reached our readers when the news of the accident on that line was telegraphed to all parts of the country. While it is extremely doubtful if that form of transportation will ever find any considerable adoption, there are a few places where it is the most feasible means of conveyance. With the record of the fatality at Knoxville, it is extremely unlikely many similar lines will be built in the near future, and yet the disaster is unfortunate in an engineering sense, as many ropeways are doing magnificent service in mountain districts and operating under natural conditions far more dangerous than the one mentioned. The blame for failure would seem to rest with the constructing engineer and operators of the line. A system of counterbalancing weights could easily and should have been provided, which would have made impossible the accident which occurred, and a grip brake of sufficient length and strength to clutch the main cables would also have insured safety.

**MADRAS ELECTRIC RAILWAY BEGUN.**

The Orient to be Quickened with Advanced Electrical Ideas from the Occident.

The presidency of Madras is a system of dependent and allied native monarchies under British dominion. Its area is 139,000 square miles, and its population numbers 35,000,000 souls. Madras, the capital city, although a coast town, has no harbor, being reached from the roads, seven miles out to sea. Its population in 1891 was 450,000. It was founded in 1639 by the British and since has had a number of changes of ownership, resulting again in British possession. The town is divided into Black Town and English Town, the former being great-

supervision of Thomas Parker, M. I. C. E., M. I. E. E., F. R. S. E., director of works of the Electric Construction Company, of Wolverhampton, England.

It will be a conduit system, and is carefully worked out in every detail to allow a dry conduit and perfect contact. The line will run in the center of the road and will be double tracked from a point on Esplanade road, opposite the Christian college, to the central power station at Egmore. The right hand rail is of the ordinary girder type, weighing 56 pounds to the yard. The rail will rest



THE ESPLANADE, MADRAS, INDIA.

est in population and area and the latter the most powerful.

Up to date the system of transportation has been a series of primitive cabs, sedan chairs and bob-tail horse cars. But even the lazy Indian is getting tired of those methods and demanding something better.

The Anglo-Saxon is to meet the demand, and when an Englishman does anything for the Provincial he does it well. So with the street electric railway in Madras.

The Madras Electric Tramways Company, which is to furnish the miscellaneous population of the city with convenient modern and rapid intramural transportation is, naturally, an English corporation. The road is planned by and the materials manufactured under the personal

on a longitudinal bed of concrete and on cross sleepers every five feet.

The left-hand rail coming from the power house, is a slot rail bolted to cast iron yokes buried two feet below the road level and resting on nine inches of concrete. The yokes are placed five feet apart. The yokes are cased with cast-iron casing, and over the top is a cast iron covering with interstices for the laying of paving. The conduit thus formed is drained adequately by connection with existing sewers and through special pumps and drains where extra precaution is necessary. The road is standard gauge and tied at intervals. The rails will be laid six inches above the present road level at certain points and the road afterwards graded up. This

will be of untold advantage to the city, as it will then be necessary to grade and repair these streets at present almost if not entirely uncared for. Another advantage expected is that the now miscellaneous collection of ox-carts, sedan-chairs and mules, termed by courtesy, street traffic, will be compelled to "keep to the left," obeying the "rule of the road." At present the careless Indians mix indiscriminately down-going and up-going traffic.

On January 10 the first earth was turned to begin the construction. At an early hour the engineering corps was busily engaged in preparing for the ceremony in a space previously fenced off, and a warning sign was put up to keep as many as possible of the curious natives from thronging the party.

Engineer Robins stands at her left with the shovel, and Assistant Engineer Torrance at his back. H. V. Faulconer stands by the transit and his assistant, Engineer Beveridge, just behind him. To the right, Commissioner Simpson is next the contractors' sign, with Assistant Secretary Salisbury to the rear. Managing Director Chalk stands at Mrs. Chalk's left hand.

The engraving on page 131 shows the same place after work had begun. The native laborers and the higher cast natives make an unique scene.

The engraving of the power house in course of construction shows the delightfully simple method of getting the brick to the bricklayers. The costumes of the laborers are as simple as their methods.



MADRAS ELECTRIC TRAMWAY—WORK COMMENCED ON CENTRAL POWER STATION.

At 8 o'clock, J. J. Robins, chief electrical engineer, representing the construction company, requested Mrs. Chalk, wife of managing director S. A. Chalk, to turn the first "sod," in the presence of Mrs. Faulconer, wife of the operating company's chief engineer and manager; Mr. Chalk; H. V. Faulconer, chief engineer; Engineer J. J. Robins and their assistants; S. D. Simpson, deputy commissioner of police, and others. In the excellent view of the proceedings shown, the natives in their Indian garments, the High Court buildings on the left, and the Free Church on the right, may represent church, state, and the native population, while modern scientific achievement is shown by the little Anglo-Saxon group in the center. The lady with the pick is Mrs. Chalk,

As in the southern states in this country the bricks are carried on the head, and the latest in dress reform is demonstrated in a manner at once simple and economical. Both sexes are employed in the work.

This beginning of electric railway construction on the Indian peninsula promises much for future enterprise, and who knows but that our Aryan brethren may yet be spurred from their Oriental slumber by the 500-volt current?

THE suit between Mr. Mason and Mr. Shaffer concerning the ownership of \$25,000 bonus for the sale of the Indianapolis street railway is on trial before Judge Baker of Indianapolis.



HIGH COURT BUILDINGS.

FREE CHURCH BUILDINGS.

MADRAS ELECTRIC TRAMWAY COMPANY, INDIA—BREAKING THE ROAD, ESPLANADE—JANUARY 10, 1894.

### HALF FARES.

Interesting Facts from all parts of the Country, Boiled Down for Busy Readers.

THE Lake Roland Elevated Road of Baltimore has paid its last quarter's park taxes, amounting to \$3,115.08. This indicates gross receipts of \$35,056.44 for the quarter.

A PASSENGER, on the rear platform of a city railway cable train, in this city, was held up by three men and relieved of \$500 in cash and \$25,000 in valuable papers.

THE Tacoma street railway employes will give a day's wages each to the cause of the Inter-State Fair, to be held at Tacoma.

THE Richmond City & Seven Pines Railway is sold to the Richmond City Electric Railway for \$50,000. The line traverses the battlefield of Seven Pines.

THE injured of the East Liverpool, O., trestle accident, on Thanksgiving day, ask damages. One wants \$10,000 for loss of his wife, and another \$5,000 for general injuries. Public sentiment is with the railway.

SIXTY senior students in the Lawrence, Kansas, High School, wrote essays on "What a Newspaper Should Be." The essay that carried off the prize read: "A newspaper should be read and paid for."

AN employe of the Selma, Ala., recently cut a wire in a careless manner and received the full force of the current. He fell 18 feet to the ground from the pole, seemingly dead. He was resuscitated, finally, but has no memory of anything previous to his fall.

THE Janesville, Wis., Street Railway Company, made \$1,550, net, last year, and Manager Proudfoot is proud all over. The report shows receipts, \$12,601, total expenses, \$11,050. The old board of directors was reelected.

THE new Mt. Adams & Eden Park power house planned by Engineer Bert Baldwin of the company, will be 50 by 70 feet, one story, constructed of iron, brick and stone. It will contain two 800-horse-power engines and four 400-horse-power generators.

The electric railway scheme in Dublin, Ireland, is to run a line from the city to the Hill of Howth. The Dublin Tramways Company asks the concession. When this line is completed feeders will be built. S. G. Frazer, C. E., is the engineer.

THE president of the Rochester, N. Y., Street Railway Company, John N. Beckley, has issued a "special caution" order to motormen, for the spring months, to look carefully after children playing on the streets and going to and from school.

THE British Trade Journal says: "Now is the time to begin railway and tramway enterprises. Prices are at lowest ebb."

DANIEL DWYER, of San Francisco, intervenes in the suit of the California Title Insurance & Trust Company foreclosing a million dollar mortgage. This opens the way for a number of other suits and the foreclosure will not go by default as was expected.

THE item relative to Toledo, O., street railway tracks, in the February issue of the REVIEW, was incorrect. David Robinson, of the Robinson Street Railway Company, corrects it as follows: Toledo Consolidated, 60 miles, Robinson lines (the Toledo Electric) 30 miles, all of which are electrically equipped.

THE newly equipped line on Eighth street, Cincinnati, celebrated its opening on February 28, by giving all its Price Hill patrons a free ride. President John Kilgour was master of ceremonies and a distinguished party took the trip. Among those present were D. W. Pugh of the Stephenson Car Company, of New York; E. H. Davis, of the Barney & Smith Company, of Dayton, and George Bullock, director of the Cincinnati Street Railway. The new cars, of which there are five, were made by the Barney & Smith Company.

SEVERAL unusually active and vociferous kickers, in New York City, have been writing "pro bono publico" letters to the papers, complaining of the wet and disagreeable conductors who must needs go through the cars collecting fares. "A Conductor" gives the following suggestion for a remedy:

"Let the conductor stand, or if he prefers it, sit in a nice easy chair on the tail end. Let each passenger have the exact fare ready (no pennies) when he or she steps on a car, hand it to the poor, tired conductor, resting or sleeping in his chair, ring up one fare themselves (no more) on the indicator, and when they wish to alight, step to the front of the car, draw the driver's attention by tapping on the glass of the front door that they are ready to get off; go to the rear end, each one to hand the conductor a bad cigar from men, a lock of hair or a false tooth from women, as a souvenir; step off and go home perfectly satisfied that everything is as it should be and the conductor is doing his full duty."

THE first summer car in this latitude made its appearance at Decatur, Ill., March 2. The local paper said it was a reminder of straw hats and summer underwear.

It isn't every town that has the electric railway controversy as badly as Hartford, Conn. A rival town, already blessed with the trolley, says: "Hartford has trolley for breakfast, trolley for dinner, trolley for supper and trolley for lunches, but nary a trolley for business."

PROFESSOR W. A. VALLO, of Philadelphia, has invented a compressed air street car motor. Each car is to be self contained and the exhaust air will be used to blow away the snow in winter and cool the car in summer, as well as brake the train. Signor Vallo is a music teacher and we fear it has gone to his head.

## A GRAPHIC METHOD OF SUPERINTENDENCY.

The Scheme of a Bright Manager to Encourage Competition Among Employees.—How it is Done.—The Results Attained.

The superintendent of one of the largest and best equipped street railway systems in the world has been using for years a graphic method of showing the daily expenses in certain departments. For the first time is now made public the results of his experience and an explanation of his plan.

"I find," said the manager, to the REVIEW representative, "that the surest road to success is the confidence and cooperation of the departments under me. To gain the support of the foremen and barn bosses and interest them in the economy of street railway work, means the lessening of expenses everywhere. What competition is to the life of trade a generous rivalry is to the success of the management of men. Hence my plan. Graphics have been used for many years to show plainly and

barn may be seen at a glance, but each year's record for each barn may be ascertained as easily.

For instance, in the excerpt of the chart given, barn "A" for 1893 shows barn labor per horse per day in January as  $19\frac{19}{100}$  cents, decreasing in February to  $17\frac{65}{100}$  cents, and reaching its minimum in September at  $15\frac{91}{100}$  cents. In 1894 another line will start out from the proper ordinate and follow or digress from 1893's record. Barn foreman "C" had a January record of  $17\frac{13}{100}$  cents with a July maximum of  $18\frac{50}{100}$  cents and a June minimum of  $16\frac{04}{100}$  cents. The boss at barn "B" held the straightest line with  $18\frac{64}{100}$  cents in January neither remarkably making it greater or less. His average was  $17\frac{56}{100}$  cents.

"The men," said the superintendent, "spend hours studying this pictured record, discussing this and that point of economy, planning to lessen the expense in this or that direction, and fully determined to bring out a better record next month. The consequence is that sick horses are carefully nursed back to health; old horses are disposed of to the best advantage possible; no oil or harness is misused or wasted; six men are not put on a

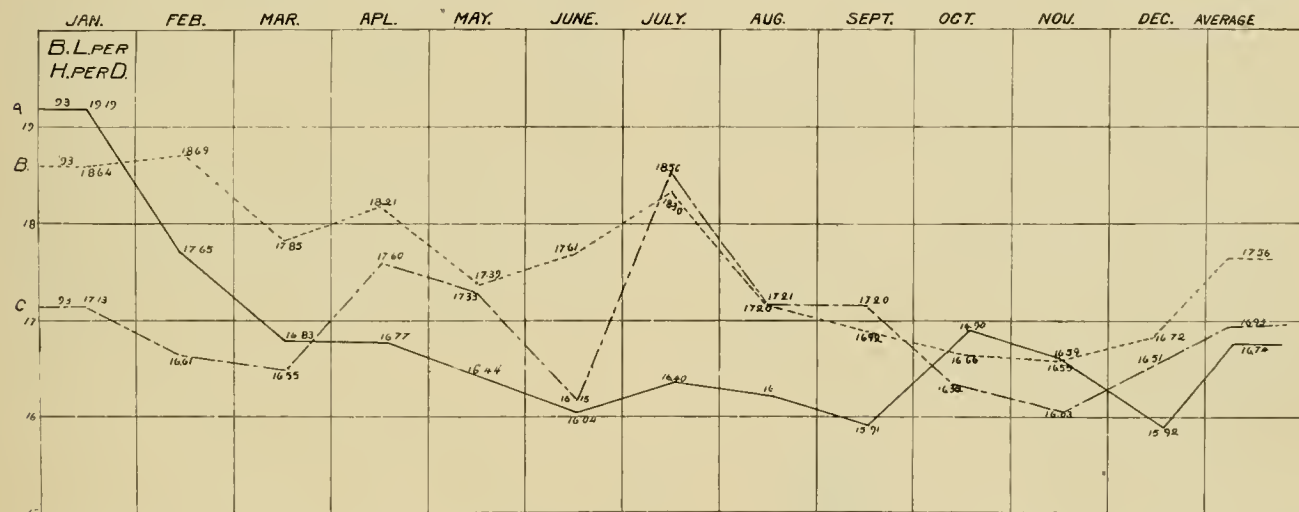

promptly the fluctuations of the grain market, the thermometer and what not. Why not for street railway economics?"

For each department the superintendent drafts a chart to cover the twelve months of the year, with space for the averages and the scale or data. The two excerpts from the charts given in this article represent graphically barn labor per horse per day in Number 1, and the total cost per horse per day in Number 2.

In Number 1, the chart is divided into the necessary sections to represent the possible minimum and possible maximum cost per horse per day for barn labor in cents, running from 15 to 20, each section being further subdivided for 10 mils. The barns are properly denoted and a scheme of colored and varied lines correspond with each barn. As each month, the report of the cost per horse per day as ascertained, the line is properly extended to represent the rise or fall in the cost of barn labor per horse per day. Each year's record is properly labeled so that not only the difference in the expenses of each

sweeper when five can possibly fight the storm, and better judgment is exercised in every detail of management."

The positions for the following year are scaled impartially on the record. The man who can save the company money, knows by his record whether he will have a more lucrative position next year, and the careless, improvident or incompetent man reads his future in the stars more successfully than any clairvoyant can tell him.

For the general weal, chart number 2 shows T. C. per H. per D. (total cost per horse per day). It is divided similarly to the first mentioned, but giving a different scale, and showing the year's instead of the barn's record. Thus, in 1893, the January total cost per horse per day was  $48\frac{265}{1000}$  cents, with a maximum in April of  $67\frac{013}{1000}$  cents and a minimum in September of  $48\frac{115}{1000}$  cents, averaging  $55\frac{990}{1000}$  cents. In 1892, starting at  $54\frac{403}{1000}$  cents, the cost ranged from  $63\frac{519}{1000}$  in September, to  $47\frac{004}{1000}$  in December, averaging  $57\frac{936}{1000}$  cents for the year.

The machine shop departments are also thus tabulated

and described. The pay roll is pictured upon another chart, and other traction than horse is shown forth.

The superintendent benefits from all the tables, and each department by its previous record, its neighbor's record, and itself.

The labor of a draughtsman a few hours each month suffices to put the records in trim for inspection, and corrections are closely watched for and carefully inspected by the men. In making the chart the several lines, or divisions of departments are indicated by different colors, which we have not been able to reproduce, and instead have used black and dotted lines for the same purpose.

### THE CAR RECORD.

Besides these details, the superintendent can by reference to another expense-saving device, determine the exact state of his car equipment. The scheme is similar to the steam road method, but will bear description and study. It is this: A frame of suitable size is divided into compartments representing each separate line of the system. Each compartment is subdivided longitudinally into sections with strips or slats like small shelves. These shelves hold small blocks, about half an inch square, which stand for the individual cars. On each of these blocks is pasted the skeleton representation of a car, as shown in figure 3. And there is your car remaining only to be further described by certain arbitrary signs as may suit the superintendent's fancy.

The skeleton car plans are printed on variously bright colored paper, corresponding with its own established

No cut corners, a 21 foot car.

A single motor equipment shows one incision in the bottom of the block. Two motors, two incisions.

Proper drawings upon the face of the card also completely describes every car in service—its number, line,

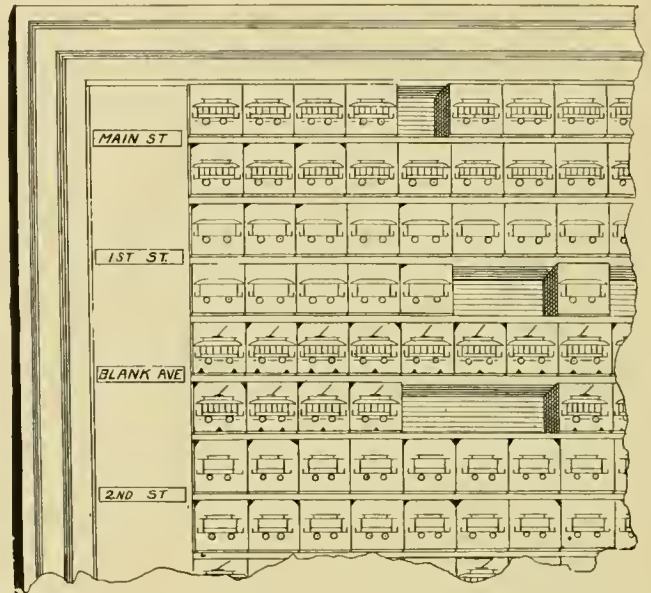

equipment and place, whether in the shops, on the proper line, lent, sold, borrowed or destroyed.

The case is divided laterally into sections of ten blocks each for convenience in counting up the hundreds of cars in use. The services of a man a few hours a month is

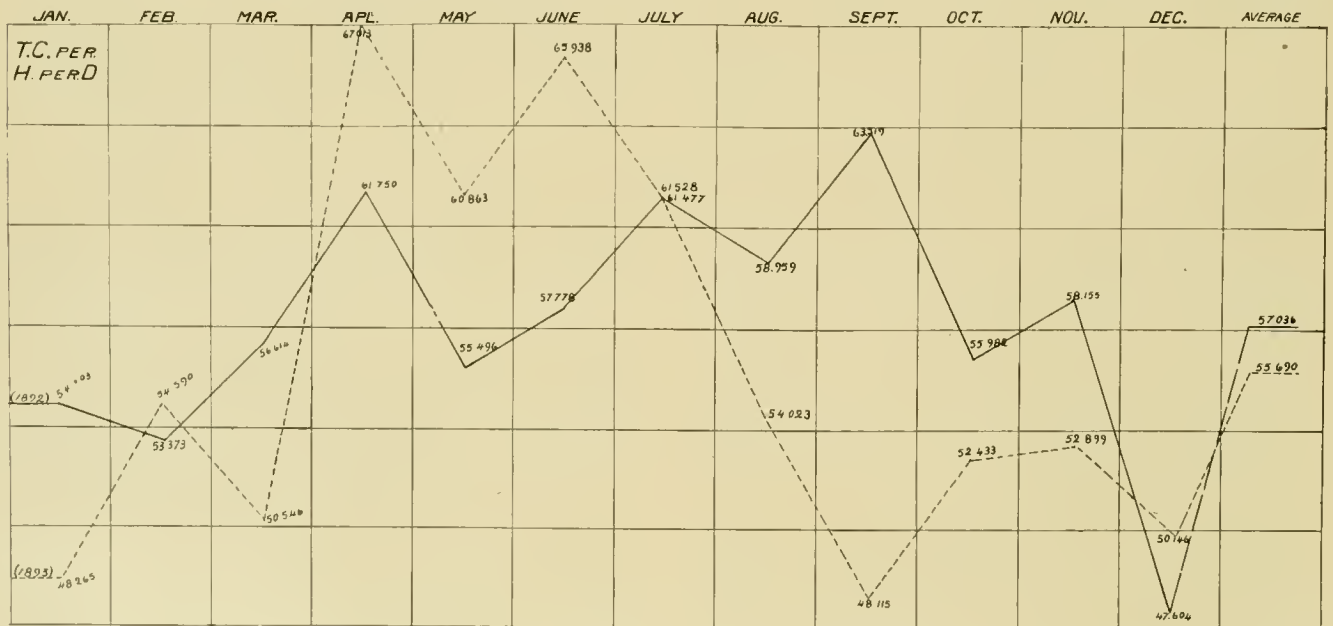

color of the line to which the car belongs. For instance: First street cars (blue line) are on blue paper, the Main street line rejoices in its brilliant red, and the Blank avenue shows plainly in yellow.

Some of the signs used by the superintendent are:

One cut corner 16 foot car.

Two cut corners, a 14 foot car.

sufficient to keep this simple system in operation. It dispenses with the services of bookkeeper and is much more convenient.

MIXING MORTAR by means of power supplied from the trolley circuit is said to be a feature of Great Falls (Mont.), building.



THE BEGINNING OF TRAMWAYS IN LONDON.



THE BEGINNING of the large and powerful, if not progressive London General Omnibus Company, was in the brain of an Italian, Count Orsi, then, in 1855, residing at Paris. Following out the idea the Count attempted to raise the capital from wealthy Londoners and French bankers. Failing in this, he went back to Paris, incorporated his company, fixed the capital at \$4,000,000 in \$20 shares and proceeded to sell to small investors. The Parisian and London press began with unanimity to deprecate the scheme and prophesy the failure of the small investors.

But the money was subscribed.

Coming back to London with \$4,000,000, the Count was no more to be deemed a visionary. The leaders took up his cause. Five Englishmen and three Frenchmen were made directors, and one day in 1856 five hundred and twenty-five busses were put to work in the Metropolis. Two thousand five hundred are now in operation, and the Count Orsi, still hale and hearty at the age of eighty-three, watches his venture with interest.

A peculiar ceremony of transfer at the time that the English directory entered into management may bear repetition. The French directory were ranged on one side of the room and the English on the other, a la Rugby, but seated and eight feet apart. A chair was placed in the middle to represent the undertaking. There the Count solemnly transferred the chair to the English side, typifying the transfer.

DUBLIN'S DOINGS.

The twenty-sixth semi-annual meeting of the Dublin, Ireland, United Tramways Company, was held January 16. The report was highly satisfactory to the stockholders as a five per cent dividend was declared, free of income tax, besides a comfortable sum added to the sinking fund. The system is worked by horses of which there are 1,203. The number of cars was 156. The car mileage for the half year was 1,208,035; track operated, 33 miles; parcels delivered, 169,250; accident compensation, \$105 for the half year.

The accounts for the half year give the following showing: running expenses (provender, repairs, wages, etc.), \$178,645; traffic receipts, \$329,990; total working expenses, \$225,485; total income, \$349,110; balance to net revenue, \$88,770.

The parcel delivery at all times of the day and not at stated intervals, cost \$5,945 and paid \$8,015; mail brought in \$155, expense nothing extra. Both these subsidiary methods of increasing income have been described in the REVIEW. Nearly \$50,000 was spent in repairs of road bed and reconstruction. R. S. Tresilian is assistant secretary, whom we thank for report and congratulate upon the brilliant record of this Irish road.

AN ALDERMANIC MEASURE.

The bright secretary and treasurer of the Houston, Tex., City Railway Company, C. A. McKinney, sends us the following copy of a resolution adopted by the San Antonio, Tex., city council, relative to the 38-girder rail in use on certain streets of that city. The resolution is printed as follows:

Whereas, cars of the San Antonio Street Railway Company have frequently left the track on South Alamo street between East Commerce and Goliad streets, running with terrible speed and force onto sidewalks and even into fences, walls, etc., to the great danger of all traffic on said street as well as the passengers on board the cars; and,

Whereas, Said track is laid with flat rails which were once suitable and in use during the days when cars were moved by mule power but which are now too light and in other points inadequate for the heavy electric cars now being used; and,

Whereas, For the reasons above stated said portion of track on South Alamo street is a most dangerous nuisance; now, therefore, be it

Resolved, That the mayor notify President Weiss, of the San Antonio Street Railway Company, to immediately substitute T rails for said flat rails within thirty days from this date, with notice that if the change is not made in the time specified the city will condemn said portion of track and by ordinance abrogate the company's franchise to said portion of South Alamo street. Also that cars be limited to one mile an hour on said track until the T rail is substituted, and that the city attorney be instructed to draw up an ordinance to regulate the speed of cars on said track until the T rail is substituted.

This action will be noted with interest by those who wish to substitute T rail or wish to lay T rail for new lines.

DEATH OF HIRAM R. RHOADS.

Hiram R. Rhoads, president of the Pennsylvania Street Railway Association and of the Williamsport, Pennsylvania, Street Railway Company, died February 17 at his home in Williamsport, at the age of 49, of heart failure.

Mr. Rhoads was born in Philadelphia, in 1845, and began his railroad career at the age of 18 as a telegraph operator with the Pennsylvania Railroad Company, rising to division chieftainship. Going into telephone service at the beginning, he opened the second exchange in Pennsylvania and in 1880 organized a telephone supply company of which he was president.

In 1890 he purchased the Williamsport Street Railway Property and later became interested in the Lycoming electric light and the Norris-town Street Railway Companies. His election to the presidency of the state association was a deserved honor to his integrity and ability as an organizer and his executive skill. The entire fraternity mourns his loss.

OF the 1,720 electrical patents issued in 1893, says the World, 213 were in the traction field, of which 84 were systems and conduits, and 25 electric locomotive devices. Electric welding claims 18 plans, while trolley specialties head the list with 104 individual inventions.



THE LATE H. R. RHOADS.

## LONG DISTANCE TRANSMISSION BY CONTINUOUS CURRENTS.

By F. Boissonnas of the Cie de l'Industrie Electrique, Geneva.

The extraordinary fancy shown lately by most electrical people in favor of multiphase working for long distance transmission, and in general for all kinds of work, is not justified by the practical results achieved, and we will endeavor to show why we do not believe in the successful future of multiphase currents transmission or distribution. It must be well borne in mind that we do not reject absolutely multiphase current, and in some cases we may even find advantages in their adoption, but we want to declare against the opinion that they are the universal panacea for long distance transmission and distribution.

It is only since the Frankfort exhibition, less than three years ago, that multiphase currents have made a practical entrance into the electrical world. They were previously well known to electricians, principally from the experiments of Ferraris, Tesla and Thomson, but their coming on the stage of large experimentation announced as a practical achievement, was engineered with such skill that the effect produced was enormous, when the practical results were at least questionable. What were the advantages claimed for multiphase currents? They were numerous; at least two of those stood in front well ahead of the others. First of all, the ease with which all alternate currents are transformed from low into high tension or from high into low tension, and next, the simplicity of construction of motors, and their starting even when loaded. If we consider the first advantage, which is a real one, we see it is yet limited by practical considerations. Let us suppose we have to transmit a very large power at a very great distance. If we want to do it economically, we have to use an enormous voltage, to reduce the cost of mains. Now, how do we get that enormous voltage? Nothing is more easy, as it seems. We have the transformer at hand, and we will transform at 50,000 or 100,000 volts. That is certainly very nice when speaking of it, but when we come to design transformers to stand this enormous tension, we have to face difficulties such that we are obliged to come to lower tensions. It is splendid to design transformers for 100,000 volts, but it is still more splendid to see these transformers at work. We mean transformers for industrial purposes, carrying a certain number of amperes, and not experimental transformers for some hundredths of amperes.

We think we are right in asserting that no commercial transformer has been constructed for working steadily at pressures over 20,000 volts, and there are not more than two installations utilizing this voltage. They have been in working order only since a few months, not a period sufficiently long to form a definite opinion on their qualities. But we contend that, in the cases where they have been adopted, continuous currents would have filled their place with equal, if not better results. The multiphase

current motor has over its continuous current rival the advantage of dispensing with commutator and brushes. That is a great point in mining work where you have to take sparking into consideration, but we must remark that in modern continuous current motors, the running can be considered as sparkless even under varying loads, and that by the use of carbon brushes, the tear and wear on the commutator may be neglected. We are well aware of the advantages of easy transformation and of suppression of sparking, but in most cases these advantages are overrated and cannot compete with the inconvenience derived from the system itself. We all know that in practice, either with tri- or biphased currents, if one conductor is used as common return for several circuits, that which is the most economical and less complicated arrangement, the circuits utilizing this common return come more or less in interference one with the other, with the result that if the currents passing in these circuits are different in intensity they induce variations in the voltage, variations which may reach as much as 30 per cent in practice. Thus is lost the quality of multiphase currents to supply light and power with the same mains.

In multiphase current working we have an important question, as to the best frequency. Is it better to work at low or high frequency? The question is twofold. If we consider the cost and efficiency of transformers, high frequency is to be preferred, and it seems also better for connecting alternators in parallel, if we consider practical results. But on the other hand, low frequency is better for motors, as it enables getting very low speeds without multiplying the number of poles. You are obliged to sacrifice either the transformers or the motors, as taking the average does not give good results. By using multiphase currents, you prohibit the use of concentric cables, on account of their capacity effects. You cannot always adjust your load so that the capacity just balances the lag in the current, (that is to say, the self-induction) and the connection or disconnection of parts of cables by the starting or the stopping of a motor, induces pressure effects, enormous as to the rise of voltage they originate; this voltage being possibly many times the working voltage, with the result that no insulation will be capable to withstand the enormous strain put upon it. Many devices have been brought out, it is true, for attenuating these pressure effects, but they are more or less complicated, rather more than less, and people do not want complications which they may dispense with. If pressure effects are originated in concentric cables carrying multiphase currents, induction effects are set up in parallel cables carrying these currents, which means loss of power and trouble in the distribution.

Another complication people do not want is in the number of conductors. In multiphase working, the bet-

LONG DISTANCE TRANSMISSION BY CONTINUOUS CURRENTS.

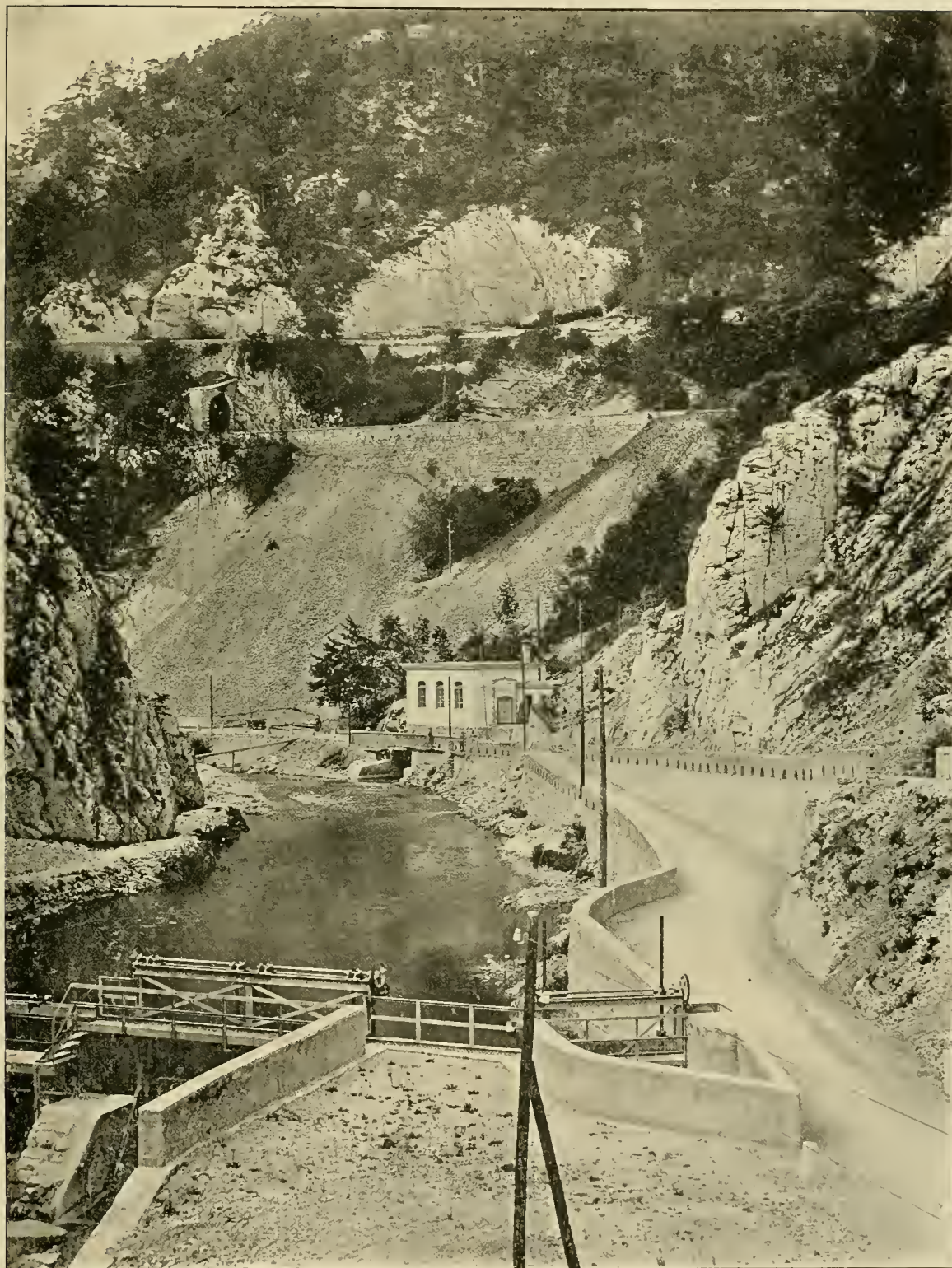

PACCINOTTI WATER POWER STATION NEAR GENOA, ITALY.

ter results are achieved with four conductors; but who will want four wires if he knows he can do as well with two, or still better with one? Another very important question is that of efficiency. Users have to pay for the whole current entering their premises, and if they have a transformer, they have to pay for the current wasted in the transformer. Moreover, in long distance transmission by multiphase currents, we have to take into account the losses in the generator, a step up transformer, the line, a step down transformer, and the motor, supposing each motor to be supplied by its own transformer. If we may dispense with transformers, we have a clear profit, not only on the working, but even on the prime cost, since owing to the increased efficiency, when leaving out trans-

series, and an able professor has gone so far in this way as to say that this coupling was impossible, since to connect a new machine, the load increasing, it was necessary to break the circuit. He did not, evidently, think that by short circuiting permanently the machines when at rest, there was no necessity of breaking the circuit to connect a new unit.

High tension closed coil continuous current machines have not come into general use on account of the difficulties encountered by makers with the commutators. We claim to have arrived at such results in that way as to be able to guarantee absolutely the good working of 3,000 volt dynamos, even if working day and night continuously for months.

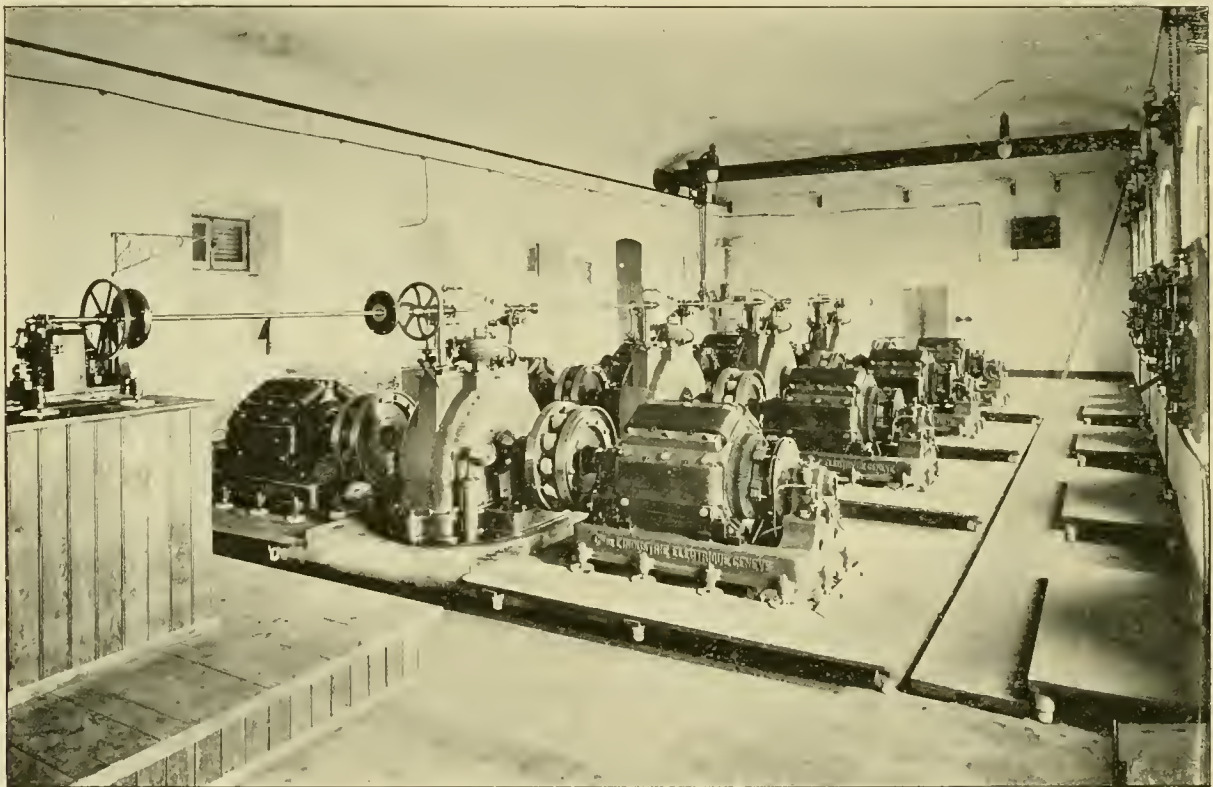

INTERIOR PACINOTTI WATER POWER STATION.

formers, the plant to be erected for transmitting a given amount of energy may be considerably less, and consequently cheaper. With very high tensions, each transformer is a weak point, facilitating a break down. The system we propose and advocate below, is not considered by ourselves as an universal panacea, but as an excellent specific in many cases, principally for long distance transmissions and distributions.

What is the greatest grievance against continuous currents? People pretend its use to be incompatible with high tensions. That is wrong altogether. If we have batteries, and if we want a high tension, we connect in series as many cells as are necessary to get this tension. Why not to do the same thing with dynamos? There is a very strong prejudice felt against coupling dynamos in

With 3,000 volt units it is not difficult even with a limited number of units to reach very high voltages. With six units only we arrive at 18,000 volts, and nothing prohibits going much higher. This arrangement is possible only for a certain power to be transmitted, as you cannot make 3,000 volt machines for a few horse-power only. The system may seem complicated at first sight, on account of the number of units necessary, but, if we consider the results achieved both as to efficiency and simplicity of working, we see that this complication is more apparent than real. For efficiency an example will show it better.

Suppose we have to deliver current to a motor and must be able to get 1,000 horse-power out of the shaft of the motor, and this current is to be transmitted from a

generating station utilizing water-power. Let us see if it is more advantageous to use multiphase or continuous currents for this transmission.

Starting with the first-named, the efficiency of the motors of large power, either continuous or multiphased, may be taken as 92 per cent, the efficiency of transformers 95 per cent, that of the line in both cases 90 per cent, and that of the generators also 92 per cent. So the horse-power required from the turbines will be in the case of multiphase currents  $1,000 \div (0.92 \times 0.95 \times 0.90 \times 0.95 \times 0.92) = 1,454$  horse-power.

With continuous currents and a transmission in series,

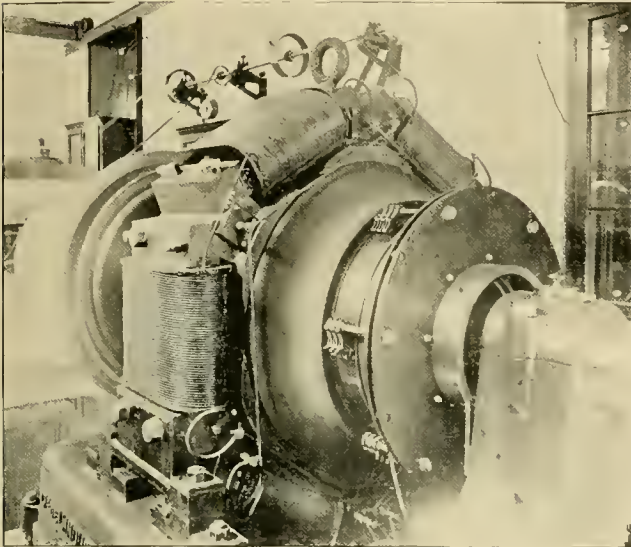

1300-VOLT GENERATOR, PACCINATTI STATION.

allowing us to reach the same voltage as with multiphase currents, the efficiency is the same for motor, line and generator, but we dispense with transformers, so that in this case, the energy required from the prime mover comes to

$$1000 \div (0.92 \times 0.90 \times 0.92) = 1,312 \text{ horse-power.}$$

So we realize a saving of 140 horse-power and the working is much simpler.

#### SOME PRACTICAL EXAMPLES.

After a perusal of the above, it will be interesting to investigate the manner in which this company has demonstrated their theory as to direct current transmission.

On the side of the mountain, opposite Genoa, is an available waterfall of nearly 1,200 feet. This is utilized by three stations, one above the other, the object being to obviate using such enormous pressure with the turbines. Evidently Pelton wheels are not common in that region. The power transmitted from these stations is about 1,000 horse-power. The highest is known as the Galvani station, the intermediate the Volta, and the lowest the Paccinotti. Our engravings are of the Paccinotti, which is a fair example, and will be described briefly. These are four 140-horse-power turbines, each connected by insulated couplings with two series wound dynamos, giving a constant current of 45 amperes. The maximum voltage of each machine is about 1,000. The dynamos

are all run in series, so that the station voltage at full load is 8,000. The turbine speed is regulated by the current, by means of a differentially wound motor, which opens and closes the turbine valves. However, the peculiarity of the series dynamo nearly makes such regulating apparatus unnecessary, as, no matter what the load, these dynamos require a constant torque, and this is just what the turbine tends to keep. The dynamos and surrounding platforms are very carefully insulated, as will be noticed.

The power is transmitted about twenty-five miles, and utilized by motors of from 3 to 60-horse-power. The system is best adapted to the use of large motors, and hence to the replacing of engines in street railway plants, which is about the only way in which power transmitted from a long distance can be utilized by street railways in the present state of the art. Since completing the Genoa stations, the Cie de l'Industrie Electrique has put in another plant for transmitting power to a station eighteen miles distant. In this, two 3,000-volt generators are connected electrically in series, making the line voltage 6,000 to 6,500. The two motors, which are used to run a paper mill are also connected in series.

#### THE ONE THING NEEDFUL.

The public-spirited citizen sat down with a grunt in the street car and glanced about for an audience.

"These stuffy cars are regular disease breeders," he said to a short, fat, bland and meek party by his side, in a voice that could be heard in the car that was following.

"So?" queried the meek man.

"Yes; and it is an infamous outrage that the poor laboring man has to pay five cents for a ride when four of those cents go into the monopolist's pocket."

"Don't say?"

"Yes; and you can't beat them with a rival company, for they'll buy up the courts, they'll buy up the courts."

"Is it possible?"

"Yes, and—"

"Hold on," said the meek man, as the conductor came in to see what the noise was about. "Haven't you forgotten one more thing that ought to be done?"

"What's that?" asked the loud man, with a don't-interrupt-me-inflection.

"Don't you think," said the meek man, very slowly, "that they ought to provide inside platforms for public speakers?"

#### NEW PAVEMENT AT MUNICH.

A pavement has been tried in Munich for about two years, which consists of blocks made from serpentine rock ground up, treated in a solution, and pressed into shape by hydraulic power. The blocks are 10.8 by 4.4 by 6 inches and 7 by 4.4 by 6 inches. The manufacture is carried on by a German firm. The blocks are peculiar, in that while very tough they are not brittle, and powerful blows make an impression on the stone but do not break or splinter it.

### AN ELECTRIC FREIGHT LINE.

An interesting experiment is said to about to be made on the Delaware River and Lancaster Railroad in Chester County, Pennsylvania, looking toward the equipment of this erstwhile steam line with electricity. The road is eleven miles long and has been built four years but abandoned after two trials, one as an independent line and one as a leased part of the Wilmington and Northern.

Col. Du Pont of Philadelphia, president of the original Company, is now planning to resume independent operation, using electricity instead of steam power and hauling freight exclusively. A fall on the French Creek is thought to be sufficient for water power.

Valuable quarries will furnish the traffic and freight.

### THE STREET CAR SPITTER.

At present, Minneapolis has given over every other interesting topic to discuss the abomination of tobacco chewing and spitting on the street cars. The medical faculty has been invoked to give long columns of physiological and bacteriological reasons why the spitter must go. Ladies by dozens besiege the general manager and the mayor, asking for relief. The city council will probably have a proposition submitted to abate the evil. Ad interim the car cleaner waiteth and trembleth, between hope and fear, and the spitter eke wondereth if the succulent "plug" will be relegated to the front platform and the aristocratic fine cut shall be banished from its morning ride.

### GETTYSBURG BATTLE-FIELD ROAD RECEIVER.

The Maryland Steel Company and the Brill Car Company, file bill in equity, asking that a receiver be appointed for the Gettysburg battle field railway and that the management be restrained from selling the property. The bill charges mismanagement on the part of the management and that \$11,000 are owed the complainants. Judge McClean allowed preliminary injunction.

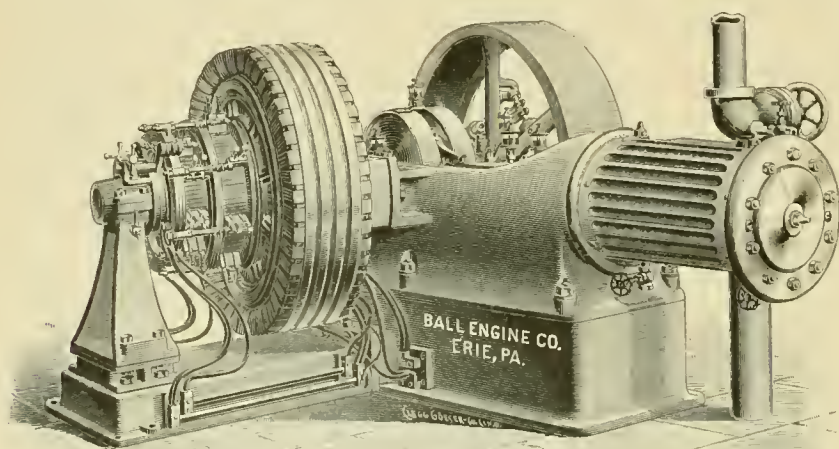

### THE SEVEN STAGES OF A STREET RAILWAY.

- I. At first the incorporators  
Striving and pushing for a chartered right  
To enforce the doctrine 'right means might.'
- II. Then the wealthy syndicate,  
With their glowing bits of fact and fancy,  
Sounding like tales of necromancy.
- III. And then the bankers  
Seeking to sell the bonds, solid as rock,  
Keeping themselves the freely-watered stock,  
This for the lambs—investment good as gold—  
A brand new lamp, better than those of old.
- IV. Then the car trusts,  
Mortgages on wheels  
Foreclosed so readily without appeals.
- V. And then the receivers,  
No coupons now to pay,  
All debts deferred until some other day,  
A voting trust protecting all the stock  
That grewsome bears are sure to try to knock.
- VI. The sixth stage shifts  
Into the reorganization plan,  
Where all the wreckers join in one great band  
Where innocent experience dearly bought  
Is daily learned by some—by others taught.
- VII. The last scene of all in this eventful mystery,  
Two streaks of rust—a mortgage and—a history.

*Mount Holly Herald.*

### THE BALL DIRECT CONNECTED ENGINE.

Engine builders have of late been rapidly adapting their engines to direct connection with various types of dynamos, and the direct connected form is coming extensively into use, especially where space is valuable. The Ball Engine Company, of Erie, Pa., have made a number of installations in connection with various types of dynamos. Among recent ones, are two 200-horse-power cross-compounds, directly connected to Siemens & Halske dynamos, for the Lumber Exchange Building, Minneapolis, Minn., one 125-horse-power simple engine, connected to a Waddell-Entz dynamo, in the store of Willoughby, Hill & Co., Chicago, one 80-horse-power engine in connection with a Waddell-Entz dynamo, in the building of Cumner Craig & Co., Boston, Mass. The accompanying engraving is of the 80-horse-power engine and Waddell-Entz dynamo. The armature is keyed to the engine crank shaft. This shaft is supported at the end by an outboard bearing, resting on an extended sub-base. The distinctive features of this well-known engine are beauty of design, simplicity and compactness, solidity of frame, large bearings and excellence of materials and workmanship. The massiveness of the Ball engine makes it well adapted to varying loads. The regulation is within one per cent. Every detail of construction receives the most careful inspection and every engine is thoroughly tested before shipment is made.

**PNEUMATIC QUICK BREAK SWITCH.**

The Ohio Brass Company, of Mansfield, Ohio, manufacture a quick break switch which introduces a pneumatic blow out. The engraving shows the switch closed. The handle has a toothed segment near its base. This segment meshes in a rack operating the plunger rod in the cylinder. When the handle is drawn down the plunger is drawn out of the cylinder and a spring in the cylinder is compressed. When the handle has been drawn down to a certain point the small projecting pieces strike the body of the switch and the contact lips are separated. As soon as this is done the compressed spring in the cylinder draws the arm up to make a quick

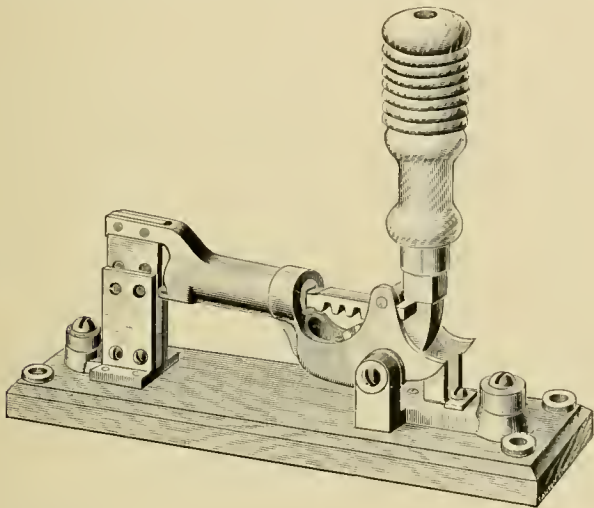

wide break, while the movement of the plunger forces a jet of air against the arc. The switch is of polished brass on a slate base, and is made single, double and triple pole from 100 amperes upward. It is a very ingenious and at the same time simple device and certainly has a place on the switchboard.

**MELBOURNE'S MUTUAL BENEFIT ASSOCIATION.**

A strongly organized and splendidly conducted Mutual Benefit Society has been doing its good and beneficent work among the employes of the Melbourne Tramways Company, since 1888.

Its benefits are classed thus:

- I. Relief of members in case of sickness or accident.
- II. Defraying funeral expenses of members or members' wives.
- III. Providing medical attendance for members, their wives, and children under sixteen years of age.

The membership is composed of employes in any capacity, of the Melbourne Tramways & Omnibus Company, Limited, not a contractor for the company or an employe of a contractor, of good moral character, between the ages of 16 and 45, not a member of any trade union wholly or in part composed of employes of the company, and who passes the physical examination and pays the dues.

Entrance fees are charged. From the ages of 16 to 35, sixty-two cents; from 35 to 45, \$3.75. Each member pays a weekly subscription of twenty-five cents in advance, provided that any gifts received from the company or any other source shall be applied to lighten this tax, until it shall be reduced to twelve cents per week.

Honorary members may pay annual subscription of \$25.00. The funds are distributed between the two general purposes, namely: The sick and funeral fund and the medical and management fund.

The society is governed by a managing committee, representative of the classes of labor employed, as follows:

- 1 gripman and 1 conductor from each line of cable.
- 1 driver from each horse car or omnibus line, provided the maximum number of cars or busses be not less than five.
- 2 men inside car barns.
- 2 men inside engine house.
- 2 men inside stables and buss barns.
- 2 from miscellaneous employes, clerks, etc.

The committee must have at least twenty and not more than thirty-one members.

The benefits are on a sliding scale. Every member who shall have been in good standing six months and incapacitated by sickness or accident, may draw \$5.00 a week not longer than six months. Members of nine months' standing may draw the same amount for six months, half the amount for three months more, and \$1.25 a week for three months longer. A six-months member's next of kin receives \$50 and a nine-months member's \$100 in case of member's death.

In case of death of a member's wife, or widowed mother supported by such member, the member receives \$25 if of six months' standing, and \$50 if of nine months' standing. Every member shall be entitled to receive free medical attendance for himself, his wife, his children under sixteen, and for a widowed mother or her children under sixteen, if supported by the member.

These benefits are protected from misuse by certain regulations relative to drunkenness, immorality, bravado and fraud.

A series of blanks is in vogue, of which we reproduce three.

DOCTOR'S CERTIFICATE ON FUNDS.

I certify that..... is afflicted with or suffering from..... and is not able to follow his usual employment of..... Society Doctor.

DOCTOR'S CERTIFICATE OFF FUNDS.

I certify that..... is sufficiently recovered to be able resume his usual work as..... and is not entitled to further sick allowance. Medical Officer.

MEDICAL CLAIM FOR FUNERAL ALLOWANCE.

I certify that....., aged..... years, late of....., died on the..... day of....., 18.., and I consider his (or her) death to have been caused by..... (or the verdict was.....) Dated..... day of....., 18.. Medical Officer.

The society is under supervision of the provincial government, and has been of the greatest and most praiseworthy service to the employes and their families.

## T RAIL IN SAN FRANCISCO.

The Southern Pacific Railroad at its street crossings in San Francisco uses a small T rail as a flange, in the manner shown in the accompanying illustration. The paving is then laid against the flat bottom of the set-in rail. It has the advantage of not requiring any form of rail not commonly in use on the road. We are indebted to W. A. Underhill, of San Francisco, for these interesting particulars.

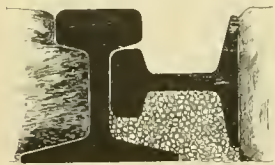

## PREECE ON AMERICAN ELECTRIC RAILWAYS.

The eminent English electrician, W. H. Preece, ex-president of the Institution of Electrical Engineers, has been favoring that body with some notes taken on his trip to the United States last summer. He concluded his paper with a few remarks on electric railways, some of which will be news to Americans.

Thus, for example, it is generally known that broken insulators are more common with bracket than with span wire construction, but a very different impression of the status of center pole construction is given by Mr. Preece, who says: "Attempts have been made to improve the appearance of the road, by using handsome central iron poles, with solid brackets on each side, to carry the two trolley wires, but the want of elasticity has introduced fresh evils. The trolley frequently comes off and great sparking is evident." It is also indeed "astonishing that the American community submit" to the trolley, when it is the only practical solution of the rapid transit problem in 99 out of 100 cases. The Chicago North Shore Electric Railway is briefly described, and in general favorably criticised. He says, however:—"The feeders are carried on wooden poles, which are very unsightly. These feeders could have been more economically and more efficiently put under ground." If Mr. Preece had not been able to figure out simple problems in arithmetic better than that in times past he would never have attained his present standing. What a foolish thing it was for the North Shore company to sink so much money running feeders on neat pole lines over the prairie and down the back alleys of suburban villages, when those feeders could have been more economically and efficiently put underground. We are afraid, however, that the interest on six or seven miles of underground wiring would make a big hole in the receipts of a suburban road. Mr. Preece has learned that the average mileage of a car in full service is 250 miles a day, and its mean speed fifteen miles an hour. This will make those superintendents who thought their cars were making a good record at 150 miles a day and a maximum speed of fifteen miles an hour, rub their eyes and wonder if they have been asleep and have been left behind in the march of progress.

## COST PER CAR MILE AT LITTLE ROCK.

Last month mention was made of the good record of the Little Rock (Ark.) street railway system.

Through the kindness of Consulting Engineer B. J. Arnold we are enabled to give this month, in its entirety, Manager H. G. Flemings' excellent record.

As to fuel, coal is used at \$1.25 a ton. Lima oil can be delivered on side track at  $3\frac{5}{100}$  cents a gallon, thus being unable to compete with coal.

The gross earnings of the system for the year ending December 31, 1893, were \$101,460.03, the operating expenses were, not including insurance and taxes, \$62,828; net earnings, not including insurance and taxes, \$38,636; per cent of expenses to earnings,  $61\frac{9}{10}$ ; insurance, \$1,600; taxes, \$3,503.

The car mileage was 714,228; total expenses per car mile,  $8\frac{8}{100}$  cents, not including insurance and taxes; insurance and taxes per car mile, .7 cents. Passengers carried (numbered) 1,969,582; expense per passenger, not including insurance and taxes  $3\frac{1}{100}$  cents; line expenses, per car mile, .2 cents; track expenses, per car mile, .6 cents; expense per car mile for car cleaning, repair of cars and motors, 2.1 cents; expense per car mile for power, 1.5 cents; expense per car mile for fuel, .7 cents. The other expenses per car mile were 4.4, and the earnings per car mile, 14.2 cents; passengers carried per car mile, 2.76.

During the year not a passenger was killed and only 19 injured, or a proportion of 1 in 103,662 passengers carried. The damage claims amounted to \$275. In the statistics given are included only revenue passengers, complimentary tickets and employes riding would swell the total traffic to over 2,000,000 and reduce the per passenger percentage in proportion.

For an 18-car road in the hands of a receiver, and with 30,000 population to draw from, this record is an unusual one.

## THE MATHER ELECTRIC COMPANY.

The Mather Electric Company announces its return to manufacture and its reorganization. The official list is as follows: President, Maro S. Chapman; vice-president, T. C. Perkins; secretary and treasurer, John L. Bunce. All the officers are well known to the electrical fraternity, and are, besides, experienced in the manufacturing business.

The technical arrangements are in the hands of Theodore Gonet, with E. Powell as assistant. The company begins operation with a well equipped factory, at Manchester, Conn.

There is a good working capital, and the business will be extended as necessity requires. It is intended to manufacture a variety of electrical specialties, including large dynamos for electric light and street railway power stations.

DURING the severe snow storm of February 12, the Milwaukee Street Railway Company kept its 130 miles of track open throughout the day.



PERFORMANCE OF MODERN MOTOR EQUIPMENTS.

Electric railway motors and their attendant appliances have been in a state of constant change ever since the beginning. While the motors have been greatly improved in the way of durability the requirements have also been increased. The maximum speed now common is from 10 to 25 miles an hour, in place of 8 to 12, as formerly. It is also safe to say that quicker starts are made than a few years ago. For these reasons a scientific comparison of present equipments with previous ones is almost impossible, and perhaps even were it possible it would be useless, as no one would think of going back to the double reduction motor with its attendant repair bills even if a much higher efficiency could be shown for it.

very clearly the current consumption of modern motors pulling trailers, and the results were very gratifying, both as regards average and starting current. Almost nothing has lately been published on the power consumption of the latest types of motors when running alone. The accompanying curves have been selected as giving a good idea of the performance of modern motors under various conditions.

Figure 1, is a curve plotted from readings taken on a Sperry motor in regular service on West Twenty-second street, Chicago, by superintendent W. F. Brennan, of the Chicago General Street Railway Company, and a REVIEW representative. In this and in all the following

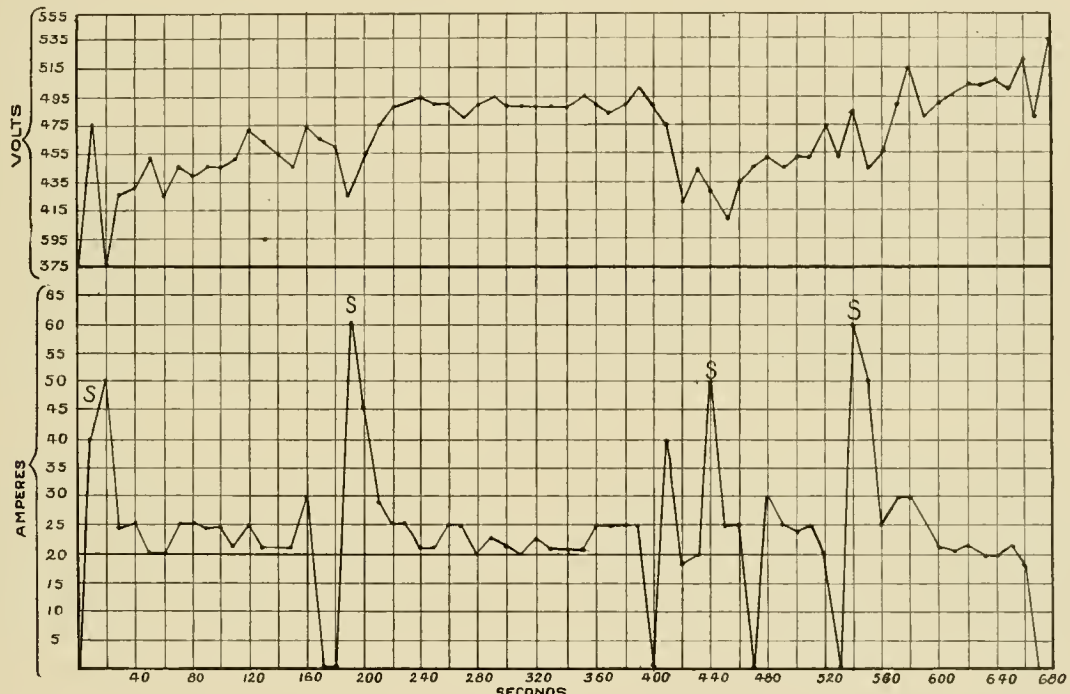

FIG. 1.

Nevertheless it is interesting to know how modern equipments really act under modern requirements, and to see what changes series-parallel control and increase of speed and weight of cars have brought about in the power consumed by a car. For any given weight of car and type of motor the initial starting current required with series-parallel control is one-half that necessary with the old style rheostat and the motors always in parallel. To partly counteract this are the heavy modern car bodies. The initial starting current must also necessarily be higher with single reduction than with double reduction motors, other conditions being equal. Increase of speed of course calls for more current and helps increase the average current required from the power station thereby, also helping to counteract the effect of series-parallel control.

The motor current curves from the Chicago City Railway, published in our November, 1893 issue, showed

curves, the time taken in waiting at railroad crossings has been left out of the account, hence the averages will be a little higher than they actually are in practice. In Figure 1, the length of trip was 9,900 feet; time, 11 minutes, 20 seconds; maximum speed of motor, on level, 12 miles per hour; average speed of trip, 10 miles per hour; average current, 24.4 amperes; track slightly greasy; line straight, and without grades; weight of car, 6 tons. Figure 2, is the return trip of Figure 1. The average current was 23.8 amperes, and the average speed, 10.1 miles an hour. The points marked S, are the starts from a dead stand-still. The readings were taken every 10 seconds. The motor is Sperry's latest type bevel geared, and flexibly suspended between the axles. The starting current is, of course, high, but still less than with many old types. The control is entirely by rheostat.

Figures 3, 4 and 5 are from the note book of G. W. Knox, electrician of the Chicago City Railway. Right

here it may not be amiss to mention the sound policy of superintendent Bowen, in keeping such close records and having such extensive tests made of everything on his electric lines. Furthermore, his willingness to give the street railway fraternity the benefit of them can not be too highly commended, and we are sure is appreciated by all.

S 10 means that the car was started from a standstill and the controller put on the tenth or highest point without pausing at the intermediate ones. It is gratifying to note the fact that it is almost impossible for a motorman to seriously abuse his car by too sudden starts. Even with a very rapid handling of the controller the current rarely exceeds 60 amperes, and with a slow start, such as is



FIG. 11.

Figure 3 is from a Westinghouse single motor equipment in regular service on Forty-seventh street. Distance, 3 miles; time, 23 minutes, 30 seconds; number of passengers, 85; weight of car, 13,680 pounds; average speed, 7.8 miles an hour; maximum speed 15 miles an hour; average current, 20.5 amperes; 15 second readings.

common on many roads, the initial starting current is even less than that required at full speed. In other words, to make a very quick start now requires no more current than was formerly required for very slow ones.

In Figure 4 the distance was 18,480 feet; time 17 minutes, 30 seconds; average speed 12 miles an hour; weight

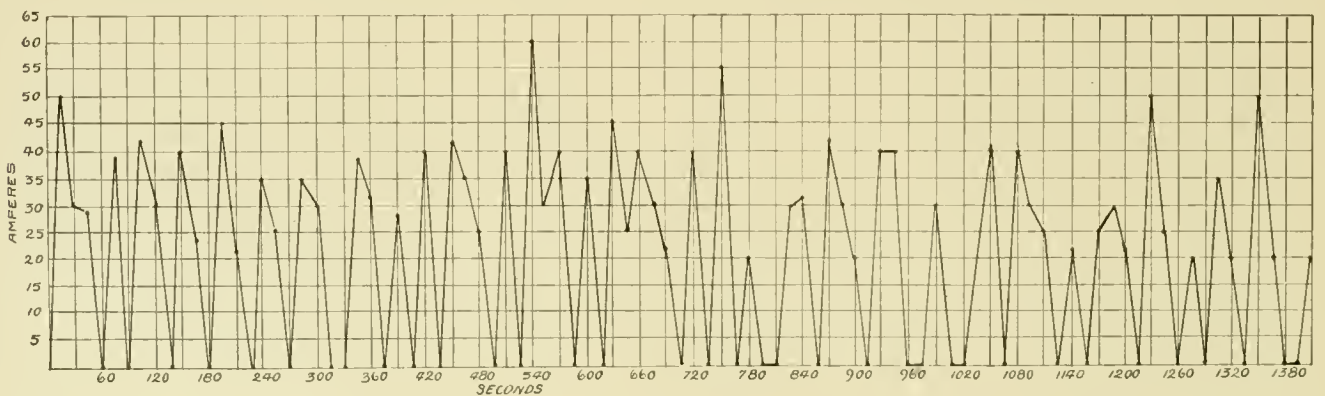

FIG. 111.

We come now to a study of series-parallel control. Figures 4 and 5 are from a Westinghouse double motor car without trailer, on Thirty-fifth street. S indicates a start from a dead stop. G is a 6 per cent grade, 1,200 feet long. M indicates maximum speed. The figures show the point which the controller handle was on. Thus

of car, 15,980 pounds; passengers, 26; average current, 29.3 amperes; track a little slippery.

Figure 5 is the return trip of Figure 4. The time was 18 minutes, 45 seconds; average speed, 10 miles an hour; average current, 18 amperes.

The following are some figures obtained by Mr. Knox

from double motors running on the various points of the Westinghouse controller. The average of readings is as follows. Four to fifteen readings were taken on each point.

	AMPERES
First point,	11.0
Second "	12.0
Third " (motors in series resistance all out)	16.7
Fourth "	19.5
Fifth "	23.1
Sixth "	24.2
Seventh "	22.1
Eighth "	29.7
Ninth "	31.6
Tenth "	34.2
First " (6 per cent grade)	20.5
Third " " "	19.0

point 10 miles per hour; second 10; third 8.5; fourth 12.2; fifth 10; sixth 12; seventh 12; eighth 17.1; ninth 17.1; tenth 15. The voltage never varies more than 10 per cent and the track was apparently all in the same condition, so that the variations both of speed and current are very hard to understand. A motor running at full speed along a level track will show variations of current amounting to five or more amperes, for which there is no apparent reason. There are however on ordinary streets usually almost imperceptible differences in the condition of the track and it is very probable that these are the cause of many strange variations, which are noticed not only on individual car tests but in the power station from day to day.

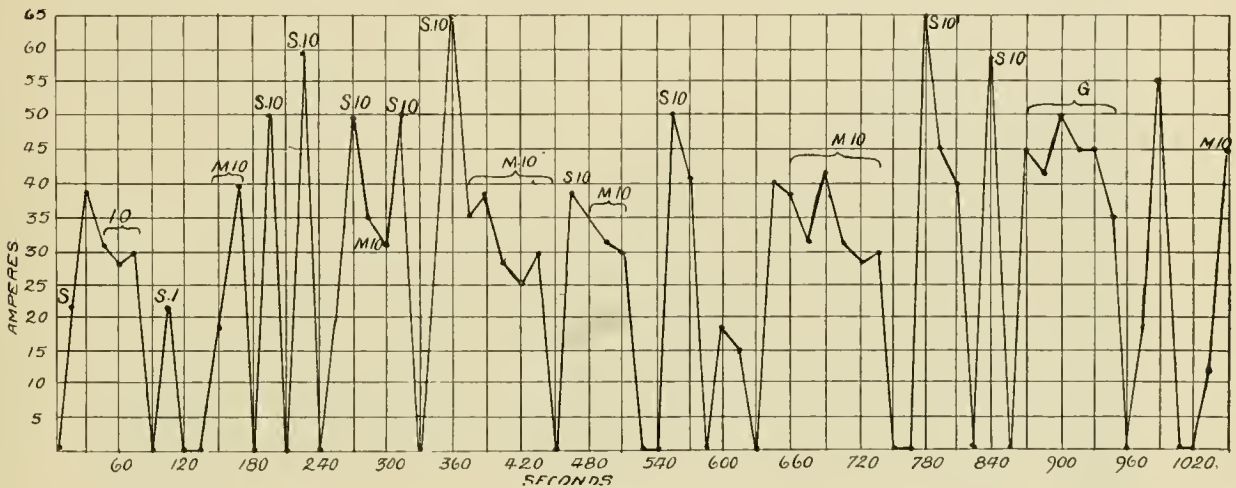

FIG. IV.

The low readings on the seventh point are partly accounted for by a very slight favoring grade. Other conditions were apparently identical and while the test did not pretend to be hair splitting it was carefully made and represents every day conditions. Of course in prac-

### A BRILLIANT SCHEME.

The Electrical Engineer commends to inventors the designing of an electric car speed indicator, which would enable the motorman to tell the speed of his car at a

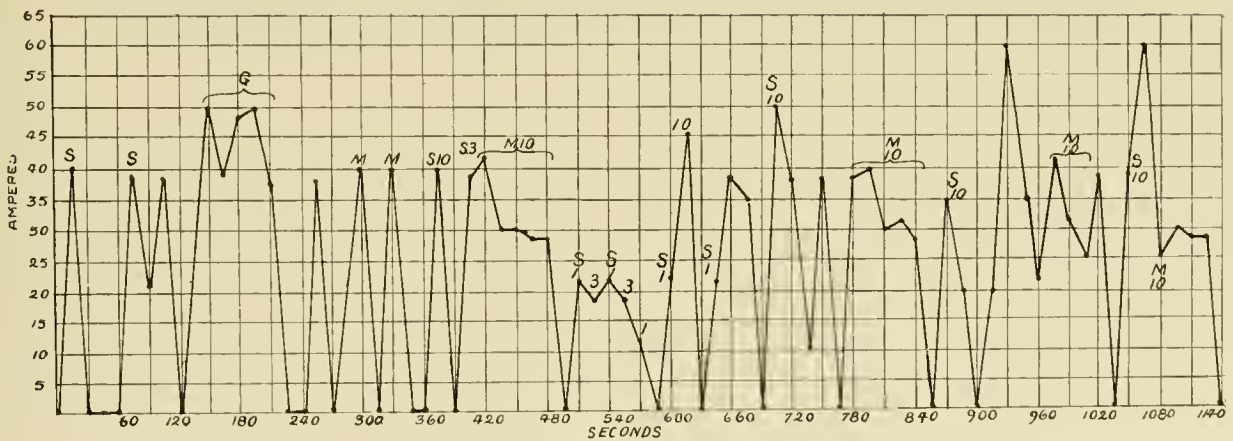

FIG. V.

tice the controllers are never stopped long on any but the third and tenth points. There are also variations which come in to influence results, and which are most difficult to account for. This is shown by the record of the speeds during the above readings, which were as follows: First

glance, and so tell whether he is violating the city ordinance as to speed. "That it has become a necessary adjunct for electric cars is obvious," says the Engineer. We always had the impression that a motorman who could not tell how fast he was running within two or

three miles per hour ought to be taught better or fired. Fine distinctions are not necessary, and as a competent man can determine very closely his car speed, what is the use of putting such a plaything as a speed indicator on a car. If the schedule time is too fast, danger of accidents will be increased. The maximum speed has very little to do with it. It is the temptation to sacrifice safety for time and take risks that would not otherwise be taken that kills both motors and people. Speed indicators either of the "visual" or "audible" type would only complicate difficulties..

If, however, some "indicator" becomes necessary, we suggest the most effective would be a governor geared

feet can be carried. This makes the construction of false works very difficult. One of the most serious difficulties is in regard to surveying the steep and irregular mountain side. It was found impossible to project the line from data obtained from the preliminary survey, because it gave such an inaccurate idea of the contour of the land and curves could not be located with sufficient accuracy. Another peculiar difficulty met at first, was with the curves which were planned as if they were to be laid on level ground. Consequently the inner rails would fall short. As the design of the track required that all joints should be exactly opposite one another this interfered considerably with the work. Metal ties bolted to the

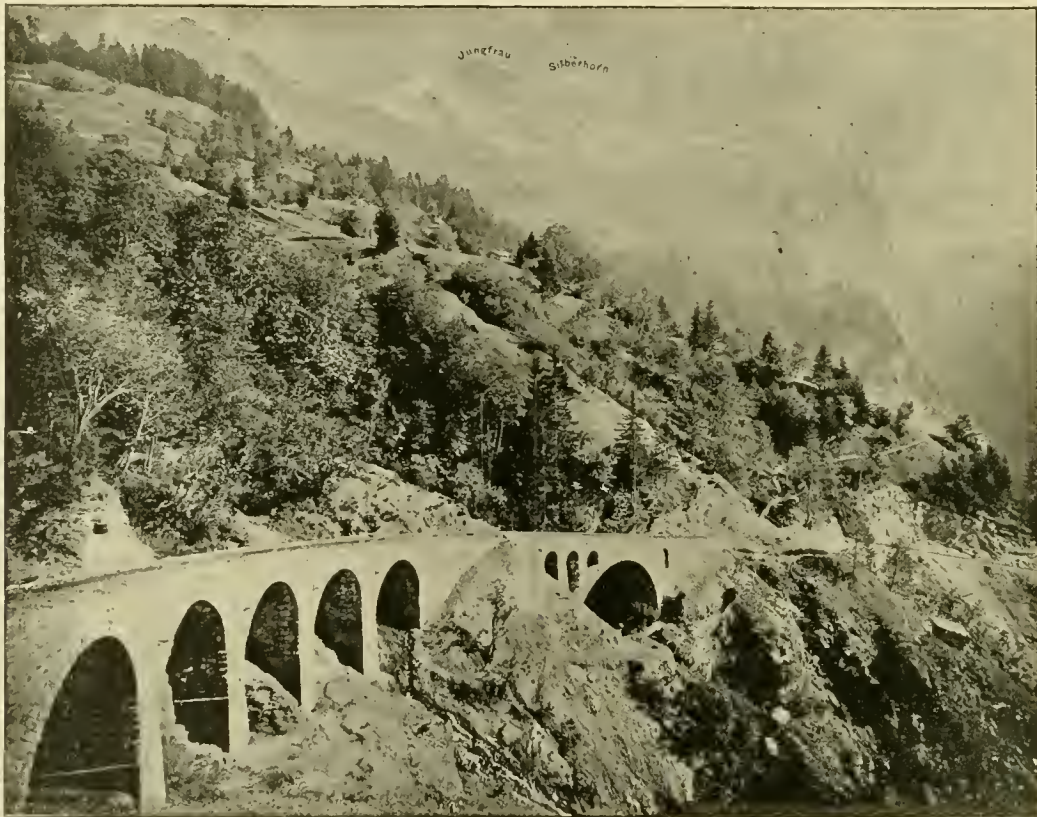

RACK RAILWAY UP THE WENGERN ALP.

to the car axle, which would automatically operate a stuffed club and thump the driver in the back of his neck when the speed limit was overreached.

#### RACK ROAD UP THE WENGERN ALP.

The last of the Swiss mountains to be ascended by a rack railroad is the Wengern Alp, on which the road was opened to traffic last summer. Being the newest road, of course advantage was taken of the experience gained on all the previous Swiss roads of the kind, and the railway in question represents the most improved practice. T. Delmar, in the *Railroad Gazette*, from which our engraving is taken, gives an account of some of the difficulties encountered in the building of this mountain line. The cost of transporting material up the mountain is something enormous. Then, too, no timber longer than 20

rails were used throughout. It is thought by many that this will be the last road of this kind to use steam. Coal per mile operated, costs from \$1.40 to \$3.40. Electricity generated by water power as on the Stanserhorn cable road described last month, is to be the coming power for mountain roads.

EIGHT men were asphyxiated in the basement of the cable plant at Kansas City, recently. A strand of the cable wrapped around and broke a gas main. The men were sent to repair the pipe, with the above result. Superintendent C. P. Kline was one of the victims.

By the bursting of a steam pipe in the power house of the Philadelphia Traction Company five men were injured.

## INSURANCE RATES AND POWER HOUSE CONSTRUCTION.

In spite of the peculiar and unreasonable policy of insurance companies as shown by some of their rulings, the average station manager and constructor has much to learn from them as regards the proper construction and maintenance of buildings. If mutual insurance is to be made a success by street railway companies it must be taken up in a thorough manner. All the good points of the "old line" management must be strictly adhered to and the hap-hazard and unbusiness like points rejected. The great weakness of the old line management is in making rules and not enforcing them. It is this policy which works injustice to the insured and loss to the companies themselves. If competent inspectors were hired who would look over every risk, such odious rulings as were discussed last month, in regard to trolley circuit power renting, would not be necessary, or rather thought necessary.

"But," they cry, "we are too poor to maintain inspectors to enforce our rules." Very well then, charge higher rates if necessary and maintain inspectors. They would in the end save money, both for the insurers and the insured. They would not be a very great expense if hired by the underwriter's associations, and if their work was carried on according to a proper system. Local agents are entirely unfit for this work from more standpoints than one. A system of expert inspection would greatly improve the condition of insured property and so ultimately decrease fire losses.

The rules recently adopted by the Underwriters International Electric Association and in force in the majority of states east of the Mississippi river, furnished much food for reflection by owners of street railway plants. These rules specify a certain standard of requirements for power houses, car barns, and repair shops. For these standard types of construction a base rate is charged. For each item which does not conform to the specifications a certain amount is added to this rate. Thus in building a plant it is possible to know just what the insurance rate will be.

The standard power station is described as one built of brick or stone; one story, without basement; roof and roof supports of metal; floor of brick, cement, stone or earth; cornice, brick, stone or metal; eaves 15 feet or more from the ground; no combustible finish or finish leaving concealed spaces; division walls brick or stone with standard fire doors. The stack must be brick, or if of iron, must be outside and on a brick foundation; wire tower of same material as the station proper; stairs and elevators in a tower, outside building, or with self closing hatches; heating by steam, hot water or hot air with the piping on iron hangers and free from woodwork; lighted by gas or electricity installed according to rules; occupied only for the legitimate uses of the station itself and unexposed within fifty feet unless protected by a fire wall. The electrical arrangements are to conform to the rules of the Underwriters International Electric Association with

which most of our readers are familiar. The switchboard must be incombustible or of skeleton wood. A competent man must be kept constantly in the dynamo room during running hours. A watch clock making an hourly record must also be kept and the dials kept on file for inspection. Waste must be kept in metal cans which are emptied every day. Floors must be kept clean and the station must not be a storehouse for oils of any kind. Tops of boilers are to be clean from soot and dust. Three pails for every 1,000 square feet of floor area are to be kept filled—half of them with dry sand, the other half with water. For every 5,000 square feet of floor space, 100 feet of folded hose must be kept attached to a standpipe capable of supplying 1,000 gallons for every 5,000 feet of floor area at a pressure of 25 pounds. There must be two double hydrants connected with a 6-inch main within 250 feet of the building and a fire department within 1,000 feet of the building; also a telegraph fire alarm within 100 feet.

For a building answering to these specifications, the rate is 50 cents, and to this is added a definite amount for each particular which does not come up to the standard. Thus 10, 20, 40, and 80 cents are added for two, three, four and five story buildings. Veneered or frame walls add 25 cents; shingle roof 20; tin, gravel or slate roof 10; wood floor 20; wood finish 15; metal stack through shingle roof properly ventilated 25; metal stack improperly ventilated and through anything but metal roof 100; wire tower if not as in requirements, at least 25; concealed wiring 25; wires under floor unless in an approved conduit 25; switchboards, rheostats, and feeder equalizers unless standard 50 cents each; oils stored in station 100; ashes in combustible receptacles 100; tops of boilers if not kept clean, 25. For the balance of the items not conforming to the standard, additional rates of from 5 to 15 cents are charged.

For car barns the general specifications and charges for deficiencies are very similar to those for power houses. Pits if used must have brick, cement or earth floors, and be lined with the same material. They must not be extended under the floors or connect with one another. Steps must be of brick, stone or iron. Even for this kind of pit, however, the charge is 15 cents extra. If the building adjoins other buildings the division wall must be of brick or stone at least 12 inches thick, and free from all openings. Track doors must swing outward and clear all trolley span and pull off wires and each other. All tracks must run clear to street without transfer table. Tracks must terminate in stop blocks, allowing 4 feet between end of cars and building. No frogs or crossings permitted inside of buildings; stoves not to be used for heating cars; repairing, painting, varnishing and finishing not allowed in the building; trolley wire must not be put in a trough, and the hangers must be put near enough together to prevent the wire touching the ground in case of breakage. A cut-out switch located outside the building must, when opened, cut out all the wire inside of and within 100 feet of the building. The electric lights must be controlled by a switch independent of the main feeder

switch. No portable lights are allowed except in pits, and these must be connected by two flexible rubber covered wires in a length of woven hose, and controlled by a switch outside of the pit. Rails must be double bonded with No. 4 soft copper wire. Cars must not be left with the trolley on. The presence of a competent foreman or watchman is required at all times in the building. Lighting and lubricating oils may be kept in a fire-proof building near the barn, and one day's supply may be kept in the barn. The oil room may be the lamp room. Two bushels of clean, dry sand must be kept in the oil room.

The base rate for a standard car barn is 75 cents. The charges for deficiencies are similar to those on power houses. Car stoves add 10 cents; portable lamps not according to rules 25; feeders running through building for other than light and power in the building 25. If transfer table is used, the rate on cars (which is 25 cents in excess of the building rate) is increased 15 cents.

The schedule on repair shops is almost identical with that on car barns. The base rate, however, is \$1.25.

The above rules and rates are full of suggestion to present and prospective owners of plants.

#### A "HITCHING-ON" ORDINANCE.

The articles in the REVIEW advocating the passage of a protective ordinance in every city, which should make it a fineable offense for children to hitch on cars, has already been followed out in several places. Among others, is Madison, Wis., and George H. Shaw, superintendent of the electric lines, sends us the following copy of the new order:

AN ORDINANCE for the prevention of accidents to children.

The common council for the city of Madison do ordain as follows:

SECTION 1. Any boy or girl of the age of four years and upwards, who shall wantonly, mischievously step or sit upon the steps of any railway car for the purpose of surreptitiously riding thereon, or shall in any manner cling to the steps or railing at either end of any street railway car, or to the sides thereof, while the same is in motion or under way in its track, for like wanton, mischievous or sporting purposes or intentions, shall be subject to and pay a fine of not exceeding ten (10) dollars as the court may in its discretion determine.

SECTION 2. Parents or guardians of any child who shall knowingly permit such child to play upon any street railway car, shall upon conviction be subject to and pay a fine not exceeding ten (10) dollars as the court may in its discretion determine.

It will be noticed the responsibility is placed directly on the parents and guardians, who are thus encouraged to execute the slipper act where it will do the most good on the obstreperous small boy.

THE new eastern office directory is increased by one more. The Fulton Truck and Foundry Company of Cleveland has established its eastern branch at 26 Cortlandt street, New York City, in the Havemeyer building. William Hazelton III is in charge as general eastern agent. Mr. Hazelton is too well known to the trade to require special attention further than that he is fully acquainted with the merits of the new steel truck, the Imperial, and will take pleasure in explaining it to anyone who is interested.

#### A ST. LOUIS VETERAN.

The oldest street railway employe in St. Louis, is a blythe young man of 64, with a record of forty years a car driver. His name is James T. Manley, and, like the veteran of Boston, a sketch of whom was given in December, Ireland was his native heath.

In 1846 Manley came to America. He was then seventeen, and was engaged as an errand boy by a New Yorker, afterwards going to Philadelphia. Several vicissitudes landed him in St. Louis in 1850, where he was hired by a transportation company to cross "the plains" with an overland train. Surviving Indians and other incidents he returned to St. Louis but went west again in the governmental service at Fort Laramie,



JAS. T. MANLEY.

where he remained two years.

In 1854, the Honorable Erastus Wells, lately deceased, employed Manley in his 'bus service, as driver. He then made 14 trips one day and 16 the next. This he continued until Mr. Wells established the first street car line in St. Louis, when he entered the new service, driving the first car which made 20 to 25 trips a day, going east to Fourth Street and West to Fourteenth.

In 1861 horse-car driving was deserted for the more exciting field of usefulness in the late war. Manley enlisted in Company C, First Missouri infantry, under General Stirling Price and served to the end of the war.

After the war he reentered the car service under Mr. Wells. The next few years were uninterrupted except by a visit to Ireland to bid his mother farewell.

In 1869 Mr. Manley was promoted to a clerkship in the office of the Market and Olive Street Railway Company and in 1871 was married. Four years later having lost his two eldest children and becoming discouraged he resigned to go into business for himself, as shopkeeper. This, however, proved an unfortunate venture and after three years he returned to the front platform, working on different lines.

In 1883 he entered the employ of President John H. Maxon, then of the Lindell line. Mr. Manley drove on two lines of this system making 10 trips one day and 14 the next.

When, four years ago, the Lindell company began to run its electric equipment, Manley went into the new service. With one change, a six months service with the St. Louis Suburban, Mr. Manley has been a conductor on a Lindell train ever since, running two trips in the morning, beginning at 6, and six trips in the evening, beginning at 6 o'clock.

"I wish I could make collections as easy as that," said the merchant to the conductor.

"Mine may seem good but they're only fare." replied the conductor.

ANOTHER CHANNEL PIN.

We illustrate a new patented device used in bonding rails for electric roads, and designed to take the place of the old style channel pins, which have been so long in use.

This device is called the Acme bond cap. As shown, it is a common cylinder closed at the bottom like a cartridge, with a slot running part way through the wall and the entire length of the cap. The cap is driven through a hole in the rail, made in all cases  $\frac{1}{32}$  of an inch smaller than the largest diameter of the cap. When the bond wire is inserted and the cap driven into the rail, the weakest point of the cap, which is where the slot is cut, collapses, and the two sides are forced together, forming a burr on the inside, which engages with the copper wire and holds it firmly in position.



It is claimed that this cap is thoroughly waterproof and makes absolute contact on all sides of the bond wire, is easy to insert, and holds the wire with a vise-like grip. It is being placed upon the market by Goodhue & Lincoln, 1564 Monadnock block, Chicago.

A TALL STORY.

Jermiah Jenkins is the alliterative appellation appended to a driver of a Greenburg, New York City horse car. He has since been rebaptised Lengthy Jenkins, probably on account of his "talth." His breadth is not nearly in proportion. Horse car driving was a serious thing with Mr. Jenkins, as the confined position, shown in our excellent engraving, was rapidly warping his willowy figure into the shape of a letter S.



But Mr. Jenkins is a man of ideas, one of them is illustrated. It is a hole idea in one picture. The head that contained the idea is projected through the hole, allowing Mr. Jenkins to assume a graceful darsartean position and attend to business at the same time.



He also has the advantage of a free hand movement, as pictured, and many a future alderman of Greenburg owes his career to Mr. Jenkins "extensible kid catching movement," for which he is blessed by all the mothers on the street. Long live Mr. Jenkins.



THE MULE WAS SICK.

A little town down in Indiana has a street railway line. That is, the driver, conductor, president and superintendent all one person, so alleged. The officers of the road announced sometime since that better service would be given the denizens of Podunkville and notice was posted to the effect that Monday was the date for the new service. But alas for the vanity of human expectations, a catastrophe happened that delayed the change and a big paste-board sign at the "corner" announced the bit of heart rendering news. "No new service to-day, the Mule is sick."



SAN FRANCISCO'S BIG MORTGAGE.

At a meeting of the stockholders of the Consolidated Market Street Cable Railway Company of San Francisco, February 6, an issue of \$17,500,000 in bonds was voted, to be issued in the form of a blanket mortgage.

The outstanding bonds of the Consolidated amount to \$7,000,000 and enough of the new issue will be reserved to take them up. The remainder will be used for extension, reconstruction, and further consolidation. The bonds will run forty-nine years at 5 per cent. The old bonds were 6 per cent. The new corporation stands ready to put from one-half to one million dollars into electrical equipment immediately

A LARGE BRIDGE.

The King Bridge Company, of Cleveland, is preparing plans for an iron drawbridge for the New York Central Railroad Company, which, when completed, will be the largest iron drawbridge in the country. The bridge is to span the Harlem River in New York City, and will cost \$3,000,000. The contract calls for the completion of the bridge by next December. It will be 400 feet from end to end and will swing on a central pivot, and when turned will leave a clearance of one hundred feet on either side for passing vessels. The lowest point will be twenty-four feet above the water.

A NEW ENGINE BUILDER.

A local syndicate has bid in the Sioux City Engine Works, of Sioux City, Iowa, assuming the \$150,000 indebtedness and paying \$20,000 equity. They have consolidated with the Pech Manufacturing company and incorporated the Sioux City Engine and Iron Works, with a capital paid up of \$240,000, to operate the two plants together. W. P. Manley, A. F. Call, and T. A. Black, bankers; W. M. Thompson, of Elgin, Ill.; R. H. Brown, of Storm Lake, and R. A. Finkbine, of Des Moines, are the incorporators.

The new concern has a good field to work in and will no doubt find success.

THE Buffalo Street Railway Company shows the tremendous increase of traffic for 1893 over 1892 of 10,000,000, with an increased car mileage of 2,000,000. The increase in the past four years has been 200 per cent.

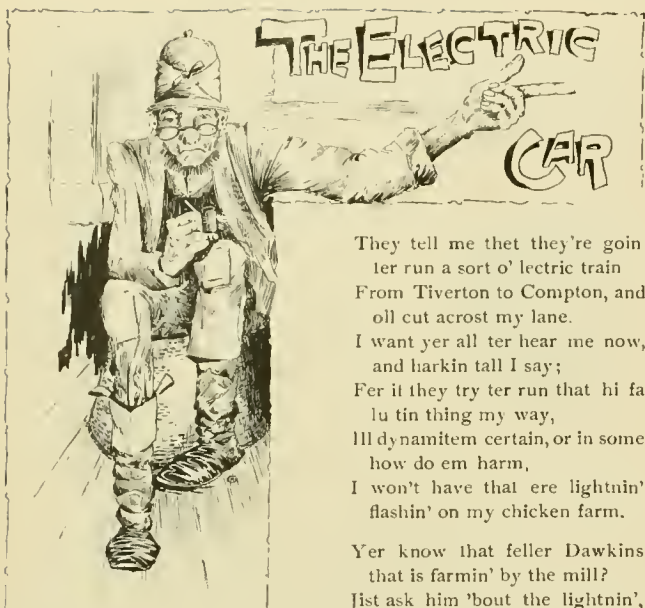

They tell me thet they're goin  
 ter run a sort o' lectric train  
 From Tiverton to Compton, and  
 oll cut acrost my lane.  
 I want yer all ter hear me now,  
 and harkin tall I say;  
 Fer if they try ter run that hi fa  
 lu tin thing my way,  
 Ill dynamitem certain, or in some  
 how do em harm,  
 I won't have that ere lightnin'  
 flashin' on my chicken farm.

Yer know that feller Dawkins  
 that is farmin' by the mill?  
 Jist ask him 'bout the lightnin',  
 fer it struck his brother Bill.

An' knocked the life right out him—laid him deader than a nail.  
 An' then ter think o' buyin' it fer runnin' on a rail,  
 I kaant see what's got in 'em, cause fer me ther aint no charm,  
 I won't have that 'ere lightnin' flashin' on my chicken farm.

I know it's scientific, an' some people think it smart  
 Ter have the thing ter pull 'em, 'stead o' ridin' on a cart;  
 They say "we mus' be stirrin"—an'—"the scheme oll make a hit,"  
 "We farmers is too old"—an'—"the young mus' manage it."  
 I'm waitin' fer the'r hittin', an' I'll raise a big alarm!  
 Ef enny of 'em try ter run acrost my chicken farm.

Why, the people oll be stricken, all the hosses run away,  
 The milk all gittin' sour, lightnin' makes it spile that way,  
 The hands instead o' plowin' oll be ridin' on the thing,  
 An' any amount o' trouble yer the pesky thing oll bring;  
 I tell you what I'm kickin' an' oll raise my mighty arm,  
 If enny of 'em try ter run acrost my chicken farm.

*Henry Lippincott in Chicago Herald.*

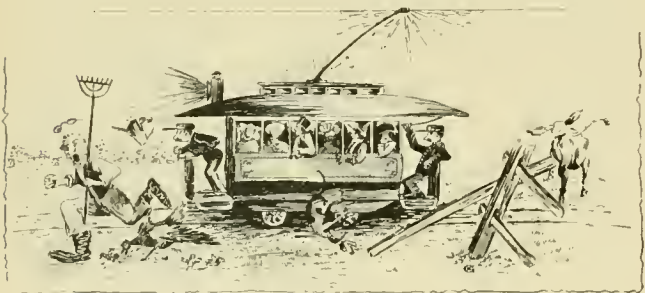

### HOW TO CURE ELECTROLYSIS.

A REVIEW reader wishes to know how to prevent the electrolysis of gas and water pipes by the return current. A year ago this would have been a difficult question to answer, but with the inventions made and the knowledge gained from a study of the subject by intelligent electrical engineers on many roads, since that time, it can now safely be said that this trouble can be almost entirely cured. The first and most important point is to reduce the resistance of the return by bonding heavily with some good copper bond, giving moisture proof contact. Several bonds of this kind are now on the market, which were not available a year ago. Cross bond at frequent

intervals and double bond if the traffic is heavy. Number 0000 wire is none too large for this work. The main objection in the past to depending on the rails and bonding alone, was that the old style bonds nearly always gave defective contact. Their weakness was aggravated by a too light track construction, which gave so much motion at the joints that many bonds broke or became loose, leaving the track circuit open. The channel pin never gave a good contact and the moisture-proof qualities of a cold riveted joint are very uncertain at best. With up-to-date bonds and track work it has been demonstrated that there is little difficulty in maintaining the integrity of the rails and bonding. Wires of sufficient capacity to carry the entire current should be run around all switches, curves and special work, as the bonding can not be depended on at these points. Care should be taken to have a good heavy connection between the power house and the other parts of the system. If the tracks do not run past the power house, a line of old rails heavily bonded and buried will make a good track feeder. If the system is large, track feeders of some sort should be run to several points, so that the return cannot be broken by tearing up track at any one point. A return installed in the above manner will have so low a resistance as to reduce electrolysis to practically nothing. Frequent firm connections to water pipes will reduce the electrolysis on them, although until recently the opposite was thought to be the case. This plan will not take the place of the improvements in the return as before described, but such water pipe connections are a useful aid in reducing the action on the pipes and in a measure giving temporary relief when the return is in bad condition. The connections should be made frequently and at points where there is the most electrolysis. The connections at the pipes must be well made. This plan has been tried with success at Milwaukee, and is described in Mr. Rau's paper in the December 1893 REVIEW. The efficiency of heavy bonding as against other methods has been pointed out by numerous writers in our columns during the past year and with present improvements in bonds can be considered as beyond any doubt.

THE street car spitter is to be abolished in Chicago, also. The Municipal Order League, composed of women, is co-operating with the superintendents of the various lines. Miss Ada C. Sweet, the lawyer, says: "Our great effort is to educate the public up to the point of refusing to tolerate such a nuisance. The great mass of men and boys are not brought up to habits of cleanliness, and it is to these we appeal. We are trying to get the Health Department interested."

Snow blockades and fights between street railway companies and residents along the lines have been incidents of February's great storm. It was impossible to move all the snow at once, and the public, unreasonable as usual, wished the companies to perform miracles in the matter of snow banishment.



OFFICERS, CLERKS, INSPECTORS AND FOREMEN, CHICAGO CITY RAILWAY COMPANY.

SUPPLEMENT TO STREET RAILWAY REVIEW.



- 1 G. H. Wheeler, President.
- 2 Julius S. Grimnell, General Counsel.
- 3 T. G. Pennington, Treasurer.
- 4 Robt. L. Girth, Purchasing Agent.
- 5 M. K. Bowen, Superintendent.
- 6 F. R. Greene, Secretary.
- 7 J. Edle Turner, Auditor.
- 8 John P. Burke, Treasurer's Office.
- 9 W. D. Wood, Purchasing Agent's Office.
- 10 John O'Hare, Supervisor.
- 11 G. W. Knorr, Electrician.
- 12 Chas. E. Hall, Truck Master.
- 13 Edward Campbell, Supervisor.
- 14 C. R. Pennington, Treasurer's Office.
- 15 Robert Stuart, Supervisor.
- 16 Leon Jewell, Superintendent Time Tables.
- 17 Harry H. Brown, Foreman 21th St. Depot.
- 18 Wm. Kurtzman, Elevator.
- 19 Ed Kilbino, Time Keeper.
- 20 Tom F. Turner, Purchasing Agent's Office.
- 21 Andrew Christ, Jr., President's Office.
- 22 Claus Hanson, Foreman 64th St. Depot.
- 23 R. S. Fitch, Westinghouse Electric Company.
- 24 Wm. H. Carter, Foreman 61st St. Depot.
- 25 A. C. Heidelberg, Foreman Cottage Grove Ave. Depot.
- 26 J. F. Johnson, President's Office.
- 27 J. J. Fitzpatrick, General Counsel's Office.
- 28 Geo. O. Nuple, Superintendent's Office.
- 29 C. A. Cogswell, Supervisor.
- 30 N. J. Nagel, Printing Department.
- 31 Wm. Weatherman, Foreman Wallace St. Depot.
- 32 Chas. A. Smith, Time Table Department.
- 33 F. H. Grissold, Inspection Department.
- 34 John McCarthy, Foreman 39th and State Sts. Depot.
- 35 John Keefe, Time Keeper.
- 36 C. A. Spunner, Supervisor.
- 37 J. H. Edwards, Telephone Exchange.
- 38 Henry Brown, Time Table Department.
- 39 M. P. Scott, Supervisor.
- 40 G. F. Baer, Supervisor.
- 41 R. P. Keyes, Supervisor.
- 42 Robt. J. Hill, Chief Engineer.
- 43 Wm. Brotherton, M. Car Builder.
- 44 E. A. Horely, Mechanical Engineer.
- 45 S. T. Collins, Inspection Department.



## PERSONAL EXAMINATION OF INJURIES IN DAMAGE SUITS.

Father Knickerbocker, and presumably all his daughters, are at present greatly exercised over a certain young lady of that city and the "discovery" of a state law, enacted last year, which gives the defendant in a suit for damages arising from personal injuries, the right to demand a physical examination of the plaintiff.

In October of 1892, a collision occurred on the Ninth avenue elevated, in which the petition cites, a Miss Lyon was thrown violently against a seat, upon the floor, and as a result was rendered unconscious for several hours, and received thirty thousand dollars worth of injuries to her spine, as estimated by her lawyers, and in the attempted collection of which sum all this rumpus has occurred.

The daily papers immediately championed her cause vigorously and made a special assignment of big words, for properly writing it up in a manner at once gallant and sensational. The law was "monstrous," "barbarous," "a gross outrage" and "unconstitutional;" while the young woman is "not quite twenty, and an orphan, with a face remarkably beautiful and expressive, with large black eyes, which now bear a mournful expression, and great waves of dark brown hair that reach below her knees."

It is certainly comforting to know that the young lady does not wear false teeth and a wig, though we cannot forbear the suspicion that had the plaintiff been some cross eyed old maid, with red hair, the susceptible reporter would not have felt called on to denounce the law in all the harsh terms used.

The plaintiff's lawyers are temporarily raised on a pinnacle of public conversation, where they stand with upraised hands and vehemently denounce the law and the corporation which dares insist that the damsel with the mournful expression of optics, bare her pretty shoulders before a commission consisting of two physicians and one other gentleman, all appointed by the court. To just what degree modesty is violated beyond what is considered good form at any notable evening function we are not advised, but venture the opinion it can't be much. The furore which has occasioned several thousand female epistles to the several editors, seems to take its vigor, not so much from the mere scantiness of attire prescribed in the bond, as from the fact that it is ordered by the court, and that a failure to comply therewith means a sad, sudden and certain pair of wings to the thirty thousand damages so earnestly prayed for by the party of the first part.

We do not wonder at the position taken by the general public in this case, and on first consideration is only what should be expected of a sympathetic and generous sentiment. It even is no more than is due from society viewed from the standpoint from which the general public looks. It sees only the wealthy corporation with ability to pay and the suffering claimant seeking justice which can never be fully met by a mere payment of dollars, however many. The company, respon-

sible for the injury; the petitioner a sufferer for life; therefore a big verdict is the least that can be done to ameliorate her unfortunate condition.

What the public does not see and seems to have no means of knowing, is, that the world is full of persons whose sense of honor is located far beyond the vanishing point, and who, revolting and unlikely as it may seem, do not hesitate to trade on natural or accidental deformities of the human body, and in many, many cases on alleged physical pains and ills that have not and never had any existence whatever in their precious frames. Others do not hesitate at self inflicted injuries made with the sole interest and purpose of seeking damages from railroad corporations and alleging the injuries as the result of careless or criminal operation of roads. None but those, who like the writer, have had ample opportunity to study the records of the claim agents' department of a great street railway corporation, can have any appreciable conception of the amount, extent and ingenuity of this kind of wickedness. Two years ago the REVIEW made a thorough expose of numerous blackmail suits, in which severe physical injury was alleged, but which had either no existence in fact, or existing, had been caused months or years before and in other cities. To briefly illustrate, one case was that of a man who had lost a leg and claimed \$10,000. from the cable road. It was discovered that no less than two steam railroads had already settled for that missing member, and much doubt exists that it was in the first instance lost in a railroad wreck and not in a lumber camp. Another was a young woman having every appearance of being a perfect lady, who incredible as it may seem, bathed parts of her body and her bed with blood purchased at the stock yards in this city, and was found in great apparent agony and undoubted surplus of gore, by the company's surgeon, for whom she sent. It required fine detective work in both cases to discover the fraud. Within a year past a young man in this city threw himself in front of a cable train, and although the safety device prevented him from receiving the expected injury, it could not a few days later keep him from a partial amputation with a jack knife, of one finger, for which he claimed accident insurance, alleging the injury to have resulted from a Fourth of July revolver.

Commenting on the Lyon case, the Register of Sandusky, Ohio, cites two instances, one of a man and one of a woman, both of whom sued and received \$5,000 damages against that city for alleged personal injuries received from falling on a defective sidewalk. In both cases an almost immediate miracle seems to have been worked by the receipt of the money, for the lameness entirely disappeared in a few days thereafter and has neglected to return. Had personal examinations been made in those two cases, the Register is convinced the verdict could never have been rendered as recorded.

Even where personal examination is allowed, as it is in many places, the defence still labors under great disadvantages. It is only within the last month that a most startling disclosure was made in San Francisco. In

November of 1891, a certain street in that city was being raised four feet to grade. During the progress of the work, a horse car line was operating on this street. On one trip a car containing four or five passengers, met a big truck team loaded with the trimmings of hides and other savory glue stock on its way to the glue works. The car and wagon met at a point in the road where it was impossible for both to pass. After a wordy war between the two drivers, it was decided to push the car back, which was being done, when the car horse, catching a extra flavor of the aforesaid glue stuff and seized with a sudden realization of what the future had in store for him, was taken with temporary panic and jumped the track, dragging the car from the rails, but not overturning it. Among the passengers was one Mrs. Mary Jane Doolin. Now Mary was rudely displaced from her seat when the car went into the mud. This occurred on November 17, 1891, and on February 8, 1892, suit was began by Mary Jane and her husband, against the Omnibus Cable Company, for the modest sum of \$20,000.

The plaintiff called medical and other witnesses who made out for her a strong case. From the testimony on this side of the controversy it was made to appear that Mrs. Doolin has received a concussion of the spine and other injuries, which rendered her almost a physical wreck. On the other hand, it was contended by the railroad that Mrs. Doolin had not been injured at all, and there was an effort by counsel to establish that the woman's injuries were simulated.

A medical examination was insisted on, which was made in the presence of five doctors, including the company's surgeons. It was then conceded that Mary Jane was affected with an ovarian tumor, which the defense stoutly maintained was not induced by the accident, and which of course her doctors insisted could have been occasioned in no other way. Mary came into court in an invalid chair, with blankets and smelling salts, and all the paraphernalia consistent with a confirmed invalid, although it was remarked that Mary constituted on the whole, a decidedly husky and healthy exhibit. However, this idea was quickly disipated when she went through a series of contortions which her doctor scheduled as convulsions, and was carried out of court in a storm of tears and hysterical screams. As usual this did the business; but not yet satisfied the company took an appeal and hung on to that \$20,000.

Ten days later, Mary Jane's family was increased by the arrival of a fine little daughter, and through some strange coincidence the tumor seems to have taken offense and left for parts unknown, and has not been seen since. Mary, however, continued to push her suit as vigorously as ever and worked the tumor racket right along, until within the past month the company accidentally learned of the above and will ask to have the case set aside. It was a good one on the doctors and a close call for the company.

But we will not weary our readers with a recital of facts and cases of a similar nature, which would require many pages. The manager of every steam and street

railway of any size can recall them by the score. In view of the fact that even with the privilege of personal examination by the defendant's medical staff, it is not always possible to prove the real state of affairs, how highly important becomes the right to make such examinations by properly appointed and suitable commissioners.

In the case specially in point, that of Miss Lyon, we do not assume to question the truthfulness of her statement and the existence of all the injuries she sets forth. To all appearances she is justly entitled to damages, and if so, we trust the law will allow her proper compensation from the railroad company; but the court, Judge Pryor, has placed himself in a surprising position by tempering his order for the examination with an official statement that the law was a bad one, an outrage of personal rights, and that he only granted the petition because he was powerless to refuse it.

As long as it is necessary to resort to courts of law for the enforcement of the golden rule, just so long will unscrupulous and designing persons scheme and contrive at means to defraud and rob railroad corporations; and just so long will the innocent suffer with the bad, and have to prove their case to the extent of personal examination if justice is to be done. The individual who really has an injury, is in no way outraged to be required to submit to a personal examination by commissioned doctors, at his or her home; and a really honest person instead of hesitating should rather insist on such examination, as the quickest, surest and most effective manner of establishing the truth, rather than being dragged for days before the public in a court of law. Our own, and by no means limited experience in such matters, assures us that where actual claim exists, companies are only too glad and willing to settle out of court for any sum within reason; for where real injury exists they are absolutely sure to get an adverse verdict and have a big lawyer's bill in addition. The fact that of the amounts sued for in the courts of Chicago for personal injuries are finally settled in or out of court for not to exceed 5 per cent of the amount claimed, shows most clearly the enormous amount of chaff that in the eyes of the public passes as wheat.

A case which will not bear close inspection is ninety-nine times out of one hundred an unrighteous one.

Commenting on the New York case, the Philadelphia Record is authority for the following statement:

The New York judge who recently ordered a physical examination in the case of a young woman who had brought suit against the Manhattan Elevated Railroad Company for injuries to her spine, was acting in compliance with a law passed at the last session of the New York Legislature, which, it now appears, is in conflict with a decision of the Supreme Court of the United States. In the case of the Union Pacific Railway Company against Clara Bottsford (an appeal from the Circuit Court of Indiana), in which the woman had sued for alleged injuries to her spine, caused by the fall of a sleeping car berth, and the court had refused to order a physical examination, the Supreme Court in an opinion by Justice Gray, sustained the lower court, and said it appeared to the court that it was an invasion of the sanctity of the person to a degree that the law did not recognize, and that it was inconsistent with common law. Two of the justices dissented, it is true; but the decision, nevertheless, appears to be the supreme law of the land. And there is, therefore, a possibility that it may be invoked before the pending litigation in New York shall have reached its conclusion.

## EXPOSURE OF A PROFESSIONAL WITNESS.

The Siamese twin of blackmail suits, some of which are referred to in the preceding article, is the professional witness, and as many good people are as uninformed on the existence of such creatures as on the attempts to rob through legal authority, we recite below, a case uncovered by the Tribune of this city and recounted in its columns.

The case which called out the discovery of the "witness," arises from an incident on a State street cable car in this city, on which a passenger tendered as fare, first a silver dollar then a \$5 and at last, \$10 bill, all of which were refused by the conductor, who pronounced them counterfeit and finally ejected the passenger, who claims to have presented the money in question at a bank, where it was pronounced good. Be this as it may, he entered suit against the City Railway, claiming \$10,000 damages, and his attorneys advertised in the daily papers as follows.

PARTIES ON STATE ST. CAR FEB. 22  
who saw dispute over counterfeit money please  
call room 9, 89 Madison-st.

This ad. called out the following reply:

CHICAGO, Feb. 27th, 1894—In answer to above clipping will say that if you have use for a professional witness, who is thoroughly competent and reliable, small fee only required, I can be of great service to you. It will probably be to your advantage to address me at once in confidence. Trusting you will act favorably, I remain

Very respectfully,

C. G. ARNOLD,  
245 Washington Boulevard.

The measure of success which attended the newspaper investigation of the alleged witness is best told in the reporter's own words. He called at the street number mentioned, and found a very inoffensive appearing young man, who with his wife, occupied one small back room in a flat, and who informed the reporter he was the C. G. Arnold in question.

"You answered an 'ad' at Room 9, No. 89 Madison street, in regard to counterfeit money case?"

"Yes."

"I am from Crocker & Crocker, the law firm which inserted the 'ad.' We may be able to use you."

"Well, I am sure you will find me a good witness. I have been in a number of cases and I always did my work well."

"Of course you were not on a State street car Feb. 22 and therefore know nothing about the case?"

"O, no."

"Well, I'll give you an outline and then I want you to tell me whether you can testify and what your terms will be."

Then the reporter told the story of Mr. Harmeyer's experience and inquired, "What do you think?"

"O, I can testify to that. But I will want to be posted better before the case comes on; and I'll do it reasonable, too."

"How reasonable?"

"How much do you think it worth?" asked Arnold, cautiously.

He was assured that his visitor had no authority to offer any sum at all, but to get his (Arnold's) terms. After some hesitancy Arnold inquired, "Would \$25 be too much?"

"I think we could pay that much all right. And now I'll tell you: We have a great many cases in which we need additional testimony. If you do this job well you will strike a good thing, if we can depend on you. I suppose we could be sure of having you swear to anything we wanted you to, as you make it a business?"

"O, yes, I'll swear to any thing you want if you post me thoroughly on what you want, and you will always find me a reliable witness. I testified in a case before Justice Everett about two months ago. A divorce was granted on my testimony before Judge Horton a year and a half or two years ago. Next month I have another divorce case out at Kewanee."

"But are you not too well known in the courts? How many cases have you appeared in?"

"About half a dozen. You need not be afraid of that."

"Now we may need another witness in this case, in order to make sure work. Can you get us another man?"

He could, and was rather eager to be employed by Croker & Croker, and repeatedly assured the reporter that he would be found to be a "good witness."

## "AMBER'S" SERMON ON KICKERS.

That woman philosopher that hides her vigorous personality under the pseudonym of "Amber," and writes for the Chicago Herald, in a recent column delivered the following sermon, headed

## A STREET CAR EXPERIENCE.

"I rode in a street car the other night, while the rain was pouring like hot shot at Chickamauga thirty years ago. The car was crowded, the conductor had his hands full, and everybody was growling. If the car halted a moment there was a chorus, 'Nice accommodations for the public!' 'This is a fine way to run a cable!' 'Why don't they lay off for good?'"

"And I thought to myself, how many of these Smart Alecks could or would do anything better if they had the chance? I suppose if the Lord had known what he was about he would have put the round pegs in the square holes and vice versa, but if there has been a big error at the start it is too late to fix things up now. These growlers and fault finders ought to have been put in charge of the world's comfort long ago, there's no doubt about that, but how are you going to help things along now by bemoaning the fact that they were not? No doubt there would never have been a blunder made if things had only been managed right by the ruler of all things. Cables would have run like feathers through oil, conductors would have been large souled Sidneys and courteous Bayards, The rain itself would have been gently checked before it fell, and life for every one of us would have been just "one grand, sweet song," had the Smart Alecks had a chance. It is too bad humanity should have been such a sufferer all on account of a little error in the primal deal."

The rapid transit editor evidently never saw that "copy."

A STORAGE BATTERY COMPANY TO BE ENJOINED.

The Brush Electric Company and the Consolidated Electric Storage Company as co-complainants, have sued the Electric Storage Battery Company and W. W. Gibbs president (manufacturers of the chloride accumulator), for infringement, in the United States Circuit Court for the district of New Jersey. The suit is brought on the Brush Storage Battery patents, recently sustained by the United States Circuit Court of Appeals, more especially patent No. 337,299. The motion for preliminary injunction will be heard before Judge Green, at Trenton, on February 20.

PROPOSED GRADE CLIMBER, AT LAWRENCE, KAN.

The Athens of the Sunflower State is Lawrence. To this town, therefore, Kansans look for all the most advanced ideas of whatever description they may be—ethical or electrical. The magnificent state university on which the state has recently expended \$150,000 in new buildings, is at the edge of the town, with the entrance to the grounds on Adams street. Adams street is at present a path 1,500 feet long, with a rise of 115 feet, and up this incline the seekers after knowledge must perspire, in order to acquire the learning supposed to inhabit the elegant buildings. With an eye single to the alleviation

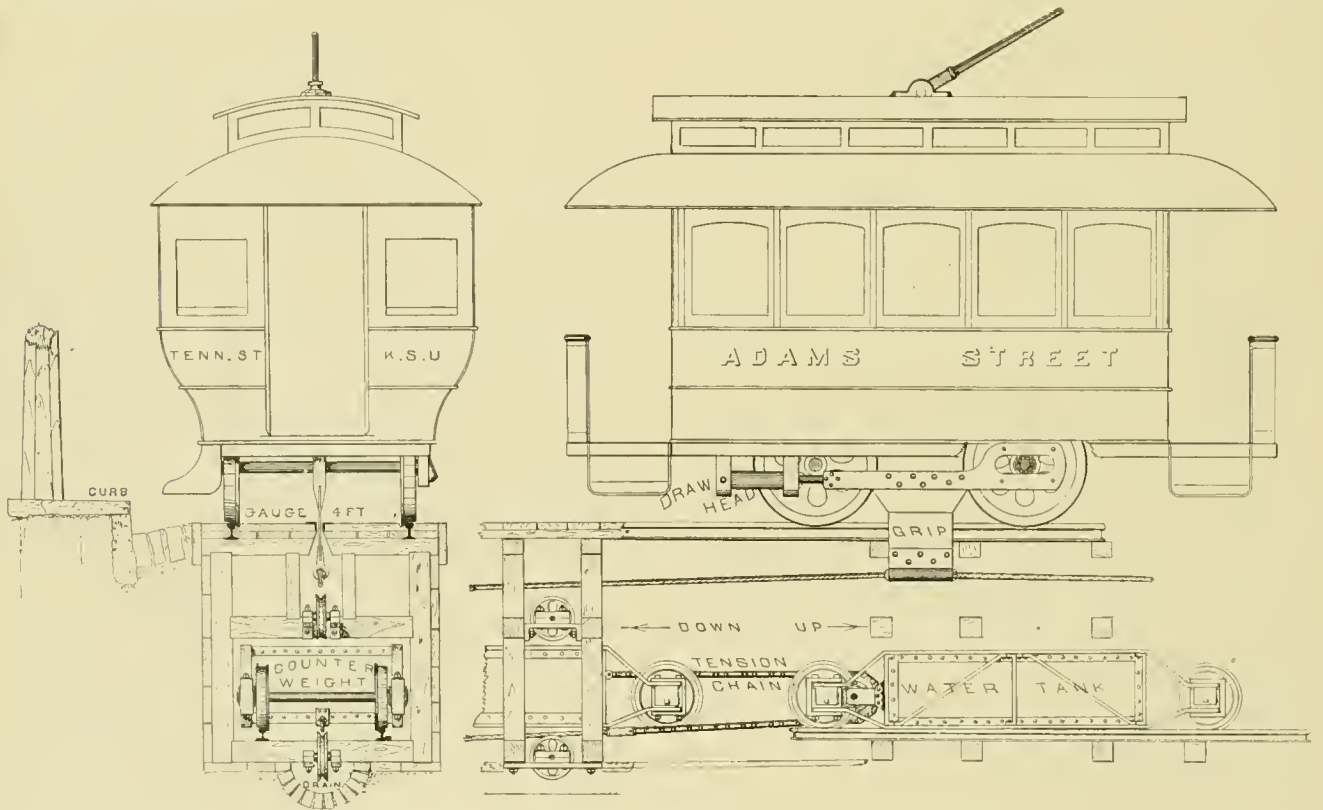

ELEVATION AND CROSS SECTION OF SYSTEM PROPOSED FOR LAWRENCE, KAN.

COST OF TRACTION IN FRANCE.

Electricite, the French journal, gives the following figures for the cost of street railway traction in France. The figures are per kilometre equal to 3,280.7 feet, and, in francs, one franc—twenty cents.

	FRANCS.
Horse traction on the tramways of the General Omnibus Company in Paris.....	0.612
Horse traction at Frankfort-on-the-Main .....	0.590
Horse traction on the Southern tramways, Paris.....	0.542
Horse traction on the Northern tramways, Paris.....	0.516
Traction by furnaceless locomotives on the Rueil and Port Marly line.....	0.450
Horse traction on the Rouen tramways .....	0.407
Mekarski compressed air traction at Nantes .....	0.343
Electric traction at Frankfort-on-the-Main.....	0.309

IOWA LEGISLATORS have a bill on hand to make street railways pay the employes each day.

of this trouble, civil engineer Holland Wheeler proposes an inclined railway up the Adams street hill.

The engraving shows the idea as a conduit fitted with track, upon which runs a truck carrying a counterbalancing weight of water. The water is supplied at the top of the hill by means of a stopcock from the city water main, operated from the bottom of the hill by the conductor of the car. As soon as the tank is full the counterbalance begins and the cars ascends. When the tank reaches the bottom of the hill the water is automatically discharged and the balance truck runs up empty. The hill line is a separate installation and the grip on the rope is to be permanently fastened. The rope will be driven by a stationary motor, which will be operated from the trolley as ordinarily and controlled by the motorman on the car.

It is expected that the state will furnish the power from

its own fine and ample electric plant at the university. There will not be traffic enough to warrant the building of the plant as a commercial enterprise, but it is hoped that the state may be induced to make appropriation for this much-needed improvement and give the students not only the institution but also the means of getting to it.

The proposition has not yet been acted upon, but is feasible and urgently necessary, as there is no direct carriage road up this brief but difficult hill, which the seeker after knowledge must climb. We hope to see Mr. Wheeler successful in carrying out his plans. A somewhat similar road was recently described in this magazine as operating on the Canadian side at Niagara Falls. In this case, however, two cars were used to counterbalance and the extra counterbalance to equalize the load was a tank of water carried beneath the car floor. The line at Niagara has worked successfully.

got accumulator traction, which does not seem to pay, and Blackpool has a conduit system laid in the ground, which suffers, or used to suffer, from periodical inundation. The two electric railways in England—those in Liverpool and the City of London—are giving unbounded satisfaction; so much so, that the former has been taken over from the contractors long before the expiration of the guarantee, and is already undergoing extension."

The fact that the trolley has gained its entrance into New York is the only mistake of the Gazette, but the spirit of the paragraph is right for progress. No rapid transit item has ever produced the comment of the English press to such an extent as the Metropolitan offer, and we hope that English genius may add its quota to the sum of experience to be gained by the competition.

THE Chicago General Street Railway is putting in a small steam plant to charge the storage battery on its lines.

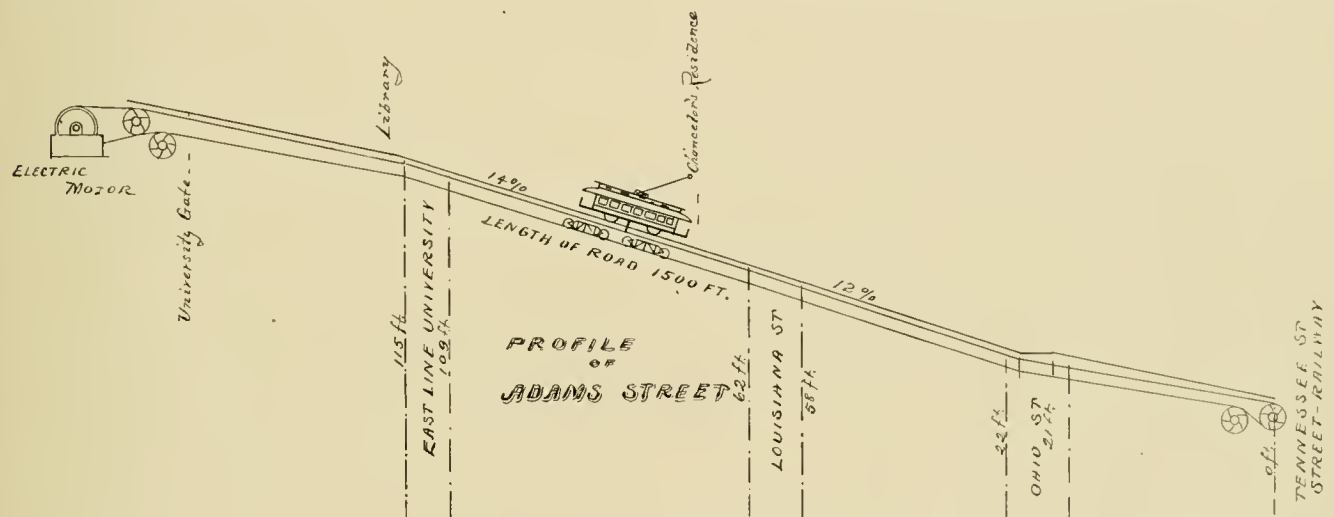

## A LIGHT FROM LONDON.

That the most conservative press in the world should champion the trolley may be a surprise to many of our American howlers. Here is an extract from the Pall Mall Gazette, London:

"The Metropolitan Tramways Company, of New York, having made the generous offer of a £10,000 prize to any one who will produce by March, a working system of traction possessing all the advantages and none of the disadvantages of the overhead wire or 'trolley' system, it remains to be seen what the scientific world can produce. It is rather forcing the growth, this artificial stimulus, for the 'trolley' is a very remarkable development from the system of a few years ago and civilization can well afford to pause at it. We may come to balloons in time, but meanwhile the 'trolley' which has been stifled in New York by the blind and utterly unreasoning opposition of the press, is doing a work in all the other great cities of America which we over here may well envy. The overhead wires are no great disfigurement, as any one must admit who has seen the admirably equipped line in South Staffordshire; and the smooth, swift running of the cars is beyond comparison. Coventry alone of English towns has had the courage to give over its streets to this new system, if one except a single country road at Leeds. Glasgow fought shy of it when the question came up; whilst Birmingham has

## PENNSYLVANIA TRACTION COMPANY.

One of the biggest networks of electric railway tracks in the great state of Pennsylvania is owned by the Pennsylvania Traction Company, of which ex-Senator John J. Patterson is president and John Hertzler secretary, with offices at Lancaster, Pa.

The company now operates fifty miles of electric line and will build seventy-five miles more in the spring and summer of '94. It leases the Lancaster & Philadelphia Electric Railway, the Lancaster City Street Railway Company, the Lancaster & Columbia Railway Company, the Columbia and Ironville Street Passenger Railway, and the Columbia & Donegal Railway Company.

The superintendent is W. J. Armstrong and the purchasing agent John S. Graybill.

ENGINEERS are at work preparing for the construction of elevators to carry passengers to and from the Brooklyn elevated railroad stations. They are to be operated and lighted by electricity. The new plan will be put in operation first on the Broadway line.

SOME Chicago North shore cars are being equipped with the Chicago air brake.

## A GRAPHICAL METHOD OF LOCATING FEEDING POINTS FOR ELECTRIC RAILWAYS.

BY WILLIAM C. BURTON.

In electric railway work we cannot have as exact a knowledge of the actual current which will be required, as we have with lighting systems, and since also the variations of current are much greater and more frequent, there can be no exact and accurate way of determining feed wire, but the following method has been found useful as an aid to the judgment of the designer. The only assumption necessary when using it, is the average current required per car at different points on the road, and this can be estimated with reasonable accuracy.

First, find the average distance of each car on the line from the power house, when running with the given headway and speed. This is easiest done by locating the cars in their mean positions on a map of the road, and then measuring their distance from the power house. Then, assuming the current required per car and the allowable drop in pressure in the feeder, calculate the number of circular mils of copper required for each car, to allow the given drop, at its determined distance from the power house. If it be assumed that the resistance of the return circuit through rails, earth, and track feeders, is equal to that of the feed wire, (this is found to be approximately true) then the formula

$$\text{Circular mils} = \frac{20 C. D.}{V.}$$

gives the required circular mils, when C=current, D=distance in feet from power house to car, V=allowable drop in volts.

A curve must now be plotted, the abscissa of any point of which represents the distance from the power house, and the ordinate represents the total circular mils of copper required by all cars beyond the given point (add circular mils for each car).

Now, assume on the curve the location of the last feeding point, at such a distance from the end of the line as will give the right drop in pressure in the trolley wire. Through this point draw a horizontal line. At a distance representing 211,000 circular mils (if Number 0000 wire is to be used) above this line, draw another parallel to it. The point at which this second line intersects the curve will give the second feeding point, since its abscissa represents the distance from the power house at which additional copper equal to a Number 0000 wire becomes necessary, to carry the cars with the given drop. Above the second line draw another at the same distance and locate the next feeding point, etc.

If there is a distance vertically between the last line and the highest point on the curve, less than represents a Number 0000 wire, of course the last feeder will have to be of a smaller size. If the distance between any two feeding points is greater than will give the assumed drop

in the trolley when the maximum number of cars is located between the points, then split feeders or two or more smaller feeders must be used. Frequently, however, by slightly changing their location, feeding points may be placed at or near the intersections with branch lines (for which feeders must be separately calculated) so as to furnish current partly to each line, thus utilizing a single large wire in place of two or more small ones. By so doing a 100-car road has been fed entirely through 0000 wires without the variations of pressure becoming greater than was allowable.

If it is desirable to take into account grades or other causes requiring extra large current on certain parts of the road, this may be done by allowing greater current per car at these points.

Example:

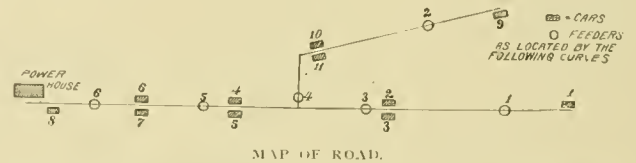

Car Number.	Distance from Power House.	Circular mils required per car, from formula.	Total circular mils required at given distances.	Current per car = 30 amps. Allowable drop = 80 volts.
1	30,000	224,000	224,000	} South Branch.
2	20,000	150,000	524,000	
3	20,000	150,000		
9	28,000	210,000	210,000	} North Branch
10	17,000	128,000	466,000	
11	17,000	128,000		
4	12,000	90,000	1,270,000	} Main line to junction.
5	12,000	90,000		
6	6,000	45,000	1,360,000	
7	6,000	45,000		
8	1,000	8,000	1,368,000	

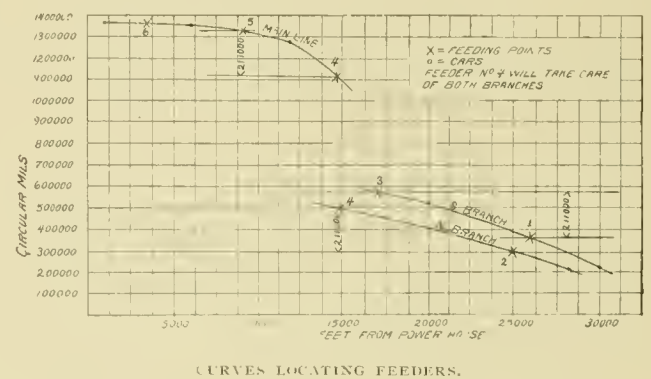

As shown by the curve, five 0000 feeders are required and a No. 3 wire must be used for a short feeder to take care of the cars near the power house. No two of these feeding points are far enough apart to require split feeders or mains, as the road is double track and the two trolley wires will carry the cars between the points with small drop.

Although this method may seem rather long, the operations are very simple, and it takes a comparatively short time to locate the feeders for a large road.



## STREET RAILWAY LAW.

EDITED BY MR. FRANK HUMBOLDT CLARK, ATTORNEY AT LAW, CHICAGO.

*Care required to Prevent Injury to Child.*

Where those in charge of a street railway car know that a child of tender years is in danger of injury, and they may, by the exercise of ordinary care, avoid injuring such child, and fail to exercise such care, the question of the negligence of those having the care of such child will be immaterial, and the railway company will be liable to the child.

At the time of the accident the plaintiff was an infant not quite seventeen months old. He was struck and knocked down by one of appellant's horse cars. The child was so young as to be incapable of exercising care, and cannot be charged with negligence.

The question in this case is whether the driver of the car could have avoided the injury to the plaintiff, after the latter had been discovered to be in a place of danger. Even though the plaintiff had come into such position through the negligence of those having him in charge, the defendant's servant, who had control of the car, was bound to use reasonable care in avoiding an injury to the plaintiff, if he saw, or, by the exercise of ordinary prudence, might have seen plaintiff's peril.

Where the person in danger of being injured is an adult, the defendant will only be liable for wilful injury or gross negligence, on the ground that the adult will be presumed to have the capacity of making some effort to remove himself out of the way of the threatened peril. But in the case of a child of tender years, the defendant will be liable for the want of ordinary care.

In the present case, the driver of the car admits that he saw the plaintiff upon the crossing before the accident occurred. One witness testifies that the child was on the track. Other testimony is to the effect that he was a short distance south of the track. The horses attached to the car were not walking, but going along in an ordinary trot. The driver says that when he first saw the child, it was facing south, with its back to the approaching car, and that, when he, standing on the front platform, was almost abreast of the child, it turned and ran into the car. The little babe was evidently startled by the noise of the car behind it and, turning, ran child-like into the danger instead of going away from it. Under all the circumstances, it was for the jury to say whether he did or did not use ordinary care and prudence in trying to avert the injury after he discovered the danger. There was evidence enough to justify the court in submitting the question to the jury.

The parents of the plaintiff were persons in humble circumstances. They had a small grocery, and lived in the same house where the store was kept. They tended the store themselves, and the father was engaged part of the time as a teamster. The baby was strapped in the baby-carriage and taken out for an airing by a brother fifteen years old. This brother had been in the habit of taking care of the child in this way, and, on the afternoon in question, had wheeled the carriage to the corner where

the accident occurred. While he was looking at some house-movers or at the children playing near by, the baby slipped from the carriage and crept and toddled into the place of danger.

If it be admitted that the older brother was negligent in suffering the child to get upon the street, such negligence on his part would not relieve the defendant from liability, if its servant could have avoided the injury after he discovered the danger.

(Supreme Court of Illinois. Chicago West Division Railway Company vs. Ryan. 131 Ills. 474.)

[NOTE.—Gavin vs. City of Chicago, 97 Ill. 66, was a case of personal injury to a four-year old child by being caught in a swing bridge. The Court said in the opinion: "The bridge, in the condition it was then in, was reasonably safe for all persons using the slightest care for their own safety. No duty rests on the City to make such bridges safe for children to play around or upon, nor is it expected that parents will allow their children to occupy such dangerous places as playgrounds, and if they wander from their homes without the knowledge of their parents, and sustain injury at such places, it must be attributed to mere accident that no care which they are obliged to observe, on the part of municipal authorities, could prevent." City of Chicago vs. Starr, 42 Ill. 175, was an action for injuries to a child from the falling of a counter standing on the sidewalk. It was held that the City was guilty of slight negligence, but that the negligence of the parents in allowing the child to be at large on the streets was such as to preclude any recovery. In City of Chicago vs. Hesing, 83 Ill. 204, it was held to be gross negligence on the part of the City to leave a ditch filled with water, about five feet deep, in a public and frequented street, bordering on a sidewalk, without any guards to prevent children from falling into the same, and if a child is drowned by falling into the same, the City will be liable. In such case a failure on the part of the parents to keep a constant watch over the child will not be imputed as negligence.—Ed.]

*Street Railway Tracks—Unreasonable Burden on Street—Injunction—Rights of Abutting Property Owners.*

Municipal corporations, when empowered by the legislature to do so, may devote a reasonable portion of the street to the use of a street railway without making compensation to the abutting owners, since such is a proper use of the street.

The legislature cannot devote the entire width of the street to railroad purposes unless compensation is first made to the abutting owner for the taking of his easements, though there be no constitutional restriction on the legislature.

Where a street is already incumbered with two street railway tracks, with a line of poles between, and in addition, with many electric light, telegraph and telephone poles on both sides of the street, an injunction will issue in favor of abutting owners against the construction of a third track and additional poles, though authorized by the City Council, since such a track is a special injury to the property rights of the abutters; it appearing that the tracks already in the street afford ample facilities to run all cars necessary for public convenience.

(Supreme Court of Utah. Dooly Block vs. Salt Lake Rapid Transit R. Co. 33 Pacific Reporter 229.)

*Collision with Wagon on Track—Injury to Passenger on Car.*

Where a motorman on a street car sees that a man driving a wagon along the track neither looks back nor pays any attention to the ringing of the bell, by increasing his speed or attempting to leave the track, it is his duty to bring his car under control, and the company is liable for injuries to a passenger if he continues until it is impossible for him to stop.

In an action by a passenger against a street railway company for personal injuries, received by a car running into a wagon on the track, the fact that the negligence of the driver of the wagon contributed to the injury, is no defence.

(Supreme Court of Washington. *Sears vs. Consolidated S. R. Co.*, 33 Pac. 389.)

*Elevated Railroad—Falling Sparks—Injury to Person in Street—Proximate Cause.*

By an unlawful act of a railroad company, fire was thrown upon a horse passing under the structure, so as to make him unmanageable, and by the same act the driver was so injured that, smarting from his injuries, he did not exercise judgment and skill in guiding the horse, and the plaintiff walking along the street was run over by the horse and wagon. *Held*, that the railroad company was liable to the plaintiff; that the damage was not so remote as to preclude recovery, since the chain of causation was not broken; that the mistake of judgment on the part of the driver, being caused by the defendant's unlawful act, could not be set up as an intervening cause.

(New York Court of Appeals. *Lowery vs. Manhattan R. Co.*, 99 N. Y. 158.)

*Removing Snow from Tracks—Making Street Dangerous—Injury by Upsetting of Sleigh.*

Where, in a suit against a street railway company, for personal injuries caused by the upsetting of a cutter while crossing defendant's track, the evidence showed that the snow which had fallen during the winter had been thrown up beside the track and trampled or beaten down so as to leave a depression at the track at a street crossing, of from six to ten inches or more, with a short slope downward; and that plaintiff's husband, who was driving, finding it necessary to cross the track at that point, turned the horse so as to cross as nearly as he could at right angles, but the sleigh, on making the descent, tipped over to the left and threw plaintiff out and injured her, these facts show negligence on the part of the company.

(Supreme Court of Michigan. *Laughlin vs. Street Railway Company of Grand Rapids*, 62 Mich. 220.)

*Car Running Backwards on Incline—Injury to Plaintiff's Team.*

The horses attached to a street car were unable to pull it from a ferry boat up the steep and slippery incline, and stopped part way up, and the car was held by the brake. An extra horse was usually in readiness to help pull cars up the drop, but, on this occasion, there was none, and the driver, after endeavoring to procure other horses, unfastened the brake and started his horses, which were

unable to pull up the car, and it began to run back. The driver applied the brake but could not stop the car, and it came upon the plaintiff's horses which were behind, attached to a wagon driven by plaintiff. The plaintiff had started from the boat as soon as the car was out of the way, his horses then being about ten feet back, and at the time the car began to run back, they were about twenty feet behind. The plaintiff backed as far as he could, but another team being behind him, he was unable to get out of the way, and the car came upon his horses and injured them. *Held*, that the case was properly submitted to the jury; there was evidence of due care on the part of the plaintiff; there was also strong evidence of the negligence of the defendant, both in omitting to have an additional horse to aid in pulling the car over the slope, as was usual under the circumstances, and also in the action of the driver in lifting his brake so as to permit the car to slide backwards. It was this negligence which was the proximate cause of the accident.

Massachusetts Supreme Judicial Court, *Cook v Metropolitan R. Co.* 98 Mass. 361.

**A COOL STEAM VALVE HAND-WHEEL.**

The familiar handle of the stove griddle lifter has been embodied in a steam valve hand wheel, made by W. F.

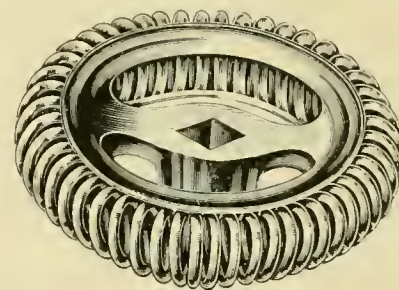

Greene, of Troy, N. Y. The circumference of this wheel is a continuous coil of steel wire. Having such a large radiating surface, it does not get hot as do solid metal ones, while being cheaper and

very much more durable than the wooden handles. The corrugated surface affords a good firm grip on the wheel.

**LONG DISTANCE TRANSMISSION OF STEAM.**

It is generally thought that of all methods, power transmission by steam is the most wasteful, but E. B. Cox cited an instance at the last annual meeting of the American Society of Mechanical Engineers, where at a coal mine, steam was carried 4,500 feet over a hill. The pipe was surrounded with mineral wool and laid in a trough made of two boards nailed together at right angles. On top of this another similar trough was laid, they were carried on stakes driven X-wise into the ground. At the pumping station, where it was used, a receiver made out of old boiler iron acted as a separator. Although a very cold climate, the arrangement has been in use since 1877 without any repairs. Mr. Cox says that the secret of success in steam transmission is in the receiver.

THE LEFFLER RAILWAY SYSTEM.

While most inventors have been at work trying to perfect a conduit system with which the ordinary railway motor can be used, P. W. Leffler, of 637 Monadnock block, Chicago, has attacked the problem in an entirely different way. His plan is to lay between the rails a series of magnets. These magnets attract magnets on the car. The arrangement of car and track magnets can be seen from the drawings. The conduit magnets are 6 inches high, 8 inches wide and 1 3/4 inches thick. They are mounted on an iron base plate and capped with a suitable iron lid to protect them from street traffic. They are cut into circuit in sections about nine feet long. The switch to do this is operated by the car. The magnet cores are nine inches between centers. The car magnets are excited by a storage battery through the medium of

the other two deliver it to the commutator proper, which has two rings each divided into four segments. There are three pairs of brushes, the relative positions of which are seen in Fig. 3. A plan view of commutator brushes

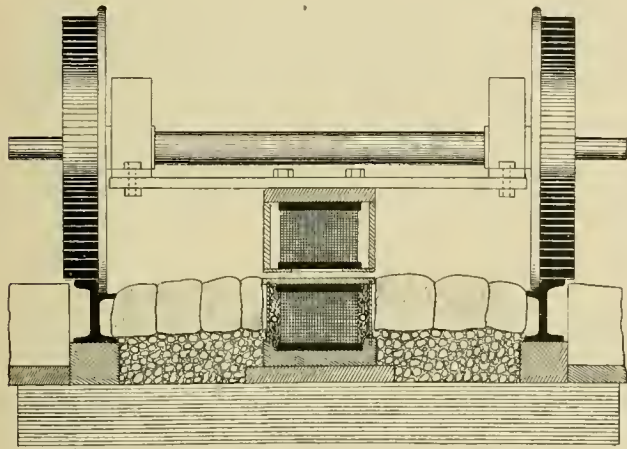

FIG. 1.—SECTION THROUGH CAR AND CONDUIT.

a commutator which changes their polarity as the car moves along, the action being almost identical with that in a synchronous alternating current motor in which the conduit magnets would constitute the fields and the car magnets the armature. The energy expended in the fields is higher and that in the armature lower than would be the case in an ordinary motor of the type mentioned. The car magnets are intended to run 3/4 inch above the conduit. The commutator, which is used to alternate

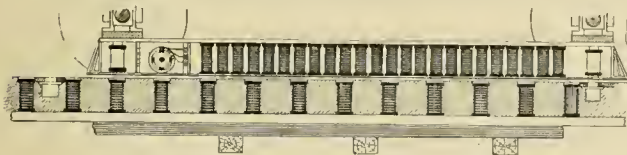

FIG. 11.—SIDE VIEW OF MAGNET SYSTEM.

the current in the car magnets, is made to revolve in synchronism with the motion of the car over the track magnets, by constructing it with four constantly excited poles as in Fig. 4. These poles are attracted to the opposite poles in the conduit and so the commutator is given a positive and synchronous motion. The current from the storage battery is led into the commutator through contact rings as in Fig. 5. Two of these rings take the current which excites the fields of the commutator and

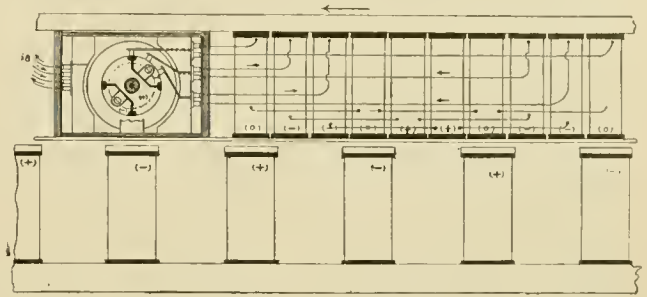

FIG. 13.—CONNECTIONS OF MAGNETS WITH COMMUTATOR,

and field magnet connections is shown in Fig. 5. When a pair of brushes passes from one pair of segments to the next, the current through the pair is reversed, and of course the magnets connected to them change polarity. Each pair of brushes is connected to every third magnet. Figure 3 represents a position in which one set of magnets is directly over the track magnets. The bushes connected to this set are accordingly on the insulating strip between segments and are out of circuit. The two other pairs of brushes

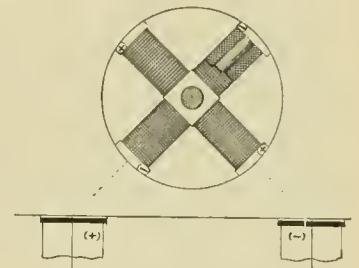

FIG. 14.—POLES OF COMMUTATOR.

are on the same pair of segments and their polarities are the same. A little study of the diagrams will make it plain how the polarity of magnets is changed so as to create a nearly constant horizontal effort on the car. As said before, the action is that of

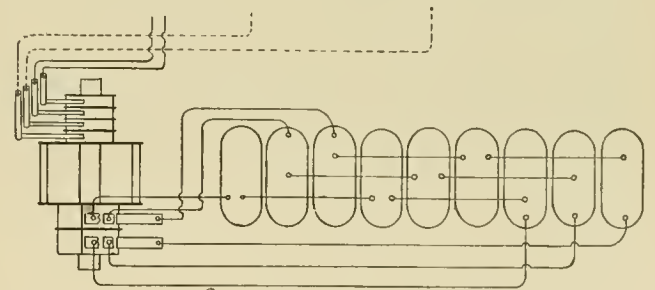

FIG. 15.—PLAN VIEW OF CAR MAGNETS.

an alternating current dynamo running as a motor. The braking power of the reversed motor is of course very powerful as it is independent of traction. The inventor's estimate of the cost of the conduit for one mile of single track is \$16,000. The repair of car magnets is, of course, much less than on a motor with revolving armature, and the mechanical losses on an ordinary motor are done away with. In fact, the combination of car and track magnets is nothing more or less than an alternating motor with strong fields, a wide air gap and very weak armature and slow inductor velocity.

## ELECTRICITY IN ANACONDA, MONTANA.

Electricity Unlimited, from Inexhaustible Water Power Flumed from the Mountains—Thousands of Tons of Icicles in Winter Present a Fantastic and Beautiful Picture.

The plants of the Electric Railway, Light & Power Company, of Anaconda, Montana, possess special interest for all who are compelled to generate power in localities where fuel is costly and water power can be obtained.

This company constitutes the electrical department of the Anaconda Mining Company, the greatest producer of copper in the world, whose immense smelting, concentrating and refining works are at Anaconda, a thriving city of 6,000 people, situated in the heart of the Rocky Mountains.

The company has two plants, both operated by water

house, and conducted thence by means of a wooden flume, which winds around the hills, and at the station is at an elevation of 142 feet above it. The flume is built of red fir, three inches in thickness, and its dimensions are five feet by five feet, with a fall of eight feet to the mile, which gives the water a velocity of 420 feet per minute, and carries a sufficient supply to develop 900 horse-power.

The flume crosses a number of ravines supported on trestles, one of which is shown. The ice at this point is the accumulation of the entire winter. The leakage amounts to little or nothing, not 1 per cent; and no ice whatever forms inside the flume even in the coldest weather, when the thermometer stands at from ten to thirty degrees below zero, sometimes for days at a time; but at several points leakage and water which splashes



"The water rushing madly down the flume, builds gigantic icicles."

power, the largest and most important of which is located a couple of miles up the valley from the town, and furnishes the incandescent lights of the city and the arc lights of the "Upper" works of the Anaconda Company. In addition to this, there is generated 650 electrical horse-power, which is transmitted three and a half miles down the valley to the electrolytic refinery, and there utilized in the refining of the copper as it comes from the converters. Here also is provided the power for operating the street railway of the city, which has five and one-half miles of track, including a line to the "Lower" works, some two miles below the city. This plant is operated solely by water power, and runs every hour in the year.

The source of supply is a mountain stream, from which the water is taken at a point three miles above the power

over the sides as it rushes madly down the flume, builds up gigantic icicles, which in the course of a few weeks depend in great stalactites, and later, reaching to the ground, stand like mighty pillars of purest ice, formed from the crystal waters of the mountain springs.

The lower end of the flume is connected with the power house by a steel pipe 4 feet in diameter and 650 feet long, which is divided on its entrance to the building into smaller pipes, each leading to one of the water wheels. The water after passing through the wheels is conveyed in a flume a half mile across the valley, and there emptied into the flume of the Lower Smelting Works and is again used to operate the second electric plant, located at the "Lower" works, four miles below.

The surplus water not required by this second plant is



THE CITY OF ANACONDA, MONTANA.

used in the different processes of concentrating and smelting the ore.

At the first and larger plant the water wheels consist of three Leffel horizontal shaft, double discharge, turbine wheels of 300-horse-power each, which are shown in the accompanying engraving.

There are also three Pelton wheels of 125 horse-power each, which are kept as reserve. The power house is a substantial structure of stone and brick, 60x130 feet.

The water wheels are in the basement and are belted of a 6-inch line shaft on the floor above, which in turn transmits its power by link belts to the dynamos.

The arc and incandescent machines are at one end, and also the Thomson-Houston railway generators operating the street railway. The refinery power is supplied by eight Edison 100 K. W. 500-volt generators, divided into

two systems of four machines. Each system has its four dynamos connected in series and runs at 2,000 volts pressure. The line consists of two positive and two negative wires of No. 0 copper for each system.

At the refinery, four 500-volt motors in series, receive the current of each system and transmit the power to low pressure Edison generators, which connect directly with electrolytic tanks.

The expense of operating this power plant is exceedingly low, two men only being required on each of the 12-hour shifts.

The price of coal is \$6.50 at Anaconda. This station has been in operation since 1891, and in six years from the time it was started will have repaid its entire cost in the saving it will have effected over the expense of operating a steam plant of the same size for that length of time.



LOWER SMELTING AND CONCENTRATING WORKS, ANACONDA.

The second plant of the company furnishes light only and is not run during the day time.

The water wheel here is a vertical shaft turbine of 325-horse-power, working under 15 pounds pressure, and drives the Westinghouse incandescent and the arc machines lighting the Lower and Upper works and the arc light machine of the city.

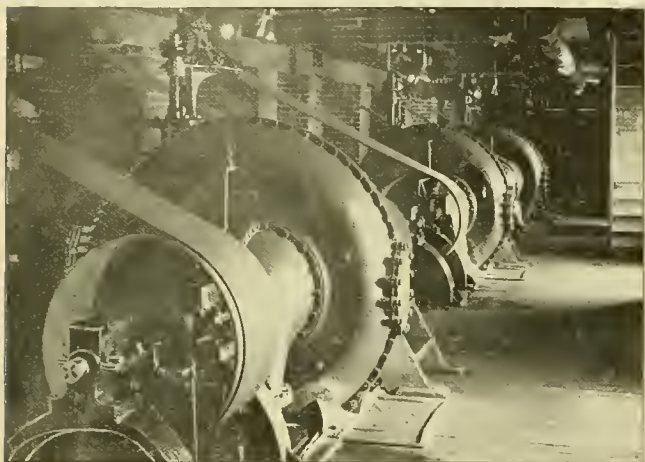

THE TURBINES.

The electric railway is one of the successful enterprises of this enterprising city, which bids fair in the near future to become the capital of the state. Notwithstanding the frequently severe weather incident to mountainous regions, the road is always kept in operation. During the summer a large created travel is induced to a beautiful park on the mountain side, at terminus of one of the lines, where the company frequently provides band music

THE GAYNOR TROLLEY BASE.

The accompanying engraving represents a trolley device, the invention of L. R. Gaynor, of Sioux City, Iowa. Its object is to put the trolley pole under the control of the motorman while he is on the front platform, and is for roads where there are no conductors. To the



GAYNOR TROLLEY BASE.

trolley base is attached a horizontal frame. It is attached above the swivel so that it turns as does the pole. The trolley rope is run over pulleys at each end of the frame so that is in reach of the motorman and he can pull down and adjust the trolley. To enable him to see the state of affairs, a mirror is provided at the end of the frame as shown.



INTERIOR VIEWS OF GENERATING STATION.

for the public. The energetic and very successful superintendent of the railway and lighting companies is Charles R. Holmes, formerly of Chicago, and one of the youngest street railway managers in the country. The road shows a constantly increasing revenue, while expenses are kept at a point not easily attained in many eastern cities, where labor and supplies cost much less than in Montana.

WHILE] the general press howls at street car horse cruelty, the Philadelphia Times gives a few sharp pointers to the omnibus companies, that allow their over burdened horses to strain and fall upon icy asphalt, for want of sharp caulks or rubber pads, both of which are cheap. The cruelty of buss and dray companies although not so much remarked is far more worthy of censure.

**NEW LOCOMOTIVE FOR NEW YORK ELEVATED.**

A Short History of "L" Improvement.—The New Engine.

In an article on the new locomotives for the Manhattan Elevated in New York, the Engineering News brings out some valuable historical points connected with the beginnings of elevated roads.

The first elevated line was in 1868, on Greenwich street, from the Bowery to Cortlandt street, and was operated by endless chains. This was extended to Thirtieth

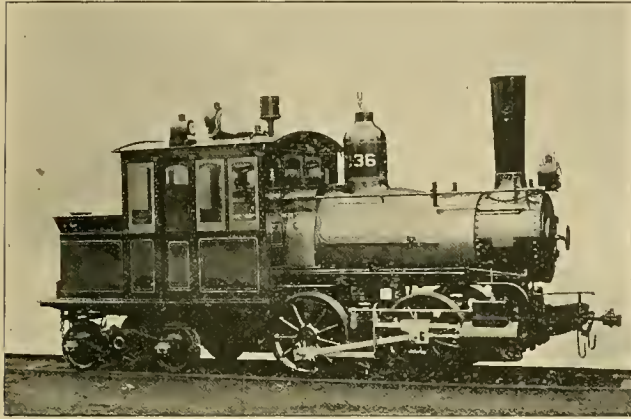

NEW L ENGINE FOR NEW YORK

street in 1870, but the chains proving a failure, were abandoned and small four-wheeled dummies substituted. These dummies carried saddle tanks on the boilers, the cylinders driving a crank axle between the main axles with connecting rods on the drive wheels. The ordinary train consisted of two cars of 11,000 pounds each, seating forty-eight passengers. The length of the trip was four miles and it was made in twenty minutes, including some seven stops. Late in 1871 the New York Elevated Railroad Company was organized, extending and improving the system. In 1877 a re-organization was effected and some large four-wheeled engines substituted, together with some of the Forney type. The Metropolitan was organized in 1876, operating double-end dummies of four drivers, and using leading and trailing pony trucks. The later ones were of the same type but with larger capacity of boiler and shorter cabs,

The Metropolitan now owns 311 engines of the Forney type and 1,090 passenger cars. Master Mechanic Peeples gives a table of dimensions showing the history of the development. The first engines weighed 12,000 on drivers, cylinders, 6 by 12; the double-enders weighed 35,310 on drivers, cylinders, 10 by 20 (time 1879); the Forneys of May, 1886, weighed 32,500, with cylinders 12 by 16 inches; the Forneys of 1894 weigh 33,000, with 12 by 16 cylinders.

Although two-cylinder and four-cylinder compounds have been introduced on Brooklyn and Chicago roads, the New York lines still adhere to the simple engine exclusively.

The latest engine is that built by Pittsburg Locomotive & Car Works of Pittsburg, Pa. These are designed to

haul five cars of 29,000 each, on a grade of 2.5 per cent at a maximum speed of 25 miles an hour. The builders' dimensions are as follows:

**RUNNING GEAR:** Diameter drive wheels, 3 feet 6 inches; truck wheels, 2 feet 2 inches.

**WHEEL BASE:** Driving, 5 feet; truck, 4 feet 8 inches; total, 16 feet 1 inch.

**WEIGHT IN WORKING ORDER:** On drivers, 33,000 pounds; on truck wheels, 14,000, engine, total, 47,000; full coal capacity, 16,00 pounds; water capacity of tank, 4,267; allowed for water in boiler, 4,000 pounds.

**CYLINDERS:** 12 by 16 inches; distance, center to center, 6 feet 4 inches; center to valve face, 10 $\frac{3}{8}$  inches; diameter piston rod, 2 $\frac{1}{8}$  inches; connecting rod, between centers, 5 feet.

**BOILER:** Type, extended wagon top; working steam pressure, 140 pounds; diameter of barrel, 3 feet 5 $\frac{1}{8}$  inches; heating surface of 183 tubes, 491 square feet (exterior).

The valve gear is link type, and Eames' vacuum brakes are used.

**STEAM ROAD PAVING TO T-RAIL.**

A substantial piece of paving to T rail in a paved street has been laid by the New York Central in the city of Syracuse, N. Y. A tram rail of special form is bolted to the T forming a tread for vehicles, and the stone blocks are brought up flush on either side of the iron, which is carried on cast-iron chairs 5 inches deep, and

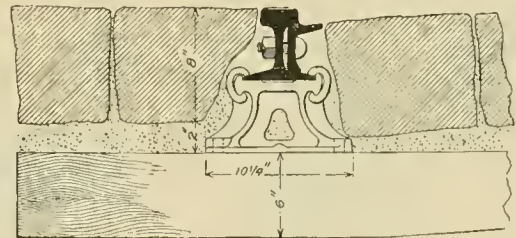

which, in turn, rest on the sleepers. The T is an 80-pound and the tram a 30-pound. This construction, exclusive of paving, cost \$13,498 per mile when laid, and could be duplicated to-day for about 7 per cent less. Our illustration is from the Railroad Gazette.

**THE NEW EXCUSE.**

In the ante-Trolley days  
 When some mysterious blaze  
 Destroyed the goodly "Clothing House"  
 Of the Moses-Aaron Co.,  
 With considerable fustian,  
 Spontaneous combustion  
 Would get the credit of the deed—  
 The others would Scott-free go.  
 But now, to be specific,  
 The cause of fires prolific,  
 When the companies insuring  
 Can't see that cause, you know,  
 They blame it on the current  
 Of the trolley — if it weren't,  
 Perhaps some one might hie him  
 To the penal, lost, Limbo.

EACH conductor and motorman of the Jamestown, N. Y., Street Railway Company has received as a gift, from some unknown friend, a neat pocket bible.

## BLOCK SIGNALS AT BUFFALO.

The Buffalo Railway is obliged at present to operate a small portion of one of its double track routes as a single track. The single track portion occupies two sides of a block, so that cars would be frequently meeting on the single track were it not for the block signal which has been installed. Two trolley wires are used for the single track, as shown in the general plan in Figure 1. This single track portion is separated by circuit breakers from the rest of the line. The signal boxes are connected in between the feeder and the trolley wire. When a car enters the block, the current which supplies

system was devised in the company's office, at the suggestion of H. H. Littell, general manager.

## SUNDAY SERVICE IN SCOTLAND.

The heading refers not to divine service, for faithful attendance upon which the sturdy Scotchman is noted, but to the more secular and week-a-day occupation of operating street cars on the Lord's day. Public agitation in the City of Glasgow has been quite active on the combined question of Sunday concerts in the City Halls and go-to-meeting trams. The concerts fared but poorly, and it has finally been left to the curator to designate the

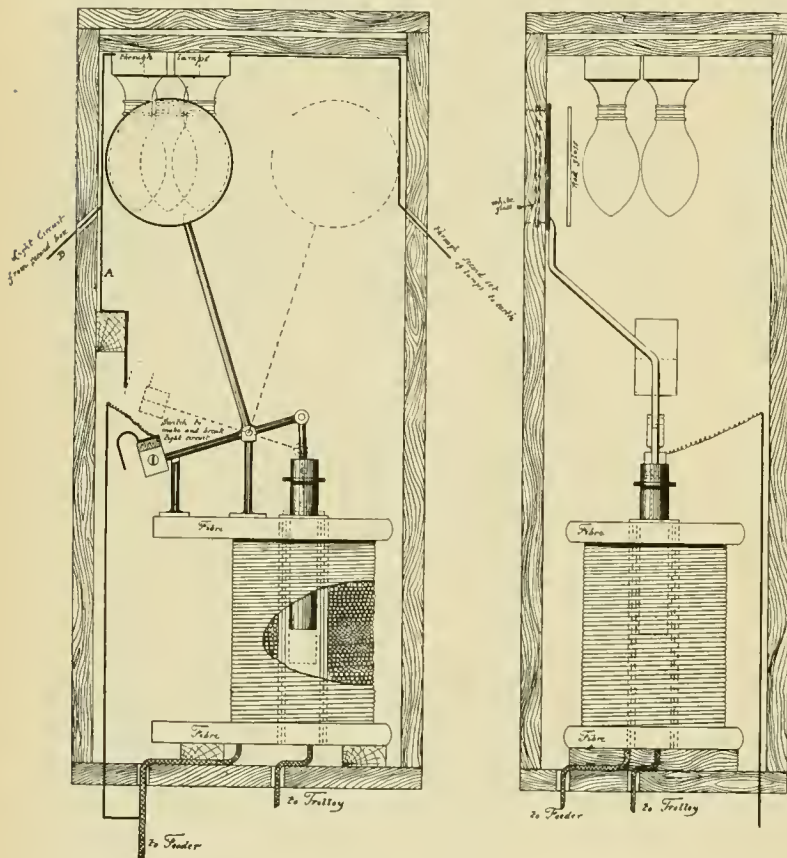

SIGNAL BOX.

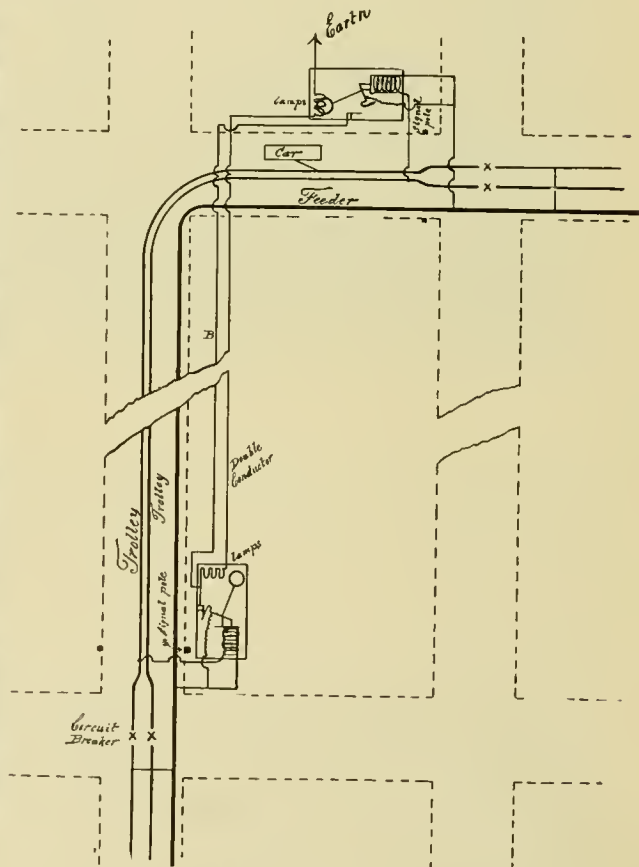

PLAN OF CIRCUITS.

the car must flow from the feeder through the signal box at the other end, thus giving cars going in the opposite direction warning that a car is on the block. The detail of the signal box is shown in Figure 2. The main trolley current flows around a solenoid of low resistance. The plunger of this solenoid operates the disc or shutter which discloses the lights at night, and by its color gives the day signals. The simplest way is to have these signal lights permanently in circuit. The most economical way is to have them cut in automatically, as shown here. This method has only one lamp circuit for the two signals. It would be simpler, of course, to have each bank of signal lamps independent, as then no wires other than the trolley and feed wires would be needed between the boxes, for the lamp circuit could be grounded at each box. The shutter is held to safety by a counterweight. The

good from the bad and to put his seal of approval on such as may be deemed within the limits of sacred service.

In this free country, free even to the extreme of error not infrequently, the occasion for an editorial of which the following is a part, from one of the leading Glasgow dailies, seems a good ways back toward the days of the Mayflower:

"While practically putting a ban upon the better sort of Sunday concerts, the majority have decided to give a modified tramway service on the Sabbath. But, after all, the Council could not have done less than this. Every practical consideration supports the continuance of some such Sunday vehicular convenience as now exists—indeed, the present service might be improved upon; and there are no moral considerations against it. Indeed, we may go further, and say that the ethical question, so far as it is involved in the matter, is all in favour of the policy of humanity. The doctrine that travel, change



of air, the meeting of friends are irreligious on Sunday is certainly inhuman, and, as the inhuman cannot possibly be divine, is assuredly not a providential ordinance. The working masses of this crowded city suffer enough, surely, from the too arbitrary recognition of this absurd and cruel decree in being, practically cribbed and cabined within the confines of Glasgow from Saturday night till Monday morning. To forbid, further, all movement within this too restricted area would probably serve as the last straw of convention laid upon the back of that long-suffering camel—the public. For, of course, coercion in such a matter would, in practice, have proved quite impossible. The Corporation car would no sooner have been taken off the streets than the omnibus of private enterprise would have made its advent, horrifying the over-zealous Sabbatarians by such noise and rattle as were never caused by the harmless, necessary tramway. The marvel is that 16 intelligent Town Councillors of Glasgow voted for a proposal so nonsensical.”

The Sunday car question is specially raised on a memorial bearing the names of some 120,000 Sunday-school teachers and scholars, and the Young Men's Christian Association. Some of the arguments are amusing to Americans. For instance, one speaker set forth that Sunday operation was introduced when the lines belong to a corporation for the benefit of stockholders, and now the road was owned by the city few but the wealthy cared to use the cars Sunday. Then he adds a little later—“The traffic on the Lord's Day has grown to such an extent that the streets literally swarm with cars,” which would indicate there are few poor people in Glasgow. Another backed (?) his argument for cessation of cars on the ground that as fast as they gave facilities the traffic increased,” while another more sensibly remonstrated with the statement “To attempt to stop all Sunday traffic would be like trying to sweep back the Atlantic with Mrs. Partington's broom.” It was finally decided by a vote of 32 to 16 to continue the Sunday car service and the storm is quelled, at least for a time.

THE DARRACH FENDER.

S. A. Darrach, of Newark, N. J., has invented a fender which he is not afraid to try on himself and which has

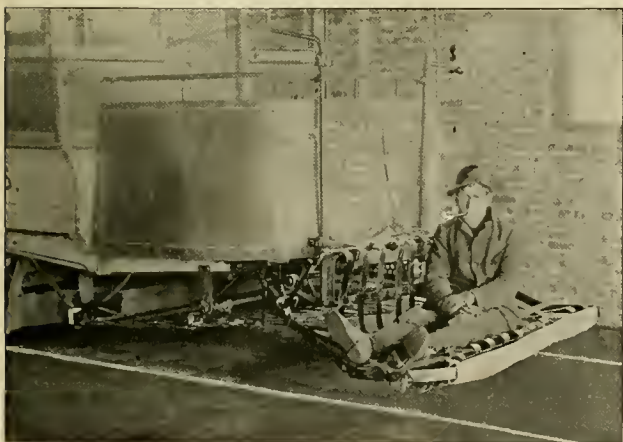

proved its efficiency by picking up Mr. Darrach in numerous trials. Although he is an elderly gentleman, as will be seen from the engraving, in which he is shown

under the fender, he sustained no injury in the dozen or more times he was picked up. The fender is a light frame of steel pipe, supporting the cushion of flat steel springs, which take the place of the wire netting usually employed. If a person is lying on the track the fender passes over him and a scoop under the car body in front of the wheels is automatically lowered to receive the body. But very little weight rests on the person passing

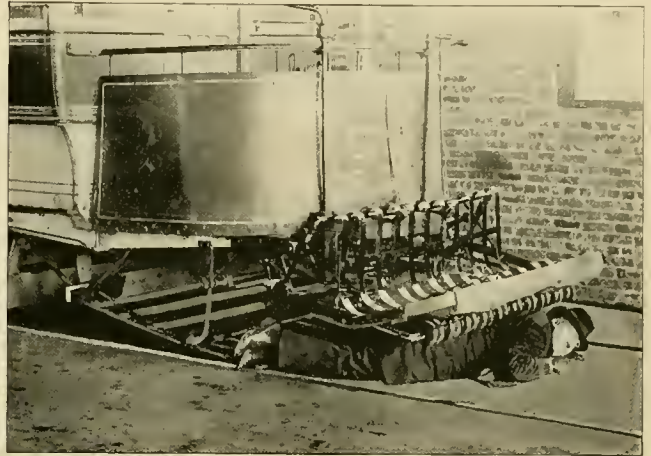

MR. DARRACH DEMONSTRATING HIS FENDER.

under the fender. The prime object of the fender however is to rescue people who are on their feet at the time the car strikes them. For this purpose the flat steel springs are well suited, arranged as they are, to protect the person from striking the dashboard or sills. The trial at Newark recently was very satisfactory. We understand that Mr. Darrach is at work on a fender which does not extend beyond the car dash.

MEAKER REGISTERS FOR CHICAGO CITY RAILWAY.

The Meaker Manufacturing Company, of Chicago, whose portable fare registers have been exclusively in use the past ten years on all the lines of the Chicago City Railway, has just closed a new contract with that road. The fact that the former contract was to expire was known to all the register companies and the result was a decidedly lively fight to secure the new contract, and in this connection the report became general that the road was about to discontinue portables and adopt stationary registers. Hence the new contract for continued use of the Meaker portable register, which was closed March 1, is not only highly complimentary to the excellence of the Meaker machines, but may also be properly termed a very large compliment, inasmuch as the City Railway uses 1,600 of these registers.

A COWARDLY attempt was made, February 24, to burn the repair shops of the Brooklyn, N. Y., Elevated Railway Company. It was the second such attempt, and cost the company \$3,000. Discharged employes are suspected of the deed.

## CROSBY &amp; REITMEYER CONDUIT.

This conduit is similar to a cable conduit in construction, except as regards shape and depth. It is five feet deep from the top of the slot rails and three feet wide. The sections given here show the details. Although a

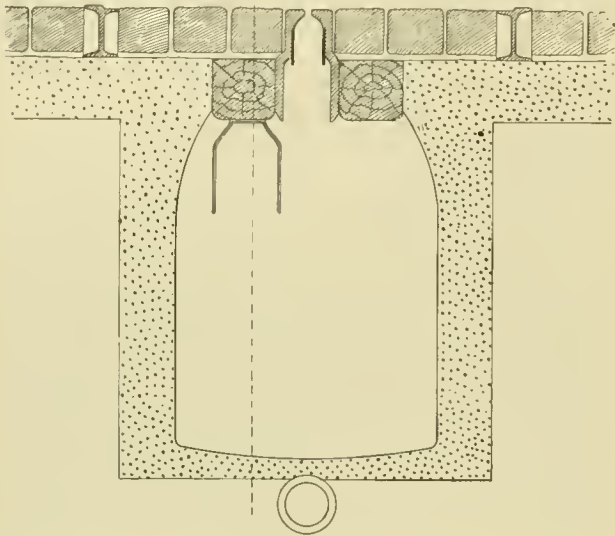

CROSS SECTION AT YOKE.

single trolley system, the double trolley arm is used to facilitate operating on Ys and turnouts. The trolley wire is protected along its entire length with a hood of sheet iron lined with vulcabeston. The trolley hangers are

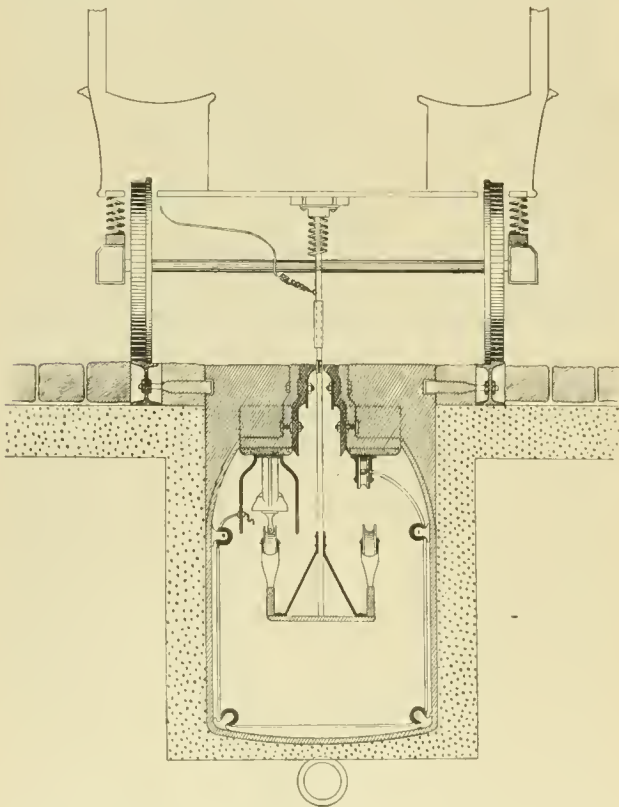

CROSS SECTION SHOWING TROLLEY CONTACT

supported from timbers extending along the slot rail inside the conduit. The inventors have given a great deal of attention to the trolley arm. Side motion of car is allowed

for by a socket in the iron plate where the arm is attached to the car. The spring holding up the device has play of only about three inches, so that no harm comes to the trolley if it does come off, and the difficulties of switches and turnouts are reduced to a minimum.

## PLEASURE RESORTS AND CREATED TRAVEL.

## PART IV.

It is often a matter of surprise to the uninitiated that the roads in the smaller towns carry such a comparatively enormous number of people to their pleasure resorts. We have shown that this traffic can be induced in nearly every town large enough to support a street railway, and that the results are something surprising, even to the managers themselves. There is a difference between cities in this respect, but it can generally be noticed that where there is a great deal of pleasure riding it is directly the result of an effort on the part of the street railway management. A road noted for the number of its pleasure riders is the Citizens Street Railway, of

KALAMAZOO, MICH.

Kalamazoo is conceded to be one of the most beautiful cities in the United States. The road consists of eleven



miles of track, equipped with 48-pound T-rail, laid on oak ties, 2-foot centers. The roadbed was put in in the most substantial manner. All of the turn-outs, switches, crossings and special work was made by the Page Iron Works, of Chicago. Through the business portion of the city iron center pole construction is used. The remainder of the line is of side pole, span wire construction. The overhead line has been built in a most modern and substantial manner. The company is operating thirteen double motor cars, 16-foot bodies, built by the St. Louis Car Company, and during the summer months operate in addition to these motor cars, twelve trail cars, making twenty-five cars in all. The motors are all General Electric single reduction, on St. Louis trucks. The road is operated by four 80-horse-power General Electric rail-

way generators, which are driven by a 450-horse-power Lane & Bodley corliss engine. The railway company owns and controls a beautiful piece of property, situated 2½ miles from the center of the city, which is known as Lake View Park. This property consists of about ninety-three acres of land and water, the lake being about one-quarter mile wide and one-quarter mile long. The grounds are provided with dancing pavilions, band stands, restaurants, check house, and a large boat house, and upon the lake are twenty-five 14-foot row boats, two electric launches, and one steam launch. During the summer months, attractions, such as balloon ascensions, tight rope walking, swimming matches, fire works, band and orchestra concerts are given, and are attended by large crowds. On Sundays a religious service is held in the afternoon, and with music in the evening, and it taxes the rolling stock of the railway to carry the people back and forth. The lines of road radiate from the center of the city, all crossing a given point, and at which point the transfer station is established and transfers given to passengers from one line to another. This company was the first to introduce the "aluminium ticket." They are sold at the rate of six for a quarter for adult tickets and ten for a quarter for children's

the largest producer of celery and has a large number of very fine public, state, county and city buildings. The engraving which shows the people getting in line to board the cars, was taken on a circus day last summer, on which day 12,000 people were carried, or more than one-half the attendance at the circus.



STANDING IN LINE.

## UTICA PARK, ON THE UTICA & MOHAWK.

The popularity of President James T. Mann's resort can best be judged by a few words, quotation from the *Globe* of Utica.

"In this lovely Mohawk valley few more delightful spots can be found than that one which in so brief a time has become such a favorite—Utica Park. Nature and man (or Mann, if you like it better that way), have labored together to make the place attractive and the large crowds which daily visits there are better evidence than any words could be that they have been successful. Within three years they have transformed a wild woods and rough pasture land into a garden spot of beauty and made it the

finest picnic park in central New York."

The park is about two miles from the center of the city and comprises 70 acres, half of which is woodland. One of the first things to attract the visitors' attention on



LAKE VIEW PARK, KALAMAZOO.

tickets. These tickets are on sale at the most prominent stores throughout the city.

Kalamazoo is a very enterprising city, having a population of about 30,000 people and has some of the largest manufacturing interests in the world. It is also noted as

entering the park, is the "zoo," a neat structure, where are the quarters of animals, too numerous to name, and which are always a drawing card. Then there is, of course, the dancing and refreshment pavilion and the neat little waiting room at the park entrance.

## A McKEESPORT ROAD.

Electricity Surmounts the Difficulties of Grades and Curves.—Doing a Steam Road Business—Mail, Freight and Express.

The peculiar topography of that part of Allegheny county (Pennsylvania), near Wilmerding, caused that city and the main line of the Pennsylvania railroad to be separated from McKeesport with its two navigable rivers, its four trunk lines of railroads, its large industries and 40,000 population, by an elevation less than two miles by a direct line, but 1,200 feet high, and the contours of which proved for years an insurmountable obstacle to skillful engineers who, fully appreciating the importance of the narrow link, endeavored to discover a grade which would permit a steam road to be run from the main line of the Pennsylvania railroad to McKeesport.

This was before electric traction had been so fully exploited and before engineers knew that the electric cars could climb a grade.



POWER AND CAR HOUSE.

Engineers made many surveys, and plans covering almost every inch of the intervening ground and even the complete details of a tunnel had been prepared which was to pierce this troublesome eminence, and to cement, in an intimate commercial union, the large interests of the two sections, that were so near yet seemingly so far.

Readers of the REVIEW will no doubt remember that the early numbers of 1892 chronicled the organization of the McKeesport & Wilmerding Railway Company for purpose of constructing an electric road over this ridge to connect the two places. The enterprise was viewed with much suspicion. While all admitted what an important profitable link such a railroad would be, if finished, the majority doubted that it could be successfully operated.

Taylor, Romine & Scott, of McKeesport, Pa., were the engineers of the road, and worked industriously for almost one year surveying the ground and locating the road at the shortest possible distance and with the easiest grade, and those who now ride over the line will appreciate that the firm has distinguished itself, has largely

subdued the elevation between McKeesport and Wilmerding, and traffic between the two places can be conducted on a comparatively easy grade. The road is a trifle over four miles long from the end of Fifth avenue, McKeesport, and the Pennsylvania railroad depot, Wilmerding, Pa., and is equipped in a superior manner, heavy rails and a splendid roadbed were secured, poles and



REVERSE CURVE, ELEVEN PER CENT GRADE.

overhead work are of the latest design and of the most substantial character. A special rail brake for emergency guards against accidents on grades.

The power house of the company is located about midway on the line, and both the power house and car barn are built of iron. The fuel is supplied from a mine adjoining the power house and owned by the company. The power house has two Pierpoint boilers of 100 horsepower each, Russell engine of 250 horse-power, and one Westinghouse dynamo of 150 horse-power. The cars of the company are supplied with two 25-horse-power Westinghouse motors.

By electric cars the McKeesport & Wilmerding road connects at McKeesport with the McKeesport & Reynoldston Passenger Railway Company, which, at River-ton, joins the White Traction Company, now running through Duquesne and which will be extended to Home-



ONE THOUSAND FEET ABOVE TERMINI OF LINE.

stead. The Wilmerding end of the road connects with the Second avenue line, which extends from Market street, Pittsburg, along Second avenue to Glenwood, Braddock and Wilmerding, and the McKeesport & Wil-

merging railway is a link which makes it possible to ride on electric cars from McKeesport to Pittsburg, a distance of twenty miles.

The road was built in less than four months, and was opened June 3, 1893, and, at the close of the six months' business, December 1, it was found that over 93,000

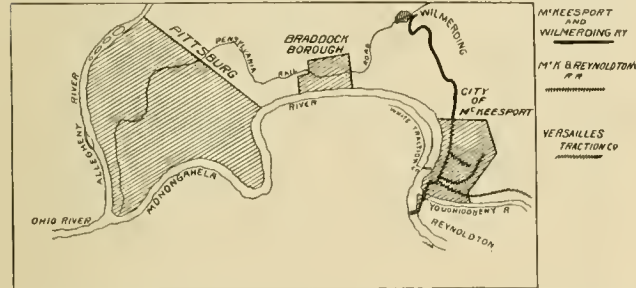

passengers had been carried in 150 days. There has been no accident of any kind and, although containing a number of 11 per cent grades, no "tie-ups" are reported on account of snow and ice.

The road, on November 6, 1893, began carrying all the mails for McKeesport and for points up the Monongahela and Youghiogheny valleys and the Adams Express goods for the same routes. This route saves twenty-nine miles, as the mail and express was previously carried fourteen miles from Wilmerding to Pittsburg and fifteen miles from Pittsburg to McKeesport.

The freight service is conducted in the most complete form, with specially constructed cars. The cars are

companies, and in handling fifty-foot drops and other long scenery two small trucks, coupled the requisite distance apart, are used. A combination car leaves either end of the line every hour from 6 a. m. to 12 p. m., carrying mail, express and freight.

The mail service is under the post office department, and conveys pouch mail between McKeesport and Wil-

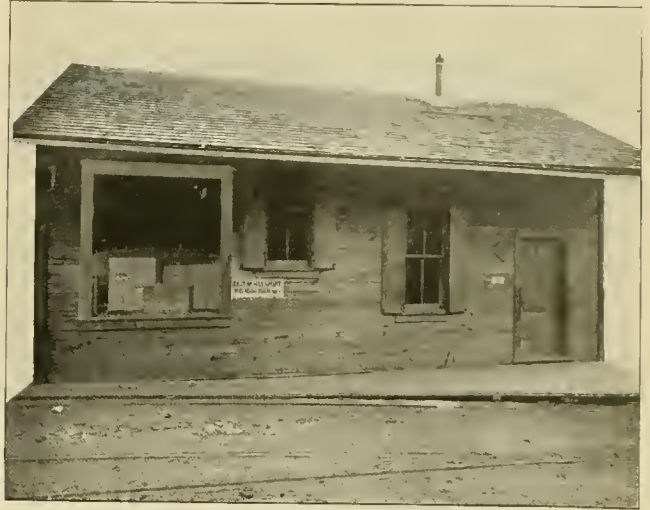

MCKEESPORT DEPOT.

merding. The mail is delivered from the station to the post office in a light wagon and is not sorted en route. The government pays so much per mile per hundred pounds. The time of transit from the depot at Wilmerding to the McKeesport post office is forty minutes.

One feature of the mail service is the delivery of Pittsburg Sunday papers in McKeesport. Formerly, by B. & O. rail the Sunday journals arrived at 9 a. m. The Pittsburg Leader, however, created a sensation by



WILMERDING SHOWING LINE ON HILL ONE THOUSAND FEET HIGH.

twenty feet long, of which five feet is separated from the passenger portion by a partition in which there is a door. Mail, express and freight are carried in this space; doors at the side of the car permit the largest trunks or packing cases to be taken in or out. When freight is of too heavy a nature or in quantities too large to be taken in this combination car, the company has a plain box car which is used as a trailer, and in which baled hay, lumber, household furniture, and freight of such a nature is transferred. The combination car is frequently used for funerals, the casket being placed in the express portion and mourners and friends in the passenger portion. The company is called upon frequently to transfer theatrical



CONSTRUCTING THE LINE.

chartering a car over the electric road and bringing papers thus from the Pennsylvania railroad junction at Wilmerding to McKeesport by 7 a. m. The Leader was justly proud of this enterprise, and spoke editorially of the splendid electric service.

The freight, mail and express business over the McKeesport and Wilmerding road is controlled by the



## MAMMOTH SNOW PLOW AT MINNEAPOLIS.

During the past winter what is probably the largest and most effective snow plow ever run on a street railway has been in use on the Twin City Rapid Transit Company's lines, at Minneapolis and St. Paul. In its construction, the well known but poorly acted upon principle is recognized, that to successfully fight snow something more must be done than to merely shove it to one side of the track. Piling the snow up on either side simply invites that subsequently falling, to drift deeper than ever. It also invites teamsters to take to the track and stay there. It is, in addition, important that the snow cleaning apparatus should be independent of the car movement in its action: This latter principle has been made use of in

are of  $\frac{5}{16}$ -inch steel, and are riveted to endless sprocket chains running on rollers. The front conveyor drops the snow on to a side conveyor, which is thirty inches long, and throws the snow out at the side of the car, where it is taken care of by the wings. The side wings have a fifteen foot sweep, and are two in number; the smaller one in the front to start heavy banks and to keep snow away from the plow, and a larger one behind it to do most of the sweeping. The front wing is a simple  $\frac{5}{8}$ -inch steel plate 4x6 feet, rigidly pivoted to the snow plow frame, and backed up by a channel iron beam eight feet long. The rear wing is made of two 60-pound steel T-rails, fifteen feet long, bolted at the top and bottom of a 4x15-foot plate of  $\frac{1}{2}$ -inch steel. It is a floating wing, having no rigid connection to the plow frame, and being

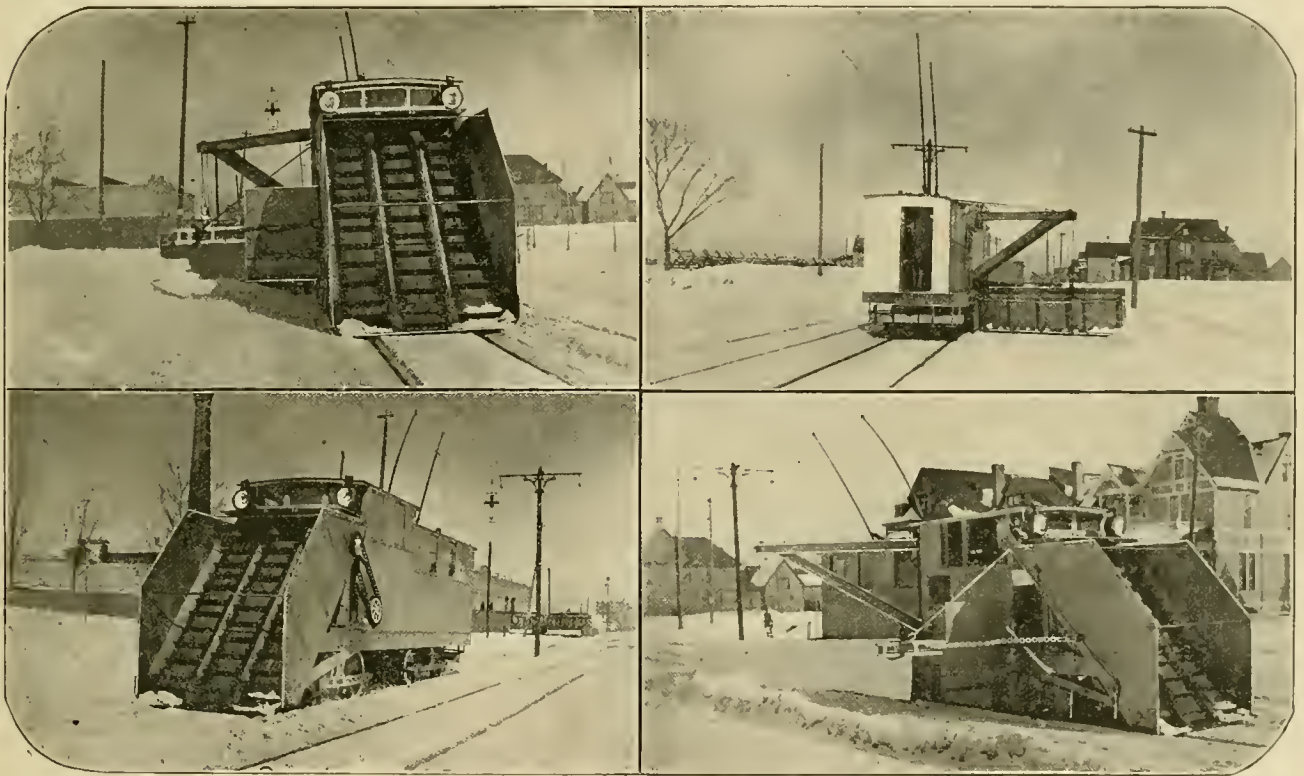

THE MINNEAPOLIS MOGUL ELECTRIC PLOW

sweepers having the brushes independently driven, and which give excellent results. The Minneapolis plow, however, by the use of conveyors instead of brushes, disposes of a much larger quantity of snow in a more satisfactory way. The power required is, of course, enormous, but on a large system this is of only secondary importance, the main point being to do the work without delay. To remove the snow from the track, the scheme adopted on this plow is to raise the snow in front of the plow by means of conveyors. It is then dropped on a short cross conveyor, which throws it to one side. Heavy wings push back the snow coming from the conveyor, and in addition clear the roadway at the side. The front conveyor is nine feet long, and placed at an angle of forty-five degrees. The blades of the conveyor are sixty-six in number, having dimensions 24x6 inches. They

elevated and carried by a jib crane. The crane is made of 8-inch channel iron, its height and length being, respectively, seven feet and twelve feet. It is supported at both ends by  $\frac{1}{2}$ -inch steel rope running over pulleys, in several turns. This wing, which is considered the most important feature of the plow, has a weight of 3,500 pounds. Inside of the plow are six redesigned Number 6 Sprague motors, which, after a 9 to 1 gearing reduction, are connected to a heavy 26-foot shaft. These motors supply power to the conveyors by means of an ordinary chain and sprocket wheel. By means of clutches these motors also supply power to adjust the height and sweep of the heavy 15-foot wing, which may thus be quickly taken from a 15-foot sweep, and folded in its "pocket" at the side of the plow. The steel ropes which change the position of this wing run over drums

which receive their power from the motors by means of worm gearing. Each pair of Sprague motors has a controller and reversing switch.

The plow is mounted on two strengthened Bemis pivotal trucks, having 7-foot 6-inch wheel bases and 20-foot pivotal centers, giving a total wheel base of 27 feet 6 inches. Allen paper 33-inch wheels and  $3\frac{3}{4}$ -inch axles are used. Each truck is equipped with two W. P. motors, redesigned for great torque and slow speed. The horizontal effort exerted by each motor at 100 amperes with the 4.78 gearing reduction and 33-inch wheels, is 1,650 pounds or 6,600 pounds from the two trucks. The two motors on each truck are governed by a series multiple rheostat switch, such as is used on the company's cars. The clutches controlling the rear wing, and the handles governing the controllers for the six Sprague and the four W. P. motors with their reversing switches, cut-outs, etc., are conveniently placed near the upper part of

#### NATIONAL ELECTRIC LIGHT CONVENTION.

An uninformed visitor to the National Electric Light Association, held at Washington, from February 27 to March 2, might, during one of the sessions, easily have thought himself at a street railway convention. We refer to the reading of the paper on "A Complete Metallic Circuit for Street Railways," by J. H. Vail, and the discussion which followed: Mr. Vail's paper brought out no new points on this subject, being valuable chiefly as a concise review of the matter in hand. The value of the rails as conductors, as against supplementary wires, and the importance of large bonds was well illustrated by both figures and diagrams. Indeed, after showing the absurdity of using copper conductors of ordinary size alongside the rails, it was rather surprising to see him lay so much emphasis on the importance of track feeders to various points of the system, which feeders, according

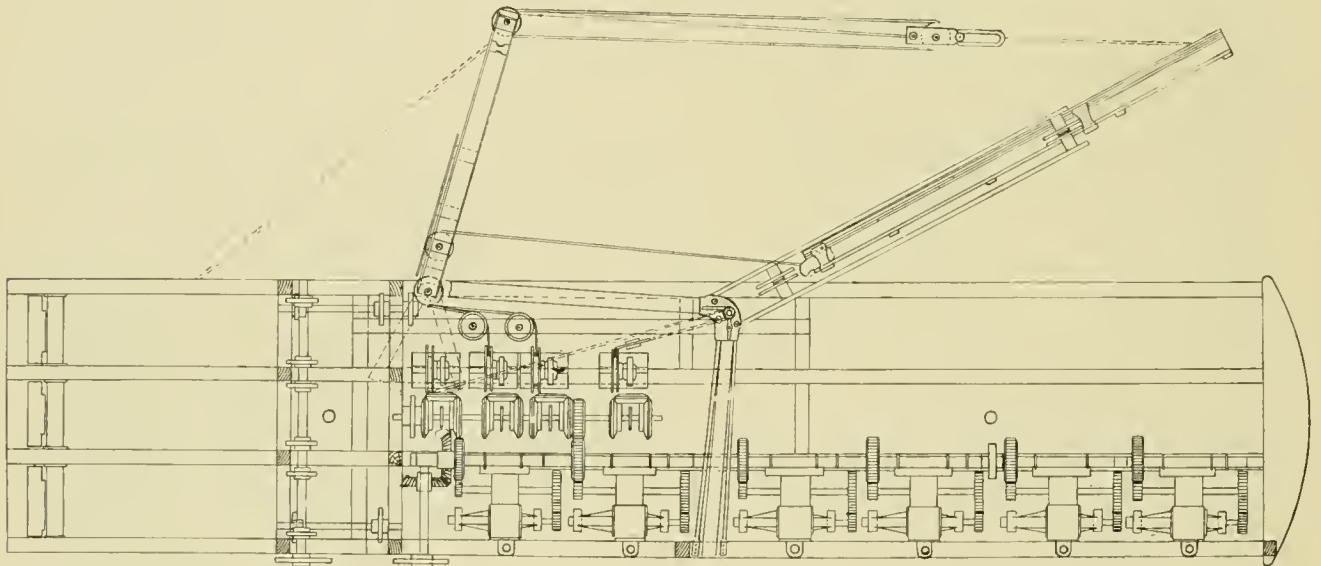

PLAN OF SNOW PLOW.

the front end of the plow. On account of the drop in potential at the end of some lines, it was found impossible at times to estimate the current used by noting the speed of the plow, but by noticing a large dial ammeter the motors are kept from working too long above their capacity. In order to avoid the sputtering at the trolley wheel, with heavy currents, and the risk of burning off the overhead wire should the trolley come off, two trolleys are used. The length of the plow is 39 feet, and its weight 35 tons. It was designed and built by the engineers of the Twin City Rapid Transit Company, at its Minneapolis shops. It is built after designs on which the Railway Track Cleaner Company of Minneapolis, of which company Thomas J. Canney is president, owns the patent.

A big car factory is reported to be established at Seattle, Wash. The plant to be established on Salmon Bay, at a place called Ballard.

to his own statements, must be of enormous size to be of any value as compared to the rails. However, the specifications made by him for the construction of a ground return are in general good, and can be carried out in practice with the best of results. An extensive discussion followed, in which several street railway men took part. C. W. Wason, of Cleveland, spoke of

#### THE CONTINUOUS RAIL,

and said that in conversation with President Moxham, of the Johnson Company, he was assured that the company would guarantee perfect work from a welding point of view. The company had been rather discouraged with the work done on the West End, at Boston, where the joints were made by welding the fish plates to the rail ends, but being urged on they had continued their experiments with more success. In the welding done now, the rails were simply butted together and the weld made at the ends. They have contracts for welding 150



miles of track during the coming season. Two welding machines have been ordered in addition to the two they now have. Mr. Wason stated that the 1,000 feet of track he had laid with hot riveted joints still remained in good condition. Mr. Smith also referred to an instance under his notice where a mile of track was so riveted and the expansion was not noticeable.

RAPID TRANSIT IN NEW YORK.

A Solution of the Problem that is Highly Effective and Comparatively Inexpensive.

New York City has for a long time occupied itself with the much vexed question of increased transportation facilities. The elevated roads at first bettered conditions by adding first more trains and later more cars to a train, until the limit was reached. Then the surface road installed cable, and offered great relief to the short-haul

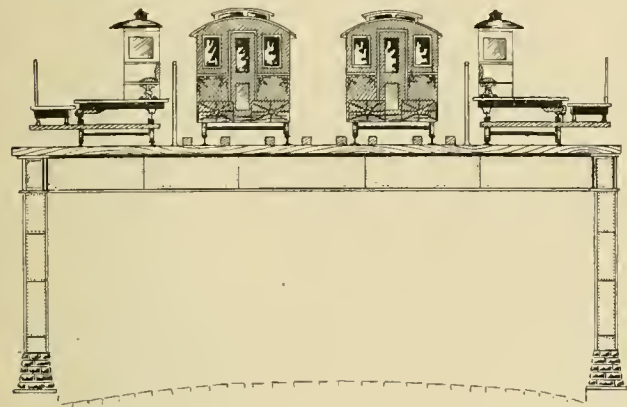

SINGLE DECK PLAN.

riders, but the continued growth of the city has brought matters to a point where radical additional facilities must be provided. Underground systems have attracted much attention, but it is doubtful if any relief can be expected for years from this source. The very unsatisfactory results of the operation of such systems in London,

operate trains of the same weight and at the same speed as at present, unless the second story is placed on independent supports.

Gen. Herman Haupt, an engineer of national reputation, has shown that during busy hours the headway is 1 1/2 minutes, which with present facilities gives a seating capacity of only 7,852 each way per hour. Speed can-

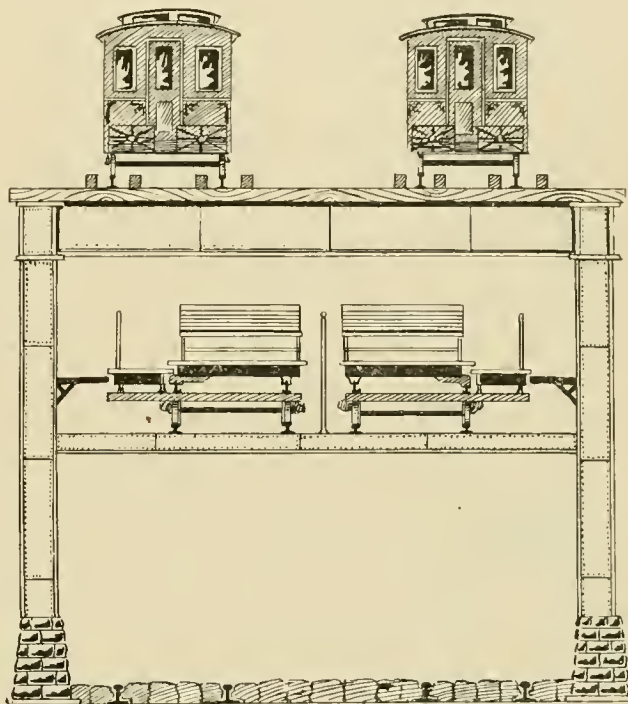

DOUBLE DECK PLAN.

not be any further increased without a corresponding decrease in headway on account of danger, so what would be gained in speed is more than lost in reduced number of cars. To carry 150,000 per hour would therefore require no less than fifteen of present double tracks and equipment. Prominent engineers in New York are much attracted by the proposed solution of all the troubles by adopting the moving sidewalk system in conjunction

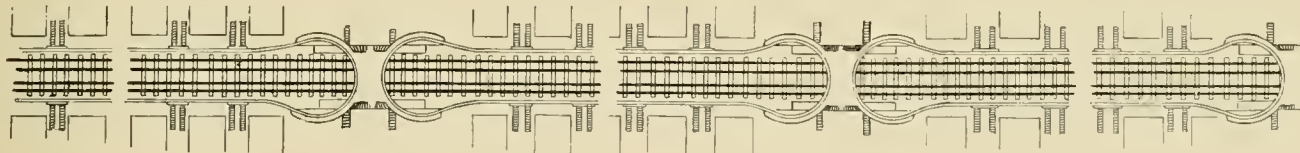

PLAN SHOWING LOOPS AT ONE MILE SECTIONS.

coupled with the immense expense of their construction and the length of time necessary to get them in operation, militate against them to such an extent as to almost prohibit their further application. The ideal method is, to so increase the facilities of the elevated roads already built as to largely increase their capacity. As these lines already operate along the great arteries of public travel, this would be much more desirable than to construct additional parallel lines, if indeed such were possible. The present elevated structures are not of sufficient strength to admit of placing a second story, on which to

with the present service, and by this means reducing the number of stations at which express trains would be required to stop, and in that way securing the increased speed not now possible with frequent stops. Stations for taking the cars could then be established, say at intervals of one mile, to which passengers would be delivered from the moving sidewalk, which in turn could receive at every block if desired, as no stops are made. Two methods of using the sidewalk are being considered. Both provide for one mile sections, with connecting loops at the express stations. It is understood that the turn in

the narrow space of a street is perfectly feasible, a radius of thirty-five feet having been adopted for the network of elevated moving sidewalks proposed for the business district of Chicago. Both plans are illustrated. One is to put the steam trains overhead, which has the advantage of providing covering, at no additional expense, for the moving sidewalk below. The other is to run it outside the present tracks, at the same level, except at the loops, where it crosses the express stations overhead. The Multiple Speed & Traction Company, of Chicago, controls the moving sidewalk system, and operated it with great success at the World's Fair, where it carried over a million passengers. It seems unquestionable that the addition of the moving sidewalk to the elevated roads, as explained herein, would solve the rapid transit problem for many years to come, and do it at the least expense. Everything favors the adoption of the plan, which has been fully demonstrated as effective, economical, reliable and of almost unlimited carrying capacity.

### AN ELECTRIC LIE.



VERACIOUS motorman from Brooklyn was visiting Mr. Mulvaney, who twists the juice on a North Shore car, Chicago.

"It was jist this way," said the veracious, "me an' Bill had took our car out and was running a fair gate down Mosquito Hill, (that was when I was on a Jersey line). The

bridge across Mosquito Creek was gone. 'Them Hopkins kids again,' says Bill. 'They've took the bridge down to build a raft, and now how in Podunk are we goin' ter git across that kassim?' "I don't know nothing about kassums, Bill," says I, "but we'll git across I'll bet."

"We wus jist a quarter of a mile away and the grade wus pretty stiff and we wus goin' down bent to fer election. A nervous old lady says to Bill, 'Mr. Conductor, won't you let me out 'fore we get to the bridge?' 'Yes-sum,' says Bill. He onct was a barn boss and is an awful liar, 'jist as soon as we gits to it I'll tell youse.'"

"In the meantime we wus sailin'." I turned on all the juice and ler'er go Gallagher. We struck the level with a bang, and may I drive a bob-tail all my life, if that bloomin' car didn't raise clear across the creek and land plump on the rails on the other side. We broke the trolley pole, so Bill had to take the switch hook and be trolley-pole the rest of the way to Mud Flats."

"It were a great trip!"

Mulvaney was staggered for exactly thirty seconds.

Then he shifted his quid and remarked, "That was purty good aim youse had to hit the other track, but it aint a circumstance to a little speed of mine when I was gripman on the Chicago City."

"Some movin chaps was puttin' a house acrost the tracks when their rope and wid'lass broke and there she stood plump in the middle of both tracks, I was going south just below Forty-seventh on State. I seen the

house there and knew that the old man would'nt take no excuses on the rush trip, so I says to me conductor, wot will we do? "Do!" says he "Do! Why we'll stay here and wait for the wagging."

"We'll do nothin' of that kind," says I, "we'll percede with the amoosement."

"An' we perceded."

"I jammed the lever over hard and let'er flicker. We was at that time tree blocks away and I got up some push on the bloody string, I'm tellin' youse. We struck the house on one side, somethin' gav and before anybody knew it we was comin' out on the other side wid a purty a hole as ye ever see bored plum troo dat house. It scratched some paint off and that ongrateful company called it foolhardy so I'm twistin' lightnin' now. Jest lend me a chau of yer plug will youse?"

### MR. WYMAN GOES TO MILWAUKEE.

C. Densmore Wyman, whose genial and warm hearted manner have long since endeared him to the members of the street railway fraternity, in whose estimation also he stands equally high as a manager of unusual executive ability, has accepted the position of general manager of the consolidated lines in Milwaukee, and has already entered on his duties. Mr. Payne, who has so long and successfully carried the responsibilities of both a vice-president doing the work of president and general manager, with all its details, has for some time felt the necessity of being relieved of a part of the double burden, and upon his becoming receiver for the Northern Pacific Railroad the load became unbearable. Mr. Payne will therefore be as closely as ever associated with street railway interests, and the West regains a valued and honored member.

Mr. Wyman was born at Racine, Wis., in 1850, but removed with his widowed mother to New York at an early age. Here he gained the most of his education. One year was spent at the University of Rochester, but Chicago University claimed him, and in 1872 he was graduated from the latter institution with honors. The same year he became the private secretary of G. Hilton Scribner. Afterwards, he was graduated B. L. from the Union University, and was admitted to practice. In 1874 he was elected secretary of the Central Park, North & East River Railway, of New York, the "Belt" line. Since then, until 1893, Mr. Wyman has been exclusively in telegraph and railway work, making a brilliant record. In the Columbian year Mr. Wyman was made general manager of the electric launches at the World's Fair, the success of which enterprise is well known.



C. DENSMORE WYMAN.

FORTY THOUSAND children attended the Mid-Winter Fair at the expense of the San Francisco Examiner.

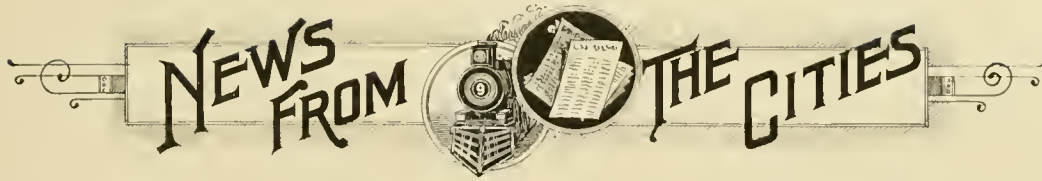

**American Street Railway Association.**

HENRY C. PAYNE, PRESIDENT, Milwaukee, Wis.  
 WM. J. RICHARDSON, SECRETARY AND TREASURER, Brooklyn, N. Y.  
 W. J. STEPHENSON, FIRST VICE-PRESIDENT, Washington, D. C.  
 J. R. CHAPMAN, SECOND VICE-PRESIDENT, Grand Rapids, Mich.  
 LEWIS PERRINE, THIRD VICE-PRESIDENT, Trenton, N. J.  
 EXECUTIVE COMMITTEE: D. F. LONGSTREET, Denver, Col.; T. H. McLEAN, Indianapolis, Ind.; ED. WHITTACRE; W. Y. SOPEL, Ottawa, Ont.; and E. S. GOODRICH, Hartford, Conn.  
 Place of next meeting, Atlanta, Georgia, third Wednesday in October, 1894.

**Massachusetts Street Railway Association.**

President, J. H. CUNNINGHAM, Boston; First Vice-president, AMOS F. BREED, Lynd; Second Vice-president, FRANK S. STEVENS, Fall River; Third Vice-president, SAMUEL WINSLOW, Worcester; Secretary and Treasurer, A. E. BUTLER, Lawrence, Executive Committee, A. A. GLASIER, Boston; E. C. FOSTER, Lynd; CHAS. ODELL Salem; P. F. SULLIVAN, Lowell; E. P. SHAW, Newburyport; PRENTISS CUMMINGS, Boston; R. S. GOFF, Fall River.  
 Regular meetings first Thursday of each month.

**Maine Street Railway Association.**

President, W. R. WOOD, Portland.  
 Secretary and Treasurer, E. A. NEWMAN, Portland.  
 Executive Committee, GEO. E. MACOMBER, Augusta; WM. R. WOOD, Portland, AMOS F. GERALD, Waterville; CHAS. H. PRESCOTT, Biddeford and FRANK W. DANA, Lewiston.  
 Next meeting at call of executive committee, August, 1895.

**Ohio State Tramway Association.**

President A. E. LANG, Toledo; Vice-president, W. J. KELLY, Columbus; Secretary and Treasurer, J. B. HANNA, Cleveland; Chairman Executive Committee, W. A. LYNCH, Canton, O.  
 Meets at Toledo on the fourth Wednesday in September, 1894.

**The Street Railway Association of the State of New Jersey.**

President, JOHN H. BONN, Hoboken; Vice-president, THOS. C. BARR, Newark, Secretary and Treasurer, CHARLES Y. BAMFORD, Trenton; Executive Committee, OFFICERS and C. B. THURSTON, Jersey City; H. ROMAINE, Paterson; LEWIS PERRINE, JR., Trenton.

**The Street Railway Association of the State of New York.**

D. B. HASBROUCK, PRESIDENT, New York City.  
 G. TRACY ROGERS, FIRST VICE-PRESIDENT, Binghamton.  
 JAS. H. MOFFATT, SECOND VICE-PRESIDENT, Syracuse.  
 WILLIAM J. RICHARDSON, SECRETARY AND TREASURER, Brooklyn.  
 The next meeting will be held at Syracuse, on the third Tuesday in September 1894.

**Pennsylvania Street Railway Association.**

H. R. RHOADS, PRESIDENT, Williamsport.  
 G. L. JONES, FIRST VICE-PRESIDENT, Reading.  
 S. P. LIGHT, SECRETARY, Lebanon.  
 WM. H. LANIOUS, TREASURER, York.  
 Next meeting at Reading first Wednesday, in September, 1894.

**Texas Street Railway Association.**

WM. H. SINCLAIR, PRESIDENT, Galveston.  
 S. A. HOBSON, SECRETARY AND TREASURER, Waco.  
 J. K. URIE, VICE-PRESIDENT, Austin.  
 Next meeting, third Wednesday in January, 1895.

**Alabama.**

TUSKALOOSA, ALA.—S. C. Weatherford has leased the Castle Hall Company's Street Railway line and will begin operation.

**Arkansas.**

PARAGOULD, ARK.—T. B. Ketchum is made receiver of the Electric Light & Power Company.

LITTLE ROCK, ARK.—In the case of Charles A. Coffin and the Thomson-Houston Electric Company vs. Horace G. Allis and wife, a decree of \$283,200 was found for plaintiffs.

LITTLE ROCK, ARK.—In the case of the Atlantic Trust Company vs. the City Electric Railway, it has been determined that the present receivers, S. W. Fordyce and Allen Johnson, act as receivers in this cause also without additional bond.

**California.**

LOS ANGELES, CAL.—W. H. Workman has begun work on his electric railway. It must operate within the year.

SAN FRANCISCO, CAL.—Sheriff attaches three cars of the San Francisco & San Mateo to satisfy claim of \$771.00 held by John A. Roebling Sons' Company.

SACRAMENTO, CAL.—Albert Gallatin is elected president and Joshua Barker secretary of the electric railway. G. P. Kingsbury has entered on his duties as superintendent.

SACRAMENTO, CAL.—Albert Gallatin and Horatio Livermore, of San Francisco, have bought the Sacramento electric system. A. Saulsbury, late of Minneapolis, is made superintendent.

SAN FRANCISCO, CAL.—Stockholders of The Consolidated order issue of \$17,500,000 in bonds, 49-years-life, at 5 per cent. A stockholder says \$500,000 to \$1,000,000 will be put into electrical equipment within six months.

OAKLAND, CAL.—Bondholders and stockholders of the Piedmont Consolidated want the line equipped with electricity. It is estimated that \$16,000 will be required for the change, in addition to the sum already granted.

SACRAMENTO, CAL.—Gallatin & Livermore have bought Oak Park, a 16-acre tract, and will make a pleasure resort of it. The entire street railway system will be renovated. New rail will be laid, new trucks will be bought, and old cars reconstructed.

SAN FRANCISCO, CAL.—Superintendent Johnson Reynolds, of the Sutter street line, is deeply interested in the Hough storage battery car, which is being built by the Main Street Iron Works. A motor of special winding is being constructed. Arthur Hough is president of the company.

**Canada**

WINDSOR, ONT.—Col. J. M. Clark has recovered from his illness and will begin work on his Amherstburg line.

GAULT, ONT.—The Gault & Preston Street Railway Company will shortly be in a position to award contracts for the construction of their road.

HAMILTON, ONT.—Hamilton Radial Street Railway Company will amend its ordinance to increase capital stock, build new line to Niagara Falls and other places, and enlarge its corporate powers.

MONTREAL, QUE.—The parish of St. Martin will build an electric railway on the Isle Jesus, near Montreal, to connect that island with this city. Hon. R. Thibaudeau, G. W. Parent and R. S. Williams are interested in the scheme, which is contemplated as an extension of the Park and Island Electric Railway.

**Chicago.**

CHICAGO.—Alley L officials say that the Englewood extension of the L will not be built. The company will build to the Stockyards instead.

CHICAGO.—F. O. Rusling of the Calumet Electric Railway, Chicago, goes to Buffalo to become superintendent of the City Railway Company.

CHICAGO—Organized, the Crown Belting Company, at \$50,000, by Frederick F. Warner, Russell B. Smith and Samuel S. Page, to manufacture and sell belts.

CHICAGO.—The city council grants a franchise to the North Chicago Street Railway Company to operate an electric line on Lincoln avenue between Wrightwood avenue and North Fifty-ninth street. The ordinance is for twenty years, and a five cent fare is specified.

The North Side Electric Street Railway Company has introduced its ordinance. It takes in numerous north and northwest side streets. Alderman John Sexton introduced the measure.

### Colorado.

DENVER, COL.—Geo. E. Randolph and C. S. Sweetland, receivers of the Denver City Cable Railway, file report for December: receipts, cable, \$25,537; total receipts, \$27,808; expenses, \$22,138.

DENVER, COL.—J. H. Crandall, 1637 Blake street, is in the market for 200 gross tons 50-pound steel T-rail; 375 tons 40-pound steel T-rail, and a second-hand standard gauge low-wheel 50-ton freight locomotive.

DENVER, COL.—The Eldorado Land Development Company is incorporated with a capital of \$1,000,000, by J. W. Shannon, G. A. Smith and J. M. Jones. They will build and operate electric light and railway plants in Taos, Rio Arriba, Colfax, Santa Fe and Mora counties, New Mexico. Principal offices at Denver.

### Connecticut.

MERIDEN, CONN.—The Middletown-Meriden road will be built by July 1. The company is in the hands of a syndicate represented by ex-Governor Thomas M. Waller and Attorney S. H. Wagner, of New Haven. A large power house will have to be built in Middletown.

NEW HAVEN, CONN.—The Winchester Avenue and New Haven & West Haven Street Railway Companies extensions were decided upon. The stockholders of both roads elected the following officers: Albert C. Pond, of Boston, president; Israel A. Kelsey, secretary, treasurer and manager; Albert E. Pond, superintendent; E. W. Decker, superintendent of the Winchester lines.

### Delaware.

WILMINGTON, DEL.—George E. Pratt, formerly sales agent of the Lamokin Car Company, has resigned, to take a similar position with Jackson & Sharp, of this city, in the street railway department.

### District of Columbia.

WASHINGTON, D. C.—A bill to amend route of the Rosslyn, Arlington & Mount Vernon Street Railway Company is introduced. Geo. W. Moore, Clarence Baker et al are incorporators and original incorporation was made in 1890.

WASHINGTON, D. C.—Officers elected of the Washington, Alexandria and Mt. Vernon Electric Railway Company: Griffith E. Abbott, president; F. A. Reed, vice president; Frank K. Hipple, secretary; Gordon G. Noble, assistant secretary; David C. Leech, treasurer; Daniel W. Holden, assistant treasurer.

### Georgia.

ATHENS, GA.—Robert Vandyke has sold the Athens Street Railway to Birmingham parties who will remove it to the latter place.

ATLANTA, GA.—The Atlanta Consolidated effects its reorganization. President Joel Hurt succeeds in gaining the consent of stockholders. Money is forthcoming to pay the company's debts and interest is reduced to 3 per cent for two years; after that it is to be 5 per cent.

### Illinois.

OTTAWA, ILL.—The Street Railway Company wishes to abandon certain non-paying lines temporarily.

HARVEY, ILL.—The A. Thompson Belting Co. has placed its machinery in operation and promises to become a thriving concern.

ABINGDON, ILL.—The Abingdon Electric Light Company, incorporated at \$12,500 by C. C. Travis, Annie J. Travis and C. D. Warner.

AURORA, ILL.—Manager Belden, of the street railway, has decided to put in a separate generator for power users, in accordance with insurance rules.

PEORIA, ILL.—Officers of the Fort Clark Electric are: President, F. W. Horn, Chicago; secretary and treasurer, J. W. Trawick; company physician and surgeon, Dr. C. E. Davis.

WAUKEGAN, ILL.—Incorporated, the Waukegan Electric Railway Company, Waukegan; capital stock, \$500,000; incorporators, M. C. Vanfleet, Ben L. Jones and W. C. Palmer.

FREEPORT, ILL.—C. E. Loss, of Chicago, has closed a contract for the new electric railway at Freeport, Ill. It will comprise six miles of single track with turnouts, five cars and equipments, two 90 K. W. generators, 220-horse-power in engines.

ROCKFORD, ILL.—Jason C. Ayres of Dixon, F. G. Jones, Oregon, and James S. Ticknor, George E. King, Harry B. Andrews of Rockford, have organized the Rockford & Dixon Electric Railway Company to connect the towns mentioned by sixty miles of electric railway. The incorporation will be called the Rock River Electric Railway Company, and, it is said, the men behind it are all capitalists. Mr. Ticknor is the manager of the Rockford railway.

### Indiana.

MARION, IND.—Marion Street Railway has decided to extend to Fairmount, six miles beyond present limit.

ELKHART, IND.—The Electric Light & Railway plant has been bid in by O. N. Lumbert, its old president, for \$21,000, at receiver's sale. He is supposed to be backed by outside money. The incumbrance is \$75,000.

MARION, IND.—The old Marion Street Railway Company transfers all its rights and property to the Marion City Railway Company, of which W. H. Carroll is president; Jas. V. Sweetser, secretary. Bonds will be issued to the amount of \$400,000, and the money used to build to Jonesboro, Gas City and Matter Park.

INDIANAPOLIS, IND.—The Farmers & Broad Ripple Street Railway Company organized to construct and operate street railways in Marion and Hamilton Counties. Capital stock fixed at \$100,000 and the incorporators are Secretary of State W. R. Myers, Judge John C. Green, A. N. Fisher, Henry Malpas and O. C. Myers.

### Iowa.

SIoux CITY, IA.—C. D. Smiley, of the South Sioux City, Neb., Street Railway Company, is pressing forward the building of his line.

SIoux CITY, IA.—Decree of foreclosure granted to bondholders of the Sioux City Street Railway Company will assist in reorganization.

SIoux CITY, IOWA.—Sioux City & Morningside Street Railway, incorporated by H. A. Jandt, Judge Larimer et al., is to get its franchise.

DES MOINES, IA.—A bill is introduced in the legislature here, the object of which is to compel the vestibuling of street cars in the State of Iowa.

BURLINGTON, IA.—The Blake-Ray application for franchise for a street railway line is under consideration of the council. They propose a gas motor of some description.

SIoux CITY, IA.—Court grants judgment in favor of the Fidelity Loan & Trust Company, against the Sioux City Street Railway Company, for \$558,000 on its bond issue. Trust deed will be foreclosed.

SIoux CITY, IA.—South Sioux City Street Railway Company elects officers: Frank Hunt, president; C. D. Smiley, secretary; J. P. Twohig, treasurer. It was decided to extend the line to the South Sioux City depot in the near future.

### Kansas.

FT. LEAVENWORTH, KAN.—It is reported that Capt. C. F. Roe, U. S. A., and Louis F. Goodsell and G. F. Anthony, Newburg lawyers, have a plan under way for an electric line from Highland Falls to West Point.

LEAVENWORTH, KAN.—The franchise for electric railway has passed council and been accepted by Newman Erb, the builder. He is authorized to issue scrip and electrify ten miles of track.

PITTSBURG, KAN.—Forest Part Electric Street Railway, in toto, is sold by Receiver, Sam Barratt to L. Bidell, of the Neosho Valley Investment Company. The new owners will immediately extend four miles, to Frontenac.

## Kentucky.

LOUISVILLE, KY.—The Louisville Railway Company elects officers as follows: J. B. Speed, Buffalo, president; St. John Boyle, vice-president; T. J. Minary, general manager; R. A. Watts, secretary and treasurer; J. M. Pettus, assistant secretary and treasurer.

## Maine.

LEWISTON, ME.—It is announced that the Lewiston & Auburn Horse Railway has been purchased by E. E. Proctor, of Wakefield, Mass. E. W. Gross has been made treasurer and general manager. Electricity will be installed.

## Maryland.

CENTERVILLE, MD.—I. B. Brown, W. W. Busted and Wm. Emory, of Centerville and R. C. Davidson, Bartlett S. Johnston, W. B. Brooks, Jr., and W. S. Bosley, of Baltimore, have organized the Centerville Electric Railway Company. The capital is fixed at \$500,000.

CENTERVILLE, MD.—A Queen Anne County electric railway is organized by I. B. Brown, W. W. Busted and Wilmer Emory of Centerville, and R. C. Davidson, Bartlett S. Johnston, W. B. Brooks, Jr., and William S. Bosley of Baltimore. Proposed capital, \$500,000. The plan has not been fully formed.

FREDERICK, MD.—Incorporated: the Frederick & Middletown Electric Railway Company by Peter H. Bussard, D. Edward Kefauver, Peter W. Shafer, Charles H. Coblenz and Herman L. Routzahn of Middletown, and George William Smith, Dr. U. A. Sharretts, Thomas H. Haller and Charles V. S. Levy of Frederick.

BALTIMORE, MD.—The Baltimore Traction Company has asked the city council to allow it to lay tracks in different parts of the city, and to extend one of its lines to Westport, a growing town on the south bank of a branch of the Patapsco river.

The Central Electric Railway Company has also asked to be allowed to lay tracks from the company's present tracks, at Preston and Brevard streets, along a number of streets of North and East Baltimore.

Up to date the rumor regarding the Consolidation of all street railways in Baltimore has not been verified; if such a thing has occurred, it has not been made public.

## Massachusetts.

AUBURN, MASS.—Auburn Electric Motor Company elects John C. Blake, clerk; W. A. Robinson, treasurer.

FALL RIVER, MASS.—The Dartmouth & West Port Electric Railway elects: President, Frank W. Brightman, Fall River; vice-president, Abbott P. Smith, New Bedford; treasurer, J. A. Beauvais, New Bedford; clerk, Robert S. Goff, Fall River. The line from Smith Mills in Dartmouth and the Narrows in Fall River will be in operation in July.

## Michigan.

BATTLE CREEK, MICH.—City Treasurer Corwin has levied on the engines and boilers of the electric to pay city taxes.

DETROIT, MICH.—Albert Kern, 171 Griswold street, Detroit, wants addresses of dealers in second-hand electric supplies.

ANN ARBOR, MICH.—J. E. Beal, H. P. Glover, et al., of Ypsilanti Street Railway Company, and C. E. Hiscock, H. T. Martin, et al., of the Ann Arbor road, are trying to consolidate.

SHEBOYGAN, MICH.—End, Schneider and Dean have sold their right for the street railway to F. Saeman, president, and H. E. Thomas, secretary and treasurer, of a new company. The line will run to Sheboygan Falls.

ST. JOSEPH, MICH.—Contract for grading the St. Joseph & Lake Shore Electric road has been let to A. B. Wilgus, of New York City.

YPSILANTI, MICH.—A plan is brooched to consolidate the Ann Arbor Electric Railway and the "Ypsi-Ann" Railway. This means equipping the latter electrically and building a new power-house. Meeting has been held.

## Minnesota.

NORTHVILLE, MINN.—A line between Northville and Mallette is being seriously considered.

MINNEAPOLIS, MINN.—T. B. Walker, who owns the St. Louis Park Electric Railway says that his line will be extended two miles to Hopkins, this summer.

MINNEAPOLIS, MINN.—The wages of the Twin Cities' employes have been cut. The city men are reduced from 17 to 16 cents an hour and the interurban from 20 to 17.

STILLWATER, MINN.—In the case of Allan Curtiss against the Stillwater Street Railway Company, judgment for the plaintiff was given in the sum of \$67,709. The next step will be the foreclosure and sale of the property at sheriff's sale.

## Mississippi.

MERIDAN, MISS.—The Thomson-Houston electric light plant burned February 4. Loss, \$50,000; insurance, \$40,000.

GREENVILLE, MISS.—Greenville Street Railway tracks torn up by order of the council for failure to comply with ordinance. Damage, \$3,000.

## Missouri.

SPRINGFIELD, MO.—The city gives its consent to the transfer of the Metropolitan Railway Company.

ST. LOUIS, MO.—President Chas. H. Turner, of the St. Louis & Suburban Electric Railway, contemplates buying the Clayton & Forest Park Railway, to operate with the Suburban.

ST. LOUIS, MO.—It is stated that the Missouri Railroad Company will change motive power from cable to electricity. Poles have been placed along part of the route and extensions are said to be contemplated.

JOPLIN, MO.—It is reported that the Southwestern Electric Light Company is to buy the Joplin Street Railway line and considerably extend it. The money comes from the Missouri, Kansas & Texas Trust Company.

ST. LOUIS, MO.—The city council will take steps to compel erection of an iron bridge by the Merchants' Bridge Terminal Company.

It is rumored that the Fourth Street & Arsenal Street Railway will be changed to electricity by President Chas. Green.

ST. JOSEPH, MO.—John R. Owens, receiver of the People's line, files final report. Cash received from operation of the property from June 1, 1893, to July 5, 1893, \$23,551.14; received from master in chancery, \$5,199.72; total receipts, \$33,314.74. Expenditures, indebtedness paid by receiver, \$5,199.72; total expense for operating the lines from June 1, 1893, to July 5, 1893, \$20,687.40; August pay rolls, \$8,474.57; interest paid Harriman & Co. to February 1, 1893, \$456.17; total expenditures, \$35,252.07; receivers indebtedness, \$1,937.33; bills uncollected, \$1,578.75.

## New Hampshire.

NASHUA, N. H.—John A. Fisher is elected president of the street railway, vice George H. Knowles, resigned. This is said to mean radical changes, extensions, and perhaps an interurban to Haverill, as Boston capitalists are thought to have gained control of the system.

## New Jersey.

SOMERVILLE, N. J.—The Bound Brook works of the Standard Paint Company burn. Loss, \$200,000.

ELIZABETH, N. J.—Suburban Railway and Electric Company incorporated at \$750,000 by W. B. Hosmer, of Boston, 500 shares; James B. McGiffert, of Roselle, 500 shares; Charles H. Newhall and John S. Bartlett, of Lynn, Mass., each 1,000 shares.

## New York.

LOCKPORT, N. Y.—Willard T. Ransom says that the Lockport-Olcott electric railway scheme will go through.

WILLIAMSVILLE, N. Y.—F. C. Fisk has resigned superintendency of the Buffalo & Williamsville Electric Railway.

NEW YORK CITY.—It is said that Russell Sage will build another story to the Manhattan "L" for express service.

BUFFALO, N. Y.—The Street Railway Company is about to contract for 2,500-horse-power from the Niagara Cataract Construction Company.

NEW YORK CITY.—Newburg Street Railway property has been sold to President Norton, of the Atlantic Avenue Railroad Company, Brooklyn. Electricity will be used.

NEW YORK CITY.—State Railroad Commission is asked for rights by the Metropolitan Railway Company, to change its motive power to cable: another section of its line. No opposition.

BROCKTON, N. Y.—The Brockton, Chautauqua County, Street Railway Company has been incorporated at \$10,000 capital stock, by Owen W. Powell, T. C. Moss and C. F. Ryckman, of Brockton, and others.

NEW YORK CITY.—A big interurban electric railway scheme is on foot for the uniting of a number of New Jersey towns. John D. Crammins is at the head, and the plan is to make the most extensive system ever contemplated.

NEWBURGH, N. Y.—Newburgh Street Railway sold at auction under execution issued to the Farmers' Loan & Trust Company. Benjamin Norton, of the Atlantic Avenue road, Brooklyn, bought it for \$30,000. Electricity will be substituted, and line greatly extended.

SYRACUSE, N. Y.—The owners of the Syracuse Street Railway Company, W. W. Hazzard, of Cincinnati, O., Geo. E. Herrick, et al., of Cleveland, decide on the erection of a new and extensive power house. The other large improvements will be made this spring. The power house will cost \$160,000.

JOHNSTOWN, N. Y.—The Johnstown, Gloversville & Kingsboro Horse Railway Company has elected the following directors: H. S. Judson, John H. Stockamore, J. H. Place, James Younglove, William D. Ferres, George C. Burr, John M. Russell, Jacob Hees, James Shanahan, Jr., William P. Myers, A. Z. Wemple, Harwood Dudley, J. M. Carroll.

NIAGARA FALLS, N. Y.—Niagara Falls, Whirlpool & Northern Railway is incorporated, by Jacob B. Vogt, Niagara Falls; Elisha M. Fullin, Jr., Rye, N. Y.; J. M. Lewis, of Elizabeth, N. J.; H. Watkins, of Orange, N. J.; W. J. Duane, of New York; Eliot Norton, of New York; Burt Van Horn, Jr., of Niagara Falls; John C. Lammerts, of Niagara Falls; William H. Hodge, of Niagara Falls. Electricity is to be used.

NEW YORK CITY.—On application of A. A. Whitman, treasurer, and Percival Knauth, president, the Waddell-Entz Company of 203 Broadway has been placed in the hands of Montgomery Waddell as receiver. Knauth and Whitman hold debenture notes for \$13,000 each. Besides this Mr. Knauth is creditor for \$13,000 and the company owes \$30,000 in addition. Assets are plant at Bridgeport, patents and \$2,000 in New York.

## Ohio.

CINCINNATI, O.—John Kilgour, it is said, will build a belt line taking in Madisonville.

CLEVELAND, O.—Buckeye Electric Company increases capital stock from \$250,000 to \$300,000.

ZANESVILLE, O.—Zanesville Street Railway Company increases capital from \$200,000 to \$300,000.

CINCINNATI, O.—Cincinnati Street Railway Company will build a new power house at Cummingsville.

AKRON, O.—E. L. Babcock, of Cuyahoga Falls, et al, ask rights for the Akron-Cuyahoga Electric Railway line.

CLEVELAND, O.—Cleveland Electric Railway Company will build long extension to Brooklyn village in the spring.

WOOSTER, O.—The city council has extended the time of the franchise given to B. M. Barr, of Cleveland, for an electric line here.

OSHERLIN, O.—John F. Randolph, Judge Steel, H. C. Wengerien et al, of this place, are looking over the route for a line from Oberlin to Lorain.

TOLEDO, O.—J. A. Dawson says that the Toledo Monroe & Detroit Electric Railway Company is ready for incorporation. Surveyors will soon lay out the route.

JEFFERSON, O.—The plan of an electric railway to Geneva, via Austinburg, is fathered by Hon. Edward N. Fitch, who will look after the plans and incorporation.

NEW PHILADELPHIA, O.—Major C. E. Michener, president of the Tuscarawas Rapid Transit, says that a line will connect this place with Uhrichsville during the summer.

TOLEDO, O.—Toledo, Maumee & Perrysburg Electric Railway is incorporated, by J. K. Tillotson, Frank Ohl, Dustin Atwood, et al Express and freight service is expected.

WARREN, O.—A company is incorporated at \$10,000, to build an electric between Kinsman and Farmdale, in this county, by D. M. Yemmans, E. R. Brackin, J. W. Forbes, and J. A. Russell.

CINCINNATI, O.—Cincinnati, Newport & Covington elects: John J. Shepherd, of Cleveland, president; Chas. E. Orr, of Pittsburg, vice-president; H. P. Eells, Cleveland, treasurer, and J. H. Hoyt, Cleveland, secretary.

FRONTON, O.—R. T. Greaves, engineer, of Lynchburg, Va., and J. V. Vandergrift, of Philadelphia, are here making estimates on an electric line. Will build a power house. Superintendent T. T. Johnson, of the I. & P. Street Railway Company, has particulars.

LANCASTER, O.—Lancaster Street Railway elects: Wm. Duffy, president; C. F. Nestor, secretary; A. Bauman, secretary and manager. Extension contemplated to the Boys' Industrial Home, six miles. Assessment order to be paid March 10, which will clear all indebtedness.

DAYTON, O.—The City Railway Company has taken steps towards the electrifying of its lines before July 1. Brownell & Co., of Dayton, will furnish the boilers, Buckeye Corliss engines will be used, and Siemens-Halske direct driven generators. Power house to be built very soon.

CLEVELAND, O.—John Walker, for whom the Walker Manufacturing Company was named, and one of its founders, and holding the office of vice-president and general manager, has resigned and withdraws from the company, so far as active management is concerned. Frank Billings was elected vice-president and W. H. Bone, general manager.

## Pennsylvania.

PHILADELPHIA, PA.—P. A. B. Widener says he will adopt some form of alarm gong on the trolley cars.

POTTSVILLE, PA.—Wm. H. Conrad, of Reading, is made superintendent of the Schuylkill Electric road here.

POTTSVILLE, PA.—William H. Conrad, of Reading, has been made superintendent of the Schuylkill Electric Railway.

PITTSBURG, PA.—The Westinghouse Electric & Manufacturing Company will build a big machine shop at Brinton, to make electric machinery.

LOCKHAVEN, PA.—Edward Carr, representing several construction companies in New York, is here concerning the advisability of building a street railway line.

PHILADELPHIA, PA.—Mayor Stuart has signed the ordinance authorizing the construction of the elevated electric. The Seligmans, of New York, are interested.

WEST PITTTSTON, PA.—West Pittston capital has purchased Everharts Island, and it is proposed to run the Wyoming Valley Traction Company to the place for a pleasure resort.

PHILADELPHIA, PA.—Mr. Hetzell has introduced bill into select council on behalf of Theodore Cramp, president of the Market Street, Richmond & Frankfort Elevated Railway. The line is to be eight miles long, operated by electricity, and built of iron.

LANCASTER, PA.—The Lancaster Traction Company elects the following directors: Ex-Senator John J. Patterson, J. Hay Brown, Esq., Mr. John D. Skiles, Mr. B. J. McGrann, Mr. John Hertzler, Mr. Michael Reilly, Mr. John S. Graybill, Col. James Young, Mr. Carl F. Espenshade, J. W. B. Bausman, Esq., and Dr. M. L. Herr.

PHILADELPHIA—Charter is granted the East Snyder Avenue Passenger Railway Company. Capital, \$60,000; incorporators, Henry C. Moore, David C. Golden, Hyland C. Murphy, McClellan Hersh, Joseph C. Dugan and Thomas B. Foot. The Cherry Street Passenger Railway Company, of Philadelphia, two miles in length, same incorporators as above; capital stock, \$12,000.

PHILADELPHIA.—The Robinson Machine Company asks its creditors to agree to an extension on all accounts due, and offers six and twelve months notes in settlement. Assets are placed at \$36,602; liabilities \$18,635.

## South Carolina.

CHARLESTON, S. C.—It is reported that the deal has been closed between street railway people here and New York parties, and that the property will be transferred to them shortly. Price, \$180,000, and the system will be changed to electricity in the very near future.

## Tennessee.

NASHVILLE, TENN.—Nashville Electric Railway assigns to Robert F. Jackson. The debts of the company amount to \$9,000. The creditors are the J. G. Brill Co., General Electric Company and the Continental Trust Company. The property will be sold.

MEMPHIS, TENN.—The East End Dummy Line and the Citizens Street Railway will be united and have gained legislative consent to the action. Col. John Ovington, Jr., represented the Dummy line, and Manager Frank Jones represented the Citizens. The Dummy line will be immediately electrified.

NASHVILLE, TENN.—The report of receivers J. H. Thompson and T. W. Wrenne shows: "The receipts, including \$711.52 turned over to the receivers by the old management, amount to \$16,610.28; the expenditures were \$10,737.82. The expenses for the same period last year were \$1,843.83 more than during the same month this year."

NASHVILLE, TENN.—Superintendent E. G. Connette has appointed J. A. Martin in charge of the North and Western lines and John Corlew in Martin's place as division superintendent of the East Nashville division. These changes are occasioned by the death of John Haley, former division superintendent of North and West lines.

## Texas.

TEXARKANA, TEX.—A project is on foot to build a dummy line from this city to the Normal school.

WACO, TEX.—W. W. Seley is made receiver of the Waco Electric Light & Railway plant. Plant is valued at \$250,000.

WACO, TEX.—Waco Electric Railway & Light Company goes into the hands of a receiver. Assets, \$300,000; liabilities, \$200,000.

FORT WORTH, TEX.—The North Side Street Railway, which has been operated by a receiver since January 1, 1892, will be advertised and sold to the highest bidder April 1.

BEAUMONT, TEX.—The directors of the Beaumont Street Railway decided to sell the plant to any one who will assume the \$2,000 indebtedness and pay stockholders 5 per cent on the paid up stock of \$8,600.

DENISON, TEX.—Denison Street & Belt Line Railway Company is organized. Officers elected: President, A. P. Childs, of Bennington, Vt.; vice-president, E. H. Hanna, of Denison; and treasurer, A. H. Coffin, of Denison; secretary, A. Zintgraff, of Denison.

## Utah.

SALT LAKE CITY, UTAH.—Joseph W. Summerhays is principal promotor of the Glen Park electric line, which, he says, will be built in 1894, and will be fourteen miles long.

## Vermont.

WATERBURY, VT.—Mount Mansfield Electric Railway is incorporated to build between Waterbury and Stowe, ten miles. Water power is to be used. E. D. Blackwell, Montpelier, is president; O. E. Luce of Stow, vice-president; L. A. Pike of Stowe, clerk, and L. C. Moody of Stowe, treasurer. C. N. Arms and G. W. Randall of Waterbury are also interested.

## Virginia.

PETERSBURG, VA.—Receiver Robert Gillam appoints Geo. Beadle superintendent of the Petersburg and the Petersburg Asylum roads. Some improvements are to be made.

RICHMOND, VA.—Fairmount Railway Company wants to build a line in Henrico county. Incorporators, Fred C. Brauer, Jr., John H. Dinneen, Samuel H. Pulliam, V. Hechler, Jr., and William T. Hechler, Jr. The capital stock is to be not less than \$10,000 nor more than \$500,000.

RICHMOND, VA.—The Southern Railway & Electric Company seeks incorporation. Thomas N. Kendler, G. D. Patch, Andrew Pizzini, Jr., and others are the incorporators. The proposed road is between Richmond and some point on the Potomac between Great Falls and Alexandria.

## Washington.

SEATTLE, WASH.—A. F. Burleigh, A. F. Haas, T. A. Gamble and J. L. Dudley are elected trustees of the Seattle City Railway Company. Mr. Burleigh is temporary chairman.

## Wisconsin.

MILWAUKEE, WIS.—Manager Payne says that by July 1 cars will run to Greenfield from the city.

ASHLAND, WIS.—Street Railway Company asks council to allow suspension of operations until spring. No traffic and bad streets alleged cause.

GREEN BAY, WIS.—The Green Bay Electric Railway Company is to apply for a franchise in Du Pere. This is a plan for an extensive inter-urban.

LA CROSSE, WIS.—The project to equip the Onalaska Street Railway with power is revived, and capital increased by \$20,000. Power will be taken from the La Crosse Railway plant.

OSHKOSH, WIS.—C. O. Mailloux of New York City; Wm. Jarvis, of Louisville, Ky., and J. K. Tillotson, of Toledo, O., are independent inquirers for the franchise to be given here to some one.

MILWAUKEE, WIS.—Milwaukee and Wauwautosa Rapid Transit Company elects: President, Charles Stickney; vice-president, Julius Wechsely; secretary and treasurer, C. W. Henning; counsel, E. S. Elliott; superintendent, E. D. Hoyt.

LA CROSSE, WIS.—The La Crosse-Onalaska Street Railway Company elects officers and decides on electrical equipment. Officers are: President, J. B. Canterbury; vice-president, S. Y. Hyde; secretary and treasurer, E. B. Magill. Hon. Frank Pooler of Onalaska and John Walker of North La Crosse were elected directors.

## Playing Cards.

You can obtain a pack of best quality playing cards by sending fifteen cents in postage to P. S. Eustis, Gen'l Pass. Agent, C. B. & Q. R. R., Chicago, Ill.

## E. C. FOSTER.

From the Milk Wagon to the Manager's Desk.—The Story of a Self Made Man.—Manager of the Lynn & Boston.

How E. C. Foster, by dint of pure self-effort, rose from the lowly position of a milk wagon driver to the managership of one of the finest electric railway constructions in the world, is the story of the life of the man whose portrait adorns this page.



E. C. FOSTER.

Mr. Foster was born in Hancock, N. H., of a stern New England ancestry. At the age of sixteen, after a year at Appleton Academy, Ipswich, N. H., young Foster left the parental roof to go it alone in the world. He headed for Boston and stopped at Lynn, where he has been ever since. Arriving at Lynn he took the first position he found, which was on

a milk wagon. With a Yankee boy's grit he stuck to the distribution of the lacteal fluid for three years, when he took to the platform of a street car. He collected fares for several years, became car starter, and finally went to California to better himself. The east had its attractions, so he returned to the rear platform at Lynn. He soon afterwards became superintendent of track construction. Just before he was thirty he attracted the attention of A. F. Breed and Stephen Green, two well-known capitalists. Through their influence and by their aid he found himself superintendent. His executive ability there found opportunity, and in 1892 he became general manager of the Essex County system.

Mr. Foster is a tall, muscular man, with keen eyes and black hair, interested in everything, capable of unlimited effort, and one of the best disciplinarians. Some of the men who have been graduated under him occupy high street railway positions; among them, W. W. Sargent, superintendent of the Fitchburg system; W. Wentworth, superintendent of the Haverhill, Merrimac & Amesbury; Frank Hunnewell, who went to Gloucester; J. E. Sewall, who went to Woburn, but returned to manage the Chelsea division of the Lynn & Boston; H. C. Page, who went to take charge at Newburyport, but was hired back to the road, these, and some others, make a list almost unprecedented for a man only forty years old to send out from under his tutelage to such important positions.

THE Lunkenheimer Company, Cincinnati, has issued a compact little folder, containing up-to-date information on the Lunken gate valve and two pages of illustrations, showing the difference between old and new style valves. A price list fills the last page.

## A SNOW PLOW FOR ROUGH STREETS.

By W. C. Fuchs, Electrician of the Cicero Proviso Electric Railway.

In designing snow plows for removing snow, ice and frozen slush from the track, it is a matter of concern to study the condition of the road bed. There are rails above and below the paving line, also cross overs, switches and loosened blocks protruding above the rest of the paving 3 or 4 inches, and frozen rigid. These are the conditions of a road a plow must run over, to clean the track sufficiently for cars to run without hindrance or delay in running time. To prevent damage to a plow running over such a track is accomplished by having the plow suspended by chains, so that if the plow strikes any rigid obstruction, the plow being suspended by chains, gives it the necessary flexibility, so as to allow the plow to accommodate itself to the irregularities met with.

When plowing over an ordinary smooth road with an uniform or almost uniform load of snow in front of the plow, if it should strike an obstruction having a greater



A SNOW PLOW FOR ROUGH STREETS.

resistance than that offered by the snow it is removing, the plow will place itself in a position bringing up the point struck to glide over the obstruction. Having a severe winter to try this plow, we had no difficulty in running over the road at a good speed in the severest snow storms, without interfering with the work of the plow, or delaying the running of cars at proper periods. The wheels are provided with  $1\frac{1}{4}$  flanges to prevent the plow being thrown from the track when passing through snow banks.

Two 15-horse-power motors are attached to each axle, for driving the plow, and power is transmitted to axles by gear wheels. This imparts a positive motion to the rigid portion of the plow, which is reduced to the desired flexible swinging motion by the chains on which the beams are suspended. To prevent skidding of wheels, sand boxes are used. In rear of plow a pair of "diggers" are provided, which consist of heavy iron bars placed upright in front of the wheels, connected by a wooden cross beam



and fastened to body of plow by springs, which impart flexibility to the "diggers" to prevent them being torn from their fastenings by any obstacle coming in the way. These "diggers" are also provided with V shaped stud shoes, to cut from the rail frozen slush or ice, and to clean snow from the rail in places where the rail is lower than the paving blocks. A "wing" is attached to the plow, which can be lowered or raised at will, and throws the snow four feet from the rail. The greatest angle possible is taken advantage of, so as to have an easy plowing of snow to side of road. Owing to the scarcity of room between diggers and plow and not having sufficient room in front of the wheels to place the brakes, a locomotive brake had to be used between the wheels. The cab serves for the protection of the motors and also to keep tools, extra chains and parts of plow liable to get out of order, so that quick repairs can be made to any damaged portion and thus minimize delay. In a very heavy fall of snow an extra board is attached to the plow, making it



SNOW PLOWING ON ROUGH STREETS.

wider, to go through deep snow drifts. Electricians know the anxiety felt when salt is used to remove snow. Salt should not be used under any circumstance, as its use causes rapid corrosion of the rail bonds. That a snow sweeper has advantages over a plow is admitted, but owing to their enormous initial cost and great expense of maintenance they are a luxury of which we can dream about in the future. After careful examination of the above it will be seen a snow plow of this description answers all practicable purposes at a much less cost than a sweeper. Summarizing the data and expense of a hard winter, with plenty of snow and ice, and studying the condition of road-bed, we come to these points:

- 1st. Have one plow for each three miles of double track.
- 2nd. Do not let the snow get ahead of you.
- 3rd. Have a watchful level-headed man, who is not afraid to "act," stationed with all snow implements ready; who is versed in all details of how to handle his plow. Also have him well acquainted with the roadbed he is instructed to keep clean, and men in his charge who will act according to his instructions.

## FOREIGN FACTS.

THE Matlock Cable Railway reports a net profit of \$1,522 from March to December, 1893; passengers carried, 255,000.

THE Leeds, England, tramways will be leased and operated by the city. Existing horse lines, it is reported, will be electrified.

ADRIANOPLE, TURKEY, is also discussing the advisability of a street railway between suburban stations, and the city. Plans are being prepared.

COREA, ASIA, is to have a line of tramway between Riougsan and Soul. The city of Soul has 250,000 inhabitants, without any means of transporting freight, except ponies.

THE Liverpool Overhead Railway reports for the half-year to December 31: Passengers carried, 2,475,639. The gross receipts from traffic were \$90,014.22 and the working expenses \$68,660.85.

PLANS for the utilization of windmill power for generating electricity are asked by the Holland government. Schemes of methods should be to F. W. Van Eeden, Haarlam, Holland, before July 1.

BAGDAD'S CALIPH has granted a tramway concession for the narrow crooked streets of that town of the Arabian Nights. The genii of progress will now take Bagdad's future into hand and do their best to rehabilitate departed glory.

LAST year 600,000,000 tramway passengers were carried in Great Britain and Ireland, or something less than twice the number carried by Chicago's roads alone. Thirty-five cities own their own lines, and nobody wants to ride on the slow, safe and wearisome horse cars.

A DIVIDEND of 17 per cent has been paid during the past year by one Copenhagen, Denmark, tramway company, another paid 14 per cent. Both are horse car lines with two horses for double-decked cars and one horse for ordinaries. A steam suburban line had to be discontinued for want of patronage. It seems as though electricity ought to pay among Danish lines.

THE meeting of three English companies in London not long ago was presided over by W. J. Carruthers-Wain, who is the George Washington and Christopher Columbus combined of English electric traction. The companies were the Croyden, the North Staffordshire and the London & Greenwich. The first paid 6 per cent, the second 5½ and the third 4 per cent per annum, which in view of the general depression of tramway interests in England is an excellent showing.

## HIGH VS. LOW SPEED ENGINES FOR RAILWAY WORK.

Mr. Young Replies to Mr. Green's Open Letter in the Review.

EDITOR STREET RAILWAY REVIEW:

I notice a letter on page 68 of your February issue, from Mr. Green, of Altoona, criticising my remark in your December number, where I made the assertion that any engine running over 120 revolutions per minute should not be used for street railway purposes. I did not write that article for the benefit of engine manufacturers, but for presidents and directors of electric roads. But as truth is always despised by him whom it injures, I take for granted, as Mr. Green is a manufacturer of high-speed engines, that I must unintentionally have tramped on his corns. Mr. Green says, that if I am right science has been a failure. Now Mr. Green surely forgets that he lives in the last days of the nineteenth century, and that not only steam engines but everything else is being revolutionized, and that some old ideas that have been considered facts are now branded as ignorant illusions and mistaken theories, founded on dreams, instead of experience and dollars and cents. Mr. Green wished to know what experience I have had with engines, and whose make. To this I wish to say, that through twenty-three years I have had something more or less to do with most makes of engines. First, in Europe, with locomotives and marine as well as stationary, both slow and high speed. In this country I have worked on and had under my charge, Straight-line, Taylor, Armington & Sims, Ball—all of high speed type, Cooper, E. P. Allis, Hamilton and Corliss, of slow speed type. And I think I have studied the economy and regulation of these various engines as closely as circumstances would permit. In the rapid development of electricity as a light and power agent, stations have sprung up in every part of the civilized world, for the purpose of developing electric energy. The greater number of these stations were equipped on the cheap plan and no judgment exercised in regard to expenses for maintenance. High-speed engines being cheaper and occupying less space, became for a while fashionable. But remarkably enough, all new stations going up now, as well as those that can afford to change, install slow-speed and generally condensing engines, either single or compound.

Mr. Green seems to think that there is only one thing required of an electric street railway engine and that is that it must maintain constant speed under all conditions. Upon this all electrical and mechanical engineers agree. But there are other things to consider which are of utmost importance to the investor and operator, viz.: Economy in maintenance, and here we have questions of coal, water, oil, waste, repairs and reliability. Financiers now make inquiries and ascertain facts before they invest their money in engines, as they have learned from other men's experiences that if one power house with 1,000-horse-power uses up 20 tons of coal per day, as against another power-house of same capacity 12 tons, they know they can save 8 tons per day, which means 2,920 tons per year, and say, on an average of \$2.00 per ton, makes \$5,840, a good slice of the profit on one item alone. Then the repair of detail parts may be say \$100 per month in one, as against \$10 in the other. Common sense tells us, that if the financiers know this, they are going to invest their money in the engine that costs the least to maintain and lasts the longest. No engine in the world has to stand the severe strain that electric railway engines have. The fluctuation is often as high as 70 per cent. Now, the best regulated high-speed engines will

come as close as 2 per cent between minimum and maximum, while the slow speed will be 1 per cent. Besides, an engine making say, 250 revolutions per minute, as against another at 100 revolutions, will quicker wear out its detail parts, besides, the governors must be closely watched and often rebushed and new pins made, as against the slow speed. Finally, the greater danger of having the engine run away by governor failing to act. We also learn in this sharp competitive and economic age, that a power-station divided into small units is more expensive in all its details than one in large units; hence, it is economy to build a station with large units, and this is just what every well-informed president is doing to-day and what every practical engineer advises. I make a habit of questioning the engineer in charge of every power station I visit, what engine he likes best and the one he thinks the most economical, how much coal is used per horse-power, cost for same, also cost of repairs. The answer is invariably in favor of the slow-speed as against the high. Some, of course, have had less experience with both kinds than others. We can easily make the following analogy: a high-speed engine is like a new pair of shoes used all day on a rocky and graveled walk; result, quickly worn out; a slow-speed, like a new pair of shoes used on a soft carpet; result, long wear. Mr. Green surely agrees with me when I say that the slow-speed compound condensing engine represents to-day the highest grade of intelligence in obtaining power from heat and water at the lowest cost. I am no agent for either high or slow speed engine firms, but simply telling electric managers and investors what my experience has taught me, and I am duty bound to tell the truth pure and simple, no matter whom it benefits or injures.

Yours truly,

BALTIMORE, MD., March 3.

C. P. YOUNG.

## MAINTENANCE OF ROLLING STOCK.

II.

Continuing our comparison of methods of motor repair and inspection, Superintendent Geo. H. Shaw, of the

MADISON CITY RAILWAY,

reports that they have nine cars, each carrying two W. P.-30 motors. All but one of these are in use every day. The equipment is fifteen months old. The only renewal of parts, aside from trolley wheels and brake shoes, was one set of bearings on one car, and this renewal was necessitated by experimenting with cheap grease. Mr. Shaw says: "My experience has taught me that cleanliness, watchfulness and the best supplies will do much toward reducing repair accounts." The barn force consists of one night man, who does inspecting and oiling, and two day men on repair work. Motors are thoroughly overhauled and cleaned every ten days. This is at the rate of about one a day. All defects are reported to the superintendent personally. Rewinding of armatures and all general work is done in the shop. The repair and inspection pay roll amounts to \$5.25 per day. The most trouble is experienced from the burning of commutators.

NORTH SIDE RAILWAY, FORT WORTH, TEXAS.

Charles Bode, chief engineer, reports twelve double motor cars in daily use. They are 3½ years old. Three day men do all the maintenance work. Cars are

inspected and cleaned every other day. Light forging and all bench and handwork is done in the shop. The pay roll is \$6.50 per day.

### THE GALVESTON CITY RAILROAD

has given the matter of repairs a great deal of attention, and makes a very satisfactory showing. There are thirty-five single motor cars, having Westinghouse 30-horse-power motors, and five single reduction T.-H. 25-horse-power. Twenty-six cars are in regular use in winter and forty in summer. The equipment is a year and eight months old. The repair force consists of one night and six day men, the daily pay roll being \$13. This force is considered the smallest it is possible to have and keep up the equipment.

The cost per car mile of repair parts is  $\frac{2.4}{100}$  cents, and the cost of repair and inspection labor  $\frac{3.1}{100}$  cents, or a total of  $\frac{5.5}{100}$  cents, a very good record even for a new road. All repair work is done in the shop, even to casting brake shoes. A motorman's report blank is used, in which the motorman has to report the condition of each part. This he gives to the night inspector, who reports, in a column adjoining the motorman's, the condition of each part as he (the inspector) leaves it.

### THE PETERSEN CONDUIT.

Among the numerous systems to hover around the \$50,000 prize, is the Petersen conduit, a good idea of which can be obtained from a glance at the engraving. One of the principal points of distinction between the



CONDUIT—CLOSING PARTITION.

Petersen and other open conduit systems is that it has a normally closed compartment for the trolley conductors. The trolley arm passes along under a series of loose iron plates, dovetailed into each other, which fall of their own

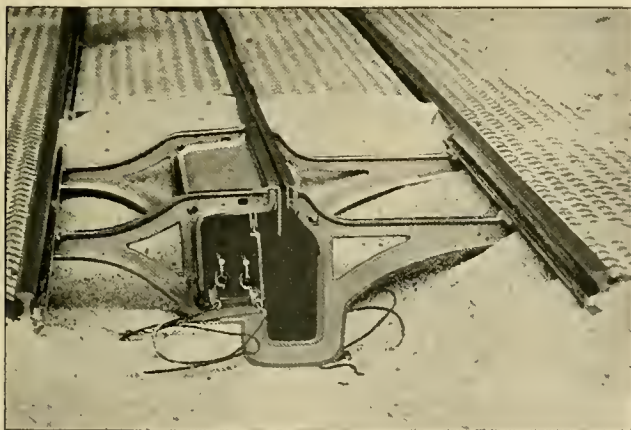

SECTION OF PETERSEN CONDUIT.

weight after the trolley arm is passed, and keep the chamber closed. The conductors themselves are steel rails, and the trolleys are to make sliding contact on top of these. It is intended to keep the trolley compartment

clean and dry by the circulation of air and by carrying a conduit broom on some of the cars. The trolley rails are to be cut up in short sections, with a fuse to each section, so that trouble will be confined to a very short space. H. Peterson, of the Peterson Electrical Works, Milwaukee, is the inventor. It is claimed that a section will soon be built in New York.

The lowest part of the conduit is twenty inches deep, and the bottom of the part containing the trolley is one foot from the top of the slot rails. The feeder cables are laid underneath the trolley conductors as shown in the engraving. It would seem to be a wise move to abandon the use of trolley wire in the conduit as there is generally some trouble with the clamps and its flexibility is often the cause of the trolley coming off.

### W. S. JEWELL.

The new electrical engineer of the Toledo Consolidated Street Railway Company has had a varied and complete education in intramural transit and the science of "getting there."

Mr. Jewell was born at Brentwood, New Hampshire, on the day after the first gun was fired at Fort Sumpter. He did not join the army however on account of the strenuous opposition of his parents. His early education was acquired subsequently at the public schools of Manchester, whither he removed at the age of ten.



W. S. JEWELL.

Later he attended Phillips Exeter academy with the intention of entering Harvard. This course being precluded by ill health, he engaged in various commercial pursuits until 1889, when he entered the employ of the Thomson-Houston Company at Lynn. Once having been thrilled by the electric current Mr. Jewell made its study his life work.

He has been general superintendent of the Des Moines Street Railway Company and the Indianapolis Street Railway Company as electrical and mechanical engineer, both of which positions have been eminently successful connections and we predict continued success for Mr. Jewell in his new field of work, with Mr. Lang past-master of street railway tactics.

An express service is in prospect over the Scullin lines at St. Louis, Mo.

The first car of the Neville Island & Corapolis Street Railway was run March 1.

ELECTRICAL LITERATURE, 565 Rookery, Chicago, a monthly summary of current engineering literature, under the editorship of Professor Stein, of Armour Institute, still continues to increase its scope and usefulness, as the February number testifies.



E. F. SEIXAS has become assistant western manager for the Walker Company, of Cleveland, O.

THE New York Car Wheel Company of Buffalo has established an English agency in London.

THE 250 new cars for the People's Traction Company, Philadelphia, will be equipped with the Davis automatic curtains.

W. J. COOKE, vice-president of the McGuire Manufacturing Company, was a recent visitor at the REVIEW's New York office.

T. S. FRISBEE, representing the P. Wall Manufacturing Company, Allegheny, Pa., is in the city and meeting with good success.

THE removal of the offices of the Clayton Air Compressor Works to the Havemeyer building, New York City, is announced.

MR. COOK, formerly of Madison, Wis., is now at 25 Rialto Building, Chicago, working on a new street railway device that will soon appear in the market.

WILLIAM HAZELTON III, general eastern agent of the Fulton Truck & Foundry Company, New York City, was a recent caller at the Chicago office of the REVIEW.

THE DAVIS CAR SHADE COMPANY, of Portland, Maine, has established an agency in Chicago, with J. M. Denniston as representative. Office, 911 Monadnock building.

A CONTRACT for fifty eight-seat open cars for the Metropolitan Traction Company of New York, has just been closed by the John Stephenson Company of New York City.

THE Canadian General Electric Company has been given a contract by the Toronto, Canada, Street Railway Company for 80 street car motors and about 3,000-horse-power of generators.

THE FULTON TRUCK & FOUNDRY COMPANY has rearranged its officers as follows. W. E. Haycox, president and general manager; M. B. Bushnell, vice-president; C. J. Langdon, Jr., secretary and treasurer.

P. H. CAREY and E. J. Shrader have been appointed agents for the Dick and Church engines, manufactured by the Phoenix Iron Works, Meadville, Pa. The office will be located as heretofore at 519 The Rookery.

THE DODGE MANUFACTURING COMPANY, has made arrangements, through Chicago agent, M. W. Mix, to open a New York branch. A double store room in Dey street has been arranged for that purpose.

JOHN W. BAKER, representing the E. T. Burroughs Company, Portland, Me., is taking advantage of recent good weather to cast his excellent car shade in the west and is meeting with his customary good success.

P. H. CAREY, of 1137 Monadnock Block, Chicago, is distributing the '94 catalog of the W. T. C. Macallen Company, giving illustrations and prices on the extensive line of Macallen sheet mica insulators.

THE BABCOCK & WILCOX COMPANY has removed its main office to 29 Cortlandt street, corner of Church street, New York City. A neat folder, giving views of their various branch offices, bears the tidings.

JOHN DICK, general manager of the Phoenix Iron Works Company, has been putting in a few days reorganizing his Chicago office, at 519 Rookery, where he has installed Carey & Shrader as Western Managers.

THE BALTIMORE CAR WHEEL COMPANY, Baltimore, Md., has remembered the REVIEW with a very handsome framed photograph of their "Lord Baltimore" truck, which is a welcome addition to our collection of photographs of street railway apparatus.

A READER of the REVIEW writes us that the Oil City Street Railway, which has been running since Thanksgiving, has six double motor cars of Curtis make and they are making a good record. Four cars are in use and they have not been blocked this winter, "which," the writer remarks, "is saying a good deal."

THE Baltimore City Passenger Railway Company has now under construction a new power house. It will be finished in seven weeks. The new electric lines of the company will be put into operation early in April. The cars have 18-foot bodies, 4-foot platforms, and are finished in ash and bird's eye maple, with double doors.

JOSE ELIGIO MOSQUERA, of Havana, Cuba, has removed his offices and stores to No. 88 Calle del Obispo, that city, where he will continue to keep on hand a large variety of electrical house, telephone, telegraph, electric light and railway apparatus. Mr. Mosquera invites correspondence on all matters pertaining to the above.

THE great and growing Pacific coast electrical industry has necessitated the establishment of a San Francisco agency by the Westinghouse Electric & Manufacturing Company. It will be established in the Mills building and H. A. Russell, assisted by R. B. Elder will be put in charge. Both are well known on the coast and eminently fitted for the work.

THE CHARLES MUNSON BELTING COMPANY, Chicago, has received an order for 141 feet of 60-inch three-ply Eagle Belt, from the American Wire Company, of Cleveland, O. The company put in two 44 inch three-ply belts four years ago and they have been most satisfactory ever since they were first placed on the pulleys. These belts travel 7,000 feet a minute and are subject to very severe strain, but are still in excellent condition.

TWENTY-FIVE new cars, for the Lake Roland Elevated Railway Company, were shipped recently from Elizabethport, N. J., by the Fowler Car Company. They are equipped with the Lord Baltimore four-wheel trucks, made by the Baltimore Car Wheel Company, and have two 25-horse-power motors each. Fourteen are painted orange and black (Baltimore colors), and the others yellow and cream. The former will be used on the Roland Park and Lakeside lines and latter on the Walbrook line. There will be respectively three and five minute service on the lines.

J. F. EASTERBROOK, well known as a former engineer of the Edison Company, and as the designer of several plants, including that of the South Chicago City Railway, has opened an office at 527 Rookery, Chicago, as western representative of J. G. White & Co., electric railway contractors. Mr. Easterbrook combines engineering ability with qualities which make him very pleasant to meet in both social and business relations. We wish and predict for him great success in his new work.

THE WARREN WEBSTER COMPANY, with works at Camden, N. J., and western headquarters at 2 Canal street, Chicago, has just sold to the Pullman Palace Car Company, among other orders, three more Webster vacuum feedwater heaters and purifiers, aggregating 5,000 horse-power. Past orders from this company amount to 2,700-horse-power. The Pullman Company has also bought a system of Williams' vacuum steam heating of the same concern. This will utilize the exhaust steam for heating without back pressure on the engines. This constant increase of orders from such conservative buyers is a great compliment to the worth of the Warren Webster goods.

PROF. W. L. PUFFER, of the Massachusetts Institute of Technology, delivered a popular lecture on telephone receivers recently, before an appreciative Boston audience. In the course of his remarks he stated, that as the result of his trials and experiments with various telephone instruments, he had found the particular receiver telephone of the National Telephone Manufacturing Company to be the most powerful and strongest. He remarked that the two Bell receiver telephones shown were good instruments, but that the National was first. The National Telephone Manufacturing Company is naturally much pleased with such praise from this authority.

C. C. PECK, Rochester, N. Y., has received the contract for the boilers to supply the Detroit city electric light plant, the well-known Peck boiler having been selected after strong competition. The order is for seven 300-horse-power boilers, to carry 165 pounds of steam, working pressure. Each boiler is required to evaporate 9,000 pounds per hour of feed water at 100 degrees into steam at 165 pounds gauge pressure, and to evaporate 10 pounds of water from and at 212 degrees per pound of combustible in Hocking Valley coal. The duty is that of supplying triple expansion vertical marine engines used in running dynamos.

H. F. J. PORTER, who was first assistant mechanical engineer at the late exposition, during its period of construction, and afterwards assistant chief of the machinery department, has formed a partnership with Albert Fisher, formerly Chicago representative of the Ball, Watertown and Green Engine Companies, and together they have opened an office at 1025 Monadnock block, where, under the name of Fisher & Porter, they will carry on a contracting engineering business, in the line of complete equipment of steam plants, giving especial attention to large work. They have been made western representatives of the Providence Steam Engine Company, sole builders of the Improved Green Engine, and of the Altoona Manufacturing Co., builders of the H. A. Green Engine. Thus handling engines of very high grade of both slow and high speed types, they are prepared to meet any demand for first-class work in that direction. They are making arrangements with other eastern manufacturers as agents, and expect to be ready in other lines to take advantage of the incoming tide of business of which they already see indications.

J. L. BARCLAY is now occupying his new business quarters on the sixteenth floor, south end of the Monadnock building, Chicago. The suite of offices are admirably planned for conducting Mr. Barclay's electrical interests, and primarily selected by him for exploiting the sales of the Walker Manufacturing Company's electric railway, and electric power transmitting machinery. The central and western selling departments of that company's business being under Mr. Barclay's immediate supervision. H. McL. Harding, who also represents the above company, has his headquarters for the eastern department in New York. While the general electrical interests of the Walker Manufacturing Company will receive the combined attention of Messrs. Harding and Barclay, all selling business directly connected with the western and middle states will be exclusively transacted at the Chicago headquarters. District and sale agents are now being appointed in the various districts. Among the latter are men who have the confidence of street railway managers, and thoroughly posted in the details of their business. Mr. Barclay feels very much encouraged at the business outlook, notwithstanding the financial depression, inquiries being numerous for the heavy types of generators and motors, such as the Walker Company manufacture.

## PERSONALS.

ELMER HOVEY has been appointed master mechanic at the shops of the Chicago City Railway.

G. J. MELMS, formerly receiver of the Hinsey line, Milwaukee, has returned from a trip through Europe.

H. R. WOODWARD, builder of the first street railway in Peoria, Ill., and president of the line for many years, died recently.

F. E. HANDY has accepted the superintendency of the the Hamilton, Beamsville & Grimbsby Electric Railway. He begins his duties April 1.

F. O. RUSLING, superintendent of the Calumet Electric Railway, Chicago, took the superintendency of the Buffalo City Railway, March 1.

SUPERINTENDENT SLOAN, of Superior, Wis., says: When a woman stands on a corner and frantically waves her parasöl, the street car conductor knows what the wild waves are saying.

BEN WILLARD, constructing electrical engineer of the New Orleans (La.) Traction Company, spent a few February days in Chicago. He is making a magnificent road of the line upon which he is working.

PRESIDENT DANIEL F. LEWIS, of the Brooklyn City Railroad Company, has returned from his trip to the South, made necessary by the attack of the grip from which he suffered. He now feels able to resume his duties.

JOHN R. PAYNE is the constructing engineer of the Middlebrook Street Railway, which is a suburban branch of the Knoxville Street Railway. Col. S. B. Crawford is building the line to develop some valuable acre property. Extensions in other directions are expected.

THE former editor of the Car, of Philadelphia, W. W. Hess, has departed from journalism and become general manager of the Car Equipment Company, of Philadelphia, at 741 Drexel building, that city. The company will be the exclusive agent in the middle, south Atlantic states and Ohio, for the Graham truck, and may probably soon have the territory as far west as the Mississippi. It will also handle the product of the Allen E. & S. Company, the Johnston portable power house hoist, the Johnston oil insulation, and eventually a full line of line material. It will sell also the Ajax metal trolley wheel, bearings, etc., for electrical purposes, in the middle states. We congratulate Mr. Hess upon his new departure, and feel sure that his genial personality will carry forward his new business to success.

JAS. MCBRIER, of Erie, Pa., president of the Ball Engine Company, was a Chicago visitor recently.

## THE BREED TOWER WAGON.

The tower wagon shown in the accompanying engravings is the design of E. S. Breed, general manager of the Central Railway & Electric Company, New Britain, Conn. It has been in constant service on that road for one year, often being bumped over high rails and ties, without damage. It is very light, strong and portable. The highest point when closed is but little above the driver's head. The tower swinging, as it does, from the

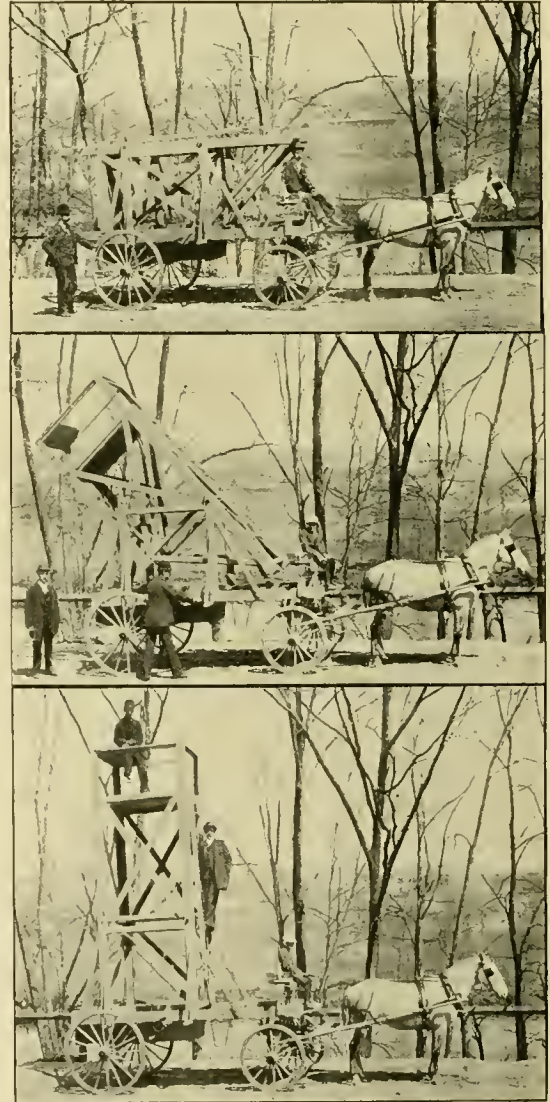

top forward uprights, is thrown ahead when down, so that it hangs over the rear but 2½ feet. The wagon is made of 7½-inch stock and 3x4 timber, and is braced, to be very rigid. It is not a collapsing tower, but a tower swinging on a pivot. It is raised by a windlass geared four to one, and is raised by one man in nine seconds. It is locked in position by a gate hinged in the bottom of the wagon. The driver can leave his seat, raise the tower, and be on top ready for work in less than a minute. On top of the tower railing there is a swinging shelf, which can be used as a platform for getting higher or as a table for tools. When at work it can be swung over the side

of the tower out of the way. The ladder is fastened to the tower permanently. Additional bolts are fastened to the back end of the tower, which are slid through the rear upright. These are used in ordinary construction work as an additional safeguard in holding the tower up, but in ordinary work the hinge gate is all that is used to hold the tower. The lower part of the body is extended downward so that tools can be carried without interfering with the tower.

### A NEW SIGNALING DEVICE FOR STREET CARS.

A device for signaling the conductor of a street car by means of an electric bell is the invention of Robert Thuner, of Detroit, Mich. We illustrate it herewith. The plan is to furnish the connection by means of two copper strips extending around the sides of the car, with terminals at the bell on the platform, and connected with a dry battery. The section shown in the engraving is the molding at the top of the back of the car seat. A is a copper strip  $\frac{1}{4}$  of an inch wide and  $\frac{1}{8}$  of an inch thick. B is the contact strip  $\frac{1}{2}$  an inch wide and thick enough to be resilient. These when in the car are covered by the cloth of the seat furnishing. When a passenger wishes to ring the bell the strip B is pressed into contact. The main idea is that the passenger may sound the bell at any time without leaving his seat. Mr. Thuner says that a car can be equipped at a nominal cost with his device, and that a Detroit car has successfully demonstrated its practicability.

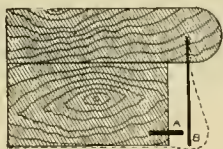

A circuit connection can easily be made between motor car and trailer, or between grip and trailer. The convenience of this arrangement, where one conductor controls two cars, can easily be seen.

The device is simple, strong and positive in action, does not mar the car, and is easily placed.

### OBITUARY.

THOMAS CORRIGAN.

This well-known gentleman and pioneer street railway builder of Kansas City, Mo., died March 1. He was associated formerly with John Scullin of St. Louis, and acquired control of all the Kansas City street railways. These he sold out in 1886 for \$1,000,000. Since then he has not been actively engaged.

ALBERT S. ROSENBAUM.

This well-known Hebrew capitalist died in New York City, February 16, at the age of 63. He was born in Germany, coming to this country at an early age and settling in California, where he made the greater part of his money in real estate. He was a prominent director in the Third Avenue Railroad Company with large holdings in other New York surface roads.

### A BLOCK SIGNAL FOR SINGLE TRACK ROADS.

Very often in the operation of single-track roads there is much difficulty from meeting between the turnouts, and even on well regulated roads the delay of one car means the delay of all the others. H. J. Wightman & Co., of Scranton, Pa., are making a block signal for single track roads which is automatic in action and does not introduce prohibitive complications. As the trolley wheel passes the signal hanger, shown herewith, it enters between the trolley clip and the signal lever, raising the latter and closing a contact inside the case. This causes a signal to be established at both ends of a stretch of single track. The near signal indicates to the motorman that

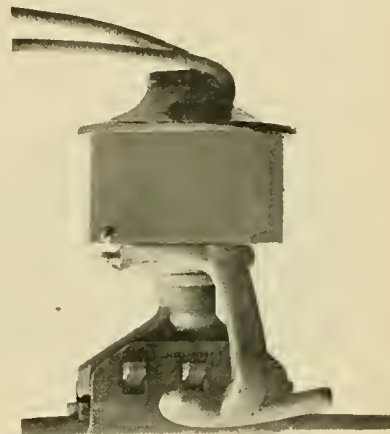

he has thrown the danger signal at the other end, thus giving him the right of way. The signal remains established until a similar hanger is passed at the other end of the block. The signals themselves may be either colored incandescent lights or semaphores. But one line, usually a telegraph line, is needed to signal in both directions. A bell may be included in the signal circuit. The same signal system may be used on crossings, to advantage.

THE lamented death of Mrs. Josephine Smith, of New York, on February 23, who for so many years has been the principal of the large business conducted under her name, leaves the entire charge and interest in this large business to Charles G. Smith, her son. Mr. Smith, whom all of our readers know as the conductor and general manager of this concern, will continue the business at the same address and in the name of Charles G. Smith.

NEGOTIATIONS are in progress between the town council of Cornwall, Ontario, Canada, and Mr. W. R. Hitchcock, who is seeking a franchise to operate an electric street railway to carry both passengers and freight. It is proposed to form a company for this purpose, and utilize power from the Cornwall canal.

THE New Orleans (La.) Electric Club has elected the following officers for 1894: Professor Brown Ayres, president; H. J. Malochee, secretary and treasurer, and William Oswald, E. Leloup, G. A. Hopkins and B. V. B. Dixon, managing committee. The club discussed the street railway return circuit, upon which subject Mr. Malochee read a valuable paper.

EXHIBITS AT ATLANTA CONVENTION.

Arrangements for the comfort of delegates, and the success of the annual convention of the American Street Railway Association, at Atlanta, are not being forgotten, and the several local committees already have accomplished a great deal.

feet, with a wing at one end 64 by 74 feet, in which the sessions will occur. Exhibit space has been plotted as shown in the diagram and applications are already being made and exhibitors will do well to apply at once. A railroad track and unloading platform extend nearly the entire length of the building and better facilities than ever before are thus secured. One-half the building is sup-



MACHINERY HALL, WHERE CONVENTION WILL BE HELD.

Exhibitors whose interests are large will have specially to do with L. R. Shellenberger, Equitable Building, Atlanta, and who as southern agent for the Johnson Company, has a large and pleasant acquaintance in the fraternity. Mr. Shellenberger is chairman of the local

plied with shafting and steam power, and there will also be an abundance of electrical power at hand. The probability is a larger number of exhibits than ever before will be shown in actual operation.

Machinery Hall is in the beautiful Piedmont Exposition

American Street Railway Association Exposition.

floor plan

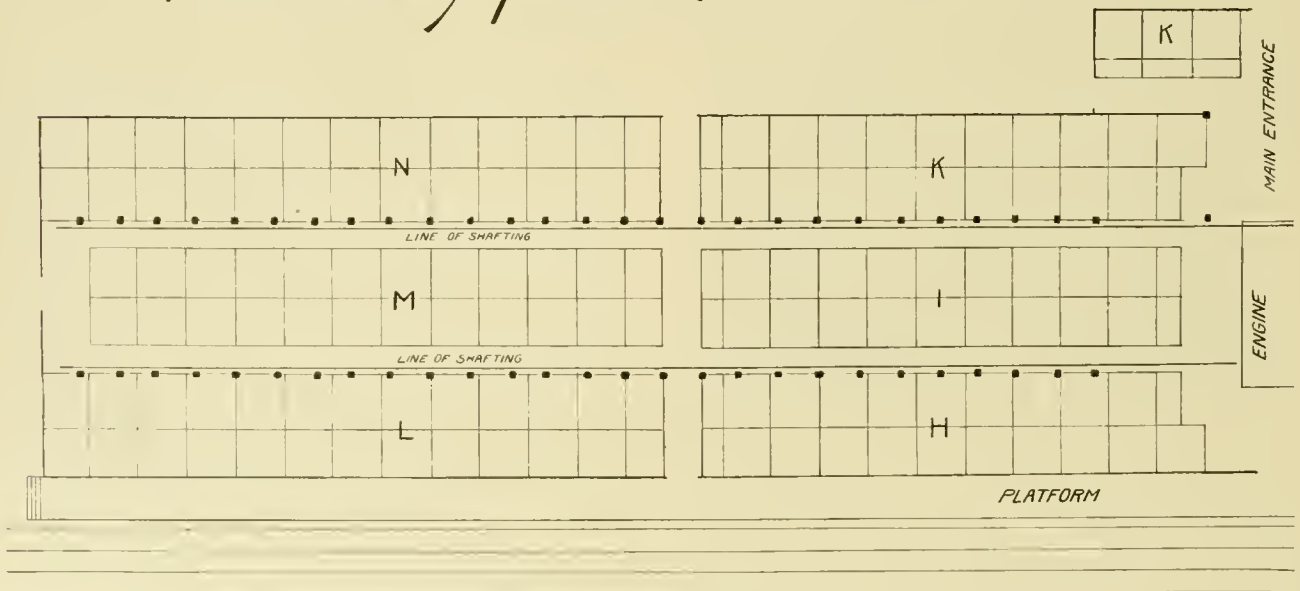

committee, which has the exhibits in charge, and as previously announced in the REVIEW, both sessions and displays are again to be under the same roof, an arrangement most devoutly to be desired. The building selected is Machinery Hall, the dimensions of which are 74 by 520

feet, with a wing at one end 64 by 74 feet, in which the sessions will occur. Exhibit space has been plotted as shown in the diagram and applications are already being made and exhibitors will do well to apply at once. A railroad track and unloading platform extend nearly the entire length of the building and better facilities than ever before are thus secured. One-half the building is sup-



HEADQUARTERS HOTEL.

The committee could not have made a better selection in its choice of headquarters than in the magnificent Hotel Aragon, representative of the most complete and modern hostelries in the country. It is beautifully located at the corner of Peachtree and Ellis streets, and is honored with the presence, in the same block, of the Grand Opera House, the Governor's mansion, and the Capital City Club. The hotel embodies every known improvement tending to promote comfort and elegance, and was completed only last November. The Association, therefore, will enjoy its elegance and beauty while

FROM the Risdon Iron & Locomotive Works Company, of San Francisco, comes this commendation of Charles A. Schieren & Co.'s belting. The Risdon people write, as follows:

"The two double perforated electric leather belts purchased of you last summer for the Union Ice Company's factory, Mentone, San Bernardino County, Cal., are doing splendidly. The 20-inch belt on 26-inch motor pulley has a velocity of about 5,000 feet per minute; the 30-inch belt has a velocity of about 3,000 feet per minute. Each transmits 1,500 horse power, and both are as perfect as when first put on."

Atlanta Ga.

October 17.18.19.1894.

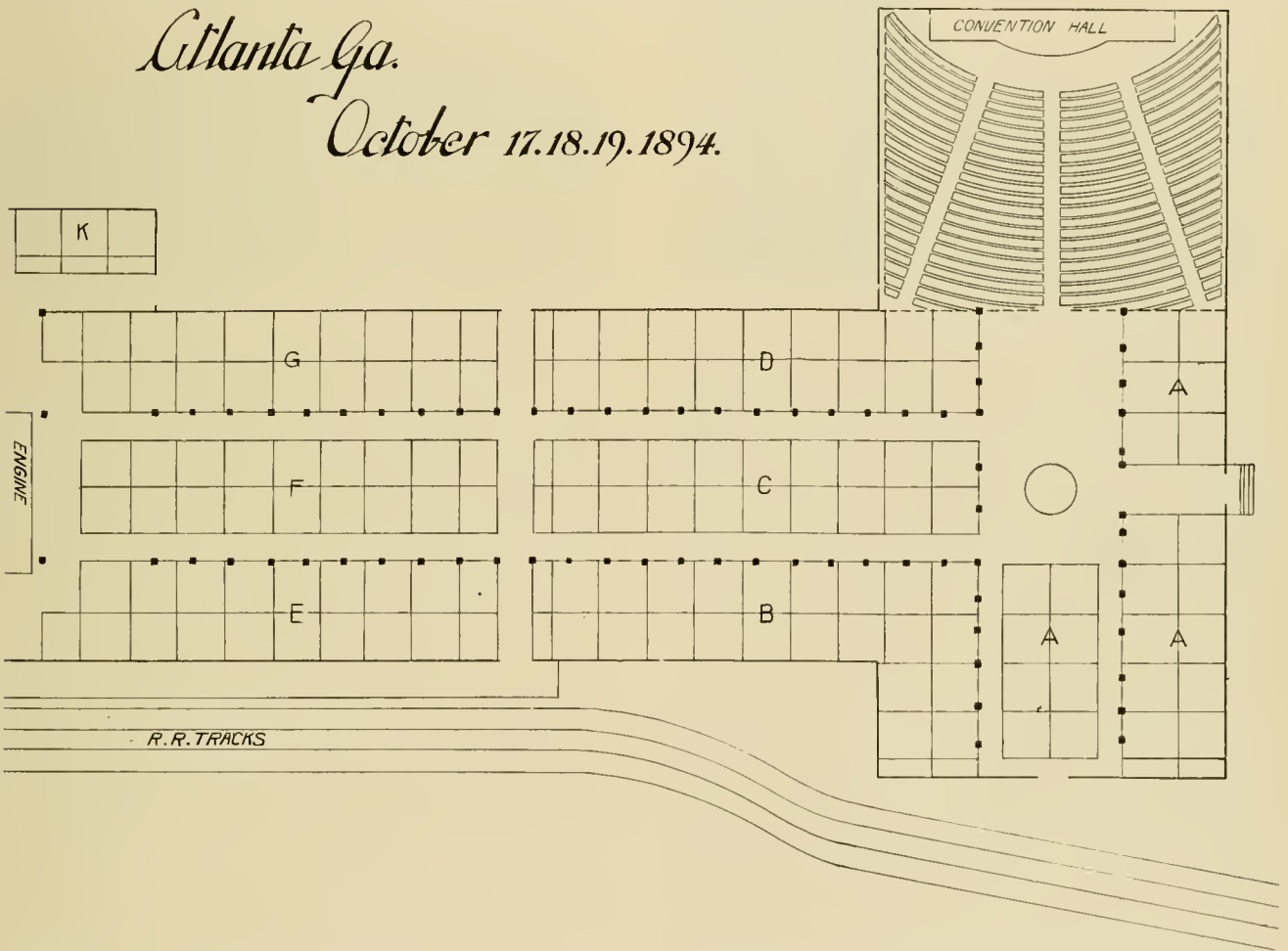

it is still fresh and new. The building is six stories, in Spanish-Romanesque style, with first story of Georgia marble and the other five of pressed brick and terra cotta. The house is fireproof, the public and private rooms are richly furnished, and the cuisine is justly famed for its excellence. The house is conducted on both the American and European plan.

Delegates will do well to make application at once for desired accommodations, as the attendance at convention this year will be larger than ever. Many have already secured rooms and, from their orders, it is evident that visitors are coming from one to three days in advance in order to have more time to enjoy the beauties of this charming southern city. All applications for rooms should be sent to the Hotel Aragon, Atlanta, Ga.

YOUNGSTOWN, O., has just gone through a miniature street railway riot. It seems that manager A. A. Anderson was thoughtless enough to want to run his own road and the fifty or sixty employes objected as a union. In consequence, non-union men were put to work, and the riot ensued. Fifty of the new employes were besieged in the power house by the strikers and sympathizers.

THE TECHNIC, the engineering annual of the University of Michigan, is again making its yearly rounds and is full of information of practical value. Safety Fuses and "Heating a Shop for Nothing" by exhaust steam, are articles of special interest in our line.

J. H. CARSON, of New York City, has been in the city for the past week.

## THE DAVIS SHADES AND HOLDERS.

Among the luxuries of modern street cars the cloth shade, with its ease of adjustment, is one of the foremost, and in the front rank of cloth shades is found the Davis. The Davis shades all have automatic fasteners, which enables the placing of the curtains at any height, instantly and without trouble. This method of fastening makes it also possible to employ a strong roller spring, which will practically never wear out. Probably the most popular style of fastener for street car use is the "pinch

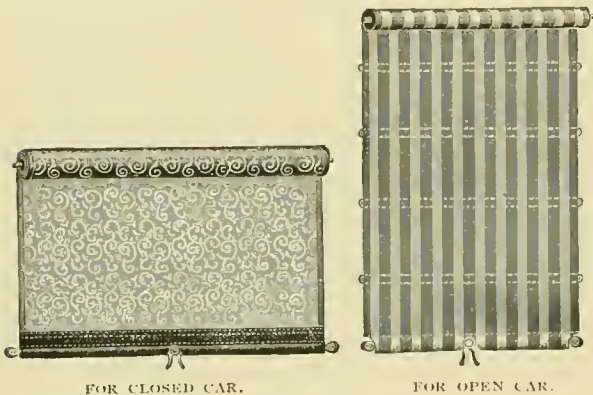

FOR CLOSED CAR.

FOR OPEN CAR.

handle" herewith shown. It does not require an expert on shade fastenings to find out how to work the curtain with this device. The company also makes a turn button handle for places where the curtain must be brought clear down to the sill. The open car curtain is another neat and substantial improvement. The edges are held to a rain tight fit by bars, the ends of which extend into the grooves. These curtains are as far ahead of the "furred up" kind as the electric car is ahead of the horse car. The 250 cars of the Peoples Traction Company, of Philadelphia, will have the Davis shades.

THE JOHN STEPHENSON CAR COMPANY, LIMITED, of New York City, has just received as a second order, a call for fifty more open cars for the Metropolitan Traction Company, of New York. These, with other smaller orders bring up the car works to full force and full time.

MANAGERS of steam roads have looked with no small jealousy upon the innovation caused by the inter-urban electric railway. But, we believe, that feeling is gradually but surely giving way to the better judgment, that constant advance in all avenues of business is the inevitable, and that even there may be more gain than loss eventually from this new and popular competition. The cabmen hailed the first street car as the hearse which was to carry to its last resting place the dead body of their vocation. But is there any less number of hacks, cabs and kindred conveyances to day than ten years ago. So with the inter-urban. It will undoubtedly lessen local passenger traffic in certain localities at first, but it will also act as a feeder and make possible the shipment on steam lines of much perishable freight not now cultivated for lack of transportation to the railroad, and give two for every dollar it takes.

## REPAIRING ELECTRICAL APPARATUS.

The equipment of the Stanwood shops stands ready on short notice to repair any description of electrical specialties, from the most delicate testing instrument to the heaviest type of generator, and from the most simple to the most complex light or transmission of power apparatus. Special provision is made for street railway work, with complete facilities, skilled labor and prompt attention. The superintendent of the electrical repair department is Mr. Earl Atkinson, whose long and varied experience in building and repairing electrical machinery and apparatus of all kinds, makes him specially suited to the direction of the work mentioned. He was born in Canada in 1864, and at the age of seventeen began his mechanical career in the machine shops of Inglis & Humber, engine builders, Toronto. A year after his apprenticeship was served, he went into the Ball Electric Company's shops, Toronto, where he received his first introduction to electrical work. In 1888, Mr. Atkinson went to New York City, and after a short employment became foreman of the Marine shops of the Chas. Delamater Iron Works. After the death of Mr. Delamater, Mr. Atkinson went into the Edison laboratories at Orange, N. J., where he became head of a department. In 1892 he came west with the Edison General. After some time in this and kindred work, Mr. Atkinson accepted the flattering offer of his present association, and took charge of the electrical department of the Stanwood Manufacturing Company, of Chicago, where he is to-day, with a thorough knowledge of theory and practice and a wide acquaintance with the street railway needs.

## NEW PUBLICATIONS.

THE OHIO BRASS COMPANY, of Mansfield, appears with its catalog No. 2 of street railway supplies. Although it is for the first time dealing directly with the users of its apparatus, it has been manufacturing this line of goods for a large supply house for several years, so that it is no novice in the business, as is also indicated by the completeness of the catalog.

THE crimson and gold of the Taylor Electric Truck Company's 1894 catalog is adorning the managers' desks throughout the country.

THE growth of the Garton-Daniels lightning arrester business is best illustrated by a 20-page catalog of descriptive matter and testimonials, issued by that company in this the ninth month of its corporate existence.

DICK, KERR & COMPANY, of London, have issued their February (1894) catalog, describing the many types of gas engines made by them.

ENGLISH METHODS OF STREET RAILWAY TRACK CONSTRUCTION, by James More and Alex. McCallum, Street Railway Journal, New York, 26 pages. Price 35 cents. A description of English as compared with American methods, with criticisms of both. The treatise is a very fair one on both sides, considering that the authors are from the other side of the water and not well acquainted with American conditions.

THE fifth annual report of the inter-state commerce commission is issued, appearing six months earlier than any previous edition. It is for the year ending June 30, 1892. We are informed that a large part of the delay is a fault of the railroads. The report cannot fail to be of value to steam roads and contains much data of interest to street railway men.

## AN ILLUMINATED CAR SIGN.

An illuminated sign for showing car routes is being put on some of the cars of the Cleveland Electric Railway, and is appreciated very much by the night-traveling public. It is attached to the dash of the vestibule. The sign consists of a box, covered on the front side by a glass slide and containing a 20-candle-power incandescent lamp. The box is made of galvanized iron and is 21 inches long, 11 inches wide and 4 inches deep in the center. The back corners of the box are tapered off to allow the hooks, by which it is fastened to the car, to be placed on the back of the box and not have the box pro-



ject too far out from the dash. A small block of wood is bolted to the bottom of the box on the inside and the lamp socket is fastened on this block. The lamp is taken from the hood of the car and the wire is extended from there to the box on the front of the vestibule, so that no extra lamp is used. The outside of the box is painted the same color as the car and the inside is painted a dark color. A glass slide is fitted into the front of the box and the name of the line is painted on this slide in white letters on a dark ground. A double sign may be made by putting on a tin door which turns on a hinge across the center of the box. This door when turned up covers the upper part of the sign and when turned down covers the lower part. This double sign is used on a through line in Cleveland, the name Wade Park being covered when going to Brooklyn, and Brooklyn covered when going to Wade Park. The name of the line is easily read at a distance of two or three hundred feet. The sign was designed by John J. Stanley, general superintendent, and is made in the company shops. It is possible to have the lettered slide of tin with perforations for the letters.

## TRACTION BUYS TRANSIT.

One of the largest consolidation deals of this year is the combining of the Allentown & Bethlehem Rapid Transit Company with the Lehigh Valley Traction Company, both of Pennsylvania. The rapid transit company was backed by Ex-Governor Ames, of Massachusetts, and other Bostonians. Congressman Tom L. Johnson and A. L. Johnson, of Cleveland, are at the head of the Lehigh Traction. The price of the rapid transit company is said to have been \$1,250,000.

Jilson J. Coleman will be general manager of the combination and an extensive scheme of interurban roads is planned.

The concerns or corporations consolidated are: The Allentown Passenger Railway Company, capital stock \$200,000; the Bethlehem and Allentown Street Railway Company, capital stock, \$100,000; the Bethlehem and South Bethlehem Street Railway Company, capital stock \$200,000; the Catasauqua and Northern Street Railway Company, capital stock \$75,000; Allentown Electric Light and Power Company, capital stock \$150,000 preferred, and \$150,000 common; and the Rittersville Hotel Company, capital stock \$100,000. The capital stock of the Rapid Transit Company is \$1,500,000. The directors of the Traction Company are A. L. Johnson, Tom L. Johnson, Howard Page, Jilson J. Coleman, W. J. Hartzell and M. L. Kauffman.

## STREET RAILWAY PATENTS.

Compiled by the Street Railway Review.

ISSUED FEBRUARY 13, 1894.

Track drill. Louis J. Crecelius, St. Louis, Mo, assignor to Andrew Warren, same place.....	514,544
Electric railway. Paul W. Lefler, Minneapolis, Minn., assignor to the Lefler Electro-Magnetic Railway Company, Chicago, Ill.....	514,561
Bond wires for electric conductors. Alfred Hoffman and Joseph Brogan, Milwaukee, Wis.....	514,714
Electric railway system. Paul W. Lefler, Minneapolis, Minn., assignor to the Lefler Electro Magnetic Railway Company, Chicago, Ill.....	514,718
Life guard for street cars. Theophile Euphrat, Darien, Conn.....	514,749
Trolley. John A. Williams, Altoona, Pa.....	514,801
Electric railway conduit. Robert I. Hampton, Athens, Ga.....	514,827
Electrically operated street indicator for cars. Henry C. Barker, St. Louis, Mo., assignor to Jacob Stocke, Jr. and Henry C. Beekman, same place.....	514 878

ISSUED FEBRUARY 20, 1894.

Trolley wire support. Rudolph M. Hunter, Philadelphia, Pa., assignor to the Thomson-Houston Electric Company of Connecticut.....	514,932
Electric railway system. Nikola Tesla, New York, N. Y.....	514,972
Automatic grip opener. William P. Courtney, Oakland, Cal., assignor one half to Albert Brown, same place.....	515,115
Railway switch. Ernest Leighton, Boston, Mass.....	515,122
Railway switch. William F. Stedman, Boston, Mass.....	515,135
Safety car fender. William J. Ogden, Baltimore, Md.....	515,157
Trolley conductor and support. Myron D. Law, Washington, D. C., assignor to Albert G. Wheeler, Chicago, Ill.....	515,238
Indicator for electric cars. Henry C. Beckmann, St. Louis, Mo.....	515,274
Electric railway trolley. Chas. J. Van Depoele, Lynn, Mass. C. A. Coffin and Albert Wahl, administrators of said Van Depoele, deceased, assignors to the Thomson-Houston Electric Company, Boston, Mass.....	515,208

ISSUED FEBRUARY 27, 1894.

Electrical controller. Elmer A. Sperry, Cleveland, O.....	513,374
Tramway switch. Simeon L. Cole, Brooklyn, N. Y.....	515,356
Car brake. Henry H. Sessions, Chicago, Ill., assignor to the Pullman Palace Car Company, same place.....	515,555
Street car. Thomas H. Wickes, Chicago, Ill., assignor to the Pullman Palace Car Company, same place.....	515,567
Conduit electric railway. Joseph A. Cassidy and William A. Butler, New York, N. Y.....	515,572
Safety car fender. William R. Fowler, Baltimore, Md.....	515,581
Safety attachment for street cars. Henry A. Howe, Albion, assignor to himself and Joseph Norwood, Brooklyn, N. Y.....	515,588
Street car fender. Walter W. Peay, Toronto, Can., assignor to John Henry Banes, same place.....	515,609
Electric railway. Benjamin F. Comstock, Decatur, Ill.....	515,654
Fender for street cars. William H. Brock, Brooklyn, N. Y.....	515,728

### THE COMMON SENSE SAND BOX.

For some time the ingenuity of our inventors has been taxed to produce a sand box for the use of street railway lines, and the need has been emphasized by mechanical traction. Many have been devised that did good work under favorable conditions and possessed many points of excellence, but were not up to requirements. The com-

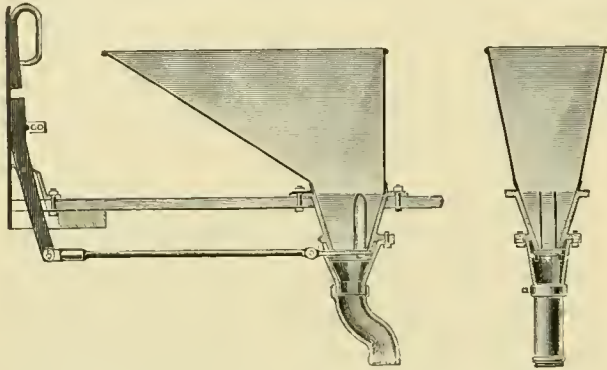

mon sense sand box is one of the latest and best offered. It is simplicity itself, and very easy to manipulate. Certainty of delivery is ensured by the knives attached to the gate, which thoroughly cut the sand, even if it is packed hard, and brake it up so that it flows perfectly. The sand is carried in a hopper, which is firmly attached to the floor, and lined throughout with galvanized iron. The size now in use holds a bushel. The sliding gate is of hard bronze, and the knives tempered steel. A locking device attached to the dashboard will hold the gate open or shut, or at any intermediate point. Cars are equipped with either two or four boxes, and they can be arranged to operate by either lever or foot power, as desired. The makers, E. F. DeWitt & Co., of Lansingburg, N. Y., have received very flattering testimonials, and the number of orders on the books is something remarkable, considering the short time the company has been in the business.

### CURTIS MOTORS FOR BROOKLYN.

The Curtis Electrical Company have just closed a large order for street railway motors with the Brooklyn City Railway. There has been a hard fight for this business and in obtaining the order the Curtis people naturally take justifiable pride that the record already made on that road, of forty of their equipments, should have been so satisfactory as to command a second and much larger purchase. The new contract calls for 120 equipments, which are to be delivered as rapidly as the works can turn them out.

MILTON H. HAMILTON, widely known in electrical and railway circles, died in Pittsburg on March 10. He was formerly chief clerk for Wm. J. Clark, of the General Electric, the news of his death will cause widespread sorrow and regret.

### THE CALDWELL STANDARD WATER TUBE BOILER.

The Caldwell water tube boiler, made by the Link Belt Machinery Company, of 21 South Jefferson street, Chicago, has a number of peculiar features of merit which are here illustrated. It is not necessary to enlarge on the advantages of water tube boilers and the safety and economy of this type, for this is already too well known to need repetition. One of the prominent advantages of the Caldwell Standard is the use of fire brick between the tubes. These are called baffle bricks and are for the purpose of directing the heated gases against the tubes. In addition to this they store a limited amount of heat, which is given out when the furnace doors are opened or the fire temporarily cooled, and gives the boiler a steady heat. It is, in fact, a kind of thermal storage, which prevents too great expansion and contraction. There are no joints in direct contact with the fire. The construction is such as to insure a rapid circulation of the water in one direction. By removing a single header cap an indication of the state of every header and tube is

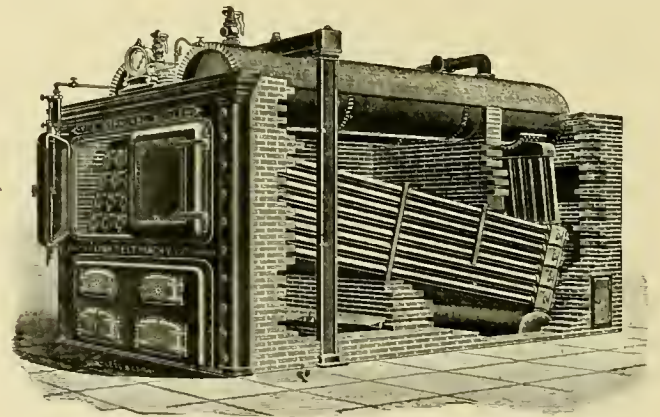

had. One tube or every tube can be removed from the front openings in the headers. George H. Barrus has recently made some exhaustive tests on this boiler, and under ordinary running conditions obtained an evaporation (with the regular fireman) of 11.3 pounds of water per pound of combustible, with a semi-bituminous coal. When forced 66 per cent above its rated capacity the moisture was only  $\frac{1}{1000}$  of one per cent, a result seldom obtained in this class of boilers.

EDWARD J. LAWLESS, formerly superintendent at Paterson, N. J., has been appointed agent of the American Car Company, at 109 Liberty street, New York.

AN affidavit has been filed by President C. C. Bonney, of the Twenty-second street line, giving evidence in the Siemens-Halske injunction suit. The electric company accuses the railway company of using current for experimental purposes. The affidavit tries to give proof that the Siemens-Halske Company should be restrained from cutting off the power supply.



WINDSOR & KENFIELD,  
 PUBLISHERS AND PROPRIETORS,  
 269 DEARBORN ST., - - - CHICAGO.  
 Published on the 15th of each month.

SUBSCRIPTION, - - - TWO DOLLARS.  
 FOREIGN SUBSCRIPTION, - - - 20 SHILLINGS.

Address all Communications and Remittances to THE STREET RAILWAY REVIEW,  
 269 Dearborn Street, Chicago.

H. H. WINDSOR, Editor. F. S. KENFIELD, Business Manager.

**CORRESPONDENCE.**

We cordially invite correspondence on all subjects of interest to those engaged in any branch of Street Railway work, and will gratefully appreciate any marked copies of papers or news items our street railway friends may send us, pertaining either to companies or officers. Address:

THE STREET RAILWAY REVIEW,  
 269 Dearborn Street, Chicago

Eastern Office, Room 14, No. 126 Liberty Street, New York.

This paper member Chicago Publishers' Association.

Entered at the Post Office at Chicago as Second Class Matter.

VOL. 4. APRIL 15, 1894. NO. 4.

WHAT will you have this summer as a means to create travel?

THE interurbans have made a splendid record the past winter, and all report a good business.

INDICATIONS all point to an early, and greatly improved movement over last year's summer travel.

MUTUAL insurance is more and more forcing itself upon the street railways of the country. Underwriters pronounce railway risks poor policies, but they are not half so bad as the short sighted policy which seems to prevail among insurance men.

HERE is something which for absolute originality properly deserves the attention and comment, English journals are devoting to a new invention. It is called a "tram car starting apparatus" and stores energy in a wound up spring. The nearly 1,000 wound up inventors in this country which have sprung such "apparatuses" on the much afflicted manager, need not have any fears that the English starter will get much the start of them.

DID the editors of the New York and Brooklyn daily papers ever think what a ridiculous attitude they put themselves in by publishing accounts of the recent episode on a bridge in Brooklyn, in which a deputy sheriff had to be given the full benefit of a 500-volt shock, three times before he would let go the heads of the tower

wagon horses? The publication of this one incident knocks the props out of all the deadly trolley matter they have ever published.

THE street railway, at Bristol, England, has lost over 100 valuable horses and others are daily increasing the loss. The unfortunate animals are suddenly taken with paralysis, and the veterinarians seem unable to cope with the disease which has been traced to a poisonous Indian pea vine which was mixed in imported fodder. The poison works in a cumulative manner, hence it is impossible to tell for some time where the loss will stop. The present is an excellent time for the Bristol management to consider electricity as a motive power which does not short circuit on Indian peas.

THE absorption of street railways by English municipalities is the continued and growing subject of interest in that country. Unless conditions are very radically different from those which prevail here, we predict that five years will fully establish the mistake. Even so conservative and certainly reliable an authority as Engineering, of London, states:—"Certainly, private companies have worked the tramway system, generally speaking, more satisfactorily; and it were well that corporations should carefully weigh all considerations before entering upon enterprises simply because they conform to present ideas as to municipal socialism."

THERE'S a chance for some manager having a line running out four or five miles, to make up excursion trains of say three cars on warm summer evenings, and distinguish himself by putting music on board. This would add to the charm of the ride, and as it is purely for pleasure the music would be a strong attraction. We expect some day to see a dining car hooked on to the rear of the train, where electrical ice cream and storage battery cakes will be served en route, together with current "juice" and other light fixtures. While the liability to sparking would be increased, a proper system of feeders would doubtless secure good results.

THE official photographer of the Midwinter Fair has learned well his lesson from he of Chicago picture fame, and gone him several better. Ever since the Midwinter was opened, the REVIEW has made strenuous efforts to secure a set of views of the principal buildings, but without avail. When the show was a novelty we were willing to be bled, but even money was no object to them then and views could not be had at any price. Now that the event has almost become history, the artist man has so far relented as to allow publishers to obtain certain views by paying ten dollars each, in addition to an outrageous price for photography, but the conditions of use are such as to be practically prohibitory. Evidently there is some reason why the managers of the western fair do not care to have the world know or see that for which they have made so extravagant claims. Such treatment is very poor return for all the kind words and free advertising the press has afforded the California effort.

THE annual report of Superintendent Curtin, of the Milwaukee Fire Insurance Patrol, is an interesting document, and adds further evidence to the great increase in risk (!) where trolley wires are run. During the year just closed there were in that city 645 fires, of which smokestacks caused 22; furnaces 28; gasoline stove explosion 26; oil stove explosions 20; overheated stoves 41; while there were only three fires from electric wires, each of which were from lighting wires. Milwaukee certainly is well lighted electrically with both arc and incandescent systems, and has nearly 100 miles of trolley wires. The arc circuits are manifestly more dangerous risks than motors fed from railway circuits, and the insurance records show greater reason to refuse residences containing furnaces than buildings where the railway current is used for power. The insurance companies are radically wrong in their discrimination against railway circuits and the sooner they change front on this question the better off will they be. There has been a long stride in mutual insurance in the past three years, and the way the several State street railway associations, are going into the subject make it strongly probable something will come out.

SENATOR COGGESHALL, who has a bill before the New York legislature limiting the speed of trolley cars to six miles an hour, should change his name to Clogs-all. So wretchedly absurd and senseless a measure deserves to be relegated to a way back past, out of which the senator seems to have come bringing its fossilized traditions with him; rather than be dignified with even mention or objection. To be consistent, steam railroads should come down to 20 miles an hour, and carriages to four; the fire and police departments to a walk and mail wagons to the speed of the average messenger boy. In these days of improvement the public will not submit to street car travel at a pace which is not considered improper even for a funeral procession. It's the same old story again; legislation can never be sufficiently elastic to cover it, for at times six miles an hour may be dangerous where ten minutes later ten or twenty would be safe. The decision within reasonable bounds must be according to circumstances, and of these the man in charge of the car is competent to be the judge, for no man should be in charge of a car who is not. The scheme savors of the old school blackmail which is levied on corporations once in so often.

THERE was a strike in Youngstown, O., which the citizens thought rare sport, and better than a circus to see the ex-employees cut trolley wires and indulge in the regulation mob and riot violence. Now that the ball is over, and there is a thrifty possibility that the fiddler will send in a statement, the faces which wore a watermelon smile at the sight of wanton destruction of the railroad property, begin to lengthen like a February icicle. The corporation has been taxed, and taxed heavily, to support the police and fire departments and pay salaries of men whose oath bound them to maintain law and order and protect the lives and property of the Youngstown citi-

zens. The officers particularly neglected to do so in the instance mentioned, and good lawyers assure the company they have the clearest kind of a case for damages against both city and county. City officials, in this gloriously free country seem to be imbued with the idea that taxpayers are created and allowed to exist for the sole and express purpose of furnishing money for the aforesaid c. o. to fatten on; but the fact remains, though little recognized, that the taxpayer has rights guaranteed him by state and national constitutions, which, "though lost to sight," are "to memory dear."

MERRY music is already borne to us on the salt breezes of the Atlantic, from English municipalities, which have secured control of the street railways, and having done so do not know how to conduct them except at a loss. That more such results will follow is to be expected; not because the city is in England, for the same outcome should be looked for in any country. Witness the following extracts from the Western Morning News, of Plymouth, in commenting editorially on a meeting of the city tram car committee. It says:

"Less and less are the rate payers of Plymouth allowed to know of what their representatives in the Council are doing, and nothing at all as to the reasons for what is being done. Witness the reports published to-day of yesterday's meeting. Every report presented yesterday was adopted, with nothing approaching a debate, or clear explanation of the why and wherefore. There was a little talk on the proposal to put £200,000 more of the Corporation Stock on the market, and just a little criticism of the tramways' working, which is admitted to cost the rate payers £100 a month, although this loss might be avoided if reasonable fares were charged. But this is to be made up by charging the Chamber of Commerce an extravagant rent for indifferent accommodation, and against this not a word of protest was raised. And so the ball rolls merrily on."

SUIT was brought in San Francisco against one of the roads for \$30,000 damages. When the jury had been summoned, the plaintiff concluded to abandon the case, the effort to bluff the company into a settlement having proved futile. The judge took occasion to reprimand the lawyers, stating the county had been to an expense of nearly \$100 in calling in men to serve on jury for the case, and that the county had some rights which even litigants were bound to respect. The fact is, our system of legal procedure in damage cases is radically wrong in most states and offers alluring inducements to blackmailers and shyster lawyers. The former have all to gain and nothing to lose in case of defeat—not even reputation in many cases—while the unscrupulous lawyer struggling after practice welcomes any kind of a case which will get his name on the calendar before the public and afford him that same opportunity for legal exercise which doctors find in the dissecting room. There is little wonder that the temptation is too strong for many men whose sense of honor is not abnormally developed. The remedy for this, for there is a remedy for much of it, is in the enactment of such laws as will make the party

bringing suit liable for the court costs in case of defeat. Where defendant loses he now usually is saddled with costs also, but it is a very one-sided deal.

THE past thirty days have shown a decidedly marked improvement in street railway orders, for both repair and construction material, and the outlook for manufacturers in our field is quite encouraging. More new lines are going forward on Eastern than Western roads, for the reason that prior to the depression greater progress had relatively been made in the West, while the more conservative management of the East waited, and now find a certain and unmistakeable demand and insistence on the part of the public for betterments which were anticipated in the West. There is, however, a large volume of new construction planned for the middle and western states, and in Chicago alone, the equipments to be ordered in the near future will be surprising. Extensions of present systems and renewals and betterments in rolling stock and stations will, in the aggregate, reach high figures and create a large demand. Money is getting easier every day, and companies have in many cases completed plans and estimates and only await the necessary funds. The fact that operation during the past unfavorable year has been as successful as it has, is having a strong effect in many localities in securing locally much capital which formerly was obtainable only in the East. Altogether the indications point to a large demand for railway supplies of every kind. Dealers have generally adopted the much better plan of refusing the long credits which were resorted to formerly in their anxiety to force business, and buyers are recommended to purchase only what they can reasonably expect to settle for in sixty and ninety days at the longest. The bad effects of an abnormally large business, arising from having induced a manager to extend and equip on too close margin of successful operation, was pointed out in these columns long ago, and now that the business-like system of filling orders instead of creating them prevails, both buyer and seller will be better served in price and quality.

CONGRESSMAN WALKER, of Massachusetts, on the floor of the House, made a fair sample of himself of what the average intelligence of our present-day lawmakers is, on so important a question as is involved in street railway interests. The gentleman was decrying the trolley system, (which in his own state carried 93,000,000 more passengers last year than its steam railroads), and attributes the remonstrance of trolley interests in the District of Columbia against being put to death, as due to the fact that the two great electric manufacturers could sell to greater profit for overhead than underground construction. The gentleman, however, neglected to point out in what respect any underground system required a less number of motors to equip the cars; or generators to produce the current to propel them; or feeder wires to conduct that current; or engines and boilers for power house. He might have mentioned the saving of 500 cedar poles per mile, although we were not aware that

poles formed one of the highly profitable of the diversified crops of an electric manufacturer's farm. But throw the poles off the track and the manufacturers have more to sell an underground road than any other system. What the benighted representative ought to know, is that a legitimate road of any kind, even an old fashioned toll road, is limited to the possibilities of its maximum earning capacity; and this earning capacity is restricted to the number of people tributary to the line who can afford to ride. The track construction for underground electric is nearly or quite as costly as cable conduit, though the power house installation is somewhat in favor of electricity. But in either case a heavy business is essential to warrant the first cost and its consequent interest. While there is an undoubtedly large field for conduit electric there are 50 miles of street railway track where the expense is absolutely prohibitory to one where it is warranted. Trolleys will doubtless continue to skim the overhead wires long after Mr. Walker has ceased to be either a walker or a talker.

#### FOREIGN FACTS.

CAR lighting by gas is being tried on the South London Tramway Company's lines.

VIENNA had a tramway strike March 15, in which one car was wrecked by the strikers.

BARCELONA is up to date, with a horse car run down at a railroad crossing, in which four passengers were killed and eight severely hurt.

THE omnibus men of London are always in trouble or about to strike. The men have to work from 16 to 17 hours a day and are paid \$5 a week.

THE Buenos Ayres & Belgrano tramway, in 1893, earned £43,484; spent in operating, £30,096; leaving a net profit of £13,388. A good showing.

THE STOCKHOLM-DJURSHOLM Electric Railway is about completed and several portions of it already tested and approved by the government. The power plant is ready for work.

ENGLISH correspondents to London papers are loud in expressions of praise for American street traction and rapid transit, at the expense of the London underground steam and surface tram cars.

L'ELETTRICISTA, the most prominent Italian electrical technical magazine, published at Rome, is devoting increasing space to traction, which is becoming a prominent feature of Italian electrical engineering.

AN electric tramway, over three miles in length, is being constructed at Bordeaux, France, on the Thomson-Houston system. Six cars will at first be put into service. The station contains Babcock and Wilcox boilers.

## ELECTRICS IN THE CRESCENT CITY.

France in America—Sights in the Creole Section—Romantic History of the City—Gigantic Undertaking of the New Orleans Traction Company—Plans for a Model Modern System.

Probably no city in the United States combines more features of interest to the traveler, business man and student than the Crescent City, the great metropolis of the South; whose history constitutes a story of matchless interest, and whose name and progress are closely interwoven with nearly all the great events of national moment. Here are presented contrasts as cannot be found in any other city in all our land, for while the great French quarter is as distinctively foreign as any city in France, one has only to cross a single street to enter that portion of the city known as the American section, where art, literature and culture in its highest form prevails, with modern and American ideas of life and architecture. The visitor however is surprised to note the evidences on every hand in both the old and new city, of wealth; for hundreds of Creole families enjoy a life of luxury which accompanies the possession of large estates, and in their conversation and social and business life give unmistakable evidence of that descent which has given them the title of the "Knickerbockers of Louisiana." In passing in may be stated here that "Créole" as usually interpreted in the North is quite erroneous, and in its proper and best sense means, not a mixture of Indian, mullatto or negro and white; but those American born of French or Spanish parents, and signifies only one of pure and unmixed European blood. A clannish feeling of remarkable strength and pertinacity exists among thousands in the old city, the dividing line being Canal street, which in early days was a fortified moat and the western boundary of the city. This great business artery now in the very heart of the city corresponds to Broadway in New York, or State street in Chicago, and yet there are thousands in the French quarter who have never crossed to the other side of this street. They have their own banks, cathedrals, theatres, hotels, stores and all the requisites of a great city, and will walk upon their own side of the street, but, have no desire to cross to the



H. M. LITTELL,  
President.

other or go beyond. And the strangest feature of this strange custom is that the people themselves seem unable to give any reason for this condition; their forefathers did not, they do not and their children implicitly and without question accept the self imposed restriction.

To cross Canal street to the east is an instant transition from America to France. The language of business is French, although many speak English, but the names of the streets and upon the signs and door plates are French, and the daily papers are published in that language as are the state and municipal laws. Among the unusual sights which attract the visitor may be mentioned the printed announcement in case of death. Formerly a servant delivered these notices, which were printed on cards and carried on a silver tray. Now they are published in circular form and quite an assortment meets the eye at every corner, tacked to telegraph and other poles. Another custom which would hardly be considered proper in some places, is that of attending early mass accom-

# SINDOS.

## Décéde

*Ce matin, Lundi, 27 Mars 1893,  
à l'âge de 45 ans.*

# Alvarez Sindos.

*Ses amis et connaissances, ainsi que ceux de ses frères, sont priés d'assister à ses funérailles qui auront lieu DEMAIN APRES-MIDI, (Mardi) à quatre heures.*

*Le convoi partira de sa dernière demeure, No. 166, rue Derbigny, entre Sainte-Anne et Dumaine.*

Nouvelle-Orléans, 27 Mars 1893.

**JOHN BONNOT, 45, Rue Sainte-Anne.**

panied by a huge market basket. To the REVIEW representative it was a highly amusing spectacle to witness the frantic struggle of hundreds of dames who with baskets and children thronged the Cathedral of St. Louis; and, after performing their devotions marched in a good sized army to the French market, where the chief dinner of the week is purchased. At this market, which includes several long buildings cut up into small booths, almost every imaginable thing pertaining to the culinary art, both cooked and uncooked, may be bought.



It is one of the sights of the city, opening at four o'clock in the morning, and presents a perfect babel of tongues as almost every known nationality is represented. Sunday is a gala day, and fortune tellers, side shows, and fakirs fill the street, with here and there a picturesque group of Indians selling herbs and charms. Fish and fowl are in great demand, the latter being sold alive and the good housewife returns home with the heavy basket on one arm and a squawking duck, goose or chicken hanging head down from the other hand. Passengers with such motley hand baggage are seen on every car in the French section on Sunday morning.

A few words historical will serve to bring us down to date. Louisiana was first visited in 1536 by Spaniards exploring the Mississippi river under Pamphilo de Narvaez. De Soto, another Spaniard, followed in 1539, after which no record is found of white men visiting the country until 1673, when Father Marquette navigated the great river below the mouth of the Arkansas. On April 9, 1682, La Salle erected a cross, fired a salute and took possession in the name of Louis XIV, of France, and named it after him, Louisiana. In 1699 a French colony of 300 men landed and established a fort at Biloxi, and in 1718 Bienville began clearing the woods on the narrow strip between the river and Lake Pontchartrain, and New Orleans had a beginning. Louisiana was ceded to Spain in 1769, with great military eclat, and strongly intrenched by the Spaniards. October 1, 1800, the territory was transferred back to France, and on April 30, 1803, ceded by that country to the United States for \$15,000,000. The official transfer was made on December 20, in the old city hall. The State of Louisiana was admitted to the Union in 1812. The important military events which occurred at New Orleans during the war of 1812 and during the Civil War add additional interest to a city full of historical scenes and landmarks.

Through all the vicissitudes of war and floods the city has marched steadily on, and now boasts a population of 300,000. Its importance as a great port and business center is well known throughout the world, of which it is the greatest cotton port. Two million bales are exported annually, and this business alone affords occupation to



CEMETERY SCENES.

150,000 of its population. The Cotton Exchange is an imposing building and cost \$380,000.

Prior to the war the sugar crop amounted to 200,000 tons annually. It is now less than half this amount. It



BANANNA WHARF.  
SUGAR EXCHANGE.

COTTON DOCK.  
SUGAR LANDING.

is, however, the greatest banana port in the world, 13 swift ocean steamers plying between New Orleans and Central America alone, in this rapidly increasing industry. Rice, farm products, fruits, and all the productions of thousands of square miles of the richest soil in the world, tributary to this city, combine to make it a great commercial center; and its manufactured products are constantly on the increase in number and output.

New Orleans is the only large city in the country which has no sewers. This is easily explained from the fact that city datum is several feet below the river, which is kept out by immense embankments. In all the gutters running water may be seen, which is led to a basin and pumped into a canal, which empties into the lake. A system of water works is in use for fire, flushing and sprinkling purposes, but rain water is used for drinking. The system of street cleaning is very complete and few cities enjoy as clean streets as are found here. Owing to the excessive amount of water in the soil basements are impracticable, and everything is above ground. Even in the cemeteries this law asserts itself, and all burials are above ground. These cemeteries are beautiful parks, and many of the tombs cost thousands. The poorer classes use what are called ovens, built along the cemetery wall, and in tiers of three or four, as shown in the illustration. Frequently fraternal or religious societies will unite and erect a marble building, resembling a chapel, with spaces for from 30 to 100 caskets. As the spaces are filled the aperture is covered and cemented and the desired inscription placed upon the cover.

Among the notable buildings may be mentioned the City Hall; the Parish Prison; St. Louis Cathedral; Masonic Temple; U. S. Mint; Howard Memorial Library; and the U. S. Custom House, covering an entire block, and containing the celebrated "Marble Hall," the roof of which is supported by solid columns of pure white marble, 41 feet high, each hewn from a single block costing \$8,000. The St. Charles Hotel resembles a state capitol in size and architecture, and before the war was the finest on the continent. The Hotel Royal is also historic as the former capitol building of the state. Among the most interesting relics are the Cabildo and Court buildings, facing Jackson Square, and erected by the Spaniards. Within the Cabildo all the transfers of the country from one sovereign to another were made. In 1826 it was elaborately fitted up by the city and tendered General La Fayette, who occupied it as his residence.

The ground floor is now used as a jail and police court, and the upper part by the Supreme Court of the state. The court buildings are separated from the Cabildo by the St. Louis Cathedral, and is historic as the residence of Pere Antoine, who came from Spain to establish the Inquisition in Louisiana. He failed in this, as the governor put him on board ship at midnight and banished him for several years.

Jackson Square, above mentioned, is a lovely little park, containing a very remarkable statue (see illustra-

tion) in bronze, costing \$30,000. The horse and rider weigh fifteen tons, and simply rest on the two hind feet of the horse, without a bolt or fastening of any kind, or other support. It has passed unmoved through hurricanes which leveled buildings. Numerous other statues pleasantly surprise the tourist; the Clay statue on Canal street; the Franklin; the Lee monument, 106 feet high; the Battle monument, the Confederate, and other monuments.

The unmistakable hospitality and cordial reception with which the stranger is everywhere greeted, is not only extremely delightful but sharply in contrast with the short cut methods of the North. A business man gladly goes out of his way to direct the stranger; and as business hours are from 9 to 3, with a liberal outing for lunch, the New Orleans merchant enjoys life to a degree entirely beyond the comprehension of a Yankee.

New Orleans is one of the best street car cities in the country, but until the Carrollton line was opened on the west side last year, there was a sad lack of suitable transportation. Canal street, from which all the lines in the city radiate, is one of the widest in the world, contains four tracks of street railway, and then has more room left than many cities with one track. This street will now be electrified, and not only Canal, but nearly all the other leading streets, and when this is accomplished there will come to this charming city a new life and impulse, which alone is lacking to give it that impetus and energy necessary to push it rapidly to the achievement of wonderful possibilities. This has been the universal history of electric traction, and it will not fail here. We believe the general introduction of electricity to be the most important and far reaching influence of any which has affected the social and business life of New Orleans during the past twenty years. This advance is already coming into existence, and a recital of what and how this will be accomplished is of unusual interest in the light of even the brief history outlined above.

The company which has undertaken this great work is the New Orleans Traction Company, operating the New Orleans City and Lake Railroad, and the Crescent City Railroad. At its head is one of the brightest managers in the fraternity, H. M. Littell, who combines in a large degree those elements of experience and progressive ideas which have made him so successful in the past, and which will forever link his name with the city's greatest improvement. Around him he has called a corps of able workers who will assist in the endless details of reconstruction. Mr. Littell is general manager of the Traction, and president of both the leased roads. A. H. Ford is secretary and treasurer; B. B. Gilman is superintendent,

#### INDEX TO ILLUSTRATIONS ON OPPOSITE PAGE.

1. Old Court Building.
2. Pickwick Club, Canal Street, (recently burned).
3. Cotton Exchange Building.
4. St. Louis Cathedral, Jackson Square and Monument.
5. U. S. Custom House.
6. Street Railway Pleasure Resort, Lake Ponchartrain.
7. City Hall.
8. St. Charles Hotel.
9. Canal Street and Clay Statue.



VIEWS OF THE  
CRESCENT CITY



G. A. Hopkins is chief engineer, and B. Willard, chief electrician.

In the first place the city has many natural advantages to encourage the introduction of electric traction, among which are the absence of grades and those difficulties which attend operation in northern cities during winter months. Naturally there are some novel features of construction, which, with a statement of other plans adopted will be found extremely interesting.

There will be 120 miles of trolley construction, consisting mostly of side-pole suspension, supplemented by 125 miles of feed wires, some of which will be carried on span wire poles and some of which will be carried on separate poles erected for that purpose alone. The pole specifications are for octagonal sawed poles, 30 feet long, 12-inch butt and 7-inch top, made of Louisiana pine, as

the ground. The three methods employed in setting poles are clearly shown in Figures 1, 2 and 3, and will probably need no further explanation. However, attention may be called to Figure 3, which represents a method employed where poles are set near a deep gutter, or on the edge of an embankment where bonding in front would be of no purpose.

Each of the several lines in the city will have their respective feeder systems and be absolutely independent of one another.

The trolley lines will be divided into sections of approximately 4,000 feet each. (See Figure 4.) Each section being fed by an independent feeder, to which is attached a 500-ampere switch, fuse and lightning arrester, contained in a suitable iron box numbered to correspond with the respective sections. (See Figure 5.) In order

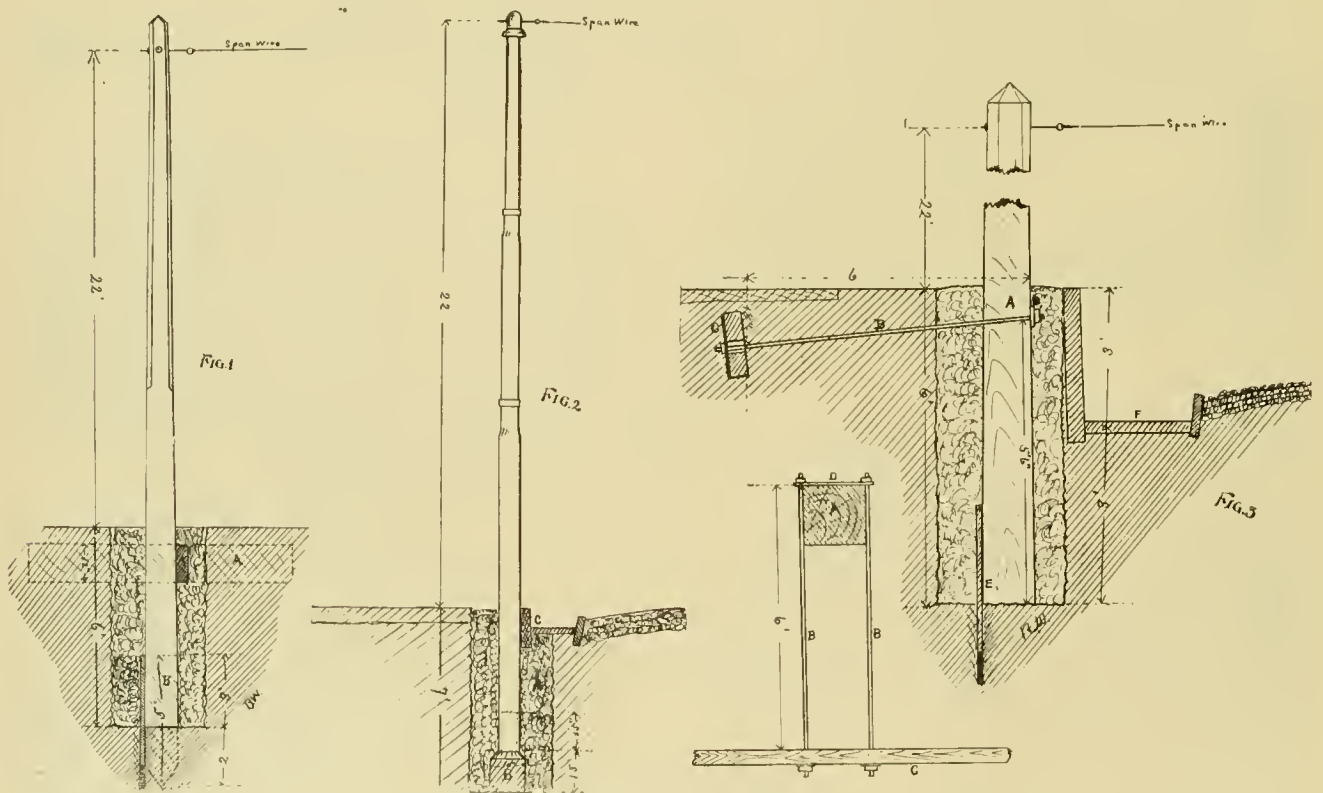

approved by the city government. In addition to this is about four miles of iron pole construction, part of which is located on lower Canal street, and representing construction which was commenced about a year ago. The iron poles used on this construction are what are known as pipe poles, 28 feet long, made of 6-5 and 4-inch extra heavy pipe, with shrunk joints. Additional specifications are made for special strain poles, which are of the same character, but with increased dimensions. The wooden strain poles are 33 feet long, with 14-inch butt and 9-inch top; the iron strain poles are 30 feet long, made of 5-6 and 7-inch extra heavy pipe. The soft, wet character of the soil and other objectionable features make it necessary to use additional precautions in setting poles sufficiently solid to withstand the strains without moving in

to maintain the value of the trolley wire in the distribution of the current, it has been customary to avoid the use of sectional insulators and make the lines continuous. This is detrimental, owing to the occurrence of breaks, which necessarily effect the entire system. To maintain all of the properties of a continuous and sectional trolley line, a fuse has been designed to bridge each sectional insulator, which not only serves to maintain the line continuous, but acts as an automatic device to disconnect the section in the event of a short circuit. In laying out the feed wire construction, it has been the aim to make the work appear neat and substantial, at the same time keeping within the bounds of reasonable cost. Figure 4 will give an idea of the general methods of distribution. The small feed wires 000, and 0000, are carried on poles

which support the trolley, and all are carried back to one centre of distribution, "A" to which connect heavy cable feeders of 500,000 circular mils capacity, connected direct to the switch board at the power house. In this way the necessity is avoided of carrying each of the smaller feeders back to the power station which would make the construction appear unsightly and costly. In estimating the necessary feed wire, it is only necessary to determine the required amount of current needed at each of the points marked "B" Figure 4, and with the desired loss, figure back to section marked "A." From section "A" must be figured the entire current for the whole system at a desirable loss in potential to the power station.

Figure 6 will give an idea of the method used in connecting the large cables with the smaller feed wires at the section marked "A" in Figure 4. Instead of ending these wires on the ordinary cross arm, a special frame is made of angle iron and firmly bolted to the top of the pole. Each feed wire is then ended and anchored to this frame by means of an eyebolt, to which is attached a strain insulator. For connecting the several wires together a solid conductor is run near the outside edge and a little above the iron frame, and supported by top groove insulators, to which is attached the several short cable connections which are fastened to the several feed wires. Should it be necessary to disconnect any one wire, it can be done by disconnecting the short cable connection and throwing out the switch corresponding to that section. The joints of the short cables are not soldered but simply connected by means of a "tee" provided with set screws. All poles used for carrying feeder wires are double cross armed and have two insulators for the attachment of each wire. Heavy top groove glass insulators are used for carrying the heavy cable construction, and no suspension cables will be used.

The rail bonding consists of No. 6 copper bonds fastened to the rails by  $\frac{9}{16}$  channel pins with cross bonds 120 feet apart. Where it will be necessary for the rails to carry a large amount of current to supplement other lines the bonding will be increased proportionately and several bonds used to each joint. No dependence is placed on the use of ground plates as an auxiliary to the rail return circuit, although some ground plates will be used for connection to the lightning arresters and to neutralize the potential between the earth and rails. The rail construction consists of 100 pound girder and 60 pound T, which affords ample cross section for the carrying of heavy currents with proper bonding and absence of supplementary wires.

The car house is located at the corner of Arrabella and Magazine streets, and its dimensions are 240 by 260 feet with a maximum height of 65 feet at the center.

A transfer table is located in the center of the house with a capacity to accommodate a 30 foot car. It will be operated by an electric motor. There will be 20 storage tracks aggregating nearly a mile of track construction, part of which will be over pit room to accommodate 15 cars. The pits will be made of seasoned pitch pine treated in hot carbolineum "to resist the dampness and prevent decay." The pits will be four feet deep from the top of the rail and sheeted up with 2-inch matched flooring with white lead between each joint. When the pit is in place it will be two feet below the water level of the

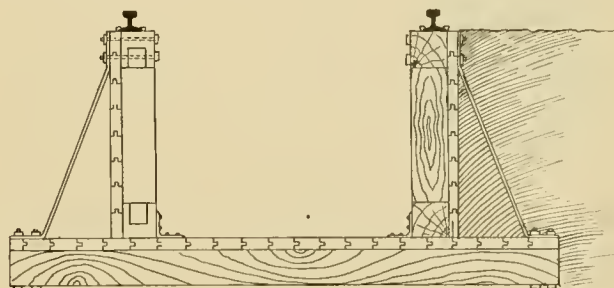

CROSS SECTION OF PIT.

surrounding country, and to keep it from rising or floating out, wings are constructed at the bottom which are 22 inches wider than the pit on either side. The pressure of the dirt on these wings serves to anchor it in place. The insurance men ought not to worry about the water supply in these pits. A repair shop will occupy one corner of the car house, which will be provided with pit room for two cars and the necessary tools for light repairs.

The car equipment will consist of G. E. 800 motors and type "K" controllers. There will be two motors to each car. Eight wheel cars will be employed for part of the service, the length of bodies of which will be 20 feet. There will also be 50 open and closed cars with bodies 16 and 20 feet respectively, equipped with W. P. 50 motors mounted on McGuire Columbian trucks.

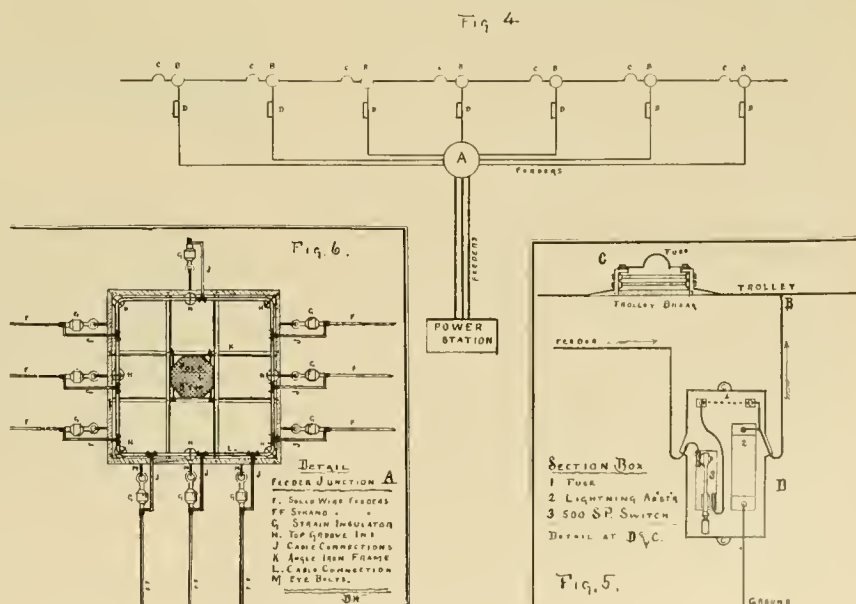

Fig 4

Fig. 6.

SECTION BOX

FIG. 5.

- DETAIL  
 FEEDER JUNCTION A  
 F. SOLID WIRE FEEDERS  
 FF. SHAND -  
 G. STRAIN INSULATOR  
 H. TOP GROOVE INS. -  
 J. CABLE CONNECTIONS  
 K. ANGLE IRON FRAME  
 L. CABLE CONNECTION  
 M. EYE BOLTS.

- 1 FUSE  
 2 LIGHTNING ARRESTER  
 3 500 S.P. SWITCH  
 DETAIL AT D.V.C.

The power to be used in operating the road will be furnished by the Louisiana Light & Power Company, which intends installing 2 M. P. 200 kilowatt and 2 M. P. 500 kilowatt generators for present purposes. The charges are to be made to the railway company on a basis of a car mile rate.

After reading the account of the extensive plans it will be fitting to know something of B. Willard, the constructing electrical engineer, who made them and who deserves great credit for the way he has overcome the difficulties of construction in a city as far under water as is New Orleans. In many of the electrical features it will be seen that Mr. Willard has profited to the fullest extent possible by past experience in electric railways.



B. WILLARD.

Mr. Willard first saw the light at Utica, N. Y., in 1863. After finishing his education he went into the employ of an electrical appliance manufacturing concern for three years. Desiring to gain a general knowledge of machine work he served a year in a machine shop at Fitchburg, Mass. Coming to Chicago in 1883 he became a partner to a builder, remaining two years. In 1885 he went to Lynn to take up his favorite line of work with the Thomson-Houston Company, and soon was sent out over the country installing electric light plants. His first railway construction was done in 1888 on the Omaha & Council Bluffs Railway. Since then he has continued on railway work in the employ of this company, until January 1, 1894, when he became constructing electrical engineer for the New Orleans Traction Company.

THE ALTOONA MANUFACTURING COMPANY, of Altoona, has had recent orders that show continued popularity of the M. A. Green engine and the reawakening of trade; besides a multitude of electric light power equipments and general business there have been shipped two 175 horse power special railway engines with boilers and steam plant complete, to the Lynchburg & Rivermont Street Railway Company, of Lynchburg, Va., which plant is now in process of erection: two 150 horse power engines with steam plant complete for the Ringing Rocks Electric Railway Company, at Pottstown, Pa. These two latter will be of special interest to the electrical fraternity, owing to the fact that they are to be direct connected to two power generators of a design imported from Germany, and are the first engines that have been direct connected to this make of generators in the United States, for electric railway service.

GIDEON KELLOGG, sales agent for the Charles Munson Belting Company, Chicago, has meet with great success.

## FRANK X. CICOTT.

The recent reclaiming of Frank X. Cicott to the American street railway field is the occasion of great rejoicing among his many friends.



FRANK X. CICOTT.

Mr Cicott has engaged himself as manager of the railway department of the extensive corporation of the Pettingill-Andrews Company, of Boston, after several years in Europe as managing director of the Tramway World of London. Mr. Cicott since his young manhood in Detroit, has been intimately connected with almost every phase of street railway work. For several years being agent for Holmes, Booth & Haydens on the Pacific coast, and doing a large general business—both there, and with the Electrical Merchandise Company, Chicago.

Known intimately to the tramway men of Europe and America with political honors and military standing, a newspaper man of experience, and a business man of consummate ability, the Pettingill-Andrews Company have found in Mr. Cicott a rare example of the enterprising, cultured and traveled manager, cosmopolitan in experience, and thoroughly American in the quality called "push."

SPECIAL evangelical services, for the benefit of the Consolidated Traction Company's employes, are held by the Traction Soul Saving Association, of Jersey City, N. J. A small organ is brought into the conductors' waiting room, and the service is mainly musical. Bad boys in the neighborhood have tried to break up the meeting, so far unsuccessfully.

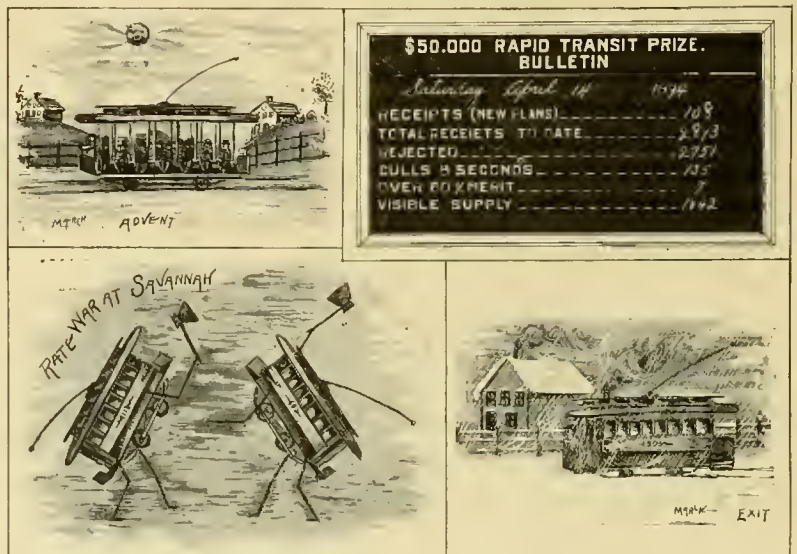

PICTORIAL EVENTS OF THE MONTH.

ERASTUS WIMAN has resigned his presidency of the Staten Island Rapid Transit Company, New York.

**HALF FARES.**

Interesting Facts from All Parts of the Country Boiled Down for Busy Readers.

M. JABLOCHKOFF, the famous Russian inventor of the "electric candle," is dead.

THE Moline, Ill., Central Street Railway Company will lease Prospect Park and make a summer resort.

THE North Chicago Street Railroad Company declared its regular quarterly dividend of 3 per cent., payable April 17.

THE Olean, N. Y., street railway company has reconstructed a street car into a dump gondola to help the construction gang.

THE Third Avenue Railroad Company, of New York, has instituted a signal system similar to the one now in use on the West Chicago cable.

THE Covington (Ky.) Street Railway Company will probably run a funeral train to the St. John and Highland cemetery when the Lexington pike extension is made.

A NEW YORK man was thrown off a street car accidentally and lost eight teeth. He has just received \$1,000 damages or \$125 a tooth. This is expensive dentistry.

JOHN CRILLY, 123 California street, San Francisco, is handling quite a number of railway specialties, including the Pacific Coast Agency for the Peckham Truck and Wheel Company.

THE Norwalk & South Norwalk, Conn., Tramways have secured extensive rights to extend, and will build a line to Bell Island and Roton Point. A summer resort business will be done.

A NEW "model" town is to be built near Allentown, Pa., on the line of the electric railway. It will be called Manhattan, and is to be built on a copyrighted scheme of Chas. F. Molly, of Bethlehem.

MAYOR HOPKINS, of Chicago, has decided on a vigorous prosecution of the North Chicago Street Railway Company for rent claimed to be due for the use of the La Salle street tunnel to the amount of \$29,311.

AN electrical phaeton at Rheims, France, has been recently attracting attention on the streets of that city. Nine miles an hour is attained on level pavement. The vehicle weighs 2,970 pounds and carries 6 passengers.

CORNELIUS DESMOND, a Boston councilman, has absconded with \$1,000. For eight years he has been a trusted employe of the West End Street Railway Company. It seems that aldermanic associations were death to his morals.

THE new incline machinery at Duluth, Minn., has been satisfactorily tested. The new cable has a factor of safety of eleven and the hoisting apparatus a speed of 1,200 feet a minute. E. P. Allis put in the machinery.

THE Metropolitan L of Chicago will open for traffic in about ninety days. No great delay is anticipated because of the new bridge. The matter of electrical equipment is still in statu quo. Only men will be employed in the ticket selling service.

LEAVENWORTH, KAN., will have an electric fountain at its soldiers' home. The Street Railway Company, of which L. M. Erb is superintendent, will pay half the cost and the citizens the other. It will cost \$50,000. A funeral car service will also be instituted.

ALAMANDO B. RUSS is the name of the inventor of a Californian safety fender. This fender picks up the person in danger, brakes the car, and throws the trolley off the wire all at once and automatically. Alamando should invent a car starter attachment to accompany his fender.

THE Buffalo, N. Y., Express, of recent date, gives a fine map of the city, and remarks in its real estate column, the large developments consequent upon the electrifying and extending of the Buffalo Street Railway Company under the judicious management of H. H. Littell.

FOUR men who attempted to wreck and rob a West Chicago street car were recently arrested. Three escaped. The car was derailed, and during the excitement revolvers were presented by the bandits and wholesale robbery begun, when the police appeared, with the above result.

A DRUNKEN MAN recently mounted a Wichita, Kan., street car, and mistaking the fare box for a nickel-in-the-slot machine invested a quarter in vain attempts to get something out of it. The driver finally noticed him, and gave him enough good advice to last two weeks, but the money was gone beyond recall.

THE House of Representatives at Washington has directed the Metropolitan Street Railway Company to substitute the underground conduit electric for horsepower now in use. Albert Wheeler, of the Love system, will make an attempt to introduce his plan on the Chicago City Railway. The U street line of the Love conduit is thus congressionally approved.

HOTEL ARAGON, of Atlanta, the headquarters of the coming convention is second to none in the country in the completeness of its appointments, and attending delegates will find there every convenience, comfort and luxury, that can be found in any hotel in any great city of the country. It is the endeavor to make it the finest hotel in the south. Its opening ushered in a new life in this enterprising southern city and high carnival reigned supreme for a week.

THE employes of the Johnstown Passenger Railway surprised Vice-President J. B. Hoefgen with a gold-headed cane. The presentation speech was made by D. B. Mudgett, the oldest employe of the company.

A BILL compelling the use of vestibules for the protection of motormen, died a natural death in the Maryland legislature. Some day Florida's legislators will want a similar bill passed to protect sub-tropical motormen from sunstroke!

THE Traction Company, Reading, Pa., has a novel method of choosing laborers for its extension building. Two cart loads of picks were driven to the point of beginning and every man who got a pick got a job. Three hundred participated in the scramble, and 100 triumphantly bore away a pick.

EX-PRESIDENT BENJAMIN ORNE, of the Naumkeag Street Railway Company, of Salem, Mass., is suing for salary and expenses as chief executive of the line named. Among his expenses are the following items: Pew rent in a Salem church, a grocery bill and house rent. Mr. Orne's monumental nerve should get him a seat in the city council.

THE Buffalo & Williamsville Electric Railway carried 191,000 passengers last year, the first of its existence. A new summer resort will be constructed at Williamsville and a lake of 100 acres formed by damming a stream and flooding the lowland. A spouting mineral water stream and a white sulphur spring are among the attractions of the place.

IN a letter to the REVIEW dated March 20, W. E. Garstin, under secretary of the public works department of Cairo, Egypt, informs us that none of the offers for the Cairo Tramway concession were accepted, none being in accordance with the specifications published. The last date for bids is now August 1, and the American consul is F. C. Penfield, Cairo, Egypt.

A TROLLEY CAR jumped the track in St. Louis not long ago, and a passing farmer taking a crowbar from his wagon got out to help the tugging crew. The trolley wheel had not left the wire, and just as Mr. Farmer had made a good connection with his iron bar the motor man turned on the current. Like a flash the car took the track, the crowd yelled and the farmer sat down hard with a lot of electricity in him. He arose, cursed volubly and got back on his wagon.

THE Market Street Consolidated Street Railway Company, of San Francisco, has on hand a project for the building of an immense power house at the corner of Channel and Bryant streets. It is planned to have room for increased power as other lines are electrified. The first capacity will be 1,800-horse-power, and the possible amount 7,000. The Howard street line, the South San Francisco, and the Third, Fourth and Fifth street lines will be operated electrically before many months.

## PERSONALS.

W. H. WOOD, Media, Pa., the well known hydraulic engineer was a visitor at the REVIEW office during the month.

W. F. FURBECK, vice president of the North Side lines in this city, is spending several weeks in California, accompanied by his family.

GEO. O. MANCHESTER, formerly of the A. T. & S. F. R. R. has been elected vice president and manager of the Sargent Company, Chicago.

J. WM. HELM, secretary and treasurer of the North Chicago Street Railroad, has just recovered from an attack of grip, the result of overwork.

JOHN W. MARTIN, who at the expense of an arm escaped instant death under the wheels of a locomotive, is recovering as rapidly as could be expected.

CAPT. ROBERT McCULLOCH, general manager of all the lines in St. Louis owned by the Chicago syndicate, was a most welcome caller at the REVIEW office this month.

F. S. PIERSON, who was so well known as electrician of the West End road, Boston, has succeeded Major McNulty as chief engineer of the Broadway cable line in New York.

DAVID J. DUNCAN, formerly of the Hornellsville, N. Y., electric railway, has accepted the superintendency of the Carbondale (Pa.) Traction Company, which is about to build 32 miles of line.

C. S. VAN NUIS, constructing electrical engineer at 136 Liberty Street, reports that business in his line has opened much earlier than usual this year, and that he has a large amount of work in hand and that the outlook is very encouraging.

E. M. BENTLEY & G. R. BLODGETT, for some years patent attorneys in Boston, have dissolved partnership. Mr. Bentley remains in Boston, and Mr. Blodgett goes to Schenectady, N. Y., in charge of the patent department of the General Electric.

F. A. HOOVER, manager of the New Castle Car Company is a man of many talents. He is a select councilman of New Castle, Pa., and was recently admitted to the bar. He is prominent in more than one enterprise in his neighborhood.

EBEN S. ALLEN, formerly president of the Grand and Forty-second Street Railway Company, of New York City, has been released from his imprisonment at Sing-Sing, for a fraudulent issue of stock. He was sentenced for 14 years but was commuted at 4½ years by Governor Flower.



**THE THREE-WIRE TROLLEY SYSTEM  
AT PORTLAND, ORE.**

By A. C. Balch.

The street railway systems of Portland, Oregon, receive the greater part of their power from the Union Power Company. In order to obtain cheap fuel, the station of the Union Power Company was placed near a large saw mill, and the refuse from this mill used. The distance between the station and the centers of the systems supplied with power is about three miles and, at times, the load upon the station approximates 1,500 horse-power. Early in the course of estimating the probable cost of installing the electric systems, it became apparent that if the station were to be placed near the saw mill, to take advantage of the cheap fuel, the extra cost for feeders would be considerable. To reduce this cost it was

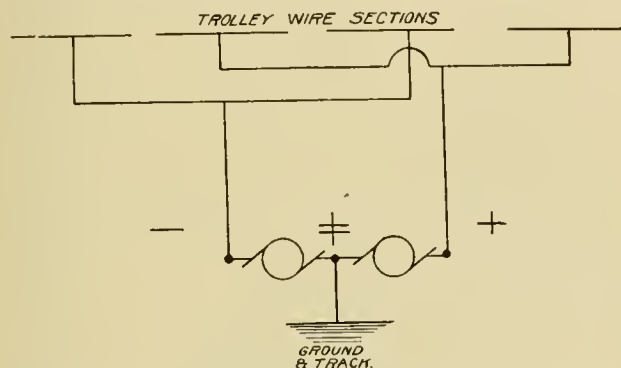

decided to adopt the three-wire system of distribution. This had been shown to be a success in lighting work, but had not been previously tried in the actual every-day operation of street railways, at least so far as was known to the writer, who was the engineer in charge of the installation of the station. There is now no doubt of its entire success, as the plant has been in operation on the three-wire plan more than two years without any delay whatever, chargeable directly or indirectly to its use. Further, a direct illustration of one of its advantages was had as follows: Part of the system supplied with power was in readiness and in use some months before the whole system was completed. This section had eleven double reduction Sprague motor equipments in operation and the feeders supplying the power were arranged on the ordinary plan for railway operation, but were calculated to run seventeen cars after the whole system should be completed. As the feeders were figured on the three-wire basis, it was found necessary to run the voltage at the generators at 600 volts, and, even then, at times, the voltage on the line fell to 350 volts. When the whole system was put in operation no change was made in the number or arrangement of the feeders for this section, the six cars were added, the voltage at the generators was lowered to 550, and yet the voltage at the cars never fell below 450 volts.

At the Washington convention of the National Electric Light Association, J. H. Vail read a paper advocating a complete metallic circuit for street railways. His

plan involves the use of track feeders. The three-wire plan accomplishes his results with a saving in wire of over fifty per cent.

Several companies operating water works in cities where electric traction is employed have complained bitterly of the electrolytic action caused by stray currents, or the use of the water pipes as an additional ground. In answer to a query from Omaha water works officials, as to the methods employed in Portland to obviate the pitting caused by electric action, the superintendent of the Portland company replied that no such trouble had occurred. The reason for this is, that the return circuit is all copper, and there is a pressure exerted to make the current take this path in preference to the water pipes.

The wiring of the car, the overhead construction, the track, in short all the installation outside of the power house, is done according to ordinary two-wire usage. Each feeder, or set of feeders, supplies a section. This section is insulated from the adjoining sections. The track is the neutral. Alternate sections are of opposite polarity and there is a difference of potential of 1,100 volts between the sections of trolley wire. The station installation is according to ordinary three-wire lighting usage, except that no compensating or potential regulating devices are used on the feeders.

The operation of the dynamos does not differ from the operation of the same machines in ordinary railway usage.

Among the advantages over the present two-wire usage are fifty to sixty per cent saving in copper for installation, no electrolytic action on gas or water pipes, and a complete metallic circuit. To offset these manifest advantages, the writer has yet to discover a single disadvantage, although the system has had a two years' trial in all kinds of weather and under all the conditions met in street railway work.

In conclusion, the three-wire system seems peculiarly adaptable to installations in cities like Philadelphia, where, in many instances, single tracks are laid in parallel streets; to double track roads, using a pole between the tracks to support the trolley wires and with slight modifications to long distance suburban lines.

**ANOTHER ST. LOUIS CAR BARN FIRE.**

Shortly before midnight March 20, a bolt of lightning struck the car barn of the Missouri Street Railway Company, on Cardinell street, St. Louis, setting the structure on fire instantly. Before an engine could be summoned the fire had taken the entire roof. There were eleven motor and twenty-eight trail cars in the building, besides sand and salt cars. All were consumed. The barn faced 210 feet on Laclede avenue and 110 feet on Cardinell. A barn on the same spot was burned two years ago in the same manner. The loss was \$80,000, fully insured.

GROUND has been broken for the new car barns of the Cincinnati Consolidated. A passenger depot will also be built.

## ON ECHO MOUNTAIN, CALIFORNIA.

The Mount Lowe Electric Railway, described last year in the REVIEW, has on hand a plan to actuate the cable incline from a separate electric plant. A fall of 1,400 feet in 3,000 through a heavy pipe will furnish the power for a Pelton water wheel, from which an independent dynamo will be run for the cable incline. Heretofore the power was transmitted from Altadena to the power house on Echo Mountain. On account of the death of Electrician A. W. Decker, the plan to use storage batteries has been abandoned.

The success of the road has been marvellous. Californian tourists, since January 1, traveled to Echo Mountain to the number of 150 to 350 a day. The necessity

## PLEASURE RESORTS AND CREATED TRAVEL.

The Toronto Scarboro Electric Railway.—A Pleasure Resort Route.

## PART V.

Toronto is unusually blessed in the way of fine natural parks near at hand, but it took the citizens as a whole a long time to find this out. Among the first to discover and act upon it were the promoters of the Toronto Scarboro Electric Railway. When completed, this system will comprise about fifteen miles of suburban belt line connecting the towns located in the beautiful country east of Toronto, with that city, developing a suburban country residence district as well as a pleasure resort business. It will carry freight and express.

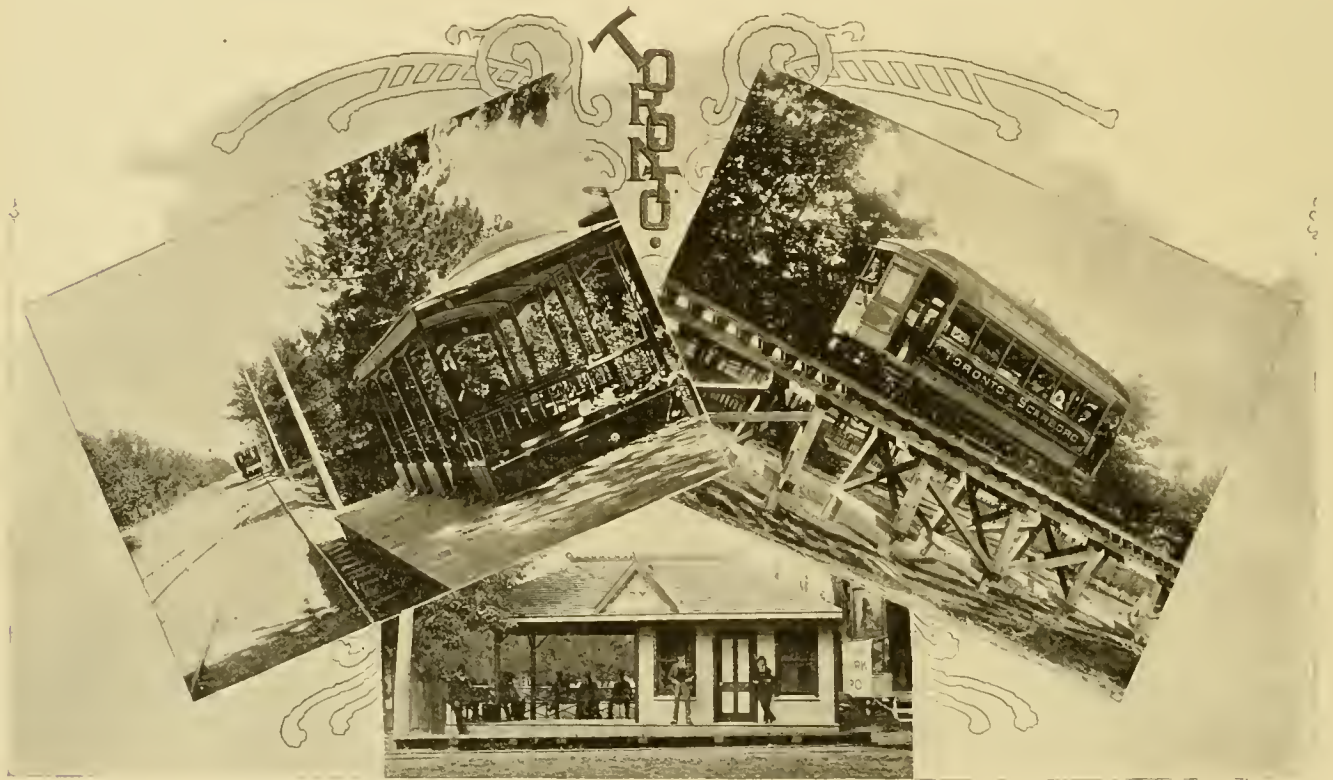

of an extension is conceded by the twenty or thirty tourists who daily go via burro further on up Mt. Lowe.

The very latest feature is the publication of a daily and weekly illustrated paper on the mountain, and named the Mt. Lowe Echo. G. Wharton James is the editor, and his publication is the finest of its kind extant.

THE all powerful British Board of Trade has just issued its regulations relative to the protection of gas and water pipes from electrolysis. One of the conductors between the generators and the motors must be completely insulated from the earth. The return under certain conditions need not be. All feeders must be so insulated that leakage may not exceed 1-1,000 amperes per mile. If the leakage exceed  $\frac{1}{2}$  ampere per mile, it must be stopped in 24 hours or the cars cease.

A trip over the road now laid is one of the most pleasant outings available to the Toronto citizen. Taking a King street car of the Toronto Railway Company, he is soon at Woodbine station, the city terminus of the Toronto & Scarboro. It is a neat little depot on the cottage style. Half is open and half closed. Entering an elegantly fitted up car on the new line, he glides away through pleasant hamlets until the car begins to climb a steep grade and the unfolding panorama makes the passenger aware that he is on a "scenic" route. Lake Erie spreads itself out like a boundless ocean, with Toronto on its shores to the right. It is not necessary to enlarge on the grandeur and beauty of the scenery, as our engraving tells this better than words. At the present terminus of the road at Blantyre avenue, an open car body has been placed for a waiting room. From here it is but a few steps to Victoria park. It is here that the palisades known

as Scarboro Heights begin. They are rivalled only by palisades of the Hudson. With its comfortable summer climate it will be strange if Toronto, through the medium of the Toronto & Scarboro Electric Railway, Light and Power Company, does not here establish a summer resort of national reputation. It is only a little over a year since the company was organized and the length of the present route speaks volumes for the energy of the management. The directors are all prominent business men of Toronto. The management is composed of

royalties on cable machinery manufactured by the company under patents owned by Mr. Walker.

He has now granted the Pennsylvania Iron Works Company, of Philadelphia, rights to manufacture under his cable patents in the Atlantic states, while the middle, and perhaps the Pacific states will be handled by Fraser & Chalmers of Chicago; while Fraser & Chalmers, Limited, of London, will manufacture under the same patents for Great Britain, all the British Colonies and possessions. Notice was served the Walker Company on February 12th to refrain from further use of the patents in question, which include differential drums, struts, U-frames, cable friction clutches, operating mechanism for same, etc. The engineering fraternity of Chicago will welcome his presence here as a valued acquisition to its numbers, as he is a member of the American Society of Mechanical Engineers, the New York Engineers Club, the Civil Engineers Club of Cleveland, and other engineering societies.



FROM THE HEIGHTS.

D. G. Stephenson, president; J. J. Foy, vice-president; A. W. Dingman, secretary and general manager; John Galt, consulting engineer.

The country traversed is such as to make the growth of traffic almost certain. As a place for summer country residences the territory northeast of Toronto will be unequalled. This traffic in addition to that of temporary park visitors from Toronto ought to make the road a paying investment.

**JOHN WALKER COMES TO CHICAGO.**

Chicago secures a well-known engineer, inventor and manufacturer, in the person of John Walker, founder and until February 12, last, vice president and general manager of the Walker Manufacturing Company, Cleve-

A PLAYFUL youth, at Logansport, Ind., jumped into the exhaust well of the street railway power plant. He sank into the boiling bath up to his shoulders. He was eighteen years of age and knows better now. He will recover.

SINCE the demise of the New York Electrical Club, no one has attempted to reorganize it. The Hotel Imperial, up town, Ferdinand's in Twenty-third street, and Nelson's cafe at lunch time are the principal places of rendezvous.

**THE NEW METROPOLITAN "L" BRIDGE.**

The accepted plans of the Metropolitan West Side Elevated Railway Company, for a bridge across the Chicago river, between Van Buren and Jackson streets, are herewith illustrated.

As may be seen from the engraving, the plan is for a vertical lift of the two sections. Counterbalancing weights aid in the operation, so that a 25-horse-power motor is all that is required for opening and closing the bridge.

The clear space between the piers for the passage of vessels is 108 feet, while from city datum to the top of the

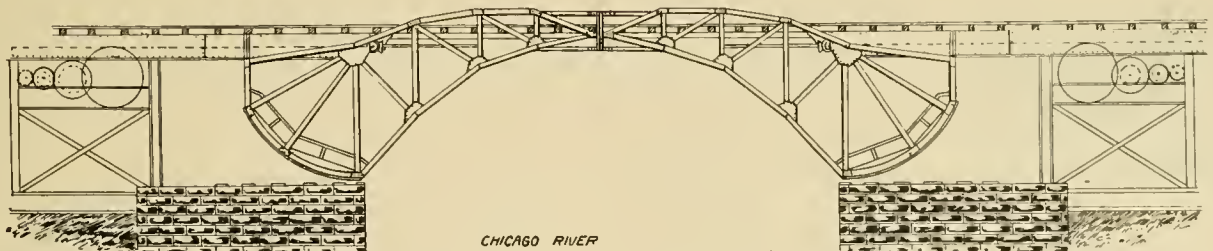

and. Mr. Walker becomes general manager of the extensive interests of the Fraser & Chalmers Company, Chicago and London, and entered on his new duties March 15th. His separation from the Walker company grew out of differences respecting the payment of

tracks is 37 feet 9 inches. Four tracks will cross the top of the structure, and its cost will be \$150,000.

In most particulars the bridge is on the same plan as the one now under construction by the city at Van Buren street.

### SPECIAL FORM BRICK FOR T RAILS.

That the T rail has come and come to stay there seems to be no question, as the number of companies successfully using it in paved streets has fully demonstrated. The only question is as to the best method to use. D. F. Wheelock, chief engineer of the Franklin Electric Street Railway, Warren, Pa., writes as follows regarding the method used on that road: "After a very careful investigation of the subject of using a T rail for street car lines I have become satisfied that it is the best and that it is a question of only a little time when it will be generally used. We will use it on our entire line, and

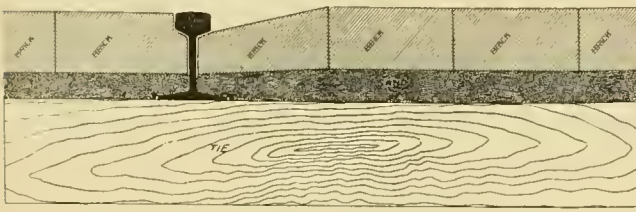

where there is a brick pavement will use a form of brick that is represented in the accompanying sketch, which has very many advantages not possessed by a girder rail, and which will be apparent from a careful study of the plan. I may mention one; that the pavement is used nearly as evenly for travel as where no street car track is laid, as the wheels of a vehicle are enabled to pass over the line at any point without the usual jar and slewing which is always so unpleasant. I might mention many others."

The regular bricks are  $4\frac{1}{2}$  inches high and  $8\frac{1}{2}$  long. The special bricks are  $2\frac{3}{4}$  inches high on the end against the rail. The rail is  $5\frac{3}{4}$  inches high.

### OSAGE ORANGE FILLERS FOR PAVING.

By C. L. Wakefield, Queen City Railway, Dallas, Texas.

I have noticed the discussions with regard to the best mode of using "T" rail, so as to practically do the same duty as a girder. In the construction of our road we used a bois d'arc strip, commonly known as Osage orange, a wood that is practically indestructible and as hard as lignum-vitae; it has been known to last as posts in the ground as long as thirty-five years. We used a bois d'arc strip two inches square laid between the



block and the "T" rail, which we find gives entire satisfaction. We have been running now since the first of August, and there has not been any damage to wheels of vehicles passing along or crossing our tracks. These strips cost  $2\frac{1}{4}$  cents per running foot, or \$237.65 per mile of track.

### THE WARD ELECTRIC 'BUS IN LONDON.

Ever since 1882, Radcliffe Ward, a well known London electrician, has been conducting experiments in storage battery traction with greater or less success. His principal aim has been to afford the 'bus traveling public of the metropolis an electrically propelled vehicle. His first storage battery 'bus was publicly tried in 1888 with results that encouraged Mr. Ward to carry out details until the present

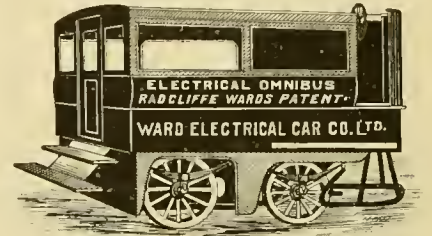

time, at last securing what he regards as a practical and commercially successful, self-contained electrical road wagon. Some further investigations of rubber pneumatic tires will be made. The 'bus of the 1894 pattern is shown in our engraving, for which we are indebted to Industries & Iron, London.

### GENERAL ELECTRIC NUT LOCK.

The G. E. 800 motors are now fitted with a nut lock that precludes all possibility of losing a nut. It is simply a cap arranged to fit over the hexagonal nuts and held on by a split pin put through the end of the bolt. The

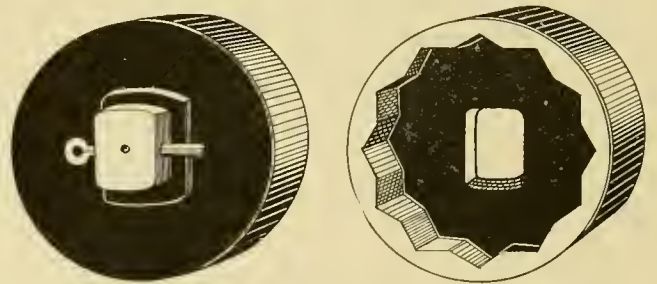

cap has twelve corners instead of six, so that there are twelve possible adjustments to one turn of the nut instead of six as there would be if the cap were made with six corners.

WILLIAM H. GRAHAM, secretary of the Pleasant Valley Traction Company, Pittsburg, is in California for a vacation. Before he went, the Sunday school of which he is superintendent presented a gold-headed cane to him.

THE plan of the Oakland Consolidated Street Railway Company, of giving coupons to each passenger and attaching prizes to the largest number of coupons returned to the street railway office, has been eminently satisfactory to the company and to the patrons. The usual plan is a pooling of coupons and their presentation to some charitable object. The city papers take interest in the results and the public generally applauds the charity.

## A CAR SHOP FIRE AT CLEVELAND.

The Cleveland, O., Electric Railway Company's shops on Pearl street, near Clark avenue, were totally destroyed by fire, March 21. The building was a one-story frame, within which were two cars, seven motors, lathes, drills, two engines of 20 and 60 horse-power, respectively, with all the tools of forty mechanics. The total loss was \$35,000, insured. Incendiarism is strongly suspected.

## THE FALCON FENDER.

The "Falcon" fender, which is the invention of E. M. Thompson, of Indianapolis, is the result of experiments with numerous devices on the Citizens Street Railway at that place. The fender is made of gas pipe and sheet steel. The motorman, by pulling a rope, throws the fender back under the car, and by pulling another, throws it forward for business. It is carried forward all the time while on the street. When in collision with any person

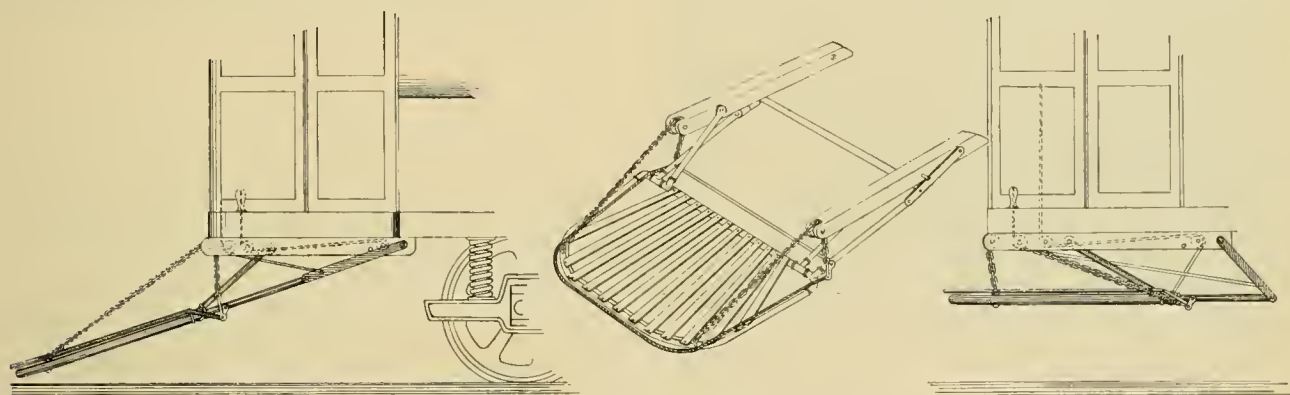

THE FALCON FENDER.

the first thing to strike is the touch rail, which projects a little forward from the fender proper, and is connected with the suspension mechanism, so that it drops the fender close to the ground when struck. Nothing but collision with the touch rail can lower the fender. Although ordinarily the fender will slide along the pavement without catching, provision is made so that if it should catch by some unforeseen accident it will turn back under the car and not get under the wheels. The fender has much to commend it and has received endorsement from several managers who have witnessed its operation. It has made a desirable record on Indianapolis cars, where the fender has been running experimentally several months, and has in a number of instances saved intoxicated persons and others who but for it would in all probability have been killed. When a car goes into the barn the fender is thrown back under the platform entirely out of the way. Mr. Thompson is organizing a company and will manufacture.

The west side lines of the Big Consolidated at Cleveland were recently blocked by the grounding of the cable, which runs under the river, to supply those lines.

## A COMMON FALLACY.

It seems to be a very common belief among electric railway men, that on the ordinary electric road as it is run at present, a heavy drop of potential between the power house and points on the line means an increased fuel bill. This would be true were it not that the potential is commonly kept constant at the power house, and loss of voltage shows itself in decreased speed of cars, and not in an increased fuel consumption. If the voltage at the cars was kept at a fixed point, and the station voltage raised to make up for any loss in the lines, the fuel would be increased, but with the prevalent practice of keeping the station voltage at approximately the same point, it is the speed and not the fireman that suffers. That this must be the case is evident on a moment's thought, yet many old hands at the business will say when first asked in regard to the matter, that reducing the voltage increases the current. It is of course true that a motor will be more efficient at the voltage and speed for which it is built than at a very much lower one. This factor in

the problem is so small, however, as to make almost no difference under any conditions of actual railway work. The fallacy has probably arisen from the fact that roads having a large line and return drop, are so poorly managed in other respects, that the fuel bill is high, and hence the drop was assigned as the cause of the heavy fuel consumption. A road having a heavy drop in the lines could save fuel and maintain the car speed the same as formerly, by reducing the station voltage and adding copper to decrease the line loss. The line loss question is very aptly illustrated by an ordinary car controlled by a rheostat. Suppose the rheostat resistance be taken up to represent the line resistance. When the rheostat is in circuit the car does not require any more power than if it was out, provided the car is not accelerating in speed. There is of course a waste of power, but it acts simply to decrease the speed, and does not affect the power house. As long as the station voltage is kept constant, an increase in the line loss cannot increase the power required at the station to move a given number of cars.

The employes of the Galesburg Electric Motor & Power Company have organized a relief society.

### THE HEILMANN LOCOMOTIVE.

The Heilmann locomotive which is being experimented with in France, although an engineering monstrosity in itself, may possibly do some good in the way of education as to the possibilities of electric locomotives. As it now stands it is about as complicated and difficult to manage a pile of mechanism as could be devised for the purpose. The storage battery is a complication which has not been introduced however, which seems rather strange when the complexity of the present machine is considered. It consists of a dynamo engine and locomotive boiler mounted on two eight wheel trucks. Each axle is provided with a gearless motor. The engine and dynamo

and crank rods counterbalance each other. The nominal horse power of the engines and boiler is about 1,200, and the motors are to correspond. The fuel and water is carried alongside the boiler in compartments, as shown in the engraving. The stack is at the rear, to improve the draft. The length over all is 52½ feet. Some idea of the simplicity of the machine can be gained from the

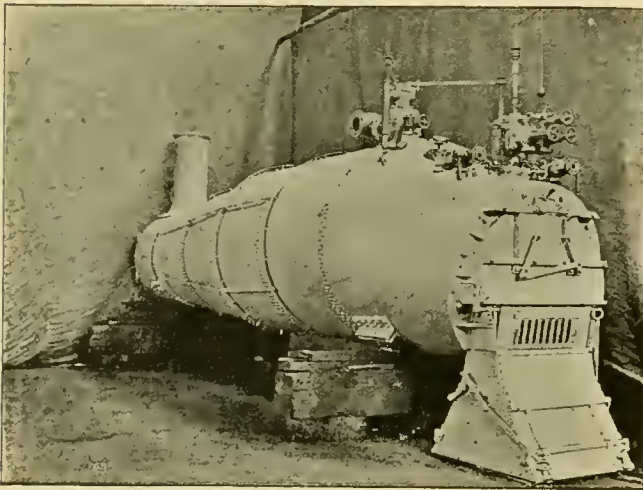

BOILER; 26 FEET LONG; 6 FEET DIAMETER.

drive the motors. Besides this there is another small engine and dynamo to excite the fields of the large dynamo. The supposed advantage of this arrangement over an ordinary locomotive is that the engine can be running at full speed and developing its maximum horsepower when starting the train. The total weight is 110 tons. The engine is a cross compound, and the two cranks are 180 degrees apart. The cylinders being placed at opposite ends of the frame. The advantage of the 180 degree arrangement is to have the two pistons

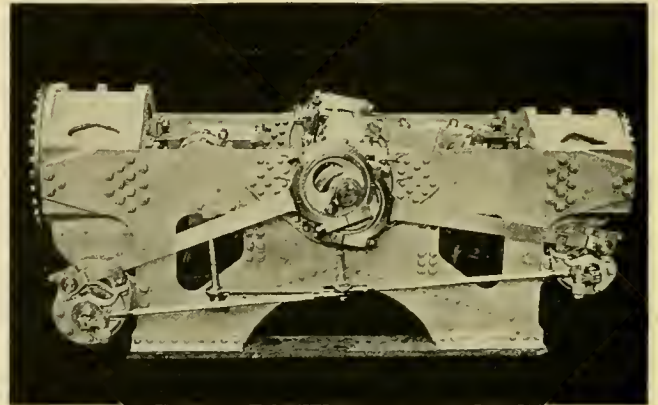

ENGINE—HEILMANN LOCOMOTIVE.

crew it takes to run it, as described by a correspondent of London Engineering. First there is the pilot to tend to the Westinghouse brake. (It must be a troublesome brake). Then there is a man to work the switches controlling the motors, the dynamo field and the steam lever. Another man tends the exciter engine and the fireman has an assistant breaking coal. There are three oilers, besides the chief engineer, so that eight men are on duty. As said before, the designers seem to have set themselves to make things as complicated as possible. By using a good self contained engine and throwing away the separate exciter and engine, the same results could be very much more easily obtained. The dynamo could have been shunt wound and its voltage regulated by a rheostat in the field circuit. This rheostat would be all that would be necessary to control the motors at all speeds. Two men ought to be able to handle all the machinery on the locomotive, had it been built on common sense principles, and this without any loss in fuel economy

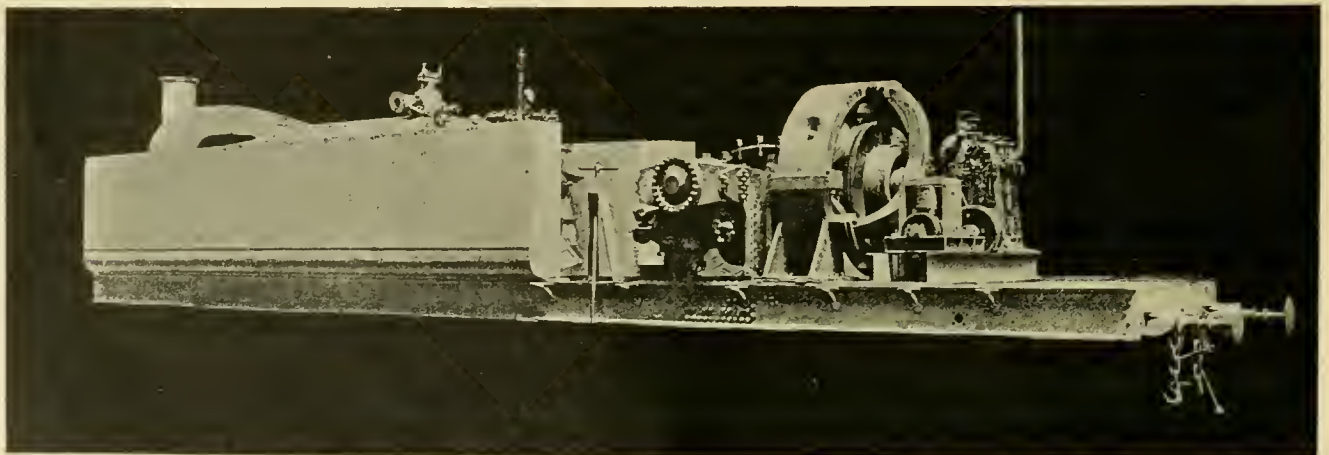

over the present form. Why it should be built with such an array of steam levers, series-parallel switches and other ornamental, but not useful apparatus, is beyond

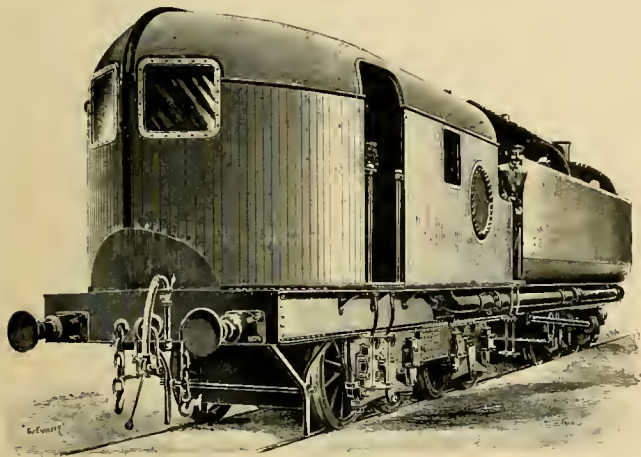

FORWARD END, HEILMANN LOCOMOTIVE.

our comprehension, unless it be with the purpose of giving employment to a few more Frenchmen. The speed attained in the trials so far is about 74 miles an hour. It is being gradually increased in each trial.

“These figures serve to show how utterly absurd it is to bond a track of seventy-pound T rails with iron rail bonds No. 4 or No. 0 in size, and to pretend to reinforce their conductivity with a No. 0 iron or even a No. 0 copper wire. It is like laying a twelve-inch water main and then putting a one-half inch pipe alongside to help it out. The No. 0 B. W. G. copper wire has a resistance of over twenty times the single track of fifty-six-pound T rails per foot, and the No. 0 B. W. G. iron wire over 112 times the resistance per foot of the same track. How, then, can either of these be of any adequate assistance for conducting current?”

“The writer knows personally of several instances where the copper supplementary wire has absolutely disappeared. The writer believes that ninety-nine per cent of the money expended for so-called supplementary wire is absolutely thrown away. The same money expended in other directions will give some adequate return. Does not this show conclusively that we should give our attention to the more perfect bonding of the rail joints, and also to apply track feeders in such a manner as to fully utilize the conductivity of the track and thereby make it fulfill the service of which it is capable when properly treated?”

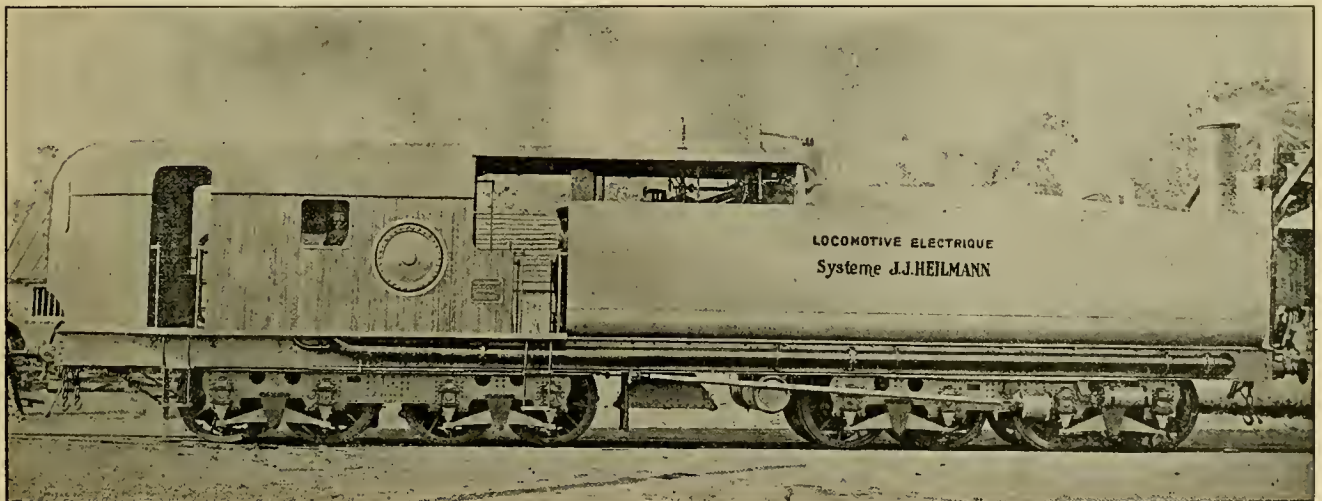

THE HEILMANN LOCOMOTIVE.

**J. H. VAIL ON RAIL BONDING.**

The paper on “The Importance of a Complete Metallic Circuit for Electric Railways,” read at the National Electric Light Association, by J. H. Vail, was accompanied by some practical examples of bonding, in the shape of bonds manufactured by the Electrical Engineering and Trading Company, Edison building, New York, of which Mr. Vail is president. The bond is here illustrated. We cannot refrain from quoting a few words from Mr. Vail’s paper in regard to the importance of heavy bonds above everything else in a return circuit although we have mentioned it so often before. After giving a table and a chart, showing the relative conductivities of rails and copper wires, he says :

**A CABLE ROAD PATENT VOID.**

The Pacific Cable Railway Company recently brought suit against the Butte City Street Railway Company for the infringement of the Hallidie patent by the use of a “dummy” grip car or truck to assist on steep grades and where only a part of the road is operated by cable. The suit being lost by the Butte City Street Railway an appeal was made and the decision reversed, the court holding that in the state of the art at the time the patent was issued it did not involve invention.

THE WESTINGHOUSE COMPANY has closed a contract with the West End Street Railway of Boston for 150 motor equipments and 50 more if needed.

RAILROADING ON WIND.

The Chase-Kirchner Aerodromic System of Transportation.

A good many railroads and some street railways have been constructed on wind, but we have yet to learn of any of them operating on that very unsubstantial substance. Under the title of "The Coming Railroad" Lieutenant G. N. Chase and H. W. Kirchner, of St. Louis, Mo., announce their radical departure from established methods and one which they claim is soon to revolutionize the world. They term their system the "Aerodromic," and the problem which they undertake to solve is the construction of a machine which shall be able to run upon the air at great speed, guided by a track. The principle is based upon the flight of a bird, especially in the act of soaring, the comparison being made that a bird with an initial velocity of 22 feet per second, soaring one

ping and acceleration to starting. Car to be from 40 to 100 feet in length, and grain and coal cars to be hopper shape and discharge through the bottom. The details of electrical propulsion involve nothing new, but upon the top of the car are to be placed the set or banks of aeroplanes, arranged in form as indicated in the illustration. The area of such surfaces according to the load vary from 2,000 to 4,000 square feet. These planes are hinged at the rear edge to an immovable standard perpendicular to the top of the car, and controlled by linked levers, so that the planes in each bank may be operated simultaneously by the engineer and capable of being set at any angle from zero to 10 degrees or more. Each plane to be from 20 to 30 feet in length and from 4 to 5 feet in

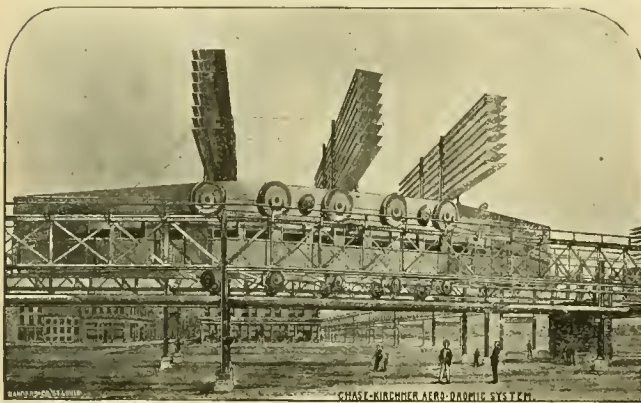

CAR UNDER FULL SAIL.

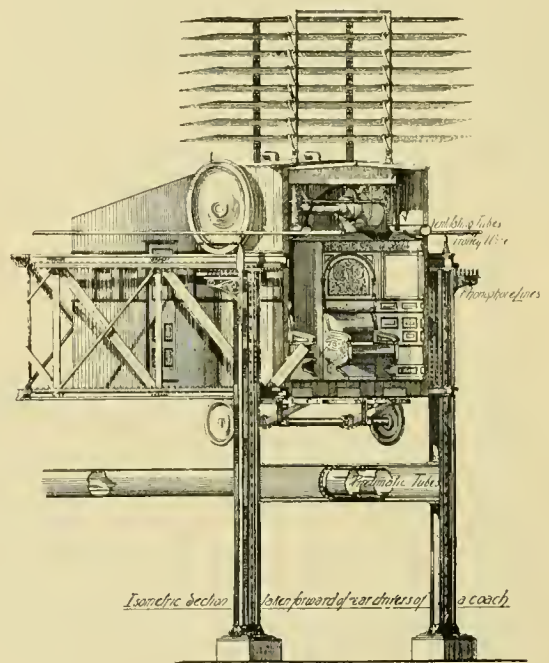

CROSS SECTION OF CAR.

minute, will cover 1,200 feet on an average velocity of 20 feet per second, and that the bird can sail down an incline of 11 feet per mile indefinitely and at a speed vastly in excess of that possible by the expenditure of the same amount of work in other means of transport. It is stated that new experiments show that if in such aerial motion there be given a plane of fixed size and weight, inclined at such an angle and moved forward at such a speed that it shall be sustained in horizontal flight, then the more rapid the motion is, the less will be the power required to support and advance it. The contemplated structure for this system is an elevated track of steel consisting of two parallel trusses

width. A hundred and fifty miles per hour is to be a practicable speed. The authors of the system have published a very complete and readable pamphlet, describing the principles involved and the possibilities of construction and operation. They do not however make any provision for a large number of difficulties, among which might be mentioned that the sleet and the snow forming upon the aerial planes and by freezing and

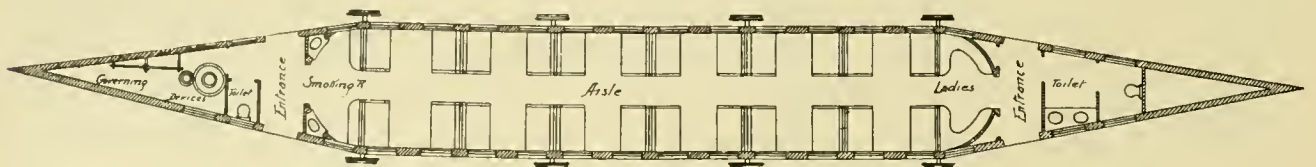

PLAN OF CAR.

6 feet in depth and 11 feet apart, the upper and the lower chords of these trusses forming the rails. The track is required to be a practically straight line, although curves may be introduced at stations which are also elevated somewhat, in order to give retardation in stop-

weight, prevent their being of any use. As a curiosity its suggestions are interesting, but as possessing any practical merit, it would seem that the air ship minus the air and propelled simply by electricity will always be better.



**THE UNRELIABLE AND MISLEADING DAILY PRESS.**

With all due credit to our great American dailies for enterprise in news gathering, they are not without great reproach in many ways. In dealing with corporations, particularly the common carriers, they delight in thrusting the barbs into the corporative body solely to please the populace, which seem never weary of the sight of blood. While many times, published articles which are the acme of falsehood and even impossibility, can be excused on the plea of getting the forms to press at an inflexible hour, the chief cause for censure lies in the fact that apparently no effort whatever is made to corroborate the truth of such information.

For instance, the daily and weekly papers are still harping on electrolysis and its dangers and destructive powers, when in fact this electrical disease was met and worked out promptly by electricians as soon as it became known. Electrolysis now gives the electrical engineer no more cause for uncertainty and doubt than the probability of a thunderbolt from the sky striking at the same water and gas pipes. But the news press has heard of dangers which while in existence once, no longer threaten, but seems unable or unwilling to learn that in this age of progress a few months work revolutions and solves hard problems with a certainty and rapidity formerly unknown.

The most glaring instance, however, and the one which calls forth these lines, is an item which we have traced in nearly 100 daily and weekly papers, most of which are published in cities where street cars are in operation and where reliable confirmation or denial could have been quickly secured by the use of the telephone.

For example note the following:—

IN Winnepeg, Man., an electric railway company with twelve miles of road sells fifty tickets for \$1, and last year carried 1,500,000 passengers, finding the low rate profitable. In Detroit the question of eight tickets for 25 cents is under discussion, which led to an official verification of the truth of the Winnepeg report.

“Sells 50 tickets for \$1. \* \* \* finding the low rate profitable,” “which led to an official verification of the truth of the report.” These statements coming from a paper of standing, naturally carry great weight and are sufficiently convincing to a public already educated by these same journals and predisposed and anxious to accept such statements. In this way a strong public sentiment is created almost impossible to convince to the contrary.

Now what are the absolute facts. The REVIEW has investigated the case with the following results. There are two street railways in Winnepeg—the older one a horse line; the other an electric. They parallel for a large part of the route and in the business district. The horse road claims an exclusive franchise on all the streets in the city, and has been in litigation nearly two years, the case having now reached the Privy Council, in

England, where a decision is daily expected. On February 12, 1894, the 2-cent fare was first put in effect on the electric line, and when our Annanias brethren stated on “official verification” that it had prevailed twelve months, had been in force three weeks. The company do not find “the low rate profitable” although they are carrying their former and most of the business of the horse road, and could not keep present rates up indefinitely. As one of its utensils of war the 2-cent fare is an excellent piece of artillery but in times of peace would be suicidal. There is a good business for one of the two roads but not enough to warrant both. On forty-nine out of fifty roads on this continent passengers cannot be carried for three cents and pay expense of such operation as the American public demand, to say nothing of interest on legitimate bond issue; while improvements and dividends are out of the question.

**AERIAL RAILWAY AT GIBRALTAR.**

A suspended cable railway has recently been installed at Gibraltar to connect the signal station on the cliff with the south end of the town. The station could formerly

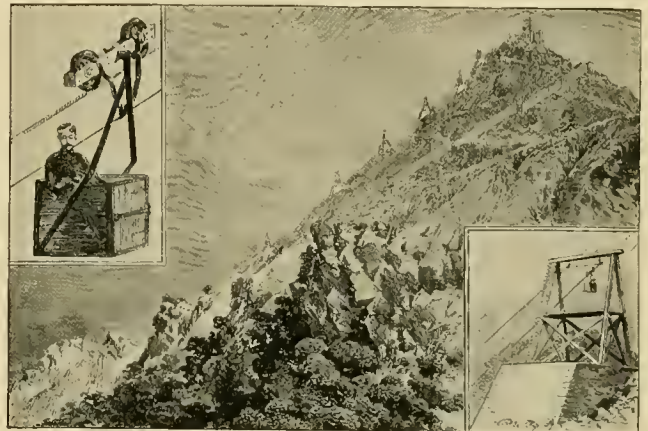

be reached only by a laborious climb. The span is 300 yards to the edge of the cliff, at which point a high trestle is erected to keep the cable in the air until it reaches the top. The “road” has one supporting and one propelling cable. It is used for both freight and passengers.

**BROOKLYN ROADS.**

The rumors of consolidation and sale of the Brooklyn systems have been so numerous for some months past that little seems to be known about the actual condition of affairs. There has been no consolidation in a legal sense. The Long Island Traction Company, which is simply an investment company, owns the Brooklyn Heights Railroad Company. The Brooklyn Heights Railroad leased the Brooklyn City in February 1893. The Long Island Traction Company also owns the Brooklyn, Queen’s County and Suburban, which latter road recently purchased the Broadway, Ferry & Metropolitan Avenue Railroad and the Jamaica & Brooklyn Railroad.

## RETURN CIRCUITS.

Abstracts from a paper read before the New Orleans Electric Society, by H. J. Malochee.\*

In addressing you this evening it is more particularly with the idea of courting discussion than of telling you anything new or saying something which is not already a subject of general knowledge. \* \* \* A large number of electric railroads use, to-day, the earth as the return circuit for the entire current generated, the rails serving but a secondary purpose. It is evident that the portion of the circuit, from the motor to the dynamo, is dependent upon quite a number of conditions, connections, and joints, viz.:—the connection of the rails with the ground plates, that of the ground plates with the earth, the condition of the earth as far as dampness, conductivity of strata, etc. are concerned, the junction of the ground plates at the station, and the connections from the latter to the machines themselves. The conductivity of the earth, a most important factor in the circuit now under consideration, is very unreliable and unsatisfactory, and is dependent upon too many climatic and local conditions, to be considered seriously in connection with any new installation by any well informed engineer. Take in consideration the capacity necessary to carry 1000 amperes of current or more and you will see that the earth can not be depended upon as a return circuit.

Let us consider in detail the troubles liable to arise, and the losses that may be suffered. First, it is expensive in first cost to make a thoroughly good connection between the rails and earth; second, the amount of energy lost is varying but must, of necessity, be a large factor in the operating expenses; third, the very good chances for the possible increase of resistance to such an amount as to make the cars run very slowly, and the lights burn very dimly; fourth, the constant wear and rust of the rails by electrolysis, between them and the earth; fifth, the probable law-suits by the persons or corporations whose property is damaged by the effects spoken of above. These and several other possible causes for dam-

\*H. J. Malochee, consulting electrical engineer, of New Orleans, is a native of that city, where he was born in 1865. After finishing a high school education he went into a machine shop as an apprentice. Completing this service in 1885, he entered the engineering course of Tulane University in Louisiana, graduating in 1889. While there he was appointed instructor in drawing, which position he held four years. During the summer vacations of '87 and '88 he worked as machinist in the Southern Pacific Railroad shops, getting a good idea of the requirements of railroad work. Leaving the University in 1889, he immediately entered the service of William Oswald, agent of the Edison and Sprague companies, as superintendent of construction. Last June he resigned to start for himself as independent consulting engineer. He is secretary and treasurer of the New Orleans Electrical Society, a flourishing organization of 100 members, 75 of whom were secured through his own personal efforts.



H. J. MALOCHEE.

age and losses, make me believe strongly in the advocacy of the all metal return, not by means of supplementary wires, not by means of overhead return feeders, but, by the simple use of the rails themselves. \* \* \*

Suppose we take as an example, a double track road with 90 pound rails such as are used in all large cities. These rails being each 9 square inches in cross section, and iron and copper being as 1, to 6, in conductivity, the equivalent in copper would be  $1\frac{1}{2}$  square inches, and the four rails together would equal 6 square inches of copper in cross section. The carrying capacity of this conductor would be at least 6,000 amperes. As compared with 0000 wire in order to have the same conductivity, the number of wires of this size required would be more than 28. Just think of it! 28 Number 0000 wires bunched together! How ridiculous it does sound to hear some people speak of using one number 0, wire or one number 00, or even two of the latter size as supplementary wires, when we have as an absolutely necessary part of the equipment such a splendid path for our current.

It grows the more striking when we compare the actual sizes of these would be supplementaries and of the rails in terms of circular mils.

Thus: 1	Number 0	equals	105,543	circular mils.
1	"	0000	"	211,600 " "
2	"	0000	"	423,200 " "
1	copper bar,	6 square inches,	equals	7,639,000 circular mils.

It being admitted therefore, that the rail is the proper thing to use if it is possible to make it electrically continuous, the problem then resolves itself into properly bonding the joints or otherwise reducing their resistance. For this particular purpose numerous schemes have been devised, and in order to give a better idea of the improvement in this line I will take up these devices in their historical order.

The first idea was the driving of a pin in each rail, wrapping a number 4 B. & S. wire around it and soldering. This was of course too unmechanical and temporary to be used very long and I believe that probably not one road out of a hundred could be found thus equipped to-day. Then came the channel pin, which consisted of a tapered pin with a channel in it for the reception of the wire; this pin was then driven in a hole in the web of the rail, but this, apart from the poor contact made by the wire is very objectionable on account of its liability to get loose from the constant vibration caused by the passing car wheels, it is also bad on account of the chances for moisture to get in between the iron and the copper, rust the joints out and so on.

After the channel pin came the split bushing, which nearly encircles the whole of the bond wire, and is better mechanically than the former joint. However, in an electrical sense it is not as good for the reason that there are four joints between rail and rail and the moisture can also get between the iron and the copper, and by electrochemical action injure the connection very seriously.

The welding of rail joints was next tried, and probably if this plan was carefully carried out by means of the electric welding of the entire cross section of the rail,

instead of joining only a portion of it as was done, this method would be most excellent both in a mechanical and electrical sense. Since the welding of rails was found not to come up to expectations, there have appeared several bond wires which are a very great advance over the old ones; and these I will now take up. They are the solid end bond, the hollow rivet bond, the Acme, and the Vail bonds. The solid end bond is made in two sizes,  $8\frac{1}{2}$  and 30 inches long. It consists of one single piece of from 0 to 000 wire at each end of which a rivet head and body is formed; this piece is riveted into any portion of the rail in which it is thought best to insert it. The rivet portion of the bond being larger in diameter than the wire itself, the contact with the iron is larger than in the primitive styles of bond wires; further this contact is made still larger, by the fact that the rivet head and that formed by the riveted end are pressed tightly against the side of the web by the riveting, thus forming perhaps as perfect a joint as can be made by the use of a rivet.

The hollow rivet consists in having, instead of a solid rivet at the end, a hollow wire whose outer surface is forced against the walls of the hole in the rail by a tapered iron pin which is hammered into the hollow end of the wire; this end, being split a short distance, may be turned over so as to prevent its getting loose or the pin from backing out. This is mechanically very strong and, if the surfaces are bright, there should be a very perfect electrical joint due to the fact that the metal is pushed outwardly at the same rate in every direction, and the two metals can be so clamped together as to form a very intimate connection inside of the hole. In this bond, the size of the outer diameter of the part which goes into the rail is necessarily much larger than the wire itself, and the electrical connection is thus made far more perfect as will be explained later on.

A very recent addition to the number of good rail bonds is the "Acme" bond, which consists of an iron sleeve with a tapered end. This sleeve has a channel cut on the side, thus making the wall of the sleeve rather weak in that particular place. The hole is drilled about 1-32 of an inch smaller than the largest outside diameter of the sleeve and when this latter is driven over the wire, in the hole in the rail, the connection is made very solid and the material in the sleeve shapes itself to all the inequalities in the hole and on the wire.

The Vail bond has been but very recently designed by J. H. Vail, and is probably one of the best on the market. It is substantially made and contains a number of advantages which few others have. It consists of two heavy sockets of copper, one on each rail, and connecting cables of copper wire between the two. The sockets have two or more studs which are riveted into the web of the rail and these, together with the shoulder, when the bond is in position, furnish quite a good electrical connection, provided of course the work is done in a thorough manner and the surfaces were bright at the time of their connection.

Each of these bonds has its own peculiar advantages, but the special, and by far the greatest advantage of these

last described bonds is the increased area of the join with the rail. In considering the general subject of resistance at the joint, we certainly cannot fail to remember that iron has about 1-6 the conductivity of copper and therefore the area of the junction surface should be no less than six times the area of the copper wire. This result can of course be reached either by increasing the diameter of the wire or by lengthening the joint. This latter is difficult to do and it would be costly as compared to the first method. If we adopt the scheme of increasing the diameter, what would be the result of doubling the diameter of the bond wire at the point where it connects with the rail? Suppose we have one number 000 copper bonding wire connected to two rails by holes in the web, this part being  $\frac{3}{8}$  inch thick. The area in square mils of number 000 B. & S. wire being 131,790, the area of the joint should therefore properly equal 7 times 131,790 square mils. The joint if made with 000 wire  $\frac{3}{8}$  inch long equals the diameter, (410 mils) times 3.1416 times 375 mils equals 483,000 square mils. As we want an area equal to 6 or 7 times 131,790 or 921,530 square mils, we can get at that area immediately by doubling the diameter of the wire, and the joint will have an area equal to twice 483,000 square mils, or 966,000 square mils, which makes the conductivity of the iron portion of the joint equal to that of the wire itself. However, what is the conductivity of this wire as compared with that of the iron rail itself? Take a 70 pound rail which is 7 square inches in cross section and whose value in terms of copper is 1-6 square inches. This bar of copper  $\frac{1}{2}$  inch thick and  $\frac{2}{3}$  inches wide has a section equal to 1,166,000 circular mils, and the 000 wire has a cross section of 167,805 circular mils, thus it would take 7,000 wires to equal the conductivity of the rail and make it electrically continuous. Whether the 7 wires should be used or not would have to be determined by the number of cars to run, and the distance from the power house, etc. In general, I should say that the very heaviest bonds would have to be nearest the dynamo and the lightest at the farther end of the line. Still, each installation would have to be treated independently according to the special circumstances surrounding it; but, in general, it seems to me that when considering the installation of an electric street railroad the same attention required for or given to the overhead feeders, is needed for the return circuit; and this means that the bonding of the rails should be such that the drop of voltage be the same at any point on the return, thus establishing the fact that the bonds are a function of the distance, and the number of cars on the line further away from the dynamo.

Yet, the important position of our work is not confined to the size of bond wire, or the number of such wires we shall use. Their connection to the rail is as important if not more so; for, if we choke the current at the joint, there is heating and electrolysis, and the bad connection is made worse and worse as the current is carried through it.

A suggestion which was made some time ago and which should receive some attention in my opinion, is

the increase in the length of the rails; this would decrease the number of joints per mile. \* \* \*

Another suggestion which seems to be very important, is one recently made by Professor Brown Ayers, of Tulane University: viz: The electric welding of the bonds to the rails. This means of connection is most important, for certainly if we use a bond no matter how large, if we make the area of the connection large enough to counteract the lesser conductivity of the iron, still, if the real jointing of the bond with the rail is not perfect and permanently so, the above provisions for a good return circuit are of little avail. The small cost and the light weight of the electric welding machines necessary for such work would make this further provision a very practical remedy for any trouble from electrolysis at the joint, rusting out of the same, and the consequent increased resistance of the bond and rail joint, which after all neutralize any other provision that may have been made to increase the conductivity of the entire return circuit. This method has the advantage over the welding of the rails themselves in so far as the flexibility of the joint is retained and yet the continuity of the metallic circuit is preserved.

Another thing to which I desire to call your special attention is the difference which exists between the various lengths of bond wires, in so far as resistance is concerned. For example, the number of  $8\frac{1}{2}$  inch bonds necessary for one mile of single track have a resistance of .00885 ohms: whereas the 30 inch bonds for the same track would have a resistance of .0265 ohms. This is for number 0, B. & S. wire. The loss in volts due to the resistance of the bonds themselves, independent of any loss in the joints, would be for that distance, with 100 amperes of current and the  $8\frac{1}{2}$  inch bonds, .88 volt and with the 30 inch 2.65 volts. Thus it would seem that the appliance in that direction is the one which combines shortness and large carrying capacity. We have now a good return by means of our well bonded rails; the next thing to consider is how to connect these rails to the dynamo. It is certainly necessary that the carrying capacity of this portion of the return circuit be large enough to carry the entire quantity generated by the dynamos, and this should be done with a very small loss. Too little attention has been, as a rule, given to this portion of the work and truly none demands more careful attention and consideration. Were we called upon to design a system of piping, we would certainly not think of connecting a 3 inch pipe to carry steam to an engine when it should have a 12 or 15 inch pipe. Why then should we connect say 4 number 0000 wires which have a combined cross section of 846,000 circular mils to a track which has in the case of four 90 pound rails an area of 7,639,000 circular mils; in the case of four 70 pound rails an area of 5,940,000 circular mils; and in the case of four 60 pound rails an area of 5,090,000 circular mils. The compared resistances per 1000 feet go further to prove the folly of such a piece of work. The combined resistance of the length of four 0000 wires is equal to .01253 ohms, whereas, that of the same length

of 90 pound double track is .00138 ohms, of 70 pound rails is .00178 ohms, and 60 pound rails .00196 ohms.

Is the cost of thorough bonding excessive and prohibitive? Figures will answer this question. One mile of 0000 wire weighs 3,380 pounds, at 15 cents per pound, or \$407. This is the cost of the supplementary. Now, 176 bonds 30 inches long weighing 275 pounds, at 15 cents will increase the cost \$45, making a total of \$452. As a comparison I will give you the cost of the longest bonds used, say 3 feet of wire number 0000. We have found that in order to make the 90 pound rail electrically continuous, we must have 7 of these wires bunched together, this equals 21 feet at each joint, making for the 176 joints in the rail a total of 3,700 feet, weighing 2,370 pounds, at 15 cents per pound, or \$355. Thus the cost for material is less for heavy bonding as compared to light bonding, and one 0000 supplementary wire, but the cost of manufacture being probably higher for the special form in which this material is furnished, it is reasonable to think that the entire cost in the two cases would be nearly the same. However, when it is considered that in one case the circuit has a conductivity of 7, and in the other a conductivity of two at the most, no manager would hesitate an instant to adopt the latter method, even if the cost is higher.

What are the conclusions that seem to have been reached? First, we must use our rail for a return circuit. Second, we must make this circuit of greatest conductivity and least resistance. Third, our bonding wires should be of the same carrying capacity as the rails. Fourth, the connecting surfaces of these bonds with the iron rail should be no less than seven times the circular mileage of the bonds themselves. Fifth, the connection electrically speaking should be as perfect as possible, so as not to cause electrolysis at and destruction of the contact. Sixth, the connection from the rails to the dynamo should be amply large, to carry the current which it is intended to carry with practically no loss in that distance. Seventh, the entire cost of a good rail return is no more than the return by means of a supplementary and light bond wire.

---

#### HAS PLENTY OF COMPANY.

---

"Yes, we have been favored as to the weather," said a well-known manager as he gazed at the rapidly descending rain. "Last winter we had plenty of hard weather, but our receipts were large. This winter we have had good weather, but the receipts are rather smaller and there does not seem to be much improvement. I think sometimes of leaving the street railway and going into the shoe business. There must be money in that these days the way people are walking."

---

THE twelfth half-yearly analysis of the accounts of the principal tramways in the United Kingdom has been issued by R. S. Tresilian, of the Dublin United Tramways Company. It is for the year ending Dec. 31, 1893.

## THE LIFT BRIDGE AT HALSTED STREET, CHICAGO.

Only One of Its Kind in the World—A Place Where Street Cars  
May Come High.

Halsted street, Chicago, is said on good authority to be the longest continuous city thoroughfare in the world. It now enjoys further distinction in having a unique lift bridge over the Chicago river, where South Halsted crosses the pure and purling current of that famous stream.

The bridge is a decided innovation, being a straight

piston is forced into the cylinder the rapidity of the flow of the liquid varies as it is pressed into a separate reservoir made for that purpose. The flow is graduated to suit the rapidity of the approach of the bridge by means of tapering plugs. The lift section is 64 feet wide, over all, of which 12 feet on either side are for foot passage, leaving a 40-foot roadway to accommodate the street traffic and the double tracks of the West Chicago Street Railway Company. When the bridge is at its highest point a clearance of 155 feet above the water is secured.

The lift is operated by a separate power plant situated under the north end of the bridge. The plant is a duplicate, consisting of two 75-horse-power Crane Elevator

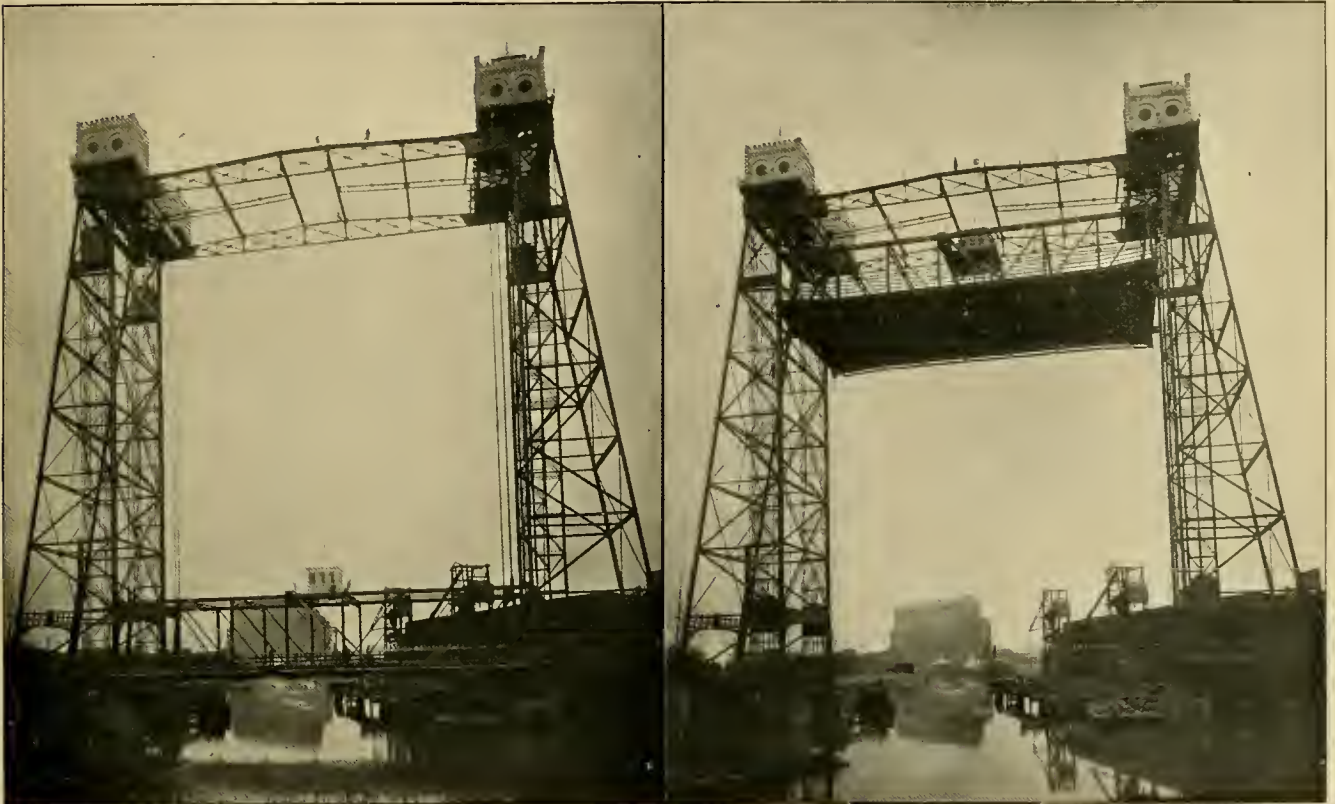

THE HALSTED STREET LIFT BRIDGE—196 FEET HIGH.

lift of the entire draw, sufficiently high in the air to allow the passage of vessels, as shown in our engraving.

The plan of the bridge requires two towers, 196 feet above the river level and 177 feet 7 inches above the street level. Each tower supports at the top four sheaves each 12 feet in diameter. Over these pass thirty-two  $1\frac{1}{2}$  inch steel cables, which are attached to the top chords of the bridge on one side and to counterbalancing weights on the other. The bridge (lift section) is 122 feet long in the clear and weighs 300 tons, consequently the counterbalances, which are iron, are of the same weight. At the upper and lower extremities of the tower are placed hydraulic buffers. The buffers are cast cylinders of 14 inches diameter, filled with glycerine and fitted with a  $3\frac{1}{2}$ -inch piston rod, against which the lift sections strike in raising and lowering. As the

Company's engines and two 70-horse-power boilers. This amount of power is by no means necessary to raise the bridge however, only enough power being used to overcome friction, with additional power for any traffic that may be upon the bridge at the time. Two men, an engineer and a bridge-tender, will be the working force, and a code of electric signals is arranged for communication. So delicately is the great draw balanced that the power of one man can raise it should emergency require. In addition to the iron counterbalance, four tanks are attached to the lift span proper, which can be filled with liquid or emptied so as to make the adjustment of the weights of the bridge and counterbalance more perfectly equalized. The tanks are provided with gas jets to thaw them out in case of frost.

The structure was completed in a space of thirteen

months and opened for traffic March 21, 1894. The builders state the work could be duplicated in nine months easily, the various problems which were encountered in such a novel design being now thoroughly worked out.

The time required to lift the bridge the full height at full speed is 45 seconds, or at the average rate of 210 feet per minute. The contract called for 85 feet in 50 seconds.

The designer of the bridge was J. H. L. Waddell, bridge engineer, of Kansas City, Mo., and the builder was the Pittsburg Bridge Company, of Pittsburg, Pa., through W. W. Curtis, C. E., of the Western office, in the Owings building, Chicago.

The lift bridge was made necessary as the Secretary of War refused his consent to the construction of a draw bridge with a pier in the center of the river, and there were objections to the bascule type, while the ordinary swing draw would have destroyed a large amount of valuable dockage in which to turn. The bridge cost \$200,000, and is the first of its kind. Its advantages include economy of first cost and operation; has all the merits of a fixed bridge, including granite floor paving, if required; is exceedingly stiff, rapid of movement and free from danger of collision.

#### THE DOANE LIGHTNING ARRESTER.

The Doane lightning arrester is a combination of two such old and well-known principles that it is almost a matter of surprise that they have not been combined in marketable form before.

In the majority of arresters the line is momentarily grounded and short circuited through an arc which forms when a discharge takes place.

The flow of current is consequently large. In another type of arrester the line is permanently grounded, during thunderstorms, through a high non-inductive resistance. In the Doane railway arrester the discharge passes through a 100-ohm non-inductive resistance in series with the arc. It is thus impossible for more than five amperes to flow, and the arc formed is easily put out. Referring to the engraving, the arc is formed between the two adjustable carbon points at the bottom. The flow of current energizes the magnet which attracts the arm. At the lower end of the arm is a blade of suitable material, which comes between the carbon points and breaks the arc. The W. S. Hill Electric Company, of 133 Oliver street, Boston, is the manufacturer.

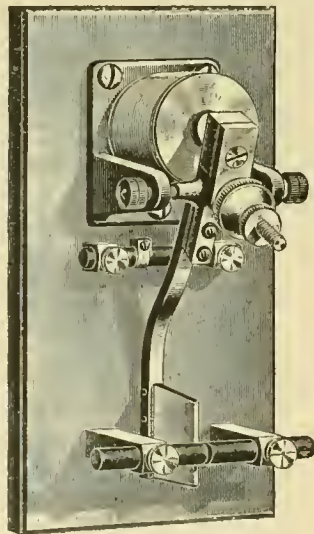

#### ELECTRIC CARS AS NEWSPAPER CARRIERS.

We have all noted the facility and success with which electric cars have been adapted to the general carrying trade of other than passengers, and the descriptions from month to month of electric baggage, electric mail and express and electric funeral cars have afforded some of the most interesting and suggestive articles in this magazine. Last month was recounted the progressive policy of a Pittsburg daily, which charters a special car on the McKeesport & Wilmerding electric railway, and in this way beats its competitors into several towns by some four hours.

The enterprise, however, is not the only one of its kind. The Attleboro, Mass., Daily Sun, uses the interurban line running from city, to its own and the readers' great advantage. Formerly when bundles of dailies for North Attleboro, South Attleboro, Pawtucket and several other towns and villages were sent out on the steam trains it frequently occurred that the forms were a few minutes late in going to press and the connection was so close the train would be missed and papers had to be sent out in wagons at considerable expense and still more valuable loss of time. The new regime is to bundle the papers, which are piled up around the motorman and delivered to carriers at distributing points. As the electrics run at frequent intervals the occasional failure to catch a certain car causes no serious delay. The arrangement has been in force some months and has proved a great success.

The manager in charge also adopted a novel method of securing new subscribers. The route along the road is closely built up between the towns, and armed with several hundred copies tightly wrapped in heavy paper, the circulator made a trip for ten days, throwing off a sample copy at each door as the car sped by. The novelty of the scheme caused residents to pick the paper up and peruse it and at the end of the free distribution period it was an easy matter to canvass the route and enlist a large number of subscribers who wanted the good work continued right along. This plan is specially adapted to thickly populated interurban lines and can be worked to excellent account on nearly all such roads. The possibilities of electric cars are only beginning to dawn on people, and managers should carefully study the particular opportunities of their respective localities and find out what popular innovation can be worked out in their own case, thus increasing revenue and popularizing the road.

THE CLEVELAND MECHANICAL STOKER AND ENGINEERING COMPANY, of Cleveland, O., of which the well-known Alfred G. Hathaway, is secretary and treasurer, is meeting with great success in marketing its stoker, which is claimed to make a saving of over 20 per cent in fuel and to reduce smoke to only 10 per cent. The Hathaway transfer table still holds its own, and many foreign and domestic shipments attest its continued favor.

## PRINCIPLES OF THE TAYLOR TRUCKS.

The wear on the truck of an electric car is usually equal to if not greater than that on steam railway trucks, as the strain of starting and stopping and turning curves more than makes up for the difference in speed.

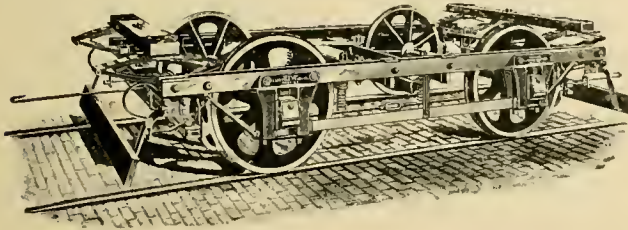

The Taylor truck people believe that practical experience should be followed in motor truck construction in distinction to plausible theory, and have incorporated this belief in the construction of their trucks. The steam roads have long known the value of the elliptic

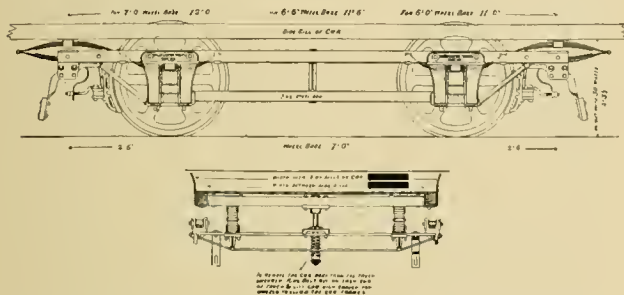

spring as giving great elasticity and ease of riding on passenger coaches. The Taylor company makes a strong point of the use of elliptic springs in its trucks. The car body is supported entirely by elliptic springs. The frame is so strong that intermediate spiral springs are not needed.



An interesting experiment is here shown, proving the strength of the side frames of the Taylor truck. These trucks are designed so that each one is an independent and complete construction connected to the car body by king bolts as on steam roads.

A TASTY and appropriate floral offering at the funeral of a veteran employé of the West End Street Railway of Boston, lately, was a car made of violets and ivy leaves and bearing the words "Transfer" and "Brookline," the name of the last car driven by the deceased. It was presented by fellow employés.

## EXPERIENCES OF A SUPERINTENDENT.

By C. P. Young.

### PART IV—REPAIR SHOPS.

Is it or is it not necessary and profitable for electric roads to do their own repairs? Now we have two classes of motors, the old double and the new single reduction. We have roads with all the way from two to over one thousand cars. Notwithstanding the great difference in numbers of cars that the various roads may have, I unhesitatingly say that all electric roads should have a repair shop, the same to be equipped according to the number of cars. Let us take for example a road with fifty cars that yet runs its old double reduction motors. The power house, machine shop and repair car barn should, if possible, be in close proximity to each other. Machine shops should be light, airy and comfortable, and contain a six to ten horse-power motor to run the shafting; a good lathe equipped with one small and one large combination chuck, with a half inch drill chuck (say the Almond) fitting a shank so that it can quickly be changed, to be used also in the drill press; a full set of not less than forty turning tools of various kinds; a full set of taps and dies from  $\frac{1}{4}$  up to 1 inch; a separate smaller set of taps and dies; a small lathe for bolts, facings of nuts and for turning smaller detail parts that may be needed for engines, etc. Then a good upright drill press, an emery-grinder and a good grindstone; a solid bench with one large strong vise and a smaller one for light and quick work; a full set of various kinds of files and assorted twist drills from  $\frac{1}{8}$  to  $1\frac{1}{4}$ ; a few wrenches and a half-dozen assorted chisels. These tools are necessary to repair and make worn out parts of motors and trucks.

The following detail parts can profitably be made: All kinds of brasses, trolley wheels and pins, brush-holders, rocker arms, collars, all detail parts for controllers, bolts and fitting of same, countershafts and oil cups (if they are used) and armatures and fields. I think gears and pinions can be bought cheaper and are more accurate than home-made, as an expensive milling machine is necessary. Steel gears only should be used. All brasses should be made of the very purest and best bell metal, as that composition lasts longer and heats less. All bolts in trucks and motors should be made of mild machinery steel, and every bolt should not only have a good lock nut, like, say the Nacional, but also have a split pin fitting close up against face of nut. Keys should

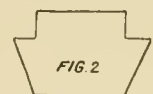
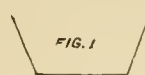

all be of machinery steel, and let me say here that to fit a key perfectly requires long experience. If fitted rightly it will never work loose and will leave keyway in shaft in proper shape and not like Fig. 1, but as it came from the factory. If the key is not fitted perfectly it will soon work loose and ruin the keyway in shaft, and then a com-

bination key like Fig. 2 has to be made, which is very hard to fit. Square steel bars should be bought,  $\frac{1}{8}$  larger than required size of key. Then saw the bars into right lengths ready for fitting and use at short notice. There should be one samson jaw each for removing armature and intermediate pinions (see Fig. 3). They are made of machinery steel with a center piece to be between end of screw and shaft, so as not to injure the center, in order that when the armature is put up in a lathe it runs true and saves time for the machinist. A long socket wrench should be made to fit hexagon head of samson screw, either with holes for levers or square on the end for a handle, so as to easily turn the screw with workman outside of the truck and plenty of room to move in. The method I employ to hold pinion and key in position, so as not to work loose, is the following:

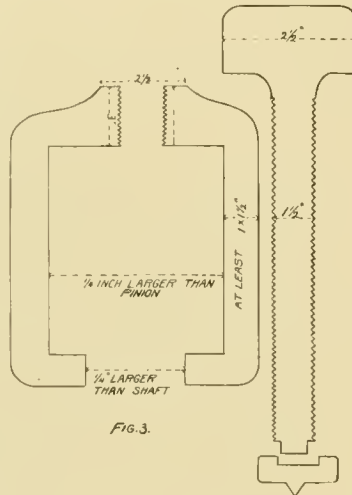

Drill a hole through the keyway, making the diameter of the hole equal to the width of the key, the inner edge of the hole being even with the outside face of pinion. Have the key also even with the pinion. Then put in a split key from the side on which the pinion key is, so as to have the head of the split pin press hard against the key. This will prevent rattle and never work loose, as collar or nut is likely to do, owing to the great jolts and jars to which trucks are subjected while a car is in service; I have never known a single instance where this has failed.

Every electric railroad car barn ought to have at least one pit equipped in the following manner: A track should be laid the full length of the pit, with a small truck on which should be mounted either a hydraulic or screw jack in such a manner that the top should fit the motor-frame, so that one man and a boy can take down as well as mount a motor quickly. A traveling crane with a two ton block and fall should be over the same pit. The crane can be cheaply home-made of old rails. All pits should be dry and healthy and in cold climate steam heated, so as to make the men comfortable. They can do more and better work. When cars have to be jacked up the quickest method is to have four blocks and falls of the improved patents hung in such a way that they can be moved quickly to any part of pit by one man. Then have skids with large iron hooks shrunk on. This method will enable the man to quickly adjust the car body to fit bolt holes of truck. The car barn should have a strong bench with vises and drawers of various sizes. The day and night men's closets and tools should be separated from each other. The kind of wrenches used

has much to do with rapid work, and my experience has been (and I have used almost every make) that the Westcott wrenches, of Homer, New York, are the best for truck and motor work. Separate boxes should be kept for old brass and scrap iron.

Brake shoe lockers can easily and cheaply be put up between the pits; also track-sweeper's tools. All lockers should be under lock and key. Oil cans and grease pots should have a special locker in the car barn. Galvanized iron is the best, with a large pan to cover the whole floor of locker so that if any oil is spilt it is saved. Colored waste is good enough for all motor work, and the economy of same should be studied, as the men often will use too much if not watched closely. One day I stepped into the car barn of a sixty car road and I found forty-five men engaged in repairing the motors, trucks and cars. On inquiry I found the majority received on an average a dollar and a half per day. Seven men were busy in mounting a motor, all in each others way, each talking and swearing. Yet this road had thirty-five cars in the shop, twenty-five on the road, and several of these with flat wheels. There was a daily pay roll of no less than eighty dollars and the road a failure. The same method is to-day followed on many roads in operation. This is a fearful mistake and speaks badly for the men in charge. Cheap labor does not pay anywhere around an electric station. Very little muscle is required, but lots of brain. The right method is to employ skilled men and pay better wages, and if the above mentioned road had employed eight good men at two and a half per day, and two boys learning the business, they would have saved about fifty dollars per day and very likely have every car in good order. Nor is this all. We must remember that when a car is in the shop it is costing money, while it is out on the road it is making money.

Train your men for specialties—one man to be responsible for trucks and brakes, one for mechanical parts of motors, one for the electrical parts, as commutators, brush holders, rocker arms, cable wires, terminals, controllers, lamp circuits, fuse boxes, lightening arresters and trolleys; each man to have his own helpers. I find that apprentice boys can be successfully used in car barns without pay for about six months. After that they receive pay according to capability. They are handy in keeping shop clean, doing wiping and lifting, and in a few years, if properly trained, they often turn out splendid pit men as well as good car electricians.

#### Only One Night Out to Florida.

The morning train via the Monon Route connects at Cincinnati with the 7:00 p. m. through Vestibuled Train, on the Queen and Crescent Route, reaching Jacksonville at 10:50 p. m. the following day. The service of this popular line is unsurpassed by any line to the South. For rates, address City Office, 232 Clark street, Chicago, or Frank J. Reed, G. P. Agt., Monon Block, Chicago.



**THE NOVEL ADVERTISEMENT OF THE SAN FRANCISCO EXAMINER.**

The bright, original and generous management of the San Francisco Examiner made gala-day for all the children of San Francisco's schools, by the ticket herewith illustrated, good for one day's unlimited enjoyment, and the Examiner paid the bill.

They all went to the Midwinter Fair. As may be seen from the illustration the ticket was equal to the freedom of the Sunset City. The coupon took the young Californian from his home free of charge to the gates of the Fair. The next trip slip admitted the youngster to the inside of the great show where the fun began. Not content with merely the general admission, the Examiner day ticket was followed by eight coupon admissions to an equal number of concessions whose managers were in sympathy with the children. Then at the top a return street car ticket to take the tired sight seer to supper and to bed came next to a souvenir card, intended to remind if necessary, that the Examiner has a big, kind, heart for all the children in Frisco.

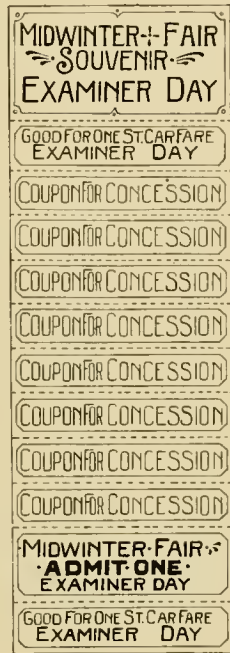

Chief of Police Crowley detailed 150 extra men to look after the infants and sort them out in case of getting lost.

Enterprising exhibitors made special effort and gave special invitations to the children to visit beef tea booths, cracker exhibits and what not, while the bands played because,—well they didn't have any work to do.

**SPEAR & SMITH TRACK SWITCH.**

This is a very simple arrangement shown in plan and elevation in the accompanying engraving. The point is

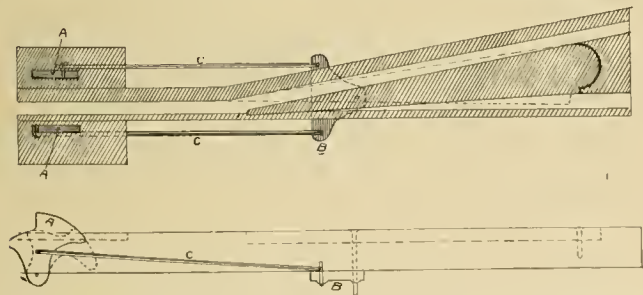

turned by having a device on the car which strikes a segment connected by rods to the three-cornered piece, under and attached to the switch point. The segments extend above the track surface, one on each side. The car attachment is turned so as to strike one or the other

of the two segments, by a handle on the front platform. The attachment being back near the truck, motion is transmitted to it by a sprocket gear. The switch is the design of Speer & Smith, 620 Holmes street, Youngstown, O.

**THE PNEUMATIC BRAKE.**

In this style of air brake, which is made by the Pneumatic Brake Company, of San Francisco, the air is compressed by a special steam driven compressor at the power house, to a pressure of 350 pounds, and is stored

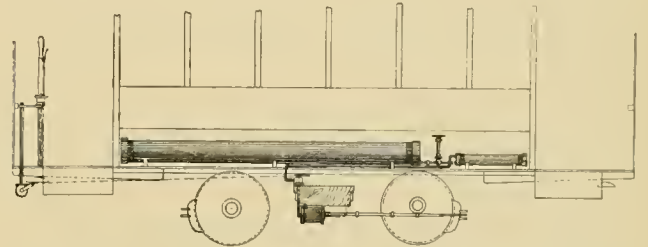

in tanks under the car seats, the intention being to have conveniently located intakes in the car house and along the tracks. It is calculated that a 300 pound charge will be good on an ordinary car for a 10-hour run.

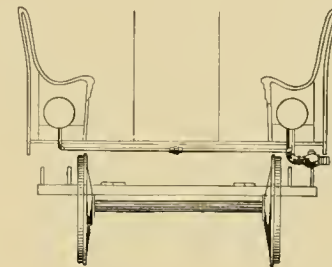

A large compressor located at the power house is said to be cheaper to operate and maintain than a pump on each car. The car has in addition to the main air storage cylinders, two auxiliary reservoirs connected through reducing valves with the main reservoirs. In one auxiliary cylinder the pressure is about 25 pounds. In the other about 35 pounds. Air is admitted to the brake cylinder from the low pressure cylinder for a service stop and from the high pressure for an emergency stop.

**Custer's Last Battlefield.**

A visit to this spot, which is now a National Cemetery, is extremely interesting. Here, seventeen years ago, General Custer and five companies of the Seventh U. S. Cavalry, numbering over 200 officers and men, were cut to pieces by the Sioux Indians and allied tribes under Sitting Bull. The battlefield, the valley of the Little Big Horn, located some forty odd miles south of Custer, Montana, a station on the Northern Pacific Railroad, can be easily reached by stage. If you will write Chas. F. Fee, St. Paul, Minnesota, inclosing four cents in postage, he will send you a handsomely illustrated 100 page book, free of charge, in which you will find a graphic account of the sad catastrophe which overtook the brave Custer and his followers in the valley of the Little Big Horn, in June, '76.



## STREET RAILWAY LAW.

EDITED BY MR. FRANK HUMBOLDT CLARK, ATTORNEY AT LAW, CHICAGO.

*Injury by Car Belonging to One Company and Driven by Employe of Another Company.*

Where a party has been injured by collision with a car belonging to one company, drawn by horses belonging to another company, and the driver is in the employ of the latter company, the action is properly brought against the latter company.

The defendants, the New York and Harlem Railroad Company, were owners of a railroad which ran through certain streets of New York City. There was an agreement between defendants and the New York and New Haven Railroad Company by which the cars of the New Haven Company were allowed to pass over defendants' track for a considerable distance in the city. A short track had been laid down in Canal street by the defendants for the use of the New Haven Company, and led from the track used by the defendants and the New Haven Company in common to the New Haven Company's depot in Canal street. The contract also provided that the defendant should furnish horses and drivers to draw the cars of the New Haven Company from the depot in Canal street to Thirty-first street.

Plaintiff was thrown out of his wagon and injured, in Canal street, by a car which belonged to the New Haven Company; but the horses which drew it and the driver who was driving it were in the employ of the defendant, the Harlem Company. The sole question which arose was whether the Harlem Company or the New Haven Company were liable.

The exact question has not arisen before in this country. It has arisen, however, in several cases in England.

The true rule is that which is stated in *Quarman v. Burnett*, 6 Mees. & Wells, 499. In that case the defendant was the owner of a carriage and had hired from a third person a driver and pair of horses to draw the same for a short time, and during this time the plaintiff's horse, through the carelessness of the driver, was injured. The question was whether the defendant, as owner of the carriage, was liable. Parke, Baron, says: "Upon the principle '*qui facit per alium facit per se*', that person is undoubtedly liable who stands in the relation of master to the wrongdoer, who has selected him from the knowledge of or belief in his skill and care, who could remove him for misconduct, and whose orders the wrongdoer, as a servant, was bound to receive and obey." It is evident that every word here said is applicable to the case before us.

The Harlem Railroad Company was the owner of the horses which drew the car, and the driver was in their employ, paid by them, bound to receive and obey their orders, and liable to be dismissed by them at pleasure.

The fact of negligence has not been in dispute at all, but we have simply to determine which of the companies is liable in damages to the plaintiff. We think the proper parties are sued in this case. The sole distinction between this and the other English cases is that the

conductor who came down in the New Haven cars might have had a supervision over the driver of the car, but it does not appear that in point of fact the conductor gave any directions in relation to these matters at all. We have, therefore, the case of the Harlem Company being the owners of the horses, and the driver being their servant and in their immediate employ. Under these circumstances it appears that the Harlem Company were alone liable.

(New York Superior Court. *Weyant v. New York & Harlem R. Co.* 1 American Street Railway Decisions, 160.

*Negligence in Running Electric Cars—Excessive Speed—Evidence—Liability of Company.*

This was an action brought by the appellee, who is a minor, by his next friend, against the appellant Company to recover damages for a personal injury. The appellant operates a street railway line, propelled by electricity, in the City of Peoria. The appellee, a boy about sixteen years old was riding with two other lads in a buggy on Adams street, when the buggy came into collision with one of the Company's cars, causing the injury complained of. The declaration charges negligence against the defendant in operating its car at an excessive rate of speed, and in failing to take notice of the buggy while on the track by reason of the shying of the frightened horse and to stop the car in time to avoid the collision.

If the average rate of speed fixed by the street railway company is excessive, in view of the stops necessary to be made in the route, the company will be responsible for an accident occurring from the fact that one of its servants was speeding a car in conformity to the schedule of the company.

Evidence of the distance of the round trip of the car and of the schedule time for making such trip is admissible in behalf of the plaintiff in connection with other testimony introduced as to the rate of speed of the car at the time of the collision.

In such cases it is for the jury, looking at all the evidence, to say whether the man in charge of the car which collided with the buggy was unnecessarily driving the car at an excessive rate of speed, or whether the company had, by its schedule, fixed such a short time for making the round trip that the motor-man was obliged to go at an excessively rapid rate in order to make all required stops and pass over the length of the line within the prescribed time.

(Supreme Court of Illinois). *Central Railway Co. vs. Allmon*, 147 Ill. 471.

*Injury to Child—Contributory Negligence—Running in front of Car—Negligence of Driver—Conflicting Evidence—Refusal to Direct Verdict for Defendant.*

The sole question for determination is whether the defendant company was guilty of negligence in the man-

ner of running its car at the time the accident occurred. This is the only question in the case, and the only one raised by the specifications of error. The learned Judge below was asked to direct the verdict for the defendant. We think this request was properly refused, as there was evidence that could not be withdrawn from the jury. It may be, as contended by the defendant, that the child ran suddenly under the car, and was not seen by the gripman, but there was evidence on the part of the plaintiff that other persons saw the child when the car was two lengths and a half away. There was also evidence that the gripman at the time was not attending to his business, that he was standing on the side of the cab, with one hand out of the window and looking towards the houses he was passing, and that he did not have hold of the grip or brake, that when called to by persons who saw the child, he paid no attention to the warning. This testimony, if true (and it has been so found by the jury) is of a very damaging character.

Judgment affirmed.

(Supreme Court of Pennsylvania). *Schnur vs. Citizens Traction Co.*, 25 Atlantic Reporter 650.

*Track Running Through Cut in Street—Excessive Speed—Injury to Horse.*

At the point where the accident occurred the defendant company had cut down the grade of the street, by the width of its tracks, some two feet. This was done in anticipation of a change of grade by the city. The dirt from this excavation was thrown upon the street upon either side of the track, and so allowed to remain for some weeks. A boy of seventeen years of age was riding a horse belonging to the plaintiff, along the right hand track, going away from the city. An electric car belonging to the defendant company was approaching on the other track. Just as the car and horse were nearly opposite each other the horse, it is alleged, became frightened and attempted to climb out of the roadway over the embankment referred to. The boy pulled him back and attempted to dismount. While he was trying, as he said, to dismount, the horse was struck by the car, and died from the effects of the collision. There was evidence that the car was going through this cut at a high rate of speed for an electric car—faster than usual. If this be so, and the jury have so found, it was gross negligence on the part of the company. Their cars should have been run slowly and with great care through a place of this description. The cut in the street and the dirt piled upon each side of the track was a work of its own creation, and for which it was responsible. It was an obstruction to public travel, and great care should have been exercised in running the cars at such a place. But for this obstruction it is not likely the accident would have occurred. The court below was entirely right in submitting the case to the jury.

(Supreme Court of Pennsylvania, *Greeley v. Federal St. R. Co.*, 25 Atlantic Reporter, 796.)

*Action Against Street Railway for Personal Injury—Evidence of Policemen Arresting Car Driver—Statements of Driver Regarding Accident.*

A policeman who arrested the driver of a car that had run against a woman was allowed to testify as to the arrest in an action against the employer of the driver for negligence. *Held*, that the evidence was inadmissible.

After the arrest, but before leaving the car, the driver, in answer to the policeman's inquiry why he did not stop the car, stated that the brakes were out of order. *Held*, to be mere hearsay, and not admissible in evidence against the driver's employer.

(New York Court of Appeals. *Luby v. Hudson River R. Co.* 1 American Street Railway Decisions 279.)

*Injury Caused by Defective Street—Judgment Against City—Action by City Against Street Railway Company.*

A city ordinance permitting a street car company to lay its tracks in a certain street required that the same be on a level with the street, and that the space between the tracks be kept in good repair. An action was brought against the city for personal injuries resulting from defects in such street. The complaint alleged that the street was full of holes, and that the rails of the street car track were some four inches above the level of the street; that by reason thereof plaintiff was thrown from his wagon and injured. The street car company was notified of the action and rendered some assistance in the defence. The jury were instructed that the city was liable, and judgment was rendered for the plaintiff. *Held*, in an action by the city against the street car company for the amount of such judgment, that the judgment was conclusive only of the facts that the street was defective, as alleged; that by reason of such defects plaintiff was injured, and the amount recovered.

It was error to reject evidence by defendant that its tracks were laid, kept and maintained in compliance with the ordinance.

The burden of proof was on the city to show that it was the fault of the street car company that the rails were above the level of the street.

(Supreme Court of Missouri. *City of St. Joseph vs. Union R. Co.* 22 Southwestern Reporter 794.)

*Street Car Colliding with Vehicle—Frightened Team—Failure to Stop Car After Knowledge of Danger.*

In an action against a street railway company which operated cars by means of steam motors, for injuries caused by colliding with plaintiff's horses and carriage, it appeared that the engineer saw plaintiff's team 150 feet away; that the moment the horses saw the engine they became frightened and showed by their actions that they could not be managed; that they plunged and backed the carriage on the track when the engine was seventy-five feet away; that plaintiff halloed and waved his hand to stop the train; and that the train could have been stopped within a space of ten feet. *Held*, that the en-

gineer could have seen the helpless condition of plaintiff in time to have stopped the train and avoided the injury.

Where the evidence clearly showed that plaintiff made every effort to avoid a collision, but, on account of the frightened condition of the horses, could not control them, the court properly refused to charge that if plaintiff could have seen the car approaching and did not escape it is presumed either that he did not look or did not heed what he saw, and that such conduct is negligence.

The fact that plaintiff could have traveled on some other street than that on which the street car track was laid is not negligence, where he had no reason to believe that his horses would become unmanageable at the sight of the engine and cars.

(Indiana Appellate Court. Muncie St. R. Co. v. Maynard. 32 Northeastern Reporter, 343.)

#### AMERICAN CAR COMPANY NEW AGENCIES

President Sutton, of the American Car Company, St. Louis, is a whole force of traveling men in one, but the varied and extensive interests of the company require his presence in so many places at once, he has gone into the field this year with additional and exceptionally valuable aides, and has secured Mr. Andrews, who leaves the J. G. Brill Company, and Mr. Lawless, another as widely known street car man.

The history of supply business in Chicago turns over a March leaf and chronicles the change of Payson K. Andrews, for the past three years the western agent for the Brill Car Company, to the Chicago office of the American Car Company of St. Louis.

Ever since 1882, Mr. Andrews has been a familiar figure at the street railway conventions. Boston was his first one '82, when Mr. H. H. Littell was president.

Mr. Andrews is about forty years of age and a son of Massachusetts. He was educated under the shadow of Andover theological seminary, at Andover academy. His father was a steam car builder, so that the son naturally became interested in the same line of work. His first connection was with steam car building, also serving an apprenticeship of three years on steam engine building. He afterwards became associated with his brother in the manufacture of car wheels and car springs, going on the road and visiting both steam and street railways. In this capacity he remained, until in 1890 he became a salesman for the J. G. Brill Company. A year later he was made western manager, with offices at Chicago, which position he now leaves to accept the attractive offer of the American Car Company of St. Louis. With headquarters in Chicago, Mr. Andrews has been very successful, having sold in a single year street cars to the value of over \$350,000.



PAYSON K. ANDREWS.

E. J. Lawless of the New York office, was a cable road pioneer, having had a part in the construction of the Sutter street cable railway of San Francisco, in 1878, the first street cable road in the world. When the line was completed, Mr. Lawless says that he was "appointed assistant superintendent, assistant secretary, assistant splicer, emergency conductor and gripman, all of which positions were filled when occasion demanded." In 1885 he was made superintendent of the Kansas City cable road. In 1886 he became general superintendent of the Metropolitan Street Railway of Kansas City, remaining with it until the completion of cable construction by that company in 1888. From then until 1891 he was engaged in pursuits outside of street railway work. In the latter year he assumed the management of the Paterson, (N. J.) Railway Company, and after completing the change from horses to electricity, resigned and went to New York in 1893. It will be seen from this brief sketch that Mr. Lawless was always on hand and in demand during the most trying period of each road's existence, which tells his practical value better than words, and his friends will not be disappointed in the record he will make with the American Car Company.

#### A NEW STYLE OF TENSION WAY.

The object of this form of cable driving machinery is to do away with the space necessary for the ordinary tension way. It is the design of William H. Robinson, mechanical engineer, 1223 West Norris street, Philadelphia. The plan is to have an idler pulley underneath the driving pulley. The idler is placed in vertical ways, so that it can slide up and down. The weight of the idler regulates the tension of the cable, but this can be varied with the

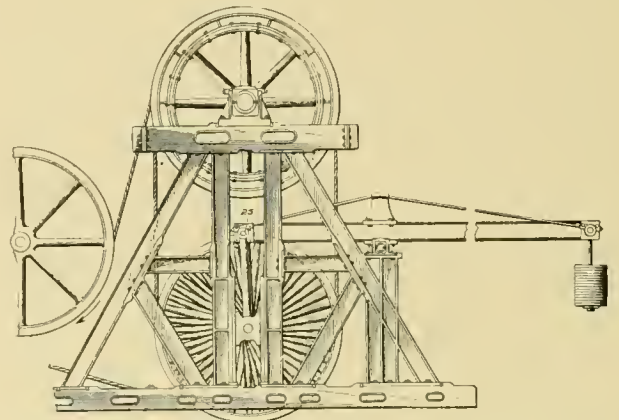

counterweight shown. The idler consists of a number of independent sheaves, each being free to turn independent of the others. It is evident however that the driving drum must have differential rings, or the cable will be obliged to slip on the driving drum when the idler rises or falls. The tension carriage on many cable lines is called on to take up from 8 to 15 feet of slack rope instantly, which without the rings on the driver it would seem impossible for our illustrated device to do.

## THE HARTHAN TOWER WAGONS.

The tower wagons of this make are collapsed in rather a peculiar way, by being let down over the rear end, as shown in the illustration. The towers are made detachable from the wagons, to which they are held by only four

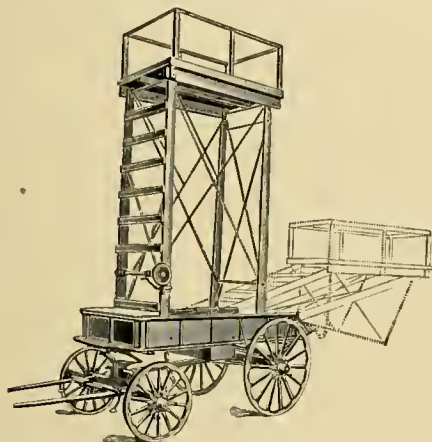

bolts. The wagon and tower complete weigh about 1,200 pounds, the intention being to make a wagon easily handled by one horse. The tower is elevated by a crank and can be set at any height between maximum and minimum. S. E. Harthan, of Worcester, Mass., is the maker.

## MAINTENANCE OF ROLLING STOCK.

III.

The interest aroused by the investigation of the REVIEW into the matter of motor maintenance is not to be wondered at, since the cost of maintenance on many roads exceeds the total cost of power, and instances are still more numerous where this item exceeds the fuel bill. A great deal of study has been put on the question of fuel reduction, and the question of repairs ought to receive the same study.

THE EAST HARRISBURG PASSENGER RAILWAY has 43 double motor cars, as follows: 9 sixteen-foot equipped with F-30 motors, 4 twenty-five-foot cars with S. R. G's, 9 twenty-five-foot cars with W. P.-50's, 1 twenty-five-foot car with G. E.-800, 20 sixteen-foot with S. R. G's. The whole equipment averages about two years of age. Twenty-five cars are used every day. The repair force at the barns consists of eleven day and four night men. The night men inspect each car every night. A peculiarity of the system used in this barn is that each man is held responsible for the condition of some particular part or parts. Thus one man is responsible for trolleys, another for brakes, and so on. All motors are cleaned every night by the motormen. Winding and all repairs necessary are done in the shop except refitting car wheels. The principal troubles are from grounding of armatures and rheostats on the F-30 motors and grounded commutators on the W. P.'s. Motors are overhauled once a month. The pay roll is \$18.50 per day.

## SANDUSKY STREET RAILWAY.

This road is equipped entirely with single motor cars, having 10 double reduction and 4 single reduction Westinghouse motors, the majority of which have been running three years. Nine cars are required for the regular service. Two night men do the inspection and cleaning and are assisted by an armature winder, a carpenter and a blacksmith working during the day. One of the night men does nothing but inspection and repair work and the other cleans the cars and does the oiling. The motors are overhauled about every three months. Gears and commutators on the double reduction equipments give the most trouble. The cost of labor in this department is about .75 cents per car mile. Two single reduction motors have been running for three years without burning out an armature or field coil.

## JANESVILLE STREET RAILWAY.

Superintendent A. H. Johnson reports an equipment of eleven cars with two Sprague motors each, nine of which are in daily use. They are taken care of by three day men and two night men. The force consists of an electrician, winder, blacksmith, car inspector and general workman. Cars are inspected three times a day. The only repairs undertaken are rewinding armatures. The commutators give the most trouble. In three years only five armatures have been completely rewound. The pay roll is \$7.56 per day.

## STRIKE AT LONG ISLAND CITY.

Long Island City, L. I., was in a sad plight March 16, when all the employes of the Steinway lines went out on a strike and emphasized their remarks by cutting and grounding the trolley wire, piling stones on the track and dangerously injuring Road Inspector Cosgrove with a sharp stone which hit him in the head. The men say that the superintendent only gives them 80 cents a day and that by the discharge of eighteen men he means to break up a K. of L. assembly. The superintendent claims that the men may earn \$2.00 a day if they will. Peace was restored by both sides agreeing to the arbitration of Mayor Sanford and the men helped to repair damages. The travel was so delayed that thousands of persons who do business in the various towns led into by the Steinway lines, were forced to walk many miles. The New York Advertiser says:

"Where was ex-Mayor Gleason, when the strikers were cutting trolley wires, breaking up cars and shooting officers between Steinway and Gooseygoatville - on - the - Stench? Then was the time when he should have appeared with battle-ax and pike, fist, bludgeon and the rest of his armory, in protection of his propertee and the main-tain-ance of lar and ardor. We never miss the water till the well runs dry, and it's "Oh! for an hour of Paddy" when Paddy isn't nigh.

THE Sandusky Street Railway rents its power from the electric light company at \$1.75 per car per day of 18 hours. The railway owns the generators and keeps them in repair.

## MISSED A CAR.



IT WAS a wild night without and the pattering rain mixed with sleet made all nature miserable, says the Philadelphia Press. The clock had just tolled the hour past midnight when the physician was aroused by the ringing of his door-bell. He jumped out of bed, put on his dressing gown, went to the window, raised the sash, and saw a man muffled to the ears standing on his front step. He asked:

"What do you want at this late hour?"

"I am Mr. Carr," was the answer.

"Well, go home. I am not responsible if you did miss a car. Why did you stay out so late?"

The window went down with a bang and the doctor went back to bed.

The bell rang again, the doctor put his head out of the window and saw the same man on the step.

"Doctor, doctor! I'm Mr. Carr."

"Well, if you did miss your car, what have I got to do with it?"

"C-a-r-r, doctor, C-a-r-r. Don't you understand?"

"What do you take me for, a conductor?"

"No, no, doctor. Mrs. Carr, my wife, your patient, is very ill and requires your services."

"Oh, that's you. Carr, is it? Why didn't you say so before?"

## ASPHALT PAVING TO T RAIL.

By W. H. Smith, Electrician and Superintendent of Machinery, Ogden City Street Railway.

Street railway companies of late have been wrestling with the problem of street paving. The first thing that arises is the expense, and how it can be done the best and cheapest. Quite a number of experiments have been made with the different paving materials, and with the different styles and shapes of rails. A set rule will not hold good for every city. The condition of the founda-

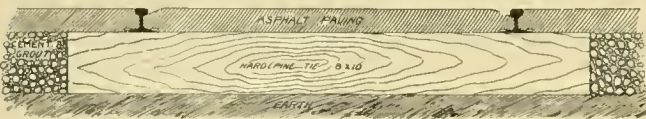

tion, locality, traffic, etc., must be considered. A rule that will apply in one city will not hold good in another city or town.

I will submit to my fellow-sufferers a brief description and cross-section of track and paving put down in September, 1893. Three blocks of 750 feet each were laid on Twenty-fifth street leading from the Union depot. This is one of the most frequented streets in our city.

The street was graded down and thoroughly rolled with a ten-ton steam roller, and the ties were laid on the ground 14 inches between centers and surfaced up to grade. We used 30-pound T rail spiked to the ties, in the ordinary way. The rails were thoroughly bonded

with cross bonds connected to a number 4 soft copper return wire. All joints were soldered. The return wire was laid on top of the ties to keep it from the moisture, and securely fastened to the ties with staples. Crushed rock and cement were tamped in between the ties, flush with the top, and two coats of asphalt laid on top. On the outside of the rail the asphalt comes flush with the top. On the inside a groove or channel is left for the flange of the wheel. The curve at the corner of Twenty-fifth street and Wall avenue was put in as the above, with the exception that cinders were tamped under the ties. After five months' hard usage we find on a close examination that a few of the joints where cinders were not used have gone down a trifle and the paving is working loose, but on the curve where cinders were used for surfacing and between the joints the track is as good and true to surface and gauge as the day it was put in.

Our experience in paving leads us to believe that in a small city of ten or fifteen thousand, paving can be done with moderate expense in the above way, if particular attention is given to getting a good solid foundation for the ties, and by using cinders (we prefer cinders to anything else) to tamp under the ties, a road can be paved in this way that will give good results both to the railway company and the city.

## STEEL BONDING CAPS.

The accompanying cut shows views of the new track bonding device recently brought out by the Ohio Brass Company, of Mansfield, Ohio, and consists of a steel cap which fits snugly over the end of the bonding wire and into the web or flange of the rail. With this method of bonding the end of the wire is passed through the hole in the rail which is drilled  $\frac{1}{32}$  of an inch smaller than the outside diameter of the cap. The cap is then placed on the bonding wire and entered into the rail.

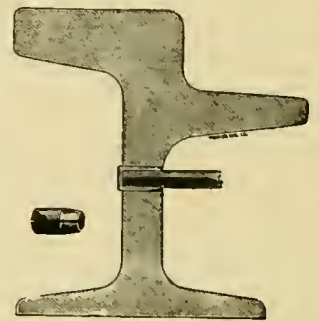

A few blows from a hammer fasten it in place. The crimp extending the full length of the cap allows the shell to compress firmly over the wire and into the rail, making a perfect air and moisture proof joint.

It can be used equally well with iron or copper wires of different sizes. The facility and quickness of bonding combined with the low selling price will no doubt bring it into speedy favor with the trade.

THE W. S. Knott Company of Minneapolis, has the order for four 62-inch three-ply belts, for the Cincinnati Street Railway. They have a couple of 73-inch belts in the twin city plants at Minneapolis.

THE FAIR FREEZER FROZEN OUT.

She was seated in the street car,  
 And the passengers had to frown,  
 For 'twas blowing cold as thunder  
 When she let the window down.

The people shook and shivered,  
 Pulled their collars 'round their ears,  
 While she sat there unmolested  
 In a fine, new set of furs.

She was asked to "close the window,"  
 But she merely waved her arm.  
 "No, gentlemen, excuse me,  
 For I'm comfortably warm."

Then the men, as mad as blazes,  
 Rose en masse, "just then an' thar,"  
 And they let down every window  
 That would open in the car.

And the woman in the sealskin  
 Got a blossom on her nose,  
 She began to shake and shiver  
 Till her face was nearly froze

The passengers enjoyed it,  
 And she soon was looking sad,  
 For it was the first new sealskin  
 That the woman ever had.

And she was out to show it,  
 As she took in winter's breath  
 By a great big open window,  
 Freezing other folks to death.

But she jerked the strap directly  
 And she, shivering, left the car,  
 And they laughed to hear her mutter,  
 "What a naughty set you are!"

Then they hoisted all the windows  
 And in comfort gave a shout,  
 For instead of being frozen  
 They had friz the freezer out.  
 —Will Essays in Waterways Journal.

THE WHITE-CROSBY COMPANY.

On May 1 the well known firm of J. G. White & Company, contractors, of New York, will be joined by O. T. Crosby, and the name will become the White-Crosby Company. The headquarters will be moved to Baltimore. The reasons for the change of location are, cheaper rents, good markets, plenty of storage room, and the fact that the large amount of work contracted for in Baltimore at present would require offices there for a year or more. Of the new company, O. T. Crosby will be president; J. G. White, vice-president; and G. H. Walbridge, secretary and treasurer. Mr. Crosby, who needs no introduction, was born in Louisiana, and graduated from the United States Military Academy at Brookhaven, Miss., in 1878. He served as an officer in different engineering corps until 1887 when he joined the Sprague Railway and Motor Company, soon becoming superintendent. After two and one-half years with this concern he became connected with the Weems high speed experiments which attracted so much attention. He then identified himself with the Thomson-Houston staff, and recently has had charge of the railway department of the General Electric.

J. G. White graduated from Pennsylvania State Col-

lege in 1882 and from the electrical engineering course of Cornell University in 1885, holding a fellowship the last year. For the two years following he had charge of the department of physics in Nebraska University, when in 1887 he organized the Western Engineering Company, which did considerable western construction work, until in 1890, it was sold to the United Edison Company. In the same year Mr. White resigned and formed "J. G. White & Company."

The New York office will be left in charge of A. G. Greenburg, a graduate of Princeton, who has had experience in electrical matters with the Thomson-Houston, Ft. Wayne, and Washburn & Moen Companies. J. F. Easterbrook, a Yale graduate, and formerly assistant engineer in the Chicago office of the Edison Company has charge of the Chicago office. Altogether the combination throughout is an eminently strong and practical one, and continued success is assured in a measure commensurate with the increased capacity to plan and execute.

AMES DIRECT CONNECTED ENGINE.

The engraving herewith presented, represents an Ames high speed engine directly connected with a general electric multipolar generator, making an entirely self-contained plant. The engine is 13 by 12 and makes 275 revolutions per minute. The generator is 50-kilowatts. The floor space occupied is 7 feet, 6 inches by 9 feet, 4 inches. Two of these combinations have been put in the Continental Fire Insurance building, New York.

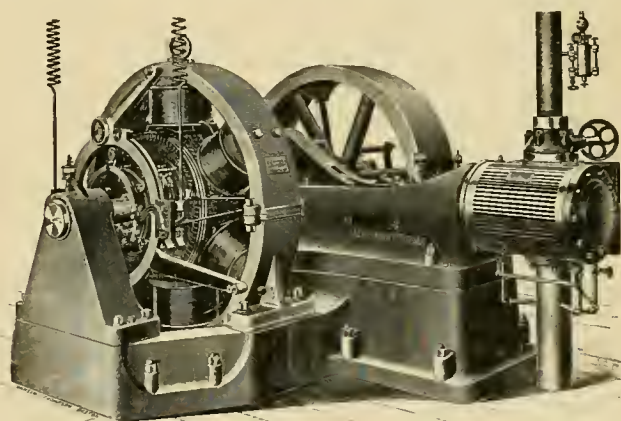

The advantages of this form for condensed plants are clearly evident. The Ames people insist on furnishing an outer bearing or pedestal to support the end of the engine shaft. It is very substantial and fitted with a ring oiling device similar to those on the main engine bearings. They believe that any arrangement whereby the armature is hung on the extended shaft without this bearing to be poor engineering and necessarily unsatisfactory. The Ames engines both simple and compound are well adapted to direct connection with any make of generator.

THE Chicago Lake Street "L" has been finished through to West Fifty-second street, five and a half miles from the heart of the city.

## RELATIVE COST OF STEAM, COMPRESSED AIR AND ELECTRICITY FOR THE OPERATION OF RAILROADS.

BY GENERAL HERMAN HAUPT, CONSULTING ENGINEER.

There seems to be a general misapprehension in regard to the relative economy of electricity as a motive power for the propulsion of cars upon surface and elevated railroads, as compared with steam and compressed air. It has been proposed to use electricity for the operation of elevated railroads in Chicago and New York, and it was also proposed for an underground system for the latter city.

Electricity has apparently been applied with success to the operation of street railways, hauling one or two small cars; but the cost of equipping a railroad for hauling heavy trains long distances with stations at short intervals, as compared with steam or compressed air, becomes excessive, and the cost of operation is much greater than with compressed air.

The idea is generally entertained that heavy grades are more easily overcome by electricity, but a moment's reflection ought to satisfy any one that this is a fallacy, for it requires a fixed amount of power to overcome a given resistance, whatever motive power is used.

Having been called upon recently to examine and report upon the relative cost of plants, and of operation, for the new lines of elevated railroad proposed to be constructed in New York, the writer sought an introduction to the officers of the General Electric Company, by whom he was courteously received, and who very kindly furnished all the data required for electrical installation.

The problem submitted to them was: "Given a double track elevated railroad, twenty miles long, with trains similar to present elevated trains, running at one-minute intervals, and twenty miles per hour, or two hours for a round trip; how many power stations would be required for the operation of the line, where should the stations be located with reference to the terminals, what power would be required at stations, and what the cost in detail of the installation?"

The answers, which were based on the actual experience and results of the Intramural railroad at the World's Fair, were as follows: The cars had two 4-wheeled trucks and a 150-horse-power electric motor was attached to each axle, making 600-horse-power for each electric motive power car, costing for each car so fitted, \$10,000. The trains were made up of one such car and three trailers; and it was stated that the same power would be required to operate the elevated railroad trains. It was also stated that the horse-power at the motors would be less than that at the power stations by 35 per cent, the loss being

From steam engines to generators.....	10 per cent.
Transmission along conductors.....	10 "
From conductors to car motors.....	15 "

As there would be 120 trains on the road at a time, there would probably be 100 using current at once, the balance making stops at stations, and if each train requires 600-horse-power, there would have to be supplied at the motors 60,000 horse-power; and allowing for the losses of 35 per cent, the steam engines at the power house would have to develop over 92,000 horse-power. The cost of installation at the power houses was given as \$50 per horse-power, made up as follows:

Steam engines .....	\$20.00
Generators or dynamos.....	20.00
Boilers .....	17.00
Piping .....	3.00
Buildings.....	10.00
Real estate and incidentals.....	10.00
Total,	\$80.00

Chas. H. Davis, in his hand book of tables for electrical engineers, gives the cost per horse-power at \$50 without buildings and real estate, which would increase the above to \$100, but \$50 was taken as the basis of the estimate.

The power stations were to be two in number, located each five miles from the terminals, so that the current would not have to be transmitted to a greater distance than five miles, the loss being proportional to the distance. The conductors recommended were old iron, or steel rails, as being more economical than copper of equal conductivity. Six lines of these rails being required in the first mile from the power stations in both directions.

It is estimated that the cost of installation, based on the above data, would be as follows:

Rails for conductors.....	\$250,000
Laying, insulating, and copper connections.....	150,000
Outfit for 120 motors, at \$10,000 each.....	1,200,000
92,000 horse-power at power houses, \$80 each.....	7,360,000
Total,	\$8,960,000

The writer's original estimate gave the amount as \$9,600,000, but upon reflection it did not seem as if sufficient allowance was made for trains stopping at stations and during that brief interval using no current. He now thinks 20 trains out of 120 a fair allowance. As compared with steam and compressed air plant to perform the same service, the cost would be: 120 steam locomotives at \$5,000 each, \$600,000; 120 compressed air motors and compressor plant, \$1,800,000. The compressor plant is taken at manufacturers' estimates, and what they are willing to guarantee.

It may be noted that 120 motors would not be sufficient for such a service, as there are always a number of engines in relays, in reserve, and undergoing repairs; but as electric motors cost double what steam and compressed air engines do, the comparison would be still more unfavorable to electricity if the number was increased.

The relative cost of fuel for operating is computable as follows:

Elevated steam locomotives consume about 40 pounds of anthracite coal per train mile, costing, say, \$6 per ton in Chicago and \$4 per ton in New York.

Stationery engines for generating electricity or compressing air, consume about 2½ pounds of bituminous coal per horse-power per hour, costing, say, \$3 per ton in Chicago and \$2.50 per ton in New York.

The compressed air locomotive tested on the New York Elevated Railroad in 1881, used 1,470 cubic feet of free air per train mile, which was stored in the motor reservoirs at 600 pounds pressure per square inch. The total quantity of



air stored before beginning the trip was 18,400 cubic feet of free air, the reservoir capacity being 460 cubic feet and the pressure 40 atmospheres.

The builders of air compressing machinery are ready to contract for power plants to do this work, and will guarantee that the consumption of fuel shall not exceed a rate of 20 pounds of bituminous coal per 1,470 cubic feet, compressed to 600 pounds per square inch. This is the equivalent of 20 pounds of coal per train mile for compressing the air. In addition to this it requires between 4 and 5 pounds of anthracite coal per train mile to reheat the air as it is used on the motors.

In a round trip of two hours, 120 trains will have covered 4,800 miles; and we shall compare the cost of fuel in performing this amount of work by the different systems.

Electricity—92,000 horse-power for 2 hours at 2½ lbs. per h. p per hour.....230 tons

Steam—4,800 miles, at 40 lbs. per mile.....96 tons

Compressed air—4,800 miles, at { 20 lbs. bituminous coal.....48 tons  
5 lbs. anthracite coal.....12 tons

At a cost of

Electricity, 230 tons.....at { \$3 00 = \$690.00 in Chicago  
2.50 = 575.00 in New York

Steam, 96 tons.....at { 6 00 = 576 00 in Chicago  
4 00 = 384.00 in New York

Compressed air... { 48 tons at \$3 00 = \$144.00 } = \$216 00 in Chicago  
12 tons at 6 00 = 72.00

Compressed air... { 48 tons at 2.50 = 120.00 } = 168.00 in New York  
12 tons at 4.00 = 48 00

The writer was much surprised at the result, for although he expected to find that electricity was much more costly than steam or compressed air, from previous investigations, he was not prepared for such a difference; and after reflection he began to doubt the correctness of the figures furnished. It does not seem that it should require 600 horse-power to move an elevated train, although he is positive the statement was made by the officials of the General Electric Company. The steam locomotives of the Manhattan Railway weigh about 48,000 pounds, the cylinders are 12 by 16 and the drivers 42 inches diameter. As the steam pressure carried does not exceed 140 pounds per square inch, the horse-power probably does not exceed 250, but he is also aware that these engines are worked to their full capacity in moving trains from station to station. It is not a case of urging the trains into speed and then running at an even pace, but a case of continual acceleration until the next station is reached, and this is frequently carried so far that the brake valve is opened before the throttle is closed, to avail of even the short interval between opening the valve and the brakes taking effect to accelerate the speed and gain time.\* Profiting by the experience of the Manhattan Company, Chicago and other places have built heavier structures, which admits the use of heavier engines; those on the Lake Street Railroad, for instance, weighing as much as 60,000 pounds. It is safe to say, therefore, that 300 horse-power per train would be a fair allowance, although the writer cannot understand why there should have been 600 horse-power on the Intramural Railroad, unless it is that an electric motor works best when not taxed to its full capacity, or unless 600 horse-power at the electric motor only means 300 horse-power at the rail. This seems likely, as an excess of power would slip the wheels.

After a discussion of the subject with the editor of one of the technical magazines, who also doubted the accuracy of the figures, they were submitted to a prominent electrician of the General Electric Company for revision. That gentleman reported that the estimate was excessive, inasmuch as it had been based on maximum instead of average resistances. He

returned a revised estimate, based on average resistances, with an allowance of 9 per cent for fluctuations, which gave 42,000 horse-power as all that was necessary at the power stations, and \$6,000,000 as the total cost of installation. As 42,000 horse-power at \$50 per horse-power is only \$3,600,000, the writer rather underestimated the cost of conductors, laying, etc.

After deducting 35 per cent for losses, there will only be 27,300 horse-power available at the motors, or say an average of 273 horse-power per train using current at once. It is difficult to understand how the maximum power can be 600, the average 273 and the fluctuation 9 per cent; but accepting the revised estimate of 42,000 horse-power, and six millions as the cost of installation, it will be seen that the latter is still many times greater than for steam or compressed air.

The relative cost of fuel for operating in two hours as revised would be:

	In Chicago.	In New York.
Electricity (105 tons)	\$315.00	\$262.50
Steam	576.00	384.00
Compressed air	216.00	168.00

The fuel used for operating the Intramural road was oil, and the writer is credibly informed that the average consumption during the six months of the Exposition was at the rate of an equivalent of 50 pounds of coal per train mile. This would give 120 tons for 4,800 miles, which is rather more than above.

The interest on the cost of installation is another item of the operating expenses affected, and ought to be considered in conjunction with the cost of fuel. It is for two hours at 6 per cent as follows, based on the supposition that the road is operated twenty-four hours per day:

Electricity	\$6,000,000	Int. \$82.20	for two hours
Steam	600,000	Int. 8.22	for two hours
Compressed air	1,800,000	Int. 24.66	for two hours

Making the combined expense for fuel and interest

	In Chicago.	In New York.
Electricity	\$397.20	\$344.75
Steam	584.22	392.22
Compressed air	240.66	192.66

Compressed air cannot be considered as an experiment, although the evidence that comes of long continued use is wanting. The writer and others can testify to the admirable results obtained from the street motor trials in New York. They answered every requirement of the service, proved to be economical, and no valid objection was ever raised against them. They could and did carry storage of air sufficient for trips of ten miles, so that trips of eight miles were well within their capacity. The capacity of the reservoirs was equivalent to 4,266 cubic feet of free air, and they used 290 cubic feet, equal to 22 pounds weight of air per mile on an average. The Mekarski system is in successful operation in France, although they use over 24 pounds of air per mile,\* and are clumsy in general design and appearance.

In 1881, a compressed air locomotive was designed by Robt. Hardie, and constructed at the Baldwin Locomotive Works, Philadelphia, under his supervision. It was tested the same year on the Manhattan Elevated Railway, with marvelous results. The tests were witnessed by a number of the officers of the road and others, who were enthusiastic in its praise, and some of whom gave written certificates of the performance. They are as follows:

John A. Wallace, engineer, who operated the engine on the trial trips.

E. B. Wetmore, who was train master when the trials were made. He has since been superintendent and master mech-

\*The Eames vacuum brake is used on these trains.

anic of the Suburban Elevated, New York, and of the Chicago & South Side Rapid Transit Company.

Wm. S. Hughes, who was foreman of repair shops on the Manhattan, when the trials were made, and who is now master mechanic of a division of the New York and New England Railroad, at Providence, R. I.

Col. R. I. Sloan, formerly chief engineer of the Manhattan. Since chief engineer of the Chicago & South Side Rapid Transit, and now chief engineer of the Lake Street Elevated Railroad.

Chas. T. Parry, of the firm of Burnham, Parry, Williams & Company, Baldwin Locomotive Works, Philadelphia, and others.

Too much space would be required to publish these certificates in full, but they all express appreciation and approval in strong terms. The question is naturally asked why was the system not adopted if the tests were so satisfactory and there were no neutralising disadvantages.

It may be said briefly that the main causes of its abandonment were bad management, incapacity and lack of financial ability on one hand, and prejudice, incredulity and indifference on the other.

The company organized to develop the system was composed of men who had no financial standing, and were incapable of surmounting the usual obstacles which all pioneers have to meet. The principal of these objections was the fear that damages from scaring horses would be heavy, which has since proved to be groundless. The company had not the financial ability to equip and operate the first line of road and no railroad company would adopt it without such a demonstration, although a magnificent success mechanically.

The Elevated Railroad Company not only declined to introduce it on their road, but the management declined even to give a statement of facts as to its operation on the road. It was strongly suspected that the reason for this was the fear that publicity given to such an official statement would bring the pressure of popular demand for its adaption, involving the expense of re-equipping the road with motive power; though a change would obviously be a public benefit; besides effecting a great saving in the operating expenses. Of the latter fact, however, the management is still ignorant. It is a fact, strange as it may seem, that no official test or investigation was ever made to ascertain the cost of operation, which fact implies that no such information was wanted. There is no lack of testimony, however, to show that the experimental engine fulfilled all the conditions and answered all the requirements of the tests so far as they went; in hauling trains over the road on schedule time; in making all the regular station stops to pick up and set down passengers; in ease of handling and smoothness of operation, and in freedom from noise of exhaust, gas, cinders, &c., as well as the fact that the car brake equipment was operated from the engine as usual; that the length, breadth and height were the same as the steam engines, that weight was from 6,000 to 8,000 pounds less than the steam locomotives recently built for the same road; that they can be recharged as quickly as the steam locomotives take water; that the cost of fuel for operation is less than 50 per cent of that of the steam locomotives; and that there never was any fault found or objections raised against it whatever. All these facts can be proved to the satisfaction of anyone caring to investigate. It is safe to conclude, therefore that the only difficulty was the one stated above.

\*A pamphlet recently published by the American Mekarski Company states that on one of the roads operated, 1,985,000 pounds of air was used to operate 82,250 miles, which gave  $\frac{1,985,000}{82,250} = 22\frac{1}{2}$  pounds per mile." This was an error of division.

The recent report of the railroad commissioners of Massachusetts, presented February 7, 1894, in referring to the trolley system, states that during the year there has been "an increase of 214 miles of electric road" and "over \$25,000,000 of capital invested." The report also says "It can and should be said without hesitation, or qualification, that the electric system has not shown or indicated any such margin of profit as to justify the expectation of more than ordinary and moderate returns on money legitimately invested in it. The idea which seems to have obtained some currency that the electric railway system is a bonanza of rare and inexhaustible wealth, is clearly a delusion, and has doubtless proved to some a snare. The absolute cost and expensiveness of the system, under the most conservative, able and honest management are sufficient to tax its earning capacity to its full limit. There is no margin for inflated or fictitious capitalization. It presents no safe or inviting field for speculative enterprise or manipulation, unless it be to the unscrupulous operators of an inside ring, who are willing to practice on the credulity of a misinformed public. Whenever there is reason to believe that water has been, or is about to be injected into the stock or bonds of an electric railway company, the only safe course is to let its securities severely alone."

In a recent letter from the electrical editor of a standard technical magazine, it is conceded that electricity cannot compete with compressed air for street motor purposes; that the storage battery is an ignis fatuus, and that expenditures in this direction will probably be discontinued; and that long interurban lines like those projected between New York and Philadelphia, St. Louis and Chicago, and Baltimore and Washington, are wild and visionary schemes.

Where steam can be used directly in a motor, electricity generated by steam cannot be employed economically for car propulsion. This is not so with compressed air, as the reheating on the motor almost wholly restores the losses by compression and transmission. The great field for electricity is electric lighting, and perhaps electric heating. It may also be advantageously used for transmitting power long distances from water falls, although compressed air may here again be a successful competitor; but for the propulsion of cars and trains on railroads, it must eventually give way to compressed air.

Gas motors have exploded and burned up. Cable lines can only be operated on long lines of straight track with advantage, and then only when there is a "magnificent business." Steam is intolerable, carbonic acid gas and ammonia are impracticable, and life is too short to wait for horses. It would seem, therefore, as if compressed air, which is growing in popular favor, remains head and shoulders above all its competitors; and the writer ventures the prediction that in a few years it will be in universal use for the operation of street railways. Why it has lain beneath and so near the surface so long, is past the writer's comprehension.

WASHINGTON, D. C., March 23, 1894.

THE Lake Street L and the South Side L, Chicago, have reached a traffic agreement, by the terms of which the South Side Company will allow the west side passengers to be hauled as far south as Congress street and the West Side Company will allow south side traffic to be carried to the corner of Lake street and Fifth avenue. The consummation of the compact, of course, cannot be reached until the proposed extensions up Wabash avenue and east on Lake street have been built.

## RELATIVE COST OF STEAM AND ELECTRICITY FOR THE OPERATION OF RAILWAYS.

By W. E. Baker, General Manager, Columbian Intramural Railway,

Having been shown the preceding article, in which the relative merits of compressed air, steam and electricity for elevated railroads are discussed, I gladly avail myself of the opportunity to reply.

While this article bears evidence of having been prepared with great care, there is in it the assumption of a condition in regard to the rate of speed which, in the absence of an explanation, is misleading and leads to manifest error in the conclusions drawn.

As a result of practical experience with the only elevated electric railway operated on a large scale, I beg to submit the following, which I trust will be of interest to your readers:

In the article referred to, while the writer does not himself take the position that he is fully cognizant of all the facts connected with the operation of an electric elevated road, the unfairness of the comparison from which his deductions are made, becomes apparent when the problem thus submitted is carefully examined, and particularly the clause referring to the speed of the train, which is to be 20 miles an hour.

The writer then proceeds to compare the cost of operating an electric road with trains making an average speed of 20 miles an hour with the cost of operating a steam road under present conditions, where the average speed is about 12 miles an hour, slightly less than this in New York and slightly more in Chicago, the stations in New York being about 1,725 feet apart and in Chicago about 2,000 feet, and it is plainly unfair to make the comparison on this basis. The comparison should be made either on the basis of 20 or 12 miles per hour under the different methods of operation. As all the elevated roads which have been operated, or are now being operated, including both the steam and electric roads, have been operated at an average speed of about 12 miles an hour, it would seem better to make the comparison on this basis, as, if we attempt to compare the operation of roads at the speed of 20 miles an hour, we must assume the conditions for both cases.

As a matter of fact it is practically, and at any rate commercially, impossible to operate an elevated road with trains of five cars and stations about one-third of a mile apart at an average speed of 20 miles per hour, especially with the present conditions and limitations of brake mechanism, as a very short calculation will suffice to show. At a speed of 12 miles per hour, and with stations one-third of a mile apart, it would be necessary to make three stops in a mile, averaging 17 seconds. This would leave for the three runs to be made in a mile 249 seconds, or an average of 83 seconds for each run, 30 seconds of which would be used in retardation; leaving 53 seconds only in which to make the acceleration from a state of rest to a speed of about 25 miles per hour. At 20 miles per hour or 180 seconds to the mile, and with three stops, we have 129 seconds in which to make the three runs, or 43 seconds to each run. If we allow, as above, 30 seconds only in which to make the retardation, which is not enough, as we will have to retard from a much higher maximum speed, still we have only 13 seconds left in which to accelerate to a speed of, say 40 miles per hour, and this is plainly impossible, although the electric operation of trains will approximate this much nearer than steam has ever been able to do,

The attempt (in the article referred to) to make the comparison between steam trains operating at the rate of 12 miles per hour and electric trains at 20 miles per hour, is the basis of the errors throughout the article. A calculation, which it is not necessary to enter into, will show that to make an approximation to the average speed of 20 miles an hour 600 horse power will be found not sufficient to do the work; notwithstanding the author of the article under consideration expresses surprise that this amount of energy should be required to operate an electric train at a speed of 20 miles per hour. When the speed of an electric train is reduced to that assumed for the steam train, 300 horse power will be found abundantly sufficient. The horse power of motors, for the purpose of comparison, should therefore be taken at 300 instead of 600, which will reduce the cost of the motor outfits to \$6,000 each instead of \$10,000.

Actual experience of the Intramural road, based on twelve days' accurate readings and forty-six separate observations, shows that the average horse power consumed per train was 42 horse power. As the stations on this road were only 1,590 feet apart, as compared with the distances of 1,725 feet and 2,000 feet above referred to; and as the road was further complicated by 25 per cent of curvature, which necessitated cutting down the speed of the trains in many cases after they had expended the power necessary to reach the maximum speed; and as the average speed under these conditions on the Intramural road of a round trip of six and one-fourth miles was 10 miles per hour, the horse power used there per train would be quite a sufficient amount for a speed of from one to two miles an hour more with stations farther apart and with straight track. The accelerations secured on the Intramural road were superior to those obtained on any elevated road now being operated by steam; and it is no doubt true that no locomotives at present being operated on elevated roads, and light enough to have been used safely on the Intramural structure, could have made the speed on that road which was made by the motor cars.

Therefore, instead of assuming that it will require 600 horse power to a train in the station, it is true only if the trains are to make 20 miles per hour, and not true as a basis of comparison. We know on the basis of the facts secured in actual practice, 50 horse power average per train is sufficient; but to allow for the extra car in the train and for surplus power, we will allow 75 horse power as a basis of present comparison.

It must be remembered that this horse power was measured at the station and that no allowance need be made for loss in conductors or motors.

The writer of the article makes an allowance of 20 trains out of 120 as the number stopping at stations and during that brief interval using no current. When it is remembered that it takes about 87 seconds from the starting of a train from one station to the starting of the same train at the subsequent station and of this 87 seconds, 17 seconds are spent at the station and 32 seconds are spent with the power cut off and brakes applied, being over 50 per cent of the time spent during the total run, it will be seen that instead of 20 trains using no current, a proper allowance out of the 120 would be about 70 trains.

It will also be noticed that it has been assumed that 120 trains would make a round trip, giving intervals of one minute.

In this case again the difference in rate of speed has been neglected; as a matter of fact it would take 210 steam trains to do this service, and assuming that the electric trains would make the same speed, 200 electric trains, for the reason that the electric train does not have to stop as the steam train does

for the purpose of raking ashes, building up fires, etc., which could not be less for each steam train in a round trip than ten minutes. The cost of installation, based, therefore, on the above data would be about as follows:

Conductors and feeder rails.....	\$ 100,000 00
Laying insulators and connections.....	50 000 00
200 motor equipments @ \$6,000, each .....	1,200,000 00
15,000 horse power @ \$80.00.....	1,200 000 00
Total.....	\$2,550,000 00

But this is not all, comparing the locomotives and their effect on the track and structure with that of the motor cars, the savings in construction will amount to at least 25 per cent. of the cost for the steam road. This will be about \$40,000 per mile, or 20 miles at \$40,000. \$8,000,000.00. But this is not all; it is only fair to compare the two systems completely and not fair to compare the light afforded passengers by smoky kerosene lamps with the brilliant light obtained on an electric road. The only light approximating the electric light is the most improved system of gas-lighting for cars, which would cost about \$250 per car, as against about \$40 per car to install electric lights, effecting a further saving on 1,000 cars of \$210,000, and without referring to the saving of lighting stations and the coaling and water stations, we have as the investment to be compared with the steam, a total of \$1,540,000 as compared with 210 compound steam locomotives at \$6,000 each \$1,260,000.

Now, to make a comparison of the relative cost of fuel: We have, in a round trip of two hours, 210 trains covering about 8,000 miles; and for electricity, 15,000 horse-power for two hours at 4 lbs. per horse-power hour=60 tons. Steam, 8,000 miles, at 40 lbs. per mile=160 tons. As anthracite is used on the steam trains, the price still further emphasizes the difference in operating expenses, which would be for:

Electricity, 60 tons, at \$2 50.....	\$150 00
Steam, 160 tons, at { \$4 00, New York.....	640 00
{ 6 00, Chicago.....	960 00

It will be seen that under this estimate the difference between the cost of construction of the two systems is so small that it is unnecessary to carry the discussion further, as the assumption of the different rate of speed vitiates throughout the former comparison.

The above statement of saving refers to fuel only, there are other items. The saving of wages on the two hours of a full schedule would amount to \$240 in favor of the electric road.

The writer knows nothing about the reliability of the figures given in reference to compressed air, as no experiment has been carried on in this direction on a large enough scale to demonstrate its availability, to say nothing of the expense.

One of the common errors in regard to the electric road is the endeavor to assume that an electric road is to do much more work, in a much smoother and pleasanter manner than the steam road, and still at less expense. In one of the technical magazines a statement was recently made that a locomotive generates power at a far smaller first cost than any stationary steam plant on account of the stationary plant costing from five to ten times as much per horse-power as the cost of a locomotive per horse-power. This statement, while correct in itself, neglects the underlying factors of the operation of an electric road where the steam plant would certainly not be over 20 per cent of the total maximum power required to operate the trains. In the same article referred to, the conclusion is drawn that "Very small power units can certainly be operated more economically by distributing the power electrically from a central station. With large power units it is more economical to generate the power on the spot; just

where the dividing line is to be drawn will depend upon the circumstances in each particular case." This statement ingeniously hides the truth. It is not the size of the power units which renders it more economical to generate the power electrically, but the number. Having a given amount of power to generate, it can be distributed more economically by the use of electric transmission when the units are smaller in size. Bearing in mind that the economy of the motive power is not the only reason for the application of electricity on elevated railways, that the saving in dust, noise, gas and other so-called sentimental reasons must also have great weight, it becomes evident that it only requires a careful, thorough and scientific investigation of the subject to enable one to predict that the time is already come for the operation of elevated railways by electric power.

### ELECTRICITY VS. STEAM.

Electricity is constantly knocking at the door of the domain so long ruled with undisputed sway by the steam engine, and while the locomotive still snorts in derision, electricity is hopeful and progressive. While it will doubtless be many years before steam-produced electricity can hope to supplant the locomotive, it is by no means certain that the development of long distance transmission may not be so perfected that current produced by water-power may not accomplish this result. Electricity on elevated roads is proving successful and this is a long advance toward surface railroad work. A small part of the power now going to waste over the falls of Niagara would suffice to move all the trains on all the roads leading east out of Chicago. It will be a battle of economics. On the present condition of cost of power the Engineering News states:

"The fact has recently been prominently brought forward that the locomotive generates power at a far smaller first cost than any stationary steam power plant in existence. A rough estimate shows that a stationary steam power plant has a first cost five to ten times as great per horse-power as the cost of a modern locomotive. These figures have a most important bearing on the question which has been so much discussed, whether the electric motor can economically be substituted for the steam locomotive. Apparently a long step in advance will have to be taken by builders of stationary boilers and engines, and they will have to copy some features of locomotive practice before they can successfully attempt to distribute electric power for use on railways now operated by locomotives.

One of the chief grounds on which the popular belief in electric traction rests is the fact that for street car service the electric motor has displaced the dummy locomotives, which were formerly considerably used on city and suburban railways, especially in the South. But there was a good reason for this change. Putting a miniature locomotive at work hauling a street car at low speeds was like setting a giant to do a dwarf's work at a snail's pace. Because a steam engine capable of generating 200 horse-power and doing work for which less than twenty horse-power was actually required, was displaced by a 20 horse-power electric motor, it does not follow that electricity can economically displace the fast express locomotives of the present day, generating continuously nearly 1,000 horse-power."

AN IMPORTANT INTERURBAN.

Johnstown, Gloversville and Fonda Interconnected By Electric Railway.—The Business Carried and How it is Done.

In the early summer of 1891, a party of gentlemen, al more or less acquainted with the men and matters at Gloversville, Johnstown and Fonda, New York, conceived the plan of building an electric railroad to connect those three thriving towns, Gloversville is a young city of 15,000 people, Johnstown a town of 9,000, and Fonda an important station on the N. Y. C. & H. R. R. R., with a population of about 3,000.

Like the course of true love, the course of franchises did not run smoothly, but in spite of great opposition from previously organized companies and from a steam road traversing the same territory, the franchises necessary were acquired.

Early in the spring of 1892, a corps of engineers in charge of chief engineer W. Boardman Reed, began preliminary surveys for the road which was to be built on a private right of way instead of the highway. This was made necessary on account of the proposed carrying of freight, which was to be a large part of the business of the new company. Not only was it impossible to procure franchises for the freight traffic along the main highway, but the grade of the highway would not permit it. A route was determined upon survey completed and specifications prepared for bids, in July, 1892, and on August 2, contract was signed for the entire building and equipment of the road. In July, 1893, the main line to Fonda was in operation.

The construction of the main line, about nine miles long, involved the excavation of 175,000 yards of earth and rock, the building of three pieces of trestle, two iron bridges and about 1,000 yards of masonry. The track is of 56-pound T rail, laid on 6 by 8 by 8 hardwood ties, two feet between centers. The overhead line is of bracket construction with No. 0 copper trolley wire and six 0000 copper feed wires, running from the power house in Johns-



SCENE IN GLOVERSVILLE.

town, south to Fonda 5 miles, and four 0000 feed wires north to Gloversville, about four miles.

Besides the main line there is a two mile loop in the vilage of Johnstown and a four mile belt line in Gloversville. On unpaved streets T rail, planked, is used with satisfactory results, while in paved streets, Johnson 80-pound girder rail is laid, spiked directly on vulcanized Virginia pine ties.

THE POWER HOUSE,

is a substantial brick building about 70 by 90 feet, containing three 150-horse-power horizontal tubular boilers, one 300-horse-power and one 150-horse-power Russell four valve compound engine, with condensers, pumps and heaters. General Electric M. P. 100 K. W. generators are used. The plant is located in Johnstown, on the bank of a bright pure stream of water, furnishing adequate supply for boilers and for condensing.

The car house, a plan of which we show, is a frame building 150 by 68 feet, located in Gloversville, the headquarters of the company. There is a paved pit under full length of each track.

THE ROLLING STOCK.

The four cars which run over the main line between Gloversville, Johnstown and Fonda, are 35-foot combina-



FIRST CAR IN FONDA.



POWER HOUSE AT JOHNSTOWN.



CONSTRUCTING THE LINE.

tion cars, running always in same direction and turning on a Y at each end of the line. First is motorman's compartment, then baggage room 8 by 8 feet, smoking room of same size, and ladies compartment 13 by 8, with four-foot rear vestibule. These cars are very popular and have been found to be the thing for this interurban service.

There are also eleven, 18-foot vestibule cars for the local lines, four trailers and a summer equipment of five 10-bench and two 12-bench open cars. The combination cars first referred to and four of the 18-foot cars were made by Gilbert Car Manufacturing Co., and the open cars by the Ellis Car Company. McGuire and Taylor trucks are used. General Electric W. P. 30 motors propel the 18-foot cars and Westinghouse single reduction motors the 35-foot cars. All cars are equipped with the excellent De Witt sand boxes.

An important part of this road's equipment is the snow plow manufactured by the Massachusetts Car Company,

of Boston. Gloversville and Johnstown are noted for heavy snow and the electric plough has won the highest commendation for its work this winter. It is a nose plough, the nose being 3-feet high and concaved, and is provided with wings; wings not for flying but for making the snow fly.

CAYADUTTA PARK.

The enterprising management last summer, began the development of a beautiful park on its main line, between Johnstown and Fonda. This park covers 25 acres of wild and picturesque scenery, with a brook babbling and bounding through it. A dancing pavilion, refreshment stand, band stand and numerous summer houses, rustic seats, beautiful walks, pure cold spring water, are among the many attractions. During the summer scarcely a day passed without one or more picnic parties enjoying the beauties of Cayadutta park. It is intended also to

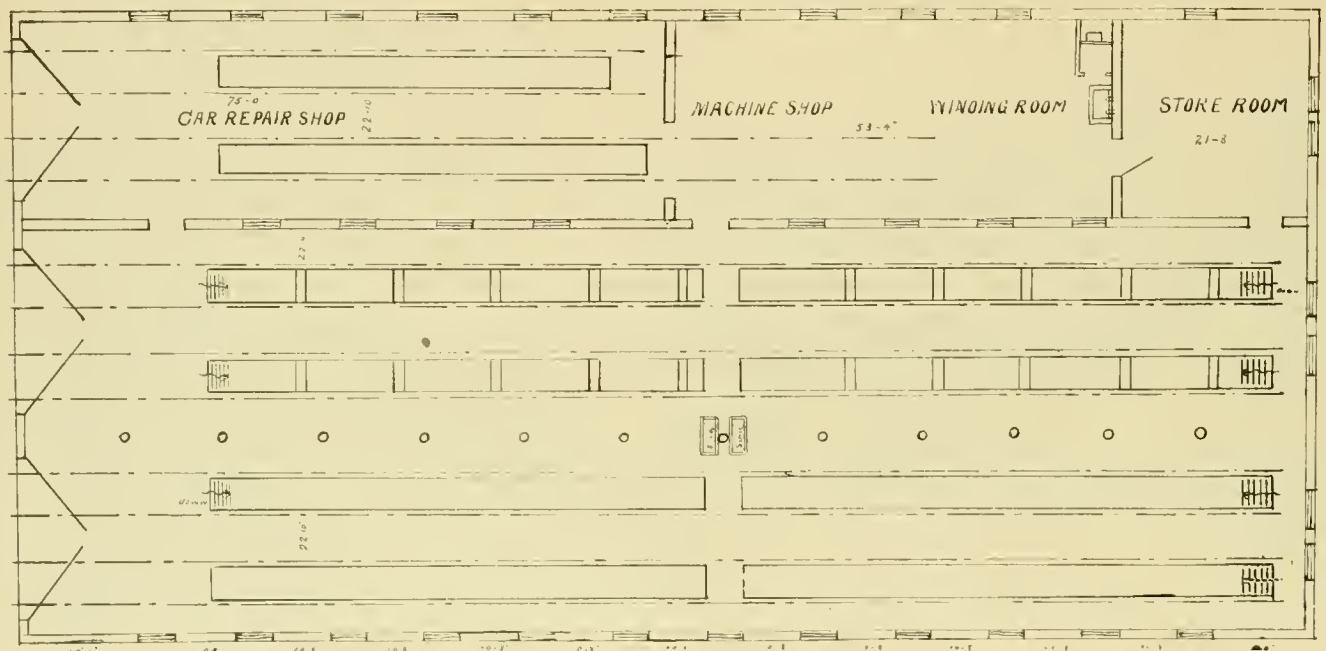

PLAN OF CAR HOUSE AND REPAIR SHOPS.

make an artificial pond of three or four acres, which will add much to the attraction of the place.

All the company's lines are single track with turnouts. Cars are operated on a schedule exactly similar to those of steam railroad instead of under certain regular headway, as is usual on electric roads. Each conductor is provided with a blue print time table, showing time each car is due at each turnout, and meeting points are indicated by a circle around the figures. There is probably not another electric railroad in the country operated so close to schedule time. A record is kept of each trip's earning and trips are taken off or put on as the traffic warrants.



T. C. FRENEYEAR.

The company maintains a private telephone line, with instruments at main office at Gloversville, car house, power house, Fonda, and general manager's residence.

Most prominent in the inception of an enterprise which has revolutionized the railroad situation in Fulton County, and

has involved \$2,000,000 worth of railroad property were T. C. Frenyear, at first secretary and for the past two years the efficient and progressive general manager of the Cayadutta Company. Hon. Everett Smith, the first president of the company and at that time mayor of Schenectady; Hon. J. Leslie Hees, its first treasurer, now treasurer of the F. J. & G. R. R., cashier National Mohawk River Bank of Fonda and deputy state treasurer; Hon. Jas. Shanahan, ex-state superintendent of public works, formerly president of C. E. R. R. and now president of the F. J. & G. R. R.



W. BOARDMAN REED.

W. Boardman Reed, is the electrical engineer.

TERRE HAUTE has passed an ordinance prohibiting the festive small boy from making the street cars a part of his play ground.

THE success of the Green fuel economizer at the Intramural power plant at the World's Fair has interested many street railway managers in this fuel-saving device. A part of the Intramural equipment is doing duty at Fort Wayne, Ind., the rest on the South Chicago Electric Railway, and the Fuel Economizer Company at

## C. E. R. R. TRIP REPORT.

-----1894. Car No.-----

Line,-----

Leave ----- Arrive -----

5 Cent Register No.		No. Fares	Amount	
Out				\$
In				
10 Cent Register No.				
Out				
In				
15 Cent Out	In			
20 Cent Out	In			
25 Cent Out	In			
30 Cent Out	In			
Total No. Passengers				
Cash		\$	\$	
Tickets				TOTAL
Transfers				TOTAL
Passes			\$	

CONDUCTOR. MOTORMAN.  
TRIP REPORT CAYADUTTA ROAD.

Matteawan, N. Y., finds its works full of orders for new equipments, among them a number for electric light and railway stations. One order is for one 5,000-horse-power for the Brooklyn City and another of 600-horse-power goes to the Springfield, Mass., line.

## Cayadutta Electric Railroad Company.

### DAILY TICKET REPORT.

187

DESCRIPTION OF TICKETS	Johnstown to Park and Return	Johnstown to Park and Return Half	Fonda to Park and Return	Fonda to Park and Return Half	Johnstown and Park	Johnstown and Park Half	Johnstown and Fonda	Johnstown and Fonda Half	Gloversville and Fonda	Gloversville and Fonda Half	Gloversville and Johnstown	LOCAL	Gloversville and Johnstown Package of 12	Local Package of 24	AMOUNT CASH RECEIVED
VALUE	30	15	10	5	15	8	20	10	30	15	10	5	1.00	1.00	\$

THE TROLLEY ON THE ROCK ISLAND BRIDGE.

Great bodies move slowly. The United States government is a great body. Therefore, it took a long time to get permission to run the trolley across the government bridge between Rock Island and Davenport. However,

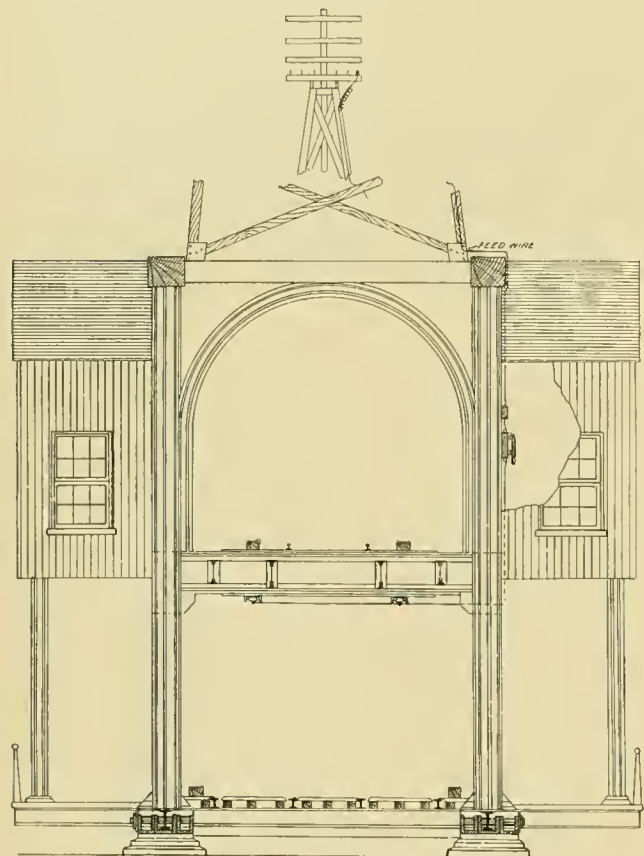

FIG. 1.—CROSS SECTION OF DRAW.

the horse car line now running on the bridge suffered by comparison with the electric systems at each end. The company knew that the affair would work out its own salvation in time, and that government permission would be refused until public sentiment was unanimously in favor of it. That time finally arrived, however, and permission has been granted and plans approved for stringing a trolley across the bridge. In crossing the bridge several

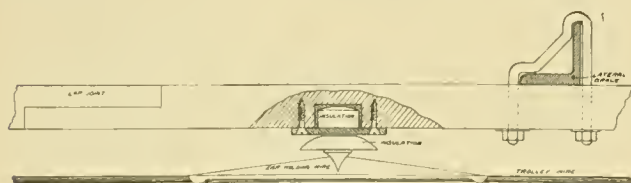

FIG. 2.—TROLLEY WIRE SUSPENSION.

different styles of trolley suspension had to be adopted. There is the bridge proper, a viaduct, and a filled-in approach. A section of the bridge proper can be opened as a draw. Figure 1 shows a section of the draw. The upper part is occupied by a railroad. Figure 2 shows

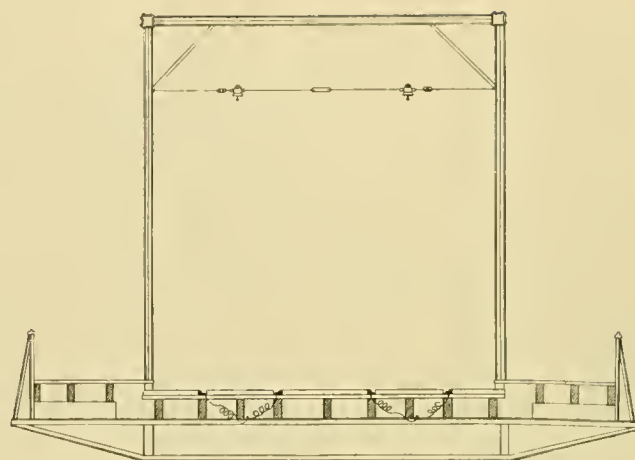

FIG. 3.—OVERHEAD CONSTRUCTION ON VIADUCT SPAN.

the method of hanging trolley wire from a 2x8 hard pine stringer. On the through spans of the viaduct a span

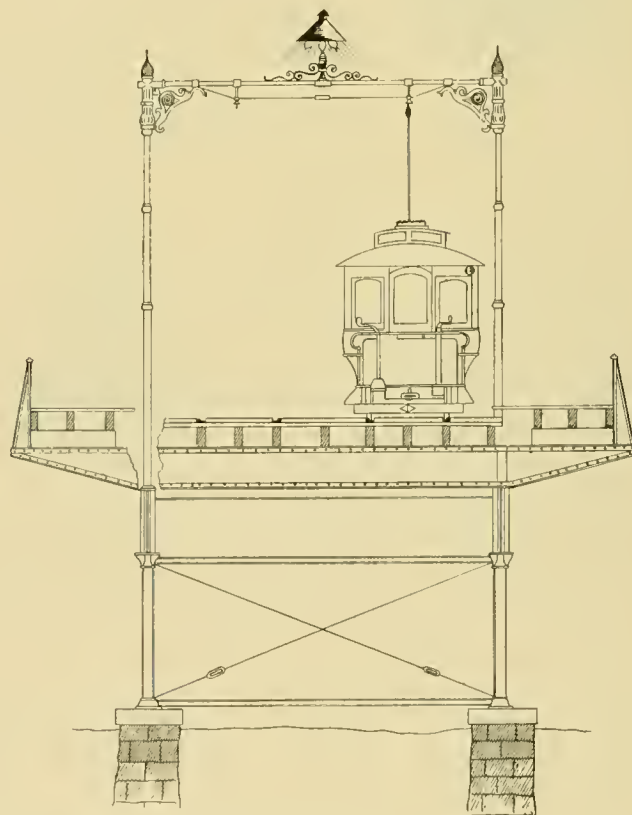

FIG. 4.—GAS PIPE ARCH ON VIADUCT.

wire construction as in Figure 3 is to be used. Figure 4 is the style to be used on a portion of the viaduct, the wires being suspended from ornamental gas pipe arches.

THE ambitious schemers for an underground railway in Chicago, are proposing a subterranean, four-tracked, electrically operated belt line to unite the elevated roads. The capital stock is placed at \$15,000,000, and the men interested as incorporators and directors are: Marcus Polasky, Morris Messenger and William M. Northrop, of Chicago, William Llewellyn, of Seattle, Wash., and A. M. Low, of Detroit, Mich., and the company is called the Chicago Central Sub-Railroad Company.



## MUNICIPAL PURCHASE OF ENGLISH TRAMWAYS.

By R. S. Tresilian, Assistant Secretary Dublin United Tramways.

The question of the purchase of the various tramway lines has again come prominently forward on the English side of the water, owing to a decision of the High Court of Justice which has just been pronounced, and which is likely to upset the calculations of those municipal authorities who thought they were going to get hold of paying concerns at, as the saying is, "the price of an old song," and a short outline of the facts as they stand at present may be interesting to readers, as contrasting the procedure in the two countries.

In the year 1870 a general tramway act (which, however, does not apply to Ireland, that country having been provided for under a previous act), was passed, and provisions were therein enacted that after the expiration of twenty-one years from the inauguration of any tramway, the municipal authority or authorities within whose jurisdiction the lines were constructed might, if it seemed well, notify the owner of its or their intention to buy, and forthwith the owner was bound to sell the whole of its undertaking at a price to be agreed on, and if not agreed on, to be settled by an arbitrator appointed by the Board of Trade; and it was enacted that this, in fixing the price to be paid, was to estimate "the then value" of the undertaking, making no allowance for past or future profits, or taking any other matter into consideration. The clause enacting this is so curiously worded that the first case was eagerly looked forward to by the tramway world, as establishing a precedent for future guidance, and, it was hoped, establishing the reading of a doubtful paragraph in the act.

The London Street Tramway Company were lately notified by the London County Council that they would, under the provisions of the aforementioned act, be required to sell their undertaking, and as the two bodies could not agree as to price, Sir F. Bramwell, C. E., was appointed arbitrator by the Board of Trade. On the hearing of the case he refused to hear any evidence as to the profits being earned by the company, either present, past or future, or as to the rental value of the lines, and gave an award, stating it was based on what sum it would at the moment cost the company, or the county council, to construct a new line, adding to that the sum it had originally cost the company to obtain powers (parliamentary and preliminary expenses), but deducting a certain allowance for depreciation, taking this to be the "then value" named in the act, and as the total sum awarded, £64,000, was only about one-third of that claimed by the company, this award was not accepted, and the company appealed on motion to the High Court to set aside the award, or to remit it back to the arbitrator with instructions that he should hear evidence of the rental value of the lines (stated by the company to be over £10,000 per annum).

This motion was heard a few days ago, and the Court, an exceptionally strong one from a legal point of view, has upheld the company's contention and referred the

case back to the arbitrator to fix a rental value, stating that the act never contemplated that the municipalities were to purchase valuable going concerns at the price of old iron, and that the words the "then value" contemplated much more than the county council thought, or perhaps wished to persuade themselves they thought.

This view was ridiculed by some of the Radical papers in London, whose whole wish seemed to be to urge the county council to buy the tramways, in order to provide free traveling for the masses; it is not at all unlikely that, owing to the interpretation of the Court, the municipalities, if they wish to buy, will have to pay a fair and reasonable price for the undertakings, and shareholders will not be mulcted out of their capital, which though now perhaps earning a fair dividend, was in the early days of tramway enterprise anything but remunerative.

DUBLIN, March 1894.

## AN ELECTRIC FRUIT LINE.

The country along the south shore of Lake Ontario, from Hamilton east, a distance of 22 miles to Beamsville, is noted as the garden of Canada. It is one of the finest fruit raising districts in the world, being protected on the south and west by the high ridge of table land which was the original cause of Niagara Falls and having the lake to steady the temperature. The district is at present traversed by the Grand Trunk Railroad, which however furnishes no adequate service for so important an industry. The Hamilton, Grimsby and Beamsville Electric Railway, now building runs east from Hamilton, through the above named towns and expects to do an extensive fruit business. By bringing fruit into Hamilton, good connections can be made with large cities over the country, especially with Toronto, which is only 3½ hours distant by lake steamer. The motor cars will be 28-foot vestibuled, with double McGuire trucks. The express and fruit cars will be 16-foot. There will also be a number of 36-foot double truck open trailers and 28-foot closed trailers to carry the crowds that will seek Grimsby Park. Beside this business there are 150 cans of milk to be carried daily to Hamilton from this district and also some general mail and passenger traffic now done by a stage line. A large building has been bought in the center of Hamilton for the purpose of a fruit market to dispose of the freight of the road.

"ELECTRICITY in warfare" is a familiar phase, but it took on a new meaning during a recent contest between the employes of the Brooklyn City Railroad Company and the deputy sheriffs of King and Queens counties, when an attempt was made to prevent hanging trolley wires on the Grand street bridge over Newtown creek. A deputy tried to arrest a workman, but the railway people were prepared for emergencies, and Foreman, McManus, arranged to touch up the deputy with the bare end of a live trolley wire. After several shocks the deputy let go and was helped off the scene of action.

## WALKER'S NEW DESIGN TROLLEY HEAD.

For some time rumors have been afloat that Superintendent I. B. Walker, of the Sioux City Street Railway, had designed a trolley head that was a model of simplicity and durability. We present herewith, a few illustrations of the device, and we think that our readers will agree that the rumor was not without foundation in any particular. Not including the wheel, this head consists of only four parts, viz.: the two halves of the harp, the journal or pin, and the bolt fastening the harp to the pole. There are no sharp corners or projections, and the whole harp presents a smooth, rounded surface. The journal is a case hardened steel tube of 1-inch outside diameter, and  $\frac{3}{4}$ -inch inside diameter. It is filled with dry graphite, which is allowed to escape and lubricate the bearing through four  $\frac{1}{8}$ -inch holes bored 90 degrees apart at the middle of the pin. If it is preferred to use graphite paste, a pin is used having screw head plugs in the ends. The feed is accomplished by giving the plugs a slight turn every night. Mr. Walker finds the dry graphite perfectly satisfactory and less trouble than the paste. The form of the harp

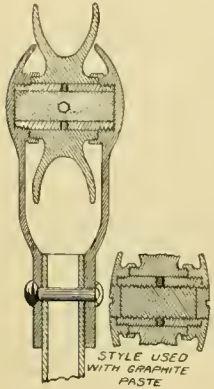

makes it almost indestructable. It was originally built with two bolts holding it to the pole, but one has been found sufficient, as the two halves are held firmly together by the journal. When a wheel is put in, the head needs no more attention until the wheel wears out. Judging from a five months use of this wheel, a harp will last two or three years. The ten to fifteen thousand miles run which will wear out a trolley wheel, causes a slightly perceptible wear on the bearing surface of the harp. The simplicity, strength and compactness of this head are great points in its favor.

## SNOW PLOW ON THE MOUSAM RIVER ELECTRIC LOCOMOTIVE.

The accompanying engraving shows the electric locomotive of the Mousam River Railroad, fitted with the snow plow. A full description of the road and locomotive can be found in the REVIEW for January. E. K. Day, superintendent, writes that they have not been stalled this winter and have lost no trips, being the only



electric road in Maine not blocked during a part of some day. The locomotive hauled during the year ending March 1, over 19,000 tons of freight, and 124,000 passengers were carried, being a good business for a line largely dependent on industrial operations, which were closed a good part of the year. Since our description of this road appeared, Mr. Day has received inquiries from all over the country, manifesting great interest in the road.

## WHAT FOOLS THOSE MORTALS BE.

A tall woman, heavily veiled, mounted the steps of a South Chicago City Railway car. It was while the small pox scare was at its height and everybody was rather gingerly watching his neighbor. Her veil finished it.

She sat down composedly, without raising the heavy curtain that obscured her features. The man next her edged away and whispered, "Ain't it awful?" Everybody was now on the qui vive and finally a nervous woman called a stop and bolted for the door. That settled it. Everybody was sure the woman's features beneath the veil must be bloated and noisome from the epidemic and a general exodus began.

It was then the lady raised the veil and nobody but the conductor and one passenger saw an alabaster complexion, large, dreamy black eyes, rosy cheeks and a double row of small white teeth displayed by amused and smiling lips.

She looked at the sole brave passenger and said, "I guess those people are afraid of me!"

THE street railway employes of St. Louis have organized in the K. of L. organization.

HITCHING ON ORDINANCE AT ALLEGHENY.

Superintendent Foster of the Federal Street and Pleasant Valley Railroad, Pittsburg, sends us a copy of a recent manifesto of the city council of Allegheny, which was found such good reading matter that the company printed an extra thousand copies. In the interest of publicity and promotion, these placards are prominently pasted along the route every week or two. Following is a copy:

# AN ORDINANCE

## Relative to jumping on or hanging on Street Cars while in motion.

Section 1. BE IT ORDAINED AND ENACTED BY THE SELECT AND COMMON COUNCILS OF THE CITY OF ALLEGHENY, AND IT IS HEREBY ORDAINED AND ENACTED BY AUTHORITY OF THE SAME, That on and after the passage of this ordinance it shall be unlawful for any person or persons to jump on or hang on to street cars in the City of Allegheny while in motion, for the purpose of obtaining a ride thereon without paying his or her fare. All persons so offending shall be subject to arrest, and upon conviction thereof before any Police Magistrate or the Mayor, shall be subject to a fine of not less than one (\$1.00) dollar, nor more than five (\$5.00) dollars, and in default thereof committed to the county jail for not less than twenty-four (24) hours, nor more than five (5) days.

Sec. 2. That so much of any ordinance as may conflict with or be supplied by the foregoing, be and the same is hereby repealed.

SUNSHINE IN SEATTLE.

Superintendent Hass, under date of March 21, writes us as follows:

"On page 129 of March 15 Review, you say only forty days, until the festive summer cars will begin to make their debut, but each one deserves a thorough overhauling in the meantime."

The Seattle City Railway, "calls" you, and says that on the date above written, our summer cars made their debut for the spring of 1894, under one of the balmy skies of this glorious northwest, amid scenery that you could not help but admire, to the east, the snow capped Cascades, to the west, the Olympics, in their sublime grandeur, to the south, 65 miles away, old Mount Rainier lifts its 14,444 feet of majesty, with its summit ever crowned with snow, while to the north, Mount Baker

keeps its eye on our Canadian neighbors to catch the first move for annexation with Uncle Sam. The waters of Puget Sound, bathe the western and Lake Washington the eastern limits of our beautiful Queen City of the Northwest, our own Seattle. Lesche Park is carpeted in green, be-studded with many colored crocus, pansies, daisies and violets, which will soon give way to a most beautiful display of tulips and other early flowers.

The "Zoo" is in good shape, and already the travel has set in to see and enjoy the same. The open cars are all in fine shape for use, and the public say they are the finest in the city, manned by the most polite and courteous conductors and gripmen in the country.

My compliments to Decatur, Ill., on her second of March open cars, we must be a close second.

THE LAWRENCE TRACK BRAKE.

A new track brake for street cars is herewith illustrated. It is the invention of William Lawrence, of Worcester, Mass., and is intended to be used in connection with the Kane brake. The shoe consists of a frame of cast metal with diagonal slats, into which are inserted removable wedges, set securely in the frame and diagonally to the track. The end pieces are rounded. The details of the toggle mechanism are readily seen from the illustration.

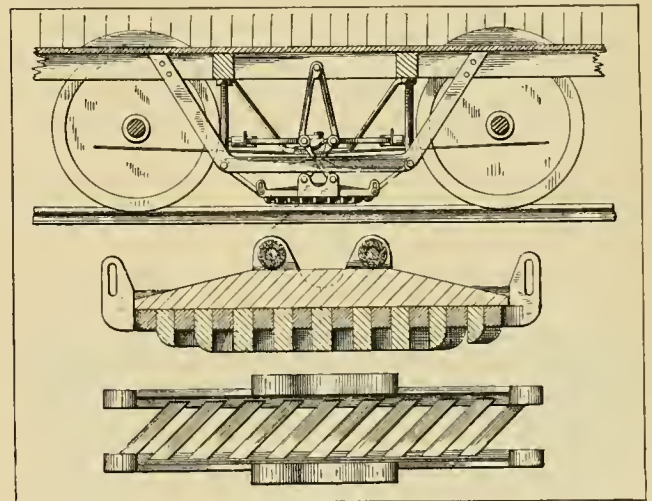

The advantages claimed for this shoe by the inventor are: Economy, because the bearing sections may be easily removed when worn out; adequate bearing surface to the rail and sureness of contact, as the diagonal arrangement pushes obstructions, snow and ice from the rail. "The brake and shoe have been used on 6, 8 and 10 per cent grades at Worcester, Mass., and stopped the trains without the use of any other brake," says the inventor. It is however, intended primarily to be used in conjunction with a wheel brake.

The Chicago General Street Railway Company has made a communication to Mayor Hopkins, offering to co-operate in establishing a 4-cent fare throughout Chicago.

REFUSE BURNING IN POWER PLANTS.

The question of refuse burning has never been brought to the attention of power users in this country to any great extent. This is partly because of the proverbial American wastefulness and partly because of the few cities where refuse amounts to enough and is of the proper quality to admit of burning it for power purposes.



THE PLANT AT NIGHT.

Garbage crematories, where the refuse of a city is disposed of at considerable expense, are becoming common, and the question of making steam by the burning of refuse is beginning to receive some attention. It is evident that if garbage is to be burned, the heat incident to the process might as well be utilized as to go to waste. For years the Chicago City Railway burned manure from its stables (where shavings were used for bedding) under the boilers of its cable plant at 2020 State street. From the standpoint of economy it was a great success, as otherwise the refuse had to be shipped into the country.

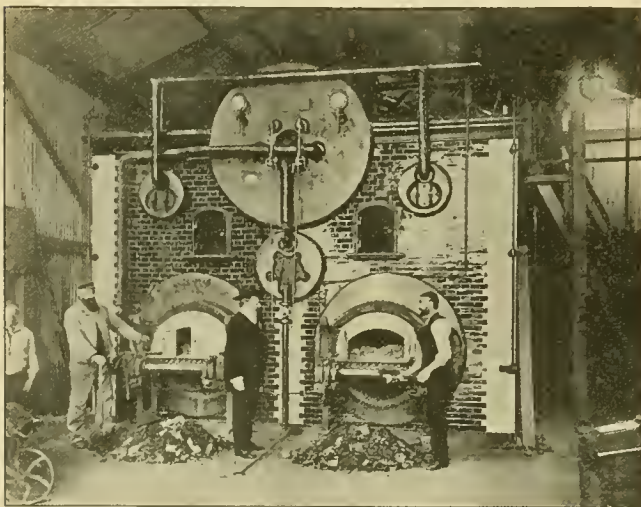

FRONT OF BOILER.

About 20 per cent of coal was mixed with the manure. The mixture was fired by hand, as mechanical stokers had not at that time been installed. A fan blower was used, which kept a pressure in the fire boxes of 2 to 3

pounds. Although a great success economically, the smell was such that objection was raised and the practice had to be stopped. Just now the Livet system of refuse burning is attracting attention here and in England. The principle of Livet's steam generator as it is called, is that the size of the flues is gradually increased from the furnace to the chimney. The object of this construction is to give a high velocity to the air going through the furnace bars, without losing a great amount of heat up the chimney. The gases under this arrangement are given a constantly decreasing velocity as they travel toward the stack, owing to the increasing cross section of the passages. We present herewith a sketch of the boiler showing it in section. The fire is located as in a Cornish boiler, in the space E. The gases pass to the back of the boiler and are conducted back and forth through flues 1, 2, 3 and 4, in the order named. Two 100-horse-power furnaces have been running for six months at Halifax, England, in an electric light plant.

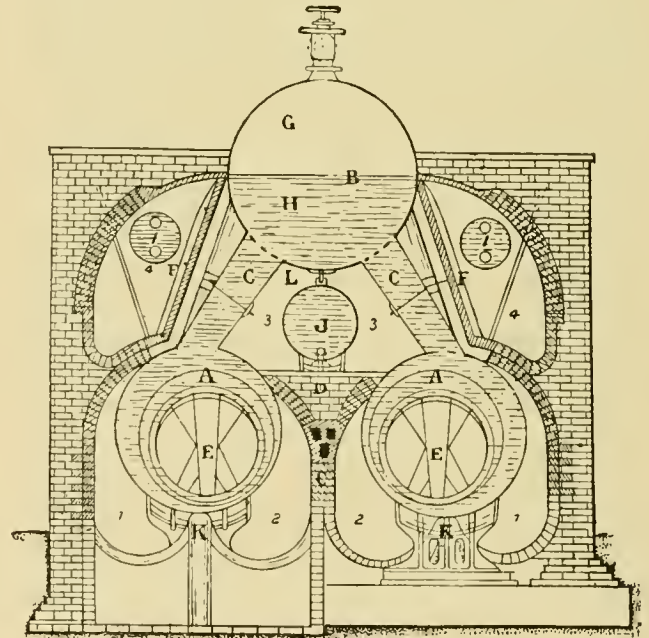

SECTIONAL VIEW FURNACE AND BOILER.

Nothing but rubbish is used in the furnace. It is stated that the cost of one indicated horse-power per annum, using coal in that neighborhood, is \$45, and with this furnace and the use of rubbish is \$15. Our engraving represents the Halifax plant at night.

A RACK railway is projected for the ascent of Ben Nevis, the famous Scotch mountain. The undertaking will use \$150,000 but it is expected that the tourists will then number 20,000 per annum. The maximum gradient will be 1 in 3 for 600 yards. The total length will be one mile.

THE Montreal (Canada), Park & Island Railway is now complete to Sault au Reclot. It was planned by the Williams-Corriveau syndicate, which transferred its franchises to the present company.

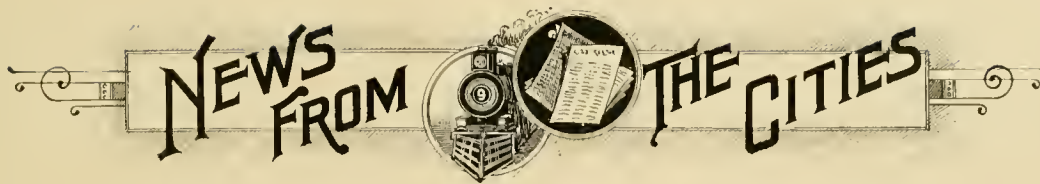

**Alabama.**

MONTGOMERY, ALA.—The Montgomery Street Railway will relay old lines and put in eight miles of new. The whole system will be made electric.

MOBILE, ALA.—Mobile Street Railway Company elects: J. C. Morris, New Orleans, president; F. J. Gasquet, New Orleans, vice-president; R. Semmes, Mobile, treasurer, and general manager, and R. B. Owen Jr., secretary.

**Arkansas.**

FORT SMITH, ARK.—Calvin S. Brice and other Ohio men are interested in the million-dollar trust deed filed by the Fort Smith and Van Buren Electric Street Railway, Light & Power Company to the Continental Trust Company of New York. It will provide for great improvement.

**California.**

OAKLAND, CAL.—The board of supervisors has granted a franchise for an extension on the San Leandro & Haywards line.

POMONA, CAL.—Reports that the electric railway scheme has been abandoned are denied, and it is said the line is to be put through soon.

SAN FRANCISCO, CAL.—The court has decided that the trolley may be used on Mission street. This is a victory of the Market Street Cable Company over the city.

SAN FRANCISCO, CAL.—Oakland, San Leandro & Haywards Electric Railway, records mortgage of \$250,000 in favor of the California Title & Trust Company, to secure bonds.

REDLANDS, CAL.—There is some prospect of a belt electric line being built in Redlands. Power will be used from the Light & Power Company's plant. Eastern parties have just bought \$40,000 stock in the latter.

SAN FRANCISCO, CAL.—Frank Simpson retires from the superintendency of the San Francisco and San Mateo Electric Railway, and Behrend Joost takes the place of general manager as well as president. New lines and extensions are to be built.

**Colorado.**

PUEBLO, COL.—The State Trust Company of New York asks the federal court for the foreclosure of a trust deed to secure payment of \$500,000 first mortgage bonds of the Pueblo City Railway.

DENVER, COL.—D. H. Moffat, president of the First National Bank, J. C. Montgomery and J. B. Thompson, of Chicago, are reported to be negotiating the purchase of the Detroit, Mich., Street Railway franchise. The city claims the old franchise with the Detroit Citizens expires this year.

**Connecticut.**

BRIDGEPORT, CONN.—Col. Hest has notified the council that his company will be ready to begin the construction of the electric system in about a week.

NEW HAVEN, CONN.—Edgewood Street Railway Company, Fred S. Wardwell, president and general manager, wants bids on two and a half miles of line material. The company has charter for five miles of road from center of New Haven to Westerville.

NEW HAVEN, CONN.—The officers of the Manufacturers Street Railway Company are: President, George S. Barnum; vice-president, N. W. Kendall; secretary, F. L. Bigelow; treasurer, S. J. Fox. They will build a street railroad for freight hauling to the factories owned by the men who will build the road.

**Chicago.**

CHICAGO.—The West & South Towns Street Railway files specifications of damages to the amount of \$600,000 against the West Chicago Street Railroad Company.

CHICAGO.—Judge Tuley dismisses the Vanderpool injunction against the Twenty-second street line. It may now be finished. C. L. Bonney, Tacoma Building, president.

CHICAGO.—J. W. Casselman, of the North Side Electric Railway Company, says that the road, if franchise is granted, will be built by the men behind the Jefferson Street Railway.

A new elevated railway ordinance is introduced into council by Alderman Finkler. The company is called the Chicago North Division Elevated Railway.

CHICAGO.—The Chicago & Morgan Park Electric Railway Company, files incorporation to build from the city to Morgan Park & Blue Island. Stock \$500,000, incorporators, B. Frank Deacon, Charles S. McCoy, Samuel P. Hubbard, Frank Foster and Ralph Bogle, all supposed to be of Chicago. The Chicago City Railway franchise has been passed over the mayor's veto, but incorporating some of his suggestions for amendment. The rights cover about 100 miles and do not compel the lighting of the streets, vote was 51 to 11.

CHICAGO.—The ordinances introduced into the city council asking for extension trolley franchises for the City Railway have been passed. The lines granted trolley rights are: Twenty-sixth, Thirty-first, Thirty-ninth, Fifty-first streets; Archer avenue, from State to Thirty-eighth street, thence to the terminus; Forty-third, from the eastern terminus to State along Root street to the terminus; Halsted street, from Archer avenue to the southern terminus; Ashland avenue, from Ashland avenue to the southern terminus; on Hanover and Wallace streets; on State street and Sixty-third street south to its intersection with Vincennes avenue, and thence to the terminus. Poles are to be between the tracks, Indiana avenue excepted.

**Illinois.**

AVON, ILL.—The Milling Company wants to build a commercial electric tramway to carry fire clay.

LA SALLE, ILL.—The City Electric Railway will build a one-mile loop this spring. A. G. Danas is general manager and purchasing agent.

PICKNEYVILLE, ILL.—Incorporated: The Pickneyville Street Car Railroad Company; capital stock, \$4,000; incorporators, Herman C. Henke, Philip Gruner, Henry Driemeyer, H. P. Huntsinger, and W. K. Murphy.

DIXON, ILL.—President J. S. Ticknor and H. B. Andrews, of Rockford; M. K. Bowen, superintendent of the Chicago City Railway, and Clift Wise, of the Complete Electric Construction Company, Chicago, have held conference with citizens in regard to the Rockford-Dixon Electric Railway. Work will begin soon.

QUINCY, ILL.—A citizens' committee, consisting of Charles T. Hayward, Dr. D. H. Shields, Judge Jasper Turner, Hon. J. C. B. Thomas, of Palmyra, and Col. H. A. Buchanan, of Philadelphia, met recently to consider the building of an electric road between Quincy, Hannibal and Philadelphia. Such a road is said to require a \$200,000 investment.

**Indiana.**

MARION, IND.—Howard Cale has been appointed receiver of the Queen City Electric Railway.

INDIANAPOLIS, IND.—City Attorney Scott is preparing a complaint against the Citizens' Street Railway Company urging that the company be ejected from the streets.

LAFAYETTE, IND.—Permission is granted J. Levering Jones, of Philadelphia, to extend the Lafayette Street Railway into the fair grounds. The work is to be completed by June 1.

NEW ALBANY, IND.—John McCloud has been made receiver for the New Albany Street Railway Company, which has been declared insolvent, having defaulted interest on \$150,000 bonds.

MICHIGAN CITY, IND.—F. H. Root, manager of the Lake Cities Electric Street Railway Company, says the change of horse to electric traction will begin soon. Power house will be built here. Some supplies bought.

INDIANAPOLIS, IND.—Leon O. Bailey, Dr. R. C. Light et al, have returned from the East, where a consultation has been held concerning the Broad Ripple road. The Farmers' Electric Railway Company and the Citizens' Street Railway Company are both after the franchise also.

RICHMOND, IND.—It is reported that the electric road now in receiver's hands, is in danger of collapse. The Union Trust Company, of St. Louis, foreclosed some time ago on a \$212,600 mortgage, and now the court admits a General Electric claim of \$32,000 and the Cambria Iron for \$5,000; City also claims \$15,000.

INDIANAPOLIS, IND.—In the receivership of the Marion Street Railway Company, Judge Woods has allowed Chas. B. Catting, E. Packard, et al., trustees of \$60,000 of the company's bonds; Metropolitan Trust Company and the General Electric to file cross bills for foreclosure of mortgage. Permanent receivership decision reserved.

### Iowa.

DAVENPORT, IOWA.—D. A. McGugin, of this city, railroad construction contractor, will receive bids on oak ties for a street railway line.

SIoux CITY, IA.—The South Sioux City Street Railway will enter the city via the Pontoon bridge, and will electrify entire line and extend to Crystal park.

KEOKUK, IA.—Judge Banks orders Gate City Street Railway to be sold in four weeks, foreclosing mortgage securing \$85,000 in bonds held by Central Trust Company, of New York.

SIoux CITY, IA.—Execution is issued against the Sioux City Street Railway Company in favor of the Fidelity Loan & Trust Company, on a judgment of \$563,000. Property will be sold in three weeks. Bondholders propose to organize a company and operate the road.

SIoux CITY, IA.—A mortgage for \$400,000 has been filed by the Consolidated Street Railway Company to William Tod, of New York. This means change of cable to electricity until such time when traffic shall warrant resumption of cable.

SIoux CITY, IA.—Form of decree granting foreclosure against the elevated railway is complete. Claims are declared a lien in this order: Unpaid court costs; receiver's bills of J. A. Jackson, \$1,925; fees of receiver's attorneys, \$2,000; receiver's accounts and certificates, \$1,334 and \$15,000 respectively; Kings Bridge Company, mechanics' lien, \$9,465; Northern Car Company, mechanics' lien, 10,008; other liens \$7,000; Manhattan Trust Company, mortgage, \$302,906; Railway Equipment Company's claim continued for further hearing.

### Kentucky.

NEWPORT, KY.—The Evergreen & Newport Electric Railway will begin construction within a few weeks.

HENDERSON, KY.—The Henderson Street Railway will put in three and one-half miles of electric road this spring.

NEWPORT, KY.—Newport & Evergreen Cemetery line contract has been let to M. J. Degnan & Co., of Cleveland, O.

COVINGTON, KY.—South Covington & Cincinnati Street Railway Company, is arranging to build a fine summer resort at Ludlow Park.

### Louisiana.

NEW ORLEANS, LA.—The St. Charles Street Railway franchise is extended for twenty-five years, and the line is to be operated electrically. Bids will be asked for the privilege by the city.

### Maine.

AUGUSTA, ME.—Augusta, Hallowell & Gardiner Electric Railway reports earnings, gross, \$41,348; total expenditures, \$27,463.

BANGOR, ME.—Chartered: the Bangor Electric Light, Heat & Power Company at \$30,000 by Milton Flory, B. F. Miller, David Huddleson, Thomas Dichett, John H. Werner, Bangor; William Bray, East Bangor.

### Maryland.

BALTIMORE, MD.—A senate bill is engrossed authorizing the Baltimore & Washington Transit Company and the Edmonson Avenue, Catonsville & Ellicott City Electric Railway Company to consolidate as the Baltimore & Washington Electric Transit Company.

BALTIMORE, MD.—Incorporated, the Randallstown, Granite & Harrisonville Electric Railway. The incorporators named are James W. Offutt, Edward W. S. Choate, R. P. Choate, Aaron Weber, Dr. H. J. Hebb, Henry C. Luttgerding, Albert Weber and George E. Lynch. The capital stock is \$50,000.

BALTIMORE, MD.—The Baltimore & Loretly Railway Company is incorporated to build extensive suburban electric system and to connect with Baltimore railways. Incorporators named are: J. F. Waggaman, of Washington; Walter Townsend, of Baltimore county; Robert D. Carter, Harry Hebden, D. C. Bennett and A. J. Robinson, of Baltimore city.

BALTIMORE, MD.—A new electric line from here to Washington is contemplated. The incorporators of the new company are: Dr. Francis Thomas of Montgomery County; Harper Carroll, of Howard County, George Yeakel, of Baltimore County, and Alexander Brown, Samuel E. George, N. W. Williams and Henry W. Williams of Baltimore. The capital stock is \$1,000,000. This is not the "boulevard line."

### Massachusetts.

SPRINGFIELD, MASS.—The Springfield Street Railway has begun work on its new Margaret street power house.

BOSTON, MASS.—The West End Street Railway will extend to Somerville this spring. The Highland avenue line will also be extended to Davis square.

NORTHAMPTON, MASS.—The Northampton Street Railway Company is making moves to run branches to Easthampton and Williamsburg this year.

BOSTON, MASS.—It is reported that the General Electric will furnish \$1,000,000 worth of machinery to the Cataract General Electric Company, of Niagara Falls, N. Y.

SPRINGFIELD, MASS.—The Springfield Street Railway has filed a petition with the city clerk for a location of its route from the Liberty street terminus to Chicopee Falls.

NEW BEDFORD, MASS.—The contract for building the Dartmouth & Westport Electric road has been let to Arthur Hodges, of Boston. To be finished by June 20.

HAVERHILL, MASS.—The Lowell, Lawrence & Haverhill employes form benefit association. President, James H. Forum, Haverhill; secretary, Harry Holmes, Lawrence.

SOUTHBRIDGE, MASS.—Contracts are being arranged to build the Southbridge, Sturbridge & Brookfield Railway between the points named, thirteen miles; president, Frederick D. Fisk, of Boston, and Samuel L. Minot, of Boston, engineer.

### Michigan.

DETROIT, MICH.—The City & Suburban has secured all of its franchise, from the city limits to St. Joseph's retreat

ANN ARBOR, MICH.—Efforts to consolidate the Ann Arbor and Ypsilanti lines are finally abandoned, as no agreement was reached.

NEGAUNEE, MICH.—The Negaunee & Ishpeming Street Railway and Electric Company holds its annual meeting April 16, at Negaunee.

BATTLE CREEK, MICH.—There seems to be little chance of the Battle Creek Electric Railway starting up this summer. The finances of the road are in a bad tangle.

DETROIT, MICH.—P. J. Jacobson, of Detroit, and J. A. Dawson, of Toledo, O., say that the Detroit-Toledo Electric Railway will soon be running.

DETROIT, MICH.—Another syndicate, this time of New Yorkers, is said to be after the Detroit franchise. John B. Corliss and Henry M. Duffield are said to be the promoters.

GRAND RAPIDS, MICH.—The long talked of electric line to North Park will now probably be built by the Consolidated Street Railway Company, which will change the dummy line to electricity.

GRAND RAPIDS, MICH.—Consolidated Street Railway Company has begun work on the North Park line, changing it to electricity. The summer resort business will be extensively worked this summer.

DETROIT, MICH.—An agreement is said to be effected between the Citizens Street Railway Company and the city, by which the company grants eight tickets for twenty-five cents, five-cent single fare, and eventual municipal ownership of street railways. There is no confirmation of the story from the company.

DETROIT, MICH.—The Detroit & St. Joseph's Retreat Electric Railway Company will be known as the City & Suburban, and is incorporated by Elwood T. Hance, John A. Russell, J. E. Sullivan, John C. Calahan, Charles C. Kellogg and William P. Lane. The railroad will be known as the City & Suburban Traction Company.

## Minnesota.

STILLWATER, MINN.—The date set for the sheriff's sale of the Stillwater Street Railway is May 7.

STILLWATER, MINN.—It is rumored that local capital will reorganize and work the Stillwater Street Railway, which will soon be sold at Sheriff's sale. Judgment is for \$67,709.

DULUTH, MINN.—The City Railway Company, of Duluth, is officered as follows: Andrew H. Burke, president; Henry E. Harris, secretary and treasurer. Financial backing is secured and the city franchise has good prospects.

MINNEAPOLIS, MINN.—Master Mechanic William Cooper has resigned from the Twin City's Company. The work will be divided at present, Assistant Master Mechanic Keister taking part. Mr. Cooper goes to Brooklyn, N. Y.

DULUTH, MINN.—Receiver J. P. Johnson, of the Tower & Soudan Street Railway, finds nothing to receive, and asks to be allowed cease operation of road, which, he says, is absolutely worthless and mortgaged for \$25,000 to the American Loan & Trust Company.

## Missouri.

ST. LOUIS, MO.—Lindell Electric Railway Company has bought 18,000 ties, and will immediately push proposed extensions.

ST. LOUIS, MO.—The Fourth Street & Arsenal Street Railway is about to change from horse to electricity.

ST. LOUIS, MO.—Clayton & Creve Coeur Railway Company has applied for a franchise to construct electric railway line between points named.

NORTH KANSAS CITY, MO.—The Kansas City Street Railway is owned by the Kansas City & Atlantic Railroad Company. It is not being operated at present, but will probably start again soon.

ST. LOUIS, MO.—J. H. Bobring has secured a franchise for an electric road to the park to be built by the Central Sharp Shooters' Association. It will be operated as a branch of John Scullin's Carondelet line.

SPRINGFIELD, MO.—Springfield-Robberson Avenue Electric Street Railway is sold by sheriff for \$5,500 to local capitalists, who will immediately push construction and improvement to make it a rival to the Metropolitan line.

ST. LOUIS, MO.—At its next session the County Court will consider the application of the Clayton & Creve Coeur Railway Company for a franchise to construct and operate an electric railway between Clayton and Creve Coeur Lake.

KANSAS CITY, MO.—Waldo Land & Investment Company is formed to buy 600 acres from 47th to 76th streets and build a boulevard electric line of three miles. Eli S. Young, president; Willard E. Winner, secretary. Cincinnati capital.

ST. LOUIS, MO.—It is reported that W. L. Johnson, of the South St. Louis Electric Express Company, has retired to take charge of Cincinnati street railway property owned by himself and brothers A. L. and Tom Johnson, of Cleveland, O.

ST. LOUIS, MO.—J. B. Case, L. R. Blackmar, S. F. McCormick and other well-known capitalists have taken charge of the Manchester Road Electric Railway and a Land and Improvement Company. They will complete the railway immediately.

KANSAS CITY, MO.—Incorporated: Kansas City & Waldo Railway, of Kansas City. Capital, \$150,000. Incorporators: W. E. Winner, George Law, E. S. Young and others, to construct a railway from Kansas City to Waldo Junction, a distance of five miles.

KANSAS CITY, MO.—Judge Henry has appointed Robert Gillham receiver for the Northeast Electric Street Railway Company, owing to the pressure of the Westinghouse Electric & Manufacturing Company with a claim of \$20,000 against the road. The request was made by the officers of the road.

ST. LOUIS, MO.—The Union Railroad Company, the Northern Central Company, Citizens' Railway Company, the Cass Avenue & Fair Grounds, united in the National Railway of Chicago, elect directors as follows: D. G. Hamilton, C. L. Raymond and George P. Smith of Chicago and Robert McCulloch, Smith P. Galt, C. N. Duffy and Henry Crosman, of St. Louis.

KANSAS CITY, KAN.—Merriam Park, Rosedale & Kansas City Railroad Company files amended charter to build six and one-half miles of road. Capital stock, \$50,000. Officers: A. A. Rearson, president; B. F. Hollenback, vice-president; T. J. Wilson, secretary; and C. W. Brown, treasurer.

The West Side Street Railway Company will improve Brown Park and add summer attractions. This is in Kansas City, Mo.

ST. LOUIS.—The board of public improvements has approved the plans of the Grand Avenue Railway and construction will, it is said, begin within two months. The officers of the company are St. Louisans: C. G. Stifel is president; J. W. Buel, vice-president, and Edwin H. Conrades, secretary and treasurer. The other directors are J. G. Butler Edward Taussig, D. P. Slattery, E. C. Donk, J. E. McKeighan, Thomas Halpin and George O. Carpenter.

## Montana.

ANACONDA, MONT.—The Gravity Cable Way & Transportation Company is figuring on the construction of three miles of cable way, southwest of this city, for hauling cordwood.

ANACONDA, MONT.—The Anaconda (Mont.) Electric Railway, Light & Power Company, C. R. Holmes, superintendent, is in the market for one 30 or 50-arc-light machine, with full equipment, including lamps. They are in a big hurry and want full particulars, prices, and everything to enable them to judge whether writers have what is wanted. No time for lengthy correspondence. This plant is for lighting the new converter of the company, and noise of lamps is no objection. Must know how soon shipment can be guaranteed.

## Nebraska.

SOUTH SIOUX CITY, NEB.—The South Sioux City Electric Motor Street Railway, of which Frank Hunt is president, J. P. Twobig, treasurer, and C. D. Smiley secretary and general manager, will build three miles additional at once, either horse or electric.

## New Jersey.

JERSEY CITY, N. J.—The North Hudson County Railway Company gets extensive franchises in this city.

PLAINFIELD, N. J.—The Street Railway Company elects: President, Thomas Nevins; vice-president, Dr. J. T. Fritts; secretary and treasurer, Chandler Riker.

BRIDGETON, N. J.—The new car house of the South Jersey Traction Company has been wrecked by a storm. Three new motor cars smashed.

WOODBURY, N. J.—The Camden, Gloucester & Woodbury Electric Railway Company has made formal application for the extension of the road through this city.

JERSEY CITY, N. J.—The new officers of the Consolidated Traction Company have been elected with the following management: Executive committee, Edward F. C. Young, M. R. Shanley and B. Naughton; director general, M. R. Shanley; general manager, David Young.

PLAINFIELD, N. J.—The Plainfield Street Railway Company elects the following officers: President, T. N. Nevins; vice-president, T. J. Fritts; secretary, Chandler W. Riker; directors, James Jackson, J. M. Hetfield, Cortlandt Riker, T. N. Nevins, Jr.; superintendent, Mr. Adleman. The matter of extension was not discussed, and nothing will be done for the present. The condition of the system was reported to be excellent.

### New York.

GLOVERSVILLE, N. Y.—Fire guts building of the Cayadutta Electric Railway.

CHARLOTTE, N. Y.—The Grand View Beach Railroad has decided to build a new power house to replace the one burned some time ago.

SYRACUSE, N. Y.—The Syracuse Electric cars are to be equipped with life guards.

BUFFALO, N. Y.—F. O. Rusling appoints W. A. Reddy assistant superintendent of the City lines.

HOMER, N. Y.—Cortlandt & Homer Street Railway will change to electricity. Rights to change are being acquired.

NEW YORK CITY.—The Jarvis-Conklin syndicate reorganization committee represents 75 per cent of the assets and is at work reorganizing.

OGDENSBURG, N. Y.—Ogdensburg Street Railway, five miles horse, seven cars, is for sale. H. B. Hickok, superintendent; W. H. Daniels, president.

SYRACUSE, N. Y.—Consent of the necessary number of property owners has been obtained for the installation of the trolley on the People's Railroad.

NEWBURG, N. Y.—Newburg Electric Railway contracts with P. Delaney & Company for power plant. The Dixon Steam Engine Works will build the engines.

WATERLOO, N. Y.—The Highway Commissioners have granted the Seneca & Waterloo Electric Railway right to build a road through the turnpike. Construction will probably begin soon.

NEW YORK CITY.—A. W. Field, vice-president of the Peckham Motor, Truck & Wheel Company, has opened a Boston office at room 315, No. 53 State street, and will take charge of same.

ONEONTA, N. Y.—The Oneonta Street Railway, a horse line two and a quarter miles long (a good line to change to electricity), will sell to right parties. T. D. Tallmadge, Jr., is general manager.

BROOKLYN, N. Y.—Long Island Electric Railway Company is organized at \$600,000. The officers are: A. R. Hart, president; Charles H. Mullin, vice-president; Clarence Wolf, treasurer, and J. C. Von Arx, secretary.

NIAGARA FALLS, N. Y.—The Niagara Falls, Whirlpool & Northern Electric Railway has secured its franchise for fifty years for a trolley line to the northwestern part of the city. The line must be completed by October 1.

SYRACUSE, N. Y.—Preliminary steps are being taken to foreclose the Central Trust Company's mortgage on the Syracuse Consolidated Railway Company, given to secure \$1,250,000 in bonds. Louis Marshall, of Butler, Stillman & Marshall, is attorney for the Trust Company, and C. L. Stone for the receiver.

NEWBURG, N. Y.—Newburg Electric Railway Company incorporated at \$150,000, by George L. Nichols, George M. Huyett, William M. Tobias and Henry R. Newkirk, of Brooklyn; Harry C. Norton, B. B. Odell, Jr., Joseph M. Dickey, Wilbur H. Weston and William D. Dickey, of Newburgh. Road to be operated by July 4.

NEW YORK CITY.—The Long Island Electric Railway Company is incorporated, by Alex. R. Hart, Brooklyn; Chas. H. Mullin, Mount Holly Springs, Pa.; Chas. M. Cooper, G. W. Miller, Wm. H. English, et al., of New York; Clarence, Benjamin and Edwin Wolf, of Philadelphia; capital, \$600,000. Office at Fairport, Queens County, N. Y.

CANANDAIGUA, N. Y.—The consolidation of the Canandaigua Street Railway Company and the Canandaigua Electric Street Railway Company has ceased operation of horse cars and will equip entirely with electricity this spring. President, M. D. Munger; superintendent, C. J. Purdy.

NEW YORK CITY.—The Nassau Electric Railway Company of Brooklyn has let contract for 100 miles of city and suburban street railway. One half is to be completed by July 15. R. T. Wilson of New York, Congressman Tom Johnson and A. L. Johnson of Cleveland, and P. H. Flynn of Brooklyn are the principal capitalists interested in the new railway. W. A. Boland, of Boston, has the contract.

### North Carolina.

RALEIGH, N. C.—The Raleigh Street Railway Company will be sold at auction at the U. S. postoffice at Raleigh, April 14, 1894, to satisfy the Mercantile Trust & Deposit Company, of Baltimore. For particulars, apply to R. T. Gray, commissioner, Raleigh.

### Ohio.

AKRON, O.—The Akron & Cuyahoga Falls road has resumed construction.

TIFFIN, O.—Tiffin Electric Railway will probably extend to Port Clinton this summer.

JEFFERSON, O.—Stevens & Kinney, of Windsor, are here in the interests of the proposed Jefferson-Conneaut line.

DAYTON, O.—The City Railway Company has just purchased a site on the west side, on which it will erect a central electric power-house.

UTICA, N. Y.—Gentlemen interested in Utica belt line are considering a road to connect Utica with Oriskany.

WARREN, O.—W. H. Rosensteel has resigned his receivership of the Mineral Ridge & Niles Electric Railway, and W. H. Smiley is appointed in his place.

IRONTON, O.—Engineer R. T. Graves writes Superintendent Johnson, of the Ironton Railway that work will begin immediately on the Electric line here.

TOLEDO, O.—A new electric railway applies for right-of-way. Men interested are: J. H. Ainsworth, J. Ellery Eaton, W. G. Gardiner, J. A. Bick and J. A. Dawson.

TOLEDO, O.—The Toledo, Maumee & Perrysburg Electric Railway is incorporated at \$150,000, by J. K. Tillotson, Frank M. Ohl, Dustin Atwood and Norman McCarty.

CLEVELAND, O.—The Cleveland Moto Company is incorporated at \$36,000, by G. D. Breck, E. R. Kelly, C. L. Saunders, F. I. Kuhn and F. L. Carter, to manufacture motors, cars, etc.

VERMILLION, O.—Mayor Cummings, H. S. Carter, Judge Steele and John Randolph, of Oberlin, have been here on business pertaining to the proposed Wakeman-Vermillion-Oberlin line.

YOUNGSTOWN, O.—Youngstown & Canfield Street Railway Company elects directors: J. H. Shields, W. P. Arms, J. W. Canfield, Samuel Ewing, John Delfs, John Fink and J. Cal Ewing.



CLEVELAND, O.—The Ohio Interurban Railroad Company is incorporated by James L. Saunders, Frank J. Lewis and William C. Scorer at \$200,000. It will build and equip street railways.

AKRON, O.—E. L. Babcock and T. F. Walsh of Cuyahoga Falls have been granted rights to extend the Akron-Cuyahoga Electric Railway into this city. The line will now be rapidly pushed.

YOUNGSTOWN, O.—A settlement was reached yesterday afternoon in the street car strike. The men agree to go to work at the old rate of wages, and will hold another conference soon to readjust the scale.

CINCINNATI, O.—Postmaster Hetch and the South Covington & Cincinnati Street Railway Company have agreed that the railway shall become a mail route.

AKRON, O.—Hon. Martin Dodge, Cleveland; H. S. Gray, Cleveland and General Hurst, of Chillicothe, are pushing the Cleveland-Akron Electric Railway.

TOLEDO, O.—The United States government has made a contract with the Robinson lines, whereby the mails may be carried on its cars. A mail car is in prospect.

MARION, O.—E. Durfee, E. Huber, Geo. Turner, Henry Strelitz, S. E. Barlow, and Godfrey Leffler, all of Marion, want a street railway franchise here, and intend to build this season.

CINCINNATI, O.—The Cincinnati Street Railway has bought site for its new power house, for which Engineer Bert Baldwin already has drawn plans. The house and equipment will cost \$250,000.

CINCINNATI, O.—There is a report that the Consolidated will build a line to the "Zoo" outright, in case the Mt. Auburn cable cannot be purchased. President Kilgour says that the line to Madisonville will be in operation by September 1st. It will be double tracked all the way.

NORWALK, O.—The Sandusky, Milan & Norwalk Electric Railway directors have decided to extend the West Main street line. Treasurer's report shows for past six months: Operating expenses, \$13,204; earnings, \$16,573; capital stock, \$100,000; bonds, \$100,000.

MADISONVILLE, O.—The local syndicate has made application for franchise here. The men are: Chas. S. Muchmore, W. H. Settle, Chas. L. Letz, Geo. W. Losh, and Jas. Julien. Franchise asked for 25 years and double track.

YOUNGSTOWN, O.—The stockholders of the Canfield & Youngstown Electric Railway have elected the following board of directors: J. W. Canfield, W. P. Arms, S. O. Ewing, John Delfs, J. C. Ewing, John Fink, J. H. Shields, H. M. Osborn, and Allen Calvin.

DAYTON, O.—Dayton Traction Company is chartered to build electric line from Dayton to Cincinnati. Capital stock \$500,000. The incorporators of the company are Judge Dwyer, O. B. Brown, William A. Mays, Frederick Retbald, Oscar M. Gottschalk, William Huffman and Walter Smith.

TIFFIN, O.—The Tiffin & Interurban Consolidated Street Railway Company is the name of the consolidation of the Tiffin Street Railway Company, the Tiffin Electric Railway Company, and the Tiffin-Fostoria Electric Railway Company. The understanding between the companies is now complete and the following officers are elected: President, R. W. Brown; vice president, Amandus Betts; secretary, N. W. Miller; treasurer, T. T. Rosendale, all of Tiffin except the last.

## Oregon.

OREGON CITY, ORE.—Oregon City Manufacturing Company wants to build a street railway line.

PORTLAND, ORE.—George Lumsden resigns superintendency of the Albina lines of the City and Suburban, and Superintendent L. McCoy, of East Portland lines, takes his place.

SALEM, ORE.—The Salem Motor Railway Company contemplates the extension of its electric line north on Broadway to the Polytechnic Institute in Highland addition.

PORTLAND, ORE.—The Portland Traction Company has been organized at San Francisco to operate street railroads in this city. Only one Portland man, Thomas N. Strong, is on the directorate. The directors are Isaac Hecht, S. Prentiss Smith, Frank L. Brown, S. Schwabacher and Thomas N. Strong. D. O. Mills holds \$129,000 worth of subscribed stock as trustee. Charles H. Ahearn holds \$22,000 in like manner. The capital is \$400,000, three-fourths of which is subscribed. The company is said to be composed of the bondholders in the Portland cable.

## Pennsylvania.

PITTSBURG, PA.—The North End Passenger Railway has its ordinance passed.

ALLEGHENY, PA.—Mayor Kennedy has signed the ordinance giving right of way to the Sharpsburg, Millvale & Etna Electric Railway.

BRISTOL, PA.—The Trenton & Bristol road has purchased an old mill at this place for a depot and power house.

FRANKLIN PA.—The Franklin Street Railway, to be built this spring, had been granted the right to use T rails on the streets.

WEST CHESTER, PA.—West Chester & Downingtown Electric Railway is bought by a syndicate represented by James McGraw.

EASTON, PA.—The Easton Transit Company has let contract for extension to the Chain Dam to the Lehigh Valley Construction Company.

SCRANTON, PA.—General Manager Archer says the Scranton Traction Company will adopt fenders and equip all cars within three months.

CHESTER, PA.—The Chester Traction Company applies for a charter Eugene Harvey, George Potteiger, Charles F. Wagner, Col. S. A. Dyer and William Wilson are interested parties in the new corporation.

CARLISLE, PA.—The Cumberland Valley Traction Company has let its contract for a power house to the Harrisburg Foundry & Machine Company.

READING, PA.—The highway committee grants the Reading Traction Company a number of extensions and connections with the Never-sink Mountain line.

PITTSBURG, PA.—Work on the Pittsburg & Mansfield Electric Railway, ordinance for which has been granted, will begin soon. A bridge across the the Monongehela will be built.

PHILADELPHIA, PA.—Stern & Silverman, of this city, are awarded the contract for rebuilding the Brigantine Traction Company's Railway at Brigantine Beach, opposite Atlantic City, N. J.

PHILADELPHIA, PA.—It is now decided that the Hestonville, Mantua & Fairmount Passenger Railway Company will erect an electric plant. The stockholders authorize \$750,000 in thirty-year 5 per cent bonds.

ALLEGHENY, PA.—The Federal Street & Pleasant Valley Traction Company will build the North End Passenger Railway, three miles, this summer; suburban line, T rail.

MANAYUNK, PA.—The Manayunk-Roxborough Inclined Plane & Railway Company has been granted trolley rights. It will operate along Ridge avenue, from the Philadelphia & Reading to the county line.

LOCKHAVEN, PA.—Lockhaven Street Railway Company elects J. B. Myers secretary and treasurer. The secretary will try to secure charter of the old Lockhaven Street Railway Company and whatever rights still remain.

PHILADELPHIA, PA.—Philadelphia Elevated Railway Company incorporates at \$42,000. Directors are: Walter N. Boyer, Radcliff B. Mills, John R. Bowman, Samuel R. Russell and David McKee, all of Philadelphia.

FOREST CITY, PA.—The officers of the Forest City branch of the Lackawanna Valley Passenger Street Railway Company are: William Walker, of Mayfield, president; J. R. Fleming, J. J. Walker and J. D. Caryl, of Forest City, directors.

**CHESTER, PA.**—The Chester Traction Company has consolidated the Chester Street Railway, the Chester & Media, the Chester-Darby & Philadelphia and the Union Railway. Col. S. A. Dyer, president of the Union Railway, is at the head of the syndicate.

**HARRISBURG, PA.**—Charters have been granted to the Athens & South Waverly Railroad Company, of Bradford County; length of line, four miles; capital stock, \$40,000. The Hanover & Newport Railroad Company, of Luzerne County: length of line, ten and one half miles; capital stock, \$500,000.

**CHESTER, PA.**—Capt. S. A. Dyer, of the Union Street Railway, has succeeded in consolidating the street railways of this city, and as soon as the charter is obtained the Chester Street Railway, the Union, the Chester & Media and the Chester, Darby & Philadelphia companies will be merged under one management, to be known as the Chester Traction Company, with a capital stock of \$500,000. Capt. Dyer will be manager. New connecting lines will be built.

**PITTSBURG, PA.**—The Allegheny city council committee on corporations ordered three street railway ordinances printed. The first grants the North End Passenger Railway Company rights to run an electric railway continuing the Charles street line; two, the Pittsburg Union Passenger Railway Company and the Pittsburg, Allegheny & Manchester rights to build to Watson Park and return; three, grants the Millvale, Etna & Sharpsburg Street Railway Company right to pave with Belgian block, and so removes obstacle to construction.

### South Carolina.

**COLUMBIA, S. C.**—The Land & Electric Railway Company is drawing up contracts for an extension of the line to the suburb of Kleinbeck, a summer resort. Extension to be finished by June.

**COLUMBIA, S. C.**—Electric Street Railway & Land Investment Company has decided to lay out a suburban town to be called Kleinbeck Park, and extend the street railway thereto, adding summer attractions of various sorts. It is to be completed in two months.

### Tennessee.

**NASHVILLE, TENN.**—The United Electric Railway will be sold at auction at the U. S. Custom House, April 18.

**NASHVILLE, TENN.**—Receivers have asked for the appointment of day and conditions for sale of the United Electric Railway Company.

**KNOXVILLE, TENN.**—It is reported that Receiver Duncan, of the Knoxville Electric Street Railway, will soon be ousted and the road re-organized after being sold. H. S. Morse, attorney for the Thomson-Houston Company, is consulting local attorneys to that effect. The Thomson-Houston holds large claims and first lien.

### Texas.

**RAVENNA, TEX.**—John A. Russell will probably extend his Bonham dummy line to the fair grounds here, seven miles.

**FT. WORTH, TEX.**—S. R. Williams, general manager of the Ft. Worth Gazette, wishes to buy a second hand 500-volt street railway motor.

**HOUSTON, TEX.**—A. Christenson, Wm. G. Wilson and E. W. Cave incorporate the Houston & Suburban Street Railroad Company, at \$100,000.

**DALLAS, TEX.**—Major Ewing, Superintendent of the Oak Cliff Railway, says that his road will be changed to electricity this summer. St. Louis Trust Company owns the line.

**FT. WORTH, TEX.**—T. A. Hall, Memphis, Tenn. is here representing an eastern syndicate for the acquirement of various street railway plants in the State.

**DENISON, TEX.**—On application of J. J. Fairbanks, R. S. Legate is made receiver of the Denison Street & Belt Line Railway Company, and the Land & Investment Company.

**DALLAS, TEX.**—Incorporated: The Dallas Belt Line Railway Company; capital stock, \$100,000. Incorporators, Wm. Shotka, A. T. Perkins, Chas. H. McDonald, Wm. H. Cothren, J. M. Witherspoon, F. G. Adamson, S. L. Terrell, Chas. C. Cobb, Thomas Scurry and J. M. Avery.

### Utah.

**OGDEN, UTAH.**—The Ogden & Brigham City Railway Company incorporates. Officers: J. C. Sprunt, president; E. Reed, vice-president; J. C. McCoy, treasurer, and George F. Phillips, secretary; these, together with Mark L. Fletcher, constitute the board of directors. It is to be an extension of the motor line.

### Virginia.

**RADFORD, VA.**—Radford Street Railway Company, M. A. Riffe general manager, will operate electric, May 1.

**RICHMOND, VA.**—Richmond City & Seven Pines Railroad is sold to George E. Fisher, of the Richmond City Electric Railway, for \$50,000. Line is seven and a half miles long.

**RICHMOND, VA.**—The Virginia Electrical & Railway Company, chartered at the last session of the legislature to carry on electric railway enterprises, wants a franchise to build on Broad street to the fair grounds. This includes the building of a viaduct. The company's officers are: John C. Robertson, president; E. A. Catlin, secretary; R. H. Smith, treasurer, and E. T. D. Myers, Jr., engineer in charge.

### Washington.

**SPOKANE, WASH.**—The Spokane Street Railway Company has had its franchise over Front avenue and Post street granted for electric freight hauling privileges.

**SEATTLE, WASH.**—W. J. Grambs has been appointed receiver of the Ranier Avenue Railroad Company at request of C. E. Cotting, Charles S. Tuckerman, F. G. Webster, et al. Indebtedness, \$45,000.

### West Virginia.

**NORFOLK, W. VA.**—The council has granted extension privileges to the City Railway.

**WHEELING, W. VA.**—Organized: The Bluefield Electric Railway Company, to run from Bluefield to Graham, Va., principal office at Bluefield, W. Va. Capital, \$20,000.

**CHARLESTON, W. VA.**—Philadelphia capitalists have organized the Bluefield Electric Railway, which proposes to build a twenty mile freight and passenger electric in the Bluefield coal region.

**KENOVA, W. VA.**—The Kenova Railway Company is incorporated by L. T. Peck, of Kenova, and J. M. Wirginan, W. H. Triol, J. W. White and F. M. Halsley of Philadelphia. The company will construct and operate a street railway or a dummy line from Ceredo to the mouth of the Big Sandy river.

### Wisconsin.

**LA CROSSE, WIS.**—La Crosse & Onalaska Street Railway Company increases capital from \$30,000 to \$50,000 and will use electricity on proposed line.

**ONALASKA, WIS.**—General Electric Company, Chicago, has contract for the Onalaska Street Railway Company's plant. James Canterbury is manager.

**KENOSHA, WIS.**—F. M. Kringle wants to build a street railway line here. He has built lines in Dubuque, Ia., and seems willing to risk a line in Kenosha.

**MILWAUKEE, WIS.**—Vice-president Payne and a committee of citizens agree on a plan to build the Prospect Hill line by July 1, one mile long. A cash bonus of \$5,000 is guaranteed.

### Canada

**TORONTO, CAN.**—Hunter & Hunter, barristers, on behalf of a syndicate, ask for rights to build an electric railway on the island. They claim that the syndicate has plenty of money, and will begin at once.

**MONTREAL, CANADA.**—Montreal, Park & Island Railway Company has decided to build the Notre Dame de Grace line and the road to St. Vincent de Paul. Hon. Louis Beaubien is elected president, and J. R. Thibaudeau vice-president.

**BRISTOL, ENGLAND.**—The Bristol Tramway Company has secured permission to build an electric road on the trolley system.

THE ELECTRICAL MACHINERY OF THE WALKER MANUFACTURING COMPANY.

The announcement several months ago that the Walker Manufacturing Company, of Cleveland, would start an electrical department, caused a profound sensation, as it was known that if this company undertook this class of work it would be done on an extensive scale. The electrical public has therefore been waiting with interest

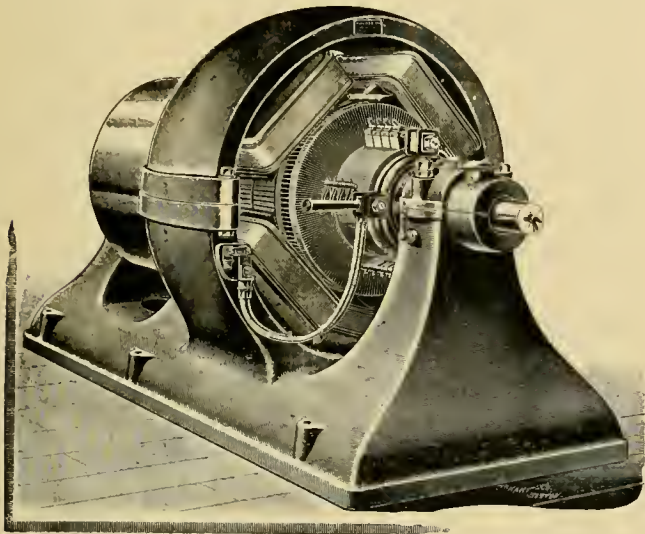

WALKER MULTIPOLAR GENERATOR.

for further announcements as to the particular form of the machinery to be manufactured. The Company now is on the market with direct and alternating current generators of from 150 to 500 horse-power at from 500 to 10,000 volts, and motors to correspond. It is unnecessary to enlarge on the facilities of this concern for handling heavy machinery as they have been previously described

are wrought iron. The armature has no windings or binding wires on its surface, and there are no joints in the windings except at the commutator. The two circuit winding is used so that the circuits can not be thrown out of balance by a change of the relative distances of the

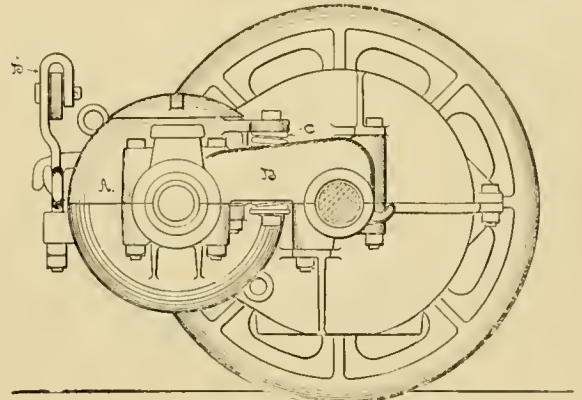

METHOD OF MOTOR SUSPENSION.

pole pieces. Armature and commutator are thoroughly ventilated.

The street railway motor while appearing at first glance very similar to those already in use is seen on closer

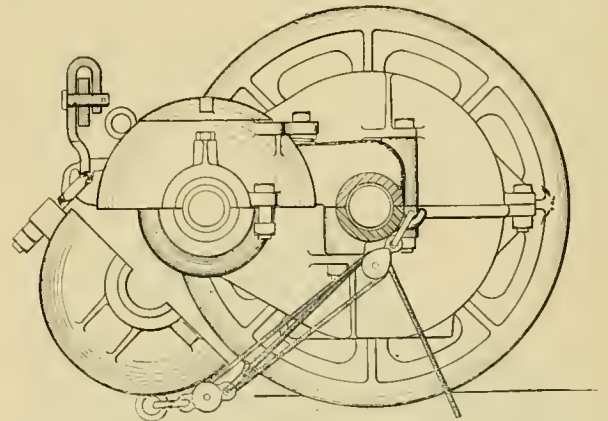

METHOD OF OPENING MOTOR.

inspection to be radically different in a few important particulars. In the first place the motor is so suspended as to have practically no rigid connection with the axle. This method can only be understood by a look at the

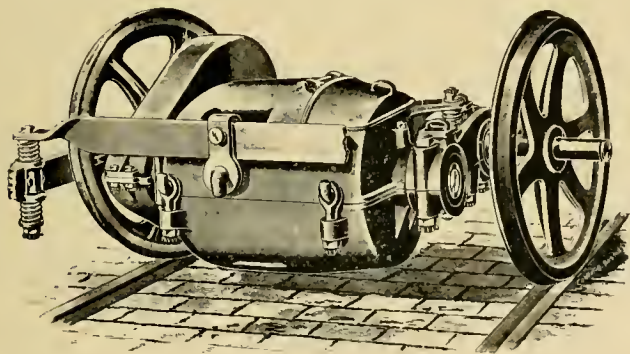

WALKER STEEL RAILWAY MOTOR.

in our columns. Iron galleries have been fitted up at either end of the three long bays, of which the factory is composed, for winding and manufacturing insulating material. In the large foundries adjoining, fifty tons of iron can be handled at one time and consequently their large machines can be cast in few parts. This is well illustrated by their 250-horse-power, four pole generator which is seen to have but two parts to the frame. The bearings are self oiling and self aligning. The field cores

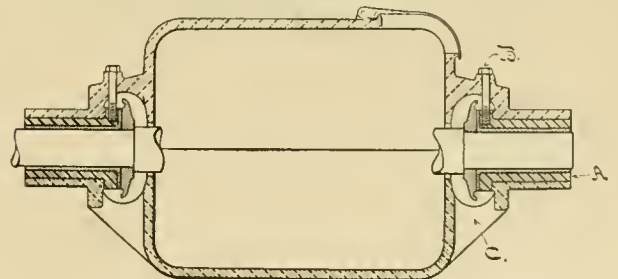

SECTION THROUGH MOTOR CASE AND BEARINGS.

illustrations. The motor shaft is kept parallel with the car axle by a frame of which the gear case forms a part. This frame has bearings on the outer ends of the motor axle but is not connected with the motor case so that the motor proper is free to turn independently of the frame.

The motor is held in place by springs. Thus the motor is flexibly suspended as far as weight on the tracks is concerned. It is of steel, (four pole type) and rated at 25 horse-power. The weight of the motor proper is but 1,200 pounds, and the complete machine 1,600 pounds. Series-parallel controllers are used and the maximum speed of the motor is 25 miles an hour. That the designer was a practical man can be seen by the excellent provisions made for the taking apart of the motor. Both the upper and lower halves can be easily removed and a

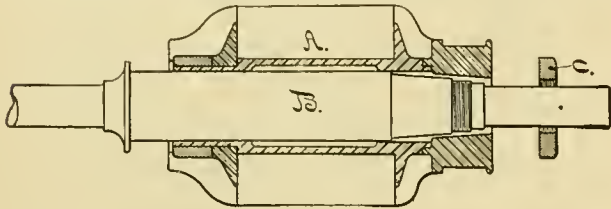

SECTION THROUGH AXLE AND CORE.

lid is provided over the commutator. The armature can be removed from below or above. When closed the motor is entirely dust proof. The bearings are outside of the motor casing as is shown in the longitudinal section through the case. A space is left open between the bearings and case into which the grease works and falls to the ground through an opening in the bottom which is so large that it cannot be clogged. In the section, A is the shell filled with babbitt and held from turning by the bolt B. The armature is a drum with two circuit winding. The armature core and commutator are built on a sleeve,

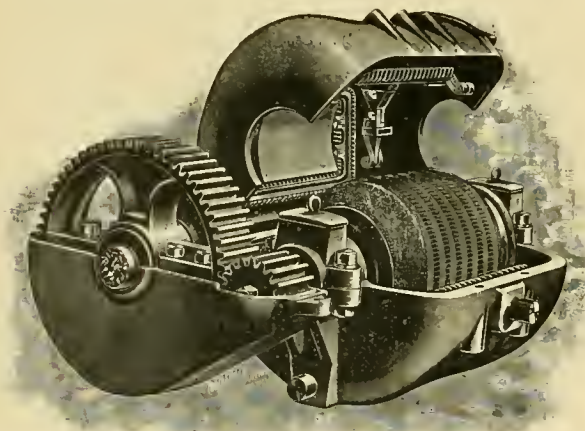

WALKER CAST IRON MOTOR.

so that by removing one nut, (C. in the longitudinal section of the armature) the shaft can be taken out without disturbing the armature. The commutator is on a tapered part of the sleeve and can easily be drawn off. Besides this motor another one of cast iron rated at 35 horse-power and weighing 2,500 pounds is made for heavy work. It is not flexibly suspended. Designs are completed for large motors for operating suburban and elevated trains at high speed.

The apparatus is certainly all of remarkably ingenious design and with the quality of its workmanship the Walker factory finds a ready market for its output.

**STREET RAILWAY PATENTS.**

Compiled by The Street Railway Review.

ISSUED MARCH 6, 1894.

Electric switch signal. Thos. L. Dalton and Nelson W. Dalton, Sandy Hill, N. Y. ....515,751  
 Strain insulator. Henry H. Luscomb, Hartford, Conn, assignor to the John Pratt Company, same place .....515,779  
 Street car fender. Randolph C. Lothrop, Somerville, Mass .....515,868  
 Fare register. Edward T. Taylor, Oakland, Cal. ....515,888  
 Hanger for trolley wires. George Forbus, Williamsport, Pa. ....515,907  
 Street or station indicator. Bernard Barnett, New Orleans, La. ....515,929

ISSUED MARCH 13, 1894.

Electric railway. Mark W. Dewey, Syracuse, N. Y., assignor to the Dewey Corporation, same place .....516,188  
 Street car fender. Thomas Davies, Toronto, Canada .....512,266  
 Wagon railroad. Thomas M. Galbreath, Memphis, Tenn. ....516,327  
 Closed conduit electric railway. Frederick S. King, Chicago .....516,374  
 Electric trolley device. Charles P. Knapp, St. Louis, Mo., assignor to Ashton G. Bean and Herbert O. Rockwell, same place .....516,492  
 Sanding device for cars. John Ballard, Boston, Mass, assignor one half to Thomas W. Berry, same place .....516,515  
 Electric motor for street cars. William Baxter, Jr., Baltimore, Md. ....516,516  
 Electric railway supply system. James F. Cummings, Detroit, Mich., assignor one half to Eugene M. Engleman, Milwaukee, Wis. ....516,565  
 Closed conduit electric railway. Edward H. Brown, Salem, assignor to the Magnetic Electric Company, of West Virginia, Boston, Mass. ....516,626  
 Closed conduit for electric railways. William Lawrence, New York, N. Y., assignor to the Lawrence Electric Company, same place. ....516,631

ISSUED MARCH 20, 1894.

Electric railway system. Elihu Thompson, Swampscott, Mass., assignor to the Thomson-Houston Electric Company, of Connecticut. ....516,666  
 Track cleaner. John W. Warren, Sydney, New South Wales. ....516,714  
 Electric railway switch. Charles M. Fitch, South Norwalk, Conn., assignor to the Fitch Excelsior Switch Company, New Jersey .....516,731  
 Awning or curtain for cars. Edward T. Burrowes, Portland, Me. ....516,762  
 Car truck. Norman C. Bassett, Lynn, Mass., assignor to the Thomson-Houston Electric Company, of Connecticut .....516,791  
 Block system for electric railways. John W. Gibboney, Lynn, assignor to the General Electric Company, Boston, Mass. ....516,806  
 Overhead electric railway. John C. Henry, Westfield, N. J. ....516,808  
 Electric motor. Walter H. Knight, Lynn, assignor to the General Electric Company, Boston, Mass. ....516,818  
 Series-parallel controller. Edward D. Priest, Lynn, assignor to the General Electric Company, Boston, Mass. ....516,834  
 Conduit for electric railways. Herluf A. Petersen, Milwaukee, Wis. ....516,876  
 Street car. Peter M. Kling, St. Louis, Mo. ....516,934

ISSUED MARCH 27, 1894.

Electric railway trolley. Frank S. Church, Detroit, Mich., assignor of one half to William F. H. Edwards, same place .....517,028  
 Sanding device for cars. Clarence E. Holbert, St. Joseph, Mo. ....517,044  
 Railroad rail and chair and process of uniting same. Maximilian M. Suppes, Johnstown, Pa., assignor by mesne assignments to the Johnson Company of Pennsylvania. ....517,075  
 Apparatus for supplying or removing storage batteries. William E. Worthen, New York, N. Y. ....517,134  
 Trolley catcher. Levi G. Mowry, Buffalo, N. Y. ....517,166  
 Electrical railway. Benson Bidwell, Philadelphia Pa, assignor one half to Charles F. Bidwell, Indianapolis, Ind. ....517,258  
 Railway track structure. Peter Hevner, Philadelphia, Pa. ....517,277  
 Safety guard for open cars. William H. Hart, Chelsea, Mass. ....517,339  
 Ratchet for car brake staffs. August D. Gerbig, St. Louis, Mo., assignor to the Laeclde Car Company, same place. ....517,405



THE SIOUX CITY ENGINE and Iron Works have resumed work with a force of 200 men.

HERBERT McNULTA has been appointed superintendent of the Calumet Electric Railway of Chicago.

J. W. PARKER & Co., agents for the Ball engine, have removed from 18 to 30 Cortlandt street, New York.

THE WALLACE ELECTRIC COMPANY has secured quarters in the Manhattan building, 307 Dearborn street, Chicago, and will remove there May 1.

THE GOUBERT MANUFACTURING COMPANY, of New York, is mailing on request a valuable pamphlet on "Dry Steam the Foundation of Economy."

THE SIEMENS & HALSKE ELECTRIC COMPANY of America are building generators to the extent of 3,000-horse-power for the Toronto Street Railway.

THE LACONIA CAR COMPANY, Laconia, N. H., has contracted to furnish the West End Street Railway, of Boston, with 150 trucks of the Laconia pattern.

THE GOUBERT MANUFACTURING COMPANY announces a change of its New York office from 32 Cortlandt street to 14 and 16 Church street, corner of Cortlandt.

THE SHULTZ BELTING COMPANY, St. Louis, has a large number of domestic and foreign orders. One from Russia calls for 10,000 feet and one from India 3,500.

THE BERLIN IRON BRIDGE COMPANY, of East Berlin, Conn., is constructing a large iron roof for the new car barn of the Colonial Electric Railway at Kingston, N. Y.

THE BERLIN IRON BRIDGE COMPANY is to make the roof for the new car barn of the Colonial Street Railway, of Kingston, New York. Its orders for bridges are very numerous.

THE MCKAY CURTAIN COMPANY, of Wilmington, Del., is becoming rapidly well known to the street railway field. Its railroad business is one of the largest in the country.

THE MATHER ELECTRIC COMPANY, of Manchester, Conn., has appointed S. N. Blake, of Elmira, N. Y., contractor Mather apparatus in northern and western New York State.

F. S. PIERSON, formerly of the West End, of Boston, succeeds Major McNulty, who will hereafter be engaged in the construction work of the Columbus & Ninth Avenue line, New York City.

THE OKONITE COMPANY, 13 Park Row, New York, has given out a dainty desk clock enclosed in glass to signify to its friends that time has no effect on the quality or quantity of okonite cable.

THE Consolidated road, at Grand Rapids, Mich., has introduced one of the Jogada furnaces in their power plant with excellent results in consumption of smoke and reduction of amount of fuel used.

THE FULTON FOUNDRY & MACHINE WORKS, 21 Furman street, Brooklyn, N. Y., is doing a good business. E. B. Willcox has reorganized the casting department and has a good basis to begin work.

THE STERLING SUPPLY & MANUFACTURING COMPANY, of New York City, has moved into new and commodious quarters in the Ross building, corner of Hudson and Bank streets, where its shops are situated.

THE LACLEDE CAR COMPANY, of St. Louis, is distributing an elegant morocco-bound catalogue of the most modern types of car bodies manufactured by it. No less than twenty-five styles are illustrated and described.

THE ELECTRICAL AND MECHANICAL ENGINEERING & TRADING COMPANY, 39 Cortlandt street, New York City, is the new address of this well-known company, which formerly held offices in the Edison building, 44 Broad street.

THE WESTINGHOUSE ELECTRIC & MANUFACTURING COMPANY has secured one of the largest orders in a long time, being 150 motor car equipment for the West End Street Railway, of Boston. This was secured through Lemuel Bannister.

HORACE E. ANDREWS, president of the Cleveland Electric Railway Company, and of the Cleveland General Electric Company, has been appointed a member of Gov. William McKinley's military staff, to succeed Col. Myron T. Herrick.

JACKSON & SHARP, Wilmington, Del., have taken large orders for cars from the Derby Street Railway Company, Derby, Conn., Hartford, Conn., Philadelphia, Pa., and Pottstown, Pa. They report a large number of inquiries and a bright outlook for trade.

B. J. ARNOLD, consulting engineer, has removed from 565 Rookery to 463 in the same building. This gives more space for the growing business of the different members of the "happy family," of which Fred De Land is the senior representative.

G. F. STAMBAUGH, succeeds George B. Merrill as Chicago and western representative of the Falls Rivet & Machine Company, of Cuyahoga Falls, O., with offices at 10 South Canal street. The western branch is known as the Chicago Shafting & Pulley Company. Mr. Stambaugh, has an intimate knowledge of trade, having been for some time connected with the Chicago branch in another capacity.

A BIG shaft, weighing 111,800 pounds, was recently shipped to Brooklyn, N. Y., by the E. P. Allis Engine Company of Milwaukee. The Pennsylvania Company's gun truck was used, the same which transported the great Krupp guns to the World's Fair.

THE annual meeting of the Short Electric Railway Company, of Cleveland, resulted in the re-election of the old board of directors and the following officers: President, B. F. Miles; secretary and treasurer, Bethune Duffield; S. M. Hamill, general manager.

GENERAL MANAGER MIX, of the Rice Machine Company, 166 South Clinton street, Chicago, has issued one of the most attractive little volumes containing eighty World's Fair views which he will mail to any address on receipt of four cents in stamps to cover postage.

THE first annual dinner of the Boston West End Street Railway Association was held March 15. John H. Dudley, Jr., presided. Paul Winsor spoke on transportation in Paris, and other good speeches were made. Employees of the company in attendance numbered 120.

MCINTOSH, SEYMOUR & Co., have put three 700-horse-power engines in the Ridgewood power station. Three more are to go to the City & Suburban Railway of Baltimore and four to the Cincinnati Street Railway. This company seems to be getting its full share of railway business.

THE NATIONAL WATER TUBE BOILER COMPANY of New Brunswick, N. J. has erected a plant of national boilers, amounting to 2,500 horse-power for the Ohio Steel Company at Youngstown. The boilers from the World's Fair will also be used, making the plant of 4,000 horse-power.

THOMPSON'S scenic railway at the Midwinter Fair has already carried 200,000 passengers, and as high as 15,000 in a single day. It is one of the three types switchback, gravity cable, and serpentine, invented by L. A. Thompson, several of which are already in use at street railway pleasure resorts.

ABOUT 150 invited guests assembled on Saturday, March 31, at the works of the Ball & Wood Company, Elizabeth, N. J., to witness the first operation of their new vertical engine for electric work. The occasion was a successful and delightful one in every way, and a fine lunch was served.

WESTINGHOUSE, CHURCH, KERR & COMPANY have removed their New York office from 17 Cortlandt street, to the Havemeyer building. The new quarters, on the sixth floor, comprise four rooms and a connecting hall, elegantly furnished and fitted. They report a large number of late orders.

B. W. PAYNE & SONS of, Elmira, N. Y., have recently closed a contract for the complete power equipment of the Middletown-Goshen Street Railway, of Middletown,

N. Y. Two Payne improved Corliss engines of 100-horse-power each and two 125-horse-power horizontal tubular boilers will be used.

THE SAFETY BRAKE SHOE COMPANY, of Boston, reports so great an increase in sales that another foundry has been started to keep up with the demand. Western connections are contemplated for the near future. Many prominent roads have adopted the shoe, and further popularity is but a matter of time.

THE BALL ENGINE COMPANY, of Erie, Pa., shows among recent shipments of its well-known engines, seven hundred horse-power for various public buildings in various parts of the country. Two hundred horse-power will be used in the Criminal Court building at Chicago, and one hundred in the House of Correction.

THE GRAHAM EQUIPMENT COMPANY sends out a postal card which bears a section of the Carnegie I beam used in the frame of the new Graham truck especially designed for long 10-bench, 30-foot open cars. This beam has a coefficient of 67,000 pounds to the foot, has a  $\frac{3}{8}$ -inch web, is five inches high, and makes an extra sill for the car body and prevents "hogging."

THE JEWETT CAR COMPANY, of Jewett, O., has several orders to report this month. Among them are four 34-foot open cars for the Brigantine Traction Company, of Brigantine Beach, N. J., office at Philadelphia; and four 18-foot vestibule cars for the Middletown-Goshen Traction Company, of New York, besides five smaller orders. The Jewett Company is meeting with deserved success.

AMONG recent sales of the Bates Machine Company's well known engines may be mentioned the following: Three 100-horse-power at Kansas City, Mo.; one 100 to San Antonio, Tex.; one 125 to Richmond, W. Va.; one 300-horse-power at Milwaukee, Wis.; one 150 at Philadelphia, and a 1,000-horse-power compound to DeKalb, Ill. The Bates engine is a superior machine and its success is deserved.

SPEAKING of business these days a prominent western engine builder says: "We cannot see much of an improvement in our business over that of the past six months, although inquiries seem to be a little more frequent and the actual contracts entered into are of a less experimental nature than usual. Such parties as are now engaging in business are in earnest and seem to feel assured of success in their ventures."

GEORGE B. MERRILL, formerly of the Falls Rivet & Machine Company's Chicago management, has entered the power transmission field for himself, and has taken quarters at 42 South Clinton street, as manufacturer and dealer in all kinds of machinery pertaining to power transmission of power. Mr. Merrill is well-known to the trade, and will be, naturally, as successful in his new connection with trade as of yore.

THE MCGUIRE MANUFACTURING COMPANY, of Chicago, has shipped to the Third Avenue Railway Company, New York, a carload of their steel frame grip trucks. These trucks are designed to carry the car body 24 inches from the rail, and have a 9-inch wheel base with a 17-foot, 8-inch spring base. In other words, the spring base is within 6 inches of being double the wheel base, which is certainly an extraordinary construction.

J. HOLT GATES, western manager of the Waddell-Entz direct coupled dynamos and motors, has taken the western contractorship for the Mather Electric Company of Manchester, Conn., belt driven railway and light generators and motors. Mr. Gates celebrated his new connection by selling two 500-light dynamos on the first day. He will do a general electrical contracting business also, with headquarters at 1139 and 1140 Monadnock Block, Chicago.

CLIFT WISE, of the Complete Electric Construction Company, 1401 Monadnock, Chicago, is at work on the promotion of a road up the Rock river between Rockford and Dixon, Ill. When completed it will be 40 miles long, deriving its power from water-power plants along the river. It seems to be a good location both from a scenic and commercial standpoint, as Rock river is the Hudson of the west. J. S. Ticknor of Rockford is president of the company.

THE GENETT AIR BRAKE COMPANY has just shipped an air brake equipment for the Kings street cable system, of Sydney, Australia. The company is also filling an order for the Chicago & North Shore Electric Railway Company, and an additional order for the Buffalo Street Railway Company. The success of the Genett brake has been of the most positive and encouraging character and Manager Rothschild has every reason to push further this successful air brake.

WARREN WEBSTER & CO., of Camden, N. J., manufacturers of Vacuum Feed Water Heaters and Purifiers and Oil and Steam Separators, report that the number of orders they received for the above-named specialties during the month of March was very satisfactory and showed a marked improvement over the few former months. Rapid progress is being made upon the new extension of their wrought iron department connected with the new works which they just built last year.

THE PENNSYLVANIA IRON WORKS COMPANY, of Philadelphia, has become sole licensee for the manufacture and sale of the Walker Patent Differential drums and friction clutches, for use in cable roads for the New England, Middle and South Atlantic states. The Walker's patents upon the efficiency of which so many cable roads have achieved success are too well-known to require other mention than that with such strong backing and efficient manufacture they will have increased usefulness.

THE LACLEDE CAR COMPANY, of St. Louis, Mo., report a full rush of work in all stages of construction. The Philadelphia Traction Company has an order in for 250 closed and open cars and a second call for 150 additional closed. These are to be mounted on Bemis trucks. The Cincinnati Street Railway Company has placed an order for 30 cars, 16-foot, besides a large grist of smaller orders from various parts of the country.

THE WESTINGHOUSE ELECTRIC & MANUFACTURING COMPANY has issued a new pamphlet describing the experiments which led up to the invention of the Wurts non-arcng railway lightning arrester. The Wurts device is suited to any direct current circuit, and sells for \$7.50 for the station arrester and \$4.50 for the car or line instrument. Its performance during the past season has been most creditable. Its claims are: simplicity, reliability and cheapness. The new pamphlet will be sent on application.

AHEARN & SOPER, of Ottawa, Canada, agents for the Westinghouse Electric & Manufacturing Company, have been awarded the contract for the electrical construction of the Gault & Preston, Canada, Electric Railway, as well as the cars. Goldie & McCulloch, of Gault, will supply the engines and boilers. Electric heaters will be used on the five cars, with which number the line will begin traffic. M. Hartnet, of Toronto, has the construction of the road bed and culverts. It is hoped that the line will be commissioned by May 24.

THE MCGUIRE MANUFACTURING COMPANY, of Chicago, is making two very peculiar pairs of trucks to go under the new welding machines of the Johnson Company. They are constructed to run on any gauge of track from 3 feet 6 inches to 5 feet 3 inches. The wheels are common 33 inch, with  $2\frac{1}{4}$  inch tread and  $\frac{3}{4}$  inch flange. The axle is threaded on the wheel-fit and the wheels are screwed on. The wheels can thus be easily adjusted to the gauge. The key ways are cut so as to give a quarter turn adjustment.

THE INTERNATIONAL REGISTER COMPANY, of 300 Dearborn street, Chicago, finding its present accommodations too small removed April 1, to much more commodious quarters, at 195-197 Canal street, where may be secured not only more space, but the most modern manufacturing facilities for the making of its well-known fare register. The factory is convenient to the central business district. The company reports a marked improvement in business, with a number of recent new contracts, among them the Chicago General Street Railway Company.

THE LYNN MANUFACTURING COMPANY, 620 Atlantic avenue, Boston, is a new concern making overhead equipment and supplies for electric railways. The factories are at Lynn, Mass., and the officers are: A. F. Hallbauer, president, and James C. Barr, treasurer. Both

these gentlemen are fully conversant with the peculiar needs of electric railways, and will market only the best material. The necessity of a well made and reliable overhead construction is one of the most important details of railway work, and the fraternity will watch the new firm with great interest.

THE ELSON & BREWSTER ENGINEERING COMPANY, New York representatives of the W. S. Hill Electric Company, of Boston, is a second time obliged to move into larger quarters, and can now be found at 143 Liberty street, New York, where with better facilities and larger stock, they are better prepared than ever to take care of a constantly increasing trade. The deserved success of the company is a matter of great satisfaction to the many friends of the management.

THE NEW YORK OFFICE of the Buckeye Engine Company, of which H. T. Porter is sales agent, removed April 1 from 18 Cortlandt street to 39 and 41 Cortlandt street, where larger and more commodious quarters will greet visitors, and in addition to the regular line the new vertical compound engines for railway and light service will be shown. The new engine has created something more than ordinary comment, and is particularly adapted for direct connection. Business at the Eastern office is considered to be on the increase.

E. J. SPENCER, who will be well and favorably remembered as in charge of the affairs of the General Electric Company at the World's Fair, has severed his connection with the General Electric Company, and has opened an office at 513 Security Building, St. Louis, where he will do a consulting and contracting electrical and mechanical engineering business. Mr. Spencer's nine years' experience in the electrical corps of the United States army and three years' special work at the Lynn factory of the General Electric, particularly qualify him for his new association.

A TELEGRAM to the REVIEW dated Cincinnati, March 19, brings the not unexpected news that another order of 75 Peckham standard trucks has been placed with the Cincinnati Street Railway Company. The recognition of the Peckham trucks by this conservative road is substantial, and shows that this line regards them as worthy of a large place in the economy of this excellent system. It may be stated further that P. S. Bemis was the missionary into Cincinnati who has wrought this work and added both to his own laurels and to the reputation of the Peckham Motor Truck and Wheel Company.

THE HALE & KILBURN, MANUFACTURING COMPANY, Philadelphia, has a house full of orders for street car seating. The Hale & Kilburn seat is to be used in 500 cars in Philadelphia and New York. A complete rattan spring seat is being made for 135 cars of the Philadelphia People's Traction Company. A plush covering will be drawn over it in winter, but removed

during the summer months. The Nos. 71 and 71½ reversible seats for electric cars are becoming very popular. They are made for plush, Wilton velvet carpet and other coverings, besides in rattan and elastic wood slat.

FISHER & PORTER, 1025 Monadnock Building, Chicago, report evidence of good business in the immediate future. They report a number of plants now in process of equipment, among them machinery for W. H. Roesle, of Pittsburg; a gold mine in Tennessee, and two 75-horse-power M. A. Green engines for the Leland Hotel, Chicago. The makers of these engines, the Altoona Manufacturing Company, of Altoona, Pa., report the works running full time with full complement of hands, and the Providence Steam Engine Company, maker of the Improved Green engine, also finds its factory full of work.

THE MCGUIRE MANUFACTURING COMPANY, has built within the last month seventy steel frame trucks for the Electric Traction Company, Philadelphia, fifteen for Memphis, Tenn., five for Davenport, Ia., twelve for the Cicero & Proviso Electric Railway, Oak Park, Ill., and they have orders yet unfilled from the Derby Street Railway, Derby, Conn., Buffalo & Williamsville Street Railway, Buffalo, N. Y., Philadelphia, Neville Island & Coraopolis Railway, Coraopolis, Pa., Hamilton, Grimsby & Beamville Railway, Hamilton, Ont., Sandusky, Milan & Norwalk Street Railway Company, Sandusky, O., Philadelphia & Delaware County Railway, Philadelphia, Pa., and others.

THE BUCKEYE ENGINE COMPANY, of Salem, O., reports trade lighter by far than for the corresponding period of last year. However, the Buckeye holds its own and reports show recent sales of two 300 horse-power, mediums, to the Richmond, Ind., Light, Heat and Power Company; 80 horse-power, medium, to the McKeesport & Wilmerding Street Railway Company; three 500-horse-power, tandem compounds, to the Dayton, O., Street Railway Company for direct connection with Siemens-Halske dynamos; one 600 horse-power medium speed cross compound to the Coplay Cement Company, Coplay, Pa., besides 17 other orders ranging from 25 to 150 horse-power to various other power users all over the United States.

### California in Three and One-Half Days.

If you are going to California and desire to make the journey in the most economical, quick and comfortable manner, purchase your ticket via the Chicago & Northwestern, Union Pacific and Southern Pacific Railways. Pullman drawing-room sleeping cars are run from Chicago to San Francisco without change, in three and one-half days. Completely furnished tourist sleeping cars are also run in which accommodations can be procured by passengers holding either first or second-class tickets at a cost of only \$4 per berth from Chicago to San Francisco and other California points. The hour of departure of trains from Chicago affords prompt connections with all trains from the east and south. Variable route excursion tickets, allowing nine months' stay in the health-giving climate of California, second-class tickets of low rates, sleeping car reservations and full information can be procured of any ticket agent, or by addressing W. A. Thrall, General Passenger and Ticket Agent, Chicago & Northwestern Railway, Chicago.



THE C. D. MORSE COMPANY'S CAR.

The accompanying illustration is a "song without words" concerning the beautiful car built by the C. D. Morse Car Manufacturing Company, of Millbury, Mass., for the Worcester, Leicester & Spencer Street Railway Company, of Worcester, Mass.

What the observer cannot see may be told in a few words of explanation as to dimensions and material. The car body is twenty feet long, with a 4-foot 1-inch platform inside of the dash. It is mounted on the well-known Bemis truck, and the Boston trolley, made by Albert & J. M. Anderson, is borne proudly above. The



Davis car shade, made by the Davis Car Shade Company, of Portland, Me., protects the passengers' eyes completely from the rays of the sun. The car is elegantly decorated inside and out and the white exterior denotes suburban service. It is, of course, unnecessary to state that every detail is of the best and most workmanlike design, and that the material is the most perfect procurable. Such is the method of the C. D. Morse Company, as many street railway men may testify.

The photograph from which our engraving was made was taken at Millbury, famous for its inventors and manufacturers, of which the Morse Car Company is perhaps most prominent.

OBITUARY.

WILLIAM H. GOODRICH,

treasurer of the Suburban Electric Railway Company, of Hartford, Conn., died recently. He was one of Hartford's best known citizens, a thirty-second-degree mason, and a prominent business man.

J. L. BARCLAY.

The fraternity learned with equal regret and surprise of the sudden death at the American House, Pittsfield, Mass., on March 26, of J. L. Barclay, of Barclay & McHarding. The cause of his death was an operation for appendicitis. Mr. Barclay was widely known as one of those earliest in the electric lighting field in the

east, and later as Chicago manager of the Westinghouse Electric Company, which position he assumed in 1888 and held until April, 1892.

For the following year he traveled and rested. Recently he joined with Mr. Harding for the purpose of handling the electrical output of the Walker Manufacturing Company, and was absent on a business trip at the time of his death.

THE GAGNIER-GRIFFIN SUSPENSION BRIDGE.

The cable way which is being exploited by the Gagnier-Griffin Suspended Railway Bridge Company, of the Masonic Temple, Chicago, provides an unique, practical and safe method of crossing chasms, streams or valleys by means of cars suspended on cables and running on trolleys. A separate cable gives the car action.

At present negotiations are in progress which look forward to a line across Niagara Falls and another for transporting passengers and horses across a river in Texas. The system is built with a factor of safety of 8, and has many advantages of cheapness, novelty and speed. For a summer resort attraction it is worthy of close investigation, and few other means of entertainment afford greater interest than a safe spin across a river or ravine, via the Gagnier-Griffin suspended car.

YOUNGSTOWN, O., HOUSE-MOVING ORDINANCE.

The Youngstown, O., city council has passed a complete and fair ordinance governing the moving of houses across electric street railway lines, telegraph and telephone lines, and fire and police patrol electric signal systems.

The ordinance provides that houses to be moved across street railway lines shall be so moved between the hours of 11 p. m. and 6 a. m.

Besides this, the ordinance requires that: "The mover of such house, building, or other structure, desiring to move the same across, through or under any of the lines or wires, shall give the local manager or agent thereof twenty-four hours previous written notice of his intention so to do, and shall specify the streets and routes along which he proposes and desires to move the same. It shall then be the duty of such manager or agent in charge of such lines or wires to raise or remove the same at a reasonable expense, not to exceed the actual cost of cutting and repairing said wires or leads, to be paid by the person or corporation giving such notice, so that such house, building or other structure can be moved through or past the same without injury to said lines of wires."

The violators of this ordinance shall upon conviction be fined in any sum not less than \$10 and not more than \$50.

THE Burlington & Winooski Street Railway Company of Vermont will attempt a large summer resort business, and to this end has increased capital stock.

## INDUCING TRAVEL AT OTTUMWA.

"Let those now ride who never rode before,  
And those who always ride, now ride the more."

The above are the introductory lines of an announcement made by the Ottumwa Electric Railway in regard to a reduction of fares. The plan is that of W. R. Daum, president, and has as its object a general stirring up of the community and an increase in the number of rides per capita. Small communities need something of the kind occasionally, and Mr. Daum's scheme seems to be a very good one. "Do you want to make 10 to 25 per cent a month on your money?" is the first question asked in the circular. As the majority of people are willing to do this, they read on into the announcement and learn that the company will make a special issue of non-transferable 100-ride ticket books as follows: One 100 ride book, \$4.50; three books, \$12.90; five books, \$20.25; ten books, \$38. Each book is good only for one person, but several members of a family or a number of persons can purchase books together at the reduced rates. After May 15 they will not be sold at less than \$4.50, but as an additional inducement to buy these books, the covers, if presented at the office, will be accepted as cash toward the purchasing of more books at the following values: If presented within 90 days from date of issue, 25 cents; if presented within 60 days, 50 cents; if presented within 30 days, 75 cents. By buying with nine others the individual can save 39 per cent the first month. If 1,000 tickets are sold by May 15 the company agrees to extend the time of selling at "club rates" one month.

The conditions, etc., printed on the cover, are as follows:

### OTTUMWA ELECTRIC RAILWAY.

REFUND 100 RIDE TICKET.

No. .... Issued to

NOT TRANSFERABLE.

This ticket is subject to the following rules and conditions:

1. It is good only for the use of the person named above.
2. Coupons are not good unless presented with the cover bearing the same number and must be detached by the Conductor. Only one coupon can be accepted as fare on any one trip, and then only for the person presenting the ticket.
3. In consideration of the reduced rate at which this ticket was purchased, I hereby accept the conditions and agree not to loan, give away or sell it, nor to tender coupons from it as fare for any one but myself.
4. This ticket is not good unless signed by the person to whom it is issued and also by the General Manager.
5. Any Conductor known to accept a coupon from this ticket as fare for any person that he KNOWS to be other than the one named on it will be discharged.
6. If this ticket is presented by any person known by the Conductor NOT to be the person named upon it, the Conductor will take it up, demand fare, and turn the ticket into the office of the company.
7. Conductors must read the name on each ticket when presented, and take care to prevent any but the proper person using it; also, use punch on coupons detached, ring for same and turn them in as cash fares.
8. If this cover is presented at the office of the company it will be accepted as cash towards the purchase of another coupon book at the following values: 25 CENTS if presented within 90 days, 50 CENTS if presented within 60 days or 75 CENTS if presented within 30 days from the date punched below, which is the date of issue. Only one cover can be applied toward the purchase of any one book.

Jan.	Feb.	Mar.	April	May	June
July	Aug.	Sept.	Oct.	Nov.	Dec.
1	2	3	4	5	6
7	8	9	10	11	12
13	14	15	16	17	18
19	20	21	22	23	24
25	26	27	28	29	30
31					

The coupons, of which there are four on a leaf, are numbered from one to 100, and also a running number including the entire issue. Coupons read as follows:

OTTUMWA ELECTRIC RAILWAY.

GOOD FOR ONE RIDE.

IF PRESENTED BY PERSON NAMED ON COVER.

NOT GOOD IF DETACHED.

## NEW PUBLICATIONS.

THE ELECTRICAL AND STREET RAILWAY REPORTER, is the title of a new candidate in the fields mentioned, and the first number, dated March, is well filled with interesting matter and illustrations. Publication office: New York.

CATALOG No. 53 of the Westinghouse Electric & Manufacturing Company, deals with the Direct Current Series Arc Light System, and is as handsomely printed and illustrated as is the Westinghouse custom. It sets forth the advantages of the direct current arc generator, and may be had on application.

RULES AND REGULATIONS FOR CONDUCTORS AND MOTORMEN, by J. E. Hutchinson, superintendent. This is a rule book for the employes of the Ottawa (Can) Street Railway Company. It is very complete in every detail, and particular attention is paid to the motormans' knowledge of the car and its parts.

CATALOG No. 56, of the Westinghouse Electric & Manufacturing Company, contains 45 elegantly printed pages, with many illustrations on the Wurts Non-Arcing Railway Lightning Arrester, with practical hints on protection against lightning. It contains much valuable matter and may be obtained on application.

NEW YORK SECURITIES, published and edited by J. P. Crittenden, C. B. Helffrich and R. V. Page, Jr., of New York and Philadelphia, will this year be published in two volumes. No. 1 will embrace all kinds of transportation both land and water, while miscellaneous, municipal and industrials will be cataloged in Part II. The name will be changed to "THE RED BOOK, UNITED STATES SECURITIES." It is a valuable and complete work, giving the best, latest and most reliable data in regard to all the numerous industries that put securities on the market. The New York office is at 45 Liberty street.

A REFERENCE BOOK OF TABLES AND FORMULAS FOR ELECTRIC STREET RAILWAY ENGINEERS, compiled by E. A. Merrill, author of "Electric Lighting Specifications." W. J. Johnston Company, Ltd., New York. 6 by 3 inches, pps. 95; flexible morocco; price \$1.00. This vade mecum is a logically arranged and concise collection of tables and formulae intended to aid the engineer in making estimates, ordering material, etc. All examples and explanations that are superfluous are excluded. Several original formulae are added to those compiled, and the whole is practically indexed. It is essentially a book for the practical man.

PERMISSION to use electricity as a motive power on the Erie Canal has been granted to the Cataract General Electric Company, of Niagara Falls. The company, it is provided, shall not charge for use of such power by the canal boatmen at a rate exceeding \$20 per electrical horse-power for each season of navigation, and it is promised that the rate will be much lower.

## Playing Cards.

You can obtain a pack of best quality playing cards by sending fifteen cents in postage to P. S. Eustis, Gen'l Pass. Agent, C. B. & Q. R. R., Chicago, Ill.

WE present on this page two views of the terminal power station of the Metropolitan line, San Francisco, built for the Midwinter Fair extension, and located near the grounds.

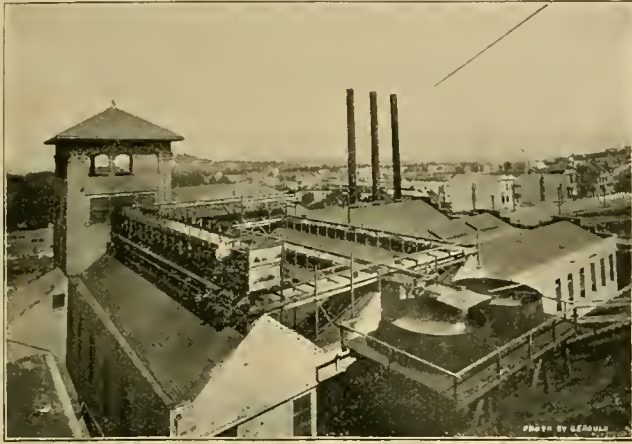

TERMINAL POWER HOUSE OF METROPOLITAN RAILWAY AT MIDWINTER FAIR.

JACKSON I. CASE, the young and progressive mayor of Racine, Wis., may resign his municipal office on account of his connection with the Belle City Electric Railway Company, which has a city lighting contract, as no one interested in a city privilege may hold city office.



TERMINAL STATION OF METROPOLITAN RAILWAY, MIDWINTER FAIR

THE Sandusky, Milan & Norwalk Electric Railway has closed a five-years' contract with the American Express Company for carrying packages along its line.

THE March meeting of the Massachusetts Street Railway Association brought out 21 members to hear a paper by G. E. Cutler, of New York City, on "Insurance Risks and Accident Insurance in General," and an interesting discussion of car wheels and brake shoes.



CALIFORNIA MIDWINTER FAIR.  
(Photographed expressly for the Street Railway Review.)

## THE CONNECTICUT ASSOCIATION.

The Connecticut street railway men met at the Tontine Hotel, New Haven, April 3, and perfected an organization to be known as the Street Railway Association, of the State of Connecticut. The following roads were represented:

Middletown Street Railway, by I. A. Kelsey; Danbury & Bethel Street Railway, by S. Harrison Wagner; Edgewood Street Railway, of New Haven, by Fred S. Wardwell; Waterbury Traction Company, by Geo. E. Terry and J. R. Smith; Central Railway & Electric Company, of New Britain, by A. M. Young and C. S. Landers; New Haven Street Railway, by David Corey, A. W. Dodge, Harrison Wagner and Director Laughton; Morris Cove Railway Company, of New Haven, by Mr. Townsend; Norwalk Tramway Company, by Geo. W. Peirce; Hartford Street Railway, by E. S. Goodrich; Stamford Street Railway, by Robert A. Fosdick; Fairhaven & Westville Railway, of New Haven, by Henry Parmalee; Derby Street Railway, by H. Halton Wood; Winchester Avenue Street Railway, of New Haven, by I. A. Kelsey. Col. N. H. Heft, of the Bridgeport Traction Company sent a letter endorsing the movement. The officers elected were H. Halton Wood, of Danbury, president; Henry Parmalee, of New Haven, vice-president; E. A. Goodrich, of Hartford, treasurer; Robert A. Fosdick, of Stamford, secretary. The executive committee is composed of the officers with Geo. A. W. Dodge, I. A. Kelsey and A. M. Young. The supplymen present were Geo. Pratt, of Jackson & Sharp; W. G. Bushnell, of the General Electric, J. C. Boyd, of the New Haven Car Register Company and H. J. Kenfield, of the New York office of the STREET RAILWAY REVIEW.

Robert A. Fosdick, the secretary elect, is thirty-three years of age and is a practicing attorney at law, of Stamford. He has been connected with the Stamford Street Railroad since 1887, serving as secretary four years and has been president and treasurer since 1892. His legal talents will no doubt be used for the benefit of the association.

## NEW PRESIDENT AT TOLEDO.

On April 2 the directors of the Toledo Consolidated Street Railway bestowed a deserved recognition on General Manager A. E. Lang, by electing him president of the company. Mr. Lang has long since established a reputation among the fraternity as one of the most progressive, careful and popular managers in the country, and the news of his preferment will be read with pleasure. W. S. Jewell, recently of Indianapolis, becomes manager. N. B. Ream, of Chicago, is vice president.



R. A. FOSDICK.

## NOT ALWAYS SO.

He was past middle age and drunk as he stumbled into a street car and slopped down beside a haughty looking woman who cast a scornful glance at him. He felt it through the booze and said apologetically in unsteady accents: "Madam, there are two circumstances about me which I know are deplorable: I am old and I am drunk, but"—and he bridled up in conscious dignity—"I was not always so." And even the haughty woman had to laugh.

## GENERAL ELECTRIC FEEDER PANEL.

The accompanying engraving is of the General Electric latest design feeder panel. The importance of sectioning trolley lines is being recognized more every day; not only because an accident on one section does not interfere with the others, but because of the mechanical and electrical strain on the entire station, on the occurrence of short circuits, when the line is not sectioned. The panel board here shown is form "C," and is arranged for two feeders on two circuit breakers with an ammeter and single pole switch for each. When fuses are used instead of the circuit breaker they are of copper and coiled in a spiral to produce a magnetic field which helps break the arc. The circuit breakers form "K" have the electric resetting device operated by shunt coils.

The panel is mechanically as well as electrically an able piece of work, and will be given deserved attention.

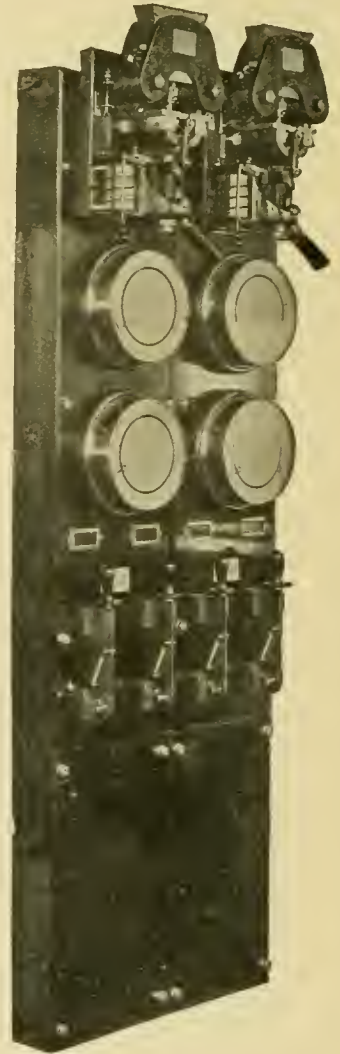

E. F. DEWITT, of Lansingburg, N. Y., was a welcome visitor at the REVIEW office this month. He was on a successful western business trip.

THE Isle of Man Tramways Company has been submitted an offer for the purchase of the undertaking by the Douglass & Laxey Electric Tramway Company. Price made, \$190,000, which will be accepted.



WINDSOR & KENFIELD,

PUBLISHERS AND PROPRIETORS,

269 DEARBORN ST., - - - CHICAGO.

Published on the 15th of each month.

SUBSCRIPTION, - - - TWO DOLLARS.

FOREIGN SUBSCRIPTION, - - - 20 SHILLINGS.

Address all Communications and Remittances to THE STREET RAILWAY REVIEW,  
269 Dearborn Street, Chicago.

H. H. WINDSOR,  
Editor.

F. S. KENFIELD,  
Business Manager.

### CORRESPONDENCE.

We cordially invite correspondence on all subjects of interest to those engaged in any branch of Street Railway work, and will gratefully appreciate any marked copies of papers or news items our street railway friends may send us, pertaining either to companies or officers. Address:

THE STREET RAILWAY REVIEW,

269 Dearborn Street, Chicago.

Eastern Office, Room 14, No. 126 Liberty Street, New York.

This paper member Chicago Publishers' Association.

Entered at the Post Office at Chicago as Second Class Matter.

VOL. 4.

MAY 15, 1894.

NO. 5.

FIRST, it was ye deadly trolley; now, it is electrolysis. We wonder what witchcraft will be invoked next. While the faggot fires of Salem have long since been extinguished and the ashes blown to the four winds, they seem to have sown seeds which in these latter days are springing up, and while the fruit is of another color, one can trace the same unreasonable prejudice and willful ignorance that characterized our pious but misguided forefathers.

THE first rail welding on a really large scale is now proceeding at St. Louis, and the description in this issue will be read with intense interest by all. The work is proceeding satisfactorily and rapidly and has every possible promise of entire success. A year hence, when the track has passed its first summer and winter, there may new developments have arisen which cannot now be anticipated, but we believe the joint problem has been solved and most earnestly wish our progressive friends in St. Louis the glory which belongs to pioneers and the success their enterprise so largely deserves.

THERE is now a strong probability that the movable sidewalk system will be adopted on the Brooklyn bridge. We believe the REVIEW was the first to point out the special fitness of this system as the best, cheapest and most effective solution of what has been a very vexed question. It is now being carefully considered and plans

drawn in detail, which conclusively demonstrate its adaptability to the place and work. To urge its adoption would be but to repeat what has been expressed time and again in these columns. The movable sidewalk is exactly what is needed on the bridge, and we know of nothing that so fully meets its requirements.

DELAYS on cable lines always seem of much longer duration than they actually are, and the public has been taught to believe that such stoppages are most frequent and covering a long period. The record of the West Chicago Street Railroad for the month of March is sufficient to afford a strong argument in opposition to this belief, for the delays on the Milwaukee avenue line during the entire month aggregated but nine minutes, and those on the Madison street line but five minutes; on Washington street loop, nine minutes, and on Blue Island avenue system twelve minutes. This is an exceptionally good record for any system, on any street, and is well worthy of equal prominence with the common statement made to the contrary.

SUMMER riding promises to begin early this year, in fact open cars have already been in service fully three weeks in most cities in this latitude. With less riding than in other years of workingmen going and coming from factories and other industrial plants, it is imperative that the manager encourage and foster pleasure riding to its largest extent. The various methods in which this can be accomplished have already been elaborated in our columns during the past few months, and it now remains for the fertile-minded manager to select such means as best commend themselves to the wants of his own locality. We shall be glad to be advised of all new departures in this line and to publish a full description for the benefit of others of the fraternity who are anxious to develop their own business.

THE outlook of trade for the present month is more encouraging than for some time past. The manufacturers and agents of the smaller supplies, particularly those whose wares are staples, find trade greatly improved, as the stripping of reserve equipment has come to an end and buying is a necessity. At the same time collections are improving, and there is less careless credit as well as less careless expenditure. Heavy supplies, engines, power equipment and cars have been helped considerably by large orders both East and West, particularly in New England. The same remarks as to credits applies equally in this case. Summer resort traffic promises only fairly, but many roads will open up local pleasure grounds to induce traffic. Fewer new firms have entered the supply field, but those few are better prepared for the struggle for existence.

THE consolidation of three important street railway systems in Kansas City is a wise move. A few years ago when that city was experiencing an unparalleled boom, a new road was promoted almost every month, and bank-

ing on the future, scattering lines were built in ever direction. Indeed for a time, one had scarcely more to do than print bonds, fill a satchel, make a trip to the east, sell out and return home between two Sundays. The result was a multiplication of certain lines beyond all possible reason, and the subsequent division of values into very minute parts was inevitable. The consolidation of three lines will now reduce general operating expenses very materially, and the selection of the best men from each road should afford a strong and experienced management. The deal ought to prove of equal advantage to stockholders and the public. Thus far the street railways of Kansas City have done much more for the town than the town has for the roads.

AN interesting case, which may prove an important precedent, has been decided here in the United States Court of Appeals. A male passenger, who could have boarded the rear car of a cable train then at a standstill, ran forward to take the grip car. While doing so, the signal was given to start, and while he was attempting to board the grip car it moved. He was thrown down and claims injury. The court held that the passenger has a right to select one car in preference to another, and that in doing so, he is not guilty of contributory negligence. In reviewing the case, Judge Bunn said:

"The conductor of street cars, having the safety and even the lives of patrons in his keeping, has not discharged his whole duty to the public when he has stopped his train and waited what may appear, according to his schedule, a reasonable time for passengers to embark. He is bound to exercise the highest degree of diligence practicable to protect passengers and prevent accident. He is bound to know when he starts his car suddenly out with full force that no person attempting to embark is at that moment with one foot on the platform and the other on the ground and with his hand upon the railing in the act of getting on board, or is otherwise in a position of danger."

Two managers were recently discussing operative means and methods, when one remarked he was going to make a big saving by taking off half his cars. To this the other replied: "That is the worst possible economy you can make." He then went on to state that he, too, had been inclined to the same severe resort, but after careful study of the question had become convinced that it was wrong. He had spent a great deal of money in educating his patrons up to a point where they had begun to appreciate the value and convenience of a good car service, and were getting out of the old chronic walking habit. Now to cut the service down to a radical extent would make the headway so great a very large portion would find it quite as expeditious to walk as to wait on a car, and less expensive. In this way a great part of the education necessary to bring a community up to a good riding point would be lost and they would quickly backslide. While in most cases roads have absolutely been obliged to curtail the normal service, still there is much force in the above. Economies should and must be rigidly practiced, but the saving should

come almost everywhere else before crippling the service. People in these days need little encouragement to walk, and companies can poorly afford to throw the last straw in a patron's decision not to ride, by no car in sight, and an uncertainty as to when one may be expected.

THE sentence in Toledo, by Judge Pugsley, of three men who participated in a recent street railway strike to the extent of damaging the company's property, should serve as a warning to others, who, in the desire to carry their point, overstep the bounds of law. There has been altogether too much sentiment and laxity in judicial and official quarters in dealing with those men who seem to consider that wrong doing becomes a rightful prerogative if only it be done under the license of a strike. The fact that one man, or any body of men, are dissatisfied with their employment, gives them no rights which do not exist at all times, and the mere fact that they are embolden by numbers to destroy property which does not belong to them is no excuse for the violation of the law which, under normal conditions, they would not dare to transgress; and transgressing, would expect punishment. Might falls far short of making right, and in these days when few roads are making any money and the great majority are barely paying expenses or operating at a positive loss, the employe must divest himself of the belief that by resort to force he can in that way improve in the slightest degree the ability of his employer to pay more wages. In some places the men have nobly showed themselves worthy of the name and voluntarily and unanimously agreed to work for less pay, or where it had been promised to relieve the company of its obligation to increase wages which it had expected and hoped to be able to grant. There is not a street railway employe in the country whose place to-day could not be filled for less money than he is receiving, and under these circumstances it behooves the men to exercise reason, common sense and patience, instead of trying to make water run up hill.

"Our stocks are selling for somewhat less than they did a year ago," said a prominent western manager to us the other day, "but I firmly believe they command more confidence than then, and are looked upon as a better and safer investment." In reply to our inquiry as to how this condition had been brought about, it was stated that notwithstanding an enormous shrinkage in earnings, and especially in profits, that the management had succeeded by suitable retrenchment and economy in meeting its interest payments with accustomed promptness and had kept its pay day and bill settlement day without a single postponement. There is no small food for thought in this fact, and it is encouraging to extract even this crumb of comfort out of the discouraging returns which have followed a year of exceptional trial of spirit and body to the average manager. The soldier must have a battle in which to exhibit bravery, and the surgeon a critical case to prove his skill. The manager has had both, and as mentioned, these roads which have been able to keep the

ship to the wind and plow through the stormy seas without losing a spar, now stand proudly out to sea with a confidence of the investing public which did not exist before. The manager has been able to prove the strength of his craft and his own ability as a captain, and the local capitalists who perhaps never before had inclined to the purchase of its securities, now have a confidence in the worth and stability of their road which never existed before. In the case of those roads which have been less fortunate, it does not by any means follow that their misfortune is in any degree due to poor management, for in not a few cases to our positive knowledge the efforts of the manager have been thoroughly well directed and untiring, and the fact that no greater loss has been made under the unfavorable circumstances is really quite as much to their credit as the successes of others. There are still other roads where bad management can be blamed for disaster, arising out of a mistaken economy in placing the property in the hands of cheap or inexperienced men. Such deserve less sympathy, and should lose no time in correcting this evil. The trouble, however, all too often lies in the inability of directors to intelligently judge of what is good or bad management in the officers they select, and it not infrequently happens that the superintendent or manager is the only really practical man in the lot, and his hands are so tied that he is expected to make bricks without straw, or compelled to work along lines which he knows lead to almost certain defeat.

ONE of the most difficult things to understand in connection with street railway and allied trades is the unwillingness of some manufacturing companies to publish technical details in regard to apparatus. It is easy to see why a company should be very careful of plans and drawings of apparatus that is not yet and possibly never will be on the market. But it is carrying the matter too far when a company is not willing to give out the fullest information possible about apparatus that is on the market. Anything but the utmost readiness in giving out such information is liable to create a feeling of distrust on the part of buyers. The time is past when it is sufficient, simply, for a company to call a piece of machinery "absolutely perfect," the "best on the market," etc., in order to sell it. Street railway managers are not fools. There may be a few of that kind, but the number is daily decreasing. They want, not claims in regard to apparatus, but full particulars and facts. Being of sound mind and with some technical knowledge, they are able to judge for themselves as to the merits of devices. The peculiar information withholding policy of some companies, was recently brought to our mind by an electrician of a large system, who had to use no small "engineering" skill to get certain blue prints, giving technical details in regard to a piece of apparatus being installed on his road. The apparatus had been on the market for some time and was in extensive use. By going to some trouble the information could have been obtained from a study of the apparatus itself, and the unwillingness of the

manufacturing company to furnish blue prints was simply childish. Had anyone wished to copy the device, withholding the drawings would be but a slight deterrent. Such policy invariably does more harm than good. In this particular case it was not strange that the gentleman was somewhat put out at the inconvenience caused him. There is another class of companies which, although willing to give all the information in their power, exhibit a great lack of judgment as to what should be inserted in the printed information of all kinds which is sent out by them. It is no uncommon thing to see matter purporting to describe certain devices, but which in reality is nothing but a lot of claims. As said before, the intelligent buyer in our field wants not claims but facts. He is able and will draw his own conclusions. Descriptions which do not describe simply provoke him. The mistake is a natural one on the part of the dealer, as he is anxious to show the merits of his goods, and with this end in view he forgets all else, to his own disadvantage.

THE important part which the construction and operation of interurban railways is to play in the near future, leads us this month to give more than usual space to a subject which has always been most earnestly advocated in these columns. The magnitude which this branch of electric railway construction is rapidly attaining is but faintly realized, even by those who pride themselves on advanced ideas. The introduction of these lines means even more for rural districts than the conversion of a horse line to electricity in a city possibly can, for it affords transportation where none existed before. As an educational and social reform measure, the value of the interurban raises the curtain on a future full of hope and promise, and will advance the standard of intelligence in farming communities far above what it could attain in any other way. Lectures, theatres, entertainments, and Sunday services are all brought within reach of thousands, now as effectually isolated from these privileges as though a hundred miles away. For instance, a ten mile run on an interurban can easily be made in less than half an hour, and a walk of from a quarter to one mile from the home to the line is an easy matter. This brings upwards of one thousand residents of rural districts for each ten miles of road, within easy riding distance of the town or city. The ability to secure daily papers and mail will afford the farmer the latest market reports, and furnish protection against unscrupulous buyers, especially on rising markets. The ability to daily market perishable products of fruit and vegetables opens up a wholly new avenue of profit to the farmer; and while constituting an important feature of the freight receipts, is equally helpful to the city buyers, whose variety and quantity are thus indefinitely increased. As a feeder, also, to steam roads, the electric interurban cannot be over-estimated. In short, the good offices of country lines may be counted by the score, while there is not a single valid objection which can be raised in opposition. We repeat, the future of this branch of railway work, when once understood, will eventually equal in magnitude and investment the combined invest-

ments in electric railway systems in all the cities. Country papers have a magnificent opportunity to advance immeasurably the values of farm property and the comfort and well being of farmers, by the persistent advocacy of such lines at all places where conditions are such as to insure success; but farmers must learn at the start that they cannot afford, by exorbitant demands for right of way, to stifle the enterprise which is to bring them, above all others, increased returns. No farm is so good but its owner can well afford to donate the little strip necessary to lay the track, and stocks and bonds on which the line is built should be issued in small denominations of, say, \$25 or \$50, or even \$10, to enable the raising of a whole or part of the necessary funds from those living along the road.

AFTER a hard fought battle the North Chicago Street Railroad Company has gained its electrical franchises along Lincoln and Milwaukee avenues, and will now proceed to make the bald and unattractive prairie a habitation of man, if not to blossom as the rose. The street railway company deserves the greatest credit for its enterprise and persistency in pushing the matter to completion in the face of all obstacles. The unreasonable demands of a few mossbacks along the route were reflected in the veto of the mayor, who demanded certain lighting concessions in return for "the use of the streets." At present the entire course of the line resembles a country village more than the part of a great city. Property owners should be glad to have the price of real estate raised, and residents should appreciate the ability to get somewhere this side of eternity without restrictive clauses.

#### THE LOCATION OF CAR TRACKS.

In a recent article on the question of the location of street car single tracks on country roads, Henry Manley makes objection to the two present methods and advocates a third.

Mr. Manley objects to the centering of the tracks as "taking up the whole road for the use of the street railway," and to the placing of the track on one side as "bringing the cars into the front yard and interfering with the standing places of teams, as well as preventing proper surface drainage." The theory advocated is placing the single track parallel to the center of the road and about five feet to one side. This, he claims, will obviate all the difficulties experienced with other methods. The only criticism he apprehends is that his method brings the track too near the course of ordinary travel. From the standpoint of experience, it seems to the REVIEW that the ordinary centering cannot be improved upon, as it gives down-going and up-going street traffic all the room necessary on a sufficiently broad road and takes up only the part of the thoroughfare that is of least use to the teamster, namely, the necessary division between passing vehicles. Circumstances ordinarily dictate the position of a track, and Mr. Manley may be

assured that electric railways wish the most convenient position where its tracks will be least liable to be crossed by teams.

#### AN AID IN EDUCATING MOTORMEN.

The proper handling of the controller is the most important point in a motorman's education, and it is almost impossible to train a man to handle the controller properly unless he understands the principles of what is going on and the connections that are being made as the handle is thrown from point to point. Educating a large number of motormen who have had no previous knowledge of electricity is a difficult task at its best, and anything to simplify matters ought to be gladly adopted. The accompanying illustration is from a blue print which

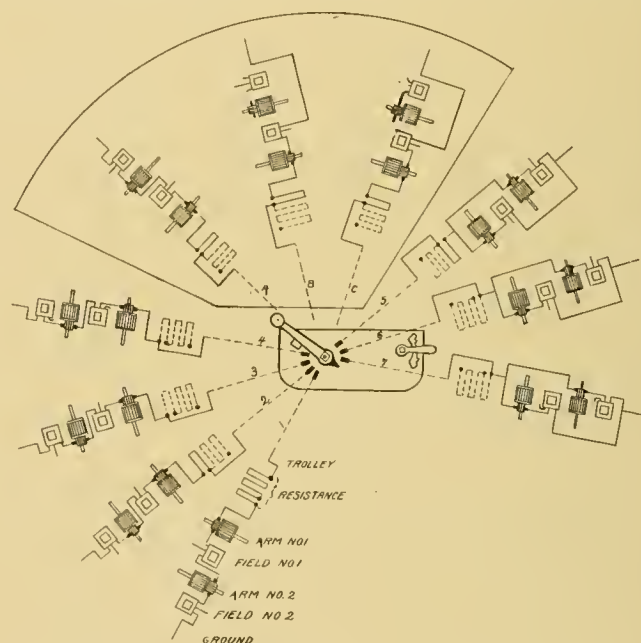

is supplied to every motorman on the Calumet system of this city. On the same sheet with it are a few instructions and a brief explanation of the connections. The idea of the diagram, as will be seen, is to give the connections for each controller point in the same relative positions as those taken by the controller handle in making the corresponding connections. This particular diagram is for the General Electric type "K" controller wired to W. P. motors and using the field loop method of control. Of course the idea is applicable to any controller. With plain rheostat control such diagrams would not be worth the while, but where the connections are as numerous and varied as on series-parallel controllers, anything that will simplify matters to the befuddled mind of the motorman during the learning period, should be adopted. This department on the Calumet system is under the charge of H. P. Rustling, who is doing much to save repairs by a thorough education of the men under him.

THE Grand Avenue Cable Company, Kansas City, Mo., has instituted a system of electric push buttons to signal the conductor. One car is equipped experimentally.



## ELECTRIC TRACK WELDING AT ST. LOUIS.

Three and One-Half Miles of Continuous Rail.—The Baden & St. Louis Railroad the Second to try the Continuous Rail Experiment.—The First New Track so Laid.

BY RICHARD MCCULLOCH, ELECTRICAL ENGINEER, CASS AVENUE & FAIR GROUNDS ELECTRIC RAILWAY, ST. LOUIS.

To build a track which would obviate the ceaseless trouble with joints and to perpetually insure a smooth and easy riding roadbed, was the object of the management of the Baden & St. Louis Railroad when, last

track with hot riveted rail joints. All of these trials gave satisfactory results. Last year, the Johnson Company, having procured a suitable electric welder from the Thomson Electric Welding Company, several miles of track were welded on the West End road, of Boston. There was some trouble from rails breaking near the welds, but the Johnson Company persevered with its experiments and entered the field this year prepared to guarantee its work. Street railways have shown a great willingness to try welded track and this season will be one of great activity along this line. The road under consideration is the first to begin welding operations this season.



THE WELDING CAR.

February, it closed a contract with the Johnson Company to weld together the rail ends of its reconstructed road. In the past few years there have been several experiments with continuous track, and all tend to show that the difficulties which would be supposed to arise from contraction and expansion can be neglected. The most scientific and thorough experiment along this line was made by A. J. Moxham, president of the Johnson Company, early in 1892, and reported to the American Street Railway Association, at Cleveland, in that year. In this case the rails were so bolted together as to be practically continuous. Previous to this Philip Noonan laid some track with hot riveted rail joints, on the Lynchburg & Durham Railroad, near Gladys, Va. Some time ago C. W. Wason, of the Cleveland Electric Railway, laid some

The Baden & St. Louis Railroad is one of the oldest street railways in St. Louis, its charter having been granted in 1870. It runs between the north end of the Broadway Cable and Baden, a suburb in the northern part of the city, passing on its route O'Fallen Park and the two principal cemeteries of the city. The road was formerly operated as an independent horse road, having a single track with turn-outs, but as it has recently passed under the same management as the Broadway Cable, it was decided to operate the road by electric power and use it as an extension of the cable road. The road is about three and a half miles long, and is to be double track the entire distance. There are no crossings with other roads, and although there are no sharp curves, it has a number of long bends of eight hundred to two thousand

feet radius. In making the sharper bends, the rails are curved in a rail bender and then welded in place. The street in which the track is laid is an old macadam road, varying in width from sixty to eighty feet, and is used very much by farmers in bringing their produce to the city.

The current for the operation of the road and for the welding process is obtained from the new Cass Avenue &

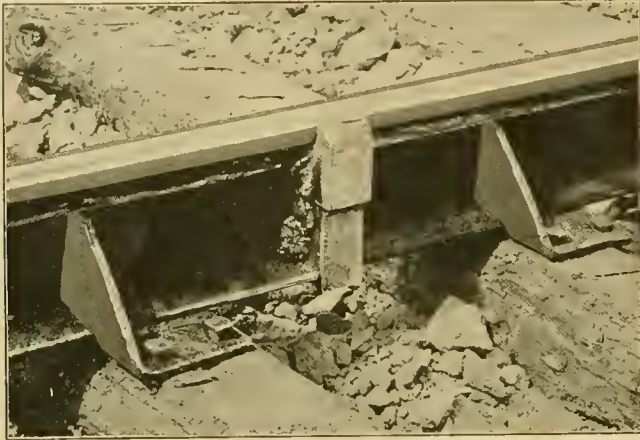

WELDED JOINT, SHOWING LUGS.

Fair Grounds Railway power house, this road being under the same management as the Broadway Cable. The poles for the span and feed wires were all erected before the laying of the track began. The terminus of the Baden road is about two and one half miles from the power house. Five Number 0000 wires are run from the station, four of them being overhead and one a track feeder. As there is no direct rail return to the power house, an additional track connection is secured in the following manner: The terminal sheave of the cable is well bonded to the first rail of the new electric road, and at a point where the cable track crosses an electric track, the carrying pulleys of the cable are bonded to the rails of an electric road which runs directly to the power house. In this manner, the cable and conduit act as return conductors.

Preparatory to the welding operation, it was found necessary to lay the track, tamp it, line it, and surface it completely before the joints were welded. At the start an attempt was made to weld the joints first and tamp and surface the track afterwards, but the weight of the welding car was such that the rail was bent down in the middle and raised at the ends, making joints welded in this manner high.

The road-bed is first plowed out to the necessary depth. Then six inches of macadam are thrown in and rolled. Upon the rolled surface are placed the hewn white oak ties, three feet apart. The rails are then spiked to the ties and the track tamped to grade and filled in to the tops of the ties. The rails are then ready for the welding of the joints.

The welding car is equipped with two W. P. 50 motors, with the rheostat, reversing switch, etc., of an

ordinary street car. In addition to this it has the welding circuit shown in Fig. 1. The current from the trolley passes through an automatic circuit breaker, switch, ammeter and starting rheostat to a transformer which transforms from the 500 volt continuous to an alternating current. This transformer resembles an ordinary four pole General Electric 100 kilowatt dynamo. To obtain the alternating current four leads from the windings are taken off at equal distances around the armature and led to two collector rings on the armature shaft. The speed of the transformer is about 1,100 revolutions per minute, so that the periodicity of the alternating current is about 4,400 per minute. The alternating current from the collector rings passes through a regulating induction coil with a moveable iron core to the welding machine, an illustration of which is here given. This machine is hung on a crane so that it may be set over either rail, and is simply an alternating current transformer on a huge scale in which the rail joint completes the secondary circuit. It was made by the Thomson Electric Welding Company, and operates on the same principle as its well-known machines. The insulation of the coils is paraffine oil and the secondary consists of a single turn of an enormous bundle of sheet copper strips. These strips lead to two copper contact plates, between which the welding is done. The distance between the plates is controlled by a toggle joint operated by a screw, so arranged that by a slight turn of the screw a great pressure may be brought to bear upon the weld.

In addition to this circuit, the welding car contains a motor for operating the crane, and another for driving a pump which circulates water in the welding machine.



THE COMPLETED TRACK.

The car is very heavy, weighing about 30 tons when equipped for work. There is also a small car which carries two motors, operating emery wheels attached to flexible shafts for polishing the joints preparatory to welding.

The welded connection between the rails is made by means of lugs welded to the web of the rail. A section

at the joint is shown in Fig. 2. It is intended that enough plastic steel shall enter the joint to make a butt weld, and that additional security be afforded by the lugs welded to the web. The bottom lugs, numbers 1 and 2, are first welded. After they are in position, the operation is completed by welding numbers 3 and 4. It requires

to be welded, and the welding takes place at the rear of the car, so that it is never necessary to run over a hot joint. The webs of the rails are polished with emery wheels for about two inches on each side of the joint. The joint is then clamped by means of a gun metal casting, which holds the rails in proper position while the

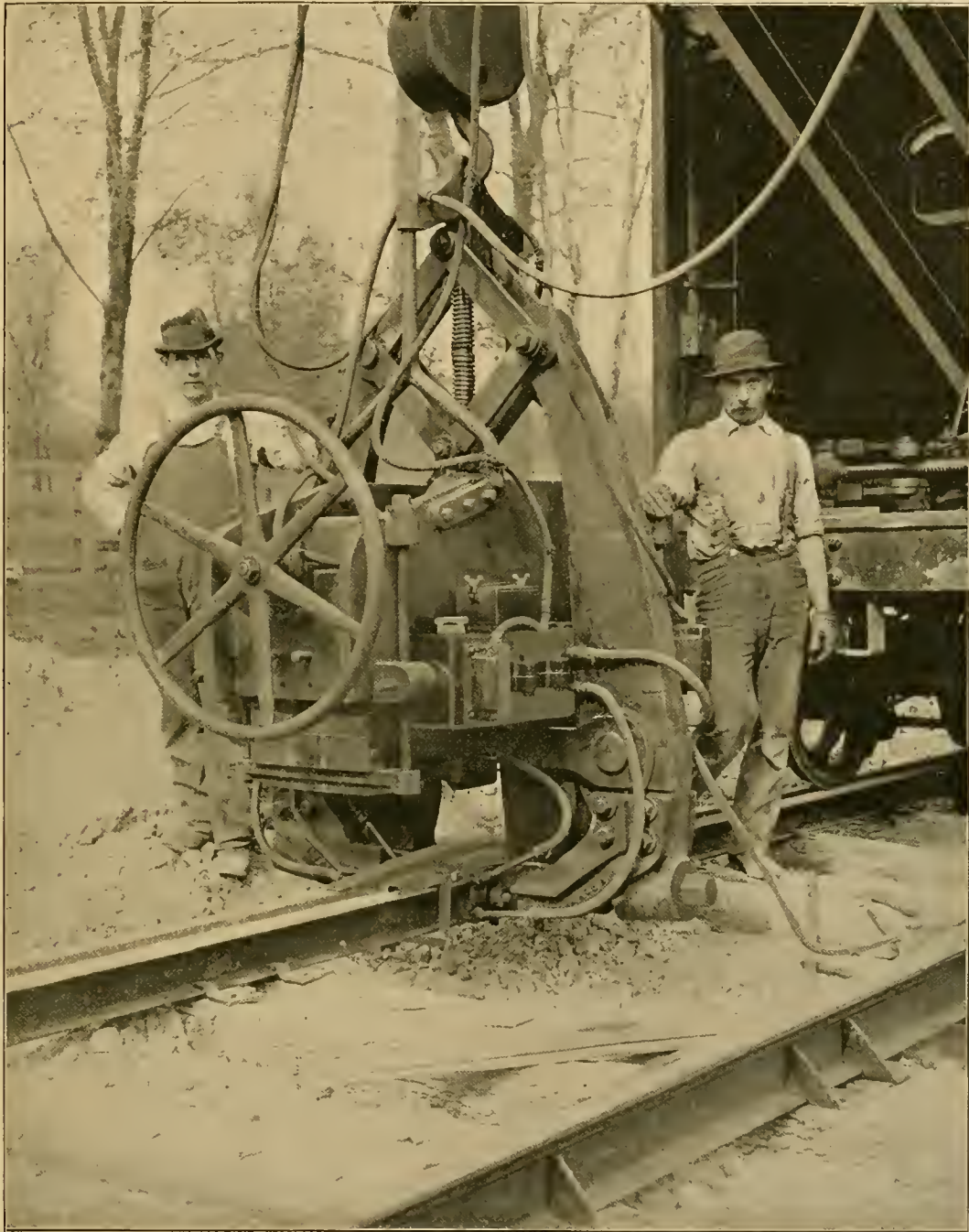

WELDING MACHINE AT WORK.

from one to two minutes to make each weld. The potential at the welder is transformed down to four volts. The direct current transformer takes from the line about 250 amperes at 500 volts.

The operation of welding is as follows: The ends of the rails are butted together by driving a wedge in the joint ahead. The welding car is then run over the joint

weld is being made. The bottom lugs (Numbers 1 and 2 in Figure 2) are then placed in position and the contact clamps screwed down upon them. When the circuit of the secondary coil is thus completed, the switch on the welder is closed and the iron core of the induction coil slowly raised. Almost instantly a dark, ruddy color appears in the lugs which gradually brightens until the

welding heat is reached. A quick turn of the screw which operates the toggle joints brings the lugs firmly up against the rail and forces the plastic steel into the joint between the ends of the rails. The upper lugs (Numbers 3 and 4) are quickly inserted, the contacts

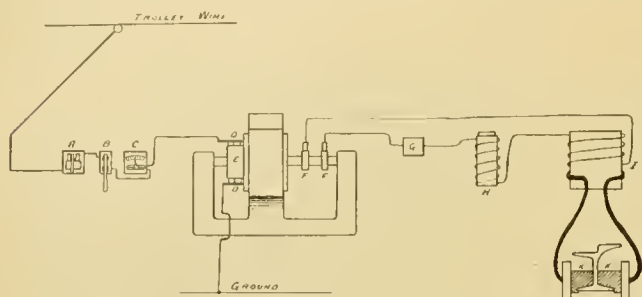

FIGURE 1.  
DIAGRAM OF WELDING CIRCUIT.

- |                               |                             |
|-------------------------------|-----------------------------|
| A - AUTOMATIC CIRCUIT BREAKER | G - BRASS SWITCH            |
| B - SWITCH                    | H - INDUCTION COIL          |
| C - AMMETER                   | I - WELDING MACHINE         |
| D - BRUSHES.                  | J - LUGS FOR WELDING RAILS. |
| E - COMMUTATOR                |                             |
| F - COLLECTOR RINGS           |                             |

raised and screwed down upon them and they are welded in the same manner as the lower lugs. Pieces of carbon are previously placed upon the top of the rail so that this portion is carbonized and hardened by the process. After the lugs are welded the tread and flange are smoothed up by hammering. The welding has been so perfect in many instances, that after the track has been filled in, it is impossible to see the joint in the tread.

The greater portion of the time is consumed in preparing the joints, moving the machine, setting up the welder, etc. The machine has been completing 30 to 50 joints per day of ten hours.

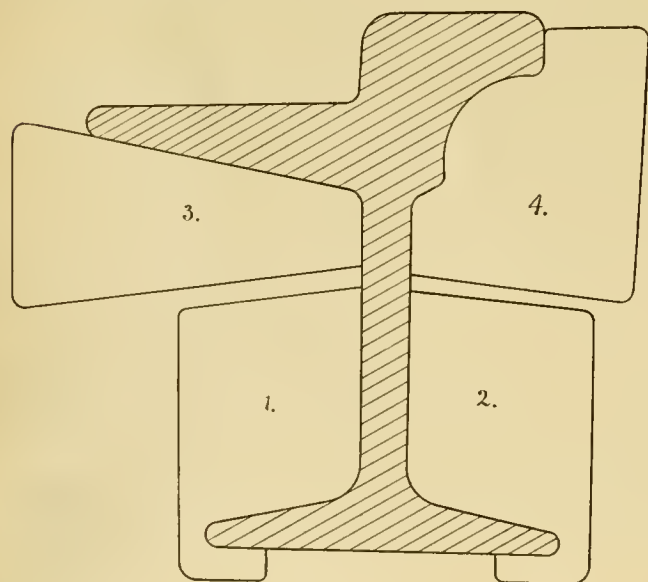

FIGURE 2.  
LUGS WELDED TO THE RAILS.

At the present writing no great trouble has been experienced from expansion and contraction. The temperature of the air has varied exceedingly. Several of the joints broke soon after welding, but these were probably imperfect welds. These joints were re-welded

as soon as the break was discovered. No buckling has thus far been noticeable on the warmest days. The track is filled in as soon as possible after welding, but on several occasions, 300 to 500 feet of welded track have been left open for several days without bad results.

The results have been very satisfactory and the management of the company is very sanguine as to the outcome of the experiment. G. Milton Brown, of the Johnson Company, is in charge of the operations.

## THE M'CORMICK RAIL.

The McCormick combination rail and joint, on which letters patent have recently been issued, consists of a T rail made in two parts. The form of these parts and the manner of fitting them together may be either as Fig. 1 or Fig. 2. Fig. 3 shows the method of joining the ends

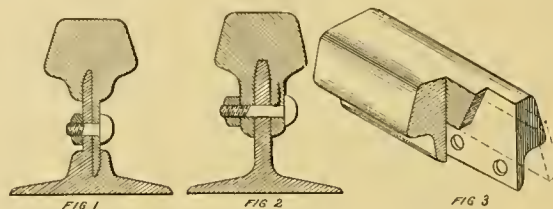

of the top part of the rail. The principle is somewhat similar to rails which were tried on steam roads in times past, but which were abandoned on account of costing too much in proportion to the advantages gained. The expense of tool work on the rail ends would in this case be very great.

## POWER HOUSE FIRE AT SACRAMENTO.

An early morning fire, April 19, destroyed the electric plant of the Capital City Gas Company, which supplies power to the thirty odd miles of the Central Electric Railway, in Sacramento, Cal. Twenty-four dynamos were destroyed. The total loss was \$300,000, including two large engines, the dynamos and the building. The fire is thought to have originated in the switch board.

## THE DEADLY LOCOMOTIVE.

Opposition to progress, we are relieved to discover, is not peculiar to American citizens. The Official Gazette, of Peking, China, which publishes the ukases of the emperor and the declarations of the highest courts, has severely rebuked the Buddhist priests who denounced the locomotives as causing the illness of her imperial highness, the emperor's mother. The Gazette states that the high court decreed that the smoke and noise of the locomotives in no wise injured the august lady.

THE New Jersey Consolidated Traction has a plan for freight service between Newark and New York. The freight will all be carried between one and five in the morning.

TRAINS FOR INTERURBAN SERVICE.

The greatest activity along electric railway lines within the next few years will be in the direction of interurban roads. This service necessitates a few changes from city railway service, as has been demonstrated in a few roads already built, and as the business grows interurban roads

will probably evolve a distinctive class of rolling stock. An interurban road projected in a neighboring state, and one which has good promise of being built, is considering plans for a radically different service from that now used. The plans were made by Charles C. Caldwell, electrical and mechanical engineer, now of Shelbyville, Ind. Mr. Caldwell was born in Washington county, Pa., in 1865. He became interested

in electricity about five years ago, and was engaged in the construction of electric light plants at different points in the south and southwest. Electric traction has been to him for a year a subject of deep and broad study and of practical investigation, and he is now beginning to advocate what he feels sure is to be realized in the near future, namely, inter-

urban electric service, using the methods of station and track construction and following somewhat closely the ideas of steam roads.

In his opinion, the trains for this particular service, and the motive power and speed demand changes from those now in daily use. Specifications for such trains have been drawn up by Mr. Caldwell, and several car builders have prepared plans. The car builders' plans submitted can be seen in the engravings. The Barney & Smith train as here shown, is one of

the most elegant trains ever designed for electric service. It can be operated over a track having very sharp curves. It is intended for use with the electric locomotive described later. The cars are 36 feet over all. The width over sills is 9 feet, and the height from center of deck to floor, 8½ feet. The weight of each car here described is 25,000 pounds. The Janney narrow gauge passenger train coupler is used. The wheels are 33 inch. The Brewer & Krehbeil train incorporates the same principles

as the train exhibited at the World's Fair and now in regular service on the Chicago & Alton. The dimensions are the same as of the Barney & Smith cars. The

train is of four cars, having no baggage car as the other trains have. The first car shown is intended to be made the motor car, as on the Intramural road, and is exclusively a smoker. The trucks are equipped with open spoke 36-inch wheels on 4½-inch steel axles. The wheel base is 5 feet. The Pullman plans are for double-decked cars, such as have been previously exploited.

The electric locomotives to be used are similar to the one exhibited by the General Electric Company at the World's Fair, weighing 30 tons and having a maximum speed of fifty miles an hour. It will be



PULLMAN STAIRS, INTERIOR VIEW.

provided with two trolleys and an electric headlight supplied from a rotary transformer.

The feeders proposed are old rails having the ends joined with the ordinary splice bar, and bonded with copper equal to the carrying capacity of the rail. Two lines of these rails will be laid along between the tracks a little to one side of the center poles. These rails are to be put on porcelain insulators and inclosed in a top with a  $\Delta$  shaped cover, so as to shed water and keep people from walking and standing on it. The feeder box is then filled with pitch and raised to the level of the rails on posts placed 4 or 5 feet apart. From this box, taps will be led up the poles to the trolley. This arrangement will, it is claimed, cost only one-tenth the amount required to install copper feeders of an equal capacity.



PULLMAN CENTER ENTRANCE.



INTERIOR PULLMAN TRAIN.

C. & G. COOPER & Co., of Mt. Vernon, O., have received recent orders for two 750-horse-power engines, for the Allentown & Lehigh Valley Traction Company, Allentown, Pa., and the contract for the engines for the Nassau Street Railway Company, of Brooklyn, N. Y. The first power station of the latter will require 6,000-horse-power, and the first installation will be of three 750-horse-power cross compounds, direct connected. The second station will be like unto the first.

W. H. LeRoy, manager of the Texas summer amusement circuit, to which the greater number of Texas street railways belong, has arranged with Superintendent Urie, of the Austin Rapid Transit Company to place his line on the list. The company owns an opera pavilion.

THE Electric Railway Equipment Company, of Cincinnati, O., is very busy with recent orders. One of these is 4,000 tubular poles for the City Railway, Dayton, O., the Cincinnati Street Railway Company, and two New Haven, Conn., lines. A new hanger, to be called the Star, will soon be marketed. It is an interchangeable device and will bear investigation.



BREWER & KREHBEIL VESTIBULE.

Two cranks, supposed to be members of a suicide club, recently stripped to the waist and threw themselves under the wheels of a Hazleton (Pa.) electric car. The motorman saved their lives by a quick stop, and received only curses for his pains.

THE Austin Dam Railroad Company, Austin, Texas, has made a proposition to the city, which owns the track, to pay the rent due to date and to enter then into a new lease of the track, providing the city cuts the rent 50 per cent. The present rate is five thousand dollars a year and is not justified by the present earnings.



BREWER & KREHBEIL THREE CAR TRAIN.

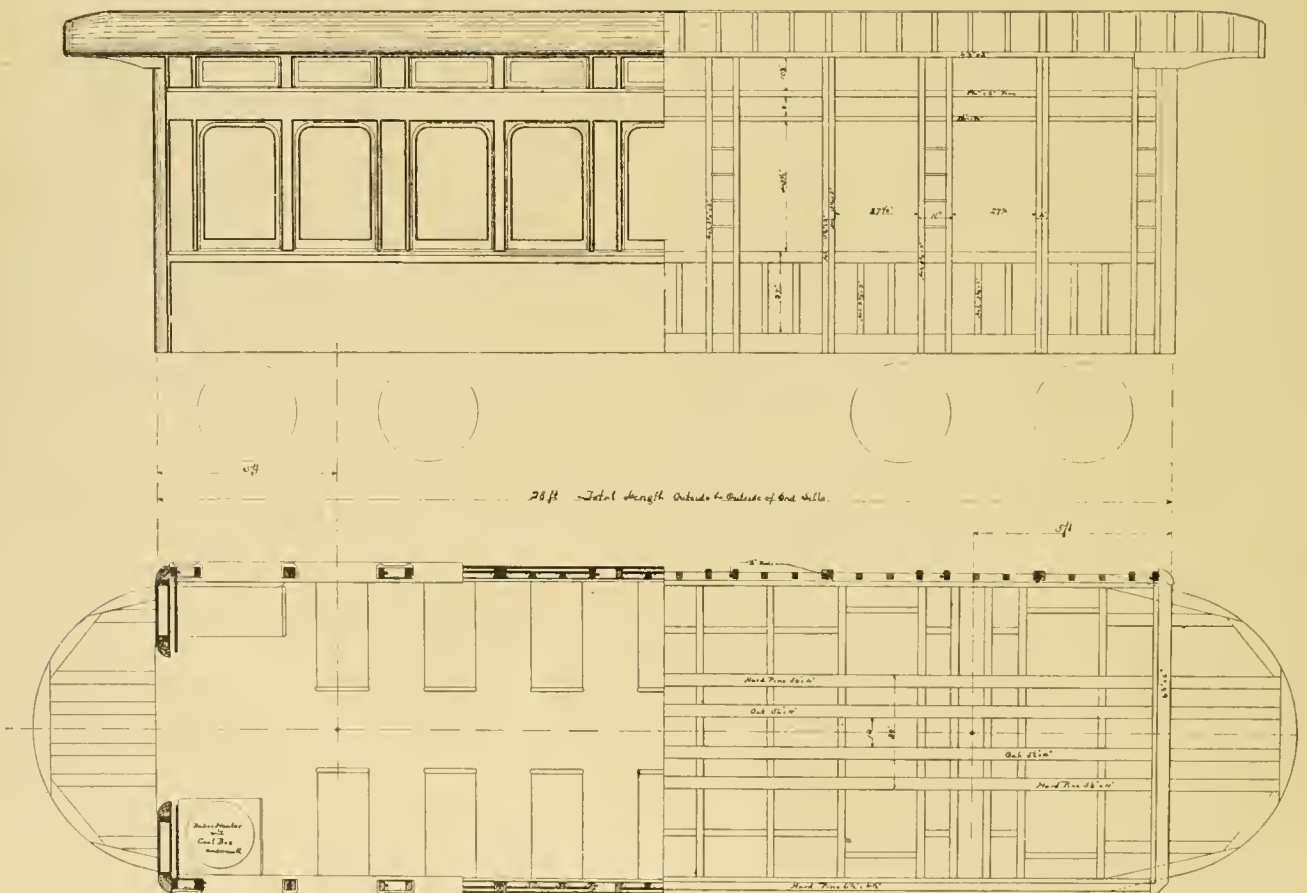

PLAN AND ELEVATION OF BREWER & KREHBEIL CAR.

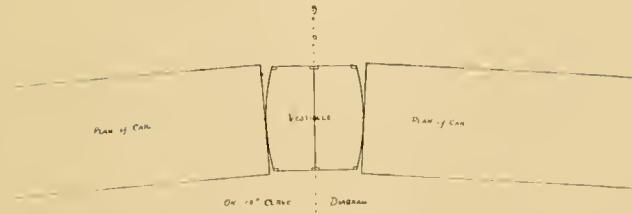

PLAN OF BREWER & KREIBELL VESTIBULE.

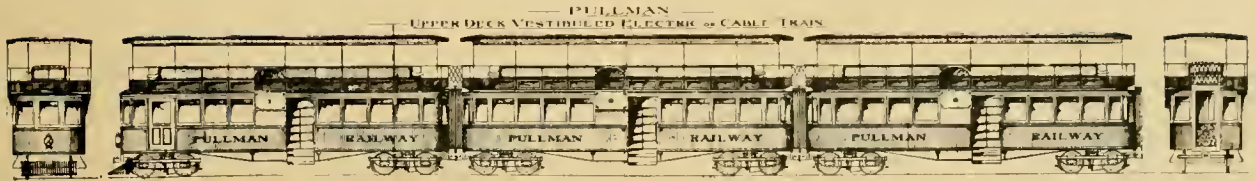

PULLMAN DOUBLE DECK TRAIN.

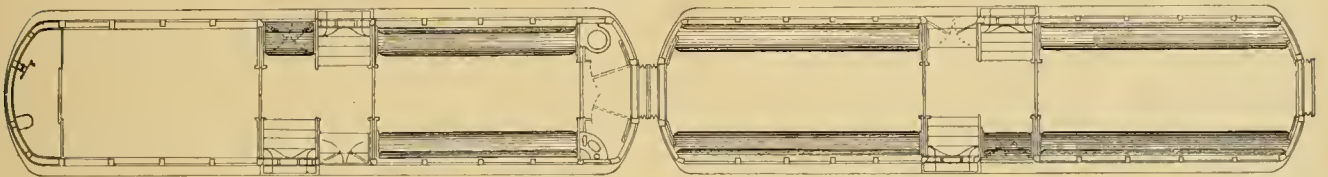

PLAN, PULLMAN TRAIN.



BARNEY & SMITH THREE CAR TRAIN.

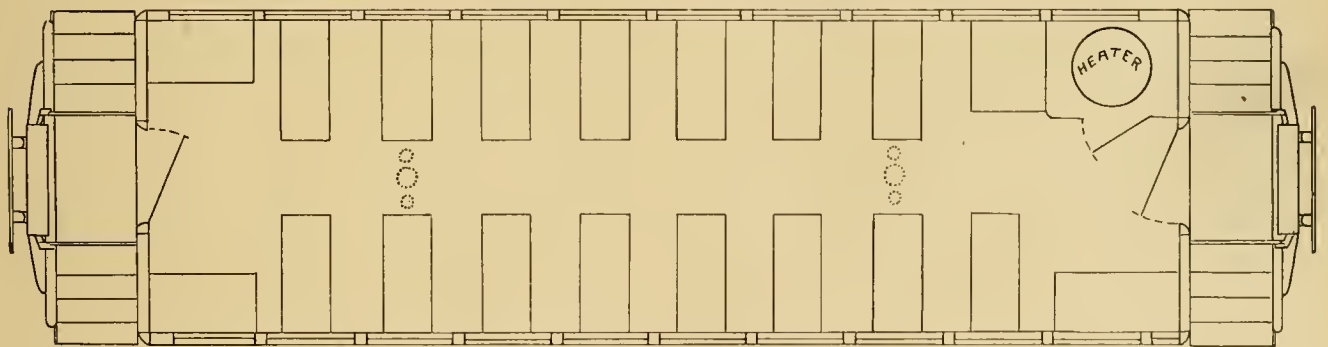

PLAN OF BARNEY & SMITH PASSENGER CAR.

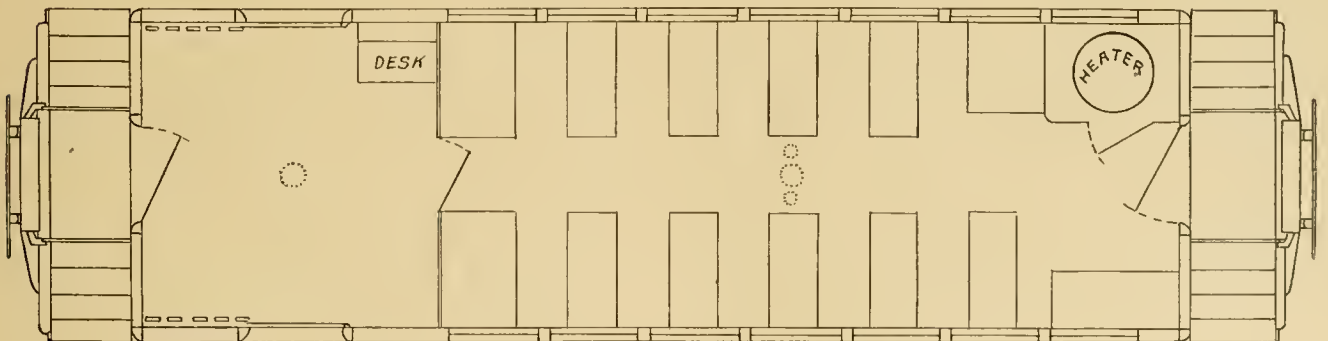

PLAN OF BARNEY & SMITH COMBINATION BAGGAGE AND SMOKING CAR.

## THE OHIO VESTIBULE DECISION.

Our readers have followed with much interest the various steps as recorded in these columns of the Ohio law requiring electric railway companies to vestibule their front platforms. The several methods adopted by different roads in an endeavor to comply with this law during the past winter have all been illustrated and described. While each manager has felt and maintained that the law as passed was unjust, and in most cases unnecessary and unwise, it remained for the Springfield Company to actually join issue with the State authorities, and since our last issue the court has passed upon the case. The ruling is of extreme interest and importance to all managers in northern latitudes, and we therefore print it in full herewith.

*Court of Common Pleas: Clark County, Ohio.*

The State of Ohio	Plaintiff,	
vs.		Decision on
Samuel L. Nelson.	Defendant.	Demurrer.

The following is the statute to which by the demurrers filed herein I am called upon to give construction, to-wit:

“An act requiring persons, associations and corporations owning or operating street cars to provide for the well-being of employes.

Section 1. Be it enacted by the General Assembly of the State of Ohio, that every electric street car or other than trail cars which are attached to motor cars, shall be provided during the months of November, December, January, February and March, of each year, at the forward end, with a screen constructed of glass or other material, which shall fully and completely protect the driver or motorman or gripman or other person stationed on such forward end and guiding and directing the motor power by which they are propelled, from wind and storm.

Section 2. Any person, agent or officer of any association or corporation violating the provisions of this act, shall upon conviction be fined in any sum not less than \$25 nor more than \$100, for each day each car belonging to and used by such persons, associations or corporations is directed or permitted to remain unprovided with the screen required in Section 1 of this act.”

It will be observed that the title is general as to street cars, and the body of the statute special to one class only of street cars.

There are several objections urged to this statute, only three of which, however, do I find it worth while to notice.

The first is that the legislature having conferred upon municipal corporations certain powers over the streets and highways within the limits of the corporation, and also the right to grant the use of such streets and highways for street railroads and to prescribe the terms of said grant, can only interfere with the same by a direct withdrawal of such authority, and that the power to so fix the said terms remains in the councils of such corporations to the exclusion of the right of the legislature to enact such a law as the one under consideration. As to this point, it is sufficient to say that the powers granted

under Section 3,443 of the Revised Statutes, can by no possibility have any reference to such provision as is set forth in this statute, being for a purpose not inconsistent with or repugnant to the powers granted in that section or in any other section of the statute. The phrase “terms and conditions” is limited to the extent and method of use of said streets and highways and the compensation which may be required for the exercise of such franchise by a street railroad company, and does not preclude the legislature from enacting such laws as it might otherwise rightfully do for the prevention of injuries arising from the running of cars upon such street railways.

Second. It is claimed that the above statute is unconstitutional for the reason, as it is claimed, that being class legislation it does not operate alike upon all the members of the class to govern which the same was enacted, in other words, that while it professes in its title to be for the benefit of all persons who may be employed upon street cars, by the express terms of the statute it is limited to such employes on electric cars, excluding from its operation such employes on horse or cable cars, thus making it appear upon the face of the statute a distinction which otherwise the courts might not give consideration to. A large number of authorities have been cited, and I have spent considerable time in examining and weighing the same, as applied to the above statute.

It is plain to even a casual reader that the said statute is incongruous in its provisions, owing entirely to the introduction of one word, namely, the word “electric,” by leaving out which we have a law applicable to all kinds of street railroads known to the people of our state, viz., horse, electric and cable cars, to the latter two of which, at least, trail cars are sometimes used, and the employes whose business it is to guide and direct the motor power, whether horses or mules, electricity or steam applied to cables, are specially designated in the words, “driver” for horses, “motorman” for electric cars, and “gripman” for cable cars.

A statute framed in that way being both in its title and in its provisions applicable to all kinds of street railroads, would upon its face be free from the objection named for the reason that as to the subject matter of said statute, viz, the protection of such employes, street railroads are sui generis, and no other kind of vehicles which are now upon our streets and highways have need of the appliances like those described in said statute for the protection of employes from “wind and storms” and hence as to such subject matter they constitute the entire class.

How the word “electric” came to be inserted in that section it is not known, but the question is as to the legal effect of such insertion. Does it make what was before fair and proper to be “unequal and partial legislation” as classed by Cooley in his work on Constitutional Limitations? It is claimed that a statute is not necessarily bad because of its being class legislation, but only when unequally applied as between persons of the same class.

The rule laid down by Cooley is that “if the law be unobjectionable, all that can be required in these cases is



that they be general in their application to the class or locality to which they apply and they are then public in their character, and of their propriety and policy the legislature must judge." "But," he goes on to say, "a statute would not be constitutional which should proscribe a class or party for opinion's sake, or which should select particular individuals from a class or locality, and subject them to peculiar rules or impose upon them special obligations or burdens from which others in the same locality or class are exempt."

The rule is stated somewhat differently by Justice Field in *Soon Hing vs. Crawley*, Chief of Police of San Francisco, 113, U. S., 703, as follows: "The discriminations which are open to objections are those where persons engaged in the same business are subjected to different restrictions or are held entitled to different privileges under the same conditions. It is only then that the discrimination can be said to impair the equal right which all claim in the enforcement of the law."

In *Van Riper vs. Parsons*, 40, 4 J., Law Reports, page 9, the Court say: "Interdicted local and special laws are all those that rest on a false or deficient classification; their vice is that they do not embrace all the class to which they are naturally related. They create preferences and establish inequalities; they apply to persons, things or places possessed of certain qualities or situations, and exclude from their effect other persons, things or places which are not dissimilar in this respect."

In *Froher vs. People*, an Illinois case reported in 31 N. E. Reports, page 400, the Court say: "Understanding our constitution as we do, it is impossible without disregarding its provisions to sustain a statute which makes that a misdemeanor when done by persons engaged in one branch of industry, which if done by persons in another branch of industry, in like relation and under like conditions, will be lawful."

Cooley on Constitutional Limitations on page 391, says by way of further statement of the rule, "Every one had a right to demand that he be governed by general rules and a special statute, which, without his consent, singles his case out as one to be regulated by a different law from that which is applied in all similar cases, would not be legitimate legislation, but would be such an arbitrary mandate as is not within the province of free government."

The last quotation is with references to privileges granted to or burdens laid upon individuals which are not awarded to nor imposed upon others, but is illustrative of the general principle lying at the foundation of all class legislation; that is, quoting from *Smith vs. Judge*, 17 Cal. 554, "that such laws shall bear equally in their burdens and benefits upon persons standing in the same category."

Neither is the case of the *C. B. & Q. R. R. Co. vs. Iowa*, 94 U. S. 155, reviewing a statute providing for different classes of railroads, different rates of charges, and frequently quoted in support of unlimited legislative discrimination in conflict with the principles above stated, for Chief Justice Waite in his opinion says: "It is very

clear that a uniform rate of charges for all railroad companies in the state might operate unjustly upon some," and hence that all the railroads in the state did not stand as to the subject matter of the law in the same category.

It is not necessary for me to review all the authorities cited, but only enough to gather some clear apprehension of what the courts and sound lawyers hold upon this subject; and we deduce therefrom the principle not that there may not be class legislation, but to use the language of the court in *Bronson vs. Oberlin*, 41 Ohio State Reports, page 481, "the classification must be just and reasonable and not arbitrary," and from the other authorities that "those engaged in the same business shall not be subject to different restrictions"; that the classification shall not be "deficient"; that it shall not "create preferences and establish inequalities; that it shall not discriminate against those engaged in one branch of industry in favor of those engaged in another branch of industry, "in like relations and under like conditions;" and that such class legislation "shall bear equally in burdens and benefits upon persons standing in the same category."

Coming to apply these principles, or rather this principle thus variously stated to the statute under consideration, what is the result?

Counsel for the defendant claim that the Court will take judicial notice of the various kinds of street railroads, and also of the character of the street cars running upon them, and of the appliances for running the same. The matters referred to are not within the range of matters ordinarily classified as subjects of judicial notice, but what is its equivalent, the Court cannot ignore in giving construction to a statute its own knowledge of such facts as are within the common observation and experience, not only of himself, but also of all other men. It will not ignore the common knowledge of men of the difference between an omnibus and a street car, and between the latter and a railroad locomotive; neither will it ignore the points of general resemblance in street cars, and whatever points of difference there may be, that all street cars have places of entrance and exit and the character of the same; that at least all horse and electric cars have upon the front of the same a place for the driver and motorman, who respectively drive the horses or apply the electricity to the moving of the car, thus in the language of the statute, "guide and direct the motor power by which the car is propelled"; that in so doing they are alike exposed to the weather, that they both alike, unless a screen is interposed, suffer from the storm and wind, that the pitiless rain, snow and furious blasts of winter at times render it almost impossible for men to endure the position, and that the circumstances of both require some protection.

But is there any more reason for the protection of one than for the other? Counsel for the state suggest but one, and that is that the electric cars move with more rapidity than horse cars, and hence that the motorman may suffer more. The difference is one of degree, and not of quality, and is of so slight a character as not to

bear analysis in the discussion of the question—"If a motorman needs the protection of a screen, why should not the driver of a horse car"? It is as if it being necessary to provide a cab for the protection of an omnibus driver, a law should be enacted to provide, under penalty, a cab for a four-horse omnibus, and leave a two-horse omnibus driver unprotected, on the theory that four horses would move a little faster than two horses, and so by a more rapid motion create a stiffer breeze, and thus produce a little more cold. I am not aware that it has ever been found necessary to provide a protection for engineers and firemen on railroad locomotives, for as long as I can recollect, such protection has been provided, probably voluntarily. But suppose there has been such necessity. We have had in this state in the past, three classes of steam railways, viz., broad gauge, standard gauge and narrow gauge. What would have been thought of a law which, general in its title to all railroads, provided a cab for the protection of the engineer and fireman of a standard gauge locomotive only, or for both standard gauge and broad gauge, leaving the narrow gauge out, on the sole claim that it could not make quite so fast time as the other two. The fact is, that the exposure for hours to the open air of winter is hard enough upon either motorman or driver, though there be neither rain, hail, snow or high wind, and it calls for some mitigation of the hardship. And that is what makes it difficult for me to decide this question. I am in sympathy with the law, but when the defendant challenges me by his demurrer for my opinion, I must say that I cannot see any substantial reason for requiring the screen provided in this statute for the motorman of an electric car that does not apply to the driver of a horse car. Let it be observed in this connection that this is not a vestibule law as it is ordinarily termed—the word "vestibule" is not used, but simply the word "screen," and not any particular form of screen is prescribed, so that the character of the screen is not in controversy, and the form of the screen can be varied to some extent to suit the different kinds of car upon which the same may be used. So that the question of the practicability of a vestibule is not involved. They are "in the same business"; they are in "like relations" to the cars which they respectively manage; they are under "like conditions" as to exposure to the weather; they are "standing in the same category," and if both are not protected from "wind and storm," there is a "preference" created—there is an "inequality" established, and the "benefits" of the statute do not "bear equally" toward such motorman and driver, whose relations, conditions, exposure and need of protection in the same kind of business, are so nearly alike in every respect.

The question involved is not now a matter of such common observation in this city as it was two years ago before the law was enacted, when we had both electric cars and cars propelled by mules, as still is the case in many of the cities of the state. Under such a law, in the severest winter, the motorman in passing by the driver of the mule car could have looked out from his

panoply of sheeted glass with the serenity of complete protection, and with a smile of contempt upon the storm-pelted and icicled mule driver. The poor muleteer might well have asked the legislature, why is this difference made between me and the motorman? And what kind of an answer would it have been for the legislature to say: "You must get a little more motion on those mules and we will. You are too slow to have any rights which we are bound to respect in this lightning age." For that is practically the argument of the prosecuting attorney.

Another objection urged to the law is that there is not by this law devolved upon any particular officer or agent of street railway companies the duty of providing the screens mentioned in the law. It seems to me that it is a question that goes rather to the practicability than to the validity of the law. It simply makes the work of the prosecuting attorney more difficult in finding out from the by-laws of the company, or otherwise, the responsible party as he has aimed to do in these indictments, by averring it to be the duty of the defendant as superintendent of the railway company to provide for them, which if he should fail to prove, would defeat the prosecution were the law valid in all respects. It only shows another reason why those interested in this law should send the same back to the legislature while it is yet in session, for repairs.

The consequences of this decision are not bad, and if they were, I have nothing to do with the consequences, for I am simply called upon for my opinion, and a judge is of no value who does not on questions submitted to him, render his honest opinion. The consequences are not bad, for the law can be remedied in a few days by the legislature striking out of the same the one word "electric," which I cannot keep from thinking was somehow surreptitiously and unobserved inserted by the great mass of legislators.

Again: I have less hesitation in rendering this opinion for the reason that there are eight of these cases pending in this Court, and if the Court should go on to try the same at great labor and expense, and then thereafter have verdicts set aside because of the question made herein, it would be much cheaper, easier and better for the prosecuting attorney to make up the record in this case now, which would be brief and inexpensive, consisting only of the indictment, the demurrer and a brief journal entry and have the same submitted to the Circuit Court which convenes in a few weeks, upon the legal question alone, and if my opinion is wrong we can have the other cases tried in June of this year free from any complications, except the simple one of fact as to the defendant's guilt in violation of said statute.

J. C. MILLER, J.

THE town of Halle, Germany, had a horse railway, which during the year 1891 gave a deficit of \$9,500 after two years' working. Then electricity was installed and its first year's service gave a surplus of \$12,000. The mileage was extended two and a half miles, and 2½ million passengers were carried.

**SAMUEL L. NELSON.**

THE portrait of the manager of the Springfield, Ohio, Street Railway Company, which single handed and alone has triumphed over the iniquitous and "granger" vestibule law of Ohio, is reproduced here. The face is a strong one with several good "fighting" lineaments.

Samuel L. Nelson was born June 23, 1859, on a farm near Hicksville, O., and gained his early education in the village. In 1874 he learned telegraphy and filled positions from operator to train dispatcher. In 1884 he became manager for the Central Union Telephone Company at Springfield, Ill., and later served the same office at Dayton, O. In 1886 he was appointed secretary and treasurer of the Electric Light and Water Company's plant at Champaign, Ill.,

but in 1890 left for McPherson, Kan., where he built the waterworks and electric light plant and became its vice-president. During the same year the purchase of the Champaign and Urbana horse-car line by W. B. McKinley put Mr. Nelson into street railway work for the first time. Later he became manager of the Defiance, O., electric light and street railway plant, and in 1892, in conjunction with Mr. McKinley, syndicated the Springfield, O., lines, of which Mr. Nelson assumed management. During the same year the two roads at Bay City, Mich., and West Bay City were purchased by the syndicate and Mr. Nelson made general manager. Such is the history of the successful life of Samuel L. Nelson.



S. L. NELSON.

**THE BATAVIA BICYCLE RAILWAY.**

The Batavia & Lake Ontario Elevated Railway Company is about to undertake the building of a one rail rapid transit system, designed by Captain L. Beecher, of Batavia, N. Y. J. W. Holmes, Batavia, is chief engineer.

The scheme is represented in our engraving, and opens itself to the fatal objection of top heaviness, especially at

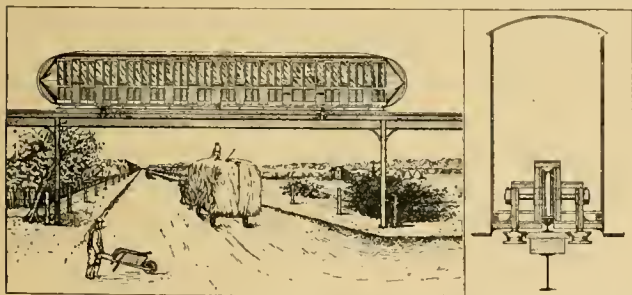

high speed. The car is to be 45 feet long, 3½ feet wide, and is to carry 40 persons. The motive power, as now determined, will be storage battery. The cross section shows the plan to be a center rail, bearing the car on a single wheel, with two guard wheels, to maintain the none too steady equilibrium. Captain Beecher makes the usual claims of bicycle elevated railway inventors.

**THE TRANTER FENDER.**

The invention of Benjamin Tranter, of 533 Park avenue, Brooklyn, N. Y., is shown in the accompanying engraving. It is a frame suspended in front of the car by hangers, and designed to be moved in and out at the car end. The front end of the frame runs on small wheels upon the track, while at the lower ends of the suspension rods are rollers against which the side bars of

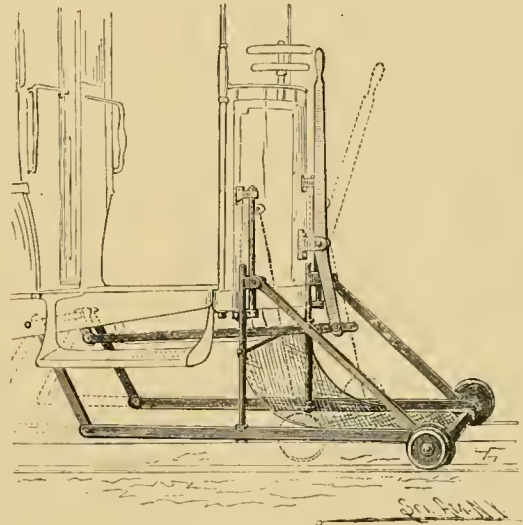

the frame move with little friction. The rear ends of these side bars are pivotally connected to swinging hangers on a transverse shaft beneath the car floor, and on this shaft is a crank connecting with a pitman pivoted to the lower end of a bent lever which acts as a handle by means of which the fender is raised and lowered for use by the operator of the car. The platform of the fender is a netting into which the person struck is intended to be "dropped."

**THE W. W. LIGHTNING ARRESTER.**

The W. W. lightning arrester, which has been in successful use for a number of seasons and is already well known, is one of the standard articles handled by the new Wallace Electric Company of Chicago. It is specially suited to street railway service, as it can be placed in buildings, on poles, or in cars, and is made in a very convenient form for all these uses. It has no moving parts to wear or rust out and is water and dust proof.

**THE VALE OF MINNEKAHTA.**

Is the title of a beautifully illustrated booklet recently issued, descriptive of the Hot Springs, South Dakota, and the efficiency of their waters for the cure of rheumatism, neuralgia and kindred diseases. Copy of this pamphlet will be mailed free by W. A. Thrall, General Passenger Agent Chicago & North-Western Railway, Chicago, Ill., upon receipt of request, enclosing two-cent stamp.

A NEW transfer ticket, of large size, has been introduced upon the Cleveland, O., Little Consolidated Lines.

## SOME WEST END RAILS.

The following article and the accompanying sketches are taken from an article by Superintendent of Streets Carter, of Boston, printed in Good Roads, the L. A. W. magazine. C. S. Sergeant, of the West End Street Railway, gave Mr. Carter the history of West End tracks.

Figure 1 represents the earliest form of girder rail for street railways. Its principal advantage was the fact that the fastenings were underneath the surface, and not subject to the jar of street traffic. This rail was laid on 4 by 6-inch stringers, the stringers being laid on ties four feet apart. Fastening used was a four-hole fish plate. This track would cost about \$9,000 a mile, with usual amount of special work, not including pavement. Rail now obsolete.

In Number 2, we see the next advance in girder rail, giving a 3-inch tram. It is 6 inches high, with a 4-inch base; laid on  $4\frac{1}{2}$  by 5-inch stringers, on ties four feet

The center bearing tram marked Number 5 became obsolete fifteen years ago. It weighed 45 pounds.

The last, Number 6, is for suburban use, weighs 35 pounds, and costs \$5,000 a mile. It is laid on cross ties. On some lines, sidings, and for laying at the side of the street, is its main usefulness on the West End. The street superintendent seems not, however, to be cognizant of the improved methods of paving to T rail, although he admits that a girder rail ordinance may be fatal to street railway enterprise in a small town.

As to the proper paving, Mr. Carter thinks that "it can be left to the city officials of the town," which proposition may be disputed in different localities, where unusual pig-headedness, denominated "progress" by the owners of the heads, wish a \$10,000-a-mile track and road bed construction on a \$1,000-a-mile street.

THE United States express has made arrangements to run into Ann Arbor, Mich., over the motor line.

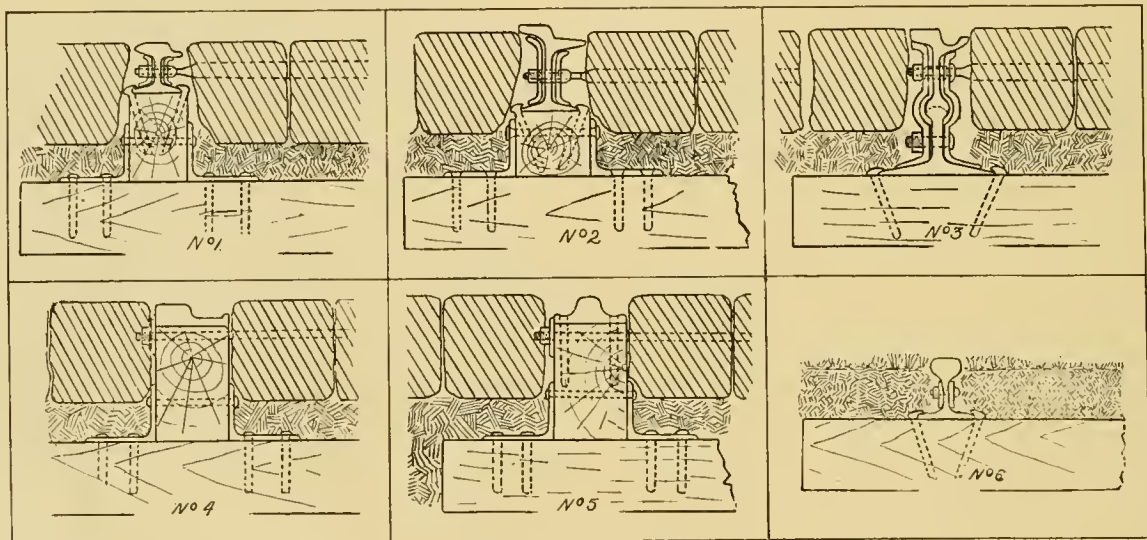

SOME WEST END RAILS.

apart; first, fish-plate fastening; afterwards 36-inch girder joint. West End has put in 6,000 of these fastenings in the past two years, none of which has as yet given out. This track costs \$11,000 a mile, exclusive of paving and special work. The rail is 78-pound.

Figure 3 is a new type of rail, used in the congested districts of Boston, ordered specially by the superintendent of streets. Its feature is the grooved head, which can be used only in constantly cleaned streets, where there is great traffic. This rail is laid with welded chairs, three feet apart, on ties with a channel bar joint, using two rows of eight bolts. The base of this rail is not rolled now. The estimated cost of this type is \$13,000 a mile, exclusive of special work and paving. It is an 86-pound rail. Its use is necessarily very limited. The groove is half an inch deep.

The next, Figure 4, was used exclusively by the best horse lines until within eight years. It was 50-pound, and cost \$8,000 a mile, excluding paving. It was laid on a stringer 5 by 8 inches, on ties five feet apart, and with a  $3\frac{1}{8}$ -inch steel plate, 16 inches long, under the joint.

A COMPROMISE has been effected between Congressman McGann, president of the Twenty-second street electric line and President Yerkes of the West Chicago, whereby the former is allowed to cross the tracks of the latter. By June 1 the new road expects to operate from Lawndale to Twenty-second street bridge.

A CHICAGO mail carrier who made a little "on the side" by walking and then selling the street car tickets furnished by the government has been dismissed from service by the Assistant Postmaster General. A heavy item of postoffice expense is street car fare, and the man should have returned unused tickets.

THE Westinghouse Manufacturing Company has removed its Chicago headquarters from the Pullman building to the New York Life building, at the corner of Monroe and LaSalle streets. The new quarters are on the seventh floor, south front, and are capacious and comfortable. The same working force and management is still in charge and all are pleased with the situation.

## OVERHEAD CONSTRUCTION.

Abstract of a Paper Read Before the Wisconsin Electric Club by  
O. M. Rau, Milwaukee Street Railway.

The overhead trolley line construction of the future will probably not show much improvement over the best construction of the present, as this class of work has nearly reached its highest development, and inventors are turning their attention to other fields. From the first little four-wheeled cart pulled along by the car (from which the present trolley received its name) to the present simple, substantial and reliable system is a great advance. but it must be admitted that little has been done to improve the appearance, the main effort being to make it safe and reliable. The appearance could be greatly improved by a little more attention to neat poles and wiring. The system of three years ago is as a flimsy spider web compared to the system of today. Number 0 trolley wire has replaced number 4 or 6, and heavy steel poles have taken the place of light gas pipe.

The matter of side or center poles is still under discussion. The first cost of the side pole is more, but the maintenance is less. The side pole is also a disadvantage at fires. Its main advantage is the limited cost of repairs, due to the flexibility of the system. The blow of the trolleys on the hangers is less and the life of the trolley wheels much longer. A thoroughly well constructed center pole system ought not to be any more expensive to maintain, with the exception of wear on the trolleys, than a side pole system. The danger from poles being close to the cars is very slight, and up to date not a serious accident has been attributed to this cause. Cars must be provided with gates, as the danger from jumping into a car on the other track is as great as that of striking a pole. If the gates are securely fastened there will be no accidents from this source. There is nothing that improves a pole line more than systematic construction. Iron poles should be set in concrete about 6 feet in the ground. Side poles should be set at 20 to 25 inches rake, and fitted with an insulating pole top of wood.

The trolley wire bell or insulator, of which there are about as many forms as there are men selling them, cause the principal expense in the maintenance of a trolley line. This should receive most careful study before a specific bell is adopted. Of the numerous forms the only satisfactory one from a financial standpoint is the metal covered one having the means for fastening to the span wire on the outside shell. The center pole has brought out several patent hangers having springs to prevent rigidity. Of the numerous forms I have tried, all have proved not only expensive but of little value in aiding the flexibility of the line. A fastening very much employed with center poles is the swivel joint, which allows the bell to hinge forward or back as the wire may draw it. This gives rise to many trolley wire breaks because an unbalanced strain will pull the wire out of line at the clamp, causing short turns in the wire which soon break. This plan of fastening was made necessary by the large number of clamp studs or screw eyes which

would break when the bell was bolted to the pole rigidly. The improvements made in overhead parts have changed this, as the screw eye and stud are either done away with entirely or increased in size so that they will stand any reasonable strain. When the bell is fastened as a rigid fixture and the trolley wire held firmly in it, each pole will receive its own share of the strain from the wire and need only take care of the span between it and the next pole. The clamp will then remain in line.

The choice between a mechanical clamp or soldered clip is a difficult one but is usually in favor of the former. The soldered clip, although the neatest in appearance and smoothest in surface, is expensive to put up and interferes considerably with repair work. In fact, any device which requires soldering is not to be recommended on a trolley system. The average lineman is not careful enough with this work, and will invariably heat his solder too hot, which will soften or anneal the wire. This is most noticeable with the soldered sleeve and over 20 per cent of the trolley wire breaks can be traced to the heating of the wires during soldering. Many clamps have too many parts or are too weak. Another point usually overlooked is the rusting of the threads of the screws holding the clamp. In numerous cases I have seen it necessary to cut the clamp loose from the wire. The stud in the bell should be not less than  $\frac{5}{8}$ -inch as this part is specially liable to break. On center poles the strain on this part of the hanger is very great and the number of patrol calls is largely governed by their strength. From the record sheets of a line having about 80 miles of road and 4,000 bells on center poles, it is seen that a total of 3,700 calls were recorded for the year '93-'94. Of these 3,230 were to replace bells on which either the screw eye on top or the screw stud on the bottom of the bell had broken. These were 7-16-inch in diameter. From this it is apparent that almost every bell on the system was replaced during a period of one year. With proper construction on a center pole system there should not be more than 100 calls per 1,000 bells per year or a depreciation of about 10 per cent, not including the value of bells taken down which can be replaced or used again, reducing this considerably. Brass has been used on the hangers but it is more expensive and far less strong than malleable iron. Corrosion is so small as to be left out of account. Number 0 trolley, the standard at present, was used on the first road. Silicon bronze has proven a costly line to maintain. With good road bed and rigid inspection the breaks should not exceed one per mile of double track road per year. The distribution of the current to an electric railway has not received the attention that it should. A great many roads simply take the ends of the trolley wires and connect them to the station bus bars and "let her go." On an extensive sectioned system it is an interesting study to equalize the potential and obtain the best results under the particular conditions. This I have done on the system of this city. By some slight changes, the drop, which was found to be 25 per cent on one feeder and 2 per cent on another was nearly equalized.

The advantages of having the line in sections are very important yet the only practical way to equalize the pressure over the entire system is to have all the feeders connected together as one large network similar to an electric light distributing system, where the mains would resemble the trolley wire. To obtain this advantage I placed a fuse box between each section with a fuse  $\frac{1}{4}$  of the carrying capacity of the main fuse on the feeder in the station. This fuse was fully capable of carrying all the current necessary to equalize the pressure between the adjoining sections and still light enough to blow if the station fuse was out.

Lightning protection is another important question. The Wurts tank arrester, in which the line is grounded through a tank of water, has proved very efficient at the station.

In closing I will say that although the overhead trolley system has been abused, and it is often remarked that it has seen its day, the next generation will see more overhead trolley lines constructed than any other system and for cities of 200,000 or less population it has come to stay.

#### CHANGE OF POWER STATIONS AT LAFAYETTE.

Since the REVIEW representative visited Lafayette in January 1893, the power house of the Lafayette Street Railway has moved itself—no, that is not right, Manager Hill would never admit that it moved itself—has been



THE POWER HOUSE.

moved, into new quarters and the plant presents a very different appearance from that of a year ago. An elegant new car barn has also been built. Our engraving shows the new power house, with the old power house made over into a house for the engineer, in the foreground. The change of power houses was effected without a moments delay of traffic. The new engine room is 75 by 55 feet and the boiler room 55 by 35 feet. The steel stack is 125 feet high, built by the National Boiler Works of Chicago. Two 250-horse-power Sterling boilers are giving splendid satisfaction and have in General Manager

Hill a firm friend. They are fed through a 500-horse power Stillwell-Bierce feed water heater, by two Marsh steam pumps. In addition to a 130-horse-power Hamilton Corliss, moved from the old station, there is a new one of 250-horse-power. These are belted to a line shaft,

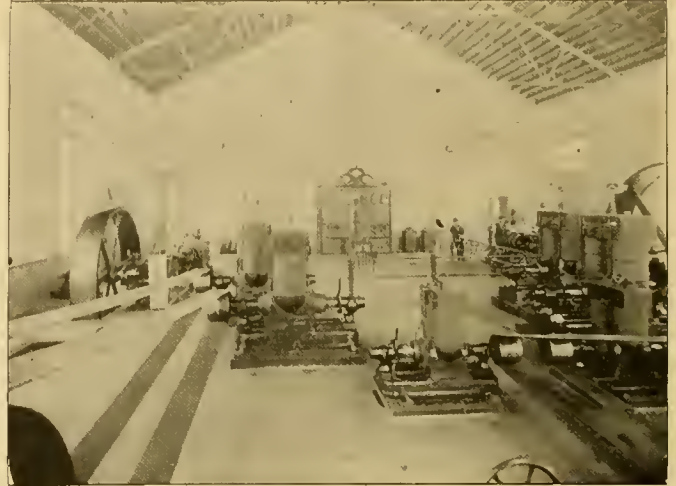

INTERIOR OF STATION, LAFAYETTE.

which is supplied with Hill clutches for throwing off and on the different machines. Munson belting is used throughout. There are two 100-kilowatt and two 50-kilowatt Edison railway generators and two 250-volt generators for stationary motor work. The station uses natural gas as a fuel, which is piped from the Indiana gas

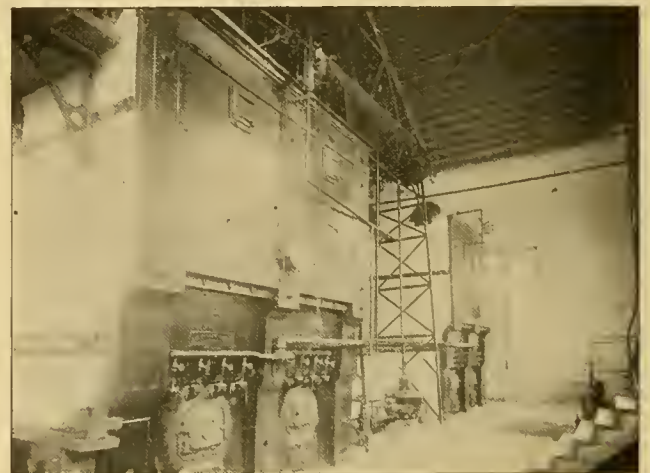

BURNING NATURAL GAS.

fields, 40 miles from Lafayette. The pipe line pressure is from 160 to 200 pounds. At the city limits it is reduced to 25 pounds. At the center of the city it is again reduced to 2 pounds, for domestic use. For use under steam boilers the 25 pound pressure is continued into the boiler room, where the pressure is automatically regulated by the steam pressure. The meter rate for this gas is 7 cents per thousand feet. Mr. Hill says that this is 50 per cent cheaper than the best coal, including the cost of firemen, which are not required. However, they stand prepared during the extreme cold weather to start a

coal fire when the gas supply is liable to be shut off. The gas pressure at the boilers varies from  $\frac{1}{2}$  to 2 pounds. The boiler room is as clean as a parlor and is scrubbed out every day. A home made burner is being used



CAR HOUSE, LAFAYETTE.

under the boilers with good results. A 3-inch pipe connecting to the gas meter is carried along in front of the boilers and is tapped with  $\frac{3}{4}$ -inch pipes, provided with globe valves, as seen in the engraving. These  $\frac{3}{4}$ -inch pipes lead into elbows attached to 3-inch pipes, extending through the boiler front. On the ends of the  $\frac{3}{4}$ -inch pipes are caps having a large number of small holes. These spray the gas into the 3-inch furnace pipes and allow it to mix with the air entering those pipes, thus securing good combustion.



INTERIOR CAR HOUSE, LAFAYETTE.

The new car house is 126 by 96 feet, having seven tracks and room for 32 cars. The transfer table is across the center. Offices, machine shops and waiting rooms are located in this building and also means for the incandescent lighting of the building.

During the last year over five miles of track have been laid with 56-pound T rail, and more will be built the coming spring.

## SPARK ARRESTERS NEXT.

The daily press report a singular accident whereby two men working on natural gas pipes in a trench, were badly burned by the ignition of leaking gas, which was set off by a flash from the wheels of an electric car passing above. We presume this adds one more head to the deadly trolley monster.

## "ALL IS FAIR IN LOVE AND WAR."

The arrest of one George L. Ward, in New York city, brings out a story of competition. Ward had been haunting Third avenue just below 125th street, and hailing nearly every uptown cable car. When the car stopped Ward would count the passengers, glance at the fare register and walk away. His arrest and a fine of ten dollars brought out no word except that he was curious to know how many people were in the car. He is thought to be an employe of the Third Avenue Elevated and to be gathering traffic data.

## REQUIREMENTS FOR A CAR FENDER.

The small army of fender men, both present and prospective, will be interested in the following which is furnished by one of the most experienced managers in the country as embodying, what in his judgment constitutes a good street car fender. He says:—

"It must always be in position, ready for emergencies, must not depend upon any act of the motorman, because in emergencies he often gets excited and confused, and would forget to do his part. It must travel near the ground in order to pick up a prostrate person or child, and should not be so constructed that the fender itself could run on to and crush the person. As it must run near the ground in order to be reliable, it follows that when the car plunges, as all of them will, and the fender strikes the ground, that it shall not be broken or injured thereby, though it so strike the ground hundreds of times each day. It must be light, decidedly strong and reasonably cheap. It must be adjustable to any kind of car, simple and easily repaired, therefore it should be made to templates, so that repairs can be kept in stock. It should be easily and quickly removed and put on, so that it could be done right in the street. It should hang so that in collisions with cars, or when one motor is called upon to haul another, back or front, the fender is not in the way and is not injured thereby. It cannot be practical if not strong enough to collide with buggies or wagons without injury to it. It should be made of steel or iron and have no perishable parts of rope, wire netting or canvas. It should add to rather than detract from the appearance of the car. If it hinders the handling of cars in the barns, transfer sheds or shops it is impracticable. The demands upon the elements of an electric street railway system are such that there is no time to waste on impractical devices. I will never adopt a fender for the system under my management which does not, at least, come up to the above specifications."

## HIGH VS. LOW SPEED ENGINES.

Reply of President Green, of the Altoona Manufacturing Company, to C. P. Young, in March Street Railway Review.

*Editor Street Railway Review, Chicago, Ill.*

DEAR SIR:—I notice on page 184 of your last issue, an answer from Mr. Young to my letter of inquiry as to his open letter in your December number, in which he stated, an engine running above 120 revolutions a minute should never be used for electric railway work. Now, Mr. Young, in answer to my inquiry states, in his letter that he did not write the article for the benefit of engine manufacturers, but for the presidents and directors of street railways. So I take it for granted that Mr. Young would gladly have deceived the presidents and directors of street railways, and, by so doing, would expect engine builders to adhere to the same deception. I do not say this with the view to use any slighting language, as Mr. Young has done, simply because I asked for information. In the first place, I wish to say that in answering my inquiry Mr. Young has departed entirely from the text from whence he drew his former letter. He now only goes on to ridicule me for asking the questions, by saying he supposed he has stepped on my corns, etc., and would now endeavor to shield himself behind the theory of economy between high and low speed, and, in endeavoring to shield himself behind the walls of economy, he cites to the problem of a 1000-horse-power station, which is not common to the general public, as, it must be remembered, there are one hundred small stations with less than 1,000-horse-power where there is one station with as much as 1,000-horse-power. But let that be as it may, he says that a 1,000-horse-power station uses twenty tons of coal per day, as against another power station of the same capacity using twelve tons of coal per day; then he makes a comparison between the two, which would leave a difference of eight tons per day. Now, to make such a comparison as this without giving any data, is simply ridiculous. It might be possible that such a margin might exist, provided one power house was equipped with triple-expansion condensing engines, while the other power house was equipped with single cylinder non-condensing engines. He further tries to impress us with the fact that the slow speed engine is newer than the high speed engine. It may have been in the country where Mr. Young came from, but I am sure it is not in this; and if Mr. Young imagines he is bringing to light some new idea to induce people to use slow speed engines, I am sure the slow speed engine, as above stated, is no new thing.

In regard to regulation, he claims that the regulation of a high speed engine is two per cent between minimum and maximum load, while a slow speed engine, he claims, will regulate within one per cent. It is thoroughly understood and acknowledged by all practical and scientific men that the higher the speed the closer the regulation; and that a high speed engine as a rule is far superior in regulation where the load is constantly changing, to a slow speed engine; for the nearer the engine becomes the speed of the generator, the less the generator changes relative to the engine in regard to speed. For instance, a high speed engine running 250 revolutions a minute, belted to a dynamo running 1,000 revolutions a minute, the ratio of speed is four to one; while a slow speed engine running 100 revolutions a minute, belted to a dynamo running 1,000 revolutions, the ratio would be ten to one. So you see that if both engines were to regulate the same, the generator would increase and decrease double in its speed with

relation to the speed of the slow speed engine from what it would with relation to the speed of a high speed engine. So that from that standpoint alone, the high speed engine would be preferable for close regulation, for it is the generator we look after for regulation.

A high speed engine is especially adapted for railway work, for the reason that a high speed engine running 250 revolutions a minute, and say we suppose it to be 150-horse-power, running a railway where the units are few and the grades are great, the engine has to respond from nothing up to full load, and vice versa, continually. Now, the shock of 150-horse-power coming in upon an engine will be divided by 250 revolutions per minute, which would average about .60 of a horse-power per revolution of speed. While an engine running at 100 revolutions per minute, and the shock of 150-horse-power coming in per minute, it would be 1.5-horse-power per revolution per minute. So it seems that this alone is in favor of the high speed engine. It is a fact (and facts are stubborn things) that in all the motions the greater the number of revolutions per minute to produce certain power, the less strain and shock there is per revolution. I will endeavor to show that a slow speed engine will not regulate with a high speed engine from a practical and common sense standpoint. To begin with, I have shown clearly that the slower the speed the greater the shock will be per revolution; and taking Mr. Young's own comparison, it shows more than double. For instance, a slow speed engine is running absolutely light; the piston has started on its journey toward the opposite end of the cylinder, and the valve has opened and admitted sufficient steam to carry the piston to its journey's end with the existing load; the trip has let go and the valve has closed. At that moment there is flashed in 150-horse-power, and the engine running at only 100 revolutions a minute, there is no alternative but the speed will decrease considerably by the time the piston has reached its journey's end; then the governor will have dropped down, and the piston will receive a blow of the full boiler pressure, which is inclined to send the engine above its normal speed. In a well designed high speed automatic engine, it is possible for the valve to re-open and admit additional steam, provided the load is constantly changing. We have made many tests on both high and low speed engines on railway work and on electric welding work, and we have proven without a doubt that a high speed engine is far superior to the low speed engine where the load is constantly changing. Another reason, that it requires less than one-half the time to make a revolution, so that if the valve would not re-open the advantages are double in favor of the high speed.

Further, Mr. Young attacks the high speed engine as to its durability. To this I wish to say that an engine running at 250 revolutions a minute does not require as fine adjustment of the bearings as an engine running 100 revolutions a minute, for the reason that we use on high speed engines a certain amount of compression that arrests the reciprocating parts, forming a cushion as they pass the centres; and an engine running at this speed seems to have no dead centres, producing a smooth rotary motion, equal to a turbine wheel. An engine running at 100 revolutions a minute seems to check upon the dead centres, and unless the reciprocating parts are finely adjusted will hammer when passing each center. I am well aware there have been engine builders who build light flimsy engines and have tried to reach a point of speed far beyond the ability of their engine, and of course they have come to grief. Every engine builder in this country aims to run his engine just as fast as he has found it will stand; and the Corliss type of engine which you seem to favor so greatly, would be run much higher in speed but unfortunately the



construction will not permit. I am quite sure that if as many high speed engines had come to grief as have slow speed engines, destroying as much property and causing as much loss of life from the bursting of fly wheels, etc., they would have been cried down long ago. Mr. Young would now put forth an idea, which is ridiculous, to make the large fly wheels of the slow speed engines of malleable iron, which would mean enormous furnaces to be able to anneal such wheels. Now, if it requires all such unnecessary expense simply for the sake of securing the slow speed, and when you take into account the additional expense, room, counter shafting, keeping up of counter shafting, large belts, etc., why do we want to go to this expense to secure something that a high speed engine will furnish with one-fourth the room, expense, annoyance, etc.? While I will admit that the high rotary motion of the high speed engine compared with the slow speed engine (provided each shaft were equally loaded) would be greater than the slow speed engine, yet when you take into account the enormous fly wheels that have to be used on slow speed engines, the friction per square inch is reduced in favor of the high speed. Now, if Mr. Young had come out in his first letter and said that large power stations that would use 1,000-horse-power and upwards should use 500-horse-power engines, which of course would only run from 100 to 120 revolutions a minute, were preferable to putting in ten 100-horse-power high speed engines, then I should have never asked for the information; but he failed to do that, as he does now; he simply wrote his letter covering the whole ground in saying that no engine was fit for street railway work that run over 120 revolutions a minute. For in a large power station operating a street railway, where 1,000-horse-power is required, the units of power is so great in number (that is to say, there are so many cars on the line being operated at the same time) that the engines do not feel the shock of the cars letting go and taking hold alternately, as there are always sufficient cars moving to produce practically a steady load upon the engines. But as stated before, there is only here and there a power station equipped where it requires 1,000-horse-power. There are many railroads running to-day in America (and we have equipped many ourselves) that only require from 100 to 200 horse-power engines; and as stated before, the units being few and the grades heavy, I have in many cases noticed the power would change from nothing up to full load constantly. For instance, the engine was 200-horse-power, a portion of the time it would only be working say 50-horse-power, and then the next instant it would be called upon to furnish 200-horse-power.

In regard to economy, this depends on a variety of conditions, one of which the high speed engine has exclusive possession of, and which I will endeavor to explain. The great cause of loss of heat in the cylinder is the condensation of the entering steam upon the surfaces which have just been chilled by the re-evaporation of the water formed by the previous condensation. We shall see that on a given extent of surface and under given alterations of temperature, a fixed amount of condensation and subsequently re-evaporation must go on a given time. It follows, that the greater the quantity of steam worked through a cylinder per minute the less will be the percentage of loss when this condensation comes to be divided by the whole quantity. Many experiments, among them some of a very striking character, have proven the truth of this. It is found to be easy to condense nine-tenths of the entire steam, or indeed any proportion whatever, by running an engine slowly; on the other hand high speed means economy. Again, in a high speed engine superheating is more efficient and a less degree of it is required. This is

obvious, since to prevent a given condensation, and consequently re-evaporation, it is necessary to bring into the cylinder a given amount of superheat per minute, and as the quantity of steam brought in increases with the speed the degree to which this temperature must be raised in order to do this, diminishes in the same proportion. The most startling truth of this fact also is obtained by running an engine very slow when no amount of superheating avails to prevent condensation, in a degree increasing just as the speed is reduced. The high speed engine, if properly built, enables us to secure in the construction of the valve gear a compression at the end of each stroke which completely fills the entire clearance. On the other hand, the slow speed engine would be allowed to exhaust into the air, and new steam would be required to fill up the clearance space and reheat the surfaces.

Now, as it is acknowledged by all, that condensation is the greatest enemy to economy in steam engines, and as it requires more steam to heat and maintain a certain degree of heat on two feet of surface than on one foot, I will simply give an illustration. A slow speed engine to produce 100 horse-power, having cylinder 16" diameter and 42" stroke, would contain 8,444.62 square inches. While to produce 100 horse-power in a high speed engine the cylinder would be 13" bore and 12" stroke. This cylinder would contain 1,594.79 square inches of surface to be heated. So it is plainly seen that there is a fraction over five times as much surface to be heated on a slow speed engine as on a high speed engine; and as above stated, as condensation is the greatest enemy to economy there is no question to be discussed along this line.

Now, as Mr. Young came out in his first letter and made an assertion I asked him to give his reasons why he made such an assertion; he gave me his reasons and I now answer him, and have endeavored to set forth the advantages of high speed engines over low speed engines for street railways; and as we have both given our opinions on the subject I propose now that the public shall judge for themselves who is right and who is wrong, as life is too short to waste any more time on the subject. For there are lovers of slow speed engines and there are lovers of high speed engines, and there are places for slow speed engines and there are places for high speed engines; and it don't matter what Mr. Young or myself might say in regard to them, the lovers of each kind of engine will continue to float in the same channel. For it must be remembered that the "mills of the gods grind slowly, but they grind exceeding fine."

M. A. GREEN.

#### A NOVEL WHEEL.

In France, the ingenious plan has lately been adopted of making wheels for cars by bending up seven pieces of bar iron in such a shape that the center fits inside of a hand or false felloe, which, in turn, is hammered into a groove in the tire, felloe and tie being riveted together, the cars bent round to the center of the wheel, their ends having a model placed between them; cast iron is then run in, forming the hub, which is afterwards bored out, and the cast steel axle forced in by some fifty-five thousand to sixty-six thousand pounds hydraulic pressure, and the life of the center of the wheel is said to be practically interminable under ordinary conditions.

HAMBURG, Germany, has a street railway on the electric plan.

## A BONDING CHUCK.

The latest addition to the list of bonding devices is the "bonding chuck" made by Stern & Silverman, 707 Arch street, Philadelphia. It necessitates the cutting of threads in the hole in the rail. The chuck having been screwed in tight, the bond is placed in the split end, and the nut

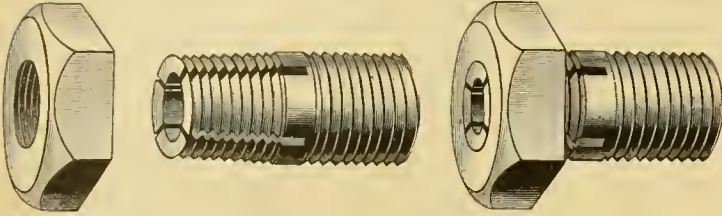

screwed up until the three segments are brought together so as to clamp the bond. The labor required to install these bonds is somewhat more than that with other forms, but once put in, good contact is absolutely certain, and the cost will still be less than that of heavy copper feeders.

## THE BARROWS ELEVATED ROAD.

In this system the inventor has in mind the cheapening of the elevated structure so as to make it practicable for cross country construction, and cheaper than building a surface road with cuts and fills. Instead of having the ordinary rails, a part of the weight of the train is taken by the flat tired wheels running on the girders, which girders are a necessary part of the elevated structure. The cars are held on the track by the central double flanged wheels. The motors are

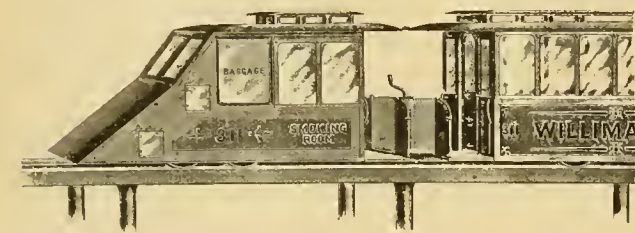
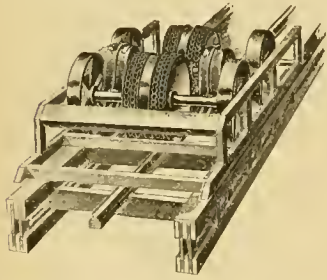

geared by sprocket chains as shown in the engraving. The inventor claims that a single track country line can be built for \$2,000 a mile.

THE Mohntonville & Adamstown (Pa.) Electric Railway will be constructed on a new plan. At least new for electric railway work. It is a reminder of primitive days of railroading and road building. No bonds will be issued, but farmers along the way are to furnish labor, teams, wagons, poles and ties, taking stock of the company in part payment. If the plan is a success, it ought to greatly increase the possibilities of country electric roads.

## THE STILLMAN TRACK.

The Stillman system of track, is simply a T rail with the base left off. The track is laid by inserting the web between two wedge shaped stringers. The stringers are made by sawing through a square timber as shown in Figure 3. The stringers and rail are firmly bolted together and tie rods placed frequently. It is claimed that this construction is specially adapted to a continuous welded rail. In this system the ties are placed several feet apart. It has been found that with a track so laid,

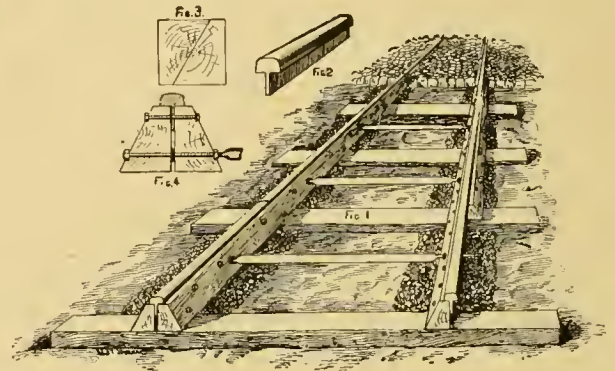

the rail becomes so tightly forced between the stringers by the wedge-like action that they are separated with difficulty. In a trial of eighteen months on a steam road some track laid without fish plates showed one-eighth inch drop at the joints. Since then a light fish plate has been added. H. L. Stillman, of Kenyon, R. I., is the agent.

## ACCIDENT INSURANCE.

Since the introduction of mechanical traction the matter of street railway insurance has become an important one in practical railroading. But a few years ago the practice of insuring the management of a horse cable or electric road, became an entirely new feature in accident insurance and the numerous agencies and brokers for nearly all of the accident companies were active in their efforts to obtain these risks. The amount of the premium charged was based on the annual gross earnings. These premiums were from  $\frac{3}{4}$  of one to  $2\frac{1}{2}$  per cent. of the gross traffic earnings, being determined by the condition of the road, ability of the management and its previous record. In the majority of instances the contract provided for a limit of \$15,000 to \$25,000 for any one accident, no matter how many persons might be injured, and not more than \$5,000 to any one person injured. Experience has taught that this class of business is not very desirable from the underwriters standpoint, and as a result, in some circumstances they have declined to renew these policies except at a much greater premium and in other cases have sought to avoid liability by a procedure which looks very much like a repudiation of the contract. The Utica Belt Line has recently developed an important question in this regard. A five years policy was taken out by it in the Travelers of Hartford. It was to run five years and the premium was a per cent of the gross

receipts. The policy was dated September 28, 1891, and on September 1, of each year, the railway was to give the insurance company a statement of its earnings and throw its books open to the inspection of the insurance people. The second year of the policy a statement was requested by the insurance company and was furnished by the railway. The premium was computed therefrom by the insurance company and a bill sent the railway which was promptly paid. The statement of earnings was requested and sent again the third year, but the insurance company remained silent and sent no bill. Soon the railway wrote the insurance company asking a statement but received the reply that as the policy was dated September 28, and had not been paid by that date it was no longer valid. The Belt Line management then made legal tender of the premium computed from the traffic earnings as required by contract. Nothing of the nature of an accident had occurred in the meantime which would appear to justify the Travelers in refusing to accept the premium. The Belt Line claims that the insurance company is trying to crawl out of its policy by taking advantage of a technicality regarding the time of payment, having established by its act of the previous year a wrong and misleading precedent.

It is only fair however to state the other side of the case which is presented with sufficient strength by the following letter from the president of the Travelers Insurance Company.

HARTFORD, CONN., Feb. 13th, 1894.

EDITOR STREET RAILWAY REVIEW:

The copy of a statement made by the Utica Belt Line Company, which you send me, is unfair and in the most essential points untrue. It was an annual policy, renewable each year for the term of five years, on condition, that at the close of each year the premium for the next year should be paid in advance. The amount to be paid was a percentage of the gross traffic earnings, which amount was known to the railroad company and unknown to the insurance company. The computation could be made by any clerk in less than two minutes, and was not "presumably" the duty of the insurance company, but "presumably" the duty of the railroad company, which alone had possession and control of the data at the time when it was to have been made.

There is no dispute about the first and second year, and the insurance company has paid and continues to pay the losses for those years.

For the third year, the author of your letter says that he received a letter requesting the statement of traffic earnings for the year, which statement he says was made, but he does not give you the dates. The payment was due September 28th, but as he neglected until October 20th to notify us that he was "ready to pay the premium," and allowed the policy to lapse, we claim that its continuance is therefore optional with the insurance company and not with the railroad company. If they had the right to continue they lost it by their own neglect, and not by any act of ours.

The Travelers Insurance Company will fulfill its obligations to the utmost; but when a bankrupt corporation neglects to fulfill its part of the contract, we shall retire from the wreck as speedily as opportunity will permit, pay our losses, and have done with it.

If the managers of any other road think that we are "sneaking out of our contract," for the reason that we will not allow this road to pay premiums whenever it sees fit to do so, regardless of the contract, they have only to express their displeasure by requesting us to return the unearned portion of the premium paid, and give their patronage to some other company, whose business requirements are less exacting than ours.

J. G. BATTERSON, President.

#### THE RELATION OF VOLTAGE TO SPEED AND TIME TABLES.

Has the superintendent ever thought of the relation the few units of electrical pressure carried on the trolley line bear to the time table? These two items are apparently very far apart, but they have an essentially vital relation to each other, and the relation is briefly expressed by the well known rule; the speed varies with the voltage.

One of the most economically operated small roads in the country has reduced its voltage from 500 to 400. The reasons for the change were excellent and should be considered by every road operating under similar conditions.

The problem presented to the managers of the line was as follows: The system consisted of a number of single track routes and a five mile interurban. Being a small city it was necessary to run cars on a certain schedule time, and to save complications it was important that cars should make trips on the even divisions of the hour, in the majority of cases every 20 minutes. It was found that the time required to make a round trip was something less than 20 minutes, yet it was not practicable to increase the speed sufficiently to make round trips every 15 minutes. The 20 minute schedule being adhered to and the waiting time at the termini being excessive, the question arose; why not lower the voltage and decrease the speed of cars? It was found that the running time of of all the lines including the interurban favored this move, and consequently the voltage was lowered 100 volts. The fuel consumption was, as a result, very noticeably lowered. This is as would be expected, as it is well established that it takes less energy to move a car a given distance at a low than a high speed. In addition to this the wear and tear on motors and their insulation is less the lower the speed. It may be argued that lowering the speed is a step backward and that the tendency is toward higher speeds. While this is in general true, especially on long lines, it has little weight in the case under consideration. On the other hand there may be places where a slight raise in voltage would be desirable.

## TROUTING BY TROLLEY.



GOING fishing is the easiest thing in the world for the sportsman of Tacoma. All he has to do is to rise early, catch his breakfast, grab his rod, run down to the corner, board the first car and in twenty minutes is landed at Chamber's creek. Ten minutes later he is thrashing the water, alive with trout that rise to a No. 2 Royal Coachman as though they had never snapped at a fly before in their career.

This method of inducing traffic we particularly recommend to managers just outside the larger cities. A fine trout stream and some primeval forests may easily be had.

## ANOTHER LONDON BUS.

The country is saved again. Clubbe & Company of London, have an electric bus which will operate (on paper) at a cost of 5 cents per mile. Yea, even more than this. The company is prepared to "undertake contracts to build and run full sized tram cars carrying 46

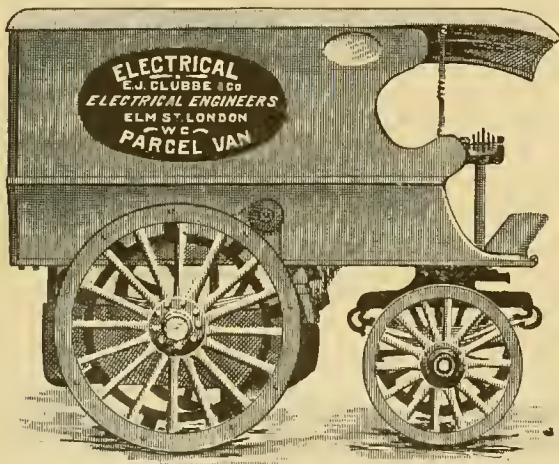

THE ELECTRIC BUS.

passengers, speed—up to 8 miles per hour—the cost of electrical force being 1.5 cents per mile when generated by steam power at 2 cents per unit." We fear that the company will not do much more than "undertake." When a storage battery has been found that can do good service on a street car running on smooth iron rails and moderate grades it will be time to seriously consider the electric bus for paved streets.

THE Lake Street Elevated, acting under a court decision, began extending its line from West Forty-eighth street, Chicago, to West Fifty-second street. The trolley wire of the Cicero & Proviso Electric Railway was disconnected, to make way for the construction, which occupied but thirty minutes and hardly disturbed the 10-minute schedule of the electric cars.

## THE LAWRENCE CONDUIT.

One of the few systems which entered for the Metropolitan Traction prize with a section of track in actual operation, is the invention of William Lawrence, of Wilmington, Del. The section of track referred to is located in the yards of the Harlan & Hollingsworth Company, of

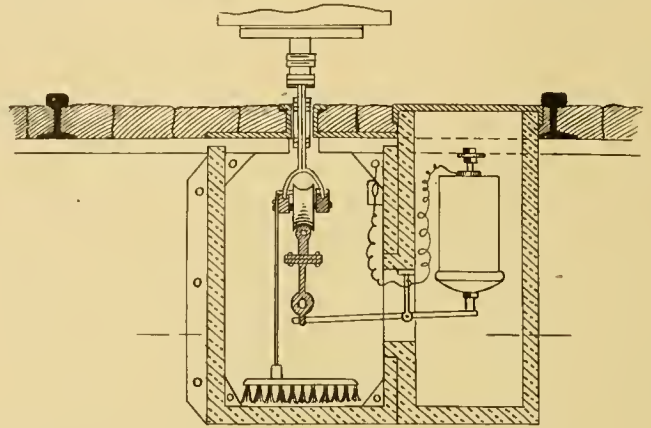

THE LAWRENCE CONDUIT.

Wilmington. The accompanying engraving shows a section of the track and conduit as arranged for a single track loop. It is slightly modified for double track. The trolley conductor is a girder laid in 32-foot lengths and supported at either end by levers attached to junction bores as shown in the section. The weight of the trolley on the girder causes a connection to be made in the junction box, throwing the section which the trolley is on into circuit.

## BRACEY'S IMPROVED RAILROAD SPIKE.

The spike herewith illustrated is the invention of Smith H. Bracey, Monadnock Block, Chicago. It is undoubtedly a great improvement over the ordinary spike, claiming these advantages: Its head is not broken nor spike fractured in the operation of driving. It cannot be canted on or pushed outward by the outward pressure of the rail caused by the flanges of the wheel. It thus prevents spreading of the rail. The spike consists of a rectangular body with a driving point at the lower end and an enlarged head at the upper end, forming inner and outer shoulders, the outer shoulder being arranged below the inner shoulder, agreeing with the thickness of the rail. Thus the outer shoulder forms an anchor and blows upon the spike will not break the head on one side or fracture the body of the fastening.



THE Bellaire, Bridgeport & Martin's Ferry Electric Railway, in Ohio, enjoyed a little strike during March. It lasted but a few days, and ended by the men accepting a 1 cent per hour reduction in wages.

## EXPERIENCES OF A SUPERINTENDENT.

By C. P. Young.

## PART IV.

The best machinist to employ in the machine shop of an electric road, is a man who has served his time either in a locomotive, marine, or jobbing shop, and who has traveled around and gained experience from several other shops. Of course the first few weeks all motor parts will be new to him, but by a little instruction he will soon catch on, and when he has learned the various relations of parts it can be relied on that his work will be right and not botched. A simple swinging crane (which can be home made for a few dollars) should be at his lathe so that he can handle the armatures alone. To turn a commutator as it really ought to be turned is a very delicate operation. When finished it should be so round that when the lathe is speeded up, the finger resting on the commutator and the face of the tester turned away, it should feel as if the commutator was standing perfectly still. Waste should never be put on a commutator. I find cheese cloth gives splendid results. Men who handle armatures should be trained to imagine that an armature is as delicate as an egg shell, and that between its usefulness and failure is only the thickness of a tissue paper. An armature should never be laid on a bare floor but should always rest on something soft. The coverings around bales of waste do very nicely or what is better still a truck with padded top.

Now to the armatures and fields. I think I can safely say that no item has cost investors more than the burning out of armatures and fields. In the early roads the loss was simply fearful. I have seen a road with 14 cars and with 42 burnt out armatures on the floor at one time.

This was all wrong and due to imperfect insulation, careless winding and rough handling of car by ignorant motormen. No material or workmanship is too good for an armature. My method is the following: First, I turn down the core about  $\frac{1}{16}$  of an inch, so that I can get more insulation on than the factory generally uses. I glue asbestos all around the core; then a layer of pure mica equally thick; then several layers of mica cloth. Allow this to dry thoroughly. Each and every wire is then shellaced not only on top but every particle of wire is well covered.

I find that shellac at no less than three dollars per gallon gives the best results. I have tried several compounds but found them to corrode more or less. On the corners of the cores and for each layer of wire I use mica cloth cut to fit. When armature winding is finished take a trolley rope and wind very tight around the whole so as to make it as tight as possible, and then allow it to dry.

In winding it is best to have two or three armatures under construction at the same time so as to allow each layer to dry thoroughly before the second is put on. In connecting armatures and commutators I use flexible wire. I also fill up the space back of the commutator and in front of the armature with old canvas and tape, so

that the flexible wires rest on an insulated bed. I have had armatures made in this way run over 1,000 revolutions per minute, at full speed, from 18 to 20 hours per day, for over three years, and they are running yet.

In winding fields I follow the same method. I use no metallic spools but vulcabeston only, thoroughly shellac each layer and dry well; then cover with a layer of thick canvas well shellaced; then several layers of tape; finally put a rope around it very tight. I have several times had the lower fields almost covered with water and as yet no short circuit or burn out. In putting commutators on the armature shaft they should never be driven on by hammer or sledge, as every blow is liable to jar the segments, but they should be pressed on either by a hydraulic or screw press.

A very simple and effective screw press can be made in any shop in the following manner: Have two  $\frac{7}{8}$ -inch machinery steel bolts with large heads. The body of the bolt should be 6 inches longer than the armature shaft and threaded according to the length of the shaft.

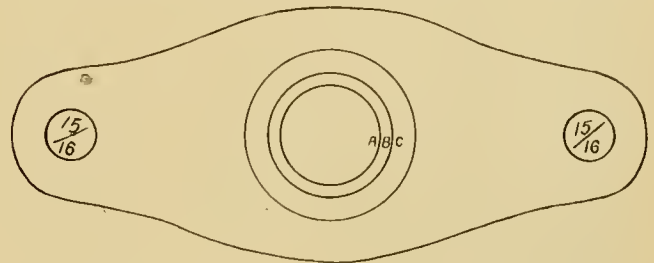

FIG. 1.

The nuts ought to be at least  $1\frac{1}{2}$  inches long. Two pieces of iron  $2\frac{1}{2}$  inches thick and shaped as in Figure 1 are next necessary. The distance between inner edge of the bolt holes is at least one inch more than the diameter of the armature. Have the back piece counter bored to fit the diameter of the pinion end of the shaft about  $\frac{3}{8}$ -inch deep. The front piece should be bored out at least one inch larger than the commutator sleeve bore and then bushed with a brass sleeve having a strong shoulder, said sleeve to be bored about  $\frac{1}{8}$  inch larger than the shaft. The shoulder of the brass sleeve should be slightly smaller than the bottom of the thread on the commutator sleeve, so that when pressure is applied on the clamp it will press only on the sleeve and not on the nut.

Commutator sleeves should never be counter bored but should fit the whole shaft throughout. The key should fit the full length of shaft and sleeve. To take a commutator off the shaft I use a sampson, the same as for pinions, with this difference; instead of end lugs a straight sampson is used, with flat holes right through, and having steel keys to fit the same, so as to press against the sleeve and to occupy as small a space as possible between back of commutator and front of armature.

In every electric railroad shop there should be a man who understands something about blacksmithing so as to be able to weld broken brake-rods, dash-boards and posts. The carpenter should be a man of versatile ability; able to cut glass; a good upholsterer; a fair pattern maker; besides being a good carpenter and car repairer. In the

front of the shop there should be a desk with a book nailed to the top of desk, where the slightest defects on cars, motors or trucks should be reported, including date, number of car, defect found, and name of motorman. This book should be inspected every hour, and when the damage has been fixed, should be marked O. K. by the foreman or man in charge of the department to which the repair belongs. The night crew should be so organized as to allow every car to be thoroughly cleaned and windows washed. Every motor and controller in all details from the trolley wheel down should be inspected and all defects remedied; hence, the man in charge of the night men should be a good machinist and electrician. He should have worked day time in the shop, so as to be familiar with the methods employed and be friendly with the day men, so as not to put the blame on the wrong shoulders when mistakes have been made. The shop should be handed over to the night men in perfect order with all tools in their proper places, and it should be found the same way in the morning. Cleanliness first, last and all the time. All shop men should be impressed with this great law "that every car should leave the shop cleaner than when it entered." It is a crime to send out cars full of grease spots and black dirt. We have no right to ruin passenger's clothes, yet, alas, this is frequently done. Every car that has been in for repairs should be thoroughly examined from top to bottom. Every nut, bolt, split-pin, wire, and in fact everything should be right, and the motors tested by trial before the car is handed over to the motorman. One of the most important points of all, is the brake on cars, where the chains wind around the staff. The third, fourth and fifth links wear the most and every link ought not only to be examined when the car is in for repair every night, but by the motormen themselves every day.

In hiring an armature winder it is best to get one who is also a machinist, so when work is slack in the winding department he can help the machinist. Men in the shop should be organized like a fire brigade so that each man knows what to do in case a car gets off the track or any other trouble occurs. There is sometimes a great tendency to jealousy, existing between the shop men. This can be easily averted. The men should all be like brothers to each other. The work should be made cheerful and not burdensome. The good will of all should be obtained, so that sometimes when work is being rushed, and perhaps only a few minutes are allowed for dinner, no complaints or kicks should be heard, but instead, this sentiment will prevail; "We will do anything for our superintendent, and we know it is all for the good of the road."

I may as well say something here in regard to the art of soldering. All electrical work requires soldering and every shop man thinks he understands it. This is not so. The first thing to learn in mastering this art is cleanliness. Clean acid, clean contact surfaces, clean solder, and above all a clean soldering iron well tinned. It is not sufficient to melt the solder, but the pieces that are to be soldered must be brought to the temperature of the melt-

ing point of the solder so as to well fill all the space with solder; when the work has been finished the soldering iron should be put in its place clean and well tinned, so as to be ready for use without any waste of time. A splendid non-corrosive soldering fluid can be found in the following formula:

Saturated Solution of Zinc 5 parts.  
Alcohol 4 parts.  
Glycerine 1 part.

---

#### ARTHUR W. FIELD.

There is no branch of the street railway business that Vice-president A. W. Field, of the Peckham Motor Truck & Wheel Company, has not touched. His motto has been, "Know something of everything and everything about something." The latter "something" is the street railway truck.

Arthur W. Field was born at Providence, R. I., in 1861 and received his education in the city schools and at the Scholfield Commercial College. In 1879 he entered the office of the Union Railroad Company of Providence and learned the office routine in all details. In 1884 when the company opened up its large repair shops, Mr. Field took up mechanical matters in the same thorough fashion and spent five years in this thorough schooling ending as assistant master mechanic.

Next as general agent of the Frank H. Andrews Car Wheel Company, of New York City, he spent 18 months on the road. Resigning from this position Mr. Field became agent of the railway department of the original Thomson-Houston Company, but at this time his health failed, and after unavailing medicine Mr. Field took to the fir and pine woods of Maine where he roughed it for eight months, returning fully recovered.

On his return to civilization he accepted the position of general sales agent for the American Steel Car Wheel Company of Boston, remaining until its re-incorporation. Then, as Wells & Field, the subject of our sketch, found much experience and some money as contractor and builder of street railways. Finally, on the dissolution of this business, Mr. Field became agent for the Peckham Motor Truck & Wheel Company, and in 1893 was unanimously elected vice-president of this substantial and widely known institution, for which position his wide acquaintance, thorough knowledge of detail and long experience particularly fit him. Mr. Field's headquarters are at 53 State street, Boston, where the visiting street railway man will be hospitably received.

---

THE Buenos Ayres, S. A., tramways, have increased fares twenty-five per cent.

THE NEW POWER HOUSES OF THE WEST  
CHICAGO STREET RAILROAD  
COMPANY.

The Two Palaces of Mechanic Art Built by the Pennsylvania  
Iron Works—The Special Devices and Standard  
Machinery—The Largest Tunnel  
in the World.

To give to the great southwestern portion of the city of Chicago rapid transit, the West Chicago Street Railroad Company has built two fine power houses, laid several miles of expensive cable conduit and has driven to completion in the face of difficulties, the largest tunnel of single span in the world.

The two power houses known respectively as the Blue Island power station and the Van Buren street power house, are situated, the one at the corner of Blue Island

The boiler room is well arranged, with a view to economy and convenience, the batteries being placed on a level with the driving machinery. They are eight in number, of the tubular type, made by John Mohr & Sons, Chicago, for the Pennsylvania Iron Works. Each boiler is of 225-horse-power making the total capacity of the plant 1,800 horse-power at 150 pounds steam pressure. The furnaces are now fired with oil. They are equipped, however, with the Gulickson grate, so that coal may be used should necessity arise.

Automatic pressure regulating valves are provided for each boiler and the piping is so arranged that the boilers can be used together or separately. The main header is 60 feet long and 30 inches in diameter.

Two Berryman heaters of 1,000-horse-power each and Snow pumps of the duplex pattern are used to supply feed water to all boilers. There are also, by way of reserve, two Monitor injectors, which can supply the



WEST APPROACH OF TUNNEL ON JANUARY 15, 1894.



WEST APPROACH OF TUNNEL SIXTY DAYS LATER.

avenue and Twelfth street, and the other at the corner of Jefferson and Van Buren streets.

The Blue Island station, now operative, drives 60,600 feet of cable, operating the two systems of cars known as the Blue Island avenue and the South Halsted street lines.

To the exterior view, the power house is a handsome structure of pressed brick, trimmed with Bedford stone, fronting 120 feet on Twelfth street and 183 feet on Blue Island avenue. The power house proper, that portion used in the power production, is 116 by 100 feet. The rest of the building, at the street intersection, is carried to the height of six stories and sublet as offices.

The stack is 150 feet high, carrying the gases well above the offices. An abundance of light and air is provided the power plant by means of a system of ventilators and skylights. The roof is of double iron, the peak of which is 60 feet above the floor level.

The entire exterior is a great improvement on the surrounding property and an ornament to that section of the city.

entire battery when necessary. It will be noticed that every precaution for continuity of power is provided.

The engines are of the E. P. Allis type, two in number, of 1,000-horse-power each. The cylinders measure 40 by 72 inches, and the fly wheels weigh 100,000 pounds each. They make fifty revolutions per minute and are 24 feet in diameter. These wheels are of very handsome design, built up in eight sections and magnificently proportioned.

The line shaft is 18 inches in diameter, running the entire length of the engine room and coupled to both engines at right angles by means of steel cross-key plate couplings. Four sets of drums are driven from the shaft, three of which are 13 feet 4 inches in diameter, the fourth one being 16 feet in diameter. The former weigh 16 tons each, and the latter tips the scales at 20 tons. They are all equipped with the famous Walker differential rim. One hundred and fifteen tons of steel cut gears are used to transmit the power from the line to the drum shaft. The bed plates are of hollow rectangular

form. The cable drums are provided with 1,000-horse-power Walker friction clutches, by means of which they can be stopped or started at the will of the operator. Three sets of drums are in active service, the fourth being kept in reserve. With an arrangement of vault

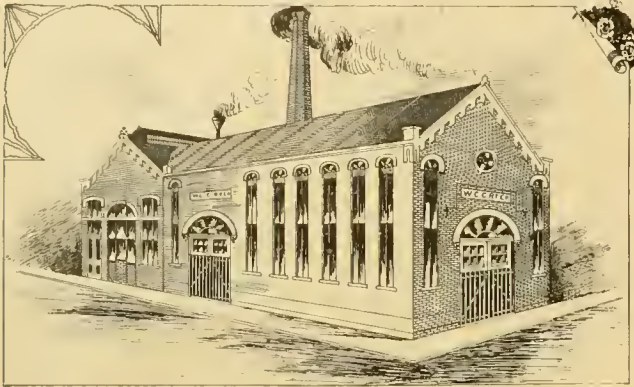

VAN BUREN STREET POWER HOUSE.

sheaves any cable can be driven from the fourth set of drums in case of necessity.

The tension carriages are of the usual Root pattern, as used in San Francisco, St. Louis and Chicago. The

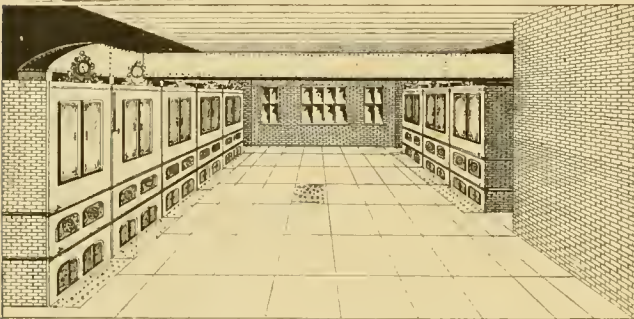

BOILER PLANT, VAN BUREN STREET STATION.

tension runs are underneath the boilers and 84 feet long. Two cable winding engines are placed between the tension runs for taking in the old cables. There is also in the basement a steam shears for cutting up the cable for shipment.

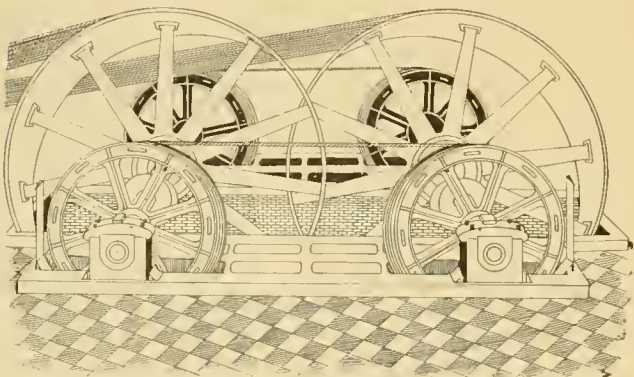

WINDING MACHINERY, VAN BUREN STREET STATION.

The entire building is lighted from its own plant of the Siemens-Halske description, running twenty arc lights. The sheave pits are also thus illuminated.

During the erection of this power house, almost end less difficulty was experienced in finding bottom for the foundation, as the chosen site had once been a marsh. At a distance of 40 feet below the level, however, a hard stratum was found. This made it necessary to excavate 100 by 52 by 40 feet, which was filled with concrete, upon which foundation and walls were erected.

Without doubt, the West Chicago Street Railroad Company has performed as difficult engineering feats in

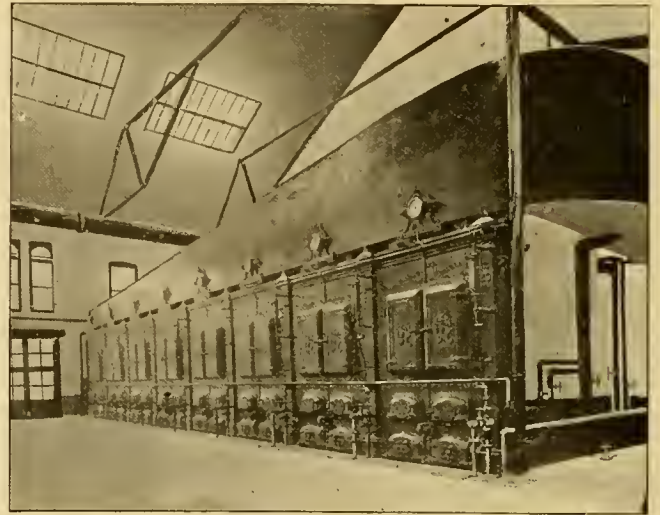

BATTERY OF BOILERS, BLUE ISLAND AVENUE STATION.

combating sinking clay and sand, as any other power plant builder ever experienced in blasting rock or bridging chasms.

#### THE VAN BUREN STREET POWER STATION,

fronts 175 feet on Jefferson street and 50 feet on Van Buren. From it is driven the rope for the loop, which is 13,000 feet long. This station is also of pressed brick construction and trimmed with Bedford granite. It is almost Ecclesiastical in appearance and the architect has shown great taste in the design. The machinery of this station is bedded on brick. The stack is 150 feet high and the fuel used is oil.

The distinguishing feature of the Van Buren street plant is the rope drive, which is one of the longest in the country, being 75 feet from center to center. The engines are from the Allis works, measuring 30 by 60 inches and two in number. They are of 1,300-horse-power each and have 20-foot fly wheels of 100,000 pounds avoirdupois. The boiler, water heater, piping arrangement and attachments of the boiler room and engine rooms are exact counter-parts of the Blue Island plant.

The plant is so arranged that there is a 32-foot rope wheel, the shaft of which connects with the drum shafts driving both drums. The rope used is of the celebrated Brigham cotton, three inches in diameter. The cable drums are 13 feet 4 inches in diameter and are in two sets, one always in reserve. The tension carriage is of the Root pattern and runs 100 feet. A reel engine is also provided for bringing in the cable.



The Pennsylvania Iron Works, which was the builder of these two magnificent power houses, deserves the greatest credit for the successful consummation of a most difficult task. To any one in the least cognizant of the latter day power house building, these two stations need no word of commendation, but even the lay brother must acknowledge the beauty, grace and strength of the

The signal reads on the ribbon thus:

10 10 10 I I I = 33

The Blue Island and the Van Buren street power houses are also connected by similar signals. Above the signals are the steam pressure gauge and low water alarm.

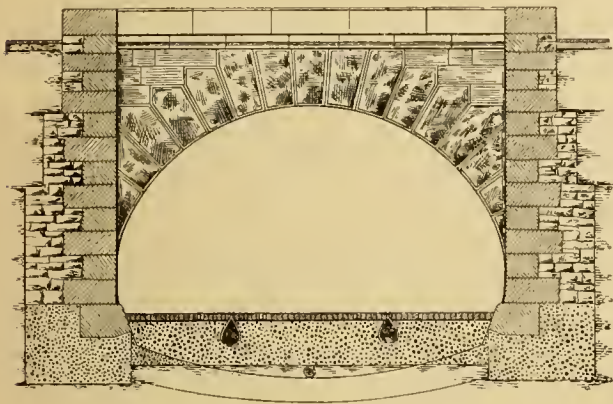

ELEVATION OF TUNNEL PORTAL.

pulsating, almost animated, mass of machinery which fills the tasteful buildings. William Elkins, Jr., the president of the Pennsylvania Company, B. W. Grist, C. E., and Engineer S. Potis, of the West Chicago Street Railroad have acquired more than passing distinction in the success of this great work.

THE SIGNALING DEVICE.

The signaling device shown in our engraving is placed in the Blue Island station and connects each block of the Halsted street and the Blue Island avenue lines with the power house. At a convenient point in each block, and



ELECTRIC SIGNALING DEVICE.

THE VAN BUREN STREET TUNNEL.

Just between Van Buren and Jackson streets and running from Franklin street on the east to Clinton street on the west side of the river is the greatest single span tunnel in the world. It is built on private property, at the expense of \$1,600,000 and in the face of almost insuperable difficulties. It was begun early in 1891 and has now triumphed over mud, madness and misery of law suits. The tunnel is 1,514 feet from entrance to entrance and

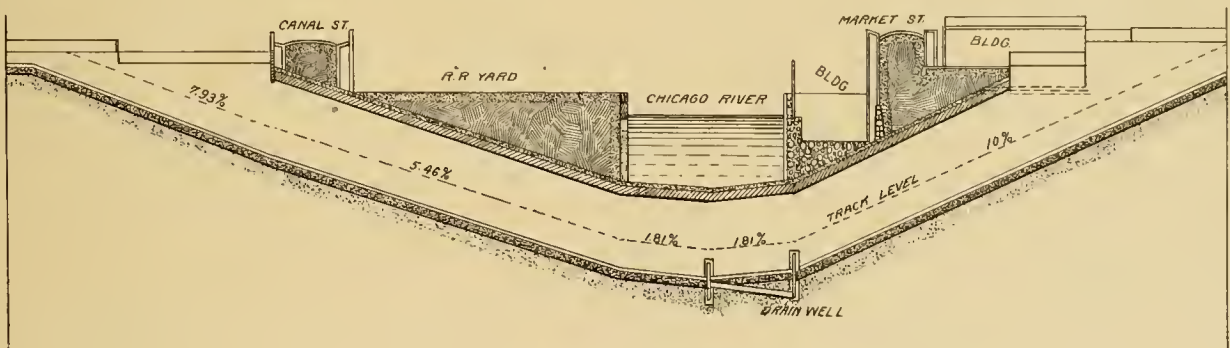

LONGITUDINAL SECTION OF TUNNEL.

at two places in a long block, is placed a call box, to which every gripman has a key. In event of trouble, strand or blockade, an alarm is turned in. One turn rings the gong once and calls for the stopping of the cable, three rings summon the wrecking wagon and two rings means "start the rope." At the same time a relay telegraph device prints on a paper ribbon the number of the block. There are 61 boxes on the line, 31 on Blue Island avenue and 30 on Halsted street.

consists of one elliptical span of 30 feet. The length of the tunnel proper, from portal to portal is 920 feet. The east approach is 278 feet and the west approach is 316 feet. The gradients run as shown in the diagram.

During the progress of construction, the buildings too valuable to be destroyed, but whose foundations had to be undermined, were elevated on hundreds of hydraulic jacks each capable of lifting 30 tons. In no case was a wheel disturbed of the manufacturing interests in the



INTERIOR OF TUNNEL DURING CONSTRUCTION, SHOWING METHOD OF BRACING.

building nor an elevator stopped. The network of railroad tracks was passed in safety as well as the docks and the river. The shifting clay which has marvellous power of torsion was successfully restrained until the brick was laid. Three million bricks were used in the work, 6,000 barrels of hydraulic and 15,000 barrels of Portland cement. The tunnel is of brick in seven rings, aggregating 32 inches thick, and the portals of Bedford stone. The two tracks for the cable are spaced about 15 feet from center to center, thus giving safe clearance along the walls and between cars.

The sumps and drains for seepage and storm water are amply sufficient and the tunnel will be dry but interesting even in wet weather. The tunnel is 15 feet 9 inches high at the center. The river section is concreted, covered with asphalt mortar and laid with flagging, so that by no mischance can the tunnel be broken into by a vessel striking the river bottom. Samuel G. Artingstall was chief engineer and C. V. Weston was superintending engineer.

The appliances for the safety of passengers, include an unique feature, namely

#### THE RACK RAILWAY.

When the new Van Buren street tunnel of the West Chicago Street Railway was proposed, it was also determined to introduce absolute safety devices on the grades. To this end, a rack railway plan has been adopted. On

each side of the slot rail half way between the slot and track rails is set a rack rail which will engage with a pinion on a separate axle of the grip car. The rack will extend entirely through the tunnel except the 200 foot level stretch at the center.

The rack, a section of which is illustrated, is in 3-foot 11½-inch sections, weighing 256 pounds each. It is 6 inches wide, with teeth 2¼ inches high and of 3 inches

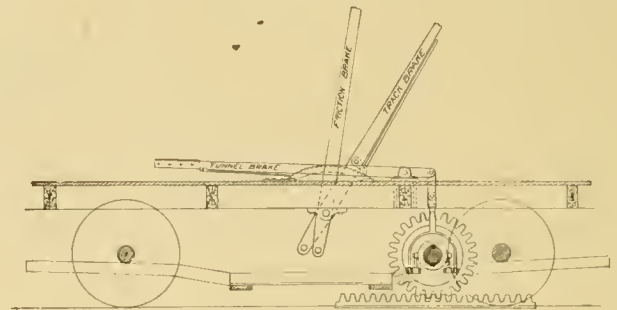

ELEVATION OF RACK DEVICE.

pitch. A wooden liner surfaces the iron and wooden cushions between the rack and yoke taking off the shearing strain from the bolts which hold it to the yoke. The entrance to the rack is provided with a differential rack section supported at the entering end by a coiled spring, which allows the pinion to mesh with the rack, no matter at what speed the car may go. The pinion of each grip car will be carried high enough to clear any obstruction

on the street, and being on a separate axle, will be set to engage with the rack on entrance to the tunnel. A friction brake mounted on the pinion axle is to be powerful enough to stop the car in any distance desired. The pinions weigh 150 pounds each, or an equal to the weight of two passengers. The conclusion of the matter and tests will be watched with interest.

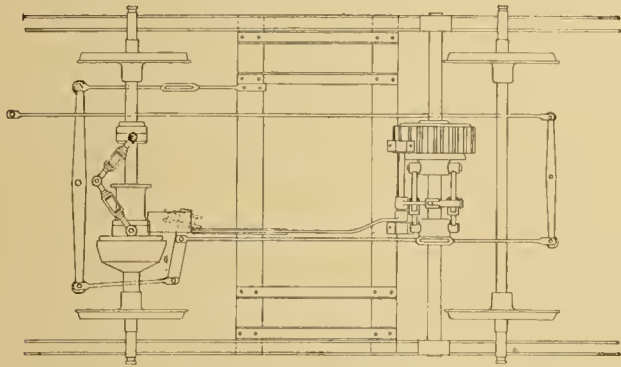

PLAN OF RACK DEVICE.

The device is the invention of S. Potis, the company's chief engineer, and is working very satisfactorily indeed.

The tunnel in completion presents an elegant appearance. It is lighted thoroughly by the Nutting arc lamp, made by Bartholemew, Stow & Co., Chicago. The lamps are 50 in number, of 2,000 candle power each and are run at 110 volts from a Waddell-Entz machine. The lighting plant is owned by the West Chicago Company.

On April 21, the first train formally opened the great

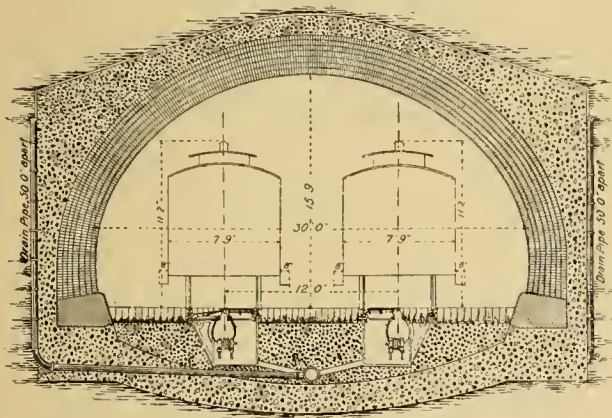

ORDINARY SECTION OF TUNNEL.

undertaking and six decorated cars carried a distinguished crowd of street railway men of the city, contractors and engineers of the undertaking and city officials, around the loop, through the tunnel and back to the Van Buren street power house where an elegant collation awaited the guests. Mr. Yerkes was master of ceremonies and in his happiest manner bade the guests welcome and called upon several prominent west side residents, who responded in words of praise for the man and the undertaking.

Thus the end crowned the work.

THE Sandusky, Milan & Huron Street Railway Company began hauling American Express in a special car, April 1.

PETROLEUM BRICK FUEL.

The method of manufacturing petroleum bricks for fuel, as followed by Maestracci of Havre, France, is attracting considerable attention abroad.

The receipt is this: Mix one litre (1.05 quarts) of petroleum, 150 grams (5.29 ounces) of triturated soap, 10 per cent of resin, and 333 grams (11.75 ounces) of caustic soda. Heat and stir until solidification begins, say 40 minutes. If the mixture tends to boil over, pour in a few drops of caustic soda. Pour the semifluid mass into moulds, and place in a hot or drying room for 10 or 15 minutes. Then remove and cool. M. Maestracci recommends the addition of 20 per cent of sawdust and 20 per cent of clay or sand to the original mixture. Trials of these bricks are said to have developed three times as much heat as ordinary coal brick and leave no ashes. With some change in furnaces, it is expected that the bricks will develop four times the heating power of coal, and specially adapted to street car heating.

THE Oakland, California, Consolidated Electric Railway Company has concluded to do away entirely with the pass system, and no more will be granted.

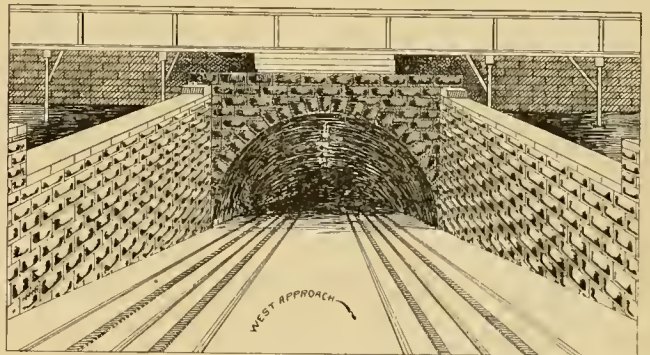

THE Remscheid (Germany) tramways, finished in 1893, have been in successful commission since. It is an overhead, single track, side pole system.

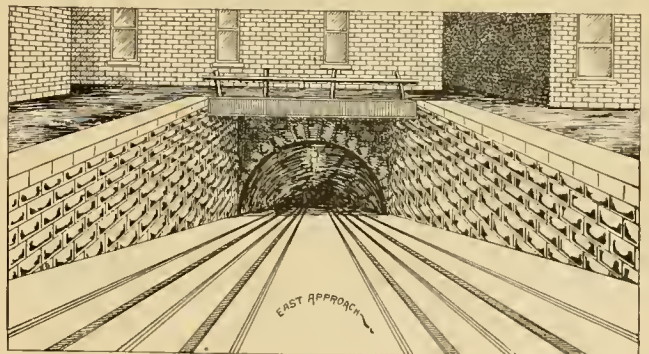

DON ALBERTO PALACIO, an engineer, has been granted a concession at San Sebastian, Spain, for operating an electric tramway. Traction, in Spain has made little progress, and it is hoped that the San Sebastian road may be the forerunner of many others.

## NEW YORK NEWSBOYS.



ON April 23, newsboys were interdicted from riding on the principal street car lines in New York City. The introduction of rapid transit has made the rule imperative. This cause was added to by the complaints of patrons whose feet and clothes suffered from the youngsters' rush through the cars. The

Metropolitan began the action, which is general on all its lines in New Jersey, Philadelphia and elsewhere.

## THE ACME CAR JACK.

The numerous occasions, both in the barn or shop and on the road, for lifting a car body, or car and truck, require more than the brute force and awkwardness of the few employes and numerous willing bystanders. In fact, a reliable, portable and competent car jack has become an absolute necessity in this time of heavy cars and trucks. A car jack will pay for itself on the first occasion of its use.

The Lewis & Fowler Manufacturing Company, of Brooklyn, N. Y., keeping up with the demand for a good jack, has put upon the market the "Acme," represented in our engraving. The Acme Jack is sufficiently powerful to lift the heaviest car, yet is portable and easily handled. Two men can raise a car with it quickly and safely, and hold it in position for any length of time. Its con-

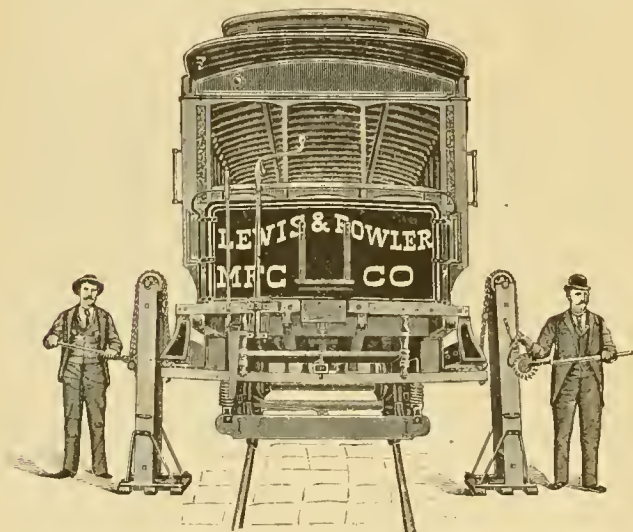
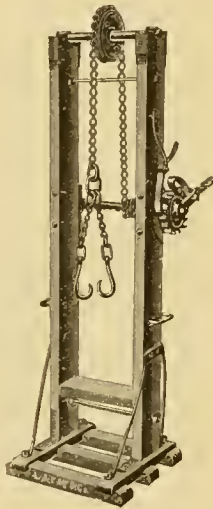

struction is simple, and it is strongly built so that both for shop work and line emergencies, it is reliable and efficient.

## MAINTENANCE OF ROLLING STOCK.

## IV.

The Wilmington, N. C., Street Railway owns the following rolling stock: Six 8-seat open cars, with two 15-horse-power S. R. G. motors. Two 16-foot closed cars with a like equipment. Four 16-foot closed cars with two 15-horse-power Sprague number 6 motors each. In the winter season six, and in the summer twelve cars, are in regular use. The Thomson-Houston part of the equipment is two years old. The age of the Sprague motors is so great as to have become an unknown quantity. The barn force consists of one inspector, an apprentice, a general workman who cleans cars, oils switches and helps wherever needed, and a night watchman, who looks over and cleans cars and motors. Motormen report every night any faults discovered. If the night watchman cannot fix them the car is kept in. Cars are brought in when general repairs are needed, or oftener if work is slack in the sheds. Motormen make their daily reports on the back of conductor's daily report, and also make a note of repairs needed on a car, for the use of the night man. Armature and field winding, light blacksmithing and painting, and varnishing are done in the barns.

The cost of repair parts for the electrical apparatus on the cars is .151 cents per car mile. The cost of repair parts for cars exclusive of electrical equipment is .344 cents per car mile. The cost per car mile of repair and inspection labor, including the man who does the cleaning and general work, is .668 cents per car mile.

The total cost of car maintenance is therefore 1.163 per mile. The company has never lost a field coil or armature section, wound in its shop. There is not enough work to support a machinist, but the company contemplates employing one, and taking in enough outside work to fill up his time. John H. Barnard, vice-president and general manager, says of the system: "We can recommend to small roads the system employed on this road of accomplishing our repairs and instructing our men at one and the same time. All candidates for the position of motormen or conductor, must serve a period of probation and apprenticeship in our car shed. When a man is accepted, he becomes the junior of usually six men, and works assisting the inspector or foreman (whichever he might be termed) in all work about the shed. They are entitled in order of seniority to filling the place of any conductor or motorman, who may be sick or off for the day, and to vacancies, as they occur, among the regular men by resignation or discharge. The only pay they get during this period is the time lost by regular men or extra runs, and 12½c per hour when extra cars or trailers are needed. It usually happens that the senior one makes quite as much as a regular man, as lost time is charged against regular men at a higher rate than their pay, and this goes to the extra man or men doing the work.

The instruction they gain in assisting in repairs gives them a very fair understanding of the machinery they

are to handle as motormen, and greatly lessens the mismanagement of the equipment. They are also quick to notice troubles, which if not corrected at once would lead to more serious trouble. While forbidden to attempt the correction of troubles, they do not understand they have often displayed much ingenuity in repairing slight troubles which would have stopped their car. Inefficient men are quickly weeded out in the shed. Men who have secured a regular run appreciate it more for the apprenticeship it has cost them. We get a great deal of repair work for nothing; have always a half dozen extra men to call on in an emergency; better class of motormen; and when needed any conductor can serve as motorman. Bright men are taught armature winding, etc., and are given extra pay when so employed. Four men brought up in this way have become foremen on other roads; one a superintendent."

THE UNITED ELECTRIC RAILWAY, NASHVILLE,

has 66 double motor cars consisting of thirty-eight, F-30' twenty Sprague number 6, and eight Westinghouse double reduction number 1. Forty-eight are in daily use. To keep them in operation a force of fourteen men is employed. There are two foremen,—one for each barn,—four day men, four night inspectors, and eight night car cleaners. The motors, being inspected every night, are overhauled only when necessary. A system of repair blanks is used. All repair work is done in the shop. The pay roll of this department is \$28.50 per day. The cost per car mile of cleaning repairs, and labor on bodies, trucks and motors is 2.96.

E. G. Connette, general manager, contributes the following valuable suggestions: "Our cars are all equipped with an obsolete type of motor which makes the expense of maintenance very high. Furthermore, we are limited in equipment, so that the cars we have are required to do harder service than they should, which makes the expense higher than it would be, if we had an ample equipment, enabling us to keep the cars in better condition. The manner of cleaning, oiling, inspecting and repairing cars and motors, should be governed to a great extent by the manner in which the cars run, and the number of extra cars to be used for substitutes. Where the equipment is limited to only enough cars to fill up the lines, with a sufficient number of extra cars to substitute for disabled ones, the work of cleaning, oiling and inspecting should be done at night. When a car comes in at night, it should be cleaned and the motors wiped off and oiled; the motors should then be thoroughly inspected to see if all connections are intact, brush holders tight, brushes making good contact. If necessary put in new brushes, inspect the gears and pinions; examine the light circuit, and test it to see if the circuit is all right; examine the trolley and oil the wheel; but the most important part of the inspection is the brakes; they should be very carefully inspected every night, and put in good condition and tested before the car is allowed to go out. We employ one man whose only duty is to inspect and work on the brakes at night. Where a road has a sufficient number

of extra cars and it is convenient, it would probably be better to do this work in daylight. If the motors are properly inspected and receive proper attention at night, the cars should run all day without coming into the shed for repairs or trouble of any character. Overhauling and repairing, as far as possible, should be done in daylight by mechanics employed for that purpose, in order that the work may be done properly."

THE TRUSS RAIL JOINT.

This is one of the most simple and at the same time most successful attempts to make a rail joint that will keep the gray hairs out of the young railway manager's head. A base plate is used and the bolts of the truss serve to hold the rail ends firmly to the base plate. The

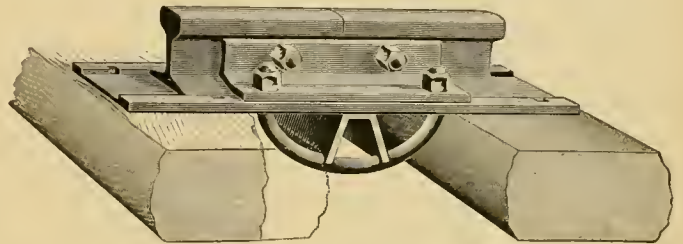

angle plates have nothing to do with supporting the rail ends and act only to keep the heads in line. As long as the truss bolts hold firmly, the rail ends must stay in surface. The joint is well adapted to street railway service and is specially valuable in pulling joints back to line after they have become low. It has been successfully used on large steam roads for four years and is made by the Truss Rail Joint Company, of 1111 Monadnock building, Chicago.

ONE OF MANY.

The editor of the De Kalb (Ill.) Review, is a rose-colored optimist. He wants an electric railway in De Kalb, whether it will pay or not. After pleading for the usefulness of street cars, ye editor saith:

"There is nothing like looking on the bright side of things. That's the side your humble servant looked on when he tried to publish a daily paper in DeKalb with all out-go and no in-come as the base of operations. The fact that the daily didn't pay was a mere trifle. It was a source of pleasure for the people, and the right thing for the publisher to do was to publish it as long as bright side held out. We like to encourage worthy enterprises of all descriptions. Street cars might not pay in a strict sense of the term, but they would be awful handy to ride on, and the name of having them would outweigh all other considerations. Welcome, street cars to our order."

Won't somebody, please, buy the editor an electric railway.

THE Budapest Tramways carried 12,500,000 passengers in 1893, 11,000,000 in 1892 and 8,500,000 in 1891.

PERFORMANCE OF THE LIVERPOOL OVERHEAD RAILWAY.

In our issue of March, 1893, we gave a description of the plant installed for working the above road. We are now able to give figures as to its performance, and it is gratifying to note that they are very favorable to the use of electricity. A very full account of the line and its working was recently given before the Institution of Civil Engineers, by J. H. Greathead, Francis Fox, and Thomas Parker. It is from these papers that the following figures are taken.

The road was operated during 1893 by the Electric Construction Company, of Wolverhampton, which company built the road and agreed to operate it for two years, at a cost of eight cents per train mile. The trains consist of two cars, and seat 114 persons. The average actual working expenses per train mile for the three months, from July to September, are as follows:

Time standing at stations, 4 minutes, 40 seconds.  
 Average speed while running, 16.1 miles per hour.  
 Average speed, including stops, 13 miles per hour.  
 Electrical horse-power, while running, 59.1  
 Electrical horse-power, including stops, 46.

The curves of the station output show the influence the number of trains on the line has on the current variation. When seven trains are on the road, the average output is 430 amperes, and the maximum 860, or 123 amperes per train. With twelve trains in use, the maximum current is 1,200 amperes, or about 1½ times the average current. The coal per train mile varies from twenty-five to seventeen pounds, according to the number of trains in service. The latter figure was made when the traffic was lightest.

The trains consist of two double truck cars, having one gearless motor each. These motors are controlled with a series-parallel controller. An inspection of the curves reproduced here shows that the most current is required, not at starting, but when the motors are thrown

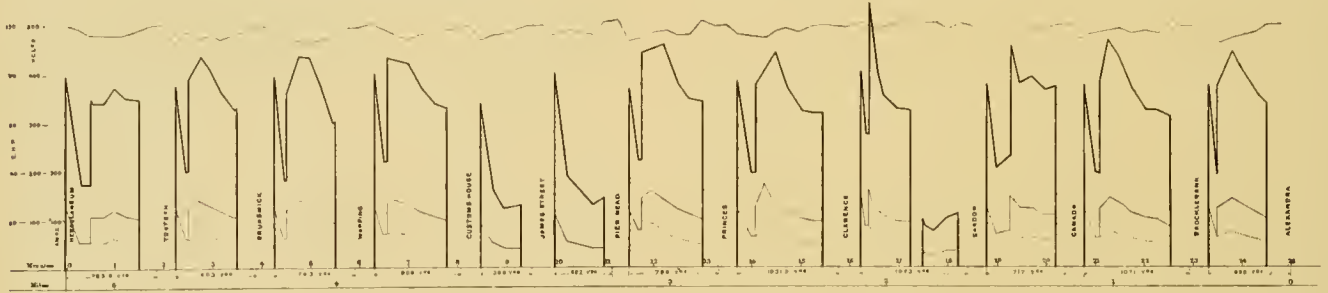

MOTOR CURRENT CURVES.

Supervision.....	\$.32 cents
Generating station wages.....	1.224 "
Drivers' wages.....	2.118 "
Coal.....	1.690 "
Oil, waste and grease.....	.272 "
Water.....	.024 "
Stores and sundries.....	.178 "
Cleaning and repairs to carriages, switches, etc.....	1.692 "
	8.030 cents

This includes the cost of current for lighting stations, working signals, and driving tools in the repair shop. Owing to the colliers' strike, the cost of coal is considerably higher than it would be under normal conditions. During July the cost was only 1.178 cents per train mile, which rose to 1.23 cents in September. Coal rose from six shillings to seventeen and a half per ton. The showing during 1893 was so good that the railway company decided to relieve the construction company of its two years' contract and take over the road. This has been done, and the railway is saving money by it. During the three months previously mentioned, the watt hours per train mile were 2,800. The coal burned was 17.44 pounds per train mile. The coal used was slack, having 70.08 per cent of fixed carbon, 16.47 per cent of volatile hydrocarbon, and 8.51 per cent of ash.

A test made with a fully loaded train, weighing in all thirty-nine tons, gave the following results:

Distance run, 5.125 miles.  
 Number of stops, 12.  
 Time on journey, 23 minutes, 47 seconds.

from series to parallel. This has been also observed on certain forms of series-parallel controllers in use in this country.

The authors compare the relative economy of steam and electricity, and as their estimates are based on actual facts, they are of great value. Comparison is made with the Ninth Avenue Elevated, of New York, the two roads being nearly the same length. The cost of electrical equipment on the Liverpool Overhead is about 5 per cent of that which was estimated for the Ninth Avenue line, after the unfortunate electric locomotive trials on the latter road some years ago. With a train mileage equal to that of the Ninth Avenue road, the operating expenses at Liverpool would be six cents a train mile. The actual average consumption of coal at Liverpool is 16 pounds a train mile, for trains weighing 38 tons, seating 114 passengers, and averaging 12 miles an hour, as against 54 pounds, in New York, for trains weighing, with locomotive, 92 tons, and making the same time and same number of stops. The coal used at Liverpool is bituminous slack, and that at New York anthracite. Electric traction is really the cheapest, allowing for difference in conditions, and when the electric line mileage increases, the comparison becomes still more favorable to electricity.

The construction and operation of the Liverpool road has been under the direction of Thomas Parker, of the Electric Construction Company, and he certainly has cause for satisfaction in its unqualified success.

THE HOT AIR SYSTEM IN THE CALUMET BARN.

The main barn of the Calumet electric road of this city is fitted with a system of hot air piping that may prove useful to a great many roads in northern cities. The rear of the barn is of brick and is used as a repair shop. This part is heated by exhaust steam, from the power house, 150 feet distant, in the ordinary manner. The main or front part of the barn is used for shelter and storage principally. It is a corrugated iron structure, and no attempt is made to heat it as it would be almost an impossibility. However, it is extremely convenient to be able to thaw off parts that come in covered with ice and snow, without being obliged to take the car into the repair shop. To do this the following inexpensive

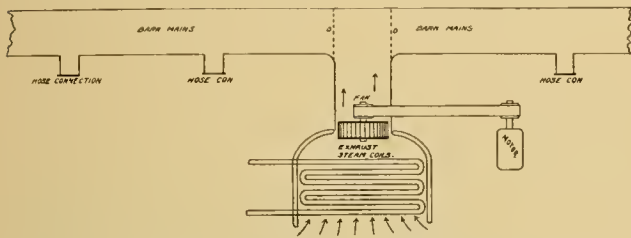

HOT BLAST SYSTEM, CALUMET BARN.

system was installed. Referring to the engraving, air is drawn through a bank of steam coils by a fan blower, driven by an electric motor. From the fan it is forced into a main pipe of galvanized sheet iron, running the length of the barn and carried on the roof trusses. These mains are about two feet in diameter, and have dampers, D D, to cut off the air from parts not being used. When hot air is wanted under a car a large hose is attached to one of the outlets made for the purpose, and which are located every few feet along the main. These outlets are covered by a simple sheet iron lid when not in use. The hose being attached and the fan started, hot air can be turned onto any part of a car or truck and in a few minutes it is clean and dry.

Although in this barn such an arrangement is specially needed, because the barn is not heated, it may prove a very valuable method in barns that are heated, because the thawing off of ice and snow is so much more rapid. Besides this, there is the drying effect of the stream of hot air which is worth a great deal in handling motors, especially the old styles. A stream of hot air will dry off a motor as nothing else can, as it penetrates into the cracks and corners. The most expensive part of the outfit is the motor, but on old roads, that most need this apparatus, a good enough motor for this service can generally be found in the scrap heap.

A PARKERSBURG, Va., maniac, after attempting a carbolic acid suicide, took possession of a street car and forbade any passenger to leave at the peril of his life. Finally the police were called in and the fellow secured, after compelling the conductor and driver to make two round trips.

TIE PLATES AND TRACK REPAIRS.

At the Association of Railroad Superintendents held at Buffalo, April 19, Benjamin Reece read a paper on the "Value of Tie Plates in Track Repairs." The chief value of tie plates, he says, is in the ease of track maintenance. Too much importance is sometimes attached to the area of the plate. A large plate must be a heavy plate to stand the strain, and a heavy plate is undesirable both in first cost and wear on rails. One of the most important offices of the tie plate is to prevent canting of the rail outward. When rails so canted are straightened up there is a great increase in the power necessary to move trains. When tie plates are used the rails are kept straight and the wheels and rails wear normally. Deterioration of track is due to the yielding and abrasion of parts, and the principal office of tie plates is to prevent this.

THE ELECTRICAL STUDENT'S A B C.

- A is the Amp. that went into the Arc.
- B is the Brush, sometimes seen with a spark.
- C is the Copper, most handy for mains.
- D is the Dynamo, driven without reins.
- E is the Science we study and pass in.
- F is the Field, with more iron than grass in.
- G is the Galvo., which "shorts" can foretell.
- H Hysteresis, heats iron like — (anything).
- I is Induction, much blessed and cursed, too.
- J is the Joule, set in carbon and cu.
- K is the Kathode, who lives in a bath.
- L is the Line, cut by wires in its path.
- M is the Motor, which torques as it works.
- N Non-conductor, which carrying shirks.
- O is the Ohm, found in wire as in brick.
- P is the Pole, which to iron wood stick.
- Q the Quickbreak on a high-voltage circ.
- R the Rheostat, which 'eats when at work.
- S is the Switch, like the ones used with trams.
- T is the Telephone; earns many bad — (words).
- U is the Unit, at fourpence a blessing.
- V is the Volt, who is always most pressing.
- W the Watt; E. C., when you know it.
- X the Xpense. House installers should blow it.
- Y is the Yoke, which in magnets is grey.

And the  
Z inc has connection with bells every day.  
J. H. C. B., in London Electrical Engineer.

CHEAP EXCURSIONS TO THE WEST.

An exceptionally favorable opportunity for visiting the richest and most productive sections of the west and northwest will be afforded by the Home-Seekers' low-rate excursions which have been arranged by the North-Western Line. Tickets for these excursions will be sold on May 8th and 29th to points in northwestern Iowa, western Minnesota, North Dakota, South Dakota, Manitoba, Nebraska, Colorado, Wyoming, Utah, Montana and Idaho, and will be good for return passage within thirty days from date of sale. Stop-over privileges will be allowed on going trip in territory to which the tickets are sold. For further information, call on or address Ticket Agents of connecting lines. Circulars giving rates and detailed information will be mailed, free, upon application to W. A. Thrall, General Passenger and Ticket Agent, [Chicago & Northwestern Railway, Chicago.

## THE BRISTOL, ENGLAND, TRAMWAYS.

In ye moste ancient and honorable citie of Bristol, England, ye folke travell by tramcar in ye most approved style. Hence this story.

Bristol was not built up in a day, and the interesting old place, 108 miles west of London, on the sea coast, has a most valuable collection of mediæval architecture, supplemented by modern houses and villas and surrounded by historic villages and hamlets.

To no other one interest do the people of Bristol owe more comfort and convenience than to the Bristol Tramways & Carriage Company, the lines of which radiate from the town center to all the main points of interest or industry. The route map is reproduced on this page. A copy of the map is placed in each car, and the management says it considerably increases traffic. Beneath the map is a list of fares which range from one to two pence, (two to

hours. Some of the aldermen are already awakened to the necessity of rapid transit and an effort to educate the public up to modernism is being made.

The plan of the proposed trolley line is that followed in all particulars by the Staffordshire system, as introduced by General Manager A. Dickinson.

As it is, the public has a kindly feeling toward the tramway and particularly for the employes. One manifestation of this spirit is the annual dinner, which is given by the *public*, (think of it!) as represented by a committee of which a clergyman is the chairman, to the drivers, conductors and other employes. At this dinner the management shows its appreciation by attendance. At the last dinner, held March 22, the substantial menu and hearty toasts were divided by music furnished by tramway talent. Among the latter, the competent and progressive manager of the traffic department, C. Challenger, was called upon for several violin solos, besides acting as

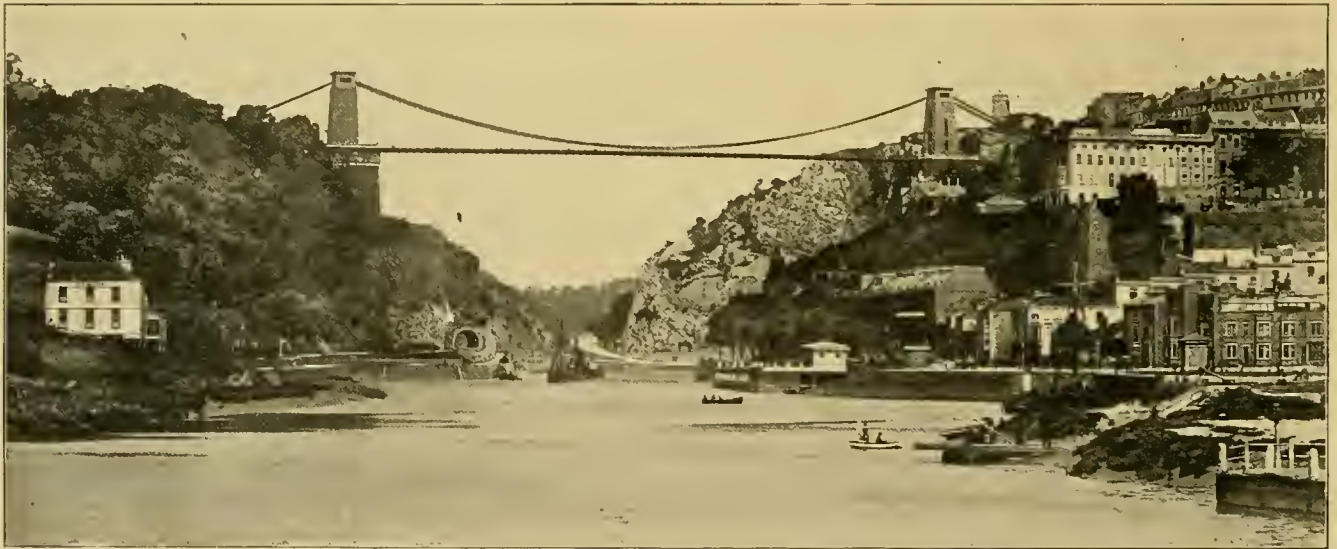

CLIFTON SUSPENSION BRIDGE, BRISTOL, ENG.

four cents) according to the distance. The law relating to payment of tram fares is also appended. At various places in the down town districts the map is reproduced with a black background, on a board five feet square, for the benefit of the traveler about to be.

Traffic on the lines is very good, as tram riding goes in Great Britain, with a noticeable increase year by year.

On Easter Sunday, 1893, the lines carried 60,139 passengers, in 1894, the same occasion brought out 73,828 passengers. Thirteen million people are carried annually on the system and a dividend of six per cent is paid.

The system is, of course operated by horses, and comprehends 13 miles of street, double tracked in the populous districts and single tracked in the suburbs. The company owns 800 horses, and runs 70 cars and busses.

A bill now in parliament provides for three miles of extension and the electrifying of the Kingswood-St. George line. The average day's work of the employes is 11 hours for trainmen. The cars are on duty 14½

vice-chairman of the meeting. The toast of the evening, "Success to the Bristol Tramways and Carriage Company," shows the spirit of the public toward the tramway.

One of the features of the tram traffic is a new double decked car, built by the Bristol Tramways & Carriage Company, and reproduced herewith in an engraving. It is called number 2, and carries 32 passengers, 16 inside and 16 out. It weighs 5,824 pounds, including the renumeration if not elegant advertising boards, and cost \$600. This car has extended platforms and steps, and doors of double the ordinary width, four feet instead of two. The simple spring fender in front of the wheels is another new feature, the invention of Mr. Challenger. This car has been adopted as the standard for the tramways, and will be built in the best style, and of the best procureable material. Mr. Challenger was the principal designer and superintendent of construction.

The various lines of the Bristol tramways lead to many places of historic interest. One of these takes the visitor to the world renowned Clifton suspension bridge, an



engraving of which we show, surrounded by romantic scenery, the objective point of all travelers, whether commercially or pleasure bent. The bridge is said to be one of the highest in the world, and offers numerous advantages for prospective suicides. In fact one of the principal duties of the bridge watchmen, is to keep a close eye on all wild looking people of suicidal symptoms. A curious instance lately, was that of a tired-of-life-and-crossed-in-love young woman, who jumped for death, but her skirts filled up with air, a la parachute, and she was landed gently in the mud, from whence she was hauled unhurt, but, wiser and sadder, to answer a charge of attempted suicide. The bridge is 32 years old, and weighs 1,500 tons. It will support a burden of 7,000. The single span is 702 feet 3 inches, and its height from the low water 287 feet. There are 4,200 links in its chain,



C. CHALLENGER.

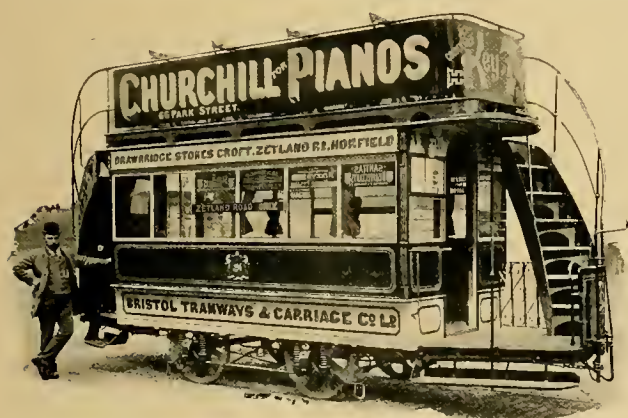

each 24 feet long and seven inches wide. They pass gracefully over the 70-foot towers, and are anchored 70 feet into the solid rock.

The management of the Bristol Tramway & Carriage Company, consists of President W. Butler, J. P., and directors, Messrs. Gardner, Low & Wethered. Of General Manager C. Challenger we reproduce a portrait.

**DISTRIBUTION OF ELECTRIC POWER IN EUROPE.**

The town of St. Etienne, France, seems to be rapidly arriving at the point of ideal electrical development in the way of distribution of electric power to small shops and factories. In the consular reports for May, Charles W. Whitley, Jr., describes the conditions of affairs there. St. Etienne is a workmen's town of 133,000 inhabitants, of which 30,000 of the most intelligent are weavers. Of the 18,000 looms in the city, the majority are owned by the individual weavers. They have until recently been worked by hand, but the weavers are beginning to find that with electric motive power they

can increase their output, and electric motors are accordingly coming into extensive use in the small shops. The power is furnished by the Edison Electric Company, from a 900-horse-power water-power plant on the river Loire. There is also a ribbon factory using electric motors in place of the usual shafting and belting, thereby adding another to the list of modern factories using this advanced method.

**MUST BURY THE WIRES.**

The Board of Aldermen of Boston has ordered the removal of all overhead feeders and returns of the West End Street Railway, and give until November 15 to put them underground. The telegraph and telephone companies and electric light companies must also obey this rule. The down town and crowded portions of the city are alone specified.

**STREET RAILWAY EARNINGS IN ST. LOUIS.**

The decrease in passenger traffic of the late "hard times" is well illustrated by the last quarterly report of the St. Louis street railways. The total trips were 1,313,949, against 1,469,513 for the first quarter of '93, and the passengers were 20,953,841 in '94, against 21,485,054 in '93. The Lindell railway increased its traffic over 1,000,000 in spite of the depression.

**THOMAS' LIFE FENDER.**

The fender illustrated herewith is the invention of Charles F. Thomas, Buckeystown, Md. It is in the form of a catch net with a frame which bends inward as a heavy body falls into it. The frame is carried on the truck frame or on a supplemental frame as necessity

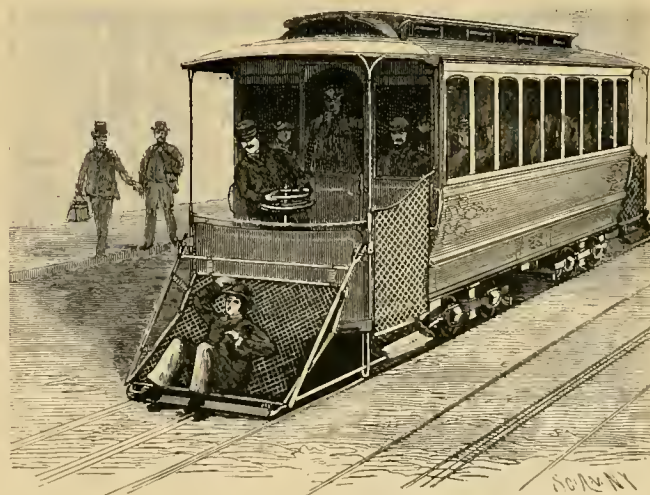

requires. The striking edge may be padded. As the person is struck and falls upon the net the helical springs of which it is composed close him as in a purse or bag and prevent further injury from falling again on the track as might be the case if the springs were less flexible. This fender is open to the objection that obtains in all flexible fenders, namely, lack of strength.

## HALF FARES.

Interesting Bits of Information from all Parts of the Country,  
Boiled Down for Busy Readers.

THE South Chicago and Calumet lines of this city are making preparations to burn oil as a fuel.

THE Buffalo & Williamsville has utilized a newly-discovered gas well by piping the product to its boilers for fuel.

JESSE SELIGMAN, of the great New York banking house, is dead. He was a large holder of street railway securities.

THE Brazilian war is at an end, and the tramway lines in Rio no longer have use for the sign, "Take this car to the naval battle."

CONSIDERABLE idle talk of a strike of Chicago street railway employes was the main topic of the sensational evening sheets during the month of April.

H. R. BILL 6724, authorizing the extension of the Columbia Railway of the District of Columbia, is under the consideration of District commissioners.

A VERY fleshy woman fell in front of a Broadway (N. Y.) cable car the other day, but her corpulency saved her life. She was too fat to get under the wheels.

THE Brooklyn goat is the latest victim of the d--ly tr--y. He very frequently tries to eat the loaded end of a trolley wire and the consequences are heart-rending.

THE Windsor Beach Electric Railway, near Rochester, N. Y., will be opened April 20, and the pleasure resort business begun in earnest. A new pavilion is being built.

THE Ridge avenue line of the Philadelphia Traction Company was put into commission April 18. President Widener, W. L. Elkins and distinguished guests made the trip.

THE Ohio vestibule case, which was fought by the Springfield Railway Company, was prepared and conducted by Oscar T. Martin, a leading attorney of central Ohio.

THE Fort Meade, Fla., Street Railway is one of the successful Southern roads, having paid an 8 per cent dividend for the past two years. J. G. Carter is general manager.

FREIGHT hauling is the greatest question now under the consideration of the electric railway managers in Jersey City, Newark, the Oranges and that section of New Jersey.

MOUNTED policemen in New York City will hereafter be provided with nickle mounted lanterns with half green half white lights. The idea is taken from the cable car warning lights.

AN old colored woman in New York, on her first attempt to cross the cable tracks, was so frightened that she gave up in despair and walked around the loop rather than cross.

BALTIMORE is boiling over, that is in the pro bono publico columns of the papers, concerning the high-step evil of the rapid transit car. It is said to be particularly injurious to the ladies.

THE bill in the Ohio legislature, allowing municipal corporations to buy, construct and own street railways, and upon a two-thirds vote to issue bonds to pay for same, was defeated in the Senate.

A HARMLESS little garter snake recently got loose in a New York horse car and stampeded everybody except one man who had several drinks aboard and said he never gave way to his imagination.

THE city council of Philadelphia has established a standing committee on "street passenger railways." It consists of twelve members of each chamber, but the chairman must be a member of the select chamber.

THE Chicago, Burlington & Quincy Railroad Company and the West Chicago Street Railroad Company had an interesting altercation over a grade crossing recently, in which the street railway hosts came out victorious.

PROFESSOR BEMIS has decided that all street railway, gas and electric light plants should be owned by the municipalities. This is not a new thing, professor, and the street railways go on owning themselves just the same.

THE Atlantic Avenue Railway Company of Brooklyn has bought three of the electric cars used on the Intramural for use on its Coney Island and 39th street ferry line. If successful there they will be used in the city also.

THE report generally circulated that the Canadian Pacific Railway had decided to adopt electricity on one of its heavy grades on its Rocky Mountain Division is, we are informed by Assistant General Manager Tait, incorrect. It was considered, but cost was too great to warrant.

THE life fender in use on the Springfield Avenue Street Railway line, of Newark, N. J., the invention of Foreman Smith, of the Irvington line, recently distinguished itself by picking up a big Newfoundland dog. When the car was stopped Mr. Dog jumped out and ran away, without so much as a wag of thanks.

THE Brooklyn, Queens County & Suburban Railway Company has awarded contracts for twenty-five miles of 90-pound girder rail to the Johnson Company, and for fifty cars to the Lewis & Fowler Manufacturing Company.

RICHARD C. BEGGS, ex-secretary of the Oakland Consolidated, who was sent to the penitentiary for absconding with \$10,000, has been released. The release gives general satisfaction, as Beggs has fully expiated his crime.

PRESIDENT VREELAND, of the New York Metropolitan Traction Company, writes us they have received about 3,000 applications for the \$50,000 prize. When it comes to novel transit, Coxey's army isn't in it with the Metropolitan contest.

THE Mohawk & Illion Horse Railway, of Illion, N. Y., reports for the quarter ending March 31: Gross earnings, \$1,715; operating expenses, \$1,144; net income, \$511. The net income for the first quarter of 1893 was \$502.

L. R. SHELLENBERGER, Atlanta, Ga., chairman of the local committee on exhibits, for the October convention of the American Street Railway Association, is the assistant engineer of the Johnson Company, of which Wm. W. Kingston is the Southern agent.

WHEN the John Stephenson Car Company of New York City ships a car to a foreign port, the vehicle is boxed complete, knocked down. The total weight of the usual car for South America is 6,500 pounds with the box, and the package measures 27 feet by 8 by 4 feet.

JUDGE PARKER, of Kingston, N. Y., has granted a new trial in a damage suit brought by a woman who gained \$2,500 damages from the Troy City Railway. The company now is prepared, it is claimed, to show that the damages resulted from an abortion. The company alleges blackmail. It will prove an interesting case.

THE relative amount of securities of the two great electrical concerns is given as follows:

Westinghouse.	General Electric.
\$ 692,000.....bonds .....	\$10,000,000
3,600,000.....preferred stock.....	4,000,000
5,400,000.....common stock .....	30,000,000
9,692,000.....total .....	44,000,000

A NEW YORK saleswoman has been arrested on the charge of blackmailing a street railway company. She received a \$6,000 judgment against a street railway company some time ago on account of an alleged broken ankle. A detective has discovered that her ankle was otherwise broken and a scheme concocted to bleed the company.

It takes presence of mind to be a successful electric car conductor. For instance, the other day in a neighboring town a car ran away down hill, jumped the track

and stopped before the very door of a "prominent citizen." When the startled p. c. rushed out to find the reason of so much tumult, there stood Mr. Conductor, cap in hand, saying, "Did you order a car, sir?"

THE change in the management of the Niagara Falls Park and River Railway, places C. R. McKenzie, well-known as connected with the Montreal road in the general management. Mr. McKenzie's ability as shown in his previous connection has, in this relation, ample opportunity to display itself. W. A. Grant, ex-manager, returns to steam railroading on the Canadian Pacific.

THE enterprising Parisian newspaper, the Petit Journal, has offered a prize of \$2,000, a second prize of \$500 and a third of \$400, for the three most deserving self-contained "horseless carriages" for roads. Vehicle must carry at least two persons, and run at least six miles an hour. The competition closed April 30, but to date no awards have been published. The Journal staff were the judges.

PROFESSOR SHEPARDSON, in one of his recent interesting "talks" in the American Mechanic, says: "The writer has heard of one conceited 'electrician' in a small town, who found great pleasure in telling his visitors that when his plant was put in by the company it required 110 volts and 80 amperes, but he had improved it so that he had done away with volts entirely and did not use them any more."

WE are in receipt of \$2.00 in stamps enclosed in an envelope postmarked San Francisco, with one of our subscription blanks, but which bears no name whatever. As our San Francisco list of subscribers is very large it is impossible for us to know to whom to credit this amount, and if this item should reach the eye of the remitter we should be glad to have him advise us so that the amount may be passed to his credit.

THE Rabbinowitz family has a large sized crow to pick with the Kansas City Cable Company. Harry R. wanted \$2,000 for an alleged broken rib. Bertha R. wanted \$5,000 for bruises and wounded feelings. Frank R., the latter's husband, wanted \$2,000 for the loss of his wife's society and service. The first two were given \$200 each by the benevolent jury, and a big sigh of relief will be properly heaved by the company when the Rabbinowitzes are disposed of.

THE Terre Haute, Ind., city council has passed a "hitching-on" ordinance that rejoices the heart of the conductors and the Street Railway Company of Terre Haute. It makes it unlawful for any one to mount a street car unless with the intention of becoming a bona fide passenger, and prohibits the hitching-on of any person under 16 years of age in any manner whatsoever. The person or child violating this ordinance may be fined in any sum not exceeding \$25, on conviction before the mayor.

## FOREIGN FACTS.

WORK will be begun on the Mandelay, India, tramways this summer.

THE Creusot Works will exhibit an alternating current street railway system at the Lyons, France, exposition.

THE long eared portion of the citizens of Bristol, England, is organizing against the introduction of electric cars.

ON March 30 the Hamburg, Germany, Electric Railway was commissioned. It has  $21\frac{3}{4}$  miles of line and 42 cars.

A SYDNEY, Australia, capitalist wants to put in a cable railway between the terminus of the present Perth, Scotland, tramway and Mount Magnet.

THE Paris Chief of Police forbids the carrying in public conveyance of any dirty, overlarge or ill-smelling package. It is an idea worthy of imitation.

ON the Austrian state railroads recent disasters from explosion of gas and oil have been so numerous that there is a strong probability that electric lighting will be made compulsory.

THE success of the overhead electric railway of Liverpool has tempted the company to build an extension to the Seaforth Sands Station. The total line will then measure  $6\frac{1}{4}$  miles.

THE London Tramways Company is running a car on its line in which storage battery, incandescent lamps are placed. One lamp is placed upon an iron frame six feet above the car roof, for the use of "outside" passengers.

A STATION indicating device is in use on the Albert Dock railway, London, gives satisfaction. At a certain place just before arriving at a station a lever is struck by a raised block between the track. The name of the station is brought into view.

THE new Isle of Man Tramways & Electric Company, England, has a capital stock of \$75,000 and will consolidate the Douglas Bay Tramway and the Isle of Man electric. Extensions will be made and the entirety of the Manx country will be traversed by the motor car.

THE Anglo-Argentine Tramways Company, a London corporation working the street railway lines of Buenos Ayres, reports a dividend of 43 cents a share and \$10,000 credited to the reserve fund for the year 1893. The running expenses were \$604,690, the receipts \$799,970.

J. H. WOODWARD, the prominent English electrical engineer, whose name is so intimately connected with the installation of the Liverpool Overhead railway, has severed his connection with the electrical construction company (Elwell-Parker) and has opened offices at No. 6 Brighton Terrace, Merridale Road, Wolverhampton, England. He is now absent on a six weeks trip on the continent.

THE British police raid a tram car that is supposed to be "overload," that is, carrying more than it can seat. On such an occasion recently the excited conductor pulled off his cap, badge and register and sat down among the passengers, hoping thus to escape detection. His ruse was of no avail, as his excitement betrayed him.

THOMAS PARKER, head of the extensive electrical works of the Electrical Construction Company, Wolverhampton, England, retires from the concern the last of this month, taking with him five members of the staff. Mr. Parker was the founder of the Elwell-Parker Company. His address will be Telkenhall, Wolverhampton.

THE International Tramway Union has changed its date of meeting from the 25th of August to the 18th of the same month. The meeting will last five days and include an extensive trip, visiting the more prominent German electric railway plants. The meeting proper will be held at Cologne. The dinners each day will be prominent parts of the proceedings.

IN 1885 the thirty-two miles of the Buenos Ayres, South America, tramways, carried 12,725,000 passengers, while in 1893, with two miles more of track, 25,583,000 people were carried. In 1888 the dividend paid was 10 per cent. The present dividend is  $3\frac{3}{4}$ . The fares were raised last year 25 per cent, but the increase in labor and price of forage counterbalanced the rise. Better try electricity, brethren!

AN English engineer, the inventor of a radial truck, recently suspended himself in a hammock underneath a car equipped with his device and attached to an express train. To his horror after a few miles he saw that the swing of the hammock had worn through one of the attaching ropes. Luckily, however, the train soon approached a station and the engineer crawled out with all the data he cared for.

DURING the past year an electric railway has been constructed and commissioned at Genoa, Italy. The feeders are carried on brackets attached to the houses and the trolley wires are 23 feet above the ground and strung in the same manner. The station capacity is 450 horsepower, and Siemens-Halske electrical equipment is used. A wire frame is used instead of a trolley wheel. Twenty-four cars are in use, each equipped with two 18-horsepower motors. The Electric & Cable Railway Company of Kerns, Switzerland, built and owns the road.

THE KHEDIVAL GOVERNMENT, through the minister of public works, announces an extension of six months for receiving bids for the proposed concession for the construction of a street railway line in Egypt. This makes the last date August 1, 1894. The concession is a monopoly of street traction and is attracting considerable attention. The American consul-general is Frederick C. Penfield, Cairo, Egypt. American capital might here find an excellent opening. Investigation shows good reason to believe the venture will be successful.

**THE SANDUSKY, MILAN & NORWALK  
ELECTRIC RAILWAY.**

Longest Interurban in the Country—Built During the Panic by  
Local Investors—Passengers, Freight, Express and Mail  
Combine to Furnish a Splendid Business.

The projection of this interurban road and its successful completion in the face of the financial disasters which spread over the country during its construction, is one of the most gratifying results in electric railroading it has been our pleasure to chronicle, and a short sketch of its history will certainly be of interest to those who contemplate similar enterprises. It comprises nineteen miles of track, which is the longest road of its kind on record, and Sanduskians may well feel proud that they have in their midst an element of enterprise such as has been displayed by the projectors in the building of a line of such proportions. Sandusky is situated on Lake Erie, midway between Cleveland and Toledo, and has a population of about twenty thousand. There are already two electric roads within the corporate limits of the city, both of which were built by the projectors of the present line. In the summer season excursionists come into Sandusky from all directions to visit the Ohio State Soldiers Home or to take the steamboats plying between Sandusky and the islands of Lake Erie. Cedar Point, another celebrated summer resort, draws thousands to the city, and both roads are kept busy. The Sandusky, Milan & Norwalk interurban line commences at the State Soldiers Home, where it connects with the city lines, over one of which The Peoples Electric Railway, a traffic arrangement, has been made, and the Sandusky, Milan & Norwalk cars are thus enabled to bring their passengers to



ON THE BEACH, CEDAR POINT.

the heart of the city and direct to depots and boat landings, thus avoiding the transfer of passengers.

From the Soldiers Home the line extends south on the west side of the highway, the franchise from the county commissioners stipulating that the track shall not encroach nearer the center of highway than fifteen feet. About one mile south the first trestle 300 feet long and 10 feet high is crossed. Still further south, about one a half miles, a picnic ground and pleasure garden has been opened up and bids fair to become a popular resort and

a source of income for the road. There is a slight curve in the road at this point which, when turned, opens up to view a straight piece of track extending across a prairie for a distance of five miles. Substantial farm houses and prosperous looking farms extend along on both sides of the track. After crossing the prairie a turn is made and the first 6 per cent grade is encountered, this grade being also on a curve. About one mile from here the road crosses the Nickel Plate at Avery, crossing it at grade



DEPOT AT SOLDIER'S HOME,

and close up to the station platform, which makes it convenient for transferring passengers and express matter. From Avery a straight run of two miles is made through a rich farming section, where large quantities of strawberries and other small fruits are raised, and which when in season will be a source of revenue to the freight and express department of the road. The next five miles of the line run through a very broken country, and it is over this latter portion of the line that the projectors showed their backbone in overcoming the obstacles which stood in the way. The power house was located in this valley on account of the proximity of water, coaling facilities of the Wheeling & Lake Erie Railway, and nearness to the heaviest grades on the road.

From North Milan Hill the valley below is reached by a maximum grade of 8 per cent, although the highway has a grade of over 20 per cent, but by cutting down the summit and trestling, the foot is reached with the grade mentioned above. The river is crossed over an iron truss bridge 165 feet long, and after making a severe curve crosses the Wheeling & Lake Erie steam road at grade and then winds up on a side hill, making a climb of 65 feet in less than 800, all of which grade is on a reverse curve. This is the most difficult grade encountered along the whole line, but the heavy cars with their double equipments and heavy loads have no difficulty in making the climb. At the top of this grade we enter the village of Milan, a picturesque little town of about 1,500. There are many fine residences to be found here and the inhabitants would not part with their electric railroad for a good deal. They are all good patrons of the road, and it cannot but prove a benefit to Milan in many ways. Leaving the village of Milan the road continues south to the city of Norwalk, a distance of five miles more, pass-



FIVE MILES ACROSS THE PRAIRIE.

PAVILION AT CEDAR POINT.

STEAMBOAT LANDING, SANDUSKY.

ing over some very wide and deep ravines, all of which have been trestled. The longest is 800 feet and the highest 30 feet. The line enters Norwalk from the east end and extends down the main street to a point opposite the court house, a distance of about two miles. It is the intention to extend the line about two miles further, taking in the entire length of Main street. Norwalk is a thriving city of 10,000 people and is the county seat of Huron county. It is intended to put on a local service in Norwalk when the extension is completed, and as business may warrant it other extensions will be made.

The construction of the railway was commenced in December, 1892. The estimates were made by Thomas Wood, the present manager, and were \$155,000, covering the entire line construction, real estate, buildings, machinery, cars and electrical equipment. This amount was to be realized by the sale of \$80,000 stock and \$75,000 of bonds.

The entire construction was placed in the hands of Mr. Wood, who has already constructed other lines, and the road to-day speaks for itself as to the success or failure of his efforts. Grading of the roadbed began in December, 1892, and was completed to Milan in fifteen days. Operations were suspended for the winter, but poles and ties were distributed along the lines with sleds. A locomotive and four flat cars were purchased for use in construction and they proved a good investment. In March construction began again, although the snow was three feet deep, and track was laid on top of it. Several

miles were built before the snow melted enough to let the track down to the ballast. All went well till June came, and the projectors learned that the parties who were to take the bonds could not carry out their agreement. This came as a stunning blow, for \$80,000 had been spent and as much more was contracted for. However, with personal loans and with the receipts of one car running between Milan and Sandusky, construction work was kept up a while longer. Finally it was thought best to appoint a receiver until such time as the bonds should be negotiated, and Col. J. C. Gilchrist was given that office. It was an impossibility to place a bond of any kind with any bank, and the promoters realizing this did not try to do so, but sold them in lots of one and two in the country through which the road is built. The entire amount was placed within thirty days at par; a very gratifying result, and one that showed the local faith in the enterprise. The opening of the entire line occurred August 28, seven weeks after the date set, and although those seven weeks would have been most profitable ones, the stockholders felt that they had cause to congratulate themselves that affairs turned out as well as they did, after the very discouraging aspect of two months before. The receiver was discharged after sixty days service, and all creditors have been paid in full.

The rail is principally 48-pound T, with some 45-pound girder. The ties are cedar except on curves and trestles, where oak is used. The trestles have been well tested with car loads of stone, but it is the intention to

fill them up. The poles are all set in six feet of concrete. The power house at Milan contains two 150-horse-power Babcock & Wilcox boilers, two 150-horse-power McIntosh & Seymour compound engines and two Westinghouse multipolar generators of a like capacity. All the electrical apparatus is of Westinghouse make, this being the third road built by these projectors employing Westinghouse machinery. The equipment at present consists of three closed coaches 40 feet in length having double trucks; three open coaches of the same length and one 16 foot vestibuled car for service in Norwalk. One of the coaches is a combination passenger and express. All the cars are upholstered with plush and all windows are beveled French plate. The trucks are all from the McGuire Manufacturing Company of Chicago, and are doing good service. Each car has two 30 horse-power Westinghouse motors under it, and a speed of 25 miles is attained on level track. The road was opened for through traffic August 28, 1893, and from that time to the present the cars have been well filled and the prospects for the road are very promising. The coming summer will in all probability tax the capacity of the road to its full extent, and the stockholders are to be congratulated on the outcome of the efforts of the projectors and active members of the enterprise.

The road has a contract for carrying the United States mails to six post offices twice a day. A five years contract has been made with the American Express Company for carrying its business. The company has realized quite a revenue from carrying freight since opening the

line, and it is growing daily, so that it will soon necessitate regular freight cars.

A ride of 42 miles for 50 cents, is certainly an inducement for travelers to take the Sandusky, Milan & Norwalk Electric Railway. Arrangements have been made by which the Sandusky, Milan & Norwalk sells tickets at its offices to points east and west over the Nickel Plate, and mileage tickets of several roads are honored by the conductors of the Sandusky, Milan & Norwalk. This makes it very convenient for traveling men, and they are not slow in appreciating it. We look upon this project as being one of the most enterprising ones yet entered into by electric railroad men, and the fact of the project being, as it is, an assured success will undoubtedly lead to the building of many more similar lines. The present management consists of Geo. H. DeWitt, president; Thomas Wood, secretary and manager, and A. W. Prout, treasurer.

Ohio seems to be one of the favorite states for interurban projects, and it is well suited for them, combining prosperous farms with numerous large towns. The report of the Ohio Road Commission to the last legislature of that state showed a full recognition of the important part to be played by this class of roads in the future. This commission, of which Martin Dodge is the chairman, and leading spirit recommended that no money be spent in expensive road improvements as electric railways furnish a much cheaper means of transportation at a less outlay of capital. It was shown that \$1.25 would haul a ton five miles by horse-power on a wagon road, twenty-five

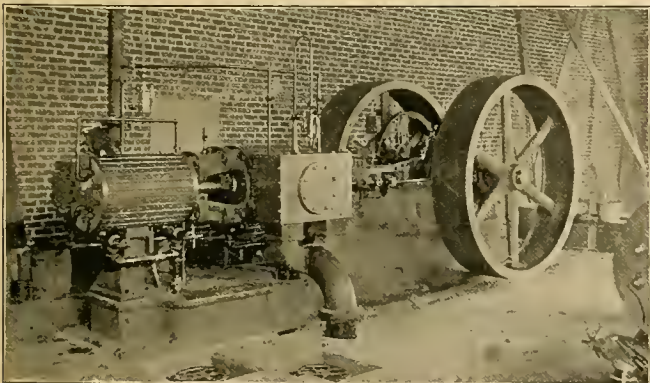

700-FOOT CURVED TRESTLE.  
MCINTOSH SEYMOUR ENGINE.

IRON BRIDGE OVER HURON RIVER.  
GRADE AT RATTLESNAKE CREEK.

miles on an electric railway, and 250 miles on a steam railroad. The majority of the commission reported in favor of masterly inactivity on the part of the legislature, thus leaving the field open to the electric road built by private enterprise. The minority report went farther



G. H. DE WITT,  
*President.*

and pointed out that it was by the free use of the highways that such cheap rates are made possible on electric roads, so that "public aid though not public money has

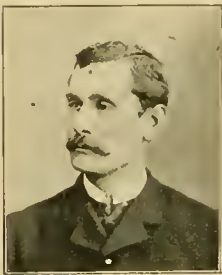

THOS. WOOD,  
*General Manager.*



A. W. PROUT,  
*Treasurer.*

been given, and properly given to cheapen transportation by that means." Thus the state has helped in a great improvement without straining itself financially or parting with any rights previously enjoyed.

THE report that Henry M. Whitney is to resume the presidency of the Boston West End is branded as false by Mr. Whitney.

## STANDPIPE ACCIDENT AT PEORIA.

The Water Company Tries to Evade Responsibility by Crying Electrolysis.

On March 30, last, the steel and wrought iron standpipe, 25 by 120 feet, at Peoria, Ill., was broken close to the foundations, and falling, occasioned several deaths. A high wind, fully thirty miles an hour, prevailed at the time. Expert examination, under the direction of the coroner and others interested, revealed the fact that the interior of the sheets forming the pipe were corroded in the form of blisters or excrescences, composed of layers of brown and black oxide. Beneath the second coating the plates were pitted in some cases to a depth of one-eighth of an inch, but on removal revealed a clean metallic surface. These blisters extend all the way to the top, and are observed, also, in the other tower on the east bluff.

The water company, in its anxiety to shift the responsibility for the accident on other shoulders, have asserted that the accident was caused by electrolysis, as the Ft. Clark electric line passes in close proximity to the tower, and one of the water mains leading out, is laid in the same street with the road for a half mile. The Peoria Journal prints an open letter, dated April 6, from the water to the railway company, as follows:

GENTLEMEN:—You are hereby notified that the Peoria Water Company for a long time past has been, and is now, daily suffering and sustaining great injury and damage to its lead and iron pipes, and other underground property in the streets and alleys of Peoria. That it is put to great labor, expense and trouble in making and keeping up repairs on its said pipes, by reason of the improper and wrongful use by you of the ground as a return conductor for electrical currents; and by the illegal, careless and improper use of electrical currents generated by you.

You are also notified that by reason of such improper, wrongful and illegal use of electrical currents by you, the Peoria Water Company is not only suffering great loss and expense in connection with its lead and iron pipes and other underground property, but it is greatly hindered, delayed and injured in the conduct of its business, the furnishing of water to the city and citizens of Peoria, Ill.; and if such improper, illegal and wrongful use of electricity and electrical currents is continued by you, it is only a question of a short time when this company will, by reason thereof, be so injured, delayed and hindered in its business as to be prevented from conducting and carrying on its said business.

We are informed that you are about to undertake the extension of tracks and the use of electricity in the streets of the City of Peoria beyond the present limits of your street railway lines; and that the construction of the extension and the use of electricity will be the same as is now in use by you; and we wish to protest against all such extensions,

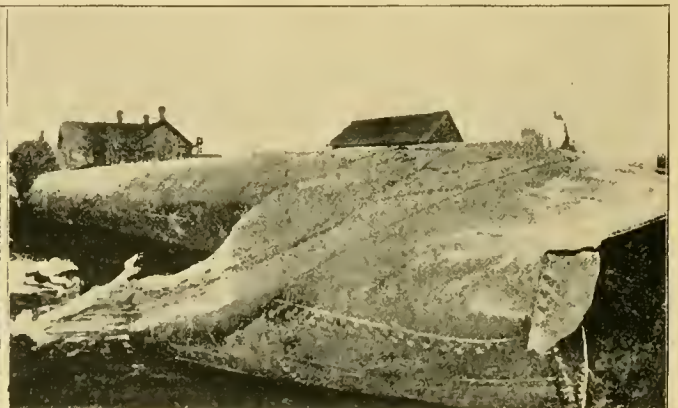

THE STANDPIPE ACCIDENT, AT PEORIA.



and request that you not only do not make such extensions and further use of electricity in the manner above specified, but that you immediately cease and desist from the improper, illegal and wrongful use of electricity and electrical currents as herein before specified.

You are therefore notified that this company and its receiver will hold you responsible for loss, injury and expense suffered, or that may be suffered, by it, through the wrongful, improper and illegal use of electricity and electrical currents by you.

Yours truly,  
 DABNEY H. MAURY, JR.,  
 Supt. for the Receiver.

The answer of the railway people was promptly made, under date of April 10, and sets forth the policy of the road in the matter.

DEAR SIR:—Your favor of April 6th, to the Fort Clark Street Railway Company, has been forwarded to me for consideration.

I was not aware of the fact that the Peoria Water Company had the exclusive use of the earth within the City of Peoria; if we had known such was the fact, we would have applied to you for the franchise, instead of to the common council.

We have been led to believe that the law of the street was plain, and that they were devoted to the public for the purpose of conveying passengers by different methods.

It is our intention and purpose to use the rails of our railway for conveying the return circuit, and I may call your attention to the fact that when the late franchise was granted to the Fort Clark Street Railway Company, the Peoria Water Works Company's representative did all in his power to prevent having the ordinance passed, so that we could not use the rails.

In regard to the extension we propose to make, we would refer you to the common council, who require us to make that extension; the rails at the present time are on the ground; the poles are erected, and we hereby notify you that we shall comply with our ordinance unless restrained by the courts.

From the recent accounts in the papers we would assume that your trouble was more above the ground than under it. If you are not able to build a satisfactory standing pipe that is above ground, it certainly would look as if you would not properly put in any underneath the ground that would stand ordinary wear and tear.

It would seem that the trouble with your water works plant is general debility, resulting from other causes than that of the electrical current that is used in propulsion of cars within the city of Peoria.

Yours respectfully,  
 F. W. HORNE, President.

The claim that electrolysis had anything to do with the accident is absurd, and furnishes a mighty thin defense, which cannot hope to stand, but will fall to the ground in shorter time than the ill fated tower. The fact that the oxidation, on which so much stress is laid, extends all the way to the top, and many feet above the high water mark, should alone wipe the electrolysis story from the slate.

Our illustration is reproduced from Engineering News.

THE construction of fifty new motor cars and fifty trailers has been commenced in the Toronto Railway Company's shops. From these shops 180 cars have been turned out. These cars are in use in Montreal, Winnipeg, and elsewhere.

THE London authorities have decided that an electric van or omnibus is a locomotive within the meaning of the law.

THE Lake Street Elevated Company, of Chicago, has taken the road out of the hands of Underwood & Green, the contractors, and assumes entire control of the road.

A HOME MADE PIPE WRENCH.

Necessity that is the mother of invention and the opportunity of the good mechanic, was the occasion of the use of the ingenious pipe wrench shown in our engraving. The Scientific American recently saw a mechanic who desiring to unscrew a pipe, and not having the requisite tool improvised an effective implement by taking a

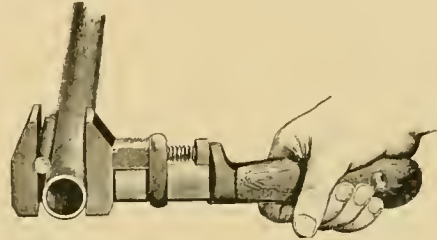

round file and fitting it in the jaws of an ordinary wrench as shown, loosening the pipe without difficulty. The rough file prevented slipping, and the wrench did the rest. It has been said by a prominent professor of mechanics that a well equipped laboratory was often more hindrance than help, as the student would depend on what was afforded rather than use his brain.

THE NORTHWESTERN L.

The franchise obtained by the Northwestern L, some months ago, from the Chicago city council, is about to be acted upon by the promoters of the enterprise. It has been decided to condemn a strip 40 feet wide through the business houses on its right of way from the river south to the alley just north of the First National bank, and then east to Wabash avenue. As now proposed, the line will go through the second floor of the buildings, a la arcade.

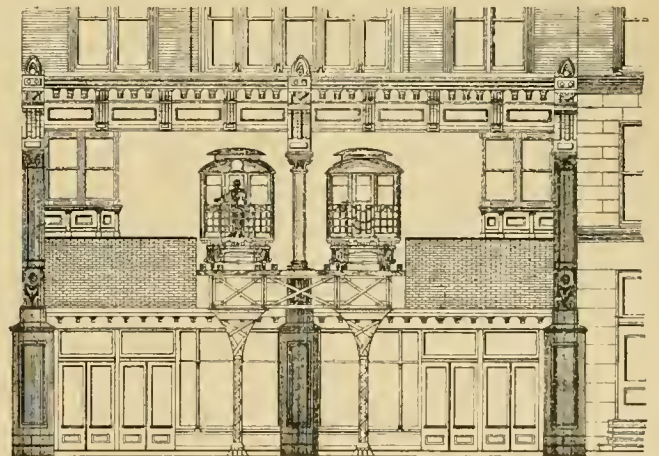

The Columbian Construction Company, with offices on the fifth floor of the Rookery, will build the line, and right of way is now being gained, and such men as P. D. Armour, C. T. Yerkes, John J. Mitchell, Marshall Field and L. Z. Leiter, are said to be intimately connected with the enterprise. D. H. Louderbeck is the formal head of the enterprise. Our illustrations show proposed method of tunneling buildings.

## SOME FOREIGN TICKETS.

The case of foreign street car tickets which many will remember as a part of the STREET RAILWAY REVIEW'S World's Fair exhibit, was a most interesting assemblage of these "common carrier's exchange."

We represent here a few of the most interesting of the number and begin with the most difficult, at first sight, printed in the musical Russian tongue. The one marked 88041 will give the passenger one ride on the Nevskii Prospect, the world renowned thoroughfare of the capital of all the Russias. It is worth five kopeks or 2½ cents.

the months are noted by letter and the route by the double row of names. It is worth 20 pfennigs or about five cents. It is only good for a continuous ride in the direction in which the passenger set forth and in the next available car. The conductor's number is stated and the ticket must be shown to the inspector on demand. Berlin's contribution is numbered 09545 and is worth 2½ cents to travel on the circular or belt line to Georgplatz, Bremen. The horse-shoe ticket from Bremen is a receipt in full for 15 pfennigs, which must be kept during the journey and shown when required.

From old Barcelona comes the one headed vale 15

\$0.60  
 FERRD-CARRIL DE SAN MARCOS  
 Primera Clase.  
 San Juan de los R'anos  
 á  
**Sán Márcos.**

\$0.94  
 FERRO-CARRIL DE SAN MARCOS.  
 Segunda Clase.  
 San Juan de los Llanos  
 á  
**PUEBLA.**

\$0.28  
 FERRO-CARRIL DE SAN MARCOS.  
 Tercera Clase.  
**PUEBLA**  
 á  
**San Marcos.**

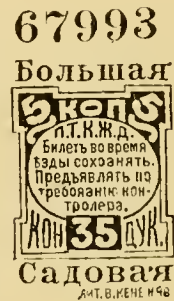
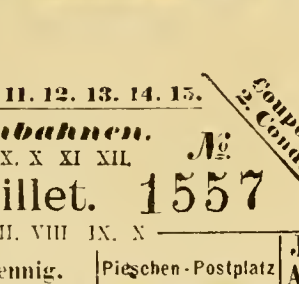
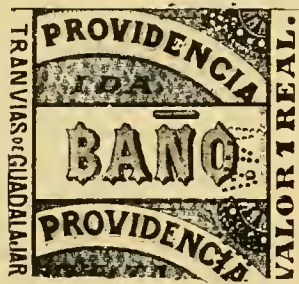
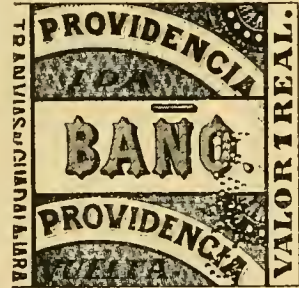

Bueno por un pasaje de la Plaza Hidalgo á la Estación Nacional  
 Plaza Hidalgo to National Depot

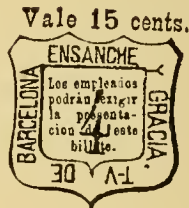
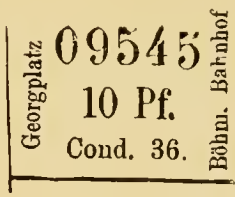

Dat.: 1. 2. 3. 4. 5. 6. 7. 8. 9. 10. 11. 12. 13. 14. 15.  
**Dresdner Strassenbahnen.**  
 Zeit: Vormittag VII. VIII. IX. X. XI. XII. №  
**Umsteigebillet. 1557**  
 Nachm.: I II III IV V VI VII VIII IX. X  
 Alberthr.-Reichsstr. **20 Pfennig.** Pieschen-Postplatz  
 3. Bahnh.-Tannenstr. Nur gültig, wenn die zweite Plauen-Postplatz  
 B. Bahnh.-Lämmchen Fahrt in direkter Fortsetzung an die erste erfolgt — Ohne Strehlen-Neumarkt  
 Leipzig-Georgpl. Garantie für sofortigen Anschluss, noch für Platz im Waldschl.-Postplatz  
 Löbtau-Postplatz nächsten Wagen.  
**COND. 36**  
 16. 17. 18. 19. 20. 21. 22. 23. 24. 25. 26. 27. 28. 29. 30. 31.

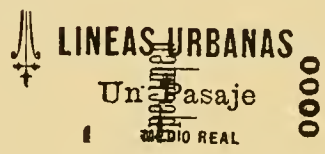

It must, like all European tickets, be shown on demand to the conductor or inspector. Number 97,127 is like unto the former, but of a different route. Number 67,993 comes from Moscow and will permit the bearer to travel on Great Garden street, the great boulevard of the city of the Kremlin. Translated it reads P. T. G. A. (name of line); five kopeks; ticket for going; must be shown on demand of conductor; Bolshaya Sadovaya (great garden street).

Number 1557 is a transfer ticket from Dresden, Germany, on the Dresden Street Railway. The Roman numerals show the hour of the day; the date is in arabic;

cents. It is a suburban ticket and must be shown on demand of the employees of the line.

Mexican tickets, of which there is a large number of various denominations, make up the rest shown herewith. The City of Mexico uses generally a plain printed slip bearing the legend "Bueno por un pasaje," etc., which means, "Good for one passage from the Plaza Hidalgo to the National Station," with the same repeated in English. The three classes are represented in the suburban tickets which need no explanation, while the ornate affair from Guadalajara and the simple one passage, un pasaje, of Guanajuato close the list and this story.

MUNICIPAL PURCHASE OF TRAMWAYS.

The Court of Appeal, London, England, has heard the appeal of the London county council in the case of the Council vs. the London Street Tramway Company in re the award of the arbitrator for the sale of the undertaking to the city. The lower court sent back the award to the arbitrator ordering him to take into account in framing his award the past profits of the undertaking, with a view of arriving at the rental value of the parts of the tramway to be bought. The arbitrator refused to do this and the appeal was taken and upheld by the Court of Appeal. The Company held that the valuation should be based upon the purchase of profits, which would have made the price \$750,000. The Council held that the price should be the cost of construction less the depreciation, making the sum \$320,000.

This rule was adopted by the arbitrator "because he could arrive at the value in no other way." It is claimed by the council that no hardship is worked to the tramway

will run from 6 a. m. to 12:30 midnight. The trip will be made in 38 minutes including stops. Twenty centimes will be charged for any distance. The stations will be in the form of Kiosks and foot bridges will connect arriving and departing trains.

Our illustration shows the station de L'Etoile the foot bridge and details of the ascent and descent.

A NEW METHOD OF CREATING TRAVEL.

A western bank president has a habit of taking an airing each evening on the front end of a street car, absorbing ozone and throwing off the cares of business, while chatting with the motorman. The other night he met a genius, and his match.

After the usual exchange of courtesies the motorman said:

"Mr. Blank, you consider yourself a financier, I suppose?"

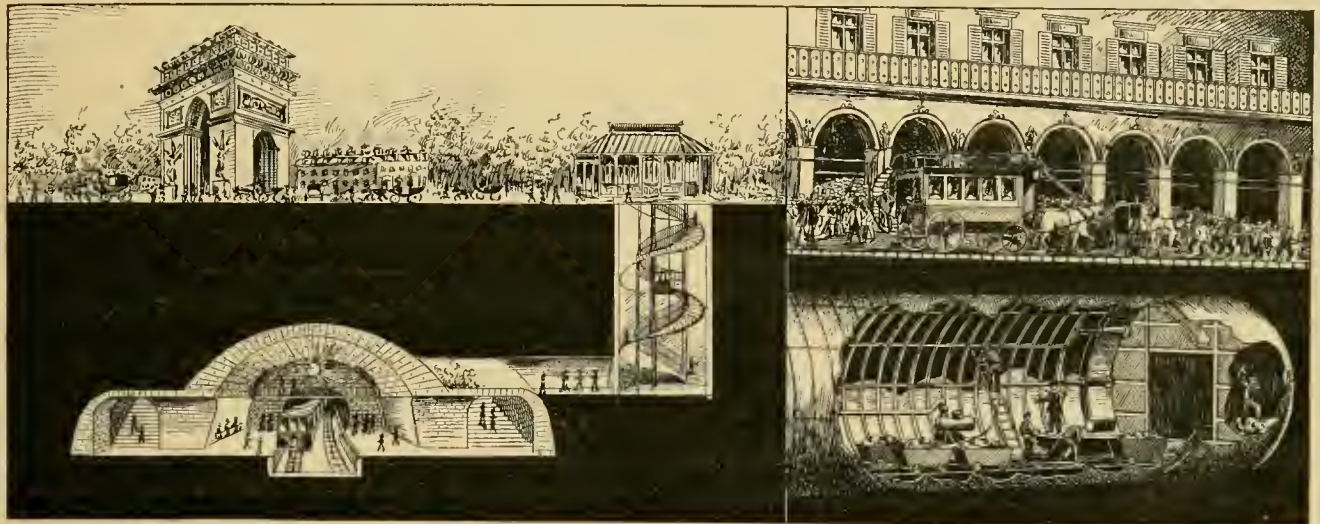

PROPOSED UNDERGROUND ROAD IN PARIS.

company because they paid nothing for the privilege, and the judges seem to think that the increase in value was an "unearned increment."

THE PARIS UNDERGROUND RAILROAD.

For the first city of the world, Paris is woefully deficient in the comforts of rapid transit. It is M. Berlier's plan however to obviate this difficulty of urban transportation and give Parisians an underground, tubular railroad from the Bois de Vincennes to the Bois de Boulogne. Seventeen stations will be placed on the route touching all the points at which "men most do congregate." The distance is 6¾ miles, and the route almost parallels the Seine. Our engraving shows the idea. The tunnel will be of metal, 16 feet in diameter with air shafts every 55 feet. The stations, cars and platforms will be lighted electrically, and the cars will be driven by electric motors. The trains will be made up of from one to four cars and

"Yes," replied the banker, "I guess I am, or I could not hold my job."

"Well, you don't know anything about financiering," the motorman made bold to state. "But my 'boss' (referring to the president of the street car company) is a first-class financier, he is. Why, do you know that every Sunday he advertises for a servant, and Monday twenty or thirty girls ride out to his house, near the end of the line, to get the place, but find madam can't see them; so they ride back, and repeat the journey several times, before they are finally told that the old girl has decided to stay a while. Now, that's financiering. Fifty cents paid out for advertisements, and \$8 or \$9 taken in for car fares, to swell the annual dividends of the boss' company."

THE report of funeral cars on the South Covington & Cincinnati Street Railway Company is denied by T. M. Jenkins, the superintendent.

### TOLEDO STRIKERS SENTENCED.

During the recent labor troubles on the Robinson lines at Toledo, O., a few of the strikers exceeded their prerogative to quit work, and harrassed the company by maliciously destroying property and grounding the trolley wire. They were arrested and brought before the grand jury which indicted three of them, namely: Oscar Austin, William Garber and Edward Scott. The first answered a charge of malicious mischief and the other two a charge of grounding the wires. The Robinsons generously refused to push the case and the men were thus saved a severe penalty.

Judge Pugsley said in passing sentence: "You look like men of intelligence and out of place here. However, you are guilty of grievous offenses. Perhaps you have acted in ignorance of the law. Still, you have done things you had no right to do. You had no right as a citizen, employee or anything else to ground the Robinson Company's wires. The prosecuting attorney has generously withdrawn these latter charges, or else you would surely have gone to the penitentiary. It is hard in this case for the court to be lenient, for you have committed a serious offense and it must be stopped in the future. An example must be made. As I said, it is hard for the court to be lenient, but if you promise not to repeat your actions in the future I will inflict as small a penalty as I consistently can, in the interest of public peace and order.

"Oscar Austin is sentenced to five days' imprisonment in the county jail and to pay a fine of \$25 and costs, to stand committed until paid.

"Wm. Garber ten days in jail and \$50 and costs.

"Ed. L. Scott ten days and \$50 and costs."

### KOHLER BROTHERS, THE NEW WESTERN AGENTS FOR THE WALKER COMPANY.

The result of the visit of Vice-President Billings and Professor S. H. Short of the Walker Manufacturing Company of Cleveland, Ohio, to Chicago, has been declared in the appointment of the Kohler Brothers to the western states agency of the Walker Manufacturing Company business. Since the death of the late J. L. Barclay, the Walker Company has been casting about to find a competent successor with the result above noted. The connection of the Kohler Brothers with the Eddy Electric



F. W. KOHLER.

Company will continue unchanged, and their offices will still be in the Monadnock building. The territory

assigned the new sales agents comprises the following states: The western part of Michigan and Indiana, Northern Illinois, with the entirety of Wisconsin, Minnesota, Iowa, Missouri, Kansas, Nebraska, South Dakota, North Dakota, Montana, Wyoming and Colorado.

The Kohler Brothers, Franklin W. and G. A. E. Kohler, have for two years represented the Eddy Company in the west with continued and deserved success. G. A. E. Kohler is a thorough street railway man, having been graduated from the offices of the North Chicago Railroad Company. Upon this was laid a considerable electrical training, in which may be included the formation of the firm of Kohler Brothers & Green. Franklin W. Kohler began his career in Philadelphia, but followed his brother to Chicago as above noted. Both gentlemen are well known in the electrical field and are genial and cordial in every business and social relation, and their friends will confidently expect continued and enlarged success commensurate with their increased field.



G. A. E. KOHLER.

### I. H. FARNHAM ON ELECTROLYSIS.

The paper presented by I. H. Farnham before the Institute of Electrical Engineers at New York, April 18, and at Chicago, April 25, was of interest as coming from the man who was the first to meet the trouble from electrolysis and who has studied the conditions as few others have. Mr. Farnham's personal experience was with lead telephone cables in Boston. Figures were given from voltage readings taken between cable coverings, pipes and rails, and it was made apparent that a very small difference of potential would cause considerable action. The first trouble discovered in Boston was in the summer of 1891, on telephone cable. The two suggestions that together were most helpful in curing troubles were: first, to connect the positive pole to the trolley, thereby restricting electrolysis to districts near the power house; second, to run copper feeders from the grounded pole of the station along the cables and connect it frequently to the cables. The two conclusions of most practical importance, drawn by the author are, that it is advisable to connect the positive pole of the dynamo to the trolley lines, and that a large conductor extending from the grounded side of the generator entirely through the danger district and connected at every few hundred feet to such pipes as are in danger will usually insure their protection. The author omitted to state, however, that this "large conductor" might as well be a well bonded track as anything else.

## THE NEW WESTINGHOUSE MOTOR.

The year, ending with our present issue, has been marked by the introduction of new railway motors by the three large companies engaged in this line of work. All these motors, while not radically different from the types previously manufactured, represent a distinct step in advance. They are mainly refinements of the forms manufactured by those companies for two or three years past. Such refinements are a part of the evolution of the machinery of any large industry. There are three improvements which are common to the new forms. The weight has been reduced, the motor entirely enclosed, and the dead weight on the axle partly taken off and supported by the truck springs. The original type of Westinghouse single reduction motor has been on the

the wire in each path is under the two upper field poles, there can be no unbalancing of the armature caused by wear of the bearings.

The form of the field castings and methods of opening the motor can be clearly understood from the engravings, as can also the spring suspension. The lower half only is hinged. The upper half is cast solid with the side frames which were a feature of the old motor. The top casing has one opening, which is above the commutator. The bottom casing has three openings, one at each end and one below the commutator. The motor is suspended entirely from the top.

The blocks holding the armature bearings are bolted to both upper and lower halves, so that the armature can be either left in the upper part or swung down with the lower. By this construction and arrangement of parts,

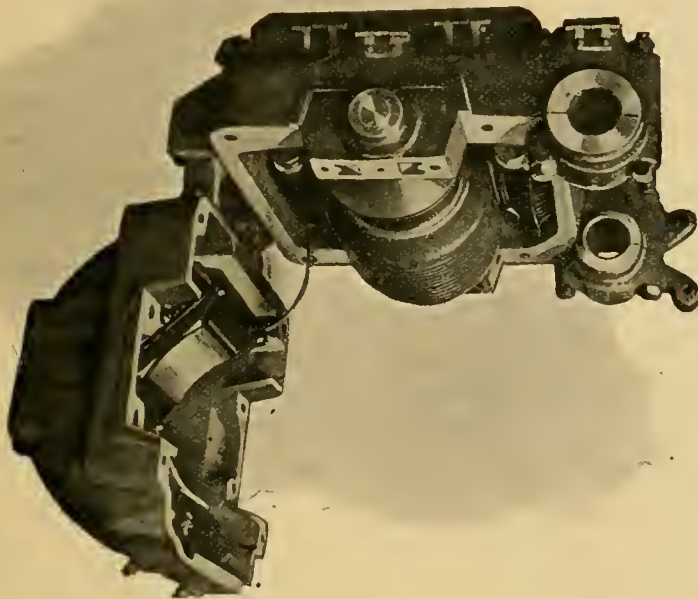

SINGLE REDUCTION RAILWAY MOTOR, OPEN WITH ARMATURE IN UPPER FIELD.

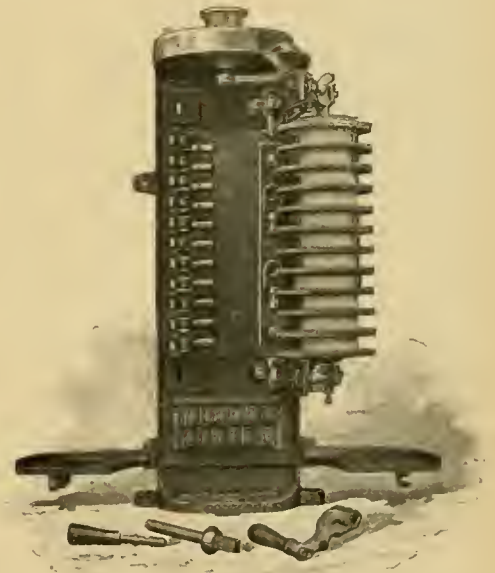

SERIES MULTIPLE CONTROLLER, OPEN.

market over three years without change, a remarkable record considering that the motor was at the time of its introduction the pioneer of enclosed street railway motors, and its designers had not the benefit of experience with this form of motor. The old Westinghouse No. 3 motors will continue to do good service on the roads where they are now running for many years to come, but the company now offers something still better, embodying the improvements previously mentioned as being common to the latest types.

The armature of the new machine differs but little from the old. It is a grooved drum, having lathe wound coils connected as a two-circuit winding. In this method of winding the active wire on the long sides of each coil is placed in armature slots 90 degrees apart, and the two ends of each coil connected to segments, 180 degrees apart. By this arrangement only two brushes are needed for a multipolar machine. Furthermore, as there are only two paths for the armature current, and one half of

all repairs can easily be made from the pit, and consequently the grease and dirt accompanying repair work is not introduced within the car. These motors are known as Numbers 10 and 12. Number 10 is made for 40 and 50-horse-power, and Number 12 for 20, 25 and 30-horse-power.

In connection with the new motor, an improved series-multiple controller is offered. In outward appearance and in movements of the handle it is the same as its predecessor, "type G."

The main improvement in construction is that of making the contact drum so that it can be swung back away from the contact tips. The case has a double back in which the wires and connections are concealed. The electrical combinations of the motors made by the new controller are improved over those of the earlier type, in that the motors divide the work equally, and the car starts more easily and attains its maximum speed more smoothly.

Among other things worthy of note in the Westinghouse car equipment are the Wurts non-arcing lightning arrester, which is entirely enclosed in an iron case and contains no moveable parts; and the fuse box with which it is impossible to touch live contacts while renewing a fuse.

The first road to use the new motors was the Terre Haute Street Railway, and President Russell B. Harrison says they have given satisfaction.

### KANSAS CITY CONSOLIDATION.

The consolidation of the Kansas City Cable Railway Company, the Grand Avenue Railway Company, and the Kansas City & Independence Rapid Transit Company, all of Kansas City, Mo., is the largest combination of the year. The name of the new company is the Kansas City Railway Company, and the combined capital stock is \$4,300,000. Immediately upon completion of the arrangements Walton H. Holmes was elected president; Victor H. Buck, vice-president; William B. Clarke, treasurer; D. B. Holmes, secretary, and Conway F. Holmes, general manager. Besides these,



CONWAY F. HOLMES,  
General Manager.

the board of directors will consist of W. A. Bunker, John Long, Hugh C. Ward, R. W. Hocker, G. W. Clawson, and L. C. Krauthon.

The man who engineered the plan of merging the lines was Robert Fleming, of London, England, who interested capital and originated the idea. Walton H. Holmes attended to the Kansas City part of the deal. Mr. Holmes acquired an option on the Kansas City Cable Railway from President William J. Smith at a good round figure, and surprised that gentleman by closing the option. This retires Mr. Smith from Kansas City street railways, in which he has been interested for many years. He is a man of great executive ability.

The new company has executed a \$5,000,000 blanket mortgage to the Central Trust Company, of New York. The total amount of the assumed obligations is \$4,980,000. The company now owns sixty miles of cable and electric, with valuable extension franchises.

Walton H. Holmes, the president of the new company, formerly president of the Grand Avenue Company, is 32 years of age. He, with his younger brother, Conway F. Holmes, succeeded to the interest of their father, Nehemiah Holmes, in the Grand avenue line, the pioneer line of the city. Conway F. Holmes, the present manager of the Consolidated, is a thorough street railway man, risen from the ranks of mule car drivers. He knows thoroughly every detail of the business, from oats to volts.

The Vose Spring Company, of New York, has moved its offices to 39 Cortlandt street.

### THE PRESENT UTILITY OF ELECTRIC MOTORS ON RAILROADS.

The above was the title of a paper recently read before the Western Railway Club, by David L. Barnes, of Chicago. Although rather elementary in its treatment of the subject of electrical apparatus, as was necessary in a paper read before steam railroad men, there were a number of points brought out that have not been extensively touched on before. Figure 1 shows the speed and acceleration of an elevated train in regular service, as taken by a Boyer speed recorder and presented in the above paper. Figure 2 was presented by the author as representing the amount of energy put into a train by the engine and taken out again by the brake shoes. The area, A, B, C, D, represents the energy put in by the locomotive, and C, E, F, the energy taken out by the brake shoes. The areas, a a and b b, show the small amount of power necessary to keep the train in motion continuously without starts and stops.

In comparing the cost of fuel for locomotive and electric motors, he says; "If the same fuel is used on the steam locomotive as in the stationary boilers, and the fuel is assumed to be fair bituminous coal, then each pound of fuel will evaporate into steam about about 6 pounds of water in the best steam locomotives, and 8½ pounds in a good stationary boiler. The steam locomotive will generate a horse-power for about 25 pounds of steam an hour when the locomotive is of the best type, hence, on this basis, a comparison of the economies of the two systems in the indicated horse-power in the steam cylinders of both systems is 1.8 pounds of coal per horse-power per hour in the stationary engines and 4.2 pounds of coal per horse-power for the steam locomotive. The steam locomotive uses the power directly and there is no further

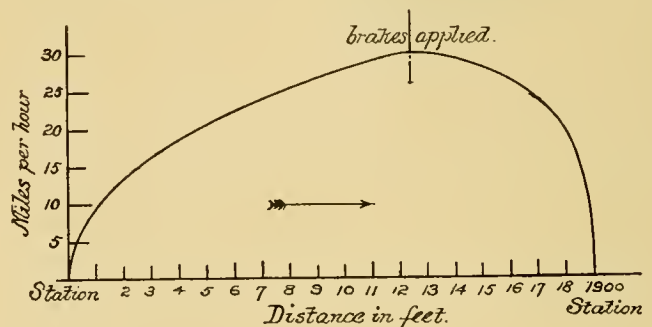

FIG. 1.

loss that need be considered with this general comparison, but with the electric system there is a further loss of 15 per cent in the dynamo and connections, 10 per cent in the line and 50 per cent in the motors for switching suburban and elevated work, or 20 per cent in the motors for lines having about eight minutes between stations. The final result is an efficiency of about 38 per cent between the cylinders of the stationary engine and the draw bars of the motors for switching elevated and suburban railroad work and 61 per cent for the longer line assumed. The result in the fuel used will then be

4.7 pounds of coal an hour in the stationary engine to get one useful horse-power on the draw bar of the electric motor for short lines, which is practically the same as that required for the steam locomotive. \* \* \*  
 If conditions are such that a cheaper class of fuel can be used in the central station than on the steam locomotive, there may be a considerable saving in cost of fuel while there is no saving in weight of fuel. On the elevated railroads of Chicago where the fuel costs about \$7 a ton on the tenders and the fuel for a central station could be purchased for \$1.75, a saving in cost of fuel of 63 per cent is possible. In this case allowance should be made for the difference in quality of fuel, which would reduce the possible saving to about 50 per cent."

The failure of the electric locomotive on the Manhattan Elevated, in New York, several years ago, has been brought up by the opponents of electricity every time the adoption of electricity has been discussed. Mr. Barnes clears the matter up and it is to be hoped that this trial

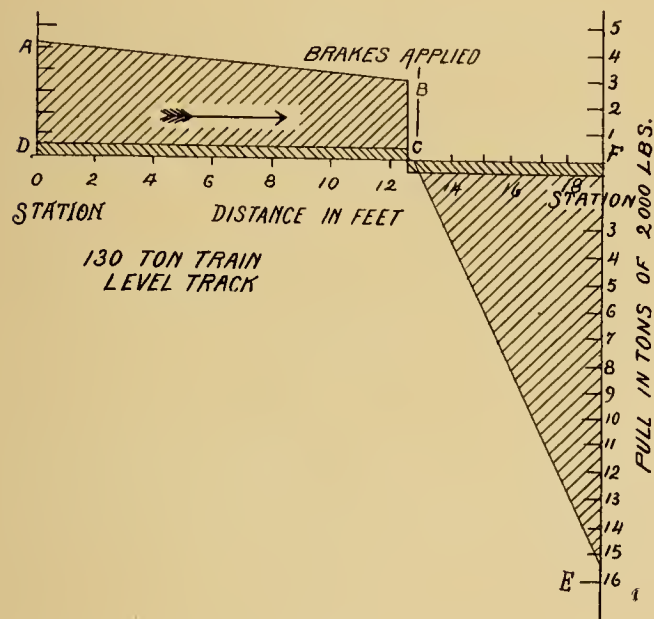

FIG. II.

will cease to be used as an argument. He says: "The first steam railroad of any importance to take up seriously an investigation of the plan to use electricity in place of steam was the Manhattan Elevated, in New York City. The motor (see Figure 3) was too small and not powerful enough, or at all adapted to compete with the steam locomotives then in use, and the design was also inefficient. The maximum draw bar pull was about 4,000 pounds. The failure was a certainty from the start, and although so evident at the time to those who were well informed in locomotive practice, yet this case of failure has been used unfairly ever since to show the impracticability of electric motors for railroad work. The trial was the result of a lack of appreciation of the real conditions, and to cite the results as showing anything useful, so far as power, cost or efficiency is concerned, is practically malicious."

The result of the tug of war at the World's Fair is thus commented on:

"The cause of the failure was a neglect to study conditions, and the results were so misleading as to need further mention here. The weight of this locomotive (the electric) on drivers is about 59,000 pounds. The weight of the steam locomotive, against which it was

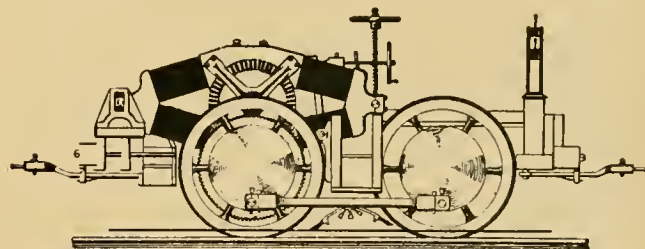

FIG. III.

tested, is about 62,000 pounds on drivers. The electric locomotive has a short wheel base, and the drawbar is above the center of the axle. When the pull came, the weight on one pair of wheels was reduced by the tipping tendency, and that pair slipped, and in slipping the motor on that axle revolved rapidly and acted like a dynamo, as has been before explained here, and shut most of the current off from the other pair of wheels, and the locomotive was practically without power. Had the motors been connected up so that the current divided and went through each separately, then the remaining motor on the other pair of wheels, after one had slipped, would have given a substantial pull but not enough to overcome the steam locomotive. If the wheels had been connected up with parallel rods the results would have been quite different, and if some heavy weights had been added to hold down the electric locomotive on the opposite end from the point of pulling, the electric locomotive would undoubtedly have pulled more than the steam locomotive,

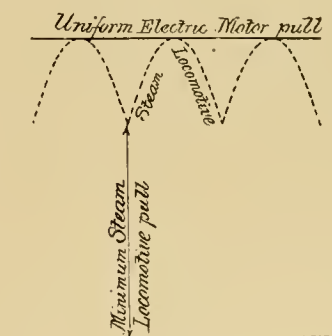
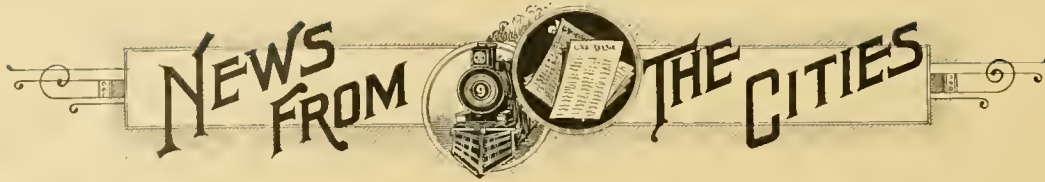

FIG. IV.

for the reason that the power of the electric motor is applied evenly, as shown by the full line in Figure 4, while the steam power is applied irregularly, as shown by the dotted lines."

CONEY'S army has been a drawing card at every large town where the commonweal has stopped. In one or two cases the street railway companies did a land office business in hauling the citizens to view the show.



### Alabama.

OPPELIKA, ALA.—John L. Cowan has about financed his Opelika-Auburn line.

### Arizona.

YUMA, ARIZ.—City council has granted Col. George A. Allen, franchise for electric light, telephone and water works systems. Will begin work immediately.

### Arkansas.

LITTLE ROCK, ARK.—The City Electric Railway has gained a 25-year franchise for a line to West End Park. Work will begin at once.

### California.

SAN DIEGO, CAL.—Electric Railway Company is granted franchise for extension on D street.

SAN DIEGO, CAL.—The electric railway will probably be extended out D street and operated with horses for a while.

SOUTH PASADENA, CAL.—The trustees have extended the electric railway franchise granted to the Los Angeles Consolidated. The road must be running by January next.

SAN FRANCISCO, CAL.—The California Street Cable Company has been granted its petition restraining the Ferries & Cliff House Company from discontinuing its steam car service making connections.

REDLANDS, CAL.—The Redlands Electric Light & Power Company expects to operate a street railway system by December. There will be seven miles of track, requiring 645 tons of rails and 275,000 feet of lumber, besides electric equipment. Bids are wanted for all supplies F. G. Ferraud, secretary.

LOS ANGELES, CAL.—Pasadena & Los Angeles Electric Railway Company is incorporated by P. M. Green, H. W. Magee, E. C. Webster, L. P. Hansen and Fritz E. Beach, of Pasadena; William Lacy and E. P. Clark, of Los Angeles. The capital stock is \$500,000, of which \$3,000 has been paid in. Road will be thirty miles long. Work has begun.

SAN FRANCISCO, CAL.—The Southern Pacific Railroad Company elects: President, Charles F. Crocker; vice-president, H. E. Huntington; second vice-president, J. E. Gates; treasurer, N. T. Smith; secretary, J. L. Willcutt; directors, Charles G. Lathrop and A. N. Towne, Mr. Lathrop succeeding Charles Mayne, who declined a reelection.

Geary street, Park and Ocean Railroad Company, President, Charles F. Crocker; vice-president, Adam Grant; treasurer, N. T. Smith; secretary, J. L. Willcutt.

### Canada

HULL, CANADA.—J. Viau wants to build an electric railway in Hull. Matter is before council.

QUEBEC, CAN.—M. Stephenson, formerly manager of the Upper Town Street Railway Company, died recently at Montreal, aged 57.

TORONTO, CAN.—The receipts of the Toronto Street Railway for March were \$72,850, an increase of \$372 over March of last year.

ST. JOHN, N. B., CANADA.—E. C. Jones, St. John, manager of the bank of Montreal, has bought the St. John street railway, which his company will electrify and extend.

HAMILTON, CAN.—After a hard fight the Hamilton Radial Electric Railway Company, has been incorporated at a large capital. It will inter-connect a number of surrounding towns. The steam roads opposed it.

### Chicago.

CHICAGO.—Commissioners of Public Works approve plans of the Northwestern L.

CHICAGO.—The North Chicago Street Railroad is building a one-story brick shop at 465 Sheffield avenue.

CHICAGO.—The West Chicago Street Railroad ran its first car around the Van Buren street loop, April 16.

CHICAGO.—Madison Maginn and H. Brandenburg are inventors of a new underground conduit system which, they claim, can be built for \$5,000 a mile.

CHICAGO.—Mr. Mason's bid of \$3,000 for the stock of the Railway Equipment Company was approved by the court. Terms some cash, rest on time.

CHICAGO.—Metropolitan L elects: Directors, John Worthy, R. P. H. Durkee, Robert E. Jenkins, John H. Glade, George Higginson, Jr.; President, John Worthy; Secretary and Treasurer, George Higginson, Jr.

CHICAGO.—The North and West Side trolley ordinance has been passed by the council, which accepts the mayor's amendments asking for more street lights. This gives Mr. Yerkes his wished for franchises on Lincoln and Milwaukee avenues.

CHICAGO.—The Englewood & Chicago Electric Railway Company will at first lease power but eventually build a plant of its own. The officers are: President W. H. Comstock; vice president, A. J. Whipple; secretary, F. E. Elder. The capital stock is \$1,000,000. William V. Jacobs, who built the Calumet system, was the promoter of the new enterprise. The franchise was granted last summer.

CHICAGO.—A deed of trust on first mortgage gold bonds for \$650,000 was filed to the Illinois Trust & Savings Bank by the Chicago North Shore Street Railway Company. The money will be used to build lines on the North Shore. The deed is signed by D. H. Louderback, president, and Howard Abel, secretary of the railway company, and W. H. Reid, third vice-president, and William H. Henkle, secretary of the Illinois Trust and Savings Bank.

### Colorado.

DENVER, COL.—The new Broadway bridge has been decided on, and it will be a handsome affair.

### Connecticut.

BRIDGEPORT, CONN.—The electric railway is to be extended to Ansonia. Work begun.

ANSONIA, CONN.—The electric railway applies for several extensions. It is a new and unexpected move.

NEW HAVEN, CONN.—A line of railway is to be built from Savin Rock to Merwin's point. It will be done by June 15 and cost \$30,000.

SOUTH NORWALK, CONN.—The South Norwalk-Winnepauk electric railway construction contract has been awarded to Milley & Pinney, of New York City.

LONGMEADOW, CONN.—The Enfield-Longmeadow Street Railway Company elects L. A. Upson, temporary treasurer, and George B. Fowler, temporary secretary.

NORWALK, CONN.—The Norwalk Horse Railway Company will change its name to Norwalk Street Railway Company. They will double track West avenue and electricity will be used on both their lines.



**NORWALK, CONN.**—The Norwalk Tramways elect Charles A. Johnson, of New York City, president, and George N. McKibben, vice-president. Richard H. Golden was elected a member of the board of directors.

It was voted that new stock be issued to the amount of \$60,000 to meet the expenses of the Roton Point extension.

## District of Columbia.

**WASHINGTON, D. C.**—A bill has passed extending time allowed the Metropolitan to put its wires underground. The original bill required the change in eight months.

**WASHINGTON, D. C.**—The Washington & Arlington Railroad Company's track, cars, leases and other property was sold April 14, for \$2,500, to C. S. Henchman, of Philadelphia. The power house was sold to H. P. Gilbert for \$1,000.

**WASHINGTON, D. C.**—A bill is introduced permitting construction of an elevated electric railway from Washington to New York. Introduced by Mr. Catchings, of Mississippi. The incorporators of the proposed railroad company are Messrs. Noah L. Jeffries, J. J. Reynolds, John J. Hemphill, S. M. Bryan, Hamilton Disston, A. M. Bliss, George R. Tingle, L. A. Grant, H. F. Welles, Moses Sweetzer, Hiram Woods, V. D. Stockbridge, C. F. Kindred, H. S. Reeside, J. D. Hetzell, H. C. Turnbull and George F. Brott.

## Florida.

**TAMPA, FLA.**—T. C. Taliaferro sole the Tampa Street Railway at auction, May 7. Receiver's sale.

**JACKSONVILLE, FLA.**—Geo. O. Holmes, John Clark and A. D. Stevens apply for charter for terminal railway to use electricity or steam.

**JACKSONVILLE, FLA.**—The Savannah Electrical Construction Company has received the contract for electrical equipment of the street railway here.

**OPLIKA, FLA.**—The street railway stock subscription book has been opened for the line between Opelika and Auburn. Leading citizens are interested.

## Georgia.

**AUGUSTA, GA.**—The Georgia Iron Works wants a 100-ton hydraulic wheel press, second hand preferred.

**SAVANNAH, GA.**—The Brush Electric Light & Power Company will enlarge its plant at a cost of \$50,000.

**ATLANTA, GA.**—The Atlanta Consolidated will increase its power three and a half times and buy more rolling stock. New lines are scheduled. The company will also build an extensive repair shop, and do some manufacturing.

**ATLANTA, GA.**—Atlanta Traction Company's new board of directors consists of E. B. Rosser, president of the Exchange Bank; W. G. Rosser, G. V. Gress, president of the Gress Lumber Company; W. C. Hall and Dayton Hall of the State Savings Bank; W. L. Seddon, southern manager of the American Employes' Liability Company; J. W. Hines, attorney; T. B. Felder, Jr., attorney. They elected the following officers: Dayton Hall, president; W. C. Hall, vice president; W. L. Seddon, secretary.

## Illinois.

**GALESBURG, ILL.**—The street railway will be extended this season to the new fair grounds.

**BELLEVILLE, ILL.**—Local capitalists buy \$30,000 in bonds of the Belleville Electric Railway.

**PEORIA, ILL.**—John C. White asks franchise for electric railway along Mt. Hawley road. Referred to committee.

**QUINCY, ILL.**—E. J. Stone, superintendent of the street railway, will buy paving brick at Danville for paving along the track.

**ROODHOUSE, ILL.**—Greene County Electric Company organized at \$30,000, by E. M. Prindle, Hamden Kelsey and J. A. Blanrock.

**FREEMPORT, ILL.**—The formal change of the street railway is made, and the R. S. Brown syndicate, of Easton, Pa., goes into power.

**STREATOR, ILL.**—C. C. Barr is appointed manager of the Streator Railway Company, with full authority to buy material and sign checks. C. D. Haggerty is made superintendent, under Manager Barr.

**ALTON, ILL.**—Warren H. Loss, of New York, E. R. Gilman and W. P. Williams, of Chicago, propose to combine railway and light interests in a \$125,000 plant, citizens to subscribe \$40,000 in stock. A new line is to be constructed at once.

**FREEMPORT, ILL.**—R. S. Brown, of Easton, Pa., has bought the street railway here, in behalf of a syndicate composed of himself, Congressman Haines, of New York, and Congressmen Mutchier and Sibley, of Pennsylvania. They propose an electric.

**DIXON, ILL.**—J. S. Ticknor and H. B. Andrews, of Rockford, F. J. Jones, of Oregon, and J. B. Bartelot, met here to listen to the report of Chft. Wise, of Chicago, on the probable cost, earnings and running expenses of the proposed Rockford and Dixon line. It was decided to build at once from Oregon to Dixon.

## Indiana.

**GAS CITY, IND.**—The Marion, Ind., Street Railway Company has been granted a franchise here.

**BRAZIL, IND.**—The Brazil Rapid Transit Company has applied for extensions to the Stough cemetery.

**INDIANAPOLIS, IND.**—County commissioners grant the Citizen's Company right-of way over Michigan street for extension.

**MUNCIE, IND.**—The Citizen's Street Railway Company is in the market for a high speed engine. General Manager, W. C. Gotschall.

**VALPARAISO, IND.**—Edwin Tice and Elzer S. Noe, of Chicago, have been granted a franchise for twenty-one years to erect and maintain arc and incandescent light plant and telephone system. Must be running in six months.

**MICHIGAN CITY, IND.**—The city council virtually renew the unexpired franchise of the Lake Cities Electric Railway Company. John G. McNutt, of Terre Haute and Frank Riddle, of Chicago, in conference arranged for one years' extension.

**NEW ALBANY, IND.**—John McCloud, of Louisville, Ky., receiver of the New Albany Street Railway, is authorized to issue \$30,000 in receivers certificates. The present liabilities of the company are \$150,000 first mortgage bonds, \$50,000 new bonds, \$30,000 common stock and \$3,000 in lesser debts.

**SOUTH BEND, IND.**—General Power & Quick Transit Company, incorporates at \$100,000 to build electric railway from South Bend to Mishawaka. J. McM. Smith, of South Bend, is heaviest holder. Andrew Anderson, W. G. Croybill, W. L. Kizer and J. DuShane, all of South Bend, hold one share each.

## Iowa.

**CLINTON, IA.**—The Joyce Park line will be equipped electrically.

**MT. PLEASANT, IA.**—An electric railway is on the tapis for this place. Local capitalists interested.

**TIPTON, IA.**—Organized: The Tipton Electric Light Company, at \$12,000, by W. N. Treichler, J. H. Coultts, C. A. Garrett, et al.

**SIoux CITY, IA.**—Philadelphia parties have bought the Sioux City Street Railway in interests of bondholders. Will reorganize at once.

**KEOKUK, IA.**—The Commonwealth Street Railway & Light Company has presented its ordinance for a twenty-five year franchise. Alderman Le Baron brings it before the council.

**KEOKUK, IA.**—The Gate City Electric Street Railway Company was sold April 28 to satisfy a \$85,000 mortgage held by the American Trust Company of Boston. J. C. Hubinger, of Keokuk, bought it for \$10,000.

MT. PLEASANT, IA.—The incorporators of the proposed Mt. Pleasant Electric Railway are: Dr. G. E. Smith, president; J. N. Ross, vice-president; and J. C. McCoid, secretary. All are representative citizens of Mt. Pleasant, and claim that they mean business.

### Kansas.

KANSAS CITY, KAN.—The Consolidated will electrify the dummy line and improve other portions of the system.

LEAVENWORTH, KAN.—William Dill, local attorney for the electric railway, applies for right of way to the Home and the Muncie cemetery.

SALINA, KAN.—The Salina Electric Railway Company has reached the district court. Phoenix Iron Works brings suit in replevin, presenting bill of \$5 500. Other liens and bills are to be presented also.

### Kentucky.

LOUISVILLE, KY.—The city council grants Ludlow street franchise to South Covington & Cincinnati.

COVINGTON, KY.—The council has granted the Ludlow street car ordinance, allowing rapid transit in the West End.

NEWPORT, KY.—Another electric line is to be built to the new Rose-dale race course. The promoters have laid out the line.

OWENSBORO, KY.—J. N. Alsop and W. E. Whiteley have bought the remaining stock of the Owensboro Street Railway. This harmonizes the management of the road as the men named control it.

### Louisiana.

NEW ORLEANS, LA.—The Electric Traction Company has been reorganized. Jas. H. Maury, formerly of New Orleans, is president, and H. M. Littell will still be general manager. H. B. Hollins & Co., Manuel Lehmann, Peabody & Co. and other New York capitalists back the enterprise with \$4,000,000, and the contemplated electricity and extensions will now go forward.

### Maine.

LEWISTON, ME.—The Lewiston & Auburn Street Railway Company will be allowed to change to the trolley by the city council.

### Maryland.

CATONSVILLE, MD.—President Perrin, of the Baltimore City & Suburban Street Railway, asks right of way for the Frederick turnpike.

BALTIMORE, MD.—Wm. A. Bosley, of the Chestertown interurban, says that prospects for the line are very bright. The interurban will connect a number of towns with Baltimore.

BALTIMORE, MD.—R. C. Davidson, Oliver Middendorf & Company, J. S. Gittings et. al. are considering plans for an electric railway along the Eastern shore. All are prominent citizens.

BALTIMORE, MD.—The incorporators of the Frederick and Middletown Electric Railroad have effected an organization and elected the following officers: President, G. W. Smith; vice-president, D. E. Kefauver; secretary, W. A. Sharets; treasurer, Hermon L. Routzahn; attorney, C. V. S. Lery.

BALTIMORE, MD.—The Baltimore, Canton & Point Breeze Railway Company asks for rights to lay track. Former rights having expired by limitation.

The City Passenger Railway will soon begin to build long extensions to Lauraville.

BALTIMORE, MD.—The Pikesville-Reistertown electric railway will probably be built. It is to be 10½ miles long, with power house at Owings' Mills. The company will issue \$250,000 5 per cent 40-year bonds. Henry A. Parr is president and Middendorf, Oliver & Co. financial agents.

BALTIMORE, MD.—The Legislature, having authorized city councils to pass fender ordinance, the committee of the Baltimore council has prepared ordinance requiring fenders and has appointed commission to recommend a fender. The approved fender must be adopted by all railways in the city.

### Massachusetts.

BOSTON, MASS.—Rapid Transit Commission favors the Meigs elevated system against the subway.

BOSTON, MASS.—The bill authorizing street railways to carry express has been reported upon favorably by committee.

SOMERVILLE, MASS.—Malden, Medford, & Stoneham Railway Company, has been granted authority to extend its line to this place.

BOSTON, MASS.—Lynn & Boston officials deny sensational reports of removal of General Manager Foster, Treasurer Williams and other officials.

BOSTON, MASS.—The special committee of the city council reports in favor of putting all feeders for the West End Street Railway Company under ground.

BOSTON, MASS.—The West End Street Railway Company will be compelled to put all feeders under ground. Telephone and telegraph companies must also bury wires. Time given until November 1.

ATHOL (Worcester County), MASS.—The Athol & Orange Street Railway Company is getting right of way and receiving bids. W. B. Ferguson, of Malden, and Sumner Myrick, of Boston, are at the head of the enterprise. L. B. Caswell will furnish specifications.

BOSTON, MASS.—N. Thayer, F. Bartlett, Arthur Hunnewell, et al., issue circulars calling for deposits of shares of the Kansas City Railway Company, and the Grand Avenue Cable Company, of Kansas City, Mo., for the purpose of fighting the consolidation of the lines.

### Michigan.

JACKSON, MICH.—The Francis street line will be extended to Vandercook's Lake.

MONROE, MICH.—The Toledo, Monroe & Detroit Electric Railway gets its franchises here.

DETROIT, MICH.—Mayor Pingree's erratic fancy has now taken to the conduit electric system.

BATTLE CREEK, MICH.—The street railway company has paid its employes in full—total sum \$800.

KALAMAZOO, MICH.—A scheme is on foot to transmit power here from the Buchanan water power plant.

DETROIT, MICH.—The Detroit Citizens Railway elects: D. M. Ferry, president; W. C. Colburn, vice-president; John R. Stirling, secretary; Geo. H. Russell, treasurer; J. D. Hawks, general manager; J. H. Fry, superintendent.

ADRIAN, MICH.—The Adrian street railway has suspended operations because the electric light company has shut off the current, claiming unpaid bill. The railway also owes its employes, and has a bonded debt of \$36,000. A receiver is talked of.

NEGAUNEE, MICH.—Negaunee & Ishpeming Street Railway & Electric Company elects officers as follows: President, Samuel Mitchell; vice-president, F. Braastad; secretary and treasurer, A. B. Miner. Following are the directors: Samuel Mitchell, F. Braastad, C. H. Hall, Alexander Maitland, Charles Merryweather, J. B. Maas and H. O. Young.

### Minnesota.

DULUTH, MINN.—Col. Harris is again before the city council asking for a franchise. Petition referred to committee.

STILLWATER, MINN.—May 7 the street railway will be sold at sheriff's sale. A local company is being organized to buy it. The line is bonded for \$60,000.

### Missouri.

ST. LOUIS, MO.—Report that the Peoples' Railway will consolidate with the Lindell is denied by President Green of the Peoples.

KANSAS CITY, MO.—The county court has granted franchise to the Westport & Waldo electric railway. Must be running within one year.

**KANSAS CITY, Mo.**—Minority stockholders of the Grand Avenue Street Railway are trying to break up the consolidation. They are Boston and New York men.

**ST. LOUIS, Mo.**—William Biddle and H. C. Frint, of the American Railway & Light Company, of New York City, are conferring with street railway men here in regard to a new system of electric railway.

**ST. LOUIS, Mo.**—"Work will begin in a week on the new power house of the Grand Avenue Electric Railway," says Secretary E. H. Comrades. D. C. Bartlett is in charge of the construction work of the line.

The St. Louis Car Company has increased its capital stock from \$150,000 to \$500,000.

## Nebraska.

**OMAHA, NEB.**—Sheriff levies on the cars of the Omaha Horse Railway Company to satisfy judgment for damages of \$5,000. The cars have been stopped. Temporary embarrassment only.

## New Hampshire.

**MANCHESTER, N. H.**—General Williams says that his street railway company intends to build the line here. Plans and specifications are being prepared by J. H. Bickford, of Salem, Mass., and others.

## New Jersey.

**NEWARK, N. J.**—The Consolidated Traction Company, has gained franchise to operate all city lines by electricity.

**NEWARK, N. J.**—The Consolidated has gained a franchise in Clinton township. Manager Young promises a first-class road.

**NEWARK, N. J.**—William Henderson of Bloomfield has been appointed superintendent of the Suburban Traction Company, vice J. C. Cotton, resigned.

**TRENTON, N. J.**—Incorporated, the New Jersey Traction Company, at \$150,000, by Jephtha H. Baldwin, of Orange; John H. Tingley, of Rahway, and George G. Crosby, of New York City. The following officers have been elected to control the company:—Frank A. Magowan, of Trenton, president; E. W. Hine, of Orange, vice-president; J. H. Baldwin, of Orange, secretary; J. H. Darrah, of Trenton, treasurer; George G. Crosby, of New York, John H. Tingley, of Rahway, and John C. McNaughton, of Philadelphia, directors. This is to carry out the plan of an interurban to Philadelphia. Right of way has practically been secured and construction will begin at an early date.

## New York.

**GENEVA, N. Y.**—The street railway will be running by May 15.

**SYRACUSE, N. Y.**—There is a scheme to build an electric line to Long Branch.

**ELMIRA, N. Y.**—The West Side Railway Company will build an extension.

**ITHACA, N. Y.**—The Ithaca Street Railway Company has been granted an extension.

**BUFFALO, N. Y.**—George Chambers, ex-police superintendent, has been appointed general manager of the Steinway, L. I., railway lines.

**MIDDLETOWN, N. Y.**—George Hess, of Scranton, Pa., has been appointed engineer of the power house of the M. & G. Electric Railway.

**MOHAWK, N. Y.**—The Mohawk & Ilion Street Railway is about to buy new cars. R. M. Devendorf, of New York City, is arranging the matter.

**LYONS, N. Y.**—O. F. Thomas, of the Manhattan Silver Plate Factory, is interested in a scheme to build a street railway from the village to the New York Central.

**NEW YORK CITY.**—Thomas Miller, formerly superintendent of motive power of the New York & Northern, is made master mechanic of the Metropolitan Traction Company.

**ITHACA, N. Y.**—The Cayuga Lake Electric Railway has elected Herman Bergholtz president and William Hand secretary and treasurer. The line will be operated June 1.

**BUFFALO, N. Y.**—Buffalo Woodworking Machine Company has furnished the Street Railway Company a complete repair shop outfit. The railway will build some of its own cars.

**BROOKLYN, N. Y.**—The annual meeting of the Brooklyn City & Newtown Railroad Company elected directors as follows: Louis Fitzgerald, Henry B. Hyde, John N. Partridge, John L. Heins, Thomas Ennis, Alfred Wagstaff and Edward L. Montgomery.

**SCHENECTADY, N. Y.**—The General Electric Company elected the following directors April 10: Oliver Ames, C. A. Coffin, T. Jefferson Coolidge, Jr., C. H. Coster, Thomas Edison, Eugene Griffin, E. S. Hastings, H. L. Higginson, D. O. Mills, J. Pierpont Morgan and H. McK. Twombly. Two more are to be elected and the annual meeting will be held May 8.

**NEW YORK CITY.**—On April 24 the Atlantic Avenue Railroad Company, of Brooklyn, elected the following directors: Newberry H. Frost, Benjamin F. Tracey, William J. Richardson, William F. Redmond, William H. Wallace, William A. Reed, Henry Seligman, John P. Hsley, Benjamin Norton, E. W. Clark, Jr., Silas B. Dutcher, William Mertens and Frederick Strauss.

**NEW YORK CITY.**—The subsidiary company of the Cataract Constructing Company, called the Erie Canal Traction Company, is organized at \$4,000,000 to furnish electric or other power for canal traffic. Among the directors are George C. Haven, 24 East Thirty-fifth street, New York; Thomas C. Platt, Owego, Tioga county, N. Y.; Adrian Iselin, 56 Wall street, New York; C. T. Lewis, 32 Nassau street, New York.

## North Carolina.

**RALEIGH, N. C.**—Raleigh Electric Railway Company sold for \$4,000 to Dr. J. H. McAden, of Charlotte, as trustee for several parties, including the general electric company. The buyers will re-equip and operate in connection with light plant.

## Ohio.

**FREMONT, O.**—The Electric Railway will be running in a week.

**LIMA, O.**—A. E. Townsend, of Pittsburg, is elected president of the Lima street railway.

**DAYTON, O.**—City Railway Company awards contract for new power house to O. L. Bouck of this city.

**NORWALK, O.**—The road to Fairfield is an assured thing. It will be an extension of the Sandusky, Milan & Huron.

**TOLEDO, O.**—Hon. John Kunler says the new Maumee line is progressing well, and that financial backing is all ready.

**ASHLAND, O.**—A line of electric railway is talked of from here to New London. H. A. Thomas, of Ashland, is the prime mover.

**YOUNGSTOWN, O.**—The Youngstown Street Railway Company has adopted the Ramsey-Smith signal system. D. E. Zinn, of Pittsburg, will install it.

**CINCINNATI, O.**—The legislature authorizes the city to condemn and buy right-of-way to Spring Grove Cemetery, two miles. This means extension for the Consolidated.

**COLUMBUS, O.**—Citizens of Rome, Alton, West Jefferson and other towns want electric railway line to Columbus. G. B. Holtsberry, of Columbus, says county commissioners favor the enterprise.

**MANSFIELD, O.**—S. N. Ford & Co. are making the bodies of some cars for which the Fulton Truck and Foundry Company will build trucks and the Card Electric Company, both of this place, add electric appliances.

**DAYTON, O.**—The Dayton-Cincinnati electric line men are named as follows: Directors—Judge Dwyer of Dayton, Attorney O. B. Brown, William A. Mays, secretary of the Ohio Paper Company; Frederick Reibald, president Teutonia National Bank; Oscar M. Gottschalk, attorney; William Huffman, Walter Smith, vice-president of the Smith-Vaile & Stillwell Bierce Co.

**TIFFIN, O.**—Meschek Frost, Amardus Betts and N. W. Miller have sold their stock in the Tiffin Consolidated Street Railway and will begin shortly the construction of an electric railway from Tiffin to Melmore. The Consolidated will elect officers to take the places of those retiring. Rollo W. Brown has bought the interest sold. President Brown will make some improvements and extensions. A general manager is to be elected.

### Pennsylvania.

**PITTSBURG, PA.**—The Pleasure Railway Company will build a pavilion and pleasure resort at Schenley Park.

**READING, PA.**—The Birdsboro Electric Railway Company wants a franchise here. It is to connect with the Pottstown road.

**HUMMELSTOWN, PA.**—Gettysburg Electric Railway Company elects: President, E. M. Hoffer; secretary, H. G. Walmer; treasurer, George P. Hoffer, all of Hummelstown.

**PHILADELPHIA, PA.**—The Thirteenth & Fifteenth Streets Passenger Railway Company ratified the issue of \$500,000 new bonds. The Traction Company has begun work on its power house.

**PITTSBURG, PA.**—Kensington Rapid Transit Company, of Pittsburg, is chartered at \$20,000 by Samuel E. Moore, Bernard Rafferty, Joseph P. Cappean, Curtis C. Hussey and G. Kaufman, of Pittsburg.

**HOUTZDALE, PA.**—Officers of the Houtzdale & Suburban are: President, A. Markle, Hazleton; directors, John A. Seely, Brooklyn, N. Y.; Charles A. Bragg, Philadelphia; E. S. Dond, J. Edwin Giles, Hazleton.

**CARBON (Lawrence County), PA.**—The Carbon Street Railway Company is incorporated at \$20,000 by James M. Bailey, Allegheny; John G. Robinson and Rawdon Evans, Pittsburg. To build two miles of line.

**ALLEGHENY, PA.**—The Etna & Glenshaw Electric Railway enterprise is headed by F. Gwinner, Jr., Edward W. Gwinner and William B. Rhodes, of Allegheny; Charles K. Hill, of Ross township, and William I. Mustin, of Pittsburg.

**BRADFORD, PA.**—The Bradford Electric Street Railway has gained its franchise. The new company is composed of Bradford people—L. Emery, Jr., C. P. Collins, F. D. Wood, T. N. Barnsdall, L. E. Hamsher, W. R. Weaver and C. C. Melvin.

**PITTSBURG, PA.**—J. M. Guffey, D. P. Reighard and W. B. Lupton have bought the rights and titles of the Mt. Washington Street Railway and intend to push the scheme to completion. It is said that they have plenty of money.

**LANCASTER, PA.**—Chartered: The Lancaster & Lilitz Electric Railway Company and the New Holland Railway Company. John S. Graybill, of Lancaster, is president of both, and the directors of both are J. S. Graybill, S. H. Reynolds, Dr. Henry Yeagley, C. F. Espenshade, et al.

At a meeting of the Lancaster & Philadelphia Electric Railway Company the following were elected board of directors: John S. Graybill, president; J. J. Patterson, Jr., Dr. L. Banks, W. S. North and Carl F. Espenshade.

### Rhode Island.

**WOONSOCKET, R. I.**—Curtis D. Shepard is made electrician of the street railway company by Superintendent H. M. Young.

**WOONSOCKET, R. I.**—The Woonsocket Street Railway Company elects: President, James P. Ray; secretary, Willard Kent; treasurer, Walter Whittlesey; superintendent, Herbert M. Young. Office of general manager was abolished. It was voted to apply for franchises for extensions in Cumberland, North Smithfield and Lincoln. Mr. Young succeeds Harry Ross as Superintendent.

**PROVIDENCE, R. I.**—The mortgagee's sale of the Attleboro, North Attleboro & Wrentham Street Railway took place May 10. The North Attleboro Steam & Electric Company, which was bought by the Interstate road, it is said, will furnish power for both lines. The property of the North Attleboro Steam & Electric Company was purchased by William H. Haskell, of Pawtucket, "for the bondholders." The principal bondholders are Mr. Haskell, Homer M. Daggett, Jr., president of the Interstate Railway Company; William A. Walton, of Providence, and T. P. I. Smith, of North Attleboro.

### South Dakota.

**HOT SPRINGS, S. D.**—J. M. Metcalf et al., of Omaha, Neb., gain franchise for electric railway in Hot Springs.

### Tennessee.

**NASHVILLE, TENN.**—The Citizens Rapid Transit Company, file amendment to charter asking extension. The incorporators are Charles Flisher, J. K. Spicer, W. E. Steger, Norman Farrell and E. L. More.

**NASHVILLE, TENN.**—Nathaniel Baxter, Jr., bought the United Railway, April 18, at receivers' sale. He represents the bond holders and paid \$138,500. There are \$1,516,000 in underlying bonds which are assumed by purchasers. Forty-six miles of road are operated.

**KNOXVILLE, TENN.**—Advices from Receiver J. C. Duncan, of the Knoxville Electric Railway Company, deny the report that he is about to be relieved of his duties. He says that the first mortgage bondholders are well pleased with his management, and that the road is in the best condition possible. He will remain until the mortgage is foreclosed by the court.

### Texas.

**DALLAS, TEX.**—Mr. Seibert, of St. Louis, is taking data for the equipment of the Oak Cliff Street Railway with electricity.

**DALLAS, TEX.**—Incorporated, the Dallas & Oak Cliff Electric Railway Company at \$200,000, by John N. Simpson, C. F. Carter, T. H. West, et al.

**FT. WORTH, TEX.**—The North Side Street Railway has been sold out as follows: Fifteen cars and equipments, to the Brownell Car Company, for \$5,000; electrical plant to the Thomson-Houston Company, at \$15,000; Thomas Worthington, of England, bought the track franchises, etc., for \$11,750. Liabilities of the road, \$300,000. Sale will be passed on by the judge in ten days.

### Vermont.

**BURLINGTON, VT.**—The electric railway people contemplate an extension to Queen City Park.

**BURLINGTON, VT.**—Burlington & Winooski Street Railway Company, increased capital \$150,000 and will build long extensions.

### Virginia.

**SUFFOLK, VA.**—G. W. Nurney has leased the Suffolk Street Railway and will resume operation of line which had been abandoned.

**ROANOKE, VA.**—The Roanoke Street Railway Company elects: President, S. W. Jamison; vice-president and treasurer, Joseph T. Engleby; secretary, George C. McCahan.

**PORTSMOUTH, VA.**—The Portsmouth Street Railway Company has elected officers as follows: Judge L. R. Watts, president; H. L. Page, vice-president; J. L. Watson, secretary; L. C. W. Page, superintendent. The company has bought the line and will buy new cars, horses, and lay new track.

### Washington.

**EVERETT, WASH.**—An electric railway franchise has been granted to A. H. Ganel.

### Wisconsin.

**PORT HURON, WIS.**—The City Electric Railway Company will build the Lapeer avenue line as soon as paving is finished.

**APPLETON, WIS.**—Mr. Maxwell, of Cleveland, O., representing Toledo capital, has been before the county board asking rights for a line from Neenah to Kaukauna.

**GREEN BAY, WIS.**—Incorporated: The Fox River Electric Railway Company, of Green Bay, to build in Green Bay, Ft. Howard and De Pere. Stock, \$100,000; incorporators, James H. Elmore, Adam Spahler and Frank A. Hollman.

**MILWAUKEE, WIS.**—It is stated that the management of the street railway has averted the strike by signing an agreement of wages at 19 cents an hour until May, '95.



THE Wright and Adams Company, Quincy, Ill., is building engines for electric work.

THE Johnson Company, of Johnstown, Pa., reports a good business from the Chicago office.

THE J. G. Brill Company, of Philadelphia, has removed its Western office to 1038 Monadnock Building.

THE Page Belting Company, of Concord, New Hampshire, suffered a severe loss by fire early in April.

THE American Car Company, St. Louis, was represented in the East by President Wm. Sutton, during April.

W. S. DAVIS & SONS, of Concord, N. H., meet with success in the marketing of their new design of tower wagon.

DAY'S Kerite, in the West, is persistently pushed by Cushing & Morse, 225 Dearborn street, with good results.

THE Dorner & Dutton Manufacturing Company, Cleveland, O., has taken several orders for trucks within the month.

L. K. HIRSCH, of Chicago, has bought the Pier movable sidewalk at the World's Fair grounds and will sell the wreckage.

THE Shultz Belting Company has secured commodious offices for its New York agent, A. B. Lawrence, at 113 Liberty street.

I. H. RANDALL, of Boston, has brought suit against the West End Street Railway for building and using his advertising rack.

THE Falls Rivet & Machine Company's western branch finds inquiries more numerous and prospects, as well as orders, good.

A. GROETZINGER & SONS, Allegheny, Pa., have taken several large southern and Western orders recently for dermaglutine pinions.

THE Stever Rail Joint Company, 407 Chamber of Commerce, is meeting with deserved success with its well-known rail joint.

THE Electric Car Supply Company, of 84-88 Mechanic street, Newark, N. J., makes a specialty of bearings and boxes for electric motor cars.

GEORGE B. MERRILL, corner of Washington and Clinton streets, reports that enquiries are numerous and trade as well as can be expected.

THE Brown Electric Company, Boston, has considerable railway business in sight and looks for a large increase in business very shortly.

THE Phenix Iron Works, Cleveland, are well stocked with orders which will carry them into July, and are now working both a day and night shift.

THE SIOUX CITY ENGINE & MACHINE WORKS has sold a 400-horse-power Corliss to L. M. Erb, for the Leavenworth Street Railway Company.

WELLS GOODHUE, well-known to Chicago electricians, has been appointed Chicago agent for the Wagner Electric Manufacturing Company of St. Louis.

THE McGuire Manufacturing Company, of Chicago, has closed a large number of truck contracts lately. New England business has been unusually brisk.

THE Eastern management of the Bass Foundry & Machine Works has been given to F. R. Baldwin, with offices at 39-41 Cortlandt street, New York City.

THE Laclede Car Company, St. Louis, through E. J. Robinson, has closed a contract for twenty-five cars, for the Consolidated Traction Company, of New Jersey.

H. R. KEITHLEY is distributing a neat paper weight, consisting of a section of rail web containing a "Chicago" rail bond, and showing plainly the perfect contact made.

THE Ames Register Company, Boston, makers of the well known Ames combined portable and stationary register, has closed a number of orders for this appliance.

SARGENT & LUNDY, 13 Monadnock Building, Chicago, report a new line of fans and motors of the Crocker-Wheeler pattern, and find a fair spring business in other lines.

THE Charles E. Gregory Company, of Chicago, has bought the entire stock of Carpenter heating apparatus and construction tools of the late Ansonia Electric Company.

B. W. PAYNE & SON, the well-known engine builders of Elmira, N. Y., have sold several engines lately for direct connection to General Electric incandescent light machines.

C. M. GIDDINGS, for many years in charge of the engineering department of Russell & Co., and well known as a designer and inventor, has returned to Ohio, and has sold to Brownell & Co. the exclusive right to manufacture under his patents. Mr. Giddings will have charge of the engineering department.

THE Chicago office of the Babcock & Wilcox Company finds reason for encouragement during these days and looks for a large amount of work in various lines of power using.

THE Hoppes Manufacturing Company, of Springfield, O., has the contract for supplying seven 300-horse-power purifiers to the municipal electric lighting plant, of Detroit, Mich.

THE Munson Belting Company, Chicago, is very busy. The present trade in saw-mill belting is unusually satisfactory, and Manager Groetzinger keeps things moving to ship orders on time.

THE Mosher Arc Lamp Company is in receipt of many new orders and a large number of inquiries. The St. Louis & Suburban Street Railway is one of the largest recent purchasers.

THE DAVIS CAR SHADE COMPANY, of Portland, Me., has received an order for 1,500 of the well-known Davis automatic shades from the Buffalo Street Railway Company of Buffalo, N. Y.



WOMAN'S LATEST VICTORY.  
To be seen any day on the Trolley Lines.

—Phila. Times.

C. C. PECK, of Rochester, N. Y., will equip the Detroit, Mich., Municipal Electric Light plant with the well-known Peck boiler. Seven boilers of 300-horse-power each are required.

THE Sunbeam Lamp Manufacturing Company, of Chicago, is now located in its new offices at Room 304, 100 Washington street. F. S. Terry is manager and his telephone is 1273, main.

THE JOHN STEPHENSON CAR COMPANY, of New York, is still keeping up its reputation as an exporter. Several recent orders from South America have been shipped since the cessation of hostilities.

THE Wallace Electric Company is now located in its new quarters, No. 307 Dearborn street, Chicago. A large stock of improved railway devices and standard electrical goods will be carried. With increased shipping facilities, the company is now in a position to attend to the wants of the trade without delay.

THE Phoenix Bridge Company, of Phoenixville, Pa., has been meeting with great success in marketing its steel street railway, light and telephone poles. The Chicago office is at 931 Rookery.

THE 2,000-horse-power Allis engine exhibited in machinery hall during the late World's Fair is doing duty in the Jersey City-Newark line power house of the Consolidated Traction Company.

ARTHUR PARTRIDGE, the well-known St. Louis supplyman, has sold the iron center pole equipment to be used on the Milwaukee and Lincoln avenue lines of the North Chicago Street Railroad Company.

WESTINGHOUSE, CHURCH, KERR & COMPANY have removed their Chicago office from the corner of Lake and LaSalle streets to the New York Life building, corner of LaSalle and Monroe streets.

THE NEW JERSEY ZINC & IRON COMPANY, of Newark, N. J., has placed an order for iron roofs, one 50 by 400, and the other 60 by 187 feet, with the Berlin Iron Bridge Company, of East Berlin Conn.

THE East India mica sold by A. O. Schoonmaker, of 158 William street, New York City, is meeting with a warm reception. It is sold in the solid sheet as it is mined and splits even with a smooth cleavage.

THE Schoen Brake Shoe Company has moved its western office from 1023 to 519 Monadnock Building, Chicago. Jas. T. Milner, the western agent, reports trade good with prospects of improvement.

THE HAMILTON CORLISS engines, made by Hooven, Owens & Rentschler, of Hamilton, O., have reached a high-water mark, and the record now reads, 1,000 in daily use and 150 in street railway service.

S. N. FORD & Co., Mansfield, O., made their first shipment of street cars of their own manufacture, last month. The cars were two in number, ready equipped for service on the Fremont, O., street railway tracks.

THE Stirling Boiler, has received the text of its award made to it at the World's Fair. The points awarded were, simplicity, low cost of construction, economy and adaptability to situations requiring impure feed water.

J. JONES & SONS, 39 Vesey street, New York City, are introducing Anti-Thunderbolt insulating paper, for resisting heat, oil, water, chemicals and gases. It is especially adapted for street railway generators and stationary motor armatures.

C. E. LOSS & Co., Pullman building, Chicago, have the contract for 5½ miles of construction and equipment for the Hammond, Whiting & East Chicago Street Railway. The reliability of this firm is well known, and the business will be completed on time.

THE Stanwood Manufacturing Company, Chicago, has been doing a good business in repair lines during the past month. A certificate is attached to each job sent out, so that the customer may know its requirements and capabilities.

THE new buyers of the United Electric Railway of Nashville, Tenn., have begun well. They have bought 18 new open cars from the Lewis & Fowler Car Company of Brooklyn, N. Y. They will be commissioned June 1.

THE International Register Company, 197 S. Canal street, Chicago, is doing a good business. A recent order equips the Toledo Consolidated Street Railway with International registers. The whole number will be 135.

BARTHOLEMEW, STOW & Co., have removed from 57 Michigan avenue, Chicago, to 19 North Clinton street, where the factory and store rooms are combined. Their lamp, the Nutting arc lamp, is meeting with great success.

THE Charles Munson Belting Company reports a decidedly better trade, orders being nearly up to the old time mark for the past few weeks. Seven large saw mills have been fully equipped with Munson belt within the last two weeks.

THE demand for the car lamp and headlight specialties of "Smith of New York" has become so great that Manager Charles G. Smith has been compelled to put on an extra force of men and work his factory day and night to supply the incoming orders.

A. L. IDE & SON, of Springfield, Ill., report a flourishing business, with a goodly number of orders from electric concerns. The new power transmitter is becoming very popular, and 24 engines, ranging from 8 by 10 to 12 by 20, have been sold within the month.

THE Manhattan General Construction Company, 50 Broadway, New York, and 753 Monadnock Building, Chicago, has taken the sales agency of the woven wire gauze dynamo brush invented by W. H. Fleming, late of the International Trading & Electric Company.

THE R. D. Nuttall Company, of Allegheny, Pa., will be represented in Philadelphia by Chas. J. Mayer, at the Betz building. Mr. Mayer will also represent the W. T. C. Macallan insulating material, and his long experience and genial personality are guarantees of his success.

THE Babcock & Wilcox Company, New York, has orders for a 1,500-horse-power plant for the Nassau Electric Railway, Brooklyn, N. Y.; a 1,500-horse-power plant for the Hestonville Passenger Street Railway, of Philadelphia, and a 2,675-horse-power plant for the Philadelphia Traction Company. The latter is a second order.

A. C. VOSBURGH, well-known to the trade as secretary of the New Process Rawhide Company of Syracuse, N. Y., has taken upon himself the duties of treasurer also. Mr. Vosburgh has a new process of his own which enables him to do the work of three ordinary men.

THE Westinghouse Electric & Manufacturing Company, through its southern agent, J. R. Gorden, has closed a contract with the Atlanta Consolidated Street Railway for two 400-horse-power generators, eight 30-horse-power motors, besides a 1,000-horse-power generator for the use of the new lines.

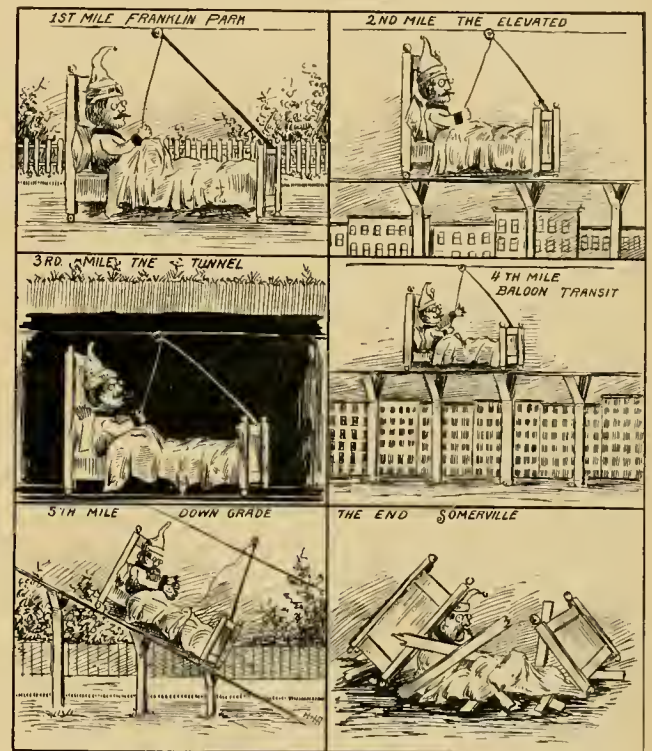

RAPID TRANSIT MATTHEW'S DREAM AND ITS RESULT.  
—Boston Beacon.

W. J. COOK, of the McGuire Manufacturing Company, Chicago, has closed orders for the Eastern trade as follows: Norwalk Tramway Company, Norwalk, Conn.; Norwalk Street Railway Company, Norwalk, Conn.; Taunton Street Railway Company, Taunton, Mass.; Dartmouth & Westport Street Railway Company, Newbedford, Mass.

THE Buffalo, N. Y. office of the General Electric Company, T. H. Fearey, manager, reports a large spring business. The Buffalo Street Railway Company has ordered two 800-kilowatt direct coupled generators, to be run on Lake Erie upright engines. Eighty-four equipments of G. E. 800 motors are also ordered. Besides these, many smaller orders are reported from the West Side road, of Elmira, the Kingston City Railway, the Buffalo & Williamsville, the Seneca & Waterloo, and the Grand View Beach Railway. The Buffalo & Kenmore Electric Railway will install two M. P. 100 generators.

THE Safety Brake Shoe Company, of Boston, Mass., received a deserved compliment from B. J. Weeks, of the Quincy & Boston Street Railway Company, recently, at a meeting of the Massachusetts Street Railway Association. Mr. Weeks said that the Safety Brake Shoes lasted from four to five months each, giving the best of service to the last turn.

THE Genett Air Brake is being adapted for use on the grip car, and a Third avenue, New York car is being fitted up for that purpose. Only one controlling valve is used at the dash, doing away with the brake and grip levers, and handling all with the small air valve. Only one additional brake cylinder is used, the pumps and receivers supplying both.

ON account of another large order from the Brooklyn City Railway Company, together with other demands from the New Jersey Consolidated Traction Company, the North Hudson County Railway, and numerous smaller calls, the Peckham Motor Truck & Wheel Company began May 1 to work a double force of men and to run the factory night and day.

THE organization of the White-Crosby Company results in the presidency of Mr. J. G. White, with Mr. Crosby as chief engineer. The arrangement is a perfect one as all concede who know the relative abilities of the two gentlemen. Mr. Crosby's magnificent engineering experience and Mr. White's equal ability will make the White-Crosby a great power in the electrical world.

THE Chicago rail bond, the invention of H. R. Keithley, of Chicago, and manufactured by the Washburn & Moen Manufacturing Company, is meeting with large sales. Among the largest roads in and about New York, Philadelphia, Chicago and other cities, the bond is being extensively used and everywhere with great success. Mr. Keithley and the manufacturers have every reason to expect an increased trade, although the present sales are eminently satisfactory.

THE question of a standard size for catalogues and similar publications is brought up periodically, but thus far the Street Railway Association has never taken any action in the matter. The committee appointed at the last meeting of the Master Car Builders' Association has reported on the following sizes as the most desirable: Postal card circulars,  $3\frac{3}{4}$  inches by  $6\frac{1}{8}$  inches; pamphlet and trade catalogues,  $3\frac{1}{2}$  inches by 6 inches, 6 inches by 9 inches, and 9 inches by 12 inches.

SHORT lap belting, of which the Charles Munson Belting Company has so much to say, and in which every belt user is so deeply interested, is the subject of another recent circular from this company. The circular says:

"When ordering belting, see that you get a pure oak tanned 4 ft. 2 in. lap belt (including the lap). If you do not get it, we claim you get the poorest kind of a belt,

at a high price in the end; any piece of leather in a belt, longer than 4 ft. 2 in. contains shoulder stock, and that is a poor grade of leather."

The Munson people will be glad to give further information on the subject and guarantee all their belting to be "short lap."

THE Economy Heat, Light & Power Company, of Scranton, Pa., has contracted with the American District Steam Company, of Lockport, N. Y., for the construction of a steam heating and power plant, with underground mains (Holly system), to cost \$150,000. The officers of the company are William Connell, president, and I. H. Burns, secretary. Central station heating will become a considerable factor in street railway economy as managers awake to the advantages of it.

THE Sioux City Engine & Iron Works, Sioux City, Iowa, has elected W. M. Thompson, president and manager, and E. H. Bucknam, secretary. The Pech. Manufacturing Company is consolidated with the old Sioux City Engine Works. All of the old engineering and constructing staff of the engine company, have been retained. Without doubt the new company with increased facilities will make an enviable record in the great West in this line of work. The capital is all paid in and the company begins with \$30,000 surplus.

THE Eureka Tempered Copper Company, of North East, Pa., has been enjoying a magnificent electrical trade in all departments of their extensive business. A new dry battery has recently been put on the market and called the "Eureka." Their brush holders for street car motors are also giving satisfaction, keeping an equal pressure at all times upon the carbon where it comes in contact with the commutator. The Eureka exhibit at the Columbian Exposition received an award of which the company is justly proud. The new woven wire brush is a successful device. The insulated wire trade is flourishing, and in fact the Eureka Company has nothing to complain of.

THE North Side Street Railway Company, which has extensive franchises along Lincoln avenue and other North Chicago streets, has let the following contracts for equipment: To the General Electric Company, twenty-five 25-horse-power G. E. 800 motors; to Brownell Car Company, twenty-five accelerator cars, mounted on Brownell trucks; to Siemens & Halske, of America, four 550 k. w. multipolar generators; to the Washburn-Moen Company, forty miles of bare wire, both trolley and bond; to the Johnson Company, twenty miles of 85-pound girder rail; the feed wire was sold by Arthur S. Partidge, of St. Louis, the well known head of the supply house of that name. This contract calls for thirty miles of wire, of which ten and a half miles are to be of 350,000 circular mils and the remainder of 250,000. The Garden City Construction Company will build the new lines, as D. H. Louderback says, in the highest style of the art.



STANLEY GREEN, the good natured western manager of the Fuel Economizer Company, at Matteawan, N. Y., dropped into the REVIEW office a few days ago, and upon being pressed, admitted his last trip was a fairly good one. This is the record: 300-horse-power to the Kingston, Ont., cotton mills; 1,000 to the Montreal cotton mills; 3,000 to the Montreal street railway; two 500's and a 300 to E. P. Allis for the sewerage plant, Boston. The Montreal order is a duplicate of the order given five months ago, and which takes water at 90° and delivers to the boiler at from 270 to 315 degrees. Recently, when the economizer was cut out of this service for three days for the first cleaning in five months, the fuel account was increased \$10 per day, which shows the record it is making in Montreal.

THE Metropolitan Electric Company, 186-188 Fifth avenue, Chicago, has now plenty of room, according to its strength, with two floors for storage, elegant offices and first class shipping facilities. A new department, under the care of W. F. Richardson, formerly of the Enterprise Electric Company, will be devoted to the street railway interests of the concern, and those who know Mr. Richardson's engaging personality and marked ability will feel assured of the success of any department under his charge. Already the company is prepared to supply the Gibbs trolley, the Hercules trolley clamp, the Knox circuit breaker, the famous P. & B. insulating products, and any number of miles of N. I. R. feeder wire. "The sales in all lines," said Secretary McKinlock, "have increased wonderfully since we have been in our new quarters."

## R. C. BROWN GOES TO MONTREAL.

R. C. Brown, electrical engineer of the West End Street Railway of Boston, has resigned that office to accept a similar position with the Montreal, Canada, Electric Railway.

Mr. Brown ever since 1889 has been in the West End's service, and by dint of effort and native ability raised himself to the position of electrical engineer. His first position of trust was as superintendent of motors and cars, quickly followed by the superintendency of electric power, which he has since held to the satisfaction both of the company and of his employes. The best wishes of his many friends follow Mr. Brown to his northern field, and a rousing ovation from 100 of his employes marked his departure.



R. C. BROWN.

E. A. BRADLEY, superintendent of the Waterbury, Conn., Traction Company, writes that his line will adopt electricity by July 1, using Sperry motors. A new inter-urban line to Naugatuck is now being built, and the street railway company will operate the electric light plant recently acquired.

## \$250 IN PRIZES.

This company, having the construction of a permanent plant in contemplation, invites outline drawings and general specifications of a model plant for the immediate use of twenty motor cars and twenty trail cars, with suitable construction to increase capacity to forty motor cars, as occasion may require. The lot will have a street frontage on the south of 450 feet, on the east an alley frontage of 550 feet, on the west a street frontage of 300 feet, on the north the diagonal frontage abuts a steam railway, from which a switch may be extended to any portion of the lot where convenience or economical operation may require. The street railway tracks may enter the lot at the northeast corner, and will also extend along the entire south frontage. Water can be extended from a city water main to any portion of the lot. The drawings must show the location of all necessary buildings, the position of Corliss engines, boilers, machinery, coal tracks, pits, and all other desirable features for a model plant. For the plan first selected \$100 will be paid, \$75 for the second, \$50 for the third, and \$25 for the fourth. The undersigned reserves the right to reject any and all plans, and shall be the sole judge of the merits of each. Said plans must be sent to the undersigned on or before the first of July, 1894. Each plan should be identified by the owner's mark, the name and address to be sent on separate paper.

Chicago General Street Railway Company, 1032 Lawndale avenue.  
C. L. BONNEY, vice-president.

## The Big Four Route Has the Best Terminal Facilities at Chicago.

All trains enter Chicago on the Illinois Central tracks along six miles of the Lake Front, through the most picturesque portion of the city, and land passengers in the magnificent new Central Station on Twelfth street and Lake Front. This station is convenient to the Auditorium, Richelieu, Victoria and Leland Hotels, and within two blocks of the State and Wabash street cable lines and the South Side Elevated Railway. Convenient stops are also made at Hyde Park, Thirtieth street and Twenty-second street stations.

Magnificent vestibuled trains, parlor cars, Wagner sleeping cars, private compartment buffet sleeping cars and superb dining cars. No transfer across Cincinnati to make connections.

Your ticket should read via the Big Four route to enjoy these privileges. E. O. McCormick, Passenger Traffic Manager; D. B. Martin, General Passenger and Ticket Agent, Big Four Route, Cincinnati, O.

THE C. & G. Cooper Western agency, under W. W. Nugent, reports business as good as can be expected during these times.

THOMAS H. McLEAN, general manager of the Citizens' Street Railway Company of Indianapolis, called upon the REVIEW recently.

THE HOPPE'S MANUFACTURING COMPANY, Springfield, Ohio, manufacturing the Hoppes Feed-Water Purifier, has received the contract for the purifiers to supply the boilers with pure feed water for the city electric light plant, now being built by the Public Lighting Commission of Detroit, Mich. After thorough investigation the Hoppes Purifiers were selected, and the order calls for seven 300-horse-power purifiers to carry 165 pounds of steam working pressure. Each purifier is required to heat and purify 9,000 pounds of boiler feed-water per hour.

## PERFORMANCE OF THE GLOBE STORAGE BATTERY IN CHICAGO.

It will be remembered that the December, 1893, issue of the REVIEW contained an account of the Globe Storage Battery which was about that time put on the line of the Chicago General Street Railway, for trial. Although lacking proper facilities for storing, the car has been in use a portion of the time since November 26, 1893. The following facts and figures are obtained from a report made to the company by W. F. Brennan, superintendent of the road. They give a good idea of the actual performance of the car.

During the period from November 26 to April 21, the car made a total mileage of 1,780. The longest run made on one charge was 65.5 miles. The car was out on forty different days, so that the average run was 44.5 miles. In storing, the average energy consumed was 40 amperes, at 110 volts or 4,400 watts. In the period before mentioned, 281 hours were spent in storing, which, at the above rate, would give 1,236,400 watt-hours as the amount of energy spent in charging. This makes the watt hours per car mile run 638.6. On the day of the 65.5 mile run, the speed averaged 8.2 miles an hour, the amperes 40, and the voltage 85. Although it is difficult to come to definite results as to the actual amount of energy recovered from the battery, an approximation can be made by calculating the total amount of energy recovered from readings taken during short periods on the car. A test made April 15, gave the amount of energy taken to run the car as an average of 3,400 watts during the time it was on the road, or 400 watt-hours per car mile. This gives an apparent efficiency of 62 per cent, since the energy put into the battery was seen to be 638.6 watt-hours per car mile. This figure is, however, deceiving, as the car test was made with a very good track, while much of the balance of the time the track was in bad condition, and several days the car was run in snow storms. This would bring the actual efficiency much higher. The small amount of energy taken to run the car is surprising, but is explained by the fact that no energy is lost in starting. The batteries are connected through a series-parallel controller to give 50 volts in starting, which is afterwards gradually raised to 180. On April 26, one of the cells was opened by Mr. Brennan, in the presence of Mr. Rogers, of the Sperry Electric Railway Company, and Mr. Conrad, of the Globe Storage Battery Company. It was found to be in fair shape. From the figures in Mr. Brennan's report, it would seem that the battery in question comes nearer to a successful solution of the railway storage battery problem than any heretofore offered. Meanwhile more exhaustive and extended trials will be awaited with interest.

THE Western Telephone Construction Company has just completed the installation of a 50-subscriber exchange at Albert Lea, Minn., for F. B. Forbes. It gives perfect satisfaction to both owner and subscribers.

## HERCULES TROLLEY CLAMP.

The two objections—and there are only two—to trolley clamps have always been: That they will not hold the trolley wire as well as a soldered ear, and that when they do have any strength they have to encircle the wire almost completely, thereby causing the trolley wheel to jump and consequently arc. With these two objections constantly in mind, the makers of the Hercules trolley clamp set to work to make a trolley clamp that could be guaranteed to have as strong a hold on the wire as a soldered ear and yet not enclose at any point of its entire length but little more than half the trolley wire. As the result of their labor they now offer the Hercules trolley clamp. It consists of but three pieces, two of which grip the wire, and the third, namely, the nut, holds the others in engagement and also fastens it to the insulator. As the threaded shank is all one piece, it is readily seen that once the nut is screwed down to bear on the loose piece,

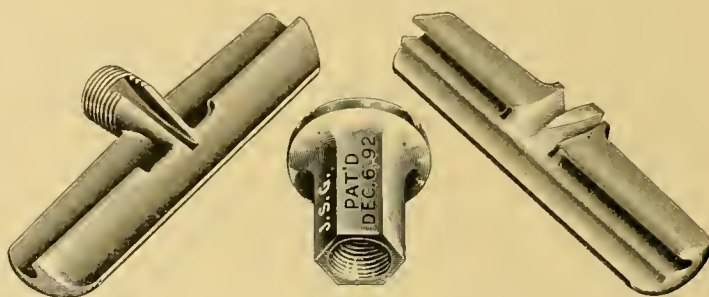

that the pressure on the nut is all on one side, which consequently locks the nut, and the clamp can not be jarred loose. When it is desired to adjust the clamp, it is not necessary to take the nut completely off, but simply unscrew it for three or four turns, when the clamp can be moved to the required point and refastened. A test was made recently by Robert W. Hunt & Co., of Chicago, on a Hercules trolley clamp and a 15-inch soldered ear. The Hercules clamp was subjected to a strain of 1000 pounds without being injured in any way whatsoever, while the soldered ear was distorted when subjected to a strain of only 500 pounds so that it could never be used again, and with an additional 180 pounds began to let go of the wire. In view of this test the makers of the Hercules clamp are certainly on the safe side when they guarantee their clamp to be as strong as a soldered ear. Gustin & Co., 84 Market street, Chicago, are at present making this clamp only for rigid hangers, but they are working on an attachment for flexible hangers, which will be ready very soon.

THE Chicago Electric Truck Company reports business very satisfactory. It is receiving many inquiries, and has placed one of its "B-2" trucks on the White Line, Dayton, Ohio, and also one under the new car of the Convertible Car Manufacturing Company, which is to operate on the Chicago City Railway. The company is now filling orders for their "A" trucks for the Jackson & Sharp Company, and the Fraser-Highland Company, for cars being built by them.

THE NEW GENETT AIR BRAKE.

The evolution of the Genett air brake, has so far been very similar to that of the electric railway motor. This evolution has been in the direction of compactness and complete inclosure, to secure protection from dirt and water. The new duplex pump placed directly on the axle has its moving parts entirely enclosed. As will be seen from the section of this pump here shown, the pistons consist of two pieces bolted together so as to form practically one solid piece and slotted both horizontally and vertically to receive the car axle and the eccentric which works the pump. The wearing parts are limited to

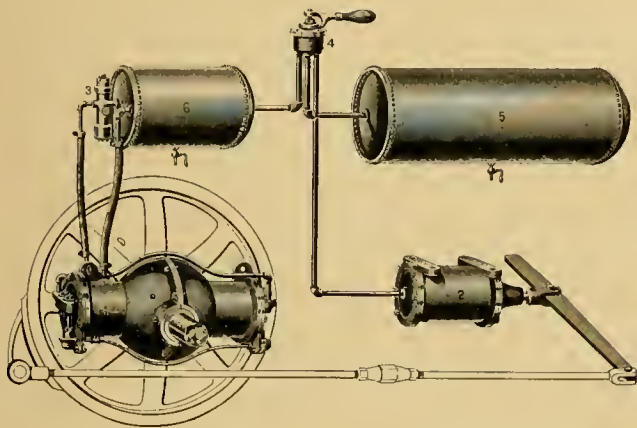

the eccentric plates and the bearings on the car axle. The space occupied on the axle by this device is only eight inches. It can be put on the same axle with nearly all the present makes of motors, though it is necessary sometimes to move the motor a little to one side or the other. The pump is oiled in the same way as a gear case by keeping it partly filled with oil.

An explanation of the principle of the Genett brake will be of interest to those who have not looked into the matter. The apparatus and piping required on a car can be seen by a glance at the engraving. In applying the brakes, air is admitted from the main reservoir 5, into the brake cylinder, and connection with the auxiliary reservoir 6, is closed. The regular running position of the brake handle opens the passage between the main and auxiliary reservoirs. The action of the pump is governed by the pressure in the auxiliary reservoir. When the pressure in it falls below thirty pounds, the pump begins to discharge into it. Normally the pump discharges into the open air against no resistance. When the motorman releases the brakes, he puts the handles on what is called the "starting point." This releases the air from the brake cylinder and closes the passages to both the reservoirs. After the car is under way, the handle is turned to the "off" position which opens a way between the reservoirs. The object of this is to prevent throwing the pump into action when the car is starting. Keeping the auxiliary reservoir pressure constant, by closing it when the air is drawn from the main reservoir to apply the brakes, prevents the pump from working until after the car starts, the pressure in the auxiliary is

reduced to make up the lost pressure in the main reservoir. Pressure is reduced three pounds by one application and should the pump fail to work, there is enough in the reservoirs for ten applications. A peculiarity of the controlling handle of this brake is that the "emergency stop" position is between the "service" and "off" positions. The idea of the makers is that the ordinary motor-

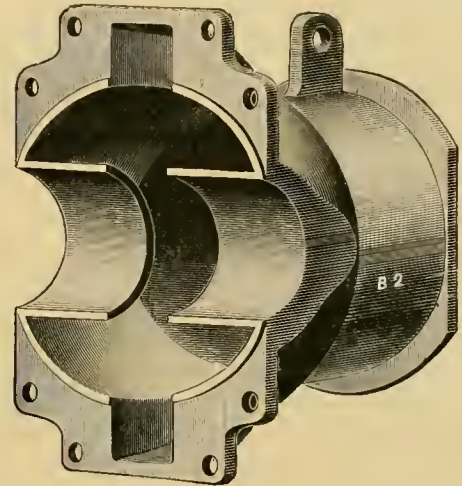

man will throw the handle to its extreme position in spite of all regulations, and that it is better to have the service stop there than to have the motorman using the emergency for service stops. The force of brake application is governed by the rapidity with which the handle is brought past the emergency point, as this is the point at which air is admitted to the brake cylinder. The Genett apparatus is made for hard practical service and the company proposes to do its work well or not at all.

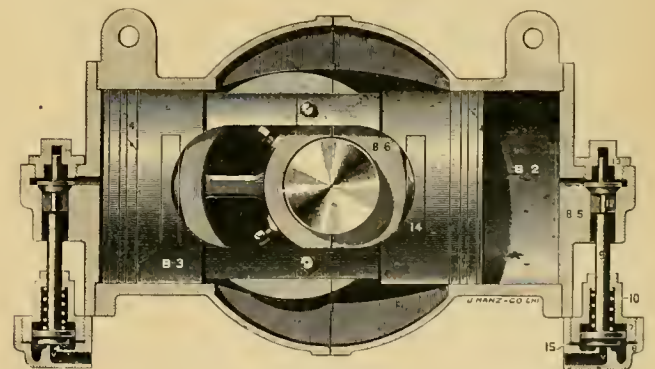

On the roads now using the air brake it is giving an efficiency fully equal to that furnished by the air system on steam roads, and for high speeds is quite as essential; while on lines operating at low speeds, its prompt action and easy control make it in every way desirable. The eastern office is at 33 Wall street, New York city, while the works and western department are at 11 to 23 South Jefferson street, Chicago.

A NUMBER of Toronto, Canada, young men recently became so "funny" that they took down a stake and rider fence, and built it up again across the tracks of the Toronto & Scarboro Street Railway.

## PERSONALS.

W. H. BRENNER has resigned the electrical engineering of the Montreal, Canada, Street Railway Company.

E. P. ROBERTS, president of the Cleveland Correspondence School of Technology, was a visitor in Chicago recently.

J. W. COOPER, treasurer of the J. W. Fowler Car Company, has resigned, and F. L. Heidritter succeeds to his position.

D. H. GOODRICH, the long-headed secretary of the Omaha Street Railway, was a most welcome visitor at the REVIEW office.

F. A. MORRELL, of the Lewis & Fowler Manufacturing Company, of Brooklyn, N. Y., was an April visitor at the REVIEW office.

A. W. FIELD came into Chicago from the Boston office of the Peckham Motor Truck & Wheel Company to spend a few early May days in business.

PROFESSOR SIDNEY H. SHORT and Vice-President Billing, of the Walker Manufacturing Company, Cleveland, spent some days lately in Chicago.

FRANK DE HAAS ROBINSON, of Cleveland, will be pitted against his brother street railway magnate, Tom L. Johnson, for congressional honors at the next election.

ALEX. LEWIS, well-known as the Western manager of the Curtis Electric Company, has resigned, to locate in Cincinnati, O., where he will handle electric railway supplies.

ON April 25, Michael F. Burke, superintendent of the Terre Haute Street Railway Company, was married to Miss Margaret M. Toner, of Terre Haute, by the Rev. Father Schnell, at St. Patrick's Church. Two sons of the groom and two nephews of the bride were the acolytes.

J. R. CHAPMAN, general manager of the Grand Rapids Electric Railway, Grand Rapids, Mich., has been engaged by Mr. Yerkes as manager of the proposed and constructing lines of electric on the North and West sides, Chicago. The duty is well placed, as Mr. Chapman is a competent manager as well as a first-class electrician.

FRANK C. PECK, has resigned from the Kansas City Cable Railway, where he has so ably filled the office of Assistant General Manager, and will engage in commercial business on his own account. Mr. Peck has had 14 years constant service under President Smith, and is one of the most practical and best informed railway men in the fraternity. We join with his numerous friends in the wish and expectation that he will achieve the same deserved success in his new venture, as has characterized his street railway experience. Thomas Barrett, succeeds Mr. Peck under Manager Holmes.

## THE ELLIS CAR COMPANY PLANT BURNS.

On April 26, the plant of the Ellis Car Company, at Amesbury, Mass., was totally destroyed by fire. The building was a two story frame, built six years ago by W. G. Ellis. The loss was \$50,000 and the insurance \$16,000. Besides the work under way, twenty-five finished cars and \$10,000 worth of wagons were lost. The fire is supposed to have originated in the paint shop.

## ST. PAUL PARK—A NEW PICNIC GROUND.

St. Paul Park is located at Morton, Ill., fourteen miles north of Chicago, on the Chicago, Milwaukee & St. Paul Railway. The grounds cover eighty acres on the North Branch River. One-half is a grove of large maples, the other half is a level meadow suited for baseball, tennis and all outdoor games, good boating on river, and in every way most attractive picnic ground in the vicinity of Chicago.

For further information, rates, etc., apply to H. E. Laing, City Passenger Agent, Chicago, Milwaukee & St. Paul Railway, 207 Clark street.

## OBITUARY.

BIRDSIL HOLLY, the inventor of the Holly waterworks system and the Holly district steam-heating system, died recently at the age of 72. He was an engineer of prominence, known both in Europe and America. His home was at Lockport, N. Y.

GEN. HENRY W. SLOCUM, president of the Brooklyn & Coney Island Railroad Company, died April 14, at the age of 66. His road was the first of the Brooklyn lines to adopt electricity.

## NEW PUBLICATIONS.

THE VULCANIZED FIBER COMPANY are sending out a neat little book giving uses, prices, and manufactured forms of vulcanized fiber.

"THE ECHO" is the name of a new paper about to be published weekly in the interests of the employes of the West End Street Railway system, of Boston. As there are over 5,000 employes, there would seem to be plenty of field for such a paper. It will embrace the whole range of matters of interest to the employes.

THE first number of "The Trade Press," the handsome monthly issued by H. J. Bohn, and devoted to the interests of publishers of technical and class papers, reflects much credit on its maker. It is neat, concise, full of suggestive ideas, and most welcome in every way. It is absolutely alone in its field, and proposes to wage ceaseless war on the house organ.

THE May 1 issue of the Pharmaceutical Era is called its moving day number, and celebrates the removal of that paper from Detroit to New York. It is a very elaborate issue, and the publication is a credit to its publishers. It contains an immense amount of information valuable to its trade.

R. C. CRAWFORD, formerly secretary of the West Chicago Street Railroad Company, has entered stock broking, with elegant offices on the first floor of the Stock Exchange building, Chicago.



WINDSOR & KENFIELD,

PUBLISHERS AND PROPRIETORS,

269 DEARBORN ST., - - - CHICAGO.

Published on the 15th of each month.

SUBSCRIPTION, - - - TWO DOLLARS.

FOREIGN SUBSCRIPTION, - - - 20 SHILLINGS.

Address all Communications and Remittances to THE STREET RAILWAY REVIEW,  
269 Dearborn Street, Chicago.

H. H. WINDSOR,  
Editor.

F. S. KENFIELD,  
Business Manager.

**CORRESPONDENCE.**

We cordially invite correspondence on all subjects of interest to those engaged in any branch of Street Railway work, and will gratefully appreciate any marked copies of papers or news items our street railway friends may send us, pertaining either to companies or officers. Address:

THE STREET RAILWAY REVIEW,  
269 Dearborn Street, Chicago.

Eastern Office, Room 14, No. 128 Liberty Street, New York.

This paper member Chicago Publishers' Association.

Entered at the Post Office at Chicago as Second Class Matter.

VOL. 4.

JUNE 15, 1894.

NO. 6.

**Contributions.**—*Subscribers and others will materially assist us in making our news accurate and complete if they will send us early information of events which take place under their observation, such as changes in railroad officers, organizations and changes of companies in their management, particulars as to the business of the letting, progress and completion of contracts for new work or important improvements, experiments in construction and operation, and suggestions as to improvement. Discussions of subjects pertaining to ALL DEPARTMENTS of street railway business, by men practically acquainted with them, are especially desired. Officers will oblige us by forwarding early copies of notices of meetings, elections, appointments, and especially annual reports, some notice, of all of which will be published.*

THE Michigan Street Railway Association was organized at Grand Rapids on June 5, and adds one more strong association to the growing children of the paternal American association.

THE trolley is every day becoming more popular in Brooklyn, and as predicted in these columns, has proved a fast increasing competitor to the L lines. Another reduction in wages has just been made, and the reason ascribed is the loss of business, owing to the surface lines capturing the travel.

A BOSTON lawyer, Charles S. Rackman, thought he knew the law and refused to pay fare on a street car where no seat was furnished him. He was ejected and sued for his passage and ejection. He lost his case and the company received a verdict of the amount of the fare and two cents damages.

MAYOR SCHIEREN, of Brooklyn, proposes to call a meeting of trolley line presidents and managers, with a view to arranging a reduced schedule of speeds. We still hold to our former conviction that no manager is likely to permit a time table to continue which calls for a running time dangerous to the public, and that it is impracticable to make an inflexible rule.

THE Supreme Court of Pennsylvania has ruled that a company is guilty of contributory negligence, if, when in the exercise of ordinary prudence the conductor or driver of an electric car saw, or ought to have seen, a horse or team frightened by the movement of the car, and fails to slacken its speed or bring it to a stop. If the driver of a vehicle is placed in a state of peril by the negligence of those having charge of a car, the company is responsible for the consequences.

THE decline in iron and steel prices since January, 1893, has been from 26 to 10 per cent, according to the shape the material is in. A greater part of this fall has occurred since January, 1894. The fall of prices after the panic of 1873 was gradual as compared to this. Previous to 1893, prices had been steadily declining and it was thought the low water mark was reached, but with the panic came a reduction in every item of the cost of manufacture, and prices have gone down far below what was formerly the cost of production.

THAT a street railway has not only the right to make reasonable rules for the safe and convenient care of its passengers, but as well to enforce such regulations, is again plainly set forth in the ruling of the Appellate Court of this state. A passenger on the Ft. Clark road, in Peoria, persisted in standing on the rear platform when there was room inside the car. He allowed himself to be ejected without force, and in the lower court secured ninety dollars in damages. This was reversed in the Appellate, the court holding that "a street car company has the right to require a passenger to observe all reasonable rules tending to promote the safety and convenience of passengers, and the successful conduct of its business. So long as a passenger observes such rules the company is bound to carry him, but when he wantonly refuses to obey them, the company has the right at once to expel him, using no more force than may be necessary for that purpose."

THE Dodge bill giving electric railway companies the right of eminent domain has become a law in Ohio. It allows them to use the public highways in the country, and streets and alleys in villages and hamlets, with the consent of the public authorities in charge of the streets and with the consent of a majority, measured by the foot front, of the owners of property abutting on streets on the entire route. These companies are given the same powers to appropriate private property as is had by railroad companies. There is a suspicion that this bill means more than appears on the surface, particularly as these companies are given the right to consolidate

with street railroad companies. It is questioned whether the law will not be retroactive and allow steam lines to use city streets. Under the conditions of steam locomotion now in vogue it is doubtful if this will be the case, however, as the city steam road has long since been declared a public nuisance.

THE question of the proper temperature for open car service has again come up in Brooklyn, and a schedule agreed upon. Under 65 degrees the proportion of open to closed on the street decreases to none at all for cold weather. With the changeable climate of the Northern tier of states, particularly those along the great lakes, it is an extremely difficult matter to anticipate the proper car. In Chicago it is no infrequent thing during the hot weather in summer to have a sudden change in the wind cause a drop of twenty and even forty degrees in five or ten minutes; in which case it would be obviously impossible to call in several hundred opens, scattered out on 150 or 200 miles of track, and replace them with box cars. It is a task requiring several hours to run in one equipment and replace it with the other. Companies should do all in their power within reason to comfortably and suitably take care of their patrons, but unfortunately they cannot make the weather, and to put out box cars on a hot day is to invite a storm of popular wrath.

WE are still thinking of the future of the interurban—the link that is to bind the country to the city with a sort of electric weld, and make suburban life of isolated existences. A great deal is said these days about the overplus of city population, where a large proportion of able bodied men can only secure occasional work; and of the millions of broad, rich acres, patiently waiting for the touch of the husbandman.

The soil lies fallow, the woods grow rank,  
Yet idle the poor man stands;  
Oh, millions of hands want acres,  
And millions of acres want hands.

The great tide has for ten years surged toward the city, but it is doubtful if the ebb will carry many back. Unquestionably the individual and the nation would be infinitely better off if a few millions of city dwellers could be induced to take up farming. In Europe, a few acres, which would hardly make a respectable garden here, are sufficient to comfortably support large families. The construction of country electric lines will bring into the provision market the product of thousands of acres now devoted to general farming, and create new occupations. It is bound to come.

ON one of the surface lines in Brooklyn, a passenger was killed by striking a telegraph pole, as he was walking along the footboard of an open car while changing seats. It was one of those unfortunate cases, which, however much to be regretted, cannot be blamed upon the crew. However, the police promptly arrested both conductor and driver, who were taken to the station. As it was late Saturday night, no little difficulty was

experienced in sending for the railway officials and furnishing bail. The men were meanwhile held at the station and booked under a charge of homicide. No one on the car, or even the station officers, claimed the arrested men were in any manner to blame for the accident, but nevertheless the charge was entered, and the men treated accordingly. What was really wanted was to insure their presence at a coroner's jury as witnesses, and the injustice is apparent of resorting to such extreme measures to secure the desired result. Of all men, the driver and conductor of a street car can be readily located, as the starter's record always shows who are on every car, and the car number is usually painted in large plain figures, in from four to six places on each car. The same practice generally prevails in all large cities, and we submit it is unreasonable and unnecessary, and inflicts a wholly needless burden and to a certain extent ignominy on the men.

THE report of electrical fires in the United States during the first quarter of 1894, as made by W. H. Merrill, Jr., electrician of the Chicago Fire Underwriters' Association, does not show a very alarming percentage caused by the existence of a large trolley wire mileage. The report covers all the larger cities, so that it is safe to say that it includes all the fires caused by trolley wires, although it does not include all the fires caused by electricity. In considering the following figures it must be remembered that the number of electrical fires is considerably less than 1 per cent of the total number of fires. Out of the eighty-two electrical fires reported during the quarter mentioned, five were caused by the existence of the trolley wire in the streets. With one exception, these were the result of crosses between telegraph or telephone wires and the trolley. The losses were nominal, except in the case of a telephone exchange switchboard. This latter loss would have been avoided had proper fuse blocks been used on the telephone circuits. In fact, the failure of the telephone and telegraph companies appears to have been at the bottom of the three other smaller fires. Two very heavy losses, which were caused by defective wiring in poorly constructed and oil soaked car barns, should not be classed as fires caused by the trolley. They make the total number of fires from railway circuits seven. With but twenty to thirty fires a year in the United States caused by railway circuits, and the majority of them avoidable by insurance inspection, the outlook is certainly not very alarming.

IN many matters street railways have been guided by what has found to be good practice in steam road-ing. In the question of welded joints the street car people are taking the lead. On this point we might mention the fact that the welding on the Baden & St. Louis electric line, St. Louis, is astonishing doubtful managers at its strength and evenness. One president tells us he visited the work, and taking a heavy sledge pounded away on the "joint" as hard as he could. The result was a pair of lame arms next day, while the

welded joint remained unharmed. The tread of the rail is also smooth and shows no line of contact. The inclination toward rails of unusual lengths on steam roads shows the tendency toward a reduced number of joints. The Norfolk & Western has used 60-foot rails over a year and is now laying this length, paying a premium of two dollars per ton. This extra cost, however, they consider balanced by the saving in cost of joints. On one section tested a range of 125° temperature between winter and summer showed no difficulties in bulging or creeping. The Pennsylvania road has laid considerable 33-foot lengths; and it is understood that the report of the committee of the General Managers Association of this city will recommend that if any increase in length is made it be to 60 feet. Of course, what is good practice for steam roads is not necessarily such on electric and cable lines, but on the question of rails and joints the two sit together on a front seat on the mourner's bench.

A SHORT strike was made by the conductors and motormen of the Atlantic Avenue road, Brooklyn, and for what would appear to be a most insignificant and ridiculous issue. The company decided that its motormen should wear gray blouses this summer, instead of blue, which was the established color last year. The garments cost \$5.50 each, and last an entire season. That they do last the season is self evident, from the fact that one of the chief claims made by the men was that the blouses worn a year ago were still in good condition. The strike reflects no credit on either the good judgment or loyalty of the men. Not one of the strikers but lost more in wages than would have paid for the new garment, and few people who are at all familiar with the severe wear of clothes incident to car work, or who recognize the reasonableness of companies expecting their men to appear in suitable and uniform apparel, will question the wisdom of the company. Street car employes are well paid for the class of work performed and the short time necessary in which to become competent workmen, and it is eminently just and fair that they should appear neat and trim, especially as the arrangements made by the roads enable their men to secure the suits at a wholesale price, far below what the men, as individuals, could possibly purchase at. In Chicago, the garments are all made to order from individual measurement in each case, and of good and lasting materials, and are furnished the men at from \$12 to \$15 less per suit than they could duplicate the same garments anywhere but at the uniform tailor. The same is true in other cities. Again, we say, we consider the Brooklyn strike unbecoming the Atlantic Avenue men, as exhibiting poor judgment and lack of reason.

AND now it is the "deadly trolley" sure enough. For six years the trolley has gone up and down the streets and avenues, and stalked abroad in the land. It has carried in safety millions of people, young and old, the blind, the halt—even deadheads have been found among its living freight—and all this time it has been "the deadly trolley," according to the daily press. At first, blood-curdling

reports swarmed out of dangers *futurus esse*. These were followed by still more glaring recitals of horrors which would have made the Inquisition green with envy. It has been the province of the REVIEW to run down these reports, and in every case they were found to be false in whole or part, and never once has there been a bona fide case of death as a direct result of the 500-volt railway current. But now we find a case, and with the same fearless and unbiased investigation the REVIEW lays the particulars before its readers. The railway current has finally found a victim. Five long years, in 400 towns and cities, it has searched through storm and shine, in densely crowded business streets and along retired and shaded residence avenues, and always returned empty-handed. But now its perseverance is rewarded, and it can claim its first life. But what the circumstances? A young boy, who had worked in an electrical shop and gained a smattering of electrical knowledge, conceives the idea of "getting a shock." He takes a long piece of wire, one end he tightly winds about his left arm, making a dozen or more wraps. He then throws the other end over the trolley wire and seizes the end in his right hand. But no shock. He then winds the free end about his right hand, tightly and several times. And still the lightning refuses to be coaxed from its hiding place. Failing to receive any shock while standing on the pavement, the boy purposely walks to the rail and places his foot upon it. Then, and only then, is there any shock. He is stunned and falls across the rail, and the frightened children watching the event make no effort to remove him. When adult help arrives after several minutes, life is extinct, and the "deadly trolley" is at last vindicated. The unfortunate occurrence, however, is striking evidence of the fact that a case of this kind is practically impossible in the everyday walk of life, and as an exception proves the rule that the 500-volt railway current is not dangerous. Of course if people desire to electrocute themselves, as in this case, it can be done. So can people lie down and permit a street sprinkler, or a wagon loaded with several tons of iron, to pass over their prostrate bodies. An ordinary hat pin with which a lady fastens her bonnet is sufficient to pierce the heart and cause instant death; but no sensible or sane person has any excuse for perverting the good and proper use of any of these things. And so we leave the case in question to go down to history as a case of unintentional suicide, in which every precaution was taken to insure death, and not a case where an unsuspecting victim was laid low by a stab in the dark from behind.

THE St. Louis Car Company, St. Louis, has its shops working at the top notch. The increase of the capital stock from \$100,000 to \$500,000 recently seems to have put vigor into affairs, both present and prospective. Besides a large number of orders from Eastern states, some nice local and Western orders are in hand. The cities represented are Brooklyn and New York City Philadelphia and St. Louis.

## AT LAST A VICTIM.

The "Deadly Trolley" Kills a Boy—But under the Most Unusual and Extraordinary Circumstances.—Millions Transported in Safety During the Last Six Years and this Exception Proves the Rule—Practically a Case of Unintentional Suicide.

For four years the STREET RAILWAY REVIEW has investigated every supposed case of death from the shock of the 500-volt direct current, and in vain. Every instance of "the deadly trolley" that from time to time illuminated the columns of the lay press has been faithfully followed down only to find that death has not been the climax of the case. One man who received the full current, was very severely shocked at Auburn, N. Y., and went back to work the next day. His portrait was given, together with a history of the case from the pen of a physician who attended him, who also was associated with the electrocuting experiments at Sing-Sing prison, New York. Nil desperandum has been the "REVIEW's" motto, and patience has finally been rewarded by the finding of an authentic case of death by the trolley current. Although many millions of human beings have been transported by electricity without harm, it has been reserved for a boy and a St. Louis boy at that, to be distinguished as perhaps the first definite case on record of death by the 500 volt direct current.

Fred Burk, aged 16, was working in a cooper shop at 3007 South Seventh street, St. Louis. On May 9, at noon, while on his way home the lad decided upon some original researches in electricity. For this purpose he had procured a quantity of Number 29 wire, of soft iron, bright and clean, such as is used to fasten corks in beer bottles. This he threw across the trolley wire, and began to amuse his companions by showing them "how to get a shock." The lad had previously been at work in an electrical supply manufactory and knew, it is ascertained, something of the power and danger of the current. This "little knowledge" proved a very "dangerous thing." In his attempts "to get a shock" the boy was unsuccessful, until he stepped upon the car tracks and completed the circuit. In the meantime he had wrapped the wire several times around his hand and arm, as described in the report of the physician, which is appended.



Our sketch herewith shown gives the relative positions of the lad, showing him both on the pavement and lying upon the track. When the fatal connection was made he rolled over several times, thus winding the wire about his person, substantially as described by Dr. Faber.

It must be well understood that the boy had knowledge of electricity and its effects, and was unavailingly trying to get a shock until he stepped upon the track.

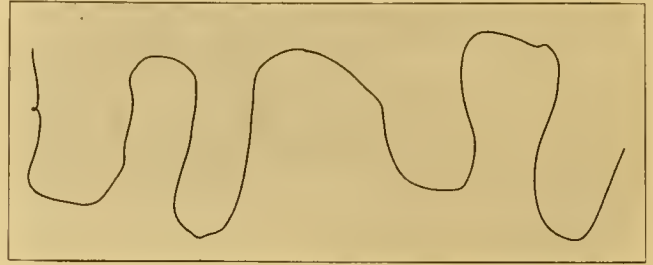

This engraving shows the exact size of the wire used by Freddie Burk, and is engraved from a piece now in possession of the REVIEW, and which was a portion of the wire wound about his body, and furnished us by Dr. Henry W. Faber, the attending physician.

When the circuit was completed the boy fell to the ground across the track, in an insensible or at least semi-conscious condition, incapable of motion. His companions were horror stricken and afraid to rescue him. An alarm was given to a passing pedestrian, who seized a wooden stick and broke the small wire. The boy's body was then pushed onto the pavement and away from the track, and carried to his home. So heavily was his body charged that the rescuer received a sensible shock. The body remained upon the track three or four minutes, and when removed was dead. Dr. Henry W. Faber was called immediately, but was unable to use any remedies or restoratives.

Dr. Faber says: "I saw him about five minutes after the accident. There is no doubt but that he was electrocuted. His skin had a blue waxy hue, but his appearance was otherwise normal. The left arm was burnt to the bones in the hands and fingers, and where the wire was wrapped around his arm it was cut with each wrap. The wire crossed his shoulder, then under the arm pit to the elbow and encircled the fore-arm five or six times, passing over the palm and through the fingers. His right hand and fingers were still more mutilated and burned to the bone. One finger was completely severed from his hand. In falling from the shock the wire fell across his breast, burning through the shirt immediately over the region of the heart, where a hole was burned in his body an inch in circumference and clear to the rib: To this injury his death is certainly attributable. All these wounds were made by the red-hot wire, which acted as an electric cautery and there was no bleeding from any of them. The body smelled strongly of burnt flesh."

The street railway company's superintendent writes that the accident happened substantially as related, and makes the natural enquiry if it is the first on record. The REVIEW is of the opinion that it is the first.

The only lesson is this: Let the daily papers, instead of raising the deadly trolley howl, teach the young idea that danger lies in familiarity with the trolley circuit only when undue liberties are taken, and that hydrogen gas, or cellar stairs are equally fatal. Any comment on the subject from surgeons or electricians will be received with consideration by the REVIEW.



## SPACE FOR EXHIBITS AT ATLANTA.

Space is now being taken for exhibits at the Atlanta convention. A large plat of the building will be found on page 190 of our March issue.

The side track at the west of the building will be a great convenience, but nevertheless it is deemed advisable to ship goods in due time. The hall is engaged for two weeks, beginning October 10, thus allowing ample time for placing and removal of goods. All exhibits must be placed and displayed on or before Tuesday evening, October 16. All counter shafting, pulleys, belts, switches, switch boards, etc., must be furnished by the exhibitors. Exhibitors must not circulate advertising matter or place signs outside their own space without consent of the secretary. Electric power will be furnished at the rate of 45 cents per rated K.W. of the machine actually using current. The minimum charge will be \$15. Applications for space received after June 15 will be allotted whatever space remains. Such allotments cannot be transferred without permission. The Association reserves the right to charge citizens of Atlanta admission fee if it sees fit.

N. W. L. Brown is chairman of the local committee on exhibits, and should be addressed Equitable building, Atlanta, Ga., for any particulars, or applications for space; or application may be made to W. J. Richardson, Secretary American Street Railway Association, 166 Montague street, Brooklyn, N. Y.

## LACONIA'S LOSS.

On the morning of June 3 the town of Laconia, N. H., suffered a loss by fire of \$125,000. Of this total \$75,000 worth of property belonged to the Laconia Car Company, the principal industry of the city. The fire is thought to have originated in the paint shop of the car factory and to have been of incendiary origin. From the paint shop the flames spread to the malleable iron foundry, an important branch of the works, and from that to the setting up shops. In the latter place were stored twenty electric cars for the Brooklyn, N. Y., Highland's street railway, and a number for the West End, of Boston. The setting up shops were two years old, 80 by 150 feet; the paint shop was 50 by 216 feet, and the malleable iron foundry 140 by 200. All were substantial buildings and insured in forty-two companies to the amount of \$47,000. The most serious loss was in the malleable iron department, where a large number of patterns were lost.

The company will begin immediately to rebuild and re-equip the destroyed shops, and the loss, although coming at a disadvantageous time, will not materially affect the progress of contracts in hand or the acceptance of new business.

Manager Putnam, the veteran car builder, says that the new buildings and equipments will be more commodious than the former, and that although Laconia is a little damaged it is still in the ring.

## A FAHRENHEIT SCHEDULE.

The sudden change of May weather, last month, caught a number of New York and Brooklyn citizens on open cars and of course gave them colds. In consequence, "Old Subscriber" and "Pro Bono Publico" rushed into print, and Smith and Jones and Brown rushed to the health commissioner's office to complain of the "fearful carelessness" of the railway officials, with the same acrimony observable in their remarks on the "stalling" closed car two days previous.

Health Commissioner Emery, however, called a council of Brooklyn street railway men to debate the question. There were present, Col. J. N. Partridge, of the De Kalb and Franklin avenue lines; W. A. H. Bogardus, of the Brooklyn City system, and Mr. Tobias, of the Atlantic avenue. No ill-feeling was displayed on the part of any one and an informal agreement was made upon certain rules. When the thermometer registers over 60 and under 65, it is settled that open and closed cars shall be run alternately. When the temperature is under 60 and the day is warm, two closed cars shall be run to every open one. When the thermometer approaches 70, the open cars shall be run at will, and below 60 degrees, closed cars are prescribed.

The New York line, the Dry Dock, East Broadway and Battery, notified the board of health that no open cars shall be run until the temperature reaches 70 degrees.

## TESTING SIGHT OF MOTORMEN.

Since the beginning of modern railroad practice, the care taken to obtain employes with perfect eyesight has resulted in special examinations of applicants for positions and the weeding out of those whose incompetency of eyesight might endanger life and property.

Since the wide use of mechanical traction on street railway lines no particular attention has been given to this important matter, although several accidents have been caused by near-sighted or color-blind motormen and gripmen. Recently, however, the matter has been attracting attention and all motormen on the Consolidated Traction Company, of Newark, N. J., have been ordered to present themselves to the company's physician to undergo an examination of eyesight. Without doubt the careful examination of the eyesight of gripmen and motormen would bring forth some very interesting data.

THE Western Electric Company are about to enter the street railway supply business and make it a speciality. They will carry a full stock of everything, including line material and repair parts for all systems, and be prepared to make quick and prompt shipments.

CINDER blocks for paving have been declared incompetent by the authorities at Philadelphia. Some of the blocks were hard and sound, but so many were soft that it was unsafe to use them. When soft the paving was as brittle as ordinary brick.

## MOTOR INSPECTION.

By William M. Ramsey, General Superintendent Federal Street and Pleasant Valley Passenger Railway, Pittsburg.

The inspection of motors, like many other subjects in our profession, is one upon which a variety of views has been expressed. All agree, however, that motor inspection of some nature is an imperative necessity. The differences of opinion are as to the frequency and to the method of inspection. As to the frequency of the inspection, it is the experience of the writer that managers operating nearly any of the older types of motors, Edison or Sprague No. 6, or any of the T.-H. double reduction types, will find it to their advantage to have a superficial inspection not less than three times each day, in addition to the more thorough nightly inspection. By superficial inspection, is meant an examination of each bearing, and of the brushes of the machines. The inspection of wires—field wires and brush terminals—is of so much importance that it had better be left undone than done in the manner which is almost universally practiced by thoughtless inspectors and shop-men. The usual method is to take hold of a wire and pull it more or less gently to see if it is loose at the terminal or broken under its insula-

screw, countersunk about a quarter of an inch, and shellac or sealing-wax poured over the head to indicate any removal of the cover by unauthorized parties. "Hands off" is painted in large letters upon the cover. It is found that by enforcing these rules that wires will last almost indefinitely, the effect of the oscillation of the car and motors not being enough to be noticeable even after a long time.

The nightly inspection should be most thorough. A point seldom thought of in the inspection of the new iron clad motors is the external cleaning of the fields and field magnets. Carbon dust and street dust accumulates about the field coils, and becoming mixed with grease, which creeps in from no one knows where, sooner or later destroys the field. It cannot be blown out with a bellows, but must be carefully wiped out with waste—the armature being removed for that purpose. Once a month, or every six weeks, is not too often to cleanse a motor in this manner. The usual nightly inspection of brasses or bearings is too often only superficial, especially as to the clearance of the armature between its pole pieces. It is not enough to see light between the armature and bottom pole-piece. The armature should be turned around and viewed from every position.



MOTOR BOARD.

tion. The obvious result of this is, that wires which might last for years if untouched, are worn out in a few months by such barbarous handling, and a constant wail of "broken field wire," or "another loose brush terminal," is heard from motormen and conductors. Motormen and conductors, themselves, soon learn to look for trouble first from broken wires, and like inspectors, pull and jerk the wires every time their car "bucks," and so matters grow worse, and will continue to grow worse until the manager makes it a punishable offense for any one, except the shop foreman, for instance, to pull a wire or to lay hands upon a motor wire. The writer has in use upon about one hundred and twenty motors of the Sprague No. 6 type, a "motor board," designed especially to obviate the trouble of loose wires. It has the usual six terminals or binding posts, separated by a partition of ash, one inch high. The placing of the cover on the board fastens each wire down to the board for a distance of about one inch and-a-half from its entrance to the binding post. This prevents the ordinary vibration of the wires from causing a break at the binding post. The cover of the board is fastened at each corner with a flat headed wood

In the inspection of controllers it is common practice to dress up the contact points with a file and allow the copper filings to fall where they will; this is frequently the cause of disastrous results. The cylinder should be removed occasionally, about once each month, and the back board thoroughly cleaned from copper and brass filings.

The every day inspection of grease cups, commutators, tightening of bolts, etc., need not be more than mentioned here, because all inspectors know that swift retribution follows any neglect of these common duties. As to the number of cars which it is advisable to place under each inspector's care, practice will vary; but from six to ten of the old double reduction to three times that number of single reduction, is a fair estimate. It can be set down as a maxim, that the annual cost of motor repairs varies inversely as the amount paid for inspection, and inversely as to the quantity of attention and intelligence displayed by inspectors.

A DAILY paper says that a street car has two currents on; one at each end.

PERSONALS.

O. T. CROSBY, of the White-Crosby Company, is in Europe.

A. J. PAINTER, inventor of the Painter Motor, of Pasadena, Cal., died recently.

T. M. SANTEE, director of the Safety Clutch Brake Company, Philadelphia, was a REVIEW caller of the month.

JOHN F. OSTROM, sales agent for the Pennsylvania Steel Company, Philadelphia, was a May caller at the REVIEW office.

F. C. RANDALL has assumed the duties of western manager for the J. G. Brill Company, with offices in the Monadnock block.

DANIEL J. DOWDNEY has opened up a New York office for the McGuire Manufacturing Company, of Chicago, at 171 Broadway.

MANAGER C. D. WYMAN, of the Milwaukee Street Railway Company, has removed his family from New York City to Milwaukee.

WILL H. THOMPSON, formerly superintendent of the Lima Electric Railway, was married recently. The bride was Miss Haller, of Lima.

R. BISSELL SCRYMGEOUR, traveling in the interests of the "Wells" light, that is so extensively used for night railroad construction work, made the REVIEW a recent call.

JOHN BROLLES, assistant secretary of the Third Avenue Cable Railway, New York City, read a paper before the Polytechnic School, May 17, on the "Third Avenue Cable Road."

H. H. ARCHER has retired from the general management of the Scranton Traction Company. His brother, Taylor Archer, master mechanic, also retired. Manager Archer is in ill health.

JOHN McCORMICK has severed his connection with the Heine Safety Boiler Company and will hereafter be identified with the Sterling Company, with offices at 126 Liberty street, New York.

EVERETT K. DAY, the well-known and competent superintendent of the Mousam River Electric Railway, of Sanford, Me., has resigned, and will spend the summer in rest at Hallowell, Me.

GOVERNOR FRANK BROWN, of Maryland, has accepted the presidency of the Baltimore Traction Company, vice T. Edward Hambleton, resigned. Governor Brown is the second state executive to be thus exalted. Ex-Governor Bowie has been president of the City Passenger Company for twenty years.

MALCOM D. PECKHAM, brother of Edgar Peckham, of the Peckham Motor, Truck & Wheel Company, died last month from injuries received from an assault made upon him by a former employe.

A. K. BAYLOR has been made assistant engineer of the railway department of the General Electric Company, with headquarters at 44 Broad street, New York. He has a deserved reputation as an engineer.

CONGRESSMAN TOM L. JOHNSON is a terror to bicycle makers. He weighs 250 pounds, and broke down three machines and nearly killed two attendants in learning to ride. Before the lesson was over, however, he rode with great ease.

LIEUTENANT BADT succeeds C. O. Daigh as general sales agent of the Siemens-Halske Company at Chicago. Lieutenant Badt is well known in his former connection with the General Electric Company, and will prove a valuable man.

CHAS. J. GUSTAFSEN, superintendent of the Chattanooga Street Railway Company, has resigned his position to go into business for himself. His headquarters will be at Chattanooga, and street railway specialties of his own invention his field.

CHAS. H. WILSON has been appointed general manager of the railway department of the General Electric Company, with headquarters at Schenectady. Mr. Wilson has been with the General Electric since the start, and is a thoroughly competent man.

THE Grand Rapids Eagle pays the following tribute to J. R. Chapman, on his retirement from the management of the street railway of that city:

Mr. Chapman's retirement from the management of the street railway system will be generally regretted in this city. He is a man of wonderful force of character, conservative but determined. He will leave behind him an enduring testimonial to his executive ability and matchless generalship in one of the best street railway systems in the world

THEO. P. BAILEY, of the Chicago office of the General Electric, has been made assistant western manager of this territory. The honors and duties of the position have been well placed, as Mr. Bailey's extensive knowledge of all details of the business as well as of the territory fit him for the incumbency. He has heretofore, it is needless to mention, been manager of the railway department.

MAY 18th, as Wm. W. Nugent, western manager of the C. & G. Cooper Co., was about to board a street car in Chicago, he was struck and run over by an express wagon. His head struck the pavement with such force that he was rendered unconscious for about four hours. No bones were broken, but he was severely bruised. He was taken to the Alexian Bros. Hospital, but was afterwards removed to his home, where he was confined to his bed for over two weeks.

## THE MICHIGAN STATE STREET RAILWAY ASSOCIATION.

The street railway men of Michigan have formed an association for mutual benefit, under the name of the Michigan Street Railway Association. The meeting was called at Grand Rapids, where the first annual convention will take place September 19, 1894.

The following officers were elected to serve until that time:

President, W. L. Jenks, City Electric Railway Company, Port Huron.

Vice-president, W. Worth Bean, St. Joseph & Benton Harbor Railway & Light Company, St. Joseph.

Secretary and treasurer, B. S. Hanchett, Jr., Consolidated Street Railway Company, Grand Rapids, Mich.

The executive committee consists of the officers and David H. Jerome, City of Saginaw Street Railway Company, Saginaw; Strathern Hendrie, Wyandotte & Detroit River Company, Detroit.

### A. J. WURTS ON LIGHTNING ARRESTERS.

The Chicago meeting of the American Institute of Electrical Engineers is becoming a more important event each month. At the May meeting the room in Armour Institute in which it was held was overcrowded, although it had a seating capacity of 140. The audience was distinguished by the large number of practical electricians present. The interest of the evening centered around the lecture on lightning protection by A. J. Wurts. It is not strange that the lecture proved a drawing card, as Mr. Wurts is undoubtedly the highest authority on lightning in the world. He has made it his life study, and being in charge of that branch of work for the Westinghouse Company, has every facility for the study of lightning discharges both in nature and in the laboratory. He has spent much time in regions where thunderstorms were frequent and violent.

The lecture began with the statement that electric lines are never struck by lightning in the sense in which the word is ordinarily used. That is the lines are never struck with a discharge which passes through many feet of air and shatters whatever comes in its way. The danger to electrical apparatus comes from static charges on the lines. It was pointed out that much present trouble is not so much with the arresters themselves as with the small number used and their unfavorable location and installation. The fact that there are nodal points along the line where discharges will at some critical times not take place, makes it impossible for one or two arresters to protect a line. The only safe way is to have a number of arresters scattered over the line and then some of them will be sure to take a discharge. To make plainer the nodal point principle, Mr. Wurts used a blackboard diagram which he said could not be considered as a mechanical analogy, but simply served to illustrate the point. In the accompanying diagram the curved line represents a trough in which a ball rolls.

At intervals along the trough are holes A, A, and B, B, through which the ball can drop. The ball in rolling will attain its greatest velocity at the low points A, A, and its least velocity will be at the crest of the curve. Consequently the ball will go over the holes A, A, without falling, but it will fall through the holes B, B, because its velocity at those points is so low. If it be imagined



now that the holes represent lightning arresters along the line, the necessity of having plenty of them to catch the nodal points is clearly seen. It is best if possible to have enough line arresters so that no station arresters are needed, as the station is a very bad place for them. They should be outside if possible. This was still more forcibly brought out by L. Gutmann in the discussion later in the evening. Mr. Gutmann advocated the use of the term lightning diverter instead of arrester. In one case, however, that had come under his notice he thought the term arrester was very appropriate. A certain station in the state of New York had an imposing array of lightning arresters artistically arranged. One day a thunderstorm came up and the aforesaid instruments "arrested" all the lightning so effectively that the station was partly burned down.

During the course of the evening practical demonstrations were given on the action of the Wurts arresters. The non-arcing metal arresters brought out several years ago are not suited to anything but alternating current circuits, as the direct current dynamo arc follows the discharge in these arresters. An arrester was finally evolved for direct current circuits, which consists simply of a discharge path made by charred grooves in a block of lignum vitae. This is the railway arrester now used. Some experiments were performed in which the two electrodes of the arrester were connected to the two sides of a 500-volt circuit. Discharges from a static machine were then made to pass across the arrester, momentarily short circuiting the dynamo, but the arc broke so quickly that a six ampere fuse was not melted.

The subject of grounds was discussed at length. Mr. Wurts stated that since lightning arresters had been made so cheap, the main obstacle in the way of the use of a large number along the line is the cost of grounds. On railway circuits, however, grounds can generally be easily obtained by bonding to the track.

A MAN named Johnson was found not long ago in the vault of the cable conduit at Wells and Illinois streets, Chicago, with his head severed from his body by the rope. The unfortunate man had evidently, by accident or design, thrust his head between the rope and sheave. He was not an employe of the company, and of all suicidal methods, this would seem the most painful.

## AN INTER-STATE ELECTRIC RAILWAY.

The Complete and Modern System of the Cincinnati, Newport & Covington Railway.

From Fountain Square, Cincinnati, O., to South Covington, Ky., is four miles as the crow flies and about five miles as the Cincinnati, Newport & Covington takes the passenger from one state to another. Besides this direct line which passes through the central portion of the city of Covington, other lines ply through West Covington, Central Covington, Newport, Bellevue, Dayton, Ludlow and Milldale, all suburbs of Covington, on blue grass soil and consequently within the metropolitan area of Cincinnati. From this extensive territory, all dependent to a greater or less extent upon the two main centers, Cincinnati and Covington, the Cincinnati, Newport & Covington Street Railway draws its traffic. Cincinnati has a population of 325,000, Newport, 30,000, and Covington, 45,000, with enough from the smaller villages to give a

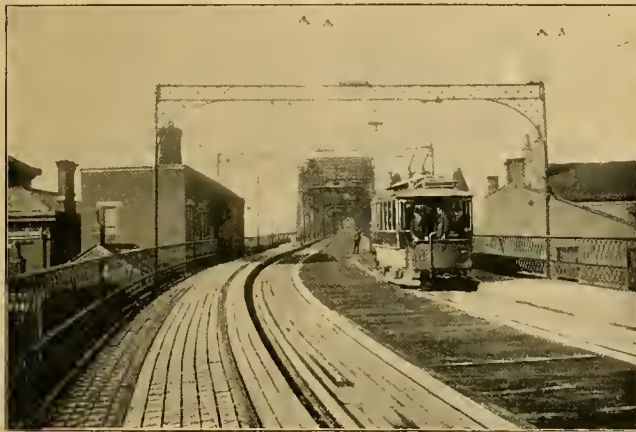

NEWPORT END OF CENTRAL BRIDGE.

possible total riding population of 420,000. The system is a combination of previously existing horse lines (to be changed to electricity), lines now electrically operated and to be built and in process of construction. The rapidly developing manufacturing centers of Newport and Cincinnati will later on afford the system still further traffic, and the proposed resorts and pleasure grounds will make evening and holiday traffic as remunerative as the rush trips.

The road was organized July 1, 1892, and has now 55 miles of track in operation, of 5 feet 2½ inches gauge. Both T and girder rail is used, of 56 and 80 pound sections, respectively. It was rolled by the Pennsylvania Steel Company, Carnegie, the Maryland Steel Company and the Johnson Company. One hundred and twenty-five cars are now in commission. These came from the factories of the Brownell and the Laclede Company, St. Louis, and from Stephenson, of New York. Eighty of the cars are 30 feet over all and the rest 24 feet. Two Westinghouse 25-horse-power motors are attached to each car, and the trucks in use are made by Brownell and by Stephenson. The Bass Foundry, the Griffin Company and the Baltimore Wheel Company made the

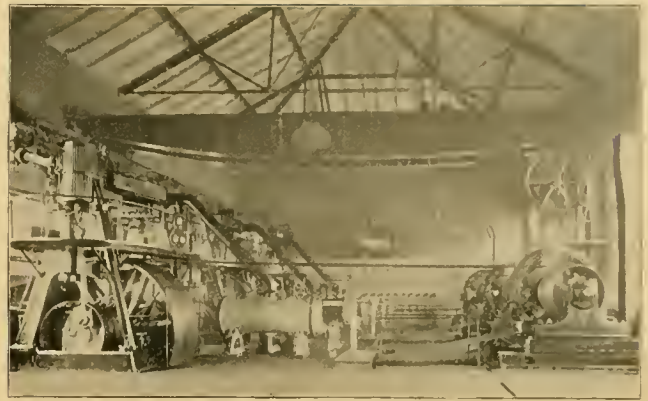

POWER HOUSE AT NEWPORT.

wheels. Two power stations are required for the service, with nine engines, aggregating 3,000-horse-power. The engines were built by the Cleveland Shipbuilding Company, Lane & Bodley, McIntosh & Seymour and Armington & Sims. Ten boilers, with a total of 2,000-horse-power, are in use. They are of the well-known Babcock & Wilcox pattern, and the feed-water is rendered fit for use by the Warren Webster pattern of heaters and purifiers. Ten generators, made by Westinghouse, furnish 2,500-horse-power for the operation of the line. It will thus be seen that, mechanically, no pains have been spared to make the equipment complete and serviceable. As to station and line economics, the cost of repairs per car mile is \$.0040; cost of coal consumed per car mile, \$.0119 per mile, and the cost of motive power, including coal, is \$.0241, which showings speak volumes for the careful management and ought to rejoice the stockholders.

At the power station two crews are employed on twelve-hour shifts, and these in turn shift every two weeks from night to day. Each crew consists of one engineer, one oiler, one dynamo and switch-board tender, one fireman and one ash and coal heaver, making five men to the shift and ten men to the station.

The feeder system is complete in sections. Two-thirds of the line is single trolley and the remainder, that portion



BOILER ROOM, NEWPORT POWER STATION.

which crosses the bridge and operates in Cincinnati, is double trollied. There are twelve ground returns from rail to the station, and one overhead return, besides ground plates placed every thousand feet. Lightning arresters are placed on poles every 1,200 feet. The type used is the Garton arrester, the performance of which is reported efficient. On the cars and on feeder lines entering the station, as well as on the switch-board, the Westinghouse arrester is used.

Several home-made devices are in operation, notably a track broom, which is so efficient that letters patent have been applied for it.

As to paving on the city streets, granite block, brick and asphalt is in use. On this portion of the line, 7-inch girder is laid. On suburban lines, T rail is preferred. In one instance, T rail is paved to with planks, and the superintendent is of the opinion, "that T rail paved to with brick will make the best road bed, both for the street railway and for the municipal authorities." Superintendent Jenkins, in relation to mutual fire insurance, remarks: "It has always been my opinion that a mutual fire insurance, or putting away of so much per year as an insurance fund, to provide against loss by fire, is what the street railways will have to do, as the present rate of insurance is a hardship that most of the companies cannot stand up under. With our arrangements of night and day foremen at the different car houses, and the number of hands in our employ, the arrangement of hydrants inside car houses and stations, with hose attached to plug and shelved on wall of build-

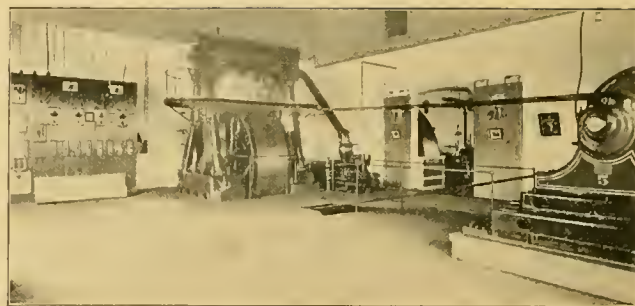

INTERIOR COVINGTON STATION.

ing, ready to have water turned on instantly in case of fire, we think we are free from all danger, except in case of lightning entering the barns or stations and so set them on fire, and even this possibility is almost precluded by our complete system of lightning arresters, both in the station and on the line."

The summer resort business of the Cincinnati, Newport & Covington is well provided for, and the bright and progressive management readily appreciates this feature of traffic. The following pleasure spots are noted: Latonia, at the end of the Milldale line; Carnival Park, at the State and Greenup street loop; Working Lake, a fishing resort; a half-mile trotting track at the Rosedale terminus; Clark's picnic ground and

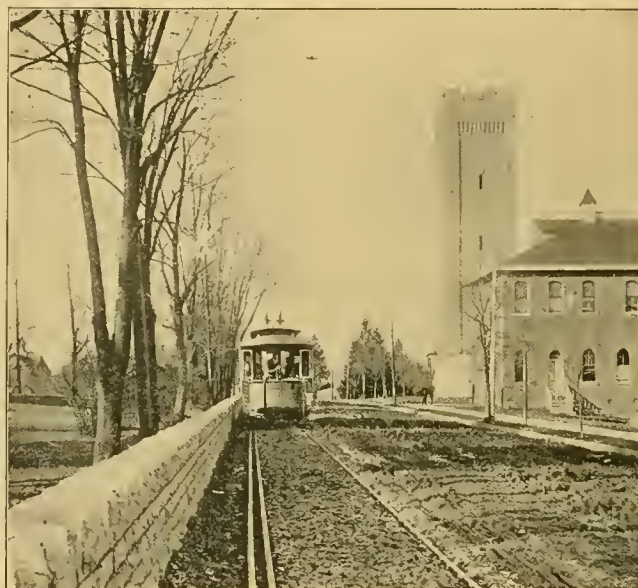

FT. THOMAS.

rifle range, at the Dayton terminus; the Fort, at the end of the Fort Thomas line; Ludlow resort, to be opened this summer with a beautiful lake of eighty acres. This is the resort par excellence, and no expense will be spared to make it acceptable to all tastes, fads and conditions. Here will be established rifle ranges, launches, gondolas, merry-go-rounds, photograph galleries, toboggan slides and like excitement for hoi polloi. A portion of the 60-foot road way will be devoted to equestrians. This drive is two miles long. Here, too, a bathing pavilion will be established and a competent instructor will be engaged to teach the young idea how to paddle. It is the intention also to establish a laundry in connection with the bathing house, and while you bathe, your shirts will be laundried and your clothes pressed. This is not a fake, but really contemplated.

One of the features of the line that must be noted, is the suspension bridge, shown in our engraving, which crosses the Ohio river from Cincinnati to Covington. It is 2,252 feet long over all, 36 feet wide, and the main span runs 1,005 feet. The Central bridge, spanning the Ohio from Newport to Cincinnati, is 2,966 feet long, 38



COVINGTON APPROACH SUSPENSION BRIDGE.

feet wide, with two river arms, suspended spans 520 feet long, a cantilever arm at the Cincinnati end 252 feet long, and a similar span at the Newport end 250 feet in length. Its height above low water is 102 feet.

The average earnings per day of the system for the six months ending December 31, 1893, were \$1,232, an increase of \$310 a day over the previous year.

The officers and directors of this excellent system are: John J. Shipherd, president, Cleveland, O.; Chas. E. Orr, Pittsburgh, Pa., vice-president; Jas. H. Hoyt, Cleveland, secretary; Howard P. Eells, Cleveland, assistant secretary and treasurer, and J. B. Foraker and W. E. Hutton, Cincinnati.

#### A VETERAN STREET RAILWAY MANAGER.

W. J. Hart, general manager of the Union Street Railway, of Saginaw, Mich., has been a street railway superintendent for thirty years. Great as have been the changes in that time, Mr. Hart has not fallen back to the list of old timers who were in their glory in the day of

horse cars, but have now sunk into oblivion. He is, on the other hand, as wide awake, aggressive, and full of modern ideas as if recruited to the street railway ranks but recently, while his long experience is certainly not without value. He is now 47 years of age. He received a public school education and is a graduate of the Yates Polytechnic Institute,



W. J. HART.

Chittenango, N. Y. At eighteen he became superintendent of the Syracuse & Geddes Street Railway, an interurban from Geddes to Syracuse. He had continuous charge of that road for twenty-four years. In 1869 he took charge of another Syracuse road, the Genesee & Water Street Railway. He managed the two roads until 1890. During his service many extensions were built and good dividends paid. He was also one of the incorporators and directors of the Eastwood Heights Electric Railway, and was consulting engineer in organizing and building many street railroads throughout central New York. He was a charter member of the New York State Street Railway Association. In 1890 he became assistant manager of the consolidation of Syracuse roads. He remained with this corporation only a short time, however, before resigning and accepting the general management of the Saginaw Union Street Railway. This road, which has recently gone through a thorough reorganization, has twenty-four miles of track, all of which is this year being relayed with 60 pound groove and T rail. A fine new car barn and machine shop has just been erected for the accommodation of the forty-five cars in use. A beautiful pleasure resort will be opened up this season.

During his long street railway connection Mr. Hart has devised many improvements in the way of car trucks,

snow plows, etc., and is said to be the first man in the United States to put stoves in street cars. During his management in Syracuse his road transported over 25,000,000 passengers, without a death resulting from accident either to passengers or others.

The Saginaw Union road will be remembered as one of the first to encounter trouble from electrolysis. The poor return was in this case aggravated by the presence of a great deal of salt and sulphuric acid in the soil. Mr. Hart has made a careful study of the matter from the beginning, and has come to the conclusion reached by the majority of students of the problem, viz., that a reduction of the return resistance by heavy bonding is the first requisite in preventing this trouble.

#### SPONTANEOUS COMBUSTION AT QUINCY

The provident management of the Quincy, Ill., Street Railway Company, at the beginning of the miners' strike, laid in a big supply of coal. It was not of very good quality, but it would make steam. It was stored in the boiler room near the boilers and behaved admirably for a time, but finally ignited by spontaneous combustion. The fire got a good start during the night and simply roasted the iron roof off of the boiler house and burnt

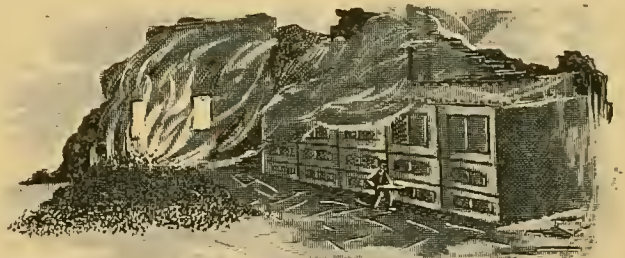

down the walls of the room, which were 40 by 50 feet. The boilers were not damaged and steam was kept up by shoveling the coked and burning mess into the furnaces. It was a curious scene with just the bare boilers without roof or walls, and the stack sticking up lonely and forlorn. The loss was \$3,000, with no insurance, as the room was supposed to have been fire proof.

THE "Pennsylvania Traction Company Relief Association," is the title of the organization of the Columbia, Pa., street railway employes. The weekly dues are 12 1/2 cents, and the sick benefits \$5 a week. Upon the death of a member, his nearest relative will receive \$75, and upon the death of a wife, the husband will receive \$50. At the death of a member the others are assessed \$1, and at the death of a wife of a member, each one is assessed 50 cents. The president is Samuel Charles and the secretary George Gardiner.

JAMES G. FLOYD, agent of the Barrows electric elevated system, proposes to build a line on the route of the Harrisonville, Randallstown & Granite Rapid Transit Company, near Baltimore, Md.

### RODE A MILE A MINUTE IN A WHEEL.

Young Harry Skidmore, of St. Louis, had an exciting experience last month. He is an oiler at the electric power house of the St. Louis & Suburban Street Railway Company, and while engaged in lubricating a journal was caught in a wheel and whirled around a number of times with frightful velocity. When the horrified employes regained their senses and stopped the engine,

Skidmore was rescued in a badly bruised condition, and his escape is little short of a miracle.

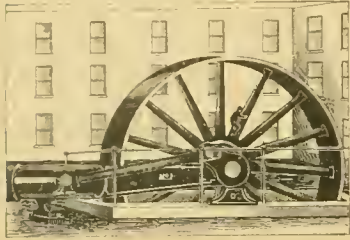

### MUSTN'T FLIRT.

The manager of the Brooklyn Heights Street Railway, Brooklyn, N. Y., has posted this notice in the car barns:

CONDUCTORS AND MOTORMEN  
MUST STOP  
FLIRTING ALONG THE LINE.

The order arose from a petition of the women patrons, who asked that the employes be in some way restrained from the pernicious habit engendered by the prevailing and proverbial softness of the conductorial heart.

### THE NEW W. S. HILL SWITCH.

The W. S. Hill Electric Company, of Boston, has made several improvements in substantial switch con-

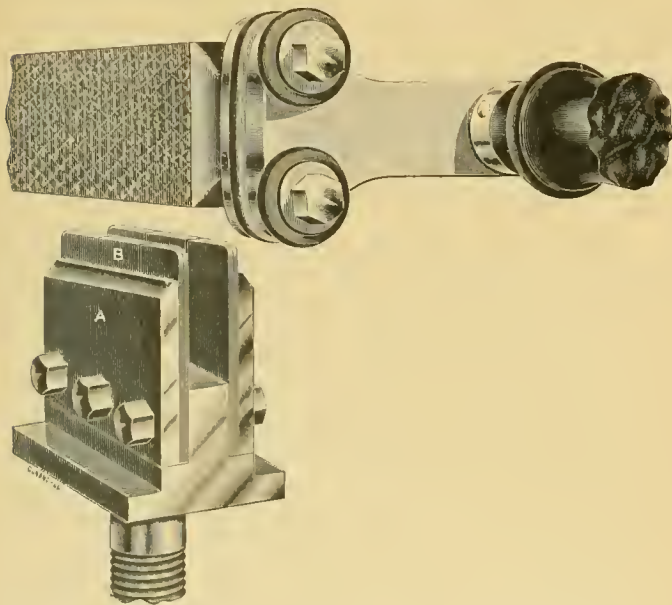

struction, which have recently been patented and which have been incorporated in the switches made by them.

The first improvement is in the method of securing the

blades to the yoke by two bolts instead of one. With one bolt the blades are liable to be twisted so that one breaks contact sooner than the other. To overcome this defect and produce a more mechanical and substantial device, the outer ends of the blade and yoke have been broadened to make room for two screws. The second improvement consists in backing up the regular flexible contacts B, by a reinforcing plate A. It has heretofore been the custom to use nothing but the copper strips B, and these of a necessity being flexible, were liable to spring apart by constant usage, thus impairing the contact. By the method shown the flexible contacts are kept in proper position.

### SAN FRANCISCO'S SLOT BRAKE.

The dangerous grades of San Francisco's streets are too well-known to require any particular mention. Suffice it to say that no city in the world has such a succession of grades to overcome by mechanical traction. The precipitous hill on Washington street, from Jones to Mason, was the scene of a hair-lifting runaway not long ago. Car 46 was the fated one and only the merest chance intervened in two instances between wreck and ruin of cars crossing the path of the wild train.

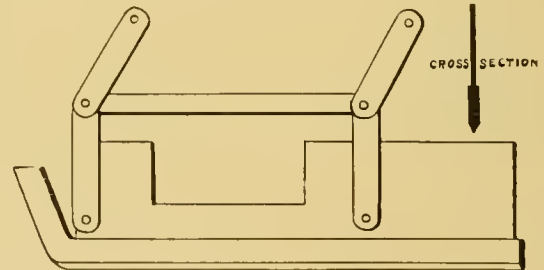

Eye-witnesses of the runaway stood spell-bound and the railway men were helpless, but their shouts brought the dazed gripman to his senses. He then applied the slot brake, which brought the car to a stop within 150 feet.

In taking a steep grade in San Francisco it is customary for the gripman to draw the grip as tightly as possible to bring the car to the rope speed. This the gripman had done, but the shank of the grip broke and before he realized what had happened had fallen into the slot and the car was shooting down grade. He mechanically applied the foot and hand brake, which are respectively track and wheel brakes, but to no effect. The track was slippery and down went the car gaining momentum with every second and with nothing to prevent it from leaving the track. The conductor twisted the rear brake until a shower of sparks fell from the shoe in fiery torrent. Then the slot brake was applied by the gripman and the car stopped.

The slot brake referred to is a wedge of steel 2 feet long, 6 inches wide and  $1\frac{1}{4}$  inches thick, tapering at the lower edge to a little less than the thickness of the slot. It is worked by a toggle joint and thrust into the slot by means of a lever. It is used only in the



greatest emergency and is driven into the slot by the momentum of the car. It usually has to be removed by cold chisels, as the great heat generated welds the steel of the slot and of the wedge together. Our engraving represents the brake and toggle joint.

It is the invention of an Australian, but was first used by Howard C. Holmes, of the Powell street line, San Francisco. On the San Francisco lines the grades are fearful, running frequently from 10 per cent to 19.8, as the case just mentioned. With these the slot brake is imperative, but since its adoption several years ago there has not been a serious runaway on the system.

A STATION OUTPUT RECORD.

The Cleveland Electric Railway has a graphic method of keeping its ammeter readings for each day, that is much easier and more available for future reference than any record kept by figures. It consists in having a book

CLEVELAND ELECTRIC RAILWAY CO.---ELECTRIC DEPARTMENT.



with pages 18 inches high by 16½ inches wide. Our engraving represents a piece torn from the top of one of the pages. On each page is plotted the ampere curve for a day, as taken from half-hour readings. Vertical space, represents amperes and horizontal distance time. At the bottom of the page are blank spaces for entering the condition of the weather, temperature, etc.

A SCALE OF ENERGY.

A story, says the Railway Review, is told by a gentleman in one of whose shops is a German mechanic who is something of a genius. Lying on this German's bench

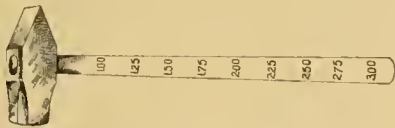

a gentleman connected with the works saw a hammer, on the handle of which were figures corresponding to those in the little accompanying sketch.

“What is that for?” the man who was making the rounds asked.

“Vy, don’ you know vot dot’s for? Ef I got von tollar a tay I takes hold of him like dot,” and, suiting the action to the word, he grasped the hammer handle down over the dollar mark, and pounded away about as effectively as would a red headed woodpecker. “But ef I got tree dollar I takes hold of him like dot,” and he grasped the handle at its extreme end and swung the

hammer with a force that would have driven a cold chisel a quarter of an inch into steel at every blow. Anyone who has had much experience in handling men will readily see in the German mechanic’s hammer handle a very suggestive object lesson.

BRICK PAVING.

By J. D. Wardle, City Engineer, Cedar Rapids, Iowa.

Brick paving, while yet in its infancy, has passed the experimental period and is fast taking the place of all other pavements; and while it is not the object of this article to detract from or lessen the appreciation of other pavements, yet it is the belief of the writer that as brick, as a material for paving, becomes better known, and as the means to supply the demand are more and more developed, brick paving will be more called for and oftener specified, and that the time is not far distant when

the main streets in our smaller towns and the principal country roads will be paved with brick as well as the streets in larger cities and towns.

It is but a few years since brick paving was somewhat of an experiment, and the kind of brick required, the method of laying, and the nature and amount of foundation were questions upon which good engineers might differ, and the tyro was compelled to use his best judgment and learn by observation and results. And while results are now in no ways doubtful, yet we have by no means reached perfection, and the engineer, contractor or manufacturer, who has any desire to obtain the best pavement, must not stop experimenting or studying results.

Like all other pavements much depends on the foundation, and as we have had almost all kinds of foundations we ought to know something about what is best and most practical.

The early specifications called for foundations all the way from one with a six-inch “Telford” base and six inches of small macadam with two cushions of sand and a two-inch course of brick, to one where all the foundation called for was the natural soil to receive the four-inch wearing course of brick.

The kind and amount of foundation should be determined by the nature of the sub-soil and the cost of material. In a sandy sub-soil where brick suitable for lower course brick can be obtained cheaper than macadam, a two-course paving on sand with a sand cushion between courses is perhaps the best; but where the sub-soil is a loam, or clay, or refuse filling, a six-inch

macadam foundation thoroughly rolled and compacted will give the best results; on and into this should be placed enough sand to fill all interstices and leave a cushion of sand at least one inch and not more than two inches in depth.

Concrete as a foundation is specified in many places, but the places where and the conditions under which it is superior to macadam are few, and then oftentimes the additional expense is not warranted by the conditions or the necessities of the case.

Whatever foundation is used, it is essential that not only the foundation, but the sub-soil as well, be thoroughly compacted and settled. If the sub-soil be sand this can best be done by flooding and tamping. If loam, or clay, or refuse filling, a heavy roller is a necessity, and the best results can be obtained with a ten or twelve ton steam roller. A "macadam" or "concrete" foundation may and should be rolled with fully as heavy a roller as the sub-soil or natural foundation. In a two-course pavement, the under course should be rolled with a hand roller, to settle the brick firmly in the sand. Whatever the foundation, there should be a cushion of sand under the top course of brick, at least one inch and not more than two inches deep.

For a wearing surface, brick thoroughly burned and vitrified, when made of clay adapted to the manufacture of paving brick, have proven superior to any other known substance that can be used in street paving. Costing less than granite or asphaltum, it is less slippery and will out-wear either, is less noisy than granite and costs less for repair than asphaltum.

From a sanitary standpoint, brick pavement is the nearest perfect of any, it is easily kept clean, is impervious to water, and does not decay.

A paving cement or pitch is sometimes used to fill the joints between the brick. It costs about twenty cents per square yard, and the paving is not enough better to warrant the additional expense. About the only claim of superiority that is made in its favor is, that it makes a water-tight joint, and the same thing is obtained with a sand joint after the street has been worn a short time.

The quality of brick to be used is of the utmost importance. There are several makes of brick that have had actual wear enough in street paving to prove their reliability, but the brick manufacturing industry is growing and spreading so far and rapidly that the engineer will oftentimes be asked to accept brick that has not had the test of actual wear. Any manufacturer that expects to sell brick to be put into paving should also expect to guarantee such brick in the pavement. Many of the brick being used could be safely guaranteed to last fifty years or longer.

The usual tests for paving brick are the crushing test, the absorption test and the abrasion test. The poorest brick used should not crush under less than 6,000 pounds per square inch, should not absorb more than 2½ per cent of water in 24 hours, or lose more than 10 per cent in 5 hours in a rattler used to clean castings running 30 revolutions per minute with ten times its weight of castings put in the rattler at the same time.

If we persist in demanding better brick from the manufacturers, better work from the contractors, and inspection from the engineers, the future will see the same or greater progress in the line of better and more satisfactory pavements than the past.

## TWO ELEVATED ELECTRIC RAILWAY SYSTEMS

The Johnson elevated railway system is shown in the accompanying engraving. It demands a series of suspended bents of 150 feet span on the suspension bridge style. At intervals, a heavy steel support connects

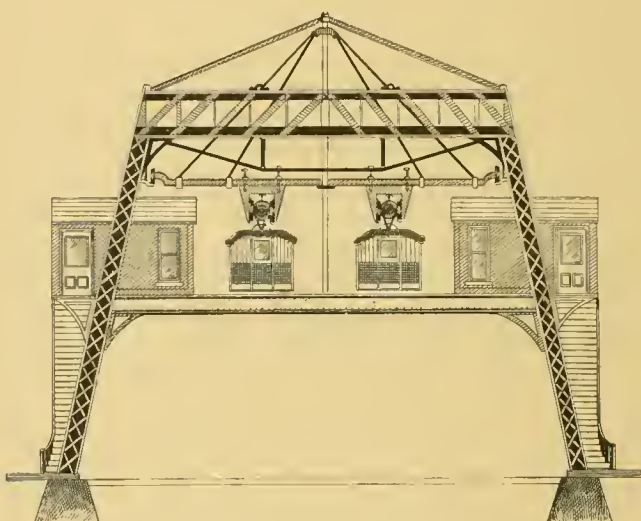

THE JOHNSON SYSTEM.

across the top by a truss on which the cables rest. The rails are held in position by means of heavy steel stirrups or yokes, with horizontal top bars and vertical arms hanging from each end of the bar. These arms turn in and up and upon them are set the rails for the car. The car

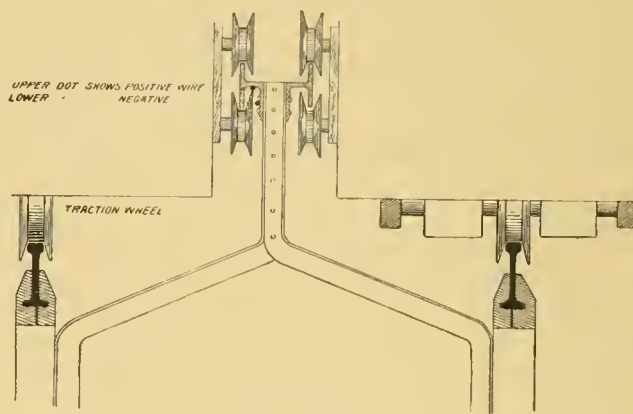

BROTT SYSTEM.

s suspended upon these rails. A motor is hung between the two pairs of wheels to a truck. The total weight of each span with two cables is 17 tons, with a strain of 8½ tons to the mile. The cable will be 3 inches in diameter, and the cost is estimated by the inventor to be \$80,000 a mile! Electricity is of course to be the power and unlimited speed is promised together with absolute safety as in all like affairs. It is a strong reminder of

the St. John V. Day system, illustrated by the REVIEW two years ago.

THE BROTT SYSTEM

is an elevated electric, designed by G. F. Brott, McGill building, Washington, D. C., and furnishes the side rails shown in the engraving as a track for the steadying wheels of the car. The supporting track rail is held in position by the two cast iron pieces fitting on the top of the post. The side rails prevent oscillation when the car is at rest; while in motion the car balances on the supporting rail. The flanges on the running wheels are very deep. The side rails form also a conduit for the trolley wires. A motor on each side of the supporting wheels drives the vehicle. It is proposed to build a line on this principle from Washington City to the suburbs. To this end a charter has been applied for to congress, and the claims of unlimited speed and safety made.

SPRINGFIELD PAVEMENT TO T RAIL.

W. L. Dickinson, superintendent of streets, Springfield, Mass., has an article in "Good Roads," on the effect of tracks on street repairs, in which the accompany-

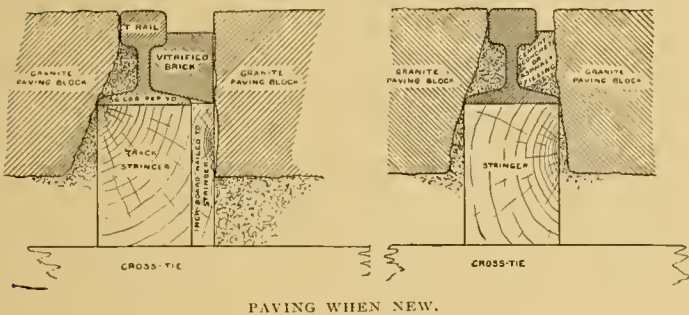

PAVING WHEN NEW.

ing sketches are given of the two methods of brick paving to T rail, as practiced by the Springfield Street Railway Company. The moral is obvious. We might also remark that had there not been so much space left for the flanges of the car wheels the results in both cases would have been more favorable. As long as there is sufficient room next to the rail for vehicle wheels to enter, there

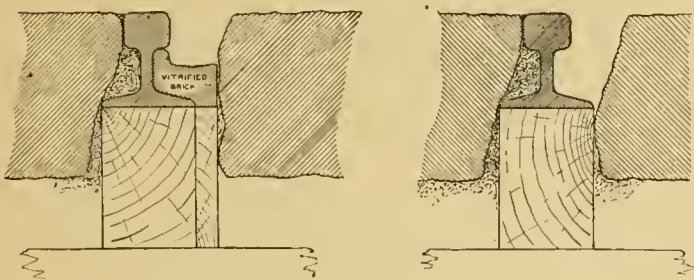

AFTER ONE YEAR.

will be excessive wear at that point. The common practice of paving close to the rail head, leaving only enough room for the flanges, is the correct one, as there is then not only the least jar when driving across the tracks, but there is no tendency for the vehicle wheels to get into the rut next to the rail and stay there. A large space next to the rail is hard on both vehicles and paving.

SOLAR CARBON AND METAL BRUSH.

The Solar Carbon Company, of Pittsburg, has secured the right to manufacture the combination carbon and wire gauze brush shown herewith. It is made of successive layers of carbon and wire gauze. The copper improves the conductivity of the brush, while the lubrication is practically as good as with a pure carbon brush. The product is already known to street railway managers and is giving good satisfaction.



THE LATEST ON WORM GEARING.

Philip Dawson has been carrying on some experiments during the past year at Leeds, England, with some worm-gear street railway motors designed by the late Anthony Reckenzaun. These tests showed an efficiency higher than that usually ascribed to worm gearing. The trouble with worm gearing in the past seems to have been greatly aggravated by an improper understanding of the necessary qualities of such gearing. Mr. Dawson found an efficiency on the trucks in question of from 84 to 95 per cent. The worm was turned out of a solid piece of steel and was well polished. It is 6 inches in diameter, and has a treble thread of 6 inches pitch. The worm wheel is of phosphor bronze, 15 1/4 inches in diameter. The pitch of the threads is 45 degrees, the angle that gives the highest efficiency. Mr. Dawson concludes that to get the highest efficiency with worm gearing, there must be a high peripheral speed, a limited pressure between the teeth, a multiple thread, and a 45 degree angle between plane of thread and axis of worm.

THE MINNEAPOLIS TRANSFER.

On May 1, the Minneapolis Street Railway Company put in force its new transfer system for the city lines. There are 20 styles of the ticket in use for the 20 different points of transference. The engraving tells its own

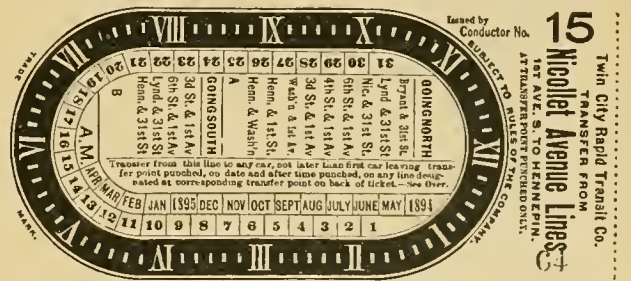

story of the hour, the line to and the line from which the change is made. Various colors of the ticket denote the routes. Manager Hield reports that the method is very successful so far. The transfer arrangement is the result of a special ordinance.

**SCHEME TO DAM THE NORTH CHANNEL.**

The most daring project for power production that has appeared recently is the one to build a dam across the North Channel, between Ireland and Scotland, for the purpose of utilizing the strong currents which now run through that channel. It is estimated that there is enough power going to waste to supply Ireland and Scotland for miles around with power for all purposes. Our map gives a good idea of the magnitude of the undertaking. The scheme includes among other things, the building of a double track street railway across the isthmus. A million acres of prime land would be recovered. Convict labor would be employed on the construction. The time required would be three years. This is the plan of the civil engineer and speculator J. C. King, who estimates the cost at \$15,000,000.

BALTIMORE street railways paid a license fee of \$5 a car as follows: City Passenger, 134; Traction Company, 132; City and Suburban, 95; Lake Roland, 38; Central, 30.

PRESIDENT KILGOUR, of the Cincinnati Consolidated after watching the pushing and hauling of a piece of his rolling stock by the train crew in a vain effort to get it on the track again, said mildly to the conductor, "Why don't you use your switch hook to guide it back to the rail?" The man turned sharply, saying, "What the devil do you know about it?" "Oh, nothing," said the president, "except that I'm an employe of the company." Shortly afterwards the man discovered Mr. Kilgour's identity. He is now civil on all occasions.

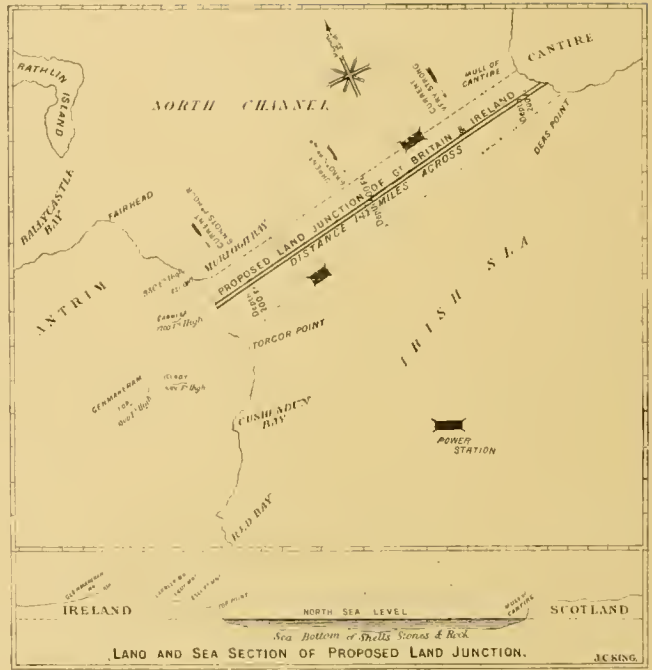

THE Brooklyn roundsmen, in a competitive examination for sergeancy, gave some queer answers to the questions. One of them who has been on the force for several years was asked what was homicide. "It is where a man is ran over by a trolley car and doesn't know it," was the reply which he gave in writing. Another one declared that it was a combination of arson and highway robbery. Still another insisted that it was assault where one man throws a bucket of water over another.



GRANITE AND STONE MATERIAL FOR BUILDING ISTHMUS.

PROPOSED SITE OF POWER HOUSE.

PROPOSED TERMINUS OF ELECTRIC RAILWAY.

## THE ELECTRIC RAILWAY AS A PHILANTHROPIST.

The Opinion of an Engineer, Manufacturer and Student of Social Problems.

While political economists and philanthropists are studying for means to obviate the evils consequent on the building of great cities and the crowding together of population, the electric railway is quietly going to work and solving the problem. We have pointed this out many times before, and prominent thinkers are beginning to realize this factor of modern city life. Thomas D. West, a prominent manufacturer of Sharpsville, Pa., recently read a paper on "Suburban Homes for Workingmen," before the Civil Engineers' Club, of Cleveland, in which the subject was treated very thoroughly. The following is an abstract of the most important parts of the paper.

The greatest bulwark that can be thrown up to protect civilization is to make it possible for the working classes to feel and know the comforts of a home. How can we expect anything but ignorance and anarchism when our social system will permit and often compels men and women to be housed by the dozen in two or three foul rooms, and there live more like animals than human beings? Volumes have been written upon the subject of homes for the poor, and the best plans for model workingmen's tenement houses, etc., but their adoption in this country is only to be deprecated. Were there no available land adjoining our cities and towns we might sanction plans for pushing to dizzy heights or dragging out an existence in the damp excavations of the earth. But many years will have passed ere it will be impossible for man to find room for a comfortable home in a suburban lot near our business sections.

The writer's last three years' experience as a manager and manufacturer, moving from city to village life, has proven much to him in practically illustrating the desirability and advantages of a suburban home for the workman. We have in our employ men that two years ago came to us from city life, that could not save a penny had they thought of doing so, but the same men are now, with about the same wages, on the road to soon own a good house and small farming lot upon which they have found profitable employment during the many "shut downs" we have had during the last nine months. My observation during the business depression we are now recovering from, in comparing the unemployed of crowded cities with those of the small towns and villages, where conditions admit of the workman possessing a gardening allotment, goes to fully prove the desirability of the system this paper advocates.

The plan proposed is that of having a well paved road leading out from two to ten miles from the city. On or near these roads have elevated or other reliable rapid transit facilities with stations every quarter mile. This highway and its vicinity would be lined with workingmen's homes.

One aid to advance good suburban homes would be the selection by every city and town of some one popular country road, and have the land along it laid off in allotments of, say forty to fifty feet frontage by from three to four hundred feet deep. Such lots would give workmen, according to their needs, sufficient ground to cultivate about all the vegetables their families might require, and with farming sections not far from their homes, it can readily be seen how cheaply they could live and raise or procure stock to supply themselves with all the fresh products of a dairy farm.

An opportunity for such suburban homes would surpass all previous efforts to elevate the workman. Many would question whether the amount of suburban travel in some districts would be sufficient to pay the interest on capital necessary to build and operate an elevated road. Where there is good reason for such doubts then of course the ordinary electric street car plan could be used.

The running of rapid transit cars being very objectionable on some roadways, it is suggested that a space in the rear of the lots be devoted to this, and the highway crossings raised or lowered.

For the economical transportation of fuel or heavy products to and from the suburban resident or farmer, the rear allotment system for rapid car travel presents many advantages over the elevated road, as switches could be laid from the main line, on the ground, at almost any point and not interfere with teaming, foot or bicycle travel, or require truss or bridge work to transfer such delivery.

In connection with the rapid transit road, an elevated bicycle roadway is suggested, which would be a source of income to the company, and obviate the necessity of paved roadways in the newer districts.

The purport of the plans here presented in nowise means to advise all workmen fleeing from the heart of our towns and cities to locate themselves in outer thoroughfares, as such would be almost like lifting up a city and moving it to some other locality. The plan advocated might be said to be more of a safety valve to prevent dangerous or unnecessary pressure upon the inner circle of our crowded towns and cities, and commence the inauguration of a system whereby we could enjoy the privileges of city life and still be miles from them, and not be compelled to crowd into unhealthy hovels and dungeons that many are found existing in to-day in order to have cheap rent.

Some would at this point raise the question of economy of residing at great distances from points of trade and employment, and argue that car fare would more than overbalance any cheapness in rent that might accrue from living in a suburban home. The number of workmen existing in our cities to-day are in the minority that do not lay out just about as much for car fare in travel for themselves and families as they would were their homes five to ten miles further away from their places of employment.



4. Ascertain number of trips, headway and running time.

5. Arrange the trips in the time table so that the work will be equalized and the platform days' work will cover as few hours as possible.

6. Special passenger memoranda should be taken of the different holidays of the year."

The general rules are good for almost any line of any size, and coming from Mr. Jewell's ripe experience are worthy of close attention.

Thus it may be seen that an elastic time table is necessary. On the Chicago City Railway the trips are divided into straight runs, swings and trippers, according to conditions. On most lines a "fall back" of twenty minutes is allowed for meals, which is counted in the day's work. A platform day's work on the Chicago City is from nine to ten hours for train men running two cars and ten to twelve hours for single cars, "split" or consecutive.

The mechanical part of the method used by Mr. Jewell, is shown in our engraving of an excerpt from the Indiana avenue line which is worked by horse and connects with the Wabash avenue cable. The line is two and two-third miles long. The line is operated with one-third less drivers than conductors. The starting point is half a mile from the barn. When the table in full is shown, each driver can tell at a glance with which car he is to connect at Wabash avenue.

Schedules for train crews are hung in the different barns from which the crews obtain reporting time. The time table is made elastic by means of the laying time at the end of the route. This serves several purposes, but is particularly useful in case of blockade or sudden access of traffic, as an equalizer. A starter is placed at each terminus of main lines who is governed by time table except in case of blockade. Starters are also placed at branch points.

Extra cars may be cut in or out, as traffic demands, in such a manner as to equalize the increase or decrease of work among the regular crews. It was by this means that the dedication crowds of October, 1892, were handled with the regular train force, although double the amount of passengers was carried.

The Sunday traffic, pleasure traffic, theater traffic and, in fact, all unusual burdens are divided and carried upon the lines and by the plan set forth.

R. S. STIKEMAN, on retiring from the Milwaukee Street Railway Company's engineering staff, was presented with a gold watch by the employes of the construction department.

W. J. FAWCETT, of 846 Fifth avenue, Pittsburgh, Pa., having retired from active street railway management, offers his services as representative of supply companies for West Virginia, western Pennsylvania, western New York and Ohio. Mr. Fawcett's large acquaintance among street railway men will undoubtedly be effective in this line of work.

## THE WINTERS CAR BRAKE.

A new car brake applicable to any form of lever or ratchet movement has been devised by David Winters, a street railway employe of the Pueblo, Col., city railway lines. The plan is, in short, a friction clutch operating against a friction plate fastened inside the flange. The clutch is supported by the axle which revolves inside the sleeve of the clutch. This sleeve is kept constantly oiled. Two chains are bolted to the sleeve, one above and one below. The friction rim is fastened to the wheel and is a separate part of the device. When it is desired to brake the car the clutch is thrown in on the axle by means of the ordinary brake lever or ratchet handle and the arms of the clutch press against the friction rim. This immediately tightens up the chain and pulls the lever of the ordinary brake. The chain is attached to the brake beam, so that no change of the style in use need be made. The mechanism simply performs the work of applying the brake. The clutch is carried only a quarter of an inch from the friction plate on the wheel when the brake is off, so that very little exertion

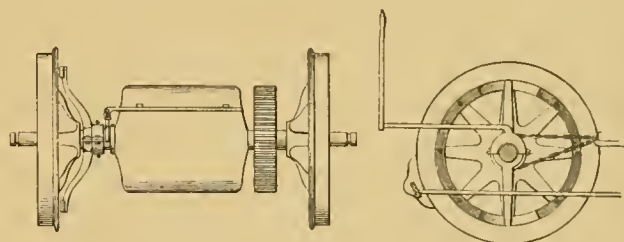

on the part of the motorman sets the brake as tight as may be desired. When a gradual stop is wanted, a mere touch will begin to slacken the speed and this may be increased as much as is necessary. The chains do not wind around the axle sleeve but are bolted at the top and bottom, so that only a quarter of a wheel revolution is required to apply the brakes hard enough to slide the wheels. Our engraving shows this attachment of the chain and the means of connecting it with the brake beam. In the same figure the friction plate is seen. Figure 1 shows the clutch on the axle carrying a motor to illustrate the small amount of room necessary for the device.

As will be readily seen the idea is not to create a new brake but to make a new, positive clutch attachment for applying any style of brake. In short, the clutch performs the function of the brake cylinder on air brakes.

The Pueblo street railway has made tests of the appliance, and General Manager H. E. Chubbuck is greatly pleased with the mechanism and will apply it to all his cars.

ALEX. B. ALLAN, of Glasgow, Scotland, has resigned from the salesmanship of Geo. Cradock & Co., Wakefield, England, the great cable making firm. Mr. Allan will sell cables for a Glasgow firm.

## A CAB-OMNIBUS.

Of all the queer methods of transportation invented or devised by his Ubiquity, the rapid transit crank, is the "cab-omnibus" shown in our engraving and launched upon the public's notice by the Glasgow, Scotland, Evening Citizen.

The engraving explains the idea of a two-horse Hansom cab of gigantic size, capable of seating ten passen-

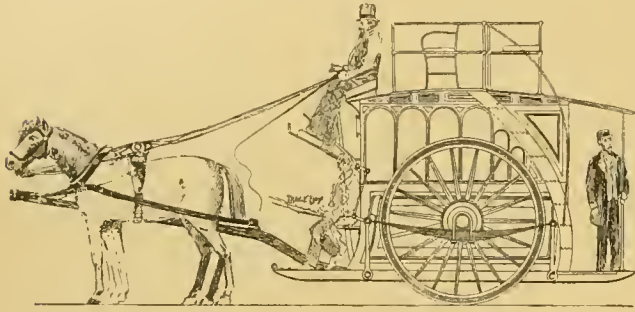

gers inside and eight outside, besides the driver and conductor and "trace boy" for using the extra horse on grades. Pneumatic tires, strong springs, and good workmanship are proposed, and the vehicle is to weigh 3500 pounds empty, and three tons with passengers. The main advantage claimed for the scheme is its adaptability and speed.

## LIKE LOTS OF OTHERS.

(We often wonder why the street railways proposed for Podunk and other large centers of from 200 to 500 population are not materialized. The following from a Brocton, N. Y., poet explains it in verse:)

Bold Owen P., he said, said he,  
"I'll form a combination  
And we will run a street car line  
Down to the railway station."

Then all the people laughed and said  
He'd better save his money;  
It wouldn't pay him one red cent,  
Which wouldn't be so funny.

But Owen said the thing he lacked  
Was just the right of way;  
If only this could be obtained  
He'd start the cars in May.

'Tis May, and cars run every day,  
With trailers on behind;  
You ask why you cannot see them—  
They're all in Owen's mind.

—PENNYSON.

RUSSELL HARRISON, of Terre Haute, Ind., recently fell afoul of the ministerial alliance of that city on account of keeping the street railway resort open to Sunday pleasure seekers. The alliance tried to stop the Sunday business, but the park commissioners and the populace stood by Mr. Harrison as did the daily papers. The consequence is that the park will be open Sundays.

## GEORGE K. WHEELER, E. E.

One of the oldest young men in the electrical field is George K. Wheeler, of the western department of the General Electric Company, whose services began with the earliest application of commercial electricity and the end is not yet.

Mr. Wheeler was born at Boston, Mass., July 21, 1861, and received his early education in that city. At the age of 18 he entered the telephone business, then in its infancy, and followed it to commercial success and the assistant chieftainship on the Boston Exchange and the management of the New England Exchange.

When the Thomson-Houston Company entered the railway field, Mr. Wheeler became associated with it as constructing engineer in the railway department. His first assignment was the Boston and Cambridge line, in which a difficult draw bridge was electrically and successfully equipped. After this, the South Side Street Railway, of Cleveland, was built by him for Tom L. Johnson. After these lines had proved successful, Mr. Wheeler constructed the lines at Newport, R. I., the West End, of Boston, and the Brooklyn & Coney Island, of Brooklyn, N. Y., besides other railways at Nashville, Tenn., and Utica and Rochester, N. Y.



GEO. K. WHEELER.

His distinguished success in these lines led to his appointment as chief engineer of the Railway Department of the Thomson-Houston Electric Company, at Chicago, embracing its entire western territory, and he has filled that position also

for the General Electric Company for the past four years. During that time, and under his personal supervision, there have been 3,059 electric cars equipped and put into operation over 1,912 miles of road, and he has also supervised the entire construction of a number of railways throughout the western territory. He is further known as manager in the following capacities: President of the Dubuque Light & Traction Company, Dubuque, Iowa; president of the South Side Railway, Kansas City, Mo.; general manager of the Citizens Street Railway Company, Kalamazoo, Mich., and general manager of the Ottawa Electric Railway, Ottawa, Ill.

Mr. Wheeler's remarkable record makes him not only a pioneer but a leader in the advancement of electric traction.

CITIZENS of Los Angeles, Cal., who own dogs, apply to the city council for an ordinance to compel the street railway company to carry the canines free. Heretofore fifty cents per dog has been the tariff.



**EXPRESS AND FREIGHT AT HORNELLSVILLE, N. Y.**

The progressive management of the Hornellsville, N. Y., Electric Railway Company, of which C. H. Wickham is the superintendent, finds freight and express business both profitable and convenient. The profits come from hauling goods for other people, and the convenience is found in using the freight car for road bed repair work.



FREIGHT GONDOLA.

be carried. It is called number 11. The railway company receives a percentage on all the express, and up to date the returns have been satisfactory.

The express carried, is that of the United States Express Company, between Hornellsville and Canisteo. It is billed out and received by the express company, so that no separate blanks or forms are in use by the railway company. A special car, however, is provided of which we shown an engraving. The car is a closed 16-foot trail car, with wide side doors for the admission of the goods to



BAGGAGE AND EXPRESS.

Car No. 20, is a gondola for heavy freight, such as brick or lumber. This car has hinged sides 12-inches high, so that it can be transformed into a flat. Doors in the bottom admit of its use for carrying and dumping ballast. The carrying of repairs for the road is no small convenience.

A special messenger is employed by the railway to collect for and solicit freight business, and the returns have been eminently satisfactory. The consignor and consignee, load and unload the goods.

THE Albany Street Railway Company, of Albany, N. Y., reports for the last quarter in 1893: Gross earnings, \$102,534; operating expenses, \$64,462; net income, \$17,945.

**DECLINED, WITH THANKS.**

We had occasion in a recent issue to make unfavorable comment on a device in which an impractical inventor is trying to interest street railway managers. We have just received what the writer evidently considers a flattering offer on his part, and which reads thus:

"If you will kindly reconsider your criticism, and make comment in a more favorable strain in our interest in your valuable magazine, and send me a marked copy, I will agree to subscribe for it."

**GAS MOTORS IN GERMANY.**

Gas motors are in regular service at Neufchatel, Switzerland and Dresden, Germany. At Neufchatel, there is an interurban line connecting with St. Blaise, a distance of three and a half miles. The estimates were made on the basis of one car each way every half hour. Each motor car carries twenty passengers, weighs, loaded, about six tons, and costs \$2,856. Gas is furnished from the city mains and compressed to 6 atmospheres. The gas costs \$1.09 per thousand, and the cost per car mile is 2.9 cents. At Dresden, Luhrig gas motors, built by the Gas Motor Fabrik, at Deutz, are used on a street railway three miles long. The Luhrig car seats six passengers, weighs seven and a half tons, and costs \$4,000. One charge of gas will run the car eleven miles. Gas supplied from the street mains is compressed by a stationary gas engine. The motor is capable of hauling one trailer.

**THEIR OWN FAULT.**

A Pittsburg clergyman preached a sensational sermon on people and corporations, and commenting on Stead's book, quoted liberally from the contents of many chapters, and indorsed with special force what was said on street railways. "Mr. Stead remarks," said the speaker, "that the overcrowded condition of the street cars reminded him of a scene in Dante's Inferno. We in Pittsburg can sympathize with what he says on this subject. It is disgraceful and unnecessary, and often so excessive that it is no unusual thing for modest women to be insulted under cover of the general push and scramble. I have heard of a number of cases where women have complained of the liberties that were thus taken with them.

"We Americans are a good natured and long suffering people to stand these things as we do. They would cause no end of trouble in England, where the people are well versed in the art of grumbling. We who do not understand it should be glad that we can get an Englishman now and then to come over here and grumble for us."

All of which sounds very plausible, but what are the facts? The female contingent of street railway patrons, especially, seem to exercise no judgment whatever in using the cars. With great unanimity they insist on

crowding the first car that comes along, and squeeze in, regardless of the protestations of the conductor that another vehicle is close behind with plenty of room. We have seen this time and again, but the American public seem inoculated with an insane desire to "get there," and the one or two minutes delay, which would insure room, seats and comfort, are religiously disregarded.

#### A BALTIMORE COLLISION.

Car Number 28 of the Central Electric line, Baltimore, is possessed of an evil spirit, or perhaps it was only hungry. As it was at the top of the Lanvale incline recently, the trolley wire broke, which in falling stunned the motorman. The unmanned car then started on the descent, and ended the swift journey by jumping the

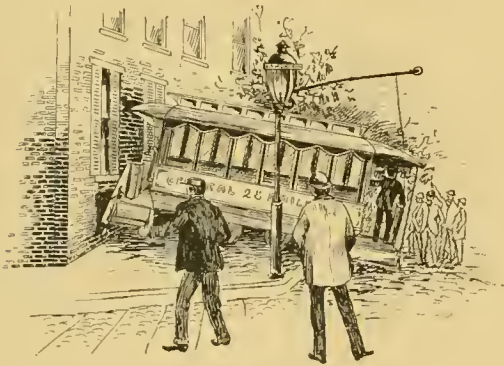

track at the curve and crashing into a dwelling. The house was of brick, but the bumper of the car and the roof went through the walls, causing them to bulge out like a balloon. The family was at breakfast, which matutinal meal was measurably interrupted by the advent of the car. The damages claimed by the house owner amount to \$2,000, and the car suffered \$250 worth. The house owner had his suit filed by twelve o'clock the same day. Truly, the trolley is waking people up in Baltimore.

#### NEWSBOY NUISANCE IN NEW YORK CITY.

The Broadway Company has at last been forced to do what many other large roads have already found inevitable, the forbidding newsboys to sell on the cars. The edict has gone forth, and thereupon the daily World enters a vigorous protest. The Recorder, however, replies in words of good common sense, as follows:

"If it be right to sell papers in the cars, if the companies were to permit their patrons to be annoyed by these little chaps, why not peddlers of candy, soap, shoe strings and bananas? Months prior to the promulgation of that order, public attention was time and again called to the abominable nuisance, not of an occasional newsboy, but of swarms of them. The Broadway cars in special, which are overcrowded, passengers outrageously incommoded at certain hours in the day, were the chief sufferers along that line. Repeatedly I have known thirty newsboys to jump on and off a crowded car between

City Hall Park and 21st street. Seven at least in every ten sold no newspaper, in spite of their pushing with great difficulty through the crowded passengers, stepping on toes and leaving odorific evidence of their passage at that. It is to be hoped, in the interest of the community in general, that the companies will adhere firmly to their rule."

#### THE MIDDLETOWN & GOSHEN GOES.

The interurban electric railway connecting Middletown & Goshen, New York, was put into commission May 7, with great eclat. The initial trip was made with a distinguished party of city officials and street railway men on board the cars. The occasion was gracefully ended by a magnificent banquet with a number of speeches from the most distinguished guests. The line has every prospect of a good business and will soon be extended. The officers of the road are: James C. Hinchliffe, president; Merle J. Wightman, vice-president and electrical engineer; W. B. Rockwell, general manager; and E. G. Wightman, secretary.

#### WATER PROOF COAT FOR WALLS.

The following process will, according to Architect and Building, make a water proof coating for walls. The process consists of covering first with a solution of Castile soap in water and then with a solution of alum and water, repeating the process until the walls are impervious to moisture. The solutions are,  $\frac{3}{4}$  pound soap to one gallon of water and  $\frac{1}{2}$  pound alum to four gallons of water. The walls should be clean and dry, and the surrounding temperature below 50° Fah. at the time of application. The soap wash should be applied boiling hot, and a froth formed on the wall. It should remain twenty-four hours before the alum wash is applied. The alum wash is put on cold. The alum and soap form an insoluble compound.

#### AND THEY FOUND NO FLIES ON HIM.

The conductors on the Oakland, San Leandro & Haywards Electric Railway, of Oakland, California, have an unusual run. A number of different fares are collected on the line for various distances, and to facilitate collection a bell punch is used.

For some time past it had been suspected that some "knocking down" had been going on. The registers were found correct enough, although examined at the beginning and end of each day. Inspectors were put on the line, but the men "inspected" them before they inspected the men. It was finally concluded that the dishonest men among the conductors opened the punches and abstracted the tell tale slips. But how to catch them was the question. Finally, a bright detective hit upon the plan of imprisoning an able bodied house fly in the punch, so that if the case was opened during the day the fly would escape, and by its absence inform the company

of the dishonesty. All the punches were, therefore, loaded with flies one morning and taken out by the men. And in the evening of the same day the punches were turned in, and in nine punches a fly was shy, and upon whomsoever no fly was found the same was given a vacation, the end of which is not yet.

A RECOMMENDATION.

An electric railway in New York state, about to be commissioned, was deluged with applicants for conductors. All sorts of recommendations were advanced by the would be fare takers, but the most unique was from a young man, who explained that he "had never been a conductor, but had often rode on the cars."

A RAILWAY ON THE ICE.

When the ice comes down the Neva River, at St. Petersburg, Russia, most of the bridges have to be removed. This is in the autumn, and when the ice gets thick enough, the bridge traffic is not resumed, but in its place is instituted an ice railway, as shown in our engraving. The Neva is at places four hundred yards wide, and an inclined plane furnishes the motive power and the cars are hauled back again by machinery. The trip requires fifty seconds and costs one cent. The cars run at 3-minute intervals,

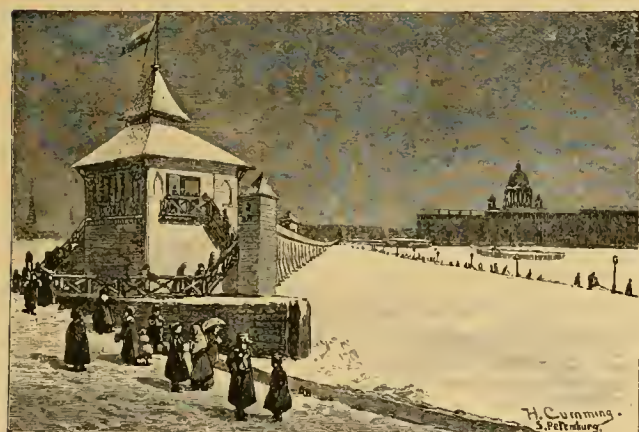

RAILWAY ON THE ICE.

and are filled all day long by passengers whose necessity or pleasure takes them over the frozen stream.

Two laborers were repairing a natural gas main in Pittsburg, recently, and the product was escaping at a lively rate when an electric car came along and the flash from the wheels ignited the gas, burning the men seriously.

AN IOWA DECISION.

In the case Des Moines Street Railway Company vs. the City of Des Moines, Ia., the Supreme Court of the State reversed the decision of the lower court. The action grew out of an attempt of the city to compel the Street Railway Company to remove its tracks temporarily from the center to the side of the street in order to allow the city to put in a sewer. *Held*: That the compelling order was unlawful. The opinion continues: "It is well settled that a municipal ordinance 'must be reasonable, consonant with the general powers and purposes of the corporation, and not inconsistent with the laws or policy of the State,' and that the courts may declare void ordinances and by-laws which are not reasonable. An ordinance is unreasonable if it be partial, unfair or oppressive in its effects, as by imposing a serious burden without adequate cause." And such, the court decides, was the order to remove the tracks of the Des Moines Street Railway.

ELECTRICS IN ENGLAND.

Commenting on the Tramways Institute at Manchester, last month, the Electrical Engineer, of London, says editorially:

"Altering from horse to electric traction means the expenditure of additional capital, and the question at once arises, will the increased expenditure bring increased returns upon the total capital expenditure? If it does not, what is the advantage of the change? If it does, the advantage is at once seen, and conviction of tramway interests on this point will soon put the required capital in the hands of managers. If a line does not now pay, the question will be somewhat different, and assume the shape of, can it be made to pay by the alteration? The inability to pay dividends is generally from lack of passengers, and it is difficult to see how one form of traction will increase the number of passengers to any large extent. While, then, we regret the want of progress in electric traction in this country, we cannot be blind to the reasons which have made tramway managers cautious. From the humanitarian point of view, horseflesh in traction work should be abolished; but nowhere in the world's history have commercial undertakings been carried out from this point of view. No one who understands horses can for one moment ignore the fact that traction work is perhaps the most killing that horseflesh is subjected to, and would gladly see inanimate materials used in its place. Those, like us, who have advocated and do advocate the use of electric traction, advocate such use because from figures put before us, from our knowledge of the possibilities of electricity, we firmly believe that its use would in most cases where it is proposed lead to increased returns, the increase being proportional to or even greater than indicated by the increased capital outlay."

"It is difficult to see how one form of traction will increase the number of passengers to any large extent."

No such difficulty exists in this country, and a careful study of results here should quickly dispose of the "difficulty" elsewhere. Just as the superior advantages of steam cars makes possible a passenger business impossible to the stage coach; or the ocean greyhound induces travel unknown to slow sailing vessels, just so the electric and cable car create a business which can never come into existence with horse cars. The saving in time; the larger and better cars; the riding for pleasure only:—any one of these advantages insure increased revenue, as certain as day follows night. It would seem to us, at this distance, that the great bar to electrical progress is in the uncertainty as to how long a corporation may hope to own and operate its property, and that the Nemesis of a municipal purchase, which to some extent must necessarily prove a confiscation, more than all other causes combined, is what serves to make capital reluctant to take the risk of expensive installation.

### THE RIDING GALLERY AS A RESORT ATTRACTION.

The advantage of some cheap, constant and diverting amusement for summer resorts is acknowledged. But what amusement? There is one that seems never to lose its charm for children and young people, city or country, and that is the merry-go-round. To improve the primitive and make it hold its interest, the Armitage-



Herschell Company, North Tonawanda, N. Y., has put upon the market the steam riding gallery represented in our engraving. It has an outside diameter of 40 feet and is built in the strongest and most durable manner. A steel cable about the periphery in direct connection with a portable engine furnishes the motion. It is readily adjusted and strongly fastened in every particular. The horses represented have a galloping motion and other stationary seats are placed at intervals. No supporting rods are in the way of the riders. The manufacturers furnish an organ and a large strong tent. The riding gallery is undoubtedly one of the best and cheapest amusement within the reach of the manager of small or

medium sized pleasant resorts. The electric railway in particular has an advantage in such an arrangement, as an old motor may be pressed into service in place of the portable engine and the power derived from the railway circuit. Where nature has not afforded boating or other passive exercises, the riding gallery makes a substitute of infinite value. In connection with evening excursions and round trip pleasure rides, and in many other ways which circumstances may suggest to the thoughtful manager, this specialty of the Armitage-Herschell Company will be a valuable adjunct.

### DIDN'T WANT TO SOBER UP.

He boarded a Fort street car at the city hall, says the Detroit Free Press, and had to stand up and hang to a strap on account of the crowd. He didn't look like a man with much curiosity, but that's where they sized him up wrong. When the conductor came for his fare the man observed:

"Con-conductor, I'd like to talk with you for about half—for about half an hour."

"Fare, sir—no time for talking!" replied the official.

"But I want to talk to you on the sub—subject of 'lectricity. I want to know how the old thing works. F'r instance, what would——"

"Here's your change!" interrupted the conductor, as he passed out.

"No time to talk, eh?" mused the passenger. "Well, mebbe somebody else has. Shay, ole man, I want to ask you a question."

The "ole man" was a solid looking business man, who was reading a paper. He looked up in an annoyed way, and replied:

"Well, what is it?"

"This car runs by 'lectricity, don't it?"

"Yes, sir."

"Takes powerful current?"

"It does."

"Current sometimes slips off the wire?"

"Perhaps so."

"Well, shir, what I want to know is this: 'Spos'n the current would slip off the wire and hit me—what would be the effect?"

"It would sober you up in about two seconds!" was the placid reply.

"Honest Injun?"

"Yes, sir."

"Much obliged. I allus kinder thought she was dangerous to fool with, and now I'm sure of it. Lemme git out! I don't want to sober up and I ain't goin' to be where the current can hit me if she slips off! Shtop 'er, conductor—shtop 'er back end of 'er car and let me drop off and walk! Shober me up! Not any! Cost me sixty cents to git zhis jag on and wouldn't shell it f'r a dollar bill!"

THE Charter Gas Engine Company, of Sterling, Ill., has a new 22-horse-power traction engine.

**WHARTON'S WOODEN FACED BRAKE SHOE.**

The engraving represents the idea of Wm. Wharton & Co., of Philadelphia, of a wooden faced brake shoe which they claim is cheaper and wears the wheel less than other forms of brake shoes. The wooden blocks, which are fitted into iron hangers, are made of oak cut across the grain, thus presenting the most durable and



effective surface for friction. The manufacturers carry patterns of these shoes for all standard trucks and have samples of the shoe which have run 6,000 miles. The use of wooden faced shoes is by no means a new idea, but in the former patterns the braking force was always with the grain instead of across. The simple method of attachment to the iron hanger and its capability of quick renewal will also be noted in its favor.

**BUFFALO'S BUSINESS.**

The report of the Buffalo Street Railway Company for the quarter ending April 1, shows: Gross earnings from operation, \$267,135; operating expenses, \$168,541; net earnings, \$98,193. For the same quarter last year there was a net loss of \$9,598. The Crosstown Street Railway, operated by the same company, shows: Net earnings, \$24,435; fixed charges, \$22,050; net income, \$2,868. For the same time last year there was a net deficit of \$7,890. President Watson and Manager Littell should rejoice.

**HAY PAVING BLOCKS.**

We have frequently seen pies that were better suited for manhole covers, and biscuits which would certainly have done faithful service as paving blocks, but it has remained for some ingenious crank to suggest the use of hay for paving purposes. Engineering News says: "Compressed hay for paving is reported to be under trial by the Amies Pavement Company of Philadelphia. Under heavy pressure in a Dederick hay press, the dry grass is pressed into cubes and then cut into paving blocks of convenient size. After being soaked in a drying oil it is claimed that the blocks become indestructible."

**THE SONG OF THE "GRIPMAN."**

" You may talk about your hermits' caves,  
Far off from human jars,  
But there's no place for a misanthrope  
Like the Broadway cable cars.  
Oh, with the folks a-standin' up  
I like to play my tricks.  
And see them knock each other down  
Just like a row of bricks.  
I'll start so quickly that they'll fall  
And butt against the door;  
While dignified old gentlemen  
Sit down upon the floor.  
And when they smash each other's hats,  
And scream, and swear, and groan,  
I'd not change places with the king  
Who sits upon the throne!"

—N. Y. World.

**BELTS AND BELT SPLICING.**

F. W. Salmon, writing on the above subject in Power, gives the formula for belt glue used in splicing: 1 pound pure water, 1 pound 2 ounces of clear white glue, 1 ounce of isinglass, to which when hot and thoroughly mixed is added 3½ ounces alcohol, ¼ ounce of white shellac, ¼ ounce sulphuric ether. Sometimes 1½ ounces of dry white lead, or 1 ounce powdered pumice stone, are added to give body to the mixture. This glue should be applied hot to the well scraped laps of the belt to be spliced. The joint is then well hammered with a wooden mallet and clamped firmly until the glue has set.

**BROOKLYN'S TROLLEYS AFFECT L ROAD'S REVENUE.**

When people must travel do they prefer a surface or elevated transit? Do the so-called "dangers" of rapid transit electric and cable cars deter the many from investing nickels in rides to and from business or pleasure? Is elevated transit with steps to climb and stops at stated intervals pleasing to the average citizen? The L roads of Brooklyn, with a sorrowful sigh, say No! The people of Brooklyn, with one accord, say no, and the proposition so stands. Not many months ago the REVIEW showed the falling off in receipts of the Brooklyn elevated lines. This deficit was directly attributable to the electric cars then new. The sequel is that Anthony Barrett, president of the L, has decided upon extensive retrenchments to make up for the loss "on account of the encroachments of the trolley lines." Wages of employes are consequently reduced and all the night platform men discharged. The New York Times says:

The trolley system commands the local transit situation. The increase in traffic on the electric lines surpasses the most extraordinary expectations of the management. The crowding of the cars is not confined to the so-called "rush" hours, when passengers are going to and from their business. It is particularly noticeable in the forenoon during the time set apart for shopping. Along Fulton street and Flatbush avenue, in the retail dry goods district, it is not unusual to see seventy or eighty cars so close together that they resemble a "solid" train. The demand for seats is so heavy that the rolling stock in use supplies it insufficiently. At the present rate of development the railroad companies will have to largely increase the number of cars.

### COL. SINCLAIR AS A BOND SELLER.

When Col. Wm. H. Sinclair sallies forth to do anything the usual custom is for him to succeed. It was thus with the floating of \$1,000,000 of bonds for the Galveston, Texas, Street Railway Company, of which Col. Sinclair is president. These bonds, which were sold to New York parties, will be used in retiring the company's outstanding obligations and in paying off the floating indebtedness. This will consume half of the money thus obtained, while the rest will be used in rehabilitating and reorganizing the service of the road by introducing electricity and rebuilding almost the entire line. Col. Sinclair has the utmost faith in Galveston's future, and he rarely makes a mistake. "With improved terminal facilities," says Mr. Sinclair, "Galveston will be the metropolis of the great southwest."

### THE SMALLEST STREET RAILWAY TOWN IN THE WORLD.

How many people does it take to support a street railway? Will the class in rapid transit please step forward? That is a delicate question.

Here comes an answer from North Carolina, not only from Carolina North, but from Carolina High, in fact from Hendersonville, 2,400 twelve-inch feet above the level of the Atlantic ocean. There the Hendersonville Street Railway Company has builded, to the best of our knowledge and belief, a street railway, in the smallest town supporting such a modern contrivance.

By reference to the directory of street railways at the beginning of this volume will be found the following:

**Hendersonville, N. C.**—Hendersonville St Ry  
Co. Pres Supt & Pur Agt S V Pickens, 1¼ m, 4-3¼  
g, 30 lb. steel T r, 2 c, 1 h, 2 m.

What it does not say is that Hendersonville has only 1,800 people within its borders, and that the one-and-a-half miles of track are at an elevation of 2,220 feet at the lowest point, and rise to 2,350 feet before the end of the mile and a half is reached. Nor does it say that S. V. Pickens, president, vice-president, superintendent and purchasing agent, is one of the most whole-souled men in the south, a lawyer, and a North Carolina prohibitionist. All of this is true, however from a to z.

Yea, and more.

The Hendersonville Street Railway has a franchise for 99 years! To be exact and truthful, Mr. Pickens does not conceal the fact that three of the ninety and nine have expired.

Asheville is twenty-two miles from Hendersonville, and may be reached by the Asheville and Spartanburg Railroad. Summer tourists are numerous throughout this region, and Hendersonville has the best of facilities for caring for the invalid and pleasure seeker. It is situated on a table land ten miles square, and where the town stands it is almost as level as most of Chicago. It seems surrounded by mountains of from 600 to 1,000 feet in height above the table. The town has its own water

works, made by building a reservoir, for a deliciously cold and clear mountain stream, and at the same time getting a natural head of 300 feet.

The street railway runs up the main street, passing all public buildings, theatre, churches, and the domiciles of seven-eighths of the inhabitants. The rolling stock is in first class condition, and the motive power is well cared for by the humane superintendent. Every visitor to North Carolina should not fail to ride up the Hendersonville street railroad, nor miss meeting the genial genius of the enterprise.

### AN EXPLOSION IN CHICAGO.

It will take several fares to repair the damage done to the stone sidewalk of the North Chicago Street Railway Company's offices by a terrific gas explosion on the night of May 16. Leaking gas caused the ruin, igniting from

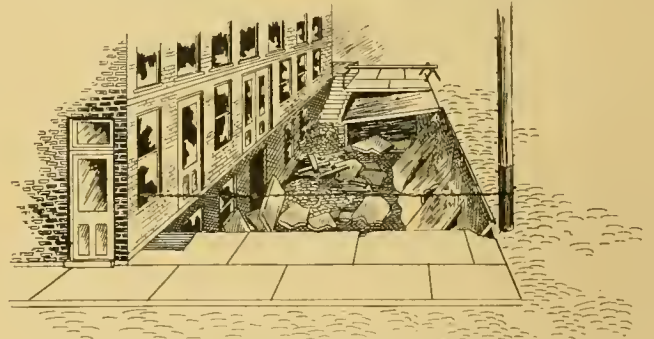

SIDEWALK IN FRONT OF GENERAL OFFICES.

a workman's lantern. The huge flag stones were lifted clear of their foundations and plunged into the subway. No damage was done to the cable or cable conduit and no one was hurt. The damage to the buildings and pavements was \$5,000.

### FUEL OIL AT AURORA, ILL.

Pending the settlement of the miners' strike, and consequent coal famine in Illinois, the manager of the Aurora Street Railway Company, D. A. Belden, has begun the use of petroleum for steam making. No particular system of burning has been adopted, but two well known burners were purchased and connected up on a plan of Mr. Belden's. It consists in simply piping live steam to each burner with a pump, to maintain the pressure at twelve pounds. There is no tank for reserve supply, but the oil is taken directly from a tank car on a switch track in front of the boilers. Mr. Belden says that had he been using lump coal the oil would have given a distinct and appreciable saving. Streater screenings, at \$1.10 per ton delivered, was the fuel in use, however, with special grates, so that tests must be made to determine the relative economy of oil. Two men in the boiler room are dispensed with under the new plan. As a convenience during the coal strike the idea was commendable, and we await the outcome of the tests.

THE NATIONAL SCHOOL OF ELECTRICITY.

A national school of electricity has been organized recently in this city, the object being to form a class under a competent instructor, in every town in the country where the population will justify it. These classes will be held weekly and the course will be forty weeks. The plan if carried out ought to prove a benefit to street railway employes and indirectly to employers. The honorary faculty comprises thirteen prominent electricians. The officers of the corporation are J. P. Barrett, city electrician of Chicago, president; J. L. Little, vice-president; E. L. Powers, treasurer; J. Allan Hornsby, Monadnock building, Chicago, secretary.

C. T. SNEDERKOR, of the home office of Washburn & Moen, is on a few months trip through Europe.

THE WHEELING, W. VA., ELECTRIC LINES.

REVIEW readers will remember an interesting account of the Bellaire, Bridgeport and Martin's Ferry interurban which appeared in the December, 1893, issue of this magazine. It will not be without interest, therefore, to those who are watching the remarkable progress of interurban lines and the sure growth of trunk electric railroads to hear further of railway development in this growing section of the valley of the Ohio. Just across the Ohio river from the scene of our former story is the metropolis of the section, Wheeling, W. Va., a city of modern enterprise, historic worth and electric railway possibilities. Wheeling has now a population of 40,000, with seventeen miles of street railway whereon to ride. The Wheeling Railway Company, which operates the above-mentioned track, is the result of a history.

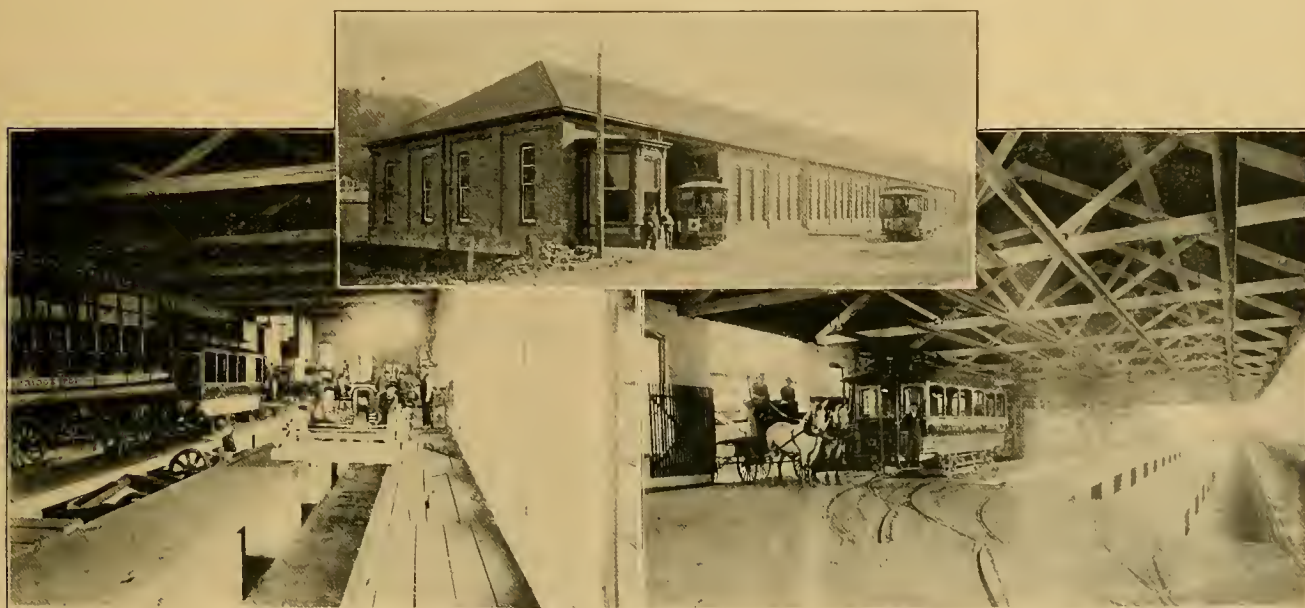

CAR HOUSE—WHEELING, W. VA.

THE TRUE INWARDNESS OF THINGS.

The Buffalo Times has evolved a wonderful idea and says:

“Strange that it has never been thought of until now! One of the latest inventions in steam power is that of making the grate bars of furnaces hollow, and fitting them with water pipes, so as to utilize for creating steam a great deal of heat which is wasted in the ordinary grate. Nothing strange, though. We have been trying to have the street railway companies have hollow rails made through which hot steam might be forced to do away with the snow nuisance, but they will not do it.”

Another equally good advance would be to make the trolley wires hollow through which the current can pass without exposure to the rain and snow.

THE weather during the past month has necessitated an almost daily change of equipment.

This is the history:

The Citizens' Street Railway Company was incorporated in 1863, and operated in 1867. Until 1887 it was run as a horse line, when the Wheeling Railway Company was organized, which, together with the Citizens' Railway Company, adopted the Vandepoele system of electric traction. It was thus one of the first four street railways to adopt electric traction.

In 1892, a Cleveland and Cincinnati syndicate purchased the line and the Citizens' Railway Company was leased by it. Since then the system has been operated as the Wheeling Railway Company, of which John J. Jacobs was president until his lamented death in November, 1893.

During the years 1892-93, the entire system was rebuilt and re-equipped from the double to the single trolley system. Seventeen miles of new rail also was laid, all 85 to 95-pound girder type.

The power station, a well-equipped and substantial

structure, contains three Abendroth & Root Manufacturing Company's boilers of 270-horse-power each; four General Electric dynamos of 100-horse-power each; one Westinghouse generator of 270-horse-power, and three Ball, cross-compound, high speed engines of 250-horse-power each. The arrangement of the machinery gives most efficient disposition of space and its condition speaks well for the management.

The car equipment consists of 25 St. Louis Car Company's cars and 15 of other make, each having two 15-horse-power General Electric motors. The cars are models of comfort and elegance and the motors give satisfaction.

The roadbed is carefully planned and substantially built, and the excellent service is rewarded by increased and increasing traffic.

The geography of the surroundings is best explained by reference to any good map. The distance from Wheeling to Benwood is four miles; Bellaire is directly across the Ohio; Bridgeport is one mile from Wheeling,

the Ohio river, one being a suspension bridge, and two bridges crossing the back channel. One of the bridges crossing the main channel and both of those crossing the back channel are used by the railway company. The one directly opposite, connecting Wheeling with Bridgeport, is extensively used, more so on account of the railways entering there, the upper bridge being used by the railway company in operating its cars to Aetnaville and Martin's Ferry.

The personnel of the company is: President, Hon. Wm. Erskine, a prominent Wheeling lawyer; C. F. Dickinson, B. S. Allison, J. C. Palmer, Jr., and W. R. Kimball, directors; W. A. Shirley, secretary and treasurer, A. M. Jolly, manager.



THE WHEELING POWER HOUSE.

THE Menominee Electric Light, Railway & Power Company, which was at one time considering the matter of putting in a storage battery as an auxiliary to its central station, has given up the plan and put in additional machinery instead. Battery makers seem to be unwilling to guarantee definite results.

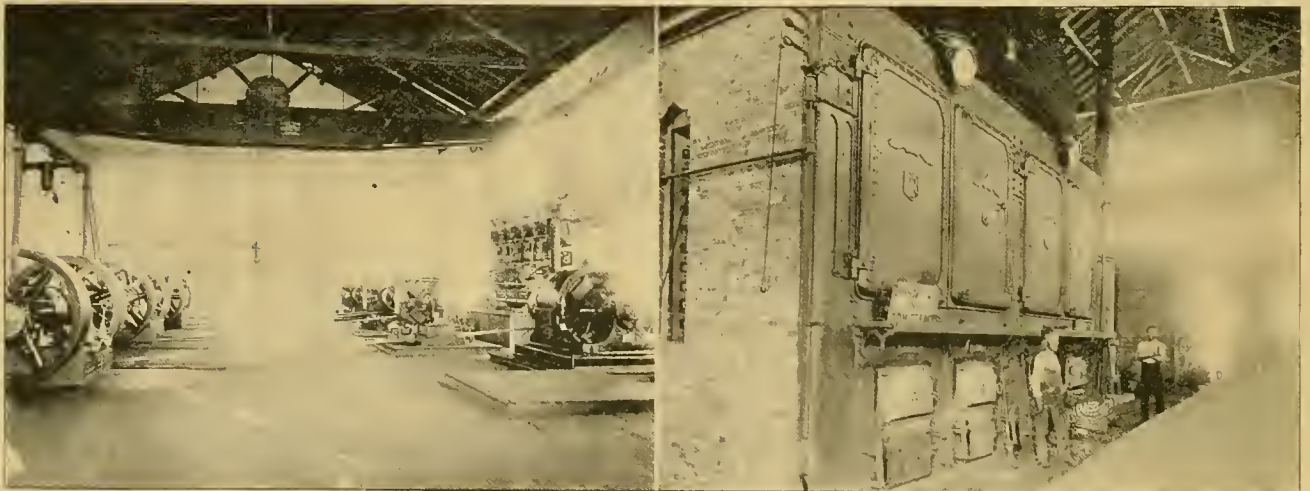

INTERIOR VIEWS WHEELING POWER HOUSE.

Aetnaville two miles, and Martin's Ferry four miles. An island in the Ohio, opposite the city, has become a favorite residence spot and now has a population of 7,000. It is one and a half miles long by half a mile wide. The surrounding towns are feeders to the extent of the following population: Benwood, 10,000; Bellaire, O., 25,000; Bridgeport, O., 15,000, and Martin's Ferry, 15,000.

There are two bridges crossing the main channel of

CHICAGO conductors are noted for their honesty. Recently the West Side Street Railroad Company received from one of its conductors inclosed in an envelope a \$2 bill as a contribution to a conscience fund. A note accompanying it read: "My conscience hurts me. I failed to ring up some of the fares I collected. I could not sleep for thinking over it. I believe the inclosed \$2 will make us about square. May God bless you. May he guide me aright hereafter."



## THE SAME EVERYWHERE.

The daily press of the country delights in constantly keeping the public in mind of fatalities which occur in connection with the operation of street cars, and of late years electric and cable cars particularly. As we have frequently shown, the great majority of these accidents are purely the result of no less than criminal carelessness on the part of the victim.

In London, where there are practically no street cars operating on the surface, one would naturally expect there would be scarcely an accident in the streets. The following from the Pall Mall Gazette therefore dispels the illusion and ranks the London cabbie as a more dangerous engine of destruction than the deadly trolley ever dreamed of being:

"A correspondent has called our attention to the alarming increase of human slaughter in the more crowded thoroughfares of London. He complains that there is no sort of supervision over drivers of public vehicles. Even a conspicuous badge is no longer insisted upon, and many of the drivers have no license to show. And he wants to know whose fault it is that the hackney carriages act is not enforced. We suppose it is the fault of the police, who have full power to exact competency and reasonable care from drivers. But at the same time we are bound to say that in our experience both cab drivers as a whole and the constables who regulate traffic are well enough up to their work. But that may be because we have never been slaughtered in the street ourselves."

## WHERE CIRCULARS GO.

"Newspaper advertising is all right in its way," said a young business man recently, "but we new advertisers do not stand much show. When I give an advertisement to a trade journal, it is placed among others of its class, and is overshadowed in importance by those of older and better known firms. With circulars it is different. Each stands upon its own merit, and the best wins."

Not long after this conversation, says a writer in the Inland Printer, I stood in the postoffice of a busy country town, awaiting the distribution of the mail.

A man, who was afterward found to be the proprietor of one of the leading stores of the place, came in and opened a lock box. He took therefrom a goodly quantity of mail, piece by piece, and, after glancing at each, tossed a number unopened to the floor.

When asked for his reason for doing so, later in the day at his store, he said: "I have been in business twenty years, and have in that time received so much advertising matter through the mails that I can almost tell a circular by a glance at the envelope, whether sealed or not.

"What I am not sure I will be interested in I do not take time to open. I miss it sometimes, you will observe," with a glance at a partly filled waste basket, "but not often."

This incident was an actual occurrence, and it shows

that, while good results may be obtained from a judicious use of circulars, they can hardly be regarded as being sufficient unto themselves.

## GRANDMA'S POEM.

(At a public meeting at Brecksville, O., to encourage the electric line to Cleveland, the following "poem" was read. It may be said to contain more truth than poetry).



Don't you hear the street car coming!  
 Don't you hear the "ting-a-ling"  
 Over the hills and through the valley;  
 That's the bell; just hear it ring.  
 Horse cars do not suit our times,  
 sir—  
 We know of a better steed;  
 Don't mark us as "hayseed fogies,"  
 We will ride at lightning speed.

And our produce for the market,  
 We will send it every day;  
 Berries that are just delicious  
 We will grow, for it will pay.  
 Berries fresh with dews of morning  
 We will to our cousins take,  
 Ere they eat their early breakfast  
 In the city by the lake.



Cows will now be worth the keeping;  
 Jersey cream and butter fine  
 We will send to you in town, sirs,  
 Send it by the motor line.  
 Four quarts of milk will make a gallon,  
 As it did long time ago;  
 And we'll send our friends in Cleveland  
 Milk on which the cream will grow.

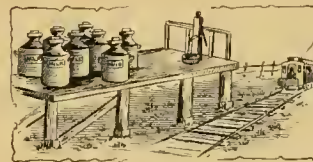

Futile all our plans were proven,  
 If we thought to ride to town;  
 Horse and buggy both were ready  
 But the rain came pouring down  
 Then the roadway was so muddy  
 We perforce must paddle through  
 If this day we reach the city;  
 I don't like it, friends, do you?



And again the icy snow storm  
 Oft prevents the ride to town,  
 And the thought of play or lecture  
 Leaves on many a face a frown.  
 But the street cars now are coming;  
 That's the bell, just hear it ring;  
 O'er the hills, and in the valleys,  
 Listen to the "ting-a-ling"



Step aboard now, and be sheltered  
 From the rain and winter's cold,  
 And from fervid heats of summer;  
 There is room for young and old  
 Horses are too slow to suit us,  
 Lightning must obey our will;  
 We are traveling with the times,  
 sir,  
 Don't think we are mossbacks still.



**BRUNER'S BRICK FILLER.**

For the purpose of paving to any type of rail, H. C. Bruner, of Pontiac, Ill., has devised a series of molds for brick, to be made in such shape that they may be used with any pavement. The idea is very simple, as the engraving shows, namely, that of a brick molded to fit a girder rail. It may be made also to fit a T or center bearing rail as well. The idea is a good one, and no doubt will materially decrease the expense of wood fillers along street railway track.

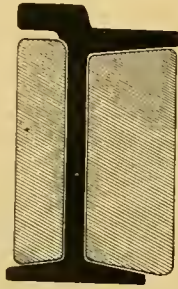

**DA MONK ESCAPED.**

The Allentown & Bethlehem Traction Company, of Pennsylvania, has an unique summer resort of which a feature is a menagerie. Recently a carload of new animals was brought in. Among them was a long tailed monkey. This interesting beast squeezed through the bars of his cage and went for the tallest tree in the grove. The entire force of the street railway, assisted by the population of Manhattan village, rushed to the task of capture, and finally lodged Mr. Monkey where he belonged, but not before more than one pair of trousers had suffered at his paws.

**REINCARNATION OF ELEVATED BICYCLE RAILWAYS.**

The bright, new ideas that inhabit the inventive mind frequently have prototypes in your Uncle Samuel's patent office that throw a shadow of suspicion on the said bright, new ideas. This is especially true of radical

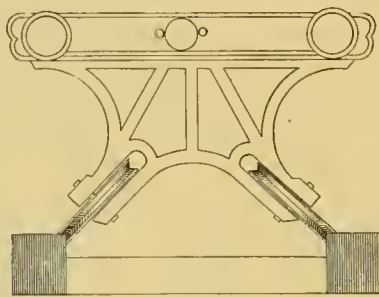

departures so often floated through the daily lay press as panaceas for the rapid transit evils (?) of our parlous times.

In the Scientific American for December 25, 1845, nearly half a century ago, there appeared the plan for an elevated bicycle railway as sketched in the engraving. The inventor claimed that the scheme was particularly adapted for wooden rails "thus saving the great cost of iron." The two wheels seen in the engraving are set at an angle of 45 degrees and act only as guides, the car wheels being flat rollers and running on the square wooden rails also shown. The account of the invention

says that a system of this order was in process of building at Wimbleton Common, England, and the American remarks, "If the invention succeeds, and we see no reason why it should not, it will lead to the introduction of wooden rails on many short railway lines from village to village or to manufacturing establishments." The Meigs elevated railway plan shows several points which seem to parallel this ancient plan. Perhaps the perusal of old patent reports by inventors of our day would be productive of a number of other "new ideas."

**THE AUTOGRAPH RECORDER FOR POWER STATIONS.**

Quite a novelty in the way of a station recording instrument is being introduced by the New National Time Recorder Company, of Milwaukee. Figure 1

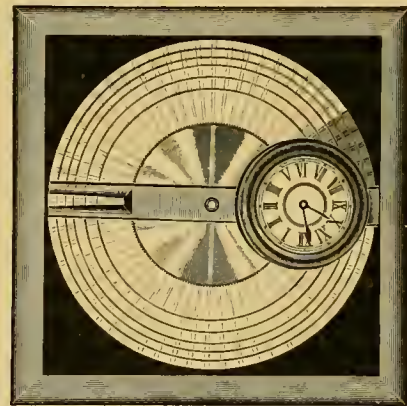

represents the device, which is 17 inches square. A small section of the dial is shown in Figure 2. The dial is 15 inches in diameter and when in operation is covered by plate glass with the exception of an opening through which the engineer or dynamo tender can write his signature and also the record desired. By referring to Figure 2 it will be seen that the record dial is divided by parallel radial lines into 30 minute spaces, so that a record

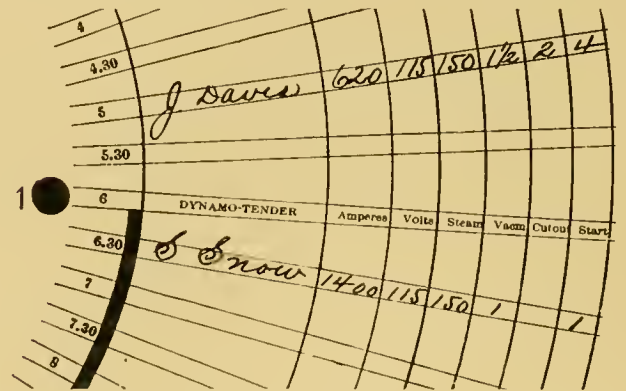

can be made every half hour of the amperes, volts, steam pressure, vacuum, dynamos cut out and dynamos started, which records are separated by concentric lines. The heavy black line is the night line and represents the time from 6 p. m. to 6 a. m. Figure 2 shows a record made

at 5 p. m. by J. Davis, the day man, and a record made at 6:30 by S. Snow, the night man. The dials are made to cover a space of 30 hours, so that in case whoever keeps the records does not always change the dials at a certain hour each day, there will be six hours lee way. In using this recorder it is absolutely necessary that the employe should make his record at stated intervals, otherwise that portion of the dial where the record should have been made will have passed away from the slot and will be unaccessible. It can be fastened on the wall or laid on a desk, as preferred, and it will keep good time in either position. It is readily adapted to other business by simply changing the printing of the dials.

**A PURELY ARTIFICIAL PLEASURE RESORT.**

Although we have, in a previous issue, fully described the resort built by the Urbana & Champaign Electric Railway Company,

we can not refrain from again calling attention to the success of an undertaking which seemed so unpromising at first. With nothing but a corn field to start with, and the public ridiculing the idea of making a pleasure resort in a country, treeless, riverless and as level as a floor, the company began late last spring to get the corn field in shape, and in spite of the fact that last year the park bore a very crude and unfinished appearance, the public patronized it to such an extent as to nearly swamp the street railway. This year a professional amusement manager and two theatrical assistants are employed. Admission to the park is free. Theater seats are 10, 15 and 20 cents. The success of this undertaking should be a lesson to those who are



◀ CHAMPAIGN ▶  
On the Afternoon Train, if You Want a Jolly Holiday.

**ADMISSION FREE.**  
**OPEN FROM MAY 1 TO OCTOBER.**

Amusements of the Highest Character. Ladies and Children Especially Invited.

**GREATEST SUMMER GARDEN IN THE STATE.**

Eight Acres and Eleven Buildings, Covering Over 40,000 Square Feet.

**Great Switch-Back Railway.**

Band Concerts. Theatrical Attractions.  
Bowling Alleys. Shooting Galleries.  
Base Ball and Sports. Dancing.

Arc Light-Stereopticon.  
Photographs Taken at Night.  
Refreshments.  
Free Swings and Tennis Courts.  
Magnificent Illumination.  
Settees, Canopy Tents, Flower Gardens,  
Shelter, Shade and Water.  
Perfectly Lighted by Electricity.

**MOST IN QUANTITY!**  
**BEST IN QUALITY!**  
**LEAST IN PRICE!**

**SPECIAL ATTRACTIONS WEEKLY**

**Florence Miller's**

**Great Burlesque Co.,**

**25—PEOPLE—25**

**The Whole Week—April 30 to May 5.**

**PARK FREE.**

**Theater Seats, 10-15-20c.**

You never saw a Better Show at Five Times the Price. Reduced Fare on all Railroads during the Entire Week.

without natural parks in the vicinity. The accompanying actual size reproduction of one of the numerous advertisements sent out gives a good idea of the attractions at the park and is suggestive as to what others can do along the same line.

**THE STILWELL RAILROAD JACK.**

The Stilwell-Bierce & Smith-Vaile Company, of Dayton, Ohio, has put upon the market the car jack shown herewith. The frame is very stiff and of malleable iron, the rack and pawls of forged steel, and the bearings of

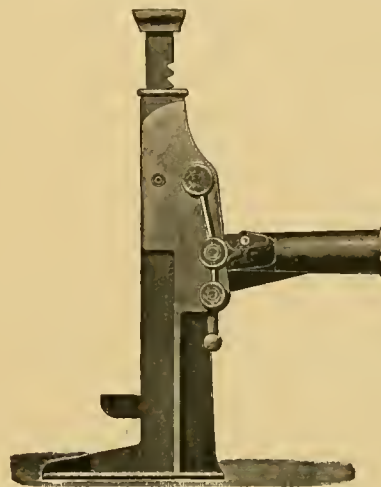

machinery steel. The load may be carried either on the foot at the base or on the upper end of the bar. The load, by the arrangement of the pawls, may be raised half or full notch, but is absolutely still during the downward movement. The jack is strong, rigid and reliable.

**THE GIANT SAFETY COLLARS.**

These collars, which are made by the Gouverneur Machine Company, of Gouverneur, N. Y., are manufactured in both solid and split forms. They are chambered to avoid unnecessary weight upon the shaft, but in such manner as to preserve full bearing surface at each end.

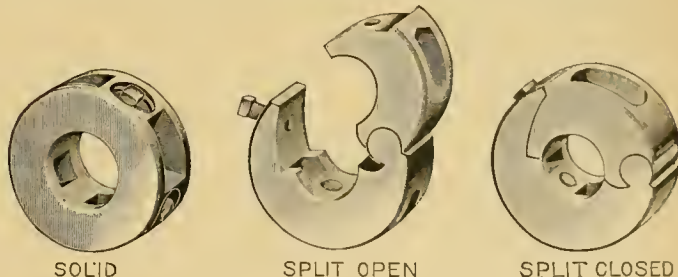

SOLID

SPLIT OPEN

SPLIT CLOSED

The split collars have a hinge joint and may be put upon the shaft in a space equal to their length. When in place the set screw that holds the collar together also secures it in position on the shaft. No bolts are used, and the set screw heads do not project above the surface. They are attractive in appearance, and contain sufficient material to give necessary strength where required, useless weight being avoided.

### THE ARNOLD SYSTEM OF ENGINE AND GENERATOR COUPLING.

The well-known street railway and electrical engineer of Chicago, B. J. Arnold, has designed a system of engine and generator connection which offers a saving both in real estate and first cost over the approved method of plant construction at present. It is now generally considered that a plant, to have the highest efficiency consistent with reliability, must consist of three units, two of which are sufficient to carry the maximum load, while the third is held in reserve. Thus one-third of the plant is lying idle constantly. The Arnold system gives a part of the reliability of three units with but two. As the system of clutches necessary to do this costs something, the saving in investment is not equal to the cost of the third unit,

shaft. The hollow shaft is then coupled to generator Number 1 by energizing the coil N. Thus both generators are run from one engine. The low pressure cylinder of the engine is run as a high pressure in order to give the necessary power to run the two generators. This is, of course, an uneconomical and temporary arrangement, but is only necessary when repairs are being made. In case the magnetic clutch is not used, a mechanical one will serve the purpose, although it can not of course be changed over so readily. A possible form of mechanical clutch is shown above the magnetic clutch in the engraving. The station can be enlarged indefinitely by adding on units at one end or the other of the two already installed, thereby increasing the reliability of the station, in that one engine can be connected to four generators.

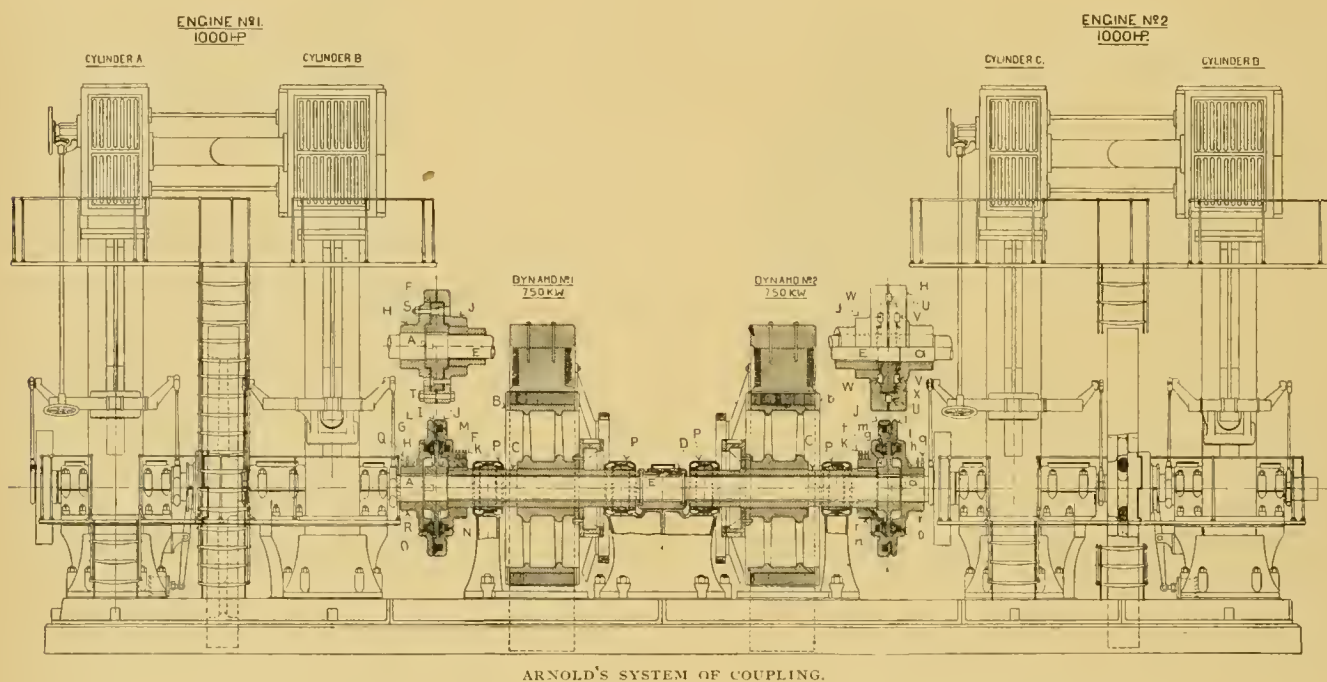

ARNOLD'S SYSTEM OF COUPLING.

but the inventor estimates the saving over the three unit plant at about 20 per cent. The plan is to have the two generators mounted side by side with their shafts in line and with the engines at each end. The generator shafts are hollow and are independent of each other and of the engines. They revolve in the bearings P, p. Through these hollow shafts runs another shaft, not touching the generator shaft in any way, but supported by the bearing E in the center and kept in line by the cone points at each end. In the disks, which are on the ends of the generator shafts, there are magnetizing coils M, m, which, when energized, attract the wedges I, i, on the corresponding engine disks and form a clutch coupling so that each engine drives the generator nearest it. Meanwhile the inner shaft is idle and there is no more friction or wear than in any direct coupled plant. Suppose now, engine Number 1 breaks down. The coil o of the disc on the shaft of engine Number 2 is energized, which has the effect of coupling engine Number 2 to the hollow

### ROBINS FENDER TEST.

The Robins fender has been tested in Philadelphia recently on a car of the Electric Traction Company. Men and boys sat down gracefully in it with the car going seven or eight miles an hour when it struck them, and finally it became so that the "children cried for it," and begged for a chance to be picked up by the device. If the accounts of the test are correct, the fender seemed to answer the requirements of such a device, as far as saving of life is concerned.

THE Patton motor has reappeared in Chicago and a car of this type has been plying for several days on 67th street, between Cottage Grove and Stony Island avenues. W. H. Patton, the inventor, says that a company to be known as the Patton Independent Motor Company, with offices in the Old Colony building, will put it on the market.

### BEAVER'S BALL PARK.

The enterprising management of the Beaver Valley Traction Company, of Beaver Falls, Pa., realizes the value of induced traffic to the extent of arranging at the expense of money, time and trouble, two beautiful popular pleasure grounds, known as Junction Park and Grand View Park.

The site selected for the former was midway on the line of the Traction Company and a mile and a half above the confluence of Beaver River and the Ohio. It contains twenty-six acres of level ground, and what nature and history has not accorded the Traction Company has added to its interests. Within the enclosure of Junction Park is laid out a base ball diamond, a foot ball field and a tennis court. A bicycle course is also prepared and a half mile driving track is arranged for next season. For the accommodation of the patrons of the park a grand stand has been erected. This will seat 1,000, and six tiers of "bleachers" have been placed for the comfort and convenience of a thousand more. Dressing rooms for the participants in the



H. P. BROWN.

It will be mainly a picnic ground, and the excellent natural advantages, coupled with the care bestowed upon it by the Traction Company, make it an ideal place for families and schools as well as for small parties to spend a bright summer day amid the handiwork of nature. Beaver Falls in itself is a worthy object of visit, redolent with the early history of the great commonwealth of Pennsylvania and the Indian wars. Here, too, was the basis of the treasonable operations of Aaron Burr, whose overweening ambition to found an empire in the Southwest territory resulted in his fall and flight.

The officers of the Beaver Valley Traction Company are John M. Buchanan, president; Theodore P. Simpson, vice-president; Stephen P. Stone, treasurer, and Hartford P. Brown, secretary and general manager, whose foresight and earnest efforts have resulted in the increased traffic of the system and to whom we are indebted for the material of this sketch.

### AN ANCIENT PNEUMATIC CONDUIT RAILROAD.

In the Practical Engineer of England, G. A. Sekon tells of a six mile pneumatic railroad, built in 1845 between Forest Hill and Croydon. It was worked by a piston in a cylinder or conduit between the rails. The air was



BEAVER FALL'S PARK.

games and tournaments, refreshment stands and ticket offices, are also provided.

The actual opening of the park was arranged for April 25 and a "combined show" brought out a crowd of 4,000. The formal opening was May 12 with a ball game. Since then, base ball has been the attraction, and the dates are closed until far into the season. The business of the line has been so good that next season more extensive preparations will be made for public entertainment.

Grand View Park, at the Northern terminus of the line, is now open for the reception of pleasure seekers. The site has many natural advantages, such as caverns, springs, towering rocks, shady groves and lovers' lanes.

exhausted in the conduit in front of the piston. A slot in the conduit which was self closing enabled connection to be made between the car and piston. As impracticable as the scheme appears on its face, the fact remains that the road was run and a speed of seventy miles an hour attained. The conduit slot had leather edges and these were sealed behind the car by an apparatus which fed a sealing composition onto the slot. It would seem impossible to maintain a vacuum with several miles of such a joint, but this was done (for a time at least) by dividing the line into two sections of three miles. In 1847 the South Devon railway opened up a fifteen mile section of this kind of road. The cause of failure of this, as of the others, was the deterioration of the leather of the slot.

### THE LONGEST SWING BRIDGE IN THE WORLD.

The Omaha Bridge & Terminal Company has the honor of being the possessor of the longest draw bridge in the world. The company was incorporated three years ago for the purpose of building a second bridge across the Missouri river at Omaha, and operating steam and street railways in connection therewith. The bridge, which was completed last winter, extends from East Omaha to Council Bluffs. The East Omaha Street Railway will use it to reach Council Bluffs. The span is 520 feet and is swung by electric motors. At present there is only a double track railway on the bridge, but the trusses are provided with places for brackets to carry roadways and sidewalks. It was built by the Phoenix Bridge Company, which does a large amount of this kind of work, and has reason to feel proud of having in this case broken the record for length of draw span. A. C. Sites, the Rookery, is Chicago representative of the Phoenix Bridge Company.

connection will be made with the water pipes at convenient stop valve and fire plug boxes with a small copper plate of known weight, and placed in the moist earth close to the water pipe and allowed to remain there for a definite time, its percentage of gain or loss in weight will be a measure of the current passing to or from the pipe through the plate and into the earth at that place. As a check, a similar test piece of copper, not connected to the pipe, will be buried close to the other in such a way that it will be subject to the same conditions from action of soil and moisture on the copper which may take place independent of the electric current from the water pipe. The proper corrections are to be applied on account of the action that may be set up between the iron and the copper independent of the earth return currents under consideration. I am led to believe that by continuing experiments of this kind and keeping proper record thereof, the affected territory can be definitely circumscribed. The determination of the direction of the street railway return currents must be by volt meter and ampere meter methods.

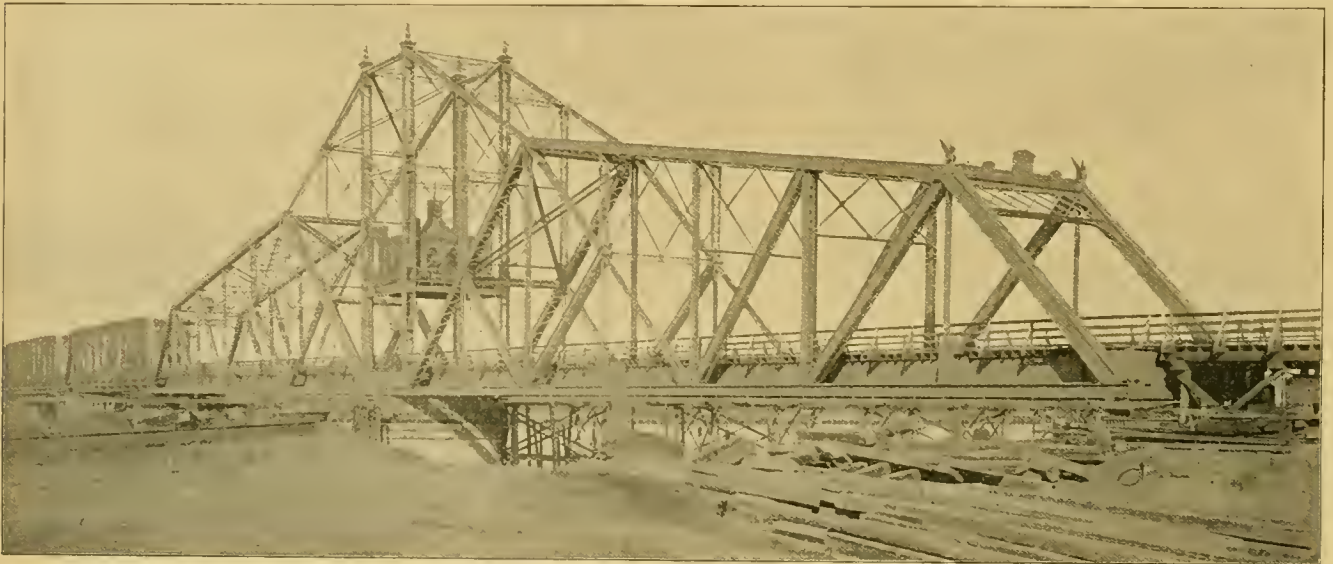

LONGEST SWING BRIDGE IN THE WORLD.

### EXPERIMENT WITH ELECTROLYSIS AT ST. LOUIS.

The supervisor of city lighting at St. Louis, A. J. O'Reilly, has recently made the following report to the Board of Public Improvements in regard to an experiment that will be tried in that city to determine the extent of electrolytic action on the water pipes.

"It being desirable to make records of the electrolysis at various places along the water pipe system of the city that comparison may be made of the relative extent to which the electrolysis is going on during a definite time in various parts of the city, and, as this cannot be done with any degree of accuracy with the instruments available for the purpose, without a great increase in the number of observers, the following method has been determined upon by the water commissioner and myself. A

### HAVE YOU HAD ELECTRIC MUMPS?

Everything is fast becoming electric, at least in name, but the very latest and decidedly original idea was developed in the courts in Louisville, where the case of Samuel H. Isaacs, administrator, vs. the Louisville Railway Company and the Ohio Valley Telephone Company was on trial.

This was a very peculiar case. Isaacs died in May, 1893, with an attack of mumps. By some means, some active attorney of the bar found out that about six months previous to the time of his taking down with the mumps that he had had a shock from an electric wire, and at once, thinking it a good excuse for a law suit, filed one against the said companies for \$10,000 damages.

After hearing the evidence the same was thrown out

of court; the administrator failed to receive any damages whatever, as it was well established that the said Isaacs safely recovered from the slight shock he had received, and it was a genuine case of the mumps that he died with.

## BRICK PAVING AT LOUISVILLE, KY.

The city council of Louisville, Ky., has recently passed a complete series of ordinances specifying the manner in which all paving shall be laid, and the quality thereof. As regards brick paving, the ordinance is complete in all details.

It provides that the street surface shall be worked to grade, and that the crown of the subgrade shall be twelve inches below the top of the curbing when set to grade.



ORDINARY SECTION.

After being thoroughly rolled and cleaned and the material approved, a six-inch bed of hydraulic cement concrete shall be laid. The formula for the cement is: One measure of cement and two of clean, sharp sand, thoroughly mixed dry, and then made into mortar with the least possible amount of water; broken stone or hard brick cleaned, drenched with water, but containing no loose water in the heap, to be incorporated with the mortar so as to give a surplus of mortar. This mixture is to be spread and rammed. On the foundation thus prepared, a bed of clean, sharp sand shall be spread two inches deep, and upon this bed the paving brick is to be laid, on edge, at right angles with the street, except at street intersections, where the board of public works may make special orders. Brick must be laid as com-

whole pavement rolled or rammed to the true section. After the rolling and ramming is completed, the joints shall be filled with paving cement, obtained from the residuum of distillation of asphalt or coal tar. Then the whole shall be covered with half an inch of sand.

Footway crossings are built three inches higher than the street. When a street railway track is laid in the street, the rails, ties and stringers shall be put in place by the company before the paving is laid, or if afterwards at the expense of the company, as shown in the engravings. Street intersections and curves shall be laid as shown in the plan. A granite liner between the brick and the rail is provided. The space between the track and directly outside is to be filled with concrete.

## NEW ORLEANS' WEST END FIRE.

Early Wednesday morning, May 23, New Orleans citizens were aroused to witness the most destructive fire of many years—a loss of \$100,000. The West End, a famous pleasure resort, consisting of the West End hotel, bar, wharf, restaurant, promenades, park, band stand and minor appurtenances thereto, was destroyed. It was the property of the New Orleans City & Lake Street Railway Company, of which H. M. Littell is manager. The establishment was well insured in twenty different home



WEST END RESORT.

and foreign companies, and the enterprising manager did not allow the total destruction of the property to interfere with the traffic, but rigged up a band stand and made the smoking ruins "the attraction."

Before the fire the place was a most popular pleasure ground, standing on the shore of Lake Pontchartrain. The hotel, with its broad verandas always in the sweep of the breeze, had a large capacity, and a magnificent view of Spanish Fort and Milnburg. Seats on the beach for hundreds of people and ample band stand room induced a large evening traffic. A new arrangement will be made by the company for next season.

THE coal famine in Ohio has led the Mineral Ridge & Niles Electric Company to adopt a clever method to secure coal. The company has had built a regulation flat car which they can attach to a motor car and haul coal from the Ridge mines to Niles. A similar plan has been adopted by the Trumbull Company.

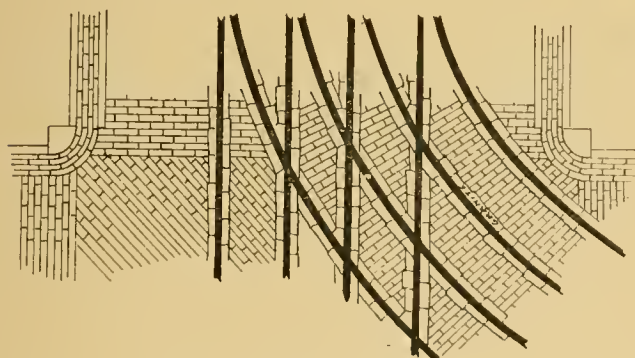

PLAN OF STREET INTERSECTION.

pactly together as possible, and all joints are broken by a lap of at least two inches. The brick must be hard burned, for paving especially, of uniform size and free from flaws. Nothing less than a half brick may be used to break joints. The brick must be burned throughout to vitrification. When the brick has been laid for a distance of sixty feet, the first fifty must be covered with clean, sharp, dry sand, which must be swept in and the

### THE INDEPENDENT TROLLEY.

The first noteworthy point about this trolley is that it has a flexible pole of seamless steel tubing. This tube is tapered from  $1\frac{1}{2}$  inches to  $\frac{1}{8}$  inches. The object of this is to relieve the hammering on the overhead construction. The weight of a 13-foot pole is 13 pounds 2 ounces. Another peculiar feature is the roller bearing swivel base. While at first this seems like an unnecessary refinement,

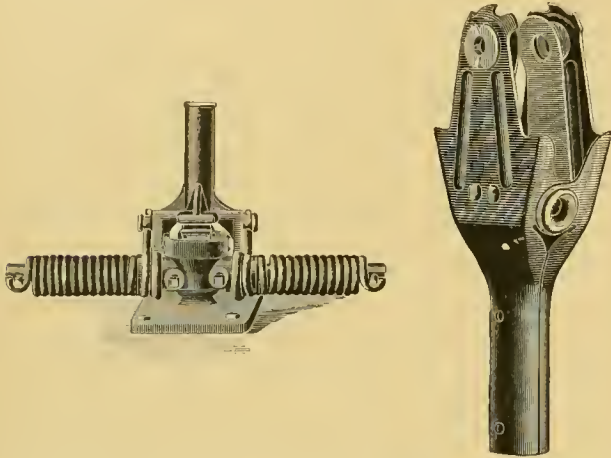

it must be remembered that the strain on the swivel bearing is enormous. The roller bearing used is similar to that used for years on grindstone axles. Torsional springs are used on the base, for the reason that they give nearly a uniform pull throughout their entire range. This is shown in the case of clock springs. This, together with the fact that gravity counteracts the effect of the spring when the pole is bent very low, goes to make the pressure almost even on the wire. The harp is pressed from thin sheet steel, and will receive any type of trolley wheel. The wheel has a hard copper hub with graphite bushing. The harp has flat phosphor bronze springs pressing on each side of the wheel. The weight of the trolley complete is 112 pounds 2 ounces. It is handled by F. Wayland Brown, Cleveland.

### LIFTING CAR BODIES.

Superintendent I. B. Walker, of the Sioux City Street Railway, has a very simple method of lifting car bodies

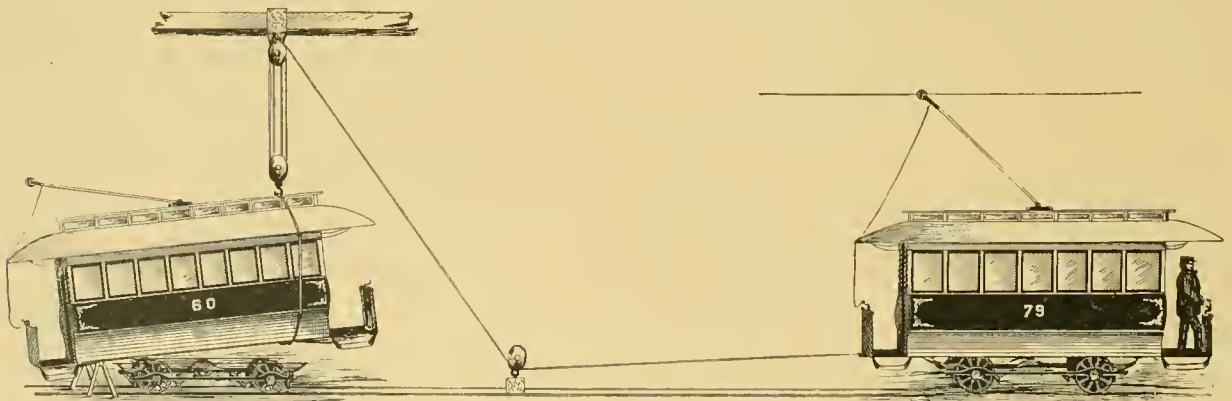

NOVEL METHOD OF LIFTING CAR BODIES.

off of trucks that is far ahead of the use of car jacks both in rapidity and first cost. It is operated on the principle of a steam railroad wrecking derrick, the motive power being furnished by a motor car running on one of the barn tracks. One end of the car to be lifted has a horse placed under it. Over the other end a large set of pulley blocks are suspended from a beam overhead. The loose end of the rope from the blocks runs through a snatch block attached to the bottom of a post at one side of the track and finally attached to the drawbar of a motor car on the same track as the car to be lifted. All connections between the body and truck are removed, the pulley blocks attached, the motor car started, and up comes the car body. When the body has been lifted enough, the brakes are set on the motor car until the car body is to be let down again. Mr. Walker says that with this arrangement a pair of wheels can be changed in a few minutes. A box car can be brought off the road and have its truck put under a summer car in two hours. The only investment required is for the pulley blocks.

### CIRCLE TO THE RIGHT.

The "belt" of the Underground Railway of London, and the "compartment" cars are responsible for the following dialogue in which an elderly woman and a young man were actors.

She:—Might I ask you, sir, to help me out at the next station?

He:—I should be most delighted, madam.

She:—I would not ask the favor, but you see I'm old and stout and lame, so I have to get out backward, and, every time, just as I get my foot upon the platform, the guard comes along and thinks I'm trying to get in, and before I can stop him he shoves me in and slams the door to, and cries out "Right away," and I've been around the circle three times!

A. W. FIELD, who resigned from the vice-presidency and directory of the Peckham Motor Truck & Wheel Company, has accepted the managership of the Boston office for the same company, a position which he held in conjunction with his former duties.



## STREET RAILWAY LAW.

EDITED BY FRANK HUMBOLDT CLARK, ATTORNEY AT LAW, CHICAGO.

*Expelling Passenger for Failure to Comply with Rules.*

Where a street car company has adopted a rule against passengers riding on the platform, a request by the conductor that persons violating the rule shall come inside the car, in observance of the rule should be complied with, whether the person had notice of the rule or not; but when he wantonly refuses to obey, the Company has the right, at once, to expel him, using no more force than may be necessary for that purpose.

This is an action in case, brought by the appellee to recover damages for being ejected from one of appellant's street cars, after he had taken passage thereon. A trial resulted in a verdict and judgment for ninety dollars.

The evidence shows that appellee took passage on one of appellant's electric cars at a time when all the seats inside the car were occupied, but when there was plenty of standing room within, and the aisle was clear. He, with three others, took position on the rear platform, when they were requested by the conductor to go inside. It was against the rules of the company to allow passengers to ride on the rear platform. The others pressed in, but appellee refused. He was several times so requested by the conductor, but each time refused, and persisted in standing on the platform. At length the conductor told him he must either go in the car or get off, and refused to go further with the car until appellee should comply. Appellee then left the car, no violence being used toward him. The conductor did not lay his hands upon, nor offer to do so.

It is difficult for us to understand upon what theory the plaintiff is entitled to damages. The rule which he refused to comply with, and because of the enforcement of which he was denied passage on the car, was established for the safety of passengers, and the convenience of employes operating the car. It was a reasonable and proper rule. He saw fit to stand out in defiance of it, evidently from sheer stubbornness, or to invite an assault from the conductor. A street car company has the right to require a passenger to observe all reasonable rules tending to promote the safety and convenience of passengers, and the successful conduct of its business. So long as a passenger observes such rules, the company is bound to carry him; but when he wantonly refuses to obey them, the company has the right at once to expel him, using no more force than may be necessary for that purpose.

Appellee contends that he had not sufficient notice of the rule. We do not think it was necessary for the conductor to have exhibited the rule, or told appellee in terms that the company had adopted such a one.

The request of the conductor was reasonable, made in observance of the rule, and it was the duty of appellee to comply, instead of standing out against it with childish obstinacy, as he did. The conductor should have control of his car, with the right to enforce all needed regulations, and all reasonable requests made by him with that end in view should be obeyed by passengers.

The judgment will be reversed, and, inasmuch as we find that the facts are such that the plaintiff has no cause of action, the cause will not be remanded.

(Illinois Appellate Court. Fort Clark Street Railroad vs. Ebaugh. 49 Ills. App. Rep. 582.)  
*Consolidation of Street Railway Companies—Original Charter—Obligation of Contract.*

Certain street railway corporations, organized before the adoption of the Tennessee Constitution in 1870, consolidated their property and franchises after the adoption of said constitution. Nothing in the constitution or subsequent acts of the legislature indicated any intention to deprive such consolidating companies of any privileges or franchises exercised under their old charters. The said constitution required all corporations to be formed in pursuance of the general laws, whereas the said consolidating companies had been organized under special charters. *Held*, that under the rule that the presumption must be that the consolidated company preserves its original charter rights and burdens intact, unless the contrary is expressed, the said corporations did not, by the act of consolidation, subject the irrevocable rights granted by the original charters to the dominion of the state; and neither the state nor a city thereof could take away from the consolidated company the right to use a certain street under a right granted by the original charter to operate a street railway "on all or any of the streets in the city."

(United States Circuit Court, Western District, Tennessee. Citizens' Street R. Co. vs. City of Memphis. 63 Federal Rep. 736.)

*Motive Power—Stringing Trolley Wires—Injunction.*

The mere fact that a charter granted to a railway company contains some provisions usually contained in special charters granted to railroad companies, such as condemnation of land, and the taking of the railroad by the state, does not require the charter to be construed so as to prevent the construction and operation of a street railway within a city, where the charter expressly confers upon the company the right to construct its railroad from some point within the city to a point without, as well as along any street of the said city.

In an ordinance of a city, consenting to the construction and operation of a railroad within the city, the words "horse railroad track or tracks," must be taken as descriptive of the railroad to be constructed, and not of the motive power to be used, when the terms "horse railroad" and "street surface railroad" have come to be convertible.

An act entitled "An act providing for the placing of electrical conductors under ground in cities of this state, and for the creation of a board of commissioners of electrical subways," provides that no electrical wire or cable shall be constructed along, across or above the surface of

any street or avenue in any city without authority from the board created by the act. *Held*, that while the general object of the law is to require electric wires occupying the streets of a city to be placed underground, the commission is authorized to permit wires to be strung in cities until such time as the overhead stringing of wires can be terminated without hardship.

Where the authority of a street railway company to string its trolley wires without the consent of the said commissioners is doubtful, the company is not entitled to an injunction restraining an abutting owner from cutting down the wires which it has placed above the walk in front of such owner's lot.

(New Jersey Chancery Court. *Patterson R. Co. vs. Grundy*. 56 American and English Railroad Cases, 486.)

*Reorganization of Street Railway Company — Assignment of Contract Rights — Using Track of other Company.*

Two corporations organized under the general laws of the state, each holding assignable street railway franchises, entered into a contract (each acting for itself, its successors and assigns) by which the first agreed to pay the second, as a consideration for authorizing it to run its cars over its track, four cents per mile for each and every mile traveled by each and every car run over its tracks; said agreement to last during the term of the charters granted to the said respective corporations, or of any extension of said charters, provided that, in case the first company shall cease to use the privileges granted to it in the contract, then, and in that case, the agreement shall be ended. *Held*, that where the first company is in undisturbed possession of the right, exercising and enjoying it every day, it cannot release itself from its contract obligations on the claim that the agreement was *ultra vires* of the powers of its officers; that where under such a contract the second company conveys all its rights, property, and franchises, specially including therein its rights under the agreement mentioned, to a third company, which assumes all the obligations of the former under the agreement, there is nothing in the assignment of which the first company can complain; the said third company having been organized by the stockholders of the second company, and for the express purpose of acquiring all the rights, property and franchises of the old company, and assuming all its obligations, and the old company having postponed its dissolution until after such transfer and *assumpsit* should have been made, the new company, for the purpose of the contract declared on in this case, was merely the old company organized under a new name.

(Supreme Court of Louisiana. *Canal & Claiborne R. Co. vs. St. Charles Street R. Co.* 44 La. Ann. 1096.)

*Injury to Child — Obstruction in Street — Construction Company — Who liable for Injury.*

In an action against a street railway company for the death of a child, it was not claimed that the city had any active agency in causing the accident, further than giving

the construction company a contract to build a sewer, and its ordinances required the construction company to so place the excavated material as not to interfere with travel on the streets or incommode occupants of adjoining property, and to observe all ordinances in relation to obstructing streets, etc. *Held*, that if the city were liable at all, it was for negligence in permitting the construction company to violate its ordinances by creating and maintaining a nuisance.

A construction company, under a contract with a city to build a sewer, made a temporary wall of the pavement blocks which had been torn from the street, leaving an aperture through which people might pass upon a foot-path five feet wide along the side of the street railway. Travelers had been accustomed to use this pathway, and did not usually cross the street railway at this point. It seems that the construction company had left the aperture in the wall for the purpose of accommodating travelers, and to avoid obstructing the street. A child, in attempting to cross the railroad, after having passed through the small aperture, was killed by a passing car. *Held*, that the construction company was not a joint *tortfeasor* with the railroad company, because it could not logically nor reasonably be maintained that there was any necessary connection between the death of the child and the work of the construction company.

(Supreme Court of Missouri. *Stanley vs. Union Depot R. Co.* 56 American and English Railroad Cases, 561.)

*Negligence of Car Driver in Frightening Team — Contributory Negligence.*

In an action against a street car company for injury to plaintiff's horses, caused by collision with defendant's car, it was held that the plaintiff was not guilty of contributory negligence in selecting the street upon which the injury occurred, when he might have gone another route, although the space between the tracks and retaining wall was narrow, and an electric railway causing noise calculated to frighten horses was being operated on that track.

The conductor on the street car was guilty of negligence in not stopping or slowing up his car, which was running at a high rate of speed, where, as soon as he came in sight of the plaintiff's horses, they began to rear and jump, and the conductor saw, or ought to have seen, in the exercise of ordinary prudence, the team, and that they were frightened.

If the driver of a wagon was placed in a state of peril by the negligence of the motorman of the street car, the company is responsible for the consequences which ensued, though the peril might have been increased by an effort made to avoid it, or might have been lessened or escaped in the exercise of unusual courage and self-possession, provided the driver used the care of an ordinarily prudent man, under all the circumstances.

If the driver of a vehicle is placed in a state of peril by the negligence of those having charge of a car, the company is responsible for the consequences, since

“a defendant cannot impute a want of vigilance to one injured by his act, as negligence, if that very want of vigilance were the consequence of an omission of duty on his part.”

(Supreme Court of Pennsylvania. Gibbons vs. Wilkesbarre & Suburban St. R. Co. 155 Pennsylvania State Reports, 279.)

**BARNEY & SMITH TRUCK.**

The new car truck manufactured by the Barney & Smith Company, of Dayton, O., is giving much satisfaction on the lines where it is being used. Oscillation is eliminated by a very liberal use and favorable combination of springs. Two kinds of springs are used. The elliptics are between the car body and frame and the spirals between the frame and car axles. Of the latter there are four sets of three springs each, one set over each journal. These springs are so proportioned and connected on the cantilever principle that a load applied at any one of the points of support is felt equally by the

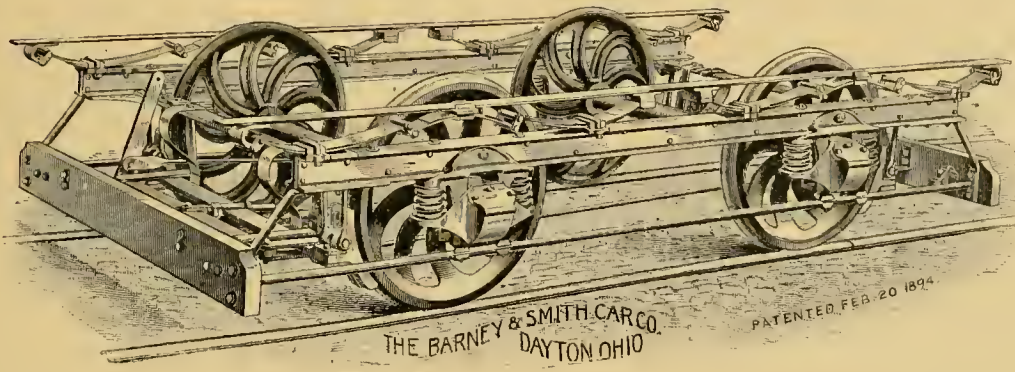

whole set, and is thus distributed over a considerable distance on both car body and truck frame. The truck frame is thoroughly cushioned from destructive vibrations. The spring base is ample to properly support the car body, being 13 feet for a 6½ foot wheel base. To hold up the ends of long open cars the truck is built to receive a set of braces which are not shown in the engraving. The frame is strong and simple. The side frames are continuous and straight. The latter feature will be appreciated by those who are familiar with some forms of built up frames. No gray iron casting enters into the construction of the frame, it being composed entirely of steel, wrought iron and malleable iron. The brakes are very powerful, with wrought iron beams and levers, and the breaking of hangers will not let the parts drop on the track nor hinder its working. The failure of one of the chains or either of the connecting rods disables the apparatus only so far that it can be applied from but one end of the car, but from that end, however, with maximum power.

THE Neville Island & Coraopolis electric railway of Pittsburg has introduced a freight service for hauling garden produce to the city.

**THE SARGENT SHOE.**

Modeled after the M. C. B. Association pattern, the Sargent Company, formerly the Congdon Brake Shoe Company, of Chicago, has produced the Standard brake shoe and head for street railway service. The standard measurements for the head are determined for the face which fits the shoe alone, as the back must be made to fit any particular kind of beam used by the railway. The measurements are almost identical with the standard adopted by the Master Car Builders' Association after long study. The advantage of standard measurement to the store keeper and to the repair shop are so obvious that no mention of it need be made here. The Sargent Company will mail blue prints, with full dimensions, to any manager interested.

THE West End Street Railway Company of Boston is declared to have a soul, by the daily press. Recently a number of its employes were burned out of their homes

by a South Boston fire. The Company immediately established the unfortunates in a new tenement, and purchased all their housekeeping requisites, besides two week's supply of groceries. Eighteen families were thus assisted.

**The Big Four Route Has the Best Terminal Facilities at Chicago.**

All trains enter Chicago on the Illinois Central tracks along six miles of the Lake Front, through the most picturesque portion of the city, and land passengers in the magnificent new Central Station on Twelfth street and Lake Front. This station is convenient to the Auditorium, Richelieu, Victoria and Leland Hotels, and within two blocks of the State and Wabash street cable lines and the South Side Elevated Railway. Convenient stops are also made at Hyde Park, Thirty-ninth street and Twenty-second street stations.

Magnificent vestibuled trains, parlor cars, Wagner sleeping cars, private compartment buffet sleeping cars and superb dining cars. No transfer across Cincinnati to make connections.

Your ticket should read via the Big Four route to enjoy these privileges. E. O. McCormick, Passenger Traffic Manager; D. B. Martin, General Passenger and Ticket Agent, Big Four Route, Cincinnati, O.

## THE SORROWS OF THE OLD MAN.

It was a summer day in Chicago. The sun was behind the clouds somewhere getting up a new meteorological disturbance, and three men had just been into the superintendent's office to offer advice on the question of open cars.

It was inventors' day.

The seventh inventor came in and turned down the fur collar of a rather battered coat. Six of his kind had run the gauntlet of the private secretary and had made their painful way into the superintendent's presence.

Fifteen others had gone away dragging their hearts along the floor, where they had fallen with an obtuse concussion of low temperature, when the young man, whose business it was to head off inventors, had informed them that this office is not an asylum for cranks or a rendezvous for experimenters. Three had been killed and thrown into the cellar in order to make their presence more seldom.

The seventh was now before a frown, for the best natured superintendent cannot hold in check the frowning propensities of his face at the sight of a model or an inventor's blue print.

"Are you the superintendent?" asked the inventor. "I am," was the reply, less stern than the frown betokened. Thus encouraged, the inventor unrolled his drawing and continued, "For years I have been greatly distressed over the great loss of life on our street railways, and it has led me out of my regular business to do what I could to allay this destruction of life. I have solved the problem, and now offer you the result of my thoughts and labor. It is a fender for your cars which will do its work perfectly in every case—the only practical, common sense fender ever gotten up."

The curiosity of the superintendent was fully aroused. Four of the preceding six who had succeeded in getting before him, had exhibited also the only perfect fender. He glanced at the drawing and it took but a moment to see that it was all the inventor claimed for it. It would do its work perfectly and absolutely. To provide against any contingency, in case the first blow did not kill, the contrivance picked the victim up bodily, pitched him several feet high and more than that broad, where, if the fall did not finish him, he was left to the mercy of heavy trucks and hurrying vehicles. "You have never been in the street railway business, I believe," said the superintendent. "No," the inventor replied, "I am an undertaker, but my experience——" and while the private secretary and the elevator boy tried to resuscitate the nerveless form of their superior the inventor drifted into the henceness and reappeared a few hours later at the office of the STREET RAILWAY REVIEW, where the religious editor listened patiently for an hour to a detailed description of the "wonder."

THE first horse-car in Buffalo, N. Y., was run in the "middle thirties," and the president and general manager was also conductor and driver.

## THE NEW ORLEANS TOWER WAGON.

The New Orleans Traction Company has designed for its overhead work a simple and efficient tower wagon, a representation of which is shown herewith. It was made by taking an old horse car and erecting above it a substantial platform, properly girded, with a ladder at one end as shown. It was moved by an old dummy engine, also a relic of pre-electric days. It is safe, convenient and cheap. The car is used as a storage for tools and wires.

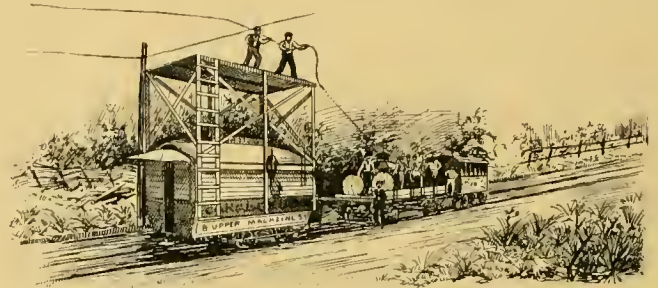

stantial platform, properly girded, with a ladder at one end as shown. It was moved by an old dummy engine, also a relic of pre-electric days. It is safe, convenient and cheap. The car is used as a storage for tools and wires.

## FREE RIDES FOR THE UNFORTUNATE.

The generosity of the management of the West End Street Railway, of Boston, is becoming proverbial. In another place we mention the kind treatment of certain of its employes' families that suffered a total loss of household goods by a fire and here we take occasion to mention that the company distributes 70,000 tickets per annum to various well known and reputable charities, such as hospitals, infirmaries and the like, for redistribution to worthy persons who may need an outing on the street cars. The tickets are not good on Saturday and Sunday, and only during the hot weather. On the reverse is this legend: "The person riding on this ticket waives all claims against the company for any accident growing out or incident to such ride."

The mayor and board of aldermen are made almoners of this interesting and generous charity. This method of gaining public approval might be followed to advantage in many other places.

## DECORATION CROWDS IN CHICAGO.

On Memorial Day the North Chicago Street Railroad Company enjoyed several advantages over the other city roads. The cemeteries of Calvary, Graceland and Rose Hill are reached by the north lines, and the bicycle road races began and ended at Lincoln Park. The receipts were between \$8,000 and \$9,000, and about 150,000 passengers were carried. The increase over ordinary traffic of the post-Columbian year was very satisfactory. The South and West Side street railways also did a good business.

JOHN FOX, for thirty-five years an employe of the Brooklyn City Railway Company, died recently at the age of 57.

## STREET RAILWAY FREIGHT LINES.

The Beginning of an Industry that Will Still Further Supplant Horses—Inauguration of a Slow but Sure Change in Our Cities.

The electric railway freight service began with the long interurban road. It gives promise at present of not only seriously interfering with the business of the farm and stage horse but entering our cities and relieving the city truck horse of some of his work.

Like other innovations it will meet with bitter opposition on the part of teamsters and the kicking public, but in places where it will pay it is bound to come. The only question in most cases is as to what extent the street railway would be able to compete with teams. In large cities, where there are many large commercial houses depending on teams, freight haulage by street railways would undoubtedly be the cheaper. In very large cities the business would have to be done principally at night.

A very important move in this direction has been made in the city of

## SPOKANE, WASHINGTON,

where the various street railway properties are controlled by the Washington Water Power Company, which concern, besides owning the water power in the city, operates a large flouring mill there. This mill was built several years ago, and owing to various causes trackage facilities by steam railways have not been extended to it and to a number of other similar industries, and so far the output of these industries has been handled by means of teams. Within the last two months the subject of reaching these industries and handling their incoming and outgoing freight by electric cars has absorbed the attention of the local property owners, and after a more or less bitter battle a franchise has been granted the Spokane Street Railway Company, authorizing the company to make connection with the steam transfer track of the Northern Pacific Railroad and to operate an electric freight car along Front avenue over the tracks on which it now runs passenger cars, terminating at the C. & C. mills, with branches from the main line reaching other mills not yet reached by side tracks, and the depots of the Spokane Falls & Northern Railway, the Union Pacific Railway and Great Northern Railway, thus giving the electric system complete connection with all the depots and railways centering in the city. As the ordinary tracks of the electric railways are used for this freight car, it was not deemed advisable to move steam cars on the tracks, especially as the curvature of the streets would have been a serious obstacle, and necessity therefore compelled the design of electric freight cars specially arranged for the cheap handling of the freight. As a result a very ingenious car was designed by the manager of the company, and was built in the company's car shop the details of which are sufficiently novel to justify full description. All grain is taken to the mills in bulk. It is brought in from the country in box cars and has to be handled into the electric cars. Temporarily this is being done by hand, but a small elevator is nearly completed, and the grain will then be moved out of the steam cars

by an electric power shovel and dumped into the boot of the elevator, which, running also by electricity, will lift the grain to a bin, from which it will flow by gravity into the freight car. The car itself is 16 feet long and 7 feet wide in the clear. It is an ordinary box car, mounted on Brill No. 13 trucks, with 6½ foot wheel base, and is equipped with two No. 8 Edison motors, which have been rebuilt in the shops, so that the maximum speed with 30-inch wheels is now six miles an hour. In outward appearance the car is like an ordinary freight

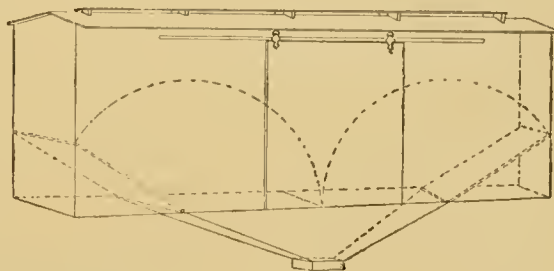

car, except that there is a hopper under the middle. In the center of the floor over the hopper are two trap doors, opening up from the center and swinging back against the ends of the car. When the traps are down the car has a level floor. When they are up the car is transformed into a huge hopper, of which the hopper under the car forms only the lower part. The principle is easily seen from a glance at the accompanying sketch. At the spout of the hopper is a steel gate. When the car is loaded it is run down to the mill, where it passes over the mill sink, the hopper spout of the car coming, when the car stops, immediately over the aperture of the sink. The steel gate is then drawn, and in less than a minute the contents of the car gravitates into the mill sink, and from thence finds its way into the mill elevators for grinding. The hinge floor of the car is thrown down to the center and the load of flour dropped into the car ready for transfer to the steam cars, by which it is shipped to China or Japan. The car at present used in the work carries about 250 bushels of wheat in a trip and a similar quantity of flour out. A larger car of the same design is now being built to carry 10 tons at a load. In the month of February the car handled in 230 hours, running between the dry kilns and the mill, some 64,000 bushels of wheat. This work was performed by one man, and a boy acting as trolley boy. The car has been on the road now for three months, and has never been to the shops for repair. In handling the output of the mills there is a piece of line of 900 feet of 5 per cent grade and a 55 degree curve with 4½ per cent grade, and the car travels up these curves smoothly and rapidly. The car has been found exceedingly convenient for delivering macadam along the road between the rails. Macadam is loaded into the hopper portion of the car, and when its distribution is required the steel gate is drawn, the current is thrown on, and the car delivers its macadam evenly on the track to be surfaced.

Under the franchise granted the company is compelled to handle freight at 15 cents per ton each way, and to

accord any mill owning its own car current and right-of-way over the tracks to any depot reached, at a charge for the service of a sum not exceeding \$2.50 per car per day. With one car such as that in use the wheat in and the flour out of a 1,000-barrel mill can be handled in fifteen round trips, or in one day's work. The route selected is on a street, the property on which is suitable for wholesaling purposes, and already some of the property owners are agitating the question of putting spur tracks into their property, so that freight can not only be handled in but handled out in less than carload lots, thus doing away with the cost of drayage between the wholesale establishments and the depots.

The last two months of operation has demonstrated that even with the convenience now perfected, the mill product can be handled at a less charge per steam freight



ELECTRIC FREIGHT SERVICE IN MAINE.

car than the switching charges prevailing in the city, viz., \$2.50 per car, and while it involves extra handling, the cost of this handling is exceedingly small. The development of the plan started in Spokane will no doubt be watched with a good deal of interest by the electrical fraternity, and the use of the car tracks in the city for freight purposes may prove to be a considerable source of revenue to the companies, to say nothing of the revolutionizing changes it suggests in city freight hauling methods. W. S. Norman, manager of the company, has handled the matter in a very creditable manner, and we feel sure that if others would show the same ability that Mr. Norman has shown in this direction, freight hauling would soon be a common thing in many other cities.

#### ANOTHER MAINE FREIGHT LINE.

In our issue of January last we described the Mousam River Railroad, which was one of the first to enter the freight hauling business with a locomotive. We now have the pleasure of showing the freight locomotive used by the Rockland, Thomaston & Camden Street Railway for a similar service. In this case it is a combination box car and locomotive. Each of the four axles is provided with a 25-horse-power W. P. motor. There is an additional freight equipment of two flat and one box car, used as trailers. The track connects with the Maine Central Railroad at Rockland, so that cars can be run into the freight depot of the latter road. From this depot all the through freight is taken. The local freight, which is the

greater part of the business at present, is delivered to the car. At Camden, the northern terminus, eight miles north of Rockland, the street railway has a freight depot at which goods are left under the same conditions as on steam roads.

The rates are \$1.50 a ton, except in the case of large shippers, who get a rate of \$1.25. Freight is billed to all points on the Maine Central and connecting railroads. It is usual to transfer all freight from the steam to the street railway cars at Rockland, but in several cases standard freight cars heavily loaded with machinery have been hauled the eight miles to Camden. There are some very sharp curves and steep grades (in one place  $8\frac{1}{2}$  per cent on a curve) but as yet everything has been hauled that the attempt was made to handle.

#### FRANKFORT, KY.,

is the scene of other profitable operations in the way of street railway freight. The Capital Railway Company, with its  $5\frac{1}{2}$  miles of electric line, of which Pat McDonald is president, and John T. Buckley, secretary and general manager, has inaugurated a transfer service

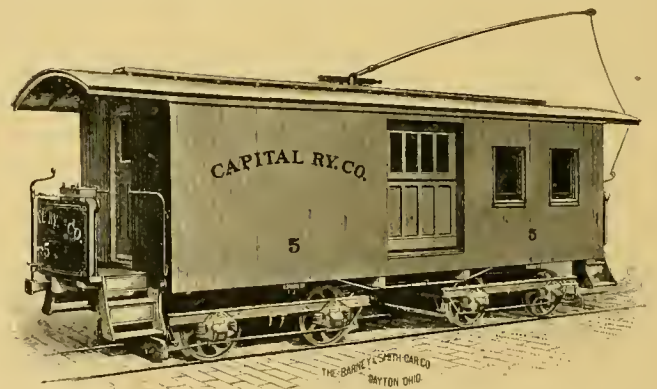

CAPITAL CITY FREIGHT CAR.

by which it carries freight in car load or broken lots over its road from the trunk roads entering the city, to manufacturing establishments. The motive power for this work is furnished by a combination freight and passenger motor car. This car, with its trucks, was built by the Barney & Smith Manufacturing Company, of Dayton, O. Its length over all is 28 feet. The wheel base of the two trucks is 5 feet. There is a 25-horse-power General Electric motor on each axle, and these motors are controlled by a special series-parallel controller. They are thrown with gradual changes from four in series to four in parallel. There is thus a very great range in speed and draw bar pull. By putting all four in series an enormous load can be pulled at a slow speed with economy. It will pull from one to three loaded freight cars up a six per cent grade and around sharp curves.

No small part of the freight business comes from the world renowned distilleries of this region, to which switch lines run. They, of course, use a large amount of freight. Strange to say, the road has to have a power plant. It would be thought that with so much 40-rd lightning on tap, this would not be necessary. However,

as the power station seemed to be one of the orthodox things to have in connection with an electric road, one was installed, with a 175-horse-power Dick & Church engine and two 80-horse-power Jenney dynamos. The scattered nature of the town and factories helps to make

has been found a very useful car during severe winter weather in breaking roads. By placing it behind a snow plow it will go through nearly every drift ever encountered. Besides using the locomotive for handling freight and snow, it is used in the busy summer season to haul two open trail cars afternoon and evening. "In fact," says M. H. Mero, "we have no more useful car on the road than our locomotive."

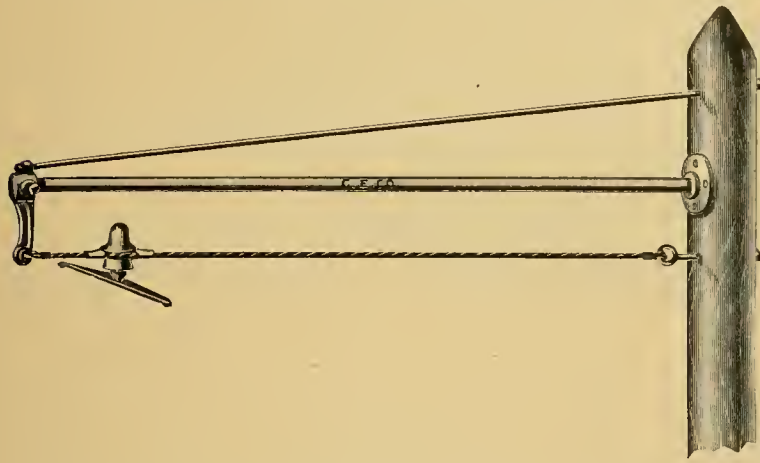

CREAGHEAD BRACKET.

The freight business has been running something over a year, but has only recently been put in good working order. Owing to the cut-throat competition of teams, there has been very little money in the venture so far, but the teamsters are beginning to realize that they can not keep up such competition much longer and are going out of the business.

Mr. Mero says: "Everything considered, we are well pleased with the freight business and have no doubt but that the ensuing year will show a success financially for it."

the passenger and freight business in conjunction very profitable. The freight trains are run between the regular passenger cars.

The overhead work is notable as being that designed recently by the Creaghead Engineering Company. In the suburbs, bracket construction is the order. The Creaghead Company has not only reduced the cost of bracket work with the accompanying design, but has reduced the cost of maintenance due to insulators on rigid supports.

Fifty-six pound T rails are spiked to 6 by 8 inch white oak ties two feet between centers. The country is very hilly, necessitating many cuts and fills.

The electric equipment throughout was superintended by The Creaghead Engineering Company. Superintendent John T. Beckley will gladly answer all communications from those engaged in similar projects.

THE HACKMENS' COMBINE DOWNED.

Judge Dallas, of the United States Circuit court, at Philadelphia, has handed down a decision denying the petition of the United States Government for an injunction restraining the Gettysburg Electric Railway from building its line across the battlefield. The operation of the road will now proceed. The only sorrowful ones are the hackmen, who have been reaping a golden harvest for twenty-five years from the visitors to the field. The route of this now famous line was illustrated by the REVIEW last year.

A MERRY T rail war has been waged at West Chester, Pa., with the victory for the T people.



ELECTRIC FREIGHT TRAIN—CAPITAL CITY RAILWAY.

At present only one round trip is made per day. The labor is performed by a conductor, who is the freight agent, and a motorman, who helps handle freight. In addition to the freight earnings of this locomotive it

It is rumored that the occasional complaints that the trolley cars in Brooklyn run too fast are instigated by the elevated competitors who greatly suffer in consequence.

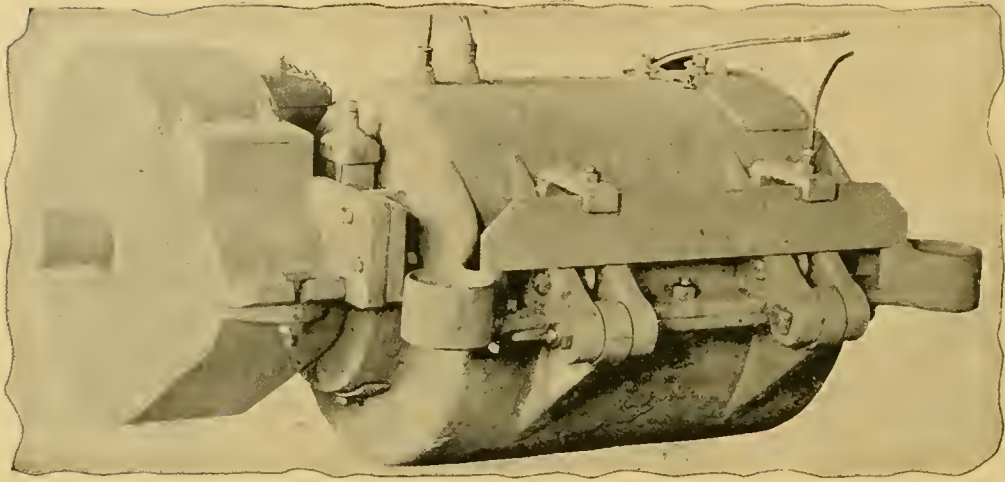

THE CARD STREET RAILWAY MOTOR.

It is our pleasure this month to welcome another company to the field of street railway motor manufacture. The recruit is the Card Electric Company, of Mansfield, O. The motor now offered by this company is a very compact and rigid arrangement of steel castings, and is entirely enclosed as are all modern motors. As will be seen from the engravings the motor is opened by swinging down the lower half. The hinge is on the end of the motor away from the car axle. Liberal contact is provided for the joints in the magnetic circuit at the point where the upper and lower halves of the motor frame come apart. The frame itself is very rigid. In the rear view is shown the steel bar for strengthening the cast extensions which form the spring supports. It equalizes the strain so that it does not all come at the corners. To lower the bottom half which holds the armature bearings a small chain block is fastened to a beam of the car body and to the extension made for the purpose on the lower half of the motor case. The armature and lower field can then be swung down by one man. The bearings on the car axle are not interfered with in this operation. The armature is the slotted drum type. The commutator is so constructed that by standing the armature com-

mutator end up, any segment can be renewed without interfering with the others. Thus a commutator with a soft segment may be saved to a long and useful life. It often happens that the life of a commutator is very short, simply because there is a soft segment and frequent turning down is necessary. When the armature is on end in the manner stated the segments are held in place by the angle at which the segments fit in the recesses. Special provision is made against oil creeping along the shaft and getting into the commutator and armature. This is done by placing a rubber ring between the hubs of the end plates.

The controller is neat and strong and of a rather novel design. Instead of having a number of sliding contacts the contacts are made and broken by eight automatic quick break switches actuated by an equal number of cams on the shaft of the controller. Every contact is thus broken in a quick and positive manner, and there can be no continued arcing. All the switches and cams are exactly alike, and there is only one size of wood screw and one size of machine screw in the whole controller.

Another feature of the equipment that will be appre-



REAR VIEW OF MOTOR.



ciated is the provision made for turning down the commutator without taking the armature out of its bearings. Not only is it a great saving of labor to be able to do this, but it does away with the danger that the shaft centers will be thrown out by careless workmen when putting the armature in the lathe. When the latter happens the commutator will run eccentric to the shaft. With the armature in its bearings this can not happen. To turn down commutators two simple attachments are bolted to the open frame of the motor. One of these is the tool holder. The other is a crank and pulley, over which a leather belt is run to the pinion. This is a very simple outfit as compared to a sixteen inch swing lathe with the necessary provisions for driving.

The Card Electric Company advocates the use of single motor cars for the majority of street railways now



OUTFIT FOR TURNING DOWN COMMUTATOR.

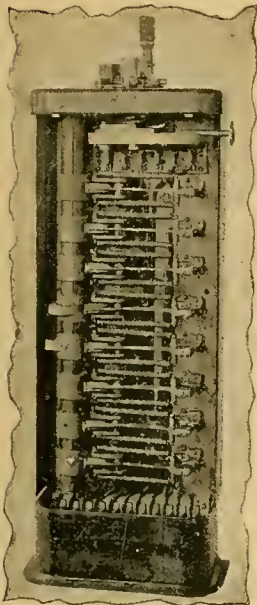

CONTROLLER.

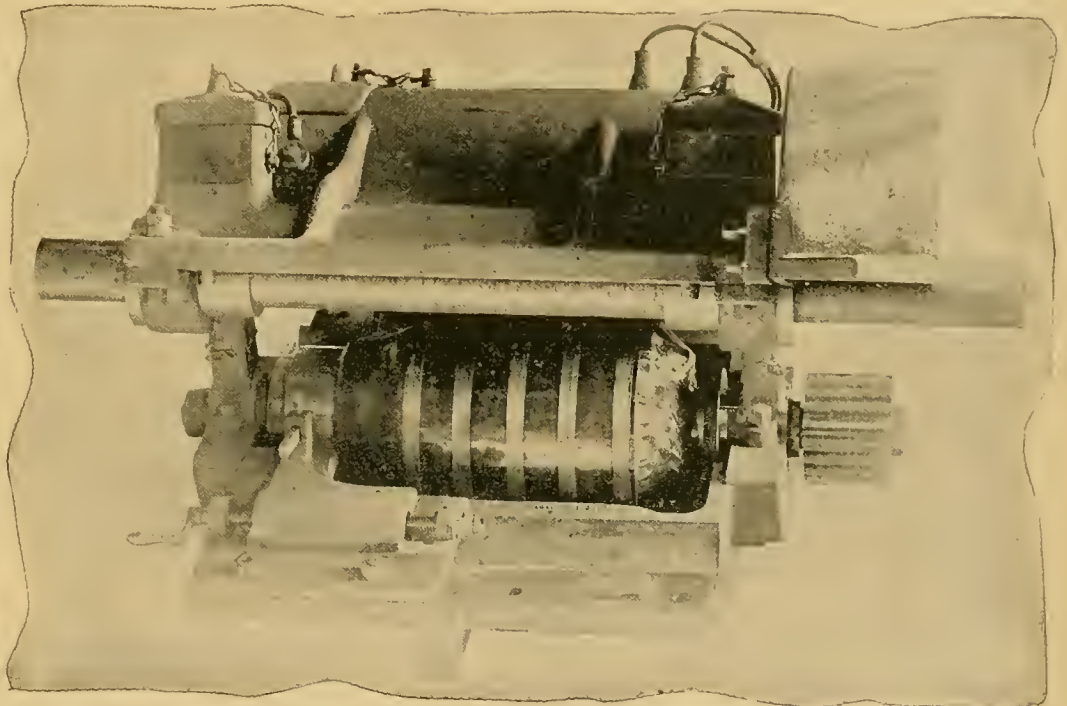

CARD MOTOR—OPEN.

operating, and has built its motors with this end in view. For very heavy service it does not deny the advisability of two motors on a car, but it claims that there are few places where a properly designed single motor would not do better; the first cost and expense of maintenance being so much less for the single motor. In proof of its proposition it offers the experience of the road at Mansfield, where "a double motor equipment was never on the line and is not needed." It is a hilly road with grades as high as  $7\frac{1}{2}$  per cent.

J. Holt Gates, the well known and successful sales agent, whose offices are in the Monadnock building, Chicago, will represent the Card interest in this city, and will bring to his new work a large and valuable acquaintance, among the street railway fraternity.

THE "no spitting" signs in Brooklyn cars are backed by the conductors. One was recently asked how he did it. "O," he replied, "when I see anybody about to spit I grab him by the throat, stop the car, and send for a cuspidor!"

A STREET car jaunt was recently taken by Winfield S. Nevins, of the Boston Herald, who started one morning from Oldtown, on a sixty mile ride on electric cars, which brought him back to Salem the same day in the evening. From Oldtown he went through Newburyport, Amesbury and Haverhill to Lawrence, thence skipping the ten miles between Lawrence and Wakefield, from the latter town to Boston, and then from Boston to Lynn, Salem and Wenham.

## OPERATING EXPENSE OF THE INTRAMURAL ELECTRIC ELEVATED RAILWAY.

The question of applying electricity in the operation of elevated railways is perhaps the one problem most prominent before the minds of engineers at present, since the decision of the Metropolitan of Chicago to use transmitted power.

The REVIEW for May contained a complete statement of the operating expenses of the Liverpool elevated, and the present number, by the kindness of General Manager W. E. Baker, is able to set forth in detail the results of the six months' operation of the Intramural railway at the time of its commission and use, and the public has since evinced a lively interest in its commercial history.

The line has been previously described in this magazine in detail, both as to its construction, its power plant and its cars, so that a brief resume is all that is necessary to bring to mind the premises of the present argu-

nothing of elevated cars, and yet, with these odds, not a single accident occurred in the handling of 5,803,895 passengers.

To each motor car were attached four G. E. 2,000 motors weighing 3,800 pounds each, including gears. Weight of motor car total, 44,600 pounds; weight of trail car, 27,000 pounds; one motor and three trailers to each train, making total weight of train of 62½ tons. Horse-power of each motor, 133. The highest speed run was 32 miles an hour; average speed, 10 miles.

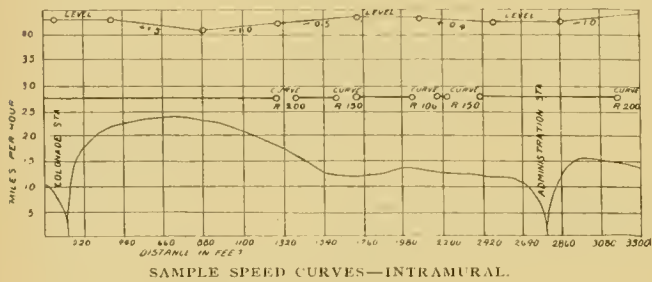
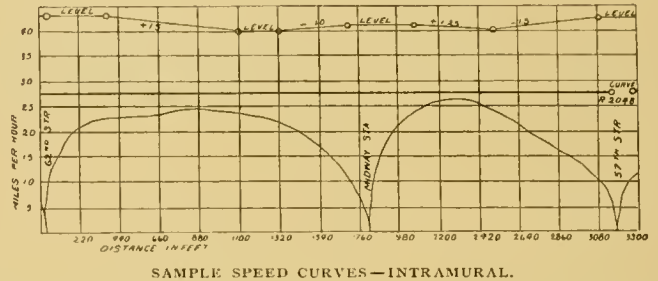

ment. The Intramural consisted of a wooden elevated structure of a sufficiently strong character, but temporary enough to be wrecked at the end of the period without too great waste. The columns were of wood, carrying wooden stringers and girders, surmounted by double tracks and four extra "third" rails for the current. The total length was three and a quarter miles of double track, looping at either end. The power house was a temporary structure also, but, although laboring under this difficulty, was well founded and amply sufficient for far greater output than was found necessary at any time during the exposition, with the exception of one occasion. Twelve trains during September and October was the maximum number of trains in use, with less numbers during the first of the exposition period. The month of May with its disappointingly small crowds has considerably affected the expense account in the total, and in strict justice to the management should be eliminated in a judgment of success or non-success of the project. The fact, too, that absolutely no data or precedent was available, made another difficulty which can be appreciated only by those who have gone through a similar experience. The road, of necessity, abounded in curves, varying from 200 feet to 90 feet in radius and 22 in number. Stations were 1590 feet apart, and the most of the passengers were totally unused to any trains, to say

Actual operation required 42-horse-power per train or a total of 500 horse-power for twelve trains. On Chicago day 125,476 passengers were handled on fourteen trains, with a mileage of 1,000 or 125 passengers per train mile.

During August, accidents from all causes necessitating stoppage of system made a total of 28 minutes in all; 20 minutes of this was from steam troubles.

The total earnings, expenses and net per train mile of the system for the term may be seen in the following table. May is eliminated, as the Fair had hardly opened and the system just being tested:

	PER TRAIN MILE.		
	Earnings.	Expenses.	Net.
June	\$2.82	\$0.81	\$2.01
July	2.44	.70	1.74
August	3.08	.63	2.45
September	4.40	.67	3.73
October	5.12	.71	4.41

The cost per passenger for the whole term, including the month of May, was \$0.021

The average current per train is indicated in the accompanying table of tests.

	K. W. HOURS.	NO. TRAINS.	AVERAGE K. W. HOURS.
August 2, . . .	1,752 min.	12	24.4
August 30, . . .	2,690 max.	12	32.0
Average (totals) .	671.4		
September 2, . . .	2,528 min.	12	30.3
September 18, . .	3,396 max.	12	40.4
Average (totals) . .	744.4		

The average for August and September gives 31.4 k. w. per train = 42.0 horse-power.

For the month of August the following is an exhibit of cost of the various departments of service:

## EXPENSES FOR AUGUST.

### POWER HOUSE.

Fuel \$1,379.17 (oil burned); labor \$1,348.18 (30 per cent of which was Exposition labor, which, strictly speaking, should not be counted); lubricants and waste, \$134.14; train miles run, 32,058; ton miles (empty trains), 2,042,094; passengers carried, 1,000,672; operation of power house per ton mile; fuel, 0.00067 cents; other expenses, 0.00072 cents; total, 0.00139 cents; total kilowatt hours developed in August, measured by Watt meter, 133,049.

### OPERATING EXPENSES.

	TOTAL.	PER TRAIN MILE.
General expenses, . . .	\$ 4,763.89	\$0.1486
Transportation expense, . . .	12,716.78	0.3966
Maintenance way and bldgs	1,209.38	0.0377
Maintenance equipment, . . .	1,393.15	0.0434
Total, . . . . .	\$20,083.20	\$0.6263

The cost of operating per train mile then was \$0.626 and the cost of fuel \$0.043.

The exhibit in the accompanying table is self-explanatory. It gives the expenses both of operating and for motive power for each month of the term.

The men employed on the pay-roll during the term for operating the system were as follows: Train service, 110; power house, 51; repair shops, 132; station service, 151; general offices, 23. This number was, of course, large in a few departments, resulting from a new system, but the handling of 5,000,000 in six months, with a train service of 110 men, deserves attention.

The repair shops employed 133 men because a large part of this work was really construction. Men competent to do the work were difficult to obtain, and more numerous changes were made in this department than any other. On August 15th the total number employed, including time keepers, inspectors, etc., was 25.

The total repairs for the period were \$5,916.35, of which electrical equipment counted \$4,047.28; electric power plant, \$38.91.

### TWO COMPARISONS.

The lessons to be drawn from the above statements are many, and we refrain from further detail except as regards comparison with steam elevated roads. The Manhattan Elevated, of New York city is chosen, and the cost per train mile shown. It must be borne in mind, however, that the Manhattan is a long established line. Its expenses have been worked down to a minimum with

## GENERAL EXPENSES.

	MAY.	JUNE.	JULY.	AUGUST.	SEPT'BER.	OCTOBER.	AVERAGE.
Pay rolls.....	\$ 7,150.95	\$14,673.52	\$19,259.00	\$19,904.80	\$14,466.71	\$14,774.26	\$14,204.87
Cost, per train mile, all items.....	1.69	.81	.70	.63	.67	.71	.87
Oil, per train mile, (gallons).....	8.99	2.88	3.44	2.19	3.56	4.36	4.28
Cost of fuel, per train mile, (cents).....	15.54	4.97	5.95	4.30	6.15	7.54	7.408
Operation of power house, per train mile, (cents)	15.46	5.61	6.15	4.21	4.08	4.20	6.618
Wages motormen, per train mile, (cents).....	8.42	6.74	6.38	6.09	6.09	6.53	6.708
Oil, per passenger.....	.38	.10	.14	.08	.08	.08	.172
Passengers, per train mile.....	23.75	28.31	24.46	30.97	44.29	51.32	33.85

## MOTIVE POWER EXPENSE—(CENTS.)

	Repairs, Equipment.	Fuel.	Lubrication Car.	Power house Wages.	Motormen's Wages.	Lubrication, Power house.	Repairs.	Total.	No. Motors.
JUNE.....	3.26	4.97	0.47	5.61	6.74	0.28	.06	21.39	8
JULY.....	3.13	5.95	0.32	6.15	6.38	0.79	0.29	23.01	12
AUGUST.....	3.04	4.30	0.40	4.21	6.09	0.38	0.42	18.84	12
SEPTEMBER.....	5.09	6.15	0.23	4.08	6.09	0.77	0.28	22.70	13
OCTOBER.....	6.12	7.54	0.42	4.20	6.53	0.70	0.57	26.08	11

The second comparison shows that:

In 1887 the Manhattan carried 158,963,232 passengers, at a cost of \$4,498,462 <sup>79</sup> / <sub>100</sub> or \$.028 per passenger.
In 1889 " " " 179,497,433 " " " 4,858,703 <sup>89</sup> / <sub>100</sub> or .027 " "
In 1890 " " " 185,833,632 " " " 4,854,202 <sup>86</sup> / <sub>100</sub> or .026 " "
In 1891 " " " 196,714,199 " " " 4,975,141 <sup>07</sup> / <sub>100</sub> or .025 " "
In 1893 " Intramural " 5,803,895 " " " 121,848 <sup>02</sup> / <sub>100</sub> or .021 " "

If the rate per passenger on the Manhattan, in 1891, had been 2.1 cents instead of 2.5 cents, the saving resulting, would have been, \$786,856<sup>80</sup>/<sub>100</sub>, to the Manhattan system.

the precedent of many years to draw lessons from. With the Intramural, the conditions were exactly antipodal. A new system, no precedent, temporary construction, vicious curves, short stops, and an immense num-

ber of passengers. The first comparison is of the cost per train mile on the Manhattan and the Intramural.

	Manhattan.	Intramural.
General expenses .....	6	16
Transportation expenses .....	44	44
Maintenance ways .....	6	3
Maintenance equipment .....	8	7
Total.....	64	70

The Overhead Electric Railway at Liverpool, England, shows an operating cost of 8.030 cents per train mile.

The value of comparisons of the three systems of elevated railways now most in evidence may not be of very great moment, as the conditions of each system are so radically at variance. The Intramural had, without doubt, the most to contend against, both as to practice and surroundings—a short time for proving its efficiency and a most trying roadway as to curves. The Liverpool Elevated, on the other hand, has a good straight route, plenty of time for construction, the very lowest priced labor, and cheap fuel convenient to the power house. The Manhattan Elevated has had years of trial in which to prune off too luxurious expense accounts, and a tried and tested system of locomotion, worked down to the last analysis of mechanical ingenuity and economical practice.

The basis upon which to compare, without giving tedious explanation, may therefore be stated as follows: 1, Generating station wages; 2, drivers' wages; 3, oil and waste; 4, repairs; 5, coal or fuel. Supervision is matter entirely governed by local necessity, magnitude of the undertaking and like environment.

The statement of the three systems is tabulated thus:

Item.	Liverpool	
	Manhattan.	Overhead. Intramural.
Power house wages		1.224 4.85
Drivers' wages	8.93	2.118 6.36
Coal or fuel oil	8.92	1.690 5.78
Oil and waste	.25	.272 .95
Repairs	2.41	.178 4.13

This statement is, of course, "cents per train mile," and totals are withheld in justice to each of the systems as it is not right to compare the totals where the components are, in a great measure, results of local conditions.

#### THE CRADOCK ROPE RECORD.

Our readers will remember the engraving in our January issue, of a section of rope made by Geo. Cradock & Co., of Wakefield, England, which had run 98 days in the tunnel loop of the North Chicago Street Railroad. In the April issue of a certain street railway publication, an individual signing himself an "American Manufacturer," disgraces both himself and the publication by a very mean and insinuating letter, in which it is intimated that the section of rope in question was not representative of the condition of the whole or was possibly a piece of new cable prepared on an emery wheel. He says: "The beautiful illustration makes one feel real sorry for the cable railway which threw away so perfect a cable pre-

maturely. It may be, however, that portions of the cable were in a very bad condition; would it not have been better to have shown samples of worn cable, as it is easy to find plenty of good samples carefully prepared on an emery wheel."

It is perhaps a sufficient answer to this to state the fact that the 98-day rope was not "thrown away," but has since run over twenty-eight days on Clark street, and is still running at this writing. It was certainly not strange that the rope was taken out of the tunnel loop long before it was worn out, as the loop is the key to the whole North Side system, and a stop on the loop means a blockade for the whole system. On any of the other lines a breakdown affects only the line on which it happens. Further on he refers to the 98-day run as a chance record, and one upon which no weight can be put as showing the quality of the cable. Such records are not made every day of course, but if the "American Manufacturer" had read through any of the articles which were published on the subject he would have seen the records of all the previous Cradock ropes used on the loop. We do not pose as an advocate of any English or American manufacturer although our sympathies are naturally on this side of the Atlantic, but we believe in calling a spade a spade, and if an English manufacturer turns out a rope that makes a remarkably good record in a certain place he ought to get the credit for it. We can say for ourselves and we think also for other technical papers that if an American cable should make either a good average or a high individual record in any place, it would be published with pleasure. There may be places where the Cradock rope would not show such good service, but the fact remains that it has made the highest average record in the North Side loop, and has very badly broken the record for length of life of an individual rope. A few days ago another one of these ropes was taken from the loop after an 88-day run. We have personally inspected the cable in its entire length, and it is in as good or better condition than the sample illustrated of the 98-day rope. It will also be put on another line, to be worn out. The shortest lived Cradock rope that has ever been taken out of the loop was one that was stranded by a gripman, at the age of seventy-eight days. The "American Manufacturer" says that "cables of the same manufacture, which lasted less than half the time of the good one in the same place, might have been mentioned in the article." Verily, they might have been mentioned, had we not been particular about telling the truth, but not otherwise.

INDIANLAND AND WONDERLAND is the title of a brochure published by the Northern Pacific Railroad, and sent to any address for six cents in stamps. It is different from the ordinary railroad publication, both in matter and artistically, and is well worth reading for the instruction and entertainment it contains, and should be in the hands of every tourist.

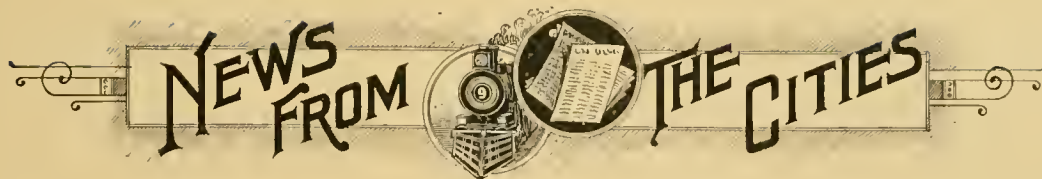

### Arkansas.

**PIKE BLUFFS, ARK.**—The Citizens Street Railway Company reorganizes. The officers now are: J. M. Taylor, president; John O'Connell, treasurer; Arthur Murray, secretary; H. P. Bradford, manager of the Cincinnati Incline Railway, general manager. The line will be changed to electric this summer.

**LITTLE ROCK, ARK.**—Case of the St. Louis Trust Company against the Capital City Street Railway Company has consolidated with the similar case of the Atlantic Trust Company vs. the same. These companies hold \$600,000 bonds of the Little Rock Electric Railway and ask foreclosure.

### Arizona.

**PHOENIX, ARIZ.**—The Electric Railway will extend a mile on Third avenue.

### California.

**SAN FRANCISCO, CAL.**—The San Francisco & San Mateo Electric Railway is granted an extension of time on its franchise.

**OAKLAND, CAL.**—T. C. Johnson, of San Francisco, is made receiver of the Vandercook line. Road will be kept in operation.

**SAN FRANCISCO, CAL.**—Secretary H. N. A. Foster, of the Presidio & Ferries Street Railway, applies for use of electricity on that line.

**LOS ANGELES, CAL.**—The Main Street & Agricultural Park Street Railway is reported favorably upon by the committee of the board of public works.

**SAN FRANCISCO, CAL.**—Adolph Sutro asks for a street railway franchise to Sutro Heights. He has the unqualified backing of all the property owners en route.

**LOS ANGELES, CAL.**—E. P. Clark, manager of the Consolidated, has returned from San Francisco and says the Pasadena road will be pushed to completion immediately.

**OAKLAND, CAL.**—G. Y. Loring resigns as superintendent of the Oakland Cable Railway and the Oakland Electric Railway Company. G. A. Loring, assistant, will also resign.

**OAKLAND, CAL.**—S. B. Lenagan, until recently superintendent of the Twelfth street electric road in Oakland, has been appointed superintendent of the San Francisco and San Mateo Railway.

**SAN FRANCISCO, CAL.**—The Market Street Cable Railway Company has begun the reconstruction of a number of its lines, putting in electricity. The road bed of a number of horse lines is being changed preparatory to electrifying.

**LOS ANGELES, CAL.**—Incorporated: Los Angeles, Pasadena & Altadena Railway, by G. G. Green, Pasadena's multi-millionaire; Senator Geo. H. Barker, of Philadelphia; Andrew McNally, of Chicago. Line will be completed in six months.

**SAN FRANCISCO, CAL.**—Sandford Bennett, secretary of the Dunham Carrigan & Hayden Company, has been appointed receiver of the San Francisco & San Mateo Electric Railway Company, at suit of the California Title Insurance Trust Company.

**SAN FRANCISCO, CAL.**—It is rumored that the Market street cable combine will consolidate with the Metropolitan Electric Railway and the San Francisco & San Mateo line. Several new franchises will be sought if the proposition carries through.

**PACIFIC GROVE, MONTEREY COUNTY, CAL.**—The stables of the Monterey & Pacific Grove Street Railway Company burned with six cars. An electric system will take its place next fall and in the meantime second-hand cars are wanted to resume service.

**OAKLAND, CAL.**—Twenty-third Avenue Electric Railway and the Oakland, San Leandro & Haywards file articles of consolidation. It will be known as the Oakland, San Leandro & Haywards Electric Railway, capital \$1,000,000. The five directors appointed for the first year are: Horry W. Meek and W. E. Meek of San Lorenzo, William J. Landers of San Leandro, Egbert B. Stone, of Elmhurst.

### Canada

**MONTREAL, CANADA.**—A strenuous fight will be made against the Montreal Island Belt Line Railway by residents of the proposed route.

**ST. JOHNS, N. B., CANADA.**—F. W. Warren is superintendent of construction on the improvements and extensions of the line. He is from Montreal.

**QUEBEC, CANADA.**—Le Compagnie de Tramways Electriques de Quebec is formed, to build elevated or surface tramways. Incorporators are: Messrs. J. B. Laliberte, J. U. Gregory, B. Leonard, P. B. Dumoulin, J. F. Guay, and F. M. W. Pampalon, all of this city.

### Chicago.

**CHICAGO.**—The city council grants rights to the North Chicago Electric Railway to trolley Armitage and Fullerton avenues.

**CHICAGO, ILL.**—The West & South Towns Street Railway dissolve injunction and will build between May and Johnson streets on 22nd street.

**CHICAGO.**—Incorporated: Chicago Suburban Electric Company, Chicago; capital stock, \$1,000,000. Incorporators—Ralph R. Bradley, Harriet M. Gibbs and Phillip S. Post, Jr. Bradley's address is 863 Rookery.

**CHICAGO.**—J. J. Burns, manager of the Cosmo Soap Company, 185-187 Wabash avenue, is manager of the Goshen-Elkhart Electric Railway, and wants prices on motor equipment, cars, trucks. Two miles of line ready.

**CHICAGO.**—Organized: The Arnold-McArthur Company, at \$100,000, to push the patents of Bion J. Arnold, by A. F. McArthur, B. J. Arnold and Henry W. Magee.

Ajax Feed Water Heater & Purifier Company, at \$3,000, by Wm. H. Smith, Leslie A. Gilmore and George Segume.

**CHICAGO.**—The city council has granted Mr. Yerkes right to trolley Lake street under the L. Right was also granted the North Chicago Street Railway to build a line on Southport avenue.

The Alley L, the Lake Street L and the Metropolitan are making an effort again to form a down town loop. The matter will be laid before the stockholders this week.

**CHICAGO.**—The West Side Construction Company, of New York, now building the Metropolitan Elevated Railway, Chicago, elects: R. Somers Hayes, Frederick P. Olcott, Samuel Thorne, Henry L. Higginson, Charles F. Dietrick, A. F. Wolcott and George C. Clark, trustees; Messrs. Thorne, Olcott and Dietrick being elected to fill vacancies. R. Somers Hayes was elected president of the company and George C. Clark, vice-president.

**CHICAGO.**—Lysander Johnson is the inventor of a suspended-car elevated electric system. He is president of the exploiting company; G. I. Ladd, secretary; L. Johnson, general manager, and J. M. Munn, assistant.

Incorporated: Co-Operative Electric Railway Company, Chicago; capital stock, \$1,000,000; operate electric railway, manufacture and deal in electric equipment, etc.; incorporators: Morris S. Evinger, Charles E. Burnap, and Isaac T. Dyer.

**Colorado.**

CRIPPLE CREEK, COL.—An electric railway is proposed to build from here to Victor. D. W. Diggs, of St. Louis, is behind the scheme.

**Connecticut.**

NEW BRITAIN, CONN.—F. G. Platt says that the electric railway will be running by September 1.

HARTFORD, CONN.—The Johns-Pratt Company, of this city, gets contract for overhead work of the Hartford Street Railway Company.

BRIDGEPORT, CONN.—Watts-Campbell Company of Newark, N. J., get contract for engines for Bridgeport Traction Company. Thos. Murray, of New York, will build track and overhead construction.

NEW HAVEN, CONN.—Clay, Moore & Co., of Philadelphia, have bought the Centerville Street Railway for \$225,000. It will be electrified.

NEW HAVEN, CONN.—The New Haven & Westerville Street Railway will build a line from the Grand avenue terminus to the village of Montwese.

HARTFORD, CONN.—The Hartford Street Railway Company buys the site and buildings of the Woodruff & Beach Company and will build a power station and repair shop.

BRIDGEPORT, CONN.—The construction of the Bridgeport Electric Railway began May 14. C. J. Field, of New York, is consulting engineer. Contracts let for power plant and rails.

HARTFORD, CONN.—Hartford Street Railway Company awards power house building to the Berlin Iron Bridge Company; poles to Morris & Tasker, Philadelphia; Roelblings' Sons get the wire contract.

BRIDGEPORT, CONN.—The Bridgeport Electric Railway contracts are as follows: Generators and motors, to the General Electric; rails divided between Johnson and Wharton; trucks to Brill; car bodies to Stephenson and Barney & Smith.

**Delaware.**

WILMINGTON, DEL.—Front & Union Street Railway Company elects: President, W. W. Pussey; vice-president, Preston Lea; secretary and treasurer, F. L. Kurtz; directors, George W. Bush, Edward Bringham, Jr., Dr. J. P. Pyle, Willard Salusbury, Alexander J. Hart.

**District of Columbia.**

WASHINGTON, D. C.—Washington, Alexandria & Mt. Vernon Electric Railway has gained entrance to the city.

WASHINGTON, D. C.—Dr. Wm. T. Barnard, past-president of the Alley L of Chicago, is dead, at the age of forty-five.

WASHINGTON, D. C.—Brott Electric Rapid Transit Bicycle Company elects directors at Alexandria, Va., as follows: E. S. Parker, John J. Hemphill, Bushrod Robinson, Joseph J. Reynolds, Virgil D. Stockbridge, Chas. A. McEuen, Charles M. Shelly, Peter P. Little and Geo. F. Brott.

**Florida.**

OCOLA, FLA.—H. H. Birdsey wants bids on complete telephone equipment.

INTERLACHEN, FLA.—A tramway line is to be built from the Francis packing house to the depot.

**Georgia.**

ATLANTA, GA.—The Atlanta Traction Company goes into the hands of W. C. Haile, as temporary receiver, on petition of bondholders.

ROME, GA.—American Security & Trust Company of Washington, D. C., will sell the Rome, Ga., Street Railway at trustee's sale. C. J. Bell is president of the Security & Trust Company.

COLUMBUS, GA.—The Columbus Railroad Company elects: J. F. Flournoy, president; Mr. C. B. Grimes, secretary and treasurer; Mr. J. H. Henderson, superintendent, and Mr. L. E. Garrard, attorney.

ATLANTA, GA.—The Atlanta Traction Company's affairs have been placed in the hands of two receivers, viz: E. B. Rosser and W. C. Hale. Mr. Hale will control the finances and Mr. Rosser the operation of the road.

**Illinois.**

SOUTH CHICAGO, ILL.—The street railway employes' strike is averted.

ELGIN, ILL.—The Dundee Rapid Transit Company has bought a site for its power house.

OREGON, ILL.—F. G. Jones has been made manager of the Rock River Electric Railway.

BELLEVILLE, ILL.—The Belleville Electric Railway Company has gained entrance into St. Louis, and will build connections at once.

ALTON, ILL.—The new line of electric to North Alton is to be built at once. Bonds have been sold by H. M. Noel & Co., St. Louis, and A. K. Root, of Alton, is president.

EVANSTON, ILL.—Business men meet to consider the extension of the electric road. Committee consists of W. S. Lord, chairman, and R. F. Milne, secretary, and others. Wilmette and Winnetka will co-operate.

SPRINGFIELD, ILL.—The following officers are reelected by the Street Railway Company for the ensuing year: President, T. J. Minary; vice-president, Blanford Wilson; treasurer, C. K. Minary; secretary, Philip Barton Warren.

**Indiana.**

MUNCIE, IND.—Capt. J. W. Hilligross is appointed manager of the Street Railway Company.

FORT WAYNE, IND.—C. L. Centlivre will double-track his street railway, extend and put in a new electrical equipment complete. It will cost \$60,000.

HAMMOND, IND.—The street railway offices have been removed to the East Chicago power house. A. M. Turner is made superintendent, vice Mr. Ward, resigned.

GOSHEN, IND.—C. E. Bickel, of Elkhart, and Judge Wanner, of this place, are busy getting the electric railway on its feet. Arrangements will be closed shortly.

TERRE HAUTE, IND.—The Terre Haute & Brazil Electric Railway is again securing right of way. Max Joseph and Robt. Smith, of Terre Haute, are behind the scheme.

GOSHEN, IND.—The Goshen Street Railway Company has filed articles signed by J. J. Burns, J. H. McIlhenny and K. G. Ripley, of Chicago; W. L. Stonex and E. A. Dausman, of Goshen. Capital stock, \$25,000, under the name of the Indiana Electric Railway Company, to connect Goshen, Elkhart and New Paris. The Cosmo Buttermilk Soap Company, of Chicago, is backing the enterprise.

**Iowa.**

CHEROKEE, IOWA.—W. H. Noyes, of Primghar, Iowa, will build an electric line here. He is backed by English capital.

OELWEIN, IA.—Judge Baylies of Chicago has secured a street railway franchise here and will begin work immediately.

KEOKUK, IA.—J. C. Hubinger says he will spend \$30,000 in improving the street railway system, buying new rolling stock, and improving car service.

SIoux CITY, IA.—By the breaking of a drum in the cable power house of the Sioux City Street Railway, the cable has been rendered useless, and electricity is now in use on the line. Loss by accident, \$20,000.

SIoux CITY, IA.—The Sioux City Traction Company has been formed to operate and succeed the Sioux City Street Railway in the forty miles of that system. The new company is composed of bondholders of the old. Of the stock, \$630,000 was paid for in bonds and the balance in cash. D. L. Wright, E. F. Stone and J. C. French, of Sioux City, and M. L. Kohler and J. W. Harner, of Philadelphia, are the directors and corporators.

## Kansas.

LEAVENWORTH, KAN.—The directors of the street railway company decide to build a line on the Northwestern right of way if franchise can be obtained.

WINFIELD, KAN.—Union Street Railway sold to T. J. Eaton of the Cowley County National bank for \$625. What will be done with it is not known.

LEAVENWORTH, KAN.—The Leavenworth Light & Heating Company will furnish power for the street railway and build additions to its power house to accommodate new machinery.

KANSAS CITY, KAN.—L. H. Hole, of Chicago, is elected vice-president of the West Side Street Railway. President W. N. Coler, Jr., of New York, has called a meeting within the next five weeks.

KANSAS CITY, KAN.—Incorporated: The Quindaro Park Electric Railway Company, at \$200,000, by C. C. Dall, Isaac P. Moore, W. J. Huffaker, J. C. Klamm, L. F. Bird, A. F. Smith and C. B. Forwood. It will be a summer resort line.

## Kentucky.

LOUISVILLE, KY.—Phil. Helfrich is made superintendent of the Highland Electric Railway Company. Improvements are now in order.

CATLETTSBURG, KY.—Differences between the Ashland & Catlettsburg Street Railway Company and the Chesapeake & Ohio are settled and the completion of the line is now assured.

## Louisiana.

NEW ORLEANS, LA.—The Jefferson Avenue Street Railway Company seeks incorporation. Officers are: William N. Louque, president; Octave Besanson, secretary and treasurer; William Cummings, superintendent; George A. Louque, Lestang St. Martin, Victor Pedelohore, Arthur J. Louque, Henry V. Deckbar and Thomas Walker.

## Maine.

BANGOR, ME.—Amos F. Gerald has sold his interests in the Waterville & Fairfield Railway to I. C. Libby, of Waterville.

CALAIS, ME.—Calais Street Railway Company elects: President, H. B. Goodenough, Boston; general manager, A. F. Gerald, Waterville; contractors for construction, Worcester Construction Company.

## Maryland.

BALTIMORE, MD.—President Oden Bowie, of the City Passenger Railway, is ill. Joseph H. Rieman acts in his stead.

BALTIMORE, MD.—The car fender committee of the city council elects Mayor Lathrobe, chairman, and Mendes Cohen, engineer.

BALTIMORE, MD.—Governor Frank Brown, of the state of Maryland, has been made president of the Baltimore Traction Company, vice T. Edward Hambleton, resigned.

BALTIMORE, MD.—The Canton, Sparrows Point and North Point Street Railway Company asks right of county commissioners to build an elevated railway, electric. T. Wallis Blackstone is attorney.

## Massachusetts.

BOSTON, MASS.—The house has passed the bill requiring street cars to be heated.

HULL, MASS.—Hull & Nantasket Street Railway Company will probably get its franchise.

CHELSEA, MASS.—Ordinance is introduced granting the West End Street Railway Company, Boston, rights for line in Chelsea.

NEWBURYPORT, MASS.—Frank Burnham, of Beverly, is made superintendent of the Newburyport & Plum Island Electric Railway.

ATHOL, MASS.—N. Sumner Myrick, of Boston, Mass., and Wm. B. Ferguson, of Malden, are chief holders in the Athol & Orange Street Railway Company, capitalized at \$60,000. L. B. Caswell will furnish specifications.

FALL RIVER, MASS.—Darmouth & Westport Railway has officers as follows: President, Frank W. Brightman, of Fall River; vice-president, Abbott P. Smith, of New Bedford; Robt. S. Goff, Fall River, secretary; Gilbert D. Kingman, New Bedford, electrical engineer.

ATTLEBORO, MASS.—Bondholders of the North Attleboro Steam & Electric Company are urged to join A. H. Haskel, of Pawtucket, R. I., in forming new company and rebuilding street railway plant burned last winter. Mr. Haskel is now owner of rights and property.

BOSTON, MASS.—The Meigs Elevated Railway is incorporated as the Boston Elevated Railway, by Joe V. Meigs, T. W. Hyde, Willard Howland, T. W. Myer, Joseph H. O'Neil, F. C. Patch, C. A. Whittier, Geo. H. Towle, William Spalding and Herman Hampt. The capital is \$10,000,000, with power to increase to \$20,000,000 and to issue \$20,000,000 in bonds.

HOLYOKE, MASS.—The People's Street Railway Company has organized by choosing these temporary officers: W. F. Whiting, president; R. F. Kelton, treasurer; Charles H. Curran, secretary; H. D. Bradburn and James E. Delaney, auditors; William F. Whiting, H. D. Bradburn, W. H. Brooks, C. H. Curran, R. F. Kelton, J. E. Delaney and C. O. Carpenter, directors.

## Michigan.

TRAVERSE CITY, MICH.—Traverse City Railroad Company elects Perry Hannah, president.

SAULT STE. MARIE.—The Edison Sault Electric Company has leased the Soo Electric Railway, and the service will be improved.

ALPENA, MICH.—W. P. Williams and W. A. Comstock, of Detroit, present 30-year franchise to city council for electric railway.

BATTLE CREEK, MICH.—Battle Creek Electric Railway sold to bondholders for \$110,000. Will be reopened for traffic in a few days. Minor supplies wanted.

GRAND RAPIDS, MICH.—G. Stewart Johnson, chief engineer of the Grand Rapids & Indiana Railroad, has been appointed general manager of the Grand Rapids Street Railway Company.

ANN ARBOR, MICH.—F. H. C. Reynolds and attorney, of Bangor, Me., is trying to rehabilitate the street railway. It is doubtful if it can be done. In this case the stockholders will be losers of \$60,000.

GRAND RAPIDS, MICH.—The North Park Street Railway Company is formally transferred to the Consolidated. A. J. Bowne and B. S. Hanchett, Jr., were elected president and secretary of the line.

CORUNNA, MICH.—S. F. Smith, trustee for bondholders, files bills to foreclose mortgage on the line. Odell Chapman, of Owosso, is attorney for the street railway, and Attorney Chandler, of Corunna, for Receiver Waters.

DETROIT, MICH.—Judge Donovan has granted perpetual injunction against the Detroit Suburban and the Detroit Citizens' street railways restraining the completion of the last half mile of proposed electric to the Six Mile road on Woodward avenue.

GRAND RAPIDS, MICH.—A new company is formed here, to make an appliance for preventing the burning out of motors. The officers are: President, D. Fred Sweet; vice-president, Sam'l Barnes; secretary, Chas. H. Annin; treasurer and general manager, Charles Kritzer. Mr. Barnes is superintendent of the electrical construction of the Street Railway Company. Mr. Annin is of the firm of J. C. Herkner & Co., and Mr. Kritzer is general manager for Butterworth & Lowe.

PORT HURON, MICH.—The long contemplated railroad from here to Lexington is organized as the Port Huron & Lexington Railway Company. The new company is capitalized at \$200,000, and the incorporators are Edgar H. Brennan and T. W. Bainbridge, of Toledo, O., and William C. Maybury, George Schaffer, William Nichols, C. W. Harrah and Elwood T. Hance, of Detroit. It is proposed to build an electric railroad between the points named.

## Minnesota.

DULUTH, MINN.—E. W. Wakelin has been made manager of the Park Point Street Railway Company.

MINNEAPOLIS, MINN.—Dow S. Smith, superintendent of the street railway in Minneapolis, has been transferred to the superintendency in St. Paul, to take the place of Frank S. Hoskins, resigned.

STILLWATER, MINN.—Stillwater Street Railway was sold May 6, to Judge Nethaway, attorney for Allen G. Curtis, trustee for bondholders, at \$69,254. Receiver will be discharged and road operated.

### Missouri.

ST. LOUIS, MO.—The Union Depot Railway has secured permit to build power house to cost \$5,000.

ST. LOUIS, MO.—The South St. Louis Electric Railway decides to extend to the C. B. & Q. depot from Sixth and Market streets.

ST. LOUIS, MO.—The St. Louis street railways are approaching the end of their coal supply, and looking about for a temporary oil burning system.

KANSAS CITY, MO.—Kansas City Cable Railway Company makes David Bontecou consulting engineer. He built the Grand avenue cable railway.

ST. LOUIS, MO.—Incorporated: Farmer Electric Company, of St. Louis; capital, \$60,000. Incorporators—John R. Farmer, O. M. Schmidt, W. B. Grable.

KANSAS CITY, MO.—Work will begin soon on the Westport & Waldo Park Street Railway, of which W. E. Winner is principal. Bonds to the amount of \$200,000 have been sold.

KANSAS CITY, MO.—The Elevated Railway has been secured by the Metropolitan system. C. W. Blair, Ft. Scott, Kansas, will be the new president, and Robert Gillam, Kansas City, will be general manager.

ST. LOUIS, MO.—The St. Louis and Kirkwood Railway Company has let contract for construction of its line to the Suburban Construction Company. The Construction Company will electrify and equip at \$150,000.

KANSAS CITY, MO.—The Metropolitan Street Railway Company has bought the South Suburban Street Railway from the General Electric Company and will build extension to it. Many minor improvements will be made.

ST. LOUIS, MO.—Arthur S. Partridge, Bank of Commerce building, St. Louis, is in the market for 1,000 tons of second-hand sixty-pound steel T-rail, guaranteed to be in first-class condition for relaying, with splices, f. o. b. cars Mt. Vernon, Ill., June and July delivery.

KANSAS CITY, MO.—Frank C. Peck, late of the Kansas City cable, is canvassing right of way for a new electric line to be backed by ex-President W. J. Smith. The East Fifth Street Railway is to be revived and converted into an electric. It was originally a dummy line, but will be electrified and extended.

### New Hampshire.

MANCHESTER, N. H.—City council grants franchise for an electric railway to Gen. Chas. Williams. Line must operate by June 1, 1895.

### New Jersey.

CAMDEN, N. J.—Residents in Gloucester county are trying to induce the Camden, Gloucester & Woodbury Electric Railway to extend to Clarksboro, Mullica Hill and other villages.

CAMDEN, N. J.—Camden, Gloucester & Woodbury Electric Railroad Company elects: President, J. Willard Morgan; secretary, Thomas P. Curley; treasurer, William J. Thompson; directors, J. Willard Morgan, Thomas P. Curley, William J. Thompson, Augustus A. Muller, Henry J. West, David Baird and Henry M. Harley.

### New York.

BROOKLYN, N. Y.—Another strike on the Atlantic Avenue is rumored.

LYONS, N. Y.—Consents are being obtained for an electric line by Charles R. Whitlock.

LIMA, O.—The Street Railway Company will build a new car barn 50 by 100 feet, one story high.

ROME, N. Y.—Rome City Railway Company elects: John S. Wardwell, president; Wm. P. Rayland, secretary and treasurer.

ROCHESTER, N. Y.—Joseph Hicks has been made superintendent of the Rochester Railway Company, succeeding William Roseborough.

NIAGARA FALLS, N. Y.—James Stewart & Co., of Buffalo, have contract for offices of the Cataract Construction Company, to cost \$40,000.

CANANDAIGUA, N. Y.—J. P. Brower, a Rochester engineer, is superintendent of construction of the electric railway. M. D. Munder is manager.

JOHNSTOWN, N. Y.—R. T. McKeever assumes general management of the F. J. & G. Electric railway, and T. C. Frenyear becomes superintendent.

BUFFALO, N. Y.—The Buffalo General Electric Company wants a 500-horse-power second hand, compound, high speed engine, delivered f. o. b. Buffalo.

ALBANY, N. Y.—The Consolidated Car Heating Company will extend its field and do not only a car heater business, but a general street railway supply business.

BUFFALO, N. Y.—James H. Small, of this city, is chief promoter of the Grand Island Electric Railway scheme. The capital stock of the company will be \$200,000.

NEW YORK CITY.—Organized: The Sterling Railway Supply Company at \$150,000, capital by Chas. M. Bolen, L. W. Pomeroy, Angus Sinclair and F. S. Gannon.

UTICA, N. Y.—The Street Railway Company has elected Byron B. Taggart, president; C. A. Starbuck, vice-president; Joseph Mullin, treasurer, and E. S. Goodale, secretary.

BUFFALO, N. Y.—The Buffalo, Tonawanda & Niagara Falls Electric Railway Company accepts the six months' extension of time for completion granted by the village board.

NEW YORK CITY.—A story is current that a powerful syndicate of Chicago and New York men will control the underground trolley patents of Granville T. Woods and push the same.

GLOVERSVILLE, N. Y.—W. L. Dougan, of Troy, is the surveyor of the line between Gloversville and Mountain Lake, five miles. Capitalists are: Elman Hiltz, A. J. Zimmer, and W. C. Miles, of Gloversville.

WHITE PLAINS, N. Y.—Committee of citizens on electric railway consists of Merwin Sniffin, chairman; S. H. Gainsborg, E. C. Sniffen, James B. Lockwood, S. L. H. Ward, Thomas Callan, Stanley F. Newell, Samuel J. Barnes, Wm. Horton and Wm. B. Sutherland, secretary.

NIAGARA FALLS, N. Y.—The Aerial Tramways scheme to cross the Falls seeks incorporation in Canada. The men connected are John Fleet and Joseph Tait, M. P. P., Toronto; L. C. Raymond, Welland; R. N. Campbell, Niagara Falls, N. Y., and G. W. Pound, of Lockport.

WATERTOWN, N. Y.—The Street Railway Company accepts the resignation of Geo. W. Adams as superintendent. Joseph Mullin and B. Taggart are elected to the executive committee. H. G. Manning takes temporary charge of the road, but Henry W. Hammond, of Carthage, will be made manager.

NIAGARA FALLS, N. Y.—Canadian capitalists are arranging to buy the Niagara Falls, Canada, and Drummondville Street Railway for \$40,000. The St. Catharines line will also be bought and extended. James Lowell, M. P. P.; H. Symmes, of Symmes & Dawson, St. Catharines; James Berry and McCrae, Robinson & Black are interested.

BINGHAMTON, N. Y.—The Court Street & East End Railway and the West Side Street Railway consolidate. The directors of the new company are: Jerome B. Landfield, G. Tracey Rogers, John Evans, Charles J. Knapp, Frederick E. Ross, George Whitney, Theo. S. Rogers and John P. E. Clark, of Binghamton, and Arthur A. Reeves, of New York City.



**CORTLAND, N. Y.**—Organized: The Cortland & Homer Traction Company, of Cortland. To construct an electric street surface railroad, twelve miles in length, from the depot of the Elmira, Cortland & Northern Railroad Company, in the village of Cortland, to the north corporate line of the village of Homer; and another line to begin in Cortland and terminate in the village of McGrawville, all in Cortland county. Capital, \$300,000, and directors, Herman Bergholtz, De F. Van Vleet and E. H. Bostwick, of Ithaca; P. S. Page, C. D. Simpson, Horace E. Hand and Isaac L. Post, of Scranton, Pa., and H. L. Bronson and E. A. Fish, of Cortland.

**NEW YORK CITY.**—Certificates of consolidation of the Metropolitan Street Railway Company, the Metropolitan Crosstown, and the Lexington Avenue & PAVONIA Ferry Company. It is to be known as the Metropolitan Street Railway Company, and the capital is \$13,500,000. There are nine directors as follows: Herbert B. Vreeland, Thomas F. Ryan, R. S. Hayes, Albert W. Fletcher, H. S. Beattie and Ralph L. Anderton, Jr., of New York; Daniel B. Hasbrouck and Charles E. Warren, of Brooklyn, and Henry A. Robinson, of Yonkers. The new road assumes all the debts of the others, amounting to \$9,250,000. The shares of the new company are to be given share for share for that of the companies combined. The capital stock is equal to the combined stock of the three.

## Ohio.

**CINCINNATI, O.**—Consolidated Company has about secured the Price Hill route.

**CLEVELAND, O.**—Street Railway Times Publishing Company is incorporated at \$3,000.

**AKRON, O.**—J. F. Seiberling has been given a franchise for the electric railway from Akron to Barbeton.

**TOLEDO, O.**—A 300-car car barn will be built by the Toledo Consolidated, of which W. S. Jewell is manager.

**SANDUSKY, O.**—Annual meeting of the Sandusky, Milan & Huron Electric Railway will be held here June 20.

**FREMONT, O.**—The Fremont Street Railway Company will build a one and a half mile extension this summer.

**COLUMBUS, O.**—North side citizens are trying to have an electric line built between Worthington and Westerville.

**LIMA, O.**—W. J. Ritchie asks for franchise for an electric line on the College street route. C. E. Lynch is city clerk.

**TOLEDO, O.**—The double tracking of certain lines and the changing of some cars is being pushed by the consolidated.

**CINCINNATI, O.**—The stockholders of the Cincinnati Street Railway Company authorize issuance of \$500,000 of new stock.

**EAST LIVERPOOL, O.**—Chances for the extension of the Electric Railway are bright. The company is willing and the citizens want it.

**CINCINNATI, O.**—A franchise is to be asked for the running of funeral cars on the Cincinnati Consolidated. Special cars will be required.

**MIDDLETOWN, O.**—Solicitors for right of way of the Dayton & Cincinnati Electric Railway are working in this district with great success.

**WARREN, O.**—The Trumbull Electric Railway Company is preparing to enlarge its plant and afford light and power facilities to town customers.

**MASSILLON, O.**—The Canton-Massillon Electric Railway will absorb the Massillon & Cleveland Railroad and electrify it. Lease is made for 99 years.

**TIFFIN, O.**—Joseph Murphy is made superintendent of the Tiffin Consolidated. Joseph Loudenslager is made treasurer, vice Dr. Rosendale, resigned.

**ASHLAND, O.**—Prominent citizens are trying to organize an electric railway company to build to New London, sixteen miles, to cost \$100,000.

**SANDUSKY, O.**—People's Electric Railway Company elects directors: W. H. Gilcher, Watson Hubbard, Geo. Barney, J. S. Cowdery, A. W. Prout, et al.

**DAYTON, O.**—The Dayton & Cincinnati Terminal Railway is incorporated by R. G. Ingersoll, W. R. Brown, Burton R. White and Samuel Hunt, at \$100,000.

**DAYTON, O.**—The Wayne Avenue Company elects: George W. Shaw, president; E. E. Bimm, vice-president, and Eugene Wuichet, secretary and treasurer.

**MARION, O.**—The long discussed Marion Electric Railway is organized thus: Edward Durfee, president and treasurer; Godfrey Leffler, vice-president; George Turner, secretary.

**DELAWARE, O.**—Knox County commissioners have granted the Delaware & Canterbury Electric Railway rights. The Delaware county commissioners will have franchise in hand now.

**HAMILTON, O.**—East End Improvement Company elects J. T. Middleton, president, and J. N. Lake, secretary-treasurer. Company will raise \$7,000 for completion of incline railway on Wentworth street.

**IRONTON, O.**—Heald & Holliday, of this place, have been granted franchise for ten miles of dummy or electric railway in Adams county, between Manchester and West Union. This line will be built as soon as a \$40,000 bond issue can be negotiated. No other railroad communication.

**COLUMBUS, O.**—Capt. Wm. Dinney and Geo. W. Fosier, of Worthington; John Knox, Albert Potter, of Westerville; and Hon. L. J. Critchfield, John G. Deshler and Chas. E. Burr, of Columbus, are organizing, to build a street railway line through Worthington and Westerville from Columbus.

**STEUBENVILLE, O.**—The Sprague Electric Railway and Motor Company brings suit against stockholders in the Steubenville Street Railway Company, asking for a receiver and alleging a mortgage of \$70,000 on the stock and equipment when the same is not worth \$15,000. New Yorkers are the principal stockholders.

**DAYTON, O.**—C. H. Smith, of Cincinnati, is bargaining for the Wayne Avenue Street Railway. The officers of the Dayton company are George W. Shaw, president; E. E. Bimm, vice-president, and Eugene Wuichet, secretary and treasurer. When the road is bought, \$200,000 will be expended in extension and improvement.

**AKRON, O.**—The Cleveland & Akron Electric Railway Company is organized by the following Cleveland and Akron men: C. F. Dunbar, Captain T. K. Dissette, C. B. Hineman, F. M. Chandler, Chas. G. Canfield, George Mathews, C. W. Wood, F. M. Clay and W. R. Coates. The line will touch villages en route and do a general express, freight and mail business.

**AKRON, O.**—Akron & Cuyahoga Falls Rapid Transit Company is formed to control the Cuyahoga water power and build a street railway line. Those interested are: R. J. Randolph, of Chicago, western manager of the Excelsior Electric Company; W. F. Hall, of the Niles Tool Works, Hamilton, O.; E. L. Babcock, of Cuyahoga Falls; E. F. Voris, of Akron, and Thomas F. Walsh, of Cuyahoga Falls.

## Oregon.

**ALBANY, ORE.**—Albany Street Railway has revived the project to extend to Sodaville and Waterloo.

**PORTLAND, ORE.**—Car shops of the City & Suburban destroyed by fire. Loss, \$3,000; insurance, \$6,000.

**PORTLAND, ORE.**—It is reported that San Francisco capitalists will buy the Portland First Street horse line and electrify same, building extensions. It is also reported that they will buy the cable road.

## Pennsylvania.

**SHARON, PA.**—Jas. O. Patterson, of the Shenango Valley Street Railway, has resigned. His successor is Frank D. Runser.

**PITTSBURG, PA.**—The Knoxville and the Fair Haven Land Companies have a plan to build a line of electric railway to Castle Shannon.

CARLISLE, PA.—The Carlisle Manufacturing Company have received the contract for putting up eight cars to be built for the trolley company.

EASTON, PA.—Young & Pearson, of this city, have begun survey for the East Bangor & Wind Gap Street Railway. The road is to begin operations in October.

NEW CASTLE, PA.—Contract for completion of the Brinton Park Street Railway has been let to Andrew Calucci, of Youngstown, O. Pittsburg men behind it.

WASHINGTON, PA.—A. E. Townsend, Pittsburg, purchaser of the Washington Electric Railway, will probably build a new power house and make extension of line.

BETHLEHEM, PA.—John G. Honecker, of Cleveland, O., has been appointed general manager of the Traction Company. He was formerly manager of the Warren, O., line.

JOHNSTOWN, PA.—The Johnson Company has bought out the Shepard Manufacturing Company, of Louisville, Ky., and will make the Louisville truck on an extensive scale.

LANCASTER, PA.—The Citizens' Electric Light, Heat & Power Company organizes at \$100,000 with J. L. Steinmetz, president; Chas. H. Locher, secretary, and Allan A. Herr, treasurer.

KNOXVILLE, PA.—Knoxville, Fair Haven & Mt. Lebanon Railway Company elects J. F. Grimes, of Knoxville, president; C. H. McKee, secretary, and decides upon definite plan for building the line.

PHILADELPHIA, PA.—Girard Avenue Passenger Railway Company is incorporated at \$9,000, by Henry C. Moore, David Golden, Hyland C. Murphy, Joseph C. Lugar, Thomas B. Foot and Nelson Saylor.

GETTYSBURG, PA.—The U. S. Circuit Court denies motion made for the United States to have the Gettysburg Electric Railway enjoined by preliminary injunction from building branch line to the battlefield.

PHILADELPHIA, PA.—The Philadelphia Traction Company is sued by John C. Henry, of Westfield, N. Y., for alleged infringement of patents. P. A. B. Widener says the matter is of no moment and does not signify much.

WIND GAP, PA.—State Belt Electric Railway, incorporated by A. O. Allen, of Portland, Pa.; T. Seems, Wm. Winsborough and G. W. Mackey, of Bangor, Pa., and Richard Jackson, and Wm. Turner, of Penn Argyl, Pa.

PHILADELPHIA, PA.—The Buttonwood & Fairmount Park Electric Street Railway Company has secured charter for five miles of street railway on the route indicated in the caption. Henry L. Everett, 227 South Sixth street, is president, and the capital is \$30,000.

PHILADELPHIA, PA.—Diamond Street Passenger Railway Company, an off shoot of the Peoples Company, elects officers. The capital of the company is \$6,000, and the incorporators include Henry C. Moore, David C. Golden, Hyland C. Murphy, McClellan Hersh, Joseph C. Lugar and Thomas K. Foot.

HONESDALE, PA.—Incorporated: The Honesdale Electric Street Railway Company, Honesdale, to run through the principal streets of Honesdale, a distance of one mile; capital, \$100,000. President, Lorenzo Grambs, Honesdale; directors, Eben H. Clark, W. N. Alberty, L. Grambs, M. M. Treadwell, W. H. Dimmick, Honesdale.

MAHONEY CITY, PA.—The Lakeside Electric Railway will extend to Shenandoah. The officers of the Lakeside Railway are: Hon. Dallas Sanders, president; John A. Johann, secretary, both of Philadelphia, and Hon. D. D. Phillips, treasurer, Gordon, Pa. The board of directors includes, in addition to the executive officers, A. P. Blakeslee, superintendent of the Lehigh Valley Railroad, Delano, Pa., and John Drake and Captain J. F. Bailey, of Philadelphia.

PHILADELPHIA, PA.—The Market Street, Richmond & Frankfort Street Railway Company is incorporated. The capital is \$180,000, and the officers, who are also corporators, are: President, Walter N. Boyer, Philadelphia, 1785 shares; directors, Radcliffe B. Mills, Philadelphia, ten shares; Milton M. Dorland, Philadelphia, 1785 shares; E. A. Graves, East Berlin, Conn., ten shares; W. W. Hirst, Philadelphia, ten shares. The proposed new road is to be operated by other than locomotive power.

PHILADELPHIA, PA.—The following street railway companies have been chartered: The Citizens' North End Street Railway Company, capital \$36,000. The line commences at Sedgely avenue and Germantown avenue, and runs on Eleventh, Chew, Tenth and Clearfield, with right to use Glenwood. The Citizens' Clearfield and Cambria Street Railway Company, capital \$6,000. The line commences at Tenth and Clearfield streets, and runs on Clearfield, Ninth, Cambria and Hutchinson streets. The Brown and Parrish Streets Railway Company, capital \$15,000. The line begins at Fifth and Brown, and runs on Brown, Third, Fifth, Inquirer and Parrish streets. The Citizens' East End Passenger Railway Company, capital \$15,000. The incorporators are the same for the four lines, viz: Jeremiah J. Sullivan, Robert C. Brewster, James F. Sullivan and George S. Gandey.

### Rhode Island.

WESTERLY, R. I.—The Westerly city council grants franchise for the Pawtucket Valley Street Railway.

### Tennessee.

NASHVILLE, TENN.—R. W. Hunter buys the Overland Electric Railway for \$10,000, subject to \$100,000 mortgage bond.

CHATTANOOGA, TENN.—The Chattanooga Electric Railway is about to make some extensive improvements. More cars will be put on.

NASHVILLE, TENN.—The United Electric Railway Company reorganized with W. H. Jackson, Nashville, president; T. M. Steger, Nashville, vice-president; R. F. Jackson, Nashville, secretary and treasurer.

### Texas.

MARSHALL, TEX.—A local company will buy Hynson Springs and build seven lines of electric railway to it.

FT. WORTH, TEX.—Robert McCart, of this city, has been made receiver for Arlington Heights Street Railway Company. The line will continue operation.

GALVESTON, TEX.—Col. W. H. Sinclair has sold \$1,000,000 in 5 per cent bonds to New York parties. The line will pay off outstanding bonds and floating debts.

DALLAS, TEX.—Henry C. Scott, of St. Louis, buys the Dallas & Ft. Worth Rapid Transit Railway for \$90,000, and the West Dallas Railway for \$19,000. He will improve.

### Utah.

SALT LAKE CITY, UTAH.—The owner of the Mercur properties will build a tramway in the Camp Floyd district.

SALT LAKE CITY, UTAH.—The Salt Lake Street Railway Company elects officers as follows: A. W. McCune, president; R. C. Chambers, vice-president; J. S. Wells, secretary and treasurer, and W. P. Read, superintendent. The directors elected are: R. C. Chambers, A. W. McCune, Francis Armstrong, Spencer Clawson and Walter P. Read.

### Washington.

SEATTLE, WASH.—F. W. Spear and Nathan Anderson report that the route of the proposed electric line to Edmonds is feasible.

TACOMA, WASH.—The employes of the Tacoma & Point Defiance Street Railway Company ask a receiver, claiming \$5,500 in wages.

### West Virginia.

WHEELING, W. VA.—Adam Mauer has been appointed power house engineer for the Street Railway Company.

WHEELING, W. VA.—The Benwood & Moundsville Street Railway is a sure go. Contracts to be let soon. Col. Ben Wilson, of Clarksburg, is at the head of the affair.

### Wisconsin.

OSHKOSH, WIS.—Real estate board announces that the Interurban between here and Kaukauna is assured. It will cost \$350,000.

PORT HURON, WIS.—Col. William Nichols, of New York, and E. H. Brennan ask \$20,000 bonus of Port Huron to begin construction of the electric road this summer.

## THE ACCIDENT BLANKS OF THE VICTORIA ELECTRIC RAILWAY & LIGHTING COMPANY.

The Victoria, B. C., Electric Railway, under the superintendency of F. W. McCrady, has a few features in the system of printed blanks in use that are worthy of special consideration. One of the neatest plans for keeping accident reports that has recently come to our notice is the little four page book used for this purpose by this company. Each conductor carries with him a number of these books, which are 8¾ by 3¾ inches, a size convenient for carrying in the pocket and for filing. Each book is intended to contain the conductor's complete report of one accident. They have tough tag board covers, and contain four pages for the conductor's entries. The conductor's reports are thus made in a neat, permanent form, and they can be properly filed away. The front cover contains the following blanks, which are filled out by the superintendent and accountant, who receive and put on record the report.

*Accident No.*.....  
*Injury to*.....  
*Of No.*.....*Street.*  
*At*.....  
*Car No.*.....  
*Conductor*.....  
*Motorneer*.....  
*Report received*.....*M.*.....*189.*..  
*Supt.*  
*Report filed*.....*M.*.....*189.*..  
*Accountant.*

On the inside of the front cover follow the company's rules in regard to accidents.

No. 8—ACCIDENTS. The conductors will use every possible precaution to avoid accidents. If an accident should occur they will

1st—Stop the car immediately, ascertain the name, residence and business address of the injured person, render all possible assistance, if necessary taking them to a drug store, if one is near, or summon a physician.

2nd—In case the accident is at all serious, conductor will telephone immediately to Superintendent's office—telephone 486—stating place and nature of accident.

3d—They will ascertain name, residence, and business address of all passengers in the car, and of all persons who witnessed the accident, and at end of trip make out a written report and send same at once to Superintendent, giving full and detailed report of the occurrence.

4th—Conductors will refrain from conversation or giving any information of any accident to any person other than the proper officers of the Company. You will not accompany injured party home or call upon same, without consent of Superintendent.

NOTE.—The above rules regarding accidents are of the utmost importance and must be observed, no matter how slight the accident to person or property.

For example: If a person falls in stepping from your car, even when your car is at a standstill and the accident is due entirely to passenger's own carelessness, and passenger insists that he or she is not hurt, the name and address of such person, with witnesses, must be taken and reported to the Superintendent. This is absolutely necessary for the protection of both Company and conductor. Accident reports must be handed to proper officer of the Company at the first opportunity.

AVOIDING ACCIDENTS.—Ring the gong when approaching intersecting streets, street corners, alleys, curves, etc. Make yourself familiar with rules on pages 11, 12 and 13.

When approaching bridges, viaducts, poles or other objects near to track, conductors will warn all persons standing on footboard of open cars, or on rear platforms of closed cars.

F. W. MCCRADY,  
Superintendent.

In the remaining four pages the conductor enters his report in the blanks left for the purpose. The lines run the long way of the book. The blank items are shown here on a slightly reduced scale and with some of the blank lines omitted.

(Page 1)

To.....*Supt.*.....*188.*..  
 Dear Sir: An accident occurred in connection with my car this day, the circumstances of which are as follows:  
*Car No.*.....*Conductor*.....*Motorneer*.....  
*Exact place*.....*Exact time*.....*hrs.* <sup>A. M.</sup><sub>P. M.</sub>.....*min.*  
*Car going*.....*Speed*.....

### INJURY TO PERSONS.

NAME.	RESIDENCE.	BUSINESS ADDRESS.	NATURE OF INJURY.
.....	.....	.....	.....
.....	.....	.....	.....

(Page 2)

### DAMAGE TO PROPERTY.

NAME OF OWNER.	RESIDENCE.	BUSINESS ADDRESS.	EXTENT OF DAMAGE.
.....	.....	.....	.....
.....	.....	.....	.....

### WITNESSES.

NAME.	RESIDENCE.	BUSINESS ADDRESS.	RESIDENT OR TRANSIENT.
.....	.....	.....	.....
.....	.....	.....	.....

(Pages 3 and 4.)

### HOW ACCIDENT OCCURRED.

.....  
 .....  
 .....  
*Motorneer.* *Conductor*

When an armature is taken out it must have a tag attached to it with the following items:

1. Armature No.....
2. Extent of damage.....
3. Date damaged.....
4. Cause of damage.....
5. From car No.....
6. Motorman.....
7. Repaired by.....
8. Time consumed.....hours.
9. Placed in car No.....
10. Date same was replaced.....

Remarks.....  
Foreman.

The first six lines are filled out by the foreman, the seventh and eighth by the armature winder. The last two are filled by the foreman when the armature has been put on a car, and the tag is then returned to the superintendent. A record is thus kept on all repair work. Report blanks are all on tough manilla board or paper, which fact has a great influence on the neatness with which they can be kept. The whole system of blanks is a credit to the management and will bear imitation.

GOOD, IF NOT TRUE.

“Good, if not true,” like the Spanish story, is the tale that comes from the North Shore Electric Railway, Chicago. It seems that on that electric line the insulation of one of the iron poles was broken and as the pole was set in cement it was nearly insulated. The consequence was that the iron was pretty well charged. About this time an elongated greyhound, belonging to an Evanston citizen, came along and with the well-known fondness of canines for all such objects, investigated the pole. The result is said to have been fatal. This, however, did not deter a fine fat poodle and a shaggy spaniel from meeting a similar fate, and by the time the line men arrived six dogs had yielded up their lives to the ravages of civilized life.

WEST END TRANSFERS.

The West End Street Railway of Boston, in response to inquiries from the Rapid Transit committee, showed the number of transfers issued during the year ending September 30, 1893. Free transfers issued numbered 11,716,557, of which 10,823,201 were collected; 4-cent and 4½-cent checks issued and collected were found to be 11,652,843. The free transfer system cost last year \$18,067 for wages, \$3,928 for printing and \$1,612 for rent of waiting rooms, a total of \$25,608.

On May 3 the lower section of the Broadway, New York, cable was put into commission. The rope is 5,000 feet long and runs to South Ferry. The officers of the road made the initial trip.

STREET RAILWAY PATENTS.

ISSUED MAY 8, 1894.

Contact device for electric railways. David F. Graham, Springfield, O., and William P. Allen, Chicago, Ill., assignors of one third to Oliver S. Kelly, Springfield, Ill.....	519,328
Switch for overhead trolley tracks. Charles G. Schmidt, Cincinnati, O.....	519,351
Conduit electric railway. James F. Cook, Mansfield, O.....	519,380
Life guard for street cars. James Campbell, Brooklyn, N. Y.....	519,402
Trolley wire hanger. Albert B. Crouse and Charles A. Rutlige, Passaic, N. J.....	519,446
Electro hydraulic car motor. Charles E. Emery, Brooklyn, N. Y.....	519,462
Fender for cars. Arthur H. Jelly, Cambridge, Mass.....	519,472
Trolley wire crossing. Edward H. Allen, Cramers Hill, N. J.....	519,519
Overhead cable traction. Walter G. Berg, New York, N. Y.....	519,561
Cable replacer. John Z. Murphy, Chicago, assignor one-half to Frank W. Hudson, same place.....	519,586
Electrical water wheel governor. Earl P. Wetmore, Helena, Mont.....	519,597
Trolley wire hanger. Charles F. Strasburg, Lincoln, Neb.....	519,621
Safety car fender. George C. Schmidt, Baltimore, Md., assignor of one-half to Abraham Harman, same place.....	519,648
Electrical propulsion of railway cars. Jean J. Heilmann, Belfort, France.....	519,674

STREET RAILWAY PATENTS, ISSUED MAY 15, 1894.

Switch for city railway, Joseph Shutt, East New York, N. Y.....	519,741
Substructure for railway rails. James M. Price, Philadelphia, Pa., assignor to the Price Railway Appliance Company, of Pennsylvania.....	519,772
Fender for street railway cars. John B. Bailey, Baltimore, Md.....	519,803
Trolley wheel. Van Dyke Crusier, Flatbush, N. Y.....	519,837
Contrivance for diminishing the danger to foot passengers from street railways. John Jernetz and Ferdinand Jeniczek, Vienna, Austria-Hungary.....	519,911

STREET RAILWAY PATENTS, ISSUED MAY 22, 1894.

Electric railway trolley. Thomas M. Brown, Cleveland, O.....	520,156
Trolley wire hanger. Thomas J. McTighe and Sumner W. Childs, New York, N. Y.....	520,213
Railway car fender. John W. T. Gilliam, Baltimore, Md.....	520,230
Safety attachment for street cars. Henry A. Howe, Albion, assignor to himself and Joseph Norwood, Brooklyn, N. Y.....	520,233
Safety car fender. Frank I. Clark, Baltimore, Md.....	520,255
Grip mechanism for cable railways. Charles I. Earll, New York, N. Y.....	520,259
Electric railway. Ernst W. Von Siemens, Berlin, Germany, assignor to Siemens & Halske, same place.....	520,274
Conduit electric railway. William R. De Voe, Shreveport, La.....	520,304
Block system for trolley railways. Willard F. Lewis, Swampscott, Mass.....	520,323
Electric traction apparatus. Paul Schoop, Zurich, Switzerland.....	520,340
Conduit electric railway. Guarantee Trust and Safe Deposit Company, administrator of Charles Wm. Siemens, deceased, Philadelphia, Pa.....	520,356
Transferring cable cars at intersecting points. John Kratz, Baltimore, Md., assignor one half to Joseph H. Pfister, same place.....	520,364
Car brake. Thomas H. Allen, Toronto, Can.....	520,384

ISSUED MAY 29.

Electric railway turntable. Rudolph M. Hunter, Philadelphia, Pa.....	520,527
Trolley wire support. Budd J. Jones, Sioux City, Ia.....	520,737
Conduit railway trolley. William Lawrence, New York, N. Y.....	520,758

MONTREAL conductors must be able to speak both English and French and must be 5 feet 5 inches tall at least.

Playing Cards.

You can obtain a pack of best quality playing cards by sending fifteen cents in postage to P. S. Eustis, Gen'l Pass. Agent, C. B. & Q. R. R., Chicago, Ill.



THE American Electrical Works, Providence, R. I., is very busy with line work.

THE Schuttler Manufacturing Company, Chicago, has gone into the hands of a receiver.

THE Ellis Car Company, Amesburg, Mass., still continues the manufacture of its well known snow plows.

THE Eastern Electric Cable Company, of Hamshire street, Boston, is meeting with a good sale of "Clark" wire.

THE Lane & Bodley Company, of Cincinnati, finds inquiries very numerous with excellent prospects for sales later on.

A. GROETZINGER & SONS, Allegheny, Pa., report orders plenty and customers well pleased with Dermaglutine pinions.

THE Pittsburg Steel Hollowware Company, of Pittsburg, Pa., finds business improving, with more enquiries and increased sales.

P. M. McLAREN, general agent of the Abendroth & Root Manufacturing Company, New York, spent a few May days in Chicago.

THE LaCledde Car Company, St. Louis, has captured a 50-car order from the Cincinnati, Covington & Newport Street Railway.

RIES & SCOTT, of Baltimore, have published a description of their alternating current motor, which they announced some time ago.

THE Clonbrock Steam Boiler Works have received many flattering testimonials of the working of their Morrin climax steam generator.

THE Sandusky, Milan & Norwalk Electric Railway of Ohio will put in a private telephone line for train dispatching and similar business.

THE Barney & Smith Car Company, of Dayton, O., will make 50 cars for the Cincinnati, Covington & Newport Street Railway Company.

THE Wallace Electric Company, Chicago, has been very busy of late filling orders for its promising material and the W. & W. lightning arrester.

WILLIAM H. WHILDEY has taken charge of the Schuylkill Electric Railway Company, of Pottsville, Pa., in place W. H. Conrad, the former superintendent.

ALBERT & J. M. ANDERSON, of Boston, are very busy getting out orders for their well-known overhead equipment. The works are running full time and full force.

THE Bates Machine Company, Joliet, Ill., is doing a first-rate business. The award of the judges of the World's Fair gives a first-class judgment on its Corliss engine.

THE first electric car across the Mississippi river at Davenport, ran over the Tri-City line May 4. This is the third line of street railway to cross the Father of Waters.

CHAS. A. SCHIEREN & Co., 47 Perry street, New York City, report an order from the Brooklyn City Railroad Company for an extra belt 91 feet long and 60 inches wide.

THE PITTSBURG BRIDGE COMPANY has an order for a 60-foot plate girder span to be erected on the Sharpsburg extension of the Allegheny Traction Company's electric railway.

THE Walker Manufacturing Company, by Kohler Brothers, western agents at Chicago, has sold ten equipments of its motors to the Green Bay, Wis., Street Railway Company.

THE Buckeye Engine Company, Salem, O., has established a St. Louis agency for its excellent engine in the Security building. The Southwest is a large user of Buckeye engines.

THE Brownell Car Company, St. Louis, is holding its own with the accelerator. Recent orders come from Chicago, where the accelerator was winner in a race with a lot of entries.

THE General Electric Company has closed the contract for the Poughkeepsie & Waffingers Falls Railway, of Poughkeepsie, N. Y., covering two 200 K. W. direct connected generators, 40 G. E. 800 motors and type K controllers.

F. W. WEBSTER & R. H. Beach, as Webster & Beach, 44 Broad street, New York, have gone into the supply business for street railways. Both are well known in the electrical field and will furnish all kinds of supplies except generators.

J. M. Denniston, the western salesman of the Davis Car Shade Company, of Portland, Oregon, has sold 380 of the Davis Shades to the Chicago General Street Railway Company. This means the equipment of twenty-five cars with the popular Davis Shade.

THE Sperry Electric Company has sold 20 equipments for the Price Hill lines of Cincinnati. The first installment of 125 motors for the People's Traction Company, Philadelphia, has been delivered, and 17 equipments for the Waterbury, Conn., line have been placed.

THE 88-day loop rope of the North Chicago Street Railroad Company, which was made by George Cradock & Co., of Wakefield, England, will be used on another line, still being in good condition. Ropes made by other firms for this loop lasted 31 and 39 days respectively.

J. HOLT GATES has been appointed western agent for the Card Electric Company's street railway motors, made at Mansfield, O. Mr. Gates still retains his relations with the Mather Company, and will prosecute the good work for both concerns with his usual ability and success.

THE McGuire Manufacturing Company, of Chicago, has purchased the controlling interest in the Columbian car heater, and will add it to its list of specialties. If the judgment of the company is as good in the stove matter as it has proved to be in its other specialties, it will soon be known throughout the land.

THE Burton Electric Heating Company has been organized as a subsidiary organization to the Electric Forging Company. It will operate the company's

senting a fund of valuable facts regarding water tube boilers in general, and the Improved Root Water Tube Boiler in particular. Write for their "Information Pamphlet No. 3."

WM. R. RONEY, inventor of the mechanical stoker and head of the mechanical draft department of Westinghouse, Church, Kerr & Company, was in the city on business recently. The mechanical draft of this company, which consists in placing a fan in the stack in connection with Green or other fuel economizers, is coming into extensive use and favorable reputation.

THE Sterling Supply & Manufacturing Company, New York City, is doing a good business. The Sterling register appears prominently, the following orders being an excerpt from the list of lines now using them: Atlanta Traction Company, White Line, Dayton, O., Poughkeepsie & Wappinger Falls, Citizens Street Railway, Indianapolis and many others. The sand box specialty is in use on the Consolidated Traction Company, Jersey City, N. J., the City & Suburban, Baltimore, and many others.



patents in New England. The new company is officered by Geo. D. Burton, president; F. J. Hutchinson, treasurer, and the factories will be at Woburn, Mass.

THE W. S. Hill Electric Company, of Boston, Mass., has shipped during the present month to one company, two orders for switches that weighed over eleven tons, and notwithstanding the hard times the gross sales for the past nine months average nearly 75 per cent more than for the corresponding months of a year ago.

THE Creaghead Engineering Company of Cincinnati is finding the demand for its flexible pole bracket much greater than was anticipated. This bracket has a wire stretched from its extremity to the pole on which to put the trolley hanger. This gives flexibility, while at the same time reducing the cost of bracket construction.

THE Abendroth & Root Manufacturing Company, 28 Cliff street, New York City, has issued for gratuitous distribution some finely illustrated trade literature, pre-

T. A. WIGHAM, of the Greiner Economical Cupola Company, 714 Bort Building, 17 Quincy street, Chicago, has been made the United States agent for George Cradock & Co.'s celebrated cable, which is in use on so many cable roads in this country. The factories at Wakefield, England, are full of work, and the Lang patent rope is not the least of the business.

Electric car  
Big hurry,  
Team on track  
Causes worry,  
Motorman,  
Great yell,  
Big foot,  
Broken bell.

THE Brown Electric Company, Boston, has closed the following orders during one week in May, calling for complete overhead equipment: Six miles for the North Weymouth Street Railway; 5 miles for an extension of the Quincy & Boston, and 10 miles for the Norwalk,

Conn., Street Railway Company. The Brown equipment is making a splendid record and the trade is growing in every department as is shown by the seven days' sales just noted.

THE Lewis & Fowler Manufacturing Company, of Brooklyn, is still doing its accustomed large business. Its specialties in the line of trimmings have long been well known, while fare registers, sweepers and headlights are turned out at a surprising rate for these hard times. The L. & F. specialties have long been known and will be longer known as the foremost in the country.

THE Wallace Electric Company has placed on our desk a handsome model of Wood's improved combination pole bracket, which is intended to furnish a flexible suspension for trolley hangers with bracket construction. The hanger is placed on a short piece of span wire stretched across an oval frame at the extremity of the bracket. It is a very neat and strong device.

building plant. The company has five 10-bench open cars with closed ends and one 25-foot box car for sale at a discount. These are uninjured.

CHAS. S. FOSTER, well known as the mechanical engineer of the late World's Columbian Exposition, Chicago, announces that he is prepared to carry on a general engineering business, with offices at 1411-1412 Manhattan building, Chicago. Mr. Foster's excellent opportunities for studying the subject, and the magnificent success of his department at the World's Fair, point to his immediate success in this new venture.

THE Charles Munson Belting Company, Chicago, reports improved trade with a goodly number of contracts for large belts, and a large number of complete belt equipments. Arrangements have just been completed with the L. M. Rumsey Manufacturing Company, of St. Louis, to handle the different brands of Munson

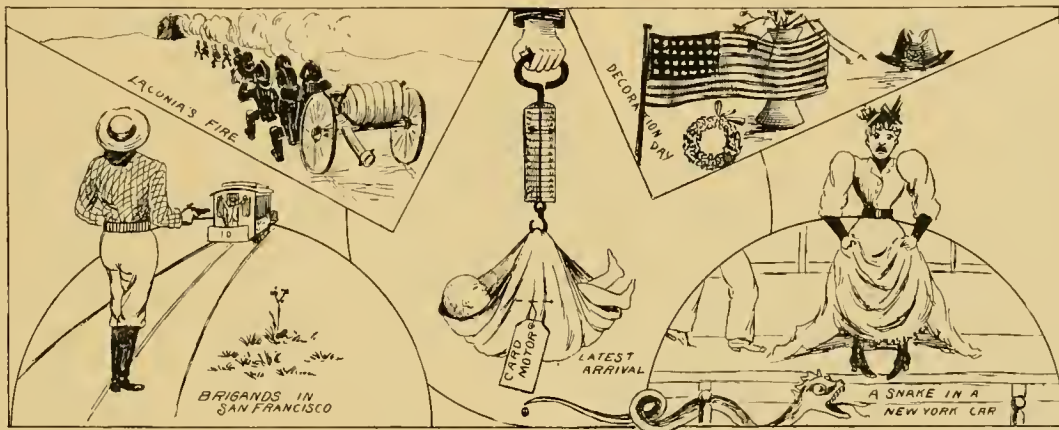

At a recent meeting of the directors of the Peckham Motor, Truck & Wheel Company, the resignation of A. W. Field, as vice-president and director of the company, was received and accepted. H. C. Soop, of Kingston, N. Y., was elected to the vacancies thus created. Mr. Field takes charge of the Boston office of the company and will fill the position with the same ability he has shown in the past.

CHARLES A. SCHIEREN & Co., of New York, are making two 54-inch double belts for Allentown Traction Company, Allentown, Pa.; two 54-inch double belts for City & Suburban Railway Company, Baltimore, Md.; and have just shipped two 32-inch double belts for Richmond Light, Heat & Power Company, Richmond, Ind., and 50-inch double belt (second order) for the Steinway, Railway Company, Astoria, L. I.

The Ellis Car Company plant, of Amesbury, Mass., which was destroyed April 28, included in the loss ten box and fifteen open cars. The heavy wagon business of the company has been removed to the factory on Friend street, and it is not yet decided to rebuild the car

belt in the southern territory, and with the Revere Rubber Company to have a full line of different brands of Munson belt in stock at their San Francisco and Minneapolis houses.

THE McLean Armature Works, 197 South Canal street, Chicago, has reorganized. James McLean, George F. Heald and John S. Parmele have formed a copartnership and will continue the business under the name of McLean Armature Works, as heretofore. The accounts due the late firm are now payable to the new firm, and all debts or obligations of the old firm are assumed and payable by the new partnership.

THE Breese & Mansfield Company, of 1120 Betz building, Philadelphia, have taken an agency for the Walker Manufacturing Company of Cleveland and will represent their interests. The company is composed of Charles P. Breeze, who was formerly connected with the Hall Signal Company, and Frank Mansfield, whose connection with the General Electric, is well known. The combination is a strong one and will make a most excellent representation of the Walker interest.

THE Steel Motor Company, Cleveland, O., has secured the contract for sixty double car equipments of steel clad motors from the Nassau Electric Railway Company, of Brooklyn, N. Y. The order was secured on the strength of the excellent record made by the Steel at Allentown, Pa. The company is now building a fourth order for the Lehigh Valley Traction Company. Considering the short time the motor has been on the market, this is an excellent record.

THE ten motors furnished the Electric Traction Company of Philadelphia by the Curtis Electric Company have not met the expectation of the railroad people, and after quite an extensive trial the cars have been run into the barn and equipment ordered removed. The trouble seems to be the inability of the motors to make running time on account of losing so much time in starting, so that with frequent stops it is impossible to get under good headway between blocks.

#### TWO WISE MEN.

"As soon as my trade picks up a bit,"

Said the merchant, looking wise,

"As soon as my trade picks up a bit

I am going to advertise."

"As soon as my field of grain is grown,"

Said the farmer, sore in need,

"As soon as my field of grain is grown

I am going to sow the seed."

THE Jackson & Sharp Car Company, Wilmington, Del., has recently contracted to build cars for the Fairhaven & Westville, of New Haven, Conn.; the Fairport & Westport, of New Bedford, Mass.; the Buffalo, Tonawanda & Niagara Falls and the Derby, Conn., and the Hartford, Conn., street railways. Orders for the Philadelphia Electric Traction and the Pottstown, Pa., Street Railway Company have been delivered. They are elegant and substantial cars.

THE Simplex Electrical Company has made a change in its western business, by which George Cutter ceases to act for it, and H. R. Hixon, who has for some time been connected with Mr. Cutter in handling the simplex goods, becomes western representative. Mr. Hixon has a host of friends who will gladly aid him in his effort to push the simplex. A stock will be carried here from which prompt shipments can be made. Mr. Hixon's offices are 1137 and 1138 Monodnock building, telephone Harrison 305.

A NEW electrical appliance company has been formed at Grand Rapids, Mich., to exploit the invention of D. Fred Sweet for a device for the protection of motors. The officers of the company are: President, D. Fred Sweet; vice-president, Samuel Barnes; secretary, Charles H. Annin; treasurer and general manager, Chas. Kritzer. The officers are all men of experience and enterprise.

Mr. Sweet is the inventor of the appliance. Mr. Barnes is superintendent of the electrical construction department of the Street Railway Company. Mr. Annin is a member of the firm of J. C. Herkner & Company, and Mr. Kritzer is the general manager of the Butterworth & Lowe Manufacturing Company.

THE following "blind" notice appeared in a New York street railway publication: "A receiver for the McGuire Manufacturing Company of Chicago has been applied for through Richard B. Davis, of Petersburg, Va., counsel for the company." Unless cognizant of the circumstances the reader might think that the receiver was asked for the McGuire Company, whereas it was the McGuire Company that asked for a receiver for the Railway Company. The high standing and unquestioned credit of the McGuire Company places it among the foremost concerns in street railway supplies, and the item would be recognized as a mistake by all except those who are not acquainted with the company.

THE United Tramway Sprinkler Company, of Louisville, are meeting with good success and have just closed contracts for their system in Portland, Ore., Salt Lake City, Atlanta, Ga., and Paterson, N. J. Their equipment is operating very successfully where already introduced, and the local companies formed to operate on railway tracks are showing large earnings and consequently good dividends. The street railways also come in for a handsome rental for use of tracks and power. Managers who desire to promote the comfort of their patrons by well sprinkled streets, and to save money in accomplishing this, cannot do better than look into this method which has proved such a success in Davenport, Rock Island, Albany and Troy, N. Y., Louisville, Chicago, and elsewhere.

THE Genett Air-Brake Company means business. It has arranged to push its air-brake very actively in this market and the factory has been equipped with additional machinery, whereby the daily output is greatly increased. The brake is highly efficient and acts smoothly and promptly. In these days of high speed and frequent stops the motormen find it indispensable. A simple turn of a handle suffices to stop a heavy train of motor and trail cars. This leaves the motorman free to use his hands. The emergency stop brings the train to a standstill in a short space without damage or jar. The brake is in use very largely on the Third Avenue line, New York, and the Atlantic Avenue Road, Brooklyn, Buffalo Railroad Company, and other roads in this country. The equipments sent to Australia, Brazil and elsewhere are doing well. The company's new catalogue contains very interesting matter and is a valuable addition to the library of a railway manager. M. L. Rothschild continues the management in Chicago, and the company has just arranged to have E. J. Wessels act as its eastern manager. His office is at 33 Wall street, New York. In such able hands the company's interests are assured.



SOME SMITH CAR LIGHTING.

It is not worth while to speak of the value of the specialties made by Smith, of New York, because they have long been known to the street railway men of the country as first class in every respect, and because the many friends of the company would feel insulted if it were intimated that the Smith goods were not of national, nay, of international fame. For thirty years the Smith lights have illuminated the street railway cars of America and Europe, improving with the advance of street cars, and keeping pace with the demands of the times.

On the subject of headlights, Smith of New York has something to say. A good headlight means a great deal. It means safety and economy, and it means comfort for the employes and the public. Cheap headlights may be bought, but they are of cheap material and cheap workmanship, and every manager knows that reliability and strength are the chief requisites of a good headlight. Such is the new Number 25 headlight, shown in the engraving. It is sold at a price that is as low as is consistent with reliable goods. It is strong, powerful and economic. The elegant cluster electric chandelier shown

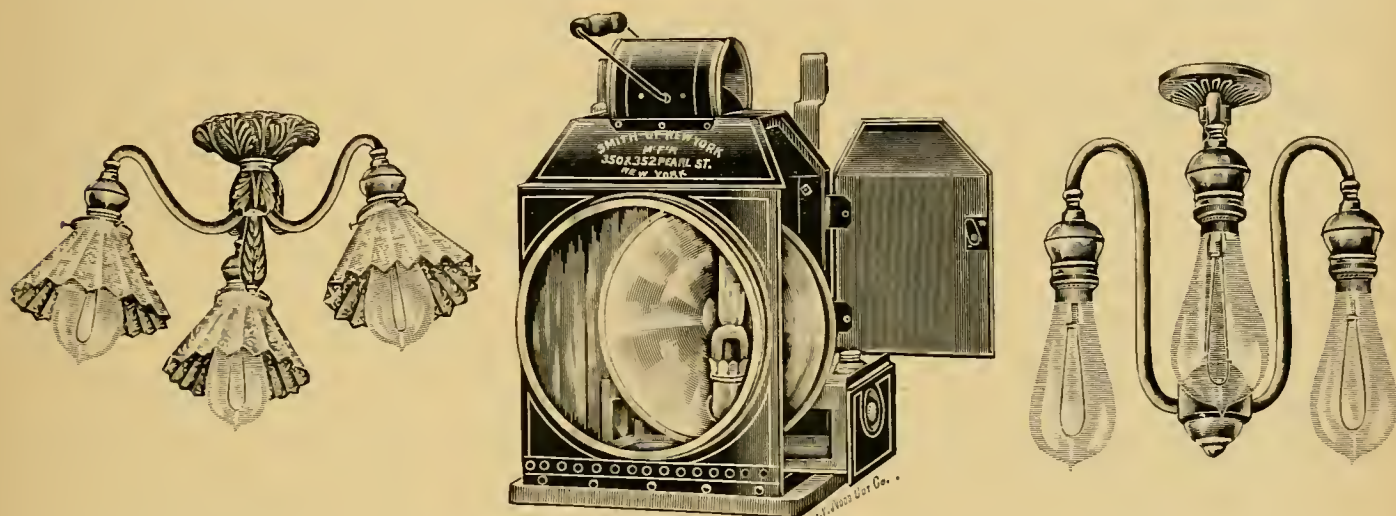

is a light to the world and a joy for a long time to the user. Elegant in appearance and good wearing qualities, another form is also shown, for three globes with shades. Nothing adds to the appearance and comfort of a car so much as an elegant chandelier, and the Smith make speaks for itself.

Charles Smith, the manager of the company, has been known, man and boy, for so many years, that we refrain from making further mention of him than to say that he is still at 350-352 Pearl street, New York, ready to treat all comers, whether customers or not, with the consideration and cordiality for which he is noted.

PHOTOGRAPHY as a means of detecting weakness in bridges has been used in England. A kodak shot was taken at the bridge before a train rushed over it and another film exposed as the train reached the middle of the structure, the camera remaining in exactly the same position. The two photographs compared showed a dangerous deflection in the bridge.

MARRIED.

Vice-president Arthur W. Field, of the Peckham Motor, Truck & Wheel Company, Boston office, and Miss Work, of Moberly, Mo., were united in marriage at Kansas City, May 17. The many friends of the groom in street railway circles unite in the REVIEW'S felicitations.

CHAS. A. SCHIEREN & Co. have sold 75 feet of 34-inch double, perforated electric belting to the Metropolitan Electric Railway of San Francisco.

A BROOKLYN, N. Y., motorman saw a thief snatch a lady's purse and start out on a dead run along the route of the cars. The motorman speeded up his car, caught up with the thief and sat on him while the conductor called the police. When the thief saw the car approaching he panted, "Huh! Huh! I believe that d——d motorman was tryin' to catch me. I'll have him broke. He didn't have no right to run his car that fast." After this purse-snatchers will not run up streets occupied by the trolley line.

JAMES HOPKIRK, of 26 Turk street, San Francisco, has invented a reversible driving gear for cars driven by gasoline motors under the seats. It enables the motors to have a constant direction of rotation while the car can be reversed.

California in Three and One-Half Days.

If you are going to California and desire to make the journey in the most economical, quick and comfortable manner, purchase your ticket via. the Chicago & Northwestern, Union Pacific and Southern Pacific Railways. Pullman drawing-room sleeping cars are run from Chicago to San Francisco without change, in three and one-half days. Completely furnished tourist sleeping cars are also run in which accommodations can be procured by passengers holding either first or second-class tickets at a cost of only \$4 per berth from Chicago to San Francisco and other California points. The hour of departure of trains from Chicago affords prompt connections with all trains from the east and south. Variable route excursion tickets, allowing nine months' stay in the health-giving climate of California, second-class tickets of low rates, sleeping car reservations and full information can be procured of any ticket agent, or by addressing W. A. Thrall, General Passenger and Ticket Agent, Chicago & Northwestern Railway, Chicago.

## HALF FARES.

Interesting Bits of Information from all Parts of the Country,  
Boiled Down for Busy Readers.

THE Niagara Falls, N. Y., Street Railway Company has put a steam fire alarm whistle on its power house.

THE electric road at Terre Haute gives free band concerts Sunday afternoon, in the park, and hauls a large volume of business in consequence.

THE Lake Roland elevated, of Baltimore, Md., carried 4,652,000 passengers during its first year, ending May 7. Not one was killed or seriously injured.

GENERAL MANAGER C. D. WYMAN, of the Milwaukee Street Railway Company, finds that the cars on his system travel 20,000 miles a day and 8,000,000 miles a year on 125 miles of track.

THE Terre Haute, Ind., street railway motormen are required to wear dark blue sweaters, instead of coats, in the summer. This gives more freedom to the arms and the artistic effect is not bad.

THE estate of the late Hoadley B. Ives, of New Haven, Conn., president of the New Haven & Westville Street Railway Company amounts to \$800,000. He was thought to have been a multi-millionaire.

THE Wild West Show management, of San Francisco, is used as a pleasure resort by the Market Street Railway. Coupon tickets for ten cents admit the passenger to the grounds and gives him a ride to the place.

A UNIQUE feature of the real estate firms' methods of booming a Boston suburb is the granting to each purchaser of a lot, a five-year pass on the Lynn & Boston Electric Railway, paid for, of course, by the real estate men.

GOVERNOR FLOWER has vetoed the bill repealing the law which allows the superintendent of public works to grant permission to electric companies to trolley the canals of the state. The governor heartily favors electricity.

HOUSTON, Tex., young men have begun this summer to charter an electric car and take a three hours' ride over the system. Young ladies accompany them, and with banjo, guitar and song the occasion is very interesting.

THE Kalamazoo, Mich., Street Railway Company, at its recent annual election, named the following executives: Theo. P. Bailey, president, Chicago; Geo. J. Kobusch, vice-president, St. Louis, Mo.; Jas. W. Johnson, treasurer, Chicago; E. E. Downs, general manager, Kalamazoo. Mr. Downs succeeds G. K. Wheeler, as general manager. The officers were well pleased with the city and predict a bright future for the road.

GENERAL MANAGER A. BAUMAN, of the Lancaster, O., Street Railway, is at work on a scheme to build an inter-urban from Lancaster to Baltimore, O., and Buckeye Lake Park. The last legislature passed a bill making the latter place a national park.

IN the case of Miss Lyon, of New York, which attracted so much attention from her refusal to allow a personal examination by doctors, with a view to ascertaining the validity of her claims, the Court of Appeals has held that she need not do so, and that the law is unconstitutional.

THE first electric car over the One Hundred and Thirty-fifth street line, New York City, was run on trial May 7. President E. A. Mayer, Superintendent James Corrigan and Electrician Frank Wardlaw made the initial trip. This is the first line of the famous "Huckleberry" system.

THE piston head blew out of the engine of the City Passenger Railway of Baltimore, recently. The cylinder pressure at the time was 120 pounds and the cylinder itself measured 24 by 60. The accident, fortunately, caused little damage. It is thought that a piece of one of the valve seats became loosened and slipped between the rod and cylinder.

A LYNN, MASS., alderman is promoting a project for equipping an electric car with hose and reel for fire fighting. This car may be run out on the tracks to any place within reach of the electric line and make better time than the regular engines. Although nothing definite has been done, the idea is worthy of elucidation. Chemical engines might be so carried.

LOUIS KARSGARD, a driver on the Bridge line between Davenport, Ia., and Rock Island, Ill., recently committed suicide. He was appointed as conductor of the new electric line, but the thought of the suspension of the old horse car service so preyed upon a sensitive and unbalanced mind that he died by his own hand, heart-broken. Tally one more for the deadly ———.

ONE of our subscribers who commenced with the first issue, and who is interested in an excellent car fender, accompanies his annual remittance with the following:

To serve the present age,  
My calling to fulfill—  
Oh may it all my powers engage,  
And pay your little bill.

My fender is the same in principle—different in form.

GENERAL MANAGER WYMAN, of the Milwaukee Street Railway Company, has condemned the double-decked car to oblivion, as far as Milwaukee has to do with it. They are too dangerous, Mr. Wyman says. Besides causing the greatest inconvenience to passengers, conductors, while climbing on the roof after fares, are unable to look after their cars properly and the danger is very great.

## NEW HAVEN CAR REGISTER.

Though this register has been on the market now but only thirteen months, it has pushed steadily to the front and has achieved a record of which any company might well feel proud. It has been adopted and is now in satisfactory use on more than one hundred lines in this country and abroad, prominent among which are the Philadelphia Traction Company, the Rochester Railway Company, the Toronto Street Railway Company, the Montreal Railway, and the North Hutchinson County Railway. The management has been progressive from the start, and in addition to the excellence of the machine a strong executive force has had largely to do with bringing its merits before the street railway men of the country. General Manager Boyd is an indefatigable worker and has made many friends among the fraternity.

## NEW PUBLICATIONS.

THE Craghead Engineering Company, of Cincinnati, has issued its 1894 catalogue, showing a full line of electric railway overhead parts.

THE ECHO is the catchy title of a new and attractive 8-page weekly, published by the employes of the West End Street Railway, Boston. It is filled with interesting local matter, and reflects much credit on its makers. H. H. Perry is editor, E. S. Goff associate editor, and J. D. Main business manager.

MODERN TURRETT LATHE PRACTICE is a very artistic monthly publication, issued by the Gisholt Machine Company, of Madison, Wisconsin. It really deserves the name of an album, so fine is the engraver's work. It will be mailed regularly to those who desire it, and will prove a handsome addition to any mechanic's library.

THE Shiffler Bridge Company is furnishing those interested in such things with an album of designs comprising 140 pages of elegant half tone engravings of buildings built by this company in various parts of the United States. Both the book and the buildings are a credit to the concern, and display a great variety of designs, together with resources possessed by few companies in the business.

"THINGS ARE NOT ALWAYS WHAT THEY SEEM," is the title of a little work published under the auspices of the Goodrich Hard Rubber Company. It is one of the most original ideas ever incorporated into a trade catalogue or circular, and is well worth perusal for the "fun" there is in it. It illustrates the various hard rubber products, with an order letter under each giving the layman's idea as to what they are for.

LIPPINCOTT'S MAGAZINE, for June, has an unusually interesting table of contents, in which is seen announced a complete novel by M. G. McClelland, entitled the Wonder Witch. Under the heading, "Sea Island Cot-

ton Respun," Dora E. W. Spratt tells how those islands, with their simple population, passed under Northern care in war times. In "The New Northwest Passage to the Orient," J. Macdonald Oxley, writes of the Canadian Pacific Railway and its line of steamers to Japan.

THE Chicago Electric Truck Company find enquiries numerous.

THE Chicago Rawhide Manufacturing Company, of 75 East Ohio street, Chicago, even during the hard times has been busy manufacturing rawhide dynamo belting, sometimes running a double shift.

SUPERINTENDENT WALKER, of the Sioux City Street Railway Company, has a proposition from a Cleveland, O., electrical manufacturing concern that desires to manufacture and handle his patent trolley wheel on a profit sharing basis.

THE Mekarski compressed air system in use at Berne, Switzerland, and other places in Europe, has just been installed on the Woronoco Street Railway, of Worcester, Mass. The system is being introduced by James F. Lewis and Addison C. Rand, of the Rand Drill Company.

DR. WILLIAM T. BARNARD, past president of the Alley Elevated, Chicago, died May 10, at Washington, D. C., at the age of 45, after an honorable career in governmental service and distinguished success in railroad lines, as well as in his profession. His attainments were varied and his success in all his efforts was remarkable.

THE NEW CASTLE CAR MANUFACTURING COMPANY, of New Castle, Pa., since its machinery building was destroyed by fire, has constructed a new building for the machinery plant, with brick and iron boiler and engine house, and a new painting and finishing room 150 by 40 feet. The M. A. Green engine has been placed and a complete line of new wood-working machinery installed. The shops are again running under full headway.

AMONG the sales from the New York office of the General Electric Company for the second week in May are found the following items: 450 motors to the Brooklyn, Queens County & Suburban Company; 60 motors and generator to the Bridgeport, Conn., Traction Company; 20 motors to the Danbury, Conn., Street Railway; 20 motors and generator to the New Haven, Conn., Street Railway; to the Franklin, Pa., Street Railway 6 motors, and to the Electric Traction and the People's Passenger railways, of Philadelphia, large marble switchboards.

C. K. KING, manager of the Ohio Brass Company, has just returned from the East, where he has established agencies for that company's goods with Walker & Keply, Philadelphia, Brown Electric Company, Boston, Charles E. Chapin, New York, and Alfred Ely & Company, Baltimore.

### TESTIMONIAL TO WILLARD A. SMITH.

A fitting but fully deserved testimonial was the beautiful memorial vase, presented the chief of transportation department of the Fair. It was the gift of the American exhibitors; was made by Tiffany & Co., and is said, with one exception, to be the finest specimen of art metal

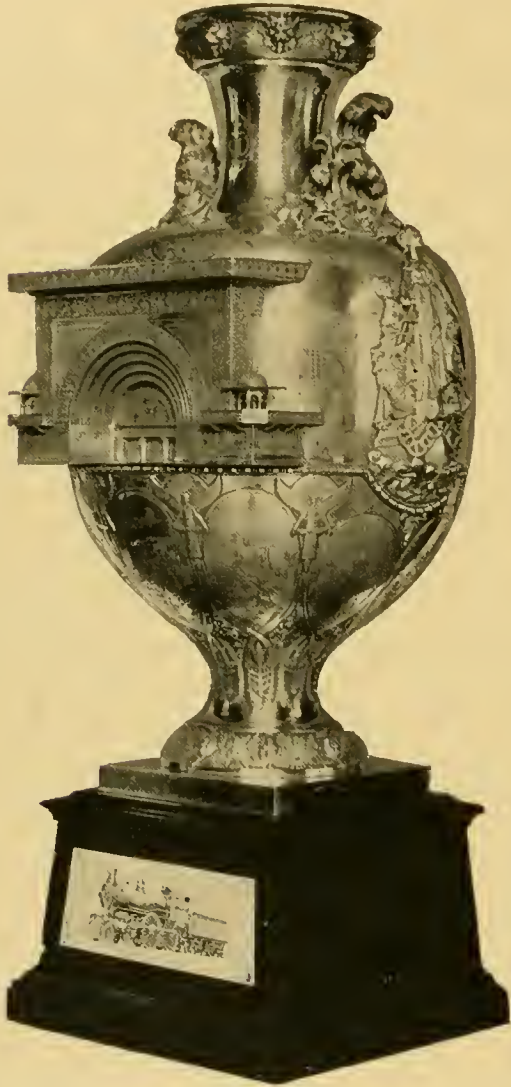

work produced in this country. It is of silver and represents upon its surface the history of transportation. Mr. Smith's pleasure in thus being so notably honored will have to be large if equal to the genuine good will which prompted and created this noble souvenir.

F. A. SCHEFFLER, who has been connected with the Stirling Company for the last year as its sales agent in New York, has gone to Boston, where he will co-operate with J. Bradford Sargent, the New England representative of the Stirling Company, in his efforts to bring the Stirling more prominently before the steam users of that section. John MacCormack, who is very well and favorably known to the boiler trade throughout the East, succeeds Mr. Scheffler as manager of the New York office of the Stirling Company.

THE genial George E. Pratt called on the REVIEW recently, fresh from victories of the Jackson & Sharp Car Company, which he now represents. Mr. Pratt has been eminently successful in his new connection, as recited elsewhere in our trade notes.

E. J. WESSELS, formerly manager for the Short Electric Railway Company, will handle the business of the Genett air brake in the East. His long experience and wide acquaintance will make his services specially valuable, and his many friends will wish him the success he is sure to achieve.

ADOLPH SUTRO, the capitalist, and the Southern Pacific's street railway syndicate, have been having a lively time at St. Francisco. The Cliff House, Sutro Heights, has always been a popular resort, and it is owned by Mr. Sutro. A fare of ten cents has been instituted by the railway company, to the resort, which materially diminishes traffic. After much logic and many conferences nothing could be done with the railway company, so Mr. Sutro takes heroic measures and builds a high board fence around his property, shutting out both view and traffic. The public will not care to view a dead wall covered with soap advertisements, and so the road is expected to lose money or come to a five-cent fare.

CHAS. J. MAYER, 600 Betz building, Philadelphia, is meeting with continued good success, and reports a constantly increasing business. The Nuttall specialties are much sought after, and Mr. Mayer's long experience with the wants of railway men enables him to know just what is required. The Macallen sheet mica is also handled by Mr. Mayer.

THE Hubley Manufacturing Company, of Lancaster, Pa., are rapidly making themselves known and felt as one of the most progressive supply houses in the trade. And they can show a record, too. Trolley wheels of their make, having made 10,000 miles, are still going, with a good start on the second ten thousand. In harps, they lay special stress on their light and strong construction, and as being very low priced. Motor and dynamo bearings of their make are guaranteed to give 20 per cent longer life than any other. In overhead fixtures they make a complete line. Users speak very highly of the Hubley supplies.

### Custer's Last Battlefield.

A visit to this spot, which is now a National Cemetery, is extremely interesting. Here, seventeen years ago, General Custer and five companies of the Seventh U. S. Cavalry, numbering over 200 officers and men, were cut to pieces by the Sioux Indians and allied tribes under Sitting Bull. The battlefield, the valley of the Little Big Horn, located some forty odd miles south of Custer, Montana, a station on the Northern Pacific Railroad, can be easily reached by stage. If you will write Chas. F. Fee, St. Paul, Minnesota, inclosing four cents in postage, he will send you a handsomely illustrated 100 page book, free of charge, in which you will find a graphic account of the sad catastrophe which overtook the brave Custer and his followers in the valley of the Little Big Horn, in June, '76.



## A CABLE RAILWAY ON THE ICE.

The Amphibian of Duluth and Superior.—Crossing Cold Superior on the Ice.—An Unique Idea.

The REVIEW has in its day illustrated a number of unique forms of transit, some practical and some only curiosities. To the practical category, however, belongs the idea brought out in the story of the Duluth-Superior ferry barge, last winter, and which was the joint idea of that competent and progressive street railway man, H.

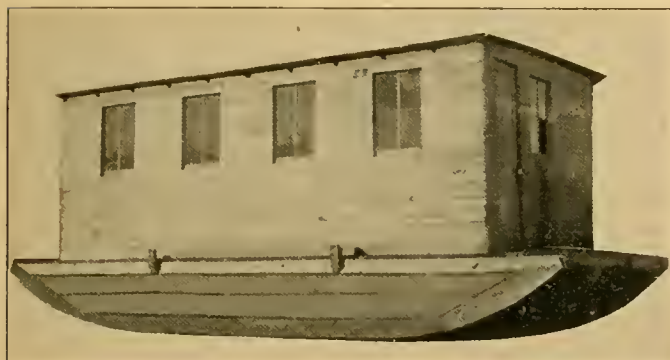

THE ICE FERRY SCOW.

M. Sloan, superintendent of the Superior Rapid Transit Company, Superior, Wis., and A. C. Majo, a bright marine designer.

The details of the matter were placed in the hands of A. C. Majo, who forthwith began to devise a means of giving street railway passengers a continuous trip, both summer and winter, across the icy waters of the bay, dividing Duluth, Minn., and West Superior, Wis. The present article described is the means of winter passage.



Mr. Majo says, in relation to the work: "Though a sailor by profession, with the trackless deep as a right of way, and while I have seen times when joints were low and the whole roadbed needed surfacing badly, still I presume any novelty connected with passenger transportation will be of interest to REVIEW readers."

"While engaged in the ferry service between Connor's Point, Superior, and Rice's Point, Duluth, it occurred to me that the service could be continued throughout the winter when the ice had formed and navigation was impossible."

Briefly, the idea was to provide a scow with a cabin and a pair of runners, using a cable as a motive power. This plan was accepted by the Duluth and Superior street railway managements and the construction of the scow begun. The plan was enlarged to admit of the use of the vessel in water during the times of bad ice in early spring, as well as on the hard surface in the winter time. It was regarded as possible, however, that its use as a sailing vessel would be limited, as judicious sprinkling of the roadway would render the ice thick and smooth enough to keep up the weight a little time after the surrounding ice had yielded up part of its strength to spring-time's approach. After this date of course, regular ferry business between the cities would be resumed.

The scow, an engraving of which we present, is 10 feet wide by 26 feet long by 34 inches deep. Six truss gunwales of 4 by 6-inch pine add strength; it is planked with 2-inch pine, with deck and all securely caulked and sheathed with iron. The cabin extends the whole width of the vessel, leaving three feet at each end for a platform. The runners are two in number and made of 4 by 6-inch oak, steel shod.

The distance between the two landing points is 1,200 feet, and to propel this amphibian a cable plant was improvised. The power plant was situated on the Superior side of the channel and consisted of two 20-horsepower motors geared to two 3-foot drums, or strictly speaking, to one drum, for the second mentioned served as the idler and also as a tension carriage, being set in a sliding bed, from the end of which was attached a chain which ran over pulleys to a weighted box. A sheave was set on the dock at the Duluth end for the terminal sheave. The cable used is an inch steel rope with the necessary carrying and guiding pulleys. This was all the

propelling machinery required. The rope was run over the deck of the scow, which is provided with two simple screw grips, one at each end of the boat, to control the motion.

After a few alterations the boat started regular trips the first of January. On March 15th, the ice gave way at a point 1000 feet from the Superior shore. This was the anxious moment, but the amphibian did all that was expected of her, by sliding from the ice into the water, crossing the water and mounting the ice again, without a hitch. The break in the ice extended 150 feet and from

that point to the shore the ice was three feet thick and solid to within 200 feet of the Duluth landing. It was thought afterwards advisable to cut a channel from one side to the other, but it was soon found that the floating ice was a graver danger than the jump from ice to water. Then, too, the passengers had become used to these leaps and did not consider them objectionable. In a short time the boat broke through again on the Duluth side, so that the ferry was in and out of the water twice each half trip. On account of the heavy float ice the ferry had to be pulled off a few days before the regular boats began running. The last winter was an exceptionally open one, and Mr. Majo is of the opinion that ordinary winters will find the amphibian a great convenience to the inhabitants of the two cities. Our sketch of the cable arrangement shows its simplicity and we think that the Superior and Duluth populace may be well proud of two such enterprising and ingenious citizens as Superintendent Sloan and Engineer Majo have proven themselves.

The success of the plan opens up a field, perhaps, for further experiment on the subject, and no doubt the coming year will chronicle a number of other applications of electric power to cable traction for ferry purposes.

#### DEATH OF JOHN H. DALZELL.

John H. Dalzell, one of the best known citizens of Pittsburgh, Pa., died at his home in Allegheny City, May 29. Mr. Dalzell was one of the earliest capitalists to invest in electric traction and was a large stockholder in several lines, as well as president of the Allegheny & Manchester Traction Company. Mr. Dalzell made his money in the early days of the oil business. He was a man of large public spirit, a college graduate and a business man of exceptional foresight and courage. He was connected with several manufacturing concerns and banks in an official capacity. He leaves a wife and two daughters.



JOHN H. DALZELL.

A RUNAWAY hog, at Louisville, Ky., recently made great diversion for the populace by lying down in a nice muddy puddle between the street railway tracks, and refusing to "git" when urged to do so by the owner. The pig weighed several hundred pounds, and the combined efforts of a dozen darkies were required to remove him.

#### ELECTRIC LAUNCHES FOR PLEASURE RESORTS.

Electric launches afford an excellent attraction for street railway pleasure resorts which are fortunate enough to have a body of water on which to operate them. Probably this has occurred to a great many superintendents who saw the electric launches gliding over the lagoons at the World's Fair last summer. The opportunity now offered by the General Electric Launch Company for the purchase of a number of those in use at the fair by street railways will doubtless be taken



advantage of by a number of companies. These launches can be charged from the railway's own circuit or any other source of electric power. The boats are staunch and can ride in quite rough water. They seat 30 passengers and can be run all day on one charge, which can be given at night. The length over all is 36 feet; the beam is 6½ feet and when loaded they draw 30 inches of water. They require less care than other mechanically propelled boats, besides being vastly more attractive and neat. The appearance at night, when electrically lighted, is in itself enough to settle any doubt as to this. They ought to be a good investment.

THE extension of the Liverpool elevated railway to Seaforth was inaugurated last month.

THE Barmen, Germany, town council has decided to compel the Elberfeld-Barmen street railway to put in electric traction.

WILBUR B. ALLEN, the genial and popular representative of the Brownell Car Company, spent several days in Chicago last week.

THE Independent Electric Company, Chicago, has issued a neat pamphlet, giving descriptions and price of the Independent trolley marketed by the company.

THE Berlin Iron Bridge Company has the contract for the power station of the Electrical Association of Waterbury, Conn. The building will be 66 by 183 feet, brick, with a Berlin patent anti-condensation roof.

O. W. RUSSELL, advertising manager for the Link-Belt Machinery Company, has issued an attractive catalogue of the Link-Belt manufactures. It is one of the best arranged that has come to our notice.



WINDSOR & KENFIELD,

PUBLISHERS AND PROPRIETORS,

269 DEARBORN ST., - - - CHICAGO.

Published on the 15th of each month.

SUBSCRIPTION, - - - TWO DOLLARS.

FOREIGN SUBSCRIPTION, - - - 20 SHILLINGS.

Address all Communications and Remittances to THE STREET RAILWAY REVIEW,  
269 Dearborn Street, Chicago.

H. H. WINDSOR,  
Editor.

F. S. KENFIELD,  
Business Manager.

**CORRESPONDENCE.**

We cordially invite correspondence on all subjects of interest to those engaged in any branch of Street Railway work, and will gratefully appreciate any marked copies of papers or news items our street railway friends may send us, pertaining either to companies or officers. Address:

THE STREET RAILWAY REVIEW,

269 Dearborn Street, Chicago.

Eastern Office, Room 14, No. 126 Liberty Street, New York.

This paper member Chicago Publishers' Association.

Entered at the Post Office at Chicago as Second Class Matter.

VOL. 4.

JULY 15, 1894

NO. 7.

**Contributions.**—*Subscribers and others will materially assist us in making our news accurate and complete if they will send us early information of events which take place under their observation, such as changes in railroad officers, organizations and changes of companies in their management, particulars as to the business of the letting, progress and completion of contracts for new work or important improvements, experiments in construction and operation, and suggestions as to improvement. Discussions of subjects pertaining to ALL DEPARTMENTS of street railroad business, by men practically acquainted with them, are especially desired. Officers will oblige us by forwarding early copies of notices of meetings, elections, appointments, and especially annual reports, some notice, of all of which will be published.*

THE "vestibule" law has been declared by the supreme court of Minnesota as constitutional, and it is to be expected that the electric cars of the twin cities will be adorned accordingly next winter.

ANOTHER argument in favor of electricity for elevated roads. A little girl walking beneath the elevated road in Brooklyn was burned to death by her dress catching fire from a live coal dropped by a passing train.

THE Michigan Central Railroad is crossed by an electric line at Saginaw. When the trolley wire was hung the railroad notified the electric people to raise the wire from 22 to 24 feet, and on their failure to do so, executed a threat to cut the wires, doing so at a time of day most inconvenient to the street railway. Suit was brought for damages, which have been allowed in the supreme court of the state.

BALTIMORE is one of the most "legislated" street car cities in the country, and as may well be surmised, the result is productive of little benefit to the public and much annoyance to the roads. The latest is an order requiring cars or trains not to approach nearer than 50 feet to the one ahead. As the electrics are 28 feet and the cable trains 52 feet in length, it is readily seen that under the rule the former must occupy not less than 78 and the latter 102 feet of street. In the business portion of the city this cannot fail to work much hardship, not only on the company, but cause serious inconvenience to the public.

BIDDING on engineering contracts in Egypt does not seem to meet with much favor among English manufacturers. Only recently an English contractor has brought suit for the recovery of \$10,000, forfeit money, put up with his bid, for constructing the street railway at Cairo. The facts seems to show conclusively that the contractor kept his part of the bargain to the letter, but the official authorization of the Under-Minister of Public Works was dishonored by the Mixed-Tribunal—whatever that august body may be—and the contractor lost his case, and his money. American builders thinking of bidding on the Cairo tramway will do well to insert a clause providing for "cash in advance."

THE past month has seen the signing of the contract for the electrical equipment of the Metropolitan Elevated Railroad of Chicago. This equipment will be the first real invasion of the steam locomotive field by electricity. The contract, which was awarded to the General Electric Company, calls for two 1,500 kilowatt and two 800 kilowatt direct connected generators, and 55 motor cars, with two 100-horse-power motors each. These motors will be sufficient to operate three car trains, and as the traffic requires longer trains in the future, the number of motors will be increased to four to a car. There is reason for gratification in the fact that so strong a company as the Metropolitan has made this move, and we predict that the use of electricity will be even more satisfactory than was anticipated in the same way that electric surface traction developed unthought of advantages.

How so elaborate a publication as the REVIEW can be furnished for two dollars a year is a frequent query from our readers. We cannot better answer than to quote from that brainiest of American lady journalists, who, in her "Kate Field's Washington," says:

"If you are a scrupulous person, you will always read all the advertisements in the back of your magazine, as it is on the supposition that you will do this that you get it at a price below the cost of production."

Aside from any obligation which the reader of an expensive publication at a low price may have, our advertising pages will be found extremely valuable reading, representing everything new and advanced in operative practice, and including all the best and most progressive manufacturers. It is an almost daily occurrence

for managers to write or tell us they peruse the advertising pages with the same care and thoroughness which they bestow upon the reading articles.

THERE are times in the development of every science or industry when a large number of inventors are induced to work simultaneously on the same problem, and, public opinion to the contrary notwithstanding, there will invariably be a number of men who arrive at the same results at about the same time. It is now an utter impossibility to establish in the courts fundamental patents on any class of apparatus which has been worked upon simultaneously by a great many able inventors. The man or company that is first in the commercial field with any new apparatus is invariably the one that is successful, provided of course that business ability is present and the apparatus is not a manifest infringement from the start. The swarm of devices brought to light by the fifty thousand dollar Metropolitan prize bids fair to result in innumerable conflicts of claims in the patent office as to priority of invention.

A CHICAGO daily paper takes exception to the use of the word "lady" as used by conductors in addressing female passengers. The word is probably used unnecessarily by some employes, but there is an absolute need of some such word and we would meekly inquire what word can be used in its place? "Madam" would bring down the wrath of the young lady patrons, and "Miss" would have a like effect when wrongly applied or addressed to some maiden ladies of forty. There is one term, however, that is sufficiently broad and which we would recommend to the daily in question. "Woman" has a sanctimonious scriptural sound and would be very effective on some occasions. "Woman have a care," "woman make haste," or "woman arise, this is Twenty-first street," if delivered with the proper dramatic inflection, would create a small revolution in modern street car travel and tend to relieve a journey of its monotony.

THE Omaha city council had an attack of the slow speed ordinance, and things looked very hopeful, from the council point of view, of its becoming a law. When interviewed on the subject, Manager Smith was radiant. Hadn't been under the impression that it was such a good thing, but now his attention was directed to the matter, wondered why he had failed to comprehend the beauties of the scheme long ago. In fact, he was greatly taken with the plan. This emphatic declaration of harmonious opinion was a poser to the aldermen, but it wasn't a circumstance to the row raised the next morning, when every car in the city crawled along at exactly two miles an hour. And they did it all day, and the next day; and when the frenzied populace let up on the aldermen, it was quite unnecessary for Manager Smith to even attend the council meeting when the ordinance came up, and promptly went down again—into the waste basket.

ACCIDENT insurance has proved alike unsatisfactory to street railways and the companies which accepted their risks. As set forth elsewhere in this number, it is one of the most difficult and uncertain matters to fairly estimate the proper premium in any special case. What constitutes a good basis of estimate in one city utterly fails in another, and so after vigorously inviting the business for several years, the accident companies are now turning a cold shoulder. There are several reasons why insurance companies cannot handle this business as economically as the roads themselves. This is accounted for in several ways. With no insurance, employes are more careful. Witnesses will often consent to appear in court through friendship for employes, or on account of past or future favors from the road, who would otherwise profess ignorance of the facts, to avoid the annoyance of witness duty. Roads are more apt to discipline careless employes when uninsured than when no insurance is carried. Other reasons may be mentioned. The whole matter seems to simmer down to the proposition: Where a risk would be profitable for a company the road cannot afford it, and where it would be profitable for the road the insurance people do not care to take the business.

ONE of the most absurd moves ever made by a public official was recently made by the sheriff at Omaha. A suit for personal damages resulted in a verdict for \$5,500 against the company. After the case was tried in both the lower and supreme courts, the company discovered new evidence and tried to have the case reopened, but the supreme court refused, and a mandamus was handed down on which the attorneys for plaintiff got the sheriff to levy on some cars. The mandamus was presented for payment at the street railway office at a time when the officers were absent and the company knew nothing of the mandamus having been sent down. Meanwhile the sheriff levied on the cars in service at the most important point of the system, effectually blockading traffic for several hours during the rush of the evening. Public opinion naturally gave the sheriff a good "roasting." Finally an injunction was obtained against the sheriff and the cars returned to the company. The case was taken before the court. After a day's proceedings, the prosecuting attorneys, who raised the commotion, and the sheriff, got scared, and offered to pay damages and costs and allow the injunction to be perpetual against the sheriff if the street railway would pay the original judgment. This was done; the judge entered stipulations accordingly, and stated that this was about the way he would have decided it. The sheriff evidently wanted to cause all the inconvenience possible as there were plenty of cars in the barn. He and the attorneys have now had \$210 worth of spite, and we presume they do not care about taking any more until prices are lower.

ON a prominent interurban line crossing a river on a bridge nearly 100 feet above the water, a car struck a paving block which had fallen from a passing wagon,



derailing the rear truck, and before the car could be stopped, one truck had left the track and the end of the car crushed through the wooden railing and overhung the terrible abyss. As usual, the passengers made a wild rush for exit, and with great difficulty and considerable presence of mind, the conductor drove them back, fearing the increased weight thus massed at one end might overbalance the car body and hurl them all to destruction. Fortunately the car held the bridge, no lives were lost, and the material damage was repaired in a few hours. The occurrence, however, suggests dangers too great to be passed unnoticed. We find that while the bridge is ironed with a heavy T rail, there was no guard rail used, and that cars have been crossing at a high rate of speed. Had the accident fulfilled its possibilities, the consequences would have been simply awful, and in all probability resulted in as many fatalities as there were passengers. And in such event the company could not have been exonerated of blame. No road operating over perilous places, as this, has any right to neglect all reasonable and established methods of precaution. It was a small obstruction which derailed the car, but at any moment a wheel or axle might have given way, or any one of many unlikely circumstances happened, and with disastrous consequences. The lesson for us all is, that on high, exposed construction, strong guard rails be adopted, and that less speed and greater safety at such points will not be unsatisfactory to the riding public.

THE postal authorities, both general and local, are rapidly awakening to the importance of using street railway lines for a more rapid delivery of mails, especially in large cities, and smaller cities where the centers of population are scattered. The high degree of success which has attended all the attempts thus far made has been very satisfactory both to the department and the public, and the decision during the past month to adapt the system to Chicago and Brooklyn, again draws attention to the possibilities in other cities which have so far made no move in the matter. Where the local conditions and geography of the sub-stations permit, the carriage of mails should be secured at the earliest possible moment. And the man to study out and urge this is the general manager of the street car company, for the plan has very much to commend itself to him, and there can be few, and minor, if any, objections. While the revenue is not great, it is worth having, and even if the operation of mail cars brought no profit, there are other reasons which make them highly desirable. Fortunately, the question of expense to the department will not stand in the way of this desired advance, for the expense of haulage over rails in cars is not as great as the same and slower service as at present with wagons. It is to be hoped the institution of the street car mail service already in operation will be carefully studied and promptly taken up by all progressive street railroaders, and its general adoption achieved in the near future on many mechanically operated lines. For interurban purposes it is already

proving a great saving in time, and affording frequency and promptness in the delivery of mails to many points heretofore limited to one mail or less per day.

SO MUCH has been printed in the daily press of the country, descriptive of the great labor eruption, we need scarcely more than refer to the event, which a few months later will appear to the misguided strikers, as it has all along to thoughtful persons, as a phenomenal exhibition of want of common sense. Because a parcel of carpenters in a little town out in the borders of this city were unsuccessful in dictating to their former employer, they vent their spite on a generous public, and drag in thousands of well meaning workingmen, who have absolutely no grievance of their own, and who in many cases have deliberately broken faith and contracts made a few months since. That many such have gone out under duress, and had at heart no sympathy in the unholy cause, there can be no doubt. But having put their heads in the noose, they cannot complain when ambitious, ignorant and criminal leaders pull the rope and throttle them. The president of the United States has won the respect and confidence of all true Americans by his prompt and wise movement of federal forces to the suppression of mob rule, and the maintenance of the majesty and dignity of the law and the government. Chicago has been given her hour of greatest peril, and the state a disgraceful humiliation, to be contemplated only with shame, by the encouragement of riot and arson through the connivance of an office seeking mayor and an anarchist governor; neither of whom raised a rebuking hand until a dangerous foreign element had trampled upon the law and its officers, and insulted the flag. The attempt to further cripple the breast which nourishes them, by calling out the building and other trades, cannot fail of defeat. Already it is a failure. The street car men, of whom there are some 10,000 in Chicago, will not go out, Debs to the contrary notwithstanding. Others have already refused, and the bluff has fallen flat. Nor can it be otherwise, with three idle men for every one employed, even were the "strike order" not an unrighteous one. The friends of labor cannot but deplore the backset which must be the inevitable result of this foolish and sinful attempt to overturn the natural laws of supply and demand. The proportion of those who have seized upon this opportunity to show their lawlessness is but a handful when compared to the great body of order loving Americans, who hold country dearer than all else, and millions of whom are ready, as in '76 and '61, to rise in the majesty of truth and right and crush out irresistibly the growing element of anarchy.

INSURANCE men in New York City are indignant because the Broadway Cable Company have built a wreck wagon resembling in many respects the patrol of the insurance department. We were not aware that the insurance people held in fee simple any rights of this kind.

## HOW PORTLAND PADDLED.

The June floods in Oregon generally give some anxiety to the street railway men of Portland and vicinity. This year the anxiety was not fruitless, as the rains descended and the floods came, enough to scare Noah and his ark. The electric lines were the first to feel the inconvenience, but all the low lying districts were more or less incommoded by the high water. The cause of the flood was the tremendous rain in the up country and the consequent rising of the great Columbia river. For about ten days the good people of Portland had to turn to aquatic exercises, nolens volens, and he who possessed a water craft, from a raft to a steam yacht, was in it in several senses of the term.

The water rose to such an extent that the engines were stopped in one electric railway power plant, although no serious damage was done.

## NEW PUBLICATIONS.

LIPPINCOTT'S MAGAZINE for this month has a very entertaining story by Col. King, entitled Capt. Close. It is a story of the South during the reconstruction period.

THE Walker Manufacturing Company has gotten out a neat and complete catalogue of its entire line of electrical car equipments. The Walker apparatus all being new and of very ingenious design, it will be found interesting reading.

WE are in receipt of two bulletins from the engineering department of the University of Wisconsin which will prove of value to engineers. One of them is entitled "Track," and is a lecture given at the University on the history and future of track construction by L. F. Loree,

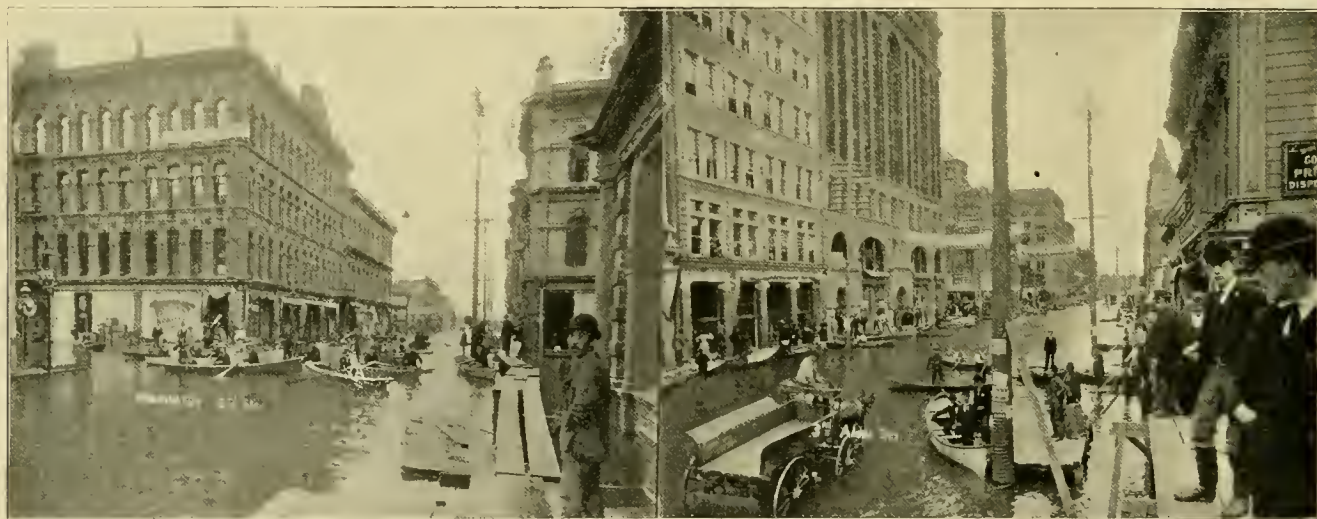

THE GREAT FLOOD IN PORTLAND, OREGON.

The views we present of this interesting occurrence show the corners of Washington and Second streets and Third and Alder streets, both places not far from the river. The improvised gondolas and elevated sidewalks will be noticed, as well as the local Chinese coloring.

The people of Portland are never surprised when the Columbia river rises forty feet in a single night, but the floods of this season are rather more than was bargained for.

A DEPARTURE in tramway traveling has been made in Glasgow, Scotland. The tramways committee of the corporation has decided to institute half-mile stations, marked after dark by a colored lamp, on all the routes, and to charge a halfpenny for each half-mile traversed.

THE Allgemeine Electricitats Gesellschaft of Berlin, two years ago built an electric railway at Kiew, Russia. It proved so successful that three other lines in the same place were electrified, and now Kiew has thirteen kilometers of electric railway.

division superintendent of the Pennsylvania Railroad. The other pamphlet, which is of great value to young dynamo designers, is entitled "Some Practical Hints on Dynamo Design," by Gilbert Wilkes, chief engineer of the Detroit Electrical Works.

THE New York Street Railway Association proceedings for the meeting of September 9, 1893, have just been issued by Secretary Richardson. The report of the executive committee shows that five new companies joined during the year. The consolidation of other companies makes the net increase in membership two, or the total membership twenty-nine.

AMERICAN STREET RAILWAY INVESTMENTS.—Street Railway Journal, New York. Price, \$5. This is the first publication giving in a comprehensive and systematic manner, data regarding the operation and management of street railway properties. The book is put up in attractive shape, and shows an immense amount of labor. Street railway investments have increased so much in importance recently that such a work is amply justified.

## EMERGENCY AND WRECK WAGON SYSTEMS.

A Product of Modern Street Railroading—A System as Perfect as The Fire Department.

It is now about ten years since the Chicago City Railway put in use the first street railway wreck wagon for quick service. Previous to that time, the company of course, owned wreck wagons, but they were not prepared to do quick work in answering emergency calls. When a report came of a wreck, some of the men around the barn would harness up a team of horses and start for the scene of trouble. While the time made by this system would perhaps do credit to a German fire department, it was hardly up



STATION NO. 1 (HORSES OUT).

to the requirements of a large cable road furnishing the daily means of transportation of several hundred thousand Chicago citizens. Delays are long enough without adding the time lost in the barn. The present system, modeled after modern fire departments, was accordingly established. Many other large roads have since taken the matter up so that the City Railway's wreck wagons are not the objects of curiosity to railway men that they once were. However, it is to be expected that as this road had the enterprise to be the first in the field it has since had the enterprise to be among the foremost in making improvements, so that a description of this system will be a description of the best practice, embodying the results of a long experience.

The accompanying map shows the City Railway system and the seven wreck wagon districts into which it is

divided, the districts being indicated by different kinds of lines. All routes not marked otherwise are horse lines. The most important district is of course that including the down town loops which is designated as Number 1. It

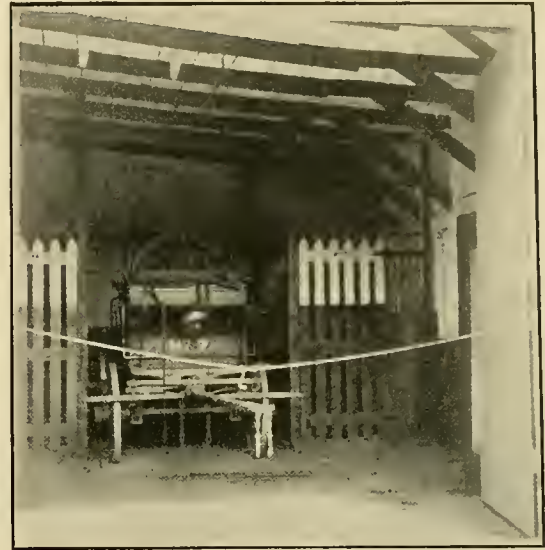

COTTAGE GROVE STATION.

is over three miles long. The wagon is located on Twentieth street near State. At this barn the horses are kept harnessed to the wagon and the weight of the collars is taken by ropes and pulleys as in fire departments.

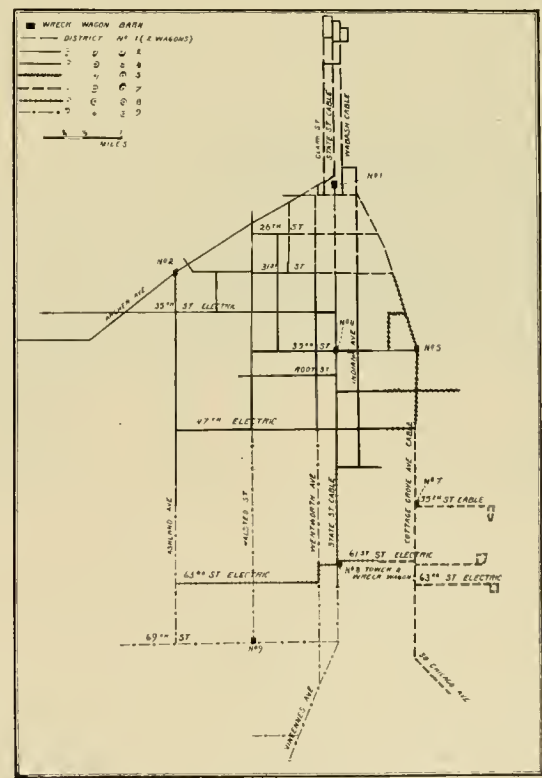

At the other barns they are kept under suspended harnesses and near at hand, as in the less important fire department stations. At Twentieth street two wagons are kept on account of the importance and size of the

district and as soon as the regular wagon is called out a team is hitched up to the second one to be ready to meet any other call that might come.

The tools carried on all of the wagons serving cable line territory are more numerous than those necessary for horse lines. For ordinary breakdowns of wagons on the

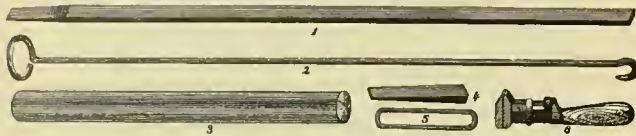

WRECK WAGON OUTFIT.

- 1. Cutting bar.
- 2. Cable hook.
- 3. Roller.
- 4. Wedge.
- 5. Coupling link.
- 6. Monkey wrench.

track or troubles independent of the cable system, the tools carried consist of:

- A skid 3½ by 5 inches.
- A rack and pinion jack.
- A 14 pound sledge.
- A wagon wheel with 4-inch bore.
- Some brake chains.
- A block of wood 6 by 8.
- A monkey wrench.
- Three 12 foot chains.
- Wooden rollers.
- Crowbars and a few coupling links.

The wagon has a rope attached to the middle of the front axle and extending back under the box. In clearing wrecks it is used as a tow rope and saves unhitching the horses from the wagon. For repairs peculiar to the cable system additional tools are needed. These are, a cable hook 5½ feet long, a cutting bar 2 by 1 inches by 5

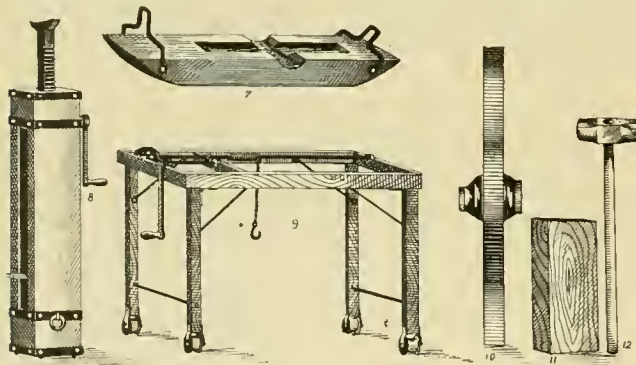

WRECK WAGON OUTFIT.

- 7. Skid.
- 8. Jack.
- 9. Grip hoist.
- 10. Wheel, 4 inch bore.
- 11. Block of wood.
- 12. Fourteen pound sledge.

feet, for cutting grips, punches, wedges for forcing open slots, and a machine for hoisting out grips, made to be set on the edges of the gripman's aisle. For use in case of fire on the cable lines, a set of hose tripods for carrying the hose over the track so that the cars can run underneath, is kept suspended over the wagon so that it can be lowered onto the wagon at any time in case of a call to a fire.

Alarms are given by telephone to the central telephone office of the company at which place is also located a fire alarm tapper. In this way verbal alarms can be given

for the different crews and the men know before starting what to expect.

At Sixty-first and State streets is located the combination tower and wreck wagon which serves all the electric lines and does a regular wrecking service in the small district indicated on the map. However, in case the wrecking work is very heavy, another wagon is called instead.

The regular crew for a wagon consists of two men.



They are run two shifts to a day and do some work at the barns at which they are located.

The time made is fully equal to that made by the fire department. The run down town from Twentieth street to Madison, a distance of nearly two miles, is made almost daily inside of eight minutes. The wagon has answered calls three blocks from the barn in a minute and a half.

THE GLASGOW MUNICIPAL TRAMWAYS.

On July 1 the tramways of Glasgow, comprising 31 miles of double track, were taken out of the hands of the company which leased them since 1870, and are now operated by the city. The lines were originally laid by



the city and have been leased to the tramway company on conditions which provided for the payment of interest

on the investment and the renewal of the track at certain periods. When the city took control, it furnished its own rolling stock and horse flesh throughout, leaving the old equipment on the company's hands. The company has been preparing for the change for some time so that the loss will not be as great as it otherwise would. The company has already an extensive express and 'bus service in the city, and the 'bus service will be still more enlarged so as to seriously compete with the tram lines. It is paying a dividend of five per cent. The city has built its own barns and shops to the number of eleven, and starts out with 250 cars and 3,000 horses. The city

guard the spot where one short year ago the earth and the inhabitants thereof gathered in the White City by the inland ocean.

The fire originated in the terminal station and spread to the Administration building, whose magnificent tower and sculptures, as if unable to bear the sight of destruction, leaped inwardly upon the fiery mass, falling in twelve minutes after igniting. The Mining and Electricity buildings and the Machinery Hall by this time were seething masses of flames, followed by Liberal Arts, and before the material gave out all that was left of the White City were the buildings mentioned. The fire department was



Machinery Hall, Looking East.

Liberal Arts, Looking North (Government Building in Distance).

Liberal Arts, Looking Southeast (Hide and Leather in Distance).

Agricultural Building (Colonade in Background).

will make its own cars and do all its own repair work. Some of the barns were built with a view of changing to mechanical traction soon.

THE LAST GLIMPSE OF THE WORLD'S FAIR.

Just after the general pyrotechnic display of July 4, the World's Fair buildings at Jackson Park, Chicago, took it upon themselves to furnish further excitement. So on July 5, at six o'clock in the evening, the lonely relicts of the greatest of expositions bade a fiery farewell to the scene of their former grandeur, and before the sun rose next morning, only the United States Government, Fine Arts, and Transportation buildings were left to

powerless and could only devote its attention to saving the Art building, now the Field Columbian Museum. While all mourn the loss of these relics, none can feel other than that the end, though awful in its grandeur, was far more fitting and appropriate than the work of vandal wreckers.

A HITCHING-ON ordinance has been passed by the Cleveland, O., city council, with a \$5 fine penalty for its contravention.

SUPERINTENDENT HEINS, of the De Kalb Avenue Electric line, Brooklyn, discovered a motor car on fire in the barn recently. The only explanation is that an incendiary had been at work. A detective was detailed to find out the miscreant.

## PERSONALS.

J. L. McLEAN, of the Denver Tramway Company, Denver, was a recent caller at our New York office.

WILLIAM C. WILCOX, of Utica, N. Y., a prominent street railway and brewery capitalist, died last month, aged 62.

W. S. JEWELL, the general manager of the Toledo Consolidated, called on the REVIEW when in Chicago, recently.

WM. ROSSBOROUGH, formerly superintendent of the Rochester Street Railway, has been made superintendent of the Norfolk, Conn., system.

EUGENE T. WORTHING, superintendent of the Biddeford & Saco Street Railway, was severely injured by being jammed in between a post and a car, in the car barn.

PRESIDENT J. H. RHOMBERG, of the Dubuque Street Railway, says that his company will put in a new ball park, which will be so arranged that it can be turned into a skating rink in winter.

GOVERNOR BROWN, of Maryland, president of the Baltimore Traction Company, has decided to run for a second term. He is prominently mentioned also as a successor for Senator Gorman.

PRESIDENT FLYNN says that the Nassau electric railway of Brooklyn will be opened about the middle of July. An iron bridge over the Ocean Parkway at Church lane is a feature of the undertaking.

ON the retirement of Superintendent Huenerfauth, of the Mansfield, O., street railway, the employes presented to him a Knight of Pythias ring of elegant design. Mr. Huenerfauth responded by inviting the men to a dinner.

PRESIDENT LANNES and the officers of the Carrollton Railway, of New Orleans, have started a series of popular concerts at Audubon Park. The place has been refitted, cleared of under growth and rubbish and furnished with seats.

D. N. McBRIER, the genial vice-president of the Ball Engine Company, of Erie, Pa., is spending a few weeks at the Chicago office, while Western Manager McBrier takes a vacation. Mr. McBrier reports things very lively and inquiries numerous.

FRANK A. MORRELL, the ever popular representative of the Lewis & Fowler Manufacturing Company, Brooklyn, is spending a few days in Chicago, calling on his many friends, of whom few supply men can boast of more than Mr. Morrell.

J. C. BRIDGEMAN, of the Hazard Manufacturing Company, Wilkes-Barre, Pa., made us a call while in Chicago looking after the interests of his company, whose excellent cables are in use, and have been for years, on many of the cable lines in this city.

INSPECTOR RICHARD JOHNSON, who has charge of the Niagara street division of the Buffalo Railway, was decoyed into a room in the power house and presented with a gold watch by the conductors and motormen under him, at the first anniversary of his connection with the road, recently.

SUPERINTENDENT THOMAS A. ROBERTS, of the Augusta, Ga., Electric Railway Company, died June 27, of congestion of the brain. Mr. Roberts was a self-made man and rose from a conductor to his late position. His three and a half years at Augusta were marked by ability and good will from employer and employes. He leaves a young wife. Mr. Roberts came from Kansas City, Mo., where Col. Dyer met him first. Every one who knew him mourns the loss of a gentleman and a business man of worth. He was but 30 years of age.

## MASSACHUSETTS ASSOCIATION.

The Massachusetts Street Railway Association assembled for its monthly meeting, June 28, at Lakeview, Lowell, as the guests of the Lowell & Suburban Street Railway Company. The committee on entertainment was composed of Col. Percy Parker, Manager P. J. Sullivan, August Fells, W. G. Benedict, M. F. Brennan, S. B. Puffer, Ed. Conant, et al. A visit to the power station, dinner at the Lakeview Pavillion, followed by the speeches, were the main exercises, and a box party at the theatre closed the day. The meeting was one of the most widely attended ever called by the association.

The visitors present were:

Col. J. H. Cunningham, Boston, President.	
August Fells, Lowell, Vice-president.	
W. B. Ferguson, Gloucester.	A. P. Smith, New Bedford.
A. B. Bruce, L. L. & H. St. Ry.	C. E. Barnes, Plymouth.
W. T. Kimball, " " "	W. Wentworth, Merrimac.
F. Butler, Lawrence.	F. Woodman, Haverhill.
A. E. Butler, " "	S. Bachman, New York.
G. C. Moore, Taunton.	B. J. Weeks, Quincy.
C. F. Woodward, Wakefield.	J. R. Graham, " "
Mayor Harmon, Lynn.	A. H. Stone, Worcester.
B. F. Spinney, " "	J. N. Akerman " "
D. H. Sweetzer, " "	C. B. Pratt, " "
J. B. Breed, " "	R. S. Brown, Boston.
C. B. Tibbets, " "	C. S. Sergeant, " "
L. Newhall, " "	Gilbert Hodges, " "
E. C. Foster, " "	J. E. Silvester, " "
A. F. Breed, " "	C. S. Clark, " "
J. N. Smith, " "	G. W. Manfield, " "
L. F. Johnson, " "	J. N. Peterson, Salem.
L. G. Hollis, " "	T. H. Johnson, " "
C. D. Pecker, " "	F. H. Monks, Brookline.
F. S. Pevear, " "	W. W. Sergeant, Fitchburg.
D. J. Lord, " "	R. S. Gough, Fall River.
R. E. Harmon, " "	J. F. Siebel, Taunton.
J. F. Shaw, Newburyport.	J. M. Porter, Amesburg.
F. L. Atkinson, " "	G. E. Tripp, L. L. & H. St. Ry.
S. Levey, " "	N. E. Morton, " "
E. P. Shaw, " "	J. R. Simpson, " "
	C. S. Mendall, New Bedford.

THE Sterling Supply & Manufacturing Company, of New York, is putting its fender on the Broadway cars, New York. The fender is simple in construction, strong in material, and efficient in operation.

HE HAD A STRIKE IN THE FAMILY.

The walking delegate never tired of talking of the strike, says the Detroit Free Press. He held that it was justifiable if ever a strike was, and he was prepared to demonstrate that it was perfectly proper to strike to secure any desired result. He so told his wife, and she seemed to agree with him. She said it seemed to be the easiest way of enforcing a demand.

And that night when he came home he found that the table was not set.

"I want a new dress," she said, when he asked what the trouble was.

"I know; you've been bothering me for that dress for a month," he said, "But how about supper?"

"There isn't any," she replied. "This is a strike."

"A strike?"

"Yes, a general tie-up. I've been trying to secure a peaceable settlement of this trouble for some time, but now I mean to enforce my rights."

"Mary, do you dare—?"

"O, don't talk to me that way! If I can't get you to arbitrate, why I've got to strike. I don't care if it does block the wheels of trade."

"But, Mary, you don't understand."

"O, yes, I do. I've made my demands, and they've been refused. I've asked for arbitration with a view to compromise, and that has also been refused. A strike is all that there is left, and I've struck."

"But your demands are unreasonable."

"I don't think they are."

"You're no judge."

"You're the judge of your own demands when you strike, and I'm just as good a judge as you are when I want something. It's no use talking. The strike is on."

She folded her arms in a determined way, and he subsided. It was perhaps half an hour later when he looked up and asked:

"Mary, is the strike still on?"

"It is still on," she replied.

"Aren't you hungry?"

"No. I saw that I had something in the treasury before the strike was ordered."

"Meaning the pantry?" he asked.

"Meaning the pantry," she returned.

"I believe I'll get a bite," he said.

"It's locked," she replied. "The reserve is to be used simply to keep the strike going. You can't touch the striker's resources."

"Be careful, Mary," he said, warningly. "If I shut off the cash——"

She laughed and nodded toward the pantry.

"I can stick it out a week," she returned.

Five or ten minutes later he proposed that they compromise on the basis of \$10.

"Twenty," she replied firmly.

"But that means ruin," he protested. "I can't afford it."

"That's your business," she answered. "I offered to arbitrate once."

It was 10 o'clock that night when he finally gave in, and somehow he felt that he had experienced a new phase of the strike business. It looked different from the other side of the fence.

S. V. PICKENS, OF NORTH CAROLINA.

We have this month the pleasure of presenting to our readers the portrait of S. V. Pickens, the president, vice-president, general manager, secretary and treasurer of the Hendersonville, N. C., Street Railway Company. Mr. Pickens is a North Carolina Prohibitionist and a lawyer of eminence. Mr. Pickens was a visitor at the REVIEW office last summer, and we speak whereof we know when we say that no visitor to Hendersonville's elevated and wholesome climate should miss meeting the genial gentleman or forego a ride on the street railway in the smallest town on earth having a street railway. Mr. Pickens has a franchise for ninety-nine years, which will give Hendersonville a chance to grow and the railway to extend.



S. V. PICKENS.

THOU SHALT NOT SMOKE.

An old ordinance has been resurrected at Indianapolis, Ind., by the zealous city law department. The ordinance provides that: "It shall be unlawful for any man to smoke a cigar, cigarette or pipe in any street car of the city of Indianapolis while the same is carrying passengers, or, waiting on any public street for passengers, in said city. Any person violating the foregoing provision shall be fined in any sum not exceeding \$100, to which may be added imprisonment not exceeding thirty days, on complaint of any citizen before the mayor." President Mason says, however, that smokers may still smoke on the three rear seats of open cars. We suggest now that if any Indianapolis man has an enemy, that he watch for infraction of this rule and haul him to the justice.

THE new purchasers of the Maryland Central Railroad, which is the Maryland end of the Baltimore & Lehigh, say that they intend to use electricity as a motive power to supersede steam. John W. Brown, of Baltimore, was the buyers' agent.

THE Aurora, Ill., street railway has resumed the use of coal, discontinuing oil fuel as too expensive.

## RAILWAY MAIL SERVICE.

Sketch of how the Mails are Handled on Railway Cars.—Possibilities of Mail Carrying by Street Railways Promises to be an Important Feature of the Future. Success of the Scheme in Various Cities.

## PART I.

There is probably no department of that magnificent business achievement of the United States government, known as the postal service, so much discussed and so little understood as the railway mail section.

Figures are delusive affairs, and as inartistic as the skeleton frame of statistics can well be, but nothing else can startle the mind into a realization of the magnitude of this branch of the public weal.

Therefore, we submit to the kind reader's attention the following data:

On June 30, 1893, there were 1,116 railway post office lines in operation, covering 146,666 miles of railway upon which 6,082 postal clerks were employed in the distribution of mail. Besides this, 36 steamboat lines, with 45 clerks assisted in these duties.

The railway postal clerks traveled in crews, 152,979-607, and the steamboat men, 1,752,062 miles. These two classes received, handled and distributed 9,772,075,810 pieces of mail matter in transit! The mind staggers at this array of figures, but the accounts at Washington attest the truth of the statement.

In addition to this immense mass, a mere bagatelle of 446,449,469 pieces were redistributed and prepared for immediate city delivery. It is to assist this latter service that the REVIEW advocates the general adoption of street railway mail service in large cities and upon interurban lines.

Of this immense number only 1,367,880 pieces were distributed "contrary to schedule" and "counted as error

It is an interesting fact that out of the 68,403 post-offices in the United States, the ten largest show aggregate receipts of 30.2 per cent of the total revenue of



EXTERIOR—RAILWAY POST OFFICE.

the department. These ten are: New York, Chicago, Philadelphia, Boston, St. Louis, Cincinnati, Brooklyn, San Francisco, Baltimore and Pittsburg. This shows also the fact of the great preponderance of the service in large cities, the expediting of which is commended by the REVIEW to the magnificent street railway systems of each city named.

The postmaster general, in his last, 1893, report, says: "At this point it is in place for me to call attention to the importance which already attaches to, and which I believe will grow from, the utilization of the electric car lines for mail transportation purposes. These companies can perform much service that would otherwise depend on the star carriers; and as the visible outlay incurred by the road is small, they are disposed to accept ordinary railroad rates for the same. My desire is, that wherever the general service can be advanced, without the duplication of routes unnecessarily, it is in the direction of improvement to make use of rapid transit, street and suburban street car lines."

The system of paying the transportation companies now in vogue is by weight per day.

The railway mail clerk is perhaps the most thoroughly competent employe of the government. He is selected by a thorough civil service examination, and only by a constant study of the duties of his position is he able to retain it.

The examination for admission to the ranks is a severe one, embracing a knowledge of orthography, penmanship, copying, arithmetic, and the geography and railway systems of the United States, especially of the state and railway mail service division in which he is to work. Having passed these examinations, he is admitted on probation for six months at a salary of \$800 per annum. When this period is passed, if he has passed his monthly examinations at a grade of 95 per cent, he receives a position at \$900 a year. If, however, his post is on a car where there is but one clerk and makes more than 80 miles a day, he receives \$1,000.



INTERIOR—RAILWAY POST OFFICE.

against the clerk." Thus for one piece incorrectly sent, 7,144 were correctly thrown. It may be stated in this connection that every piece of mail matter delayed ten minutes is counted as "error" against the clerk so delaying it.



The new clerk, on reporting for duty, finds himself in a car built after the fashion indicated in our engraving (that is, if it is a regular R. P. O. car), with several others of the staff. Two styles of cars are in use—one 60 feet long, for letter mail, and the other 40 feet, for paper mail and storage. On each side of the "paper" car, extending half its length, is a peculiar iron frame in which sacks may be hung, and when not in use, folded up against the wall. Between these iron frames are distributing tables which are movable at will of the clerks. From the tables the mail is assorted into the proper pouches. At each end of the car are stalls for the storage of the pouches after being properly marked.

In the letter car, substantially the same arrangement is found, except that only one end is used for storage, while at the other is the "letter case" and pouch rack. The former consists of numerous pigeon holes which line the walls of this end of the car from the distributing table to the roof. Different sections of these pigeon holes are devoted to the distribution of the letter mail of the various states which the clerks "work," each one being labeled with the name of a town or railway postoffice.

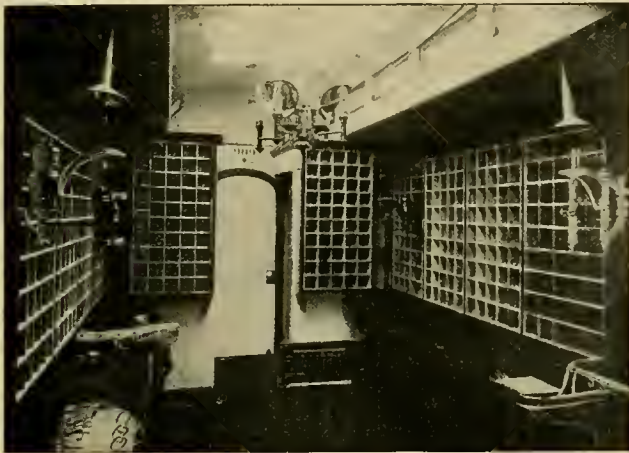

LETTER RACKS—RAILWAY POST OFFICE.

Into these holes the letter mail is distributed, and as fast as they, fill the letters are tied up into packages and thrown into the proper pouch hung on the pouch rack.

From the moment that the first mail wagon lumbers up to the car, the mail clerks are on the jump, dragging in the pouches, arranging them in order and finally distributing the contents as outlined. The pouches are full of letters tied up in neat packages, with slip on each package which shows the destination of the package and the name of the clerk who arranged it, his run and the date.

As soon as the pouches are opened and dumped on the distributing table and "set up," i. e., placed in proper position right side up for the mail clerk, the distribution is made by the clerks. This performance is continued to the end of the run, and the various sacks and pouches en route are disposed of by the same method. Such is life on a regular R. P. O., with variations for a combination car and a "lone man" run.

During his leisure time or lay off, the clerk has something to do besides amuse himself, namely, to prepare for his monthly examination. This latter preparation is made by means of a card system and a "scheme" by which the clerk becomes familiar, not only with his run but with every postoffice and mail receiving point in the state. To remember the route for every small postoffice and cross roads country store where mail is received, is no easy task and the mail clerk's week "off" is as hard a period of work as his regular run.

On examination, a set of cards is given the clerk, and a "case" similar to the one in his car is to be filled correctly. Besides his own state, the surrounding states must also be learned. On one line, for instance, between Indianapolis and St. Louis, the men must know the post-offices of ten states—24,000 postoffices in all. Thus, oh patriot, who would sacrifice yourself in the country's postal service, you may learn the royal road to proficiency.

In the service within city boundaries there is less detail of this kind, but nevertheless a complete knowledge of local stations, routes and methods, is necessary to the intramural mail clerk. The different streets and numbers correspond to the mail receiving points, and post-offices, and every carrier's route should be kept in mind so as to leave as few "pieces" for redistribution as possible. Where regular substations are served, the process will be more analogous to the regular steam system.

The REVIEW has already in the past noted the complete street railway mail systems at St. Louis, Mo., and at Ottawa, Canada, showing photographs of the cars in connection therewith, as well as the pouch systems of other cities.

Later attempts at intramural mail service have like systems, but without special cars.

#### IN NEW YORK CITY

the Manhattan elevated carries pouch mail to and from stations on the different lines. Col. Hain, general manager, says: "We have an agreement with the postal authorities. The mail is carried in pouches on the front platform of the forward car of such trains as suit the convenience of the department, and all matter is in charge of a United States mail agent. We transport each month about 58,000 bags."

#### AT DENVER, COLO.,

the service is performed by ordinary cars. The Denver postoffice makes up locked pouches of mail which are delivered to the train crews of the electric cars to and from the suburbs of Athens, Berkeley, Edgewater, Harman, Lyman, Montclair, South Denver, the University, and between Villa Park and Barnum. The rate of pay is on the same basis as that for regular steam road routes, or at a minimum of \$42.75 per mile per annum for the mileage of each route. This arrangement in Denver not only gives quicker service between the city postoffice and the several offices surrounding reached by the electric cars, but affords opportunity for such frequency in

exchanging mails as the necessity of the patrons of the offices may at any time require.

LINCOLN, NEBRASKA,

has a complete system of intramural mail service as rep-

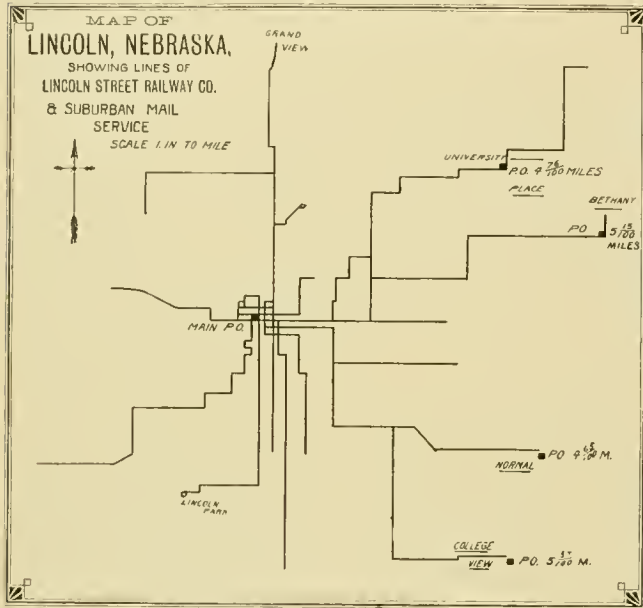

resented on the accompanying map. No mail car is necessary, but the pouches are carried as in the other cases mentioned upon the platform of the cars in care of the train crews. The government here also pays steam road rates, namely, \$42.75 per mile of track per year. Mail is delivered twice each day to all offices except on Sunday. This service has been in use ten months and seems eminently satisfactory to the department, the suburban residents and the street railway company. The street railway has five miles of track in this service which nets it \$213.75 a year without any additional expense or trouble.

TOLEDO, O.,

has a rather more extensive system of street railway mail distribution. The route used is the Robinson system of electric railway. No mail cars are used, but the trainmen take charge of the pouches, which are made up at the postoffice and "tossed off" to the carriers along the line, thus saving them a trip to the postoffice and back. Five points of this distribution are to be made when the system is perfected. The carriers all report for the first distribution at the office, remaining each in his district until evening.

CHICAGO'S

progressive postmaster, Col. Washington Hesing, had not been in office six months before he had begun to devise some method of expediting the tremendous mail service of the second largest postoffice in the country. Having decided that the rapid transit street railway lines were most adapted to the increase in postal efficiency, Col. Hesing called into council General Manager Parsons, of the West Chicago Railroad Company; Manager

Roach, of the North Chicago, and Superintendent Bowen, of the Chicago City Railway. There were also present, J. M. Masten, department agent for contracts for carrying mails, and others from Chicago's post official staff. Three propositions were advanced, viz., mail cars specially built to run on the three different systems, with switches to allow them to go into the postoffice building. The second plan is similar to those outlined above, giving the mail into the care of the transportation companies' employees. The third is to place messengers on the cars to take care of the mail to be consigned to the various sub-stations. For instance, on West Madison street there are to be three stations, namely, the Madison street station, corner of Madison street and Center avenue, the next receiving and discharging station at Western avenue and Madison street, and the last at Crawford avenue, near the limits. The carrier in charge of the mail will start out from the postoffice on a West Madison street car. At Center avenue he will be met by an employe of the sub-station, who will receive the pouch or pouches intended for that locality and give into the charge of the messenger two pouches, one for the Western avenue sub-station and one for Crawford avenue. On reaching Western avenue, the messenger will throw off in the same manner two pouches, namely, the one from the postoffice and the other from the Center avenue station, taking on one for the Crawford sub-station. On the return trip the same process will be gone through, taking Crawford avenue mail for the Western avenue station,

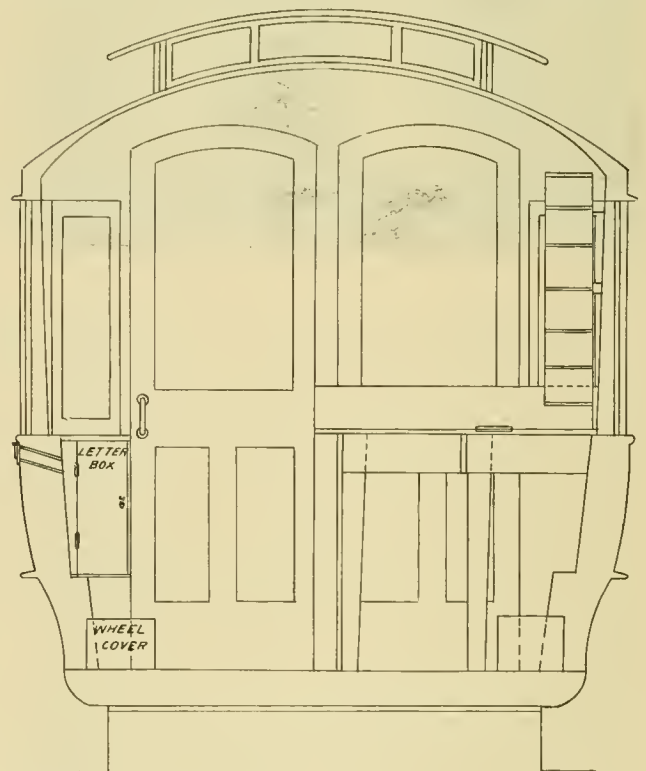

END ELEVATION—BROOKLYN STREET CAR POST OFFICE.

the Center avenue district and the main office. On the North and the South division a similar arrangement will be made and the service made from one and a half to

two hours quicker. With regular postal cars the mail may be sorted en route and for this method the REVIEW unqualifiedly declares.

BROOKLYN, N. Y.,

is to have a complete system of street railway postal facilities, and President Benjamin Norton, of the Atlantic Avenue Railroad Company, writes that his system has closed a contract with the government for carrying mails on the Fifth Avenue line from the main postoffice as far as Thirty-sixth street, the station at which the electric lines to Coney Island and intermediate points terminate. The plan went into effect June 25. A special car is fitted up for the transportation of the mail. One-half of it is arranged exactly like a railway postal car for steam roads and the other half is to be used by the company as a

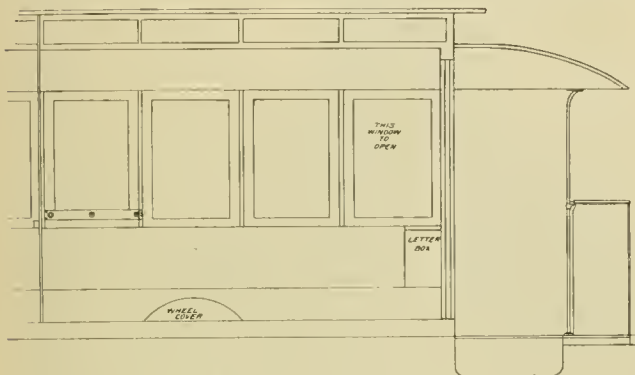

SIDE ELEVATION—BROOKLYN POSTAL CAR.

smoker. The exterior is painted white with gold lettering. It is intended to have several of these cars as necessity demands. Nothing definite has been done as yet in regard to placing letter boxes on the cars.

Mail will be sorted on the cars en route, and a special side track into the main postoffice will facilitate the handling of the mails in and out of the building. All cars on

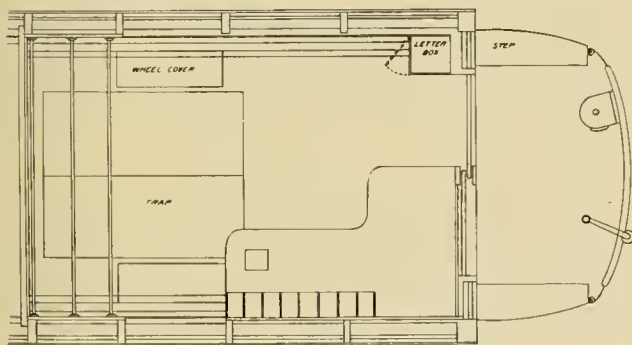

PLAN—BROOKLYN STREET POSTAL CAR.

the Fifth Avenue line will be allowed the privilege of being labeled "U. S. Mail," with the concomitant advantages of government protection in troublous times and an advertisement not to be disregarded.

The Atlantic avenue car, a series of plans of which we represent, is a remodelled Brownell made originally by the Brownell Car Company, St. Louis. It is divided in the center by a partition and one-half is used as a railway postoffice. By reference to the plan view it will be seen

that a letter box for the convenience of passers by is placed on one side at the end, while opposite is a sorting table, above which at one corner is a rubber mat 6 by 6 inches square for stamping purposes. Above the sorting table is a "case" of 48 boxes  $4\frac{1}{2}$  by 5 by 7 inches. These are in six rows of eight boxes each. The board is six inches high that keeps the letters on the table, and a wire net stretches to the wall so that none fall in behind the table or into the window grooves. A combination oil and electric light fixture lights the compartment. At the end of the compartment, next to the partition, is a series of  $\frac{3}{4}$  inch iron pipe, to which the pouches are hung. The sectional view shows the position of the letter box and the relative place of the table and case. The longitudinal section shows the side exterior of the car and the only window which may be opened and shut. Frank Silliman, Jr., was the designer of the car under direction of President Norton and his advisers.

THE St. Augustine Railway & Steamboat Company, of St. Augustine, Fla., will build a line to North Beach from the city. Electricity will probably be used and Charles Sperry is superintendent.

ON the Davenport and Rock Island Railway Company, Secretary J. F. Lardner has instituted a method of numbering his conductors similar to that in use elsewhere, namely, numbers on the cap over the ears, as well as in front. By this means the man's number is visible in three positions.

THE medically-expert daily press has discovered another danger in the trolley, namely, that it causes insanity. As the editorial staffs of these papers are the only victims of trolley insanity, we presume that they ought to know whereof they speak. Trolley insanity is particularly rampant in New York City, although its effects are observable in Philadelphia, where its form is trolley paresis.

SOME foolish employes on the Hammond, Whiting & East Chicago Street Railway went on a strike last month out of sympathy for the Pullman employes. They claimed that the cars on the electric railway had been leased from the Pullman Company. The cars had been bought and paid for, which, having been proved, the men went back to work. Such idiocy makes the public lose respect for organized labor.

THE subway commission of St. Louis has submitted an ordinance for the approval of the council, which demands the removal of all overhead wires in the down town district. Telephone, telegraph, electric light and electric power wires are specified, and the district named is that bounded by the north side of Cass avenue, the south side of Chouteau avenue, the west side of Twenty-second street and east of the Mississippi river. The time given for removal is by July 1, 1896, and the removal is to be at the expense of the companies owning the wires.

### THE VALUE OF AIR BRAKES.

Practical men are apt to think too lightly of the question of improved brakes. There is, of course, a great deal of rot going the rounds of the press as to what a brake should do. A brake would need to perform miracles to reach the newspaper ideal. When the safety of passengers, cars and tracks is considered, it is useless to expect much quicker stops than can be made with a good air brake. However, the real question at issue is as to whether the first cost and maintenance of some modern type of brake is not too high in proportion to the advantages gained. The question of increasing the complications under a car is included in the previous one, as it influences simply the cost of maintenance. It is impossible to figure how many dollars worth of damage claims will be avoided, how much increase in revenue the quicker schedule made possible by the improved brakes will bring, or how much advantage there will be in not being restricted to men of the Hercules type when hiring motormen. We believe that the account will foot up on the air brake side after a few months trial on roads operating electric or cable cars. There is no doubt but that the physical labor involved in working the common brake takes away from the other good qualities of a motorman; there is no doubt but that several seconds are wasted at each application of the crank and chain brake; and there is no doubt but that flat wheels are more common than they would be with air brakes. The air brake is no experiment, and can be applied to trailers with equally good results.

### COMPRESSED AIR AT WESTFIELD.

A car operated by compressed air has been running experimentally at Westfield, Mass., under the direction of J. F. Lewis, of the Rand Drill Company, and our report from that point states that the operation has been carried on without failure of any kind, and that the public are much pleased. On July 4 as high as 75 passengers were carried on the small car, and during the day 1,800 fares were collected. The operation of this car is being watched with much interest, and it is expected that the line will be equipped with this system in the near future.

### MARRIED.

George Nicholas Sargent, of the engineering firm of Almon & Sargent, Boston and New York, and Miss Alice Adelaide Proctor Poor, of Albany, N. Y., were married June 11, at the Cathedral rectory in Boston.

At noon, June 14, George Barton Muldaur, associate editor of the *Electrical Engineer*, and Miss Caroline Southmayd, of New York, were married in Christ Episcopal church, Elizabeth, N. J. The REVIEW extends congratulations to both of the happy couples.

### THE SIMONDS STEAM WAGON.

A steam wagon recently designed and built by C. L. Simonds, of Lynn, Mass., and herewith illustrated, weighs 437 pounds, and is constructed almost entirely of iron and steel. The boiler is of the porcupine type with twenty-eight square feet of heating surface. The engine is vertical, with a link motion, and cranks ninety degrees apart. There are two pumps, one for feeding the boiler with water from a ten gallon tank, and the other for supplying air to the naphtha tank. There are five large burners for burning naphtha. The exhaust steam passes



SIMONDS STEAM WAGON.

through a feed water heater to a perforated coil of pipe in the combustion chamber, destroying the noise and improving the combustion. The usual steam pressure is 100 pounds. The wagon is hung on three elliptic springs and runs ten miles an hour on ordinary roads, carrying two people.

### HELP OUT THE ATLANTA PROGRAM.

Richard McCulloch, engineer of the Cass Avenue & Fair Grounds Railway of St. Louis, was appointed a committee to report at the Atlanta Convention on "Mail, Express and Freight Service For Street Railways." A circular has been sent out by him to all the roads in the United States, requesting information on this point. The attention of companies is called to this, and we hope that there will be a response that will enable a full report.

The assignment of this paper could not have gone into better hands, and the convention is assured a very interesting and valuable paper on a most inviting subject.

SINCE the introduction of electricity the Brussels, Belgium, tramways have largely increased their receipts.

THE CARTER BRAKE.

A LITTLE OF EVERYTHING.

The Carter brake, made by the Carter Car Brake Company, of Minneapolis, belongs to the class in which the motion of the car wheels is made use of to aid in stopping the car, but differs mainly from that, inasmuch as, while most brakes of that kind are provided with the usual brake gear together with a friction clutch on the

JUDGE BAKER recently decided that John C. Shaffer, of Indianapolis, Ind., was entitled to \$25,000 commission for selling the Citizen's Street Railway to the McKee-Verner syndicate.

THE Highgate cable tramway of London is to be sold at bankrupt sale. It has been closed for eighteen months. About \$5,000 worth of repairs are necessary before it can be operated.

A PROPOSITION is advanced by the New Haven, Conn., electric railways to carry freight at night to and from the various factories on the lines between the places of business and the railroad depots and wharves.

AN unfortunate foreigner recently took literally the adjuration of an Indianapolis street car conductor to "look out." When he looked out he bumped his head \$10,000 worth—so he claimed. The court held that the company was in no wise responsible for the stupidity of the passenger, who ought to have known better on general principles.

THE State Supreme Court has decided that the Denver Tramways Company's original franchises, granted in 1885, are in full force and effect. This reverses the decision of the lower court, which invalidated the franchise.

THE Pettingill-Andrews Company, of Boston, is meeting with great success in the sale of commutator bars made by the Billings & Spencer Company. The company also has a large number of overhead line material contracts.

BRIDGEPORT, Conn., has had a varied experience with street railway strikers. A few months ago the horse lines were tied up, and recently the construction men on the electric building struck. The affair was soon settled and work resumed.

THE Cincinnati, O., Railway Company recently passed a resolution thanking Superintendent John Harris for his satisfactory management of the May Musical Festival crowds, which are to Cincinnati the largest and most enthusiastic gatherings of the Queen City.

W. E. BAKER is electrical manager of the Metropolitan Elevated, Chicago, in recognition of his distinguished ability in the management of the Intramural at the World's Fair. Starting without precedent and with the most untried propositions, Mr. Baker's masterly energy brought out the success of the Intramural, and marked an era in the equipment of elevated railways. The success of the Intramural, more than any other factor, has opened the eyes of capitalists to the advantages of transmitted energy for elevated railway work, and it is safe to say that not another steam elevated will be built.

Fig. 1

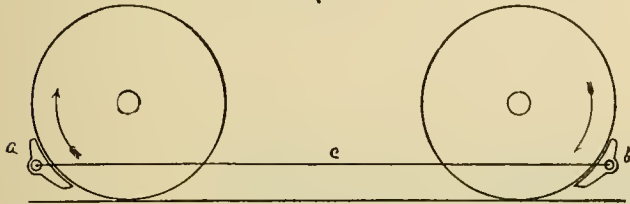

axle, this brake not only simplifies the usual brake gear but is rigged in such a manner as to use the motion of the wheels direct from the shoes so that there is no extra mechanism on the axle. Figure 1 is the inward acting form of brake, and Figure 2 the outward acting. The principle of both is the same. Suppose the wheels, Figure 2, to be moving as indicated by the arrows, and the shoes are lifted so as to come against the wheels. The shoe B will be carried down upon its seat or hanger, and the shoe A will be at the same time carried up until it reaches the limit provided by the tie rod C. If the wheels are traveling in the opposite direction the reverse will be the case. The brakes thus not only apply themselves but equalize themselves. It might appear that as soon as the shoes were brought lightly against the wheels the brake would lock itself and skid the wheels, but such is not the case. The portion of the wheel at the shoe A may be considered as a very obtuse wedge, so that the power with which the brake is applied is proportional to the lifting power applied at

Fig. 2

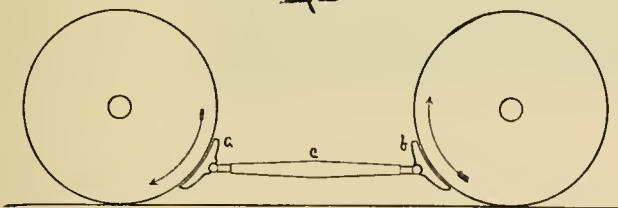

the shoe A. At the same time an immense leverage is exerted. The advantage of this is manifest. The actual leverage required is so small that a hand lever instead of a winding staff is used, saving in the time of application and allowing the motorman to carry out the correct braking principle: that is, to apply the brakes hardest at first. It is much more simple than any equalized lever system brake now in use. No springs are required to release the shoes from the wheels, as they drop of their own weight. C. G. Goodrich, vice-president of the Twin City Rapid Transit Company, says that they have carefully tested the brake; that it has proven very satisfactory, and that they desire to use it on their lines.

CENTRAL PARK, ALLENTOWN, PA.

The accompanying engraving is a reproduction of an enormous but at the same time artistic colored poster sent out from the office of the Allentown & Bethlehem Rapid Transit Company. It is self-explanatory and tells better than words the attractions of Central Park and Manhattan Park.

THE Gleason & Bailey Manufacturing Company, of New York, reports a goodly number of orders for its hurry-up wagons for street railway service.

THE tramways in Havana, Cuba, and the suburbs, which are owned by a company called the Ferro Carril Urbano, comprise a steam tramway from Havana to Vedado, a suburb three miles distant on the seacoast, and three lines of horse trams to Castillo del Principe, Cerro, and Jesus del Monte. The fare is 2½d. or 5d., according to distance. According to the British consul-general, arrangements have been made by an English company for laying down an electric tramway. The projected line is twenty miles long, and its principle object is to connect the principal thoroughfares and wharves with the existing tramlines.



THE following table gives the time required to go two hundred feet at various rates of speed:

10 miles per hour requires	13.6 seconds for 200 ft.
11 " " " "	12.4 " "
12 " " " "	11.4 " "
13 " " " "	10.5 " "
14 " " " "	9.7 " "
15 " " " "	9.1 " "
16 " " " "	8.5 " "
17 " " " "	8.0 " "

THE Electrical World appeared July 7 in a "new dress," the style of type being changed to admit of more matter to a given space. We congratulate our contemporary on its much improved appearance, and give thanks for the greater ease with which it can be read.

THE Robinson lines, of Toledo, Ohio, have begun carrying the United States mail. The carriers make collections as usual, lock their pouches, and send them back to the post office via the street railway, in care of the conductors, who are now sworn mail agents. The mail to be distributed is treated in the same manner to the carriers in each district into which the cars run. No special car is in use.

THE official returns regarding the working of the electric tramway at Marseilles, France, show that it is being greatly appreciated by the inhabitants. During the first two months of this year, the number of passengers carried over the lines—which is about five miles long—amounted to 645,384, as against only 423,267 in the corresponding period of last year.

## ACCIDENT INSURANCE OF STREET RAILWAY COMPANIES.

Since the failure of the American Casualty Insurance Company, which created considerable stir in the street railway world there has been a decided disinclination of other employers' liability insurance companies to enter the street railway field. The American Company made a specialty of this class of risks, and to its sorrow.

The manager of the company, immediately after its fall, refused to be interviewed upon the subject, saying that he was now out of the business, and did not care to give an experience to the public that spoke of the disaster to his company. A prominent under official, who does not care to be quoted, said that the greatest difficulty experienced was the lack of reliable data from which to base the premium. "The insurance companies have absolutely no means of getting at the liability to accidents," said he, "and it would be impossible to judge whether proper precautions are taken, and whether the plant and equipment is in good order. Then, too there is the always uncertain quantity of litigation, the end of which no man can tell, because it is left to a jury which, in spite of the greatest care in selection, is always more or less prejudiced against a wealthy and powerful corporation. Our risks in some cases have been safe enough, but in others have been so costly as to completely cover anything gained from the fortunate ones."

In an interview with the manager of another company of wider scope, but which has taken street railway business as a side line, the gentleman talked very freely upon the subject.

"Our company," he said, "no longer accepts street railway business. We cannot afford to. The street railway company expects to save something by its insurance and we must make something on our risks. In England, where the business was first introduced, it was profitable because of the prevalence of horse-traction and the stringent laws in regard to the overcrowding of vehicles. There the premium may be safely reckoned at 2½ per cent of the gross proceeds of the company. Here with the radical difference in practice, with the almost universal use of mechanical traction and no laws as to the number of passengers to be carried by each car, it is safe to say that 5 per cent is the lowest possible premium at which we can make money. The street railway companies can ordinarily pay their own damages and fight their own cases for this amount and there you are. We can't afford it and they can't afford it. I am sorry to say that we have accepted risks at a less premium and am glad to state that we are out of the business now. A large number of component forces enter into this matter. When we take the risk of paying damages for the possible accidents occurring in any ordinary manufacturing establishment we know about what we are doing. The average manufacturer may expect a serious and costly accident every five years. The ordinary manufacturer, when accidents happen, does not

know what to do. A bond of sympathy exists between himself and the victim of the accident. He has been a long time and faithful servitor, and money considerations set aside, he is really sorry that the man is hurt. He tries to do what is right, but if litigation is entered he has no idea of the procedure. He goes to his lawyer and is charged \$50 to \$100 for advice. If litigation begins he has this expense, and the accident may cost him from \$500 to \$2,500. If the liability is assumed by an insurance company, all this is taken away. The company has the best of legal talent, has an experience that can not be exceeded by any manufacturer, and knows full well the tricks of shyster lawyers and rapacious relatives. It is a claim bureau of universal experience and knowledge. For a manager of a manufactory with a pay roll of \$250,000 a year, the premium amounts to from \$500 to \$1,000 according to dangers attendant. Both sides are satisfied and both gain something from the transaction. Besides this, almost every part of the plant is inspected, elevators and engineers are licensed, and the employes are competent men used to the machinery and processes and regarding each other's lives as interdependent. Boilers, engines, electric equipments and sanitary arrangements are all inspected by city officials and this item of inspection taken from the hands of the insurance companies."

"With a street railway company the conditions are almost diametrically opposed. In the first place, the street railway company has still to maintain its claim bureau if the road is a metropolitan system. The employes are rarely hurt, and constant handling of a million with safety makes them a little careless in the million and first case, and a fatal accident happens. The difficulty of inspection is one that cannot be overlooked. The employe thinks: 'Well, the accident growing out of this weak brake chain doesn't come out of the company's pocket, anyhow, and I'll just risk it. The insurance company pays for it, anyhow, and none of my mates will be hurt at any event.' Then the insurance company has no right to discharge unfaithful help, and the men know it. The insurer can recommend but not execute a discharge. This is a positive handicap, and works to our disadvantage.

"The uncertainty of the jury's verdict is another tremendous item. The public from which the jury is drawn is the natural enemy of the corporation. A man with whom you would trust your last personal dollar seems in no wise conscientious about fleecing a corporation or the government. Public sentiment is infectious, and can enter the walls of a jury room without help, let or hinderance. When a case is called, the company may expect in ninety-nine cases out of a hundred that the damages will be in a handsome amount. This means appeal, and an appeal means more money for litigation.

"Most railway companies count on 5 per cent of gross proceeds as a damage claim fund where the system is a large one. In the English practice 2½ per cent stands in this place. With steam roads, if a large number of systems would enter a pool of their claim departments it

might prove beneficial. I might also suggest a similar arrangement in a city where a number of street railways do business. This is simply a suggestion.

"In small towns, where the crowds are not so great and where the management is in close touch with the employes, the risk is considerably reduced, and in all cases as practice becomes standard the liability is lessened. But nevertheless local conditions are so much at variance, local laws are lax or severe, crowds are great or small, until it is impossible as yet to form any basis other than the 5 per cent mentioned upon which to reckon.

"One point which I am particularly desirous of bringing out is this: The doctrine of Contributory and Comparative Negligence. In many states the latter obtains in the courts and the former in all. An attorney of national reputation, residing in Chicago, says of the doctrine of comparative negligence:

"In all cases of negligence it should be borne in mind that what is known as the rule of comparative negligence" prevails in this state. (Ill.)

"It is a rule which perhaps every lawyer and every judge thinks he understands, but which probably no lawyer and no judge could satisfactorily explain, as the supreme court has held again and again that no plaintiff can recover unless he alleges in his declaration and proves that he was in the exercise of due care and diligence. At the same time the courts sanction such instructions as the following:

"The courts instruct the jury that the plaintiff, before he can recover, must show by the evidence that he was in the exercise of due care and diligence for his safety at and immediately before the time of the accident. But if you find from the evidence that, at or immediately before the time of the accident, the plaintiff was guilty of some slight negligence, but that the defendant was guilty of gross negligence, and that the negligence of the plaintiff, in comparison with the negligence of the defendant, was slight, and that the negligence of the defendant, in comparison with the negligence of the plaintiff, was gross, and the accident was the result of the negligence of the defendant, then your verdict must be in favor of the plaintiff.

"This gives an additional onus for the defendant and enters into the uncertainties of accident litigation and settlement."

PRESQUE ISLE PARK, on the line of the Marquette City & Presque Isle street railway, Marquette, Mich., has opened for the summer. Music and dancing are the principal attractions.

A LANCASTER (Pa.) man has recovered \$18,000 for the loss of an arm in a street railway accident. He sued for \$25,000. This is one of the largest, if not the largest, amounts ever recovered for a single limb.

A DRUNKEN man at Boston recently made three attempts to get run over by electric cars, but the quickness of the motormen in each case saved his life. Another tribute to the "careless and irresponsible" employe.

## THE KING CONDUIT AT WASHINGTON.

A short section of the Bethesda Park branch of the Georgetown & Tenallytown Railway at Washington has been fitted up with a conduit system which is the invention of F. L. King, Hutchins building, Washington, D. C. It is of a very peculiar and novel construction. The conduit, which is only seven inches deep and rests on the ties, is covered by a series of iron trap doors. Under

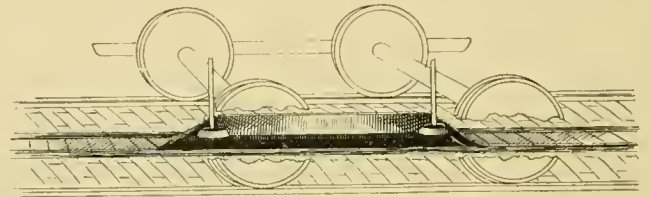

these doors runs a continuous 4-ply leather belt. On the car are two pulleys which lift the cover as the car passes along and allows the trolley to make contact with the uncovered trolley wire. When the car has passed, the cover falls back into place again. The trolley wire is laid on top of a strip of insulating wood and supported on channel irons in the middle of the conduit. The sides

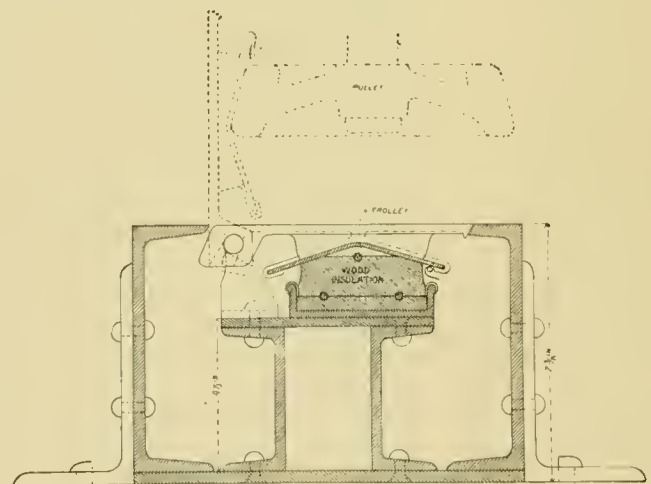

CROSS SECTION.

are left unoccupied so as to receive the dirt that would naturally accumulate around the cover edges. The cover fits down tight over the trolley wire when the conduit is closed. The leather belt of the cover is said to be water proof. The inventor's estimate as to the cost of the conduit is \$12,000 per mile of single track, including sewerage, repair of pavement and all other items. As it rests on top of the ties it can be put on track already laid.

A MILWAUKEE shoemaker in great favor with the "boys" says that the pedal gongs are a great help in his business of half soleing. Some genius ought to devise an iron plate for the right boot for motormen.

THE Salt Lake City Railway Company has built a car remodeling it from an old car. It is larger than the other cars and has a device for turning it into a semi-open car at will by lowering the windows.



OPERATING EXPENSES IN ENGLAND AND AMERICA.

W. B. Thompson, in Engineering, of London, gives some comparative figures as to the relative earning power of horse and steam tramways in England and Electric lines in the United States. He finds that in the United Kingdom the working expenses absorb from 70 to 85 per cent of the gross receipts, while on American electric lines, the percentage is from 50 to 73 per cent. After tabulating the annual reports of the West End Street Railway, of Boston, for six years past, he says of it:

“Attention is especially directed to the decrease in percentage of working costs to gross receipts, which has varied almost directly in proportion to the introduction of electric plant. This reduction has been made notwithstanding the fact that the additional investment required for the introduction of electric plant had to be provided for, and that such part of the company’s former plant as was rendered useless, or disposed of at a loss, had to be written off.”

The tramways of London and Boston are then compared. Boston had a population of 417,720 in 1890 and London 4,306,411 in 1893.

	London.	Boston.
Miles of street operated....	125 5/8	
“ single track .....	250 approx.	268 1/3
Number of cars.....	1080 (a)	2172
Car miles run .....	21,924,290 (b)	18,669,809
Total working expenses....	£885,967	£910,147
“ receipts .....	£1,070,578	£1,338,515
Net receipts .....	£184,611	£428,368
Percentage of expenses to receipts .....	82.7 (c)	68
Total capital invested .....	£3,533,177	£4,435,000
Rate of interest paid on ordinary shares .....	3.32 per cent.	9 per cent

(a) London uses top-seat cars, Boston does not. Boston has to keep a double set of cars; open for summer, closed for winter.

(b) London has the greatest number of car-miles run. The majority of Boston cars are much larger than the London ones.

(c) Boston investment includes £1,500,000 spent during the last five years in re-equipping electrically.

(d) If London’s percentage of expenses to receipts could be reduced from the present 82.7 to 70 per cent., net receipts would be increased to £321,174; if to 60 per cent., net receipts would be £428,231.

It is almost unnecessary to call attention to the fact that the cost of material and labor involved in the re-equipment electrically of a tramway, is much higher in America than in England.”

THE South Ferry cable was laid in the conduit on the Broadway, New York, system recently. It weighed 19,863 pounds and was 5,000 feet long. Ten horses were required. It is a Roebling rope.

THE NEW CAR STARTING SYSTEM OF THE CHICAGO CITY RAILWAY.

The Chicago City Railway has inaugurated a system of car starting on the down town loops of its two cable lines that has so far proved thoroughly reliable and at the same time done away with the wages of two men. Heretofore each cable line had its separate starter. The State street line had a starter at the corner of State and

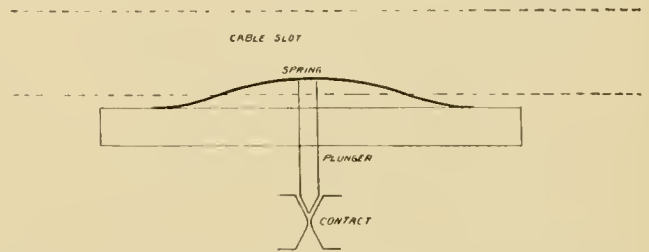

Madison streets, as shown on the map, and the Wabash avenue cars were started from Wabash avenue and Madison street. The starter at the latter post now does the work formerly performed by the two and the State street box has been abandoned. At the corner of State and Madison streets, from which point the State street cars start, is located a bell in the cable conduit. This bell is connected to the starter’s box on Wabash avenue. That the starter may know when a train has arrived at

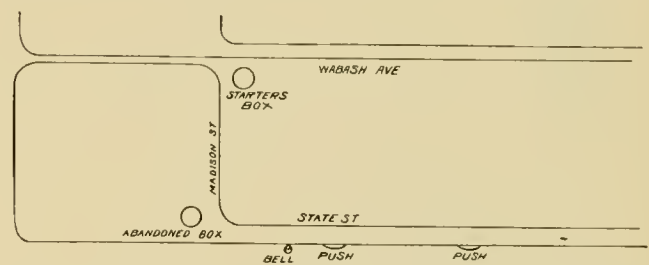

the corner of State and Madison streets, a push button is located in the slot so that it is operated by the grip shank. Farther south on the block is another push that serves the purpose of notifying the starter that the train has departed. The pushes are connected to an annunciator in the starter’s box. The push buttons are placed just under the slot rail. The grip shank strikes a flat spring which operates a plunger making the contact. The connections with the starter’s box are made with lead covered wires run in the cable conduit. The Wabash avenue cars are of course started as before.

THE Guernsey Electric Tramway, England, runs five cars, averaging seventy miles each per day, at a speed of seven miles an hour. Passengers average seven per car mile on week days and thirteen on holidays. The expenses per car mile are 11 + cents total; running expenses, 8 cents. The fare charged is 2 cents, any distance. Parcels are delivered along the route by the conductors for 2 cents. The average traffic is 15,000 passengers a week, not including holiday traffic.

## THE CORNSTALK CLUB DISCUSS THE TROLLEY.

And Decide They Want None of it in Theirs—Why the Electric Interurban is Not Adapted to the Pike Road District.

In a recent issue of a Philadelphia daily there appeared the following item:

### Farmers Discuss the Trolley Question.

At a meeting of the Gloucester County Board of Agriculture, held at Mullica Hill, the question of the trolley on the public roads was discussed, and resulted in the following resolution being adopted:

"Resolved, That it is the opinion of the Gloucester County Board of Agriculture that we do not want the trolley on our public roads, and that we do not approve of the use of public property for private corporations."

Why so important a meeting should have been dismissed with these few paltry lines we cannot understand, for the opinions of the farmers of Gloucester county are entitled to great weight, and are well known to exercise a national influence. The REVIEW, however, was present in the person of its agricultural editor, from whose shorthand notes we condense the following report:

The meeting was called to order by Farmer Turpin, who explained that the president was prevented from being present owing to the sudden illness of his red cow—the one "which was snagged on the barbed wire." Thereupon Mr. Turpin was made chairman, and after protesting he was "no hand at parlymentry," stated the object of the meeting and invited all to "speak your mind and not bein' afear'd of telling what you think on't these trolleys."

No one responded for a while, each being buried in his own meditations, until Sam Hull hitched nervously about in his seat, and after crossing and uncrossing his legs a few times, ventured with "Well now, it 'pears like it was a good thing for to me. You all knows how as its a big ten miles to Woodbury, and that them hills 'fore you get to the crick is powerful hard on a hoss, and you can't load more'n 'bout half noways, and it looks like to me as if them electric cars what can go on one side of the road where they don't do no harm to nobody and what will stop right by a man's field and like as not drive right inside the fence so you can load your truck right there, is bound to be a mighty good thing, and besides, one on 'em will hold more'n a full wagon load anyhow, and we'll have some on 'em fer hay, and some fer corn, and some more fer turnips and sich like, and you kin go to raisin' different kinds of berries and the women folks kin pick 'em and put the boxes right in the car when the men is hayin' and sich like, and when the roads is bad as they allers be in the June rise and the fall rains, it'll be 'mazing handy to git a ride to town even if you ain't got no load to take, and in winter, and in hot weather you don't kill no hosses with the sunstroke, and when the folks is

sudden sick or gets hurted on a mowin' machine and you wants the doctor, or is short of sweetin' for puttin' up presarves and can send a car to town for sugar when its onconvenient to go yourself, and out where I cum from I hear now how they got 'em and has gone to raisin' garden truck and things what they never used to raise before on account not paying to go to town with a armful of pie-plant or a box of radishes, and so believin' in progress for my part I'm satisfied as how it be a good thing, and I'd motion we have it come and the sooner the——"



SAM HULL.

Here Sam paused for breath, and, looking up for the first time, caught the scowl on the chairman's face, which, as he glanced around, was plainly reflected in the others. Sam had come from the west, and had ideas which did not fully accord with the time honored standard of Gloucester county, and, moreover, was allowing the farm which he had come in possession of by the death of his old father-in-law, to run down, which was alone a sufficient fact to warrant his silence when momentous questions were to be considered. Then, too, it was whispered that Sam was not above a pronounced affection for a certain brand of tamarack juice, in quest of which he made frequent pilgrimages to the town. It was on one of these occasions, when returning after a two days' visitation, that one of his horses had succumbed to the heat, and when discovered the next morning was dead by the roadside, while the other was in an almost helpless condition for want of food and water. Sam, however, seemed in no ways the worse for his experience and took the whole matter with a good natured, matter of fact manner, saying, "What's did is did, and there's no use croaking." This had been pronounced a fitting climax, and since then Sam was under a ban. It made no difference to him, however, what people said or thought, and he came to the meetings just as before. What provoked them the most, however, was the fact that his ideas were generally good, even if new to them, and to have this makeshift, from no one knew where out west, presume to suggest to those who had grown up on the farms which had been in the family for several generations, was simply exasperating. Hence, Sam's speech, unmistakably in favor of the proposed electric road which was to connect several towns and villages, was all that was necessary to kindle the flame of opposition and settle the case, so far as that section of the route was concerned.

Sam settled back in his chair, and pulling out a black plug from somewhere in his dilapidated garment, deliberately cut off a generous piece, and after unsuccessfully offering it on the point of his knife with an interrogatory expression of countenance, as slowly placed it in his mouth.

"I hain't so all fired sutin about these trolleys," finally ventured Farmer Barnstall. "I've heard tell on how they was mighty dangus, and how as in one city where they wur, all the wells went dry, and how out west they didn't have no rain, and bimby it got so bad the guv-



THE CHAIRMAN.

ment had to send men up in balloons with lightnin' rods for to git the 'lectricity down outen the air so the clouds could git back again, and then it rained for two days and a night, and there wuz so much water saved up, and it came down so hard, that all the corn was laid flat and even in some places it broke in the barn roofs; and goodness knows we don't want no such foolin' goin' on here."

"Yes," chimed in Neighbor Gordon, encouraged by this arraignment, "my son Octavious, what has bean to college, he sent me a paper from Baltimore with the account in of his lawsuit what he won, and on the very front page it told how as the mayor had made the car folks put a kind of cow catcher on the end of the cars to keep the electricity from jumping out and killing people; and I heard that already how more than 300 folks, especially children, had got killed that way, and they couldn't stop it nor make the car companies quit runnin' the cars, cause they sayed the electricity cars cost 'em a big pile of money, and the law 'lowed 'em to run 'em for ninety-nine years without payin' no taxes. No, sir, I'm agin it."

At this juncture Pete Cook took his turn, and remarked that it would look very bad to have wires hung all along the road, and if they ever wanted to chop a tree and it happened to fall on the wires the tree would get full of lightning, and how was anybody going to remove the tree or chop it up without being killed. Sam Hull's suggestion that there wasn't a tree on Pete's place passed unheeded. Pete also dilated on the fact that if a bird, or maybe a chicken, chanced to roost on that wire it would be instant death, and that eggs had not hatched out very well this season and fowls were going to be high.

This evidently reminded Farmer Skaggs of something he wanted to say, for he broke in with—

"Yes, and jest as like if so be a grasshopper was killed on the wire and fell down in the stubble, and the turkeys came along and eat him, then the pizen would get in the turkey and like as not when the turkeys was eat next Thanksgivin' the folks as eat the turkey would get pizened, and then we couldn't sell no more turkeys, which you all knows is hard enough to raise, and how as copper is pizen, for didn't Bill Smyth's boy swallow a big copper cent and he died."

This overwhelming and impending disaster evidently found great belief, and in triumph, Skaggs looked sideways through the mass of red whiskers which enveloped his entire face.

Farmer Sibley, who sat in the back row and who had been listening very attentively, was now appealed to. When his name was mentioned he started, blushed like a schoolboy, but rose, and grasping the back of the chair next in front, pumped it up and down as if he was shaking down a bag of oats. Sibley was a well-meaning, harmless old fellow, who seldom ever said anything to anybody. It could hardly be said that he was imposing in appearance, for he was short and thick and was extra-

ordinarily bowlegged. Moreover, he had a way of protruding his lower jaw and working it spasmodically, keeping time with a blinking of the eyes, which made a striking combination, to say the least, particularly when observed for the first time. Mr. Sibley had two daughters, long and lank and lean, with colorless blue eyes and fiery red coarse hair, which was neither short nor long, and hung as straight as wire, quite after the fashion of a thatched roof.

Just why old Sibley guarded these unfortunate damsels for whom nature had done so much—such as it was—could not be explained. But he kept a big, cross dog, and took pains to inform the young men that they were not welcome around the place. Inasmuch as the girls were never allowed to go to church or town except when chaperoned by himself or the old lady, and inasmuch further that no young men had shown any inclination to even look at the house as they rode past, this surveillance is unaccountable. True, one day a spruce young fellow from the city had run the gauntlet of the dog, which he kicked with great exactness and vigor, and had poured words of admiration and regard into the famished hearts of the young women. He had also conversed fluently with the old people at much length on the necessity of guarding against the advances of designing young men, and had wound up by displaying a picture of a patent piano which parents everywhere were buying, with which to make home attractive and keep the young people from any desire to look elsewhere for amusement, and had finally secured old Sibley's note for \$300 for one of the afore-said music boxes, which promptly came, with freight charges collect, and out of which the only note which was ever extracted was the one Sibley signed.

General wonder was evident as to what Sibley knew about electric cars, or anything else, but he piped out:

"Mr. Chairman and President, I have listened attentively to all the speeches, and while I don't know anything to the contrary it may all be so. But the most important thing, it seems to me, has been forgot. If this electric railroad is allowed to come they will run cars, and cars don't run themselves. They take conductors. Is there any conductors here? Do you know of any electric conductors living in these parts? Did you ever see one around looking for jobs in harvest? No, I guess not. Who then is these conductors? I'll tell you who they be; they be them city chaps; that's who they'll be. And then what? With their city ways, and blue uniforms, and brass buttons, and a cap, and a badge, and a punch, and like as not shaved twice a week, and wearing posey's in their coats, they'll be making love to all the girls along the line; and more likely than not flirting with them, and throwing kisses as they shoot by. And pretty soon they'll be fetching candy and such things and the fust thing you know they'll be eloping with our daughters, more likely than not with *my* daughters, and then where'l I be?" and overcome by his emotions Sibley dropped exhausted in his seat and wept frantically.



MR. SIBLEY.



SKAGGS.

A painful pause ensued, which was at last broken as all eyes turned toward Squire Crosby. No one presumed to ask the Squire—they knew he would speak when he was ready. The Squire was known to take two papers and one illustrated magazine, and had even been to Philadelphia several times. What his decision would be was awaited with painful anxiety. Bowing to the chair and then to the assembled gathering he spoke in measured, thoughtful tones:

"Mr. President and gentlemen, the occasion which calls us here today is one of great and vital importance. What we do, what the decision of this assembly, will not rest alone with us, it will be more lasting, it will reach out into the unknown future long after we have been laid to rest beneath the sod, and will make our influence felt in generations yet unborn. We must not allow any personal expectation of individual aggrandizement to deviate us one hair's breadth from the straight and narrow and inflexible path of duty. While there may be certain considerations which would seem to make such an undertaking desirable there are others which outweigh them in the scale of calm and unbiased judgment as the solid portion of this terrestrial sphere outweighs the oceans. But to my mind none of you have touched on the greatest evil, the most insidious danger. It may be, occupied as you are with other things and having had no occasion to study the secrets of this wonderful enigma, that you are unaware of the awful consequences which are buried within the dreadful secrets of electricity. You have heard how it has been chosen as the terrible instrument of death in one of the great penal institutions of our land, and how it there works out its fearful consequences and tears the spirit from the unwilling body of its victims. If you permit this road to be constructed you will be in constant peril of just such a death!"

A shudder of horror ran through the group and one or two looked behind them for what, they did not know themselves. Sam Hull alone was unaffected, and straightening out his right leg which was crossed over the other, spat vigorously at the toe of his boot, and smiled to see how near he could come without hitting it.

"Yes, I repeat, just such a death. Ever since electric roads have been permitted, people in the cities where they are, have been dying. At home, in their own beds, with loved ones by their side unable to aid or succor, they have died. And what has been the cause? What will be the cause if such a road is built here? Ah, I will tell you! I will write upon the wall the terrible word, the key with which to unlock the secrets of disaster. It is *electrolysis*! What is that you ask? I do not wonder you tremble at the word, and desire yet, fear to know. But I have studied for us all, that I may raise a word of warning and save you from such a fate. I have done this that you may act in time. It is impossible to confine this terrible agent, electricity. It will leak in spite of all they can do, and so when a car passes along it drops



THE SQUIRE.

unseen into the ground just as wheat or oats fall through the cracks in a wagon box. It soaks into the ground, but unfortunately it does not stay there. It finds its way into the homes of men, it lurks in the gas pipes and water faucets of the house, and spits out sparks of fire when a human hand touches them in the dark. How does it get there? When it soaks into the ground it seeks the water and gas pipes and gets inside of them, and when once in the pipes, of course there is only one way to escape, it must come out of those pipes into the house!"

The death-like stillness lasted but one second, for Sam Hull blurted out—

"Well, you old pumpkin, there haint no gas nor water pipes within ten miles of the Big Pike road, and I haint afeared of no lightning, wet or dry, inside or out!"

The squire did not even look at Sam, and before the assembly had time to reflect, proceeded to read the following resolution:

"RESOLVED, that the citizens of Bigfool township, in mass meeting assembled, hereby denounce the construction of an electric or other railroad as unnecessary and as inimical to the best interests of the public, nor do we approve of the use of the public roads, or any other land, public or private, for any such intent or purpose."

The squire nodded to the chairman who called for a vote on the adoption of the resolution, and as the "ayes" still hung upon the air, pronounced the resolution adopted by a unanimous vote; and it was with great difficulty that Sam Hull, as he rose and gave his trousers a hitch, could be heard in the exercise of that prerogative which belongs to every American as he voted a disgusted—

"No!"

### THE METROPOLITAN L ELECTRIC CONTRACTS.

The contracts for the equipment of the Metropolitan West Side Elevated Railway of Chicago, have been let. Bids were entered for all or portions of the equipment by the following firms: General Electric Company, Schenectady, N. Y.; Westinghouse Electric & Manufacturing Company, Pittsburg, Pa.; Siemens & Halske Electric Company, Chicago; Walker Manufacturing Company, Cleveland, O., and Electric Construction Company, London, England. Owing to the tariff the latter company was entirely unable to compete. After due consideration the entire electrical equipment was let to the General Electric Company at a price, estimated, of from \$200,000 to \$225,000. Those most active in securing the contract for the General Electric Company were Captain Eugene Griffin, W. H. Knight and Theo. P. Bailey, the latter of Chicago.

The contract covers the generators, switch-board, motors, line and construction work. Four generators are called for, two of 1,500 Kilowatts each, to run at 75 r. p. m., and two 800 Kilowatt machines designed for 100 revolutions. The entire capacity of the station will be about 6,000 horse power. The units will be direct coupled.

Three car trains, 55 in all, will be the initial equipment. Each motor car will be equipped with two 100-

horse-power motors and series-parallel controllers will be used. A third rail will transmit the 500 volt current. The General Electric has every reason to be pleased with this, the consummation of the Intramural elevated idea.

#### A BABY AT LESCHI PARK, SEATTLE.

Our readers will remember with pleasure the description of the beautiful Leschi Park resort, at Seattle, Wash., which appeared in our January number. Since then another important attraction has been added, the arrival of which is thus chronicled by the Seattle papers:

"BORN—At high noon, a son, to Tony, wife of the late Jack Sea Lion, of Leschi Park."

Superintendent Haas was somewhat surprised to get a telephone message from the park ordering a physician and nurse for the sea lioness in the tank. Mr. Haas and the attendants immediately went to the place to find the happy mother fondling the new comer as a cat does a kitten. The baby at birth was about eighteen inches long with a little pug dog head and face and fully dressed

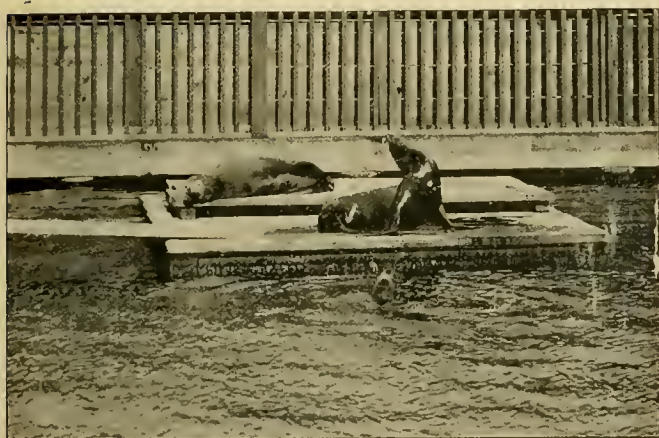

in a steel gray coat. The father of the new arrival died five weeks before the birth of his son and heir. Another sea lioness, Blinkey by name, was greatly exercised over the event and it required all Mrs. Tony's exertions to keep her away from the infant. Superintendent Haas caused a platform to be floated into the pond as a nursery until the youngster shall have been taught to swim and dive and to acquire other nautical accomplishments. The California sea lion (*Zalophus Californianus*) is about half the size of the Arctic sea lion and is thought to have been unable to breed in fresh water. This idea is now thoroughly exploded.

A PARTY of 275 employes of the Pennsylvania Iron Works, of Philadelphia, recently took a trip on the Third avenue cable, New York City, in company with their families. A special train and a supper tendered by General Manager Grist were features of the occasion. All the men had been employed in the construction of the cable road.

#### TRAMWAYS IN THE UNITED KINGDOM.

That excellent English authority, Engineering, under the above title, reviews the absorption of street railway properties by the municipalities, as follows:

"The growing tendency toward what is regarded as municipal socialism, is probably most manifest in the desire on the part of public authorities to absorb tramway systems inaugurated, and in many cases brought to success, by private companies, and no excuse need therefore be made for some investigation into the extent and financial results of the tramways throughout the kingdom. Of the 960 miles of tramway, only 274 are now the property of local authorities, and in nearly all cases the lines are worked by lessees. This leaves 686 miles belonging to private companies. As a rule, corporation owned lines are of greater extent, or, in other words, public authorities have only started the systems where the requirements were great, and the prospects correspondingly satisfactory. The capital expenditures on these tramways is just over 14 millions sterling, or nearly £15,000 per mile; but this includes not only equipments but buildings. It is noteworthy that while in the case of local authorities the cost, including expenditure on buildings and equipments, was only £11,350, in the case of private companies it works out to just over £16,000. It seems difficult to explain this entirely by assuming that a company necessarily requires greater floating capital than a corporation. The idea suggests itself, that while in the case of local authority lines, the paving, etc., is not charged to the tramways, corresponding work is exacted from private companies, to the advantage of the community, and must be charged to first cost of the tramways. Of course, it is possible that part of the difference is due to greater economy, but this can account for only a small, if indeed for any, part of the excess. In England and Wales where there are 761 miles, the capital paid up is equal to £14,650 per mile; in Scotland, where there are 86 miles, it is £15,000 per mile; and in Ireland, with 113 miles, the difference is most marked, as the capital paid up is only equal to £11,200 per mile. Before departing from the capital account, it may be mentioned that there has been little addition for several years, which seems to indicate that under present conditions extensions are not numerous. On ten years, however, there has been a great advance; the capital expended has increased from 8¼ millions to just over 14 millions.

"The traffic has quite justified this advance, for in the ten years the number of passengers has more than doubled, being now 598¼ millions, and, as the number of cars is 4,098, it appears that each car takes 149,800 passengers for the year, or 428 per day, assuming that each works 350 days in the year. The return for the past year shows the receipts for the carriage of these 598¼ million passengers were £3,606,095, or, on the average, nearly 1½d. per passenger. Working expenses absorbed nearly 80 per cent. of the receipts—much more than on railways—or £2,837,446, so that the net receipts were little more than a fifth of the gross receipts. The total net receipts were £768,649, which affords about 5½ per cent on the paid up capital, without making any allowance for depreciation of ways, plant and stock. As to whether municipalities will attain a more satisfactory result it is somewhat difficult to positively determine.

"For several reasons the experience on the Birmingham tramways is most important. In that city, municipal government has more nearly attained the ideal than any other,

except, perhaps, in Glasgow, which stands on as high a plane. Moreover, all systems of traction are adopted—steam, horse, cable and electric—and there are about twenty-five miles open for traffic. In this case the working expenses absorb 75 per cent. of the receipts, so that the results are by no means superior in this respect to the average, and perhaps, are in excess of those in other cities where the tramways are worked by private companies. The income is £154,684, or, £6,187 per mile of tramway. In Glasgow, on the other hand, the receipts are £8,700 per mile, but the ratio of expenses to receipts is over 80 per cent. The expenditure at Birmingham totals £116,969, and the net receipts £37,715, which is equal to £1,508 per mile, so that the return must be regarded as satisfactory, because the capital expenditure probably did not exceed £16,000 to £18,000 per mile. On this point the Board of Trade return does not enable reliable data to be given. A point of interest which may incidentally be referred to is that the cable tramway at Birmingham seems to require barely 50 per cent. of the receipts for the ordinary working expenses, while the electric (storage battery system—Editor) practically absorbs all the receipts: the steam tramway requires about 70 per cent and the horse considerably more. Certainly, private companies have worked the tramway system, generally speaking, most satisfactorily; and it is well that corporations should carefully weigh all considerations before entering upon enterprises simply because they conform to present ideas as to municipal socialism.”

In considering the above it must also be remembered that in those cities where the municipality is operating the lines, it is doing so from choice, having availed of an expiration clause in company's charters. We have yet to learn of any but paying roads being so absorbed and with everything in perfect repair and all the details worked out it is no wonder or special credit if a good showing is made. Then too, municipal officers retain their positions only so long as they can show satisfactory records, and it is to be expected that in the effort to accomplish this, every possible advantage will be taken to make many items of expense, such as paving, etc., formerly borne by the company, as small as possible, by charging them to other departments of the city's accounts. The taxpayer foots the bill nevertheless, forgetting that a possible reduction in fares is at his own expense in another form. Then again, the city may not require of itself expenditures which it does not hesitate to inflict upon private corporations. Any showing, however good, of municipal management of street railways for one or two years, is by no means conclusive proof that any saving is being made the public, even though the figures are made to say so.

ON Sunday, June 24, C. E. Healy, of Detroit, the well-known inventor of the Healy motor, together with two young ladies, daughters of the chief of the Detroit fire department, were drowned. Mr. Healy's two daughters, who were also in the party, were rescued. The party was sailing in a steam launch on Lake St. Clair, when a sudden squall capsized the craft with the above unfortunate result. Mr. Healy's kind disposition has made many friends, who will be shocked to hear of this sad ending of a useful career.

### SHORT CIRCUITED AFFECTION.

He was a hustler, says the Detroit Free Press. On a Brush street car the other evening was a young colored man and his girl, and they not only held each other's hand as they rode, but the young man slipped his arm about her waist and didn't seem to care a copper for the winks and smiles of the other passengers. After a time a white man got up and passed out on the platform and beckoned the young man to come out. The latter hesitated to leave a good thing, even for a minute, but finally did so, and was asked:

“Young man, do you love that girl?”

“Yes, sah, I does,” he promptly replied.

“And she loves you?”

“She do, sah.”

“How long have you known her?”

“'Bout an hour.”

“Isn't that falling in love pretty rapidly?”

“Yes, sah, but dat's de way I does. Doan take me ober ten minutes to fall in love with anybody. We hain't like white folks 'bout dat.”

“How long does it take you to fall out again?”

The young man looked into the car and saw that another colored man who had been standing by the front door had taken his seat. Not only that, but he was holding the girl's hand in his and their heads were bumping together in the most affectionate manner. He took this in at a glance.

“How long, sah? How long? Why, just 'bout ten seconds, sah, an' de ten seconds hev expired.”

And he dropped off the car and went off in the darkness whistling a tune without a quaver of sadness in it.

### OTTAWA'S OPERATIONS.

Ottawa, Canada, is justly proud of its fine system of street railways, which was one of the first in the Dominion and one of the foremost in improvement. In 1866 the first street railway was talked of in Ottawa, and two years later the first car was run, with a completion of the road in 1870. Sleigh service was used in the winter and the comfortless horse cars made their weary way with more or less success until 1892 when the first electric was run. For twelve years of horse car service not a dividend was paid. In 1881 Messrs. Ahearn and Soper acquired the road, electrifying it ten years later. The first year's record of the trolley was 1,520,000 passengers, the next year showed 2,400,000 fares registered, and from that time since, the growth has been even more marked, until for the year ending May 31, '94, the number carried was 2,700,000. The company runs sixty-five cars including three postal cars and has available 1,700-horse-power to operate them, and employs 200 men on an average. The president of the company is J. W. McRae, and T. Ahern general manager; the secretary is J. D. Fraser and the superintendent, J. E. Hutchinson.

STREET RAILWAY LAW.

EDITED BY FRANK HUMBOLDT CLARK, ATTORNEY AT LAW, CHICAGO.

*Damages for Cutting Trolley Wires.*

Where a street railway company authorized by a city to change its motive power to electricity, strung trolley wires across the defendant's railway track at a height of nearly 20 feet, offering to have them raised to the height of 22½ feet, which was the standard height for bridges above the railroads of the state; the defendant company was liable for all damages resulting from its act in cutting away the wires above its track, although it had notified the plaintiff that it would not allow the wires to be strung at a less height than 24 feet, which was the height fixed by the railroad commissioner.

The Michigan Central Railroad Company operates its road across Genesee and Washington streets, in the city of Saginaw, upon the track of the Detroit & Bay City Railroad Company, which latter company has had the right of way across the streets by grant from the city of East Saginaw, since the year 1878. The Saginaw Union Street Railway, then operating its road by horse power, in December, 1889, changed its operating power to electricity, by permission of the city, granted by ordinance. It saw fit to use the trolley system; it placed the trolley wires across the defendant's tracks on Genesee and Washington streets. At Genesee street the overhead wire was placed 19 feet 9½ inches above the defendant's track-rails; at Washington street, 19 feet 6 inches above such rails. On the 16th day of May, 1890, while the plaintiff was in the full operation of its road, and running its street cars, the defendant company cut the wires of plaintiff where they crossed its tracks on Genesee and Washington streets. For this act the plaintiff brought this suit in trespass and recovered a verdict and judgment for \$933.03.

The defense to this action was, in substance, that in operating the defendant company's road it was necessary to pass under these wires cars from 12 to 14 feet and 3 inches in height from the tracks and cars loaded with lumber to the height of 15 feet; that it was necessary to have brakemen standing on the top of these cars to signal the engineer, and for other purposes, and that, under these necessities, the wires of plaintiff were not placed at sufficient height from the ground so that defendant railway could be operated in the usual manner with safety to its employes. That February 11, 1890, John T. Rich, then state railway commissioner, issued an order to the general managers and superintendents of Michigan railroads, instructing them not to permit the erection or maintenance of the wires of electric street railways at a less distance above their tracks than is allowed for bridges and other obstructions not suitably guarded, and that this distance should not be less than 24 feet above the track. April 12, 1890, W. A. Vaughan, division superintendent of the defendant, notified the plaintiff by letter that its wires were less than 24 feet above defendant's tracks and of the railroad commissioner's order, and asked plaintiff company to comply with such order. April 15, 1890, the president of plaintiff company replied to this letter, that it was its intention to have its wires 22 feet 6 inches above the track at steam railway crossings, being

advised that such height was sufficient and was the standard for railway bridges. This letter Mr. Ledyard, president of the defendant company, answered by letter of May 3, 1890, stating that such company would not permit the wires of plaintiff to be strung across its tracks at the height of 22 feet 6 inches, and further wrote: "I am constrained to advise you that if by May 15, 1890, the wires of your company, wherever they may cross the right of way of this company or any of its leased lines, are not placed at the height of 24 feet, this company will proceed to remove the same from its right of way." Nothing further being done by the plaintiff's company, the defendant cut the wires of plaintiff at these two street crossings about 4 o'clock p. m., May 16, 1890.

We are satisfied that the evidence shows that there was ample time while the motive power of the plaintiff was at rest, and when its cars were not running, to have removed these wires; the removal of them was done at a time when it involved great loss to plaintiff and great danger to human life. Under the circumstances, the defendant company was a trespasser ab initio and liable for all damages. It was shown that no bridge on the defendant's company's line was higher than 22 feet, and that the railroad commissioner had sanctioned and consented to the wires of other street railroad companies at West Bay City and Lansing being maintained at a height of 22 feet 6 inches. The defendant company refused to permit the plaintiff to string its wires at this height. The commissioner of railroads had no arbitrary power to fix 24 feet as the height at which such wires must be maintained in the absence of any showing that a less height was insufficient to prevent any danger to the employes of the railroads. The refusal of the defendant company to permit plaintiff's wires to be raised to 22 feet 6 inches—and the testimony shows they could have been so raised without cutting the wires or destroying the property—and its choosing of the time to cut such wires when the plaintiff company was in full operation of its sixteen miles of road in the city of Saginaw was such a violation of the plaintiff's rights as cannot be excused, and justifies the recovery of all damages suffered by the plaintiff on account thereof.

(Supreme Court of Michigan. Saginaw Union St. R. Co. vs. Michigan Central R. Co. 91 Michigan 657.)

*Street Railway Extension—Strict Construction of Charter.*

A statute authorizing a street railway company to extend its lines to portions of certain streets lying "between" Montgomery street and Germantown Road does not allow an extension along the Germantown Road, when construed in accordance with the principle that, in construing grants of powers to corporations, whatever is not given in clear and express terms or by necessary implication, is conclusively considered to have been withheld.

When a charter granted to a street railway company requires the consent of the city council for any extension of the railway lines and a supplement authorizes the extension of the road without consent, a second supplement which is silent as to consent is to be taken subject to the requirement of the charter that consent shall be obtained.

(Supreme Court of Pennsylvania. *City of Philadelphia vs. Citizens Passenger R. Co.* 151 Pennsylvania State Reports, 128.)

*Personal Injury—Right to Presume that Company has Complied with Law—Contributory Negligence.*

In an action against a street railway company for death at a crossing, it was error to instruct the jury that the deceased had a right to presume that the defendant had complied with the law as to providing bells for its teams, in the absence of knowledge to the contrary, and that the failure to have bells on the team hauling the car, was negligence, and if the failure to provide the bells was the direct cause of the injury they must find for plaintiff, where it appeared that the accident happened in the daytime, that the street was clear from obstructions, that the team was moving at a walk, in full view of the deceased, who was well acquainted with the street and in full possession of his senses; because the instructions took from the jury the question whether, if the boy had exercised due care, he might have discovered the absence of the bells, and because the presumption that the defendant would obey the laws and attach the bells must cease if actual knowledge to the contrary were shown.

In such a case the defendant has the right to rely upon the exercise of ordinary prudence on the part of the plaintiff, as in this case, on the part of the deceased, and the plaintiff has the right to presume due care on the part of the defendant; the obligation being mutual and correlative.

(Supreme Court of Missouri. *Lynch vs. Metropolitan Street R. Co.*, 56 American & English R. R. Cases, 571.)  
*Electric Car—Frightening Horse—Care Required of Motorman.*

Plaintiff was riding in a buggy with his daughter along Beach street, Lynn, when his horse became frightened at the sound of the motor and continued sounding of the gong of an electric car, and ran away, throwing him and his daughter from the carriage. The evidence tended to show that the electric car was 100 feet away when the animal first took fright, and that the motorman continued to sound his gong. The defendant contended that it was not negligence on his part to sound the gong, but rather a duty which it owed to pedestrians and other travelers on the streets.

It is a well-known fact that most horses are frightened at their first view of a moving electric car, especially if they encounter it in a quiet place, away from the distracting noises of a busy street. It is only by careful training and frequent repetition of the experience that they acquire courage to meet and pass a car on a narrow street without excitement. The rights of the driver of a

horse and manager of an electric car, under such circumstances, are equal. Each may use the street, and each must use it with a reasonable regard for the safety and convenience of the other. The motorman is supposed to know that his car is likely to frighten horses that are not accustomed to the sight of such vehicles, while most horses are easily taught after a while to pass without fear. It is his duty, if he sees a horse in the street before him, that is greatly frightened at the car, so as to endanger his driver or other persons in the street, to do what he can, reasonably, in the management of his car, to diminish the fright of the horse; and it is also his duty in running the car to look out and see whether by frightening horses, or otherwise, he is putting in peril other persons lawfully using the street, on foot or with teams. Of course, the owners and drivers of horses are required at the same time to use care in proportion to the danger to which they are exposed.

The verdict of \$2,000.00 for the plaintiff is sustained.

(Supreme Court of Massachusetts. *Ellis vs. Lynn & Boston Railroad Company.* 2 American Lawyer, 235.)

[NOTE.—*Greeley vs. Federal St. R. Co.*, 25 Atl. Rep. 796, 4 STREET RAILWAY REVIEW 225, was a case of collision with a horse which had become frightened while traveling through a cut in a street. The court said: "There was evidence that the car was going through this cut at a high rate of speed for an electric car—faster than usual. If this be so, and the jury have so found, it was gross negligence on the part of the company. The cars should have been run slowly and with great care through a place of this description. The cut in the street, and dirt piled upon each side of the track, was a work of its own creation and for which it was responsible."

In *Muncie St. R. Co. v. Maynard*, 32 N. E. Rep. 343, 1 STREET RAILWAY REVIEW 225, plaintiff's team became frightened and backed the carriage upon the track in front of a street railway train. It appeared that the engineer could readily have stopped in time to avoid the collision, but failed to do so. The company was held liable.

In *Lincoln Rapid Transit Co. v. Nichols*, 55 N. W. Rep. 872, 3 STREET RAILWAY REVIEW 702, which is a suit for damages caused by a horse becoming frightened by a street railway car operated by steam, the court suggests that the use of steam engines in operating street cars on a crowded city street is negligence of itself, even though the use of such motive power may have been authorized by the charter of the company.—ED.]

## CEMENT FOR STEAM PIPES.

What is said to be a useful cement for steam pipes in filling up small leaks, such as a blowhole in a casting, without the necessity of removing the injured piece, has been compounded. The cement in question is composed of 5 pounds of Paris white, 5 pounds yellow ochre, 10 pounds litharge, 1 pound red lead, and 4 pounds black oxide manganese, these various materials being mixed with great thoroughness, a small quantity of asbestos and boiled oil being afterwards added. The composition as thus prepared, will set hard in from 2 to 5 hours, and possess the advantage of not being subject to expansion and contraction to such an extent as to cause leakage afterwards, and its efficiency in places difficult of access is of special importance.

THE Washington, D. C., offices of the General Electric Company were transferred to 227 East German street, Baltimore, Md., on June 21.



### MINNESOTA VESTIBULE LAW VALID.

The vestibule laws passed by the granger legislatures of a few states have not generally met with very tender mercy at the hands of the courts. That it is a piece of "class legislation" seems to be the general opinion.

The Supreme Court of the State of Minnesota, however, has declared constitutional the law compelling the use of the "vestibule" for the protection of motormen during the winter months. The test case was that of Superintendent Hoskins, of St. Paul, who was arrested for failing to comply with the requirements of this ordinance.

The Twin City Rapid Transit Company carried the case to the Supreme Court with the result indicated.



The law was sustained at all points. The court holds that when running at a speed of eight or ten miles an hour, with the mercury below zero, the motorman's position is not only one of discomfort, but of actual danger to health and sometimes to life, not only to himself, but indirectly to the passengers in his charge. The corporation held in its plea that the measure was class legislation and not an exercise of the police powers of the state.

One of the vestibules which was built last winter by the Twin City Company, is represented in the accompanying engraving.

### NEGLIGENCE OF A CO-EMPLOYEE.

Suit was begun not long ago against the Metropolitan Street Railway Company, of Kansas City, Mo., by Henry D. Ely, an employe, who sued for damages, alleging as the cause of his injury the negligence of a fellow workman. The plaintiff sought to hold the company liable under Section 1, Chapter 93, of the Laws of 1874, which section provides that: "Every railroad company organized or doing business in this state, Missouri, shall be liable for all damages to any employe of such company in consequence of any negligence of its agents, or by any mismanagement of its engineers or other employes to any person sustaining such damage."

The defendant contended that cable street railway on which the accident to Ely occurred was not a railroad company within the meaning of the act, and upon a demurrer to the plaintiff's evidence, the judge so decided. No written opinion was handed down, the court adopting the view that a street railway was not a railroad unless there was something in the legislative act indicating an intention to include it therein, a doctrine recognized in the following cases: *Thomas, etc., Company, v. Simon*, 20 Or. 60; *Front Street Cable Railway v. Johnson* (Wash.), 25 Pac. Rep. 1084; appeal *Montgomery 20*, Atlantic Rep., 399; *Money penny v. Sixth Avenue Railway Company*, 4 Abbott Pr. (N. S.—367); *Lax v. Forty-second Street Railway Company*, 46 N. Y. Super. 448; *Louisville, etc., Railway Company v. Louisville City Railway Company*, 2 Duval 175; *Cream City Railway Company v. Chicago, etc., Railway Company*, 63 Wis. 93.

*Pratt, Ferry & Hagerman, of Kansas City, Mo.*, were attorneys for the defendant, to whom we are indebted for the above data.

### WILL MAKE LOCOMOTIVES SNORT.

The *Railway Age*, a standard authority on steam railroading, thus comments on electricity as selected for elevated work in Chicago.

"The engineer who is installing the electric power plant for the new Metropolitan Elevated Railway in Chicago, figures that the use of electricity will save that company \$300,000 a year in operating expenses, compared with the cost of running trains by anthracite-burning locomotives. The saving in fuel alone by using soft coal in stationary boilers instead of hard coal in locomotives is figured at \$200,000, and the difference in salaries, if high-priced engineers had to be employed for each train, with other economies which electric power will give, are expected to amount to at least \$100,000 a year more. If experience demonstrates the correctness of these estimates, the steam locomotive will have received another serious setback.

### HOW IT WILL BE A. D. 2,000.

The *Chicago Record's* prophet was seized with a vision, and the vision was as follows:

"A few persons riding in a West Madison street car, last night, witnessed an amusing episode. The car was full, and a stylish young gentleman who entered was preparing to stand during the rest of the trip, when two handsome dressed ladies arose and politely offered him their seats. He took one with a bow of thanks. Soon after, another man, clad in cheap attire, and rather plain features, entered, but the young lady whose seat the first gentleman had not accepted kept her eyes fastened on her newspaper and affected not to see him. The poor fellow would doubtless have had to stand all the way had not the stylish young gentleman arisen with flashing eyes and given up his own seat. The handsome lady evidently felt the rebuke, for she got out at the next crossing, while a suppressed titter ran through the car."

## MILWAUKEE'S NEW TRANSFER.

The new transfer tickets placed on the Milwaukee street railway lines by General Manager Wyman are to be used both by conductors and transfer agents, the black border denoting the one and the colored border the other. The aim has been simplicity and distinctness, to avoid mistake on the part of both conductor and passenger. The acceptor of the ticket has his attention strongly called to the fact that he is on a time limit. In the use

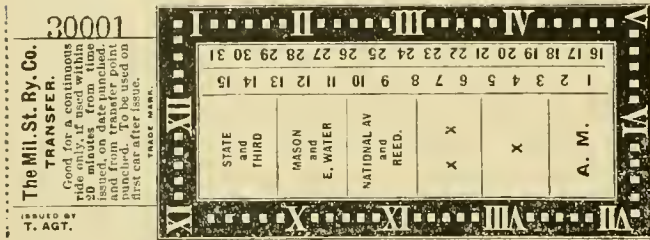

of a. m. and p. m., for p. m. the letter a is simply punched out. The day of the month reference is left out and the tickets numbered consecutively, which is regarded as a check on the matter of monthly issue. The rules referring to transfer have no adjacent reading matter, so that the passenger can not make a mistake as to his obligations. Rand, McNally & Company, of Chicago, were the printers of the ticket and collaborated with Mr. Wyman in the matter.

## BLOCKING CARS WITH PROCESSIONS.

Three months ago a Milwaukee alderman in casting about for some excuse to poise as a friend of the dear people, presented an ordinance, preventing street cars and other vehicles from breaking through processions. Nobody paid any attention to it and the act slid through. The other day a prominent man died and an immense funeral procession was the result. Another result was the complete blocking of all street cars in the heart of the city for three hours, during which time the outside lines also suffered, until the magnificent system of the Milwaukee road was paralyzed. As usual in such cases, appointments could not be kept, travelers missed their trains and officials and patrons were alike in a state of mental and physical distress. The chief of police even refused to allow the cars to slowly move alongside the procession. To make matters worse, several thousand people were making frantic endeavors during the tie-up to get to a circus in the outskirts of the city. President Payne in commenting on the occurrence said:

"The ordinance has been a bad thing for the public as well as the street cars, and it is to the interest of the business community to see that it is repealed. The case to-day was such a flagrant one, that people have realized the true state of things. Why, the entire traffic was stopped on Broadway, Wisconsin street and Grand avenue up to Ninth street, and this route was such, as to stop cars on important streets that intersected. If the police had allowed us to run cars alongside the procession it would not have been so bad, but this they have never allowed us to do. Business men freely

denounced the ordinance, and I saw two traveling men who had missed their train because of the stopping of the cars. They could not understand how the business of a city so large as this could be stopped by a funeral procession, no matter how much honored the man."

There can be no question as to the injustice of the ordinance which should at least be amended so as to limit the time in which cars can be delayed to fifteen minutes at the most. With electric traction, a halt in the procession for only one or two minutes would enable the men to get all the accumulated cars across the line of march even on such routes as run on very short headway. Proper respect to the dead is all right, but there is a certain amount of respect due the living also, and such delays can never occur without jeopardizing not alone business interests, but often the lives of persons who are ill or injured.

Unless the ordinance is speedily corrected, General Manager Wyman says he shall instruct his men in cases of prolonged delay, to disregard the ordinance and then he will protect his men and appeal the case to the supreme court, where we confidently believe it would be declared unconstitutional.

## HOW IS THIS FOR A KICK?

The following delicate recalcitration recently appeared in a paper of a neighboring city;

To the Editor of the Trumpet:

The infernal racket of the electrical "thrashing machines" now used as motor cars on North Pandemonium street, by the Citizens' Street Railroad Company, is an intolerable nuisance, worse by far than the braying of an army of mules, yet the city authorities tamely submit and quietly draw their salaries, while the wax continues to accumulate in their ears. This modest railway corporation now claims a perpetual right to all the streets of Pugville, and has employed gifted lawyers to plead its cause before the federal courts. In this case success is possible, for law is uncertain, but may God in His infinite wisdom prevent such a disaster.

HELEN BLAZES.

AN automatic track switch is in use in Newark, N. J. It is the invention of two street railway men and is said to give satisfaction so far.

## WANTED, A TICKET COUNTER.

The secretary of a large western road writes us inquiring if we know of a machine for counting the tickets returned from conductors. We can readily see that celluloid and aluminum tickets could be counted by using a rack with a scale of amounts, but it would seem a very difficult thing to improvise an accurate and satisfactory machine for counting paper and card tickets, especially after they have been carried by passengers and conductors, and more or less broken and crumpled out of shape. If any of our readers know of such a machine we shall be glad to be advised of it, and will take pleasure in illustrating and describing it. It would seem, however, as though it was one of those things in which manual labor cannot very well be supplanted by mechanical operation.

TEST OF THE WYANDOTTE & DETROIT RIVER RAILWAY PLANT.

The following figures, taken from a paper read by Jesse M. Smith, at the Montreal meeting of the American Society of Mechanical Engineers last month, will be of value for reference, as the road is a small interurban, very similar to many others.

The plant contained two 150-horse-power compound condensing high speed engines, made by the Phoenix Iron Works, of Meadville, Pa. Each engine is belted direct to a 150-horse-power Westinghouse generator. Only one engine and generator was run during the test. The load was not up to the maximum permissible, at any time during the test, so that the conditions were not favorable to economy. The engine was guaranteed up to a load of 225-horse-power. The Conover air pump and condenser was belted directly to the engine shaft. No changes were made in the plant for the test and it was run as in daily practice. The plant was three months old. Indicator cards were taken at intervals of five minutes during the 17½-hour test. All the testing instruments were carefully calibrated. The detailed description of the plant is as follows. We omit the data on fuel and boilers, because oil fuel was used, and the method of burning proved by the test to be inefficient.

ENGINE.

Phoenix Iron Works compound condensing; high pressure cylinder, 11¼ inches; low pressure, 20¾ inches; stroke of piston, 15 inches; two 78-inch fly wheels, weighing 2,445 pounds each; speed, 234.

AIR PUMP.

Conover Number 7; diameter, 15 inches; stroke, 7 inches; revolutions per minute, 67.

DYNAMO.

Westinghouse 4-pole Number 1; 111.9 kilowatts, or 150-horse-power rated capacity; standard speed, 625; speed when tested, 604.

CARS.

J. M. Jones' Sons, 16 foot; weight, 14,500 pounds; seating capacity, 22; motors, two Westinghouse 30-horse-power. Three cars in use.

ROAD.

10.5 miles long; 52 and 56-pound T-rail.

The variation of engine speed as shown by the tachometer during the regular run was 1.7 per cent, or from 233 to 237.

DISTRIBUTION OF POWER USED.

Power consumed by friction of engine, air pump, and boiler feed pump, with main belt off.....	9.22 I. H. P.
Friction of engine, air and feed pumps, and dynamo, with brushes off.....	11.34 I. H. P.
Friction of dynamo and belt.....	2.12 I. H. P.
Power consumed by engine, air and feed pumps, and dynamo, with brushes on and main circuit open.....	14.34 I. H. P.
Power required to charge fields of dynamo.....	3.00 I. H. P.
Rated capacity of engine.....	150 I. H. P.

Rated capacity of dynamo.....	150 E. H. P.
Percentage of engine capacity required by friction of engine, air and feed pumps $\frac{9.22}{150} =$ }.....	6.15 per cent
Maximum power developed by engine, as shown by indicator cards, during economy test.....	141.4 I. H. P.
Minimum power developed by engine, as shown by indicator cards, during economy test.....	21.27 I. H. P.
Average power developed by engine, as shown by 208 sets of indicator cards, during economy test.....	70.1 I. H. P.
Maximum volts developed by dynamo.....	520 volts.
Minimum " " " ".....	480 volts.
Average " " " ".....	501 volts.
Maximum amperes developed by dynamo.....	200 amperes
Minimum " " " ".....	47 amperes.
Average " " " ".....	67 amperes.
Average watts delivered by dynamo.....	33,567 watts.
Average electrical horse-power delivered by dynamo.....	45 E. H. P.
Average indicated horse-power delivered to pulley of dynamo, estimating friction of armature shaft to be the same as friction of belt.....	59.8 I. H. P.
Average commercial efficiency of dynamo $\frac{45}{59.8} =$ }.....	75.25 per cent.
Average number of cars in use during test.....	2.89 cars.
Number of passengers on cars during 17½ hours.....	1,014.
Number of single trips of cars.....	64.
Average number of passengers on cars per single trip.....	15.2.
Average number of passengers on cars at any one time.....	8.
Weight of 10 persons at 140 lbs. each.....	1,400 lbs.
Weight of cars.....	14,500 lbs.

Total weight of cars and persons.....	15,900 lbs.
Average weight in motion.....	45,950 lbs.
Average electrical horse-power per 1,000 lbs. of weight moved.....	0.98 E. H. P.
Average horse-power developed by engine per 1,000 lbs. of weight moved.....	1.52 I. H. P.
Average watts required per car.....	11,615 watts.
Average electrical horse-power per car.....	15.54 E. H. P.
Average horse-power developed in engine per car.....	24.25 I. H. P.
Average watts delivered by dynamo per horse-power developed in engine.....	478.8 watts.
Average watts delivered by dynamo per horse-power delivered to belt of dynamo.....	557.3 watts.

RATE OF SPEED OF CARS.

Length of road.....	10.5 miles.
Time of round trip, including 2 minutes stop at each end and at 16 railroad crossings.....	90 minutes.
Average speed per hour, including all stops, 21 miles in 1.5 hours.....	14 miles per hour.
Running time, allowing two minutes at each end.....	4.
1¼ minutes at each railroad crossing.....	4.
	90 - 8 = 82 minutes.
Average speed between stops = 21 miles in $\frac{82}{60} = 1.366$ hours.....	15.38 miles per hour.
Total car hours.....	50.25.
Time of test.....	17.33 hours.
Average number of cars in use during test $\frac{50.25}{17.33} =$ .....	2.89.

THE ELECTRIC OCTOPUS GOES.

The fraternity is indebted to the Trenton, N. J., Gazette, for a choice new synonym, a twin brother of the "deadly trolley." "The lazy tourist may now ride at his ease by the trolley road to Round Top, on the Gettysburg battlefield, all the suits to restrain the electric octopus having failed. The chief sufferers will be some impracticable sentimentalists and the hackmen's combine."

THE SPILLMAN TROLLEY EAR.

The accompanying cut shows different views of the Spillman trolley ear which the Ohio Brass Company of Mansfield, Ohio, has recently made arrangements to manufacture and is now offering to the trade. The ear has several features peculiar to itself which commend it to the users of similar devices. It is safe to say that the Ohio Brass Company will find a large sale for them.

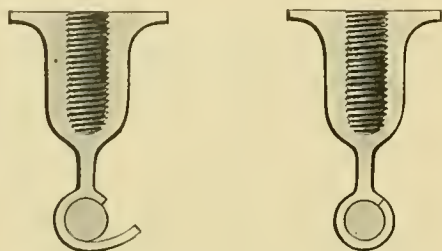

The great objection raised to the use of soldered ears, namely that of burning the trolley wire, the time and material consumed in soldering, the difficulty of adjusting the hanger on the wire after once in place, as well as the objection to many clamps, that of sparking when the trolley wheel passes over it, have all been overcome in the design and construction of this ear. It has been given a practical test, both on straight line and curve

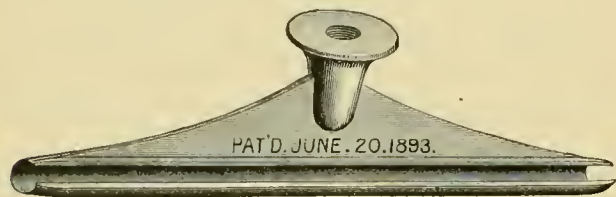

work, for over a year past, on one of the largest roads in the west, and its utility thoroughly demonstrated. The ear is screwed onto the hanger body and the trolley wire placed in the concave lip. The trolley wire is then pulled to the necessary tautness and the lip of the ear is compressed over it. A metal block is held on the back side of the ear, and a copper hammer used to do the forming with, beginning at the center and working toward the ends. On curves, the ear should be hung so that the side strain of the trolley wire is against the web. If it is necessary to adjust the hanger, the lips can be opened sufficiently to slip the ear along the trolley wire.

A SWITCHBACK AT DECATUR.

A stock company has been formed at Decatur, Ill., for the purpose of operating a switchback railway at Riverside Park, a resort owned by the City Electric Railway. The company is partly composed of those in the street railway, the moving spirit, being of course, General Manager W. L. Ferguson. It is expected that the investment will be a paying one in itself, aside from the increased travel on the electric railway, as the switchback has proved very profitable at other places where it has been tried.

THE FOURTH AT CHAMPAIGN, ILL.

One of the many ways in which the Fourth of July was celebrated by street railways is shown in the accompanying reproduction of a mammoth poster sent out by the management of the West End Park, of Champaign. The West End Park Company is simply an auxiliary

FOURTH OF JULY.



THE GREATEST CELEBRATION

... IN YEARS WILL BE GIVEN AT ...

WEST END PARK,

Champaign, Illinois,

The Greatest Summer Garden in the State.

THE PROGRAMME WILL INCLUDE

- Grand K. P. Band Concerts, Morning, Afternoon and Evening.
- Good Baseball Games, Morning and Afternoon
- Dancing in the Pavilion, Morning, Afternoon and Evening
- Casino Theatre, Grand Attractions, Morning Afternoon and Evening
- The Great Switch-Back Railroad, All Day and Evening

**Mons. Geller,** The Aerial Wonder, Morning, Afternoon and Evening

Grand Fire-Works Display, Magnificent Illumination, and Wonderful Stereopticon Exhibition at Night, And Many Other Attractions.

Hundreds of Electric Lights and Lanterns, Bowling Alleys, Shooting Galleries, Refreshments, Swings, Photographs Day and Night, Seating, Shelter Etc. Etc.

THE GREAT Midway Plaisance OF CENTRAL ILLINOIS.

**ELECTRIC STREET CARS** RUN TO THE GATES. Fare, 5c 6-Mile Street Car Ride.

All the Railroads, being aware of the number of people along their lines desirous of attending this great celebration, will sell Round Trip Excursion Tickets at Low Rates.

The Greatest Garden and the Greatest Celebration in the State.

of the street railway. The road is a very small one, but by virtue of a very energetic policy it carries a business that would be the envy of some much larger. Champaign is becoming a favorite point for excursions from all the surrounding country, and all on account of the efforts of the West End Park Company.

THE PARTRIDGE CARBON COMPANY.

At Sandusky, Ohio, is located the Partridge Carbon Company, of which James Partridge is manager and J. S. Speer secretary. Going into a field well occupied by similar concerns this company is making a magnificent record.

The specialties made, are electric light carbons and carbon motor brushes. The latter is the pet of the company and is rapidly getting the same reputation with users. By putting on the market only first-class material, the concern has gained its fame among its patrons both east and west.

It is claimed for the Partridge brush that it will wear a quarter longer than any other, and will keep the commutator in perfect condition. One company actually complained that the brush was too long lived! Both hard and soft qualities are made and samples are cheerfully furnished. One of the largest factors in the success of the company is the complete practicalness of the men, in technicality as well as business. Mr. Partridge is a man of ripe experience, and Secretary J. S. Speer a man of great business talent and foresight. The company is rapidly pushing its business under the most favorable conditions, with a factory capacity of 15,000 motor brushes and 35,000 light carbons per day.

**A PEORIA T RAIL LINER.**

A special form of brick for paving to T rail is in vogue at Peoria, Ill. Two types are used and both are successful. Figure 1 shows the small brick evidently for crowded or down town streets where as near as possible an approximation to the girder rail is necessary. The small brick is 8 inches long, 2 1/2 inches wide and 4 inches high. It is beveled to fit the rail foot with an inch and a

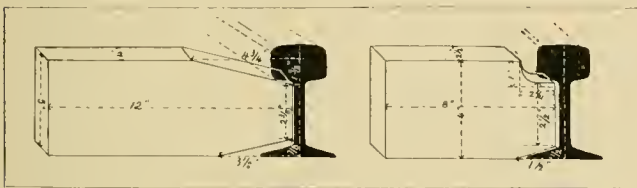

half bevel and curved to allow for the rail head. A 2 1/2 inch web is allowed for.

The larger brick is 12 inches long, 4 inches wide and 5 inches high. It is beveled for both head and foot. The head bevel is 4 3/4 inches and for the foot 3 1/2 inches. A 2 3/8 inch web is accommodated. The large brick is evidently applicable to streets where traffic is lighter or where there is no curve, crossing or switch work. To C. E. Flynn, electrical engineer of the Central Railway Company, we are indebted for the sketches and information.

**THE TIME CARD AND THE POWER STATION.**

The possibility of greatly improving the service from the standpoint of the public, and at the same time saving in power and in wear and tear of machinery, was well illustrated by the result of a recent move made on the Calumet Electric Street Railway, of Chicago. The change consisted in the adoption of a regular time table. Previously, starters had been employed to keep regular intervals between cars. While the adoption of the time table cut down slightly the speed and consequently the daily car mileage, it practically gave the public a much better service. The load on the power station was previously such that it was just too much for two units and not enough to load three. Of course the three had to be

run underloaded. The time table cut down the power necessary to such an extent that the two units could carry the load. Slight but profitable changes of this kind are often possible, and a competent manager will always be on the lookout for chances to make them.

**NEW JOHNSON WORKS AT LORAIN.**

The Johnson Company, of Johnstown, Pa., as is known, have for some time contemplated the erection of additional works in or about the city of Cleveland. It is now stated on good authority that they have purchased 3,600 acres of land for the use of their mills and on which to erect the homes for employes. Five million dollars is the amount which it is stated will be spent in the enterprise, and that the mills will be among the largest in the country. Details of the enterprise have not been given out, and it is not known what other departments, if any, than the rolling of girder rail, will be carried on in the new plant, but it is expected that the works will be very complete, and the undertaking on a large scale.

**A DETROIT ACCIDENT.**

What promised to be a serious and costly accident was narrowly escaped recently, when a Fort street motor car on the line of the Ft. Wayne & Belle Isle Electric Railway, Detroit, jumped the track, taking the trailer with it. The trail car was pulled but a short distance from the rack when the twisting strain threw it upon its side and

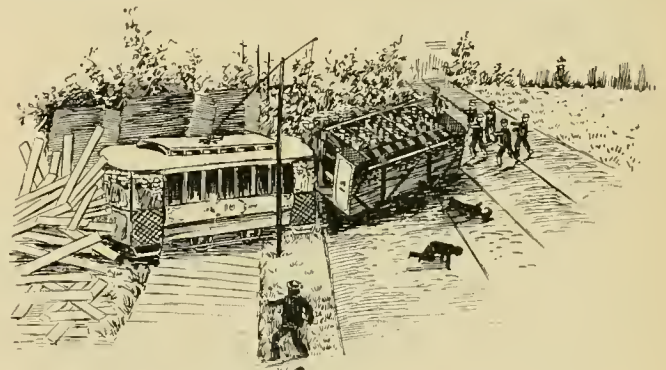

its seventy passengers into the dust. An investigation showed, that the train, consisting of a closed motor car and an open trailer, was running "on the multiple" a speed strictly forbidden by the management and dangerous, as shown by the sequel. No one was seriously injured. The most remarkable thing about the accident is the fact that the motor car retained its upright position.

NEW YORK'S L roads have acquired a phraseology of their own. On the upper west side the "L" road passengers are divided into patrons of the Ninth and Sixth avenue branches; and at Eighty-first street one morning, a guard on a Sixth avenue train, bound south, yelled out to the crowd on the platform, "Now then, youse Nines let them Sixes get aboard, why don't you?"

## GRAND RAPIDS RESORTS.

Bonded by bands of steel, Grand Rapids, Mich., has two beautiful summer resorts for the pleasure of the inhabitants of that busy city. One of the resorts is called North Park. It nestles close to Grand river at the north end of the Consolidated line. The other is Reed's Lake, a water gem in the setting of wooded hills which surround it. Both are ideal spots for rest and pleasure and bring to the street railway company many deserved



REED'S LAKE

shekels—this year more than usual. Heretofore, North Park has had no transportation facilities adequate to its need, but with the acquisition of the North Park Street Railway by the Consolidated, this trouble has been remedied, and the freest passage may be had to its pleasures by all inhabitants of Grand Rapids. The purchase not only enables the company to connect the two resorts, but is an advantage to both. At Reed's Lake all sorts of aquatic recreations are obtainable, together with band concerts and theatricals. At North Park, the native

## STREET RAILWAYS NOT COMMON CARRIERS OF PARCELS.

An interesting case is in the courts at Detroit, in which a passenger seeks to recover damage for loss of a parcel which he deposited upon the front platform of a car, taking a seat inside. When he left the car some passenger had done so before him and thoughtfully carried the parcel along, and hence a suit which was begun in a justice court, is now appealed by the plaintiff

to the circuit court. In the lower court it was held that the street railway was not a common carrier of parcels, and it is hard to understand how any one can expect to secure a reversal of this decision by going any higher. It has been repeatedly established elsewhere that street railways are not common carriers of baggage, and that passengers taking such into the car with them, do so at their own risk. In fact it is ordinarily understood, and so expressed in many ordinances, that the passenger is entitled to trans-



NORTH PARK

beauty of the place, its lovely grounds and its wholesome air will divide honors with the older pleasure ground. We show a sketch of the two resorts and only regret that many other street railway systems can not obtain as many natural advantages. However, as shown from time to time, even a corn field can be made to offer inducements of a surprisingly pleasurable nature.

portation at a certain price only for himself and ordinary hand baggage which can be carried in the hand or on the lap. Larger baggage in most places is charged for at an extra price, or is prohibited altogether, except on such lines as operate a light freight or express department, in which case, of course, they become common carriers; but the case in question is quite dissimilar and there can be no doubt as to the verdict being confirmed.

A RECENT order on the Atlantic Avenue Railroad Company's lines, of Brooklyn, N. Y., requires motormen to weigh not less than 168 pounds, to be 5 feet 9½ inches tall, of good moral character, and perfect eye sight.

THE Hammond, Whiting & East Chicago Electric Railway Company, since the coal strike, has put in oil burners as well as connecting with the natural gas mains.

TRAMWAY TRACTION METHODS  
COMPARED.



THE request of the town council of Newcastle-upon-Tyne, England, W. George Laws, borough engineer, has prepared a report on three systems of tramway traction for Newcastle. The systems considered, were horse, conduit, electric and cable. The report favors

the cable, but not without a thorough discussion of the merits of the electric conduit. The Budapest system is considered at length as being the only successful conduit system now working. Although a success at Budapest, Mr. Laws considers that there are reasons why it would not be successful at Newcastle. His report on the conduit system is as follows:

“This system has not as yet had an extensive trial in England, and, unfortunately, the limited experience obtained has not been very happy. Thus at Blackpool, where a conduit system was laid and promised well for a while, when taken over by the Corporation it gave so much trouble, owing to excessive leakage and deterioration of the apparatus, that for some time it has been worked by horses. One or two other small conduit systems in England have proved failures. There has, however, been an installation of the conduit system at Budapest, in Hungary, which has proved successful both mechanically and commercially, and where the cost per car mile has been brought down so low as to fairly bring the system into the field as a strong competitor. It will be fair, therefore, to take the figures of this system, making such modifications as are rendered necessary by the different conditions of the case to reduce it to English standards. Thus, Pesth is specially favorable for electric traction, being practically flat. The chief streets are extremely wide, sometimes 150 and 200 feet, and this allows the tram lines being run outside of and parallel with the ordinary traffic, while leaving ample room for carriages and carts alongside the footwalks. In consequence of this peculiarity, the speed of running is much greater than could safely be allowed in our narrow and crowded streets. Labor in Pesth is one-third less than in England, while fuel is one-fifth more. The chief facts in Budapest are:

Mileage open (single line) .....	14 miles.
Length of route .....	7½ miles.
Miles run, per annum .....	1,437,000
Passengers carried .....	11,000,000
Receipts, per car mile .....	\$0.2372
Expenses, per car mile .....	\$0.1264
The cost per single mile of—	
Construction .....	\$58,320
Equipment .....	\$13,365
	<hr/>
	\$71,685

The service on the electric route is at intervals of 1¼ minutes, and the average speed is 12 miles per hour—viz., 9.3 miles in the heart of the city, 11.16 in the residential parts, 15.5 in the suburbs. The cars are small,

to seat 20 passengers only, but with wide platforms, on which many stand. They have no seats on top. The population of Budapest is 520,000, but as the tramways are laid in Pesth, probably 300,000 is a fair estimate of the population served. Buda, on the other side of the Danube, is hilly, while Pesth is flat. The difficulty of working electric lines on any but very flat gradients has prevented the extension of the system into Buda, and the authorities are now enquiring into the possibility of introducing the cable system there. Commercially, the result in Pesth is that the shareholders have received dividends of 7 per cent in 1892, and 8 per cent in 1893, while a tax of 2 per cent is paid to the authorities for the concession. On a total capital of \$1,360,240 (which includes, however, some miles of steam lines), the earnings were, in 1892, \$334,819, of which, after payment of expenses, about \$117,126 was available as profit, and \$85,050 was divided among the shareholders. For 1893 the figures were:

Capital expended .....	\$1,360,240
Total earnings .....	395,263
Net earnings .....	156,716
Divided as profits .....	139,486

These figures have been taken from the officially published balance-sheets of the company.

There are some specialities of construction which must be noted as bearing on the applicability of such a system to English towns, and especially to Newcastle. For these particulars the committee is indebted to W. N. Colam, who visited Budapest in the course of business, with a view to see the details of a system that promised so well, and who has put the results of his investigations promised so well, and who has put the results of his investigations before you. The construction may be broadly described as the same as the cable system—viz., with a conduit underground to carry the moving power, but with this difference, that while in the cable system the conduit for the rope lies in the center of the way between the rails, in the electric system it is placed under one rail. At first sight it would appear as if this was a distinct saving in first cost by avoiding the central slot rail; but the saving is more apparent than real, as the actual cost of the way is about \$4,860 per mile more than in the central slot system. Besides this, however, there are disadvantages as compared with the central slot which are very serious and more than counter-balance the saving of the central rail. The central slot is not subject to the wear and tear from the flanges of the wheels since they do not run in it, and consequently there is no tendency to wear it down or widen it, and it remains permanently at its original width of 5/8 inch, and the edges remain unworn. With the conduit under one rail, on the one hand, the slot takes the flanges of the wheel and it is subject to rather heavy wear and the edges are rapidly rounded off and the slot widened. The width required to allow the electric “collector” to pass is larger than is needed for the cable “gripper,” for while all the power of the gripper may be conveyed by a plate 1/2 inch thick, the electric “collector,” though thinner, has to be protected on each side by “insulators,” and these

again have to be defended from wear by iron plates on either side. The result of this is that the original width of the electric slot must be at least  $1\frac{1}{4}$  inch or  $1\frac{1}{3}$  inch, rather more than double that of the cable slot. As a matter of fact, Mr. Colam found that in Pesth the slot was in no case less than  $1\frac{1}{2}$  inch in width, while this had in many cases, and especially at curves, been enlarged by the wear of the wheel flanges to 2 inches. This very wide slot, which is tolerable in Pesth, where the ordinary traffic need not cross the tram lines, except at a safe angle, would be a nuisance in our streets, where the horses wear caulkers, and where the ordinary cart and lorry traffic must work over the lines at all angles, while a bicycle wheel would drop through altogether with the risk of "short-circuiting" the conductors, and stopping the traffic on the line within that section. The electric system needs a quick means of getting at the underground conductors to remedy defects of insulation and for cleansing of the conduit, which is specially necessary to prevent accumulations of dirt or water, which at once stop the work by "short-circuiting." To provide this means of easily getting at the tube, two courses of brick in mortar are laid under the rails on the top of the concrete conduit, and when any stoppage occurs a rail is taken up, these bricks pulled out, and the necessary repairs done, after which the bricks and rails are replaced. This seems rather a clumsy way of working, and if it has often to be resorted to would become an intolerable nuisance in our crowded streets. It may answer in a town where the streets are so wide (as in Pesth) that the ordinary traffic has room to avoid the chasm laid open without being seriously inconvenienced, but with us, where every foot of the street width is used, and the ordinary traffic uses, and must use, the tram lines quite freely, such a system would be unworkable. There seems reason to fear also that the electric conduit, which seems to be specially susceptible to dirt even in a dry climate, would be more so in our wet and muggy weather, when the amount of mud that must pass through so wide a slot would cause constant trouble, and interruptions from that cause would be even more frequent. This seems to have actually been the case at Blackpool, and to have practically made the conduit system unworkable as first laid down, so much so that it is at present given up for horse traction, pending extensive alterations by which the corporation hope to overcome the difficulties. Snow, too, has been found very difficult to deal with on the electric conduit, and has occasionally stopped the lines for days together. The use of loose brickwork for the rails to rest upon makes the Pesth road rather a flimsy one, and such as would not satisfy us here. It seems to be only tolerable where the street width allows the ordinary street traffic to avoid the tram lines.

There seems to be good reason to suppose that the very successful financial result in Pesth is due to local conditions and could not be realized in England—or at least in English towns. The chief reasons that would increase the expense of working per car mile in England are:

1. The cheaper labor obtainable abroad—viz., 33 per cent cheaper for half-skilled labor, such as conductors, drivers, clerks, etc., and nearly 50 per cent cheaper for cleaners, greasers, and the like.

2. The very high speed allowed in the streets—viz., an average of 12 miles an hour, as against 8 miles, the utmost hitherto allowed in English towns. This at once increases the car mileage and shows reduced cost.

3. The difficulty of applying any electric systems to towns where there are hills to surmount. The increase of power required to take an electric car up a moderate hill is out of all proportion to the work done. Thus, a car which would consume 10 electrical-horse-power on the level would require 28 electrical-horse-power to carry it up 1 in 20, and 36 electrical-horse-power on 1 in 10, the speed on 1 in 20 being also reduced 40 per cent, and on 1 in 10 by 66 per cent; or, to put it in another way, to carry the same load at the same speed up 1 in 20 would require four times the power, and up 1 in 10, 11 times the power required on the level. This involves the further disadvantage that each car must carry motors powerful enough to surmount the steepest hill on the route, although they are useless dead-weight on the level. For instance, a car must carry motors in Clayton street four times more powerful than necessary, in order that it might be able to crawl up Westgate hill at one-third the speed. This is not very promising for electric traction in such a town as Newcastle or Leeds, and yet engineers on both sides seem to be agreed as to the fact of the unsuitability of electric motors for even moderate gradients. They differ only in their estimate of the waste of power, but, taking the most sanguine figures, it is practically fatal to cheap transit.

4. The moister English climate is unfavorable to the rather delicate apparatus, and promotes leakage of energy by keeping the conductors damp, and would also presumably require even closer attention to keeping the tube clean. A piece of damp paper (such as we see too much of in streets) would, if blown or dropped through the slot, and falling on the conductors, be enough to short-circuit them and stop all traffic on that particular section until its whereabouts was discovered and it was removed.

It is difficult to estimate the actual increase in cost per car mile for each of these items, except in the case of No. 1. Allowing for dearer labor and cheaper coal in England raises the car mile cost by \$0.015—viz., from \$0.1264 to \$0.1414. The difference produced by No. 2—that is the lower working speed here—can only be inferred by working out the reduction in car mile cost made by increasing the speed on the cable roads; but taken in this proportion would be about \$0.016. The difference caused under No. 3—viz., the disadvantage on gradients—would depend greatly on the proportion of steep streets worked on the system. Assuming that in Newcastle the proportion of steep gradients is one-third of the whole, the total power required would be increased as 5 to 3, which would mean an addition of about \$0.015 per car mile. Under No. 4—the influence of climate on the system—there is no means of making



an estimate. It might be so great as to stop working altogether, as at Blackpool. Putting all these together, the probable cost is raised to \$0.1724 per car mile, which corresponds pretty closely with American experience, where the best information that can be got puts the cost per car mile of electric traction at the best at \$0.03 below horse traction, which brings it to \$0.21 in America, where prices of labor are high. Assuming horse traction here, in Newcastle, to cost \$0.20 per car mile, which is about the figure, that would bring the electric system to \$0.17 as compared with \$0.1724, as obtained above. There is one point which should not be forgotten in comparing the results at Pesth with those, say, in Edinburg—viz., that the average fare per passenger is \$0.028 in Pesth, against \$0.022 in Edinburg. To bring the fares down to English standard would at once reduce their traffic receipts by \$58,320, and take just 5 per cent off the dividends earned. The fare system abroad is somewhat different to that prevailing in England. We stop to pick up at any point where a passenger may call; on the Continent the "stations" are fixed, and cars do not stop between. In Pesth they have also a plan of using fare books, by which a considerable saving is effected. Thus, though their lowest single fare is \$0.04, return and season tickets bring down the average fare to rather under \$0.03.

### THE CABLE TRACTION SYSTEM.

In this case one has surer ground to work on, because the system has been extensively tried both in America, England and elsewhere, so that the costs both of construction and working are pretty well known \* \* \* The special feature of the cable system, that every additional car put on only adds a few pounds of coal consumed at the engine house, but does not increase the fixed charges, while it does increase the car mileage, renders it especially applicable to a growing traffic and to the further development of traffic.

The disadvantages of cable traction are:

1. The high cost of construction, which is about \$48,600 per single mile—less, it is true, than electric conduit, but double that of horse lines. The cost of equipment, however, is only \$4,860 per mile, as against \$13,365 on the electric system. A cable car, complete, costs about \$1,070, while an electric car costs about \$3,400.

2. The central rail is a further interference with the streets, and with the ordinary street traffic. \* \* \* It seems to me that as to cost of construction there is not much to choose between the two systems. The electric, apparently, has cost more in Pesth, in spite of cheap labor; but there seems no real reason why it should. The work to be done is practically the same—viz., to lay a conduit for the conductors or cable and the rails. There should be little or no difference in first cost. The cost of equipment is certainly much larger for electric haulage, and must necessarily be so, since motor cars cost about three times as much as cable cars, but this is a matter more for the lessees than the corporation, as equipment is a lessee's cost. It is only important as

affecting the amount of money that must be earned to pay interest on capital. Cost of working is the next consideration, and here the advantage is in favor of cable haulage. Budapest shows a very good result; but, as has been shown, this result has not been realized in America, and is not likely to be realized here, while, on the other hand, both English, American and European experience has confirmed the low cost per car mile of cable traction, and the fact that the larger the mileage run the less the average cost. The cost of cable haulage in America on the larger lines is put at under \$0.10 per car mile, which, allowing for American prices, would correspond to about \$0.08 here. Where it has had a favorable chance, as at Brixton, that result has already been realized, and on popular fares, too. Applying Edinburg results to Budapest figures, shows that with such a service—viz., 1 1/4 minutes, and carrying the same number of passengers—the cable would be worked even below \$0.08, thus beating electricity on its own ground."

The above report may give a few pointers to conduit inventors as to why capitalists will "persist" in clinging to cable traction for heavy traffic. The fact is, not one conduit inventor in ten, seems to realize that the cable system is a possible competitor in places where it is proposed to build conduits. The electric conduit may be made a mechanical success and even a commercial success, as it is at Budapest, but still the third question comes in as to whether it is as good an investment as a cable road would be in the same place. Mr. Law's report seems to show that it is not.

### TOLEDO'S TRANSFER.

In common with many other managers, W. S. Jewell, of the Toledo, O., Consolidated Street Railway Company, has found many a slip—not transfer slip—between the transfer and the transferred. The reprehensible

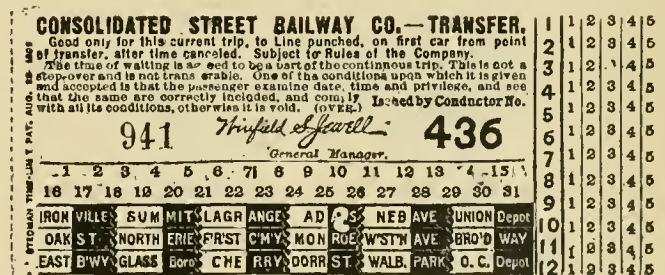

practice of getting two rides, not continuous, for one nickel, made some sort of change necessary, and the ticket shown in our engraving is the result. In form it differs only in the arrangement of the figures. It is a neat affair, not too large, and elastic enough for general use without being too general in its terms.

SUPERINTENDENT PEARCE, of the Negaunee & Ishpeming Electric Railway, is a lucky man. He recently drew a \$135 bicycle and a horse and cutter at a raffle, at the expense of one dollar.

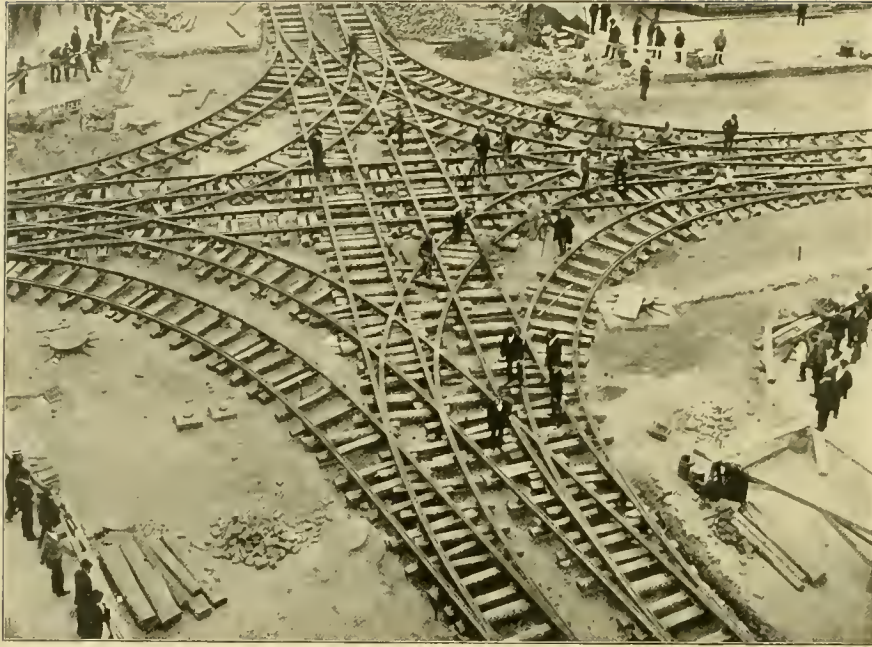

SOME FINE SPECIAL TRACK WORK AT ROCHESTER.

The corner of State, Exchange and Main streets, at Rochester, N. Y., is the down town terminus of twenty-two lines. Four thousand cars pass that point daily. President J. N. Beckley, of the Rochester Railway Company, therefore planned wisely and well when he made arrangements for some special work, that probably has no equal in this country. The contract with the Johnson Company called for a double track crossing, with switches both ways. The general plan of the crossing is shown in our engraving, made from a photograph taken before the paving was laid. The guard rails stand 10½ inches above the ties at the highest point of the flange. They have electrically welded chairs three feet apart, and the rails together with the chairs weigh 100 pounds to the yard. The chairs have a bearing on the ties of 8

Special care was used in designing, to provide easiest curvature upon tracks most in use. There are 1,348 feet of single track in this piece of work, and the weight of the whole is about forty tons. The electrical return is a continuous insulated Number 0000 copper wire, fastened with rivets made specially for this purpose. They were made by the railway company, and are the invention of Alfred Green, electrician, and Wm. Rosborough, superintendent.

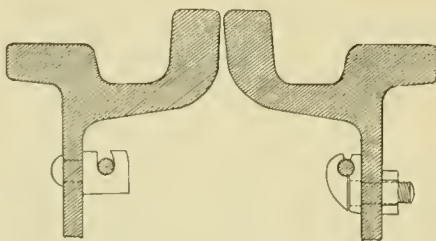

FASTENINGS FOR RETURN WIRE.

by 10 inches. A cross section of rail, chair and joint plate is here shown. Eight 1-inch bolts are used at the joints. Transition arcs are used at the curves in order to allow a uniformity in tongue switches. The switches are all curved for 100 feet radius. The tongues are held in place by a single set screw and washer, and can be removed without disturbing the adjacent pavement. The whole work rests on a concrete bed thirteen inches in thickness, seven inches of which is below the ties. All joints between rails and between rails and paving were carefully filled with paving pitch, thereby excluding moisture.

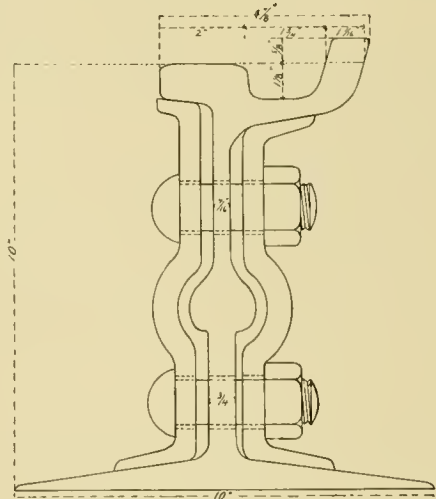

SECTION THROUGH JOINT.

In laying, the curves were carefully checked with the transit, and everything went along without a hitch. The work was designed by Houston Barnard, the engineer of the Rochester Railway Company, and built by the Johnson Company, of Johnstown, Pa. It is one of the most thorough pieces of special crossing and curve work in the country, and is bound to be followed by many more, as nothing but the very best construction will give satisfactory service under electric motors running on frequent headway.

**ELECTROLYSIS OF POTATOES.**

"I have a protest," said "Farmer Beettops" as he leaned up against the newly whitewashed wall of the engine room and looked reflectively at the engineer.

"Well, take it to the office."

"But I want to know first ef its right."

"Out with it then," said the engineer.

"Wall, I wanter know ef 'lectricity eats wires and water pipes ef the stuff won't kill my taters."

**ELECTRIC LAUNCHES AT PUEBLO.**

Superintendent W. A. Martin, of the Pueblo City Railway, reports that his company has purchased, through its receiver, H. E. Chubbuck, one of the launches used at the World's Fair, and it is now making regular trips on Lake Minnequa. This lake is the largest in Colorado, and situated about three miles south of the Pueblo court house. The launch makes trips every twenty minutes. The fare is ten cents. The boat is No. 6, and those familiar with the World's Fair launches, will recollect that this was the first electric launch that ever turned a wheel in the lagoons of Jackson Park. The batteries are charged from a motor generator driven from the railway circuit.

**PROPOSED INSURANCE LABORATORY.**

The western underwriters are considering the matter of establishing an electrical bureau at Chicago for the purpose of collecting information regarding electrical fires, testing electrical apparatus and appliances, and disseminating useful information in regard to the safe use of electricity. Such an institution would of course require a complete laboratory for making all necessary tests. The bureau would be a great benefit, not only to the insurance companies but to all others, and it is to be hoped that the plan will be carried out. It would act as the electrical adviser for all the western country, which comprises about twenty states and territories. At present there is absolutely nothing of the kind, and while the laboratories of various colleges and universities may in some cases be able and willing to make the desired tests or collect such information, such work should manifestly be in the hands of a corps of men who make it their regular business.

AFTER having been in court for thirteen years, a Mrs. Freeman has been awarded \$300 for the death of her husband, which was alleged to have been caused by an accident on the Dry Dock, East Broadway & Battery Railway Company, of New York.

THE new rapid transit commission of New York has appointed Lewis L. Delafield secretary, and Wm. Barclay Parsons chief engineer. Ex-corporation counsel, H. R. Beekman and H. B. Boardman, were chosen as counsel for the commission.

**WRIGHT'S NEW METHOD OF MOUNTING CARS ON SINGLE TRUCKS.**

The West End Street Railway, of Denver, is equipped for winter service with sixteen and eighteen-foot cars mounted on rigid single trucks. They were found unsatisfactory because of the jolting when going around curves and on and off switches. Indeed it became a question whether they would not have to be abandoned in favor of thirty-six-foot double truck cars. To make this change meant an increase in the coal bill. S. Roy Wright, the superintendent, made a careful study of the matter, and finally hit upon a plan that overcame the objection to a degree that exceeded all his expectations. It was first tried on an eighteen-foot car. The plan is simply to allow a slight swivel motion of the car body,

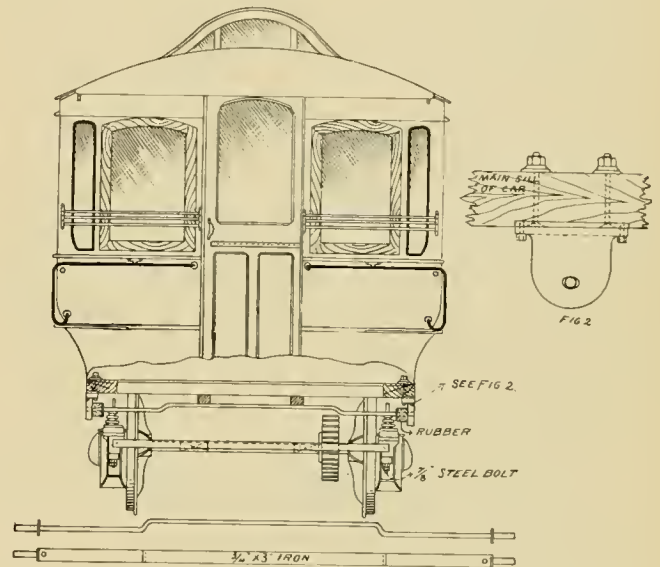

this motion being cushioned by rubber buffers. The accompanying drawings show it as applied to a Bemis truck. It can be put on any make of single truck. A three-quarter by four-inch iron forms a support for the car sills. This iron has its ends rounded so as to extend through plates attached to the side sills. When it is necessary to take the truck from under the car it can be done by simply disconnecting the motor and jacking up the car. There is not a single nut or bolt to be removed, thus making a great saving in time. The first car so equipped has been in service over three months without requiring any repairs, and it goes around curves and over switches with almost as little jerking as the thirty-six-foot double truck cars. It would seem that this plan would save both the track and the car body.

THE official returns regarding the working of the electric tramway at Marseilles, France, show that it is being greatly appreciated by the inhabitants. During the first two months of this year, the number of passengers carried over the lines—which is about five miles long—amounted to 645,384, as against only 423,267 in the corresponding period of last year.

THE JOHNSON-LUNDELL ELECTRIC RAILWAY.

An underground system, devised by E. H. Johnson, president of the Interior Conduit & Insulation Company, and Robert Lundell, of dynamo and motor fame, has been operating on an experimental road in New York City for several months. The track is of the ordinary construction, except that a third rail is used to take the place of the trolley wire. This third rail is uninsulated save by the pavement. It is divided up into short sections insulated from each other. These sections are cut in and out by electro-magnetic devices as the car moves along. The switches are located in water tight boxes alongside the track. The current is taken from the third rail by a steel brush. The voltage is 300. A small storage battery is carried to supply current at crossings and switches, and to act as a reservoir into which the current from the motors can be turned in making stops, thus acting as an electric brake. Probably the feature that is of most interest to practical men is the motor. It is of such construction that the advantages of series-parallel control are made possible with but one motor. This is done by having two armature windings in parallel with each other. These two sets of windings are connected to different commutators, one at each end of the armature. It is evident that these two windings can be treated as the circuits of two separate motors, and can be

thrown in series or parallel with the same results as are obtained with two motors. This is an important device, and does away with one of the principal present objections to single motor equipments. The motor is connected to



a shaft carrying bevel gears by a sprocket gearing. A bipartite screw coil placed on the armature shaft saves jerking in starting. Owing to the fact that very few technical details are given out by the company in regard

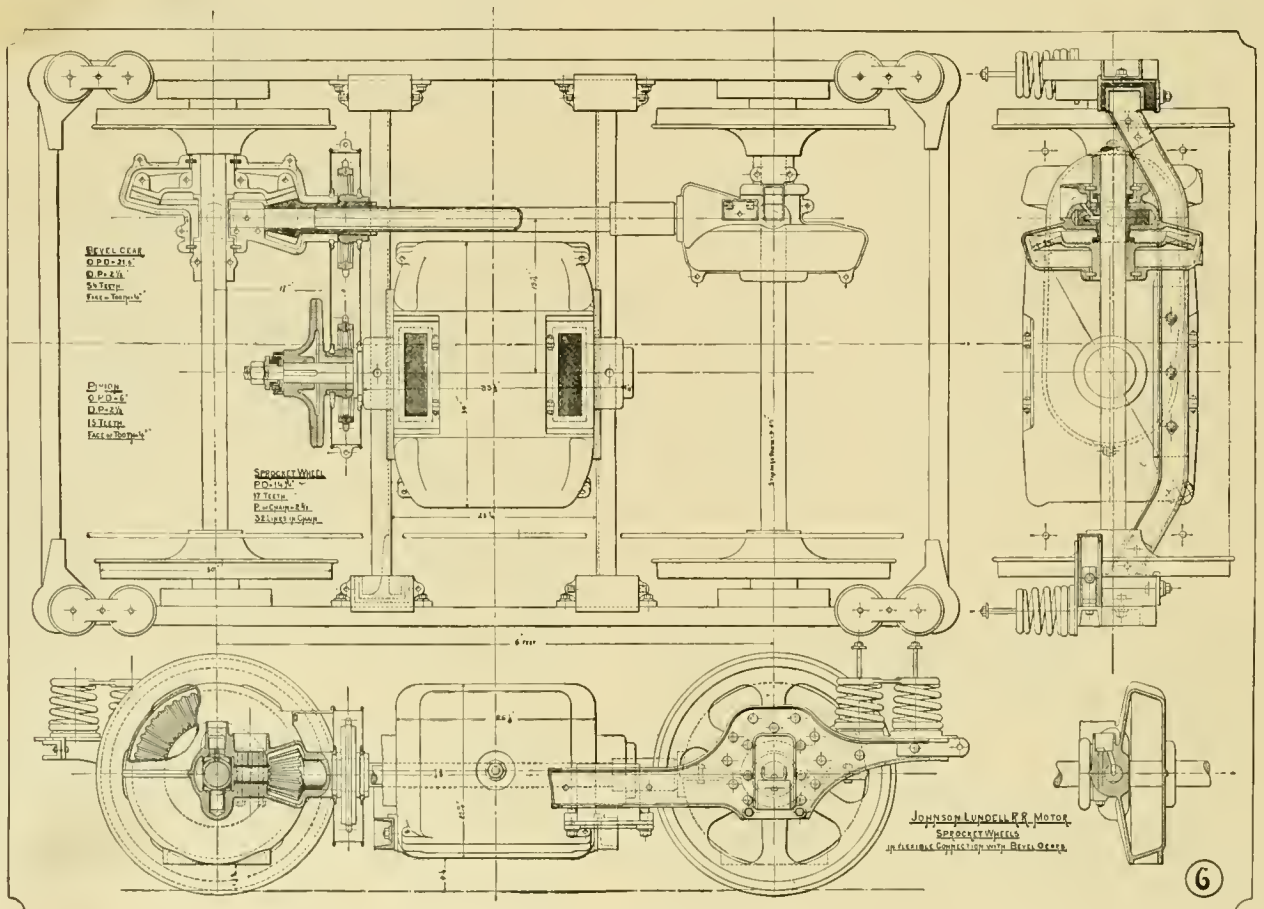

PLAN AND SIDE ELEVATION OF TRUCK.

to the majority of the radically novel points in the construction of supply conductors and motors, it is impossible to form an intelligent opinion as to the merits of the system. The inventors have a reputation of being emi-

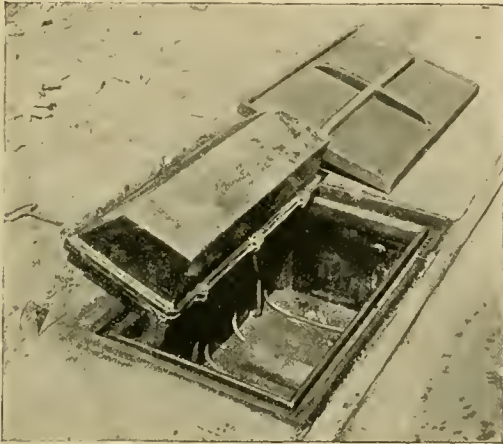

nently practical men, gained from their work in the past, and there is therefore some reason to think that this system will, in a measure, correspond with previous efforts.

INTERURBANS IN THE WYOMING VALLEY.

The ultimate usefulness of electric railways for long distances has been heretofore discussed by the REVIEW holding the idea that in usurping the traffic now universally controlled by steam roads, the advance would not be by building long lines outright, but by connecting different smaller systems. This has been proved to a large extent by the consolidations of the last few years, and still there are more to follow.

Ohio and Pennsylvania offer the best fields for interurban electrics as the towns of these states are situated closely enough together and have both enterprise and ability to carry out the undertakings.

Wilkes-Barre and Plains with another line in the city. The Wilkes-Barre & East Side Railway Company runs through Millvale, Port Blanchard and other villages to Pittston and from there to Pittston Junction with a franchise yet to be built upon to Duryea. This line will finally connect with the Scranton Traction Company's system at Taylorville. The Scranton Company, as is well known, has a magnificent interurban to Carbondale, as heretofore described in the REVIEW. The distance over the outlined trackage from Nanticoke to Carbondale, over the two systems, is 44 miles of main line, and counting the branches leading to other villages, 85 miles. Forty-five towns are connected, and a population of 250,000 is given the inestimable blessing of safe and rapid transit. The Scranton & Pittston Traction Company has a proposed route from Scranton to Pittston, via Minooka, Moosic and Avoca. The scheme of connection is almost certain to be carried out within this year, and a lesson of progress may be looked for from the Wyoming Valley.

HIS BUSY DAY.

A prominent superintendent in the east has been working for a year or more on an improvement in street car operation, and recently put his plan in successful use. The REVIEW has watched the development with great interest, and in its efforts to secure a complete account for its readers, has written the gentleman in question an average of twice a month. His last answer is full of hope and gives a glimpse into a busy life which will be recognized by many of our readers. He says:

"Yours of the 28th received. I note that 'there is no rest for the wicked.' It also strikes me that your rain descends upon the just and the unjust. As you say, at this time of year I am very busy. What with concocting a cure for rheumatism in the wrist, entertaining conductor's brothers-in-law, devising schemes for a transfer system that transfers only the original package and inventing a time card that will admit of the ladies going back two

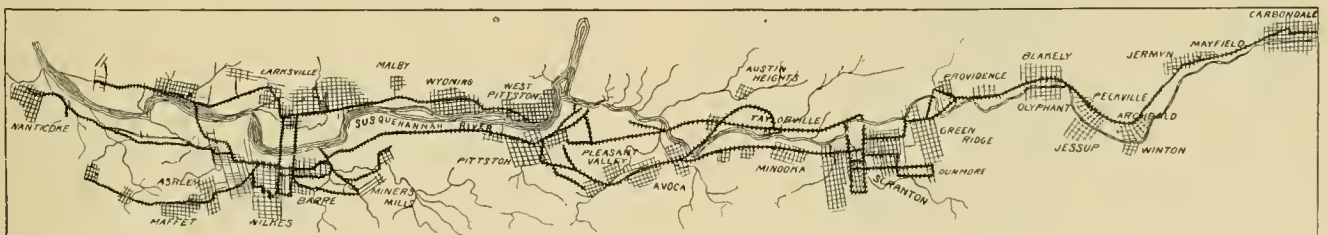

CHAIN OF INTERURBAN ELECTRICS IN THE WYOMING VALLEY.

Our map of the Wyoming valley shows what will be done very shortly by building a few connecting links of track and wire. Starting with the Wilkes Barre & Wyoming Valley Traction Company, which has 54 miles of track in operation, the system extends to Nanticoke, eight miles in one direction. The Coalville Passenger Railway, of the same system, runs five miles to Sugar Notch, and the Wilkes-Barre & Suburban lines connects

blocks to kiss the baby, thrown in with regular routine work, I am busy, but shall certainly try to make the effort to 'help save the country.'"

FRENCH and German municipalities have begun trying to compel street railway concessioners to put in mechanical instead of horse traction. This is the case at Havre, Marseilles and Nancy.

DEDERICK'S FENDER.

We once thought that all the possibilities had been exhausted by fender inventors, but were somewhat shaken in that belief by the appearance of the fender herewith illustrated, which is the invention of Levi Ded-

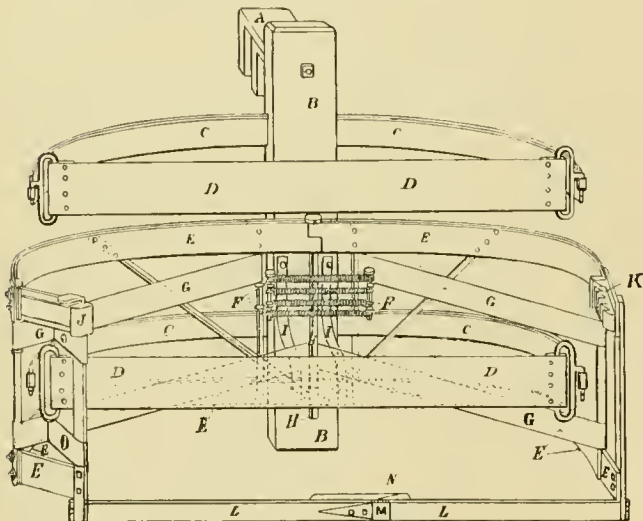

erick, of 23 Wilson street, Albany, N. Y. The fender operates by closing two pairs of arms around the victim. When in use on a car it is set and appears as in Figure 1. The person caught strikes first against the trigger LL,

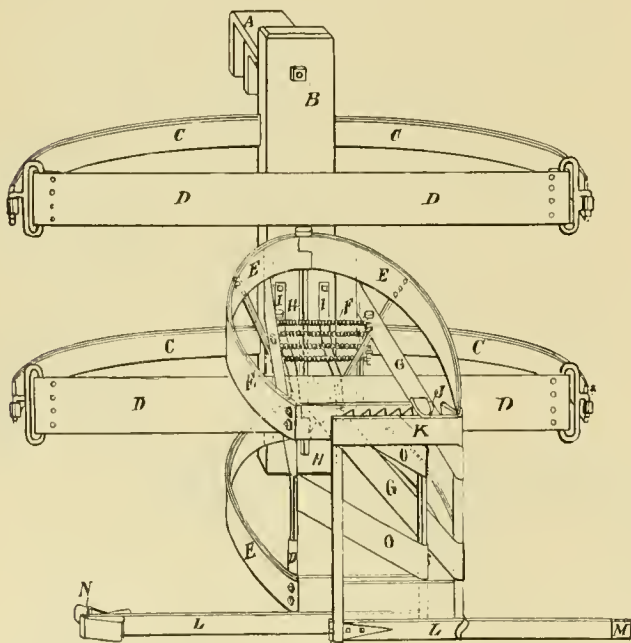

and it buckles inward. He then strikes the buffer DD, and before he rebounds the arms close around him and he is safe. The buffers G on the arms prevent his being hurt by the arms and also hold him fast. Children are caught by the narrower lower arms only. We are informed it has given good results in experimental trials on the Albany Railway.

RESUSCITATION AFTER ELECTRIC SHOCKS.

The eminent electrician, Dr. A. D'Arsonval, maintains that persons being revived from severe electric shocks should be treated as if from drowning. Electric shocks have two effects on the system. In one case the result is lesion or destruction of the tissues, caused by the disruptive and electrolytic effects of the discharge. In the other case there is simply an excitement of the nerve centers which causes an arrest of respiration and fainting. In the latter case, death is only apparent, and the person can usually be revived by the same treatment as that given to one drowned. Artificial respiration should be practiced, care being taken that the tongue is loosened, so as not to hinder breathing. He cites an instance in which a man was in this way revived who had been stiff for over an hour from the effect of a shock, the shock having lasted several minutes.

FIRE APPARATUS ON ELECTRIC ROADS.

The common council of Lynn, Mass., recently passed an order for the investigating of some method of carrying fire apparatus over the Lynn & Boston Electric Railway tracks to outlying districts and suburbs. The fire department, after due consideration, regarded the matter in Lynn's case impracticable. This, however, does not neutralize the value of the idea. The suggestion is eminently a good one and in many places both in larger and smaller towns would greatly expedite fire service. When fire apparatus is needed at a given point it is needed badly and immediately and a few seconds lost may mean considerable damage. Traveling on the tracks would not be more dangerous than traveling on the road, and a department employe could in a few days become a good motorman for emergencies. Let our inventive geniuses design a fire department trolley car and see what can be done in this regard.

STEAM AND ELECTRICITY MIXED.

The Beaver & Ellwood Railroad, a steam road of western Pennsylvania operating three miles of road between Ellwood Junction and Elwood City, has been using both steam and electricity for some time. The electric cars carry the passengers and the switching and freight haulage is done by steam. The freight men are given certain schedule hours in which to do their work and the balance of the time is given over to the electric car for the passenger business. This car makes fifteen trips a day over the three miles of road. The company has found the arrangement satisfactory and it is well received by the traveling public. The road connects with the Pennsylvania company's system at Ellwood Junction, the Lake Shore system at West Ellwood, and the Baltimore & Ohio at Ellwood City.

### CABLE EXTENSIONS IN NEW YORK.

The Scientific American, in presenting the accompanying view of the work on the Ninth Avenue Cable road in New York, comments on it as the last act in the conversion of a roadway originally constructed for horse drawn vehicles into a doubled-storied avenue in which two forms of mechanical traction are used. The scene



is on Ninth avenue, under the Ninth Avenue elevated. The Ninth avenue extension is a part of the Broadway Cable line, owned by the Metropolitan Traction Company. It enters Ninth avenue at Fifty-third street and runs north on that thoroughfare to Ninety-eighth street. Another branch of the Broadway line is being built on Lexington avenue, from Twenty-third street to Seventy-ninth street.

### STEAM AND ELECTRIC RAILWAYS.

In the "railway number" of the Independent, Thomas L. Greene contributes an article on the above subject, of which the following is an abstract:

The development of electric railways into what may be called suburban systems is having certain results not at first foreseen. The comparative cheapness of electric propulsion cannot be denied. One result of the joining of near-by villages and towns by electric roads is that the steam railways, which have for years carried the local travelers who journeyed from one station to another, have felt the competition in some cases seriously. For a ride of but a few miles it is clear that a surface road has a number of important advantages. If the speed be reasonably rapid, and electricity allows of that, the traveler will have to spend very little if any additional time on the journey, and any slight excess of time required is more than made up by the privilege of beginning his journey at any hour which may suit his convenience. Perhaps the electric cars pass his door, while the steam railway station is some distance away. So, too, at his destination, the electric car will land him at whichever portion of the city or village he may wish to go. Pos-

sibly in cities this advantage may save him an extra fare which he might have to pay some street road from the railway station. An instance of the effect of this competition is seen in the service between St. Paul and Minneapolis, Minn. The distance between these two cities is about ten miles. The travel between them had been accommodated by local trains run at convenient hours throughout the day by the two principal steam railways. The completion of the electric street railway system between the two cities, however, was followed by such a complete falling off in the travel upon the steam railways that they practically abandoned their local service. In Connecticut, where the steam lines running through populous districts were threatened by the competition of electric roads, there has been a long legislative wrangle over the equities involved.

The situation is such that the steam railways must expect to lose a certain proportion of their station-to-station travel. Rapid transit in the streets and along the highways has become so important from a public point of view that it is not easy to see how the steam roads can retain their old number of short-distance travelers; nevertheless, the competition is unjust. The steam railway has spent large sums of money for its roadbed, equipment and plant, and, as the owner of real estate in the town or county, usually pays a large proportion of the public taxes. On the contrary, the electric road usually pays nothing for its right of way, because the privilege of laying its tracks on the public streets or on the public wagon roads without charge is commonly granted to it; and in these privileges it has a material advantage over the steam road, which, indeed, is often indirectly taxed to support its rival through street or road repairs, or something of the sort.

In another way, also, the electric road has the steam road at a disadvantage. No more precautions were necessary to be taken by the horse car company than by the owners of private wagons; but rapid transit has changed these conditions, while the slow law has not caught up with them. As yet the electric roads have not been compelled to take any precautions such as experience has shown to be necessary on steam roads, and which the law makes obligatory upon the latter. The electric railways are not obliged to put up any signal apparatus or to protect the public in any way against the new danger—such, for example, as fencing off its tracks, a thing the steam road must do often at large expense. Safety both for electric and steam passengers demands the enactment of laws in every state requiring that no electric road shall cross a steam railway at grade, unless the most approved signals and derailing switches are set up.

But while the competition of electric roads between villages is felt by the steam railways which have heretofore carried all the travel, that statement does not exhaust the subject. Even in regard to this same competition it must be remarked that frequent and rapid transit creates travel, and that more people journey from village to village under those circumstances than would take the steam trains, if the latter were the only means of inter-village

conveyance. More than that, it is highly probable that the effect of the extension of electric roads outside of cities will in the long run benefit the steam railways and facilitate their business. Not every electric road competes by running alongside a steam railway. A great many of them are built to connect distant villages, which have no steam communication, directly with some railroad station. In all such cases, the value of the electric roads as a feeder of the steam railway is rightly considered great. The demand for electric connections is sure to be heard from all the interior towns and villages of local importance. It is possible that the expansion of the new system of street and road transportation, when once extended into the rural districts generally throughout the country, will have important effects upon our political economic problems as well as upon the revenues of the steam railways, which must continue to be the only method of travel for longer distances.

The argument of Mr. Greene's in regard to the "unjust" competition of electric roads will hardly stand. While it is true that the steam road must buy its own land and pay taxes on it, it is also true that the electric road also pays taxes on its roadbed and plant. The fact that the electric road is given its right of way is abundantly paid for by the cheaper service of the electric road, which is often less than one cent a mile. The electric road requires only eight feet of roadway, and that eight feet can usually be given not only without any material loss to the public, but with a great gain. It might also be mentioned that there are numerous cases where inter-urban electric roads own a part or the whole of their right of way. In regard to signals and safety regulations, practice has not demonstrated the need of them. It is safe to say that suburban and interurban roads are the safest in existence to-day. Grade crossings are chiefly dangerous when the steam road, by a short-sighted policy, forces the electric road to jump the steam tracks.

The fact, is, that the electric road is from its very nature cheaper and more convenient than the steam road for a certain class of travel. To try to even up the difference between steam and electric roads by legislation would be like trying to make it possible for the stage coach to compete with the railroad by the same means.

#### A SOUTHWEST CHINA TRAMWAY.

Georgetown is an English, or rather an Anglicized settlement on the Penang Straits, Southwest China. It is the most flourishing of the Straits settlements and a place of considerable commercial importance.

Its most distinguishing feature is, however, a steam tramway which runs from the quay through the principal streets, terminating in two populous villages. The inducements to build the line were the considerable freight and passenger traffic, the latter of which is developing as the natives get used to the "devil machine."

The rolling stock and plant were furnished by Kerr,

Stuart & Company, London, under designs of F. H. Gill, C. E., the engineer of the firm. The road is five miles long and is laid with steel ties, the only material proof



CONSTRUCTING THE LINE.

against the ravages of the voracious native ants which devour everything except bamboo, teak and iron. Of these, bamboo is too light and teak too expensive.

Clearing the right of way was not child's play, as a dense growth of palms had to be cut away. To do this work a big traction engine was employed to "pull stumps" a la Western American practice.

The peculiarities of the traffic demanded a style of rolling stock absolutely unique, namely a combination passenger and freight car. The cause of this was the fact that passenger traffic is valuable only on holidays. At these times the whole population of the entire district assembles at Georgetown, while on ordinary days tout le monde stays at home. Therefore the cars are made with a side entrance and on the two-story plan, the first floor being first-class and the second, second-class. The conductor stands in the middle and commands the only means of egress and exit. This is absolutely necessary on account of the wild and restless nature of the passengers, who take every means of "beating their fare" just

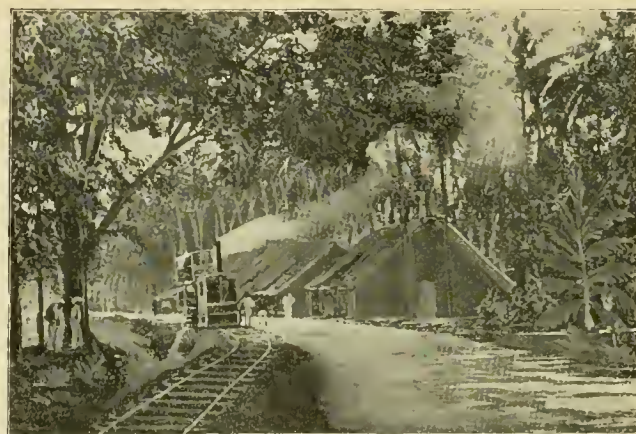

SCENE ON THE TRAMWAY.

as ordinary American citizens are wont to do. The freight cars are fitted with a movable roof which may be hoisted and thus transformed into fourth-class coaches.



They run on four wheeled trucks. Seats are not provided, as the native is unused to this luxury and contents himself on the hard floor.

The locomotives are of the boxed-in type so familiar in England, and built especially for the purpose. The engineer's life is not all one happy dream, as a single incident will show. One night an engine was left as usual in its shed and the fire put out. On trying to raise steam next morning the engineer worked unavailingly, but could not account for the low pressure. Finally the fire was raked out and the boiler examined and the cause of the delay discovered. The boiler tubes were found crowded with snakes which, no doubt, attracted by the warmth had taken up an abode there over night. They were nicely roasted. Another inconvenience is the native festival which is often recurrent. At these times the natives get beastly drunk and lie down at will along the track. The fireman then has to run ahead at intervals and pitch a drunken coolie into the ditch.

Although the cost of the plant was considerable, it is said that the tramway is a paying concern.

**THE LARGEST ARMATURE STAR IN THE WORLD.**

The accompanying engraving represents one of a pair of what are probably the largest armature stars or carriers in the world. A pair of them have recently been made by the Wells & French Company, for the Seimens & Halske Electric Company of America. They are to be installed at the power house of the Toronto Street Railway. The machines when completed will weigh about 60 tons each and have a nominal capacity of 1,200 kilowatts or 1,600 electrical-horse-power and will be over compounded for a 12 per cent line drop. They will be

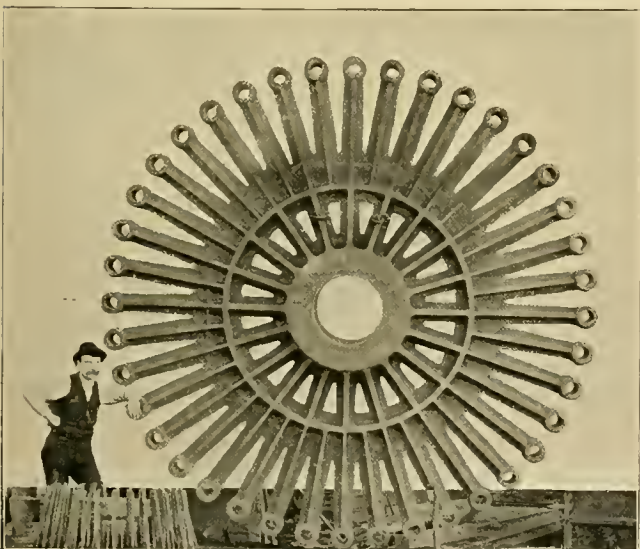

LARGEST ARMATURE STAR IN THE WORLD.

direct connected to a pair of horizontal cross compound condensing engines running at 80 revolutions per minute. The stars are 13 feet in diameter and weigh something

over 10 tons each. The brush carriers, made by the same concern, will be 14½ feet in diameter. The castings came from the mould without warp, crack, flaw or blow hole, and the Wells & French Company is to be congratulated on the success of the first trial at making these large and difficult castings.

**A MEXICAN AIR LINE.**

A correspondent of the REVIEW who is now traveling in Mexico, sends a sketch of a novel means of transport-



A MEXICAN AIR LINE.

tation found in operation several hundred miles back from the coast. It is the well known form of ropeway and is used for the transportation of both passengers and freight. The line crosses two very deep canyons and the intending passengers need to take a very level head on their shoulders, as any sudden dizziness arising from peering down the more than 1,000 feet of space could hardly result other than in a fatality. Nevertheless the air line is well patronized and after one has become accustomed to the ride it is said to be exhilarating and even enjoyable. Two passengers constitute a load and no difficulty is experienced in enforcing the "no seat, no fare" rule.

THE Richmond Electric Club, Richmond, Va., is one of the newest organizations of electricians. The officers are: George A. Tower, president; T. L. Martin, vice-president; Harrison Tabb, secretary; F. J. Craigie, Jr., treasurer. The REVIEW extends congratulations.

THE strike that failed occurred down at Pine Bluffs, Ark., last month, when the force of 15 conductors and drivers walked out. It took 15 minutes to get 15 men to take their places and the strike was declared a dismal failure.

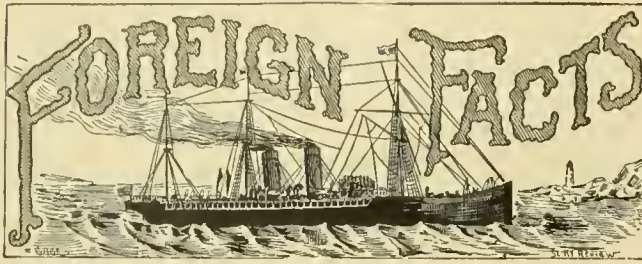

SERAJERVO, Austria, is to run an electric light and railway plant on the municipal plan.

NIJNINOVGOROD, the great Russian market town, is to have an electric railway on the overhead plan.

CLONTARF, Ireland, is to have an electric railway, and the Dublin tramways apply for electric rights on the Hill of Howth line.

ULM, Germany, will soon be riding by electricity. The Schuckerts, of Nuremberg, have received a fifty-year franchise on a percentage basis.

The Brazilian Street Railway Company finds in spite of war and hard times that traffic is on the increase, amounting to £42,560 against £38,360 in 1892.

An interesting feature of the Lyons, France, exhibition is an electric tramway on the alternating current system, put down by the celebrated Creusot Works.

HANNAN & Co., are about to establish a permanent sample exhibition at Johannesburg, South Africa. An efficient staff will be organized to exhibit and care for machinery of all kinds.

A NEW electric railway is now building between Lyons and Oulins, France. Thomson-Houston generators are in use. The old rolling stock of the company is being refitted for overhead trolley work.

PNEUMATIC tires for omnibusses are coming into vogue in England. McLellan & Co., of Glasgow, are making extended experiments on the subject. The brake is applied to the nave of the wheel when the pneumatic tires are used. Why not make it an air brake, brethren?

THE management of the Grand Berlin Horse Tramway Company, of Berlin, has erected an accumulator station in Waldenser and Wicief streets, and will experimentally work a line on the accumulator system from Werftstrasse (Moabit) to Hansaplatz, Luzowplatz, and Potsdamerstrasse.

THE Allgemeine Electricitats Gesellschaft, Berlin, Germany, has decided to appoint selling agents for its goods in the United States. New York, Chicago, Cincinnati, Atlanta, San Francisco, Boston, Philadelphia, St. Paul, Washington, Denver and other cities will be so

honored, and electrical firms wishing to handle these goods are requested to forward offers to the main office, 22 Schiffbauerdamm, N. W., Berlin.

GERMANY has more electric railways under construction than any other European country. There is no opposition to the trolley among these most scientific people and electrical industry will see great commercial progress before the end of the century. The English electrical papers bewail the conservatism of their country and are making a gallant fight for the more extended use of the trolley. France follows Germany in this particular, and Russia is waking up wonderfully upon the subject.

AN electric locomotive is in use at the Globe Machine Works, of Castleton, England, for shunting freight cars on the works' siding. The raw goods are backed into the siding by the railway engines, and are taken wherever required by the electric locomotive, worked on the overhead wire system. The packing department is provided with an electrical crane for hoisting the machinery either into railway trucks or on the wagons. The energy is generated by a dynamo in the main engine room, driven from the works' engine, which is of the horizontal tandem compound type.

#### The Big Four Route Has the Best Terminal Facilities at Chicago.

All trains enter Chicago on the Illinois Central tracks along six miles of the Lake Front, through the most picturesque portion of the city, and land passengers in the magnificent new Central Station on Twelfth street and Lake Front. This station is convenient to the Auditorium, Richelieu, Victoria and Leland Hotels, and within two blocks of the State and Wabash street cable lines and the South Side Elevated Railway. Convenient stops are also made at Hyde Park, Thirty-ninth street and Twenty-second street stations.

Magnificent vestibuled trains, parlor cars, Wagner sleeping cars, private compartment buffet sleeping cars and superb dining cars. No transfer across Cincinnati to make connections.

Your ticket should read via the Big Four route to enjoy these privileges. E. O. McCormick, Passenger Traffic Manager; D. B. Martin, General Passenger and Ticket Agent, Big Four Route, Cincinnati, O.

THE New Haven Car Register Company, of New Haven, Conn., has equipped the Chestnut and Walnut street lines of the Philadelphia Traction Company with the New Haven register. The machines were especially made with large faces adapted to the cars in which they are used. The New Haven is an elegant, durable and reliable piece of mechanism, and its popularity is a just reward for its quality and appearance. The manufacturers report a lively demand for and many enquiries after the device. In addition to the elegant appearance of the New Haven register, its positive action, safety and continuity of registration, and its strong construction, make it a most desirable and efficient device.

**THE HILL AUTOMATIC RHEOSTAT SWITCH.**

The W. S. Hill Electric Company has placed on the market a combination switch and rheostat that prevents

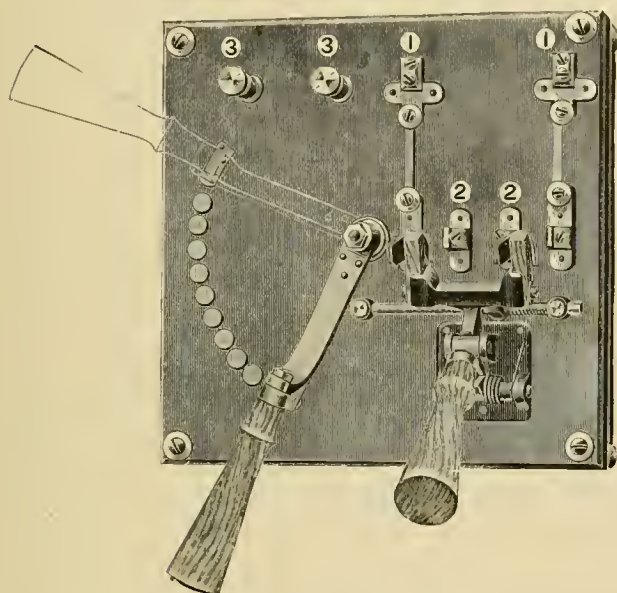

the current from being turned through a stationary motor unless all the resistance is in circuit. This accident is liable to happen when there is a switch separate from the rheostat. By combining the two with an interlocking device, safety is secured, and at the same time the price is less than for the rheostat and switch separate.

**MEETING OF THE NORTHWESTERN ELECTRICAL ASSOCIATION.**

The summer meeting of the Northwestern Electrical Association will be held in St. Paul, July 18, 19 and 20. There is an excellent promise of a large meeting. At the last meeting held in Milwaukee, 150 were present, and a larger number is expected at St. Paul. Representatives from all surrounding states have written that they will be present. An excellent programme has been prepared and the best expert electrical talent of the United States has been secured to address the convention. Current will be furnished to illustrate lectures as well as to accommodate exhibitors. Manufacturers and supply houses will be accorded every courtesy by the Association. Henry C. Thom, of Madison, Wis., is secretary.

A. B. BLACKBURN, M. I. C. E., has been appointed to succeed Thomas Parker as chief engineer of the Electric Construction Corporation, of Wolverhampton, England.

THE Bernese Oberland Railway, of Switzerland, is said to be about to substitute electricity for steam. The contract is a tremendous one, as ten trains are usually simultaneously on the tracks.

**PECKHAM'S AUTOMATIC LIFE AND WHEEL GUARD.**

It is to be expected that when the Peckham Motor Truck & Wheel Company attempts anything the attempt is successful. So thorough and careful a company can not afford to put upon the market anything but the best and most reliable devices.

The new Peckham automatic life and wheel guard, illustrated herewith, in connection with the improved extra long extension truck, combines simplicity, lightness and strength with safety and positive action. The guard is constructed of one inch wrought pipe, carrying a wire screen. It is five feet eight inches long and thirty inches wide, and attached to the guard plank by two cast iron brackets, in which are two pockets for spiral springs, one of which allows an upward motion in case of contact with an immovable object. The rear extension is bolted to the truck truss bar and provided with three holes, so that easy adjustment may be made to carry it at any desired height above the track. The screen is inclined at a sufficient angle, so that when a moveable object is struck, the spring allows the screen to drop to the track. As the device is centrally suspended by the special

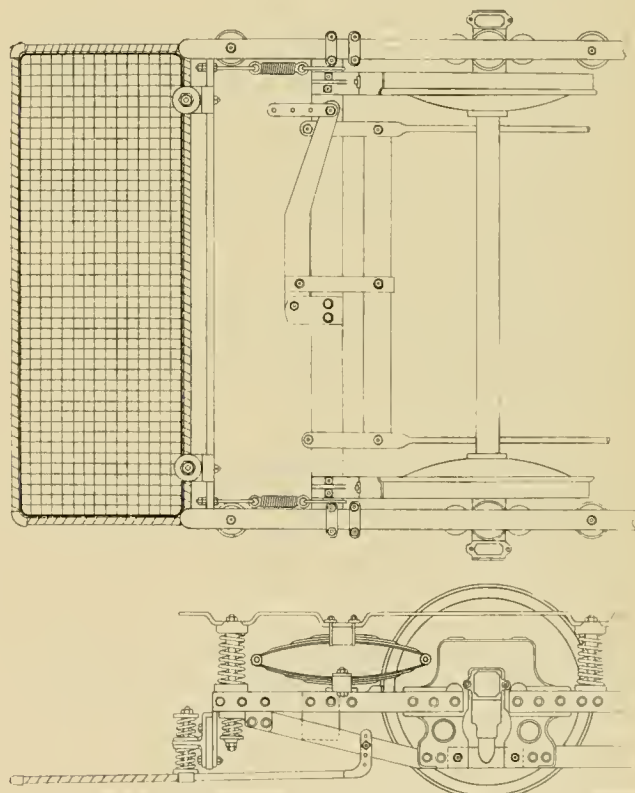

PLAN AND END ELEVATION.

spring, its tendency is downward when any moveable object is struck. The guard is designed expressly for the Peckham cantilever extension truck so well known to the trade.

ALEX. H. LEWIS, well-known to the electrical trade, has taken the Cincinnati agency of the Abendroth & Root boiler.

## HALF FARES.

Interesting Bits of Information from All Parts of the Country,  
Boiled Down for Busy Readers.

THE Columbia & Donegal Electric Railway was formally transferred to the Pennsylvania Traction Company, Senator Patterson's system, July 1.

THE Chevy Chase resort, near Washington, D. C., has been opened for the season. Boating, band concerts and an electric fountain are the attractions.

THE Bangkok, Siam, tramways use the sawdust from teak wood saw-mills for fuel. The tramways have done well financially during the first year of operation.

OUT of the thirteen street railway patents issued on June 27, seven were for fenders. Our statistical editor says that if this record can be kept up it will make 364 per year.

A BOSTON ex-councilman has a \$10,000,000 elevated railway scheme to perpetrate on the long-suffering city of baked beans. His little bill will be put before the legislature.

MOODY MERRILL, formerly president of the Highland Street Railway Company, Boston, who left Boston as a fugitive from justice, announces his marriage to a Mexican heiress.

NEWBURG, N. Y., has an electric street railway now in operation. It was opened for traffic June 9, the first car carrying a distinguished party of street railway men and city officials.

THE Nilgiri Railway, of India, has twelve miles of Abt rack rail on grades as steep as 8 per cent. It uses wooden ties, and is the only Abt rack in the world to do so except the Pike's Peak Railway.

THE inventor of an electrical appliance recently patented, assigned eighty-three one hundred and twenty-eighths of his patent to four other parties. What a time there will be dividing up the profits!

IT is proposed to build an electric tramway between Champel and Petit-Saconnex, via Geneva, Switzerland. A line is already building between Langenthal and Huttwyl. Siemens are the contractors.

AN ELEVATED JOKE.—Josh Hayseed—I put two tickets in the box. What are you going to do about it? Ticket Chopper—Well, as it isn't a ballot box, we'll let you off this time with a reprimand.—Texas Siftings.

PRESIDENT SHEPHERD, of the Cincinnati, Covington & Newport Street Railway, says that the report of a contract for fifty cars from two different car companies is incorrect, and adds that Brownell cars are used exclusively.

AS VIEWED from Boston, the Home Journal says: "According to a New York ruling every fourth street car must be closed. But who, in these rushing days, will let three go by in order to see whether the company lives up to the law?"

THE first summer traffic of the Brooklyn electric line augurs well for the season. On the second Sunday in June 500,000 people were carried to the various pleasure resorts, or more than five times the number carried on the corresponding day last year.

THE Bellwood and the Gaysport branches of the Altoona & Logan Valley Electric Railway, of Altoona, Pa., were opened for traffic June 28. The company now has 27 miles of track, two power plants, 63 cars, and the investment is rated at \$1,000,000.

An automatic horse-feeder is the invention of a Missouri genius. It depends on gravity for the dropping of feed into the bin and upon clock work for its regulation. Some bright street car mule will learn to "turn on" the clock before it has been in a street car stable a week.

GEORGE CUTTER, of the Rookery, Chicago, was down east on a business trip recently and tells the following as a true story: "Boston street car conductor—How old are you, my little girl? Little girl—If the corporation doesn't object I'd rather pay full fare and keep my own statistics."

W. T. ADAMS is made temporary receiver of the Chattanooga Electric Railway Company. Mr. Adams is president of the company and but recently elected. The road was in bad shape financially when he assumed charge, but a combination of circumstances necessitated this last movement.

THE Second Avenue Traction Company, of Pittsburg, has contracted with the Russell Engine Company, of Massillon, O., through F. G. Borden, the Pittsburg agent, for a cross compound condensing engine of 1,800-horse-power. The engine will be installed at the new power house to be built at Glenwood.

ONE Miss Bessie Off, while riding her bicycle recently at Asbury Park, N. J., carelessly ran before a motor car. She sustained a compound fracture of the right arm and two fractures of the leg below the knee. The plucky girl, while on her way home, sent word to the company that it was her own fault, exonerating the motorman.

A BOSTON paper tells of an "idiot" who suggests combination cars, half open and half closed, and pronounces the scheme an unheard of lunacy. Exactly such cars are, however, in use on both the West and North Side cable lines in Chicago, and on several electric roads on the Pacific coast, and have been in operation several years.

ALL the street car mules in Nebraska City, Nebraska, were destroyed by fire not long ago, with one exception. This latter animal, although badly burned, will live. This particular mule seems to bear a charmed life. A few years ago the barn was struck by lightning and every four footed animal, except the above mentioned, was killed. May he live long and be pensioned.

AN old lady of Middletown, O., came into the office of the new Middletown & Goshen street railway recently and bought a dollar's worth of tickets, saying: "I have had a few rides on the electric cars and I find that I have had more relief from my rheumatism than I have received in the past three years. I want a book and I'll ride as often as I can find time to do so. It's cheaper than medicine."

B. S. COLER, of the West Side Street Railway, Kansas City, Kan., holds an annual reception to newspaper men and city officials at Brown's Park. Refreshments are served and the street railway lines placed at the disposal of the guests. This year's reception was held July 2. These occasions have always been of the most pleasant nature and result in a friendly feeling on the part of all so entertained.

ON the morning of June 21, a crowded interurban car, plying between Minneapolis and St. Paul, jumped the track on the Twenty-first avenue bridge and dashed onto the railing with terrific force. The rail broke and fell into the river, but the car stopped and swayed on the edge. The conductor stood at the door, which was just over the stream, and held the passengers back, thus preventing them from crowding each other into the river, nearly 100 feet below.

IT is estimated that 2,000,000 head of half-breed horses range the plains of Nevada, Washington, Oregon, Idaho, and Nebraska. They are useless except as food and fertilizers, and the agricultural papers lay the blame of all of it upon the electric railway. Verily, "Othello's occupation's gone. Why not give these horses to the Coxeyites and save railroad fare and provender. When the mounted commonwealers reach Washington they could eat their steeds and save the poor fund.

BUILDING a street railway line in Passaic, N. J., is not all one blissful dream. It is a battle, a hand-to-hand conflict, in fact, a fight. Not long ago a gang of men were set to digging holes for the side poles, when not only the male inhabitants of the vicinity but the females rushed forth, and while the latter held the workmen's shovels the former filled up the holes. One old woman knocked down the foreman of the gang, and the police had to interfere to protect the lives of the unfortunate pole-setters.

A LITTLE Keokuk, Ia., girl was sent out one day to make some small purchases. Five cents were left in the form of a nickel wherewith to pay street car fare home. As she was picking up her packages, she inhaled sud-

denly and swallowed the nickel. She gasped for a minute and then said, "Gracious! I've swallowed my nickel, and I'll have to walk home." When asked if she felt uncomfortable, she said, "It hurts here," pointing to her heart. Suddenly gathering her packages, she started home on the run. No wonder some people have indigestion.

WE are in receipt of a general letter issued by the J. H. & D. Lake Company, of Massillon, O., and signed by the president of the company, stating that the concern is in the sheriff's hands, at the instance of the Board of Trade and the Merchants' National and Union National Banks of Massillon, demanding immediate settlement of loans. Mr. Lake also says that by the failure of B. H. Parkhurst, the company's endorser, the above-named creditors refused further promised assistance. W. F. Ricks, president of the Massillon Board of Trade has the matter now in hand.

HAVE you one? According to the Electrical Review, London, a firm of London electrical contractors has had a very amusing enquiry regarding a machine required for the Indian market. An Indian customer wants to know the price of a machine which "(1) gives electric shocks and sends out sparks; (2) is a magic lantern of sorts; (3) can make any noise desired, and can ventriloquise. The name of the instrument has been forgotten." It is evident that somewhat exaggerated ideas are abroad in India as to the wonders of electricity, or perhaps it is pneumatic-storage battery arrangement with the inventor connected with it.

THE members of the Knox Church, at Hamilton, Ont., in prayer-meeting assembled, passed the following resolution: "The congregation of Knox Church, this city, hereby earnestly raises its protest against the flagrant and, in its judgment, wickedly-unnecessary disturbing of public worship on the Lord's day by the running of the Hamilton street cars. The pretence that the said cars are run for the accommodation of the Lord's people is the veriest cant, the sheerest hypocrisy of this mammon-pursuing age of the world. They are run for gold alone.—Mungo Fraser, unanimously endorsed by the prayer-meeting."

WHEN that organ of othersidedness, the New York Recorder, isn't blessing street railways with the left hand it is saying something nice like this: "The open street car is a great blessing. It is the poor man's carriage, the sick baby's health resort in hot weather. Ninety-nine people out of a hundred prefer the open car, night or day, but a few bloodless busybodies, who have plenty of time to growl, make more noise than the great majority, City people never get too much open air, anyhow. If a person catches cold on an open horse car even at night, there's probably something the matter with his nose or lungs which a doctor might remedy." It all comes of the open car schedule mentioned last month, which the Recorder disagrees with. Why? Who knows?

## ACCUMULATORS IN CENTRAL STATION RAILWAY WORK IN SWITZERLAND.

Switzerland is justly regarded as the center of the electrical industry in Europe. This is particularly the case in the electric traction field, and to Switzerland we look for the latest developments of long distance transmission. In a series of articles on the development of electrical science in this country, the "Electrical World" of June 30, 1894, gives an extended account of the Zurich-Hirslanden Electric Railway. The line runs from the center of Zurich to the suburb of Hirslanden, over a series of grades ranging from 0.4 per cent to 6.3 per cent; with a total length of about three miles. The gauge is 39 inches and when all are commissioned 18 cars will be operated. The power equipment consists of two 100-horse power engines belted direct to Oerlikon generators, and one 45-horse power engine. The two large generators have a capacity of 66 kilowatts. Under ordinary

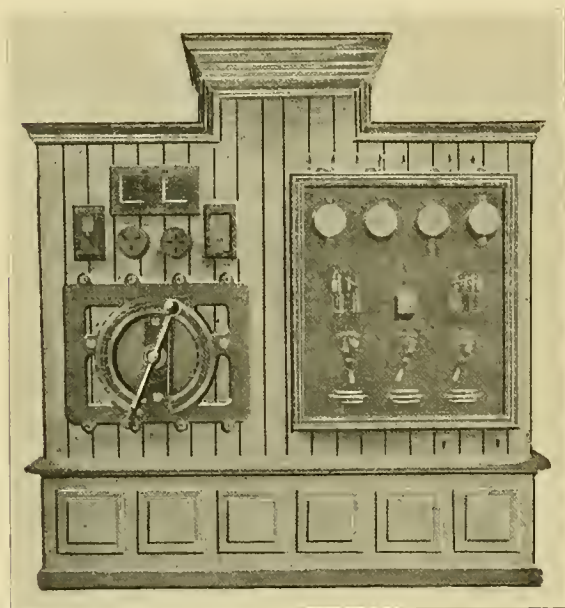

THE SPECIAL SWITCHBOARD.

conditions at 450 r. p. m., the output is 120 amperes at 550 volts. The smaller engine is coupled direct to an auxiliary generator for charging the "extra" battery cells. To the accumulator practice of this station this story particularly appertains. At the rear of the power house is another building in which are placed 300 Tudor type secondary battery cells, to equalize the station load and permit of shutting down for short intervals in case of accident to the generating machinery. The line is a small one, but in plants of this size the storage batteries offer the greatest saving and convenience, added to which is the economy of power in ascending the constant succession of grades when greater power is necessary.

Of the 300 cells, connected in series, 240 constitute the battery proper and are always in parallel circuit to the

generator; the remaining 60 cells are used for regulating purposes and through a circular switch are put in, out of the line circuit as required. Each cell has a normal capacity of 245 ampere hours with an 80 ampere discharge, although 160 amperes can be taken momentarily without damage. The battery as a whole is rated as capable of giving 120 amperes at 550 volts and is estimated as sufficient to run the line with nine cars for from 1½ to 2 hours, independently of the generators. The 60 additional cells having such an important function are carefully conserved. For at least an hour each day when the least load is on the line the small generator charges them independently of the rest of the battery. As a rule the extra cells are found to be "run down" at the end of the day. It is found that the average current output from the station with nine cars on the track is 90 amperes, although the momentary fluctuation may vary from 0 to 200 amperes. When the cars are drawing no current the whole of the current output from the generator passes into the battery for storage, while in the latter condition the generator supplies the line with 120 amperes and the battery makes up the deficiency of 80 amperes. Load variations may cause variation in the speed of the engine amounting to two or three per cent, and the question as to the source of supply at a certain moment of overload depends upon whether the cell regulation or that of the generator responds the quicker. It is the function of the cells to take up the highest peaks of the load, so that an economy can be effected in the size and first cost of engines and generators. The use of the battery makes it possible to run on half the size of the plant otherwise necessary. Only one generator need run continuously.

A special switchboard, in addition to the ordinary railway board, controls the battery. On this board are arranged the "high" and "low" voltage relays, ammeters and discharging switches for the battery, which forms the direct source of power to the line. The most conspicuous apparatus is the circular switch which cuts in and out the cells to suit the variations of the line voltage. In this "cell regulator switch" the contact arm actuated from behind by two selenoid magnets acting by reverse pawls upon toothed wheels, swings around the contact plates in either direction with continued and unvarying accuracy. A "minimum cut out" disconnects the generators whenever the charging current from the generators falls below 10 amperes. All the regulation on the board is automatic.

## A PROMISING OPPORTUNITY.

What seems to be a very promising interurban enterprise is being organized to connect several other towns from Lancaster, Ohio, to the Buckeye Lake Park. A. Bauman, the manager of the Lancaster Electric road, is promoting the affair, and a liberal amount of local capital is promised to put it through. Some outside money is necessary to carry out the plan. Inquiries may be sent to A. Bauman, manager, Lancaster, Ohio.

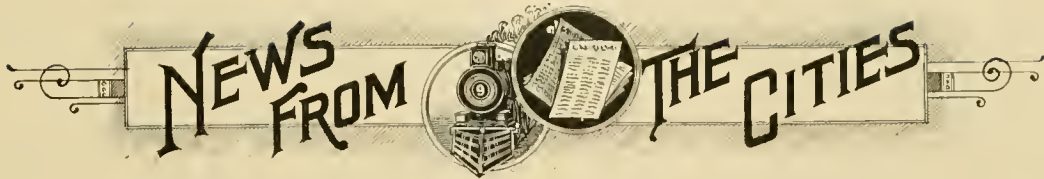

**Alabama.**

OPELIKA, ALA.—Opelika & Auburn Electric Railway elects M. E. Gray, Columbus, Ga., president; A. H. Slaughter, treasurer, and C. I. Daughtry, secretary. Payment of first installment on stock called for within thirty days.

**Arkansas.**

HELENA, ARK.—The plant and franchise of the Helena Electric Light & Power Company have been sold at receiver's sale to the Helena Gas Company. New power house will be built.

**California.**

SAN FRANCISCO, CAL.—Adolph Sutro applies to supervisors for franchise to the Cliff House.

SAN FRANCISCO, CAL.—W. F. Rudolph succeeds S. B. McLenagan, as superintendent of the Oakland Central avenue road.

SAN FRANCISCO, CAL.—The Presidio & Ferries Railroad Company applies for additional franchises, including use of electricity.

BERKLEY, CAL.—W. E. Sell, J. G. Gardner and J. R. Little have petitioned the trustees for franchise over several routes in this suburb.

SAN DIEGO, CAL.—The Security Company, which acquired the old Park Belt Line, has secured a franchise through the city and will begin work soon.

SAN FRANCISCO, CAL.—Sanford Bennett, the receiver of the San Francisco & San Mateo, wants permission to mortgage the property for \$100,000, which amount he says is necessary for immediate improvements.

SAN FRANCISCO, CAL.—Three years ago a franchise was obtained for the Market Street Cable Railway for a line on Page and Frederick streets. A conduit was placed but nothing else done. Franchise has now expired and an attempt will be made to nullify the rights of the company.

**Canada**

BELLEVILLE, ONT.—S. A. Lazier & Sons, of this city, ask for franchise for street railway and light plant.

MONTREAL, QUE.—The Standard Light & Power Company announce that they will begin work immediately on an electric railway to Lachine via the Upper Lachine road.

HAMILTON, ONT.—John Patterson, projector of the Hamilton Radial Railway, says that he has succeeded in getting several New York capitalists interested in the enterprise.

ST. JOHN, N. B.—The St. John Electric Railway, elects directors: Sir Wm. Van Horn and James Ross, Montreal, and J. J. Tucker, H. P. Timmerman and H. H. McLean, St. John. Van Horn was made president.

OSHAWA, ONT.—The plans of the electric railway which Capt. Carter, of Deseronto, Ont., proposes to construct here, have been accepted by the city council. The road will be built in three sections and will receive a cash bonus of \$75,000.

HULL, QUE.—The city council has granted a charter to Mr. Viau's local company to run an electric railway in Hull. The charter is for thirty-five years, the work not to start before two years from now; \$15,000 must be spent in the first year after starting, and \$5,000 a year for the next ten years. In twenty years the corporation can buy the whole outfit by arbitration.

**Chicago.**

CHICAGO.—The Cicero & Proviso asks for extensions in the village of Harlem.

CHICAGO.—Permit to Lake Street L to build bridge across the river for North Side branch has been granted.

CHICAGO.—Organized: Columbia Motor Company, Chicago; capital stock, \$1,000,000; incorporators, Walter E. Sparks, Richard W. Robinson and John C. Wilson.

CHICAGO.—The Illinois Supreme Court decides that street railway companies must provide fenders around the wheels of their cars to protect the public from injury.

CHICAGO.—A franchise is introduced in the city council by Alderman Powers, giving the Central Rapid Transit Company right to build a "storage battery, caloric or hydraulic" street railway on the South West Side.

CHICAGO.—A. E. Lancaster, secretary of the Chicago syndicate controlling the Cass Avenue lines, of St. Louis, says that the J. N. Campbell scheme, to consolidate Saint Louis Street Railways, is so far simply a scheme of Mr. Campbell, who is a bright and successful promoter. The syndicate has not been approached.

CHICAGO.—Organized; Schuttler Ratchet Drill Company, at Chicago; capital stock, \$25,000; incorporators, Joseph W. Hiner, Woodland I. Todd, and Henry E. Byers.

CHICAGO.—Council committee recommends passage of the Northern Electric Railway franchise ordinance introduced May 24. It provides for double track electric railway on West Forty-seventh street from Lake to Thomas streets, and in that neighborhood.

The committee also recommended the passage of the ordinance of the Cicero and Proviso Railroad Company for a double track road on west Forty-eighth street from West Lake street to West Chicago avenue; on West Chicago avenue to West Fifty-second street with the right to connect with the other lines of the road.

**Colorado.**

DENVER, COL.—Supreme Court decides that Denver Tramway Company's original franchises for cable and electric lines are valid.

**Connecticut.**

WALLINGFORD, CONN.—Meriden Electric Railway Company has decided on extensions.

BRIDGEPORT, CONN.—The Bridgeport Traction Company has the following officers: President, Col. N. H. Heft, of Bridgeport; vice-president, Elias Ward, of Newark; treasurer, Wm. Sheerer, of Newark; secretary, Thos. L. Watson, of Bridgeport.

HARTFORD, CONN.—The Hartford, Manchester & Rockville Tramway Company is organized as follows: President, M. S. Chapman; secretary and treasurer, H. J. Wickham; directors, E. Stevens, Henry and William H. Prescott, of Rockville; Elisha Morgan and R. W. Day, of Springfield; G. Henry Whitcomb, of Worcester, and E. C. Hilliard and M. S. Chapman, of Manchester. Company has plenty of money and will begin work immediately.

**District of Columbia.**

WASHINGTON, D. C.—The Columbia railroad has made application to the commissioners to cable part of its lines.

WASHINGTON, D. C.—Ex-Representative Hemphill, of South Carolina, and Washington capitalists, have a bill before congress to incorporate an electric elevated between Washington and New York.

### Florida.

TAMPA, FLA.—E. S. Douglass, president of the Consumers' Electric Light & Street Railway Company has bought the Tampa Street Railway & Power Company, and will consolidate it with his own company. He will improve the service.

KEY WEST, FLA.—The Key West Gas & Electric Company has increased its capital stock from \$75,000 to \$250,000. The change will allow enlargement of plant and building of a street railway. Some equipment is already bought.

ST. AUGUSTINE, FLA.—The St. Augustine Railway & Steamboat Company is preparing to build its line from St. Augustine to North Beach. There is about two and a half miles of old embankment to repair and a half mile of new grading, the remaining distance being on the streets of the city. Some new piling and other trestle work is required. Electric power will probably be used. Contractors and others supplying equipment for street railways may meet by appointment, or address, until July 15, Chas. Sperry, superintendent, 12 West Thirty-first street, New York City.

### Georgia.

AUGUSTA, GA.—Superintendent Thomas A. Roberts died, June 27, at the age of 30. He is succeeded by W. E. Moore, electrician of the company.

DONALSONVILLE, DECATUR COUNTY, GA.—The Donalson Lumber Company wants 5 miles of 30-pound relaying rail with bolts, spikes and fish plates, for tram line.

### Illinois.

BELLEVILLE, ILL.—City council grants Belleville City Street Railway company right of entering the city on Seventh street.

AURORA, ILL.—The Street Railway Company will convert the Scharschburg farm into a summer resort. It contains eighty acres. Attractions wanted.

WAUKEGAN, ILL.—Organized: Bluff City Electric Street Railway Company, Waukegan; capital stock, \$200,000; incorporators, Dewitt L. Jones, S. D. Talcott and Charles Whitney.

### Indiana.

TERRA HAUTE, IND.—The street railway company is arranging to burn oil fuel.

INDIANAPOLIS, IND.—Elwood Electric Street Railway will issue \$50,000 in bonds to construct line from Elwood to Frankton. Chicago parties will buy issue.

INDIANAPOLIS, IND.—Indianapolis & Broad Ripple Rapid Transit Company having been refused right of way by county commissioners, has been getting private right by purchase.

WABASH, IND.—The Wabash Electric Railway Company appoints A. J. Ross, A. H. Plummer and Nathan Meyer as committee to confer with supply men and manufacturers in regard to cost of building the line.

HAMMOND, IND.—The Hammond, Whiting & East Chicago Electric Railway Company elects: President, Charles F. Griffin; vice-president, A. M. Kaufman; secretary, treasurer, general manager, A. M. Turner.

FT. WAYNE, IND.—Ft. Wayne Electric Corporation is organized to liquidate the affairs of the Ft. Wayne Electric Company. Its capital is \$1,500,000, and it will absorb all existing contracts and business of the present company.

ELKHART, IND.—Since the transfer of the Elkhart Street Railway to the Indiana Electric Railway Company, Chicago, it is understood that the line will be greatly improved and extended. New lines will be built and other improvements made.

INDIANAPOLIS, IND.—J. C. Shaffer has been awarded \$25,000 as the last payment of the \$100,000 commission for the sale of the Citizens' Street Railway to the Sellers-McKee-Verner syndicate. The case attracted considerable attention.

TERRA HAUTE, IND.—Incorporated: The Terra Haute Electric Railway Company. Capital stock, \$500,000. The directors are: Paris P. Thomas, John G. McNutt and M. F. Burke. Russell Harrison is a principal stockholder in the concern.

TERRA HAUTE, IND.—The Terra Haute Electric Railway Company has had the franchise of the Terra Haute Street Railway transferred to it. The new company was organized with the object of increasing the capital stock of the road and making extensions and improvements.

### Iowa.

SIoux CITY, IA.—Sioux City Traction Company is about to buy extra trailers for holiday and Sunday use.

ATLANTIC, IA.—A prominent business man of Atlantic is said to be organizing a street railway company for this town.

DES MOINES, IA.—B. F. Clayton, A. A. McGarry and E. W. Hartman are at work on a scheme to build an electric road from here to Indianola.

COUNCIL BLUFFS, IA.—City council grants franchise to the Council Bluffs & Lake Manawa Electric Railway. Electric lights required every two blocks within the city limits.

FT. DODGE, IA.—S. T. Meservey has received a twenty-five-year franchise for an electric railway and lighting plant from the city council.

SIoux CITY, IA.—Receiver Mohler, of the Sioux City Cable Railway, has tendered his resignation and recommends that the property be turned over to its owners, as all but \$14,000 of the liabilities have been wiped out and there is \$19,000 cash in hand.

COUNCIL BLUFFS, IA.—Council Bluffs & Lake Manawa Electric Railway is incorporated at \$50,000, by Jeff W. Bedford, L. H. Kent, J. P. Finley, H. B. Coryell, D. D. Gregory, E. S. Rood, Isador Gluck, C. A. Starr, and C. W. Reed. All but the two last named will constitute the first board of directors.

SIoux CITY, IA.—Receiver Mohler, of the Sioux City Cable Railway, says that the line has earned \$10 a day net since equipping electrically. He has issued \$63,110 in receiver's certificates, all of which have been taken up by the consolidated capitalists. He requests that the receiver be discharged and the property turned over to the consolidation.

Receiver A. M. Jackson, of the Sioux City Rapid Transit Company, reports net loss during his term, while steam was used as traction power, of \$502, and a net profit for the nine months of electric traction of \$152.

### Kansas.

LEAVENWORTH, KAN.—The receiver's sale of the street railway has been confirmed.

ARGENTINE, KAN.—Ernest L. Enggren et al. apply for electric railway franchise in this place.

KANSAS CITY, KAN.—The incorporators of the Kansas City Electric Street Railway Company are: Ben J. Jones, New York; F. B. Wilcox, Kansas City, Mo.; Lewis Humane, West Chester Pa.; J. H. Parrott, R. A. Kope, P. F. Spickles, Kansas City, Kan.

LEAVENWORTH, KAN.—The Leavenworth Electric Railway has been sold at receiver's sale for \$80,000. After the purchase a new company was organized as follows: President, Newman Erb, of New York; vice-president, Herbert N. Smith, of Boston; secretary and treasurer, J. P. Edrington, of Denver, Col. The new directory is composed of the following named: Newman Erb, J. P. Edrington, Herbert N. Smith, M. Summerfield, W. D. Bethel, of Memphis, Louis M. Erb and E. E., Godlove, of this city.

### Louisiana.

NEW ORLEANS, LA.—The Carrollton Railway will establish a resort at the head of St. Charles avenue and build line thereto.

NEW ORLEANS, LA.—Orleans Railway Company directors will petition council for electric rights in down town district. Peter Congot is president, and L. N. Petitpain is secretary. The building of the new line will be given to the lowest bidder.



## Maine.

**BATH, ME**—The Bath Street Railway has let a contract to the Worcester Construction Company to improve the entire line.

## Maryland.

**CRISFIELD, MD.**—A company is being formed to connect Crisfield, Mariners, Asbury and Abes Hole with an electric road.

**BALTIMORE, MD.**—Baltimore and Harford, turnpike contract to grant the City Passenger Railway right for electric line; consideration, \$6,000.

**BALTIMORE, MD.**—It is said that the purchasers of the Maryland end of the Baltimore & Lehigh Railroad are contemplating changing the operation of the line from steam to electricity.

**BALTIMORE, MD.**—J. W. Kohlbe, master mechanic of the City & Suburban, has resigned.

**BALTIMORE, MD.**—Mortgage for the Pimlico & Pikesville Railway Company for \$350,000 is recorded, also one of the same amount for the Baltimore & Curtis Bay Railway Company. Both are issued by the Baltimore Traction Company.

**BALTIMORE, MD.**—Managers of stock exchange recommend listing of \$2,500,000 stock of the City Passenger Railway Company. The earnings of the company are shown to have been, for 1891, \$835,400.43 gross, \$86,233.40 net; 1892, \$780,388.29 gross, \$85,712.54 net; 1893, \$794,450.24 gross, \$128,102.89 net. The company has 21.6 miles of cable and 23.4 miles of electric road completed.

## Massachusetts.

**LOWELL, MASS.**—The South Side Street Railway (new company) is seeking franchises on certain streets.

**BROCKTON, MASS.**—The Brockton Street Railway has been ordered to use girder rails on its lines, which are soon to be relayed.

## Michigan.

**ADRIAN, MICH.**—It is announced that the Adrian Electric Belt Railway has been sold to Philadelphia capitalists.

**BATTLE CREEK, MICH.**—F. J. Willson has declared that if properly treated he will rebuild and rehabilitate the street railway system for the town.

**SAGINAW, MICH.**—The Union Street Railway is to be known as the Riverside Park Railway and an extension is ordered to be built immediately.

**ANN ARBOR, MICH.**—Dr. W. B. Smith signs an agreement, which, if accepted by bondholders, will result in resumption of traffic on the street railway.

**TRAVERSE CITY, MICH.**—The Grand Traverse Herald is authority for the rumor of an electric railway between Traverse City and Old Mission.

**ADRIAN, MICH.**—The street railway has shut down and will probably not resume until it changes hands. Cars are in bad repair and electric equipment in poor condition.

**SAGINAW, MICH.**—Isaac Bearinger, capitalist, of this place, wants to build an electric railway from Saginaw to Bay City. The line will be 16 miles long and touch other places.

**SAGINAW, MICH.**—The differences between the Union Street Railway and the city have been amicably settled, and the paving and extension of lines will now proceed. The entire system will be rehabilitated during the year.

## Minnesota.

**WINONA, MINN.**—Winona General Electric Company has made satisfactory arrangements for extending its lines. A. H. Hill is made general manager.

**MINNEAPOLIS, MINN.**—The Twin Cities Rapid Transit Company will extend its line to Fort Snelling. The government has heretofore withheld right of way but now grants it.

**STILLWATER, MINN.**—Stillwater Street Railway elects: President, Allan Curtis, of Boston; vice-president, E. P. Motley, of Boston; treasurer, George E. Warring, of Boston; secretary, J. C. Nethaway.

**WINONA, MINN.**—George E. Duffie, of the Winona General Electric Company, in conference with General Manager Hill, says that the West Fifth Street route will be extended and considerable other improvement made in the system.

## Missouri.

**KANSAS CITY, MO.**—The cable consolidation case will not be heard until the October term of court.

**KANSAS CITY, MO.**—Walter Gillam has been made superintendent of the L system. He is succeeded on the Armourdale line by Thomas Grover.

**SEDALIA, MO.**—F. E. Hoffman and Dr. A. V. Small are at work to make a summer resort out of McAllister Springs and build a street railway line thereto.

**JOPLIN, MO.**—Col. H. H. Gregg and S. C. Henderson were in St. Louis recently making arrangements for the extension of the Joplin Electric Railway to Baxter Springs.

**JOPLIN, MO.**—The Interurban to Galena is regarded as certain. It will be built by Joplin capital, and the new company will absorb the Joplin Electric Railway & Motor Company.

**JOPLIN, MO.**—The Southwestern Electric Light & Water Power Company will erect a big light and power plant, including repair and manufacturing shops, for a general electrical business. An electric railway to Galena, Kan., is also proposed.

**ST. LOUIS, MO.**—James Campbell has secured the Grand Avenue line for the Union Depot Company. The Grand avenue franchise is a valuable one and must be built on or before October 15. John Scullin is the new owner and will begin at once to make his arrangements.

**KANSAS CITY, MO.**—The Kansas City Consolidated will spend \$30,000 on enlarging the Woodland avenue power house and general improvements on the cable lines. The 2,000 horse-power Allis Corliss from Machinery Hall, at the World's Fair, has been purchased.

**KANSAS CITY, MO.**—Judge Slover declares the franchise of the East Fifth Street Railway Company forfeited on account of non-user.

The West Side Street Railway of Kansas City, Kansas, is preparing to ask for two franchises, one from Riverview to the Union Depot and another to connect with the Ninth Street Cable line.

**KANSAS CITY, MO.**—A car wheel and cable pulley factory, to be known as the Kansas City Car & Foundry Company, is chartered by W. N. McMillan, William McMillan, W. K. Bixby, Calvin Davis, W. D. McLeod, W. T. Woolsey, and S. M. Blewitt. The McMillans and Bixby are large holders in the Missouri Car Wheel Foundry, of St. Louis.

**ST. LOUIS, MO.**—The Grand Avenue Railway Company reorganizes under the Scullin management. The new board comprises John Scullin and his sons Fred and Harry, James Campbell and his cashier, W. F. Reed. Vice-President Alonzo C. Church and Attorney Thomas E. Ralston of the Wiggins Ferry Company; secretary, J. H. Roach of the Union Depot Line, George M. Black and John G. Kelly.

## Nebraska.

**NEBRASKA CITY, NEB.**—Barns and plant of the Nebraska Street Railway destroyed by fire. Eighteen horses lost.

**OMAHA, NEB.**—Lightning struck the Nineteenth street power house of the electric railway destroying a dynamo. Loss, \$1,500.

**FALLS CITY, NEB.**—F. C. Oakley, representing a company, asks for a street railway franchise here. Business men encourage the idea.

LINCOLN, NEB.—W. E. Shepard, late electrician of the Lincoln Street Railway Company, has gone to Long Island City, L. I., as electrician for the Steinway Street Railway.

### New Hampshire.

DOVER, N. H.—The Union Street Railway Company has been placed in the hands of a new receiver, Geo. E. Macomber, of Augusta, Me. He takes charge at once.

KEENE, N. H.—The Keene Electric Railway Company elects E. F. Lane, president; G. A. Litchfield, treasurer, and F. H. Whitcomb, clerk. Opinion expressed that local capital should build the line.

NASHUA, N. H.—The annual meeting of the stockholders of the Nashua Street Railway Company resulted in the election of the following directors: Arthur E. Denison, John A. Fisher, John D. Chandler, E. F. Chandler and John P. Goggin; treasurer, John D. Chandler; clerk, John P. Goggin. At a subsequent meeting of the directors the following organization was made: President, John A. Fisher; vice-president, John D. Chandler; secretary, John P. Goggin; general manager, John A. Fisher.

### New Jersey.

MORRISTOWN, N. J.—Aug. W. Cutler, attorney, represents citizens of Morristown, who wish to get a street railway franchise, paying percentage for use of streets.

NEWARK, N. J.—The North Jersey Traction Company elects J. K. Corbiere, president; H. M. Doremus, vice-president; William S. Johnson, secretary and treasurer; Halsey M. Barrett, counsel; James Owen, chief engineer. An executive committee composed of John L. Johnson, W. L. Johnson, W. J. Davis and J. K. Corbiere, the latter a member ex-officio, was appointed. The capital stock of the company is placed at \$5,000,000. The address of John L. Johnson is Prudential Building, Newark.

### New York.

JAMAICA, N. Y.—The Long Island Electric Railway has made application for a franchise here.

ITHACA, N. Y.—The Cayuga Lake Electric Railway has been leased to the Ithaca Street Railway.

MOUNT VERNON, N. Y.—John R. Conron has been made local manager of the Union Electric Railway Company.

NEW YORK CITY.—The General Electric Company has secured an attachment for \$500,000 against the Ft. Wayne Electric Company.

BUFFALO, N. Y.—The Crosstown Street Railway Company has secured a grant to connect its Main Street line with Hertel avenue.

GREENPOINT, L. I.—The Long Island Electric Railway has been granted permission to lay tracks on certain routes on a per centage basis.

NEW YORK CITY.—The Coney Island & Brooklyn Railroad Company has applied to the state commission for right to trolley a part of that system.

ILION, N. Y.—Mohawk & Iliion Street Railroad Company elects: President, C. W. Carpenter; secretary, H. D. Alexander; treasurer, R. M. Devendorf.

NEW YORK.—It is again rumored that the Manhattan L will adopt electricity. The management will, however, await the demonstration of the Metropolitan, of Chicago.

AUBURN, N. Y.—H. V. S. Lord, president of the Business Men's Association, is at work on a project to connect Auburn, Skaneateles and Port Byron with an electric railway.

NEW YORK CITY.—The Metropolitan Traction Company has applied for permission to cable Twenty-third street from Broadway to Lexington avenue and thence to Thirty-sixth street.

NEW YORK CITY.—Goodwin & Swift, electric and surface railway construction firm, promoters and bankers, at 66 Broadway, assign to Arthur E. Waldradt; liabilities about \$500,000.

NIAGARA FALLS, N. Y.—The Niagara Falls, Whirlpool & Northern Electric Railway is now assured. J. W. Hoffman & Co., Philadelphia, will build the line by August 1. Power will be rented.

NEW YORK, N. Y.—The Forty-second, Manhattanville & St. Nicholas Avenue Railroad has applied for permission to build a road on West Eighty-sixth street, between Eighth and Tenth avenues.

JOHNSTOWN, N. Y.—R. T. McKeever buys J. S. Burr's interest in the syndicate owning the road, and is elected director. There is a rumor that H. Walter Webb is again seeking to control the road.

GLEN FALLS, N. Y.—William Finnigan, once superintendent of the Albany street Railway Company, has become general manager of the Glen Falls, Sandy Hill and Ft. Edward Street Railway Company.

SYRACUSE, N. Y.—The court has authorized Receivers Mack and Rice, of the Syracuse Consolidated Street Railway, to issue receivers' certificates to the amount of \$5,000, for relaying the track on Delaware street.

WHITE PLAINS, N. Y.—S. L. H. Ward, E. C. Sniffens, Edward Phelps, S. Gainsboro and John Duffy, of this village, will apply for franchise to build an electric line from Elmsford to Mamaronek, through White Plains.

LEWISTON, N. Y.—The Lewiston & Youngstown Electric Railroad Company has elected the following officers: President, Hon. Elton T. Ransom; vice-president, W. A. Philpott; secretary, Dr. W. R. Campbell; treasurer, Dr. W. D. Hough.

BUFFALO, N. Y.—The Buffalo, Tonawanda & Sanborn Electric Railroad will begin operations Aug. 1. New officers of the road were elected yesterday. They are: President, L. F. W. Arend; vice-president, Louis T. Payne; treasurer, E. G. Reisterer; secretary, Lee R. Sanborn.

WATERTOWN, N. Y.—A certificate of consolidation of the Watertown Street Railway and the Watertown & Brownville Street Railway Company, forming the Watertown & Brownville Street Railway Company, with a capital of \$100,000, has been filed. The directors are Byron B. Taggart, Senator Joseph Mullin, Hiram F. Inglehart, E. S. Goodale and Samuel F. Buggale of Watertown, and John C. Thompson and Charles A. Starbuck, of New York City.

NEW YORK CITY.—A syndicate has been quietly getting right of way for a Long Island electric railway for some time past. Fourteen miles of right of way is now secured. There is a paid up capital, it is said, of \$600,000, with a million or more in reserve. A. R. Hart, of Brooklyn, is president of the company; Charles H. Mullen, of Mount Holly Springs, Pa., is vice-president; Clarence Wolf, of Philadelphia, treasurer J. C. Von Arx, secretary, and Jerry A. Wernberg, counsel.

### Ohio.

PAINESVILLE, O.—Painesville, Fairport & Richmond Street Railway increases stock from \$50,000 to \$150,000.

COLUMBUS, O.—Forrester & Co., Cleveland, are granted railway franchise on National road east of the city.

NORWALK, O.—The old board of directors of the Sandusky, Milan & Norwalk Street Railway is re-elected for the ensuing year.

ASHTABULA, O.—J. N. Stewart has begun suit for \$150,000 damages against the village for destruction of his street railway in 1890.

GALLIPOLIS, O.—H. R. Bradbury takes charge of the electric railway as receiver. He is authorized to spend \$2,000 in improvements.

CLEVELAND, O.—A twenty-five year franchise has been given to the Big Consolidated for South Brooklyn. Line will be double tracked.

CUYAHOGA FALLS, O.—It is not unlikely that the Akron & Cuyahoga Fall Rapid Transit Company will extend to Kent. Work will begin in the fall.

**AKRON, O.**—The Walsh-Babcock Street Railway Company gains franchise to Barberton. Work begins at once. Address E. L. Babcock, Cuyahoga Falls, O.

**CLEVELAND, O.**—The Cleveland & Elyria Street Railway Company is incorporated by B. F. Phinney, Jay Comstock, J. M. Gasser, H. D. Coffinberry and Dallas Beebe.

**DELAWARE, O.**—Delaware Electric Railway Company elect W. A. Hall, president; Hon. F. M. Marriott, secretary, and C. Riddle, treasurer. The line will be extended.

**COLUMBUS, O.**—W. E. Hoyer, W. T. Thorn, Captain Wm. Penny, et al., have been granted a 25-year franchise for an electric railway from Worthington to Flint and Westerville.

**STEBENVILLE, O.**—Thomas Johnson, T. Barclay, G. W. McCook, R. Sherrard and Dr. Stanton, buy the Steubenville street railway for \$12,357. They will re-equip (electrically) and operate it.

**SPRINGFIELD, O.**—General Manager Nelson, of the Springfield Street Railway, urges the company to refit the system and spend \$75,000 in improvements for rolling stock and electrical equipment.

**MANSFIELD, O.**—Samuel Huenerfauth, former manager of the Citizens' Street Railroad, has become identified with the Card Electric Company and A. J. Haycox, of Cleveland succeeds him.

**AKRON, O.**—Judge Nye has dissolved the injunction suits brought against the Akron Street Railroad by Thomas Post and the Falls Rivet and Machine Company, and work is going ahead rapidly.

**COLUMBUS, O.**—Columbus Central Railway Company has determined to build several long extensions southward. John J. Shipherd, of Cleveland, is at the head of the enterprise. Yost & Packard are planning the power house and barns.

**TOLEDO, O.**—The Consolidated Street Railway Company is in the field for the city lighting contracts, to be let in September. The Subsidiary Company is incorporated at \$100,000 by Chas. Wright, A. E. Lang, W. S. Jewell and R. H. Baker.

**TOLEDO, O.**—The two proposed Toledo-Maumee & Perrysburg electric lines are to be consolidated. The consolidated scheme will then connect with the Toledo consolidated.

The consolidated asks for two extensions to make the connection with the country lines.

**LORAIN, O.**—The village council has granted a franchise to Tom L. Johnson, A. J. Moxham and W. T. Bien, stockholders in the Lorain Street Railway Company, to build and operate an electric railway system through the streets of the town. The old road, over which horse cars are now running, will be torn up and the work of grading for the new system will be begun at once.

**TOLEDO, O.**—A new Electric Railway called the Toledo, Presque Isle & Nilosean Beach Suburban Railway is incorporated. The incorporators are Frank B. Losee, Capt. David W. Stroud, Henry T. Niles, Adam Burger and Horace Potter. The capital stock has been divided into shares of \$12 each, that the citizens of Toledo may co-operate with the incorporators in the building of the road.

**CINCINNATI, O.**—The Cincinnati, Middletown & Dayton Railway Company, to build electric line between towns mentioned, is getting right of way. Those interested are: Mr. H. B. Morehead, of Cincinnati, president of the company; Judge Dennis Dwyer, of Dayton; W. A. Mays, of Miamisburg; O. M. Gottschall, of Dayton; Postmaster John Zumstein, of Cincinnati, and O. B. Brown, of Dayton.

**COLUMBUS, O.**—Central Street Railway Company has following official list: John J. Shipherd, Cleveland, president; M. H. Neil, first vice-president, and Thomas A. Simons, second; E. W. Radder, Cleveland, secretary; G. W. Meeker, assistant secretary; F. W. Merrick, attorney; Barney McGighe, New York, superintendent of engineers; C. F. Fitch, Brooklyn, assistant; J. W. Doherty, New York, superintendent of construction; Joseph Cooper, assistant; local directors, H. H. Neil, T. A. Simons and G. W. Meeker.

## Oklahoma.

**GUTHRIE, OKLA.**—Chas. J. Fitzgerald, of this town, will get a street railway franchise. He promises to build line in six months.

## Oregon.

**PORTLAND, ORE.**—Thomas N. Strong, attorney for the bondholders of the Portland Cable Railway Company, is having estimates prepared of the cost of electrifying the road from the power house to the northern terminus at the Union depot.

**PORTLAND, ORE.**—The following equipment is for sale: Electric rolling stock, line equipment, steel rails and steam plant for sale cheap, in lots to suit buyer. Apply to S. Z. Mitchell, Portland, Ore.; W. J. Grambs, Seattle, Wash.; J. R. Mason, Port Townsend, Wash.

## Pennsylvania.

**POTTSVILLE, PA.**—The Schuylkill electric railway is transferred to the Philadelphia syndicate. J. B. Stuart is made general superintendent.

**LANCASTER, PA.**—The Pennsylvania Traction Company has permission to relay its tracks on East King street. Very heavy construction will be used.

**SHENANDOAH, PA.**—The borough council extends right of way of the Lakeside Electric Railway on several streets, and to connect with the Schuylkill Traction Company.

**BRADFORD, PA.**—Bradford Electric Railway Company organizes: President, Lewis Emery, Jr., Bradford; secretary, J. B. Steele, Bradford; C. S. Whitney, Belmont, N. Y., is interested.

**LANCASTER, PA.**—The Columbia & Donegal Electric Railway was formally transferred to the Pennsylvania Traction Company, July 1. B. J. McGraun is empowered to act for the stockholders.

**STROUDSBURG, PA.**—A line from here to Port Jarvis is proposed. W. H. Dimmick and Charles E. Hague, of the Union Electric Construction Company, of Philadelphia, are arranging the route.

**MEADVILLE, PA.**—F. B. Krause, secretary of the Electrical Engineering Company, of Cleveland, O., is investigating the feasibility of a street railway to connect Meadville with various other towns.

**PHILADELPHIA, PA.**—L. Calvin Mans, Philadelphia, is president of the newly chartered Philadelphia & Trenton Electric Railway, to which J. Uhle Bethell has subscribed nearly all the stock. Capital, \$150,000.

**POTTSVILLE, PA.**—W. H. Conrad has resigned superintendency of the Schuylkill Electric Railway. He has two positions offered him, one with the General Electric Company and one as superintendent of a street railway.

**TARENTUM, PA.**—The officers of the Tarentum Passenger Railway Company are: B. F. Rafferty, president; F. R. Dravo, treasurer, and J. B. Crawford, secretary and superintendent.

**ALLEGHENY, PA.**—The Monongehela & Allegheny Railroad Company is chartered at \$60,000 capital to build a line six miles long. The president is George T. Richardson, of Pittsburg. The directors are James Doig, L. H. Partridge, James Duncan, Jr., William Smith, C. H. Sackrider and R. S. Frazier, of Pittsburg.

**PHILADELPHIA, PA.**—The select council has passed ordinances permitting the Brown & Parrish Streets Railway Company to construct a trolley line, and granting like privileges to the Citizens' East End Company, beginning at Marshall and Berks streets, and to the North End Company, beginning at Sedgely and Germantown avenues.

**SCRANTON, PA.**—H. H. Archer resigns the general management of the Scranton Traction Company. Taylor Archer, master mechanic, also resigned. J. R. Beeten succeeds the general manager, and Robt. F. Fox takes the place of Taylor Archer. General Manager Archer resigns on account of ill health, and the master mechanic on account of his brother's resignation.

**BUTLER, PA.**—A charter has been granted at Harrisburgh to the Butler Traction Company, with a capital stock of \$75,000. Joseph Hartman, president of the Butler County National Bank, is president. J. V. Ritts and I. G. Smith, of the National Bank, and John Berg, of the banking house of John Berg & Co., form the board of directors.

**HARRISBURG, PA.**—The Harrisburg & Mechanicsburg Electric Railway Co. has sold its franchise to the Cumberland Valley Traction Company. The gentlemen interested are: President, E. Z. Wallower, Hon. B. F. Meyers, H. C. Ross, H. B. Mitchell and Naudain Hamilton, of the Harrisburg and Mechanicsburg Company, and S. R. Ickes, president, and O. A. Ormsley, of the Cumberland Valley Traction Company.

### Rhode Island.

**WOONSOCKET, R. I.**—The Woonsocket Street Railway is granted additional franchises.

### South Carolina.

**COLUMBIA, S. C.**—The Belt Electric Railway line is now assured. It will operate in July. The Columbia Electric Railway Company will build two long extensions also.

### Tennessee.

**KNOXVILLE, TENN.**—West End Electric Railway Company has let contract for extension of the Highland Avenue line. Other extensions are to be made.

**NASHVILLE, TENN.**—Nashville Traction Company, successor to the Overland Electric Railway, has organized by the election of F. W. Hunter, president and general manager; James Compton, vice-president, and Thomas Taylor, secretary and treasurer.

**CHATTANOOGA, TENN.**—The Chattanooga Electric Street Railway has been placed in President W. T. Adams' hands as receiver, on application of the St. Louis Trust Company. All claims must be filed in the U. S. Circuit Court. Alleged liabilities, \$650,000.

**NASHVILLE, TENN.**—The Nashville Traction Company has secured a charter. The company is organized to purchase the Overland Railroad of Rudolph M. Hunter, who bought it at a recent sale. Improvements are to be made. The officers of the new company are F. W. Hunter, president, and Thomas Taylor, secretary.

### Texas.

**CORSICANA, TEX.**—R. B. Moffet buys the street railway and will improve and operate it within 90 days.

**GREENVILLE, HUNT COUNTY, TEX.**—A local company has applied for a street railway franchise here. It is referred to council committee.

**FT. WORTH, TEX.**—In the petition of the International Trust Company versus the Ft. Worth and Arlington Heights Street Railway, Judge Harris appoints Robert McCart as receiver. He will take charge of all properties of both railway and the Improvement Association.

### Virginia.

**RICHMOND, VA.**—Judge Simonton, of the United States Circuit Court, has appointed A. M. Seddon, receiver of the Richmond & Manchester Electric Railway, with authority to take temporary charge of both companies.

G. E. Fisher, general manager of the Richmond Railway & Electric Company, says that the company is solvent and expresses surprise at appointment of receiver. He will ask that the injunction be dissolved.

**NORFOLK, VA.**—The purchasers of the Norfolk Street Railroad elected the following officers: Murray A. Verner, of Pittsburg, Pa., president; Thomas Clyde, of New York, vice-president; H. C. White, head, of Norfolk, secretary and treasurer; W. H. White, of Norfolk solicitor; M. A. Verner, W. P. Clyde, H. C. Whitehead, Thomas Clyde, and A. E. Krise, directors.

### Washington.

**EVERETT, WASH.**—City council grants franchise to the Everett Railway & Electric Company, with transfer stipulations.

**SPOKANE, WASH.**—The Spokane & Montrose electric line, better known as Cook's railway, has been transferred to the Provident Trust Company to secure bonds. A large amount of real estate has also been transferred by Francis H. Cook, president of the Electric Company, to Charles G. Reeder, manager of the Trust Company.

### Wisconsin.

**GREEN BAY, WIS.**—The Fox River Electric Railway has begun operation. W. P. Harvey is manager, assisted at present by C. H. Holmes, of Racine.

**MARINETTE, WIS.**—J. I. Scott, Louis Leisen, W. A. Curry and Andrew Matison ask for a franchise for a street railway here for a summer resort electric line.

**LA CROSSE, WIS.**—The La Crosse & Onaska Street Railway has elected the following officers: President, Hon. F. Pooler; vice-president, J. B. Canterbury; secretary and treasurer, J. E. North; executive committee, Hon. Frank Pooler, J. B. Canterbury and J. E. North. Peter Valler, of La Crosse, superintendent. A contract has been made with parties at La Crosse for a term of years, to take care of the cars and furnish power to operate the line.

### Russia.

**ST. PETERSBURG, RUSSIA.**—The street railway system here will be changed to electric, and asks bids on equipment. No favoritism will be shown. Write to H. N. Mollwo, 72 English Quay, St. Petersburg, Russia, for full particulars.

## PATENT GROOVED SABLE RAWHIDE BELTING.

The well-known qualities of the belting made by the Shultz Belting Company, St. Louis, namely, durability and power, arise from the fact that the material is tanned only on the surfaces, thus preserving a rawhide interior with a soft kid finish on the driving surface. This is claimed to give better contact with the pulley and yet not detract from its durability and power.

The latest improvement of this able company is the patent grooved sable rawhide belt, shown in our engraving.

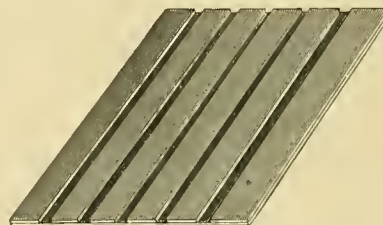

It is made of the same oak tanned material as the other belts, with the peculiarity, obvious to the eye, of grooves running lengthwise. These grooves are intended to serve as channels for the escape of air, thus obviating the air cushion, without the necessity of puncturing the belt. The grooves are kept constantly clean by the air current itself and it may be run either with slack top or bottom. The company has the highest confidence in the grooved belt and will send it on trial to responsible parties. The St. Louis Electric Light & Power Company, having three of this style of belt for two years, says that it is a good driver, runs slack, shows no sign of wear and is perfectly noiseless.

## EXPERIENCES OF A SUPERINTENDENT.

By C. P. Young.

## PART V.

Opinions differ greatly in regard to what kind of men make the best motormen. Some contend that old horse car drivers make very good ones and others say they do not. I belong to the latter class, and have tried hundreds of them and have never seen but two of the whole number become what are considered good motormen. They never learn to handle the controller right; they are too rough on the brake, and as a rule are too slow in case of trouble; they are more or less afraid, and never develop intuition to quickly locate anything that may be wrong. Their whole previous experience has blunted their mental faculties and so dulled them that it is almost impossible to make them feel the responsibility of their new position. The best men, in my experience, are between 28 and 36 years of age—none younger or older.

I have had splendid success with ex-brakemen, firemen, and men who have worked more or less around machinery. I find all ex-steam railroaders to be very rough in the beginning, but by constant watching and talking to them, and by explaining everything, they soon outgrow their roughness and become first class men. I also find that express wagon drivers do very well. A few raised in the country who have lived in the city a few years do very well but are slow to learn.

The motorman, more than any man on the whole road, has in his keeping the welfare of the road. He should therefore be a man of great judgment and coolness, should have presence of mind, and thoroughly understand everything about the car. If roads would take more pains to select and train their motormen, their accidents, lawsuits and repairs would be much less. Their work is a great deal harder and they carry a great deal more responsibility than the conductors, so that they should be better paid than the conductor.

Conductors' positions can almost be filled by petticoats, as their principal talents must be honesty, politeness, gentleness, and a quick eye, together with sobriety and neatness. Their greatest virtue should consist in knowing how to handle cranks, and to make friends for the road instead of enemies, especially in cities where competition exists. Married men make the most honest, and, in fact, the best conductors, hence I always prefer them. Presidents and directors should carefully analyze what kind of motormen and conductors are in charge of their cars, and a superintendent should be a keen judge of human nature, so as to select the right kind, for a great deal depends upon these men. They stand between the company and the public, and make the road popular or unpopular. By having men (not slaves, as some roads seem to prefer) that take interest and pride in their cars and work, they undoubtedly increase the revenue of the road. If only two fares are missed or lost on each half trip, and a car makes say thirty half trips per day, this makes \$3 per

car. On a hundred car road this makes \$300 per day, and in a year \$109,500, which is equal to the interest at 5 per cent on a capital of \$2,190,000. At the directors' meeting this means something, and ought to show them what kind of management they have. If the men are the right kind and they are managed properly the road will be in the above sum, while if, on the other hand, they are not the right kind and mismanaged, the road is the loser in missed fares and a disgusted public, who only as a matter of necessity patronize the cars. Untrained and careless motormen will use too much current, rawhide the motors, injure the trucks, cars, tracks and overhead construction, increase accidents, and, in fact, depreciate the value of every detail part of the road, which as a matter of course keeps dividends down and makes directors and stockholders disgusted, and the road a failure as far as profit is concerned. This is to-day the trouble with a large number of roads. A great writer on political economy, after a thorough inspection of the steam railroads in Germany, said that they might well employ a Vanderbilt and pay him \$1,000,000 a year to reorganize their railroads, and they would be the gainer by at least \$10,000,000 a year. This may with equal emphasis be applied to most electric roads. If they would employ better men and not be so stingy on the salary they would very likely profit by it. The majority of business men would gladly pay \$10,000 for the sake of earning \$100,000, but the majority of electric railroad directors and presidents do not see things in this light, and hence their investments have not come up to their expectations.

Every power house should have a fire alarm, so as to inform the engineer in what locality and street the fire is located. All streets should have their own feeders, and they should be so arranged on the switch board that any feeder can be cut out without disturbing the others.

Every feeder should have a circuit breaker, and a gong alarm should be attached to each circuit breaker, so that if one cuts out, the engineer is immediately notified by the ringing of its gong. In larger cities, where there are several roads, there ought to be a lineman's tower wagon with all necessary tools and one expert and one assistant lineman at no less than four fire stations. In case of fire this wagon and lineman should hasten with the engine to the place of the fire to attend if necessary to the cutting of wires and afterwards repairing the same. The expenses should be paid by the various roads according to their mileage. In smaller cities where this would be too expensive, a tower wagon should always be ready for use in case of fire.

Electric railroading is no longer an experiment; it is a positive science and a business that ought really to be the very best investment in the business world of to-day. It is a business that is carried on no less than eighteen hours per day, three hundred and sixty-five days per year, and is cash down. When other industries are standing still on Sundays and holidays, then come the best days for an electric road. There can be little excuse for not making them all a success. Yet many are in receivers' hands and a very few are a success. This is due to tw

great causes, viz: cheap and imperfect installation and ignorant management. A properly installed and operated electric railroad ought to be maintained at between 33 and 40 per cent of the gross receipts. If your road is not operated within this figure something is wrong, and the sooner you set to work to locate your leaks and remedy them the better for every one. If you neglect this you are the wrong man in the wrong place, and the directors ought to look for a new manager. If railroads were built in the following manner they would inevitably be a financial success. Power houses located if possible about the middle of your system at a place where water can be had free. Get your coal either by boat or car right up to your power house. Automatic coal conveyers, economic boilers, slow speed compound condensing engines, large units, multipolar generators, skilled engineers and firemen, a good track with no less than 63 pound rail laid on large ties no more than two feet apart, all laid on well tamped ground and plenty of ballast. Plenty of copper in your feeder system, a complete metallic circuit for your ground return, convenient car barns with all necessary tools, good machine, carpenter and paint shops, skilled and well trained mechanics. Single reduction motors on easy running trucks. Well built and strongly put together cars. Well trained motormen and conductors. Good and sure lightning protectors. Above all, have a thorough man to operate your road, well posted in all departments and details of the science of electric railroading, and then leave him alone free to act.

I plead for a higher class of employes and a better management of property and men engaged in this new enterprise or profession. If the few grains of thought and experience that I have scattered in these pages should be read by some financially interested in electric roads and my advice be acted upon, I shall consider that the time I have taken between busy hours well invested and my labor well repaid.

## STREET RAILWAY PATENTS.

ISSUED JUNE 5, 1894.

Electric motor truck. John C. Henry, Westfield, N. J.....	520,780
Electric motor controller. William J. Hopkins and Theodore Stebbins, Boston, Mass., assignor to the Thomson-Houston Electric Company of Connecticut.....	520,784
Electric locomotive. Walter H. Knight, Lynn, assignor to the General Electric Company, Boston, Mass.....	520,787
System of circuit control for electric machines. Charles E. Davis, Chicago, Ill., assignor to John H. Leslie, same place.....	520,822
Fender for railway cars. John E. McBride, New York, N. Y.....	520,857
Railway rail chair. Henry O'Shea, Johnstown, Pa., assignor by mesne assignments to the Johnson Company of Pennsylvania.....	520,860
Railway frog. Henry O'Shea, Johnstown, Pa., assignor to the Johnson Company, same place.....	520,861
Trolley wire support. Louis McCarthy, Boston, Mass.....	520,937
Closed conduit for electric railways. Paul Plodeck, Sr, Cleveland, O.....	520,938
Electric overhead switch. Miller A. Smith, Brooklyn, and William Clabaugh, New York, assignors to the New York Electrical Works, New York, N. Y.....	520,971
Trolley. Edgar M. Tousley, Jamestown, N. Y.....	520,973

Converter system for electric railways. George Westinghouse, Jr., and Chas. F. Scott, Pittsburg, Pa.....	520,975
Conduit electric railway system. James B. Brand, Milwaukee, Wis.....	521,010

ISSUED JUNE 12, 1894.

Contact trolley. Robert W. Hawkesworth, East Orange, N. J.....	521,163
Bond for electrical conductors. John Herr, Philadelphia, Pa.....	521,238
Pilot or guard for cars. R. A. Crawford, Allegheny, Pa.....	521,307
Trolley wire finder. T. E. Gressle, Indianapolis, Ind., assignor of nine-twentieths to Frank Hittle, Baltimore, Md.....	521,311
Conduit system for electric railways. Harry Alexander, New York, N. Y.....	521,326
Safety attachment for car coupling. John A. Markley, Clifton Forge, Va., assignor of three-fourths to Jas. Clivre Carpenter, J. A. Roberts, J. Z. Duncan and J. C. King, same place.....	521,243

ISSUED JUNE 19, 1894.

Safety appliance for street railway cars. Oswald R. Routh, Jersey City, N. J.....	521,477
Cable street railway. Fred Hoch, Wauwatosa, Wis.....	521,500
Fender for cars or locomotives. James B. Krause and Robert H. Crosby, Williamsport, Pa.....	521,593
Conduit electric railway. Thomas Annat, Washington, D. C.....	521,562
Trolley pole catcher. Owen G. Cates, Jr., St. Louis, Mo.....	521,602
Electric railway car motor. John C. Henry, Westfield, N. J.....	521,651
Coupling for electric locomotive. Edward D. Priest, Lynn, assignor to the General Electric Company, Boston, Mass.....	521,669
Safety car fender. Frederick H. Reich, Baltimore, Md.....	521,670
Fender for tram cars. Samuel J. Rosenfield, New York, N. Y., assignor by direct and mesne assignments to himself and Joseph A. Louchheim and Edwin S. Simon, Philadelphia, Pa.....	521,672
Supply system for electric railways. Thomas Harris, Detroit, Mich.....	521,711
Car fender. James Tobin, Indianapolis, Ind.....	521,741

ISSUED JUNE 26, 1894.

Railway car truck. Norman C. Bassett, Lynn, Mass., assignor to the Thomson-Houston Electric Company, of Connecticut.....	521,778
Conduit electric railway. Charles J. Reed, Orange, N. J., assignor by direct and mesne assignments to the Reed Electric Company, Philadelphia, Pa.....	521,891
Conduit electric railway. Chas. J. Reed, Orange, N. J., assignor to the Reed Electric Company, Philadelphia, Pa.....	521,892
Safety guard for cars. August Soffel, Brooklyn, N. Y.....	521,866
Safety appliance for street railway cars. Frank W. Jenkins, Brooklyn, N. Y.....	521,981
Trolley stand. Eleazar F. A. Hastings, Avalon, Pa.....	522,057
Car fender. Marguerite Maidhof and Victor F. Maidhof, New York, N. Y.....	522,070
Automatic switch operating mechanism. Cyrus P. Bachelder, Pawtucket, R. I.....	522,096
Life guard for cars. Joseph J. Beals, Cambridge, assignor one-half to Wallace L. Broadbent, Boston, Mass.....	522,099
Safety guard for cars. Joseph W. Betz, Brooklyn, N. Y.....	522,100
Wheel fender and safety attachment for street cars. Frank H. Homan, Patchogue, N. Y.....	522,115
Flexible fender for street railway cars. Richard B. Chambers, Chester, Pa., assignor to Crosby M. Black, same place.....	522,147
Trolley wire hanger. Thomas J. McTighe, New York, N. Y., assignor by mesne assignments to Frederick K. Fitch, same place.....	522,180

SEVERAL years ago the consolidated Street Railway Company of Cleveland, O., put into service a number of McGuire Manufacturing Company's trucks. Since that time trials have been made by the Consolidated of a number of different other makes, but came back to the McGuire people with an order for 80 trucks. It is a compliment to the McGuire specialty that is fully appreciated by that company.



THE western department of the Chas. A. Schieren Belt-  
ing Company reports a first-class summer trade.

W. D. HOFFMAN succeeds Huxley & Hoffman as Bos-  
ton agents for the Buckeye engine, of Salem, O.

THE Chicago agent of the Heine boiler, James H.  
Harris, has removed from McVicker's Theater building to  
1521 Monadnock.

THE McGuire Manufacturing Company has bought  
the Christensen air brake patents and will put it on the  
market guaranteed.

THE Dodge Manufacturing Company, of Mishawaka,  
Ind., has opened a Boston office in charge of F. W.  
Underwood, at 137 Purchase street.

THE C. D. Morse Car Manufacturing Company, of  
Millbury, Mass., does a large business in interior house  
finishing in addition to its car building.

THE American Electrical Works, of Providence, R. I.,  
have decided to open a Chicago wareroom and sales  
office under charge of Francis E. Donohue.

THE International Register Company, Chicago, reports  
through Manager Englund, an excellent business and  
bright prospects for the International fare register.

THE Card Electric Company, of Mansfield, O., sends  
us the cheering news of the sale of ten equipments. For  
a company so young, in a field so crowded, the Card  
people have ample reason to congratulate themselves.

J. S. GUSTIN & Co., Chicago, report orders for the  
Hercules trolley clamp, numerous, and enquiries coming  
in strong. As the clamp can be fitted to any style of  
hanger, managers easily appreciate the convenience of it.

THE Abendroth & Root Manufacturing Company, 28  
Cliff street, New York, still keep up with the boiler pro-  
cession. The Root improved water tube boiler is strictly  
high class, and merits its patronage of street railway and  
light men.

THE Graham Equipment Company has established its  
own plant at Providence, R. I. and those enterprising young  
men at the head of the enterprise, namely, J. H. Graham  
and G. S. A. Gardiner, find their hands full of work.  
Trucks are now under construction for Atlanta, Ga.,  
Boston, Mass., Trenton, N. J., and Hazleton, Pa. All  
machinery in the factory is run by electricity, and three  
tracks are available for assembling the trucks.

THE Chicago Electric Truck Company, Chicago, is  
about to erect a plant for the manufacture of the excel-  
lent truck of that name. This move will give the com-  
pany ample means of filling any number of orders for its  
popular and easy riding truck.

BEST, FOX & COMPANY, Philadelphia, Pa., of which  
W. K. Mitchell is general sales agent, make a specialty  
of pipe fitting and castings for street railway power  
stations. Among its specialties are blast furnace tuyeres,  
coolers, bosh plates, cinder notches and pipe bending of  
all sizes up to twenty-four inches.

WE have recently seen a series of bonds of a small  
Illinois railroad. These bonds were engraved by the  
Western Bank Note Company, of Chicago, and are ele-  
gant samples of the excellent work of this company,  
which makes a specialty of engraving such documents  
for street railways and similar corporations.

AT the invitation of John Farson, twenty gentlemen  
and their ladies made a formal tour of inspection of the  
Calumet Street Railway, Chicago. The entire fifty miles  
of track was traversed and the visitors entertained by  
Superintendent Oliphant. The celebration was finished  
by a luncheon at the Hotel Florence, Pullman.

THE Jackson & Sharp Car Company, Wilmington,  
Del., reports sales of 150 cars distributed among the fol-  
lowing roads: Tonawanda & Buffalo, N. Y.; Hartford,  
Conn.; New Bedford & Fall River Railway, Mass.;  
Gardner, Mass.; Akron, O.; Hazleton, Pa.; and 100 cars  
for the Electric Traction Company of Philadelphia.

THE McGuire Manufacturing Company, Chicago,  
reports the sale of 170 of the well-known McGuire  
trucks to the Philadelphia Traction Company, together  
with a call for 50 from Norfolk, Va.; 10 for Green Bay,  
Wis.; 18 for Toledo, O., and a number of smaller orders.  
This looks like business, and a revival in street railway  
industry.

THE Bristol, Eng., "Times and Mirror" of June 5,  
says: THE STREET RAILWAY REVIEW, a bulky monthly,  
published at Chicago, gives in its May number a descrip-  
tion of the Bristol Tramway system, with illustrations of  
one of the new double-decked cars and of the Suspension  
Bridge, and a portrait of Mr. Challenger, the general  
manager.

T. ISBESTER and H. Woodland, both of whom have  
been connected for many years past with the Utica Head-  
light Company, have severed their connection to repre-  
sent and handle in the west the products of the Star  
Headlight Company, of Rochester, N. Y. They have  
commodious offices in the Western Union building, in this  
city, and have already entered upon a vigorous campaign  
in which their light will not be concealed under a peck  
measure.

THE Mark Railway Equipment Company, recently reorganized in Illinois, has opened offices at 564 Monadnock Block, Chicago. The new company has as president, C. E. Marks; C. H. May, vice-president, and Geo. T. Warren, secretary and treasurer. The specialties to be marketed are rails, rail chairs, joint bridges, crossings, ties and spikes.

THE Mica Roofing Company, 73 Maiden Lane, New York City, sends the REVIEW samples of "mica" building paper, which is applicable to buildings for every circumstance requiring sheathing, particularly under metal roof. It is odorless and water proof, and not a coal tar product. It is said to be saturated with an odorless mica compound, and to be acid proof as well.

HOOVEN, OWENS & RENTSCHLER, of Hamilton, O., are congratulating themselves over the good record made by their tandem compound condensing Corliss, in a test made at the Lynn & Boston Railroad's plant, at Salem, Mass., by J. H. Bickford and G. H. Davis. The engine took 14.87 pounds of steam per indicated horse-power hour, working on an approximately steady load.

THE Mosher Electric Company, the Chicago Nickel Works and the Reimann Company have been consolidated, and will hereafter be known as the Union Brass & Manufacturing Company. The offices and plant will be as before at the corner of Ontario and Franklin streets. The president is Adolph Weinberg, formerly treasurer of the Adams & Westlake Company.

THE Wallace Electric Company, Chicago, has just added a line of electrical house goods, and has in preparation an extensively illustrated catalogue. The goods are the standard devices formerly sold by the Ansonia Electric Company but now handled by the Wallace Company as general western agents. No shopworn or old type goods are handled, but all are new and complete.

THE Ellis Manufacturing Company, 218 South Fourth street, Philadelphia, is now manufacturing and selling the excellent Hansell truck. The officers of the company are: Harvey Ellis, president, and Joel C. Hancock, secretary and treasurer. Both of these gentlemen are well-known in street railway circles, having been connected for eighteen years with the Cambria Iron Company.

THE Consolidated Car Heating Company, of Albany, N. Y., has acquired the sole right for the United States of introducing the Pope system of car lighting by means of compressed oil gas. Many English railroads have adopted the Pope system, which is claimed to be as efficient as the Pintsch method. A number of contracts have already been made for American roads and correspondence on the subject is solicited. At present over 14,000 English cars are said to be equipped with the Pope light.

STERN & SILVERMAN, Philadelphia, report business good in all departments. In railway contracts they have undertaken the reconstruction of the Brigantine Transit Company's road, Brigantine Beach, N. J., which will require seven miles of trestle. Other contracts are: an extension of the Logan Valley Railroad for the Pennsylvania system, eight miles, and the Roxborough Incline Plane & Railway, six miles, running from Philadelphia to Barren Hill.

THE Composite Brake Shoe Company, Boston, has arranged with the Kinzer & Jones Manufacturing Company, of Pittsburg, Pa., for the manufacturing and delivering of composite brake shoes. This latter company will have charge of the district contiguous to Pittsburg and for the present of the country west of the Alleghenies and southern points. All orders should be sent to Boston, where all business is transacted. In case of great need, duplicate orders may be sent to Pittsburg also.

THE Clonbrock Steam Boiler Works, Brooklyn, N. Y., makers of the famous Morrin Climax steam generator, for the United States, have just closed a contract for a 4,000 horse-power Climax generator, with the Edison Electric Illuminating Company, First District, Pearl street, Brooklyn, N. Y. The great success of the Climax boiler since its recent introduction to power users of this country, has been due to the absolute merits of the specialty and the courteous treatment accorded all by the American makers.

MICANITE, is the title of a 24-page pamphlet issued by the Mica Insulator Company, 218 Water street, New York City, sole manufacturers of the high grade insulation of that name. Micanite commutator segments, troughs, transformer spools, cloth, paper, washers and insulators for rheostats are illustrated and described, as well as listed as to size. A number of testimonials as to the reliability of the material are published. The line of insulators has been largely increased, and a growing demand is found for the material in Europe. The brochure may be had on application.

AN article in the Watertown, N. Y., Daily Standard of April 6, on the Watertown Electric Street Railway, under the successful management of Superintendent G. W. Adams, contains the following reference to the rawhide pinions of the New Process Rawhide Company: "Two rawhide pinions, purchased of the New Process Rawhide Company, of Syracuse, N. Y., running about eight months in car No. 10 of the street railway company, have made a mileage of about 21,000 miles. These pinions make five revolutions for every time the car wheel moves around once, an average of about 400 revolutions per minute. In this 21,000 miles the wheels of car 10 made 13,440,000 revolutions, and the armatures and pinions have made 67,220,000 revolutions." The pinions in question, we learn, are still in regular service, and "the end is not yet."



THE Mather Electric Company, of Manchester, Conn., is in receipt of encouraging orders for its new direct connected and belted generators for railway and light work. Fourteen years' experience in the business gives the Mather Company ample precedent for its excellent work. J. Holt Gates, 1139 & 1140 Monadnock Building, Chicago, general western agent, reports a good, steady business.

E. J. WESSELS, formerly of the Short Electric Railway Company, has been appointed general manager of the Genett Air-Brake Company, with offices at 33 Wall street, New York. These offices are conveniently located in the heart of the financial district. Mr. Wessels reports business very promising. The company has just closed a contract with the New Orleans, La., Traction Company to equip a number of its cars with its air-brake. Mr. Wessels' intimate knowledge of the street railway business and his large acquaintance among managers will make him very efficient in his new capacity.

THE Garton-Daniels Electric Company, of Keokuk, Ia., reports a gratifying increase in the sales of the well known Garton lightning arrester. The coming of spring thunder storms brought out some serious thoughts on lightning losses among many managers, who forthwith invested in Garton arresters. Recent foreign shipments to Siemens Brothers & Company, Woolwich, England, will be placed on the Tasmanian, Australia, lines, now being built. The Siemens Company also used the Garton on its Panama, C. A., line, built a year ago. This second order means the success of the first one.

THE Union Brass Manufacturing Company, of Chicago, is the caption of a new corporation composed of the Chicago Nickel Works, the Reimann Company and the Mosher Electric Company. The consolidation has its offices and plants at the corner of Ontario and Franklin streets, Chicago. The president of the organization is Adolph Weinberg, late treasurer of the Adams & Westlake Company. A general line of hardware specialties and electric lamps will be made, and the concern is well equipped to promptly execute all orders in its line.

The well-known Mosher arc lamp will be the principal point of interest to our readers.

MANY THANKS.—We doff our hat to our enterprising electrical contemporary across the water, which stands representative of all electrical industry and progress in Italy, and which is doing much to promote things electrical. *L'Elettricista*, published at Rome, Italy, has the following appreciated mention:

"The STREET RAILWAY REVIEW, a splendid monthly review, in Imperial quarto size, published at Chicago, and devoted chiefly to everything that regards tramways, is illustrated with such a wealth of beautiful engravings as to completely obscure the very best of our old world periodicals 'con una ricchezza di incisioni che è affatto sconosciuta ai migliori periodici del nostro vecchio mondo.'"

THE Electrical & Mechanical Engineering & Trading Company, 39 Cortlandt st., New York, of which J. H. Vail is president, has in hand, besides a large number of electric light plants, contracts for car house, cars, motors, trucks and generators for Hoosick Railway Company, Hoosick Falls, N. Y.; and acts as supervising and consulting engineer for the Poughkeepsie City & Wappingers Fall Electric Railway Poughkeepsie, N. Y. This plant will involve a 600-horse-power steam plant, and there will be some fine long distance work, as one section of the road extends ten miles to the towns of Wappingers Falls and New Hamburg, operating cars in and between both towns. The plant will incorporate the use of Sterling boilers, compound condensing engines, direct driven General Electric generators and G. E. 800 motors.

THE Composite Brake Shoe Company, 620 Atlantic avenue, Boston, has succeeded to the business and all rights, titles and interests of the Safety Brake Shoe Company, Boston. The safety brake shoe, which has been constantly growing in favor with managers, has now larger facilities and abundant capital to carry on the most extensive operations. The specialty has in no wise departed from its original standard of efficiency and wearing qualities, and William W. Whitcomb still remains at the head of the organization, as popular and as progressive as of yore. We congratulate him upon the success of his invention and his increased facilities for marketing it. Geo. C. Ewing remains as superintendent, and Chas. H. Burrage is made secretary and treasurer. President Whitcomb's energy and persistency is to be applauded in this extension of his usefulness.

FEED WATER heating and purifying according to Hoppes makes a very interesting story. A list of the concerns lately adopting the Hoppes live steam feed water purifiers and exhaust steam feed water heaters, includes the Citizens Street Railway Company of Muncie, Ind.; the Columbus, O., Street Railway Company, which bought 1,000 horse-power; the Waco, Tex., Electric Railway & Light Company, 800 horse-power heater; Peoples Traction Company, Philadelphia, 3,000 horse-power heater; Calumet Street Railway Company, Burnside Crossing, Ill., 1,000 horse-power purifier, and the Bay City, Mich., Union Railway Company 400 horse-power purifier and 400 horse-power heater, besides a large number of gas and electric light plants that recognize the value and economy of these appliances. The offices of the Hoppes Manufacturing Company are at Springfield, O.

Two little girls, presumably not in blue, at Elmira, N. Y., were barely saved alive by the frantic efforts of the motor man to stop his car. When the children were asked why they had gotten in front of the car, one of them spoke up and said: "Why, we wanted to see how it would feel to be dead," and sure enough they had stepped on the track with the determination of being run over.

F. A. SEIBERLING, of the Akron, O., Street Railway Company, was a June visitor in Chicago.

OSBURN BROTHERS, Chicago, have removed to larger quarters at 304 Dearborn street, whither increase of business has taken them.

THE Miller Electrical Works of 4 North Fifth street, have taken the Philadelphia agency for the Garton-Daniels lightning arrester.

JOSEPH PSYBYSCKI, of St. Paul, is suing for \$20,000 worth of personal damages received at the hands of the Minneapolis Street Railway Company. Joseph fell off a car and sprained his name so that he has to wear it hyphenated now, which spoils its looks.

A MULTITUDE of June bugs settled on the street railway tracks at Aurora, Ill., recently, and actually blocked

THE Altoona Manufacturing Company, of Altoona, Pa., reports the following orders for the M. A. Green automatic cut off engines, received during June: One 280-horse-power engine for the Akron Street Railway Company, of Akron, O., to be direct coupled to a 250-horse-power generator, built by the Walker Manufacturing Company, of Cleveland, O.; one 150-horse-power enclosed type self-oiling engine, for the Watson Mining & Manufacturing Company, of Monongahela City, Pa., for an electric mining and haulage plant; one 65-horse-power enclosed type self-oiling engine, for the Lyceum Theater, Philadelphia; one 175-horse-power standard center crank engine, for the Freeport Electric Company, Freeport, Ill.; one 65-horse-power enclosed type self-oiling engine, for Knight Brothers, Fayette, Ia. There is considerably more inquiry, and with a settlement of the railroad strike it is believed that a substantial improvement in business will be the result.

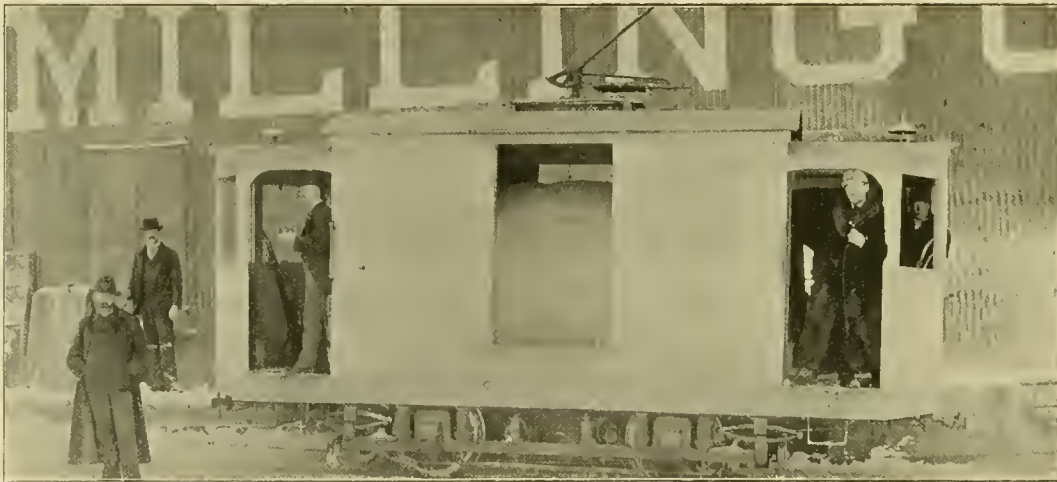

ELECTRIC GRAIN CAR AT SPOKANE.

the cars, so great was their number. A gang of shovelers was sent out and several car loads of the innocent June bugs were precipitated into the river.

THE Ohio Brass Company, of Mansfield, Ohio, is distributing to the trade a neatly gotten up price list of railway motor bearings. It includes all the different styles of bearings for the various types of railway motors. This company is pushing its line of material actively, and increasing orders show that both quality of stock and workmanship are satisfactory.

THE railway apparatus built by the Card Electric Company, of Mansfield, O., is progressing in its fame and name among the street railways. The controlling stand is favorably regarded on account of its simplicity, consisting as it does of a series of break switches, doing away with sliding contacts. J. Holt Gates, 1139-40 Monadnock building, Chicago, general western agent, reports many inquiries and an encouraging amount of work on hand. Card motors are now in operation at Fremont and Mansfield, O., where they have been thoroughly and successfully tested.

#### THE SPOKANE FREIGHT CAR.

We present herewith an engraving made from a photograph of the grain car at Seattle, described in our last issue, which arrived too late for publication with the article. The car proper is no longer than the truck, the only overhanging portion being the platforms. It is the design of W. S. Norman, general manager.

THE Newton Street Railway Company, of West Newton, and the Newton & Boston Street Railway Company, of Newtonville, Mass., have both adopted the Grinnell Dry Air Sprinkler system for fire protection in car houses and power plants. The General Fire Extinguisher Company, Providence, R. I., makes the device, which is efficient for the purpose, being automatic and positive in action.

THE Urbana & Champaign has been obliged to install a separate 150-horse-power Westinghouse generator to take care of its stationary motor business. The recent move of the insurance companies, prohibiting grounded circuits in buildings, is the cause.

THE FALK TROLLEY HEAD.

When such a large and important system as the Milwaukee Street Railway equips all its cars with a new type of trolley head within a short space of time, and even before that type of trolley is placed on the open market, there is rightly a good deal of interest manifested as to the details of the new device. The maker of the

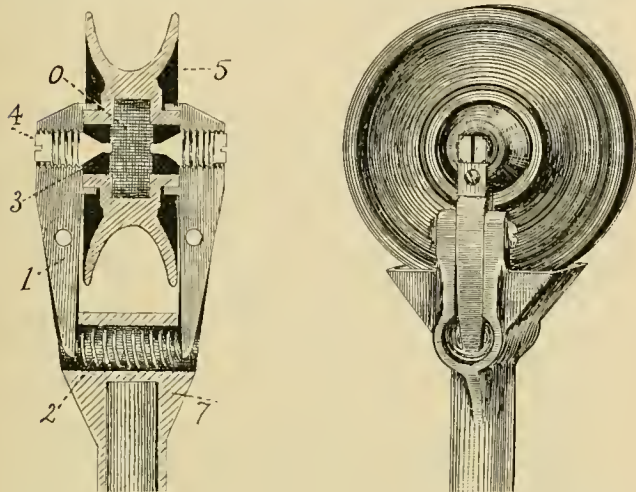

trolley is the Falk Manufacturing Company, of Milwaukee, which has good reason to feel proud of the immediate success of this, its first effort. The trolley in question discards the use of graphite bushings or roller bearings, and employs instead, cone bearings, which automatically adjust themselves to compensate for any small wear.

The detail parts are shown in the engravings. Every part is steel. Brass wheels will be furnished, if insisted

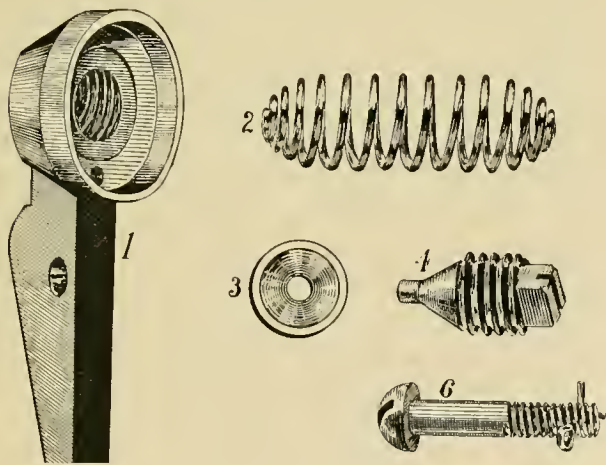

on, but their use is not recommended, as they wear out much faster than steel. As seen in the cross section of the trolley, the cone bearings are kept tight automatically by the spiral spring which presses outward on the arms which hold the cone points. This is an important feature, as it prevents rattle and keeps a good electrical contact, while, at the same time, there is a slight play of the wheel under severe strains. The cones and the wheel bushings against which they bear are of hardened steel.

To adjust the bearings for the wear which takes place in the course of a long time, the cone points can be screwed in or out with a screw driver, and the adjustment is kept by the split pin as shown. In case the cones break, there is still a shoulder to prevent the wheel from falling out, and to act as a bearing until it can be conveniently fixed. Inside the wheel is a hollow space for dope. This is applied every few nights by removing one of the cones and inserting the nozzle of a specially made dope can, which fits the hole in the bushing. When the inspector replaces the cone, he, of course, adjusts the bearing so that the spring holds the cones at the proper tension.

Thus the wheel needs absolutely no attention beyond the oiling until it is worn out. At Milwaukee, one man will dope thirty cars in an hour and a half. The harp is shaped so that it can not catch on span wires. However, the most interesting information about a device of this kind is as to its practical performance. The fact that it has been adopted by the Milwaukee Street Railway, with its trying center pole construction and small wire, shows that it is a superior article. Superintendent Lynn says that they have discarded all other types, as they proved very expensive, and that since using the Falk trolley they have had little or no expense for this item.

The steel bushings will easily last four months, which is about equal to the number of days some bushings will last. The cost of maintenance is exceedingly low. This is partly accounted for by the fact that there is never any play or rattle. A small rattle soon becomes a big one and the wear increases accordingly.

ELECTROLYSIS OF IRON PIPES.

At a meeting of the Western Society of Engineers at Chicago, July 11, Professor D. C. Jackson, of the University of Wisconsin, read a paper giving the results of a scientific investigation of the process of the electrolysis of iron pipes by railway currents as carried on by students of the University during the past year. It is unnecessary here to review all the experiments performed, but simply to state briefly the facts proved. Some trials were made with artificial solutions and some with actual street soils placed in electrolytic cells. The amount of action was determined by the loss in weight of the iron positive plates. It was found that the most action took place when the water of the soil had in solution a large amount of chloride salts. Common salt, of course, comes under this head. Nitrate salts were found to come second in destructive effect, and sulphates third. Electrolysis was found to take place to a certain extent with a very slight difference of potential. This disproves the old idea that a pressure of from one to two volts is necessary. This would be the case were the destruction of pipes caused by the electrolysis of pure water, and the consequent oxidization of the positive pole, due to the setting free of oxygen. This, Professor Jackson disproved, both by laboratory experiment and by the fact that iron pipes destroyed by electrolysis do not show signs of rusting.

From the practical man's standpoint the paper was most valuable as showing that electrolysis is as much dependent on the nature of the soil as on the size of the railway system. Not only was this shown conclusively by the laboratory experiments, but it was shown to be the case in actual experience where one road installed five months gave trouble, while others much older had no signs of electrolysis. The remedy recommended by him was that tried at Milwaukee, viz: frequent connections from pipes to rails within the district in which the current is leaving the pipes.

O. M. Rau, electrician of the Milwaukee Street Railway, was present and in the discussion which followed gave an excellent practical example of the influence which soil has on electrolytical action. One of the Milwaukee lines which has been down four years had a bare supplementary copper wire running its entire length. The two ends of the route were the same distance from the power house. On one end which was laid on lake sand, the supplementary was in perfect condition when the track was relayed a short time ago, while at the other end the supplementary disappeared over two years ago. The fact of the difference in soils had been taken advantage of in relaying lead service pipes, and as far as possible they had been covered with lake sand.

In England it has been the custom to charge double street railway fare on holidays and Sunday. The house of commons has a bill under consideration requiring a discontinuance of the practice.

THE annual report of the interstate commerce commission for the year ending June 30, 1894, is at hand. The report shows a healthy increase in nearly all items over the previous year. The number of employes per mile of line averages up 515, of which 21 were assigned to general administration, 151 to maintenance of way, 103 to maintenance of equipment, and 234 to conducting transportation. One employe was killed out of every 115 trainmen, and one passenger killed for every 1,985,153 carried. Of the stock outstanding, 61.24 per cent paid no dividends. Only 10.5 per cent paid dividends of over 5 per cent. The per cent of mortgage bonds paying no interest was 10.9 of the total. Of the income bonds 82.56 per cent paid no interest.

### Custer's Last Battlefield.

A visit to this spot, which is now a National Cemetery, is extremely interesting. Here, seventeen years ago, General Custer and five companies of the Seventh U. S. Cavalry, numbering over 200 officers and men, were cut to pieces by the Sioux Indians and allied tribes under Sitting Bull. The battlefield, the valley of the Little Big Horn, located some forty odd miles south of Custer, Montana, a station on the Northern Pacific Railroad, can be easily reached by stage. If you will write Chas. F. Fee, St. Paul, Minnesota, inclosing four cents in postage, he will send you a handsomely illustrated 100 page book, free of charge, in which you will find a graphic account of the sad catastrophe which overtook the brave Custer and his followers in the valley of the Little Big Horn, in June, '76.



### STREET CAR LICENSES IN NEW YORK.

Comptroller Fitch, of New York City, has made out the following statement in reply to a question of a Philadelphia professor of political economy. The data go back to 1880. Some companies make payments according to franchise stipulations, others are subject to municipal ordinances, while the rest are taxed under a general railroad law.

The three methods are easily recognizable from the amount of the taxes.

The Broadway and Seventh avenue and Broadway Surface Railroad paid to the city from 1885 to 1890 three per cent of its gross receipts and \$50 per annum license fee for each car; from 1890 to 1893, five per cent of its gross receipts, \$50 a car, and an additional sum of \$40,000 a year; from 1893, five per cent of gross receipts, not to be less than \$150,000 a year, and \$50 a car.

The Sixth Avenue Railroad Company, \$50 a car a year since 1889.

The Chambers & Grand Street Ferry Railroad, three per cent from 1887 to 1891, and five per cent, with \$50 horse car fee, since 1891.

The Central Crosstown Railway Company, three per cent of its gross receipts from 1887 to 1893.

The Central Park, North & East River Railroad Company, \$50 each car a year since 1886.

The Ninth Avenue Railroad Company, \$50 each car since 1889.

The Second Avenue Railroad Company five per cent gross receipts from 1890 and one-third of one per cent on extensions.

The Third Avenue Railroad Company, \$20 for each car every year from 1886 to 1893.

The Twenty-third Street Railroad Company, five per cent of gross receipts from 1890.

The Twenty-third Street Railway, one per cent of gross receipts from 1891, and \$50 for large cars and \$25 for small cars.

North & East River Railroad Company, sold at auction for thirty-eight per cent of gross receipts; unable to pay it; operated by contractors.

Hudson River Railroad Company, dummies, \$50 a year.

Elevated Railroad, five per cent net proceeds; paid nothing since 1890; suit brought by city recently decided by Court of Appeals that city can recover five per cent of net income only on passenger traffic on Ninth avenue line, between Greenwich and Sixty-first streets, and two and a half per cent from Sixty-first to Eighty-third street.

Christopher & Tenth Street Railway, paid three per cent of gross receipts since 1888.

Dry Dock, East Broadway & Battery, five per cent net proceeds, \$50 each for large cars, \$25 for small cars, since 1888.

Eighth Avenue, \$50 a car since 1882.

Forty-second & Grand Street Ferry Railroad, \$50 a car since 1888.

Forty-second Street, Manhattanville & St. Nicholas Avenue Railroad, three per cent gross receipts from 1885 to 1891, and five per cent from 1891.

Houston, West Street & Pavia Ferry Railroad, \$1,000 a year and \$50 a car.

New York & Harlem, three per cent on gross receipts of extensions from 1885 to 1893.

Twenty-eighth & Twenty-ninth Street Railroad Company, not completed, to pay three per cent on gross first five years and five per cent thereafter, to which add 29 2-10 per cent bid at time of sale.

Metropolitan Crosstown line, six per cent on gross, and \$50 a car from 1891.

Union Railway Company, one per cent gross when the average reached \$1,700 a day; paid nothing in two years.

BASLE, Germany, has decided to build a municipal electric railway between the Baden railway station and the Central railway depot.

OSWEGO, N. Y., has a 12-car road. At the beginning of the rumor of the recent strike 100 men presented themselves at the car barn looking for the strikers' jobs. The strike hasn't come off yet!

**MURPHY & BRUNING POLES.**

The firm of Murphy & Bruning, the well-known electrical experts and engineers, of Charleston, S. C., enjoy the advantage of being in the midst of a very rich timber region, and so are able to furnish direct any amount of the best electric railway poles. Shipments can be made by water, and prices made very low for northern delivery. The firm are to be congratulated on their location, and they will, no doubt, do a large electric railway business.

**THE STANDARD RAILWAY SUPPLY COMPANY EXTENDS ITS FIELD.**

The Standard Railway Supply Company, of Chicago, of which Garson Myers is president and manager, without a flourish of trumpets has built up a business that stands in the first rank of street railway supply houses in Chicago. For the last two years this company has devoted its energy to the introduction of the "Standard" Car Stove and "Gilt Edge" Steel Gongs. The excellency of the Standard stove is now known throughout the length and breadth of the land, and can be found in use on many street railways, among which are some of the largest in the country. Not only in the United States has Mr. Myers succeeded in introducing the Standard stove, but in Germany and throughout Canada as well. Contracts with leading manufacturers in these countries have been made for the manufacture and sale of his stove. A test made in Frankfort, Germany, last winter, of the Standard stove, resulted in its adoption by the German Tramway Association, which holds the same relation to the railway companies in that country as the American Street Railway Association occupies with us.

Another, and entirely new stove, has been made by this company which will be placed on the market in a short time, to be known as the Myers Self Feed Car Stove. This heater is made entirely of cast-iron to contain sufficient coal to operate the stove for eighteen hours, and is so constructed as to deliver the coal to be consumed in the proper quantity without waste of fuel.

It is designed to be placed either on the car seat or upon the floor. When placed upon the seat, it is rigidly fixed in position there without cutting the car seat in any way whatever, and when placed on the floor, the addition of a coal box compartment is a part of the stove. The new stove has been severely tested, and its heating qualities thoroughly demonstrated, and the manufacturers state that they will guarantee to heat cars 25 feet in length at a cost not to exceed 10 cents for eighteen hours.

This company has just been appointed general agent for Chicago and the north west, of the R. D. Nuttall Company, of Allegheny, Pa., whose gears, pinions, trolleys and electric railway supplies are in general use on railways throughout the country. The high character of the Nuttall Company's goods is testified to by its many customers. Mr. Myers' wide acquaintance among

the street railway men, and his business methods, will no doubt make him as successful in his new venture as in his original enterprise.

**THE COLUMBIA MAGAZINE CAST IRON STREET CAR HEATER.**

We are pleased to announce that the well known firm, the McGuire Manufacturing Company, Chicago, is about to extend its business, and has added to its specialties the Columbia magazine car heater, herewith represented.

In general, it may be stated that this heater can be placed in any car without marring or cutting the seat for the stove castings. It does not rest upon the seat, cushion or covering, being supported by two legs in

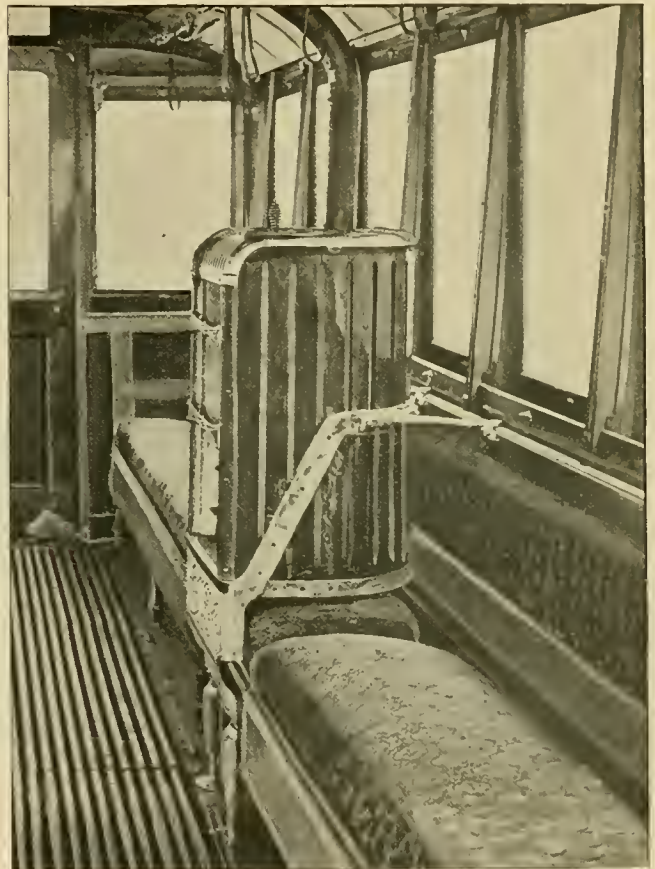

front and by a frame thereto attached. The frame is a solid casting, embracing the front apron, the strap that passes around the back and the arms that fasten it to the top of the seat rail. The legs are adjustable to any desired height. The stove is placed in the car by first arranging the frame and its legs, and then lifting the body of the heater upon it. The operation requires but ten minutes time, and any ordinary mechanic can accomplish it. Once in position it cannot be moved except by the use of tools. It is, altogether, a handsome piece of furniture when thus placed, but if preferred it may be set on any part of the car floor, in which case a stand is used for the foundation. The heater is a self feeder, holding

twelve hours supply of fuel, and, it is claimed, requires no attention from the conductor for this length of time. It burns one pound of hard coal an hour, heating a 21-foot car at the cost of five cents a day. The exterior is so constructed that it remains cool, allowing passengers to sit next to it without danger or inconvenience.

The McGuire Company has purchased the exclusive right to make and sell the Columbian, under patents which have been allowed. With the acknowledged financial strength of the makers and their well known mechanical skill, the new stove will no doubt become very popular among street railway men.

### THE TOWER BRIDGE, LONDON.

We are fortunate in being able to present to our readers, this month, an engraving of the remarkable

bronze wheel claims a record of 1,000 miles and is still running on its patent graphite bearings. The trolley harps made by the company are of bronze, brass, steel, or malleable iron, as desired, and give the best of satisfaction, being light and strong. The Hubley company also makes a specialty of complete overhead equipment and car trimmings of excellent design and finish. The price list and catalogue of all the Hubley specialties will be mailed on application.

THE Card Electric Company, of Mansfield, O., is building double motor equipments as well as single. It is very evident that on small level roads it is useless to weight down a car with double equipments, and for this reason the company advocates the single motor equipment. For roads on which there is heavy traffic, trailers have to be hauled and heavy grades encountered, it



TOWER BRIDGE, LONDON.

Tower Bridge, London, England, recently opened by Wales and approved by his royal mamma.

The bridge is of the bascule type, with two leaves, each weighing 1,000 tons, and the time occupied for opening or closing is two minutes. It will be noticed that at the top of the towers is a connecting foot bridge for pedestrians, and inside the towers run two elevators for the convenience of "bridged" walkers. The leaves are raised and lowered hydraulically, and a 360-horse-power steam plant is required in the operation. The corporation of London built the structure at a cost of £830,005, or roundly, \$4,150,025. We are indebted to London Engineering for the illustration and the data given.

THE Hubley Manufacturing Company, of Lancaster, Pa., reports a first-class trade in trolley wheels, harps and dynamos and motor bearings. The Hubley special

recommends double 20's, 25's or 30's, as the case may require. The Card Company build its motors for high speed for interurban business, and of a medium speed for ordinary traffic.

THE Mather Electric Company, of Manchester, Conn., is making a specialty of direct connected generators for railway work. Until recently, people preferred to use belted machines, but now the direct connected type has been so thoroughly tried that there no longer exists, in the minds of many street railway managers, any doubt as to the superiority of this type over the belted machines. The Mather Company build direct connected machines for both Corliss and high speed engines, from 100 horse-power up. Their new type of railway machine has proven very satisfactory, and a good business is being done by this company in the railway field.



WINDSOR & KENFIELD,

PUBLISHERS AND PROPRIETORS,

269 DEARBORN ST., - - - CHICAGO.

Published on the 15th of each month.

SUBSCRIPTION, - - - TWO DOLLARS.

FOREIGN SUBSCRIPTION, - - - 20 SHILLINGS.

Address all Communications and Remittances to THE STREET RAILWAY REVIEW,  
269 Dearborn Street, Chicago.

H. H. WINDSOR,  
Editor.

F. S. KENFIELD,  
Business Manager.

**CORRESPONDENCE.**

We cordially invite correspondence on all subjects of interest to those engaged in any branch of Street Railway work, and will gratefully appreciate any marked copies of papers or news items our street railway friends may send us, pertaining either to companies or officers. Address:

THE STREET RAILWAY REVIEW.

269 Dearborn Street, Chicago

Eastern Office, Room 14, No. 126 Liberty Street, New York.

This paper member Chicago Publishers' Association.

Entered at the Post Office at Chicago as Second Class Matter.

VOL. 4.

AUGUST 15, 1894.

NO. 8.

THE Supreme Court of Wisconsin has ruled in the "Janesville case" that the city ordinance requiring the electric railway to erect and maintain guard wires where its lines are crossed by telephone wires, is within the province of its powers, and has supported the telephone company in its petition for mandamus. The telephone wires were in place before the trolley wires were strung.

PLATFORM gates are, in almost all cases of operation on double track, a desirable and valuable safe-guard. When once, however, they are placed upon a car, care should be taken to see that they are used, as a passenger alighting from a car through an open gate, and receiving injuries, may be able to strengthen his case in event of damage suit, on account of the failure to keep the gates closed at places and times when they are customarily in use. The best defense in a damage suit is to prevent the accident.

THE Albany, N. Y., Argus, has made a discovery. The fabled Argus had a hundred eyes. We don't know how many the Albany breed has. But this is the discovery:

"A Baltimore man has received a patent for an underground trolley for the propulsion of electric cars."

If any man in Baltimore, white or black, hasn't invented an underground trolley will he please arise and be decorated.

THERE is not the difference between the rate of fare on American and European roads that is commonly supposed, and in addition to this the interesting statement is made that our cities spread out and occupy vastly more territory in proportion to the population than do European cities. For instance, there are, in this country, eleven cities occupying more area than Paris, while there are seventeen cities here which cover more ground than Berlin. The long hauls in this country more than offset the occasional lower fares abroad.

AS THE date approaches for the annual convention of the American Street Railway Association, managers are reminded that they must begin in ample time to arrange their work so as to be able to leave. The trip this year takes us farther south than ever before, and into the very heart of a country full of natural beauty and historic interest. The indications strongly point to a very large attendance, and the well known southern hospitality promised can confidently be counted on in providing every possible means to make the occasion one to be greatly enjoyed and long remembered.

ON a transfer law case at St. Paul, Minn., in which it is alleged that the plaintiff abandoned the car before reaching the transfer point, the court held:

"As stated upon the trial, I am still of the opinion that abandoning the car at a point other than at the intersecting point was the abandonment of a continuous passage; that a regulation requiring the transfer trip to be initiated at the point of intersection was in all respects reasonable and proper, without which, or some equivalent, it would be impossible for defendant company to protect itself from fraud and imposition."

A motion for a new trial was refused and the case now so stands.

AN item originating in some patent inside newspaper office has gone roaming over the country, to the effect that the Amalgamated Association of Street Railway Employes has been successful in every effort during the past year in resisting an attempted reduction in wages. The alleged association has done nothing of the kind, but on the contrary, has been notably successful in a few exhibitions of a want of a very ordinary amount of common sense, and in getting its members in a hole, where they lost good jobs. Dissention and dishonesty among its officers has completed the wreck of what was going to be the salvation of the down-trodden street railway employe, not one of whom could earn as much money at any other honest occupation.

NOR only in Indianapolis and Savannah have the street railway managers voluntarily advanced wages in the last 30 days, but at many other points. Since the fearful financial stringency has been relieved, the managers have, of their own accord, resumed the old scale or an approximation thereunto. The hypercritical daily press has made amusing comments upon this turn of

affairs, but the managers pay as little attention to the compliments as to the former abuse. Even when the papers feel it necessary to offer advice upon every imaginable subject and take a paternal interest in the running of the system, the past has shown and the future will show that the policy of fighting any man or corporation that has a "good thing" is the principal actuating impulse of the editorial pen.

It may be very interesting to compare a few statements of the various Philadelphia papers on the trolley question. The Philadelphia Record was originally a bitter opponent of the electric car. All the venom that pen is capable of was injected in the articles, leaders and news items of that publication. But lo, the change!

On July 11, the Record says editorially:

"The passing of the horse car goes steadily on in Philadelphia, and before the year shall have ended, that vehicle will be as truly obsolete as is the omnibus or the stage coach. Yesterday, the trolley service was inaugurated on the Fourth and Eighth Streets line, and everywhere along the route the advent of the new cars was greeted with demonstrations of satisfaction—a feeling which all Philadelphians may share, since every extension of the system means growth and territorial expansion for the city."

THE Glasgow papers are making a great cackle over the elegant new cars put in service by the city on its now corporation operated street railway, and referring to the rolling stock in use until June 30 last. As a matter of fact the new cars, while comfortable, make no pretense to elegance as interpreted by the American public, and on the lines of one hundred small cities in this country are operating to-day street cars which in construction, finish and comfort, as compared to the new Glasgow cars, are as palace sleepers to ordinary day coaches. With the certainty of confiscation which has hung over the street railway company during the past five years, there can be no surprise that it did not keep pace with the times nor improve its equipment and motive power, as it would gladly have done long ago under conditions prevailing in this country. The new Glasgow broom is in good sweeping order, but 30 days, nor 30 months, may not be sufficient time to bring about conditions which are likely to prove the poor policy of the plan. There can be no question but that the operation of the street car systems of our cities by the municipality would be attended with political and other evils which would be both dangerous and costly to the public.

THE insurance rates on car barns in large cities are getting to be enormous, and although we have freely criticised the underwriters associations for their uncalled for action in regard to grounded 500-volt circuits, we can not blame insurance companies for charging high rates on what actual experience has proved to be a very dangerous class of risks. Cars are from their nature exceedingly combustible. Add to this fact the unfavorable surroundings which prevail in so many car barns and there is an excellent chance for a total destruction of

the property every time a fire occurs. The only way out of the difficulty is to build more in accord with the rules of fireproof construction. In our issue of last March we gave a synopsis of the standard construction and safety precautions specified by insurance companies for power houses, car barns and repair shops. For each item which does not correspond to the standard an additional rate is charged. Thus the designer and builder of a power plant or car barn is able to tell what the insurance rate will be before the building is begun. In other words, it is possible for street railway companies to make their own rates on new buildings. While it is generally impossible to answer all the requirements of the insurance rules, it is easily possible to answer enough of them so that a very low rate can be obtained, to say nothing of the advantages to the railway of increased safety from fires. A saving of from one to six per cent per annum on insurance is worth consideration, and no man should consider himself competent to design a building until he is well acquainted with the requirements of the insurance companies.

CORONER ASHBIDGE, of Philadelphia, has made a statement of the duties of his office for the years of 1892, 1893, and the first half of 1894, touching street railway accidents. The records show thirty-one deaths in 1892, thirty-five in 1893, and twenty-five for the first half of 1894. In 1893 four deaths were chargeable to electric traction, eleven to the cable, and twenty to the horse car. During the first half of 1894 nine deaths are alleged to have been occasioned by the cable and nine by the electric cars. Not one mentioned is reputed to have been caused by the current. The Philadelphia Times says editorially \* \* \* "The special outcry against the trolley seems from the figures to be based upon preconception rather than upon fact. The new cars are still a curiosity. The children are attracted to the street by their very appearance; the more venturesome try to steal rides, while others will place themselves on the tracks in front of the approaching cars, just to see how long they can remain and still escape being run over. With the disappearance of the novelty this spirit of reckless daring on the part of the boys will subside, and there will be more care exercised by them to avoid danger instead of courting it. No one who has experienced the increased comfort and speed of street transit since the introduction of the trolley, would for a moment think of advocating a return to the horse car system, and it is reassuring to know that even the objection of increased danger, which has been so harped upon, has been greatly exaggerated." In the language of the obituary column, "will the Brooklyn papers please copy."

MANY of the light consumers in Lincoln, Neb., have been taking current from the trolley lines. The insurance people are now putting on the thumb screws and will cancel policies. A special agent of the insurance companies, sent to Lincoln to investigate, spent several days, and by dint of sitting up late nights and otherwise



overtaxing his mental and physical system, at last succeeded in avoiding a water haul. He caught a fish, but it was a pretty small fry. And here it is: "The engineer of one of the largest hotels in Lincoln explained to the special agent sent to look into the risks in that town, that bell boys in the hotel were constantly blowing out fuses by short circuiting the wires to see the sparks fly!" This ought to be sufficient warrant to cancel every policy in the state. Suppose, for instance, the power house should shut down for a few hours. Deprived of their accustomed pastime of watching "the sparks fly," they might burn the hotel and court house, and maybe a church or two. The awful appetite of these ferocious bell boys once whetted with a lot of sparks, who knows that they would stop until the entire town was in ashes, and then we might expect the amalgamated bell boys' union would join in the spark business and go on burning until the fair villages of the far west had been laid low in dust and ashes. And why all this? Because, forsooth, the bell boy, as per report of the special agent, is allowed to monkey with light wires, when he should be promptly slippered and sent to bed. For re-distilled and condensed purity of argument, this special agent and his special report on the special bell boys, short circuits our patience.

THE Brooklyn Traction Company, of Brooklyn, N. Y., was assessed by the Board of Assessors upon its personal property or capital stock at \$1,015,000. The company applied to the board to have this reduced, on the ground that its capital stock was invested in the stock of the Atlantic Avenue Railroad Company. This was refused, and the matter brought before the court. Judge Gaynor handed down a decision sustaining the proposition of the company, and compelling the board to review its action and pay the costs of litigation. Judge Gaynor said:

"All lands and personal property, whether owned by corporations or individuals, are alike liable to taxation. The property of a corporation is called its capital. The capital of a corporation is the same as the capital of an individual, and each is subject to the same taxation. It is not the paper certificate of shares of capital in a corporation that are taxed. They merely represent and evidence the distributive portions of the capital or substance of the company, which would go to the different share owners upon the dissolution of the company.

"To tax property and then the paper certificates representing it would be taxing the same property twice. It would be the same as taxing so many acres of land and then taxing the title deeds of it. The Legislature expressly made the 'owner or holder' of the stock in any corporation which is liable to taxation on its capital, not liable to be taxed for such stock (2 R. S., Part 1, Chap. 13, Title 1, Section 7), obviously meaning the paper certificates of the shareholders, and not the proportion of the property, real and personal, of the corporation represented by them, for the title to that is not in the shareholder. The relator, the Brooklyn Traction Company, is the owner of shares of stock in the Atlantic Avenue Railroad Company, and it may no more be taxed upon said shares than may any other owner of shares in the said company."

THE three-wire system for electric railways seems not to have received the attention it has deserved by constructing engineers. There are, we believe, only two systems so operating to-day, one at Portland, Oregon, which Mr. Balch described in our issue of last April, and the one at Bangor, described in this issue by J. G. Carroll. If it has been found possible to keep the balance between the two sides of the circuit in as small a system as that at Bangor, it certainly seems as if there ought to be no trouble where the conditions are much more favorable, as they are on the larger double track roads. When adopted on double-track side-pole construction, and the two wires are made of different polarity, it might be necessary to put a strain insulator or two between the trolley hangers. The section insulators at crossings would have to be made to withstand 1,000 volts. To put over against these objections, we have a saving of 50 per cent in the copper feed wire necessary, leaving out of account the ground return, which would not need to be as good as with the present two-wire system. In addition to this we have the advantage of being almost certain to be free from electrolysis if the system is installed with any degree of common sense. Moreover, we find that the system does not require any changes in the modern power station, except at the switchboard. For carrying the ordinary heavy station load it is now common practice to install three power units of equal size, one of which is held in reserve. With the three-wire system, the two units in service would be switched on to the two sides of the circuit. The liability of shutting down the road through accidents to machinery would be in no way increased. It has been objected that if the cars got bunched on one side of the circuit it would cause a great overload. This is true, but on a large system this is not liable to happen, and when it does, more machines can be thrown in on the overloaded side. The three-wire system is not a good thing for all places, but it has much more of a place than has yet been given it.

It's all in the reporter's eye. "A motorman in Binghamton, N. Y., suffered a distressing accident this morning," says a daily paper. "The flesh of both legs was cut and his pants badly torn." His legs will mend themselves, but the pants will cost money and time to repair.

LITTLE DANNIE FERGUSON is a Brooklyn youth of nine summers. He never had the advantages of a correspondence school of electricity, nor as yet is he an E. E. But he nearly became a D. C., which means a dead corpse, on account of original investigations in electricity. This young martyr to science, in company with some other boys, thought it would be a fine thing to climb a center pole of the Atlantic Avenue Railway. Dannie was first at the top, and grasped boldly at the wire. The connection was only fair, but it took two doctors two hours to bring Dannie back to a realization of circumjacent material objects, and the arms of his tearful parents.

## ELECTRIC POWER ON THE CHICAGO CITY RAILWAY.

The Widest Application of Electric Power Yet Made in Street Railway Work—Inauguration of a Plant that May Radically Change Cable Road Practice—Cables Moved by Electricity.

Before many days, the southern division of the State street cable in this city will be moved with the power given it by an electric motor located in the Fifty-second street cable plant. The source of electric energy will be the electric plant of the same company, located across the alley from the cable plant. If the results are as good as anticipated, and there is every reason to think that they will be, motors will probably replace the steam plants in the other cable stations of the system. This is the boldest move in electrical engineering lines that street railway practice has seen since its beginning. It is, however, perfectly in accord with the advanced policy which has been characteristic of the Chicago City Railway for

many years past. This road was the second in the world to adopt the cable system, and it has always been among the foremost in making improvements which lead to economy or better service. The length of the territory which it covers has necessitated a great economy of operation, and it is safe to say that no system in the United States makes such long hauls for five cents. It also has the longest cable routes in



M. K. BOWEN.

the world, the State street line being  $7\frac{1}{4}$  miles long and the Cottage Grove line nearly 9.

In addition to being a pioneer in cable practice this company has the honor of being the first of Chicago's three great roads to begin the substitution of electricity for horses on its crosstown lines. The recent passage of the ordinances, giving the right to change nearly all the present horse lines of this company to electricity, will result in a system of electric power distribution for railway purposes that for its completeness can not be equaled in this country. The plans of the company here described should be placed to the credit of M. K. Bowen, superintendent, Robert Hill, chief engineer, and G. W. Knox, electrician. These gentlemen hardly need any introduction to REVIEW readers, as Mr. Bowen is well known as a street railway superintendent of long experience, a master of men and of mechanical details as well; Mr. Hill, as the engineer of steam plants which have a world wide reputation for efficiency; and Mr. Knox, as an electrical engineer who knows how to combine science and practice. To these names should be added that of

C. J. Reilly, head engineer of the Fifty-second street electric station, who has made a special study of the possibilities of supplying the power required for all purposes on the entire system from the one electric station.

The idea of supplanting the engines of a cable station with electric motors seems at first absurd, but when the actual conditions are studied, the aspect changes. As shown by the map the company has three cable plants. The one at Twenty-first and State streets, runs all the cables north of Thirty-ninth street. That at Fifty-fifth street and Cottage Grove avenue runs the Cottage Grove avenue cables south of Thirty-ninth street and the Fifty-fifth street branch. The south end of the State street line is run from a plant at Fifty-second and State streets. Across the alley from this latter plant, and fronting on Wabash avenue, is the electric plant which will supply all the electric lines of the company. It has at present machinery for two-fifths its full capacity, or about 2,800 horse-power.



G. W. KNOX.

Some time ago, when Mr. Hill was considering the matter of supplying electric power to the various car barns and doing away with the numerous expensive small steam plants, it suggested itself that if electric power was more economical on a small scale, it ought to be so in a degree on a large. Accordingly the question of supplying the cable plants with electric power was taken under consideration, with the result that an order was placed with the Westinghouse company for a 600-horse-power 500-volt motor, to be placed in the Fifty-second street cable plant. This plant was chosen for the experiment, not only on account of its nearness to the electric plant, but because it is the smallest cable plant of the system and the proportional saving in labor would be greater than in the larger plants. The power has to be transmitted only across the alley. The change from steam to electricity will be made very easily.

The cable plant has two double engines, either one sufficient to carry the load, and belted one to each end of the cable driving shaft. This shaft has couplings at each end for disconnecting either engine. The rim and spokes of one of the engine fly wheels will be removed and the motor placed behind the engine. The belt from motor to cable shaft will pass above and below the engine hub. The other engine will still be on hand for emergencies, and the engine to be replaced could be put in



ROBERT HILL.

running order inside of ten hours. The engine foundation is large enough, so that the motor will not need to have a special foundation built for it but will rest on the engine foundation. The motor, which is 600-horse-power, is identical in construction with the Westinghouse 700-horse-power No. 6 railway generator, except that it is shunt instead of compound wound. It is a six pole machine, and runs at 300 revolutions a minute. Its capacity is 1,044 amperes. It will be started with the aid of an iron wire resistance kept cool by running water.

The average daily load of the cable plant is 250 horse-power. The maximum load (which occurs in the winter at the time of heavy snow storms) is about 600-horse-power. To conduct the current across the alley, copper wires having a sectional area of 1,000,000 circular mils will be installed. This is about the equivalent of five No. 0000 wires.

This will probably be one of the largest, if not the

plant and the oil used, so that Chief-Engineer Hill calculates that \$35 per day will be the total saving in station expenses. The fuel bill of the electric plant will be the only thing that will be increased. The electric plant is now very much underloaded. There will be a saving in fuel during the hours of very light load, when both plants are doing little except overcoming friction. By substituting the motor, the friction of the cable engines will be eliminated, and the saving on this item will for several hours of the day be enough to counterbalance the double transformation of energy.

The loss in transforming the power into electrical energy and back again can not be over 17 per cent (10 per cent in the motor and 7 per cent in the generators), while it may be less. As the fuel bill of the cable plant now averages about \$45 per day, the increased cost of fuel would be 17 per cent of this, or \$7.65 a day, to put against a saving of \$35 on the other items. The cable

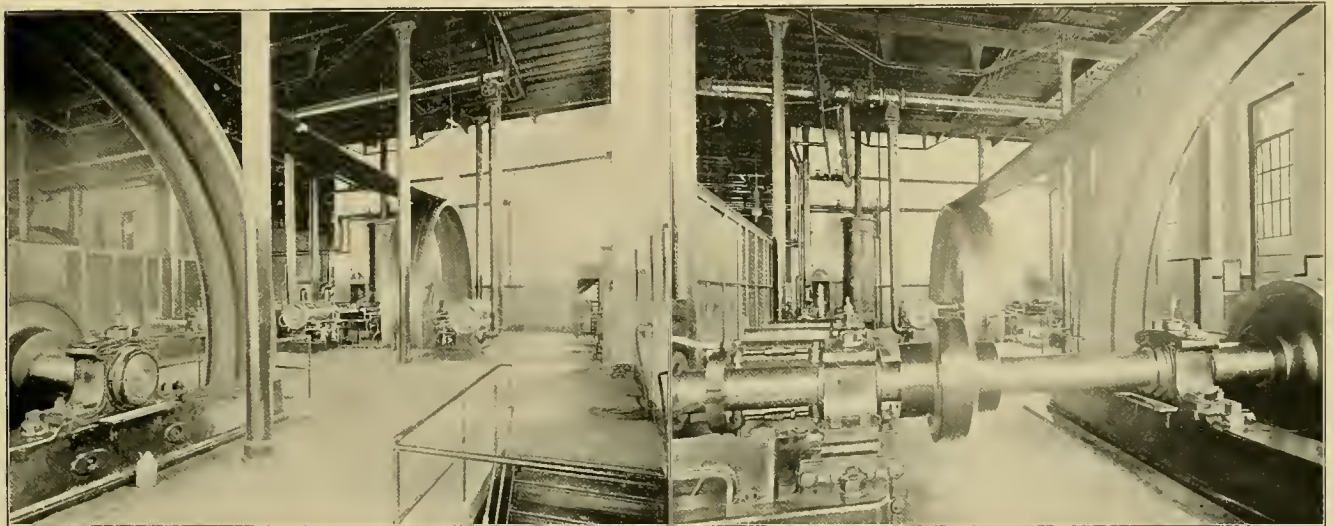

VIEWS OF CABLE ENGINE TO BE REPLACED BY ELECTRIC MOTOR.

largest electric motor running in the world, but there is no reason to believe that it will not do its work exactly as expected by its installers. It will be shunt instead of compound wound, because shunt winding is the simpler and will keep the speed within a two per cent variation, which is as near as the steam engines now keep it.

The use of this motor will offer a splendid opportunity to study the variations of power required by the cable.

It will also be possible to tell much more closely than ever before the per cent of power required to move the cable without cars. The difficulties of taking engine indicator cards quickly has always been in the way of studying closely the performance of cable machinery, but this difficulty will disappear when an ammeter is substituted for the indicator.

The saving in labor alone due to the change will amount to \$28 per day. The electric plant will require no additional force, while that in the cable plant can be cut down enough to make the saving mentioned. To this saving must be added the repairs on the cable steam

load is more steady than that on the electric lines, and it is thought will help to make the performance of the electric station steam plant even better than its present excellent showing, a record of which will be found in the STREET RAILWAY REVIEW of November, 1893. A horse-power hour is generated with  $3\frac{3}{4}$  pounds of screenings, at \$1.50 per ton.

If the experiment is successful, the next cable plant to abandon the direct use of steam will be that at Cottage Grove avenue and Fifty-fifth street. The average load on this station is 750 horse-power, and in case electric motors are installed, two of 1,000 horse-power will be used. The distance from this to the electric power plant is about  $1\frac{1}{4}$  miles, and as it will require the equivalent of fifty-one Number 0000 wires to carry the necessary current this distance, with the proposed 25-volts drop, the conductors will, of course, have to go underground. About half of the distance from one station to the other is over Washington park, so that underground work will not be as expensive as if otherwise. There is the fur-

# Street Railway Review

ther possibility that in time the Twenty-first street plant will be run by electricity, but as it is over  $3\frac{1}{2}$  miles from the electric station, and is very large, having an average load of 1,000 horse-power, the advantages of the change would be greatly reduced.

Along with the extensions of the various electric lines will come the application of the railway current to the lighting and power supply of all the barns. Besides the

the other load is lightest and when it can be most conveniently taken care of.

The new electric lines, when completed, will comprise in all 130 miles of road, and it is calculated that 300 motor cars will ultimately be needed. The territory covered by the system and its relation to the electric station can be best seen by the accompanying map.

The electric station, which should be visited by every

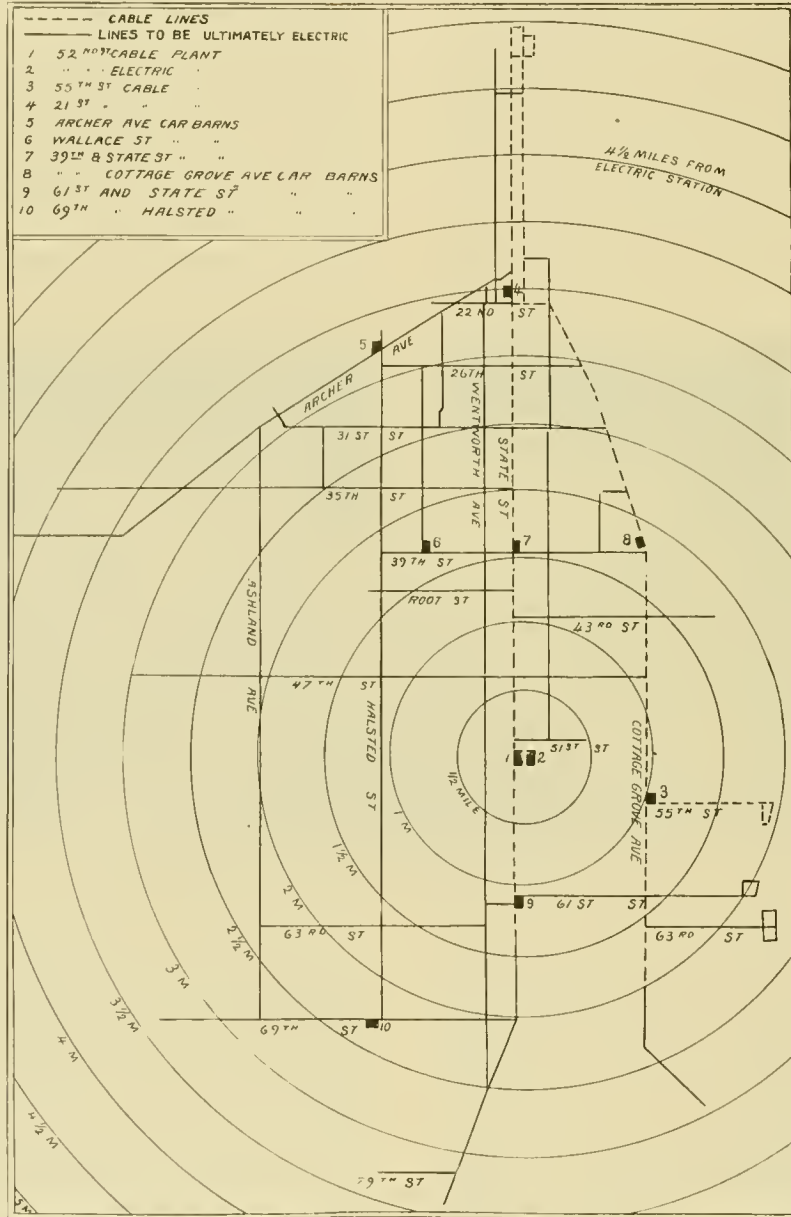

MAP OF CHICAGO CITY RAILWAY SYSTEM.

repair shop at State and Twenty-first streets, there are six barns. At five of these there are from one to four car elevators. In all there are eleven elevators. Two 50-horse-power motors will be installed for each elevator. At present, steam engines are in use at the barns, each running several hundred feet of line shafting. The expensiveness of small steam plants is well known, and the aggregate saving along this line will be considerable. The lighting and power load will come at a time when

electric railway man coming to Chicago, is a model of neatness and good engineering. It is a station in which no extravagant expenditures have been made, but it has always been the policy of the City Railway management to omit nothing which will add to the economy and reliability of its plants. The station is a one story building, 35 feet high and 130 by 147 feet. The boiler room is 57 by 130 feet and has space for 14 Mohr water tube boilers, one-half of which are now in place. The coal is

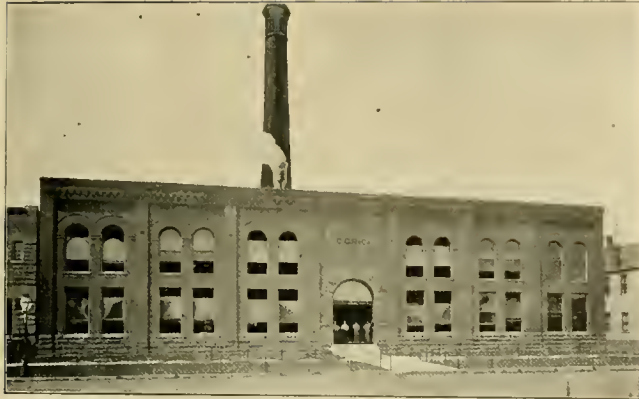

EXTERIOR OF ELECTRIC STATION.

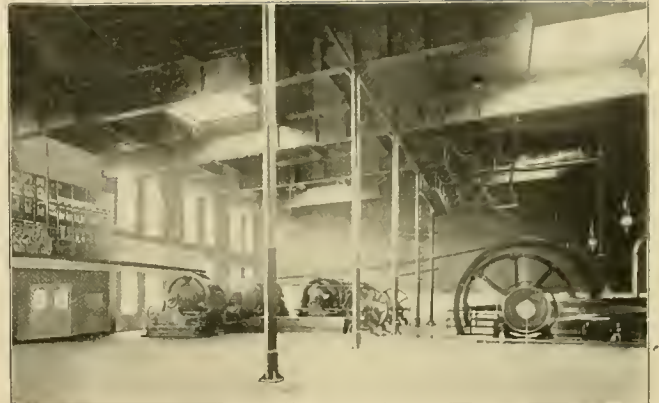

INTERIOR OF ELECTRIC STATION.

delivered in the cable plant across the alley, at which place it is loaded into dump cars and lifted to an elevated tramway, which crosses the alley and runs above the boilers of the electric plant, where it is dumped into the bins or hoppers feeding the mechanical stokers. The engine room has space for five units, of which two are installed. Each unit consists of a pair of Wheelock, simple engines, connected by a Hoadley rope drive to a jack shaft. On each end of this shaft is a clutch for throwing in a 700-horse-power Westinghouse four-pole generator. The ultimate capacity of the station is thus 7,000-horse-power, which is ample to drive the whole system, cables and all, if it is decided to do so. The switchboard bus bars are calculated for 10,000 amperes. The switchboard is the Westinghouse standard, but ammeters will be put in the feeder circuits when more machinery is put in. The plant gives employment to 20 men, whose work is divided into three shifts. The usual force at any one time is three in the coal room and four in the engine room. The oil bill of the station is very low, not exceeding \$5 per month. Cylinder oil is used throughout—first on the bearings and then in the cylinders. For feeding the boilers, an exhaust injector is used the greater part of the time. The station is well suited to become the “heart” of a great street railway system. The apparatus and its arrangement has given so nearly perfect satisfaction that there is little reason for a change of plans in enlarging the station. Mr. Hill’s stations are always well planned and well

taken care of. If more electric railway stations were as well planned and cared for, the standard of street railway power plants would be materially raised. The visitor to this station can hardly realize that he is in a power plant. Everything is as neat and clean as a parlor and the Wabash avenue front has a well kept lawn.

Simplicity, uniformity and cleanliness are the rules throughout the plant and nothing that is out of order is allowed to remain so long. The company keeps a wrecking gang of six men who are experts in repairing and overhauling heavy machinery. They are employed among the several plants before mentioned and all troubles receive immediate attention.

It is Mr. Hill’s idea that this arrangement of driving several cable plants from one electric station can be used to great advantage when, as in several cities the grades are too steep to be practicable or economical for electric traction, and where several separate small cable plants have to be maintained. A great saving could be effected by having but one steam plant and running the cables by electric motors, which require very little attendance or space. If the road operates both electric and cable lines

the advantage is still more pronounced. The entire street railway world will be deeply interested in this radical and unique departure of the City Railway, and awaits with interest the further details.

THE Chicago City Railway Company will open bids on electrical equipment for its new lines, August 28.

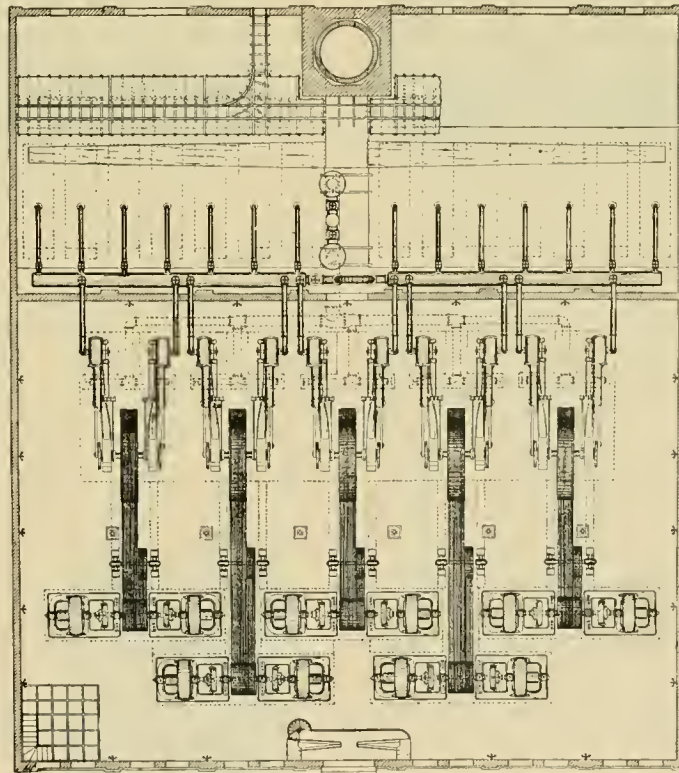

PLAN OF ELECTRIC STATION.

## ELECTRIC RAILWAY WORK IN CHICAGO.

As noted in the two last two issues of the REVIEW, Chicago is destined to have within its confines several hundred miles of electric railway lines, and to be one of the great electric railway centers of the world. The cable has borne a noble part in the matter of Chicago's rapid development, but now, outlying districts less thickly populated are to be served by the electric current, and the buzz of the trolley is to be heard far and wide—north, west and south.

To begin with, the North Halsted street line is in operation and North Shore cars connect with the cable. The North and West Chicago electric lines are being ably directed by John R. Chapman, formerly of Grand Rapids, Mich., who has temporary offices at 544 North Clark

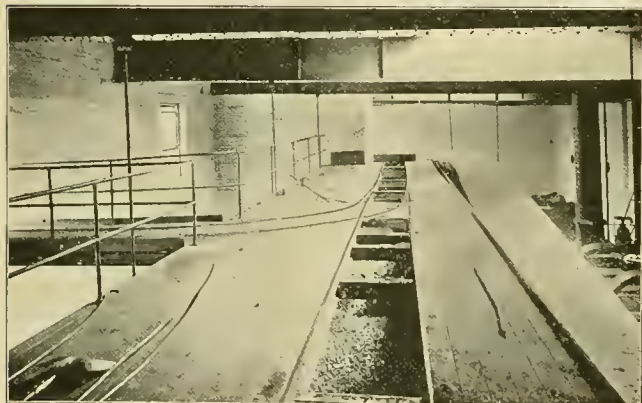

ABOVE THE COAL BINS—ELECTRIC STATION CHICAGO CITY RAILWAY.

street. Mr. Chapman says that the railroad tie up has done great harm to progress on his lines, delaying not only the rails and poles expected, but the engines as well, so that affairs are almost at a stand still. The delay gives time, however, for the close study and calculation of feeder systems and consideration of supplies. On Milwaukee, Lincoln and Elston avenues, rails have been bonded and wire strung, but it is doubtful if cars will be run for several months. Larrabee, Sedgwick and other streets are in statu quo, waiting for supplies. Fifteen miles of the Milwaukee avenue and Lincoln avenue lines will be operated from the North Shore power house. The location of the new power house for the remaining lines will be on Roscoe, at the river. The West Side lines are hardly begun, but fifty-nine miles of double track are to be operated. Van Buren street is the most important of these lines permitted to use the trolley. Engineer S. Potis and his corps have their hands full of plans for power houses and line work for the west and northwest lines.

The West Side power house at Washington boulevard and Western avenue will ultimately accommodate five 2,000 and one 1,000-horse-power generators. The Roscoe power house of the North Side lines will call for 2,800 horse-power of generators. Siemens-Halske direct connected will be used. This power house will operate

all North Chicago lines and all West Chicago lines north of North avenue.

## CHICAGO CITY.

The city council, after a painful delay, has finally granted the Chicago City Railway, rights for electric lines on numerous streets, and preparations are in progress to begin the beginning of these important additions to rapid transit service. The Chicago city ordinance calls for lines on Twenty-sixth, Thirty-first, Thirty-ninth, Fifty-first, Sixty-ninth, Seventy-ninth streets, Archer avenue from the river to Thirty-eighth street, thence on Thirty-eighth street to the terminus; Forty-third street from the Illinois Central tracks to State street, thence to Root street and thence to the terminus; Halsted street, Wentworth avenue and Ashland avenue, from Archer avenue to the termini; Hanover, Butler and Wallace streets, where tracks are now laid; State street from Sixty-third to Vincennes avenue, thence on Vincennes avenue to the terminus. The special ordinance covers Sixty-third street from Cottage Grove avenue to State street; Wallace street from Thirty-ninth to Root; Halsted street from Sixty-ninth to Summit, thence on Summit to Eighty-seventh; Center avenue from Forty-seventh to Sixty-third; also, permission to lay a conduit in Twenty-first street from State street to Cottage Grove avenue. The company has qualified and the Halsted street line is now under reconstruction. Bids have been asked for all the material to be required in the reconstruction of the lines. These will be opened August 28 and will be decided soon. Construction will then go on immediately.

## SOUTH CAROLINA, WHERE THE POLES COME FROM.

W. F. Murphy, E. E., and J. H. Bruning, M. E., are two enterprising young men, who live in Charleston, S. C., and make excellent use of the great wealth of timber which this region affords, by giving to the street railway men of the country excellent pole material. The por-



J. H. BRUNING.



W. F. MURPHY.

traits of the two gentlemen are given herewith, and their field of operation shown in the view of the magnificent forests.

Exceptional shipping facilities are afforded for the transferring of the product, by reason of the situation of the city of Charleston on the seaboard and at the conflu-

ence of the Cooper and the Ashley rivers. Charleston itself has 60,000 inhabitants and is an important port.

The two rivers mentioned flow through a remarkably rich timber region and their shores are lined for miles with immense forests of long leaf pine and with cedar. Besides this an inexhaustible supply of oak and cypress comes from the Santee swamp, a vast area, lying 50 miles from Charleston. The life of cypress timber is much longer than that of cedar and it is free from knots



SCENE IN THE SANTEE SWAMPS.

and of great strength, at the same time being very rigid. It will be readily seen that with such a supply of desirable timber and such good shipping facilities for all northern points, that South Carolina timber may soon be as well known in street railway work as it is in numerous other branches of industry.

The firm of Murphy & Bruning is thoroughly alive to the needs of the street railway fraternity.

L. S. BOOMER, 647 Rookery, Chicago, has taken the Chicago agency for the Ellis Manufacturing Company.

If you are going to the Atlanta convention it is well to arrange sleeping car space. The Big Four and the Queen & Crescent routes are the popular ones out of Chicago. That's the way the crowd will go. Write J. C. Tucker, 234 Clark street, Chicago, for sleeping car berths.

CHAS. COOPER, of C. & G. Cooper & Company, the well-known engine builders of Mt. Vernon, O., mourns the loss of his wife who died last month. On July 27 his only son and child died at the Thousand Islands, whither he had gone to make a short visit on his way home from college. All the many friends of Mr. Cooper sympathize with him in these two sad bereavements.

W. J. COOK, of the McGuire Manufacturing Company, reports matters flourishing and a shop full of orders. A recent feature of the business that is pleasing to the company, was an unsolicited order for 50 trucks from a well-known eastern road now using a large number of McGuire trucks on two previous orders. The company has now 500 trucks in hand or to be delivered within the near future.

THE Siemens & Halske Electric Company has erected large direct coupled railroad generators for use in the United States and Canada, as follows: Garden City Construction Company, (North Chicago lines), four of 620 horse-power; West Chicago Street Railroad, three of 2,000 horse-power and one of 1,000; Nassau Electric Railway, of Brooklyn, N. Y., three of 667 horse-power; Toronto Street Railway, two of 1,400 horse-power; City Railway, Dayton, O., three of 400 horse-power; Ringing Rocks Street Railway, of Pottstown, Pa., two of 135 horse-power; Cincinnati Street Railway, one of 650 horse-power.

THE Southern Railway Company, the Piedmont air line, runs elegantly equipped trains with sleeping and dining cars through to Atlanta and New Orleans every day in the year. With quick time and elegant equipment, it offers to street railway men of the east a direct and pleasant trip to the Atlanta convention next October. On October 15 it will run an elegantly equipped vestibuled special from New York, touching Washington, Baltimore and points south. R. D. Carpenter, 271 Broadway, New York, F. B. Price, 32 South Third street, Philadelphia, L. S. Brown, Washington, and G. R. Needham, 106 E. German street, Baltimore, will furnish information and rates.

THE Kuhlman Car Company, Cleveland, O., is finishing seven cars for the Berea Street Railway. They are 28-foot, closed bodies, with cross seats. All are finished in mahogany, vestibuled and equipped with Stanwood steps and Dorner & Dutton improved trucks. Fulton Foundry patent draw bars are used. They are elegant specimens of the car builder's art and fully up to the well-known high standard of the Kuhlman works. The Kuhlman Company has just received an order for seven cars for the Cleveland Electric Railway Company. These will be 32 feet long, closed bodies, with doors at the ends next to the outside steps, and also provided with side doors, wide aisles and doors on the side of the car. These cars will also have cross seats, vestibuled in front.

A. E. BAKER, the bright young assistant secretary of the Baltimore Car Wheel Company, writes us from Charleroi, Belgium, that his European trip has been a combination of business and pleasure and that his second month on the continent has been very profitable. He will return about September 1. Mr. Baker is thoroughly alive to every detail of his chosen work, as well as to the more æsthetic incident of foreign travel.

## HALF FARES.

Interesting Bits of Information from All Parts of the Country,  
Boiled Down for Busy Readers.

THE Technic Electrical Works of Philadelphia have put upon the market an improved rail bond.

WHILE a scow loaded with 125 tons of rail for the new Perrysburg electric railway was being unloaded it sank with nearly its entire load.

IT is reported by the Detroit, Mich., News, that Detroit has 10,000 bicycles, which knock out 20,000 street railway fares every fine day.

ENSIGN BROWN, late counsel for the Youngstown, O., Street Railway Company, was arrested July 27 by Manager Anderson, who alleges embezzlement.

MILWAUKEE'S coroner found that June deaths by accident fall under the following heads: Drowned, 23; suicides, 6; street railway accidents, 2; total, 31.

AT Paterson, N. J., a "street car party" was recently run into by a steam train on the Paterson Railway Company's tracks. No one was seriously injured.

SEVERAL classes of the National School of Electricity have been organized among the motormen and shop men of the street railway companies in some cities.

JUNE 9, the Evanston line of the North Chicago Street Railroad Company was first operated by electricity from Clark street limits to the North Shore southern terminus.

DURING the late strike the Twin City Rapid Transit Company, of Minneapolis and St. Paul, was compelled to use cord wood, no oil, which is the ordinary fuel, being obtainable.

THE South Chicago City Railway is using oil fuel, and Superintendent W. A. Rowe reports it cheaper than coal, even when coal is at ordinary low prices. The station is located near a pipe line.

THE awful effects of the Brooklyn trolley has the last straw added to it by the New York Journal, which says: "All the back alleys in Brooklyn will soon have trolley lines in them, and the clothes lines and the tom cats will have to go."

THE Lincoln Street Railway Company, of Lincoln, Neb., gets \$42.75 per mile per year for carrying mails, and, as nearly as possible, twenty miles are in this service, the revenue from this source is nearly \$900 a year. The postoffice department wants the service extended.

THE Atchison, Kan., Globe, is getting a national reputation for its bright paragraphs. One recently read as

follows: "When the last rail of the Atchison electrical street railway is laid, a golden spike valued at \$80 will be driven, with appropriate ceremonies. But it will not be pulled out as soon as the crowd disappears as was done in Leavenworth. It will be left there, and the first man to claim it may have it. That's the sort of town Atchison is.

THEY have to pay for it now in Blankville. At least the Blankville Blinker says:

"After ten o'clock in the evening, when the street Car Co. has to keep extra cars and men out late at night, after dances, theaters, etc., the street car fare will be ten cents."

A FEW sympathisers of the Chicago strikers have refused to ride in the Tiffin, O., Electric Street Railway Company's double-decked car, because it was made by the Pullman Company, but the car still runs, and Mr. Pullman up to date has not signified his sorrow at the insult to the company's car.

A PLUCKY young woman recently kept her head during a street railway grade runaway at Alliance, O., and saved the lives of the passengers. Her name is Rena Conn, a book-keeper. The motorman when he found his car going down hill at too great speed immediately lost his nerve and deserted his post. Then Miss Conn jumped to the brake, told the passengers to keep quiet, and saved the day and the car. She is the heroine of the hour and rightfully so.

PLANS for the Hestonville, Mantua & Fairmount Passenger Railway Company are prepared. The building will be in the style of the Italian Renaissance. The ground dimensions are 113x150 feet. The main front, on Callowhill street, will be of Hummelstown brown stone base and Pompeian brick, with red Maynard sandstone and terra cotta trimmings above. The smoke stack will be 160 feet high. The entire structure will be of fireproof materials, and will contain four Green-Corliss engines of 1,000 horse-power, and four batteries of Babcock & Wilcox boilers. It is intended to use only three engines and three batteries of boilers at present, keeping one set in reserve. The cost is placed, with machinery, at \$250,000.

IF, from statistics, an equation could be framed, it would be found that human life is held in highest estimate in France, followed by the eastern part of the United States, England, Germany, Holland, Ireland and Norway, in the order named. The ratios of accidental deaths to the 10,000, from all causes, are as follows: England and Scotland, 30; Ireland, 18; France, 15; Germany, 16; Russia, 6; Austria, 10; Italy, 5; Switzerland, 28; Spain, 7; Denmark, 12; the United States, 40. The United States has the smallest number of homicides and suicides in proportion to its population, which brings down the equation premised in this note. Familiarity with new systems of traction, manufacture, etc., reduces that death rate from these causes very rapidly.



PERSONALS.

THOMAS M. SAYRE, superintendent of the Consolidated Traction Company, of Jersey City, N. J., died recently.

CLARENCE CHASE, of Kansas City, Mo., has accepted the secretaryship of the Mobile, Ala., Electric Railway Company.

JOHN E. McVEY, has been elected secretary of the Youngstown, O., Street Railway Company. Mr. McVey is a prominent attorney.

E. P. Shaw, Jr., has been made manager of the Pawcatuck Valley Railway Company. He has appointed H. W. Tracy superintendent.

F. A. SOULE, so well known to Chicagoans through his connection with the Jefferson & Urban Rapid Transit franchise of last year, is dead.

JILSON J. COLEMAN, general manager of the Lehigh, Pa., Traction Company, owned by the Johnsons, has been transferred to the Johnson lines in Brooklyn.

RUSSELL B. HARRISON, of Terre Haute, Ind., the enterprising and thoroughly alive president of the street railway company, paid the REVIEW a call recently.

WM. RAMSEY, general superintendent of the Federal Street & Pleasant Valley Passenger Railway Company of Allegheny, Pa., is in southern California for his health.

THE new superintendent of the Newark, N. J., Traction Company, is J. L. Quigg, formerly superintendent of the western division of the New York & New England Railroad.

LEO DAFT, the well-known electrical and mechanical engineer of the state of Washington, recently took a trip up Mount Ranier, where he spent 26 hours at an altitude of 14,400 feet.

WILLIAM J. RICHARDSON has resigned the secretaryship of the Atlantic Avenue Railway Company and has gone to Europe with his family. He will attend the International Street Railway Association at Cologne.

CHIEF ENGINEER POWERS, of the Elkhart-Goshen, Ind., street railway, has been made superintendent of the line. President Burns has bought General Electric generators and a Bates Machine Company's engine from Joliet, Ill.

B. F. HARRIS, Jr., president of the Urbana and Champaign, Ill., Street Railway Company, was a recent caller. Mr. Harris' brilliant success in his street railway business leads one to suppose him at least 40 years of age, but he isn't.

HENRY G. ISSERTEL, E. E., is located at 39-41 Cortlandt street, New York City, representing the H. W. Johns Manufacturing Company, the Bernstein Electric

Company and the Iona Manufacturing Company, Boston. Mr. Issertel was formerly the manager of the Railway department of Alexander, Barney & Chapin. His many friends wish him the best of fortune in his new connection.

A NEW GAME.

What the ordinary American youth will not think of is not worth the while of any one to cogitate upon. The cable system furnishes him endless amusement when he attaches tin cans, cats or puppy dogs to the endless rope and watches the unfortunate beasts in their mad gallop against time. The electric railway gives full play to his energetic researches in applied electricity, and horse cars are useful in many ways as modes of surreptitious conveyance. Besides the horses may be scared by fire-crackers and torpedoes.

The safety fender is the latest addition to his list of playthings, and the various inventors of successful fenders do not know the joy of the gamin's heart as he finds use for this article.

In the center of the city is where they get the most fun out of this new game. Here the cars move slowly and they can easily step upon the guard and squat down out of reach of the motorman. It is the fact that they are practically out of reach, yet actually in danger, that makes this new sport particularly attractive to the boy, and particularly aggravating to the motorman. The motorman's life becomes even more of a burden with the fender than without, and the agile street arabs need no coaching as to the best methods of making the driver's misery profound.

THE Big Four will take many delegates to the Atlanta convention as far as Cincinnati, where all streams will join in the river of delegates that will take the Q. & C. route.

ONE OF MANY.—As he settled himself in the car his face turned ashen gray, a choking sound came from his throat, and with a shout of "Stop the car! Stop the car! For the love of Moses, stop the car!" he bolted into the street, knocked over a newsboy, eluded the grasp of several bystanders and ran plump into a policeman's arms. "What d'ye mane by this," growled the officer of the law, as the crowd began to gather about the agitated man. "Are yez crazy or drunk, or been stalin' something? I think I'll run yez in just for luck." The pale face of the hunted one grew paler as he gasped: "Don't do that, officer, if you want my veneration and prayers; I've forgot to get Mary's curling irons and the store shuts in five minutes;" and the policeman, who was a married man, dropped his grasp and said, "Poor fellow."

Street Car Passenger—"I have paid my fare."

Conductor—"I don't recollect it."

Passenger—"And you won't re-collect it, either."

## SIEMENS-HALSKE FACTORY AT CHICAGO BURNS.

The heaviest fire loss known in the annals of electric manufacturing, occurred on the night of August 1, when the magnificent plant of the Siemens-Halske Company of America was completely destroyed, entailing a net loss of \$350,000. This fine manufactory was situated in the "lumber district" of Chicago, on the corner of Blue Island avenue and Wood street. About six o'clock p. m.

of glazed marble and slate and fused wire. The works ordinarily employed about 2,500 men in all departments, and even during the slack time gave work to 500 or 600 mechanics.

The small engraving upon page 465 shows the remains of the Lake Erie 250-horse-power vertical engine, which was direct coupled to dynamos of a similar capacity. To the left is a 150-horse-power Williams engine, belted to a Siemens-Halske dynamo. Just back of the Erie engine and to the left, may be seen the ruin of a very elaborate

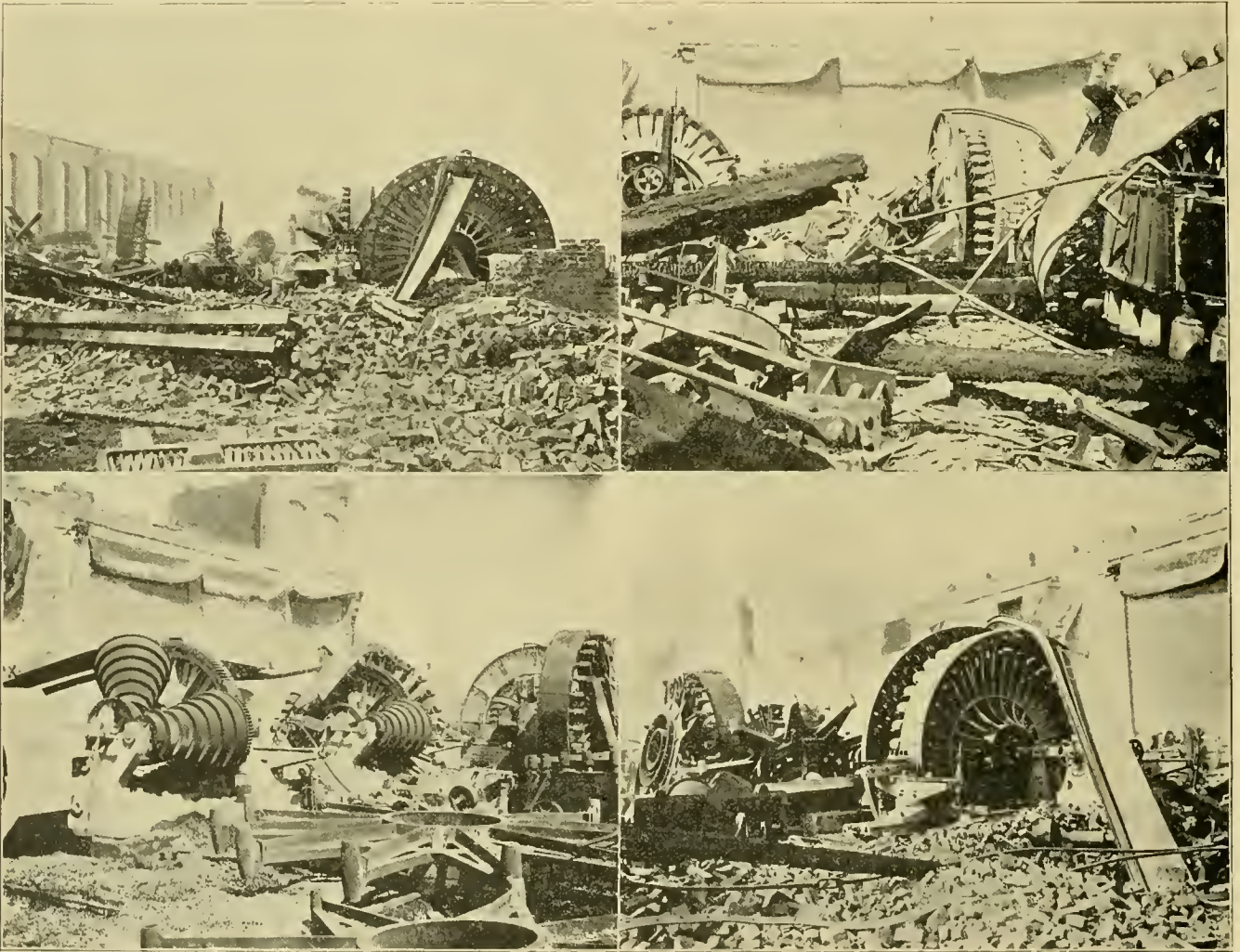

VIEWS OF INTERIOR OF SIEMENS HALSKE FACTORY AFTER THE GREAT FIRE.

the fire started in the heart of the lumber yards, and by nine o'clock the reflection on the clouds heralded the destruction of \$2,000,000 worth of property. The magnificent city fire department, fire boats and all, was powerless, except as it could restrain the flames from adjacent property.

Before morning the great brick structure, which contained the expensive manufacturing machinery of the Siemens-Halske, as well as many thousands of dollars worth of goods in various stages of completion, were totally destroyed, as our engravings show more eloquently than words. The large work for Brooklyn, Toronto, and other street railway plants was reduced to a mass

switch board, designed by the company to illustrate their 2, 3, and 5 wire systems. It was used practically for electric light, but was placed to illustrate power use as well. It cost \$4,000. In the foreground may be seen the ruins of two 150-horse-power Ide engines, which had been set up for the purpose of directly connecting dynamos to drive the Chicago General Street Railway.

The REVIEW's special artist obtained also views of the shops, four of which are grouped in the large engraving. The upper pair displays the large dynamos, almost ready for shipment to Toronto. The right hand view shows one Toronto dynamo, or rather the ruins, ready for shipment, and to the back its brother, still on the big lathe.

The left hand view shows next the wall the Metropolitan dynamo, and to the right another view of the Toronto dynamo. In the background is a dismantled Morgan traveling crane. The two lower views are from photo-

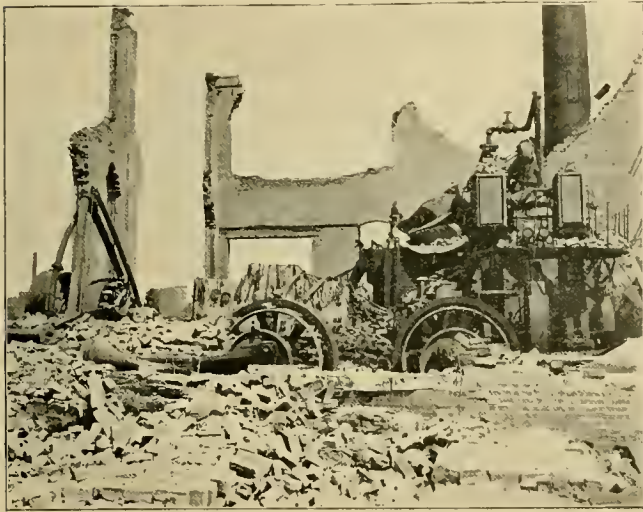

REMAINS OF ENGINES—GREAT SIEMENS-HALSKE FIRE.

graphs, showing side elevations of the Toronto dynamos and a better view of the lathe, said to have been the largest in this country. The total value of the plant is placed at \$500,000, and the insurance amounted to \$150,000.

The double engraving shows another victim of the great fire, the foundry of the Wells-French Company. The loss on this was about \$100,000, well insured. The cupolas stand grim and lonely in the background. They were used to heat, and a little thing like the present fire did not hurt them. The completed wheels are shown in the foreground.

The day following the fire, the Siemens-Halske Company began operations in the Wells-French shops, and is ready to get out work and receive orders as usual. The company will at once occupy the Grant Locomotive Works plant.

ANOTHER FIRE AT PEORIA, ILL.

Peoria, Ill., is a chronic sufferer from street railway fires. The last one, on July 27, licked up the West Bluff barn of the Central Railway Company, together with thirty old cars, and smacked its lips for more. The loss was about three thousand dollars; well insured. This fire, as well as several other Peoria blazes recently, are thought to be the work of incendiaries.

At Newark, N. J., on July 27, the Bloomfield car barns of the Consolidated Traction Company burned. The loss was \$40,000. Six horse cars were burned and thirty saved. The building was eighteen years old and covered one and a half acres of ground.

WHITE-CROSBY'S PRIZE.

The prizes offered by the White-Crosby Company, of Baltimore, for car barn plans, have been awarded as follows:

- First prize, \$100, to M. D. Pratt, Engineer, Pennsylvania Steel Company, Steelton, Pa.
- Second prize, \$50, to D. B. Banks, Engineer, Baltimore Traction Company, Baltimore, Md.
- Third prize, \$25, to J. H. Bickford, Salem, Mass.
- Fourth prize, \$5, to F. J. Tone, Pittsburg, Pa.
- Fifth prize, \$5, to William P. Anderson, Baltimore, Md.
- Sixth prize, \$5, to W. Nelson Smith, New Orleans, La.
- Seventh prize, \$5, to A. S. Krotz, Springfield, Ohio.
- Eighth prize, \$5, to J. S. Hill, Lafayette Ind.

The J. H. Bickford plans were given third place on general merit, the design submitted by him being for a much larger car barn than the one called for.

A FUNERAL CAR COMPANY.

A new company in Buffalo has been organized to institute a new cemetery of 200 acres. Adjacent land will be made into a park with street railway connections. A funeral car will be run to the cemetery. Chas. F. Molly, of Bethlehem, Pa., is president, and T. O. Frierson is general manager of the company.

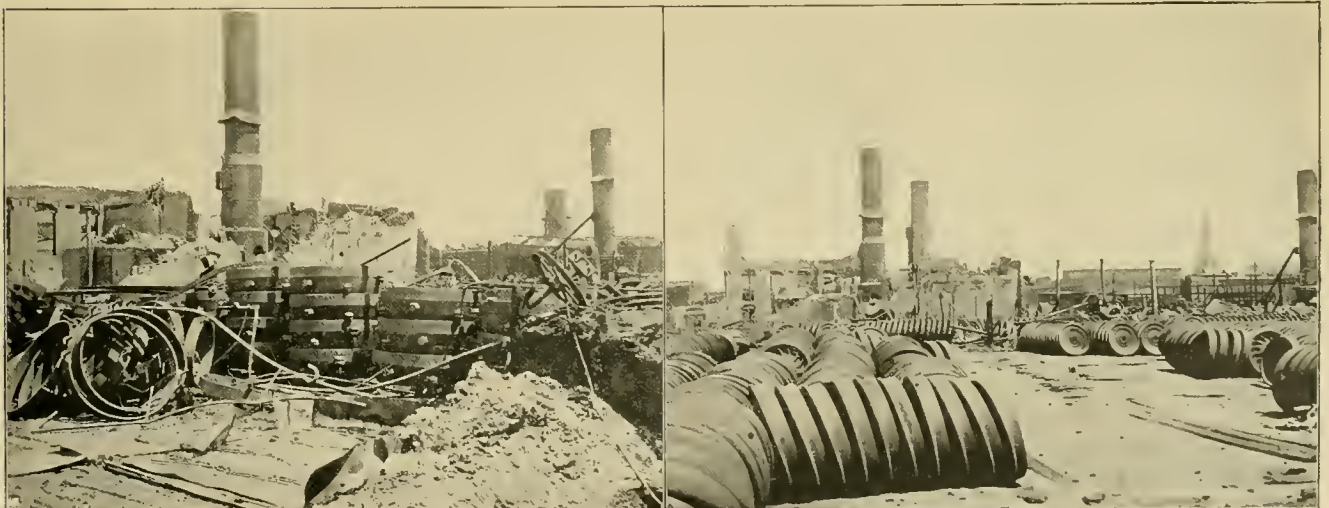

RUINS OF THE WELLS-FRENCH FOUNDRY.

## ELECTRIC CAR HEATING.

BY W. S. HADAWAY, JR.

There are many theoretical and practical considerations upon which electric car heating by electricity may be urged. Questions of economy are not the only considerations in the car heating problem, but sanitary reasons as well.

The price of electricity varies greatly in different localities, according to the size of the road, cost of coal, labor, etc., so that figures obtained from the cost of operating one road cannot be used in figuring the cost of heating by electricity in general. The only fair basis of comparison is from average figures, and not extreme figures. It has been found in actual practice, this practice including several hundred cars, that 100 watts are sufficient to warm 30 cubic feet of space in an average well built twenty foot car, having from 100 to 125 square feet glass area and a monitor roof with windows of moderate tight-

vection from one point only, as the space to be heated is comparatively large, a small boiler can be successfully employed, distributing the heat through pipes, by either steam or hot water, but preferably the latter. The relatively small size of the car, however, permits the use of stoves or heat storage systems, and these, consequently, have been largely resorted to.

There are two forms of electric heaters by which an equable distribution of heat can be effected. First: By radiation from a heated surface in which convection currents enter to some degree. Second: By direct air heaters or registers in which little or no radiating surface is offered, the hot air arising from the heater and setting up air currents which circulate about and thus distribute the heat.

The forms of electric car heaters so far proposed are heaters by simple resistance, so that the form of heater to be chosen is dependent upon its durability, first cost and manner of distributing heat throughout the car. During the past winter the opportunity was again taken

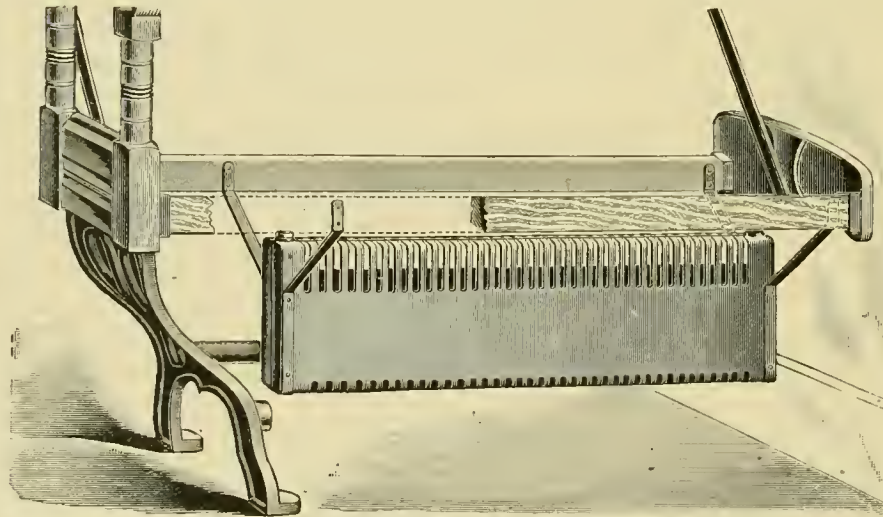

HEATER ADAPTED TO CROSS SEAT CAR.

ness. This value does not apply to extreme northern latitudes and is a representative value for the southern New England and central states. The value for the northern latitudes can be computed from the foregoing figures by comparing the weather extremes in the two cases.

Carrying out the value given in the preceding paragraph, we find that in a twenty foot car in latitudes stated, 3,000 watt hours, or 4 horse-power hours, sufficient to allow for weather extremes; and the average running value will be determined by the severity of the season, exposure to winds, average running speeds and what may be generally termed local conditions. The practical application of heating in cars is substantially the same problem as offered in conservatory heating, with the disadvantages of the car in motion and many loose fitting windows and doors, and the advantage of a considerably decreased proportionate glass area. In practice, no competent heat engineer would attempt to heat a conservatory by distributing the heat by direct radiation or con-

advantage of to make an exhaustive study of electric heaters in actual use on cars equipped by the Central Electric Heating Company, of New York, and the New England Electric Heating Company, of Boston, and valuable data was obtained. These tests were with a thermometer on the front end of the car and one on the rear end of the car, each about 5 feet 6 inches from the platform floor. The inside temperatures were obtained by placing one thermometer on the inside of the front end and one on the inside of the rear end, and two thermometers on opposite sides, but equi-distant between the two ends. These two intermediate thermometers were varied in position, being attached part of the time to the window frames and part of the time to the straps and at a height to which persons of average size would feel the temperature most keenly, viz., at the back of the neck. These tests were carried on with heaters of four distributing points and of six distributing points, and of radiating surface distributed uniformly throughout the length of the car. It was found that the electric

heaters successfully warmed all portions of the car, and that the distribution of warm air was far superior to the distribution attained in cars heated by stoves which were run on neighboring lines. There is no doubt that the popular verdict is very strongly in favor of the electric heater.

As regards the bare cost of operation, every railway

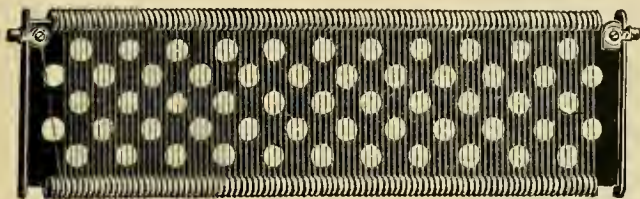

manager can figure for himself on the data given. A case in point of a road figuring its power at \$2.00 per horse-power per month, shows the operating cost of the heater to be 27 cents per day when run at maximum heat, but that on an average the cost is less than 20 cents a day by reason of the full heat not being needed all the time. There are instances where it is claimed that electric heaters are operated more cheaply than stoves could



be, and it is apparent from the excellent results obtained in practice that the cost of operation of electric heaters is not as serious a problem as it has appeared to be, especially as it has been found in actual practice that the fares obtained from the space appropriated by the coal stove fully compensates for the cost of running an electric heater.

As to the sanitary aspect, the least value placed by experts upon the air capacity per person per minute for ventilation is thirty cubic feet. The average 20-foot car contains 900 cubic feet of air, and carries from twenty-five to thirty persons, thus making the proper change of air about once per minute. No street car is thus changed, except by introduction of quantities of cold air when the doors are opened at intervals. If, as in electric heating, a source of heat is placed near the doors, to cause warm air, heated either by radiation or convection, to rise with the cold air, the air is tempered to a considerable extent, and in practice this is found to be an essential feature of the electric heater.

The cleanliness of the heated air of an electric heater is to be also urged in its favor, the air not being heated at the expense of noxious gases.

The items of space occupied, cleanliness, freedom from damage to car, and from carrying in coal and taking out

of ashes, and generally decreased depreciation, are strong factors in favor of the electric heater. We thus see that in practice there is no reason why electric heaters cannot be successfully operated.

The fact that makes it profitable to operate street cars by electricity than by other methods of propulsion, also makes it possible to heat the cars by electricity. Long continued heavy loads, with load lines of moderate maxima and minima, renders the cost of the power to street railroads a comparatively small one, and while the transformations through which the heat energy passes before its expenditure in useful work are many, the prerequisites outside of cost which the electric heater is called upon to fulfill warrants its use.

### THE SPERRY ELECTRIC BRAKE IN CHICAGO.

Probably the most important improvement in braking apparatus that has been made since the introduction of the air brake, is the electric brake, which has recently been perfected by E. A. Sperry, of the Sperry Electric Railway Company, Cleveland. This brake may now be considered as beyond the experimental stage, which is more than can be said in regard to other electric brakes for use on trolley roads, with the exception of the expedient in use at Sioux City, of turning the motor into a generator. The Sperry brake has been in practical service for some time, at Cleveland, Philadelphia and Waterbury, Conn. One has just been put on the Twenty-second street electric line of Chicago, by R. L. Caldwell, who represents the Sperry Company.

The Sperry brake consists, in brief, of a magnetic clutch, operated by current furnished by the motor acting as a generator. To provide for the electric brake, one wheel on each axle is cast with a flat disc, which is polished on its surface and against which the magnet acts.

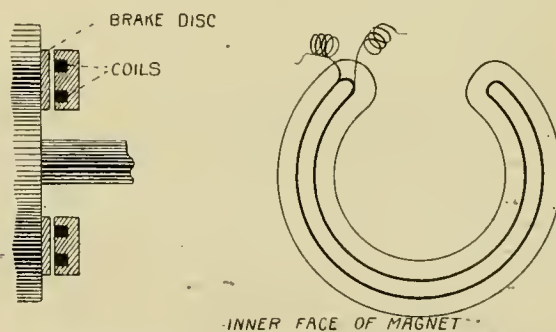

The magnet is C shaped and has an internal coil, as shown in the engraving. It is made C shaped and not a ring so that it can be taken off the axle.

The method of operation is as follows: Both brake and controller are worked by the same handle. Suppose a car to be running with the current on and a stop is to be made. The handle is thrown to the "off" position, and when it strikes the "off" position it throws a switch, which cuts off the trolley current and makes connections, so

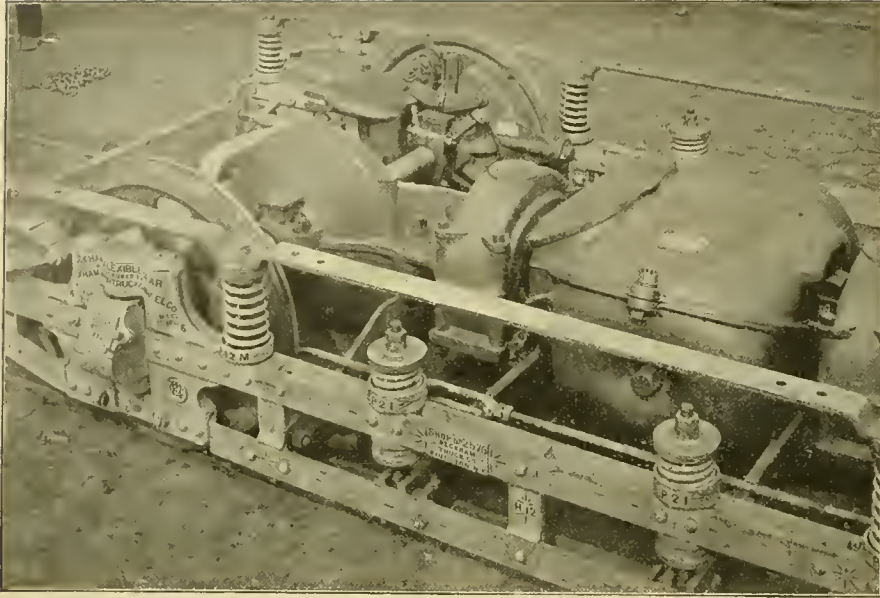

DETAIL OF BRAKE.

that when the handle is put on the first point of the controller, the motor, brake magnets and about eighteen ohms resistance are placed in series with each other. The motor "builds up" immediately, and sends a current through the brake magnets and resistance. The less the resistance in circuit the harder the brake is applied, so that this can be regulated entirely by the controller handle. When the controller is connected as a brake, and is thrown back to the "off" position, it trips a switch, which throws in the trolley current and makes it again an ordinary controller. In other words, every other time the handle is on the "off" position it becomes wired as a brake and every other time as a controller. The simplicity and practical efficiency of this arrangement is too obvious to need comment.

With this brake it is impossible to slip the wheels for more than an instant, as the moment the wheels stop the motor stops generating current. The stops made with this brake are remarkably quick and smooth, as the

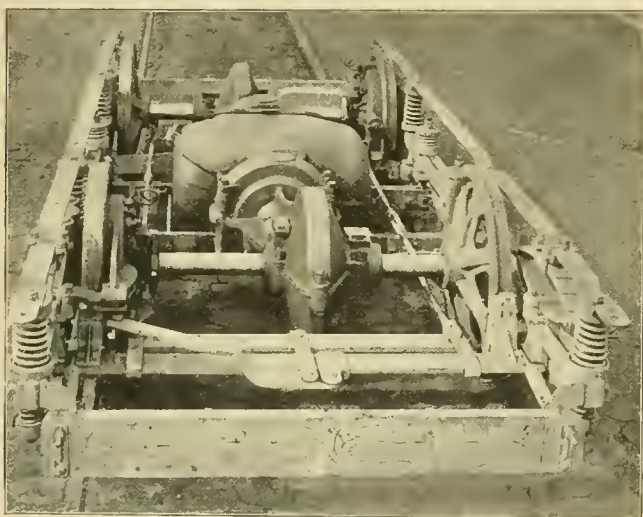

END VIEW OF TRUCK WITH BRAKE.

correct braking principle is applied, of making the hardest application at high speed and automatically reducing it as the speed falls.

The brake is very simple and entirely independent of the trolley current. It introduces very little additional complication in the wiring of a car, as the same rheostat is used in the brake circuit and for starting. The rheostat required is a little higher resistance than the usual one, as it requires about 18 ohms to cut the current down enough to apply the brake easily. As the brake is operated with so small a current there is very little strain on the motor or rheostat. In regard to the wear on the magnet and disc, there is reason to believe that it will be very slight, as a large part of the breaking force is magnetism and not friction and the surfaces have graphite lubrication. The controller box, which is the ordinary size, has an indicator which shows whether the switch is turned to the controller or brake positions. The brake is made for every day use, and is as thoroughly practical a device as the modern railway motor. It can make emergency stops with a minimum of shock, and the service stops are remarkably quick and smooth.

Why go to the sea shore for a vacation trip, when within a night's ride of business the vacationist may find flesh, fish, fowl, boating, and all sorts of healthful recreation among the lovely little resorts reached by the Wisconsin Central Railroad? Even within three hours' ride of Chicago the busy man may find health giving breezes, lakes full of fish and woods full of game. Near Chicago are: Gray's Lake station, with nine ponds accessible; Lake Villa, with an attractive resort; Fox Lake, so well known for beauty, and half a hundred other lovely spots; or if wild scenery is wished, a few hours longer takes the tourist into the most savage of mountains and forests in upper Wisconsin and eastern Minnesota. The Wisconsin Central railroad offices, 204 Clark street, Chicago, will send on application a beautifully illustrated book upon the subject.

The Genett Air Brake Company, of New York, has sold, during the first half of August, air brakes for motor and trail cars to the following roads: Athol, Mass.; Lawrence, Mass.; Lowell, Mass.; Newport, R. I.; New Haven, Conn.; Easton, Pa., and is commissioning brakes on the New Orleans Traction Company's lines, the Lynn & Boston Railway, and the Atlantic Avenue Railroad Company, Boston. The company, under General Manager E. J. Wessels, is pushing its sales into foreign countries also and good reports of its efficiency come from all quarters.

**MAGNIFICENT PLEASURE RESORT OF THE BINGHAMTON, N. Y., RAILROAD COMPANY.**

The 37,000 inhabitants of Binghamton, Broome County, New York, in no wise want for a healthful, beautiful and diverting resort, where holidays and hot evenings may be spent and where the toilers of the week may find rest and pleasure on Sundays. Not only is opportunity of a resort opened, but the Binghamton Railroad Company offers to the prospective pleasure seeker a cheap, rapid and comfortable means of getting to it.

Ross Park, which is the playground for all of Binghamton, and even of the surrounding towns, is situated

of the city of Binghamton, with men and means at its command.

The union and sequence of efforts of the original workers and the later commissioners have made Ross Park a combination of lovely natural effects, chastened and cultured by the hand and mind of man. The hills and dales have been softened by landscape gardening, chasms and gullies have been bridged and filled, and driveways have opened up the innermost recesses to the fancy of the thousands of daily visitors. The natural forest, Pennsylvanian in character, has been properly

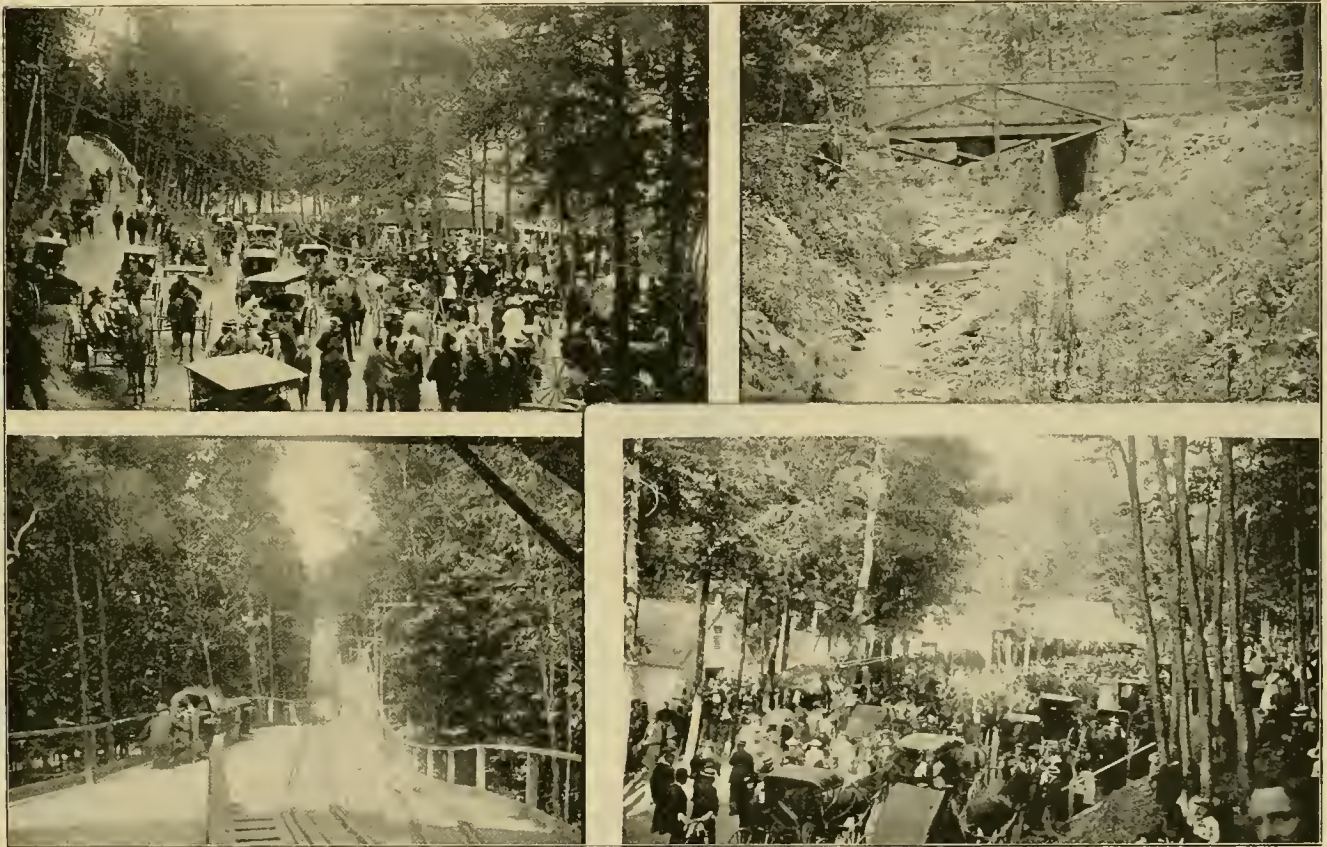

SCENES IN ROSS PARK.

at the extreme south end of the city and covers 100 acres of diversified land. The site was originally presented to the city by Erastus Ross, after whom it was named Ross Park. This was many years ago, before Binghamton became the thriving manufacturing center of Southern New York and before wealth and money had gathered at this bend of the Susquehannah river. The first improvements, therefore, were not the result of special taxation or of large gifts, but the free will offering of personal efforts on the part of the citizens, each public-spirited man adding his own labor to that of his neighbor that posterity might enjoy the beauty and pleasure of which they were deprived. The institution is now governed by a board of park commissioners

thinned where necessity required, and rustic seats and bowers made from the felled timber. Around the crests of hills, roads and paths have been driven and foot passages made an endless labyrinth for the mooning lovers and the more staid fresh air seekers of older growth. The natural wildness of the place has not been vitiated by the designers of the thoroughfares, but rather enhanced. Scattered about at convenient intervals may be found seats, tables and covered platforms, for the use of picnickers and pleasure seekers, while swings and springs are not wanting. The older trees are carefully trimmed and the newer ones planted at proper intervals, so that for endless years to come, that Utopian race which will at some future date inhabit our country may



give thanks to the foresight of the present commissioners of Ross Park.

Besides the numerous foot paths, the beautiful carriage drives through the most interesting part of the park bring out many fine equipages on pleasant days, which add materially to the vivacity of the scene. The carriage entrance to the park is guarded by two heavy brick pillars.

Five years ago the amusement privileges of Ross Park were leased to the Binghamton Railroad Company, and it is now provided with all varieties of outdoor recreations, refreshment stands, merry-go-rounds, and similar innocent pleasures. One of the prominent diversions is a switch-back, represented in our engraving. Besides these material ministrations, the æsthetic nature is served with music "from gay to grave, from lively to severe," on every afternoon and evening of the week, with a more pretentious concert on Sunday afternoons. The best of order is preserved upon the grounds and upon the cars which land the greater number of visitors at the park gates.

The records show that during the season, which begins about May 15, never less than 1,000 people a day fre-

quent the park, and upon a large number of special occasions 20,000 have gathered there. The average attendance is 3,000.

The surrounding towns and villages bring in large numbers of picnics, so that excursions into Binghamton always augment the park attendance.

The present general manager of the Binghamton Railroad Company and the Park Amusement Company is J. P. E. Clark, whose portrait we are glad to present to our readers. Mr. Clark is a young man of boundless energy, great executive ability and business tact. He was born at Troy, N. Y., in 1858, and has been engaged in his present function five years. The other officers of the company are: G. T. Rogers, president, and John B. Rogers, treasurer, both gentlemen of business ability and enterprise, as their

excellent street railway system attests.



J. P. E. CLARK.

#### WASHINGTON PARK, CHICAGO.

While Lincoln Park on the North Side is the most pretentious of Chicago's breathing spaces, Washington Park at Fifty-fifth street on the South Side has many attendants on Sundays, evenings and holidays. The



WASHINGTON PARK, CHICAGO—SEEN FROM CITY RAILWAY CABLE LINE.



landscape gardening of the South park system is all that can be desired, both as regards quantity and quality. The artificial ponds, the trees and most of all the magnificent parterres give the eye and mind the greatest pleasures. Several notable works of art are observable at Washington Park, namely, the flower clock in the form of a sun dial and the gates ajar.

The Sunday, evening and holiday traffic on the various lines of the Chicago City Railway is largely augmented during the summer by these attractions.

THE Calcutta, India, tramways, show a credit balance of \$34,865 for 1893, and a dividend of 2 per cent. was recommended.

### THE SITUATION IN DETROIT.

Readers of the REVIEW have from time to time been informed of the progress, or rather lack of progress, in the street railway controversy in Detroit. We have also shown what an unreasonable and personally prejudiced mayor can do in the prevention of official power. Mayor Pingree has personally prevented Detroit from securing the advantages and enhanced real estate values which the intended construction of additional electric lines would have made possible long months since. We cannot better portray the present situation than to quote an editorial in a recent issue of the Detroit News, which, under the heading "A Severe Blow to Detroit," reads as follows:

"For three years the people of the city of Detroit have been engaged in a calamitous litigation affecting the title to the street railway properties in this city. That litigation has been conducted with the view simple to secure to the people the benefit of lower street railway fares than they had hitherto and do now enjoy. It was started at a time when the city was in the enjoyment of the lowest street railway fares that are afforded in any city in the United States. For two years and a half of this period there was absolutely no bona fide proposal received from responsible capital to undertake the purchase and operation of the properties involved in the controversy. Within the past six months negotiations were begun in good faith, looking to the settlement of the question upon terms that were vastly more favorable than any sober-minded citizen of Detroit had ventured to hope for when the litigation was commenced. These negotiations culminated in a proposal from a competent representative of abundant capital, to give the city the terms it was seeking and to immediately begin the reconstruction of the properties for the introduction of mechanical motive power, provided the new arrangement as to fares should be postponed for the period of thirty months. The acceptance of these proposals was delayed until the federal court, which was considering the equities of the city's case, had heard the argument on the matter and had indicated, apparently, its opinion that the city was in the wrong in its contentions. So far as the decision of that court can be anticipated it is going to be adverse to the city.

Even the prospect of such a decision did not shake the purpose of the gentlemen who were offering these terms. They were still willing to treat. From being a proponent of settlement the mayor suddenly became its adversary. In an official communication to the council he charged fraud to the representatives of the new capital; men whom he had himself invited into the controversy, who met his terms, who agreed to take an ordinance more generous to the city than he had himself put into writing and insisted that the council should pass, and whose negotiations, so far as the public is informed, were almost wholly with him and with his coterie. This declaration has been followed by a new step. The capitalists whom he introduced to the deal have purchased the railway properties and withdrawn all their offers of cheap fares. They are content with the present ordinance. The city must offer hereafter. They will not ask. With the prospective decision of the court they have the upper hand. With many franchises running from five to nine years, they can afford to wait. No one else can get in until the town regains its reason.

This is a sorrowful outcome of what promised to be a most favorable settlement. By dint of denunciation for fraud, Hazen S. Pingree has driven away the negotiators, while they in the meantime have purchased the property and will proceed to bide their time. He has put the employment of the idle labor of this town out of the question for the present year.

The spirit which Hazen S. Pingree, George Beck, Charles H. Buhner, John C. Bleil and Walter H. Coots displayed in this unhappily ended negotiation is not the spirit that has built up this town. It is not the spirit of Joy, of McMillan, of Dwyer, of O'Brien, of Schmidt, of Scotten, or of any of the great builders of whom the town is proud. The town must bide its day to rebuke it, unfortunately all too long, but when it does rebuke, it should make its sentiments plain and incapable of equivocal interpretation."

### HANDLING HALF FARES.

How to take care of half fares so as to prevent knocking down by conductors, is a troublesome question. In fact, the roads that are not troubled with the half fare system may consider themselves very fortunate. Probably the majority of roads make a practice of having the conductors ring up half fares as full fares, making a separate account of the half fares received in their daily report. With this system there is always of course plenty of chance for dishonesty. However, by comparing runs and averaging up, an approximate check can be put on the men. J. F. Lardner, secretary of the Davenport & Rock Island Railway, says that they have very little trouble in keeping returns fairly correct in this way: They sell children's 10-ride tickets for 25 cents. These are punched but not rung up by the conductors. When children's fares are paid in cash they are three cents.

The Omaha Railway sells 15 children's tickets for 50 cents. They are rung up as full fares, but have never

been extensive enough to bother Secretary Goodrich much.

About the best plan that has appeared yet is that used by the Pueblo City Railway, for the particulars of which we are indebted to Superintendent W. A. Martin. Cash half fares are sold in the shape of tickets good for two rides. For the first ride the conductor simply punches the ticket. For the second he takes it up and rings up a fare. A 20-ride commutation ticket is also sold for 50 cents, which is punched by the conductor without ringing up a fare. In this system there is no chance for dishonesty, other than the orthodox kind of failing to ring fares. Each ring on the register calls for a full fare. The round trip ticket is based on the same principle as similar tickets on steam roads.

### A TALL CHIMNEY AT TORONTO.

The Toronto Railway now claims the tallest chimney in Canada. It is 250 feet high and has been building since March of this year. Excavations were made to the depth of 18 feet, at which point solid rock was struck. The concrete foundation, 40 feet square, was built on this. The foundation was tapered up until it stood 24 feet

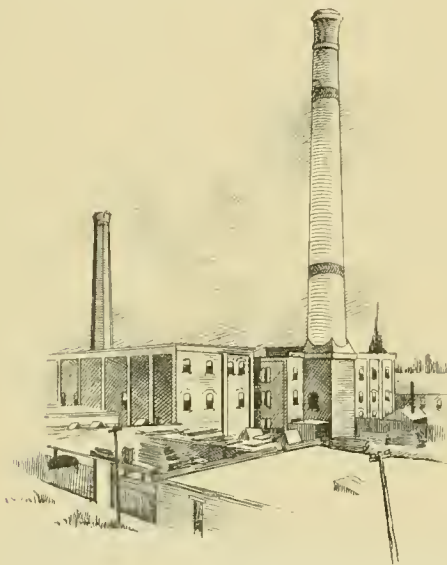

TALLEST CHIMNEY IN CANADA.

square at the surface of the ground and the chimney proper was then begun. The first 50 feet of the chimney is square. The top is capped with cast iron and is 18 feet 3 inches in diameter. The inside diameter of the chimney is 12 feet. Up to a height of 75 feet there is a special cavity lined with fire brick. A ladder made of U shaped irons runs clear to the top. The ends of these irons are anchored in the brick. It is intended that the ascent shall be made inside the ladder. The chimney is designed to carry smoke from 10,000 horse-power of boilers. Its building was superintended by Jas. Hill, of Toronto.

THE first section of the Douglas & Laxey Coast electric tramway was commissioned May 10.

### INDIANA'S NEW LINE.

J. J. Burns, of Chicago, has purchased of Hatch & Chadwick, the street railway of Goshen, Ind., and franchises in Elkhart county, Ind. Mr. Burns has also purchased the Elkhart Street Railway, of Elkhart, and organized the Indiana Electric Railway Company, of which he is president and general manager, and to which he will soon transfer all of the property above mentioned.

It is Mr. Burns' intention to complete the now partly constructed line in Goshen, and to rebuild and re-equip the Elkhart line. The contract for this work has been let to W. W. Hatch, of Kankakee, Ill., who will commence the work as soon as the material can be gotten on the ground. The rails have already been bought and are now being shipped by the Illinois Steel Company.

The track in Goshen, constructed last summer by Hatch & Chadwick, is of the most improved type. Mr. Burns realizes the importance of first-class construction and the use of the latest appliances, and it is his intention to make this system one of the best in the state.

### THAT IDEAL METHOD.

The daily papers of Boston and other cities, with the advantages of rapid surface transit, can not cease from the wail for elevated railways. "They are ideal," say the papers.

New York citizens, however, seem to be of another mind, and as they have had experience with both methods their opinions are worth something at least. The test of transit is the using, and by that test we judge. A recent report from New York says that train after train has been taken off by the Manhattan elevated. The last great reduction was the cessation of seven trains on the Third avenue branch. The size of the trains is also reduced. This makes a total of fourteen trains and denotes a serious loss of traffic. The total loss of passengers is said to have amounted to 52,000 a day, while on the contrary the cable cars are crowded and the patrons seem satisfied that their progress is just as fast and the trains more available. In Brooklyn the same holds good, as an article in a recent REVIEW stated. Verily, Philadelphia and Boston will do well to "let well enough alone" and not sigh for some enterprising citizen to enter into losing competition with popular and sufficient surface rapid transit.

BETTER THE LATTER.—The wealthy uncle was talking over the prospects of his nephew with the lad's mother.

"How is he doing in his studies?"

"Very well. He is very accomplished. He shows great talent for music, and his manner is so haughty, his music teacher thinks he will become a conductor."

"Ah, indeed! Orchestra or tramcar?"

—Tit-Bits.

### THE LARGE WALKER GENERATORS.

Dynamo design is by no means as uncertain an operation as it was a few years ago. The properties which go to make the success of machines of this class are now well known, and the large direct current generators of the Walker Manufacturing Company are designed with an aim to combine all those features. The frames of these machines are cast in only two pieces, except on the larger sizes. The upper half is the yoke with the poles and the lower half the same with the base and bearing

combination of mica and a fibrous material. The armature when running has a strong current of air circulating through it. The slots are such shape that no binding wires are required. The bearings are unusually long and the shaft is also larger than is customary. The field coils are machine wound and waterproof covered. The shunt and series coils are on independent spools. The field cores are laminated iron cast in the yoke. Machines can be over compounded to any amount up to 20 per cent. The bearings are ball and socket, self oiling.

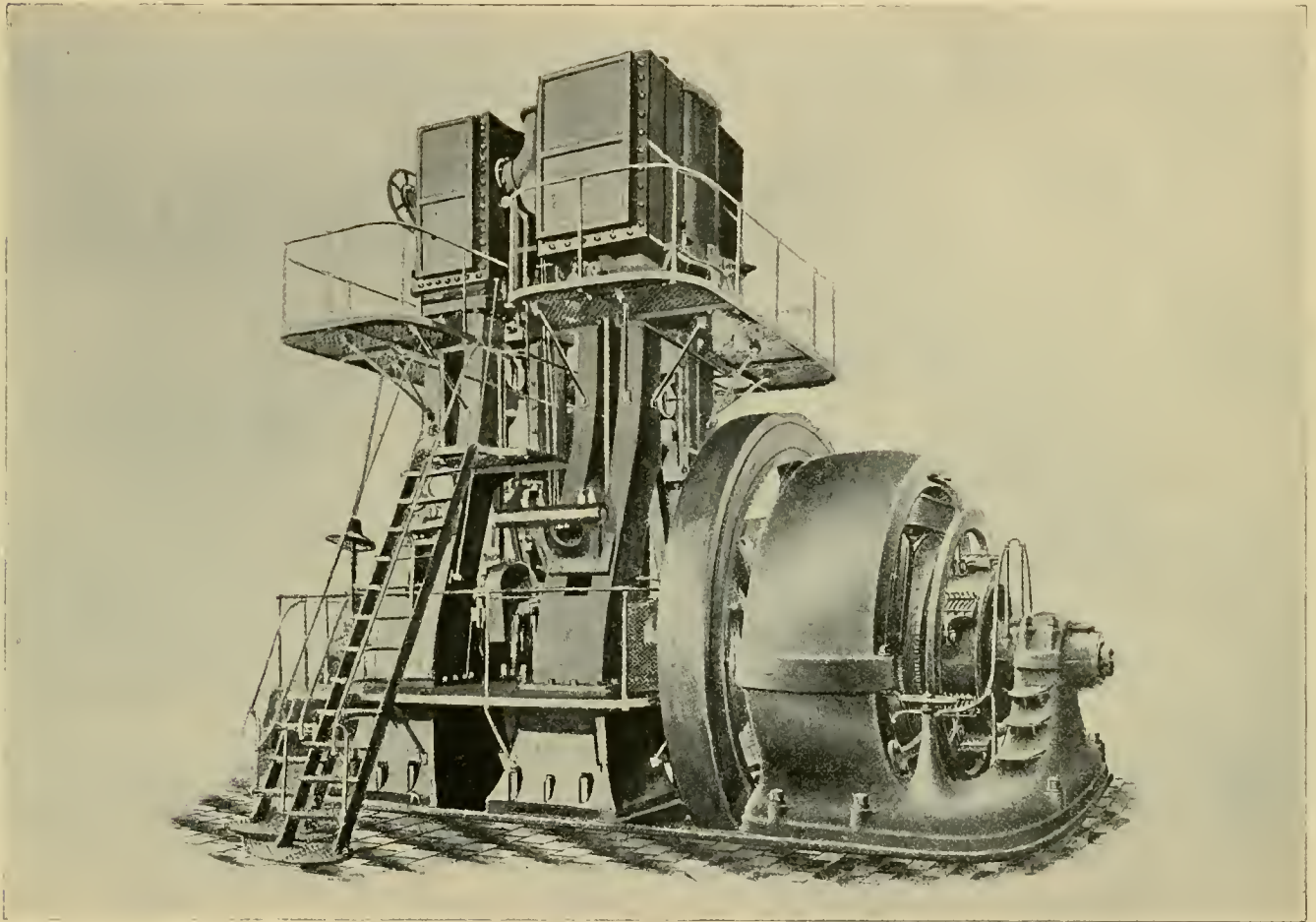

THE WALKER DIRECT-CONNECTED RAILWAY GENERATOR.

standards. The armature is of proportionally large diameter and is of low resistance, with ample cooling surface. It will temporarily stand an overload of 50 per cent without injury or sparking. It is a slotted drum built up from the best quality of annealed iron. The plates are annealed a second time after being punched, and are insulated with a thin coating of enamel. They are compressed into a solid core by a hydraulic pressure of 100 tons. In the smaller machines the windings consist of heavy copper wires, so arranged that none cross within an inch of each other. There are no joints except at the commutator. In the larger machines flat bars are used. The winding is two-path. The insulation is a

W. E. MUIR, formerly of the Point Defiance, Tacoma & Edison Railway, and now general manager of the Hammond, Whiting & East Chicago Electric Railway, reports the road to be doing remarkably well and paying all operating expenses and fixed charges. The line was but recently taken out of the hands of a receiver. A 300-horse-power Corliss engine and generator will soon be added to the station, and the unexpectedly large traffic can then be better taken care of. The completion of the line to the terminus of the South Chicago City Railway was an important step and showed conclusively that the road was destined to become a large and important system.

## THE BARMEN ELECTRIC RACK RAILWAY.

The well known centers of German industry, Barmen and Elberfeld, are surrounded by magnificent natural scenery, forest clad hills and highland. For many years, however, it has been a difficult proceeding to enjoy these natural advantages on account of the lack of proper cheap transportation. Gravity railways and steam rack roads were out of the question, and the inhabitants had about settled back to await the advent of flying machines when the enterprising electrical firm of Siemens & Halske came forward with a proposition for an electrical

The upper terminus is near the Toelle Tower on the summit. This we show in the distance in our engraving. Here, also, it connects with a narrow gauge steam line, which in turn connects with another railroad leading to numerous popular resorts.

The total length of the line is one mile and the total rise is 550 feet. The mean grade is thus ten per cent with ascents as steep as 1 in 5.4 meters and 1 in 7.2. The curves are all of long radius, the sharpest measuring 500 feet. Besides the termini there are two intermediate stops.

The gauge of the track is 39.36 inches and the line is

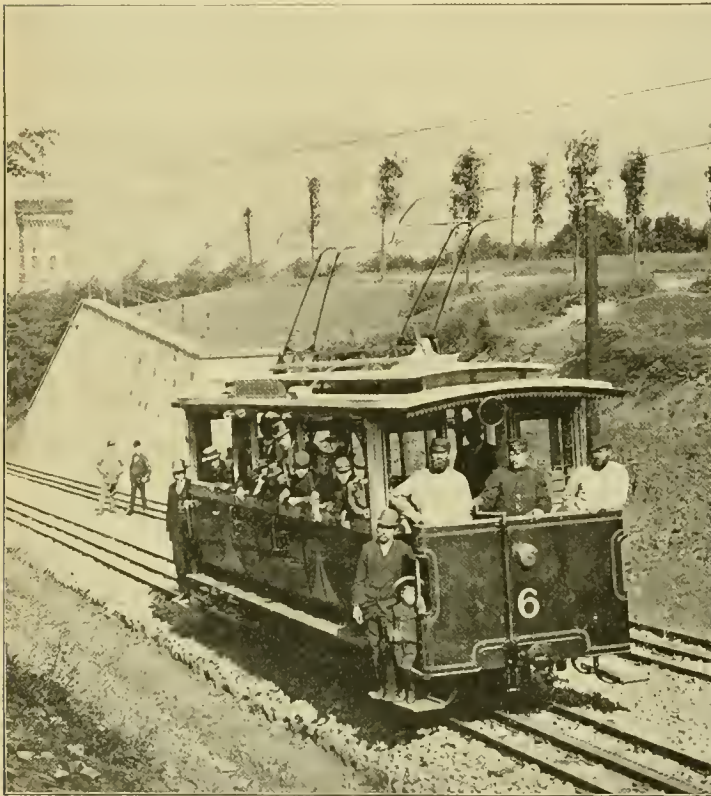

ON THE LINE, SHOWING TRACK AND RACK—BARMEN.

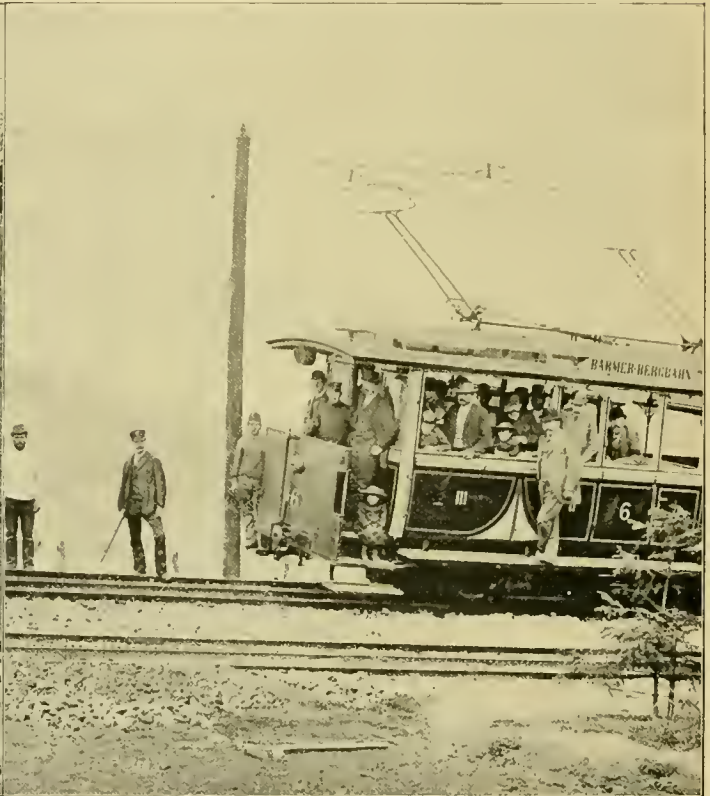

TROLLEY FRAME DEVICE—BARMEN.

rack railway, which was accepted by the Barmen Mountain Railway Company.

The difficulties of the situation will be readily appreciated by a glance at the profile of the proposed line, the grades of which are totally prohibitive of ordinary methods.

The line begins in the center of Barmen, at a terminal station on the Cleferstrasse. Immediately on emerging from a car barn the cars cross the right of way of the Bergisch-Markische State Railway, on an iron bridge of 65-foot span, 30 feet wide. From the bridge the line passes into Kampstrasse on the level. Then it ascends the steep grade of Luisenstrasse, which rises one in five and four-tenths. The line crosses in this route the Gewerbschulstrasse and also the Lichtenplatzerstrasse on the level and then enters the forest at the top of the hill.

double tracked. The rack rail is centered between the track rails. It is of the Riggerbach pattern with  $3\frac{1}{2}$  inch teeth pitched 3 inches apart; each section is 10 feet long. The track rail is flat, except at street intersections. The rails are bedded on iron ties, spaced 40 inches from center to center, and to prevent sliding on the steep grades they are secured to foot plates the entire length, and the ties at intervals of 50 or 60 yards are anchored to concrete foundations.

The cars are 26 feet over all and are divided into four compartments. The inner two being entered from the side, as with ordinary European steam cars, while the outer two are approached by platforms, as in American practice. The two axles of each car are provided with toothed gears that mesh with the rack. Two thirty-six-horse-power motors are attached to each axle. Beside

the ordinary hand brake, an automatic device brakes the car when it exceeds 6 feet per second velocity. The idea is that of a powerful, stretched spring, which is released by a centrifugal governor which throws on the brake at once. A friction safety brake is also in vogue. This

boilers, with a total heating surface of 1,800 square feet each supply steam at 140 pounds pressure. One is held always in reserve. The station is constructed with a capacity of triplicating the plant when it shall become necessary. Two city electric railway lines will be operated from this plant at no very distant future time, besides which the station will supply power for light and factory purposes in Barmen.

At the Barmen terminal is an automatic transfer table operated electrically. The overhead construction is neatly and strongly arranged. The trolley wire is supported by side poles or from buildings, at a height of 16 feet above the ground. Steel tubular poles are used in the down town districts and wooden poles in outlying

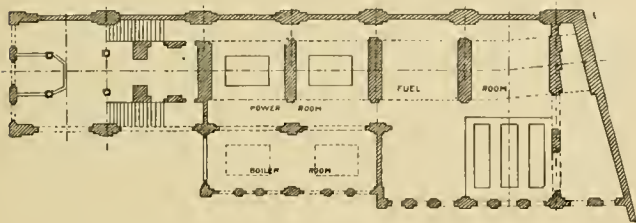

PLAN VIEW POWER HOUSE—BARMEN.

consists of wrought iron shoes operating as a track brake and may be used by hand from either end of the car. The motor, used as a brake, is frequently applied. This is done by using a shunt motor which operates as a dynamo. The Siemens state that on the Barmen

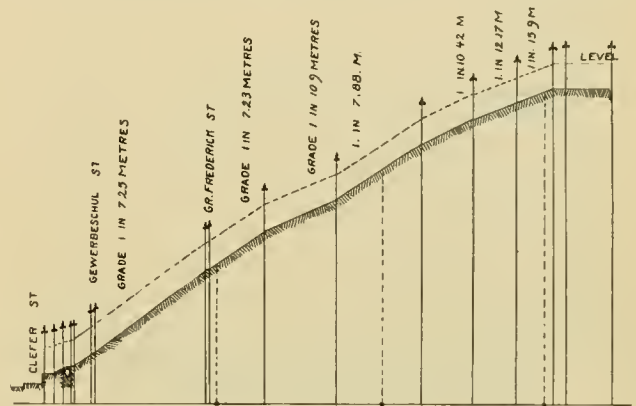

PROFILE OF LINE—BARMEN.



VIEW OF POWER HOUSE AND RAILROAD VIADUCT—BARMEN.

line about one-third of the total energy required for the ascending cars may be relied upon from this current generation in the motors which are descending at the same time. This is equal to 33 per cent.

The generating station is at the Barmen terminus, situ-

places. The trolley contact is of an unique style, as shown in the engraving. It consists of two oblong metal frames, producing a positive sliding contact. These are mounted on the car roof in a similar manner to our trolley poles, and are considered efficient and durable. Besides its merits as an electrical plant of high order, the Barmen Mountain Railway has an unique fame as the only electrical rack railway in the world, and the Siemens & Halske Company has every reason to be pleased with its successful operation.

The engravings we are enabled to present by kindness of the Chicago representative of the Siemens & Halske interests in America.

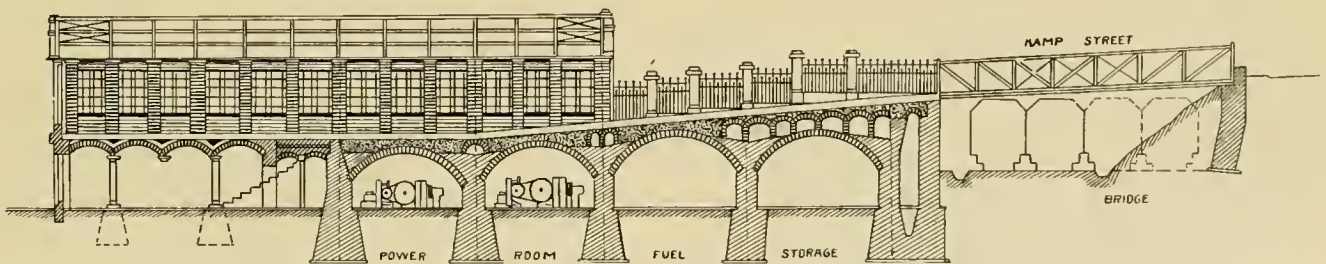

LONGITUDINAL SECTION OF POWER HOUSE—BARMEN.

ated underneath the platforms and rails, see engraving. Here are two compound, condensing steam engines, running at 165 r. p. m., driving Siemens generators direct. The engines are of 250-horse-power. Three water tube

THE Kansas City Railway Company, Kansas City, Mo., has an elegant summer resort called Washington Park. A bathing beach and a dancing pavilion are among the attractions.

## TRANSFERS ON THE CHICAGO CITY RAILWAY.

If all the troubles that transfers give to the street railway manager could be written in a book, the volume would be a big one and the story therein calculated to draw tears from a wooden Indian.

Leon Jewell, the superintendent of time tables for the Chicago City Railway, is the man on that system who wrestles with the transfer and pass problem, and just recently he has put in force a new style of transfer, a few specimens of which we represent.

On the Chicago City Railway there are 75 points of transference of passengers, besides which emergency and car to car exigencies call for special rules.

The transfers and rules are all printed by the company

ods of the transferring conductor and the care to be exercised by him to protect the company's interest from any unscrupulous individual who might wish to do fraud, are such as are suggested universally in similar cases. These are arranged in a small book of 40 pages, convenient for the vest pocket, and no excuse is allowed for ignorance of them on the part of the conductor.

In case of dispute as to lapsed transfers, if there exists any doubt in the mind of the conductor that the issuing conductor might have made an error, he shall take the passenger's name and address, save out the challenged transfer, and report the whole proceeding to the office.

The book also contains the official time tables of the first and last cars and the leaving time of all night cars on the system.

It was a heavy duty to rearrange this great transfer system, and Mr. Jewell is to be congratulated upon the efficiency of the work.

## THE LIGHT THAT FAILED.

As we have so often had occasion to remark, it is the little details of management that go to make a perfect, popular system. Good cars, good track, good motive power and polite employes are necessary, but not a few, having qualified in these respects, fail to carry the good work to out its completeness.

Cars should not only be sufficiently light that the conductor may be able to determine a counterfeit ten dollar bill from a lead nickel, but should enable passengers to read, and read with comfort and without endangering their eyesight. On this point the New York World forcibly comments as follows:

"The Broadway cable cars are so well lighted at night that passengers can read their newspapers with ease and comfort.

The cars of the elevated railroad company are so dimly lighted that most people cannot read at all in them, while those who do must secure particular seats and subject their specially good eyes to a dangerous strain.

That it also diverts thousands of passengers from the elevated to the surface lines is certain. If the managers doubt this they will find the fact unmistakably recorded in their own traffic reports and those of the better surface lines. Their own reports show a considerable loss of traffic during the last three months, while those of the Broadway road exhibit a marked gain. There can be no doubt that between Forty-second street and the City Hall the great majority of passengers to whom a choice between these two lines is open choose the cable cars.

Thus the lack of proper illumination is costing the elevated people really more than the proper lighting would. If the company were under control of an alert and judicious business man this consideration alone would be conclusive. But the elevated roads are under control of two men, one of whom is too old, the other too young, and both too stingy to look favorably upon improvements that cost money.

21	11	01	06	8	2	9	5	4	3	2	1	Wd	61st or 63rd at Cottage Grove.			
1	2	3	4	5	6	Chicago City Railway Co. TRANSFER SLIP FROM		Valid unless used on		JUNE 1 1894 as indicated hereon.			B. Chicago Ave. or 55th at Cottage Grove.			
COTTAGE GROVE LINE.																
Receivable only at transfer point as indicated by punch for a continuous passage within 60 minutes from hour punched. Void if mutilated, or if punched in more than one place for hour or street.																
A.M. FOLLOWING DATE: <i>ShWhuler</i> Pres't.																
A.M.		6		7		8		9		10		11		12		SOUTH on Cottage Grove at 55th.
5		6		7		8		9		10		11		12		47th at Cottage Grove.
Van Buren or 22nd at Wabash.				26th at C. Grove.				31st at C. Grove.				35th at C. Grove.				SOUTH on C. Grove at 39th.
																SOUTH on Cottage Grove.
																39th or 43rd at Cottage Grove.

21	11	01	06	8	2	9	5	4	3	2	1	Wd	Valid unless used on		
1	2	3	4	5	6	Chicago City Railway Co., TRANSFER SLIP.		Valid unless used on		AUG 25 1894 as indicated hereon.					
Receivable only SOUTH on HALSTED at O'NEIL or EAST or WEST on ARCHEL at HALSTED for a continuous passage within 60 minutes from hour punched. Void if mutilated, or if punched in more than one place for hour.															
A.M. FOLLOWING DATE: <i>ShWhuler</i> Pres't.															
A.M.		6		7		8		9		10		11		12	
5		6		7		8		9		10		11		12	

21	11	01	06	8	2	9	5	4	3	2	1	Wd	Valid unless used on			
1	2	3	4	5	6	Chicago City Railway Co. TRANSFER SLIP FROM		Valid unless used on		JUNE 1 1894 as indicated hereon.						
CLARK AND VAN BUREN.																
Receivable only at transfer point as indicated by punch for a continuous passage within 60 minutes from hour punched. Void if mutilated, or if punched in more than one place for hour or street.																
A.M. FOLLOWING DATE: <i>ShWhuler</i> Pres't.																
A.M.		6		7		8		9		10		11		12		NORTH or SOUTH on Wabash at Van Buren.
5		6		7		8		9		10		11		12		WEST on Archer at Phoeby Transfer.
																SOUTH on Clark at Van Buren; or SOUTH on Wentworth at Archer.
																To be issued going SOUTH only.
To 26th at Halsted; or To 22nd, Halsted or Ashland at Archer; As Above Only. B. or WEST on Archer at Pittney. C. Cash.																

on its own press and at its own printing office, an institution that has been of very great service in the economy of the plant and management. This printing office was first established by the editor of the REVIEW, then secretary of the company. Here, also, are printed general orders, maps, and other reading matter used by the company.

On one transfer slip the word "cash" will be noticed. This denotes the fact that a second transfer MAY be issued from it, same as a cash fare.

The great number of transfer points necessitates special rules for the guidance of conductors as to time and place of transfer. These, of course, are governed by local conditions and are not therefore of general interest enough to recapitulate. The general rules governing the meth-

LEAVENWORTH'S LINE.

The Paying Electric Railway of Historic Leavenworth—Salt Sea Baths of an Inland Town—The Men Who Made the Line.

On the afternoon of July 18, a distinguished party of the honored citizens of Leavenworth, Kas., gathered at Tanner's park, in that city, to participate in the ceremony of driving the golden spike that denoted the completion of the Leavenworth Electric Railway. They also incidentally paid their respects to the promoters and builders of the line, the brothers, Newman and Louis M. Erb, who, in the face of opposition, discouragement and difficulty, have succeeded in putting into operation one of the most complete of western electric railway systems.

Sixty-seven years ago, when Col. Leavenworth selected the site for the outposts of civilization, he showed both his appreciation of natural advantages as well as a deep consideration for posterity, by settling his troops on the Missouri river, in a high and healthful land, of commanding position. Besides its strategic value and the fertility of the soil, the place was directly in the line of all the plains traffic.

Since that time some 22,000 other people have considered Leavenworth as the only place worth living in, and its population has enjoyed, as time has progressed, all the latest and best things, æsthetic and physical, except one, and that the Erb brothers have supplied to a queen's taste.

Eleven years ago, Tom Stivers secured a franchise for a horse line, and, enterprising man that he was, bonded the two strips of rails and a few bobtail cars for four times their most extravagant valuation. The result was ruin and gnashing of teeth to the bondholders, annoyance to the citizens and detriment to the town. Six years



THE ELECTRIC FOUNTAIN.

secretary and treasurer, J. P. Edrington; general manager, Louis M. Erb. The line includes thirteen miles of track of standard gauge, with maximum grades of three per cent. The rail, with the exception of one mile of Johnson girder, is 60-pound Illinois Steel Company's T. The road-bed is substantial and well constructed.

The rolling stock consists of eighteen handsome cars, made by Stephenson, of New York, and the American Car Company, of St. Louis. All cars have 5-foot platforms, 20-foot bodies and are thirty feet over all. Our engraving shows a representative car, and it goes without saying, that the two companies named as builders never put out anything but first-class vehicles. The trucks were made by the Peckham Motor Truck and Wheel Company, which fact insures all Leavenworthians an easy, joltless ride. Two 25-horse-power General Electric motors are under each car.

The power station is 50x150 feet in dimensions and contains two engines, one a 200 horse-power, made by the Ball Engine Company, of Erie, Pa., and one 400,

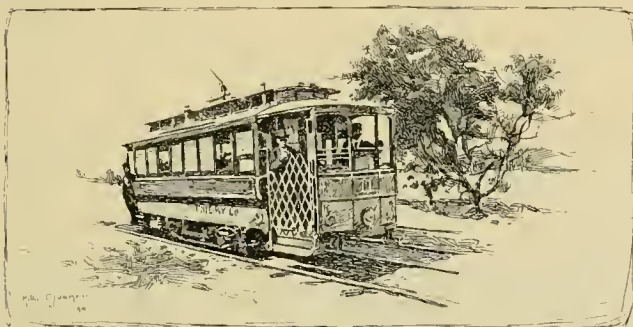

VESTIBULED CAR.

ago a dummy line was built to the fort, which is very close to the town, but the service was neither pleasant nor profitable. Then an affable young man came forward with a compressed air scheme, which finally collapsed for lack of wind, and the dummy line and horse line went into the receiver's hands—Newman Erb.

Mr. Erb, after considerable difficulty, obtained a fair and honorable franchise, and the result is told in the story of the golden spike and the plaudits of the citizens.

The company was reorganized July 1, 1894, with the following officers: President, Newman Erb, New York;

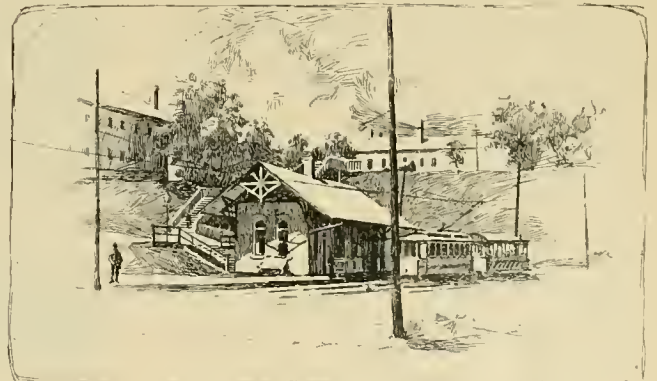

STREET CAR DEPOT.



KEELEY GRADUATES PARADE.

built at Sioux City. Both do excellent service. Six boilers, aggregating 750 horse-power, furnish steam. They bear the name plate of S. Freeman & Sons, Racine, Wis. Berryman's feed water heaters are in vogue and four General Electric dynamos, aggregating 425 horse-power, complete the list of the standard equipment of this excellent station.

#### THE TRAFFIC.

Leavenworth city, as has been stated, has a population of 22,000, and a progressive and liberal population it is. Besides this, directly north of the city and connected with it by the electric service, is the military reservation, which contains nearly 7,000 acres of beautifully improved land and a contingent of two thousand or more United States regular soldiers. The buildings on the reservation are all substantial stone structures. The fort, as it is popularly called, is also an important military school and hospital. There are a number of important buildings on the reservation, and a magnificent statue of the late General Grant. The fort also contains an additional 1,000 men, who do not ride on the street cars, for why, they are incarcerated in the military prison. These are employed in making shoes, brooms, etc., and in working upon the grounds. Leavenworth owes much prestige to the fort, as well as considerable commercial benefit.

On the south of the city, also connected with the railway system, is the western branch of the National Soldiers' Home. An average of 2,500 veterans of the civil war are here maintained. The old soldiers work or play, as they choose, and have much greater latitude than the contingent at the fort, so that the street railway profits considerably by their excursions down town. One of the interesting incidents of the home's life is the parade of the Keeley cure brigade. These are headed by Col. Smith, the governor of the home, who is also a Keeleyite. The

grounds and surroundings of the veterans' last home are exceedingly beautiful, while the buildings are tasteful and commodious. Lake Jeannette, on the grounds, is a beautiful little sheet of water, and General Manager Erb has added to the grounds a modern electric fountain, a sketch of which we show. It is the only specimen of this kind of work in that section of the country, and besides ministering to the veterans' pleasure, is the object of many pilgrimages of the townspeople to the home. Thus the resorts afforded by national enterprise are the fort and the home. The fort's dress parade, every evening, with band concerts in fine weather, is a very profitable affair for the street railway company, as well as a constant delight to the citizens, while after night the electric fountain is always sure of a large number of visitors. The cost of the fountain to the railway company was \$15,000, and Mr. Erb's generosity is greatly appreciated by the people in general and the inmates of the home in particular.

As a commercial point the

#### CITY OF LEAVENWORTH

has considerable importance on account of the cheap coal found in the vicinity. This makes it naturally a desirable manufacturing point. The main establishments are stove works, bridge works, wagon and buggy factories, linseed oil mills, flour mills, machine works and brick yards. In relation to the latter it may be said that their quality is excellent for all purposes and the city paving is mainly done in brick. The town is surrounded by hills of fine limestone, which makes a strong impression upon the architecture of the city and gives opportunity for local architects to express their ideas with greater fullness than is possible to their brethren of less favored places.

The coal wealth of the city employs 1,100 men in five different mines, and no doubt further developments will greatly increase the importance of the Leavenworth coal fields.

It is to one of the coal mine shafts that the street rail-



U. S. TROOPS ON PARADE.





INTERIOR OF NATATORIUM.

way is accidentally indebted for an absolutely unique method of inducing travel.

It had been noticed ever since the beginning of mining operations in Leavenworth that the coal diggers and others employed in the mines had immunity from rheumatism. An investigation of the matter by physicians and chemists showed that the cause was undoubtedly the presence of salt water in the mines, mixed, as is natural under these circumstances, with other mineral substances of therapeutic virtue. In one shaft the flow of salt water was so great as to require a large pump to keep the mine in condition to be operated.

The idea of utilizing this wealth of mineral water as a bath was often thought of, but its distance from the city made it impossible for the great majority of the citizens to derive benefit from the healing flow.

When the electric railway became assured, however, the Leavenworth Coal Company took immediate steps to improve the facilities for bathing, and erected a bathing pavilion of the form shown in our engraving. The cars come within a thousand feet of the building, and a broad walk leads to the natatorium door. The interior of the natatorium is shown in our engraving. The pool is 25x

retiring rooms and shower baths are provided for the comfort of patrons. The shower bath is as essential as at Salt Lake, since the Leavenworth bath contains only five per cent less salt than that water, and sulphur and other minerals in solution added to the salt. Four large arc lamps light the pool and a springboard is provided for the use of the lovers of aquatic ground and lofty tumbling. Hanging rings and a traveling crane arrangement are at the disposal of the timid bathers who wish to learn to swim. The traveling crane runs north and south the length of the tank and has suspended from it a leather loop for the support of the learner. Competent attendants and special watchmen guard the safety and morale of the place. The pumps which raise the water from the mine shaft to the pool have a flow of 28,000 gallons a day.

The curative powers of the water act upon rheumatic and dermatic diseases, as well as upon lesser affections of humanity in general.

As many as four hundred persons a day patronize the natatorium, and the success of the enterprise has already prompted the promoters to double the capacity of the tank, to accommodate the increased number of visitors. The



NATATORIUM—EXTERIOR VIEW.

cost of the present plant is \$5,000, upon which sum a handsome profit has been realized by the nominal charges for the privilege of the place. The street railway company owns no stock in the natatorium, but reaps sufficient profit from the traffic thereto induced.

THE ERB BROTHERS.

The account of the success of the Leavenworth Electric Railway would not be complete without particular mention of the two gentlemen through whose financial strength and business foresight it has been made possible.

President Newman Erb is a prominent New York capitalist, interested in a number of other successful western enterprises. He is a fine judge of properties and a sound man in every respect.

General Manager Louis M. Erb, to whom the town of Leavenworth is directly indebted for its fine electric railway system, is a man of ripe railroad experience, having passed eleven years as general claim agent and tax commissioner for the Kansas City, Wyandotte & Northwestern, and in the claim department of the Southern Pacific Railroad.

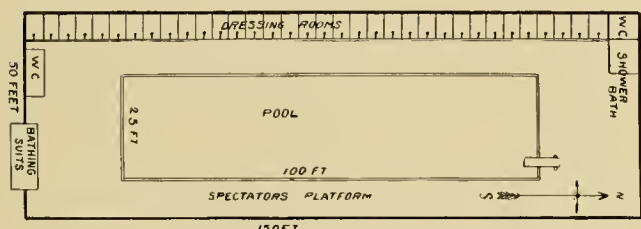

PLAN OF NATATORIUM.

100 feet in dimensions and slopes down to a depth of seven feet six inches. At the south end, near the entrance, is a bathing suit booth, where these useful and necessary garments may be obtained for a trifling sum. On the west side of the pool are ranged thirty-four dressing rooms, each lighted by an incandescent lamp. Opposite the dressing rooms, on the east side of the pool, is a spectator's gallery and railing. The necessary closets and

Mr. Erb is a native Kansan, having been born at Eudora, forty miles from Kansas City. He is apparently about thirty-five years of age, of a thoroughly business make up, affable, courteous and obliging. He is a tremendously energetic worker and capable of carrying any affair through seemingly insurmountable difficulties. Mr. Erb built the thirteen and one-half miles of his electric railway



NEWMAN ERB,  
President.



LOUIS M. ERB,  
General Manager.

in three months and made it one of the most substantial roadbeds in the west. En route he passed through three and one-half miles of concrete paving. Mr. Erb has every confidence in the future of Leavenworth and the city is to be congratulated on having for the manager of its rapid transit system so progressive and thoroughly alive man as Mr. Erb.

### THE DEADLY LIGHTNING.

A government publication places the deaths by lightning in the United States for 1893 at 209 and in 1892 at 251. In the eight years to 1893, 3,516 fires were caused by lightning. In Massachusetts the following tabulation shows the year, number killed by lightning, and the fires from the same cause:

Year.	No. Killed.	Fires Caused.	Year.	No. Killed.	Fires Caused.	Year.	No. Killed.	Fires Caused.
1892	10	65	1891	—	31	1890	6	45
1889	4	25	1888	3	42	1887	1	47
1886	7	28	1885	4	37	1884	3	29

It will thus be seen that although the number of deaths and fires by lightning has not decreased, there seems to be no regular increment of the danger. In 1884 there were three deaths and 29 fires, in 1887 one death and 47 fires, while in 1891 there were no deaths, but 31 fires. We do not argue that these figures prove absolutely the fact, but they tend to disprove the assertion that the increased mileage of electric street railways' wires and tracks is responsible for the lightning that from time to time kills cows and ignites haystacks many miles from an electric railway track.

The year 1893 was singularly free from destruction of life and property by fire, although the official reports have not yet been published. It seems therefore that the ancient superstition relative to the conductivity of rails and wires as a path for thunderstorms must pass it into the limbo of exploded popular opinions, where may be found the deadly trolley fabrication and the car starter idea.

### STREET RAILWAY SPRINKLING AGAIN.

Each season sees an increase in the number of companies which follow the excellent practice of running a sprinkling car. It not only helps the power station, but helps the pocket book, if the property holders along the route do their share toward paying for the comfort of having a dustless street. The Toronto Railway Company is in the business this season with three sprinklers built in the company's barns. They have tanks holding from 2,800 to 3,000 gallons of water, and when filled will sprinkle about ten miles of single track without refilling. At first the sprinkler was arranged to sprinkle both tracks at once, but it was found that in the down town sections where the headway of the cars is in some instances 15 seconds or less, it was necessary to shut off when passing motors on the opposite track, which left dry spots every few feet. Now only one track is sprinkled at a time, and it does the work better and is not much more expensive, for although the mileage is doubled, the increased speed which can be made when sprinkling one track almost makes up the difference. The city gives the water free, and has made arrangements for filling by placing large hydrants at the ends of the street railway

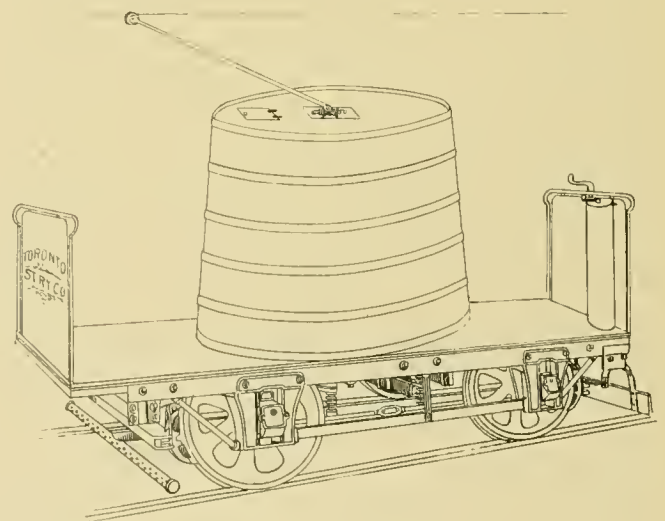

THE TORONTO SPRINKLER.

lines. The tank can be filled from these in about five minutes. The sprinklers do not impede ordinary traffic much, as they start in ahead of the regular passenger cars at the ends of the lines.

There are over 80 miles of track to sprinkle at present, and 65 cents a mile per day is received from the property owners along the lines for the service of four sprinklings a day. The width of street sprinkled is 16½ feet. The one sprinkler which was in use before the two others were finished ran from 150 to 160 miles per day and made a gross income of \$25 per day.

At Champaign, Ill., a sprinkler is also in use by the street railway, and it has proved to be very popular with the public.

The Chicago City Railway has for a number of years made a practice of sprinkling parts of its cable lines with

tanks hitched on behind trailers on the regular cable trains. They sprinkle only about 6 inches outside of the rails of a single track. One man constitutes the crew, his principal duty being to shut off the water when the train stops for passengers.

---

### TRANSPORTING FIRE APPARATUS ON ELECTRIC RAILWAYS.

---

In our July issue, reference was made to the plan of George B. Grant, of Lynn, Mass., for carrying fire brigades and apparatus on electric lines. While at first the plan would seem very limited in application, it appears very much more important when it is understood under what local conditions it is proposed to inaugurate the scheme.

That part of Massachusetts surrounding Boston is very thickly populated and the numerous small towns are all connected by the electric railway, making communication very easy. Very often a fire will get beyond the control of the department of one of these municipalities and aid is asked from adjoining towns. For example, Lynn is about ten miles from Boston, and whenever a company is called from Lynn to aid some brigade in the outlying districts of Boston, four or more horses are sent with an engine and a like number with the hose carriage. The men, with the exception of the driver, are sent on a train. Sometimes they can catch a train that enables them to reach their apparatus at a favorable time, but very often they do not. Salem, Mass., has a car on the steam road ready at all times for out-of-town calls. It has usually so happened that whenever they are asked for assistance they have arrived at the city calling for help in good season, but have been unable to unload because they were side-tracked in some inconvenient place and had not their horses with them.

It is now plain with what advantage the electric road can be used in this service. With such a network of electric road as exists around Boston and will exist soon around all other large cities, it is possible to land fire apparatus within a very short distance from any large fire. Assistance is not asked until a fire has covered a territory near which there must be several electric lines. Wherever there is enough property to make a serious fire electric roads will be found. Mr. Grant's plan is to have a double truck car with a 3-inch plank floor laid on 8x8 stringers. The sides would be closed and the ends built so that when let down they would act as skids or inclined planes. When the car was wanted the horses could pull the engine on the car and the ends would be closed. At the destination the other end would be let down and the horses would be able to start immediately with the engine. The engine and horses would weigh about six tons. The car would need to be twenty-seven feet long, not including platforms at the ends. The car could be electrically equipped, but Mr. Grant's intention was to have this car towed by a motor car, in which the fire company would ride. This would keep the men

with the apparatus. A spur track could be run from the engine house to the street railroad and the car stored there.

The committee of the Lynn fire department, which considered the matter, decided against the idea on account of cost, liability to frighten horses and improbability of being able to make much faster time than with horses. The first reason will hardly hold water, in view of the simplicity of the car proposed. It certainly would not frighten horses more than an ordinary electric car or a fire engine on the street. As to speed there is no doubt but that better time could be made between villages with the car, unless some new breed of horses has been discovered that can haul an engine along a country road at twenty or thirty miles an hour. If a blockade occurs in crowded districts it is but the work of a moment to unload the engine and take it the rest of the way with the horses. Although Mr. Grant's scheme was not favorably received at its first proposal, it will probably ultimately be adopted in the end, as are all other good ideas.

---

### FAMILY OUTINGS.

---

The Citizens' Street Railway Company, of Muncie, Ind., advertises an unique method of inducing travel in connection with a resort. The daily papers bear the following notice: "The Citizens' Street Railway will give a family outing, Wednesday, July 11, at West Side Park. One fare, 5 cents, will take you from your homes and return; tickets good from 7 a. m. to 10 p. m. Children under two years of age carried free. The park is fitted with swings, row boats, seats and other improvements."

---

### A MEAN ADVANTAGE.

---

A young man and a young woman changed from a Belt Line to a Fourteenth street car at the avenue, Washington, and sat in one of the seats in the first car. He was carrying an overcoat and a satchel and was evidently going away. She wore a shirt waist and dark skirt, as if starting out on a shopping expedition. Just before they reached Sixth street he leaned over her and said quietly, so quietly that only the Post reporter back of them could hear: "I am going to kiss you good-by when I leave the car."

"Oh, please don't," she said appealingly; "not before all these people."

But he was decided and said persistently: "Yes, I shall; so raise your veil. If you try to resist people will see it and wonder about you, and they will look at you all the way up town after I get off."

She glanced up shyly and then slowly raised her veil. He bent over her and kissed her and no one in the car looked up. A few people wondered why she was so anxious to show the diamond ring on her left hand, but nobody but the reporter appreciated the fact that she was trying to justify the kissing by means of an engagement ring.

## STREET RAILROADING IN THE

## EARLY DAYS

There is one serious objection to history, from a newspaper standpoint. Nobody can make history out of the whole cloth and have humanity hold any great respect for his understanding for any length of time. History is unfortunately a matter of growth, and it can not be hastened by artificial methods. Hence, heretofore, history as applied to street railways, would have been only a description of contemporaneous events, not history in the proper acceptance of the term. Street railways have not, until within the last few years, been capable of producing a history of themselves. Events, however, of the past six years, and notably of the last four annual cycles, have made it possible to relate stories of "ye olden tyme," of those blissful, happy, even days of horse cars, when street railway men were known as "hoss-car drivers," and "passengers per oat-power" was a jibe of the daily press.

*Tempora mutantur et nos mutamur in illis.*

Street railroad men are now known as rapid transit magnates, commanders of the destinies of cities and the inhabitants thereof, street railway bonds are quoted in Wall street, and the real estate individual seeks upon his bended knees the favor of a word as to where "that new line is to run." Poetic retribution has come upon the daily press, and the playful remarks as to oats and hay have become an unearthly howl against the "octopus," accompanied by an itching palm for one-dollar-a-line locals and passes to "our young men."

So geht es weiter.

History of street railways has thus become a fact. Electricity and cable traction has wrought the change, and the last few years has seen the emancipation of "that noble animal, the horse," and the harnessing of the occult power of Steam, and its child Electricity, to the uses of mankind.

It will not therefore be uninteresting to trace in a few cities the rise of rapid transit, and place in a monument of type the glory of the early struggle of what the most eminent political economists declare to be the salvation of the centers of civilization, the cities, and the savior is rapid transit.

It is the purpose, therefore, of the REVIEW, from time to time to spread upon its pages the story of the fight for rapid transit against the ignorance of hoi polloi and the venality of the patres urbis.

The first that comes to our hand is the story of how

ROCHESTER, N. Y.,

fought its way from horse to electricity.

The beginning in Rochester was the organization of the Rochester City & Brighton Railroad Company, which was legally launched in June, 1862, to construct,

operate and maintain a street railroad in the city of Rochester, and with tracks out to Brighton, a small village, about two miles east of the city. It was, however, over twenty-five years later before the road was built to Brighton, and then by a different route than that originally intended. This was the result of an injunction obtained by Mr. John Craig, a property owner on the avenue leading out in that direction. The case of John Craig vs. The Rochester City & Brighton Railroad Company stands to-day as the law in certain cases where the line of the street is not mentioned as the boundary of the lot. At that time there was no law except the General Railroad act, under which a street railroad could be built. It was not until 1884 that the first street railway act was passed. The first officers of the company were Wm. Kidd, president; H. S. Allis, treasurer, and William F. Holmes, secretary. The stockholders were mainly residents of Rochester, but about one third of the capital invested was from New York City and vicinity. The original directors were: Wm. Kidd, H. S. Allis, Lewis Seyle, P. Berry, L. Ward Clarke, H. A. Palmer and Daniel Warner, of Rochester; Nelson Randall, of Homer, N. Y.; Edward R. Phelps, of New York City; Albert H. Hagar, of Brooklyn; John Butler, Jr., of Tarrytown, N. Y.; Thos. T. Davis, of Syracuse, and Thomas J. Barr of New York City.

Much difficulty was experienced in getting started and in the construction of the road, as at that time street cars were a new institution, and but few of the larger of the eastern cities had any street railways in operation.

After various trials and tribulations, and by dint of laying track on legal holidays and Sundays, to avoid injunction, nine miles of single track were laid by 1865.

The original capital stock of the road was \$200,000, with an issue of \$50,000 in bonds. The first mileage was laid by Tenbrook, Booth & Co., contractors, who took part of their pay in stocks and bonds. The receipts in 1865 amounted to \$53,000, with operating expenses at \$65,000. Its early history was similar to that in many other cities of that time, and in 1868, having defaulted on its interest and having so far proved a losing investment, the road was sold by the sheriff to C. B. Woodworth, for \$45,000. A new company was formed, and the road was reorganized completely and put upon a paying basis.

From 1865 to 1889 (when the road was sold to a syndicate of capitalists from Pittsburg, Philadelphia and New York), it was under the ownership and management of the same officers, with the exception of one or two years in the commencement, viz., Patrick Barry, president; C. B. Woodworth, treasurer; C. C. Woodworth secretary, and Thomas J. Brower, superintendent.

The system was operated by horses until 1890, when electric power was introduced, a proposition which had been under the consideration of the former owners.

During the earlier period, from 1862 to 1868, the operation of a street railroad was not the systematic matter of the present day, the result of long years of experience. With single tracks and turnouts, it was impossible to run very closely to schedule time, and the frequent delays destroyed the efficiency of the service. The era of improvement having begun, the matter of following it up with the increase and betterment was part of the spirit of electrical progress until, today, in the confines of the corporate name of the Rochester Railway Company, there are seventy-five miles of electric track, three hundred cars and a capitalization of \$5,000,000.

The secretary of the reorganized company, and a man foremost in the early development of electric traction, to whom we are indebted for the above facts, was

CHAUNCEY C. WOODWORTH,

whose ability has been rewarded with comfortable retirement and enjoyment of the fruits of his foresight and diligence.

Mr. Woodworth was born at Rochester in 1843, and has always been a loyal citizen of that city. He was graduated at old Williams in 1864 and entered business with his father immediately thereafter, until the connection alluded to previously with the Rochester City & Brighton Railroad Company.

As secretary of the corporation he remained twenty years in street railway work.

"I was one of the small number of street railway men," says Mr. Woodworth, "which went down to Boston some ten or twelve years ago and organized the American Street Railway Association. (It was thirteen years ago. The first meeting was held at Boston December 12, 1882.—ED.)

"The prime movers in forming the Association were: Messrs. Lettell, then of Louisville; Watson, of Buffalo; Cleminshaw, of Troy; George B. Kerper, of Cincinnati; Walsh, of St. Louis; Clegg, of Dayton, Ohio; Tom Johnson, then of Indianapolis, who brought along with him a piece of the since famous girder rail, which was shown, and looked at by the others with no little curiosity. Longstreet, of Providence, and Holmes, of Pittsburgh, were also a part of the "Old Guard." Walter Jones, of Troy, was one of the active members of the party, all of whom were somewhat anxious to see with what welcome the party, which had a private

car, would be welcomed in Boston by the street railway men there.

"The meeting was called at the appointed time, and the Boston men were a little wary at first, standing around the door to see what kind of men would assemble at this convention. They soon came in, however, and took an active part in the proceedings, and the matter assumed shape as the different eastern cities were represented. It was one of the most interesting meetings the association ever held. Calvin Richards, of the then Metropolitan Railway Company, and Mr. Rugg, of the Highland Railway Company and others, of Boston, joined in the spirit of the occasion, so that at the end the Boston street railways gave the delegates an elegant banquet at Young's Hotel. The Hon. Moody Merrill was the chairman of the convention, and Messrs. Woodworth, of Rochester, and Clegg, of Dayton, O., were the secretaries of the meeting. Two days were spent in organizing and adopting a constitution and by-laws."

After the sale of his interests in the Rochester Railway to the present syndicate, Mr. Woodworth joined Henry A. Everett, of Cleveland, in the purchase of the Toronto, Ontario, railway, which interest was two years later sold to Mr. Everett. Since then Mr. Woodworth retired from active business, but not from active interest in American street railways and the American Street Railway Association.

Mr. Woodworth's many friends will be pleased to see the excellent likeness of him which we present upon this page.



CHAUNCEY C. WOODWORTH.

THE Consolidated Street Railway of Cincinnati, O., is building a large addition to the Walnut Hills power house, to furnish the power to the Norwood line and the cross town line, now receiving their electricity from the Hunt street plant. The new building is 50 by 70 feet, one story of about thirty feet. The plant will contain two 1,000-horse-power Hamilton-Corliss engines, to run four 500-horse-power electric generators. There will be three additional boilers with the Jones underfeed stokers. The cost of the building and fittings will reach \$100,000. The Eighth street electric plant, to be erected at Depot street, near Eighth, will cost \$200,000. It will have four 1,000-horse-power engines and eight 500-horse-power electric generators and seven large boilers, furnishing 500-horse-power of steam each. The boilers will be heated by forced draft.

## TRAMWAYS INSTITUTE MEETING.

A general meeting of the Tramways Institute of Great Britain was held July 5, at the Holburn restaurant, London. The election resulted in the choice of W. J. Carruthers Wain as president for another year. A paper was read entitled "The Soulerin Brake." This brake is designed for trains and is hardly applicable to English tramways at present.

T. Arnnull, C. E., of Birmingham, read a paper on "Permanent Way Repairs," which was of practical value, and was followed by an animated discussion, we are reminded that our English friends are about in the position in which we were some eight years ago by the presence on the program of two paper relating to the care of horses. Only

one of these was read, however. It was entitled "Patent Food for Horses," by F. Stiel. The question of "Roller Bearings for Tramcars" was discussed at length by F. Purdon. He stated in introduction that the cyclist, who has been put in much the same position as a horse, but who has the advantage of being able to speak and demand alleviation, very soon discovered the advantages to be derived from roller bearings, and the universal adoption of ball bearings for cycles is the result. The ball bearing, however, admirable as it is for the light weights carried on the cycle, has never succeeded under heavy loads, owing mainly to the fact that all the weight is carried by only one or two balls at any moment of time, and the balls only touch the races or ball paths on a point, the result being that either the balls crush or the races are indented.

The conditions of a good roller bearing are severe. Sufficient bearing in lineal inches must be provided to bear the weight. The rollers must not move laterally and must remain exactly parallel with the journal. The rollers must not grind against one another, as balls in a ball bearing, and no sliding or scrubbing must take place between any parts of the device. The journal must not move laterally under the load, as this would set up a spiral movement of the rollers. Mr. Purdon describes a bearing which he says fulfills these conditions. A table was given, showing the results of tests on starting effort and ease of traction with cars having plain and roller bearings. It was found that it took less than one-sixth the amount of horizontal effort to start the roller bearings than it did the plain. For the ease of running test, cars were let run down a grade onto a level, the distance run being noted. The results were found in favor of the roller bearing in the same proportion as before, viz., 6.39 to 1.

To test the wearing qualities of the device a car was put on the Morecambe road in February, 1894, where it ran 3,000 miles without perceptible wear. Holroyd

Smith, engineer of the Blackpool corporation electric tramways, then became interested in the bearing and a set was put on an electric car for the purpose of comparing with other cars as to current consumption. Mr. Smith reported that the current consumption was fully thirty per cent less with the roller-bearing car, and roller bearings have been ordered by the directors for two new cars now being built. The cost of the bearing is \$50 a pair, but this might be reduced for large quantities.

## TIPPING OF WOODEN BLOCK PAVEMENT.

The new bridge over the Elbe river at Magdeburg, Germany, has a roadway about 26 feet wide, with two street railway tracks in the center. The pavement consists of pine blocks 4.4 inch high and 3.2 inch wide, laid on a bed of 0.8 inch of asphalt. Owing to the presence of the railway, the travel over the bridge on each side was entirely in one direction, and the wear on the pavement was very great. After the blocks had been down five years a careful examination of them was made, and it was found that on the rising and level pavement the sides of the blocks which the wheels passed over first were not worn at all, but were pressed from 0.5 to 0.6 inch into the asphalt. The wear had taken place on the further side. On the falling part of the carriage-way on each side of the bridge the wear had been the opposite. The explanation offered is that the friction of the wheels shoved the blocks in the opposite direction to that of the vehicle, and the traffic was heavy enough to make this shoving of enough force to produce the results noticed.

## THOMAS NEVINS.

The principal in the late purchase of the Detroit street railways, so much and so long before the public eye, is an Irish contractor, of Orange, N. J. Four million dollars cash was the purchase price, with \$4,250,000 in bonds. An English corporation was also making a bid, but it was out manoeuvred by the Jersey Irishman. Thomas Nevins was born in Trim, County Meath, Ireland, and came to this country a penniless boy. While in Ireland, his great admiration was a beautiful estate with an old castle attachment, and he vowed if he ever got rich that estate should be his. He returned to Ireland last spring and bought it for \$300,000, and is now one of Meath's land magnates. Mr. Nevins made his millions as a contractor, working hard, early and late, for the success he has attained.

As in Chicago and other cities wherever the cable railway goes, it influences the naming of various small businesses. In New York this result can be seen along Third avenue and up in Harlem, where there are now a number of "cable" saloons, cheap restaurants and small shops. On the Bowery there is a "Cable Clothing Company."

## EX-PRESIDENT HARRISON ON THE INDIANAPOLIS FRANCHISE.

Citizens' Street Railway Company vs. the City Railway Company,  
No. 8866 Chancery.

The litigation of the franchise of the Citizens' Street Railway Company, of Indianapolis, has attracted national attention, and has involved upon both sides of the question some of the best legal talent of the country.

The present owners of the franchise, Murry A. Verner and H. S. McKee, the well known Pittsburg Street Railway men, contend that the franchise under which the Citizens' Street Railway is operated, is perpetual, while the city claims that the 30-year right expired January last (1894). The amount invested in the plant is somewhat in excess of \$5,000,000. The company's point in the matter is that the ordinance under which the system was inaugurated is simply permissive of the occupancy of the streets, but the right to perpetual occupation was derived from the State.

A competing company, known as the City Street Railway Company, claims the right to now occupy the streets under recently granted franchises, and merely asks the present company to remove 108 miles of track or be forced to sell out to the competitor. The animus of the case is, of course, the competing company, which is to profit in the matter, and however hidden this idea may be, the logic of events displays it clearly.

The McKee-Verner syndicate fights the case with a determination born of the knowledge of the immense loss, and are "thrice armed" because their quarrel is just.

Ex-President Harrison was one of the learned counsel employed, and his argument before Judges Wood and Baker, sitting as a district court, is not only a departure from the leading of his colleagues but a brilliant effort from a legal standpoint. Mr. Harrison's argument lasted four hours, and the fact that his fee was \$25,000 has attracted great attention in lay circles, although the results involved, in comparison, make it none too great.

General Harrison began by following the history of the Citizens' Street Railway system since its foundation in 1864, its growth and the introduction of electric traction. One point to be noted is that the present system occupies many miles of track under franchises which were originally granted from suburban towns now incorporated in the city boundaries, and many country roads which formerly the county granted rights over, are now in the city. Thus, although the franchises of the original citizens should be forfeited, no power could touch these others, and it is manifestly wrong to take a part or leave a part of the system useless by reason of forfeiting its connections. The counsel said:

"If the contention of our adversaries prevails we have a broken, disjointed series of tracks, the right to operate which is terminal at different times, and a system which fails entirely of the public purpose for which it was created. I am not intending now, however, to present an

argument, but simply to get before the court some facts which may illustrate the results of this construction or that of the laws under consideration.

The construction of these tracks has involved the expenditure of a very large amount of money—several millions of dollars. I do not know whether the total cost is disclosed in the evidence, but, in the very nature of things, it is a vast sum of money. The next fact I desire to state in this connection is that in connection with the construction and use of these lines, urban and suburban, there has grown up a public necessity that their use shall be continued and uninterrupted. The extensions of these lines are either upon the lines of the extension of the city, answering a demand for such service, or they are anticipatory of such a demand."

General Harrison also bore upon the manifest injustice to the citizens of destroying for a time the rapid transit facilities of Indianapolis, and referred to the great strike, when the courts were applied to for a receiver, in order to get facilities, and argued that the building of a new system of 108 miles out of hand would be an impossibility in a short enough time to still keep the city moving.

The counsel says further:

"Our position has been perverted to be a claim perpetually to exercise the right to operate cars on these streets without the imposition of any further reasonable regulations. That is not true. Our contention simply has been and is, that, under the law, the city council of Indianapolis is not vested with the power to prescribe such regulations, and especially any regulation that shall terminate our right to use the streets. In the State it exists; it exists so amply that we are not to construe it out of the law, but to keep it there. Not a power with limitations, but an ample, full, sovereign power to deal with the corporation."

What does a transfer from one company to another fairly involve? If the legislature had contemplated such a transfer what provision would have been made? Why, that the company having these structures in the streets should have its property appraised by some appropriate judicial process, and that, under a law providing for it, it should transfer its powers and its property to some one else. I call your Honors' attention to the fact that no provision is made in any law of the State of Indiana for any assessment of the value of the property. I ask your Honors to note the absence of such a provision and its result; for surely we will not impute to the legislature the intention that the property of one corporation thus located in the streets of a city shall be transferred, as the attempt has been made here, to another corporation, and the profit of this looting divided between the new corporation and the city. I will undertake to demonstrate to your Honors that is precisely what this speculative charter, that is represented by the defendant, means; that the street railway track of the present company is to be appropriated by the new company without compensation, and that the tribute from its tolls which this new company pays into the city treasury is a division of the profits made by the transaction.

I will show your Honors as I progress, that this negotiation bears on its face the confession of the city that it was dealing with a matter that it had no right to deal with, and that it took bonds from this new company—making an agreement almost champertous\* in its nature—that it would indemnify the city for any damages and would conduct the suit that was to destroy our rights at its own expense. How is this transfer to be brought about? Have we the right to take up our tracks? Judge Selden announced, in a case in New York (*People v. O'Brien*, 111 N. Y., 1), in support of his conclusion, that the franchise was perpetual; that these structures, when thus imbedded in the streets, became a part of the street and could not be removed. The most onerous method that can be adopted as against the public in the conduct of street railway companies is to attempt to enforce this idea of a limited term of years. If I construct a railway track in the city of Indianapolis and am limited to a term of thirty years, and at the end of that time must leave my expenditure in tracks to the city, what follows? I must, during these thirty years, levy such exactions on the public as will pay the interest upon my investment and pay the investment back in full before the end of the thirty years. Nobody would build a street railway unless he could do that. So that the public is burdened by every such successive limitation. The grantees of the franchise must not only get an annual interest on their investment, but must be able each year to make such contributions to the sinking fund as will discharge the whole investment before the end of the term. Now, if we are not entitled to take up these tracks, these gentlemen propose to enter into the occupation of them.

The defendants' (City Company) situation may be briefly stated. It is that it has no investment except in lawyers' fees—no investment of any sort but the cost of litigation.

General Harrison also clearly showed in several instances that the defendant company, the City Railway Company, expected from the outcome of the suit to force the Citizens' Company to sell at a low price, just enough above the price of scrap, to make it worth the while of the City Company to buy it, thus practically losing to the Citizens' any right to recover a first cost. He also asserted that no statutory provisions existed for the sale of property under such circumstances.

Judge Wood asked the question as to the precedent in the books as to sale of property under such circumstances and as to the action of court of chancery.

GENERAL HARRISON: "I desire to add to what I said orally this fuller answer to the query of Judge Woods:

If, under the statute, our right to operate a street railway is derived from the city, and was lawfully limited to a period of thirty years, upon what theory of equity jurisdiction can the court extend our rights to a longer

\*CHAMPERTRY.—The prosecution or defense of a suit, whether by furnishing money or personal service, by one who has no legitimate claim therein, in consideration of an agreement that he shall receive, in event of success, a share of the matter in suit. From early times this has been considered an offense and punishable.

period? Surely, there is no such power. Now, unless our right to continue in the use of these tracks can be held in exercise by the court beyond the limited time, we can get no value of them, save, first, by finding a buyer who can use them as they lie, or by taking them up and selling the material. The first value cannot be secured unless there is competition between persons having the right to use the tracks; but this court cannot open such competition unless it has power to control the legislative discretion of the board of works and the city council; and without such power how can this court restrain those bodies from giving to a new company the right to place tracks just where our unused tracks are. To protect our values you must not only prevent the use of our tracks by others, but you must prevent the city from requiring us to remove them. For, if we have only the right to remove them, or if we may be compelled to remove them, the scrap heap value only is left to us. You must not only say that no other company shall use our tracks without a valued compensation, but you must say in effect that it must use them; for, if they are not compelled to take and use them we remain as fully as ever in their power. In the Detroit case cited in the argument, Judge Taft held that as the law of Michigan limited the corporate life of street railways to fifty years, a city grant or license to use the streets, which went beyond the corporate life, was void, because there was no corporation to exercise it. The results were so disastrous and inequitable that when he fully realized them he suspended the final decree and appealed to the parties to make a compromise. He saw no way of escape through any power of the chancellor. But here your Honors have only to hold that the legislature of Indiana did not fall into the absurdity of attempting to provide for a perpetual public use through corporations having term limits as to the discharge of that use, and without making any provision for turning over, upon fair terms, to a successor, the appliances and structures necessary to the continued discharge of the use. Property rights, the public use, and the fullest control of the corporation are all secured by this construction.

\* \* \* \* \*

If a use that is perpetual, and a use that is developed by use, and becomes more imperative and necessary, is to be cut off, we had better not have instituted the corporate agency at all. There has been an enormous development since 1861; these street railways—as do the complainant's tracks—now connect towns. Our tracks connect West Indianapolis, Haughville, North Indianapolis, Irvington and adjacent towns, with the city of Indianapolis. Yet, some question has been made by our opponents as to whether this was a public use. My friend, Mr. Butler, said the other day that it was not. I said to him jocularly, when we adjourned, that I would suggest to Mr. Mason to instruct his conductor, when Mr. Butler attempted to take a car downtown after his lunch, to tell him he could not ride, that he would not carry him; and after he had walked down to the court-room I then wanted to hear him again on the question whether this company was discharging a public use, and whether



anybody who paid his fare and behaved himself had not a right to ride in these cars, just as on the Vandalia railroad. There can be no question about that. They are railways, and not simply as they have developed, city railways, but railways connecting adjacent towns. They are roads for the carrying of passengers and their ordinary baggage; and any citizen has a right, upon paying the fare, to ride upon them. I do not need to stop here to cite authorities to that; Mr. Winter has done that. In the State of New York, street railway companies were first organized, as I understand, under a general law providing for the organization of railways. Again, it has been held in Iowa that the general railroad law as to condemnations applied to street railways. In another case it is held that the law as to the consolidation of railway companies, so described, applied to street railways. But I should waste your Honors' time and my own, I think, if I talked any further upon the question whether this corporation discharges a public use; whether it is a public carrier of passengers and bound to carry any person who offers himself at the right place and pays the lawful fare. Now, that being so, what has been the policy of our State with reference to such corporations? Why, if your Honors please, steam railways—which, as I have said, are so much like these that the courts make them one in the interpretation of statutes that use the general term "railways," unless there are exclusive words—are declared to be perpetual. Does any one suppose that anybody, anyhow, would be permitted, in any agreement they might make with one of the steam railways, to insert a limitation that would break one of these through lines of railroad communicating between city and city? The State has made such corporations and their operation perpetual; and upon the theory that I spoke of, that they are to discharge a perpetual public use. The court will hold these corporations in due subjection to the law. They are to go on forever, because these towns are to go on forever; because business is to be done forever; because our people will be called from place to place by their pleasures, necessities or business forever. Now, this policy is not limited to railroads, though a railroad policy is all we need here. Every corporation in this State, so far as I have been able to find or now remember, except telephone companies, nearly all, at least, discharging a public use, have been granted perpetual life and operation, either expressly or by the failure to impose any limitation.

So argued Mr. Harrison that the analogy was perfect as necessary and no provision had been made by legislature for fixing the value of a street railway line thus to be sold, or even to lead to the winding up of the affairs of the company.

GENERAL HARRISON: "What kind of a city franchise to operate is one that has no validity at all except at the will of the State? I am discussing the question whether the legislature has given the power to the city to grant a franchise; and my argument is that it has not given the city the right to secure us the right to use the streets for an hour. My argument is that the legislature

granted the operating franchise, and not the city. The full power of amendment and repeal reserved to the State shows that it was not intended that the city should deal with the question of time at all. The power to grant a franchise implies power to make it good, according to the terms of the grant.

Now, if the intention of the legislature had been that this operating franchise should continue for such length of time as the several cities in which these corporations were organized might determine, can anybody tell me why the legislature did not say so? Why wasn't it said? Why were our adversaries left to all this toilsome effort to deduce that meaning?

In fact, the city ordinance was regulative. Once a road is built, it passes out of the power of the city, with no provisions for the limitations of the franchise.

In closing the case General Harrison said:

"Now, if your Honors please, I do not know that I can add anything to what I have said, either to add force or clearness to the propositions upon which I rest this case; and if your Honors will permit me to summarize a little I will close.

We have here a great investment; we have here a great system serving a public use, so necessary to the health, convenience and comfort of the citizens of Indianapolis that its stoppage for twenty-four hours is a calamity. We have here a corporation endowed by the State with the power continuously to serve that use and one which is thoroughly regulated by the State and may have any further burdens placed upon it that are suitable and reasonable. We have here a statute giving that corporation perpetuity. Any life short of that is a life shorter than the purposes for which it was created. It is an untimely end if it leaves the use unserved. We have here a proposition to cut off this use suddenly and effectually, and to turn over this property to a corporation that has manifestly been organized upon the theory that there was a carcass to be divided; that we had in the streets tracks that we could not get out of them, and that we must either part with the property by contract for a song or they would take and use it for nothing. Unless they are to take and use these tracks, a most distressing, inconvenient and unfortunate interval must elapse between the taking up of our tracks and the laying down of theirs.

And all this is deduced from a statute that has conferred upon the city a power to consent to three definite things. I know your Honors' familiarity with these terms. You never can construe "operation" to be included in any one of them. The distinction is sharp and clear; the statute must be rewritten to accomplish their purpose. Our interpretation of the statute gives full effect to every word used and provides for this use a company equipped to discharge it, subject to every reasonable limitation and duty that shall compel it to serve the public in the most efficient manner. Your Honors are invited to legislate; not to construe, but to legislate, and for the accomplishment of such purposes as I have inadequately and without passion attempted to describe.

And now, if your Honors please, I hope that in this discussion I have made good the purpose with which I started, and have not brought into it any suggestion that is not worthy to go with your Honors into the chamber of judgment, where the rights of my clients are to be decreed.

I am sorry that we have occupied for so long the attention of the court, and that, while these matters, wholly between parties, have been under discussion, other matters, involving large and exigent public interests, have also claimed your attention; that your minds have been distracted and your time somewhat withdrawn by events involving the peace and good order of the communities in which your Honors serve as judges. And yet, what a fine tribute to our institutions it is that, while these things are going on and mobs are threatening a few cities, the great, deep current, the peaceful, forceful flow of our civil order, is not staid for one moment; but the courts are administering the law between those who have invoked its aid, and the general peace of the Nation is scarcely ruffled."

The points made in the support of the contention of the company are regarded as specially strong and the people wonder that the idea never presented itself before. When the privilege was granted it was believed that a limitation had been placed upon it, and in all transfers, until the last, the purchasers supposed they were buying a limited right to the occupancy of the streets. Every company has, therefore, endeavored to get an extension from the city council, and this has long been an issue in local politics, to say nothing of the liability and the corruption of the town officials. When the Chicago capitalists bought it they held out as an inducement that the system would be changed to electric traction, and did change several lines. The public sentiment, headed by a newspaper howl, was against it, and nothing of additional rights were brought forward. Legal counsel was sought by the McKee-Verner syndicate, and Harrison, Miller & Elam, of Indianapolis, opined that the franchise was perpetual. The ex-president was thus brought forward in the case to defend his opinion.

The matter will ultimately go to the United States Supreme Court, and the decision will be watched with great interest, as many companies have obtained what are at present believed to be limited charters, and the case will have more or less significant bearing upon all.

### STREET RAILWAY ETIQUETTE.

The officials of the North Hudson Railway Company were surprised to learn that it was one of the unwritten laws of their road that a conductor should treat his driver or motorman at the end of each trip, says the New York Sun. The company had two objections to this custom. One was that it injured the discipline of the road, and the other was a suspicion that the expense was in fact borne by the company. The consequence was an order that any employe caught drinking while on duty should be discharged.

### FIVE WORRIES IN THE LIFE OF A CONDUCTOR.



There once was a young college freak  
Whose transfer was punched on the cheek  
Without a mustache,  
It made him so brash  
That he hit the conduc. on the beak.

A spinster of forty would take  
The cars for a ride to the lake;  
She asked for a transfer.  
The conductor made answer  
With one of the earliest date.



This "con" of Tom Lowry's one day  
Punched the nose of an innocent jay.  
Who easily saw,  
When he took it to law,  
As a crop it was better than hay.

At the end of the last weary mile  
Those sweet angel faces still smile,  
He is haunted by "mugs"  
And worried by thugs,  
So he rests "in the traces" awhile.

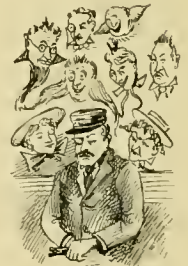

But at length he is driven to folly  
And quietly slips off life's trolley,  
And on that far shore  
He is met at the door  
By the angels who make things more jolly.

—Minneapolis Journal.

OUT OF SIGHT.—A rural visitor, after watching the New York cable cars for some time, finally volunteered this information to his friend: "Kain't ye see, b'gosh? Them things goes jist the same as the canal boats, only they ain't no room for the horses t' go on top, so they has 'em go in under th' road, an' when the feller at th' handles wants ter have th' gol durned machine go ahead he jist pulls on them 'ere things jist the th' same as th' reins used t' be, an' th' horses in under minds it and goes ahead."

### ANOTHER LIE NAILED.

The enterprising daily press has a story in the plates to the effect that the Binghamton Railroad Company, of Binghamton, N. Y., decorates with crape every car that in any wise contributes to a fatality.

General Manager J. P. E. Clark writes us that the item is the outgrowth of the imagination of some funny editor of a neighboring village.

"The employes of this company," says Mr. Clark, "have been granted the privilege of decorating the cars with emblems of mourning upon the occasion of the death of associate motormen and conductors. We allow this, as we believe it to be for the best interest of our road to create a bond of sympathy and good-fellowship between the employes of the company, and I am pleased to say that this feeling exists among our attaches. In case of trouble, severe illness or death in the family of any actively engaged employe, his associates come promptly to his assistance, a sentiment that we endeavor to stimulate."

### TESTING EYESIGHT OF MOTORMEN.

A few weeks ago a largely quoted item of general interest in the daily press was the testing of the eyesight of motormen on the lines of the Consolidated Traction Company, of Jersey City, N. J.

That good eyesight is as prime a requisite as a cool head is acknowledged, but few companies have taken the trouble to ascertain the capabilities of their motormen in this regard. The nerve and self possession of an employe can be tested only by real experience, while eyesight is simply a matter of trial at any time. The steam engineer has, perhaps, less need of perfect eyesight than a motorman of a city line, whose judgment of distances within a foot may mean damages or no damages to the company employing him. Then, too, the steam-road man has long stretches of track, where only the most ordinary care need be exercised in watching for trouble, whereas the motorman's longest clear run is a few hundred feet, with a criminally careless public crossing and re-crossing the line of traffic and swarms of daring children and foolish youths, making life one constant stretch of nerve. The eye of the motorman must therefore, be as nearly normal as possible.

General Manager Young, of the Jersey City Consolidated Traction Company, in view of the necessities of public safety, engaged a well-known firm of oculists to test the eyes of the employes. The tests were for diagnosing cases of myopia (near sightedness), hypermetropia (far-sightedness), astigmatism (indistinct vision), and color blindness. The oculists, A. Walter & Son, send Manager Young the following report:

"We have examined the eyes of 125 motormen in your employ, and find one case of myopia, and one cataract. One hundred and twenty-three had perfect sight and were given proper certificates after a rigid examination."

The tests show an unusual number of perfect eyes out of a given number, and without doubt Jersey City passengers will feel safer now when traveling in the cars or on the streets.

### HOW TO REACH ATLANTA AND THE AMERICAN ASSOCIATION.

The attendance on the Atlanta convention of the American Street Railway Association, to be held October 17, 18, 19, will be without doubt very large.

The city of Atlanta is one of the most pleasant, live and progressive towns in the south, and at no other place could the convention be more certain of a cordial welcome, such as only the hospitable south can offer. The advantages of Atlanta are many, but in none of them is it more marked than for the fact that to reach it affords a picturesque and interesting trip, neither tiresome nor too long.

The run from Cincinnati, over the Queen & Crescent Route, is one of great interest, and the ride is made on trains than which no more luxurious and elegant are found anywhere. The line lies through the famous meadows and woodlands of central Kentucky, where the people are widely hospitable, where live stock famed the world over is produced, and where the small cities of the "Blue Grass" are both picturesque and well-to-do. South of this the Cumberland plateau, with its coal mines and iron furnaces, furnishes the traveler with contrasting scenes. After passing Harriman the roads leads down the Tennessee Valley, past the famous battlefields into Chattanooga, and under the brow of Lookout Mountain. Leaving Cincinnati at 8 p. m. daily, the Queen & Crescent runs a solid vestibuled train to Atlanta without change, the entire train from mail car to sleepers going through direct to Atlanta. The train leaving Cincinnati at 8:30 a. m. daily, runs solid to Chattanooga, where direct connections are made for Atlanta.

From Chattanooga south these trains run over the tracks of E. T. V. & Ga. Ry. This route from Cincinnati is the only one offering a service of solid vestibuled trains, besides it is more than 100 miles shorter than any other line.

In Chicago the Q. & C. representative, W. A. Beckler, has his headquarters, 111 Adams street, and will be glad to afford any information or extend any courtesy to delegates or supply men.

W. C. Rinearson, general passenger agent, Cincinnati, will also be pleased to give any desired information or assistance.

THEY will all have to come to it finally. Electric traction is the only savior of non-dividend paying lines. The Compagnie Generale Francaise de Tramways, whose annual meeting took place recently in Paris, states that it has been compelled to substitute mechanical (electrical) traction for horse haulage at Havre, Marseilles, Nancy, and Genoa.

### A REVOLVING TRACK BROOM.

A revolving track broom, designed by G. J. Smith, master mechanic of the South Covington & Cincinnati Street Railway, has had a 30-day trial and has proved a practical success. As shown in a plan view in Figure 1, the frame is made of gas pipe, with bearings for the broom axles on the end. Motion is transmitted by a sprocket chain to the main axle which is connected through universal couplings to the broom axles at each end. The chain is driven by a sprocket wheel on the axle, and is thrown in and out of gear by an idler sprocket wheel just back of the axles. The brooms can be lifted  $5\frac{1}{2}$  inches above the rail. Everything is operated from

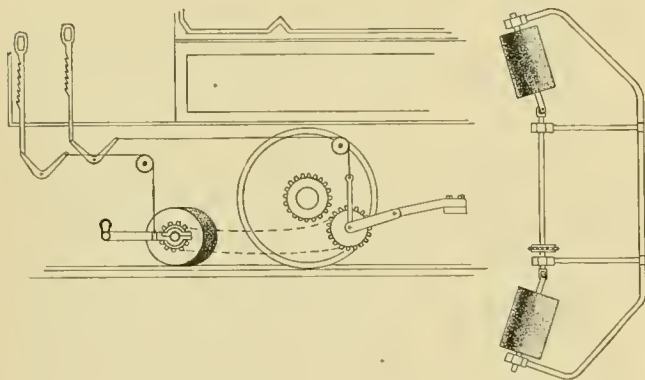

the front platform, as is shown in Figure 2. The brooms are 15 inches in diameter and 1 foot long. They are of steel wire with hubs of hickory 4 inches in diameter and 14 inches long with an iron band at the ends. The brooms revolve about  $1\frac{1}{2}$  times to one revolution of the car wheels. The driving sprocket wheel on the car axle is split, and cast in such shape that it takes the place of the axle collar which holds the motor in place. The use of the idler is necessary, not only to give the right direction of rotation to the brooms, but to throw them out of gear when not in use. A few cars equipped in this way and run with the brooms down for a trip or two on each route every day will help out the coal pile considerably.

### THE SOUTH STAFFORDSHIRE ELECTRIC TRAMWAY.

Alfred Dickinson, electrical engineer of the South Staffordshire, England, electric lines, recently gave an account of them and their performance before the Institution of Electrical Engineers.

The cost of running and repairs on the road is 8.12 cents a car mile, which is about the lowest figure yet attained in England for any kind of traction. This road, it will be remembered, is one of the only two electric roads in England. The one at Leeds is span wire construction after the American plan. The one at South Staffordshire, however, is on a very novel system, devised by Mr. Dickinson, and described in the REVIEW of

December, 1892. The trolley wire is not strung directly over the track, but along the side of the street on side pole brackets. The trolley pole is of a kind which will follow the wire when it is several feet away from the center line of the track.

### A ROPE WITH A RECORD.

Our readers will remember the engraving presented a few months ago of the Lang lay rope of the North Chicago Street Railroad Company, which ran ninety-eight days in the loop and through the tunnel at La Salle street. Another rope of the same make was taken out of service May 9 after eighty-eight days' run. The latter was a  $1\frac{3}{8}$ -inch cable, six strands, ten wires over seven, with a length of 9,760 feet.

The tunnel loop has four severe curves and carries all of the North Chicago trains around the loop. These cables were made by the well-known firm of George Cradock & Co., of England, and have given the buyers entire satisfaction.

### THE SWEET "LIMIT" SWITCH.

This circuit breaker is manufactured by the Sweet Electric & Manufacturing Company, of Grand Rapids, Michigan, and it is made adaptable to all circuits and locations, whether on the station switch-board, on building and motor circuits, or on a car. Its adjustment depends on the distance of the armature from the magnets, the pull on the armature being the same for one ampere as for five hundred. The arc is broken between carbons, the motion of which is very rapid at the time of breaking. The sensitiveness of the device is dependent on its excellent mechanical and electrical construction. The Sweet Electric & Manufacturing Company is having flattering success in placing it on the market, and owing to the general unreliability of fuses it will probably find a great demand for the switch.

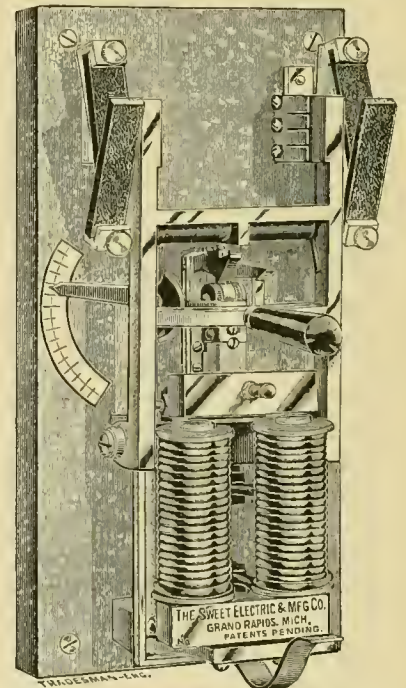

THE last horse car at Reading, Pa., was taken off June 27. The entire 30 miles of the Reading Traction Company's road is now operated electrically.

**THE INTERNATIONAL TRAMWAY UNION.**

The eighth annual assembly of the International Tramway Union will convene at Cologne, Germany, August 21, 22, 23 and 24. The exercises and discussions will be held in the hall Isabella, 29-33 Martin strasse, Cologne.

On Sunday, August 19, the clans will begin to gather, and at 8 o'clock in the evening the committee on credentials will hold forth. The next day an excursion to Remscheid and to Barmen-Elberfeld will be made, the party returning to Cologne in the evening.

The first session of the congress will occur Tuesday, the twenty-first, when general business will be transacted and the discussion of papers on permanent way and on metal ties.

Paving will also be discussed in connection with the latter subject. M. Fischer-Dick, of the Grand Tramway Company of Berlin, will report on the latter subject. At this session M. A. Moyaux, of Brussels, a prominent manager of Italian lines, will lead a discussion on passenger and freight traffic, including methods of inducing travel. Different kinds of tickets will also be considered.

All sessions begin at 8:30 a. m. and last to 12:30, and the afternoons will be spent in visiting plants and in social communion.

Wednesday will be devoted to electric traction, the most of the discussion pertaining to elementary subjects. M. P. Van Vloten, engineer, Brussels, will lead this meeting.

On Thursday, the twenty-third, horse-traction will have the floor, and the nourishment of horses (nourriture des chevaux) will be discussed by M. Baillot, manager of the tramways of the department of the North, Lille.

Car lighting and heating and the discussion of various steam and gas motors will occupy the twenty-fourth, finished by a business session and a banquet.

August 25 will be devoted to excursions to Dortmund-Hoerde and to Ruhrort-Essen, and at 9:03 Sunday morning those who are at liberty will depart to the World's Fair at Brussels.

**WHAT WE HAVE ALWAYS SAID.**

"There is no use in our trying to compete with the trolley lines," said a railroad man the other day to a reporter of the Philadelphia Record, as he glanced ruefully over some figures, which showed a decrease of \$40 a day in his company's receipts from suburban travel on a branch line since the opening of a trolley road. "We have to give too much to our patrons," he continued. "We provide handsome terminals, fine suburban stations, heat, water, light and a seat for every passenger, while the trolley lines furnish almost nothing but transportation. They furnish no stations; crowd the passengers in, so that many have no seat, and in that way manage to make money. We can't do things that way, and so I see no money for us in trying to compete with the trolleys. Of course, they can't touch us on long distance traveling, but in the near future I expect to see them absorb a large amount of our suburban travel."

**A NOVEL ADVERTISEMENT.**

The accompanying sketch shows how Smith's Coolierine is advertised in Houston, Tex. The banner is made of light wood, covered with canvas and properly lettered. It is then fastened to the trolley pole as indi-

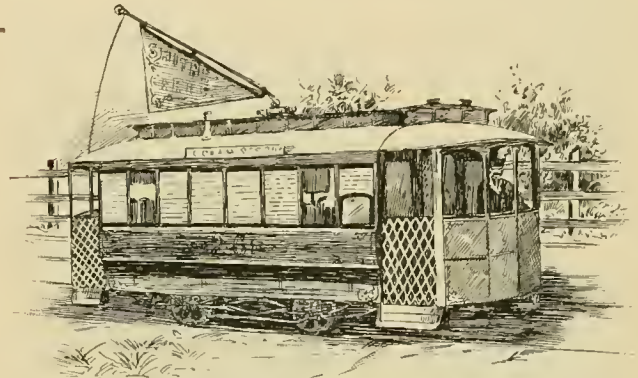

cated. President McKinney, of the Houston City Railway, writes us that the scheme was very effective, and netted the company \$75 a month for its use on all forty-seven cars. Mr. McKinney improved upon the Denver idea in making the banner.

**RECEIVER FOR THE MADISON, WISCONSIN, RAILWAY.**

The situation at Madison, Wisconsin, is not unlike that of several other places of about the same population, and is due not altogether to a depression in business, but partly to an over issue of bonds and stock. Madison is a beautiful city of about 15,000 inhabitants, and while not a manufacturing place is, as is well known, an educational center, which in times of business depression is really in favor of the road, as riding is less affected than in industrial towns. The road is stocked for \$75,000 and bonded for \$150,000, which is largely in excess of what the property should properly be called upon to stand, as it includes but eight miles of track, on which are operated eight motor cars. Necessary extensions that had to be made during the past year, and a large amount of paving which the city required the company to do, contributed to the result. Earnings last year are reported to be \$41,000, and \$225,000 securities are more than a property which could be duplicated for probably less than \$150,000 should be called upon to support. Track, rolling stock and motive power are all reported to be in excellent condition.

LONDON, ENGLAND, is to have a new electric railway. Work on a line between the city and Waterloo station has been commenced by the contractors, John Mowlem & Co., of Grosvenor Wharf, Westminster.

A CARDIFF company has gained the tender for working the Newport, England, tramways at a figure of \$9,300.

## ELECTRIC JOURNALISM IN ITALY.

We are glad to be able to present to our readers this month a portrait of Dr. Angelo Banti, the distinguished Italian electrical authority, and the editor of that bright review *L'Electricista*. Dr. Banti sends the REVIEW a copy of his brochure on *Electric Motors with Rotating Magnetic Fields*, a book of 82 pages, 7½ by 10 inches, and one of the finest specimens of European typography which it has been our pleasure to behold. It is divided into seventeen chapters. It reviews the history of polyphase transmission in a masterly manner, and describes the principal installations of this type in the last detail. It is eminently a scholarly production, and while not profusely illustrated, the text is elucidated by many diagrams and a few engravings. The book comes from the Elzevir press, Rome.



DR. BANTI.

## IMPROVEMENTS IN NUTTALL DEVICES.

The R. D. Nuttall Company, of Allegheny, Pa., has made some important improvements in its extensively used trolley base, and has also introduced a new steel

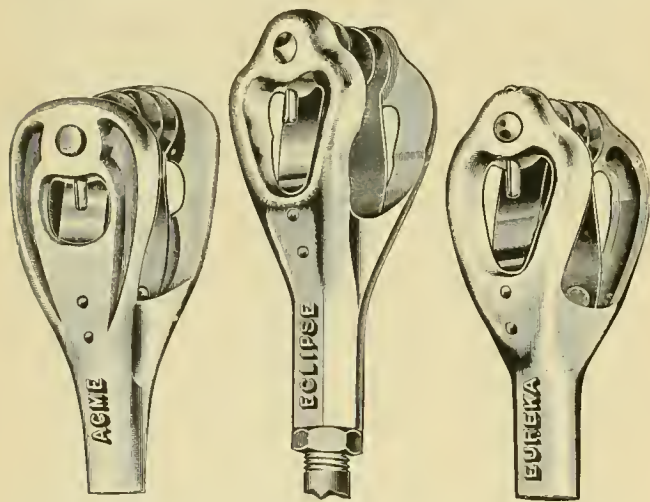

pole, malleable and brass harps, and brass trolley wheels. The foot of the new trolley base has been made stronger and arranged to catch any surplus oil that may drip from the swivel. The swivel pin has been enlarged, both in diameter of pin and diameter of shoulder. Where chains were formerly used, solid rods have been put in, as chains

were found to stretch. Two short springs, 9⅝ inches long, are now used in place of one 19¼ inches, as it was found that short springs could be tempered better than long ones. The pole has been made much stiffer and but little heavier than the former pole. It is a seamless steel tube, having a continuous taper from 1½ inches at the large end to 1⅛ at the small end. This pole was designed especially to overcome the difficulty sometimes experienced with very low trolley wires, of having the pole bend so that it strikes the wire. The Acme, Eureka and Eclipse harps, in brass or malleable iron, are all designed to avoid any chance of catching on the wire, as they have no projections. There is ample clearance for the wheel on the sides of the harp and the contact springs are so buried that it is almost impossible to cut them. The U shaped groove in the shank is to insure a clearance between the harp and wire when the pole is horizontal.

## CAPTAIN ALLEN TINDOLPH.

Captain Allen Tindolph, president of the Vincennes Street Railway Company, of Vincennes, Ind., died July 27, after a long and painful sickness, at the age of 52.

Captain Tindolph was one of the most prominent and public spirited citizens of Vincennes and was engaged in many enterprises. He was born in Crawford county, Illinois, in 1842, but emigrated to Texas with his family in 1858. The family returned to Crawford county in 1860 and young Tindolph completed his education by a business course in Chicago. During this time Mr. Tindolph not only was required to sustain himself, but the younger members of a large family. His first business, properly speaking, was as a Wabash river pilot, from which position he rose to be captain and owner of a boat. For twenty-five years he made steamboating on the Wabash his life-work, and acquired a large fleet—the best on the river. During this time his home was at Vincennes, and the captain with his fleet did, perhaps, more to bring the town into prominence than any one man. He retired from active work in 1889 and assumed the postmastership of Vincennes. He was also made president of the Second National bank and of the Street Railway Company, in which he was a prominent owner.

Captain Tindolph left a widow, two sons, and a daughter to mourn his loss. One of the sons, Frank Tindolph, is superintendent of the Vincennes Street Railway. A large circle of friends and every citizen of his city regret his loss as that of a public-spirited, Christian gentleman.

A SOUVENIR of Portland and its suburbs has been issued by the Portland, Me., Railroad Company, according to a plan outlined in the REVIEW some time ago. It contains fine half-tone engravings of the principal buildings and points of interest, and a well written account of them and how they may be reached by the street railway. It can not fail to attract strangers who are staying in the city and be a great help to them and accordingly to the railway.

## EMERGENCY AND WRECK WAGON SYSTEMS.

### II.

The wreck wagons of the Metropolitan Traction Company's system, in New York, are made by Gleason & Bailey, of Seneca Falls, New York, and are similar in construction to the patented fire insurance patrol wagons built by the same company, and in service for the Board of Underwriters of New York. Unlike an ordinary wagon, the men enter from both rear and sides, instead of from the end of the body of the wagon only. The seat runs the length of the center of the wagon, and the men ride back to back. This leaves room for a more spacious tool box under the seats. Under this long box is a false bottom, forming a long locker for carrying poles or any long tools. Back of the driver's seat are wrought iron saddles with straps for holding horse blankets. A locomotive swinging alarm bell is hung under the foot board. The foot piece of brake extends across the foot board, so that the driver can work it from either side or with both feet. The front wheels are 3 feet 2 inches in diameter, and the rear 4 feet 2 inches, with  $2\frac{1}{2}$  by  $\frac{3}{4}$  inch overlapping round edge steel tires. The axles are  $2\frac{1}{4}$  inch, having bronze nuts, secured by a linch pin, as is the regulation style of the New York fire department.

The springs are extra oil tempered, and made up for the purpose in strict proportion to the load to be carried. The body of the wagon is 11 feet 8 inches long, 5 feet 4 inches wide, and 19 inches deep. Over all wheels there are substantial metal mud fenders, and handsome brass hand railings surmount the wagon body. The steps are all covered with corrugated rubber matting. Bulls eye tubular lanterns, with patent wind shields, are hung on either side of the seat. These lanterns are provided with non-heating handles, so that they can be taken off the wagon and used around the wreck. Nearly every feature in the equipment of these wagons is novel and designed specially for the service.

Each wagon has, besides the other wrecking tools, eight pairs of shear legs, for elevating the hose over the track in case of fire. The guys for these shear legs are attached either to lamp posts or to iron pins driven into the pavement.

On electric roads the requirements are somewhat different, as the trolley wires require a good share of the attention. It is also generally possible to get cars around a blockade by another route, whereas this is impossible with the cable. Therefore the electric road systems have to be planned with special reference to electrical troubles, and special attention must be given to fires.

The Brooklyn, N. Y., system has fire alarm strikers at all of its emergency wagon stations, and whenever an alarm turned in shows that the fire is in a place where it affects the trolley or feeder system, the wagon makes the run and takes position inside the fire lines, ready to follow instructions from the proper fire department authorities if it is necessary to remove or cut out wires. If the

fire is a large one the general office is informed and an officer of the road at once proceeds to the fire and takes charge of the cars. The superintendent of the line department visits the fire in case his services are needed.

The territory covered by the West End Street Railway, of Boston, is divided into six emergency districts. The emergency crews are a part of the line construction and maintenance department, and are under the immediate charge of the superintendent of that department. The crew consists usually of a foreman and four men, conveniently located in quarters especially arranged for their occupancy. They are on duty day and night.

The equipment at each station consists of a pair of horses, suspended harnesses, tower and emergency

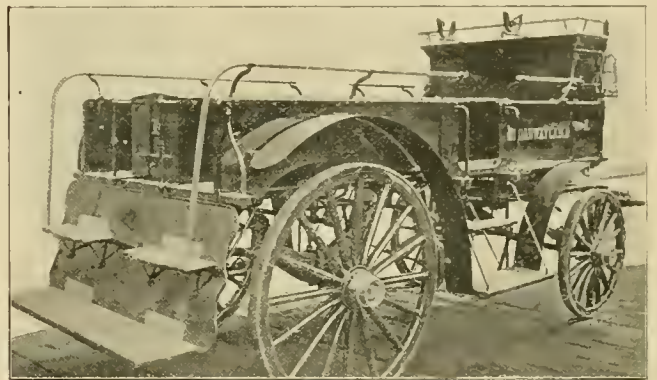

BROADWAY WRECK WAGON.

wagons, and all the necessary tools for the work of repair or removal of overhead lines, and the handling of disabled cars. A fire alarm tapper and telephone are located at each station, and the crews respond to all fire alarms and to telephone calls for any trouble with lines or equipment within their respective districts. Each man wears a numbered badge, in order that he may be distinguished from the employes of other electric companies. In addition they must wear the fire department badge. In the event of large fires, one or more crews are called from other districts to assist the crew in that district. Crews at fires are under the orders of the fire department officers.

The organization has done excellent service and is on the scene almost as soon as the fire department. General Manager C. S. Sergeant is certainly to be congratulated on having arranged so efficient a system. The men are especially selected for this duty, and carefully instructed regarding the methods of emergency work.

The Terre Haute Street Railway makes a practice of sending out a special car with hose jumpers to put on the track in case of fire. In a small place this is practical and generally quicker than sending a wagon.

It seems to be a doubtful honor to be a Milwaukee alderman, at least the News of that city says: "Pay your way when you ride on the street cars and be a man, even if only an alderman. There is no office so lowly that dignity cannot be added to it by the uprightness of the occupant."

## TIME TABLES AND TRAIN SCHEDULES.

How the Great West End System Gives Bostonese Cars on Time.  
The Complete System of John H. Hildreth.

PART II.

The mileage of the West End street railway of Boston, within its corporate name, includes nearly 300 miles of line and operates more than 2,000 cars. To keep these vehicles at a proper distance, and to regulate their speed and headway, is the duty of the Department of Routes and Time Tables, of which John H. Hildreth is the superintendent.

It was premised in our previous article (see June STREET RAILWAY REVIEW, pages 340-341) that three propositions are found upon which the constructor of the time table must build his work. They are, namely:

1. Justice to the public—frequent cars at rush hours and on holidays, and convenient intervals, neither too long nor too short, at other times.
2. Justice to the employes, that hours of labor may be as consecutive as possible, and equally distributed as to length of time.
3. Justice to the company, that no unnecessary cars be run, and that the maximum passengers may be car-



J. H. HILDRETH.

is operated under the division system, as in steam road practice, and thus the duties are divided and the immense system more easily managed, both as regards discipline and mechanical operation.

It is the local condition that governs so largely the arrangement of time tables, and Boston is no exception to this rule. It is Mr. Hildreth's experience that special time tables should be run on holidays, a different schedule for each one, as on no two such days is traffic found to be the same. While the same number of trips might suffice, they require an entirely different arrangement to bring about satisfactory results.

"It may not be a fact in all larger cities," says Mr. Hildreth, "but in Boston the street railway passenger traffic varies from day to day on some lines to such an extent as to require special treatment." The time table on these lines is not reconstructed each day in its entirety, but the "quick" headway (see below) is shifted an hour or so either way, morning or evening, as the business indicates. To this phase of car movement particular attention is devoted, as it often saves the running of extra trips. For heavy traffic lines a "pleasant" and a "stormy weather" table are provided, with the trips so arranged in the early part of the day, that a swing from one table to another can be readily made. To predict what the weather for the next day will be is often beyond the capabilities of the signal service of the United States government, to say nothing of the superintendent's less scientific methods. Even in the same day local weather changes, such as a shower, thunderstorm, or veering of

MEDFORD SQUARE TO SCOLLAY SQUARE  
MARCH 24, 1894---VIA WINTER HILL---MEDFORD CAR HOUSE  
ROUTE NO 645

CONDUCTORS				MOTOR MEN			
HOURLS	MINUTES	IN	OUT	HOURLS	MINUTES	IN	OUT
6:05-7:35	9:20-11:05	Z		2:35-4:20	Z		
6:20-7:50	9:35	Z		1:05-2:50	4:35	Z	
6:35-8:05	9:50-11:35			3:05-4:50			
6:50-8:20	10:05	Z		1:35-3:20	5:05	Z	
7:05-8:35	10:20	Z		1:20 X 3:35	5:20	Z	
7:20-8:50	10:35	Z		2:05-3:50	5:35	Z	
12:05 X 1:50	4:05	Z		7:05 X 8:35	10:05		
12:35-2:20				6:05 X 7:35	9:05	10:35	

EXTRA IN A.M.  
9:05 --- 10:50

EXTRA IN P.M.  
6:35-8:05-9:35

NOTE TRIPS MARKED X MEANS TAKE OUT CAR  
" " Z " PUT UP CAR

ALL OTHER RELIEFS AT CAR HOUSE COMING OUT

ried, comfortably, of course, with the minimum number of cars.

Mr. Hildreth in his arrangement of time tables follows this general rule, which may be stated.

"Let enough trips be incorporated in the time table to arrange for ordinary traffic, leaving to the different division superintendents and the foremen and starters immediately under them, the responsibility of retaining at their several headquarters a sufficient force of conductors and motormen to operate under telephonic direction from the Time Table Department, necessary additional trips for extraordinary occasions."

It may be stated en passant that the West End system

the wind may completely disarrange the best laid plans of superintendents. The time table shown herewith, scheduled for the Harvard Square-City Point line, is designed to be elastic enough to cover this daily change. It consists in reality of two tables. No. 1 is practically a ten minute service; No. 2, combined with No. 1, makes a five-minute headway, beginning at 10:59 A. M. after 12:56 up to and including the 7:46 P. M. trip, by changing the starting time of No. 1 to the threes, a three-minute service is obtained as the two tables merge. Having the headway changed at different times during the day, and arranged on distinct time tables, is advantageous to the men as well, because when once their day's work has begun



they are reasonably sure of finishing out, and are not therefore subject to the inconvenience of receiving part of a day's compensation, which would naturally be the result if all trips were arranged on one table and then left to the superintendent to reduce the trips in event of unfavorable weather. In computing time tables, the terms "running" or "quick" and "allowed time" are

10:05; 10:20; 10:35; 10:50; 11:05; 11:35 A. M.; 12:05; 12:35; 1:05; 1:20; 1:35; 1:50; 2:05; 2:20; 2:35; 2:50; 3:05; 3:20; 3:35; 3:50; 4:05; 4:20; 4:35; 4:50; 5:05; 5:20; 5:35; 6:05; 6:35; 7:05; 7:35; 8:05; 8:35; 9:05; 9:35; 10:05; 10:35 P. M. These put into a time table would appear as below in the Medford Square line. The "running time" is one hour and eighteen minutes; the

SUNDAY TIME  
HARVARD SQUARE TO CITY POINT  
ROUTE NO 756

NO 1747

MAY 20 1894

BOYLSTON ST CAR HOUSE

CONDUCTORS				MOTOR MEN			
7.34	[8.44]	9.54	[11.04]	1.04	[3.14]	3.24	[4.34]
7.44	[8.54]	10.04	[11.14]	1.14	[2.24]	3.34	[4.44]
7.54	[9.04]	10.14	[11.24]	2.44	[3.54]	5.04	[6.14]
8.04	[9.14]	10.24	[11.34]	2.54	[4.04]	5.14	[6.24]
8.14	[9.24]	10.34	[11.44]	3.04	[4.14]	5.24	[6.34]
8.34	[9.44]	10.44	[11.54]	3.14	[4.24]	5.44	[6.54]
12.14	[1.24]	2.34	[3.44]	4.54	[7.04]	8.14	[9.24]
12.44	[1.54]	5.34	[6.44]	7.54	[9.04]	10.14	[11.17]
12.54	[2.04]	4.54	[6.04]	8.04	[9.14]	10.24	[11.30]
EXTRAS IN A.M.				EXTRAS IN P.M.			
8.24	[9.34]	10.54	[12.04]	7.14	[8.24]	9.34	[10.34]
12.24	[1.34]			7.24	[8.34]	9.44	[10.44]
12.34	[1.44]			7.34	[8.44]	9.54	[10.54]
				7.44	[8.54]	10.04	[11.04]

NOTE: FIGURES ENCLOSED THUS [ ] DENOTE STARTING TIME OF RETURN TRIP

used. The latter averages about ten minutes more per trip than the former, and is used to cover any ordinary delay to which the car's passage may be subject in a congested street. In computing platform work this is included, except on last trips, when "running time" only is allowed.

So much for generalities.

As to the mechanical means employed, the basis of all

"allowed time," one hour and thirty to one hour and forty minutes. The car house is situated a quarter of a mile from the terminus, and the men in commencing their day's work either pull out a car or swing to one outward bound at the car house. Ten hours' duty done in twelve consecutive hours is supposed to constitute a day's work. It is, of course, impossible to reach the exact limit on very many lines, but the one represented is a fair illus-

SUNDAY TIME  
HARVARD SQUARE TO CITY POINT  
ROUTE NO 756

NO 1749

MAY 20 1894

BOYLSTON ST CAR HOUSE

CONDUCTORS				MOTOR MEN			
10.59	[12.09]	2.09	[3.19]	4.29	[5.39]	8.19	[9.29]
11.09	[12.19]	2.19	[3.29]	4.39	[5.49]	8.29	[9.39]
11.39	[12.49]	1.59	[3.09]	6.19	[7.29]	8.39	[9.49]
11.49	[12.59]	4.09	[5.19]	6.29	[7.39]	8.49	[9.59]
11.59	[1.09]	4.19	[5.29]	6.39	[7.49]	8.59	[10.09]
1.19	[2.29]	3.39	[4.49]	6.49	[7.59]	9.09	[10.19]
1.29	[2.39]	3.49	[4.59]	6.09	[7.19]	9.19	[10.29]
EXTRAS IN A.M.				EXTRAS IN P.M.			
11.19	[12.29]	1.39	[2.49]	3.59	[5.09]	6.59	[8.09]
11.29	[12.39]	1.49	[2.59]	5.59	[7.09]		
				12.56	[2.06]	3.16	[4.26]
				1.06	[2.16]	3.26	[4.36]
				1.16	[2.26]	3.36	[4.46]
				1.26	[2.36]	3.46	[4.56]
				1.36	[2.46]	3.56	[5.06]
				1.46	[2.56]	4.06	[5.16]
				1.56	[3.06]	4.16	[5.26]

NOTE FIGURES ENCLOSED THUS [ ] DENOTES STARTING TIME FROM OTHER END

calculations, as everywhere, is the trip sheet. By this observation it is determined what headway is required on the line.

Let it be assumed that the following trips are needed: Starting at 6:05, 6:20; 6:35; 6:50; 7:05; 7:20; 7:35; 7:50; 8:05; 8:20; 8:35; 8:50; 9:05; 9:20; 9:35; 9:50;

tration. It furnishes a full day's work to nine crews, eight regulars and one regular extra.

If it is desired to make the headway on this line more frequent, it may be done by adding two extra trips per hour. It is as tabulated a fifteen minute headway in the morning up to 10:05; by the addition of two trips an

hour, the headway is reduced to ten minutes, or the 6:05 train starts at 6:05, the 6:20 at 6:15, the extra at 6:25, the 6:35 at 6:35, the 6:50 at 6:45, the second extra at 6:55, the 7:05 at 7:05 and so on until the line is sufficiently supplied. On reducing the headway the process is reversed.

The time tables for each division are thus framed and alterable by the rules set forth. The tables for the entire system are printed, by the way, in the employes' organ, the Echo, mention of which has been made in these columns.

THE HOFFMAN BONDING DEVICES.

The patents on a number of important bonding devices have been obtained by A. Hoffman, of the Milwaukee Street Railway. Mr. Hoffman has had the satisfaction of seeing his bonds adopted by the Milwaukee Company and of having numerous inquiries from other companies. He is now ready to sell the right of manufacturing these devices to companies wishing to use them. They can be made with the ordinary facilities at hand in any street railway town.



FIG. 1.

The patents cover the use of a fish plate covering the bond wire. The new form of angle bar recommended for this purpose (Figures 1 and 2) is as strong as the ordinary form and costs only five cents more.

It can be made adaptable to any kind of rail.

Its use is not restricted to Mr. Hoffman's bonds, as rights to use it with any bond will be granted. It protects the bond from mechanical injury, keeps it from contact with the soil, and most important of all enables the use of a very short bond. This latter point may be



FIG. 2.

the source of quite a saving in copper where heavy bonding is necessary. If desired, the space between the angle bar and rail may be filled with pitch. The Hoffman bond for heavy work is the result of a discovery

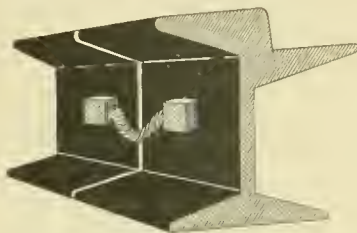

FIG. 3.

by Mr. Hoffman of a method of casting copper so as to

be able to cast copper rivets to the ends of flexible cable. These rivets are pure copper. In putting them in, the hole in the rail web should always be countersunk, as

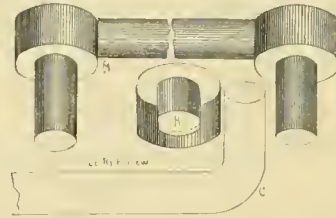

FIG. 4.

riveting can not be done well except in a countersunk hole. For lighter bonding the one in use at LaCrosse and described by us last year was devised. It consists of a single piece of wire bent at right angles at the ends and passed through

a brass washer to which it is soldered and which forms a shoulder so that the bond can be riveted.

SOME VERSE ON THE BOSTON SCHEMES.

[We beg the Boston Post's pardon for slightly altering the last two lines of the following production. Meigs' scheme is an elevated; the subway is the "popular" idea, and of Boynton's bicycle everybody knows. Ed.]

ELEVATED.

Will you walk onto my terrace?  
Said Joe Meigs unto the Sub;  
'Tis the queerest iron terrace  
You'll find in all the Hub.  
The way into my terrace  
Is up a winding stair,  
And I'll show you rapid transit  
A whirling through the air.

SUBWAY.

Will you come into my cavern?  
Said the subway to Mr. Meigs;  
'Tis the smoothest all-round cavern  
Ever went without its legs.  
The way into my cavern  
Is down a winding stair,  
And I'll show you rapid transit  
'Neath the city's thoroughfare.

BICYCLE.

Will you get on to my cycle?  
Said Herr Boynton to his pals;  
'Tis the swiftest, cutest cycle,  
It will beat Niagara Falls.  
And you can mount my cycle  
Without a winding stair,  
And I'll show you rapid transit  
With a minimum of scare.

WEST END.

Will you walk into my office?  
Said the West End to the rest;  
I am not a railroad novice,  
And I'll treat you to my best.  
See, it matters not at all  
Whether one or 'tother win,  
For unless we carry all  
We'll be roasted for the sin.

A STREET railway rate war is in progress at Savannah, Ga. The City & Suburban Railway cutting rates to 1 cent, 1 1/2 cents and 3 cents a mile, according to distance. George Parsons, of New York, is owner of the lines, and wishes to compel the purchase of the property by the Electric Railway Company. Ad interim, both roads lose money and nobody walks anywhere.

## STREET RAILWAY LAW.

EDITED BY FRANK HUMBOLDT CLARK, ATTORNEY AT LAW, CHICAGO.

*Guard Wires to Protect Wires of Telephone Companies.*

A telephone company doing an established business, and having its wires strung in the streets, by license of the city, may have *mandamus* to a street car company thereafter licensed to use electric power on the same streets, to obey an ordinance requiring it to string guard wires to its trolley wire, in places where it must cross other wires, so as to prevent damage by its breakage, on a showing that relator is in special danger as to the life of its servants and the integrity of its property in case of such breakage, that breakage cannot be prevented altogether and that guard wires are the approved and only safeguard therefor.

In the opinion the Court said:

We are of the opinion that the facts set out in the relation are sufficient to entitle the relator company to the remedy asked for. The telephone company occupied the streets of the city with its poles and wires, and was in the safe and successful prosecution of its business, under the authority of law and "by the permission, consent and approval" of the City of Janesville. The defendant company afterwards sets its poles and extends its wires along the same streets, so that its lines frequently cross the lines of the relator, and in such near contact as to endanger the persons in its employment, and its property, and threaten the destruction of its business. Relator's wires are up in the streets, bearing sufficient electrical power to make telephonic communications, and the defendant crosses them in many places with its wires, bearing electrical power sufficient to propel the cars upon its street railway; and the first storm that comes may blow down the poles and wires of the relator and its wires come in contact with the wires of the defendant where they cross each other, and become charged with its dangerous currents of electricity, set fire to the buildings in which the telephone instruments are used, and injure other property, and the persons employed in the "Exchange" and other places, so as to endanger or destroy the business of the relator. Ought not the defendant to be compelled to adopt the above safeguards to prevent this threatened mischief or to withdraw its lines from the vicinity of the relator's wires?

Section seven of the ordinance of the city, dated October 10, 1892, imposes this duty upon the company using this "electrical power system" in all cases, and requires it to apply such safeguards, under a penalty.

It is claimed that said ordinance has only future operation or effect. In application to the case, section seven of that ordinance provided: "Whenever it shall be necessary to cross \* \* \* telephone line or lines or any wires used," etc. Has it not been necessary for the defendant company to cross these telephone wires or lines of the relator since the passage of the ordinance, and is it not now necessary to do so? Then the ordinance by its terms is applicable to this case. The ordinance is made to regulate existing things, and things which continue to exist, as the wires of the defendant cross the wires of the relator. Whenever at any time wires so cross, this safeguard must be applied. The ordinance

has a present and future effect. It is said these wires crossed before the ordinance was passed. This is true,—and they have continued to cross ever since, in violation of the ordinance. The ordinance does not prohibit the crossing of such wires. It provides the remedy for it as an existing evil, and requires safeguards to be so placed as to avoid the danger to person and property. It is not retroactive in any sense. First.—The ordinance is reasonable because it requires that to be done which in law and good conscience the defendant ought to do for the protection of the relator, whose established business it has endangered and disturbed. Second.—It is clearly sustained under the police power of the city.

There can be no question, at this late day, but that our municipal corporations may make all reasonable regulations for the location and use of electric wires in the streets, and require all reasonable safeguards for the same. The question is virtually so settled in this state by our own decisions. The relator is entitled to sue out the writ of *mandamus* to compel the defendant to properly place such guard wires as the proper safeguard in such a case to protect its rights and safety. The relator is especially interested in the defendant's performance of this public duty. It is admitted to be true that such guard wires so placed are the very best and most approved method of safeguard in such case. This then is a clear legal right to be enforced by *mandamus*. There is no adequate remedy in such a case except by the writ of *mandamus* to compel the respondent company to do what it is clearly right for it to do—and that the relator has the right to compel it to do. The penalty enforced would not cure the mischief.

It is said that no such damages have yet accrued. The relation very clearly shows that such damage is imminent and threatening, and the danger is all the time present. This might be sufficient ground for an injunction to restrain the defendant from crossing the wires of the relator with its wires—a much more violent remedy. The relator does not seek to prohibit such crossings, but only to make them safe. The relator is conducting its telephone business under constant fear and apprehension. Must it wait until the full extent of the apprehended consequences have been realized? The remedy sought is clearly the proper one.

(Supreme Court of Wisconsin. State ex rel Wisconsin Telephone Company vs. Janesville Street Railway Company, 57 Northwestern Reporter 970.)

*Electric Cars—Injury to Passengers by Electric Shock.*

In an action for personal injuries resulting from an electric shock, caused by contact with defendant's street car while alighting therefrom, evidence that the car was so charged with electricity as to injure a person by contact with any part, establishes a *prima facie* case of negligence.

It was proper to ask a witness, who testified that electricity could not be transmitted to a trail car in such quantities as to cause personal injuries, whether the metal railings around all of defendant's cars were not blistered by leakage of electricity; such questions not being objectionable as not being limited to the car by which plaintiff was injured and about the time of the accident, when the witness testified that he did not know of the injury till the day after it happened, or what caused the injury.

Colorado Court of Appeals. Denver Tramway Company vs. Reid, 35 Pacific Reporter, 269.

*Boy Riding on Platform at Invitation of Motorman.—Ejection by Conductor.*

The jury found specially that plaintiff had been injured by the wheels of defendant's electric car, that with other boys he went on said car by invitation of the motorman; that the conductor did not warn them off till after the car was in motion; that he used force, whereby plaintiff lost his hold and fell from the car; that the boys did not go on the car without leave after the same was in motion; that plaintiff was ten years and ten months old at the time, and under the circumstances, was not guilty of negligence proximately contributing to the injury. The complaint alleged that when plaintiff fell the car was going at a high rate of speed, and the court entered judgment for plaintiff, "all of the allegations of fact in the complaint herein, beyond those covered by the said special verdict, having been proved to be true by the undisputed evidence on the trial." *Held*, that the judgment was supported by the special verdict and findings, though the verdict did not specifically find defendant's negligence.

The complaint alleged that defendant's electric car was in charge of a motorman on the front platform, and a conductor; that the motormen had been used to permit boys of plaintiff's age (11) to ride on the front platforms and steps to a certain switch "for the purpose of inducing such boys to turn said switch" for said motormen; that while the car was stopped at a corner, plaintiff, with the permission of a motorman, "in pursuance of the custom mentioned," stepped on the lower front step for the purpose of riding to said switch. *Held*, that the complaint alleged no purpose of plaintiff to aid in operating the railway such as to make him a volunteer fellow-servant of the conductor.

Supreme Court of Wisconsin. Hart vs. West Side Railroad Company. 57 Northwestern Reporter, 91.

*Action by Mother for Causing Death of Son—Evidence of Inexperience of Person Killed—Gates on Platforms.*

The fact that the passenger killed had never before ridden upon an electric car was admissible in evidence, as tending to illustrate the cause of his failure to alight in safety; familiarity with this mode of transportation would qualify him to see and appreciate danger which he would not be likely to observe if he was wholly without experience. With experience, he might be chargeable with fault; without it, with none.

Although there may be no negligence whatever in the failure of an electric street railway company to have gates on the platforms of its cars for the purpose of

guarding against accidents to passengers, by preventing them from leaving the cars on the side next to the parallel track of the same company in the street, yet when the company has such gates on the platforms of its cars, not to keep them closed may or may not be negligence in a given instance, and this is a question of fact for the jury.

When a car stops because of an obstruction on the street, and not to afford any passenger an opportunity for getting off, the company is not responsible for the safety of the place as one for getting off, whether the car, at the time the passenger undertakes to do so, was in motion or at rest, the conductor not seeing the passenger or being aware of his purpose at the time the attempt to get off is made.

(Supreme Court of Georgia. Augusta R. Co. vs. Glover, 18 Southeastern Reporter 406.)

*Action for Personal Injury—Defective Street—Duty of Street Car Company to Repair.*

Appellee sued for injury sustained in consequence of defective condition of a street crossing at a place where two streets cross each other, along one of which streets the track of the appellant lay. It is familiar law in this state that the repairing of streets in a city is the duty of the city.

If a corporation accepts a grant from a city of the right to use the street in a special manner, and the grant is burdened with a duty, which it neglects, and injury results, the corporation would, no doubt, be responsible for the consequences of neglect of that duty; but for mere non-repair of a street in which it has a special privilege, it is not liable simply because it has such special privilege.

(Illinois Appellate Court. Rockford City Railway Company vs. Matthews, 50 Illinois Appellate 267.)

*Wagon on Street Car Track—Failure to Turn Out—Collision.*

Plaintiff driving in his wagon in a broad street, with his high wheels in defendant's street car track, was met and run into by a car. *Held*, that the Court properly charged that the car driver had a right to assume that plaintiff would turn out in time, but that if plaintiff failed so to do, and the car driver saw it, he must do what he could to stop his car and warn plaintiff off.

(Supreme Judicial Court of Massachusetts. Glazebrook vs. West End Street Railway Company. 35 Northeastern Reporter 553.)

*Person Injured by Iron Falling from Trolley Pole—Presumption of Negligence.*

In an action against a street railway company for personal injury, it was undisputed that an iron ear, which connected the trolley wire with a guy, broke and fell on plaintiff's head. There was no other evidence that the accident was caused by defendant's negligence. *Held*, that an instruction which recited the manner of the accident and asserted that, if nothing else appeared, the jury should find that defendant was negligent, was proper, and was not misleading, where the jury was further instructed to consider all the evidence.

(Supreme Judicial Court of Massachusetts. Uggla vs. West End St. Ry. Co., 35 Northeastern Reporter 1126.)

A STREET RAILWAY BAGGAGE SYSTEM.

Manager Mackenzie, of the Niagara Falls, Park & River Railway Company, of Niagara Falls, Canada, with his usual enterprise, has instituted a baggage car service on this interesting line. In form it is simply a box car appropriately lettered, and equipped with one motor. It



is run following the regular train which connects with the boat at Queenston for Toronto, and at Slater's Point for Buffalo.

All baggage is marked with label shown herewith. No other blank forms are used, and no receipts are given or taken.

A TRANSFORMATION SCENE.

Within the next few months the Limits station of the North Chicago Street Railroad Company will be so thoroughly changed that its old friends will scarcely recognize it. To begin with, the North Shore electric cars now connect at the barn, turning in at Dewey court and making a loop through and between the buildings. A new waiting room, or rather transfer room, has been built at this corner and before many days a substantial roof will cover the loop and the pavement in front of the building. An ornamental porch will probably be extended the whole length of the station and concrete walks will be added. The horse barns, of course, will be finally relegated to the dear, dead past, and 160 animals turned over to the peddler and the farmer. The Evanston Avenue horse line has call for but few cars, as the North Shore electric trains run north on Halsted to Evanston avenue, thus completing the line to Evanston from the Limits Station without change. The transfer arrangement, of course, is not in vogue on the Evanston electrics.

INFORMATION WANTED.

A Spokane, Wash., subscriber, writes for information as to enameling iron. He wishes the names of plants doing this business, books treating upon the subject and any information that may be afforded upon the process or material.

IN A STREET CAR.

But a feeble, bent old lady,  
With a faded, wrinkled face,  
Who along the car peered dimly  
To obtain a vacant place.  
Yet, as if with pulse electric,  
Instantly upon his feet  
Every man arose, to give her  
With a smile his empty seat

Kindly glances rested on her;  
Kindly hands were ready there  
To support her should she need it.  
For her soft and snowy hair  
Seemed an aureole of glory  
To those care encumbered men,  
As the mother love within them  
Woke to consciousness again.

Ah, there's nothing half so holy  
In this world of sin and woe  
As the love that blessed our childhood  
In the years of Long Ago;  
And a common chord of feeling  
Linked together man with man  
When the thought of home and mother  
Through that crowd of strangers ran.  
—Helen Chauncey, in Harper's Bazaar.

WATT-HOURS PER CAR MILE.

The accompanying table shows the consumption of power in watt-hours per car mile of motor cars under several conditions. They are not to be taken as in any sense comparative or as representing the average performance of any of the motors mentioned. They are simply the results of tests which have appeared in the REVIEW at different times, figured out in watt-hours per car mile. This way of expressing results is likely to be common in the future, on account of the increasing use of the Thomson recording wattmeters, made especially for testing street railway motors. It is really the only way of expressing the practical commercial efficiency of a motor. In making comparisons it is necessary that the speed, track and motorman be the same in all cases. Wattmeters are valuable chiefly as time savers, as they give the same results as ammeter and voltmeter readings, without requiring any calculation. In order to get the same results with ammeter and voltmeter as with a wattmeter, the voltmeter readings taken when the current is off must be discarded.

	Condition of tracks.	Average distance between stops.	Weight motor car.	Watt-hours per car mile.	Average Speed.
Two No. 3 Westinghouse motors, one trailer.	Good / Dry	.43 mi.	7½ tons	1,101	8.6
" " " " " two " "	" "	.43 "	7½ "	1,207	6.3
" " " " " " " "	" "	.36 "	7½ "	1,286	6.5
Sperry bevel gear motor, alone	Greasy	.60 "	6 "	1,160	10.0
" " " " " " " "	" "	.60 "	6 "	1,179	10.0
One No. 3 Westinghouse motor, alone	" "	.60 "	6½ "	1,202	7.8
Two " " " " " " " "	" "	.60 "	7½ "	1,233	12.0
" " " " " " " "	" "	.60 "	7½ "	810	10.0

The Coventry, England, tramways will probably be worked electrically, the Electric & General Contract Corporation having accepted the town's proposition.

ALLEN S. DEXTER.

The new sales agent for the safety clutch brake, of Philadelphia, has been known to the majority of street railway men of Chicago and the northwest as the manager for that section of the Binghamton Oil Refining Company.



A. S. DEXTER.

Allen S. Dexter was born at Albany, New York, and received both his general and business education at that city's schools. His first active business relations were with the drug trade in Albany, afterwards removing to Des Moines, Iowa, in the same line.

Just after the Chicago fire, of 1871, Mr. Dexter came to this city, and after a year's recreation, entered into the western management of the Binghamton Oil Refining Company, where he has since remained. His present quarters are at 70 West Lake street, and his telephone number is Main 1645.

Mr. Dexter has assumed the salesmanship of the Safety Brake as a side line for his usual business, and since both for fuel oil and lubricants he meets street railway men, the safety brake is a consonant adjunct. The best that can be wished Mr. Dexter is that the safety brake specialty may grow to the success that his other connection has attained.

ONE ON THE CONDUCTOR.

It was on a Cottage Grove trailer, and the blue coated executive of the car having made his collections was desperately attempting to flirt with a pretty girl whose curly head appeared from the second story window of an adjoining flat. Suddenly he was aroused to a sense of duty. His eagle eye caught a violation of the rule posted at the front of the car. In a moment he stood at the end of a middle seat and accosted a Hibernian gentleman who held an unlighted cigar in his mouth.

"Mustn't smoke here. 'Gainst rule," said the conductor.

"Who's smokin'?" replied the passenger.

"Well, you've got a cigar in your mouth."

"So have oi got fate in me shoes but oi'm not walkin'," was the retort, and the conductor dropped off the car and waited for the rear end to catch up with him, while the passengers all smiled a wicked little smile.

THE new board of rapid transit commission for New York has adopted the plans for an underground system has laid out by their predecessors. They then adjourned until September 25. This action was taken to bring the question of the city's construction of a rapid transit system before the voters at the election in November.

PENNSYLVANIA ASSOCIATION.

The executive committee of the Pennsylvania Street Railway Association met July 28. There were present: Robert E. Wright, Allentown; B. F. Meyers, Harrisburg. William Lanious, York; S. P. Light, Lebanon, and Richmond L. Jones, Reading.

The meeting was held at the offices of the Reading Traction Company, and preliminaries were arranged for an extensive meeting September 5, 6 and 7, at Reading. The headquarters will be the Neversink Mountain Hotel, and a large attendance is expected. An invitation is to be extended to all supply houses to send representatives and make a display of goods and specialties. The headquarters hotel is capable of accommodating several hundred guests.

THE MAINE STATE ASSOCIATION.

The Street Railway Association of the State of Maine will hold its midsummer meeting August 16, at 10 o'clock a. m. at Rockland.

The Maine Central Railroad has courteously tendered the association a special car, which will leave the Union station, Portland, Wednesday, August 15, at 1:20 a. m.

The Rockland, Thomaston & Camden Street Railway Company has arranged for a dinner for the brethren at the adjournment of the session. A number of the delegates will remain in Rockland over the sixteenth and take a steamer trip up the river to Bangor, reaching that city on the seventeenth, and going thence to Waterville.

Several important questions are to be discussed relative to legislative treatment of street railways, and an enthusiastic and largely-attended meeting is looked for.

The officers of the association are: W. R. Wood, Portland, president; E. A. Newman, secretary and treasurer.

ST. LOUIS RETURNS.

The usual quarterly report of the St. Louis street railroads has been published. The figures are as follows:

	Trips.	Passengers.
Baden and St. Louis .....	5,520	69,232
Cass Avenue and Fair Grounds .....	171,288	2,477,947
Citizens' .....	141,768	1,907,237
Jefferson Avenue .....	22,691	363,584
Lindell .....	314,848	4,165,553
Missouri .....	285,482	3,688,242
Peoples' .....	49,686	1,032,051
St. Louis .....	175,696	2,730,126
St. Louis & Suburban .....	32,500	2,083,361
Southern Electric .....	78,260	1,169,245
Union Depot .....	155,682	4,787,032
Totals .....	1,433,421	24,773,660

For the same period last year the totals were: Trips, 1,625,799; passengers, 26,186,742. This discrepancy of 2,000,000 is accounted for by the hard times of the last quarter and the shutting down of the factories.

J. M'ADAM & Co. have undertaken the \$100,000 extension of the Aberdeen, Scotland, tramways.

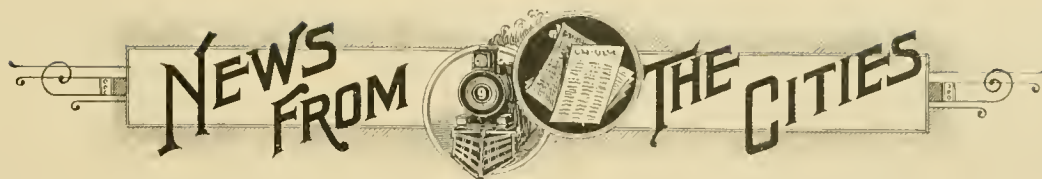

### Alabama.

BIRMINGHAM, ALA.—The Highland avenue & Belt Railroad wants a franchise for extensions and will probably get it.

### California.

SAN FRANCISCO, CAL.—Ground has been broken for the Page Street electric line of the Market Street Railway Company.

SAN FRANCISCO, CAL.—Col. F. H. Meyers, vice-president of the Alameda, Oakland & Piedmont Street Railway Company, Oakland, is dead.

OAKLAND, CAL.—G. K. Edwards, assistant superintendent of the San Leandro electric line, has resigned, and James Baker has been appointed his successor. Mr. Edwards was banqueted by his former associates.

SAN FRANCISCO, CAL.—A deed of trust issued by the Market Street Railway Company to the Union Trust Company of San Francisco has been filed. It is given to secure issue of \$17,500,000 bonds, which will be issued to pay off individual indebtedness of the several lines recently combined.

OAKLAND, CAL.—The rolling stock and personal property of the Piedmont Cable Railway Company has been sold at sheriff's sale on \$19,028 judgment in favor of the Oregon Improvement Company. John L. Howard, of the Improvement Company, bought nearly everything. The road is now operated by cars leased from Howard.

### Canada

QUEBEC, CAN.—C. St. Michel, president of the Quebec street railway, died July 23, at the age of 83.

HAMILTON, ONT.—The Hamilton & Dundas Dummy line will probably re-equip with electricity. C. J. Myles is lessee of the line and B. B. Osler is president.

TORONTO, CAN.—D. G. Stephenson, president of the Toronto & Scarboro Electric Railway, has disappeared. He was prominent in all public affairs and greatly trusted. His liabilities amount to \$50,000.

VANCOUVER, B. C.—New Westminster & Vancouver Tramway Company elects: President, David Oppenheimer; vice-president, B. Douglas; directors, J. A. Webster, Isaac Oppenheimer, and E. A. Wyld; secretary-treasurer, B. N. Smith.

NIAGARA FALLS, CAN.—The Niagara Falls, Wesley Park & Clifton Street Railway has been sold for \$25,000. The new owners of the road are Alexander Manning, ex-mayor of Toronto, Senator Aikins, Col. C. S. Gzowski, James A. Lowell, M. P., W. M. German, M. P., and others. Alexander Manning and Senator Aikins are the provisional president and vice-president respectively of the new company. The line will be changed to electricity as soon as possible.

### Chicago.

CHICAGO.—The city council passes ordinance for extension of L line from Market street to Wabash avenue, via Lake street.

CHICAGO.—The county commissioners are considering a franchise for an electric railway line between West Pullman and Morgan Park. The company is to be called the Morgan Park Electric Railway Company, for 20 years.

CHICAGO.—The Northern Electric Railway, which has a franchise for four miles of electric road from West Forty-seventh and Lake streets to Cragin, wishes proposals on entire equipment. Address Paul Dickenson, 68 Churchill street, Chicago.

CHICAGO.—T. Hackworth Young, manager of the railway department of the Transportation building of the World's Fair is dead. Mr. Young will be pleasantly remembered by all street railway exhibitors as a fair minded and accommodating gentleman.

CHICAGO.—The Chicago & Suburban Electric Elevated Railway Company is incorporated by J. M. Hannahs, Albert Wahl, F. W. Wolf, C. R. Matson, Benezette Williams and Michael W. Ryan—all well known men. The company wants to build an elevated loop through the center of the city.

CHICAGO.—The Yerkes syndicate has placed \$18,000,000 mortgage<sup>s</sup> running to the Illinois Trust & Savings Bank. Of this, \$15,000,000 is on the property of the Northwestern Elevated; \$1,000,000 on the North Chicago Electric Railway Company, and \$2,000,000 on all the property of the Chicago Electric Transit Company. It is given out that electricity will be used on the new L.

CHICAGO.—The Lake Street L Company will soon make a new issue of bonds to take care of \$1,200,000 floating debt. Work has started on the Humboldt Park extension.

The bonds of the Englewood & Chicago Street Railway are offered for sale with stock bonus. They are first mortgage 20-year sixes, registered with the Equitable Trust Company.

CHICAGO.—A. G. Goodman is said to be president of the Central Rapid Transit Company, and Z. S. Cornell, secretary.

CHICAGO.—The North Side Electric Street Railway ordinance is returned without signature by Mayor Hopkins. The mayor's suggestions for amendments were adopted and the ordinance re passed.

CHICAGO.—The Englewood & Chicago Electric Railway Company expects to have its main line to Morgan Park finished by winter time. The power house will be at Vincennes road and 87th street, and will cost \$100,000. The capital stock of the company is \$1,000,000 and the bond issue is \$2,500,000. The officers are W. H. Comstock, president; A. J. Whipple, vice-president, and F. E. Elder, secretary. Offices in New York Life building.

CHICAGO.—On August 20 the Chicago General Street Railway, 1032 Lawndale avenue, Chicago, will receive separate bids for: Two 450-horse-power Corliss engines; two 300 k. w. generators; three 200 horse-power boilers. These supplies to be set on proper foundations by the manufacturer. One engine, one generator and two boilers are desired for immediate delivery, the other unit to be delivered by May 1, 1895. The proposals will be considered with reference to: 1, quality and quantity of necessary attachments and fixtures; 2, place of delivery; 3, guarantee as to operation and repairs; 4, price; 5, efficiency. Proposals may be sent by mail or express to C. L. Bonney and should be marked boilers, engines or generators, as the case may be. An award will be made on such proposals as soon as the same may be considered. The prices should be made net to the company without commissions or expenses to outside agents.

### Colorado.

COLORADO SPRINGS, COLO.—The Colorado Springs Rapid Transit Company brings suit in federal court against the General Electric Company for \$20,000 damages, alleging failure of machinery.

DENVER, COL.—Organized: The Traction Construction Company, with headquarters in Denver and branch offices in New York City and Chicago, by Geo. E. B. Hart, William B. Dowd, both of New York City, and Henry A. Kirkham, of Denver, to build, construct and operate street railways, tramways, electrical and cable railways, with a capital of \$50,000.

### Connecticut.

HARTFORD, CONN.—The Hartford, Manchester & Rockville Tramway Company met at the office of M. S. Chapman and resolved to build the line.

NEW HAVEN, CONN.—Dovey & Company, limited, of Philadelphia, been given contract for completely rebuilding and extending and elec-

trically equipping the New Haven & Centerville Street Railway. A large car barn, but no power house, is to be built. The officers of the company which now owns the road are: J. Newton Pierpont, president, and W. M. Allyn, secretary. The stock is owned chiefly by E. J. Moore & Co., bankers, of Philadelphia, and Thomas C. Barr, the well-known street railroad magnate. There was an attempt about a year ago to bond the road for \$700,000, before it had been transferred by Cornelius Pierpont, its former owner, who received \$225,000 for it.

### District of Columbia.

WASHINGTON, D. C.—E. Saxton has been awarded the contract to build the cable line for the Columbia Railway Company. The cost will be \$600,000, and work will begin September 1.

WASHINGTON, D. C.—Metropolitan Railroad Company elects W. J. Stephenson as president; A. A. Wilson, vice-president; William J. Wilson, secretary and treasurer, and William E. Lowry, superintendent.

WASHINGTON, D. C.—W. F. Baker, of the Columbia Railway Company, notifies the commissioners that he is about to change the motive power of his line to cable. Plans and specifications are filed at the District building.

WASHINGTON, D. C.—The Chevy Chase & Kensington, Electric Railway Company has been organized to build from the terminus of the Rock Creek Electric Railway to Kensington. The officers are: Oliver R. Harr, president; Alfred Ray, vice president; W. Henry Walker, secretary and treasurer. Board of directors: Redford W. Walker, Reuben B. Dietrich, August Burgdorff, Oliver R. Harr, W. Henry Walker, Alfred Ray, Thomas R. Martin, William H. Mannakee, Alfonso Hart, Alexander M. Proctor and C. Parker Jones.

### Florida.

TAMPA, FLA.—John Jay Philbrick has gone to New York to close the deal with E. H. Gato for the Key West Street Railway.

KEY WEST, FLA.—Philbrick, Allen and others have been granted an electric franchise. Engineer C. Caves, of New York, will draw plans and specifications.

### Georgia.

ROME, GA.—Rome Electric Railway has been bought at Sheriff's sale, by Captain John J. Seay, for \$31,600. The line will be rehabilitated and operated.

COLUMBUS, GA.—S. A. Carter, president of the North Highland Street Railway Company, has been enjoined by the Columbus Street Railway Company against building parallel tracks.

### Illinois.

ALTON, ILL.—J. H. White has resigned the secretaryship of the Street Railway Company.

PEKIN, ILL.—A. F. Lee is local representative of a company that wishes to build a line here.

GALESBURG, ILL.—Judd Seacord is elected superintendent of the street railway and Henry Arnold assistant.

CHICAGO, ILL.—The Cicero & Proviso Street Railway Company ask a franchise through River Forest for 20 years.

MT. CARROLL, ILL.—McCarroll city council grants C. P. Woodworth a franchise for electric light plant for ten years.

PARIS, ILL.—Frank Fairbanks, of Terre Haute, Ind, is negotiating for the construction of a line here. Paris capital is also interested.

GALESBURG, ILL.—Street Railway Company elects: President, Robert Chappell; vice-president, O. F. Price; treasurer, W. Seacord; secretary, Henry Arnold.

WARSAW, ILL.—It is proposed by J. C. Hubinger, a capitalist of Keokuk, to extend his electric street car system to that city, and also to Carthage and Nauvoo, Ill. The plan is to cross the Mississippi by means of a high bridge at Keokuk, but Warsaw capitalists will use their influence to have the bridge built at this point, as a bridge charter has been secured.

SPRINGFIELD, ILL.—Organized: The Citizens' Electric Company, a \$60,000, by John McCreery, Fred A. Buck, L. H. Coleman, P. W. Harts and E. A. Wilson.

### Indiana.

TERRE HAUTE, IND.—It is proposed to extend the street railway to Highland Lawn Cemetery.

RICHMOND, IND.—Numerous cases are now pending against the Richmond Street Railway Company, alleging fraud against the promoters of the line.

MUNCIE, IND.—Chas. B. McCulloch, of Boston, has been granted franchises for electric railway to connect Red Key and Dunkirk villages near here. The line will be 3½ miles long and an electric light station will also be built.

NEW ALBANY, IND.—Louisville, Ky., and New Albany citizens are agitating the question of a new electric railway, and eastern capital has been invited to view the ground. The Commercial Club, of New Albany, is at the head of the matter.

HAMMOND, IND.—Telford Burnham and Rand, McNally & Company, project a new electric railway from this town to Chicago. Work will begin early next month. The proposed route is from the state line through West Hammond and Burnham, thence connecting with the Calumet electric line at 104th street.

SHELBYVILLE, IND.—The Shelbyville Mutual Telephone Company is incorporated at \$10,000, and has received a fifty year franchise from the city. The officers are: S. B. Morris, President; G. C. Pratt, vice-president; John C. De Perez, treasurer; John D. Pugh, secretary, and Chas. C. Caldwell, electrician. The construction and purchasing agent is Mr. Caldwell.

WASHINGTON, IND.—The following company is incorporated: The Washington Street Railway Company, of Washington, Daviess county, with a capital stock of \$50,000. The directors are Louis C. Fritch, W. W. Peabody, Jr., Ira G. Rawn and D. D. Carothers all of Cincinnati; William R. Gardiner and Charles G. Gardiner, of Washington. L. C. Fritch, of Cincinnati, and W. N. McMahan, of Washington, each has twenty-five shares, while the others have ten shares each.

### Iowa.

FORT DODGE, IA.—The electric railway franchise was voted to the local syndicate.

DUBUQUE, IOWA.—J. A. Rhomburg, of the Street Railway Company, will extend his line to Sageville (six miles) and make a summer resort.

SIoux CITY, IOWA.—John Peirce is after the Covington & South Sioux City Street Railway Company to add to the Consolidated system.

SIoux CITY, IA.—John Peirce has made an offer for the Leeds Electric Railway that will probably be accepted. The line will be extended and improved.

SIoux CITY, IA.—Hugh McMillan has begun suit against the Sioux City & Leeds Electric Railway Company to recover \$255.20 on account owing to the Detroit Electric Company.

SIoux CITY, IOWA.—John Peirce, of the Sioux City Street Railway Company, has secured control of the Riverside Street Railway. The new management will be called the City & Suburban and will not extend at present.

IOWA CITY, IA.—T. L. Seevers, of Oskaloosa, Ia., is planning an electric railway here. He is manager of the Muscatine Street Railway. A committee of Iowa City business men will look up the matter. They are: S. D. Cook, Lovell Swisher, C. S. Welch, C. F. Lovelace, and P. J. Regan.

### Kansas.

ATCHISON, KAN.—St. Louis Trust Company has filed a foreclosure suit against the Atchison Electric Street Railway & Electric Light Company, for a \$9,000 mortgage. A new company has been formed by Atchison capitalists by which the business of both concerns will be continued.



**KANSAS CITY, KAN.**—The Metropolitan Company asks for a franchise permitting it to connect its Chelsea Park line with the cable. This will complete a belt line.

**PITTSBURG, KAN.**—Chartered: The Pittsburg, Frontenac & Suburban Electric Railway Company, of Pittsburg. The capital stock of the concern is \$75,000. The directors are Samuel Barrett, Robert Robyn and A. L. Chaplin, of Pittsburg, L. M. Bedell, E. W. Minturn and Carl J. Simons, of Chetopa, and Robert Simons, of Westchester, Pa.

### Louisiana.

**NEW ORLEANS, LA.**—The council committee on street railways grants St. Charles Street Railroad Company right to use electricity. Similar action was taken upon a resolution authorizing the Orleans Street Railroad Company to use electricity as a motive power on the route it operates.

### Maine.

**LEWISTON, ME.**—N. O. Pope, New York, has bought the Lewiston & Auburn Horse Railway and will immediately change it to electricity.

### Maryland.

**BALTIMORE, MD.**—President Bowie, of the City Passenger Railway Company, says he will buy open cars for next year.

**RANDALLSTOWN, MD.**—The Randallstown, Harrisonville & Granite Rapid Transit Company has organized and elected officers as follows: President, Edward S. W. Choate; vice-president, Geo. E. Lynch; secretary, Dr. Henry J. Hebb; treasurer, Judge James W. Offut; solicitor, Z. Howard Isaac; directors, the above officers and R. P. Choate, Albert Webber, Aaron Weber, Henry C. Luttgerding. The company is negotiating with James G. Floyd, agent of the Barrows Electric Railway Company, to put in that elevated system.

**TANEYTOWN, MD.**—A meeting has been held here to get a permanent organization for the Baltimore-Gettysburg electric railway. A H. Zollickoffer was made president. The executive committee appointed is as follows: A. H. Zollickoffer, Dr. George T. Motter, Ed E. Reindollar, George H. Birnir, Dr. C. W. Weaver, P. M. Weist, of Taneytown; A. J. Lightner and Judson Hill Harney, John McFadden, of Philadelphia, Pa.; Dr. J. J. Weaver, Jr. and Ed. G. Gilbert, of Uniontown. Governor Brown has promised to meet the committee at an early date to consult with them.

### Massachusetts.

**ATTLEBORO, MASS.**—All legal action in the Attleboro, North Attleboro & Wrentham street railway matter has been postponed for an indefinite time.

**ATTLEBORO, MASS.**—The Attleboro, North Attleboro & Wrentham Street Railway has passed into the hands of the Union Traction Company, of Providence, R. I.

**BROCTON, MASS.**—The West Side Street Railway Company is organized at \$50,000 to build five miles of electric railway. The following will act as a board of directors until others are legally chosen by the corporation: J. C. Snow, J. E. Carr, P. K. Bacon, H. F. Woodward, Albert Barrows, A. B. Hastings and Edwin Keith.

**WEYMOUTH, MASS.**—A movement is on foot to build an electric line four miles long. The capital stock will be \$40,000 and the principal stockholders are Representative John Kelley, Judge James H. Flint, John W. Carey, H. F. Perry, F. A. Sulis, Francis Ambler, E. W. Hunt, A. M. Bachelder, and Thomas T. Bailey. It is intended to run cars by November 1.

**BOSTON, MASS.**—Boston Elevated Railway Company elect the following officers: President, General Charles A. Whittier; vice-president, George H. Towle; clerk of corporation, Fred C. Patch; treasurer, George A. Carney, Lowell, treasurer of the Lowell Institution for Savings; general counsel, Willard Howland; chief engineer, J. V. Meigs; consulting engineer, General Herman Haupt. They will build the new Meigs' system.

**BOSTON, MASS.**—Chartered: The Athol & Orange Street Railway Company. The road is to be run from the fair grounds in Athol to the square in Orange. The company is capitalized at \$60,000. The incor-

porators are E. R. McPherson, of Cambridge; C. H. Utley, of Brookline; John McPherson, of Medford; J. R. Nickerson, of Dorchester; F. O. Squire, of Arlington; J. Granville Young, of Boston; N. Sumner Myrick, of Boston; J. Albert Brackett, of Boston; W. B. Ferguson, of Malden; J. G. Shaw, of Newburyport; G. A. Butman, of Malden; T. H. Goodspeed, of Athol; Lucien Lord, of Athol; and J. W. Wheeler, of Orange. Of these, N. Sumner Myrick, of Boston, represents 586 shares and the others one each. The directors are: E. R. McPherson, W. B. Ferguson, N. Sumner Myrick, T. H. Goodspeed, Lucien Lord and J. W. Wheeler.

### Michigan.

**COLDWATER, MICH.**—It is proposed by solid citizens to build an electric railway to Union City via Girard.

**GRAND HAVEN, MICH.**—Chicago men are trying to get a line of electric railway built to Spring Lake and Highland Park. Water power is to be used.

**DETROIT, MICH.**—The old Detroit City Railway Company has filed a renewal of its \$1,000,000 chattel mortgage to Sidney D. Miller and Chas. M. Swift, trustees, with unpaid interest from July 1, 1892.

**ANN ARBOR, MICH.**—The Ann Arbor Street Railway Company has called a meeting of its stockholders for August 16, to elect directors and arrange with eastern parties to put the road into operation at once.

### Minnesota.

**WINONA, MINN.**—C. M. Putnam has resigned as superintendent of the street railway. He has not decided as to his future plans. Mr. Putnam has been here two years and is an efficient man.

**STILLWATER, MINN.**—Formal articles of incorporation have been filed by the Stillwater Electric Railway Company. The capital stock is \$75,000. The officers are Allen Curtis, president; E. P. Motley, vice-president; G. E. Waring, treasurer, all of Boston, and John C. Nethaway, of Stillwater, secretary.

### Missouri.

**KANSAS CITY, MO.**—J. J. Michael and Ferd Heim, Jr., ask for an electric franchise on the old Fifth Street Dummy line.

**LEXINGTON, MO.**—Joseph Tribble, who has bought the street railway line, will improve and extend it under his personal supervision.

**HANNIBAL, MO.**—The council grants the Street Railway Company right to extend to Frytown, a suburb. Work will begin at once.

**KANSAS CITY, MO.**—Judge Henry grants Receiver Robert Gillam, of the Northeast Electric Railway, right to issue receiver's certificates to buy equipment. Ten car bodies are wanted.

**ST. LOUIS, MO.**—After two years of hard fighting the South St. Louis electric line has succeeded in getting a bill through the council permitting an extension of its line to Cass avenue. For this privilege, however, the road is asked to pay the city \$10,000 per annum, or more by several hundred dollars than the syndicate pays for its five lines of street railroads.

### New Jersey.

**NEWARK, N. J.**—The board of works commissioners recommend passage of an ordinance compelling use of life guards on all electric cars on or before October 1.

**NEWARK, N. J.**—The Bloomfield car stables of the Consolidated Traction Company burned July 27. Loss is estimated at \$40,000. Six horse cars were burned and 30 were saved. The building covered 1½ acres and was 18 years old.

**ATLANTIC CITY, N. J.**—The promoters of the new electric railway are: L. C. Albertson, president; I. G. Adams, treasurer, and Joseph Thompson, secretary and solicitor. The directors are: L. C. Albertson, I. G. Adams, Joseph Thompson, John J. Gardner, Frank C. Somers, C. L. Cole and C. J. Adams. The corporate title of the company is the Atlantic City Street Railroad Company.

**RED BANK, N. J.**—The Monmouth Electric Traction Company has filed certificate of incorporation at Freehold. The incorporators are William W. Conover, Daniel H. Applegate, Charles B. Parsons, J. Enright, Jr., William T. Parker, Robert Avery, J. W. Robinson, George W. Palmer and Thomas R. Wooley. The capital stock is \$300,000, and it is proposed to build and equip a street railroad from Red Bank to Long Branch and return, making a circuit. The exact route has not as yet been decided upon.

**TRENTON, N. J.**—Certificate of incorporation has issued for the New York & Philadelphia Traction Company, capitalized at \$10,000,000. The plan is to build trunk lines to connect existing lines between the cities named. The New Jersey end of the enterprise will be built, operated and managed by two corporations. The Central Jersey Traction Company, with a capital of \$500,000, and headquarters at 2 Wall street, New York, and the New York & Philadelphia Traction Company, with the general office at Trenton. The officers and directors of the first named company are: President, Frank A. Macgowan, of Trenton; vice-president, ex-Sheriff E. W. Hine, of Newark; secretary, J. H. Baldwin, of Newark; treasurer, J. Darrah, of Trenton; directors, D. K. Bane of New York; W. H. Skirm, of Trenton; J. B. Reall, of Bloomfield, and J. C. McNaughton, of Philadelphia. This company is already incorporated. Mr. Macgowan is president of the New York & Philadelphia Traction Company, while the directors are said to comprise some of the best known capitalists and railroad men in New Jersey, New York and Philadelphia. The road will be built in sections, work to begin at half a dozen points, including Trenton.

### New York.

**WAVERLY, N. Y.**—The Waverly, Soyre & Athens Street Railway is in successful operation between the towns mentioned.

**SYRACUSE, N. Y.**—The Consolidated Electric Railway franchise has been extended to September 17, when the matter will be settled.

**NEW YORK CITY**—Coney Island & Brooklyn Railroad Company wants permission to change motive power from horse to electricity.

**HOMER, N. Y.**—A franchise has been granted to the Cortlandt & Homer Street Railway to run its lines by electricity. Work will begin at once.

**SYRACUSE, N. Y.**—“The syndicate,” says W. W. Kimball, “will build a new power house very soon. Work on the Solvay extension will begin at once.”

**NEW YORK CITY.**—The Metropolitan Traction Company has gained permission to build a crosstown line, a South Fifth avenue line giving rights through Broome, Sullivan and Watt streets.

**SCHENECTADY, N. Y.**—H. S. Cooper, general manager of the Schenectady Street Railway Company, is in the market for a good rail saw and a good track drill, both for use on old rails in place.

**LOCKPORT, N. Y.**—F. H. Reed, Wendell Goodman, president of the Lock City Electric Railway Company, and A. E. Wadratt are here trying to arrange for the completion of the electric railway.

**BUFFALO, N. Y.**—The New Buffalo, Kenmore and Tonawanda Electric Railway has begun operations. The officers of the company are D. F. Calahan, president; N. E. Mack, vice-president; G. H. Frost, secretary.

**BUFFALO, N. Y.**—The West Side Pleasure Railway, of Buffalo, is organized to build a switchback road at Elnwood and Forest avenues. J. C. Dick, of Pittsburg, is manager, and A. F. Schwerd, of Allegheny, is half owner. A pavilion, electric plant, cars, etc., are to be bought.

**UTICA, N. Y.**—The Utica Belt Line Street Railway has been reorganized by electing the following officers: President, John W. Boyle; vice-president, James T. Gardiner; treasurer, Charles W. Mather; secretary, Edw. Bushinger; executive committee, John W. Boyle, Charles W. Mather, James T. Gardiner. The line will be improved and extended immediately.

**YONKERS, N. Y.**—Incorporated: The North & South Electric Railway Company, to construct a street surface road about five miles in length in Yonkers, the northern terminus to be in the vicinity of Shonnard Place and North Broadway, and the southern terminus to be

the southern boundary of the city of Yonkers on South Broadway. The capital is \$50,000, and directors, William Delavan Baldwin, S. T. Hubbard, John C. Shotts, and T. H. Silkman, of Yonkers, and others.

### North Carolina.

**RALEIGH, N. C.**—The purchasers of the Raleigh Street Railway have obtained deed from the U. S. circuit court and elect officers as follows: President, Alf A. Thompson; vice-president, Dr. V. E. Turner; secretary and treasurer, T. H. Briggs; attorney, R. T. Gray; directors, A. A. Thompson, J. H. McAden, Julian S. Carr, V. E. Turner, J. H. Cutler, A. B. Andrews, Julius Lewis, Rev. B. Smedes and J. A. Jones. The capital stock will be \$25,000. The question of routes, extensions and electric lighting will be conducted at future meetings.

### Ohio.

**MARIETTA, O.**—This town wants a street railway and will entertain propositions. Good field.

**GEORGETOWN, O.**—Local capitalists are organizing a company to build a street railway to Higginsport.

**MT. VERNON, O.**—D. K. Bird, secretary of the Street Railway Company, was slightly injured by a fall from a train.

**DELAWARE, O.**—The city council grants street railway company a franchise on various streets for extension of the system.

**YOUNGSTOWN, O.**—The street railway officials call upon the city authorities for protection and will operate with non-union men.

**YOUNGSTOWN, O.**—The rumor that Manager A. A. Anderson is to resign is branded as false by the president of the company.

**WARREN, O.**—The franchise for the Warren-Sharon Electric line, last year granted to A. B. Mannix and associates, has lapsed by reason of the holders failing to do the requisite amount of construction work.

**COLUMBUS, O.**—The Buckeye Park Street Railway Company applies for a franchise to county commissioners. The incorporators are: Messrs' James H. Anderson, C. B. Cowan, DeWitt C. Jones, T. J. Keating, Geo. L. Converse, R. R. Dubois and Wm. H. Simonton. The capital stock is \$100,000, divided into shares of \$100 each.

**UPPER SANDUSKY, O.**—The Sandusky Valley Electric Railway Company is chartered. The projected line is to begin at Marion, Marion county, running to Upper Sandusky, Wyandot county; Tiffin, in Seneca county; Fremont, in Sandusky county, to Port Clinton, Ottawa county. The incorporators are John Q. Werick, R. R. Dumm, Frank E. Dumm, Gottlieb H. Roppold and Thomas Carroll.

**TOLEDO, O.**—N. B. Ream, of Chicago, and Parks Foster, of Elyria, O., have entered a combination. The belt line between Maumee and Toledo has been subdivided, Ream getting  $7\frac{1}{2}$  and Foster  $13\frac{1}{2}$  of the 21 miles of track. The belt is to be completed by August 1. The Foster line, called the Toledo & Maumee, has purchased the remains of the Tillotson material to use in the line. Bert Foster is appointed general manager of the new line. The Consolidated (Ream's line) is to furnish power at a stipulated price. Cars have been bought.

**TIFFIN, O.**—Three street railways of Tiffin embraced in the Tiffin Consolidated and the Interurban Consolidated have gone into the hands of Mesheck Frost, as receiver. The assets are \$150,000 and the liabilities will likely exceed that figure. The appointment of a receiver was made by Judge Norris, in the suit of the Cambria Iron Company, to secure a claim of \$5,000, but this was merely a form, as the Consolidated, since it failed to float its \$300,000 of bonds in New York City, is hopelessly involved, and the only way out of the difficulty is the sale of all their roads.

### Pennsylvania.

**MIDDLETOWN, PA.**—The East Harrisburg Railway Company has gained right of way between Highspire and Middletown.

**LANCASTER, PA.**—Members of the Hubley Manufacturing Company of Lancaster, Pa., have the contract for the Lancaster & Lilitz line.

**EDINBURGH, PA.**—C. S. Curtice, of Portland, N. Y., and other capitalists are working toward the new line between Edinburg and Erie.

**PITTSBURG, PA.**—The Interurban Rapid Transit Company has offices at 101 Fifth avenue and \$1,000,000 capital stock to exploit the Barrows Elevated Railway.

**PHILADELPHIA, PA.**—Plans for power house of the Nestonville, Mantua & Fairmount Passenger Railway are approved, and contract awarded to Charles McCaul, of 10 North Eleventh street.

**JENKINTON, PA.**—The Philadelphia, Cheltenham & Willow Grove Electric Railway Company has awarded contracts for its line from Rising Sun to Jenkinton, to William Wharton, Jr., of Philadelphia.

**POTTSVILLE, PA.**—The new officers of the Schuylkill Electric Railway Company are: President, C. H. Barret; treasurer, W. A. Barret, both of the Car Equipment Company, Philadelphia. J. B. Stuart is superintendent.

**PHILLIPSBURG, PA.**—Chas. A. Bragg, of Philadelphia, incorporates the Clearfield Traction Company, of this place. Directors are A. Markle, Henry Dryfuss, Hazleton; John G. Platt, Phillipsburg; George R. Bedford, Wilkesbarre; C. A. Bragg, Philadelphia.

**SCRANTON, PA.**—Scranton & North End Street Railway is granted a charter. Those interested are: L. Ammerman, Lieut. Governor L. A. Watres, H. H. Archer, P. S. Page and R. C. Adams. Eight miles will be built and cars will be run by November 1. It will connect several towns.

**PITTSBURG, PA.**—The Pitcairn, Wilmerding & Braddock Street Railway is capitalized at \$21,000 to build 3½ miles in the points named. W. J. Kline, of Greensburg, is president; the directors are W. J. Kline and Amos B. Kline, Greensburg; John S. Stewart, N. Versailles township; George W. Borrichlow, George C. Garber and H. L. Castle, Pittsburg.

**PITTSBURG, PA.**—The Homestead Street Railway Company has awarded contract for the building of the line to the New York Electrical Construction & Engineering Company. The officers of the railway are: J. C. Whitta, of Beaver Falls, president; J. B. Stone, Esq., secretary; C. H. Bentel, treasurer; C. A. Danals, general manager and superintendent

## Rhode Island.

**PAWTUCKET, R. I.**—The City Council orders fenders for the street railway, and attach a penalty for non-use.

**WOONSOCKET, R. I.**—The Woonsocket Street Railway voluntarily advances wages, restoring a cut to old tariff. New lines are planned for the near future.

## Tennessee.

**NASHVILLE, TENN.**—The Nashville Street Railway files deed by which it acquires the Maplewood Suburban Street Railway Company.

**WINCHESTER, TENN.**—Dr. B. G. Slaughter says that the contract for the Winchester Point Rock & Tennessee River electric railway has been let by J. Luttrell Murphy, Monadnock Building, Chicago, to Braeey Bro, McNair & Co., Monadnock Building, Chicago.

**CHATTANOOGA, TENN.**—Ex-President W. T. Adams, of the Chattanooga Electric Railway Company, has been relieved of his bond and Samuel Divine, appointed by Judge Key last week as permanent receiver of the company, will take charge of the lines. Mr. Adams will return to his former home at Corinth, Miss., and reassume charge of his property, the W. T. Adams Machine Company.

## Texas.

**BEAUMONT, TEX.**—The street railway was sold at public out cry to Albert Seal for \$400.

**SAN ANTONIO, TEX.**—Organized: The Manufacturers' Transportation Company, of San Antonio, for the purpose of constructing and operating a street railway for the transportation of freight. Capital stock, \$50,000. Incorporators—Charles Hugo, Philipp Carl, Geo Kalteyer and others.

**DALLAS, TEX.**—John Gill and W. H. Blackford, of Baltimore, Md., decide to ask the Farmers' Loan & Trust Company, of New York, to apply for a receiver for the Dallas Street Railway Company.

## Utah.

**SALT LAKE CITY, UTAH.**—The Salt Lake City Railway Company will extend to Calder's Park.

**SALT LAKE CITY, UTAH.**—Special order of the county court extends the franchises of the Rapid Transit Company fifty years, from January 1, 1894.

## Virginia.

**DANVILLE, VA.**—The Danville Street Railway Company will extend its tracks to Neapolis, across the Dan River.

## Washington.

**TACOMA, WASH.**—A "district organizer" of the Association of Street Railway Employes of America is trying to effect a branch of the union here.

**SEATTLE, WASH.**—M. F. Backus, receiver of the Ranier Power & Electric Railway Company, reports for the six months ending June 30, 1894: Net loss, railway department, \$4,056; gross earnings, \$3,819.

**SEATTLE, WASH.**—Fred E. Sander brings suit against the Seattle City Railway Company and A. G. Haas, receiver, to compel the honoring of a life pass for himself and family. The judge decides that the passes are valid.

## West Virginia.

**WHEELING, W. VA.**—Wm. Erskine has resigned the presidency of the Wheeling Railway Company, being succeeded by A. B. Champion.

**WHEELING, W. VA.**—A. M. Jolly has resigned his position as general manager of the Wheeling street railway, and W. S. Wright, who had accepted the position as mechanical engineer at the company's barns has been appointed to fill the vacancy.

## Wisconsin.

**FOND DU LAC, WIS.**—The Fond du Lac Light, Power & Railway Company has shut down its street railway business and discharged all employes. President DeCelle says lack of patronage is the cause. The equipment will be sold.

**MADISON, WIS.**—Judge Siebecker has appointed Col. Webster H. Moore, of Beloit, receiver of the Madison Street Railway Company, on the application of the Four Lakes Light & Power Company, which was furnishing power for the line.

**RACINE, WIS.**—C. H. Holmes, president and treasurer of the Belle City Street Railway Company, has transferred all of his interest in the road to Jackson I. Case, and Mr. Case in turn transferred all of his interest in the Green Bay (Wis.) Electric Road to Mr. Holmes. The latter gentleman will go to Green Bay and manage the road. The value of the Racine road is \$250,000, and the Green Bay road \$150,000.

## Custer's Last Battlefield.

A visit to this spot, which is now a National Cemetery, is extremely interesting. Here, seventeen years ago, General Custer and five companies of the Seventh U. S. Cavalry, numbering over 200 officers and men, were cut to pieces by the Sioux Indians and allied tribes under Sitting Bull. The battlefield, the valley of the Little Big Horn, located some forty odd miles south of Custer, Montana, a station reached by stage. If you will write Chas F. Fee, St. Paul, Minnesota, inclosing four cents in postage, he will send you a handsomely illustrated 100 page book, free of charge, in which you will find a graphic account of the sad catastrophe which overtook the brave Custer and his followers in the valley of the Little Big Horn, in June, '76.



## STREET RAILWAY PATENTS.

ISSUED JULY 3, 1894.

Electric railway car truck. Francis O. Blackwell, assignor to the Thomson-Houston Electric Company, of Connecticut.....	522,189
Wire support for overhead electric railways. Arthur W. Jones, Boston, Mass., assignor to the Thomson-Houston Electric Company, of Connecticut.....	522,216
Trolley car. Herbert J. Lycett, Bryn Mawr, assignor to John A. Brill, Philadelphia, Pa.....	522,224
Rail joint and bond for electric railways. Julius Meyer, New York, N. Y.....	522,349
Suspension clip for trolley wires. William F. D. Crane, East Orange, N. J., assignor to the Johns Pratt Company, Hartford, Conn.....	522,362
Electric railway supply circuit. Rudolph M. Hunter, Philadelphia, Pa., assignor to the Thomson-Houston Electric Company, Conn.....	522,374
Electric railway switch and trolley. Frederick S. Perrin, Lynn, Mass., assignor of three-fourths to William B. Baldwin, New York, George Fink, Jersey City, N. J., and Anthony F. Buchenberger, Brooklyn, N. Y.....	522,388
Conduit electric railway. John H. Tyrrell, New York, N. Y.....	522,440
Electric railway conduit. Albert T. Fay, Minneapolis, Minn.....	522,460
Conduit for trolley arms. Albert T. Fay, Minneapolis, Minn.....	522,461
Electric automatic circuit breaker. Carl W. Larson, Lynn, assignor one half to August Langell, Boston, Mass.....	522,527
Car fender and brake. Henry Maass, Jersey City, N. J.....	522,530
Trolley wheel. Charles E. Bostwick, Du Bois, Pa., assignor one half to G. E. Grier, James W. Grier, and John C. Grier, same place.....	522,550

ISSUED JULY 10, 1894.

Gear casing for railway motors. Norman C. Bassett, Lynn, Mass., assignor to the Thomson-Houston Electric Company of Connecticut.....	522,579
Controller for electric motors. John B. Blood, Lynn, assignor to the General Electric Company, Boston, Mass.....	522,581
Roller bearing. Frank S. Church, Detroit, Mich., assignor one-half to W. Fitz Hugh Edwards, same place.....	522,648
Conduit railway trolley. John L. Creveling, Auburn, N. Y.....	522,655
Contact shoe for electric locomotives. John J. Green, Boonton, N. J., assignor to the Universal Electric Company, New York, N. Y.....	522,709
Contact bar for electric locomotives. John J. Green, Boonton, N. J., assignor to the Universal Electric Company, of the City of New York.....	522,710
Supply system for electric locomotives. John J. Green, Boonton, N. J., assignor to the Conduit Construction Company, of New York, N. Y.....	522,711
Cable railway. Charles W. Hunt, West New Brighton, N. Y.....	522,713
Trolley car. Charles A. Lieb, New York, N. Y., assignor to the General Electric Company, Boston, Mass.....	522,844
Trolley wheel. Charles A. Lieb, New York, N. Y., assignor to the General Electric Company, Boston, Mass.....	522,845
Closed conduit for electric railways. Charles I. Greer, Washington, D. C., assignor one-half to Charles B. Peirce, same place.....	522,894
Track cleaner and switch thrower. Isaac W. Hewitt, Akron, O.....	522,898
Car fender. Lucius Q. C. Lamar, Oxford, Miss.....	522,905
Street railway switch. William E. Murray, Daniel W. Hatfield and George W. Hatfield, Harrisburg, Pa.....	522,914
Trolley pole. Alexander S. McBean, Montreal, Canada.....	522,915
Anti-oscillating attachment for street cars. Benjamin F. Chollar, Ft. Worth, Tex., assignor of one-half to Geo. B. Hendricks, same place.....	522,929

ISSUED JULY 17, 1894.

Electric railway supply system. William A. Butler, New York, N. Y., assignor to John Gilmore Boyd, same place.....	523,104
Conduit electric railway. Charles D. Jenny, Indianapolis, Ind.....	523,146
Switch point for street railways. Herbert S. Smith, Brooklyn, assignor to himself and Frank E. Knight, New York, N. Y.....	523,154
Trolley. Joseph Guzowski, Chicago, Ill.....	523,163

Supply system for electric railways. Edward H. Johnson, New York and Robert Lundell, Brooklyn, assignors to the Johnson Subtrolley Company, New York, N. Y.....	523,164
Supply system for electric railways. Edward H. Johnson, New York, and Robert Lundell, Brooklyn, assignors to the Johnson Subtrolley Company, New York, N. Y.....	523,165
Supply system for electric railways. Edward H. Johnson, New York, and Robert Lundell, Brooklyn, assignors to the Johnson Subtrolley Company, New York, N. Y.....	523,166
Electric railway crossing insulator. Henry B. Nichols and Frederick Lincoln, Philadelphia, Pa.....	523,172
Guard rail for street railways. Gleason F. Starkweather, Chicago, Ill., assignor to the Paige Iron Works, same place.....	523,182
Conduit electric railway. John W. Eisenhuth, San Francisco, Cal.....	523,271
Electric rail bond. James G. Hallas, Waterbury, Conn., assignor to the Benedict & Burnham Manufacturing Company, same place.....	523,278
Bonding joint for electric railways. Andrew L. Johnson, Richmond, Va.....	523,284
Electric railway. Henry A. Doty, Janesville, Wis., assignor to Mary E. Doty, same place.....	523,306
Electric railway system. Rudolph M. Hunter, Philadelphia, Pa., assignor to the Thomson-Houston Electric Company, of Boston, Mass.....	523,313
Electrical conductor for trolleys. John W. Eisenhuth, San Francisco, Cal.....	523,319

ISSUED JULY 24, 1894.

Electric railway system. Albert C. Crehore, Ithaca, N. Y.....	523,396
Electric snow plow. Louis J. Hirt, Somerville, Mass.....	523,471
Street car guard. Charles A. Barrett, Malden, Mass.....	523,507
Car fender. Franklin S. Hogg, New York, N. Y., assignor to himself and Barton B. Higgins, same place.....	523,526
Track cleaner. Oscar Rothrock, New York, N. Y.....	523,595
Trolley catcher. Edwin M. Drummond, Louisville, Ky., assignor one-half to Joseph O. Haddox, same place.....	523,625
Grip slot closer. Frederick W. Gremmels, Kansas City, Mo., assignor one-half to Andrew Hamilton, same place.....	523,636

ISSUED JULY 31, 1894.

Life guard for street cars. George A. Parmenter, Cambridge, and Charles S. Gooding, Brookline, Mass., assignors to the Parmenter Car Fender Company, of Maine.....	523,683
Car fender. Edgar Thomas, Pittsburg, assignor of one half to Philip M. Amberg, Allegheny, Pa.....	523,693
Car brake. John T. Duff, Pittsburg, Pa.....	523,763
Guard for street railways. William T. Vose, Newton, Mass.....	523,921

## DIED IN A GOOD CAUSE.

MRS. EINSTEIN. "Mein Gott, Isaak, Mein Gott, poor little Abraham was kilt."

ISAAC. "Himmel, Rachel, how was dot happens, mine poor boy?"

MRS. E. "On dose electric cars, Isaak."

MR. E. (joyfully). "Gott pless dat poy, he always did have a goot head, he knew his poor fader could collect damages."

THEY met in a Madison avenue car, and when she entered he closed the serious looking legal volume with which he had been beguiling the tedious ride uptown, so that the title was visible—somebody's "New York Digest." After a few casual remarks the young woman's eye lighted upon this legend on the back of the calf-bound volume. "Why," she said in surprise, "I didn't know you were studying medicine. I thought you were reading law!"

**GENERAL ELECTRIC GENERATOR PANEL.**

The General Electric Company has made some important changes recently on its switchboard apparatus. The new feeder panel was shown in these columns some time ago, and the accompanying engraving is of the new generator switchboard panel. A radical change over the old style is the doing away with three-pole switches. The general principle of the connection of the new panel can be seen in the accompanying diagram. The main positive and negative switches and the field switch are on the switchboard panel, while the equalizer switch

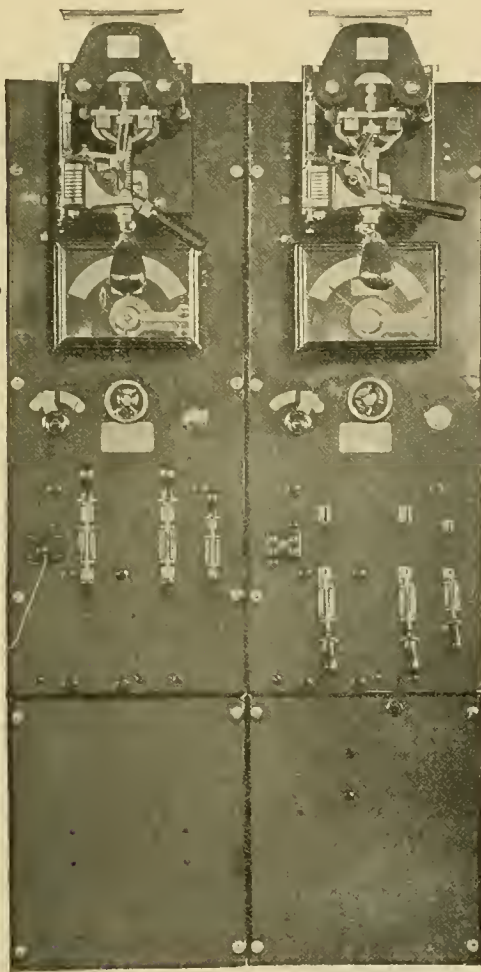

is on the machine. Thus the necessity of running the equalizer to the switchboard is avoided. In throwing in a generator the equalizer and main positive switches are first closed. This connects the series coil of the new generator in parallel with the series coils of all the other machines connected to the bus bars. The shunt field switch is then closed and the voltage brought up until it is the same as that on the bus bars. The negative switch is then closed, thereby throwing the generator in. One of the great advantages of this method is that the series field windings are thrown into action before the machine is connected in. Consequently the voltage of the machine before it is thrown in will vary as does the voltage of the main bus bars. This is a decided help to

the operator, especially if the voltage on the bus bars varies rapidly. These panels are wired up at the factory, so that they are easily installed at the station. All the panels made by this company are of a uniform height. In addition to the main and field switches, the panel contains a double-pole voltmeter plug, a lighting switch, an ammeter, circuit breaker and lightning arrester. The circuit breaker has a main contact in shunt with a smaller contact working within a magnetic blow-out. The main

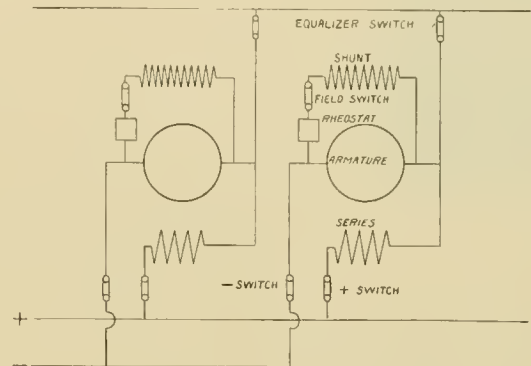

WIRING SCHEME OF PANEL.

contact is opened first. The lightning arrester has two carbon points (one of which is grounded) in the field of an iron clad electro-magnet.

The new panels are known as type "K," and are made in capacities of from 200 to 3,000 amperes.

**CHICAGO GENERAL STREET RAILWAY COMPANY PRIZES.**

In May, the Chicago General Street Railway Company, through the STREET RAILWAY REVIEW, invited drawings and specifications of a model plant for the use of forty cars, giving dimensions of the prospective site on which the buildings would be placed, and offered a first prize of \$100; second prize, \$75; third prize, \$50, and fourth prize, \$25. The selection was recently made by which the first prize was awarded to J. R. Cravath, electrical editor of the STREET RAILWAY REVIEW; second prize to Caywood & Ritter, contracting engineers, Chicago; third prize to A. S. Krotz, engineer, Springfield, O.; fourth prize to E. W. Goss, superintendent of the Amesbury Electric Light, Heat and Power Company, Amesbury, Mass.

None of the plans selected will be used in full, but ideas will be adopted from each. The site selected for the new power plant is a four-acre lot, corner of Kedzie avenue and Thirty-first street. It is expected that a car-shed 125 by 300, engine room 100 by 100, and boiler room 100 by 60, will be constructed this fall, the other buildings to follow as rapidly as the work will permit. The operation of the present lines will be under the management of the president, L. McGann, and the superintendent, W. F. Brennan, while C. L. Bonney, vice-president, will have charge of the constructing of the new lines and power plant.

## THE ELLIS MANUFACTURING COMPANY.

Within the past two months there has arisen a new star in the street railway firmament which shines for all, but particularly for the buyers of electric car trucks. The home of the Ellis Manufacturing Company is at No.



HARVEY ELLIS.

218 South Fourth street, Philadelphia, and its officers are, Harvey Ellis, president, and Joel C. Hancock, secretary and treasurer. The product to be handled is the Hansell equalizing motor truck, an engraving of which is shown herewith. The prominent and novel feature of the Hansell truck is the equalizing beam outside the journals, supporting an elliptic and spiral spring. It is the in-

tent of this construction to obtain the full benefit of both springs, as well as to take up whatever oscillation there may be. The makers of the truck claim, however, that they prevent the cause of oscillation, as nearly as is possible, by cushioning the journals with two strong spiral

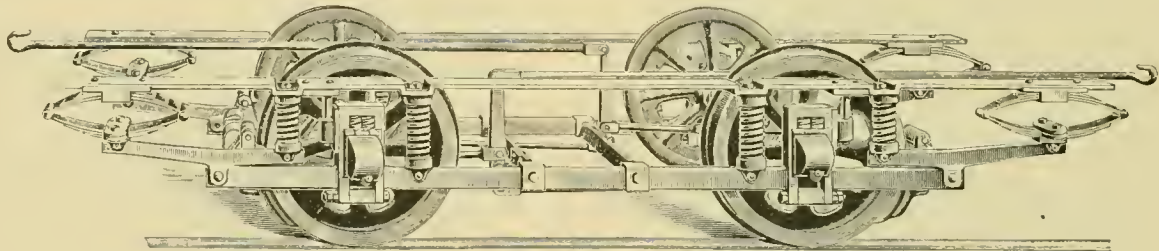

THE HANSELL TRUCK.

springs over each journal box. The spring base is proportioned and constructed on the cantilever principle, with a view of distributing throughout the entire car body and truck the load at any one point.

The truck frame is strongly constructed and composed of but few parts, with these few easily accessible. The spring base may be adapted to any length of car body by simply lengthening the equalizing beam and stiffening the spiral springs on the inner ends of the beams. In this lies their claim that the Hansell truck has the longest spring base of any truck on the market. The truck is composed entirely of steel, with no rivets and as few bolts as possible. This arrangement, of course, contributes to the strength and inflexibility of the truck structure. To recapitulate the claims, they are: Freedom from oscillation; elimination of the cause of oscillation; few parts and easily accessible; economy of maintenance; strength and durability of truck frame.

As to the accessories, there is a powerful brake of great leverage capacity, with positive and simultaneous action on all brake shoes. The wheels and axles are easily and quickly removable by taking out one bolt under each journal. The journal boxes are of the M.

C. B. pattern, which has had so long and satisfactory service, dust proof, and adapted for oil or grease.

Another feature is the separation of the plunger bolt from the inside of the spiral spring. This permits of repairs to either, with least possible loss of time, the journal yoke being broad and giving broad guide surfaces to the journal box. Taking all in all, the Ellis Company has a reliable truck, for which it does not claim cheapness as a chief charm, but rather good material and good workmanship, with the intent of supplying satisfactory service to its patrons.

A word as to the personnel of the company will not be out of place at this point and we take pleasure in introducing the two chief officers.

Harvey Ellis, the president of the company, is well known to the majority of street railway men in his 18 years' connection with the Cambria Iron Company. Mr. Ellis has occupied various responsible positions with the Cambria, both at the works and in the Philadelphia offices, and latterly was assistant treasurer. He is a gentleman of more than ordinary business worth and executive talent.

Joel C. Hancock, the secretary and treasurer of the Ellis Company, is another old Cambria man of many

years' standing. Prior to this connection he was with the Pennsylvania Railroad Company, where he has had a complete and valuable experience in railroad work. His genial personality and thorough knowledge of details makes him an efficient business man as well as a desirable acquaintance.



JOEL C. HANCOCK.

The Pittsburg and southern sales agents of the Ellis Company are S. P. S. Ellis and Mr. Minnegrode, two familiar names of successful salesmen.

Both gentlemen are of the type of salesmen that not only are able to get a customer, but retain him afterwards.

At Bridgeport, Conn., July 26, a regular war was waged between the New York, New Haven & Hartford Street Railway Company and the Bridgeport Traction Company employes over a railroad crossing. Steam and water were the weapons, and 5,000 people watched the fun. Injunctions finally caused a cessation of hostilities.



THE Card Electric Company, of Mansfield, O., finds business very satisfactory.

HENRY ELLIOTT, of the Elliott Frog & Switch Company of St. Louis, has gone abroad on a five months' trip.

THE Westinghouse Electric and Manufacturing Company has sold the Hartford Street Railway Company forty car equipments.

THE R. A. Crawford Manufacturing Company, Pittsburg, has sent 50 additional fenders to the New Orleans, La., Traction Company.

THE American Car Company, of St. Louis, has recently taken an order for 25 cars from the Union Depot Railroad Company of St. Louis.

E. F. DEWITT & Co., of Lansinburgh, N. Y., number among late orders the equipment of 200 electric traction cars of Philadelphia with the common sense sand box.

JOSEPH T. SKERRITT has resigned the superintendency of the Brigantine Transit Company of Atlantic City, N. J. His address is now 226 Atlantic avenue, Atlantic City.

J. G. GUSTIN & Co., of Chicago, are busy as possible filling orders for the Hercules trolley clamp. Duplicate orders attest to the esteem in which street railway men hold this excellent device.

THE Adams Boiler Company, Cleveland, has just sold a 500 horse-power boiler to the Richmond Railway and Electric Company, of Richmond, Va., which will be shipped and installed at once.

THE McLean Armature Works, Chicago, report a first-class repair business in all departments. The company has lately added a department for the manufacture of electroliers and combination fixtures.

EDWARD CALDWELL has assumed a nominal editorship on the Street Railway Journal staff. J. W. Dickerson now takes full editorial charge of the Gazette branch of this enterprising publishing company.

THE Pettingill-Andrews Company of Boston has installed Frank X. Cicott as manager of its New York office, at 39-41 Cortlandt street. Mr. Cicott is manager of the railway department of the company as well.

JOHN CRILLY, 123 California street, San Francisco, reports the sale of a Peckham 6 D. truck to the Alameda, Oakland & Piedmont Electric Railway Company. Mr. Crilly is unusually successful this season in his business.

THE summer girl in her bathing dress,  
They say is a vision of loveliness,  
But it isn't the dress that makes the hit  
When she shows herself, but the lack of it.

—New York Press.

THE American Carbon Company, of Dayton, O., is experimenting with motor brushes and will soon put a superior carbon brush on the street railway market. Manager Dickey, of the company, is an eminently practical man.

THE Ball Engine Company reports a large number of engines as being shipped from the Ball works to fields of usefulness in the electric light and power line. Nearly 2,000 horse-power is the aggregate, ranging from 80 to 300 horse-power.

R. L. CALDWELL, formerly with the Short Electric Railway Company, is now with the Sperry Company and is at present looking after the interests of that concern on the Chicago General Street Railway, which is equipped with Sperry motors.

MANAGER J. S. SPEER, of the Partridge Carbon Company, Sandusky, O., reports the factory running at full time, with plenty of orders on hand. The carbon brushes still continue to give the best of results, and to spread their fame throughout the trade.

THE National Telephone Manufacturing Company, of Boston, has just received an order for 1,000 receiver and transmitter telephones for use in the new Hotel Majestic, New York City. This order speaks well for the efficiency and popularity of the National Telephone.

REGER & ATWATER, 214 Pine street, San Francisco, Cal., have taken the Pacific coast agency for A. O. Schoonmaker, 158 Williams street, New York, and will carry a full stock of his well-known mica, both cut and uncut and stamped for segments and rheostats. They can fill all coast orders with dispatch and accuracy.

THE Bemis Car Box Company of Springfield, Mass., among recent orders chronicle the following: 50 trucks for the Electric Traction Company, Philadelphia; 25 for the Hestonville, Mantua & Fairmount, Philadelphia; 30 for the Fairhaven & Westville Company, of New Haven, Conn.; 180 for the Third avenue cable of New York City.

J. M. DENNISTON having relinquished the R. D. Nuttall agency for Chicago and the Northwest, the company has appointed Garson Myers, of the Standard Railway Supply Company, to represent these well known specialties. Mr. Myers is too well known to the trade to require further mention, and the Nuttall specialties are worthy of his efforts.

THE Keithley rail bond is being put in by the North and the West Chicago Street Railroads. The Chicago City and the North Shore street railways have already adopted it, and the bond business booms a pace. Washburn & Moen, 107 Lake street, Chicago, are manufacturers and agents. Mr. Keithley is spending the summer on Staten Island.

LEE & COLLINS, Medinah Temple, Chicago, is the habitation and name of a new supply company carrying electric light and battery specialties. C. E. Lee, the senior partner, is a well-known salesman, and L. W. Collins is extensively acquainted with all branches of the trade as an electrical journalist of wide range and ability. We are sorry to lose him.

THE Railway Department of the Wallace Electric Company has been kept quite busy notwithstanding the dull times. The combination pole bracket, which affords a flexible support for the insulator, is meeting with a ready sale and with success. The various devices for overhead construction handled by the company are well received by superintendents.

J. A. WILLIAMS & Co., Utica, N. Y., and Chicago, have been appointed as one of the agents of the United States Headlight Company of Utica. The new agents will carry a full line of locomotive, electric, cable, motor car and other headlights in standard styles and sizes, from which assortment the purchaser may have his order filled with neatness and dispatch.

THE Ellis Manufacturing Company, of 218 South Fourth street, Philadelphia, which is so actively pushing the Hansell electric equalizing truck, advises us that it is negotiating with a number of representative commission men in the trade to act as local selling agents, and that it has not closed finally for all places and will be glad to enter into correspondence with desirable parties.

THE St. Louis Railway Company, of St. Louis, Mo., has placed an order with the Berlin Iron Bridge Company, of East Berlin, Conn., for its new car barn. The building will be 64 feet wide and 185 feet long, with brick walls and a roof of the Berlin Iron Bridge Company's patent anti-condensation corrugated iron. There will be no wood work in the building whatsoever.

THE Lewis & Fowler Manufacturing Company, of Brooklyn, N. Y., is doing its accustomed large business. The company reports gratifying sales of the Acme car jack and the Lewis & Fowler fare register. A recent car order was for five open cars for the South Jersey Street Railway Company of Point Pleasant, N. J. They are mounted on Peckham trucks and are driven by Westinghouse motors.

H. J. WIGHTMAN & Co. have removed their offices to the Schimpff building, 414 Spruce street, Scranton, Pa.

In their new quarters they have increased facilities and conveniences, and are prepared to execute all orders with promptness. The Wightman line of street railway material is a specialty in which they take much pride, and an invitation is extended every one to visit and inspect the stock.

DOVEY & COMPANY, of Philadelphia, the well known contractors, have been awarded the contract for completely rebuilding, electrically equipping, and extending the New Haven & Centerville Street Railway, New Haven, Conn. The manager of the company is John S. Dovey, and S. A. Coleman is the engineer. The road is to use 70-pound rail, and is to be completed within three months. Power will be rented at present.

THREE of the largest leather belts in the Dominion were ordered some time ago by the Montreal, Ont., Street Railway Company, for its new power house on William street. The order was placed with the J. C. McLaren Belting Company. One of the belts is already set and the second has been exhibited through the streets. The third is in course of construction. They are one hundred and forty feet long and fifty-four inches wide and are made of three-ply English oak-tanned leather. Each belt weighs 2,150 pounds.

W. R. GARTON, the bright electrician and well-known inventor of the Garton lightning arrester, has accepted the management of the recently organized railway department of the Central Electric Company, Chicago. Mr. Garton's peculiar fitness for the position is acknowledged both by his business ability and his electrical knowledge, not saying anything of his being a pleasant gentleman and a hustler. Mr. Garton retains his interest in the well-known arrester to which his name is given, but his duties with the Central will consume all his activities.



W. R. GARTON.

THE Mather Electric Company, of Manchester, Conn., reports signs of improvement in its electrical business, now having on hand more work than at any other time for the last eighteen months. The recent sales of its standard belted, and also of its new direct connected apparatus for lighting work, have been very large, necessitating a large addition to the working force in the works at Manchester. It also reports a very good business throughout the western and central states, in which territory J. Holt Gates, of 1140 Monadnock Building, Chicago, is the well-known representative.

THE well known cedar-pole firm, W. C. Sterling & Son, of Monroe, Mich., has just received at their yards at Monroe, a large raft of cedar poles from the north, and expect two more during the summer. One crib in the next raft will be over 400 feet long, the longest that has ever come down the lakes, and contain about 6,000



poles. The Monroe yard is one of the largest in the world, and is well known all over the country. From this yard shipments are made to all points in the United States, and all material in the line of cedar that is used in the construction of electric light, railway, telegraph or telephone lines is manufactured and furnished.

EDWARD F. AUSTIN, the Pittsburg representative of the W. A. Green automatic cut-off engine, manufactured by the Altoona Manufacturing Company, of Altoona, Pa., reports a flourishing business. The following recent instalments of the Green engines are noted: 50-horse-power to drive a 500-light Westinghouse dynamo in Christ's M. E. Church, Pittsburg; 80-horse-power engine at the New Castle, Pa., Car Manufacturing Company's plant; one 150-horse-power to run the electric cranes at Jones & Laughlins' works, Pittsburg; 150-horse-power in Watson Mining & Manufacturing Company's plant, at Monongahela City, Pa., and several smaller machines in office buildings of Pittsburg. Mr. Austin's untiring efforts have resulted in great popularity of the excellent Green engine in this part of Pennsylvania.

HENRY P. MERRIAM, master mechanic of the Albany, N. Y., Railway Company, writes of the New Process Rawhide Company's rawhide pinions as follows:

"Regarding the two rawhide pinions sent us on trial, I can say that they were put on a car running on State street hill soon after your last call at Albany, and have been running every day since. I have examined them frequently, and they appear to be good for some time longer. The cast iron gears put on at the same time are as good as new. The result has been a great surprise to me. The bill for the two pinions has been approved and entered for payment."

The hill mentioned is a very steep and difficult grade, and the good words for the New Process pinion should rejoice the heart of President Meacham and his confreres.

FISHER & PORTER, 1025 Monadnock block, report the installation of two 80-horse-power M. A. Green engines in the Leland Hotel, where they are running two National dynamos for incandescent lighting. They have sold one 150-horse-power M. A. Green engine to the Freeport Electric Company, of Freeport, Ill., for electric street railway work, and one 300-horse-power Improved Green engine to the Hammond, Whiting & East Chicago Electric Railroad Company, at East Chicago, Ind. Messrs. Fisher & Porter are western representatives of the Altoona Manufacturing Company, building the M. A. Green engine, and of the Providence Steam Engine Company, building the "Improved Green" engine, and say that the works of both companies are running full time, and that they see prospects ahead for a good business.

CLARENCE P. KLINE, late superintendent of the Kansas City, Kan., division of the Metropolitan cable line, has been made superintendent of the Kansas City, Mo., elevated. Mr. Kline has been in the employ of the Metropolitan company for six years. He began as a

gripman on one of the company's cars, and afterward became superintendent of the Twelfth street line, which position he held for three years, afterward taking charge of the Kansas City, Kan., division. He is only 27 years of age. He was born in Scioto, McDonough county, Ill., and has been in the Kansas Cities about ten years. The position made vacant by the promotion of Mr. Kline will be filled by J. F. Voris, who is at present assistant superintendent of the Kansas City, Kan., division of the Metropolitan cable line. He has been with the company several years.

ROBINSON & TROUTMAN, of 1309 Chamber of Commerce building, Chicago, are now western agents for the Buckeye engine, of Salem, Ohio. H. E. Troutman, who



H. E. TROUTMAN.

comes to the western office from Pittsburg, is a thorough engineer, and a most affable gentleman. The first fruits of the new arrangement since June, are: 150-horse-power, to the City Electric Light & Power Company, Danville; 300-horse-power, to the Danville Gas, Electric Light & Street Railway Company, Danville, Ill.; 100-horse-power complete plant to the town of Goodland, Ind. H. E. Troutman, the younger of the representatives, is a Pittsburger of long standing and an engine man of ten years' experience. He is young in years, but old in experience, having passed eight years with the Taylor Engine Company before his present connection with the Buckeye.

THE Bass Foundry & Machine Company, of Ft. Wayne, Indiana, has been doing a magnificent business of late. For the New Castle, Pa., Wire Nail Company, the Bass engineers have just installed a tandem, compound, condensing Corliss engine, with high pressure cylinder of 36 inches diameter, low pressure 70 inches and stroke 60 inches. The driving pulley is 25 feet in diameter, 9-foot face and grooved for 32 two-inch ropes. The engine is rated at 2,000 horse-power. It is a magnificent piece of mechanism and the company says it is probably the largest tandem engine ever built in this country. The Bass Company has a national fame for large work and this last performance keeps up its reputation. Salesman P. F. Leech, of the Bass Company's wheel department, reports a flourishing business both in cushion and cast iron wheels. The Ft. Wayne, Chicago and St. Louis concerns have plenty to do. Recent orders from electric railways are: 100 (steel) for the Electric Traction Company, Philadelphia; 180 (cast iron) wheels for a well-known car builder; 1,200 for the New Orleans, La., City & Lake Railway; 380 for the Cincinnati Consolidated; 100 to the Toledo Consolidated; 100 to the Akron & Zanesville Railway, and a large number of smaller orders. The Bass Company is about to establish another factory at Lenore, Tenn., to supply the southern and southwestern territory.

## A QUEER CROSSING.

One of the most remarkable temporary crossings ever used by street railway lines is now in existence at the intersection of Blue Island avenue and Twenty-second street, Chicago. The Blue Island avenue cable has been laid for some time and last spring the electric line of the Chicago General Street Railway was built on Twenty-second street, but owing to the usual crossing troubles between rival corporations no crossing was laid, and the electric line was obliged to make a transfer across the cable tracks. One night, Superintendent Brennan, of the electric line, had occasion to run some cars over the crossing on the pavement, as this was the only way to get cars from one division of the road to the other. Contrary to expectations, it was found that the cars did not cant or slew around on striking the cable rail, but went over the cable tracks in very nearly a straight course. The angle of crossing is approximately 60 degrees. The

cable road is on a curve of very long radius. The straight course kept by the cars when nothing was present to prevent slewing encouraged Mr. Brennan to put in the temporary crossing, of which a plan drawing is here shown. It has been in service for over two months, with cars

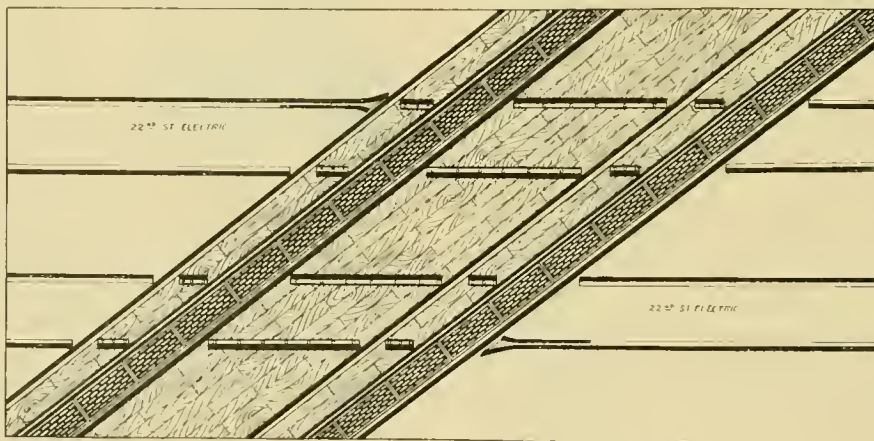

"A queer crossing."

crossing it every five minutes and oftener. In that time not a car has run off the track at this crossing. This record seems nothing short of marvelous, considering how good the chances seem to be for a derailment. When the crossing was being put down several people thought that Mr. Brennan's mind was affected, but they have all disappeared since. In laying the crossing, planks were substituted for the paving between and near the cable tracks, and on these planks were spiked the replacing frogs and short sections of tram rail shown in the sketch. On account of the curve on the cable road, man-hole plates cover one-half of the space between the cable rails. Across these plates the cars of the electric line run on their flanges. At first the cars would get somewhat out of line and be brought back by the replacing frogs, but now the flanges have cut grooves so that the replacing frogs are hardly necessary.

A STUPENDOUS scheme to connect England and France by an electric railway is suggested by Sir Edward Reed, an English engineer. He would build a metallic channel on the sea bottom. The cost is estimated at \$75,000,000 and it will require five years to build.

## CHICAGO LAKE STREET "L" ELECTION.

The Lake street elevated railway, under the management of the new owners, elects the following directors: B. E. Sunny, of the General Electric Company; A. P. Richardson, of New York; Solomon Sturges, Jr., of the Northwestern National Bank, Chicago; A. S. Littlefield, of the American Railway Construction Company, and D. H. Louderback. The four old directors who did not resign are John A. Roche, John H. Witbeck, Clarence A. Knight and William Zeigler.

## UTICA BELT LINE REORGANIZES.

After a number of unsuccessful attempts, the Utica Belt Line has effected a reorganization. By order of court, the bondholders having previously agreed to the proposition, a meeting was called, at which 1,500 shares of stock were represented. A board of directors was

elected, which in turn chose the following officers: President, John W. Boyle; vice-president, James T. Gardiner; treasurer, Charles W. Mather; secretary, Edward Bushinger; executive committee, John W. Boyle, Charles W. Mather, James T. Gardiner.

The receiver has been discharged and the new management entered upon its work. Money will be expended to bring the line to proper condition for economical operation.

## COMMONWEALERS AS AN ATTRACTION.

Here is an idea for other enterprising managers. The commonweal army of tramps, under "General" Jeffries, recently reached Bay City, Mich., and after being break-fasted promised to proceed, but the enterprising management of the Bay Cities Consolidated Street Railway Company evolved the brilliant idea of taking the whole array to Wenona Beach over Sunday. So in the afternoon the 'wealers were loaded on to seven cars and with a brass band accompaniment were taken to the resort. The next day, Sunday, everybody in the Bay Cities went to see the sight and many shekels went into the company's coffers; but the citizens were angry all the same, although the authorities protested all they could.

THE Allgemeine Elektrizitäts Gesellschaft has acquired the Bucher concession for electric tramways at Genoa, for \$240,000. Part of the line is already built.

THE THREE WIRE TROLLEY SYSTEM  
AT BANGOR, ME.

By J. G. Carroll, Superintendent Bangor Public Works Company.

Having noticed an article in one of the electrical journals suggesting the feasibility of operating an electric railway by the three wire system, I became much interested, particularly as the road I am connected with has been using that method for some three years. The article stated that such method was possible or practicable only on double track road. I will endeavor to make clear how it is possible to operate a single track road by such methods. In the first place our power plant being situated  $4\frac{1}{2}$  miles from the nearest point of the road, it was necessary that some means be devised to avoid the enormous expense that would be incurred in getting the copper wire necessary to have a metallic circuit. We tried in the first place to get a ground return by putting copper ground plates in the river at different points along our route and at the power station, but to no purpose. A portion of our line  $2\frac{1}{2}$  miles long situated in the city of Brewer is connected at each hydrant with the rail, and as we operate the water system of that city, and the pumping station is in the same building as the railway power plant, this gives us a good return when needed. But operating as we do now by the three wire system, this is unnecessary when in balance. We have 7.74 miles of single track with seven turnouts. The rail is 35-pound, one-half tram and the balance T. The system consists of two distinct roads, one in the city of Brewer about  $2\frac{1}{2}$  miles long and the other in Bangor,  $5\frac{1}{4}$  miles. By reference to the map it will be seen that there is no connection between the two. The rails are

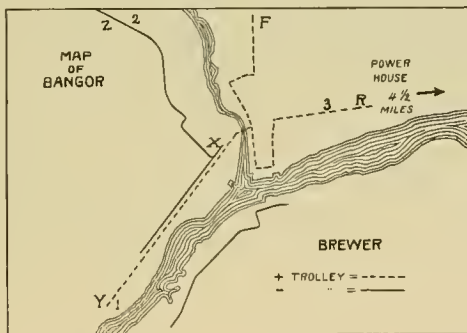

bonded at the joints with No. 4 copper bonds and connected at each joint with a supplementary No. 4 copper wire.

Our power plant consists of four Thomson-Houston generators, driven by four Holmes turbine wheels of 120 horse-power each. Our equipment consists of two F-30 motors under each car. We operate in regular service nine motor cars, and nearly every week day run three additional motor cars, drawing three trail cars. We connect our generators as in Fig. 1, each two machines being connected in multiple. For convenience we will call two machines on one side A and the other two B.

The positive side of group A is connected to earth and the negative of B to earth; the positive of B to line and the negative of A to line. From B is run a main composed of five No. 0 wires and from A is run a main of four No. 0 wires. The mains terminate at a point near the center of the city and three feeders are run from B to different points along the positive trolley wire, while two feeders are run from A to the two sections of negative trolley wire indicated by the map. It will be seen that there are two trolley wires from X to Y. From one of these a branch runs to Z. The wires from X to Y are of different polarity, and of course carefully insulated

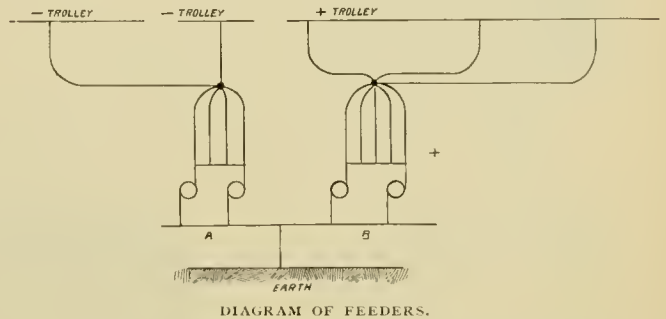

from each other. The use of two wires does away with the use of overhead frogs at turnouts and serves another important purpose in the balancing of the system, which will be explained later.

In order to operate successfully the load on each side must be equal or nearly so. This we accomplish in the following manner: Our time table and turnouts are so arranged as to admit of a 15 minute schedule. Every 15 minutes four cars are at X and at the same time three are at the ends of the routes 1, 2 and 3. This applies to the Bangor divisions. At the same time two cars are at the ends of the line on the Brewer division. In operation one car bound from X to Z takes the negative wire. One car bound from X to Y takes the positive wire. One car is bound from X to F and one from X to R on the positive side. This arrangement gives us five cars on the positive side and four on the negative. As long as this balance is maintained, everything runs smoothly. In putting on extra cars we have occasion to run them only from Y, which is a point opposite the fair grounds to X, which is the business center of the city. By making these extra cars, use alternate wires; this balance is still maintained. We have a number of heavy grades and short curves. In fact, there is scarcely a level piece of track in Bangor. For instance, on the Pearl street line we have a grade of 6 per cent for 200 feet; on Main street one of 8 per cent for 100 feet; on Olive street one of seven per cent and two of 5 per cent; on Center street one of 8 per cent for 200 feet; and in Brewer four of 6 per cent, one of which is 500 feet long.

The one bad feature of this system is that in case of a generator getting disabled we are out of balance by having two machines on one side and one on the other. This we intend to remedy by having a spare generator ready to put in on either side, as may be necessary.

## THE MATHER GENERATORS.

The Mather Electric Company, of Manchester, Conn., has been giving special attention to large railway generators since its re-organization, and now has a type which differs somewhat in appearance from the majority of multipolar railway machines, but which is thoroughly efficient and reliable. The fields are in four pieces, which are bolted together and are entirely separate from the frame. This makes the taking apart and putting together of a generator very easy. They give nominally 500 volts, but can be raised to 600.

The brushes when once adjusted need no changes for any variation of load. The bearings are self-oiling and self-aligning. The bearing supports and bed plate

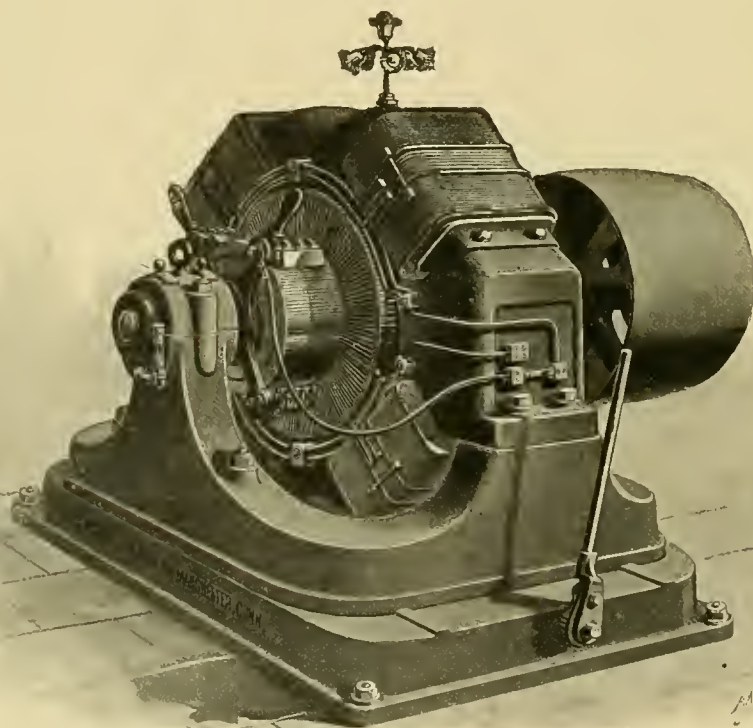

THE MATHER GENERATOR.

are all cast in one piece. The winding of the armature is such that the wires at the end are not overlapped and bunched, but stand out from the core and from each other, so that there is free circulation of air around every conductor. No wires with a high difference of potential are near each other. The makers say that the fields are stronger with relation to the armature than is the usual practice, which is given as the reason of the fixed position of the points of commutation under variations of load. A radically novel point in construction is the use of the fields made entirely of cast steel instead of laminated iron cast into a cast iron yoke. This is along the line of the recent improvements in street railway motors.

THE interest in the evening newspaper increases in proportion to the plainness of the woman who is standing in the street car.

## A TANGIBLE TERROR.

"I'm not afraid," the youngster said,  
"Of any bogy man;  
I don't believe that he exists—  
So prove it if you can."

And then the nurse's ready wit  
A deal of trouble saved;  
"The trolley car will catch you, sir,"  
She said. And he behaved.

—Indianapolis Journal.

GAY old Mr. Gormley, of New York, has reached the age of 104 and just suffered his first street railway accident. His shoulder was broken, but the bone knit again and Mr. Gormley says he is good for another hundred years.

B. J. ARNOLD has removed his offices from the fourth floor to room 576 of the Rookery, Chicago.

AN old colored woman, once the nurse of a prominent Chicagoan, was invited by her former ward to spend the last days of her life in the Lake city. Aunt Jennie duly arrived and was met by the gentleman, who had to make a few purchases on the way home. The old woman was much interested in the cash conveyors as they skimmed back and forth from the cashier's desk, propelled by the clerk's lever. Arriving outside, her attention was attracted by a passing cable train, which greatly increased her astonishment. "Wonderful, isn't it, Aunt Jennie?" remarked the man, as he noted her interest in the train. "'Deed it am, Massa Chawles," she responded, still having the cash conveyors in mind. "Mus' 'a been a powahful push dey gib dem cahs to make 'em go so fast an' keep a-goin' so long."

THE STEEL MOTOR.

For several years the Steel Motor Company, of Cleveland, has been engaged in the manufacture of repair parts for all the existing makes of motors, and now is on the market with a motor of its own. It has, of course, been in an excellent position to observe the undesirable features in present types, and has, accordingly avoided them as much as possible in its own motor. The designers have tried to produce a substantial motor of few parts, simple in construction, and with

The series parallel controller used with this equipment is known as "Type C." It has a novel arrangement whereby a single motion of the reversing lever to a point indicated, converts it into a multiple controller, after the old style. This, in connection with the double fuse box contained in the controller, makes it possible to cut out either motor in a few seconds without leaving the platform. In addition to the regular discs separating the contacts, vulcabeston guards are inserted between them. These guards are hinged at the side of the controller, so as to be readily thrown back when the jacket is opened.



VIEWS IN THE FACTORY OF THE STEEL MOTOR COMPANY, CLEVELAND.

all parts which require renewal, of great wearing surface, but cheaply replaced. The company claims it to be the lightest motor per horse-power actually delivered to the axle of any in use.

The armature is drum type, and contains ninety-nine coils wound in slots, the wire being carried well below the surface of the core; ample provision is made for perfect insulation.

The fields are wound on metal shells, thoroughly insulated, and by an ingenious arrangement of the pole pieces, the armature or either of the fields can be removed independent of the others.

The manufacturers have not pushed the sale of this motor until recently, preferring to await the test of actual service before advertising it extensively. They have now been running two years on difficult roads, and have proved themselves durable and efficient. The Cleveland Electric Railway is running 100, and 120 have been ordered by the Nassau Electric Company, of Brooklyn, N. Y. A fourth order has been completed, for the Allentown & Lehigh Valley Traction Company, which has eighty in use. There are also a large number on smaller roads over the country. This company is the successor of the Johnson Electric Company, of Cleveland.

A. L. Johnson is the president, and Samuel Harris general manager. Both of these men are of long experience in the street railway business, and patrons of the company can have every assurance that its affairs are not in

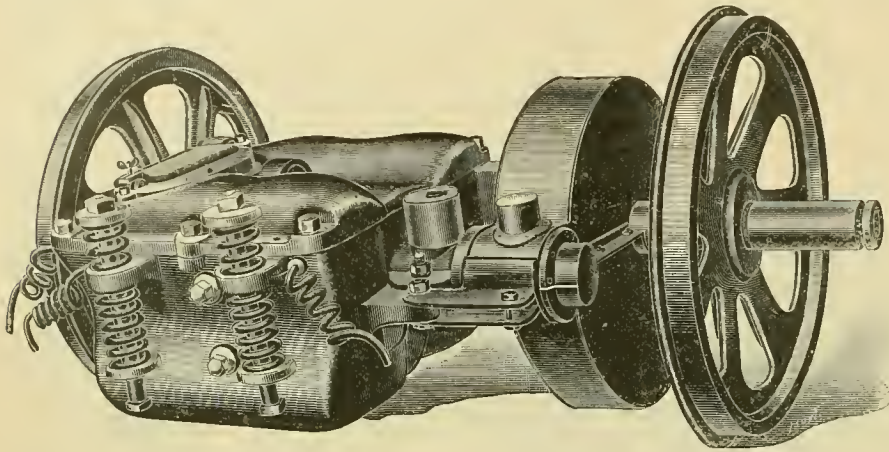

novice hands. The well equipped factories, of which views are here presented, are now very much crowded filling orders, and are obliged to run two nights of every week.

THE Baltimore, Md., Traction Company will soon begin the construction of an electric line through South Baltimore, and President Brown intends to connect Baltimore and Gettysburg, Pa., by building a trolley line through Westminster and other towns of western Maryland.

THE Reis Electric Specialty Company, of Baltimore, Md., for which a receiver has been appointed, has filed a deed of trust for the benefit of its creditors, in compliance with an order issued from Circuit Court No. 2. Bernard Wiesenfeld and Sylvanus Hayes Laucheimer, who were appointed receivers, qualified in the sum of \$15,000 each.

THE Stanwood Manufacturing Company of Chicago has a shop full of repair work and finds this season a most profitable one on account of the economy practiced by street railways in all quarters. Repair work in every department is on the increase, and the Stanwood methods and reputation for good work are keeping old and adding new clients.

THE Randallstown, Md., Rapid Transit Company has been reorganized and will construct an electric line from Randallstown, Md., to Pikesville, Md. The president is Dr. H. J. Hebb, and the secretary and treasurer is James G. Floyd, of Baltimore, the agent of the Barrow elevated railway system. These, with E. S. W. Choate, Aaron Weber, of Baltimore county, and Thomas Barker, B. G. Underwood and W. H. Tylee, all of Massachusetts, and representing the Northern syndicate which has combined with the Baltimore county people for the construction of the road, were elected officers.

## NEW PUBLICATIONS.

'ROUND AND THROUGH THE WORLD is a neat little brochure, is by J. G. Pangborn, director of the railway department of the Field Museum, giving the itinerary of the commission which is about to start for a trip around the world, investigating the transportation facilities of the various countries of the world. The trip will take two years and the commission will consist of Major Pangborn, a mechanical expert, a navy officer, a draughtsman and artist, a photographer, and a stenographer. They travel in the interests of the museum.

THE Westinghouse catalogue Number 64, treats of the Westinghouse stopper lamp, the lamp which lit the World's Fair and which broke the monopoly which was at one time threatened. They are now better prepared to meet orders than formerly.

## TRAVEL ON A FOUR-MILE ROAD.

It seems to be the fate of Chicago roads that they shall carry passengers, and carry them in great abundance. The Twenty-second street electric line, owned by the Chicago General Street Railway, is a good example of this. The line is purely a local one and runs from the Twenty-second street bridge west to Lawndale. It does not give transfers to lines running down town, although it connects with several. The east end of the route is through a lumber and factory district and the west end a suburban residence territory. The accompanying table shows the traffic for the weeks beginning each quarter during the year ending June 30, 1894. During the first two-thirds of the year only about two miles were laid and horses were used until November, 1893.

Week ending July 8, 1893.....	352 passengers.
" " Oct 7, " .....	855 "
" " Jan. 6, 1894.....	4,073 "
" " Apr. 7, " .....	9,916 "
" " June 30, " .....	22,989 "

THE Austrian ministry of commerce has granted a concession for an electric railway from Abazzia via Ika to Lovrana.

## C. E. LOSS & CO., General Railway Contractors.

Estimates made on all classes of Engineering Work.

621 Pullman Bldg.

CHICAGO.



WINDSOR & KENFIELD,

PUBLISHERS AND PROPRIETORS,

269 DEARBORN ST., - - - CHICAGO.

Published on the 15th of each month.

SUBSCRIPTION, - - - TWO DOLLARS.

FOREIGN SUBSCRIPTION, - - - 20 SHILLINGS.

Address all Communications and Remittances to THE STREET RAILWAY REVIEW,  
269 Dearborn Street, Chicago.

H. H. WINDSOR,  
Editor.

F. S. KENFIELD,  
Business Manager.

**CORRESPONDENCE.**

We cordially invite correspondence on all subjects of interest to those engaged in any branch of Street Railway work, and will gratefully appreciate any marked copies of papers or news items our street railway friends may send us, pertaining either to companies or officers. Address:

THE STREET RAILWAY REVIEW.

269 Dearborn Street, Chicago.

Eastern Office, Room 14, No. 126 Liberty Street, New York.

This paper member Chicago Publishers' Association.

Entered at the Post Office at Chicago as Second Class Matter.

VOL. 4.                      SEPTEMBER 15, 1894.                      NO. 9.

J. A. CRILLY, Hartford, writes us the scheme of telephoning from electric cars in motion, as exploited in the eastern papers, is an unadulterated fake.

AS USUAL, in this our annual pre-convention number, we have given considerable space to a description and illustration of the principal points of interest, both along the route to and at the convention city. Our readers are thus in advance fully posted as to the city they will visit, and go prepared to know the gentlemen they are to meet but have never seen, as well as to be fully posted on the history and present resources of Atlanta.

WE inaugurate, this month, a new department, which, as its head implies, is devoted exclusive to power house matters. The engineer, the fireman, and the electrician will all find practical subjects discussed by practical men, in a simple and practical style, and we feel sure it will be found of equal value to the manager and builder of machinery as well. We specially invite the boys in the power house to contribute freely to this, their especial department of the REVIEW.

CONVENTIONS multiply—Ohio, New York, Pennsylvania, Maine, Connecticut, and now the Michiganders. State conventions are, in many respects, most excellent affairs and capable of much good. We believe, however, that if they were held in the winter, spring or summer,

it would be better than to crowd them all into the month next preceeding the annual of the American, especially as in some states the meeting takes the best part of three days. Why not change the date?

A NEW scheme for preventing accidents is proposed by some scintillating intellect masked as "H. T. C.," through the columns of the Cleveland, O., Leader, who says: "Since women nearly always are cumbered with packages, and use their right hands regardless in getting on or off cars, let the cars be run on the left instead of the right hand track, so obliging passengers to get off on the left side of the car, and making it natural and easy for both men and women to seize a grab handle for that purpose with the right hand, and alight face forward." Now, H. T. C., why not amputate the offending member. It would be much easier and cheaper.

THE supply men are hustling to present an unusually complete and attractive exhibit at Atlanta, and deserve a liberal share of the time of the visiting delegates. The expense and time necessary to provide this most valuable department of the meeting is much greater than the visitor in the rush and excitement of the meeting is apt to realize, and we thus early bespeak for the supplyman, who is ever the life of the convention, the considerate attention and a reasonable portion of the managers' time. We suggest that all who can do so arrange to reach Atlanta Tuesday noon, at the latest, which will give an extra half day for the inspection of displays.

WE recently had the opportunity of looking over the expenses of a small electric road operating from five to seven cars over a level track, and were agreeably surprised on finding that the cost of operating was only a trifle over 13 cents per car mile; and this, too, in spite of the fact that the wages paid conductors and motormen were very high, and the price of coal was over \$2 per ton. This figure includes all expenses but fixed charges. The road is a new one and the maintenance account is, of course, low, but as the equipment is first class in every respect, it is not unreasonable to suppose that the present expenses will be raised very little for several years to come. Such a low figure is one that could not have been obtained a few years ago, even from a large system, and the fact that a small road, not under the most favorable conditions, can now do so well, is the most positive and gratifying evidence that can be obtained of the substantial progress that has been made in electric railroading within the past few years.

AND next month the convention! It seems scarcely two months since the departing echoes of our partings at Milwaukee died away, and now we catch the welcome voices of Atlanta hosts, bidding welcome the whole street railway world. Everything has been done, all arrangements made, and the well-known hospitality of Atlanta is freely tendered. The street railway fraternity should make an extra effort to turn out in full force and express by an

overwhelming attendance their appreciation of this most kind invitation. That the meeting will be the most largely attended of any yet held, all signs indicate; and in value of papers to be presented, excursions to be enjoyed and exhibits to inspect, the thirteenth annual promises to be a record breaker. For the first time the convention journeys to the far South, and, as it will, probably, in the usual order of selection, choose some eastern meeting place for next year, the chance is one to visit this beautiful country which may not occur again in several years. Let everybody then, with everybody's wife, and his superintendents and managers, and just as many others as can be spared, stick a few stakes of variety in the monotonous rush trips of life, and breathe another air and get some new ideas in this, the great opportunity of the whole year.

THE acts of violence and the misdemeanors committed by the strikers at San Antonio, last month, have aroused no little public indignation, in all parts of the law abiding South. The failure of the San Antonio authorities to quell the riot, and to prevent the wanton destruction of property by the mob of employes and their coadjutors, has called forth from all sides the severest censure. Municipal misrule seems not to be confined to Youngstown, Ohio, and Chicago, but that fact is no excuse for the violation of pledges of office in even the smallest hamlet in the country. The city authorities of Youngstown have done more by their inaction and cowardly indifference to injure the city than years of hard times or any amount of severe fire losses. With San Antonio the same proposition holds true. If these cities expect to become centers of manufacturing or any other industry, protection must be guaranteed against mob violence, and this protection ultimately resides in the citizens.

MORE good than a week's vacation does it do the electric railway man to peruse the following words of wisdom from the St. Louis Republic, which most pointedly rebukes an eastern mossback:

"In a recent issue of a New York paper, a half page of presumably valuable space was devoted to an attack on the trolley car idea. A sensational writer went into spasms over a speed of 16 miles an hour in the suburbs, employing the following humorously vague sentence:

'Onward with noise and dust, and the wild clangor of the alarm bell ringing out on the night air, we plunged, ever forward.'

"In the name of all the superb trolley cars of this city, that put us into our homes in half the time formerly employed, did this writer expect to plunge any way but forward? Did he want a reverse motion or did he think that it is within the line of the motorman's duty to experiment with the aeroplane idea?

"Such sensational nonsense as this is ever to be found in the Eastern papers. Some of these editors ought to come into the West and learn of the comforts of the street railroad system, chiefly of the trolley car brand, that we have here in this city of biggest and best of things.

"The trolley cars of St. Louis are not deadly, and the service that they offer is well nigh perfect. A car may kill a man if he lies down on the track and gets run over; but even if he were foolish enough to do such a thing, the chances are that the motorman would stop the car before harm was done.

"The Mississippi River and the Atlantic Ocean are dangerous things, but they have their uses. Everything is dangerous to people who don't use eyes and sense. The trolley is much less dangerous than buggy horses. The East will shiver a year over dreaded dangers and then drop into the procession."

SOME day, if we ever get time, we are going to write a book on the "History of Home Made Engineering." The usual charge of consulting and supervising engineers is from 2½ to 3½ per cent of the cost of a plant. How on earth street railway officers who don't know a separator from a circuit breaker expect to save this amount by doing their own engineering we cannot see. When, as is sometimes the case on large systems, the men in the regular employ of the company are as competent as any outsiders that could be hired, and have in addition an intimate knowledge of the special needs of the road, it is undoubtedly better not to employ outside engineers. There are very few places where this is true, and the majority of roads will get "salted" if they try to do their own engineering. The number that have "salted" themselves in this way is too numerous to count. We heard the familiar old story over again the other day. Some relative of one of the officers, (not an engineer), made a general lay out of what was wanted for a new plant. The contracts were let to different makers to put in the machinery as best they could, and finally the contract was let to a firm of plumbers to put in the piping according to their own plans. The plumbers did not know enough to make the piping plans themselves, so they hired another firm to draw the plans for them. The result can be imagined, a plant that is a cross between a junk shop and a saw mill. The company now wishes it had hired a responsible head for its construction, and admits that money would be saved by it.

THE most noticeable point in the street railway practice of Atlanta, is the large amount of material that is manufactured by the Consolidated Street Railway Company for home consumption. The local conditions which bring about home made supplies, are first, the great distance to the manufacturing centers and the proximity to raw material. It would be altogether a hazardous proceeding for a northern and western street railway company to make an attempt at supplying its own car wheels, trolley wheels, gears, pinions, etc. While it might stimulate invention, there is no question that the product at best would be more clumsy and less efficient than the professionally made article. There is perhaps an excuse for the manufacture of some of the above named articles in the far south, but why, ye supply men, is this thus? If there is a discrepancy in freight rates, would not it be entirely proper to bring the matter to the attention of the railroad powers that be. If freight can not be arranged, a little money and management, consolidated with some already established southern manufacturing enterprise, ought to return good interest in the investment. The future of street railways in the south is a wide one. Already several new enterprises are entering the land to possess it, and Florida, Georgia, Alabama, South Carolina, Mississippi and Louisiana, are rapidly getting to the front. It is not a far fetched opinion that a little money judiciously invested in connection with established machine shops would be of advantage.



## THIRD ANNUAL MEETING PENNSYLVANIA STATE ASSOCIATION.

The third annual gathering of this association occurred in Reading, at the Neversink Hotel, and occupied two days, September 5th and 6th. It was the most largely attended of any of the state meetings, and the only event to mar the pleasure of the gathering was the recent death of its president, R. H. Rhoades. The president's address was delivered by Vice-President R. E. Wright, of the Allentown and Bethlehem Rapid Transit Company, and two papers were presented—one "The Perfection of Street Railway Motors," by Lincoln Nissley, general manager Citizens' Passenger Railway, Harrisburg, and "Power Stations," by L. H. McIntire, general manager of the People's Traction Company, Philadelphia. Those subjects were discussed by a large number of members. In the evening, a concert was tendered the delegates by the Reading Traction Company, and Thursday morning was devoted to the inspection of the exhibits at Metropolitan Hall. In the afternoon, a very delightful excursion was made over the Mountain Gravity Road, and later in the day another trip was taken over the Neversink Mountain. The hosts of the convention left nothing undone to contribute to the pleasure of their visitors, and both from a business and social standpoint, the meeting was the most successful in the history of the association. The following officers were elected for the ensuing year:

- President, John A. Rigg, Reading.
- First vice-president, Robert E. Wright, Allentown.
- Second vice-president, G. A. Greenwood, Pittsburg.
- Secretary, S. P. Light, Lebanon.
- Treasurer, W. H. Lanius, York.
- Executive committee: Chris. L. Magee, Pittsburg; B. F. Myers, Harrisburg, and J. J. Patterson, Lancaster.

### THE SUPPLY CONTINGENT.

The supply men were fully represented, and the largest display ever accorded a state convention was very much in evidence throughout the convention. The newspapers and street railway magazines were also present by representative. Among the supply men present were: C. P. Breeze, Philadelphia, of the Walker Manufacturing Company, Cleveland; C. W. Bragg, Philadelphia, of the Westinghouse Manufacturing Company, Pittsburg; Newton Clark, representing the old reliable Smith, of New York; E. F. DeWitt, of DeWitt & Co., Lansingburg, N. Y.; Harvey Ellis, of the Ellis Manufacturing Company, Philadelphia; Arthur W. Field, Boston, in the interest of Peckham's trucks; W. F. Forby, of the Okonite Company, New York; John M. Field, of the Berlin Iron Bridge Company, East Berlin, Conn; G. H. Fisher, of Philadelphia, representing C. A. Schieren & Co.; L. R. Faugh, of A. Whitney & Sons, Philadelphia; A. T. Gahagan, of Warren, Webster & Company, Cambridge, N. J.; R. S. Jerome, Central Electric Heating Company, New York; E. J. Lawless, New York agent of the American Car Company; John F. Ostrom, Philadelphia, of the Pennsylvania Steel Company; H. N. Ransom, Consolidated Car Heating Company, Albany, N. Y.; J. K. Randenbush, Eureka Sand Box Company, Lebanon, Pa.; A. C. Vosburgh, New Process Rawhide Company, Syracuse, N. Y.; H. E. Webb, Pittsburg, of the Solar Carbon Company; Jay Wiley, of the Western Electric Company, New York, and H. C. Kellogg, of Alfred F. Moore. The newspaper men were F. S. Kenfield, of the REVIEW; J. W. Nagle, the Car, Philadelphia; J. W. Dickerson, of the Street Railway Gazette, and H. W. Blake, of the Street Railway Journal, New York.

Insulated electric wire manufacturers came from the Philadelphia office: Theodore Mace, Philadelphia salesman for J. A. Roebling's Sons; C. E. Barrett, of Hale & Kilburn Manufacturing Company, Philadelphia; W. C. Jennings, of the Fairbanks Company, Philadelphia.

### THE EXHIBITS.

Metropolitan Hall was nicely decorated and contained the following exhibits:

The General Electric Company showed two G. E. 800 motors on a Peckham truck with a type K controller, together with a line of overhead supplies and accessories. H. J. Crowley, D. L. Huntington and R. E. Moore were present.

E. F. De Witt & Co., of Lansingburg, N. Y., showed their well-known sand box now in use on forty roads.

The Berlin Iron Bridge Company illustrated the anti-condensation roof lining so well known.

Chas. A. Schieren & Co. had as usual a fine display of belting.

The Hubley Manufacturing Company of Lancaster had a fitting display of overhead material and a new car brake handle.

The Western Electric Company showed a full line of elegant overhead material.

C. G. Smith, of New York, made a beautiful display of all sorts of light.

The Safety Clutch Brake Company, of Philadelphia, had an operative exhibit of its excellent brake.

A. Whitney & Sons, of Philadelphia, showed a fine lot of car wheels.

The Mark Railway Equipment Company, of Chicago, displayed track construction.

Macan & Co., agents of the Magnesite Sectional Covering Company, Ambler, Pa., had a fine exhibit.

The Eureka Sand Box Company, of Lebanon, Pa., showed an operative sand-box.

The Okonite Company, New York, distributed Okonite pocket books.

The Consolidated Car Heating Company, Albany, N. Y., had an extensive exhibit that attracted great attention.

Warren, Webster & Co., Camden, N. J., showed how feed water should be heated and purified a la Webster.

In the Hubley exhibit was also shown the Johnson rail bond made by John A. Roebling's Sons Company, of Trenton, N. J.

The Brooklyn Car & Veneer Works, of Brooklyn, N. Y., showed a full line of railway car wood work in charge of W. B. Le Van, Jr., and S. P. Ferner.

The Storm Manufacturing Company, of Newark, N. J., makes the H. & C. sleet cutting trolley wheel, of which John H. Graham & Co., 113 Chambers street, New York, are sole sales agents. C. A. Hoagland was in charge. Lack of space forbids the mention in particular of a large number of other exhibits which were both interesting to themselves and nicely arranged. The association is to be congratulated upon its very successful convention and its efficient and zealous officers and directors, both past and present.

## NEW PUBLICATIONS.

THE Babcock & Wilcox Company, 29 Cortlandt street, N. Y., has issued its Twenty-eighth edition of "Steam." This book is published in English, German and French. It has become a standard work, the publishers say, in nearly all of the schools of technical engineering in this country.

THE Engineering Society of the University of Michigan, is out with its magazine, "The Technic '94." It contains several interesting articles.

CATALOG No. 67 of the Westinghouse Electric & Manufacturing Company, Pittsburg, Pa., treats of multipolar generators and motors from  $\frac{3}{4}$ -horse-power up.

LIPPINCOTT'S MAGAZINE, for September, has a novel which deals with the philanthropic work of the Salvation Army. "Captain Molly," by Mary A. Dennison. The other features are up to the standard of the magazine.

THE railway department of the Central Electric Heating Company, 26-28 Cortlandt street, New York City, has issued Catalog No. 2, showing its American electric heating system.

THE verbatim report of the twelfth annual meeting of the American Street Railway Association, held at Milwaukee, October 18 and 19, 1893, has reached us. The book contains 210 pages, and is embellished with a steel engraving of President D. F. Longstreet.

POOR'S MANUAL, for 1894, being the twenty-seventh annual edition, has been issued. The department of street surface railways has statements of the history, mileage, equipment, operators, income and capital accounts, directors, officers, etc., of the street railway systems and traction companies of the fifty leading cities of the United States. There

is also an exhaustive treatment of the city and suburban tramways of Massachusetts, New York and Pennsylvania. The high standard and accuracy of the information contained in Poor's Manual is conceded by all who are familiar with the work.

### THE WESTERN ELECTRIC IN THE RAILWAY FIELD.

No one who has known anything of electrical progress is ignorant of the rapid strides made by the Western Electric Company, of New York and Chicago. It is now rated among the largest electrical houses in the world, and stands high in popular favor. The



WESTERN ELECTRIC COMPANY'S BUILDING.

most enduring monument that it has erected, other, of course, than its reputation for good goods and square dealing, is its New York building at the corner of James and Greenwich streets, represented in the accompanying engraving. Here the policy of the company and its dependencies is shaped and the larger business transacted.

Recently, the Western Electric has entered the electric railway supply field, and has placed in stock a complete line of overhead materials of all kinds. The new goods will be in every point up to the standard of the company's other specialities. Three distinct lines of materials will be carried, namely, the cap and cone, the West End, and the Western Electric types. In addition to this, there will also be carried a stock of tools, construction material, testing instruments and car, station, and workmen's supplies. By this arrangement any construction or railway company may buy of one firm all things necessary except dynamos and motors.

All of the Western Electric material will be fully guaranteed and of the highest quality of material and workmanship. In fact, the reputation of the house is to be sustained in the railway field, and this requires all that a guarantee implies both as regards quality and finish.

The Western Electric type of hanger is a modification of the West End and fully described elsewhere in a separate article that deserves particular attention, as it also details a new section insulator and insulated cross-over. The company has in press a railway supply catalog of 110 pages, which will be sent to street railway men on demand. It will also illustrate the repair parts, construction material and tool station supplies, and the three lines of overhead materials indicated. It will be a handsome affair, as befits the company in whose interests it is issued.

The headquarters of the railway department are in New York, and are conducted under the able direction of E. M. Scribner, assisted by Jay Wiley.

### PRAIRIE CHICKENS.

Recent reports received by the Chicago, Milwaukee & St. Paul Railway, from stations in the prairie chicken country of Minnesota and South Dakota, all indicate a prospect of the best hunting for years. Chickens are very plenty and in fine condition. Duck shooting prospects are also good.

Full information can be had by addressing Ticket Agent of Chicago, Milwaukee & St. Paul Railway, 207 Clark street, Chicago.

### CHEAP EXCURSIONS.

On October 9, 1894, the North-Western Line will sell home-seekers' excursion tickets to points in northwestern Iowa, western Minnesota, North Dakota, South Dakota, Manitoba, Nebraska, Colorado, Wyoming, Utah, Idaho and Montana, at exceedingly low rates for the round trip. These tickets will be good for return passage within twenty days from date of sale and will allow stop-over privileges on going trip in territory to which tickets are sold. For tickets and full information apply to agents Chicago & North Western Railway.

## PERSONAL.

SAMUEL J. WICK, of the Electric Railway Equipment Company, of Cincinnati, was in Chicago recently.

C. R. MARCHANT, business manager of the Manufacturers Record of Baltimore gave the REVIEW a call this month.

J. G. CARROLL, of the Bangor, Me., Public Works Company, is reconstructing the Ann Arbor Street Railway.

GENERAL MANAGER JOHN YOUNG, of the Glasgow, Scotland, tramways, writes that the reports of carrying city refuse on the line of the tramway are untrue.

W. F. MILLHOLLAND, secretary and treasurer of the Citizens' Street Railroad Company, of Indianapolis, made a welcome visit at the REVIEW office recently.

ALEXANDER VON SIEMENS, of Siemens Brothers & Co., London, was a visitor in Chicago during July, and the guest of O. W. Meysenburg, president of the Siemens-Halske of America.

CHARLES GROVER was recently appointed electrical engineer of both the Metropolitan and Elevated Railways, of Kansas City. He has been connected with the Metropolitan for some time.

EVERETT K. DAY, formerly of the Mousam River Railroad, of Sanford, Me., is now superintendent of the Pawcatuck Valley Street Railway, at Westerly, R. I., a thriving summer resort road.

HENRY G. ISSERTEL has accepted the position of electrical engineer and general sales agent for the electrical department of the H. W. Johns Manufacturing Company. He has already closed several large contracts for trolley line materials.

J. K. URIE has resigned the management of the Austin, Tex., Rapid Transit Company, and has assumed the superintendency of the Galveston City Railway. Mr. Urie is one of the foremost street railway men in the South, and Galveston is to be congratulated.

A. M. JOLLY, who recently retired from the position of general manager of the Wheeling Railway Company to look after his former street railway interests at Beaver Falls, Pa., was agreeably surprised a short time before he left, by a party of his employes who stormed and captured his residence, and presented him with a silver dinner set.

"WHAT is your line of business?" whispered the editor to a man he was about to introduce to Northern capitalists.

"I drives a buss," huskily came the reply.

"Here, gentlemen," continued the editor, "is Mr. Jones, one of the moving spirits of our city."

## OBITUARY

PAYSON K. ANDREWS.

Payson K. Andrews, Chicago representative of the American Car Company, died at his home in this city, August 22, of heart disease.

There was no better known or better liked man in the supply trade than Mr. Andrews, and his death is deeply regretted by his very many friends, in and out of the trade. Since 1882 he has been a familiar figure at street railway conventions. He was born in Massachusetts, and after serving an apprenticeship in steam engine building, went on the road for various firms in the supply business.



P. K. ANDREWS.

For a long time he represented the Brill Company in the west. "Pay," as the fraternity loved to call him, was of a quiet, unassuming disposition, but possessed many rare qualities, and a man who loved his home. He was generous to a fault, of a most kindly nature and genial disposition, and always an active but honored competitor in business matters. It was a sincerely sad company of railway men who attended the funeral services, and each felt the loss of a personal friend. The remains were taken to Andover, Mass.

WILLIAM J. STEPHENSON,

the president of the Metropolitan Railway Company, of Washington, D. C., died August 31, at the age of 53.

Mr. Stephenson, who was first vice-president of the American Street Railway Association, was born in Washington, and a steam railroad man by education. His managerial ability was unusual, and his investments in street railway securities particularly fortunate. He owned stock in the belt line, the Columbia Street Railway, and the Metropolitan. Of the Columbia line he was manager, and of the Metropolitan the president, since last July.

Mr. Stephenson was an indefatigable worker, a genial friend, and devoted to enterprises having the public weal in view. He was a prominent mason, and past master of Dawson lodge, and past eminent commander of the Washington Commandery of Knights Templar.

GEORGE B. SHAW,

well known to the electrical fraternity as connected with the National Electric Manufacturing Company, and as manager of the Ansonia Entertainment Club during the World's Fair, died August 27, at the age of 40. Mr. Shaw was several times returned to Congress by the Republicans of the Seventh district of Wisconsin, and was made supreme chancellor of the world of the Knights of Pythias, in July, 1890. He was a brilliant man, of great promise, and his death is regretted by a very large circle of friends.

## DEATH OF WALLACE H. DODGE.

Wallace H. Dodge, founder and president of the Dodge Manufacturing Company, Mishawaka, Ind., died September 10, at his home. In 1889 he returned from Europe, where he went as delegate of the Society of American Engineers, with an attack of inflammation of the bowels, from which he never fully recovered. He was born in Mishawaka, in 1849, and all his life was spent there. He began business in his father's hardware store, and later engaged in manufacturing. In 1881, in connection with George Phillion, he made some wood split pulleys, and from this beginning the Dodge Manufacturing Company, the largest manufacturer of wood split pulleys in the world, sprung and its product is sold in nearly all parts of the world.

---

**HALF FARES.**

Interesting Bits of Information from All Parts of the Country,  
Boiled Down for Busy Readers.

A HEAD collision on the electric lines, at Whiting, Ind., occurred during a dense fog, killing one and injuring eight persons.

IN a collision of an electric car on the Cicero & Proviso line, this city, with a steam locomotive, Motorman John Briggs was killed and the street car wrecked.

THE Street Railway and Electrical Reporter, after reporting for two consecutive issues, has gone bust. It's hard to fill a long-felt want which is neither long nor felt.

G. VAN GINKEL, the prominent street railway capitalist, who was interested in the roads at Des Moines, Ia., Brazil, Ind., and elsewhere, was struck blind on the streets of Des Moines, September 17.

THE Newark Consolidated Street Railway Company recently sold its surplus horse flesh to the number of 500 head. The horses brought from \$15 to \$50. Farmers and peddlers were the main purchasers.

THE unfortunate San Francisco & San Mateo Electric line has had another runaway, this time its handsome funeral car. The car was on return trip from the cemetery, and the accident furnished one or two fatalities.

WELLINGTON ADAMS, in his suit against the General Electric Company for infringement of railway patents, received an adverse decision from Judge Hallett in the district court at St. Louis, September 17. The case will be appealed.

THE Indianapolis & Broad Ripple Rapid Transit Company, of which R. C. Light is president, and William Bosson, secretary and treasurer, began running cars September 14. The road gives every evidence of a prosperous career, and the promoters, among whom R. C. Light was chief, are to be congratulated.

THE San Antonio, Tex., Street Railway Company reports the following list of officers: President, W. H. Weiss; vice-president, T. C. Frost; D. D. Willis, superintendent, and Frederick Bolton, assistant superintendent.

OCTOBER 1 is the date set for the emancipation of all the remaining car horses in Cincinnati. How to get rid of the old horse cars, is a question that is bothering the management. Some are being sold for children's playhouses and summer kitchens.

THE Chicago City Railway has distributed a pocket card, asking the co-operation of patrons to prevent the "hitching on" evil. The request is made that papers be purchased before getting on the cars and not on the cars. On August 18 twenty-five boys were arrested for "hitching on."

PRESIDENT H. H. VREELAND brands as false the report that the Metropolitan Street Railway Company is about to put uniformed newsboys on the trains of the Metropolitan Traction Company's cable lines in New York. Some wise correspondent has spread far and wide the information that this was to be done.

JUDGE SWAN, of the United States Circuit Court, at Detroit, in a decision rendered August 21, denied the motion for a rehearing in the Cody patent case, thereby affirming a previous decision of the same court in favor of the Consolidated Car-Heating Company, of Albany, N. Y.

THE power house which is to run the electric locomotives in the Baltimore belt tunnel of the Baltimore & Ohio Railroad will be built at the south end of the tunnel on South Howard Street. The capacity will be 12,000 horse-power, and the generators are being built by the General Electric Company.

JOHN OLIPHANT, JR., superintendent of the Calumet Electric Railway, of this city, has compiled and issued one of the most compact and useful guides to "Points of Interest" on his line that we have seen. It contains a good map, time tables, and notes on pleasure resort points, and makes prominent their motto: "A pleasure ride of 40 miles for 20 cents."

THE formation of a Canadian Street Railway Association is being discussed by the brethren across the line. The plan would seem an excellent one, as owing to the latitude and municipal and other purely local features, there are many matters of considerable importance to Canadian managers which are not of sufficient importance to command the time of the American Association.

A SINGULAR accident befell a Brooklyn bridge cable car on August 4. The rear truck of the rear car of the train of four, jumped the track and mounted the guard rail. The car body fell off from the truck and rested partly on the rail and partly on the road below. The forward truck kept the track, but the rear one turned a

summersault and landed bottom up on the masonry at the side. A broken side bearing falling on the track is said by the press to have been the cause of the accident.

A PENNSYLVANIA judge has ruled that, while county commissioners have authority to grant electric railway franchises over county roads, they may not give such consent as to bridges along these same highways. The good judge is away off, as higher decisions already establish the fact that once the bridge is built and used, it is just as much a public highway as any other portion of the road.

THE annual meeting of the Ohio State Tramway Association will be held on Wednesday, September 26, at Toledo, O. The meeting will be called at the Beebe House, and if the delegates are in the city early enough arrangements may be made to hold the meeting upon a boat running to the Islands, which trip can be made probably, with the return, in one day. The secretary, J. B. Hanna, of Cleveland, or A. E. Lang, president of the Toledo Consolidated, will be in charge of affairs.

SUCCEEDS W. J. STEPHENSON.

Samuel L. Phillips has been elected president of the Metropolitan Railroad Company, Washington, D. C., succeeding William J. Stephenson, deceased. Mr. Phillips entered on his duties September 15. He was at one time a leading member of the Washington bar, but about twenty-five years ago his private affairs demanded so much of his attention that he gave up his practice to supervise matters in which his capital was invested.



SAMUEL L. PHILLIPS.

His first venture in the street railway field was as president of the Third Avenue line in New York City, which was \$400,000 in debt. Under his administration dividends began. Mr. Phillips was also president of the Washington and Georgetown line, Washington, D. C. Although he has been in the harness only a short time, the results of his administration are being felt. He first relieved conductors from the duty of washing car windows, placing a man at each end of the line for that work.

Mr. Phillips says the road will soon be equipped with the best underground electric system that can be procured, regardless of cost. He is investigating thoroughly all systems, and is ready to invest in everything that will improve the equipment of the line, and will soon fit the cars with fenders. New cars are in the barns ready for use in the winter season. From this showing it would seem that the presence of the new president is a great acquisition to the Metropolitan Company.

A WATERMELON FESTIVAL IN ALABAMA.

J. B. McClary, superintendent of the Birmingham Railway & Electric Company, of Birmingham, Ala., kindly sends the accompanying unique advertisement of

MOONLIGHT WATERMELON FEAST,



W. H. LANE

Given away by LANE BROS., at Lanesville near Thrash Station on Ensley Dummy line Every Thursday night that the moon shines the feast will begin at 8 p. m., and last until midnight.



J. H. LANE.

NOW IS THE TIME

Young ladies and gentlemen to have all the fun you are looking for at Lanesville where the fine fresh watermelons are cut every Thursday night that the moon shines.

THE WATERMELON FEAST

Is the town talk. I believe all the ministers of the city go out. Lanesville is the proper place to go for pleasure. Everything is handy and in first class style and best of all, the very best order is observed.

OH, YES!

I've just found out why so many people go aboard the Ensley Dummy every pretty moonlight night. I could have told you long ago that every Thursday night that the moon shows her face, the Lane Bros. give a watermelon feast to us. You can see the many beautiful lights from the Dummy.

(OVER.)

a park for colored people, established by two wealthy negroes, on one of the lines of the electric railway. As to the watermelon feature, the public may well smile, while as an artistic and literary gem, it certainly is worthy of record.

GUARD AND SCREEN ATTACHMENTS FOR WINDOWS.

Theophile Euphrat, Darien, Connecticut, has recently secured patents for guard and screen attachments, which can be adjusted or applied to old as well as new windows. "It prevents persons from falling out of windows, and thieves from breaking in," says the inventor, "and can be adapted to private houses, offices, etc., and keeps out insects as well as larger bodies." The screen and guard can be used separately or together, and in whatever position the window may be when opened, the opening is protected by the screen.

THE Montreal Street Railway Company has not as yet arranged for street railway postal service. "It will probably not be adopted this year," says Manager G. C. Cunningham.

### MICHIGANDERS MONKEY WITH A KENTUCKY BUZZ-SAW.

And as the Buzz-Saw was on the Right Track they are  
Worsted.

Considerable interest was created in street railway circles by a one-sided report sent out by an unregenerate Associated Press correspondent at Benton Harbor, Michigan, stating that W. Worth Bean, the president of the St. Joe & Benton Harbor Street Railway, had gone gunning for city officials on Sunday morning and deliberately shot one of the city aldermen.

Notwithstanding the outrageous warping of facts as sent out, the members of the great street railway fraternity of the country were not deceived as to the position of President Bean, and expected that when the truth was known his action would be found a warranted one. Such has been the outcome. The story is a long one, but interesting, and in a few brief words may be stated thus:

Five years ago, Mr. Bean purchased the few rails and one or two rattle traps, in which the St. Joe people were given a half-mile shake for five cents, and at once set to work to create both a business and a road. He connected the two cities, extended lines in both, installed a first-class electric system, put on new cars, ran them at a loss for a while in order to give a first-class service, ran his cars early and late to connect with lake steamers, increased the value of other people's real estate by thousands of dollars, installed one of the most extensive lighting systems in Michigan, and all this without a dollar of local aid. He had faith in the enterprise, and the towns, which was more than most people who knew the situation, had, and confidence in his own ability to earn success. So, single handed and alone, he worked nights and days (and Sundays, we guess), and has been running on easy street for some time.

But all the way he has had to fight the old foggy ideas of an aggregation of moss backs, veritable dogs in the St. Joe manger. The issue last made was an attempt to break faith with Mr. Bean by two granger members of the council who are on the street committee, by insisting on cedar block paving instead of 3-inch plank, as ordered by the city, and this without law or even resolution of council. Mr. Bean refused. At 4 o'clock Sunday morning the street committee, with three policemen and thirty laborers, proceeded to destroy the track. Mr. Bean appealed to the sheriff, who immediately formed an armed posse, taking Mr. Bean as one. The defense boarded a car, accompanied by Mrs. Bean, who is a no small command herself, and the little army of seven were quickly on the field of action. While the sheriff was endeavoring to make the rioters desist from further destruction of the track, the hammer of Mr. Bean's gun caught on the car gate, and its contents were discharged, two of the shot finding a stopping place in the leg of one of the aforesaid aldermen. It was purely accidental, as has been conclusively proved; and had Mr. Bean been

ordered by the sheriff to fire, would surely have placed the entire load where it belonged. We believe that he was fully justified in defending his property, and, if anything, did less than any man under similar circumstances is justified in protecting his hard earned property. To the credit of the citizens be it said their sympathies are for the railroad.

Mr. Bean is an earnest, progressive man; was one of the earliest members of the American Street Railway Association, and has served it as vice-president and member of executive committee more than once. His friends will be glad of the chance to congratulate him at Atlanta, on having "met the enemy and they are his."

### THE HEILMANN SYSTEM.

There is quite a diversity of opinion to be noted in perusing our foreign exchanges as to the merits and possible future of the Heilmann system of electric propulsion, which was recently described in these columns. The majority, however, strongly incline to the belief that the generation of electricity on the car propelling it has no wide or practical future. As a sample of this latter class of writers, we quote the following from an editorial in the Pall Mall Gazette, which says:

"The so-called electric locomotive which has just made satisfactory public trials in France, is not likely to revolutionize the methods of railway traction in this country. The new machine is indeed scarcely to be described as an 'electric' engine, for though the power is applied through the medium of a dynamo, a boiler and a high-pressure steam engine are essential parts of the appliance. There can, of course, be no gain in power by utilizing the force of the steam engine indirectly; on the contrary, there is a distinct loss though a very small one. The size and weight of the locomotive are exceptional, and there is no evidence as yet that its hauling power is remarkable. The speed is high, but not higher than that of an ordinary express engine. Indeed the chief advantages which appear to be claimed for the French locomotive are greater smoothness of running, and consequently less wear and tear to the rails; and that the driver, being absolved from the charge of the steam engine, can give his undivided attention to the observation of signals and the running of the train. But this seems a small gain in exchange for the complication of the steam engine and the electric engine carried on the same platform."

The REVIEW is firmly of opinion that the tendency will be more and more to a utilization of electric power generated in one central station for an increasingly large territory, and that the car will receive its current through direct connection at all times with the station.

THE general manager of one of the most successful roads in New York, in renewing his subscription, says: "We enclose check for renewal of subscription, and wish we could invest all our \$2.00's as well!"

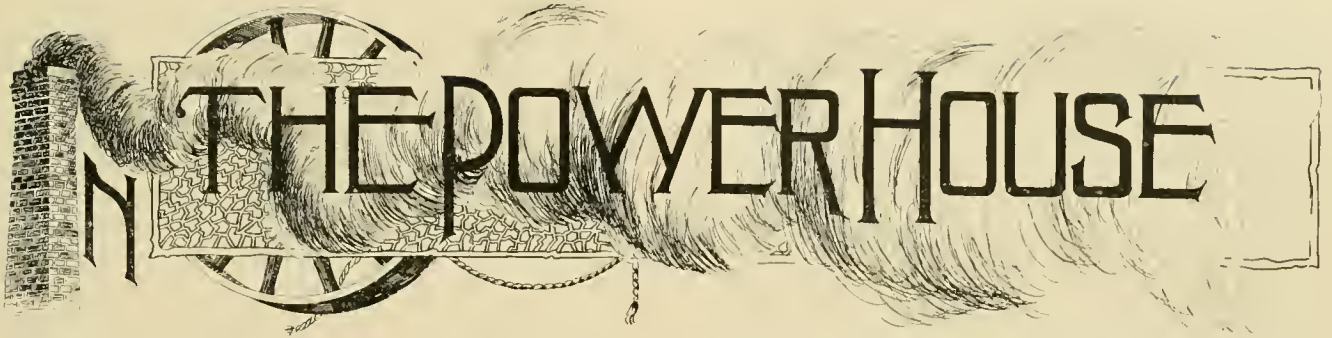

# IN THE POWER HOUSE

*This department is devoted to the construction and operation of electric railway power houses. Correspondence from practical men is specially invited. Both the users and makers of power house appliances, are expected to give their views and experiences on subjects within the range of the department.*

At last America is to have an electric railway station with a storage battery as an adjunct. The Merrill Railway and Lighting Company, of which R. Weidauer is president, and E. S. King secretary, is to be congratulated on the move it is making, and we are sure all will wish for the success of the undertaking and watch with interest for the results. Mr. King's article, elsewhere in this department, gives some of the details of the installation.

\* \* \*

How many engineers know how much their coal and power house expenses amount to per car mile, and how much a horse-power-hour costs at their power house? There are plenty of men who think they have "pretty neat little plants" and can "make about as good a record as the next fellow," but when it comes to actual figures there is a sudden discovery that they do not know much about the performance either of their own or other plants. Those who belong to this class had better take measures to get out of it as quick as they can.

\* \* \*

It is not often that a clutch in breaking, does as much damage as did the one at New Orleans in the Louisiana electric light plant, August 28. The plant runs the Canal and Claibourne Railway lines, and the accident caused the shutting off of the railway current for several hours. The breaking clutch wrecked nearly everything in the vicinity, and even went through a brick wall.

\* \* \*

SOME people seem to be incapable of grasping the fact that the world moves, and engineering practice goes along with it. A company four years ago, built a station of 150 horse-power, using 60 kilowatt generators. Shortly after, it built a slightly larger station with 100 kilowatt generators. The last station it built was of 1,600 horse-power capacity, and, although it was of good design otherwise, the generators are all only 125 kilowatt. It is needless to say that it is not a very efficient station, as compared with what it might have been, had the designers been a little progressive in their ideas. The centralizing of power in large units can be overdone, but

the economical advantages of a large plant are lost if the units are not made proportional to the size of the plant.

\* \* \*

It now seems very likely that before long several railway stations will put in batteries to steady the load on generating machinery and take care of extreme variations. The plant about to be installed at Merrill, Wis., will do several varieties of work, but the advantages would be just as pronounced with a railway station pure and simple. Such use of batteries in railway stations has been talked of in this country for several years, but it was left to Zurich, Switzerland, to try the first experiment along this line. The reason for the slowness of this country in adopting this method is partly in the fact that it is the smallest stations that suffer most from load variations, and such stations are not as independent in practice as the larger plants. The main reason, however, is the uncertainty as to the life of the batteries and a general indefiniteness as to the saving that will be effected. This reason is now no more, as we learn that a certain storage battery company is prepared to make an offer to any railway company that is as definite as can be desired. The proposition is about as follows: Suppose, for example, a road is going to be put in a plant with a maximum capacity of 500-horse-power. Its average load will be about 250-horse-power, and if a battery is used, only 250-horse-power of engines, dynamos and boilers will have to be installed, the rest being taken care of by the storage battery. The battery company proposes to install the 250-horse-power battery for the same money that it would cost to put in an additional first-class steam plant with triple expansion engines to take care of the load were the battery not used. This proposition includes the switchboard and all the regulating appliances for the battery. It is further proposed to maintain the battery for 10 per cent of its first cost, and if the maintenance bill runs below 10 per cent to give the railway company the benefit of it. This is certainly a definite enough offer and guarantee. Now comes the question of the operative economy of the proposed plan. As to first cost there would be no difference if the steam plant was triple expansion in both cases. The maintenance will also be about the same, although the engines in the battery plant ought not to require as many repairs as the others because they work under a steady load. However, machinery is now made so that it will stand the hard knocks of railway work, and the main advantages of the battery will have to be counted

in the saving that will be brought about by giving the engines and dynamos a steady load and allowing them to be entirely shut down during hours when the load is very light. The results of various tests on different roads shows that engines on a street railway load are about 30 per cent less efficient than if on a constant load. Whatever the engines used, therefore, it is safe to count on a saving of 30 per cent in power generation. Against this there is a loss of about 20 per cent of the power that goes through the batteries. Counting roughly that one-half of the output goes through the batteries, this would mean a loss of 10 per cent or one-third of the 30 per cent saving. The storage battery plant, according to this approximate figuring, would therefore have an efficiency 20 per cent higher than the corresponding ordinary steam plant. Although the first cost is not as low as we had been formerly led to expect, this 20 per cent saving in operation is worth trying for, and it is not unlikely that some additional plants will before long install storage batteries. It is also very probable that when it comes to actual business the battery company might better its offer, so as to make a double inducement to install such a plant.

\* \* \*

An explosion of natural gas under the boilers of the West Washington street power house of the Citizens Street Railroad of Indianapolis, on August, 31, did some damage and caused the temporary shutting down of the plant. It occurred at a most unfortunate time, as the traffic for the first half of September is the heaviest of the year. General Manager T. H. McLean, and his right hand man H. B. Niles, the electrical engineer, had been working hard getting this new power plant in condition for the September rush, and were just congratulating themselves on having gotten things into comfortable shape, when the crash came, which sent away for a time all dreams of rest. The load was taken care of by the other power plant of the company, so that the service was impaired very little. A REVIEW representative was in the boiler room at the time of the explosion, and with several others had a narrow escape. Mr. Egan the chief engineer, and a gas inspector, were standing with the REVIEW man in front of the two 750 horse-power Zell water tube boilers with which the power-house is now equipped. When the report came, the three men in front of the boilers concluded that it was not wise to wait there for further developments and started for a door at the other end of the room. "The REVIEW always leads," and this was no exception, as the REVIEW man had the start and kept it to the finish, with the two others close behind. The wisdom of the policy of retreat was afterward fully demonstrated, as the three men would surely have been severely injured had there been an instant's hesitation, for another explosion closely following the first brought down the iron doors and a pile of brick in front of the boilers where the three men were standing. For a few seconds the wreck was an ugly looking pile, as the gas, before it was turned off, flamed up through the ruined

boiler settings, but an absolutely fireproof building prevented a fire. A good idea of the damage done can be got from the accompanying engraving, from a photograph taken by C. D. Jenney, of the Jenney Motor Company, which shows the exterior of the power house the next morning. The wreck which has been cleared away is seen at the left. The setting of the adjoining boiler and the piping were wrecked so that the plant had to be shut down. No one was seriously hurt. The explosion was of course caused by gas collected under the boilers. It could collect there from only two causes—leaks in the pipes under the boilers or a flow of more gas than there was oxygen of the air present to burn. The fact of a previous momentary increase in the gas pressure makes the



NATURAL GAS EXPLOSION, INDIANAPOLIS.

latter look like the probable cause, although as far as we know, the engineer had from previous experience no reason for supposing that the usual air supply was not sufficient to burn the volume of gas which would flow at the full pressure available under the boilers. The full pressure is supposed to be used when required. The gas inspector had daily visited the station to take readings under the same conditions as when the explosion took place. The explosion occurred on Friday at 4 p. m., and the entire plant was started Monday at 11 a. m. The boilers were reset and piping and building repaired in that time. It was wonderfully quick work, as the night of the explosion it looked as if a week would not be sufficient to repair the damage.

\* \* \*

#### Suggestions on Live Subjects.

BY GEORGE H. LEONARD, NEWTON & BOSTON STREET RAILWAY.

In relation to the much discussed question of high and low speed engines, I think that 300 horse-power, or above, should be slow speed compound condensing. Sizes between 300 and 100 horse-power should be high-speed compound condensing, and those under 100 horse-power, simple high speed. All should be direct connected, as I



do not believe in rope or belt drive when it can be avoided. The great objection to direct connected generators has been the idea that short circuits are more liable to break the engine, but the safety devices of to-day do away with all danger. I do not think a slow-speed engine smaller than 150 horse-power can be used to advantage in a railway power station. Plants of less than 1,000 horse-power can not afford to use mechanical stokers, but I think that they are an advantage for plants of 1000-horse-power and over. Water tube boilers are better for use with water that scales than return flue, if you have a spare boiler, as every station should have. I do not think the return flue boiler is "in it" to-day. The best place to feed a boiler is in the top of the shell, running the pipe the length of the boiler inside. I write the above because I would like to get the views of other street railway engineers on the same subjects. Among other things I would like to hear the best way to heat feed water when condensing engines are used, as this is an important factor in some power plants.

\* \* \*

#### Storage Batteries for Central Station Work, at Merrill, Wis.

BY E. S. KING, SECRETARY MERRILL RAILWAY & LIGHTING COMPANY.

We have placed a contract with Electric Storage Battery Company, of Philadelphia, manufacturer of the Chloride Accumulator, for 240 cells, type "F," 11 plates to each cell, with maximum capacity of 100 amperes per element, for four hours discharge, normal capacity, 50 amperes discharge of ten hours duration. Our object in making this purchase is to equalize the voltage upon our trolley line during the day, and assist us in furnishing electric lights during the period of heavy load at night.

We operate 1,000 16-candle-power lights, and one railway generator of 50 kilowatt capacity, with water power, using two turbine wheels of about equal capacity, one for lighting, the other for the railway generator. We have ascertained that the railway generator would not require, for operation of the two cars we regularly run over our track of a little less than two miles, an average of more than 15 horse-power, but as now operated, the load changes from "no load" to 50 or 60 horse-power quite frequently, and causes the voltage to vary from 300 to 520, according as the load is heavy or light. This prevents us giving satisfactory motor service, and we consider it detrimental to our car motors. It also prevents us connecting the two water wheels during the period when the electric lighting load is heaviest, and getting the benefit of the surplus capacity of the wheel operating the street railway generator, which is greatly needed to assist the electric light wheel, especially when the water is below the ordinary stage. The changes of load on the street railway affecting the speed of the wheel enough to make the difference in voltage cited above, would affect the speed of both wheels when connected, although to less extent.

Our plan is to connect the 240 cells, in series, to the

generator during the day, and operate the same under a constant load, a little greater than the average load required on trolley, thereby keeping the battery fully charged; and at night, when help is needed for electric lighting, the battery to be disconnected from generator and connected with the three wire lighting system, two groups, of sixty cells each, on each side, aiding the lighting dynamos, to the extent of about 800 lights, for the period of heavy load.

We feel confident that the battery will have such an equalizing effect upon the pressure to be maintained on the electric light wires, that if necessary, the wheel operating the railway generator can be then connected with the one operating the light dynamos, without detrimental effect, giving the surplus power of that wheel which we are now unable to use. In addition to these benefits, we will make considerable saving in another way. We hire steam power, at the west end of our city, to operate 500 16-candle-power lights, in addition to the other lights mentioned, for the reason that the water power is not sufficient when water is at a low stage, and the further reason that the center of this lighting is at a considerable distance from the water power, and with our system the loss in distribution is considerable, and the difficulty of equalizing pressure great. With the increased power derived from this battery, and having it located at our car house, within one-fourth of a mile of the center of the west end lighting, we will be enabled to discontinue the use of this steam power, and furnish lighting at that end of the city from our water power, with the aid of the battery, and give a perfectly satisfactory light. In fact, we have every reason to believe that lights operated in connection with a storage battery, in this manner, will be as near perfect as electric lighting can possibly be. Operating in this way we will save the charges now paid for steam power, and the other expense incurred in this station. The advantages are constant load on generator; equal voltage on trolley, which allows us to give motor service therefrom; obtaining all of the power of our two water wheels when needed; a more equal voltage on our lighting mains; an increased capacity for lighting, which can be added to from time to time by purchase of new batteries; saving the expense now incurred at west end for power; making it possible to run the street railway for several hours from battery alone, when necessary that generator or wheel be stopped. In fact, it may be to our interest to run the street railway regularly for a part of each day from battery alone, saving some in labor charges.

It is guaranteed that the cost of maintenance of battery shall not exceed 10 per cent of the list price of same, for a period of ten years, with the assurance that in all probability it will cost much less. Special guarantees were given us by the Electric Storage Company, as the installation will probably be the first in this country applied to railway work. In order to properly operate our lights we had to adopt something of this kind, or build a steam plant, which as we are situated we could not do, in connection with the water power we now use,

and we would lose all the advantage derived from cheap power if the latter plan was adopted. The cost of battery is much less (60 per cent) than the steam plant necessary for our use would have been, and the operating expense, including maintenance of water power and storage less than \$3,800 per year, while steam power would cost us probably \$10,000 per year.

\* \* \*

#### Big Stratton Separators for Philadelphia.

Six Stratton Separators, of the size shown in the engraving, are being put in the Philadelphia Traction

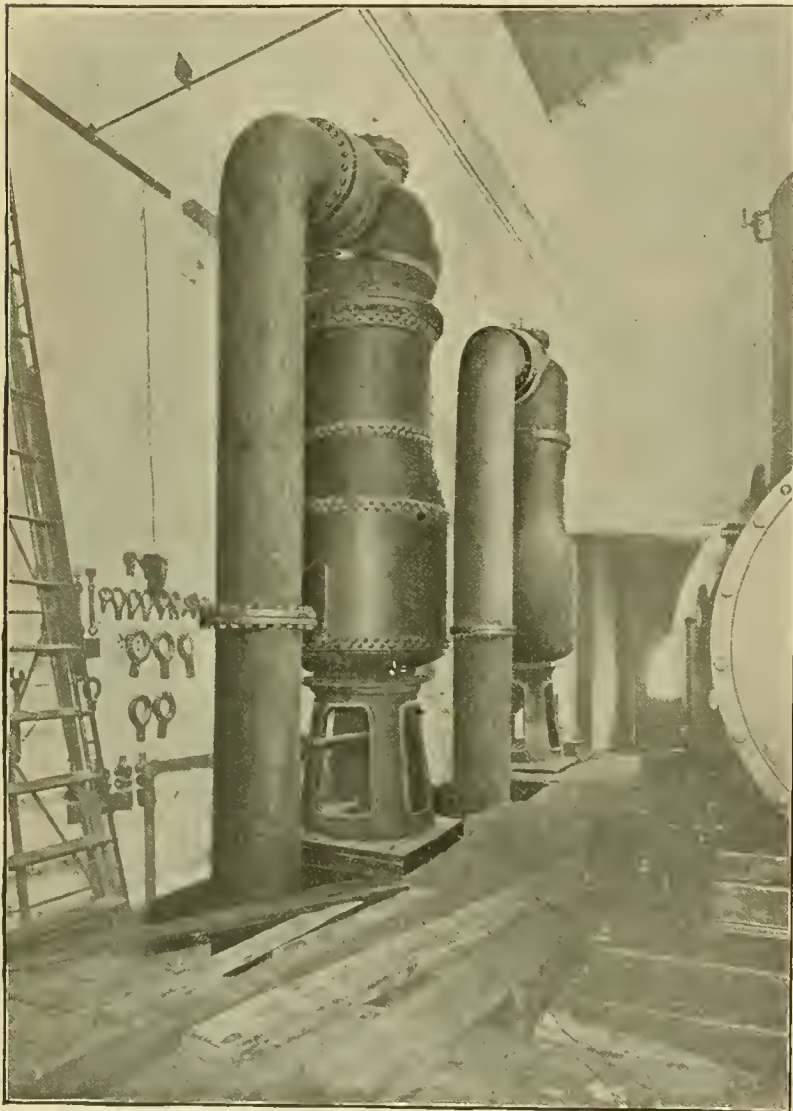

BIG STRATTON SEPARATORS FOR PHILADELPHIA

Company's plant at Thirteenth and Mount Vernon streets. The large separators and feed water heaters of the Goubert Manufacturing Company are famous for their size and number, but this latest installation exceeds both in individual size and aggregate number all previous ones made by this company. Two of the separators in this station are 18-inch, two 16-inch and two 8-inch.

One of the 18-inch separators is in the foreground of the engraving. The principle of this separator is that of imparting a rotative motion to the steam, so that all the heavy liquid particles acquire a centrifugal force and are projected to the outside of the current. The apparatus consists of a vertical cylinder with an internal central pipe extending from the top downward, for about half the cylinder's height, so that there is an annular space between the two. The steam is admitted near the top of the annular space and leaves the separator from the top of the inner pipe. The current of steam on entering is deflected by a curved partition, and is thrown so that it whirls around the cylinder while descending the annular space and the water particles are thrown against the outer walls of the separator. A thin sheet of water is continually running down the inside of the outer shell. The steam, now in a dry condition, passes up the inner tube and on to the engine. The lower part of the separator is enlarged to form a receiver for the water that falls, and is provided with a drip pipe and with a glass gauge for showing the level of the water in the separator. The Goubert Manufacturing Company has also supplied these separators to the amount of 12,000 horse-power to the new plant of the Philadelphia Traction Company.

#### ANOTHER SAN FRANCISCO LINE ABSORBED.

The Market Street Railway Company, San Francisco, has bought the Metropolitan Railway. The capital stock is \$1,000,000; first mortgage bonds authorized, \$250,000, of which \$200,000 have been issued. There is also a slight floating indebtedness. The road has been put under the management of the Market Street Company by the appointment of M. D. Stein, as manager, and the election of N. T. Smith, treasurer, and J. L. Willcutt, secretary. It is a double track road, five miles long, and is the second electric railroad put in operation in the city, having been running since October 20, 1892, the first being the San Francisco & San Mateo Railway, which was opened for travel April 26, 1892.

The Metropolitan is a first-class road, and well equipped in every respect. It runs from the junction of Market, Powell and Eddy streets, through the central portion of the city in a general westerly direction to the Stanyan street entrance to Golden Gate Park, with a branch from the junction of Page and Clayton streets to a southerly entrance to the park at Ninth avenue. The purchase of this company makes twelve companies in the Market street system.

H. N. HURT, superintendent of the Atlanta Consolidated Street Railway, has resigned.

## EN ROUTE TO ATLANTA.

The visitor to the convention will in all probabilities pass the first twelve hours of his pilgrimage in sleep. And let the writer add it is better so, since the day following will need a rested body and mind to enjoy the experiences and scenery in store. The comforts of the elegant sleeping cars of the Monon and Big Four routes will thus be appreciated from Chicago to Cincinnati.

On arriving at the Queen City, all the separate parties may be gathered together for the daylight trip through the most beautiful of southern scenery, over the Queen & Crescent's magnificent and expensive roadbed, with vestibuled cars to match.

On crossing the sluggish Ohio, the traveler finds himself almost instantly in a new realm. The aspect of the country changes somewhat, but the principal change is in the people and scenes along the line. It is old Kentucky. Speeding through the magnificent rolling blue grass country, the traveler soon finds himself in the foothills of the Cumberland Mountains, and over the rivers and through the tunnels toward the highlands of Tennessee. All along the line the magnificent vistas are opened up. Crossing the Kentucky River on the High Bridge and the north and the south forks of the Cumberland, glimpses of the loveliest nooks almost impel the tourist to stop off at the next station and plunge into the woods with rod and gun as his only companions. To the left of the track now comes the rounded, wooded domes of King's Mountain, Science Hill, and others of the lower



SCENE FROM THE TRAIN.

hills of the Cumberlands, which reach their greatest altitude in Missionary Ridge and Lookout Mountain.

At the Emory Gap history begins to assert itself, and the grounds and woods bring up memories of the late war when Emory Gap was the pathway of contending armies. Delicious trout streams and tall pine trees and thickly wooded hills appeal to the aesthete and the sportsman, while the pure, clear air is a balm to lungs filled with city smoke. To the right of the train is Walden's ridge, which stretches down to Chattanooga with occasional spurs of local fame. To the right of the train may be seen coal and coke industries and iron furnaces in full blast. It is now about dusk, and the sun shining into the clouds above Walden's ridge give an eerie glamour to the scene of peace and quietness. At one point a deserted

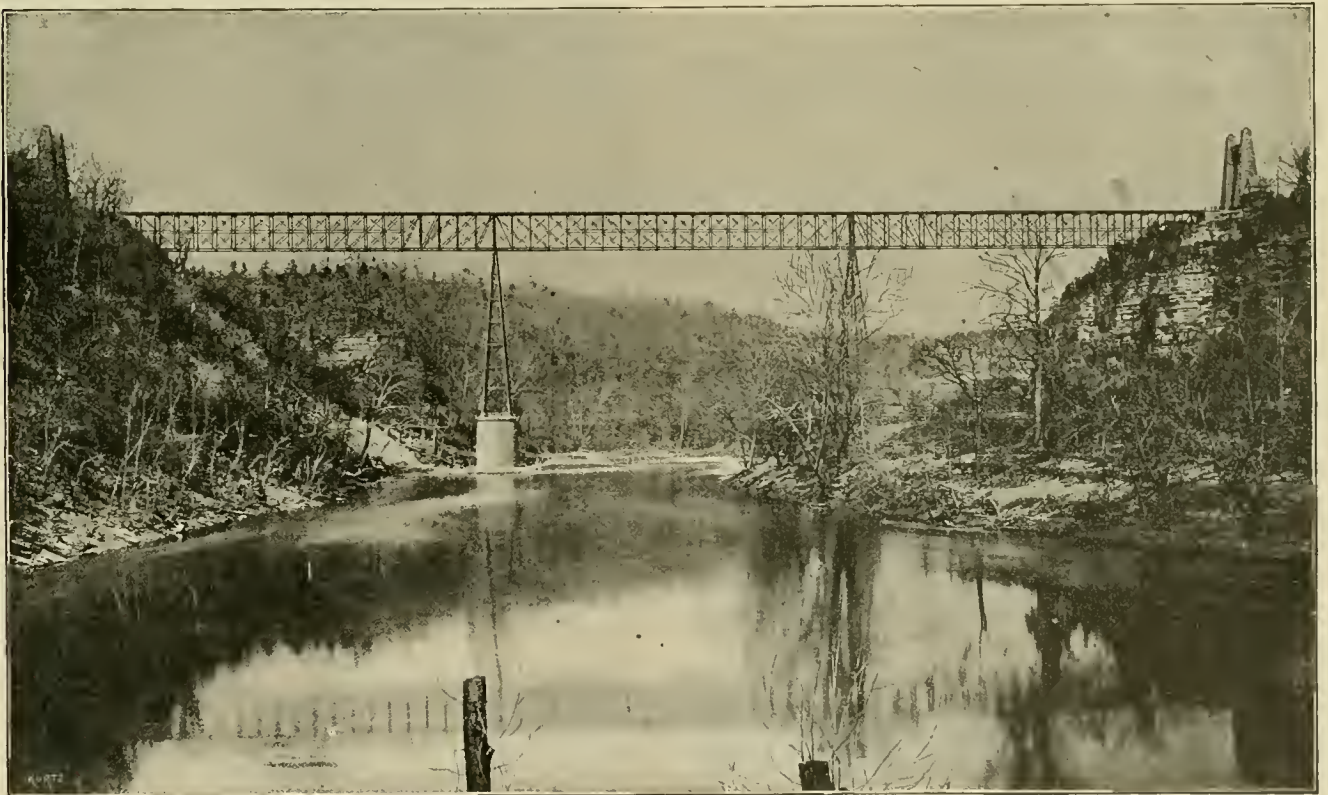

HIGH BRIDGE OVER THE KENTUCKY RIVER.

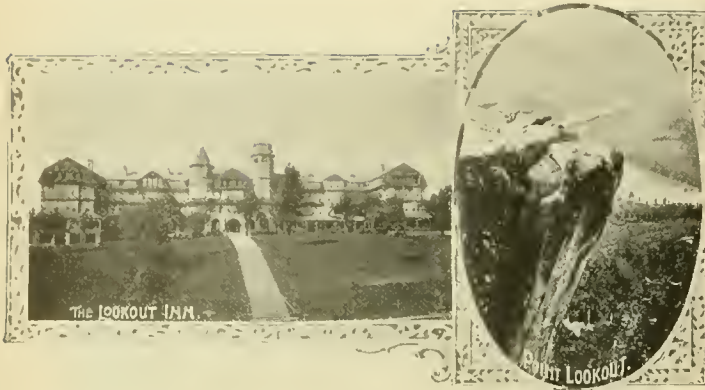

boom town may be seen with a street railway road bed overgrown with grass and weeds.

Night begins to fall upon the scene, and Chattanooga is reached in darkness. The train plunges on, and by the next morning the delegates will be greeted by the local committee in Atlanta.

On the return trip, a stop will be made at Chattanooga to enable the visitors to view that beautiful town, famous for its historic interest, its natural scenery and its commercial importance. The receiver and manager of the Chattanooga Electric Railway, S. W. Devine, and the genial general superintendent, W. S. McCall, will show the city and its environs to the visitors. The Chattanooga Electric Railway was organized in 1888. It has 32 miles of track and 32 motor cars and 5 trailers. Stephenson cars are in the majority, and Edison electrical equipment is used throughout. Beck, and Armington & Sims engines of 550-horse-power make the power equipment, in company with the Taylor and the Walsh & Weidner boilers of 600-horse-hower.

One of the principal lines runs to Lookout Mountain and another along Missionary Ridge. The cars and the incline carry the tourist to the top of Lookout Mountain, where a beautiful view may be had of all the varied scenery.

It will be worth the trip to the summit to gain the general view and the particular points of historic interest so vividly portrayed in the histories.



LOOKOUT MOUNTAIN.

## NEW SUPERINTENDENT AT SACRAMENTO.

The Central Electric Railway of Sacramento, owned by the Electric Power and Light Company, is a center of interest now, because engaged in a plan to transmit its power, from a water power at Folsom, 20 miles from Sacramento. T. A. W. Shock is the new superintendent, and his work on the transmission plant will afford him great opportunities.

Mr. Shock is a graduate of the U. S. Naval Academy at Annapolis. For several years he was connected with various electrical concerns, and finally became engineer for the General Electric Company, at Portland, Ore. Here he had charge of railway construction and power



VALLEY OF THE KENTUCKY RIVER.

transmission, so that by education and experience, he is fitted for the recently assumed position. Fuel for running the steam plant at present costs \$6 per ton at Sacramento. Only a part of the transmitted power will be used for the railway. The balance will be taken by lighting, stationary motors and heating. Of stationary motors there are already 3,000 horse-power in this climate, while electric heating is especially popular in this climate, because it does away with the needless heavy fires for cooking and for morning and evening heating.

A HOLY howl arises from Westerly, R. I., where the electric cars have so affected the river traffic that the largest of two steamers which have daily plied on the Pawcatuck for the past two weeks will be taken off the route.

THE XIIIth ANNUAL CONVENTION OF THE AMERICAN STREET RAILWAY ASSOCIATION.



EXPOSITION BUILDING, WHERE CONVENTION WILL BE HELD.

On Wednesday, October 17, 1894, President Henry C. Payne, of Milwaukee, will call to order the first session of the thirteenth annual convention of the American Street Railway Association, in Machinery Hall of the Piedmont Exposition, Atlanta, Ga.

The occasion will be noteworthy, from the fact that the city of Atlanta is the smallest that has ever entertained the association, and that this is the farthest south that the association has gone to hold its sessions, but it is, without the least tremor or apprehension on the part of any one, that the street railway men of the country place their convention and annual good time into the hands of the brightest, most modern and most hospitable of southern cities.

The association will be warmly welcomed by the citizens of Atlanta, and at no time in the history of the organization has the general public taken so warm an interest in the affair.

The following table shows the history of the association at a glance:

PLACE.	PRESIDENT.	YEAR.	NUMBER MEMBERS.**
1 Boston .....	Hon. Moody Merrill* .....	1882	24
2 Chicago .....	H. H. Littell.....	1883	62
3 New York .....	Wm. H. Hazard .....	1884	102
4 St. Louis .....	Calvin A. Richards† .....	1885	123
5 Cincinnati .....	Julius Walsh .....	1886	140
6 Philadelphia .....	Thos. W. Ackley†.....	1887	152
7 Washington .....	Chas. B. Holmes.....	1888	157
8 Minneapolis .....	Geo. B. Kerper .....	1889	161
9 Buffalo.....	Thos. Lowry.....	1890	173
10 Pittsburg.....	Henry M. Watson .....	1891	184
11 Cleveland .....	John G. Holmes.....	1892	204
12 Milwaukee .....	D. F. Longstreet.....	1893	197

\* Chairman of the organization. † Deceased. \*\* Companies only.

It may be stated that the last year's loss of membership is entirely due to the consolidations effected during the year 1893, in New York, New Jersey, Pennsylvania and Ohio, particularly.

For the session of 1894, the following is the program, subject to the changes noticed later:

**CAN THE T RAIL BE SATISFACTORILY USED IN PAVED STREETS?**

Joel Hurt, president Atlanta Consolidated Street Railway, Atlanta, Ga.; S. Hendrie, manager Wyandotte & Detroit River Railway, Detroit, Mich.; H. J. Crowley, engineer Atlanta Consolidated Street Railway, Atlanta, Ga.

**CITY AND SUBURBAN ELECTRIC RAILWAYS.**

E. C. Foster, superintendent Lynn & Boston Railroad, Boston, Mass.

**MAIL, EXPRESS AND FREIGHT SERVICE ON STREET RAILWAYS.**

R. McCulloch, electrical engineer, Citizens' Railway, St. Louis.

**BEST METHOD OF TREATING ACCIDENTS AND COMPLAINTS.**

John B. Parsons, general manager West Chicago Street Railroad Company, Chicago.

**STREET CAR WHEELS AND AXLES.**

D. S. Cook, electrical engineer, Trenton Passenger Railway Company, Trenton, N. J.

**TRANSFER AND COMMUTATION.**

Rodney Curtis, president Denver Tramways Company, Denver, Col.

**TRAIL CONSTRUCTION OF THE TERRE HAUTE ELECTRIC RAILWAY COMPANY, TERRE HAUTE, IND.**

M. F. Burke, superintendent Terre Haute Street Railway Company Terre Haute, Ind.

**A STANDARD FORM FOR ACCOUNTS FOR STREET RAILWAYS.**

H. I. Bettis, New York

The report on "street car wheels and axles" will be presented by another person, as Mr. Cook has been ill for some time and has resigned his position. President Rodney Curtis will be detained by business at Denver, and his thesis will be read by another.

President Russell B. Harrison, of the Terre Haute Electric Railway, will present the paper on the T rail construction at Terre Haute.

The subjects are all fresh and interesting and will have deserved attention.

The local committee has arranged, subject to change, the following plan of entertainment:

WEDNESDAY EVENING.—A reception at the Capital City Club. The club will extend its courtesies to all the gentlemen in attendance.



HENRY C. PAYNE, PRESIDENT.



WILLIAM J. RICHARDSON, SECRETARY.



T. H. MCLEAN.



J. R. CHAPMAN.



E. S. GOODRICH.



W. Y. SOPER.



LEWIS PERRINE.

THURSDAY EVENING.—The banquet, probably at the Capital City Club; if not there, at the Aragon Hotel.

FRIDAY.—The visitors will be treated to a typical Georgia barbeque, at Stone Mountain. The latter is the piece de resistance, and nothing the committee could afford will give more pleasure.

The ladies will be taken in charge and personally conducted to the salient points of interest about the city.

#### THE OFFICERS AND COMMITTEES.

The officers and executive committee of the American Association for 1893-94 are:

Henry C. Payne, president, Milwaukee, Wis.  
 Wm. J. Richardson, secretary and treasurer, Brooklyn, N. Y.  
 W. J. Stephenson, first vice-president, Washington D. C.  
 J. R. Chapman, second vice-president, Chicago.  
 Lewis Perrine, third vice-president, Trenton, N. J.  
 Executive committee: D. F. Longstreet, Denver, Col; T. H.

McLean, Indianapolis, Ind; Ed. Whittacre, W. Y. Soper, Ottawa, Ont., and E. S. Goodrich, Hartford, Conn.

It is with great regret that the news of the death of Vice-President Stephenson has been received.

The local committee consists of the following Atlanta gentlemen, named under their respective sub-committees:

HOTEL.—Wm. W. Kingston, Walter M. Kelley, S. W. Trawick, E. P. Thomas, A. F. Giles.

EXHIBITS.—N. W. L. Brown, Walter M. Kelley, Dana R. Bullen, W. W. Kingston.

TRANSPORTATION.—W. M. Kelley, J. H. Allen.

ENTERTAINMENT.—R. J. Lowry, J. Carroll Payne, T. K. Glenn, W. W. Kingston, Henry Inman, J. W. English, Jr., Livingston Mims, H. N. Hurt.

BANQUET.—H. E. W. Palmer, J. Carroll Payne, E. Woodruff, R. J. Lowry, Henry Jackson, T. B. Felder, Jr., Livingston Mims.

EXCURSION.—W. M. Kelley, E. Woodruff, H. N. Hurt.

FINANCE.—E. Woodruff, R. J. Lowry, T. B. Felder, Jr., Jas. W. English, Jr., W. C. Sanders

## ATLANTA, GEORGIA.

Gate City of the Southland's Realm,—Of Commerce, Art and Politics, the Helm.—Homes of Her Men—  
Growth of Her Chivalry—And all the Visitor Will Care to See.—The Healthful Heights—The  
Works of Public Use—And all the Lessons Which from These Deduce—Yet  
Should the Doubter Say, "Can these Things Be?"—Our Only  
Answer Is, "To Go and See."

It is the stern decree of the shadowy and uncertain Fate that moulds the destinies of cities that where Fate wills must the city build. So was it with Atlanta, whose founders fifty years ago treading the cowpath, now Peach-tree street, little thought that from beneath their footsteps would spring marts of trade and palaces

Why do the pampered settlements with every opportunity for growth dwindle and die in spite of the heroic

to the Atlantic and west to Gulf, and, where the waters divide, there is the division station of commerce. The elevation of the city at the tracks of the Union depot is reckoned at 1,050, although several points in the city are from 50 to 100 feet higher. With the exception of Denver it is rated as having the greatest elevation of any city of approximate size in the United States

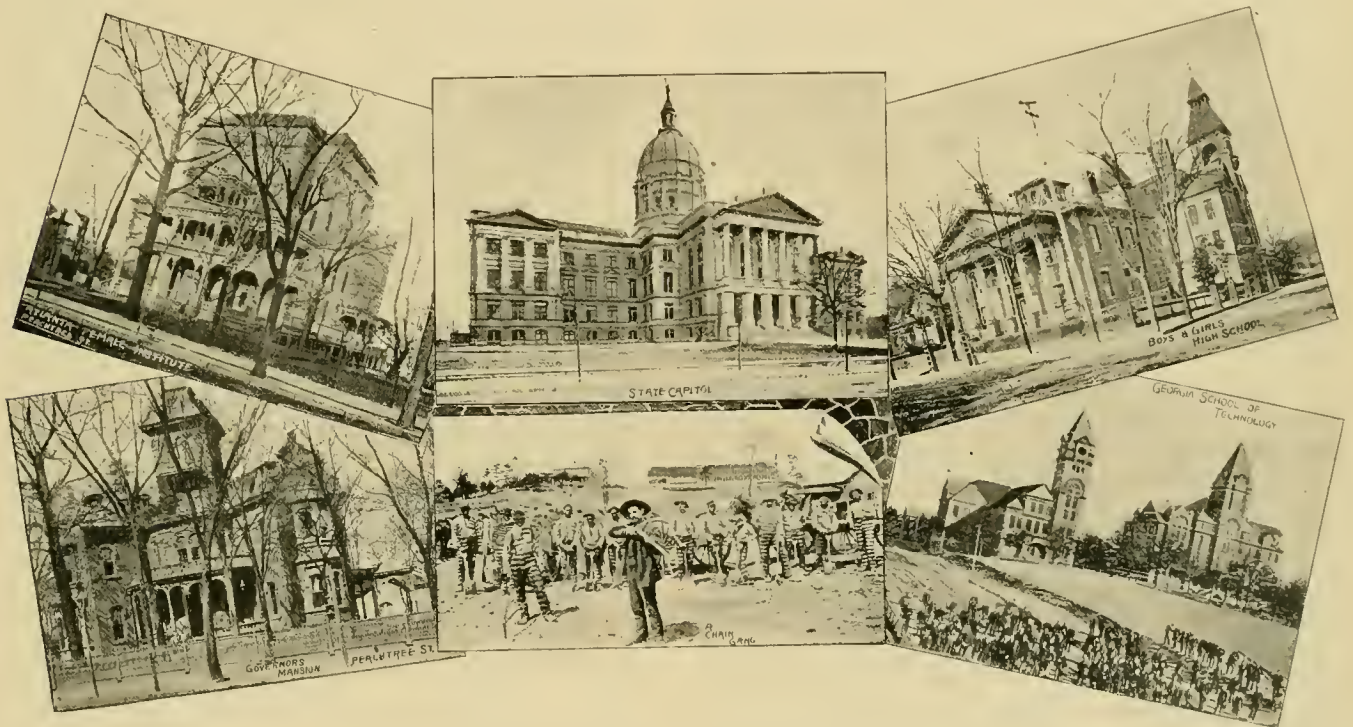

efforts of their founders? Why has every large city moved its base of development from the spot designated by reasoning and learned men and settled along the cow-path or in the marsh? We do not, nor do the real estate men, know. Atlanta is no exception to this vagary of growth, for it resolutely moved away from Decatur to grow to lusty strength, while Decatur is now satisfied to be a suburb of it. The city of Atlanta is situated in latitude  $33^{\circ} 45' 19''$  north and in longitude  $84^{\circ} 23' 10''$  west of Greenwich. Located on a spur of the Blue Ridge mountains where the mighty procession of the Alleghenies converge and radiate into ridges of moderate height, suitable for agriculture or residence, Atlanta has reared itself to become the gateway city of the south, the eye and ear and nerve center of the empire of the southeast. It is seven miles northeast of the Chattahoochee river, and on the southernmost crest of the Chattahoochee ridge, which divides the waters which flows east

With this great natural advantage, coupled with its central location, it is not to be wondered at that Atlanta has become what it is.

The great transportation systems centering at Atlanta are: The Richmond & Danville (Piedmont Air Line), the Georgia, the Central, and the Georgia, Carolina & Northern connect her with the Middle Northern, the Northern, and the New England states; the Western & Atlantic, the East Tennessee, Virginia & Georgia (Southern Railway) give passage to the Allegheny, the Rocky Mountain, and great lakes region; the Central, the Atlanta & West Point, the Atlanta & Florida, and the Southern reach the South Atlantic and Gulf states, while the Georgia Pacific and the Atlanta & West Point lead to the great Transcontinental systems. As far back as 1845 John C. Calhoun predicted Atlanta would be the distributing point of the southeast.

In 1836 one family populated Atlanta, and ran the

town at its own sweet will. It was the Ivy family. O poetic chance, has not the Ivy spread, and driven out the Cherokee Indian, and luxuriated into a noble plant! In 1836 the Western & Atlantic Railroad made the Ivy homestead its terminus, and the station was promptly called Terminus. In 1842 Terminus had six houses, and began to assume metropolitan airs.

In 1843 Terminus applied for a charter and incorporated as Marthasville. The village began to grow, and in 1844 the 200 citizens began to call the place Atlanta, which was ratified by legislature in 1847. In 1845 the first newspaper was started and named the Luminary. It shone six months and went into eclipse.

Atlanta passed its early youth after the usual fashion of growing towns everywhere. Whisky, riot and ruffianism were rampant by periods, and good government achieved in the interim. In 1850 the population of Atlanta was 3,000, with fifty stores, all of which sold liquor. Then a "moral" party gained the ascendancy, and a happy occasion it was for the metropolis. Other lines of railroad began to come into the city, and the church, the bank, and the newspaper assumed being. Property in the city at that time was not sold by the front foot but by the acre.

The original street was Peachtree, and was laid out by the useful if humble bovines that tramped down hill and back every day, to the present site of the Union depot, where a spring furnished water for the village cows.

Every successive year was filled with increase in business, and a rapidly developing population drew more desirable citizens to the place. It was thus that out of a country village a city developed. Nothing in history of American cities, nay, of all the cities of the world, is so close a parallel to the city of Chicago as Atlanta. As late as 1850, it is said that 100 acres, now the site of the magnificent capitol, were offered for \$1,000, and the misguided party of the second part refused to close the transaction because the price was too high! Land on Peachtree street, half a mile from town, was quoted at \$10 an acre. It now sells for as high as \$500 a front foot.

The city was lighted by gas in 1855, and was one of the first in the south to adopt that method of illumination. George Smith of Chicago, established the first bank in 1850 and capitalized it at \$300,000, and in the same year the first extensive fire occurred in Alabama street.

The panic of 1857, which had so disastrous an effect on the country at large, disturbed Atlanta but little, and the period up to 1861 was a history of commercial development unparalleled in the south.

A table of population of the period from the foundation to 1860 reads as follows:

In 1836	-	-	-	3
1844	-	-	-	200
1855	-	-	-	6,025
1860	-	-	-	12,000

The doubling of population in five years during heated

political times and in the midst of a panic is little less than miraculous. So much for the first period.

From 1860 to 1864 even with the departure of the leading citizens caused by the claims of the war, Atlanta steadily gained in its population and in 1864 no less than 20,000 people called Atlanta their home.

The events covering the period from 1860 to 1864 are in the books and it is unnecessary to relate them here. Throughout this time Atlanta was a center in this as in other cases. In September of the bloody year of 1864 the cruel necessities of war made Atlanta a heap of ruins. The business portion was almost totally destroyed, and out of three or four thousand houses scarce three hundred remained. Out of the horrors of war the refugees returned however, and with brave hearts again undertook the raising of a city. With the old time energy and pluck, with almost, unsurmountable obstacles, the survivors rebuilt their shattered homes and from chaos brought order and decency. Of this era no commentary need be other than to say that men from New England and Texas, Illinois and Alabama, New York and Mississippi now stand shoulder to shoulder, with but one watchword "Atlanta and the commonweal." One of the most enthusiastic Atlantans that the writer met was a Philadelphian of pronounced quaker ancestry. Atlanta's *genius loci* is overpowering. To stay in the city a day means respect, to tarry a week abundant enthusiasm and a years residence makes one an Atlantan for life.

Like the fabled hero, Atlanta was only the stronger for the fall. The new era began by a revival of trade and business, and if there ever was an old Atlanta there is none now.

Bounding forward the city gathered its forces, and as figures can't lie and our enthusiastic pen might, it is better to refer to statistics. In 1865 there were, say 10,000 souls in the city.

In 1870	-	-	-	21,788
1875	-	-	-	30,869
1880	-	-	-	37,409
1883	-	-	-	49,517
1884	-	-	-	53,812
1888	-	-	-	88,936
1891	-	-	-	92,460
1894	-	-	-	110,001

AS SHE IS.

Let there be three things that make a city pleasant to live, desirable to trade in, and as needs must be, and we die anywhere, to die in. These three are climate, resources of material wealth and culture—yea, and a fourth, namely, means of intramural transportation. It is our humble opinion that Atlanta is possessed of all these to a high degree.

As for climate, Mr. Weary Walker says "you can't eat it but it's pleasant to have 'round."

The altitude of the city, 1,050 feet above tide with magnificent natural drainage, is very conducive to the non-existence of *bacillus tuberculosis* and *bacillus*



typhoidis. The mean temperature throughout the year is given by the signal service as follows:

MONTH.	Temperature.				Dew Point—Mean.	Precipitation in inches Total amount.	Prevailing Direction.
	Monthly, Mean.	Maximum.	Minimum.	Absolute Range.			
January . . .	36.0	65	8	57	25	3.02	N W
February . . .	46.2	70	30	40	37	5.45	N W
March . . . .	51.4	79	18	61	35	2.43	N W
April . . . . .	64.2	84	39	45	48	2.48	S W
May . . . . .	67.2	90	47	43	53	4.46	N W
June . . . . .	74.2	88	57	31	63	4.65	N E
July . . . . .	80.6	96	66	30	67	2.13	N W
August . . . .	77.0	91	62	29	66	4.07	N E
September . .	73.0	90	55	35	62	3.06	S E
October . . . .	61.6	84	34	50	48	0.39	N W
November . . .	50.8	74	21	53	39	1.11	N E
December . . .	46.6	67	21	46	36	3.18	N W
Sums . . . . .	728.8	Max	Min.	520	579	36.43	
Means . . . . .	60.7	96	8	43	48	3.04	M W

For fourteen Augusts the average temperature in Atlanta was 78.8, while Augusta, Ga., registered 80; Savannah, 79.8; New Orleans, 81.5, and Vicksburg, 80.7. The annual rain fall is 50 inches. Fogs are unknown, and cloudy days few, with the largest number during July and August. The nights are always fairly cool.

The disease peculiar to the south, yellow fever, never becomes epidemic in Atlanta. A few cases escaping the close inspection of the health commission have been known from time to time, but no instance is on record of the disease spreading to another individual.

The total mortality for 1893 was 1,920, of which the colored race furnished 1,107, and 971 cases were over five years of age.

### STREETS.

The ancient cow path, out of which grew Peachtree street, set the fashion of the other older streets of Atlanta for crookedness. By reference to a map of the down town streets, it may be seen how they twist, turn, and from time to time disappear in some other thoroughfare of different name and destination.

Peachtree street runs in a northerly direction, and above Ellis is the great residential street of the south. The Capital City Club, the governor's mansion, the Bell house, an ante-bellum relic, are in this street, which is traversed by the Peachtree and the Ponce de Leon cars to the plant and to Piedmont Park.

Whitehall street has a southwest tendency from the railroad tracks. It is the great retail trade street.

Alabama runs east and west from Whitehall. It is a wholesale and banking center; street cars.

Decatur street starts at Peachtree and parallels the Georgia Railroad tracks. It is a market street; street cars.

Marietta begins in Peachtree and goes west. It is a manufacturing street; street cars. At its junction with

Broad street is the post-office, custom house, old Capitol and Opera House.

Broad street intersects Marietta, north and south. It is a large business street. At or near this corner all Consolidated and Traction cars pass.

Pryor is a wholesale street running north and south from Union depot. Wall street occupies both sides of the railroads. It bounds the Kimball, Union depot and wholesale houses and warerooms.

Washington street and Capitol avenue bound the new Capitol. They are the elegant streets of the South Side and contain handsome residences. From the Capitol a fine view may be had of Stone Mountain, Kenesaw, Lost Mountain, and the city. It will repay the trouble. Street cars.

### L. P. GRANT PARK.

Early in 1883, Col. L. P. Grant began to forecast the possibilities of Atlanta's greatness, and generously gave to the city 100 acres of land on the southeast edge of the city. In the spring of 1888, the donee bought a 45-acre tract north of the first plat, and Grant Park embalmed the memory of the founder in the beautiful spot to which his name is given. A topographical map was drawn up, and work began on the construction of roadways, lakes, gardens and pavilions. There are now seven miles of graded and macadamized driveway and six miles of shady walks. The landscape gardening has been well done, and Atlantans are to be congratulated upon the good use made of appropriations for the purpose—in all \$70,000. The park roads are named after Georgia cities, and fountains, flowers and easy lounging places make it a popular resort of the city's population. There are two large pavilions, a fine collection of native and exotic trees, flowers and shrubs, and a well-selected "zoo" of considerable size. Statues adorn appropriate nooks, and two lakes furnish aquatic amusement.

The confederate fort "Walker," a defensive fortification built in 1864, has been restored and remounted to its original grim interest. The children of the city have given a large and handsomely wrinkled elephant to the collection of animals. The park management has also stationed here the cyclorama known as the Battle of Atlanta, of which the original cost was \$40,000. It occupies a building 50 feet in diameter and 20 feet high, and gives the visitor a truthful commentary on Atlanta's most romantic period. Grant Park may be reached by the Fair street, or the Peachtree, Pryor and Georgia avenue electric cars of the Consolidated. Just north of Grant Park is Little Switzerland, an ideal ground, where cool streams flow for and breezes blow upon the white population only, as it is a private property. Refreshments and games add to the attractions here.

### PIEDMONT PARK.

Just outside of the city limits lies 189 acres of finely diversified land, owned by the Piedmont Exposition Company, but leased to the Cotton States International Exposition, which will open September, '95.

Spacious buildings were erected by the Piedmont Company, all of which, except the main building and Machin-

ery Hall, have been torn down to make way for eight more elegant structures of new design and permanent. One of the new buildings will be devoted to electricity. A fine mile track, a grand stand, club houses and stables are also here, for the use of the Gentlemen's Driving Club.

The Machinery Hall, which is the home of the association, may be seen in our engraving. It is 392 feet east and west, and 74 feet north and south. At the northeast a space has been boarded off 73 feet square, with a rostrum at the north. Here the sessions will be held. A Hamilton-Corliss engine of 250 horse-power stands at the center of the room, but will not be used. Power will be furnished from the plant of the Street Railway Company, which is half a mile distant. The Southern Railroad has a track within gang plank reach of the porch of the building, and packages to the weight of ten tons have been handled over it on rollers with safety and dispatch. The belt road does all the switching.

The Boulevard and the Peachtree lines of the Consolidated go to the park entrances, a distance of two and a half miles from the city's center. Every courtesy will be shown exhibitors, and, as the building has no galleries or dark corners, all space is desirable.

#### PONCE DE LEON.

The fabled spring of eternal youth, for which Ponce De Leon, the Spanish explorer sought so long and hopelessly, is on the nine mile circle, and the Ponce De Leon routes of the consolidated. The street railway company has here a boat house, and a commodious bath house, at either side of a little lake about 500 yards square. It has been a source of considerable profit and is nearly always the scene of festivities during the summer. The waters possess curative properties and are especially efficacious in kidney complaint. Colored people are allowed in the little park surrounding it, only as servants. Opposite the springs is a beautiful grove and picnic ground, controlled by stockholders of the Consolidated Electric Railway Company, which is also the occasion of considerable traffic. It is stated by the superintendent, however, that travel to the resorts, as well as to the business portion of the town has been considerably reduced by the hard times and the general financial stringency. A line to East Lake, an artificial body of water on the line of the Traction Company, is well patronized during the warm season, by bathers. The most desirable suburban spot in Atlanta is Inman park, named after the gentleman whose portrait appears elsewhere. The Inman park (Consolidated) cars run frequently to the addition, and a beautifully paved drive makes it one of the finest carriage roads in the city. The elegant residences of this fashionable neighborhood may be surmised from the engravings presented. It will become at no late date one of the best real estate points in the city.

#### FORT M'PIERSON

is an United States army post, authorized in 1885. The reservation occupies 250 acres, and has barracks, hospital, stables, and other paraphernalia of army life. Several

companies of infantry are stationed here, and on account of the healthfulness of the climate, coast defense troops are brought here during the summer. One company of Indians is stationed at the fort. The reservation is reached by the Traction Company's cars and a beautiful drive.

The Collins Park & Belt Street Railway goes through a section of country which was well tramped over during the late war by the armies of both sides. Along the right of way may be seen the remains of ancient defenses thrown up from the soil, and now covered with the green sod and bright flowers of summer; a contrast to the blood and carnage of former days.

On the Decatur line of the Consolidated is something of interest to the Northerner who visits the cotton belt for the first time, namely, patches of that shrub whose bright yellow flowers will have become bursting pods of commercial importance by the time the street railway men arrive, although late cotton may be seen "in the boll."

The nine mile circle, which passes the Consolidated plant, also skirts the cotton fields, and several grand old homesteads of men who, with the times they graced, have gone into history.

On Peachtree street, just north of the Aragon Hotel, stands one of the features of which Atlanta is justly proud. It is the home of the Capital City Club, whose members are the first citizens of Atlanta, and to which the street railway men will be invited for a reception on the evening of the first day. Our engraving shows the exterior, the cosy ladies' cafe and the exquisite ball room. The floor of the latter is supported on 1,500 spiral springs, and is a gem both artistically and mechanically. The majority of the electrical and street railway men of the city are members of the club. The house was opened in 1884. Major Livingston Mims is president, and J. C. Courtney, secretary and treasurer. The membership is about 300, resident and non-resident. Every department is perfect in its appointments, and, the gentlemen in charge, the most generous hosts. There is no club house in the South that has entertained as many distinguished men.

#### PUBLIC WORKS.

The magnificent new water works system, which has cost \$821,069, has two pumping stations, both on the Chattahoochee river. Four Gaskill horizontal compound condensing engines and fifteen boilers, a reservoir of 170,000,000 gallons, a filter plant capable of 1,000,000 gallons with fifty-six miles of iron pipe, complete the list of appliances in general. The pumping capacity is 20,000,000 gallons per twenty-four hours. The water is of excellent quality.

The city is lighted with 949 arc lamps from the Georgia electric light plant. This magnificent establishment is at the corner of Davis and Thurmond streets, and is the largest in the South with one exception. The building is fire proof, and in the dynamo room may be seen sixteen 50-light arc machines (city), three 50-light

arc machines commercial, two T.-H. M. P. 100-kilowatt 500-volt generators, three 2,000 light alternators, one 1,300 light alternator, one 1,000 light alternator, four T.-H. M. P. railway generators formerly used by the Consolidated. All equipment is General Electric. In the engine room are two double compound Mc-Intosh-Seymour engines of 500-horse-power, one Harris-Corliss of 800, one double compound Green engine of 900, and one 125-horse Armington & Sims. All but the last named,

in this service; this is furnished by this plant. Besides the city lights there are in use 556 75-candle-power series incandescent lights, 120 commercial arcs, 325-horse-power rented to motors, 11,000 incandescents and 70 alternating arcs. H. T. Edgar, the general manager, will extend a formal invitation to the convention to visit his plant.



H. T. EDGAR.

**THE STATE CAPITOL** is an imposing building of oolitic limestone, and Georgia granite, and marble. It is 325 feet long; 172 feet wide; to top of dome, 237 feet high; top of figure of liberty, 257 feet; diameter of dome, 75 feet. It cost \$1,000,000.

**THE EQUITABLE BUILDING** is the Monadnock of Atlanta, being Atlanta's electrical center. It is a handsome affair of Milwaukee pressed brick, eight stories high, with 285 offices. It cost \$100,000, and was planned by Burnham & Root, Chicago. The East Atlanta Land Company owns the land and structure. The Consolidated offices are on the third floor, and President Hurt's on the second.

**MONUMENTS.**  
The Hill monument stands in the State Capitol, to commemorate the life and work of the late U. S. Senator Benjamin H. Hill.

The McPherson monument commemorates the gallant federal officer who fell in the battle of Atlanta. It consists of an inscribed base, supporting heavy cannon set on end. The railing about it consists of barrels of muskets.

The Henry W. Grady monument, standing west of the special track work of the Consolidated, on Marietta

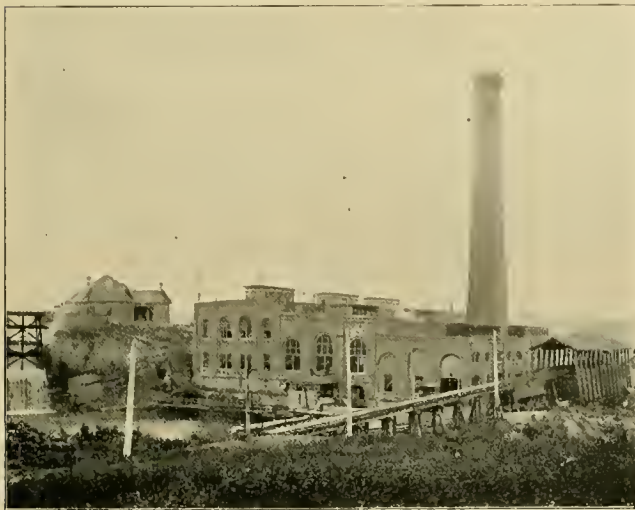

EXTERIOR GEORGIA ELECTRIC LIGHT PLANT.

are run non-condensing. Nine return tubular 250 horse-power Bigelow boilers and one McIntosh furnish the steam. Harris, Blake and Dean pumps are used. The water from the condenser is dropped through a 48-foot tower filled with brush as a cooler. No fans are required. Coal for the plant comes over a half mile of special electric railway track. An ordinary open car carrying two W. P. 30's is used to tow the coal cars. When loaded they are on a slight down grade, but are empty going back. Five hundred kilowatts are required

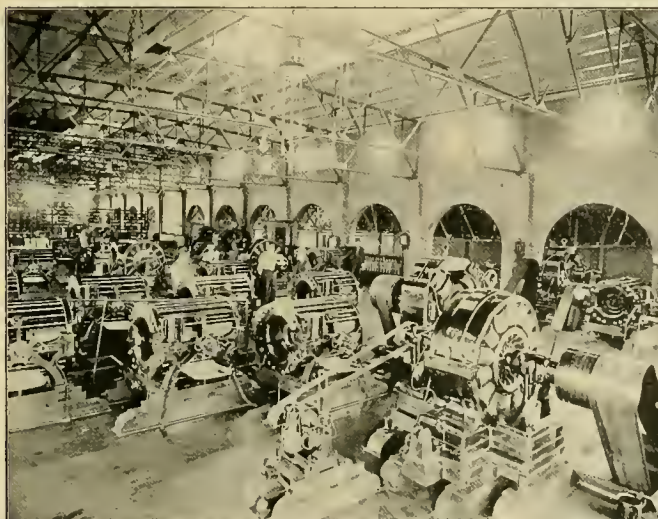

DYNAMO ROOM.

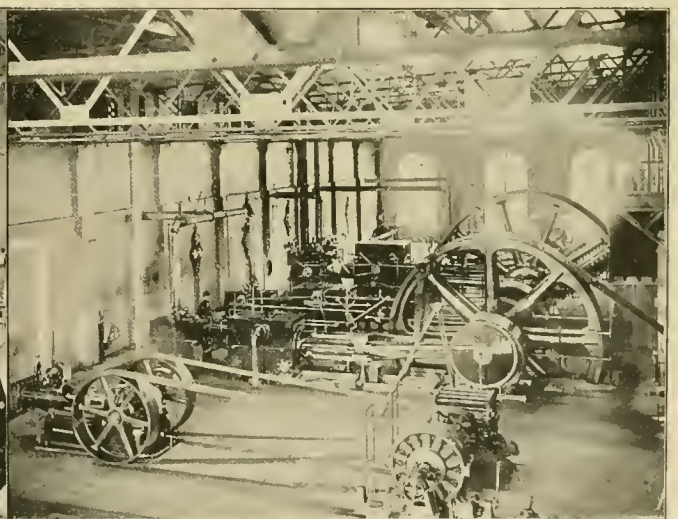

ENGINE ROOM.

GEORGIA ELECTRIC LIGHT PLANT.

street, west of Broad, is the magnificent heroic statue of the brilliant young pacificator, Henry W. Grady, the most widely known man that Atlanta has placed before the world. His heroic efforts for the city, state and county at large, his wide charity and his earnest life is fittingly honored in this grand piece of work. His other monument is the greatest of southern papers, the world famous Atlanta Constitution, to whose staff Joel Chandler Harris, Frank L. Stanton and other literary celebrities belong. City Editor Adamson has given distinguished consideration to the Street Railway Association.

The fire department is magnificently organized and efficiently managed. Last year 289 alarms were answered, with a total risk of \$1,777,000, and a total damage of only \$96,000. The expenses for the year were \$81,900.

The public schools, the pride of Atlanta, are the best managed and most complete in the south. Every opportunity is given, both for boys and girls, white and negroes, to become intelligent and useful citizens of this distinctively American city. In the high schools there are 17 teachers and 875 students, and in the white grammar schools 130 teachers and 8,000 pupils. The colored grammar schools have 40 teachers and an enrollment of 2,300. The grand total enrollment is 11,240, and the cost of tuition per pupil \$11.62. The total school population is \$15,816. What city can show a better record? Besides this, several institutions of higher learning, the Technological Institute, and medical colleges, add to the culture of the place. The libraries of the Young Men's Library Association and the State Capitol are rich in rare and interesting material, both collated and original documents.

The splendid natural drainage of the city is supplemented by 54½ miles of sewers, and 300 miles of sidewalk make the streets clean and easy of passage. In 1893 more than six miles of streets were paved, giving a total of fifty-seven miles thus provided. The paving is mainly the excellent Belgian block, with some brick, some asphalt and considerable chert.

Atlanta is a religious center as well, containing 100 church edifices, with a seating capacity of 60,000. All are well attended, and 20 missions are supported. A flourishing Y. M. C. A., provided with an elegant building, is doing a splendid work among the young men.

The Kimball House is within a block of the Union depot. It has a large number of comfortable rooms and sets an excellent table. Many street railway men have engaged quarters here, and Manager Porter will show the guests and strangers every attention. It has been for many years the headquarters of political gatherings, and many exciting events have occurred there.

#### COMMERCIAL.

The gateway of the south, with the railroads mentioned above, is a distributing point par excellence, as may be guessed, from the fact that she has 220 wholesale houses, selling \$80,000,000 worth of dry goods,

drugs, boots and shoes, hardware, liquor, tobacco, cotton, etc. There are 15 banks doing business in Atlanta, with a total capital and surplus of \$4,000,000, and deposits of over \$7,000,000.

Atlanta is a port of entry, and the business done through it is surprisingly large. The material imported is chiefly carpets, burlap, cigars, tobacco, watches and jewelry, bronze and ornamental glassware. The home pride which distinguishes the citizens and merchants of Atlanta, makes every year tell in the amount of duty collected.

Of course the city's prominent position in the great cotton belt gives it unusual prominence as a cotton center. In 1872, the total number of bales handled was 16,000, increasing in 1873 to 20,000, and last year to nearly 300,000. The two compresses located in the city have an annual capacity of 600,000 bales, and the storage capacity reaches 60,000 bales. The admirable shipping facilities of the city continue each year to make it more important as a cotton point.

In direct touch with cotton comes the cotton seed oil industry, in which Atlanta ranks as the largest center east of the Mississippi river. The three mills at Atlanta have a crushing capacity of 400 tons a day, or 60,000 tons for a working period of six months, costing \$750,000 and giving employment to 500 men and as many more in buying and shipping seed in the country.

The by-products of cotton are: oil, used for cooking purposes in Europe, for packing sardines and for mixing with olive oil; the inferior oil is utilized for soap, signal oil, paint and in many mechanical processes as a lubricant; cotton seed meal, for cattle food; ammonia and potash, for fertilizers, and the linters or short staple cotton adhering to the shed after passing through the gin; this is obtained in small quantities by the most expensive machinery.

There are catalogued in and about Atlanta nearly 600 manufactories, having a total capital of \$14,000,000, and a product of nearly \$29,000,000. They comprise foundries, machine shops, cotton factories and accessories, ice, stone, brick and terra cotta, lumber, wire and iron works, and all the other necessary producers of a central point upon which so large and increasing a population is dependent. The lumber demands the attention of 26 establishments, which handle little less than 100,000,000 feet per annum. Walnut, hickory and other hard wood, as well as long leaf pine, are abundant and easy of access. The iron, which is mined in great quantities, both in Tennessee and Alabama, employs 2,000 men, and turns out a variety of machines and utensils. Coal and coke are abundant, and water power, adjacent to the city, promises considerable increment of facilities for cheap power for many purposes. Manufactured cotton claims several establishments. The Atlanta Mills, started in 1879, have 13,000 spindles and 330 looms; the Exposition Mills, started in 1883, have 16,000 spindles and 600 looms; the Fulton County Company has 12,000 spindles and 450 looms. Now, there are, all told, 70,000 spindles, employing 2,500 hands.

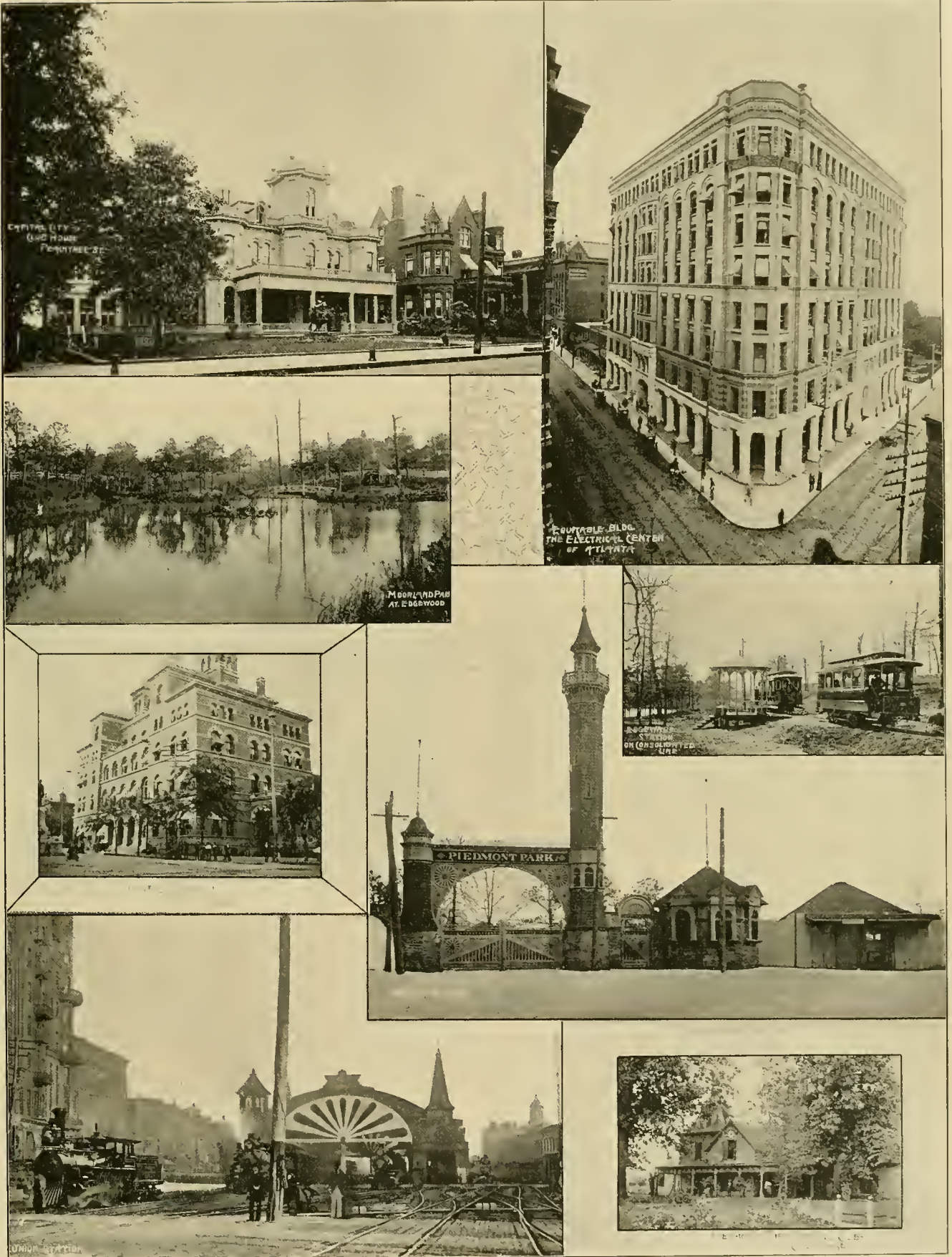

A FEW GLIMPSES OF ATLANTA.

Other establishments of note comprehend glass factories, buggy and carriage factories, coffin factories, paper and cloth bag mills, trunk shops, and almost every conceivable material of use to the large and varied populace dependent upon Atlanta for its source of supplies.

Agriculture returns wheat, oats, corn, grass, orchard products, and, greatest of all, cotton, while market gardening brings in rich returns, and small fruits flourish. With the splendid railroad facilities, this portion of the state's wealth will become more valuable and attainable as the years pass.

#### BATTLES AROUND ATLANTA.

During the war between the states, five pitched battles may be enumerated as belonging to the region adjacent to Atlanta. They are chronologically arranged thus:

The battle of Peachtree Creek, on July 19, 1864, when a part of the Army of the Cumberland, and Reynold's brigade of Walthell's division of the Confederate troops were "mixed" in lively engagement. The Federal troops crossed Peachtree Creek and attacked the Confederates at Moore's mills, but were driven back. The second battle of Peachtree Creek occurred the following day, when a general attack was made upon the Federal army, which was partly intrenched, by General Hood. It was a bloody and desperate battle. The Battle of Atlanta was fought July 21, 1864, when the Federal troops assumed the offensive, and attacked Cleburne's infantry division and Wheeler's cavalry upon the extreme right of the Confederate lines. The Federal troops advanced in three lines, but were driven back after a desperate struggle. The second battle of Atlanta followed on July 22, with an attack on the Federal troops, which were entrenching on the north and east sides of the town. James B. McPherson, major-general, commanding the Army of the Tennessee, and Major-General William H. S. Walker, of the Confederate army, were killed in this engagement, which was particularly bloody.

The fourth was the Battle of Ezra Church, which began July 28, in a hard struggle between Hood's troops and the Federal army west of Atlanta. After this engagement, until September 4, there was a series of affrays, upon which date Atlanta was evacuated by the Confederates.

#### THE SUPPLY BUSINESS IN ATLANTA.

Naturally as the principal distributing point for the south-east, Atlanta has its quota of sales offices for street railway supplies, which, while not many, are active and efficient, and the numbers will increase as the importance of the southern trade becomes greater year by year. The Atlanta offices of the General Electric Company, are located in rooms 641 to 647 Equitable building, where the business of this great company is transacted for the states of South Carolina, Georgia, Alabama, and Florida. The company has also a warehouse at the corner of Marietta street and Jones avenue, where a goodly stock

of supplies both, for the street railway and light work is carried. The Thomson-Houston Company established its Atlanta headquarters in 1888, in charge of H. E. W. Palmer. In May 1892, when the General Company was formed, these offices were combined with those of the Edison, and Mr. Palmer continued as manager. Mr. Palmer however resigned in February, 1894, and was succeeded by A. F. Giles, who has continued the fine business built up by Mr. Palmer and added materially thereunto. There are fifteen employes attached to the office, the chief of whom are: R. D. Bullen, S. W. Trawick, F. W. Wilcox, Frank Lederee, F. A. Hills, and G. L. Thompson.

The Johnson Company, of Johnstown, Pennsylvania, has an elegant suite on the fourth floor of the Equitable, where W. W. Kingston is chief executive, and Eugene Thomas assistant. No cosier or more finely equipped offices can be found anywhere, and no more genial gentleman than Mr. Kingston is to be found in the land of hospitality. The display of Johnson rails is complete, and on Mr. Kingston's books may be found orders from all of the principal southern street railways.

J. W. Taylor, who is agent for the Stillwell, Bierce &



JOHNSON COMPANY'S OFFICE.

Smith Vaile Company, of Dayton, O., has an office in 21 South Forsyth street. He does a business of from \$75,000 to \$100,000 a year in ice machines, water power, cotton machinery, and heaters and purifiers. He has sold water power plants to several southern street railways.

The Carnegie Steel Company has a sales office in the Gould building, in charge of Walter M. Kelley, whose extensive knowledge of street railway men and needs in the south stands him in good stead.

The Southern Belting Company does a fine trade in belting and power transmission, handling several well-known brands.

C. H. Willcox represents the Lane & Bodley Engine Works, of Cincinnati, and his labors have been crowned with success throughout the territory.

## ATLANTA'S STREET RAILWAYS.

The beginning of the street railway idea in Atlanta and consequently the beginning of Atlanta's present magnificent vistas, was in 1871, when the West End road was organized with Col. G. W. Adair, Richard Peters, John James and Maj. B. E. Crane at the head. Fourteen thousand dollars were subscribed and ten thousand more added by Col. Adair and the road was. On the eighth day of September, 1871, the first fare was collected. It was ten cents, and carried the passenger to McPherson's barracks. Horses, of course, were the motors, with flat rail and Stephenson cars. New lines followed rapidly, and soon Marietta, Decatur and Peachtree streets were provided with comfortable if not rapid transit. The first officers of the company were: Richard Peters, president; G. W. Adair, secretary and treasurer, and E. C. Peters, superintendent. Richard Peters, to whose faith in



RAPID TRANSIT.—VINTAGE OF 1871.

Atlanta's future, and Col. Adair, whose generous help at a time of need, made the first line possible, should be and are honored in Atlanta's annals.

The West End line was established in 1871 as noted, but soon the growing city compelled the Marietta street line a year later, and the Decatur street branch. In August, 1872, the Ponce de Leon road was opened, and the next year Taylor's hill was equipped as was McDonough street. Whitehall, the great retail street, fell into line in 1873, and Atlanta had eleven miles of road under competent management. E. C. Peters, superintendent of the first line, and to whom we owe our data for the the above, was chairman of the first committee of the American Street Railway Association which investigated the claims of electric traction. Richard Peters, the first street railway builder, now deceased, made a large fortune in real estate, worth now several million dollars.

The Atlanta City Railroad and its lines was followed by three other companies, which now compose the Consolidated. They were: The Gate City, built in '88, by Nelson, De Grieve and Stevens, and equipped with horse traction, bought in by Mr. Peters a year later; the Metropolitan, running on Pryor and Fair streets, and built by Dr. Rankin et al in '86, but sold to

the Aaron Haas Company in '88 and changed to dummy; the Fulton County Street Railway, built by the Thomson-Houston Company and local capitalists, in the fall of '88; this included the nine mile circle and Peachtree street. This was the first of electric railways in Atlanta.

The Atlanta & West End, now a traction line, was built 1886, by Col. Healy and others, composing a stock company. It was also a horse line until absorbed by the Traction Company.

The Chattahoochee line, now known as the Collins Park & Belt, was built in '91, and was an electric line from the first. It had no immediate excuse for building, but is fast developing a fine residence district.

The Lithia Springs Railway Company has in prospect a 22-mile line to Lithia Springs, a resort and mineral spring west of the Chattahoochee river. The line will develop suburban property, as well as afford easy transit to a lovely spot, where boating and bathing may be indulged in. Henry Camp is president, B. F. Curtis, vice-president, and Thomas Camp, secretary. The financial stringency and the consequent torpidity of real estate transactions have delayed the building of this line, which ought, under competent management, to be a paying concern.

The further erratic career of the present Traction Company is it not written in the chapter upon that line.

## THE ATLANTA CONSOLIDATED STREET RAILWAY COMPANY.

In the year 1871, the primal Atlanta street car made its weary round on the mule plan. It wasn't an extensive affair and the rolling stock not quite up to the elegant standard of work at present considered au fait in Atlanta. The modest and retiring cracker gave up his choicest shave-tailed bay mule to the necessities of advancing progress, and Mr. Stephenson, of New York, provided a comfortable car of the latest pattern. This was not, however, the ultimate.

Many changes were in store for the line as told in our history, but the most important was the consolidation which occurred twenty years after the date of the foundation.

So then after the narrated tribulations the Atlanta Consolidated Street Railway Company was incorporated in 1891 with the following systems represented by the track rolling stock and motive power: The Atlanta and Edgewood Street Railway Company, The Gate City Street Railway Company, the Fulton County Street Railway Company, the Metropolitan Street Railway Company, the Atlanta Street Railroad Company and the Atlanta and West End Street Railway.

The directors of the new company were: Joel Hurt, R. J. Lowry, S. M. Inman, W. C. Sanders, Ernest Woodruff, Henry Jackson, H. A. Inman, J. Carroll Payne, J. T. Dargan, all of Atlanta, and J. H. Watson, of New York city. Five of these gentlemen are in the board of management and owners of the controlling stock. It is essentially an Atlanta company and loyal to that beautiful and enterprising city to the core. Each one is interested in from one to a dozen home enterprises and puts

his money and his talent into the advancement of Atlanta and its fine street car system.

The first thing that the new management resolved upon was the rehabilitating of the road, and H. N. Hurt, now superintendent, and his assistants took immediate steps to lay new track and connect up the various small roads into one coherent system. This took time, money and patience, but it succeeded beyond all hopes to the advantage of every dweller in the Gate City. Mr. Hurt found in the beginning that no corner in Atlanta was at a respectable angle, and this complicated matters to some degree. The success of his engineering methods, however, may be seen by the visitor who may ride over the system.

The reconstructed Atlanta consolidated is now represented by twelve routes, in the city, in streets paved with the solidest and best laid Belgian block and in the outlying districts in the regular county roads, which are first-class specimens of good road building. A large amount

of intense interest to the visitor. It is seven miles in circumference and 1,500 feet high. The exposed rock above the surrounding surface is reckoned to contain seven to eight billion cubic yards. There is a present output of 30,000 paving blocks a day, and the product is controlled by Venable Brothers, of Atlanta. The blocks are shipped to all points both for paving and structural work.

In using the granite blocks for paving to T rail, it has been the custom to lay them flush to the rail and smash the grooves by the ordinary flange pressure. Mr. Hurt considers that method both efficient and practical, although rather "rough" on both passengers and wheel flanges at first. The cost to the street railway for paving is \$1.50 a square yard. On outside lines considerable chert paving is in vogue. This is a silicious material which hardens under exposure like asphalt or cement. It is laid on a Telford foundation. The granite blocks are laid on sand.

Some special track work of interest is the intersection

NO.	ROUTE.	PAVING.	RAIL.	LENGTH.
1	Marietta and Decatur, . . .	Belgian block.	45-lb. D. Johnson girder.	23,943 ft.
2	Edg. Ave. Boul., Jack. & Pet.,	" "	Johnson D. and 63-lb. T.	34,443 "
3	Houston to Edgewood, . . .	" "	40-lb T.	38,770 "
4	Edgewood Ave. & Whitehall,	" "	53-lb. Prov. Girder & J. G. D. & Elec. T 40-lb.	29,970 "
5	Cap. Ave. & W. Peachtree, .	" "	45 T and Johnson D.	18,514 "
6	Decatur St. to Decatur, . . .	" "	" "	37,893 "
7	Smith St. to Ponce de Leon, .	" "	" "	20,788 "
8	Fair St. to Grant Park, . . .	" "	" "	12,878 "
9				
10	Peachtree, S. Pryor & Ga. Ave.	Asphalt and brick.	T, D, and Johnson girder Y.	36,442 "
11	Washington & Courtland, . .	Belgian block.	T and D.	22,941 "
12	Jones A., Hous. to P. de Leon,	" "	"	20,629 "
13	Tatnall & W. Hunter, . . .	" "	"	10,294 "

There are 63.7 miles of track in the Consolidated system.

of cutting and filling was necessary on several lines, particularly those on the nine-mile circuit and the Decatur route. The accompanying table gives the names of the routes by the streets which they follow and the style of paving obtained thereon, as well as the style of rail and length of the line in feet.

In the table, the Johnson girder is denoted by the letters J G and the section as D or Y, according to the style. Mr. Kingston, the southern agent, has sold the bulk of the rail to the Consolidated. Route number 9 is not yet built upon.

The magnitude of the Belgian block pavement is explained by the fact that close to Atlanta there are magnificent quarries of the best of granite for this purpose. Peachtree street, the magnificent residence thoroughfare of Atlanta, is paved with asphalt. Granite blocks are here used as liners for the rail.

Stone mountain has the largest deposit of granite in the world that is commercially useful. The black dome of the mountain is visible for twenty miles. It lies sixteen miles from Atlanta and will be a feature

of Broad and Marietta streets, where all cars of the Consolidated meet and pass. It is exactly like the Rochester track work recently illustrated in the REVIEW and like it designed by the Johnson Company of Johnstown, and sold by the Atlanta agent, Mr. Kingston.

The Decatur line of the Consolidated which is now equipped with electricity, was formerly a dummy line. It runs to Decatur, a village of 6,000, six miles from Atlanta. Decatur was intended to be the center of the future great city, but Providence and the real estate men ordered it otherwise. On this line are several small stations, at which cars stop to allow passengers to land and mount the cars with convenience. The run to Decatur is a beautiful one and no visitor will omit it.

There are on the lines of this system a number of pleasure resorts, which add greatly to the receipts of the company. They are mentioned more particularly in the chapter on Atlanta. Suffice it to say briefly that the Base Ball park, leased by the company, is reached by routes 2 and 4 (see table); Ponce De Leon Springs by routes 2, 12 and 7; Grant Park by 8 and 10; Piedmont





PONCE DE LEON SPRING.  
EAST LAKE.



SCENE IN LITTLE SWITZERLAND.

Exposition by 2 and 10; Decatur by 6, and Inman Park by the Inman Park cars of the Consolidated.

The rolling stock of the system consists of forty-five cars all told. Lewis & Fowler and Stephenson divide honors with the Brill Company and the Pullman people in their manufacture, and last but not least ten are of the brand of the Atlanta Consolidated. Bemis trucks are used almost exclusively, but a recent order of Graham's well known specialty is en route. The Lewis & Fowler register is exclusively used, and Mr. Hurt considers it the only register for his lines.

The motor equipment consists of eighty-two Thomson-Houston S. R. G., 15-horsepower, two to each car; four Westinghouse 30's; two G. E. 800's. The overhead material is of the Thomson-Houston type. All but five miles of line will be found of side pole pattern, with the five miles mentioned equipped with single side arm construction.

Four car barns are used for storage; one on the Decatur line, one at Exchange place and Edgewood avenue, one at Inman Park, and one at the plant. The latter is the most important and is shown in our engraving.

To furnish power for the sixty-five miles of line, the Consolidated formerly was compelled to utilize the Georgia electric light station, but since the rehabilitation of its own plant, as later described, it has done away with the renting method.

The "plant," as it is called, consists of the station, machine shop, foundry, car barns, and offices, all complete to the last detail of convenience and economy.

THE POWER STATION

of the Consolidated is situated near the track of the Richmond & Danville Railroad Company, which affords excellent coal shipping facilities. It may be reached by the electric cars of the Nine Mile Circle, which pass close to the site of the plant. The plot of ground occupied is three miles from the center of the city, and but a short distance from the Exposition grounds, where the association will hold its meetings and where the exhibits will be placed. Besides the power house proper, there are, adjoining it, two car barns and the repair shop, both of which will be specially mentioned further on. An interesting foundry and two small oil storage houses complete this list of buildings. The three last named are carefully isolated to guard against fire.

The power house proper is a one story brick structure, running 100 feet north and south by 50 east and west. The boiler room, to the south end, measures 40 by 50 feet, leaving a 60 by 50 foot engine room.

The boiler room shelters three Bigelow return tubular boilers, made by the Bigelow Company, of New Haven, Conn. They measure 72 inches by 16 feet, and contain

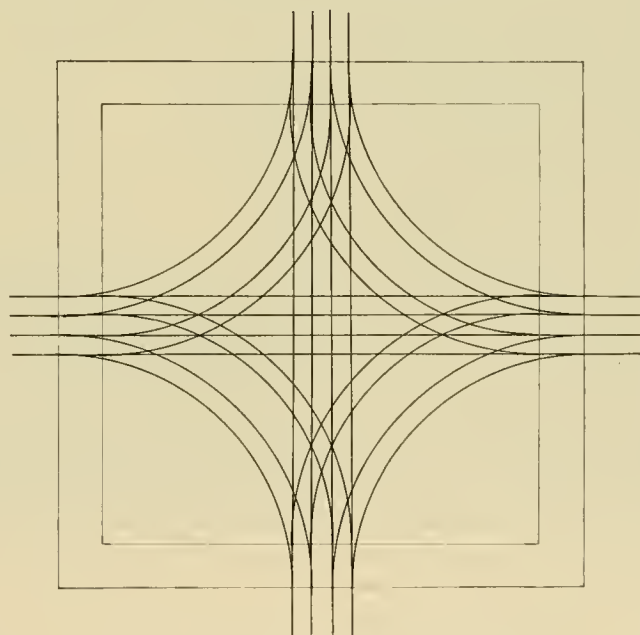

SPECIAL WORK, BROAD AND MARIETTA STREETS.

96 four-inch tubes each. Each boiler is rated at 150 horse-power. Besides this equipment, there has been recently added a big Manning vertical boiler, which stands 27 feet high. It holds 284 two and a half-inch tubes 15 foot long. The fire box is 84 inches in diameter and 48 inches deep. This boiler is rated at 250 horse-power.

#### THE ENGINE ROOM

In the engine room are two 20 by 40-inch C. & G. Cooper Corliss engines, running at 88 revolutions per

was done away with, and the faithful Coopers coupled direct, as will be related, and a direct coupled unit was resolved upon.

It fell to the engineer and Superintendent Hurt to remodel the plant without shutting down, and the Cooper engines were retained, doing as good work as ever, and another unit installed between them, of a heavier type. To do this the plant had to be kept running regularly at the same time.

Therefore, a new 300-Kilowatt Westinghouse mul-



EDGEWOOD AVENUE CAR BARN.

INTERIOR OF MACHINE SHOP.

CAR BARN AND WOOD-WORKING SHOP.

POWER HOUSE—CONDENSER TANK AND COOLER.

(VIEWS OF CONSOLIDATED COMPANY'S PLANTS.)

minute. From the start they have done splendid service, and still are doing yeoman work. They are now coupled direct to 300-kilowatt Westinghouse machines, but formerly ran seven D 62 Thomson-Houston generators, driving a 40-foot counter shaft by means of Munson belting. The service of the engines was in every particular satisfactory, but increased demands on the station called for further power, and the counter shafting

tropical was installed just in line with the receiving pulley on the shaft. This generator was wired up and finished, and, after shutting-down time at night, the belt was transferred from the shafting to the new generator. The new machine and the three old ones still left on the shaft pulled the load until another 300 kilowatt machine was installed at the other end of the shaft, and, belted direct to the other Cooper engine. Next, all

of the old generators and shafting were removed, and the foundation laid for the direct coupled unit hinted at above.

This foundation was to bear a heavy load, so it was built up solidly of concrete in the following formula:

One part Portland cement.

Two parts Louisville.

Four parts granite rock.

This was laid to a depth of 13 feet and covered with blue lime stone above cap stones, weighing 60,000 pounds, making the total foundation weight 750 tons. Previously to this performance, however, an order had been placed with Rankin & Fritsch, engine builders, of St. Louis, for one 800-horse-power tandem compound condensing engine, designed by the Rankin & Fritsch engineers after specifications furnished by Chief Engineer Elliott, of the Consolidated Company. The cylinders of this engine are 22 inches high pressure and 40 low pressure, by 48-inch stroke. Coupled to the shaft of the engine is a Westinghouse 500-kilowatt railway generator, designed for 90 revolutions per minute.

#### A WATER WEAIGHER.

The awful mendacity of water meters and the necess-

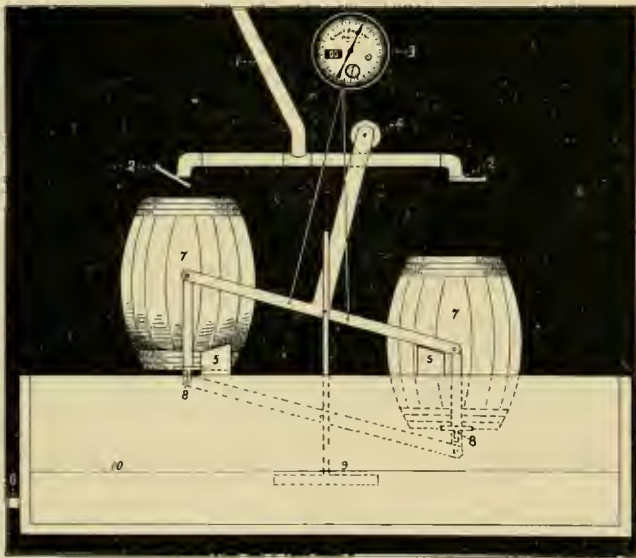

ity of weighing water to determine cost of power, has driven the inventive genius of the power plant to the dividing of the "water weigher" illustrated.

The automatic weigher is contained in a rectangular wooden box, 2 by 3 feet in dimension and 8 feet long. Inside are two barrels, one on each side of a pair of levers. When the barrels are in mid-stroke the levers are horizontal and forged to them is an upright on which at the end is the counter-balancing weight. Across the tops of the barrels passes a water pipe which comes from the discharge pipe of the condenser. In the pipe are two valves which are opened by the barrels automatically as they come to the top, and at the bottom of the barrels, two similar valves discharge the water as the barrel sinks. The latter valves are the larger, in order to make it certain that all water is discharged from one barrel before the other one

drops; it is not necessary to change the weight in order to adjust the barrels, but simply to alter the angle to one more acute. The boiler feed pump is connected to the bottom of the tank and a float controls the movement of the barrels. In fact, the barrels must stand until the float sinks and pulls a latch which allows the barrels to discharge. A street car stationary register is attached to the barrel levers and registers as the barrel sinks. It is a neat idea.

#### THE SWITCH BOARD,

At the station is of white marble, brass mounted and small for the capacity of the plant. On it are mounted three Westinghouse new type circuit breakers and one Westinghouse tank lighting arrester. The latter, "says the engineer," has been a very efficient device. All machines are wired to standard underground lead covered cable. Sixteen feeders run out of the station each provided with an ajax switch. All feeders are carried above ground.

#### THE SHOPS.

One no inconsiderable item in connection with the street railway plant is the finely equipped machine shop and foundry, situated at the "plant." The first named is a wooden structure of one story, directly north of the power house. It is 25 feet by 50 feet in dimensions, and contains a full equipment of tools. There is a Fay & Scott lathe, a 34-inch machine, and a Lodge & Davis, of 18 inches. Lodge & Davis is also represented by a planer 24 by 24 inches by 6 feet, and a 24-inch back gear drill press. A Watson & Stillmon wheel press is a useful piece of equipment, and Mr. Elliott says any road of more than six cars should have a wheel press of some description. The shop is operated by a 10-horse-power stationary T.-H. motor, but usually three or four horse-power are amply sufficient for the work. Among the minor features is an adjunct for boring out the axle sleeves, a rod with a right and left thread, which runs out the shavings made by the tool. One important labor saver of the establishment is the "dinkey." It is a flat car mounted on an old truck and equipped with two 15-horse-power motors. It is a queer and clumsy looking affair, but useful, as most clumsy things are. The shops and barns are inter-connected by tracks, so that parts can readily be shifted from place to place. Superintendent Hurt has great regard for the "dinkey."

The Consolidated puts its foundry to use in casting all its own car wheels. The proportions in the wheels is 400 pounds scrap, with enough native Alabama pig iron, 200 pounds, to give durability. A home made chill is used, and the wheels are cast in iron flasks. There are two annealing pits, and cranes for handling the completed product of the foundry. These home made wheels have  $\frac{3}{4}$ -inch flanges, and last, on an average, six months. The motor wheels weigh 300 pounds, and cost one cent a pound to manufacture. The company makes its own brake shoes. These are of hard grade, weigh twenty-one pounds, and as the motormen are strictly forbidden to skid the wheels, they do very well.

Gears, as well, are cast at this foundry. The axle gear wheels are cast solid, of  $\frac{3}{8}$ -inch web and cup shaped. After being bored they are pressed onto the axle. An iron pattern is used in moulding gears. It is made with an excess of  $\frac{1}{4}$  of an inch to allow for shrinking, and a pattern may be lifted from the mould without rapping, so that the gear teeth do not need cutting. This is accomplished by packing sand about the pattern in the usual fashion, and a brass ring toothed similar to the gear wheel is placed on the surface. The pattern is then removed by a tripod screw jack, whose feet rest on the ring and the lifting rod introduced in a threaded aperture in the middle of the pattern. A gear cutter of the company's own make, has two circular cutters working in train. The pinion blanks are bought and the teeth cut by this machine, which finishes the cut at one passage. They cut 4 pinions at once. Armature and axle bearings are also cast at this foundry, as well as trolley wheels. An iron mould is used for this latter process. The mould is in three parts, each provided with a handle. When the brass is poured into the mould the upper part is lifted off, and the split ring which makes the groove is taken out.

#### THE BRASS FOR THE ARMATURE BEARINGS.

The armature brasses are made eccentric. They are  $\frac{1}{4}$  inch thick on top and  $\frac{1}{2}$  inch thick on bottom. This has proved a most valuable feature, as the brasses last about three times longer than the concentric brasses, and it is a very rare thing for an armature to hit the pole pieces.

Frame bearing brasses are cast in a sleeve embracing the axle from the gear wheel to the car wheel opposite. No collar is used next the wheel. The sleeve is turned to fit the axle and has an oil cup on the upper side, and all waste oil is led directly into the gear case, which latter is cast of a composition of scrap. All insulated wire used in winding armatures is waxed, and the armature is not baked. Insullac is the insulation used.

Being a considerable distance from the base of supplies the consolidated is able to make some supplies cheaper than they can be bought, but ordinary practice finds home made in the long run more expensive than regularly manufactured material. In addition to this fact, the proximity to raw material is an advantage to the consolidated which few other systems enjoy. It will not be long, however, before supplies will be regularly manufactured at some central southern point, and why not Atlanta?

#### THE CAR BARN

is of frame 100 feet by 200 feet, and protected against fire by the manufacturers' automatic sprinkler. Here is storage room for 110 cars and a transfer table of Wharton's pattern.

#### THE COOLER.

At the rear of the power house stands a plank cistern built on the surface of the ground. It is rectangular and 16 by 20 feet by 20 feet high. At the base are four 6-foot fans driven by two old S. R. G. 15-horse-power

motors, calculated to speed up to 400 r. p. m. The hot water from the condenser is delivered on top of this cooler by the condenser itself. The supply of water comes from spring and surface water, which runs ten tons an hour. Inside the cooler is a stack of 1 by 2 inch rough pine lumber, laid cob-house fashion and roughed with a pick ax. The water is distributed over these timbers by sixty-four one and a quarter inch pipes, 8 feet long, and perforated on top with  $\frac{1}{4}$  inch holes six inches apart. As the water goes down this torturous course, the fans cool it by means of the induced breeze, and the condensing well is supplied with cool water, and what cool water means for this purpose can be appreciated only by a southern engineer. A Smith-Vaile 12"x16"x24" duplex pump lifts the water to the top of the cooler. It runs by gravity into the condensing tank. This is not an entirely new practice, but is unique, we believe, in street railway work.

The condensing pool is a brick lined well 55 feet in diameter and 10 feet deep. After passing through the condenser the water goes through the above described cooler and back to the pool to be used again.

The new 500 horse-power generator is a 10-pole machine with the brush holders carried on the engine shaft. All three of the machines in the plant are over compounded 10 per cent.

#### THE COLLINS PARK & BELT RAILROAD COMPANY.

The Collins Park & Belt Railroad Company was organized three years ago as the Atlanta & Chattahoochee Railroad Company, and was originally intended to develop the beautiful rolling country lying west of the city, out to the Chattahoochee river, a section redolent with historic interest and still holding the clearly defined outlines of old breastworks, redoubts and camps of the late war. A ride along the line is an historical study of those lively times. This region will at some time be without doubt, a fashionable place of residence, as new and well built streets are being cut through at the present time.

The road was organized in 1891, with J. K. Polk Charleton as president, and D. G. Jones as secretary. The building was an unusually costly piece of construction, as many deep cuts and long fills had to be made and several trestles and bridges built. The first manager, Avery Chastien; the second, J. M. B. Carleton, and the third, R. L. Caldwell. At this time the line passed into the hands of a receiver and the court appointed W. Darr in that capacity, to whose constant watchfulness, great adaptability and general ability the present good condition and flourishing business of the line is mainly due. The line has, under the present management, added so many features that, in spite of the failure of the real estate venture on which it was built, it is doing very well—in fact, much better than would be imagined from the scarcity of houses along the line. The heavy growth of forest on each side of the track for a greater part of the distance furnishes ideal picnic grounds and the historic associations of the adjacent land bring



POWER HOUSE—COLLINS' PARK AND BELT RAILROAD.

many visitors. Besides this, the western terminus of the road is at Bolton, a flourishing suburban village, ten miles from the Atlanta terminus, which is a short distance from the postoffice. The line is single tracked with switch back turnouts.

Fifty-six pound T rail, spiked direct to sawed ties spaced 24 inches from center to center, makes a solid road-bed. In the city the paving is done in Belgian block, placed flush to the rail, as is the custom. The track is cross bonded with galvanized iron supplementary, which is a great convenience in the country section, as any particular section of track may be removed or disabled without affecting the return, and consequently cars may be operated on either side of the break. The run over the line is made in about an hour and a quarter every half trip, and cars run on 30 minute headway. A considerable freight and express business is done. The principal commodities handled being sand, brick, tobacco, and cord wood, from which the road realizes an average of \$50 a month, with but two cars in service. These are flats and trailed, one a small car, for which a charge of 50 cents a load is made and the other larger, with a tariff of \$2.00.

A recently opened cemetery, at a point not far from the western terminus, has developed a paying funeral car business with no additional expense. The ordinary open car is used, from which the reversible back on one seat is taken. The two adjoining seat backs are then reversed and the coffin laid upon them longitudinally, with the pall bearers on either side to keep it from slipping sidewise. The seat backs perform this office for each end. The writer observed one funeral en route. The coffin was covered with flowers and accompanied by four pall bearers. In the other seat, and on the regular car preceding it, were the friends of the deceased. The innovation is kindly received and none but white citizens are accommodated by this service. The company charges ten dollars for each funeral, and from one to four a week pass over the line. A regular funeral car is in prospect, and Mr. Darr says that such a movement will tend to popularize the use of the cars for this service as well as to assist the cemetery company. Some other improvements will also be made in regard to the freight service,

notably a system of weighing the merchandise and creating a regular tariff. Picnic parties are frequent and the road is chiefly known and gets the bulk of its revenue from these three sources of freight, funeral, and fun.

THE POWER STATION

is a solid stone structure, situated  $5\frac{3}{4}$  miles from the Atlanta terminus, and 100 by 60 feet in dimensions, of which the boiler room occupies 40 by 60 feet. The engine room, in charge of D. A. McNabb, is equipped with two Allis-Corliss engines, both of 200 horse-power, 18 inch cylinder, by 44 inch stroke. The fly wheel is 18 feet in diameter and carries a 24-inch belt. It turns at 90 revolutions per minute. Belted direct to the engines are two Short dynamos, one of 300 amperes capacity and the other of 200. The smaller unit is kept always in reserve. They are of the 36-inch armature, multipolar type, using carbon brushes. The average daily output is from 120 to 160 amperes, according to freight, funeral and picnic traffic. In the boiler room are three horizontal tubular boilers, made by E. H. Jones, of Cleveland, O., and rated at 125 horse-power each. One is sufficient for the business of the station. Here are also a 200 horse-power Worthington feed water heater and purifier, and a 8 by 6 inch steam pump of the same make. The water for the boilers comes from a small stream, which approaches in its natural course, within 800 feet of station and the remainder of the way by a 2-inch iron pipe and a V-shaped trough. The water run from this improvised water works into an iron tank, 6 by

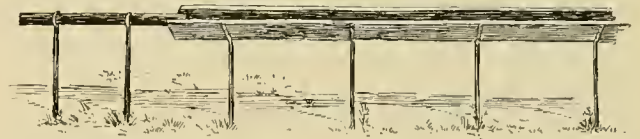

2 feet, and from this tank into another of the same kind, 10 by 8 feet. The sand and sediment is precipitated in these boxes, and from the latter it is pumped into the purifier to remove what remains of impurities. The coal used comes from Alabama, on the Western & Atlantic Railroad, to a point  $2\frac{3}{4}$  miles from the station. Where the railway crosses the steam line a switch is laid to connect the tracks, and the heavy coal cars, weighing 30 tons, are hauled successfully on to the electric tracks and to the power house, by any motor car that happens to be idle. In addition to the weight, the two 20-horse-power motors with the coal car are compelled to ascend a 4 per cent grade and go over a 40-foot curve. The coal costs \$2.00 a ton delivered thus at the power house.

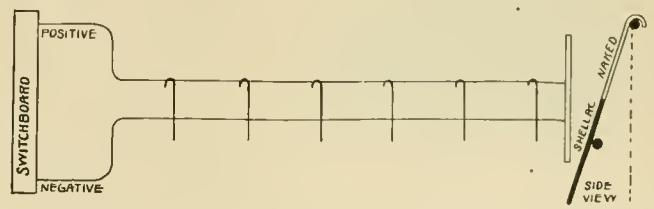

HOME MADE LIGHTNING ARRESTER.

In the station, two devices of home design attract one's attention. The first is a lightning arrester, which consists of two horizontal pieces of trolley wire eight feet long. The upper one is connected with the trolley wire and the lower one with the rail. The latter is about 2 inches out of perpendicular, as regards the upper wire, and 12 inches distant. From the top wire, pieces of No. 18 copper wire are hung, touching and resting against the ground wire. These cross-connections are naked on the upper half, but insulated at the ground wire contact point having been dipped in shellac. The shellac insulation, although very thin, is sufficient to withstand the 500-volt current, but allows the static discharge to jump to ground. Much trouble has been experienced with lightning at this point, and in addition to this affair mentioned, two other lightning arresters are also used, one of the Short pattern. At the western terminus a line arrester of a similar pattern to the one described, is placed in a small house to protect the insulation from moisture. This has a capacity of 125 fuses. On this arrester a small wire is used, so that if there is a tendency to ground, it can be blown from the station.

Lightning has worked such havoc, however, that during very heavy storms the plant is shut down. Although no tests have been made of the plant, the fuel used each day amounts to  $3\frac{1}{2}$  tons.

The work bench in the power house is supplemented by a home made lathe designed by the operators. It consists primarily of a frame made of cross ties sunk in the ground. It is provided with babbitted bearings and wooden caps. The tool for turning down commutators is a portable generator slide rest bolted to the frame. A big hand crank fastened to the armature shaft is the power used.

The station requires one mechanic, one fireman, one engineer, and the superintendent. There are nine cars in use and two in reserve. All were made by Brill, mounted on Dorner & Dutton trucks, and equipped with two 20-horse-power Short S. R. motors.

W. DARR,

receiver, superintendent, general manager, and, if need

be, engineer, electrician, motorman or conductor, is but 27. He was born in New York, became a master mechanic in the railroad shops of the Denver & Rio Grande, traveled in Mexico and other places, and finally, in 1890, learned all about Short electric railway goods, in Cleveland. He then became electrical and mechanical engineer of an Ohio



W. DARR.

street railway, but removed to Atlanta in 1891, in his present capacity. His office is at the power house.

#### THE ATLANTA TRACTION COMPANY.

After a romantic experience and lightning changes the old Atlanta Traction Company succeeded, early in 1893, in absorbing, boa-constrictor fashion, a large system known as the Atlanta City Railway Company. The beginning of the Atlanta Traction Company was in the Atlanta & Ft. McPherson line, which sprang forth electrically equipped in 1891. At that time H. L. Woodward was president and J. L. Mountain general manager. In the latter part of 1891, a line was built on Richardson



GLENN STREET POWER HOUSE—ATLANTA TRACTION.

street to Grant Park, and in 1893 the consolidation mentioned above was effected, and the Atlanta City Street Railway, with a line from Atlanta to Decatur (electric), bought. The latter also controlled a branch road to East Lake. By this addition twenty miles of road were united, and all equipped electrically. Before the latter purchase, however, the firm of Hines, Shubrick & Felder, and James W. English, Jr., had purchased a controlling interest in the Traction, and were the moving spirits of the consolidation. Mr. English later retired from the concern, but for a time managed the property prosperously.

The late financial stringency, however, had its effect on the finances of the road and the floating debt, and deferred interest on bonds necessitated a receiver, June 1, 1894. The court appointed Judge E. B. Rosser and vice-president W. C. Hale in that capacity. The officers of the road are Dayton Hale, president; W. C. Hale, vice-president, and W. L. Seddon, secretary. G. W. Evans is superintendent and active manager of the plant.

The twenty miles of track controlled by the Atlantic Traction comprises a line to Fort McPherson, five miles southwest of the city from the down town district. It passes within a block of the corner of Marietta and Broad streets where all the lines of the consolidated company meet.

In the old Atlanta City line there are 10 miles of road and in the Atlanta Traction  $8\frac{1}{2}$ . The routes are four in

number, namely: Union Depot to Decatur, 8 miles; to East Lake, 2 miles; to Fort McPherson,  $6\frac{1}{4}$  miles, and to Grant Park,  $2\frac{1}{4}$  miles, making an exact total of  $18\frac{1}{2}$  miles of single track.

The road is similar to that of the Consolidated as regards paving, and the track consists almost entirely of 40-pound T rail excepting girder down town. It is single throughout with turnouts. The grades are considered the heaviest in the city and range from a few hundred feet to a quarter of a mile in length of from 4 to 8 per cent. The General Electric, Edison and Detroit overhead material may be seen on the line.

There are two power houses used to operate the system, the larger of which is placed at the corner of Glenn and Humphrey streets on the Fort McPherson line. Here also are the general offices of the company and the headquarters of Superintendent G. W. Evans. The plant consist of an engine room, 60 by 80 feet; a boiler room, 20 by 80 feet; a machine shop, 25 by 25 feet, and a car barn, 125 by 100 feet, with capacity for storing 25 cars. Here are two Russell engines, one of 280-horse-



EAST SIDE POWER-HOUSE—ATLANTA TRACTION.

power, 20 by 27 inches, with a double 10-foot fly wheel carrying a 19-inch belt. It is belted direct to two 110-kilowatt Eddy M. P. generators. The other is rated at 125-horse-power, 14 by 20 inches, with a 9-foot fly wheel of 18-inch face. It is belted direct by Munson belting to one 80-kilowatt Edison bi-polar machine. In the boiler room are two vertical McLaughlin boilers of 125-horse-power and one horizontal Russell boiler of the same capacity. A Wainwright feed-water heater, a Buffalo duplex pump,  $5\frac{1}{2}$  by  $3\frac{1}{4}$  by 6 inches, and a Dean pump of the same capacity complete the steam plant. The coal used is the run of the mine, which is landed at the door on the southern railroad tracks. The switch board is on the Edison plan, and contains three-line switches and four feeders. Three lines are run from this plant in separate sections. One Westinghouse lightning arrester, four made by Wason and one home made device protect the station from Jove's arrows. The home device consists of serrated carbon discs connected to

very light fuse wire, about a No. 25, and from thence to the ground. A Westinghouse circuit breaker is also in use satisfactorily. The line arresters consist of two Wasons and three Garton-Daniels.

In the machine shop, which adjoins the engine room, may be found a Barnes, of Rockford, Ill., drill, and a 12-inch lathe, made by Ames, of Chicago. One machinist and a helper are kept busy here making trolley wheels, springs, contacts and other small goods. The wheel castings are bought, and bored and turned in the shop. A  $2\frac{1}{2}$ -horse-power stationary motor keeps the wheels moving. In the car barn, one man is kept busy repairing and repainting cars. There are 20 cars in use in all, with 14 in use steadily. They were made by the American Car Company, of St. Louis, and by Brill. McGuire and Robinson trucks are under the cars. The motor equipment lines up six Spragues, 15-horse-power, two to each car; two Edisons of 30-horse-power, two to each car; four double 20-horse-power equipments; six Detroit of 30-horse-power, and two late editions of the Westinghouse double 25-horse-power equipments.

W. B. Weaver is chief accountant of the office, which occupies a corner of the building.

At the Irwin street power house, which is near the Southern Railroad tracks, two four-valve Russell engines, 14 by 20 inches, of 125-horse-power each, are belted direct by Munson belting to two 80-kilowatt Detroit generators. The fly wheels of the engines are 84 inches in diameter by 20-inch face, and turn at 180 r. p. m. The engine room is 35 by 40. The boiler room, which is 18 by 35 feet in size, contains two Walsh & Weidner boilers, made at Chattanooga, Tennessee. They are of the return tubular type, of 180-horse-power each, measuring 64 inches by 15 feet. Here, also, are one Berryman heater and purifier, one Snow pump and a Wason injector. Coal slack is burned at the rate of  $3\frac{1}{2}$  tons a day. On the fine little switch board may be found a Westinghouse circuit breaker, and Detroit ammeter. The average station load is 120 amperes on the two machines. The lightning arresters here are three in number, of the Wason type, and with three Garton-Daniels on the line. Three feeders run from this station, operating the Decatur and the East Lake and part of the main line.

H. J. Burnap, the station engineer, has the plant in fine condition. He has in the engine room an oil filter of his own design.

It is a galvanized iron tank, 4 feet high and 2 feet in diameter. On top is a screen which removes coarse refuse as the oil is poured in. Then comes a layer of charcoal, also on a screen. Next below is a pan of white waste, and below that another shallow pan of cheese cloth. The oil then settles to the funnel and through the spout into water ten inches deep. The oil rises level with the oil cock and is drained back for use. A water gauge shows the height of the water, which may be drawn off as often as necessary at the water cock.

The car barn, situated next the engine room, is 50 by 100 feet, with three tracks and a pit. It will hold eight cars. In the engine room is a coil of 50 feet of  $1\frac{1}{2}$  inc

hose. This Mr. Burnap has arranged ready to couple to the pump. The city pressure is eighty pounds, and by turning in his steam at eighty pounds, the pressure can of course be doubled. The station is neatly and intelligently kept.

The line does a good business and is materially aided by the resorts mentioned in this chapter and described elsewhere.

This line has the only transfer ticket used in Atlanta.

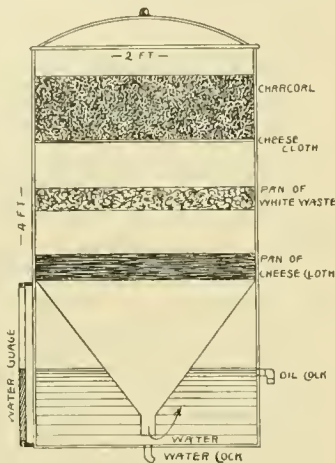

### THE ECONOMY OF HIGH SPEEDS.

Although the ultimate economy of quick schedules for getting the greatest possible mileage out of cars and men has been spoken of before in these columns, the importance of the subject deserves further mention. It is hardly necessary to reiterate the well known fact that the faster the schedule speed the greater the number of passengers that can be hauled with a given set of cars and men. To take an extreme case, suppose that on a certain round trip of five miles, which had previously been made in an hour, the time is shortened to thirty minutes, by virtue of less laying over time and increased speed. The result will be that it will take only one-half the previous number of cars to maintain the same frequency of service, or, on the other hand, the previous number of cars will give a headway one-half as long as before. Suppose that the headway is kept the same and one-half the cars are taken off. What is the result? The transportation expenses on that line are reduced one-half, the number of motor cars to be bought, inspected, housed and maintained is reduced one-half, and the public is given a much faster and more satisfactory service. But the superintendent may say that the increased speed means more power per car and greater wear and tear on cars and motors. Very true, but will these items overbalance the items before enumerated. In considering the power required, it must be remembered that only one-half the cars are on the road which were previously running. While the cars remaining will theoretically take more than twice as much current, the taking off of one-half the cars will very nearly balance this. In fact, it is a question whether any more power will be required for the faster service, as greater internal, electrical and mechanical losses would occur with the larger number of cars. Even if more power was needed, its cost will be small compared to the saving on trainmen's wages and other items classified as transportation expenses. The cost of power is usually only from 10 to 20 per cent of the entire operating expense, while the transportation

expenses are in the neighborhood of 50 per cent. The further objection to the fast schedule might be raised that it causes excessive wear on the cars and track. As far as the cars are concerned, it is safe to say that it costs less to inspect and maintain five cars making 150 miles a day each, than it does ten cars making 75 miles a day each. The mileage being the same in both cases, it is easier to handle the wear in the smaller number of cars. The wear on the track is so small as to need almost no mention. The only valid objection to the fast schedule is the danger from accidents. While this has some weight, it must be remembered that this is largely a matter of educating the public, and that experience has proved that after the first two or three months the number of accidents falls back to the usual amount. We have taken as a concrete example an extreme case, because it illustrates the principle so clearly. It must be remembered that laying over time at the ends of routes is simply a necessary evil, and does not pay dividends. It is good for nothing except to provide for the making up of lost time, and in some cases to preserve a ten, fifteen, twenty or thirty minute headway that can be easily remembered by the public. Another thing to be remembered is, that it is much easier both on power station and motors to have the motors arranged for a high maximum speed, enabling them to make schedule time without crowding too much in making starts than it is to have the maximum speed so slow that the motormen are obliged to strain them in starting.

See if you cannot quicken your schedule and give the public a more frequent service, thereby inducing traffic at a very little additional expense, or, on the other hand, give your patrons the same service with fewer cars. Raising the voltage to increase the speed may prove to be an advantage in this connection. Perhaps, also, you can put a field shunt on your motors.

Getting the fullest possible use of the apparatus and men you have is the way to pay good dividends. One of the secrets of the success of electricity from a financial standpoint is the increased mileage which can be obtained from a given number of cars and men.

THE transfer tickets which have engraved upon the face certain figures, popularly supposed to be representatives of the human form divine, are dangerous in one particular. At least, a conductor in a neighboring city had this experience: A lady who had seen several different presidents occupy the presidential chair, got into a car as it was leaving Blank street. Her dress was not according to the latest fashion plate, but was neat and well kept. When the conductor took her fare she asked for a transfer. The conductor looked her over and punched the picture of a spinster. She was on her feet in a moment and her tongue started at a rapid rate. The conductor's face presented all the colors of a spectrum while he hastily tore up the first transfer and presented her with another with the face of the modern young lady punched out. Then she subsided.



THE STREET RAILWAY MEN OF ATLANTA AND PROMINENT CITIZENS, MEMBERS OF THE LOCAL COMMITTEE OF ARRANGEMENTS.

The street railway men of Atlanta have been most heartily assisted in their multitudinous preparations for the convention by the enterprising citizens of the enterprising city, and we take pleasure in introducing here those gentlemen who are among the chosen, known as the "Local Committee." We feel sure this presentation will inspire a desire in the hearts of all our readers to meet and become acquainted with our Atlanta hosts.

JOEL HURT,

the president of the Atlanta Consolidated, and the prime mover in all that Atlanta has done for the Association,



JOEL HURT.

is a southern gentleman, and was born in Russell county, Alabama, in 1850. At the early age of 15 he was left without home or support, and worked his way through academy and college, until his graduation from the civil engineering course of the University of Georgia, in 1871. For ten years after the completion of his course he worked at his profession, mainly

in railroad work, on various southern lines. Since the year 1881 Mr. Hurt has been largely interested in real estate, and other large financial operations, in and about Atlanta. Mr. Hurt was the main force in the reorganization of the Consolidated, and to his constant work and unlimited patience and perseverance is due the present success of the system. Mr. Hurt is a handsome man of 44, with snow white hair and mustache, which give him a much older appearance. His operations in all fields of southern enterprise have been large and successful, and none more so than his Consolidated system.

ERNEST WOODRUFF,

the vice-president and general manager of the Atlanta Consolidated Street Railway Company, was born in 1863, at Columbus, Ga., where his early education was obtained. The first business experience of Mr. Woodruff, after leaving school days behind, was as a traveling salesman for a flourishing flouring mill. In this line of duty he was successful to an unusual degree. The cause of this success is patent to every acquaintance into whose experience the ready wit, sympathy and suavity of the gentleman has come. When the reorganization of the Atlanta Consolidated was made in 1891, Mr. Woodruff found himself in the board of management,



E. WOODRUFF.

which, in due course of time recognizes his ability and worth by making him vice president of the corporation and general manager of the property. Mr. Woodruff has been an untiring worker in advancing the interest of both Atlanta and the Consolidated Street Railway system.

He married an Atlanta lady, Miss Winship, and has been a resident of Atlanta since July, 1893. He is an Elk, a Mason, and in the directorate of the East Atlanta Land Company, the Trust Company of Georgia, as well as vice-president of the Consolidated.

SUPERINTENDENT H. N. HURT,

The representative of the Consolidated, upon whose broad shoulders comes the brunt of the daily miseries of street railway life, has neither lost his elegance and candor of manner, nor his faith in human nature, by reason of the trying position of superintendent. H. N. Hurt enjoys not only the confidence of the company and the respect of his employes, but the good will of every citizen of Atlanta, big or little, white or black.

He was born in Hurtsboro, Ala., in 1862, the only child of the family, His father died while the subject of this sketch was but an infant, so that cares and responsibilities fell early upon him. His widowed mother is still living. Young Hurt began active business life at 18, in a surveying party, and followed engineering as a profession until 1891, when he dropped general practice to become engineer for the then new Consolidated. The well-built and reputable track work of the most of the Consolidated's lines is of Mr. Hurt's construction. In 1892, he was made roadmaster, and in 1893, in recognition both of his engineering skill and his finesse in handling men, he was made superintendent of the whole system. Mr. Hurt's unfailing good nature, his charming comradery and his good will, have made for him many staunch friends throughout the south and north.



H. N. HURT.

THOMAS K. GLENN,

with the title of Mr. Joel Hurt's private secretary, assistant treasurer and secretary of the street railway, bears up bravely under 25 years of unmarried bliss. He was born in Vernon, Miss., in 1868, and received a common school education at Marietta, Newnan and Decatur, Ga., where he successively lived. He came to Atlanta in 1885, and entered the banking house of Maddox-Rucker, where he remained five years, and where he gained an

extensive and practical business education, so useful in his present triple capacity. Mr. Glenn is a remarkably bright young man, with plenty of energy and grit, and one of the hardest workers in the local committee.

WILLIAM H. GLENN,

the courteous assistant superintendent and purchasing agent of the Consolidated, is but 23 years of age. He was born in Cave Springs, Ga., and removed to Atlanta in 1883. He is a graduate of the Atlanta public schools and of the Georgia School of Technology, taking the full course in that excellent institution. Mr. Glenn has a brilliant future before him and an intense interest in street railway work, which he entered the next day after his graduation, in 1891. He has worked pretty well "all over the line," and is competent in more than one branch of practice.

WILLIAM W. KINGSTON,

the handsome and debonair representative of the Johnson

formal supervision of all Pennsylvania south to Florida, and it is safe to say that there is no better known or better liked supply man in the South than Mr. Kingston, whose acquaintance is as universal as his good nature. He is a loyal Atlantan, and proud of the beautiful city, which he calls the Chicago of the South. Assisting Mr. Kingston is a young Atlantan of unusual ability. His name is Eugene P. Thomas, and in his twenty years of life he has crowded a fine business experience. He is a graduate of the Atlanta High School and has been in Mr. Kingston's office two years, rising from the position of under clerk. Mr. Thomas has a wide and growing street railway acquaintance, and a brilliant future is his chosen field.

JAMES W. ENGLISH, JR.,

of the local committee, is one of the most prominent society men and business powers in Atlanta. He was born June 11, 1867, in Georgia, and is a graduate of the Atlanta High School. He also took the mechanical



T. K. GLENN.



W. H. GLENN.



W. W. KINGSTON.



E. THOMAS.

Company, of Johnstown, Pa., for the South, has an elegant suite of offices at 437-437½ Equitable building. As an Irish friend of his once said, he is not only a "rile gintleman but a rail gintleman," and to his earnest efforts the visiting brethren will owe much of the hearty welcome that will be accorded to them. Mr. Kingston was born in Philadelphia in 1866, and attended and was graduated from Germantown Academy. In 1879 he entered the Pennsylvania Railroad service in the general freight department, where his ability was soon recognized and his discretion honored by his appointment as special rate clerk, issuing all special rates made by the Pennsylvania Railroad Company. In 1890 he was induced to join the Johnson Company contingent in the Philadelphia office, and in 1892 was made southern agent at Atlanta. He covers a wide territory between North Carolina and Texas, with a

engineering course of the Massachusetts Institute of Technology. For five years he was a railroad contractor, and built many miles of line in his native state. He is at present manager of the Chattahoochee Brick Company, one of the largest concerns in the country. During 1890-91 he was president of the Atlanta Traction Company, but sold out these interests some time before the receivership. Mr. English is a trustee of the magnificent Grady Hospital, and is officially connected with several other important affairs in Atlanta, of which city he is a loyal and enterprising son, a man of large resources and abundant pluck.



JAMES W. ENGLISH, JR.

DR. C. D. HURT,

one of the most prominent of southern physicians, is surgeon for the Atlanta Consolidated, and a brother of President Joel Hurt. He is an Alabama man by birth, and served as a non-commissioned artillery

officer in the Confederate army until 1865, with distinction. He then graduated in medicine, and practiced both at Hurtsboro and Columbus, Ala., with great success. He came to Atlanta in 1892, and stepped into a fine practice which his wide reputation had provided him in advance. He is vice-president of the Atlanta Society of Medicine and of the Atlanta Gynecological Society. Dr. Hurt has a wide repute among the southern practitioners both in medicine and surgery.

CAPTAIN HENRY JACKSON.

This well known lawyer, capitalist and distinguished legal writer was born in Savannah in 1845, of a long line of ancestry famed in revolutionary history and political preferment. He was educated in England while his father was United States Minister to Austria. When war was declared between the states, Captain Jackson entered the confederate army and served with distinction on the staff of Gen. Stonewall Jackson and later became

ceded to be one of the best read lawyers in the south and enjoys a lucrative practice. His engaging personality and his high social position give him great weight in all public affairs. He is a Capital City Club man and a U. of Va. Delta Psi, as well as a director in the Atlanta Consolidated, and attorney for the Nashville, Chattanooga & St. Louis Railroad.

R. J. LOWRY.

One of the most public spirited of Atlanta's wealthy men is R. J. Lowry, who combines the offices of president of the Lowry Banking Company, president of the Atlanta Home Insurance Company, and the Georgia Trust Company; member of the board of directors of half a dozen corporations which are helping to build up Atlanta, and director of the Atlanta Consolidated Street Railway Company. He served in the city council in 1871, and was a prime mover in establishing the present splendid public school system. In 1881, as alderman again, he helped to estab-



J. CARROLL PAYNE.



DR. HURT.



R. J. LOWRY.

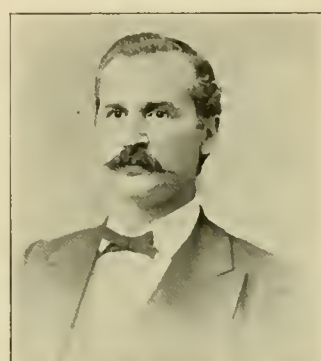

CAPT. HENRY JACKSON.

Adjutant General of Colquitt's brigade. After the war he entered the University of Georgia law school and was graduated with honors in 1866. He came to Atlanta in 1868 and has since practiced law, but has found time to write upon legal lore, edited and published Georgia Reports, volumes 45 to 66. He has been counsel for several railroads and is at present counsel of the Southern System. He is president of the great Suwanee Canal Company, a director in several other corporations, including the Atlanta Consolidated Street Railway.

J. CARROLL PAYNE,

a leading jurist of Georgia, is a Virginian by birth. He was graduated from Georgetown College and studied law at the University of Virginia. In 1876 he removed to New Orleans, La., and again graduated in civil law, which is the practice in that state. In 1885 he married Miss Hill, of Georgia, and removed with his bride to Atlanta in 1885. Mr. Payne is con-

lish the fine paid fire department, of which the city is justly proud. In all that tends to build up or advertise Atlanta, Mr. Lowry is willing to help, and the American Street Railway Association meeting is no exception to this rule.



MAJOR LIVINGSTONE MIMS.

Major Livingston Mims, is all that can be expected of a leader of society and business life in the foremost city of the southeast. No public function is complete without his dignified presence, and no enterprise can afford to forego his ready sympathy and efficient help. Major Mims came to Atlanta from North Carolina in 1876. He is district manager of two large insurance companies and president of the Capital City Club. On his recent retirement from the presidency of the South Eastern Tariff Association, the underwriters presented him with a \$3,000 silver service. Major Mims absolutely refuses political preferment and is a modest and thoroughly popular gentleman.

W. L. SEDDON,

of the local committee, was born in Virginia in 1861, where he spent his boyhood. He was graduated civil engineer in 1880, from the University of Mo., and practiced six years in government work. He spent three years in electrical work in St. Louis, and planned the once



W. L. SEDDON.



N. W. L. BROWN.

famous Lindell storage battery scheme. In 1885 he went into the street railway business in Kansas, where he gained much experience. In 1890 he came to Atlanta and helped build the Tracton Company's line, of which he was vice-president and secretary. Mr. Seddon is still hopeful that the line will be reclaimed and put upon a paying basis.

N. W. L. BROWN,

road master of the Consolidated and acquainted with grief as the chairman of the committee on exhibits, has distinguished himself in both capacities. He was born in '68 in Alabama, and entered a surveying party after completing the work of the village academy. He worked in railroad civil engineering in Tennessee, Alabama, Mississippi and Georgia. In 1888 he entered the Rennsalaer Polytechnic Institute and was graduated C. E. two years later. In 1892 he took the students course at Lynn. in the Westinghouse shops and in 1893 came to Atlanta as road master. Mr. Brown is a thorough street railroad man of great enthusiasm and a competent manager in almost any line of work.

R. D. BULLEN,

assistant manager of the Atlanta office of the General Electric Company, was born in Wakefield, Mass., in 1864,

and was educated at Providence and Pawtucket, R. I., graduating at Brown University. He is a Phi Beta Kappa, and has attained a master's degree. In 1887 he went into electrical work, constructing for the Thomson-Houston Company, and a year later was detailed to the southern office

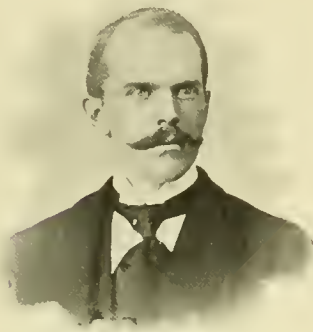

R. D. BULLEN

when he was made head of the supply department. Mr. Bullen is now assistant general manager and the southern office owes much to his efficiency.

S. W. TRAWICK,

is general sales agent for the General Electric Company. He was born in Hawkinsville, Ga., in 1862. He graduated at the town high school and went into the banking business in 1881 at Wellsville, N. Y. In 1888 he went to Chicago with the Excelsior Electric Company, and two years later associated himself with the Westinghouse Company at its St. Louis office. Later he became special agent for the Brush Company at Atlanta, and was transferred to the General Electric Company in 1893, when two Atlanta offices were consolidated.



S. W. TRAWICK.

J. H. ALLEN,

the affable and enterprising manager of Dixie, the great commercial organ of Georgia and the southeast, is a hard working member of the local committee. His office is in the Equitable building, and the gentlemen in charge will be glad to see all the visiting members, street railway men, supply men and newspaper men. Just a glance at Mr. Allen's countenance is assurance



J. H. ALLEN.

that those who may visit his office will find the door open, and that a hospitable welcome awaits within.

THOMAS B. FELDER,

for the year 1893-4 president of the Atlanta Traction Company and a prominent and efficient member of the local committee, was born in 1863, in Burke county, Ga., and was graduated from the Waynesboro High School in 1879 with honors. After attending college at Dahlonga, he graduated from the law department of the University of Georgia in 1883. Mr. Felder has held several important political positions with great honor and credit, and is at present engaged in law practice in Atlanta with great success.



T. B. FELDER, JR.

A glance at Mr. Felder's record shows that he is remarkably bright, having become a full fledged disciple of Blackstone at the age of 20 years. No doubt his progress in his profession has been more rapid than his acquisition of knowledge during his school days, and this accounts for his prominence.

WALTER M. KELLEY,

the wide awake and progressive agent of the Carnegie Steel Company at Atlanta, came from the Pittsburg office three years ago. His office is in the Gould building, and his operations over a wide territory, where he is well known. He has been an active worker for the entertainment of the association. He is a member of the Capital City Club.

S. M. INMAN,

the large cotton dealer, is a director of the street railway. He is fifty years of age, an East Tennessean by birth, and was graduated from Princeton college. He is interested in every good work in Atlanta.

ARTHUR F. GILES.

The brilliant young manager of the southern office of the General Electric Company may ordinarily be found hard at work in room 431 of the Equitable building. He was born in 1871, in Boston, and, after a through Boston



W. M. KELLEY.



S. M. INMAN.



A. F. GILES.

public-school education, went into the Boston office of the Thomson-Houston Company. This was in 1888. With this organization Mr. Giles was sent South in 1891 as auditor of the Thomson-Houston's Atlanta office, and retained the same position under the General Electric Company. In February, 1894, Mr. Giles took general charge of the office, and recent good contracts of the General Electric in the South attest to his sagacity and energy.

DAYTON HALE,

receiver and president of the Atlanta Traction Company, was born in Mississippi in 1849, and received a common-school education. He has been a large manufacturer of saddle blankets, woolen and cotton goods, and was for eight years postmaster at Columbus, Miss. He came to Atlanta in 1893. His colleague is Judge Rosser.

JUDGE E. B. ROSSER,

has been a prominent man in Georgia politics and was a member of the constitutional convention, as well as a judge of the county court for a number of years. He is 56 years of age and a native of Georgia.

He has been largely interested in cotton.

THOMAS ELLIOTT,

the efficient station engineer of the Atlanta Consolidated, and the inventor of the devices credited to him, is an Englishman, having been born in Durham County, in 1863. With few advantages beyond a common school education, young Elliott entered the employ of the great steel firm of Balchow, Vaughan & Company, in the engineering department, where he received an admirable training. In 1882, he came to America and worked successively for Coxe Brothers & Co., of Drifton, Pa., the



THOMAS ELLIOTT.

Lehigh Valley Railroad, the South Brookside Cotton Mills, of Knoxville, Tenn., and with Manager M. R. McAdoo, of the Paterson, N. J., Street Railway. In all cases he was mechanical engineer or master mechanic,

and when, in 1891, he went with the Atlanta Consolidated, he brought to his work a wide experience and thorough training in detail, as well as an active and progressive mind.

## WHAT JUST DESERTS!

The Washington, Pa., Observer, observes as follows: "The city of West Chester wanted the earth to permit the trolley line from Lancaster to Philadelphia to run through its streets, and the trolley company people side tracked West Chester by running around it. Some people think this is a good way to treat West Chester."

There are several other one horse towns in this country that need the example of West Chester.

THE brainy New York Sun has discovered that "The introduction of the cable cars has led to the weeding out of the old and sickly horses of the street car lines, and the superintendents of the big stables have learned that it is better to have frequent relays for their horses and keep their stock in good condition rather than save the wages of a few extra men at the expense of the horses."

## HARRY C. SIMPSON.

The general manager of the St. Louis Register Company, in the New York office of that flourishing concern, is Harry C. Simpson. Perhaps no one of the supply men in the street railway business has entered on life with any more obstacles and surely no one so been more markedly successful in overcoming all difficulties.

Mr. Simpson was born in Philadelphia, in 1847, and gained his knowledge of reading and writing from his mother. He never attended any school, but went to work at eleven years of age as errand boy, on one dollar a week. He filled various positions until his twenty-first year, when he went to New Orleans to engage in business. Yellow fever attacked him here, and on recovery he found his health shattered. A sea voyage was determined on, and, when his funds were spent, he worked his passage. He visited almost every coast country in the world, and returned to America after thirteen months of sea life, in restored health. After a brief experience in the theatrical business and other ventures, during which time he traveled in Europe, he engaged with the well-known firm of Lewis & Fowler, of Brooklyn, handling their fare register. The business prospered and the Lewis & Fowler Manufacturing Company was formed, with Mr. Simpson as secretary, which position he resigned to become contracting agent for Pullman's street cars. Not satisfied with his treatment by this company, he went to South America, engaging in the manufacture of street car springs. This was an unfortunate venture, and he returned to the Lewis & Fowler Company as Pacific coast agent. Finally, a flattering offer from the St. Louis Register Company made him general manager in a short time, which is his present position. Mr Simpson's career has been one of honor and success, and a large circle of friends and business acquaintances appreciate his sterling worth and ability.



H. C. SIMPSON.

LARGEST ORDER EVER PLACED FOR  
ELECTRIC CAR HEATERS.

That electric car heating has taken a firm hold in New England, where Nor'easters are about as penetrating and cold as any winter wind the land over, is evidenced by the placing on September 12 of the largest order ever given for electric car heaters.

The road whose patrons are thus to enjoy the genial warmth of the unseen force, is the Union Railroad of Providence, R. I., the extensive system of which includes about one hundred miles of tracks. The cities and towns connected by this line are: Providence, Pawtucket, Coventry, Cranston, Cumberland, East Providence, Johnston, Lincoln, North Providence, and Warwick.

The Consolidated Car Heating Company, of Albany, N. Y., was the fortunate one selected to furnish and install this extensive equipment, and will proceed to do so with the utmost dispatch. The facilities for turning out work will enable the company to fill the order promptly.

That electric heating is making much more rapid progress than has been fully realized by many, is seen in the statement, that fully 60 roads are now equipped and will use this winter, the electric heaters of the Consolidated Electric Heating Company, and managers who have not already adopted this method, will have ample opportunity to fully investigate the heaters, which will be exhibited at the Atlanta convention.

## ANOTHER AERIAL ROPEWAY.

A company of reliable men has been formed in England to operate an aerial ropeway at Brighton Dyke. The ropeway, which is the middle link of the system of transportation to be built, is to have three spans. The longest or middle span is to be 650 feet. The cables upon which the cars will run are to be suspended from a supporting cable, so that it is possible to keep the car cables almost level. The cars will pass through openings in the towers supporting the spans, so that the whole length of the road (1,250 feet) will be made without interruption. The termini of the aerial road will be approached at each end by cable roads.

## KEEP THE TROLLEY ON THE WIRE.

BY EDGAR THORNE.



MOTOR car stood "lifeless" in the middle of the street,

And all its twenty passengers had risen to their feet  
One said a "fuse" had burned away, with elongated face,

Another that a "plug" was blown out of its proper place,

And all agreed they'd be delayed at least one tedious hour,

Before they could go forward and regain the absent "power."  
At last a modest little maid, whom none could but admire,  
Exclaimed, "I'll tell you what it is—the trolley's off the wire."

In household matters, love affairs, in monetary things,  
If happiness escapes you upon quick departing wings,  
Don't worry, flurry, fuss and fret, but keep your temper down,  
Nor let your placid brow be marred by wrinkle or a frown;  
When friends desert and enemies with hate would pierce you through,  
And everything perplexes, and you don't know what to do,  
Don't be discouraged or dismayed, nor from the world retire,  
But ask yourself this question: Is the trolley on the wire?

In any situation, though you be with sorrow clad,  
Don't be of doleful countenance and to your troubles add,  
Maintain a constant equipoise and peaceful frame of mind,  
And cast anxiety and care out to the fickle wind.  
In all the hurly-burly of this rough-and-tumble world,  
Though at him shafts of malice were unscrupulously hurled,  
I never knew a man to fail who had ambition's fire,  
And kept, with strong and steady hand, the trolley on the wire.  
—Congregationalist.

THE contract for the track of the Columbia Railway cable line, at Washington, D. C., was let to E. Saxton.

THE PALATIAL ARAGON.

Official Headquarters Hotel, American Street Railway Association.

The most elegant and modern of southern hotels is situated at the corner of Peachtree and Ellis streets in Atlanta, just within the business portion of the city and within five minutes' walk of any given business office or shop. At the same time it fronts on the finest residence thoroughfare in Atlanta, and within a stone's throw of the Capital City Club, the Governor's mansion, and dwelling place of Georgia's elite. The house was opened but recently, yet has already gained a wide clientele. It is conducted on both the American and European plan by Charles F. Dodge, a past master of hotel management of Chicago, New York, and southern experience.

The building is six stories high, with a roof garden of elegant design. The style of the building is Spanish romanesque, and marble; pressed brick and terra cotta enter into its composition. The first story is of Georgia marble, and the other five of pressed brick and terra cotta, with marble trimmings.

The main entrance, on Peachtree street, leads into the marble-floored main office, which is cabinet finished and equipped with the usual desk and manager's office. Here the visitor will be greeted either by Manager Dodge, or clerks D. J. Gracey and Oliver Johnson. Mr. Dodge is a hotel man of many years' experience, both in New York and Chicago, while Messrs. Gracey and Johnson are the most affable and courteous of gentlemen, with a large acquaintance among the traveling public.

At the right of the main entrance is the gentlemen's smoking, reading and writing room looking out on Peachtree street through a French plate-glass front. Here may be found the telephone, telegraph and cab offices. At the left of the main entrance is the ladies' entrance and reception room. The latter is furnished in exquisite taste. Near this room is the elevator shaft, and to the left, the restaurant and cafe. This room is 40 by 70 feet, and has connection with private dining rooms

and the breakfast room. The cafe, a view of which we show, is fashioned and appointed as nearly as possible like the Holland House restaurant, New York. It is draped with velour and laces and tropical plants adorn the windows. The silver and china is elegant, as befits the product of Gorham and Haviland. The service is most efficient and the ensemble touches the æsthetic gourmand in several places. While speaking of the dining room, it may be well to mention that the table is provided with every delicacy of the season, and what

the region within a night's ride of Atlanta cannot furnish could be listed in a small space. The sea shore and the semi-tropics of the Gulf, the warm climate of middle Georgia and the moderate temperature of the highlands, give to the epicure all the wealth of water, air and earth in season. Breakfast and an elaborate luncheon, with dinner from 6 to 8, will be found a recurring pleasure. The breakfast room and private dining rooms are of equal elegance and taste.

The buffet, bar, and billiard room, to the rear of the office, have an air of greatest refinement and taste, as well as the best the market affords. On stepping from the elevator on the second floor the guest is attracted by an

open court, in which a fountain plays amid a bower of tropical plants. Here is also the main dining room, 40x60 feet, finished in quartered oak with two elliptic windows, thirty feet each, making one end entirely glass. The ceiling is paneled with oak beams, and on either side of the room are fire places and side boards. The handsome chandeliers and parquetry floors and the vine entwined pillars make it an ideal ball room on occasion.

The numerous parlors are elegantly furnished with costly draperies, bric-a-brac, portieres, inlaid tables and richly upholstered chairs and couches. One suite is in gold and ebony, another semi-colonial, with white and gold, and all have rich paintings and frescoed ceilings. The bridal chamber is a lovely piece of the decorator's



THE ARAGON—HEADQUARTER'S HOTEL.

art, with a grand piano and electric chandelier. Many of the best known supply houses have already secured headquarters in the parlors, and others will follow before the end of the month.

The rooms are uniformly excellent, single and en suite, ranging in size from 10 by 12 to 20 by 26. They are finished in natural wood, and provided with gas and electric light, steam heat and call bells. The decorations are tasteful, and neither too numerous nor too few. A recently added annex, furnished and finished in the same style as that described, will give ample accommodation to all comers.

The kitchen, store room, laundry, and other working departments are in a separate building, as is also the special electric light plant, of the General Electric's installation. The sanitary arrangements are the best and the steam heating system well nigh perfect. The entire building is practically fireproof, but fire escapes are also provided, as an additional guarantee of safety. On the roof is instituted a summer garden that has been most pleasant to visitors and profitable to the management. From its peak may be seen Kenesaw Mountain, Lone Mountain, and the Stone Mountain, mentioned elsewhere in this issue. During the warm season concerts are held here each evening, for guests and such of the towns people as are possessed of season tickets.

Among the minor conveniences is a special free omnibus, that meets guests at the Union depot; the best of

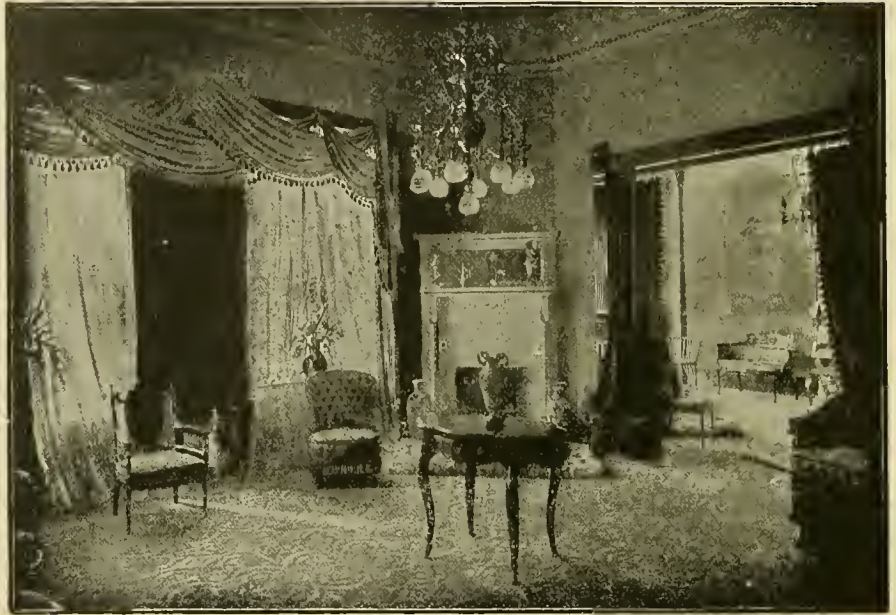

THE ARAGON—PARLOR A.

porter service in moving baggage and exhibits, and prompt attendance to calls.

The committee has made no mistake in selecting the Aragon as headquarters of the Association, from the point of view of its excellence as an inn, as well as from the fact of its convenient location. All the electric cars to Piedmont Park pass the door, and three blocks away stands the Equitable building, the electrical center of the city.

#### THOUGHT HE WAS A DUMMY.

A distressing accident occurred on the San Francisco & San Mateo Electric Railway recently. It seems that mischievous boys have been in the habit of placing straw men on the street railway track and watching the frantic efforts of the motormen to stop the car and avoid running over the dummy. On the occasion alluded to, a motorman ran into and killed a drunken fellow who was lying across the rails, thinking it was a dummy. The motorman was arrested, but released on his own recognizance. It seems to us that the arrest of the boys and their punishment is now in order.

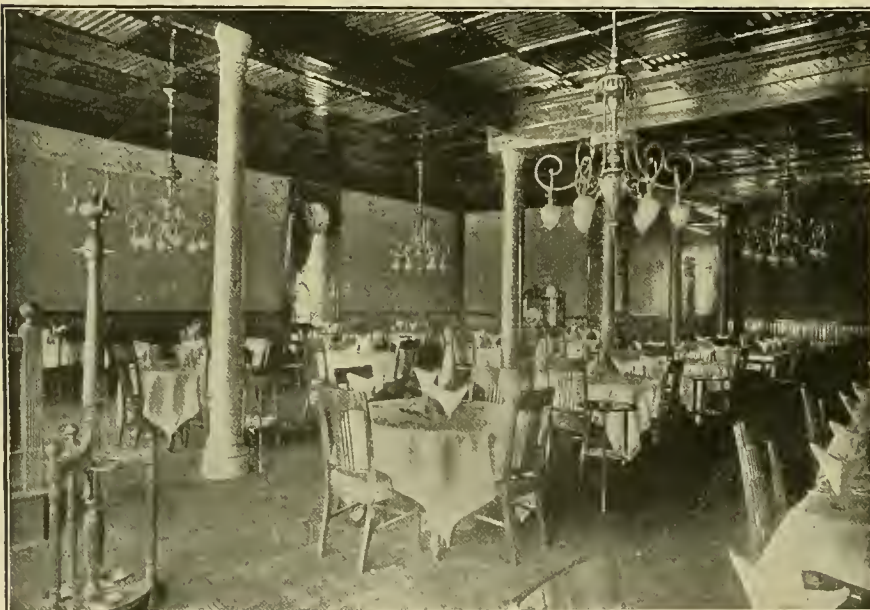

THE ARAGON—CAFE.

JACK T. ADAMS, of Atlanta, is doing a large detective business for southern street railways. He has the confidence of the roads which employ his men, and has acquired a wide circuit that he "works" regularly.



## HOW TO PREVENT ELECTROLYSIS.

And Make a Complete Metallic Circuit for Electric Railways.

BY H. R. KEITHLEY.

The one problem of paramount importance in electric railway engineering, and one which has for the past two years received the careful attention of the foremost electrical engineers and electric railway managers, is the problem of preventing electrolysis, and the destruction of water pipes, gas pipes and underground electric cables of cities and towns, which is caused by the electrolytic action of the heavy underground currents of electric railways. It is now generally accepted by the ablest electrical engineers, who have given the problem the practical, experimental and scientific investigation which its importance demands, that the most practical, feasible and permanent solution of the problem is to provide a "complete metallic circuit for electric railways," and to abandon, as far as possible, the "earth return." Up to a period within the past two years, the universal practice in electric railway construction, has been to rely principally upon the "earth" to complete the circuit from the cars in operation on the road, to the power house, the bonding of the rails being considered of so little importance that only the crudest forms of No. 4 iron or copper bonds were used. In the early stages of the electric railway, the expert electrician made his estimates and calculations with the utmost accuracy and scientific precision for the overhead half of the electric railway circuit, and spared neither money, time, labor, copper, or "midnight oil," to bring the overhead half of the circuit up to the highest standard of construction. But the practical results which he aimed to obtain, viz: a low percentage of loss or drop on the line, and economical consumption of coal at the power house, were seldom, if ever, realized, and all of his elaborate calculation and supposed accurate estimates came to naught, simply because he trusted to Mother Earth and good luck to complete the other half of the railway circuit, and neglected to complete the metallic circuit by utilizing the abundance of metal in the rails, by properly bonding them together at the joints. This neglect has brought about the disastrous results of electrolysis of gas and water pipes and underground cables, and the high percentage of loss of power on the line, and enormous consumption of coal, has set at naught the supposed high standard of engineering perfection aimed at (but missed) in the overhead construction.

To complete the metallic circuit of electric railways by utilizing the abundance of metal in the rails, is simply a question of the application of just as much care and just as much skilled labor, and the same scientific accuracy in construction by bonding the rails properly, that is given to the overhead half of the circuit. For the rails are the other half of one continuous circuit, and unless each half of the circuit receives the same careful work of the engineer and the skilled workman in its construction, the

practical results obtained in the completed, or whole circuit, will exactly correspond to the inefficient work of construction on either half of the circuit, and it does not matter which half receives the inefficient work, the result will be just as disastrous in the end.

To utilize the metal of the rails for completing the metallic circuit is simply a question of properly bonding the rails. And to properly bond the rails is simply for the engineer to select the most perfect rail-bond in the market—both electrical and mechanical perfection should be combined—and to employ skillful workmen to do the bonding, and have accurate and uniformly drilled holes in the rail for applying the bonds; and last but not least, to distribute the rail bonds on the different lines of a railway system by making accurate estimates for the number and size of the rail bonds used at the joints, so that the total cross sectional area of the rail bonds will exceed the cross sectional area of the overhead half of the circuit at any given point on the line of the railway.

The careful observation of these principles in the construction of a complete metallic circuit for electric railways, will produce the desired results and prevent electrolysis of gas and water pipes and electric cables, reduce the percentage of loss of current on the line, and result in a great saving in the consumption of coal, for this is the inevitable deduction from the well established law, that electric currents follow the path of lowest resistance, and with the thorough system of bonding above described, the rails will be the path of lowest resistance and the amount of current which would leave the rails, thus heavily bonded, to follow gas or water pipes, or lead cables, would be so small that electrolysis would be reduced to a minimum, and all corrosion of pipes at the joints or elsewhere, be prevented.

The problem is now narrowed down to the selection of a rail-bond for making the most complete and perfect metallic circuit of the rails. For there is an abundance of metal in the rails of any road for the construction of a complete metallic circuit, if they can only be perfectly bonded together. For four 70 lb. rails of a double track railway, if bonded so as to utilize all of the metal, will have conductivity equivalent to that of four solid copper conductors, each one inch in diameter; and this amount of copper is rarely ever strung for a great distance over a line of railway. Hence it is obvious that the construction of a "complete metallic circuit for electric railways" is purely a problem of distribution of copper, and the use of the most perfect rail-bond, designed for both electrical and mechanical perfection, and thorough work in construction. The requirements of a rail-bond, designed for both electrical and mechanical perfection, are: first, a one-piece rail-bond; second, absolutely solid and perfect contact of the metallic surfaces in the connection between the bond wire and the rail; third, a rail-bond having its terminals enlarged in diameter at least 1.9 times the diameter of the bond wire itself. This provides for an area of surface contact in the connection equivalent to seven times the cross sectional area of the bond wire itself. This ratio of 7.1 is

required to overcome all electrical resistance in the connection between the two metals, iron and copper, the ratio of the resistance of iron and copper being as 7 is to 1. The mechanical requirements are that the design and structure of the rail-bond shall be such that it cannot be broken or have its connection with the rail broken loose by the vibration of the rail-joint caused by heavy traffic.

The types of rail-bonds now in general use need only be described to determine whether they come up to this standard.

1. The Rivet Bond. It is composed of a piece of wire soldered to a rivet on each of its ends. Its fatal defects are, first, it will corrode and break loose at the point where it is soldered to the rivet. Second, these soldered connections with the rivet, introduce resistance which limits the conductivity of the bond to that of the soldered connection, and since the current is forced through three hundred and fifty-two of these soldered connections in a mile of rail, the resistance must be very

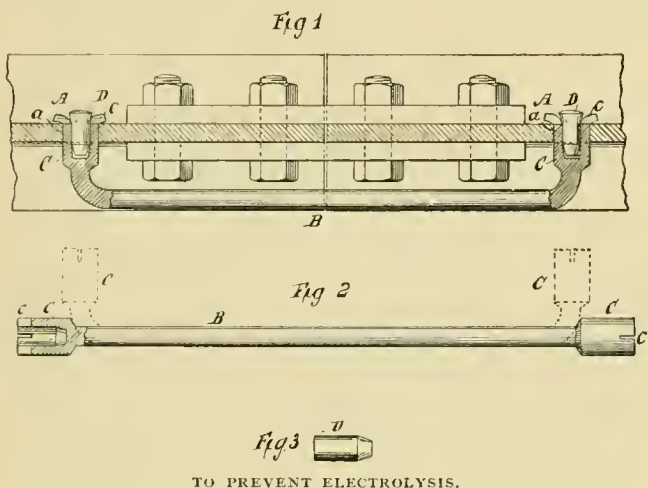

great, thus limiting the conductivity of a No. 0 rivet bond to about that of a No. 4 solid copper wire. Third, a riveted connection with the rail is nearly always imperfect in its contact of the metallic surfaces in the connection. From this it is evident that nearly two-thirds of the copper in rivet bonds is an absolute waste, for no matter how large the wire is, the conductivity of the bond is limited by the soldered connection.

2. The Channel Pin Bond. This is a piece of copper wire having each of its ends secured directly into the rail by iron channel pins. The defects are: The surface contact of the wire in the connection in the rail is always imperfect, and admits moisture, rust and corrosion, causing great resistance to the passage of the electric current, and eventually causing electrolytic action which destroys the connection. The area of the surface contact in the connection is very little more than the cross section of the wire. These defects make the resistance of three hundred and fifty-two such connections per mile of rail very great.

3. The One-Piece Rivet Bond, which consists of a wire having shoulders upset on each end, and is secured to the rails by having its ends riveted into them. This

is an improvement on the old style three-piece rivet bond, but is subject to the same defects, caused by the impossibility of making perfect metallic contact between the surfaces of a riveted connection; also the defect of having its terminals very little, if any larger, than the wire itself, making the area of surface contact in the connection very little greater than the cross section of the wire, whereas, it should be seven times the cross section of the wire. Hence, a large proportion of the copper in this rail-bond is a total waste, for its conductivity is limited by the conductivity of the connection with the rail. And, as there are three hundred and fifty-two of these imperfect connections to a mile of single rail, the resistance is correspondingly great.

The only rail-bond in the market which fulfills all the requirements of a perfect rail-bond, is the rail-bond having large tubular terminals, and which is secured to the rail by the means of drift pins. This is practically a one-piece rail-bond, having large tubular terminals, which are connected into a rail by inserting them into holes drilled to fit them, and permanently expanding such tubular terminals by stretching or swaging of the metal composing them into contact with the holes. This expansion of the terminals is accomplished by driving drift pins into them, said pins being about  $\frac{1}{16}$  of an inch larger than the openings in the tubular terminals. This makes an absolutely perfect and solid contact between the two metallic surfaces, in the connection, and permanently excludes all air and moisture, and renders corrosion or electrolytic action in the connection absolutely impossible, and makes a connection which will remain perfect as long as the bond wire or rail will last. The tubular terminals are 1.9 times as large in diameter as the bond. This gives an area of surface contact, in the connection with the rail, equivalent to seven times the cross section of the bond, and eliminates all electrical resistance from the connection. A single line of rail, carefully bonded with No. 0000 rail-bond, having these tubular terminals, will have its conductivity made equivalent to that of a No. 0000 solid copper wire of the same length. Therefore, this bond utilizes every particle of copper composing it for conductivity, and makes it possible to utilize any amount of metal in the rails required, according to the number and size of the bonds used to a rail joint.

It is a clearly established law of electrical conductors that the carrying capacity of a conductor is limited by the amount of resistance of any one part of that conductor. Then it is clearly evident that the conductivity of the four rails of a double track railway, double-bonded at each joint with No. 0000 bonds having tubular terminals, will be equivalent to the conductivity of 8 No. 0000 solid copper wires, of an equal length, if the rail-bonds are perfect, according to the standard above given, and all the connections are perfectly made. But this is too high a standard of perfection to be obtained in practice, on account of careless work in applying the bonds. But with ordinary care in bonding, and by bonding with cross wires across the track every four or six rail lengths, the four rails can be so bonded, with the tubular

terminal bond, that their conductivity will be equivalent to that of seven solid copper wires, of the same size of the bond, and the same length of the tracks so bonded. This is equivalent to a copper conductor of 1,481,200 circular mils. Only about one-tenth as much copper is required for making a complete metallic circuit by this system of bonding as would be required for a complete metallic circuit, completed by solid copper conductors, or "track feeders," as they are called. Therefore, it is evident that a complete metallic circuit of high conductivity can be constructed at far less expense for first cost of copper and construction by thoroughly bonding the rails with the tubular terminal rail-bond, referring to the principles above laid down.

The above described rail-bond and system of bonding has lately been adopted as the standard for all construction by the three great street railway systems of Chicago, on 450 miles of electric lines now under construction, and is rapidly being adopted by the various leading electric railway systems throughout the United States. It is popularly known as the "Chicago" rail-bond.

GRIPPING CABLES BY COMPRESSED AIR.

A novel but effective use has been made of the Genett air brake system on the cable cars of the Third avenue road, New York, the cars on which, have for some time been so successfully equipped with the Genett air brake. As the cars are double truck and quite heavy, consider-

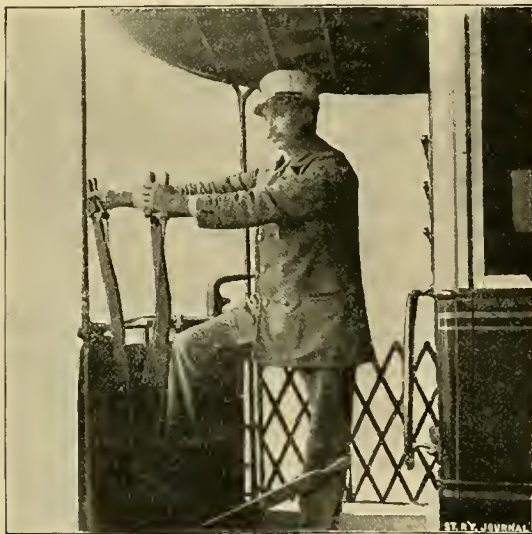

THE OLD WAY.

able strength was necessary to close the grip on the cable. With a view to decreasing the labor and increase efficiency, the company have fitted up one car with a mechanical device actuated by compressed air, from the same reservoir that supplies the brakes, and by this means make the position of gripman a very easy one so far as manual labor is concerned. Instead of the grip and brake levers in use on other cable lines, there are instead two small handles, one for use at the termini of

lines and the other with which practically all the work is done. This controlling handle has three positions, one for each of the following conditions: Grip closed with brake off; grip open with brake on, and grip open with brake released, this latter being used in descending grades by gravity. The experiment is working satisfactorily



THE NEW WAY.

and opens up quite a new feature in the equipment of cable cars, as the saving in strength enables the driver better to attend to other duties, and the rapidity and efficiency with which the grip takes the rope effects a marked saving in time and contributes to ease in starting train. Our illustrations show the car "before and after taking" air.

THE TROLLEY CAR MAN.

What a wonderful being 's the trolley car man,  
Of course we all know his worth,  
For do we not see him, each day of our lives,  
As we go up and down on the earth.

CHORUS.

"Yes, ma'am, this car's for down town,"  
"Fare please"—"Let me help you Miss."  
"Get out you young blackguard, I say,"  
"Oh ain't a conductor's job bliss."

Its a part of his calling to be well dressed and neat,  
And polite and attentive to all,  
And if you but give him the least little sign,  
He's sure to respond to your call.

CHORUS.

He has eyes like the lynx, but kindly and true.  
His grasp, it is firm and assuring,  
He always looks after the aged and weak  
With the young and thoughtless enduring.

CHORUS.

He is out on the streets, in sunshine and storm,  
He'll be found at his post in all seasons,  
He is ready to answer all questions they ask,  
No matter how foolish their reasons.

CHORUS.

--A Optimist.

### SOME NEW CREAGHEAD FLEXIBLE POLE BRACKETS.

The Creaghead flexible brackets for wooden poles, which we illustrated some time ago, have proved very satisfactory, especially on high speed interurban service, so that other standard types have been brought out by

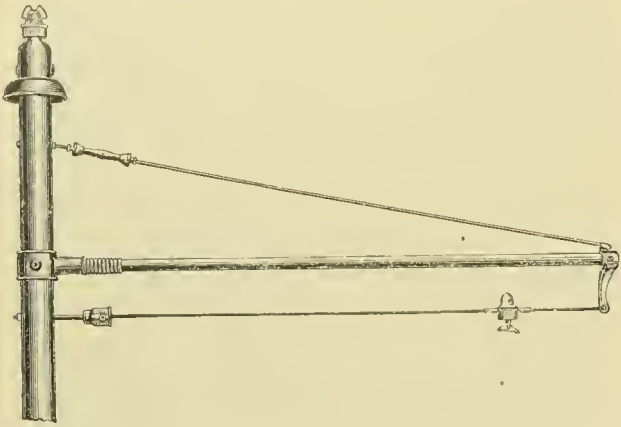

the company. Those herewith illustrated are the designs for single and double track with iron poles. They are insulated from the pole so that there is double insulation between the wire and the pole. There is an insulated turnbuckle in the top guy rod and a hard wood corrugated plug in the horizontal arm, while the span wire passes through an insulating bushing in the pole. The great need of more flexibility with bracket construction has made this design of pole bracket very popular. The Creaghead Engineering Company has recently equipped throughout, the Cincinnati & South Covington Street Railway's Evergreen line, using a large number of double

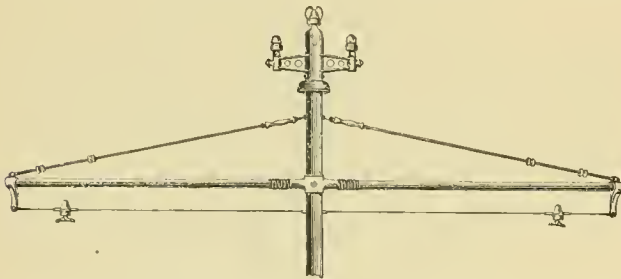

brackets for wood poles with a special ornamental curve brace on each side of the pole under the arm. Several hundred have also been ordered for the Rutland, Vt., Street Railway, and many other roads have been supplied with special brackets.

### HOW THEY BROKE HIM IN.

A Southern exchange, The Birmingham, Ala., Age-Herald, thus pictures a new motorman, who took out his first car the other day.

"It required the united efforts of a motorman, the superintendent and a track boss to manage him. It was like breaking a young mule. He was a tall, grawky

youth from the country. He wore his Sunday clothes that had evidently done service at many camp meetings, and had been his companion at many an afternoon sparking. His hat was of the crop of '85 and should have been laid by in the fall of '90. He had outgrown his Prince Albert coat and it struck him about where the modern sack reaches. His pants were cut in the fresh of '84. Coming down Pearson hill the stiff morning breeze caused the tails of his coat to flap like the sails of a wind mill. He looked not unlike Ichabod Crane mounted on Gunpowder and flying from the headless horseman. At a crossing half way down the hill he had to shut off the current, apply the brakes, and ring the gong at the same time. These simultaneous actions were too much for him and he collapsed. He said it was harder to run an electric car than to drive a spike team. Yet in spite of these difficulties he will write back to the girl he left behind him, a glowing description of the rapid progress he is making in Birmingham, and will close his letter with the following poem:

Far, far from home,  
In great Birmingham I roam.  
All sights are strange to me,  
And home again I long to be.  
Yet there is one familiar sound—  
I hear it in my daily round.  
The 'lectric car's the cotton gin,  
And it buzzes and hums with ceaseless din,  
And when the trolley's turned and lights grow dim,  
It's like the screw packin' cotton in.

### THE HUBLEY TROLLEY HARP.

The accompanying engraving is of a harp made by the Hubley Manufacturing Company, of Lancaster, Pa. The harp shows that it has been designed after the most careful study of the conditions which this important part of the car equipment has to meet. It is made of the best malleable iron and also of the highest grade bronze.

The crescent section of the side bars adds strength and lightness, and affords a rounded surface that will not



catch on the trolley wire. The pin is fastened by an improved method, giving a large bearing and avoiding sharp corners. The metal in the wheel is distributed so that the wheel may be entirely worn out. It is of the highest grade of bearing bronze. Some wheels are in service after a run of 10,000 miles. The wheel is a specialty of the Hubley Company, which furnishes complete equipments for electric railway plants, and the works are being doubled to accommodate the increase in demand.

A GANG of thieves was one day recently discovered loading up and hauling off everything movable, on the Forest Park & Clayton Electric line, of St. Louis.

### THE AMERICAN ELECTRICAL WORKS.

On the 25th of August, 1894, occurred the sixteenth annual clambake of the American Electrical Works, of Providence, R. I. This is the Fourth of July and Christ-mas and birthday celebration of the electrical fraternity, and the brethren came from Maine to California and York state to New Orleans, to participate. The sixteenth was a particularly happy one, and the Union Club country house was filled with an enthusiastic crowd of friends of the hosts. Artistic menus were carried away by the participants. The motto was

"For this to night thou shalt have shocks"

President Eugene F. Phillips requested Charles W. Price, of New York, to act as toast master. The latter introduced the "flow of soul," including a characteristic and happy speech from President Phillips. It was a jolly occasion, and every participant may put a white stone for August 25, 1894.

The history of the American Electrical Works runs in this wise. The business was begun in 1870 by Mr. Phillips, and the company incorporated in 1882, when the works were removed to Phillipsdale in 1893. Previous to this, the original plant covered 60,000 square feet of floor space in a five-story building in Stewart street, Providence, and a branch factory in Westfield street with 19,000 square feet of floor room. Increase of business, however, compelled the change to Phillipsdale, a suburb of Providence. Here the company has 28½

acres of ground with the fullest of transportation facilities both by land and water. The buildings occupy three acres, and another is in contemplation. The new factory has fully demonstrated the advisability of the change, and the increased output and greater readiness with which goods are delivered delights



W. A. HATHAWAY.

both the company and its patrons. It is one of the largest concerns in the world, and makes a full line of bare and covered wire for all electrical work, including railway feeders, trolley wire, electric light wire, incandescent and flexible cords, americanite, magnet, office and annunciator



E. F. PHILLIPS.

wire, Faraday aerial and underground cable. Included in the facilities of the factory are a rolling mill and a wire mill, giving means of furnishing wires of any size, in unlimited quantities, on short notice. No other company in the United States in electrical lines has more or better friends than has the American Electrical Works. Its branch offices are at 10 Cortlandt street, New York; 241 Madison street, Chicago, and a branch factory in Montreal, known as the Eugene F. Phillips Electrical Works.

The capitalization of the company is \$500,000, with a surplus of \$200,000, and the present officers: Eugene F. Phillips, president; W. A. Hathaway, treasurer, and W. H. Sawyer, secretary. It is needless to state that the moving spirit of the American Electrical Works enterprise is President Phillips, and that Treasurer Hathaway and Secretary Sawyer are able seconds. All have hundreds, nay thousands, of friends in every line of the great electrical industry, and each year adds to the number.

For sixteen years the goodfellowship of the electrical fraternity has centered about the clambake, and as long as Rhode Island clams flourish, may the American Electrical Company and its many friends eat them in high carnival.

### HOW GLASGOW RUNS ITS TRAMWAY.

The first full flush of pride has scarcely faded from the pages of the Glasgow dailies, incident to their hour of triumph when the town went into the street car business, when the very thing we have predicted comes to pass. The road and cars belong to the public, and the public propose to dictate how its own cars shall run. In witness whereof the following letter in the Glasgow Herald is self-explanatory:

SIR:—We have now had a full month's experience of our new tramway management, and I think it must be patent to every unprejudiced mind that if the corporation is to succeed in securing the monopoly of the street traffic a new departure must be made immediately. I think the fact that the corporation have not reduced the fares in any one instance has tended very much to drive the citizens to the rival omnibuses, in which for long distances they can travel one-third cheaper. Now, surely if it pays a private company to run a 26-passenger conveyance with three horses and two attendants, a mile and a half for a penny, it would pay the corporation to run a 40-passenger car with two horses and two attendants double that distance for the same money. Supposing each car should only earn the sum of 3s 6d per journey, this would represent 7s for each horse doing a double journey equal to twelve miles per day, or a total of 104 guineas per year of 52 weeks, six days per week. Now I am informed that the cost of keep for a horse in a large stable averages £30 per year, and at this estimate there would be a margin of £70 odds from each horse, to pay wages and upkeep of plant. Nor do I think this a very rosy estimate when we remember the dividends paid by the old tramway company. The present system of halfpenny fares for half a mile is one that is perplexing and worrying to both passengers and conductors; and I am certain that were a uniform charge of one penny made, and passengers permitted to board and alight from the car where they pleased, it would not only please the citizens, but would speedily drive the opposition from the field. One other suggestion I would offer, and that is, that season tickets be issued for each route, as is done in Aberdeen, so that daily travelers would not require to trouble themselves booking every journey. I believe there is no desire on the part of the tramway committee to make great profits to the town from the working of the cars, and if this be so I know of no better method by which the citizens could have full advantage of their own property than by the early adoption of above proposals.

JAS. GILLIES.

## THE NEW BALL VERTICAL ENGINE.

The Ball Engine Company, of Erie, Pa., has taken advantage of its long experience in building engines for electric service, to design a vertical engine, and in so doing its engineers have tried to put themselves in the place of station owners and operators. It was their object to build an engine rigid and indestructible, but with easily removable, adjustable and interchangeable parts. An independent valve motion is employed for each cylinder, and each of these is a perfect engine in itself. The strength is shown in the symmetrical form of the upright housings. One side of each housing is planed, and they are bolted together in the center of the middle shaft bearing. The bottoms of the housings are bolted to one continuous bed plate. The introduction of the shaft into this engine is accomplished by arranging the shaft boxes in a large jaw, cutting into one side of the housing deep enough to bring the center of the shaft into a plane with the center of the housing, finish spots being provided to meet correspondingly finished surfaces upon the cast iron boxes. Each housing is also pierced by a large rectangular opening on each side, which is shown, covered by a bolted door. These doors have shutter openings in the middle, for the insertion of the hand to feel the connecting rod strap when the engine is in motion, or wrenches to key up the crank boxes. The adjustment of the journal boxes is accomplished by turning the three set screws in each strut. Above the openings for the shaft the housing becomes a round taper column, having on two sides of its inner surface the cross-

head guides, which are cast in place and bored out. Access to the crossheads is secured by elliptical openings on the other side of each housing. The form of housing adopted is strong, convenient of access, and protects the engine from dirt from without, and the power station from oil thrown by the engine. There is a natural ventilation from the shaft boxes up through the column and out of the elliptical openings. The

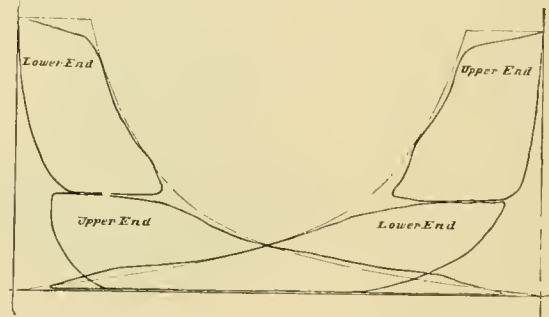

shaft is one piece of forged steel from end to end, and the journals and crank pins are cut from the solid down to the round, and ground to a smooth bearing surface. Covering each pair of crank bells is a counterweight, which puts the engine in exact balance. The cranks are  $180^\circ$  apart. The crossheads are of the double plate pocket type, as used in many Corliss engines, having taper shoes, to compensate for any wear that occurs against the guides. They are of cast iron, with sliding surfaces of babbitt metal. The piston packing is made up of two self adjusting parted rings and a broad junk ring, for centering and guiding the piston in the cylinder. The cylinders are made of charcoal iron, mixed in such proportion of hard and soft as to produce a very strong, close grained iron, which enables the surfaces to take a mirror polish. They are provided with single valves, each of which is practically one piece. The high pressure valve is of the double faced telescopic relief type, with the boiler pressure on the inside. The low pressure is the common letter D form, with improved proportions and construction. The idea of the makers is that if a single valve of good design is used, the indicator cards are so near perfect that it is useless to strive after an ideal perfection, which involves the use of complicated and costly valves, which may, in the end, have a small leakage, which will destroy all the theoretically worked out good effect. They have therefore set themselves to make the simplest and best form of steam valve possible, and provided it with a good governor.

The engine is guaranteed not to vary in speed from full to no load more than 1 per cent. The accompanying indicator diagrams are a practical illustration of what these valves can do, and of the high grade of expansion realized in a non-condensing engine.

KONIGSBURG, Germany, is to have an electric railway system. The Union Electricity Company is negotiating with the tramway company to that end.

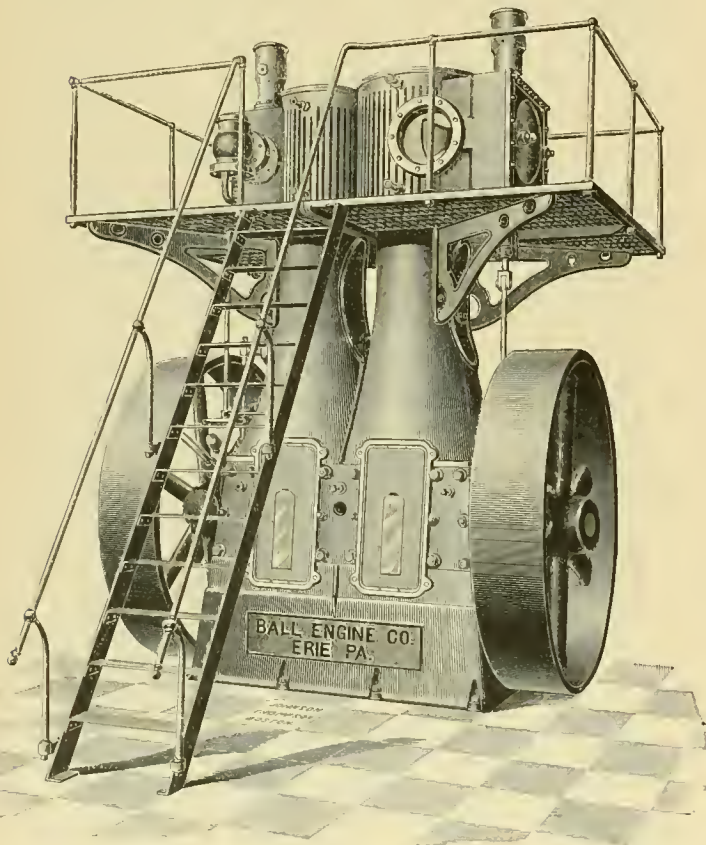

### THE EMPIRE STATE RADIAL TRUCK.

Indications all point to the use of long cars on suburban lines as well as upon lines connecting smaller villages and towns with the larger centers. In fact, as has from time to time been pointed out by the REVIEW, the day of the suburban steam service is ended, and the abdication is in favor of long and commodious electric cars.

With this end in view, the Taylor Electric Truck Company of Troy, N. Y., has placed upon the market a new truck, designed on the principles which have so long obtained in steam railroad construction, to run at a high rate of speed and to carry the car body with ease. The principal advantage attained by the use of long cars is economy of power, and train service, as a trailer is not necessary, and the company making the new truck feels competent to guarantee both service and construction.

The new truck has been called the Empire State Radial and our engraving clearly shows its construction. A continuous steel frame underneath and on both sides of

use of all threaded parts. The brake is so arranged that in use it is applied to the eight wheels at once. The wear of the brake shoes can be taken up by simply pushing forward the dead lever on the inside end of the truck.

The wheels, axles and all wearing parts of the Empire State Radial are made so that they are readily interchangeable with the well known single truck made by the same company, and the master car builders standard jaw and journal box are used. With the form used for attaching motors the weight is put on the driving wheels, and the car mounted on these trucks is designed to mount a 12 per cent grade. The wheel base is short, calculated to enable the truck to curve around a radius of 35 feet. Any motor can be used, and can be examined and repaired without disturbing a single portion of the truck.

The truck in all its details is thoroughly and mechanically constructed, the elliptic springs are made from the best crucible spring steel and fully tested, so that rigorous and exacting service may be relied upon.

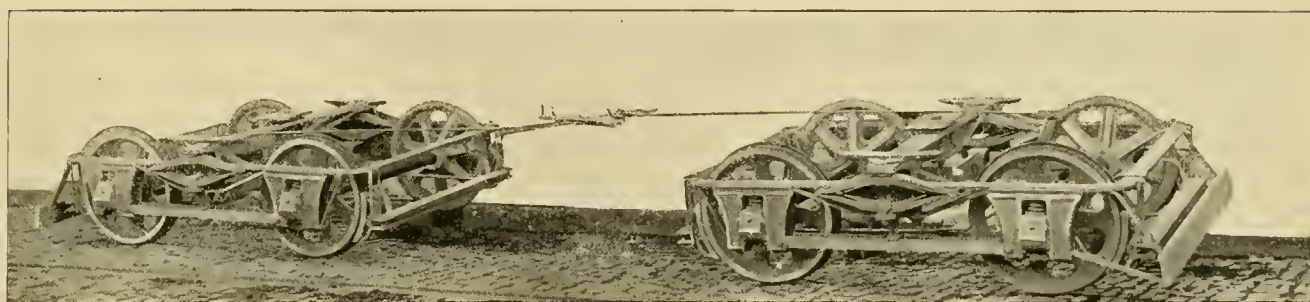

EMPIRE STATE RADIAL TRUCK.

which is a steel arch bar, securely riveted to the frame, forms the base for the construction of the truck. The pedestals or jaws are firmly bolted to the continuous frame, and the axle boxes slide freely between the vertical guides of the pedestal, the axles are thus held parallel to each other, and resist the pressure of the brakes when applied to the wheels. Over the journal boxes are placed coil springs, which receive and reduce the jar caused by obstructions on the tracks, frogs and switches. In the center of the truck on each side of a continuous frame are placed four elliptic springs, securely fastened to the cross tie bar, and upon these springs but not fastened to them, is placed the truck bolster, having curved side bearings. The car is fastened to the truck by a king bolt passing through a male and female center plate, which is secured to the bolster, and the weight and strain of the car is entirely endured by this center plate, while the curved side bearings on the end of the bolster prevent the rocking of the car.

The truck is truly radial, the traction being applied from a point central to the four wheels, and not from plates on the side frame. It is equipped with a solid and substantial lever brake, the connections of which are made by wrought steel clevises and pins, obviating the

### THE LANCASTER RAILWAY CONSTRUCTION COMPANY.

A contract has been awarded to the Lancaster Railway Construction Company, by the Pennsylvania Traction Company, for building forty-three miles of electric railway in Lancaster county, Pa. The lines will run from Lancaster to Manheim, Lancaster to Mechanicsburg, New Holland, Blue Ball and Terre Hill, with an eight-mile branch from Mechanicsburg to Ephrata. The specifications call for Pennsylvania railroad standard construction, including switch and signal system. The overhead construction and all equipment will be of the highest grade, and must be completed, ready for service within ninety days.

The Lancaster Railway Construction Company is a chartered corporation, with ample capital. The officers are: Henry Baumgardner, president; Michael Reilly, vice-president; F. H. Steacy, secretary; J. E. Hubley, treasurer; H. E. Crilly, superintendent of construction.

At Bordeaux, France, a new company proposes to convert the suburban tramway lines into electric lines, similarly to the Bordeaux-Vigeau route.

### DRAWN STEEL TROLLEY POLES.

The United States Projectile Company, of Brooklyn, N. Y., which makes the patent hot pressed motor pinion, which has met with such a marked success, has perfected a new design in trolley poles.

The process is unique and original. The poles are made in the same way as bicycle tubing, and of the same material.

The pole is started from a solid block of steel,  $3\frac{3}{4}$  inches in diameter and 7 inches long, and is gradually drawn out until it is the standard length, i. e. 12 to 13 feet. It is then tapered, making a very neat looking pole, smooth and clean. The steel used, is a fine grade of Swedish, very tough and strong, the poles are claimed to be 25 per cent lighter than those now in use, and are much stronger. The Brooklyn Heights Railroad Company, which is one of the hardest roads on trolley poles in this country, on account of the elevated structures, reports, that with the common poles it often has from six to ten a day broken. With these poles, during all the time they have been used, which is now about six months, and they have upwards of 200 in service, only one pole has been broken, so that it could not be used again. The pole when bent is easily straightened and gives promise of great usefulness.

### THE GOODHAND CONDUIT.

James E. Goodhand, of Baltimore, has patented a conduit not unlike some of its predecessors. The trolley rail is normally dead, and is in sections. As the car

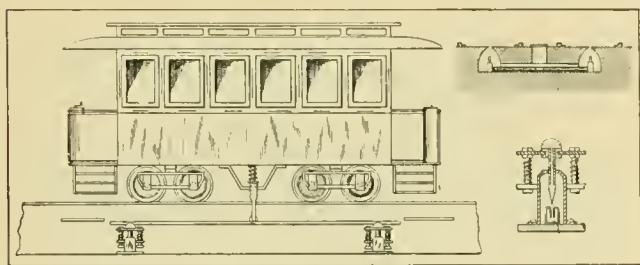

comes along the downward pressing trolley bears down the trolley rail section it is on, until connection is made with the main feeder in the bottom of the conduit. The contact mechanism is shown in detail in the engraving.

### A BIG JOLT AT ALBANY, N. Y.

A most unusual accident occurred on one of the grades of the Albany Railway on August 19. The car to which the accident happened was equipped with iron dogs for keeping the car from running backward when on the way up hill. The car was descending a grade when the device which should have held the dog up allowed it to fall while the car was under way. The result can easily be imagined. The lower end of the car reared up, and the motorman was thrown over the dashboard and seri-

ously injured. The passengers were, of course, considerably shaken up. The dog is a very useful appliance on the up grade, but it has great possibilities for working mischief when it gets loose on the return trip.

### THE NEW STANDARD BEVELED RAILS OF THE CHICAGO CITY RAILWAY.

The Chicago City Railway has adopted the accompanying forms of rail for all its future work both for new and relaid lines. Figure 1 is the 83-pound girder now being rolled by the Johnson Company for the new electric lines and Figure 2 is the rail to be used in relaying worn out cable track. The distinctive feature of these rails, and one that will not be at first noticed, is that the head of the rail is slightly beveled so as to correspond to the shape of the wheel tread. This rail is the design

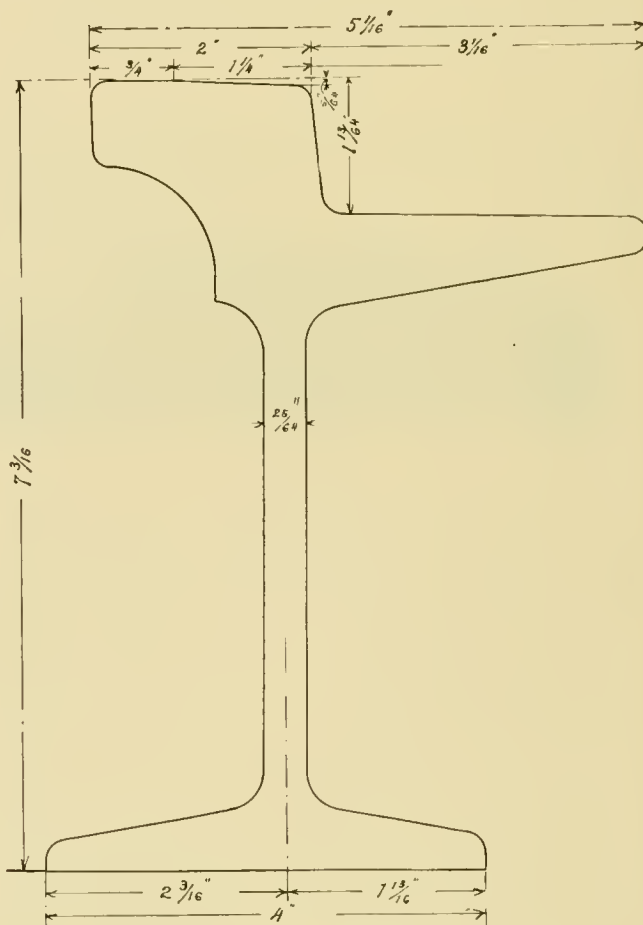

FIG. 1.—SECTION FOR ELECTRIC LINES.

of F. H. Fitch, the civil engineer of the company, and is the result of a very careful study of the wear on rails and wheels. Mr. Fitch's idea is that as long as there is a constant tendency for the wheels to wear the rail head to a bevel and for the wheels to become hollowed out to conform to the shape of the rail head, it is just as well to make them the same shape in the first place. By making them the same shape the wheel bears on a greater surface of the rail, and wheels and rails ought to be longer



lived. At present a great portion of the chilled part of a wheel has to be turned down and is of no account, because the wear on the wheel takes place so much on one groove. The beveled rail is easier to keep clean, and

repair, at all events, and its failure to do so was a violation of its charter and could not be excused on the ground that it held in good faith a different view as to its duties.

A YOUNG FLOOD IN CHICAGO.

September 3 was a damp day in Chicago. The clouds simply went to pieces and it rained an inch an hour from 9 to 12 p. m. The floods invaded both the tunnels under the south branch and the La Salle street bore. The Van Buren street tunnel was fairly swamped by the surface water until fire engines could pump it dry. The cars were unable to use the tunnel for several hours, as the water was five feet deep for a distance of 250 feet. It was an unusual sight. The roar of the big engines reverberating through the tunnel was deafening. In big black clouds the smoke rolled away and passed out at the east end of the tunnel. In the dimmed light of the arc lamps the muddy level of water stretched away like a river, while the cable trains rising above it seemed like wrecks cast away after a storm.

ANOTHER CAR FACTORY.

On August 25, at 2:15 p. m., a new industry was started at Cortland, N. Y., when the contract was signed by President E. E. Ellis, of the Cortland Omnibus & Cab Company, binding the latter to build four new electric street cars for the Cortland & Homer Street Railway. There is no reason why the Omnibus & Cab Company cannot turn out good street cars, since for many years it has placed on the market the highest class of omnibusses, cabs and carriages.

The most of street car builders have started with carriage shops and the present one will be no exception. The four cars to be built will be 18 feet long and finished elegantly, as the workmanship of the company demands.

M. M. Jacobs, of the New York Electrical Engineering Company, builder of the Cortland & Homer Street Railway, was the party of the first part in the contract.

GAS MOTORS IN EUROPE.

Frank H. Mason, consul general at Frankfort, Germany, has submitted to the department of state at Washington an additional report on gas motors in that city. By the death of the inventor, Luhrig, the progress of gas motors in Germany has been checked, but electricity goes steadily forward.

A gas motor is working now on the Croydon, England, tramways. It is described by Engineering.

"The car is not noticeably different from a horse car. It runs quietly and easily, emitting neither smoke nor steam, and is quite under control. Inside passengers can hear a slight rumble of machinery and perceive a trifling vibration; but, after a minute or two, these are unheeded, and practically, there is nothing to detract from their comfort. Neither they nor the bystanders in the street can perceive any machinery whatever, for the engine and

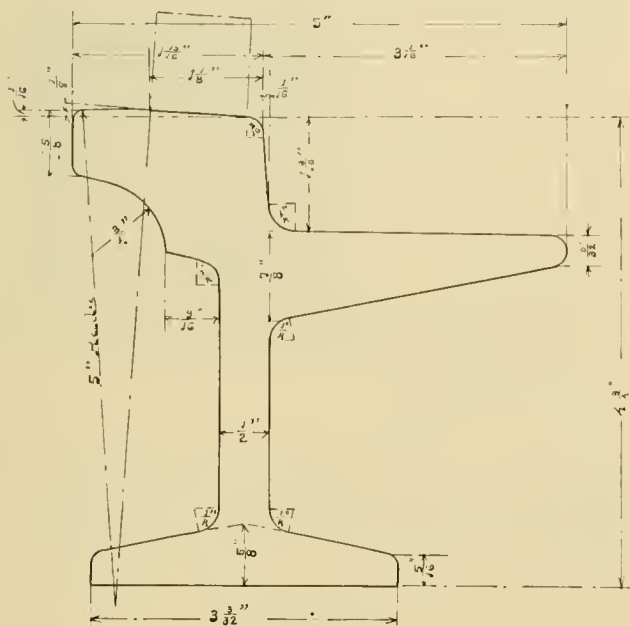

FIG. 2.—SECTION FOR CABLE LINES.

while the results as to wheel wear may not be up to expectations, it is hard to see where any harm can come, while on the other hand there are good reasons for thinking that it will be a substantial improvement.

THE VICKSBURG CASE.

Judge Crisman, in the State vs. the Vicksburg, Miss., Street Railway Company, annulled its charter on the following grounds:

1. That the company failed to maintain its track in repair and that it became a public nuisance, obstructing travel and rendering the use of the streets by the public difficult and unsafe.

2. That the company was insolvent and unable to build and operate a railroad in a suitable and proper way.

3. That the company had neglected for a year or more to operate the road at all.

The company claimed that the city refused to put any gravel upon the streets, and that in consequence it was impracticable to keep up the tracks without unreasonable expenditure. That they were willing to do their part if the city would do its part. That it made many propositions to the city, for settlement by arbitration and otherwise, which were refused, and that it was the fault of the city and not the company that the streets were out of repair. That they were not insolvent, but could build a good electric railway within a reasonable time if the pending suits were out of the way.

The court held it was the duty of the company to keep its tracks, and the street for three feet on each side, in

gearing are entirely inclosed, the motor lying under one seat and the wheels and clutches under the floor of the car. \* \* \* It carries twenty-eight passengers in all and makes a very fair speed, the limit allowed by the board of trade being 8 miles per hour. With the slow gear in action, it will readily mount an incline of 1-in-23, with a short piece of 1-in-16, and in coming down, it can be stopped by the brakes in its own length. It also goes round a curve of 35 feet radius on a 1-in-27 grade. Its weight, when filled with passengers, is 5½ tons. For gas, it costs 1d. (2 cents) per mile, against 3½d. (7 cents) per mile for fodder and bedding for horses; so that the gas-motor car starts with an advantage of 2½d. (5 cents) per mile. The performance of the car is quite satisfactory”

As the horse car is the only method of traction compared, the dictum given by the consul that gas motors are improving and likely to supplant horses is hardly credible.

THE DANIELS' STEEL TIE.

The great objection that has so far practically kept the metallic tie from common use in America, has been the first cost of such a tie. Of course there are other minor difficulties which were experienced on steam roads and which would not occur in covered street railway

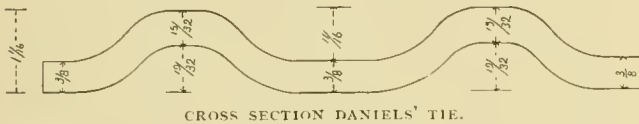

work, where the track has no such tendency to get out of line as on steam roads. The first cost, however, has been the chief obstacle. In America it is not always a question of what lasts the longest, but of what the company is able to buy.

The Daniels' steel tie, owing to the peculiar method in which it is obtained, is nearly as cheap as wood, and when it comes to a question of durability, there is no question as to which is superior. This tie is rolled from old

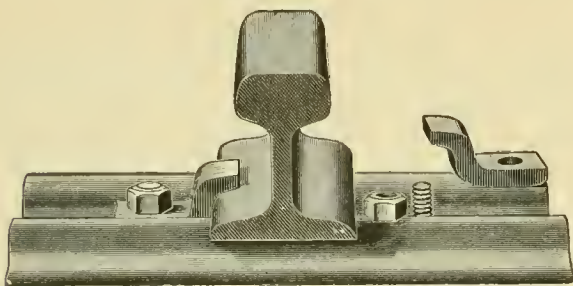

rails, and hence its cheapness. The process of rolling was perfected by R. E. Daniels, who controls the Daniels' Steel Railroad Tie Company, and has had a life-long experience in the rolling mill business. The old rails are cut up into the proper lengths with shears and put into the usual rolling mill furnace. At the right heat they are started through the rolls. The metal is gradu-

ally worked into a section having four corrugations in it, and from this section two ties are made. The rail head forms the basis for one tie and the base for the other, the ties being separated as they pass through the rolls. When the ties come from the rolls, they are automatically carried while still hot into a vat of tar. This gives them a good non-corrosive coat, which permeates the surface of the metal. The Youngstown mills of the Daniels' Steel

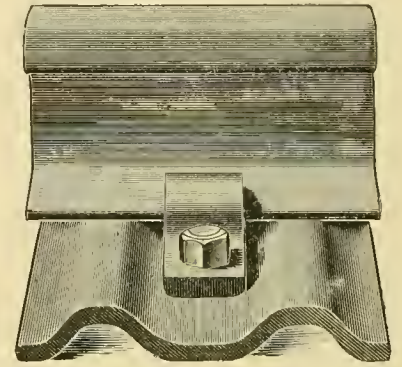

Railroad Tie Company have a capacity at present of 2,300 ties a day, and the manufacture of these ties for the west will probably begin soon in Chicago. The rail fastenings are simply clips held down by common fish-plate bolts. These ties are being put under some spe-

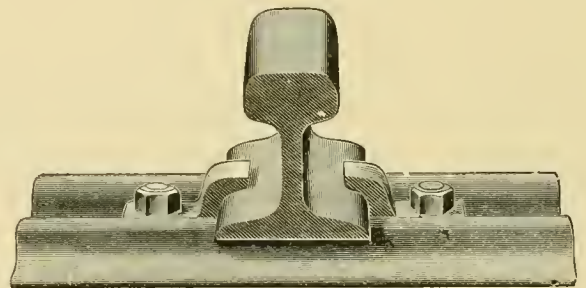

cial work which is being made by the Paige Iron Works of this city for the Terre Haute Street Railway, and some will be shown with the Paige exhibit at the Atlanta convention. The makers of special work like the tie very much, because with it the work must be laid as it was in the shops, and cannot fail to give satisfaction. Some will also be used on straight line construction at Terre Haute.

California in Three and One-Half Days.

If you are going to California and desire to make the journey in the most economical, quick and comfortable manner, purchase your ticket via the Chicago & Northwestern, Union Pacific and Southern Pacific Railways. Pullman drawing-room sleeping cars are run from Chicago to San Francisco without change, in three and one-half days. Completely furnished tourist sleeping cars are also run in which accommodations can be procured by passengers holding either first or second-class tickets at a cost of only \$4 per berth from Chicago to San Francisco and other California points. The hour of departure of trains from Chicago affords prompt connections with all trains from the east and south. Variable route excursion tickets, allowing nine months' stay in the health-giving climate of California, second-class tickets of low rates, sleeping car reservations and full information can be procured of any ticket agent, or by addressing W. A. Thrall, General Passenger and Ticket Agent, Chicago & Northwestern Railway, Chicago

### A GERMAN RAIL CLEANER.

A special tramway rail cleaner in the form of a cart is the invention of C. T. Bischoff, of Hamburg, Germany. It is intended to run on a special truck, and consists of scrapers borne down by weighted levers. Behind the scrapers brushes follow, revolving in the same direction

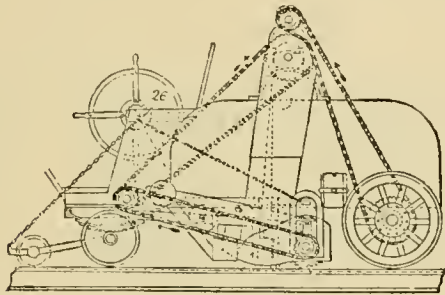

as the hands of a watch. The brushes drive the dust and dirt into a box, which is emptied by a chain of buckets into a larger receptacle by means of a gear chain. The brushes and levers may be raised so that the machine may be driven along the road. The whole is driven from the cart wheels.

### THE TROLLEY PARTY FAD IN PHILADELPHIA.

With the advent of the trolley in Philadelphia came also the accompanying increase in business and pleasure.

The most extensive craze induced since the anti-trolley yawp of the daily press, has been the trolley party, in regard to which the Public Ledger, under date of August 24, has considerable to say:

"Trolley parties seem to be the most popular amusement yet discovered for those who are not enjoying the seashore or mountains," says the Ledger. "The excitement at the spacious car house of the People's Traction Company, at Eighth and Dauphin streets, last night was intense. General Manager L. H. McIntire, when seen, was surrounded by a group of eager young ladies, and, with his usual coolness, he was endeavoring to bring order out of chaos. In the intervals of quiet he expressed himself highly delighted with the success of the trolleys on this branch. As he expressed it, 'last night was the night of all nights.'

"Forty chartered cars ran over the line, carrying trolley parties, and orders were still pouring in. All the available cars and men were on duty, making double trips, necessitating the use of closed cars on the regular trips.

"Of the forty cars chartered yesterday, seventeen were engaged by Germantown parties, and twenty-three by parties from the city. The people in the neighborhood of Snyder avenue are waking up to the fact that for a small outlay they can make a trip to the beautiful suburb of Germantown, and many are availing themselves of

the opportunity. Recently one party secured a car for three successive nights, and last night a car was chartered for two round trips. A car can be engaged for a whole or half trip. Contrary to reports, the price has not been advanced, but remains the same.

"Several of the parties last night were accompanied by brass bands, and the majority of them were made up of ladies."

Many social clubs, instead of giving balls or banquets, have begun to take their evenings' pleasures on the cars in the open air.

The practice has many advantages over ordinary picnics and gayeties, among them: cheapness, healthfulness and harmlessness. No next day lassitude or headaches follow a night on the car, and the pure air and pleasureable excitement are as good for the nerves and digestion as much doctors' physic and verily less expensive.

### ELECTRIC HEADLIGHTS.

It seems strange that electric headlights are so scarce on electric roads. While other roads not operating by electricity would give a good deal if they could get rid of the oil lamp, electric roads have persisted in perpetrating the oil-headlight nuisance on themselves. The only reason for using oil headlights is that they can be used to repair the machinery when the car breaks down on the road. If such a reason were given to a man unacquainted with electric railway practice, he would certainly take it as a joke and could not be made to believe that it is the solemn reason which governs several hun-

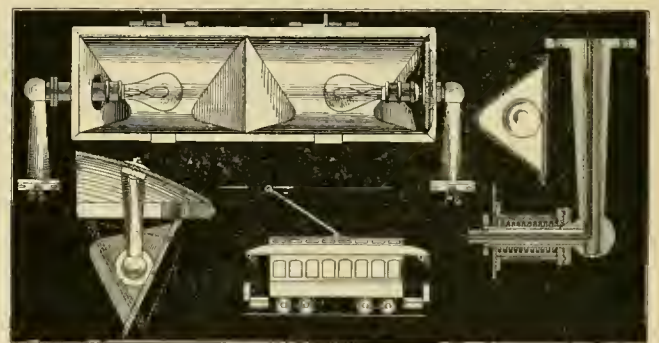

dred street railway men in their choice of headlights. A lantern and some candles can be made a part of the outfit of every car and kept in or near the tool box. They should be made subject to the same rules as the car tools, as regards maintenance and loss. Being used but once in a great while, they cost almost nothing to maintain. Compare this with the oil headlight, which requires a formidable department of its own, with a large storage room and a corps of cleaners and trimmers, and there is no question as to the superiority of the electric light for regular use. The work of getting out the oil headlights and putting them on all the cars every evening is no small task in itself. Superintendent G. W. Baumhoff, of the

Lindell Railway, St. Louis, has designed one of the neatest things in the way of an electric headlight that has been brought out yet. It contains two lamps placed under the edge of the hood. The important feature is that the reflector can be turned so as to light the platform. Both reflectors are turned so as to throw the light forward. The headlight lights the track for about 150 feet, and the one on the rear platform throws light on the platform and into the car. Mr. Baumhoff says that two men were required on his system to take care of the oil lamps, and since using the electric lights he figures that the salary of two men is saved, the current and incandescent lamps used being equivalent to the oil and breakage of lamp chimneys.

### THE ALDERMAN'S DREAM.

The alderman dreamed that he was dead and with great fear and trembling he stood before the pearly gates, and knocked ever so timidly.

"Come into the ante-room," said a voice.

The alderman obeyed with the same alacrity he had always shown when on earth he was called into the ante-room to participate in a star chamber session. Then he saw an immense pair of scales and the clerk of the court dressed in white, with a pen interrogation-pointed behind his ear. He trembled, for he realized that his time had come for weighing in, and, as he carried no weights in his pockets, he might be found wanting.

"Where do you come from?" thundered the voice, now no longer mild.

"From London, Ontario," replied the quaking alderman, as he thanked his lucky star that it was not Hamilton, for in that case he would not have stood any show at all.

"What was your course on the electric railway question?"

The alderman's conscience smote him, yet he managed to reply, "I wanted cheap fares."

"Is that all?"

Was that all! The alderman was going to laugh outright, but he remembered where he was. "No," he replied, "I wanted a percentage."

The clerk's pen was working like lightning. "What else?"

"Mileage," answered the alderman, unabashed and beginning to feel at home.

The man with the pen was looking black and putting down marks equally sombre. "What else did you want, pray?" He was sarcastic now.

"The company to supply the paving material."

"Go on."

"And to supply all labor."

"Yes."

"And pave or repave whenever the city said so."

"Anything else?"

"Well, yes. I wanted the line to run past some promising real estate that I owned. Of course it meant crossing several railroad tracks, but then you know it would have increased the value of my property."

"Nothing else, I suppose!" asked the white-robed scribe as he prepared to cast up accounts.

"Hold on," cried the alderman, as his bosom swelled with conscious pride, "we wanted the company to employ only home labor, and work their men only ten hours a day."

"Did you do that because of your love for the working men, or for votes?"

The alderman was candid. He knew it was no time for levity. "Votes," he replied, as he hung his head.

"Look here, alderman," spoke up the book-keeper, you want neither heaven nor an electric road. What you want is the earth. First elevator to the left going down. Next!"

And the alderman woke to find the council in full session.—London (Can.) Advertiser.

### FIFTY-AMPERE CAR FUSES.

Copper fuses of about 50 amperes capacity have been in use on the cars of the Twenty-second street electric road of this city for several weeks. The company found itself obliged to take care of as many cars as possible with a small temporary power plant which could not be enlarged. To do this, W. F. Brennan, the superintendent, began to educate the motormen so as to save current. At last he hit upon an educator which is more powerful than any number of words. The educator is a number 25 copper wire used as a car fuse. The fuse (unlike an inspector) is always on hand, and the moment a motorman gets careless about crowding on the current he is called to account by the blowing of the fuse. As the motormen are no less lazy than the rest of the human family, they do not relish putting in fuses. As the finding of a double fuse on a man's car means his discharge, there is no alternative but to be careful. A great variety of fuses were experimented with and the number 25 copper wire hit upon as being the most satisfactory for the purpose. This fuse will blow with a current of 50 amperes if it flows for more than two or three seconds. As long as motormen handle their cares carefully they have no trouble, but the moment they get careless and disobey orders, out goes the fuse. Such light fuses are made possible only by the fact that the line is perfectly level. It is probably the lightest fuse used in this service in the world. When hauling trailers, two fuses of this size are put in, although trailers were hauled for two days with the 50-ampere fuse. In blowing, this fuse makes very little disturbance. Even if such fuses are not used regularly, they are a help in training men on level lines, and it is safe to say that the motormen on Twenty-second street will be the better for having served a term under the 50-ampere fuse.

ZACARIAH BOSLEY, night engineer at the Terre Haute, Ind., Street Railway Company's power house, was killed by the current at the power house, August 11. He was troubled with heart disease.

## THE TECHNIC IMPROVED RAIL BOND.

The Technic Electrical Works, of Philadelphia, have placed upon the market an improved rail bond, an illustration of which is self explanatory. It consists essentially of a soft copper rod of the same diameter as the hole in the rail, but bent and slotted at the end. Having been inserted into the rail, a hardened steel wedge is driven into the copper at the bend. The wedge is somewhat larger than the slot, and is driven in to such a depth that

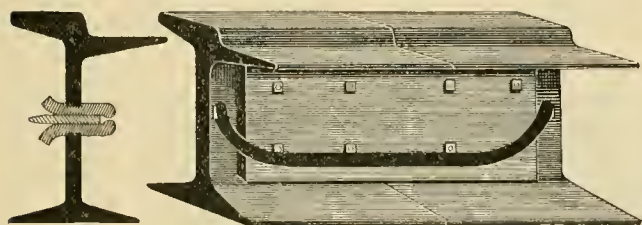

the soft copper may be closed over it to prevent its slipping out. This spreads the bond over the edge of the hole in the rail, and forces apart the split ends at the same time, practically riveting the bond and making a permanent and positive contact that is not affected by any vibration of the rail. The bond can be placed very rapidly, using only a hammer and cold chisel to open the slot at the bend, and at the same time the contact is claimed to be as effective and more reliable in its results than bonding with channel pins, yet carrying the same amount of current. Our engraving displays a section of the rail at the bond, as well as a lateral view of this excellent device.

## RATTLE IN STREET CARS.

"Why on earth," asked a street car patron the other day, "can't box cars be made so that passengers will not be continually thinking that they are being treated to a performance on the tin pan dinner gong of some country railroad eating room? Every closed street car I get into could give pandemonium pointers on noise."

In spite of the exaggeration, the man expressed a great truth. Although the disappearance of double reduction motors has reduced the noise to a minimum to those along the street, there is still a great surplus of noise inside the car. This materially takes away from the pleasure of riding in closed cars, for many passengers, at least. The greatest source of noise seems to be the glass, which is not tightly enough secured in the window sashes. Some think that the principal noise is from the rattle of the sashes, but a little investigation will show that the trouble is between the glass and sash, and not between the sash and window casing. It is, of course, not to be expected that a light street car, running on a dirty track, can be made as quiet as heavy steam cars, running on perfectly clean rails. There is, however, undoubtedly room for improvement in this particular. Every little item of this kind counts in the long run, and every inducement should be held out to create travel during the time of closed cars, when the traffic is lightest.

## A PREACHER WITH SENSE.

Dr. Robert S. MacArthur, pastor of the Calvary Baptist Church, New York, and one of the foremost clergymen of his denomination in the world, was at the late Baptist Young Peoples' Convention in Toronto, where he was of course interviewed on the subject of Sunday cars. In the course of this interview Dr. MacArthur said: "Well, I make it a rule never to cross a bridge before I come to it. In American cities we are not much in danger of a too puritanical interpretation of the law. I do not know enough of your local conditions to express an opinion either for or against them. I am disposed to make my creed more strict for myself than for my neighbor. Were I in Toronto it is possible that I might side with the brethren against them, but I know that in New York if we did not have a Sunday car service it would mean the entire recasting of the personnel of the membership of the city's churches. I once knew an old clergyman so prejudiced against Sunday cars that when ever he went abroad of a Sunday he had to hire a carriage and pair, thus making Sunday labor for one whole man and two whole horses, when otherwise he might have utilized one-twenty-fifth of a man or one-twenty-fifth of a team of horses. Its hard to be consistent, isn't it? I believe in minimizing one's Sunday travel so far as possible, but when it is a matter of necessity to keep an appointment on a Sunday, I do not hesitate to use both the street cars and the elevated railroad to reach my destination."

## TORONTOS' BLUE LAW.

The pious people of Toronto, as is well known to REVIEW readers, do not allow the street railway companies to run cars on Sunday. An enterprising citizen, however, has started a bus system, and allows the people to contribute what they will. On July 15, heroic measures were taken to keep the wicked horse cars from desecrating the sabbath, and a large force of extra men was kept ready to pounce on them should they emerge. The bus man was also stopped. Police were every where, on corners, and even in the cars. Such a ridiculous sight has not been known since the enforcement of the blue laws of Connecticut, and as the Toronto World observes: "Toronto is about to get into a nice old pickle, lots of law, lots of action for damages, also a reputation that will make her the laughing stock of America. Torontos' business reputation will be ruined by the crank Sabbatarians and crank laws."

The Globe says that the mayor was the first man to run counter to the law, as he hired a coupe and drove about inspecting the police.

Perhaps the dear public will get tired of this business some day.

THE Communal administration of Jekaterinsdar, Russia, will receive offers for the establishment of electric or horse tramways in that town until July 25.

### SPECIAL WORK WITH T RAIL AT PAIGE IRON WORKS.

The accompanying engraving is of the initial part of a Y curve, as it lay on the floor of the assembling room of the Paige Iron Works, of this city, before it was shipped to the Terre Haute Electric Railway. It is laid on the Daniels steel tie, and is one of several pieces of special work which the Paige Iron Works have made for that road. The 72-pound shanghai T rail is used on this as on the other Terre Haute work. The engraving shows the Paige method of attaching a guard to the T rail. The policy

### ENGINEERING DIFFICULTIES IN NEW ORLEANS.

The great trial of the constructing engineer in New Orleans is water. In our April issue, some of the peculiar methods of pole setting in the quicksands of that city were illustrated. A good story is told of the attempt of some pits in the Traction Company's new car barn to float away. The pits were made of wood with caulked joints so as to be water tight. One night some of the pits seemed to have a tendency to float and some 300 car wheels were put on them to hold them down. The



PAIGE IRON WORKS—SINGLE TRACK T RAIL Y CURVE BUILT OF ILLINOIS STEEL COMPANY'S SHANGHAI T RAIL. SET ON DANIELS STEEL TIES.

of the company on work of this kind is to make it as much like steam road practice as possible. The curves on this, and all the other work mentioned, are transition, so as to give an easy motion to the cars. The engraving also shows the extensive facilities the Paige Iron Works have for handling work of this kind. They began on steam road work, and the increasingly severe requirements of street railways have brought it about that there is a demand for the kind of work here turned out, viz., heavy steam road practice adapted to paved streets.

The Paige Works have also in hand for the Chicago City Railway one of the largest orders ever placed for special street railway work. The special is for curves and switches on cable tracks and much of it is very complicated.

Don't fail to visit the REVIEW at the Atlanta Convention.

next morning the pits were found to have risen bodily and taken their load of car wheels with them. Hydraulic jacks are all right in their place, but their place is in the pit, and not under it. Those who work in New Orleans need to anchor their structures somewhere in the neighborhood of China if they are expected to stay.

THE New York L roads are waking up to the necessities of inducing traffic. A novel accommodation for wheelmen has been arranged by the Kings County "L" road. For the convenience of cyclers who desire to use the macadamized roads in Queens county, a special car for transporting bicycles will be run from the Franklin and Nostrand avenue stations to the city line on Saturdays, Sundays, and holidays. Wheels will be checked, and a charge of ten cents will be made for each trip in one direction. Time tables have been placed in all the stations of the road.



VOGAN BROTHERS, of New Castle, Pa., report business on the increase, and good reports from their sand boxes, folding gates and draw bars.

THE Peckham Motor Truck & Wheel Company has closed an order for 75 trucks with the Metropolitan Traction Company of New York.

THE Fuel Economizer Company, of Matteawan, N. Y., reports a medal of honor awarded to the Green fuel economizer by the Antwerp Exposition.

THE Edward P. Allis Company, of Milwaukee, has given a mortgage on its plant for \$340,000 to the Northwestern Mutual Life Insurance Company.

THE Mather Electric Company has just recently sold two 130-kilowatt generators to the Danbury & Bethel Electric Railway Company, of Danbury, Conn.

C. S. WILSON, retiring superintendent of the Mobile, Ala., Light & Railway Company, was presented with a handsome gold medal from his employes on the severance of his relation.

FRANK J. LEWIS, late of the Steel Motor Company and the Eastern Electrical Equipment Company, has sold out his latter interest, to establish a supply concern of his own in Cleveland.

H. J. WIGHTMAN & Co., Scranton, Pa., reports an excellent summer trade, and a large order just completed for the Scranton Traction Company, with another for the Lackawanna Valley Rapid Transit Company.

THOMAS PARKER, Ltd., London, is the title of a new company, of which the well-known electrician, Thomas Parker is the head. The capital is named at \$375,000, of which \$15,000 in shares of \$50 each are open for public subscription.

THE Siemens-Halske Electric Company of America reports six contracts for various classes of machinery since the fire. The two most important are a large lighting plant for Hotel Savoy, New York, and a power transmission plant for Franklin MacVeagh & Co., of Chicago.

THE Okonite Company, Ltd., 13 Park Row, New York, is doing a good business in its well known insulated wires and cables, and reports that the sales for August exceed those for any other month during the current year. The company anticipates an excellent fall and winter business.

THE International Register Company, Chicago, has recently equipped the Cedar Rapids & Marion Street Railway, the Toledo & Maumee, O., and the Dennison, Tex., Street Railway, with its well known portable register, while the Akron & Cuyahoga Falls has been equipped with the International stationary.

THE A. Mertes Manufacturing Company, Pittsburg, is putting in a new gear cutting machine and will soon have one of the largest gear cutting plants in the country. The success of the company is large and deserved, and with the new equipment will be able to handle more orders with neatness and dispatch.

THE Simplex Electric Company has been awarded the contracts for braided caoutchouc wire in the New Castle Square Theater, Boston, and the Congressional Library building at Washington, D. C. The latter is a government building, and the selection of Simplex wire for it is a deserved testimonial of its merits.

THE Alameda, Oakland & Piedmont Electric Railway, Alameda, Cal., has ordered a 400-horse-power tandem compound condensing engine from the Ball Engine Company, Erie, Pa. The splendid running of two former engines furnished, the good results obtained, together with the immunity from repairs, has induced this second order.

ALLAN, WHITE & Co., of Rutherglen, Glasgow, Scotland, compose a new cable making firm. Mr. Allen was formerly connected with George Cradock & Co. and Mr. Whyte with William Smith, of New-Castle-on-Tyne. The new company has thus gathered ample experience and promises to the cable railways of the world a first-class rope.

THE numerous friends of Albert A. Carey (member A. S. M. E.), of the Abendroth & Root Manufacturing Company, New York City, will be sorry to learn that he has been seriously ill for the past few weeks with appendicitis, and was recently obliged to undergo an operation. He is at present doing nicely, and it is expected will be out again within a few days.

ANOTHER cable made by Geo. Cradock & Co., of Wakefield, England, has been taken out of the North Side tunnel loop in Chicago, after a record of 122 days—the best record yet—and it will be remembered that the Cradock ropes have all been record breakers on that loop. There was not a broken wire in its length when it was recently taken out.

THE Ellis Manufacturing Company, of 218 South Fourth street, Philadelphia, has just closed contracts with the Delaware County & Philadelphia Electric Railway Company for an outfit of Hansell equalizing motor trucks. The Ellis Company is now well represented, both east and west, by J. T. Dudley, 136 Liberty street, New York City, and L. S. Boomer, "The Rookery," Chicago.

THE R. A. Crawford Manufacturing Company, Pittsburg, has a house full of fender orders, among them calls from Indianapolis and Terre Haute, Indiana, New Orleans, La., Williamsport and Philadelphia, Pa., Rochester, N. Y., and other points. Nearly all cars in Pittsburg and Allegheny are equipped with the Crawford fender, and the brilliant success of the device promises well for future business.

FRANK X. CICOTT, manager of the railway department of Pettingill-Andrews, of Boston, and of the Billings & Spencer Company drop forged commutator bars, was a Chicago visitor during the first September days. Mr. Cicott has had a very successful western trip and finds old friends and new ones among the street railway men. Few supply men have a wider or more desirable list of acquaintances than Mr. Cicott.

CARTER H. FITZ-HUGH, 1636 Monadnock Block, Chicago, has taken the agency for the western territory of the Central Electric Heating Company, of New York. This company controls the patents of the Dewey, Carpenter, Burton, Ahearn and other heaters, besides having many valuable devices of their own. The coming winter promises well for an extensive use of the Central Electric Heating Company's methods.

THE Fuel Economizer Company of Matteawan, N. Y., has recently installed the Green fuel economizers for 3,000-horse-power in the station of the Toronto Street Railway; 1,500-horse-power for the St. Johns, N. B., Railroad; 500-horse-power for the Springfield, Mass., Street Railway Company; 400-horse-power for the Jamestown, N. Y., Street Railway Company. The works have been running full time during the dull season.

WARREN WEBSTER & Co., Camden, N. J., report remarkable activity in their business. The Webster vacuum feed water heater and purifier retains its place in the front rank. Nearly 20,000 horse-power of this specialty has been lately contracted for by prominent steam users. The Cincinnati Street Railway Company called for 1,000 horse-power, the Westinghouse Manufacturing Company for 2,500, the B. & O. tunnel plant for 3,000.

THE McGuire Manufacturing Company, this city, is in receipt of the following unique postal card from Tokio, Japan, from one of the REVIEW readers. It is as follows: "We are now intending to expand our works, so we must purchase more trucks, and yours are most famous recently in Japan. Therefore, we shall be very much obliged if you will forward to our address your general catalogues, which, containing full information in regard to advantages, particulars and prices of your celebrated machinery.—Satouchi & Co."

THE Chicago City Railway Company has let contracts for the following supplies: 120 trucks, to the McGuire Manufacturing Company, Chicago: 240 motors (equip-

ment for 120 cars), to the Westinghouse Electric & Manufacturing Company; 6 generators to the Westinghouse Company; 240 controllers, to the General Electric Company; 6 Wheelock engines, of 500-horse-power each, to the California Engineering Company (this includes rope transmission); 7 Murphy furnaces and 7 J. Mohr boilers of 700-horse-power each. The new equipment will be placed in the Fifty-first street plant.

THE Fulton Truck & Foundry Company, of Cleveland, O., reports a first class business in all lines. The plant is running at its fullest capacity, and President Haycox is greatly delighted thereat. The factory is ready to handle any quantity of street railway supplies, such as motor trucks, trailer trucks, wrecking trucks, wheels and axles, steam car wheels, turn tables, transfer tables, track castings, railroad crossings, special work, draw bars, door fasteners, track cleaners, sand boxes, snow plows, wheel presses, motor lifts, brush holders, and brake shoes.

CHARLES J. MAYER, of Philadelphia, has found his quarters at 600 Betz Building too small and has taken rooms on the twelfth floor of the same building, where he has much more room to handle the goods of the R. D. Nuttall Company, the W. T. C. Macallen Company, the Solar Carbon Company and Streiby & Foot, besides the Nelson insulated overhead crossings made by Arthur Partridge, of St. Louis, of which Mr. Mayer has sold 600 in Philadelphia alone. He has found business much better than he expected since starting last April, and is prepared to quote prices on all line material.

THE Ball Engine Company, Erie, Pa., sends the following list of engines recently sold by that enterprising concern within the last few weeks: Peninsula Electric Light & Power Company, of Houghton, Mich., 350-horse-power tandem compound; Berwick Electric Light Company, Berwick, Pa., 160-horse-power; E. P. Dodge, of Newburyport, Mass., 50-horse-power; City of Adrian, Mich., 70-horse-power, direct coupled to Siemens-Halske dynamo, and nine other engines, ranging in horse-power from 80 to 160, for other than electric purposes. The total horse-power sold in all amounts, to nearly 2,000.

THE Sterling Supply & Manufacturing Company, 97 Bank street, New York, reports the perfecting of a new fender, or life guard, which has been tried on the Broadway, New York City line, for which line a full equipment has been ordered. The capacity of the company's shops has been recently doubled, and to Manager Carson is due the present flourishing condition of this excellent company and its present wide facilities. The general business of the company is in fine condition, and the different departments are full of work. Manager Carson is to be congratulated upon his executive ability and push.

THE Modemann Car Fender, manufactured by the United States Street Car Fender Company, 300 Bennett



Building, New York City, has had a trial in Brooklyn. This device is a wire basket with side wings, weighing about fifty pounds, which sets three inches above the rail. It is said any object, weighing forty pounds or over, coming in contact with it, quickly collapses the fender, which picks up the object and lifts it about 13 inches from the ground. An oscillatory movement prevents injury to the fender by the oscillation of the car. When not in use the fender can be folded on the dash board, thus taking little room when in the barn.

B. J. JONES has resigned his position as superintendent of the Riverside Park Railway and the Sioux City & Leeds Electric Railway, of Sioux City, Iowa. Mr. Jones has had a full experience in street railway construction, having changed the Sioux City Street Railway from horse to electric traction, and the Riverside Park line from locomotive to electricity. He also reconstructed the Sioux City Elevated line when it was changed to electricity, and just recently superintended the rehabilitation of the Sioux City Cable Railway, with its electric equipment. His present address is 221 McKee street, Columbus, O.

THE well known cedar-pole firm, W. C. Sterling & Son, of Monroe, Mich., has just received at their yards at Monroe, a large raft of cedar poles from the north, and expect two more during the summer. One crib in the next raft will be over 400 feet long, the longest that has ever come down the lakes, and contain about 6,000 poles. The Monroe yard is one of the largest in the world, and is well known all over the country. From this yard shipments are made to all points in the United States, and all material in the line of cedar that is used in the construction of electric light, railway, telegraph or telephone lines is manufactured and furnished.

THE Ajax Forge Company, of Chicago, is rapidly making its way to the front rank of special crossing builders for street railway crossings of steam roads. Its latest contract is for the construction of 216 steam railroad crossings for the Chicago City Railway electric lines. The company is naturally elated over securing this order, as the competition was strong and the merits of the case strictly recognized in the matter. The matter of crossings of this character develop a number of questions, both as to mechanical construction and excellence of material, neither of which can afford to be less than the very best.

THE superior workmanship and quality of the metal which the Ohio Brass Company, of Mansfield, Ohio, is employing in the manufacture of railway motor bearings, has resulted in a large increase in its sales of those articles, and they number among their patrons many of the largest roads in the country. These bearings are made of a guaranteed bell metal, and are turned and trued up and milled by special machines lately installed for this purpose. The great care taken with the finish of these insures a perfect fit, and an even and smooth

bearing for the shaft. The Ohio Brass Company has prepared a revised price list of bearings, and at figures which will no doubt largely increase their output.

THE Ohio Brass Company reports orders of considerable size during the month of July, from twenty-five roads, for its Type W material. Among the larger roads are the Middletown & Goshen Traction Company, Middletown, N. Y.; the Consolidated Street Railway Company, Toledo, O.; the Cincinnati Street Railway Company, Cincinnati, O.; Des Moines Street Railroad Company, Des Moines, Ia.; Beaver Valley Traction Company, Beaver Falls, Pa.; Ft. Wayne Electric Railway Company, Ft. Wayne, Ind.; Union Street Railway Company, Saginaw, Mich.; Nashville Traction Company, Nashville, Tenn., and the Columbus Street Railway Company.

B. W. PAYNE & SONS, Elmira, N. Y., the well known engine builders, have closed a contract through their New York office, at 41 Dey street, with Hilton, Hughes & Co., for the installation in the latter's store at Broadway and Ninth street, of four 150-horse-power direct connected engines. The plant will be one of the largest private lighting plants in the world and modern in every particular. The dynamos to be attached to the Payne engines are four 100-kilowatt General Electric multipolar dynamos. Payne & Sons will also furnish six 125-horse-power horizontal tubular boilers. The name of Payne & Sons assures the owners of the plant that economy, neatness and strength will all be conserved in this important plant.

THE Eureka Tempered Copper Company, of North East, Pa., reports a large and ever increasing trade in tempered copper commutator castings. This company is the pioneer in this line of work, and in addition to casting pure tempered copper commutator segments, it refills commutators of every description, including street railway motor and generator commutators. In order to supply the wants of its numerous Eastern customers with greater dispatch, the company now carries in New York a large stock of standard segments for street railway motor and general commutators, as well as finished commutators, for the various systems of street railway motors. The eastern office is located at 126 Liberty street, New York, and J. C. Dolph is their sales agent.

REPORTS of the efficiency of the motors made by the Mather Electric Company, tend to rejoice the hearts of the entire Mather contingent. J. Holt Gates, Monadnock building, Chicago, general western agent, sends in statement of a recent test of a 3-horse-power Manchester motor, in which an efficiency of 92 + per cent was obtained. The general design of the well known Manchester type was followed, and mica insulation is used exclusively. The fields are of cast steel, while the base, sub base, etc., are of cast iron, with the result that the motor is very light for the output. The armature shaft is very large in diameter, doing entirely away with that

prevalent trouble—"springing of shaft." This motor has been thoroughly tried, and has given great satisfaction.

THE Hoppes Manufacturing Company, of Springfield, Ohio, is now busily engaged installing four of its live steam feed-water purifiers of 3,000 horse-power total capacity in the new electric station of the Lindell Railway at St. Louis. The Hoppes Company justly feels somewhat elated in securing this contract, as it was secured in the face of very strong competition. Among other recent sales are the following: Live steam feed-water purifiers of 500 horse-power to the Procter & Gamble Company, Ivorydale, Ohio; 1,500 horse-power to the Indianapolis Light & Power Company; 150 horse-power to Wm. Coombs, of Coldwater, Mich.; 400 horse-power to the National Milling Company of Toledo, Ohio; 150 horse-power to the Cincinnati Street Railway Company; 150 horse-power to Chas. H. Suppes, of Johnstown, Pa.

THE Standard Railway Supply Company during the last four weeks has filled large orders for standard stoves for the J. G. Brill Company and the American Car Company. In each instance the standard stoves were specified by the companies in whose cars these stoves will be placed, and go to parties who last year and year before, purchased Standard stoves direct from the Standard Railway Supply Company. Additional orders have already been placed with the company by several large and by a number of smaller electric roads, also previous users of these stoves. The company is prepared to fill orders on receipt, a full stock being furnished for the fall business. Numerous orders for a full supply of overhead material for new roads and extensions have been filled within the last thirty days, and business in this line is brisk. This concern was recently made the Chicago and northwest sales department for R. D. Nuttall Company, well known manufacturers of gears, pinions, trolleys and supplies for all electric systems. The improved Nuttall trolley base and stand has won the recognition and preference of the electric roads in Chicago, through recent thorough tests, in which the reliability and advantages of their improvements have been demonstrated.

THE NEW SCIENCE REVIEW is a quarterly publication just launched by J. M. Stoddard, of Philadelphia. It is intended to cover a popular field between the purely technical publications and the popular magazines.

WHY go to the sea shore for a vacation trip, when within a night's ride of business the vacationist may find flesh, fish, fowl, boating, and all sorts of healthful recreation among the lovely little resorts reached by the Wisconsin Central Railroad? Even within three hours' ride of Chicago the busy man may find health giving breezes, lakes full of fish and woods full of game. Near Chicago are: Gray's Lake station, with nine ponds accessible; Lake Villa, with an attractive resort; Fox Lake, so well known for beauty, and half a hundred other lovely spots; or if wild scenery is wished a few hours longer takes the tourist into the most savage of mountains and forests in upper Wisconsin and eastern Minnesota. The Wisconsin Central Railroad offices, 204 Clark street, Chicago, will send on application a beautifully illustrated book upon the subject.

## THE WESTERN ELECTRIC TROLLEY HANGERS.

The new trolley hangers brought out by the Western Electric Company on its entrance to the railway field are a modification of the "West End" hanger, and retain all the good points of that hanger. The changes have been toward symmetry, simplicity and lightness. The

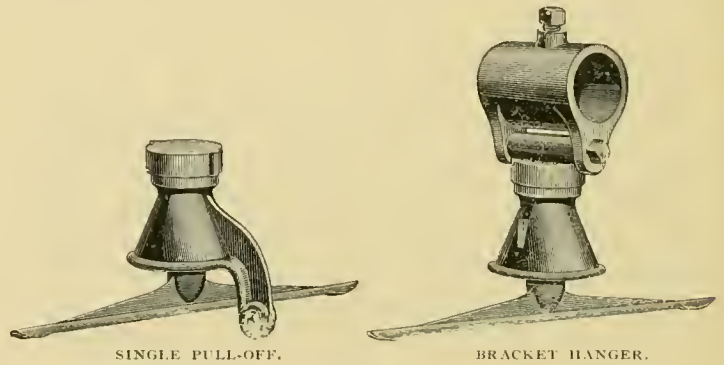

length of the insulation on the bolt of the new hanger is increased over that on the "West End." The first road to use these hangers is the Hestonville, Mantua & Fairmont Passenger Railway, of Philadelphia, where twenty miles are being put up. Several other roads are contemplating its use, and doubtless it will soon become one

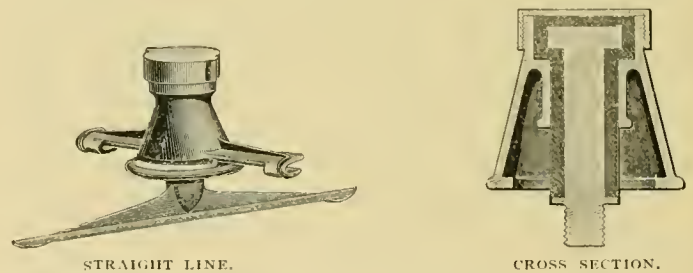

of the standards. In addition to the trolley hangers, there is also a new section insulator and an insulated cross-over. The cross-overs are furnished either rigid or adjustable. It can be put up without cutting a single wire when the line is already up, which is a convenience in construction work. A full line of this company's devices will be shown at the Atlanta convention.

## THE DETROIT SALE.

The purchasers of the Detroit Citizens road entered into a controlling interest by the purchase of 6,025 shares, giving them a majority, the purchase being made by R. T. Wilson & Company, of 33 Wall street. The reorganization gives the following officers and directors: President, Major J. M. Edwards, 33 Wall street, New York; vice-president, M. W. O'Brien, Detroit; treasurer, R. T. Wilson; assistant treasurer, J. V. Johnston, 33 Wall street, New York; secretary, J. R. Stirling; general manager, J. D. Hawks; and general superintendent, J. H. Fry, of Detroit,

## THE RANKEN-FRITSCH CORLISS ENGINE AT ATLANTA.

The visitors to the power house of the Atlanta Consolidated Street Railway Company during the convention, will have the pleasure of seeing the new Corliss engine made by the Ranken & Fritsch Foundry & Machine Company, of St. Louis.

The engine was designed by Manager J. P. Sneddon, of the Ranken-Fritsch Company, and is an 800-horse-power tandem compound condenser. The cylinders are 22 inches high pressure and 40 low pressure, by 48-inch stroke. On the shaft is mounted a 500-kilowatt Westinghouse railway generator, designed for 90 revolutions per minute.

The case is stated mildly when it is said the engine is massive. It is probably the heaviest ever built for the same horse-power. The fly wheel is 18 feet in diameter,

ally heavy proportions. It has bearings on the foundations from cylinder to about seven feet beyond the main shaft. The guide section is cast separate, and bolted to the half bed plate. The cross head is of cast steel, and the cross head shoes, which are babbitted, are 18 by 28 inches. They are adjustable by taper wedges, which have a bearing for the full length of the cross head.

The half bed plate weighs 34,000 pounds, and the guide section tips the balance at 16,000. The on board bearing is a duplicate of the main bearing of the engine, if the latter were separated from the bed plate. It is provided with a vertical adjusting wedge the same as the main bearing. The engine has separate eccentrics for steam and exhaust valves, the former valve being connected with the rocker arm in the usual manner, but the exhaust valve eccentric is connected by an inverted rocker to the wrist plates, which are also inverted, and rock on the hub of the steam wrist plate. Both these valves are double

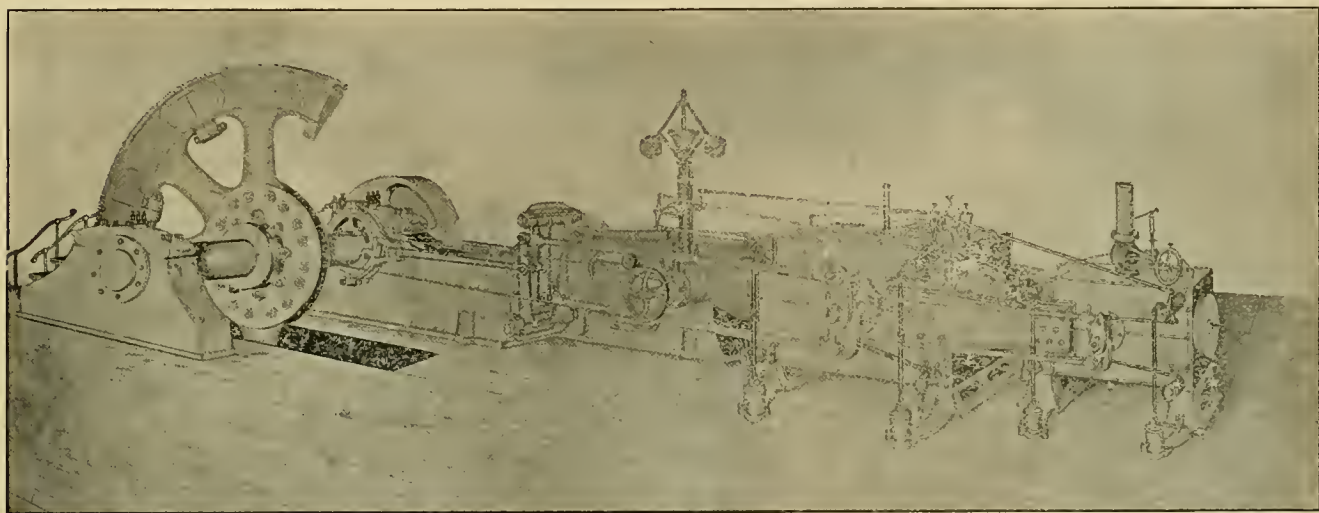

RANKEN & FRITSCH 800-HORSE POWER CORLISS ENGINE BUILT FOR THE ATLANTA CONSOLIDATED.

with a rim section of 19 by 20 inches, built up in eight segments, one hollow oval arm being cast with each segment. The wheel centers are 84 inches in diameter and the ends of the arms secured by 24 three-inch bolts. The rim is held together at the joints by one 2½-inch bolt passing through inwardly, projecting flanges and two wrought iron links 3 by 3 by 24 inches in size. These are shrunk into recesses cast in the face of each segment. This latter is regular rolling mill practice for binding fly wheels and has proved satisfactory in the heaviest work. The main shaft is 21 inches in diameter at the center and 19 inches at the bearings and is forged from hammered selected scrap. It is 20 feet 4 inches long. The main bearings are 19 inches in diameter, 30 inches long, and are adjustable vertically by cast steel taper wedges that are the full length of the bearing, as are also the quarter boxes. By this means the distance between the armature and pole pieces may be regulated. The crank is 72 inches in length and weighs 11,000 pounds. The crank pin is 9 by 10½ inches in size.

The bed plate is of the box girder type and of unusu-

ported and the clearance is very small for both cylinders. The cylinders are connected by cast steel side bearing pieces, which are rigidly secured to both cylinders. The main rod is in rectangular section, both ends being solid. It is of hammered scrap, and weighs 5,000 pounds. The piston rod from the low pressure cylinder is 5⅞ inches in diameter, and keyed in the cross head. On the governor an automatic stop is provided, to guard against the forgetfulness of the engineer. This stop is controlled by an idler pulley, riding on the governor belt. As long as the belt remains intact the stop will remain in place and prevent the engine from shutting down under heavy load. In case of the breaking of the governor belt, however, the idler pulley will swing downward and remove the stop, thus saving the catastrophe often accompanying such an accident.

Both cylinders are provided with water relief valves, but in case of serious trouble from water the steam valves will be raised from their seat. The total weight of the engine is 310,000 pounds and its rated capacity 800 horse-power.

The Ranken-Fritsch engine should be seen by every visitor and will be the center of attraction at the power house. The tendency toward heavy engines is commendable, and we look forward to other good work for street railway plants by the makers of this thoroughly good and reliable engine. We hope to be able to publish extensive tests later, and no doubt they will be consonant with the care, finish and thought put into the machinery. The Ranken-Fritsch Foundry & Machine Company was organized in September, 1888, at St. Louis, Mo. The officers are W. H. Thomson, president; Otto W. Von Schrader, secretary and treasurer; and James P. Sneddon, manager. The company manufactures Corliss and high grade positive moving valve engines, of the highest grade. It is now building two 600-horse-power vertical cross compound direct coupled engines for the city of Chicago. Since the organization in 1888 an addition to the works has been necessitated each year, until now they cover a full city block. The accompanying engraving will give some idea as to their extent. The shops are equipped with traveling cranes, and all the most modern machinery for heavy work. Among the numerous and modern tools are noted a 20-foot boring mill, an 84-inch by 26-foot screw-cutting lathe, a 60-inch by 32-foot lathe, an 8-foot by 8-foot by 30-foot planer, a special Corliss cylinder boring and facing machine, and last, but not least, that important adjunct to a modern engine builder, a 400-ton hydraulic press. The steam railway switches run into the works, so that everything is loaded or unloaded inside of the shops, just where it is needed. We take pleasure in showing a portrait of the general manager, and designer of the engine at Atlanta, J. P. Sneddon, who is a member of the American Society of Mechanical Engineers, born in Scotland, in 1863, but came to the United States at the age of 13; he has been laborer, fireman, steam engineer, apprentice, machinist, chief engineer, master mechanic, etc., successively, now occupying the position of manager with the company.



J. P. SNEDDON.

A MAN burdened with the name of J. Micromegas Carayan is about to launch a flying machine at Oakland, Cal. He has already invented a car starter and a conduit electric railway.

It has not been decided which line of the Metropolitan Traction Company of New York will be equipped with the conduit system recently contracted for with the General Electric Company. It is not probable the matter will be settled soon.

## STREET RAILWAY PATENTS.

ISSUED SEPTEMBER 4, 1894.

Controlling device for electric railway cars. William H. Conrad, Lebanon, Pa., assignor of two thirds to Jacob M. Shenk and William P. Coldren, same place.....	525,336
Controller for electric or other motors. Elmer A. Sperry, Cleveland, O., assignor to the Sperry Electric Railway Company, of Ohio.....	525,394
System and apparatus for the control of electric machines. Elmer A. Sperry, Cleveland, O., assignor to the Sperry Electric Railway Company, of Ohio.....	525,395
Railway switch. Joseph L. La Driere and Spencer I. Stone, Helena, Mont.....	525,423
System of electrical distribution. Thomas C. Coykendall, Rondout, N. Y.....	525,445
System of electrical distribution. Thomas C. Coykendall, Rondout, N. Y.....	525,446
Electric railway system. Francis B. Badt, Chicago, Ill.....	525,480
Electro magnetic car brake. Robert T. Murray and Charles M. Allen, San Francisco, Cal.....	525,505
Car tender. Thomas Ross, Westerly, R. I.....	525,516
Electro-magnetic tractile device. Charles M. Allen, San Francisco, Cal., assignor one half to Robert T. Murray, same place.....	525,523
Car brake. Edward Cliff, Newark, N. J.....	525,533
Conduit electric railway system. Oscar A. Enholm, New York, N. Y., assignor to W. Dean Smith, same place.....	525,539
Headlight reflector. Mark O. Ainslie, Cincinnati, O.....	525,571
Street car truck. Ferdinand E. Canda, New York, N. Y.....	525,599

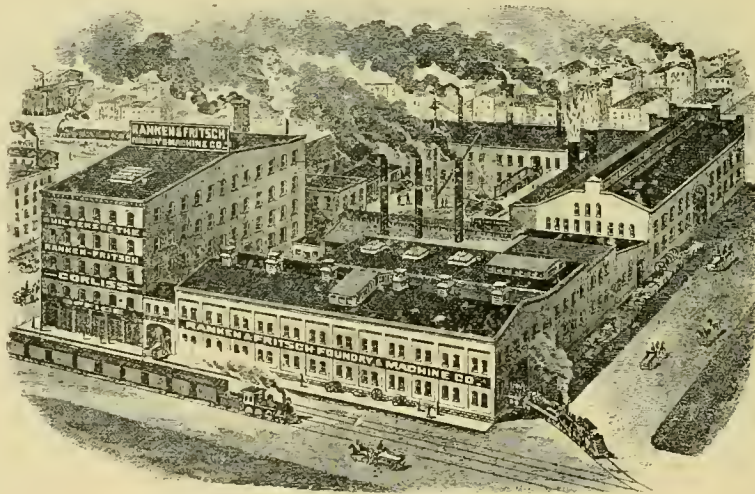

RANKEN & FRITSCH FOUNDRY & MACHINE WORKS, ST. LOUIS.

Car fender. Henry W. Eaton, New York, N. Y.....	525,592
Overhead switch for trolley wires. Hugh M. Greenwood, Brooklyn, N. Y.....	525,598
Street clearing apparatus. Alfred E. Trevithick, St. Henri, Canada.....	525,635
Air brake mechanism. Jacob B. Knudsen, Fernwood, Ill.....	525,686

ISSUED SEPTEMBER 11, 1894.

Electric railway system. Charles S. Bradley, Avon, N. Y.....	525,690
Bus bar insulating support. Albert D. Herrick, Schenectady, N. Y., assignor to the General Electric Company of New York.....	525,708
Combined brake and electric switch for street railway cars. George Brown, Long Island City, N. Y.....	525,782
Trolley pole connection. Maurice R. Mahon and John M. Crane, Newark, N. J.....	525,789
Electric railway. Herbert E. Rider, New York, N. Y., assignor to Adolph Falck, same place.....	525,864
Trolley for electric railroads. Edward Dawson, Terre Haute, Ind.....	525,886

ICE AND SLEET CUTTING TROLLEY WHEELS.

On this page is an illustration of the ice and sleet cutting trolley wheel, manufactured by the Storm Manufacturing Company, Newark, N. J. In our last issue was a note that the Storm Manufacturing Company had obtained the control of both the United States and Canadian patents on this wheel, which was formerly manufactured by Haight & Clark, Albany, N. Y.

Last year this wheel was introduced on a few of the prominent trolley lines of this country, and, we are informed, that without a single exception, every line which tried and used it was enthusiastic in its praises. The company thinks it has a trolley wheel that will automatically remove the incrustations of ice from the wires, so as to leave the latter clean and in perfect condition for the transmission of the current. When a coating of ice forms on a trolley wire it usually gathers on the lower side. The water flows down and is frozen before it falls from the bottom of the wire. The ice remains on the lower side of the wire until melted by the heat of the atmosphere, or removed by mechanical means. The makers say the ice is instantly removed when their trolley wheel comes in contact with it, and there is absolutely no delay in the movement of cars.

The Storm Manufacturing Company has recently issued a circular describing fully the merits of this wheel, and also containing a number of indorsements from well known roads that have used it. This circular will be gladly sent to anyone who may write for it to Newark, N. J. The company will make a display of these wheels at the convention at Atlanta, in October. C. A. Hoagland, of John H. Graham & Co., of New York, will represent the company, and will show and explain the merits of the invention to all who may be interested in it.

A PROMINENT daily in the west, commenting on the rate war in Savannah, where two parallel lines have been hauling passengers at one cent per head, where the former fare was five cents, undertakes to show the cut rate has proved profitable to both contending companies, and drawing an inference from the reduced price of daily papers, tries to establish a prediction that low car fares would prove equally successful. That the decreased price of daily papers from five to two or even one cent has proved a wise business moye to the publishers of daily papers can be readily understood. But the case is in but few respects a parallel one. In these days publishers expect to make little or no profit on subscriptions, depending almost entirely on their revenue from advertising. Hence the struggle to secure circulation, for circulation means advertising and largely regulates the

price therefor. The publisher then gauges the amount and cost of his reading columns in proportion to the advertising. But in the case of the street railway, what is the situation? The manager is expected to constantly improve the service by larger and better cars and more of them. He must give an even longer haul, but seldom with any increase in rates. No, the case in question is no parallel and the day when street cars will haul people at a penny a one is far in the future.



prominent trolley lines of this country, and, we are informed, that without a single exception, every line which tried and used it was enthusiastic in its praises. The company thinks it has a trolley

THE NEW HAVEN REGISTER.

The New Haven Car Register Company is continuing its successful career, and during the past year has introduced its machines on a large number of new roads, until now its list includes 125 lines. Prominent among these are the Philadelphia Traction Company, the North Hudson County Railway Company, Hoboken, N. J., the

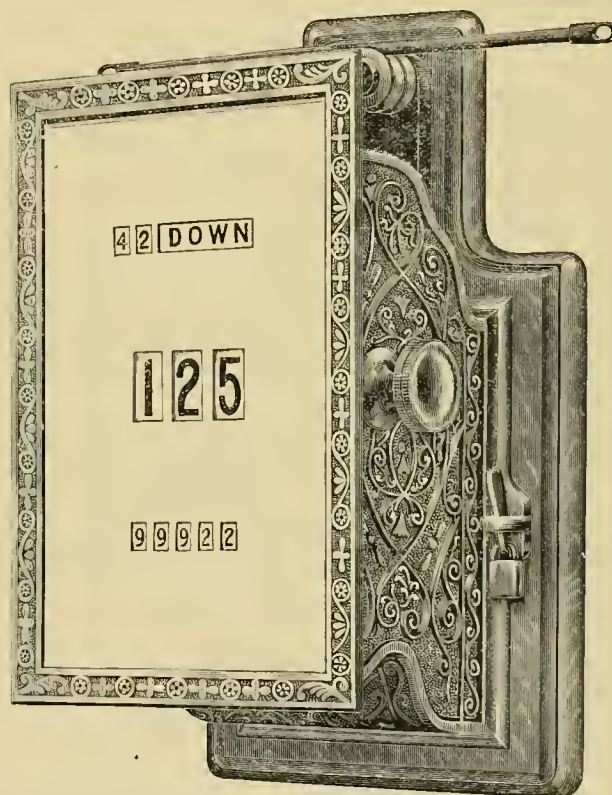

NEW HAVEN REGISTER.

Rochester Railway System, the Montreal & Toronto System and the Oakland Cal., systems.

These registers are made in solid cast bronze cases, at once attractive and durable, and faced with plate glass. Three sets of numerals are exposed; one being the trip record, another the total registrations of all trips for the day or conductor, and the third the total which records to 100,000 and then returns to zero.

The company is energetic in securing business and careful in its inspection of all work leaving the factory, and the result has been an increase in business most gratifying to its friends.

THE Chicago and northwestern members of the American Street Railway Association, and their friends, who will attend the Atlanta convention, have offered to them a choice route by the Monon, via Cincinnati. The city ticket office of the Monon route, 232 Clark street, Chicago, will cheerfully furnish any information in regard to route, trains, tickets, and sleeping car accommodations. The Monon has long been famous for its splendidly equipped car service, and passing as it does through a picturesque country, the trip to Cincinnati is a delightful one.

A NEW section of the Montreal Park & Island Railway has been opened and the road now penetrates five miles into the suburbs. The mayor of Toronto, at the opening ceremonies, paid a graceful compliment to Senator Thiebeaudeau and A. J. Corriveau, whose energy brought about the opening of the road. Joseph E. Roy is chief engineer of the work, and L. E. Marple electrical engineer.

Custer's Last Battlefield.

A visit to this spot, which is now a National Cemetery, is extremely interesting. Here, seventeen years ago, General Custer and five companies of the Seventh U. S. Cavalry, numbering over 200 officers and men, were cut to pieces by the Sioux Indians and allied tribes under Sitting Bull. The battlefield, the valley of the Little Big Horn, located some forty odd miles south of Custer, Montana, a station on the Northern Pacific Railroad, can be easily reached by stage. If you will write Chas. F. Fee, St. Paul, Minnesota, inclosing four cents in postage, he will send you a handsomely illustrated 100 page book, free of charge, in which you will find a graphic account of the sad catastrophe which overtook the brave Custer and his followers in the valley of the Little Big Horn, in June, '76.



**WARDWELL BROTHERS,**  
**Electric • Railway • Builders,**  
 NEW HAVEN, CONN.  
 BOX 868.

Will make proposals for the Construction of all Classes of Street Railway Tracks, Power Houses, Etc.

**NOTICE.**

On the First Tuesday in October, 1894, same being the 2nd day of said month, I will offer for sale all the property of The North Side Railway Company, as follows:

15 Car Bodies (Brownell make); 15 Bemis Trucks, Motors for same, (Thomson-Houston make) type F30, 3, D62 Generator; One Hazelton Trypod Boiler, 500 horse power; One Compound Condenser Hamilton-Corless Engine, 350 horse power; 4 miles of Street Railway Track; 12 miles of Over-Head Wire (Single O, hard-drawn), together with all Station appliances and things necessary to the operation of an Electric Street Car Line, also a lease upon the property and franchises of The Fort Worth Street Car Company, with an option of purchase, at and for the sum of \$100,000.00

**N. HARDING, Receiver.**

Ft. Worth, Tex.

**FOR SALE.**

**One 18 Foot Closed Vestibuled Car Body.**

NEVER BEEN USED.

For Particulars, address,

**Akron Street Railway Co.**

**AKRON, OHIO.**

**C. E. LOSS & CO.,**  
 General Railway Contractors.

Estimates made on all classes of Engineering Work.

**621 Pullman Bldg. CHICAGO.**

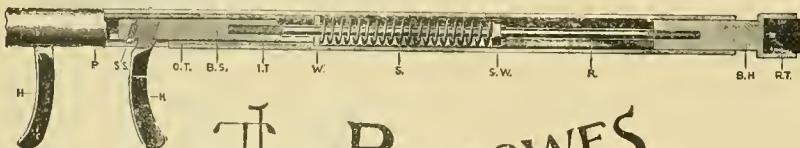

Send for Descriptive Pamphlet.

**The BURROWES**  
 AUTOMATIC **CAR CURTAINS,**



Largest Factories in World.



For Open or Closed Cars.  
 Highest Award at Chicago.

MADE BY  
**The E. T. BURROWES**  
 PORTLAND, MAINE, U.S.A.

Trade Mark **"Oakette"**  
 Our new waterproof, leather coated, Curtain Material makes the best and in fact the only Durable Curtain. Prices Very Reasonable.



Largest and Best—More Exhibits Than Ever—All Parts of the Country Represented—Big Southern Representation—Atlanta a Model Host—A Grand Success.

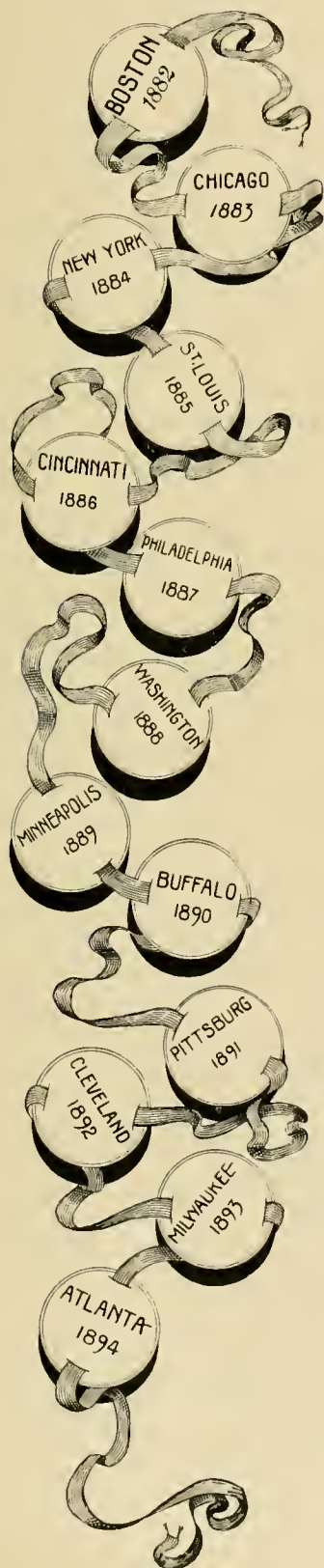

Cotton jest a-rollin' in—  
Haystacks risin' high;  
Corn a-pilin' up the bin,  
Cider when you're dry!  
Hills' and valleys full o' song—  
Whisperin' of fall;  
Fiddle going all night long—  
Balance—balance all!  
—Atlanta Constitution.

Some members had predicted that the unusual distance from most parts of the country to the convention meeting point, would this year have a marked effect upon both attendance and number of exhibits. The importance to which the association has grown was never more strongly evidenced than in the large number present when the first session opened. The very fact that so many delegates had never visited a portion of our country of which they had heard so much, led many to start a day or two earlier than usual, and the night before the opening day found the hotels completely filled. Late evening trains of Tuesday and early morning trains of Wednesday still further swelled the crowd. The weather was simply perfect and the delightful ride out Peachtree street on the swiftly moving cars of the Traction Company's line presented a panorama of beautiful grounds and spacious

residences, while the soft clear balmy air put everyone at their best.

The arrangement which provided quarters for exhibits and business sessions under one roof was greatly appreciated by all, and it was with evident reluctance the delegates were called from the imposing appearance of Machinery Hall to gather in the annex for the first session.

At the usual hour of 10:30 President Payne called the meeting to order and declared the convention open. Never before has so large a body been present, nor so large a proportion of prominent officials.

THE ADDRESS OF WELCOME

was given by Governor Northen, who extended the hospitality of Atlanta in graceful, well chosen words expressed in heartiest terms. He said in part:

I apprehend that many of you have never before visited this state and possibly not the south. We are glad to have you here, that you may know for yourselves, the attractive advantages of the south.

This ideal, balmy day is fully representative of our light and health-giving climate.

Many of you, I dare say, expected to find us living in the tropics.

It may surprise you to know that the hottest day I have experienced in five years, I found last June in Toronto, Canada, and the next highest temperature, last August, in Nebraska.

We are glad to have you personally, know about the variety, abundance and richness of our agricultural products, our mineral, timber and industrial resources.

We give you especial welcome upon these special grounds, so that, impressed, as you will necessarily be, by the preparations in progress for the coming Cotton States and International Exposition, you will not only advertise abroad its possibilities and its attractions, but you will return next year and bring with you your friends to look upon its splendid magnificence and share the benefits to come from its exhibits.

We receive you gladly into our state because we want you to know our people better. Warm-hearted, hospitable, genial, cultured, progressive and true, the equals of any among the civilized nations of the earth.

Again, we are glad to have you visit us, that you may know the financial and business conditions of the south.

Did you know that during the recent financial distress that came upon our common country, we had fewer bank and business failures at the south than in any other section of the Union? Did you know that the south owes less money than any other division of states?

The average land mortgage indebtedness for fourteen states at the south is only \$33,000,000, while the same indebtedness for fourteen states at the north amounts to \$334,000,000.

The average annual interest for these states at the south on this mortgage indebtedness is \$2,600,000; for the corresponding states at the north it is \$21,900,000. The average per capita of this indebtedness for the south is \$25, while for the north it is \$129.

Knowing these conditions, we are glad to have you visit our section with a view to the further development of your interests at the south. Electric street railways have made wonderful progress in this section. We now have at the south 1,611 miles completed and projected, calling for an investment of \$71,080,000 to equip them. This has all been done, too, within the last six years.

We welcome you, because you are an organization of thorough business men, come to consider the business conditions about you for the advancement of the common good.

More than all, we give you greeting, because we believe you to be the strong factor for the advancement of the business interest and the civilization of the times that has given spirit to our progress for the last quarter of a century.

Standing then in this distinguished presence, in view of the conditions you find here and the intelligence and purposes you bring with you, speaking for Georgia and the entire south, I give you most cordial greeting and glad welcome to our state and among our people.

#### PRESIDENT PAYNE'S RESPONSE.

At the conclusion of the governor's remarks President Payne made the following response:  
Your Excellency:

For myself, and on behalf of the American Street Railway Association, permit me to return our most sincere thanks to your excellency for your very cordial welcome to your beautiful city of Atlanta.

I am sure that we shall carry away with us on our return to our several homes, such remembrances of the generous hospitality of your citizens that we shall become missionaries in our various localities in the interest of the great exposition for which you are making such magnificent preparations.

The street railway business is so closely identified with all the material welfare of our large cities that I am sure your citizens will be interested in the splendid exhibit of all that enters into the equipment of a first-class street railroad, now to be seen in this building, and all your good people are cordially invited to visit and inspect the same.

Secretary Richardson read letters from C. B. Holmes,

H. M. Watson and Wm. H. Sinclair, regretting their inability to be present.

President Payne then delivered the following address:

#### PRESIDENT'S ADDRESS.

#### GENTLEMEN OF THE ASSOCIATION:

For your partiality in electing me to the office of president of the association, I desire to return my most heartfelt thanks.

It is hardly necessary for me to say that since our last meeting the street railway business has suffered, in common with all other enterprises, owing to the financial stringency and business depression which has prevailed in all parts of the country. These conditions, however, have not been without lasting benefit to the interests which we represent; I think we have all studied more thoroughly to bring about economies in operation, to limit construction of new lines into unproductive territory, and in every way to bring our business to a more healthy basis; so that from that point of view there is compensation for the depression through which we have passed.

I presume it is the common experience of all that we are on the up grade and I confidently anticipate a slow but gradual return to normal business conditions. The resources and characteristics of the American people are such that they cannot long continue in a state of either mental or financial depression.

During the transition period from animal to electric power on the tramways of our country, it was but natural that the proceedings of the annual meetings of the association should be largely taken up with the consideration of the application of electricity to transportation purposes. Now that we may fairly consider such application as an accomplished fact, I think our attention should to a greater degree, be turned to a comparison of views regarding the practical operation of our several roads.

The substitution of electricity for animal power has elevated the business to a higher plane. Street railways have become as essential to the prosperity of our metropolitan cities as the steam railways to the country at large.

Having had practical experience in the management of both these methods of transportation, I can fairly say that the duties of a manager of a street railway equipped for rapid transit are more vexatious than, and require quite as much ability, intelligence and application as those of one in charge of a steam railway. The steam railway manager makes his time tables, publishes them, and the people are expected to, and do suit their convenience to the same. Not so with us. We are expected to make our time tables conform to the convenience of each individual separate passenger who desires to be transported, and a car is expected to be at each and every corner at the identical moment when the passenger is ready to be carried.

Again, the steam railway manager has to encounter legislatures and legislation but once in two years, or at the most once in each year, and that during a short period in the winter only; while the life of the street rail-



way manager is made unhappy, to say the least, by the legislative bodies in cities, which are practically in continuous session.

The American capitalist is quick to discover promising fields for the investment of capital, and I think it is safe to say that never in the history of our country has there been a more rapid development than has come from the application of electricity to transportation purposes. In the anxiety to secure franchises and to reconstruct street railways, very excessive valuations have been placed upon and paid for the right to operate by electricity in our large cities. This has led the representatives of the people to believe that there is a present value attached to franchises far beyond that which the facts will sustain.

Consequently these conditions have led to a fruitful field for the legislator as well as for the assessor, from whose tender solicitude for the welfare of the people the street railways, whose prosperity contributes so much to the general good, have suffered.

The interest, as well as the inclination of most managers tends toward giving as liberal and good a service to the public as the patronage will justify.

Transfers, and to what extent they should be granted, commutation and its effects upon earnings, and the relative earnings of cars operated on long and short time headway, furnish fruitful topics for discussion and comparison of views. These and many other practical subjects which will occur to you, I think should receive your attention, and I believe their consideration will be not only of great interest, but of material advantage to us all.

Your executive committee have set apart one morning for executive session, at which time I trust we shall have full and free exchange of views bearing upon matters to which I have referred and many others affecting the practical operation of our roads.

The question of insurance has become a perplexing one. In many instances the larger systems find it very difficult to obtain insurance in sufficient amounts to cover their risks, and I think the common experience is that rates have increased to such an extent as to be so burdensome as to justify us in considering the propriety of organizing a mutual insurance association.

I cannot close without referring to the great loss which we have suffered from the removal by death since our last meeting of two of our most prominent and active members.

Mr. William Richardson, of Brooklyn, N. Y., had been identified with the association since its organization. All will recall the great interest which he took in our deliberations, and I am sure that we all feel a sense of personal sorrow that we shall no more have his wise counsel. His life's work, so far as business activities were concerned, was completed, and he was looking forward to that quiet and peaceful ending of his days to which a long and active life had entitled him.

Mr. William J. Stephenson, of Washington, D. C., first vice-president of the association, was, to my mind, an almost perfect type of an aggressive, forcible, intelligent

business man. He had been for a considerable time engaged in maturing plans for the introduction of the underground trolley system upon his road. To this end he had succeeded in obtaining the necessary legislation from congress, and his plans were very far matured toward the actual commencement of the work of reconstruction. We cannot but regret that he has not lived to consummate the plans which he had so ably matured. Mr. Stephenson was looking forward with the greatest interest to this meeting, and I am sure that I but reflect the sentiment of every member in expressing my sorrow and regret at his untimely taking off.

The report of the executive committee was a carefully prepared document, as follows:

REPORT OF THE EXECUTIVE COMMITTEE.

ATLANTA, GA., October, 17, 1894

TO THE AMERICAN STREET RAILWAY ASSOCIATION.

GENTLEMEN:—Your Executive Committee respectfully submits the following report:

MEMBERSHIP.

The hard times affect the street railway business as surely as they do any other. The fare is so small—only a nickel—that one of the unthinking public is surprised when he learns for the first time that business depression affects the receipts of a street railway company. The fact is there is no more accurate test or measure of the state of the business of the country than the varying income of a street railway company, showing, with absolute accuracy, the state of business activity or depression in the community. Business in general, during the last year, has been bad, and the street railway business, in particular, has suffered, several of the member companies having gone into receivers' hands, while consolidation still continues to be the trend of the times. While the year has been a hard one, the business outlook is encouraging, and we look forward with confidence to a successful year's business.

At the opening of the meeting in the city of Milwaukee there were 197 member companies. At that meeting, and during the year, the following companies have joined:

- Camden, N. J.—Camden, Gloucester & Woodbury Railway Company.
- Charleston, S. C.—Enterprise Railroad Company.
- Columbia, S. C.—Columbia Electric Street Railway, Light & Power Company.
- Helena, Mont.—Helena Rapid Transit Railroad.
- Macon, Ga.—Macon & Indian Spring Electric Street Railway Company.
- Mobile, Ala.—Mobile Electric Light and Railway Company.
- Nashville, Tenn.—Nashville Traction Company.
- New Britain, Conn.—Central Railway and Electric Company.
- Newburgh, N. Y.—Newburgh Electric Railway Company.
- New Orleans, La.—New Orleans Traction Company, Limited.
- Paterson, N. J.—Paterson, Passaic & Rutherford Electric Railway Company.
- Poughkeepsie, N. Y.—Poughkeepsie City & Wappinger's Falls Electric Railway Company.
- Rockland, Me.—Rockland, Thomaston & Camden Street Railroad Company.
- Tampa, Fla.—Tampa Electric Light & Street Railroad Company.

The following changes in the names of members have taken place:

- Brooklyn, N. Y.—Brooklyn, Queens County & Suburban Railroad Company, in place of Broadway Railroad Company.
- Carbondale, Pa.—Lackawanna Valley Rapid Transit Company, in place of Carbondale Traction Company.
- Kansas City, Mo.—Kansas City Cable Railway Company, Consolidated, in place of Kansas City Cable Railway Company.
- Nashville, Tenn.—Nashville Street Railway, in place of United Electric Railway.
- New York, N. Y.—Metropolitan Street Railway Company, in place of Houston, West Street & Pavonia Ferry Railroad Company.
- Norwalk, Conn.—Norwalk Street Railway Company, in place of Norwalk Horse Railroad Company.

Washington, D. C.—Belt Railway Company, in place of Capitol, North O Street & South Washington Railway Company.

The following changes of names of companies by substitution and consolidation, the new companies succeeding the old, have taken place:

Jersey City, N. J.—Consolidated Traction Company, in place of the Jersey City & Bergen Railroad Company and the New Jersey Traction Company, of Newark, N. J.

Lawrence, Mass.—Lowell, Lawrence & Haverhill Street Railway Company, in place of Haverhill & Groveland Street Railway Company and Merrimack Valley Street Railway Company, of Lawrence, Mass.

San Francisco, Cal.—Market Street Railway Company, in place of City Railroad Company, and Ferries and Cliff House Railway Company.

St. Louis Mo.—Union Depot Railway Company, in place of the Benton-Bellefontain Railway Company.

The following companies have withdrawn; several of them having gone into the hands of receivers, or leased to other companies, and nearly all of them being very weak financially

Alexandria, Va.—Washington, Alexandria & Mt. Vernon Railway Company.

Amsterdam, N. Y.—Amsterdam Street Railroad Company.

Birmingham, Conn.—Derby Street Railway Company.

Cincinnati, O.—Mt. Auburn Cable Railway Company.

Dover, N. H.—Consolidated Light and Power Company.

Erie, N. Y.—Erie Electric Motor Company.

Findlay, O.—Findlay Street Railway Company.

Lancaster, Pa.—Lancaster Street Railway Company.

Lyons, Ia.—Clinton and Lyons Horse Railroad Company.

Nashua, N. H.—Nashua Street Railway Company.

New York, N. Y.—North and East River Railroad Company.

Peoria, Ill.—Fort Clark Horse Railway Company.

Raleigh, N. C.—Raleigh Street Railway Company.

Yonkers, N. Y.—Yonkers Railroad Company.

As a result of the foregoing changes, the membership now numbers 187 companies.

#### THE TECHNICAL PRESS.

It is with unfeigned pride that we regard the journals devoted to the Street Railway business. We desire as a committee to acknowledge the services offered this association in the earnest endeavors to increase the membership, and honestly express an appreciation of the efforts to make their publication the peer of any other trade papers in the land. The souvenir editions show fine character of typography, high grade of illustration and thoughtful care in composition. We heartily wish them all possible success in their earnest endeavors to excel. While we do not desire to make any particular distinction in our reference to the technical papers, we feel called upon to express our thanks to Mr. C. B. Fairchild, editor of the Street Railway Journal, for his personal efforts in the interest of the association in his contact with the street railway men of the country, and for the benefit conferred upon the fraternity in the production of the book, entitled "Street Railway Trams."

#### SPECIAL REPORTS AND PAPERS.

The special reports and papers that have been prepared cover a wide range of subjects, and express the latest thought and practice in the business.

#### EXPOSITION.

The Exposition of Street Railway Supplies will be found of unusual interest, the product there displayed being the latest expression as to the needs of a street railway, especially if the motive power be electricity.

#### STREET RAILWAY LAW.

Judicial decisions and opinions have been issued during the year, and constitute parts of volumes X. and XI. of "Street Railway Law," as follows:

1893.

November.—George Rouser vs. North Park Street Railway Company.

December.—W. L. Allen vs. Birmingham Railway & Electric Company.

1894.

January.—John C. Bleil vs. Detroit Street Railway Company.

February.—George A. Jennings vs. Tacoma Railway & Motor Company.

March.—Otto J. Lang vs. Houston, West Street & Pavonia Ferry Railroad Company.

April.—Catherine King vs. Second Avenue Railroad Company.

May.—James E. Johnson, et al., vs. Reading City Passenger Railroad Company.

June.—James E. Morgan vs. Jersey City & Bergen Railroad Company.

July.—Mary Flanagan vs. People's Passenger Railway Company.

August.—Lena T. Cleveland vs. Bangor Street Railway Company.

September.—State of Minnesota vs. Frank S. Hoskins and Dow S. Smith.

October.—Youngstown Street Railway Company vs. Elmer Hovestick and 115 others.

#### AMERICAN STREET RAILWAY DECISIONS.

The second volume of the work started some years since, entitled American Street Railway Decisions, has been printed, and is now in the binder's hands, and will be issued to subscribers during November.

The editors have copy in hand to push the work to a speedy conclusion, and they promise to bring the matter down to date as rapidly as possible, consistent with accuracy. Companies that have not already subscribed for the work are reminded to send in their subscriptions. The price is \$5 a volume, net, delivered.

#### PROPOSED AMENDMENTS.

Two proposed amendments, one to the Constitution, the other to the By-Laws, are herewith submitted, and, though it would not be binding in any sense, we should be pleased if a vote were taken at this meeting, without debate, that we might ascertain whether the judgment of the association is in accord with that of your committee on both subjects.

The proposed amendment to the Constitution is to provide for the admission of individuals and companies, not street railways, as associate members, under certain conditions; such character of membership having been found conducive to the general welfare of kindred associations.

The proposed amendment to the by-laws has in view morning sessions only; providing for less exhaustive meetings; for more opportunity for social enjoyment, as well as for opportunity to examine the display at the exposition, which has become so important a feature of our annual meetings.

#### CONSTITUTION.

##### MEMBERS.

Article III of the constitution shall be amended so as to read as follows:

Section I. There shall be two classes of members—active and associate.

Section II. Active members shall be American street railway companies, or lessees, or individual owners of street railways, and each member shall be entitled to one vote by a delegation presenting proper credentials.

Section III. Associate members shall be individuals, or firms, or companies not embraced in section II, who shall have been recommended by an active member. Associate members shall not be entitled to vote.

##### BY-LAWS.

Article VII shall be amended by the substitution of the word "Tuesday" for "Wednesday," and by the addition of the following words to the first sentence, namely: "And shall continue four days."

##### OBITUARY.

William Richardson departed this life December 31st, 1893, in the seventy-first year of his age. He was for many years the president of the Atlantic Avenue Railroad Company, of Brooklyn, from which position he retired the early part of last year. He began his street railway experience with the Dry Dock, East Broadway & Battery Railroad Company, of New York, and was acting president of that company at the time of his death. He was a regular attendant at the annual meetings of this association, and always took a lively interest in its welfare. He was an ideal companion in his home; of the strictest integrity in business, of untiring energy and high ambition to excel in all he undertook to do, and withal a sincere friend. We shall miss his inspiring presence.

John H. Dalzell died May 29th, 1894. He was the President of the Pittsburgh, Allegheny & Manchester Traction Company, and a man of large influence in the community in which he lived. He was blessed with exceptional foresight, and determining early to make a success in

life, he succeeded by his indomitable pluck, energy and earnest purpose in attaining a position of large prominence. His loss is mourned by a large circle of friends.

Allen Tindolph died July 27th, 1894, aged 52 years. He was president of the Vincennes Street Railway Company, and was prominent in other business enterprises in the place in which he lived. He was a man who stood very high in the esteem of his fellow citizens by reason of his sterling qualities of character. He was a Christian gentleman, a public-spirited citizen, and a model in his home.

For the first time in the history of the association, an officer has died during his incumbency. William J. Stephenson left the sphere of his earthly activities on August 31, 1894. He was the president of the Metropolitan Railroad Company, of Washington, having been previously connected with the Columbia Railway Company of the same city in a like capacity.

He was energetic, enterprising, in short a typical progressive American. Always enjoying the best of health, with ruddy clear complexion, of commanding appearance, having convictions and the courage of them, a ready speaker, always with something to say, reinforced with deep interest in this association, his was a familiar figure and voice at the annual meetings.

We shall sadly miss our friends and companions.

Respectfully submitted,

H. C. PAYNE,  
LEWIS PERRINE, JR.,  
E. S. GOODRICH,  
THOS. H. McLEAN,

Committee.

W. J. RICHARDSON,  
Secretary.

#### THE TREASURER'S REPORT

showed receipts from all sources for the year to be \$8,290; expenditures \$8,196, leaving a balance of \$94 on hand.

The first report presented was on the Best Method of Treating Accidents and Complaints.

#### THE BEST METHOD OF TREATING ACCIDENTS AND COMPLAINTS.

By P. M. Dyer, of Claim Department of North and West Chicago Street Railroads.

Among the subjects coming to the attention of the general manager, none is more replete with perplexity and difficulties than the disposition of personal injury claims. Expense of operation can be approximated; cost of construction estimated by the engineer or architect; but when and where accidents will happen and what they will cost the company, can never be predicted. By the aid of modern inventions the cost of operation has been lessened; but this gain is threatened by the additional expense incident to the increased number of accidents on street railroads operated in the crowded thoroughfares of our large cities. It is my purpose to explain to you in what manner the North and West Chicago street railroads attend to personal injury cases, commencing with the accident and following the theme to the final disposition of the claim.

These two corporations carried 167,000,000 of passengers during the year ending December 31, 1893 and upon the claim department devolves the duty of investigating all accidents and the making of settlements, or the preparation of the defense, in all claims that spring from this great traffic. One claim department does this work for both roads.

The working force consists of a medical staff, and a sufficient number of investigators, all under the direction of the chief adjuster, who reports to the general counsel of the two companies.

For the purpose of this article the work of the claim department may be divided into three periods, each separate and distinct from the others, as follows:

- First, investigation.
- Second, negotiation.
- Third, litigation.

First, as to investigation. The work of this period begins immediately after the accident and continues until there has been secured a full and accurate account of the accident, with reliable information as to the nature and extent of the injuries to person. Employees have been

instructed to notify the claim department of the occurrence of an accident on car or train, giving circumstances of same, nature of injuries to, and residence of the injured, and, as far as possible, to secure the names of the witnesses. When this has been accomplished, and the injured one has been placed in the charge of a physician, or the police, the car or train may continue its journey. In the meantime, a representative of the claim department will proceed with all possible dispatch to the scene of the accident.

If the injured party has not yet been removed, he must see that conveyance is provided to the hospital or to the home. These companies usually bear the expense of temporary medical care and transportation, without regard to liability, believing such attention is appreciated by the injured and the community at large. In all cases of personal injury it is the duty of the medical staff to secure the privilege of an examination, the physician making same to avoid any assumption of responsibility for the treatment, but to fully ascertain the nature and extent of the injuries, and obtain, if possible, a concurrence in his report by the attending physician. All employees witnessing accidents are required to make written statements of the circumstances of the same on printed forms provided for that purpose, attaching their names, and place of residence of all witnesses. This report must be completed and given to the foreman before the employe finishes his day's duties. These reports are forwarded to the claim department without delay, and when received, circular letters containing printed interrogatories are sent to each witness. If the seriousness of the accident demands it, interviews are had with the witnesses. That the claim department may be kept fully advised, from time to time, as to the conditions of persons injured on these roads, they are occasionally visited during the period of recovery by the investigators assigned to those cases. In Chicago all hearings before the coroner are had immediately after the accident, and the verdict of the coroner's jury is usually rendered on the day following the deaths. It is the policy of these companies to secure the presence of their witnesses at the hearing before the coroner, and obtain stenographic minutes of the proceedings. Thus in a comparatively short time, the claim department will have collected much information as to the condition of the injured, and the circumstances of the accident.

We may now consider the work of the first period completed. The reports relating to an accident could now be filed away, perhaps forever, if it were not for the industry of some claim lawyer, or other hustler, who persuades the injured to make a demand on the company for compensation.

The making of a claim leads us to a consideration of the second period, that of negotiation. Demand being made for compensation, it becomes the duty of the chief adjuster to place before the general manager, or general counsel, all facts within his knowledge bearing on the claim, for a decision as to liability, and the naming of the maximum sum to be paid, if a settlement is deemed advisable, the claimant being promptly informed of the decision.

As to the negotiations preceding a settlement, I will say but little. They are usually conducted by the chief adjuster on the part of the company. If not successful, the period of negotiation will end usually to be followed by that of litigation, the third and last.

After the commencement of a suit, all witnesses are again located by the claim department, and thereafter located at stated intervals until the time of trial, and if possible, additional witnesses are found to strengthen the defense.

Success in defending suits arising from personal injuries largely depends on the character of the work done during the period of investigation. The officers of these companies believe in the thorough investigation of all accidents; if possible, the full settlement on a reasonable basis of all valid claims; in vigorously contesting fraudulent demands; and that prompt settlements are for the best interests of their companies.

In conclusion, I will say that the time is at hand when all railway corporations must be prepared to resist claims in a large percentage of their accidents. To promptly prepare to do this it is the part of wisdom, when considered from a financial stand point, usually the determining consideration in corporate management.

#### DISCUSSION.

Mr. Payne, of Milwaukee, stated his method was practically the same as the one described, but their experience was that a company stood very little chance before a jury in any event, hence their effort is to definitely ascertain the extent of injury and settle out of court as early as possible.

To the question as to what extent a company should go in furnishing relief, Mr. Dyer replied: "First ascertain the liability, and if it appears that the company is not legally liable it then becomes a question of

charity, at the same time exacting a release. A great deal of money is paid out where there is no legal liability whatever." A peculiar—and as all will bear witness, a very rare case—recently was handled by Mr. Dyer. A man, who had lost a leg on the company's car, came in and stated the accident was entirely his own fault and the company in no way to blame. He even offered to make affidavit to that effect and would sign release. He, however, asked as a matter of charity for sufficient money to purchase an artificial limb, which request was granted. The West Chicago Street Railroad used an insurance company for one year in 1890 and '91, but have not since.

Mr. Payne quoted a case of misplaced charity, where the company was in no way liable, and sent the patient to a hospital and paid the expenses, amounting to about \$1,000. When the party recovered he entered suit and secured damages in the sum of \$7,800, the plea being largely that the company had practically admitted its liability, having paid the hospital bills.

Lunch was served in the building immediately after the morning session and members devoted two hours to an inspection of the exhibits described in detail elsewhere. The display was a highly creditable one, and again emphasized the fact that the day of fake and impractical

cut flowers were scattered in profusion. Early in the evening an eloquent address of welcome was given by the president of the club, Major Livingstone Mims, and was frequently interrupted by applause. Dancing followed, in which the superb qualities of the ball room floor were fully appreciated. Elaborate refreshments were served throughout the evening, in the banquet hall, and reflected great credit on the club's chef. There were present many of the leading members of Atlanta society, and the beauty of the ladies, and the elegance of their dress, more than met the visitors' expectations of Southern loveliness. The function was one of the most noteworthy in the history of street railway conventions, and will pass into history, as a never to be forgotten event.

#### THURSDAY MORNING.

An executive session was held on Thursday morning.



LADIES' CAFE.

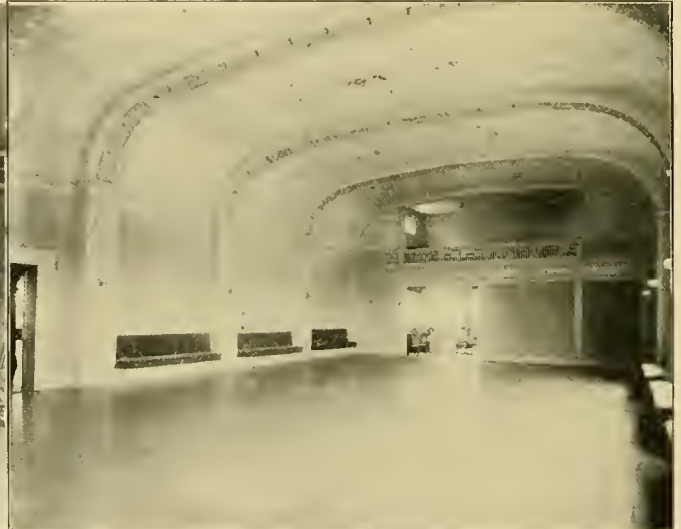

BALL ROOM.

inventions is passing. Every exhibit possessed merit, and the entire floor space of Machinery Hall was filled. Exhibitors, too, were early in place and ready to show and describe appliances, thus saving much valuable time which has in years past been worse than wasted. That their efforts were appreciated is evidenced in the careful inspection accorded by the delegates. At four o'clock, special cars were taken, starting from Machinery Hall, and an inspection given of the lines and power house of the Consolidated Company, where the mammoth new engine of the Rankin-Fritsch Company was greatly admired.

#### WEDNESDAY EVENING.

Wednesday evening was very appropriately set apart to the acceptance of the reception tendered the association by the Capital City Club, the fame and position of which, as one of the leading social factors in the South is national. The club house is spacious and most thoroughly well appointed, and the guests arrived early and remained until a late hour. Over one thousand were present, but there was no crowding or confusion. Tropical plants and

The subject of transfers and commutations was considered, the general impression being that the privileges should not be extended further than was absolutely necessary. The subject of the formation of a street railway mutual fire insurance company, was also taken up, and on motion of Russell B. Harrison, the incoming officers and executive committee were appointed a committee to report on the subject.

On motion of H. M. Littell, of New Orleans, Messrs Littell, Perrine and Connette were appointed a committee to wait upon the officers of the Underwriters' Association of the South, with a view to securing better conditions and rates for insurance of street railway properties; the office of the association being in Atlanta. Thereupon the executive session adjourned. The convention next took up the report "can the T rail be satisfactorily used in paved streets." The paper prepared by S. Hendrie, of Detroit, was in his absence, read by the chairman of the committee, Joel Hurt, of Atlanta. This paper appears in full on page 601 of this issue.

On motion of T. H. McLean, the nominating committee

was appointed, consisting of Messrs. McLean, Connette, McNamara, Baumhoff, Breed, Semmes and Rugg. Invitations were tendered for the next place of meeting from Cincinnati, Philadelphia and Montreal. This closed the morning session.

The afternoon of Thursday was spent very pleasantly in a street car ride around the city, and Thursday evening came the banquet, an account of which will be found elsewhere.

FRIDAY MORNING.

Only a few members attended the opening session this morning, but they strolled in during the morning until the time of the election of officers, when there was comparatively a full representation. The first paper was on City and Suburban Electric Railways, by E. C. Foster, which appears on page 603. Then came the interesting report of Russell B. Harrison, on the T Rail Construction at Terre Haute, Ind.

**"SMOOTH, DURABLE AND SUCCESSFUL T RAIL STREET RAILWAY TRACK CONSTRUCTION IN PAVED STREETS."**

A Report to the American Street Railway Association on the T Rail Track Construction of the Terre Haute Electric Railway, of Terre Haute, Indiana, by Russell B. Harrison, M. E., M. S., President of the Road.

MR. PRESIDENT AND GENTLEMEN OF THE CONVENTION:

It gives me pleasure to respond to the request and invitation of the American Street Railway Association, extended last year at the Milwaukee convention, to make a report at the Atlanta convention, on "The T Rail Track Construction of the Terre Haute Electric Railway." Not alone from the fact that it is very gratifying to have so influential a body as the American Street Railway Association thus recognize the pioneer and successful work of the Terre Haute road in the important field of track construction, but more specially from the standpoint that, having given several years study to street railway track construction—not following as others lead—but working on the problem with new and original ideas, I believe the presentation of the results that have been secured, and at the same time calling attention to the defects and imperfections demonstrated by our experience, will not only prove of great value and interest to the members of the association, in showing how T rail track construction may be successfully laid in paved streets, with the hearty approval of the public, but will give the members a standard to follow that will enable them to save thousands of dollars in expensive experience and in costly experiments. If but a small part of my expectations in this respect shall be immediately realized, the seed will be sown and will produce a great harvest, bringing ample reward for our efforts and work on the problem, and attention to this paper.

The present standard of "all steel" T rail track construction of the Terre Haute Electric railway, not only has no equal in this country, but is so far in advance of anything yet attempted in the way of street railway track construction, that I feel a brief outline of our work on the problem prior to reaching the present standard, will not only not be out of place, but will prove of real interest.

I am aware, gentlemen, that these are strong words to be used in connection with our present track construction, and that my opinion may not be immediately shared by every member of the association, but I am confident that all members making an actual inspection of the track will share my opinion as to its smoothness, solidity, durability, permanency and general merits, and the great advantages and public popularity of the smoothly finished asphalt and brick paving laid in connection with it.

I realize that, with the track in Terre Haute, it will be difficult, by a paper, to explain intelligently how the track was laid and show its many advantages, but I shall make the attempt with the aid of some photographs, and supplement the effort by inviting the members of the association to visit Terre Haute and make a personal inspection and examina-

tion of the several types of our T rail track construction, knowing that the eye is better than the ear in passing judgment on as perfect a street railway track construction as has been laid up to the close of the year 1894.

Terre Haute is an anomaly among the cities of this country, on the subject of street railway track construction. It is the only city that would not permit girder or grooved rail in its streets, and would make as great a fuss now on the subject as the average city would do, if an attempt were made to lay T rail track. This will seem to the members of the association a strange condition, but to the company it is a very pleasant one, making the company's relations with the city on the subject harmonious, and permitting the road to secure, with popular approval, the best and most durable form of rail, at the least cost.

This feeling, the approval by the public of a T rail did not exist at the start, but was brought about gradually by tact and good judgment, assisted by the greatest of all teachers, experience.

It would not be in existence to-day if the management of the road had not all times realized that public opinion and the approval of the public were valuable assets to a street railway company, and worth every earnest effort to hold and maintain. Our motto has been, not, how cheap, but how good we could construct our tracks in the streets. The public have appreciated our efforts and sustained us loyally.

I shall not have time in this paper, nor do I feel that it would prove interesting, to go into the details of my studies and investigations concerning rails, foundations, joints, paving, ties, etc., or into the details of the conclusions that have caused me to adopt the present "all steel track" as our present standard.

The time at your disposal is limited, and what you want is results, and I shall endeavor to lay investigations, theories and speculations aside in this paper, and as briefly as possible make a report that will give you also results in smoothness of track, durability of construction and economy of operation, if you will follow our example and advice.

There has been in the past too much attention paid to motors, generators, cars, power houses, etc., and too little to the foundation for successful and economical operation—a perfect track.

The development of electricity as a motive power for street railway service, was very rapid, and it is only natural that the inexperienced should be misled in their hurry to change power and have an electric road that would make them very rich in a year or two.

The agents of many electric concerns were chiefly interested in selling apparatus, and with the apparatus sold the future of the roads and their ability to earn a profit, did not enter into their calculations.

Is it any wonder, then, that many roads should find after a year or two of experience, that the track was too light for the cars and motors, and the cars and motors were too heavy for the track, and that both were worn out and required rebuilding at a time when the great panic had reduced traffic to the lowest point. Light and abused track and worn out cars and motors, coupled with reduced traffic, have brought to too many roads the unwelcome guest—the receiver.

Many of these roads, through receivers, or in their reorganized condition, are profiting by experience, and giving proper and careful attention to the track.

It seems strange to me that street railway track construction should drift so far away, in theory and practice, from steam railway track construction. One had but to study the wonderful display showing the development of track construction in the Transportation building, at the World's Fair, to acquire a liberal education on the subject.

The Terre Haute road has, indeed, had a fortunate experience. Its management early realized that successful track construction should approach, as far as possible, and not deviate from, further than necessary, the best steam railway track construction. So, to-day, the Terre Haute road is an all T rail road, and every block of track in paved streets of so durable a character that it will last for years, with a minimum of repairs.

Terre Haute, although a small town at the close of the great civil war was very enterprising, and determined to have a street railway. A company was incorporated for this purpose, in 1866, with ample capital, and commenced to lay track early the following year, when one and a half miles were completed. The operations of the company and its trackage increased as the years rolled by, like other horse or mule railways. Its earlier operations are not interesting in connection with this paper, as they were after the manner of other roads, and of a type familiar to all street railway men.

It is an interesting fact, however, in connection with the present low price of steel, that the side bearing flat iron rails purchased by the company in 1867, cost \$108 per ton. Those rails were used about twenty years, and then 38-pound girder rails were substituted.

The franchise of the company does not contain any requirements as to the style, character or weight of the rails. While there has been no expression from the public on the subject, the management feared that the general and popular prejudice against the use of T rails in the streets would appear in Terre Haute. They therefore hesitated about so radical a change, but appreciating the good results that would come from the use of such a rail, they concluded to place a trial order.

No publication was made of the fact that they intended to use T rail. The first T rail laid by the company was on South Third street, and in the fall of 1890. This rail was laid preparatory to changing the motive power from horse to electricity. The management proceeded to make plans to lay this track with caution, and fear as to the way the public would receive it.

The old girder rail on Third street was taken up, new ties distributed, and when everything was ready the T rail was distributed in a matter-of-fact way, as if it was the only rail that could be used, and a force of men put to work in laying them. The mayor of the city came around shortly, reports having reached him as to the company laying a steam railway track, and when he saw the reports were true, said, with some excitement, "What are you doing here, putting a steam road in our streets?" The superintendent, who was on the spot, was equal to the emergency, and replied pleasantly, but earnestly, that the track was being built for an electric railway. The mayor replied that that could not be the case, as the rails were steam road rails. The superintendent then informed him that these T rails were the only rails adapted for the successful operation of electric railways, and while it appeared to be the steam road rail, it was in reality very much lighter (the section being 40-pound T) than a steam road rail. Further explanations satisfied the mayor, and convinced him as to the merits of the T rail. In a short time he not only became interested, but enthusiastic, and brought councilmen to see the rail, and explained to them its advantages for electric street railway service. They in turn brought prominent citizens and others to look at it, and explained these advantages.

Thus, by tact and management, and perhaps some good fortune at the start, the mayor, council and the public welcomed the T rail, as an improvement, and a necessity in securing the electric street railway service, which they greatly desired, and the road was happily started in the right way with T rail, without opposition, adding a great value to the plant. The only fear and worry was by members of the company. They were timid as to the T rail, and feared that it would not be successful in paved streets. From this good start it has been a steady march of improvement.

A description of the laying of this first T rail track will prove of interest. It was a 40 pound T rail, laid on oak ties 3 inches by 7 inches, by 7 feet, with 3 feet space from center to center. The rails were laid without proper regard to having the end of the rail rest on a tie.

Planks 2 inches by 6 inches by 13 feet were laid on both sides of the rail. On the inside the planks were nailed to the ties, and on the outside blocks were nailed to the ties to raise the plank to a level with the rail to provide vehicles an easy crossing. Ordinary flat splice bars were used with the rails. The rails were bonded with  $\frac{3}{8}$  galvanized bond wire, with a single bond to the joint. They in turn were wired and soldered to a supplementary wire of  $\frac{1}{4}$  inch galvanized stranded iron wire; each alternate joint being soldered and wired from both rails of the track. In the single track the supplementary wire was in the center of the track, and in double track between tracks. The track was covered in with good gravel.

One year's experience demonstrated that planking was unnecessary; that gravel which is found in great abundance under and about Terre Haute made—with a little clay which is found above it—a superior substitute for the plank, and protected the rails better in permitting vehicles to pass along, and to cross the track easily and without injury. This substitute only required occasional attention in filling up low spots to maintain a level roadway. In two years the planks were badly decayed and warped up at the end, and as the track was thoroughly overhauled at that time the planking was taken up and gravel substituted.

At the end of two year's service of the track, it was found in making repairs that the galvanized iron supplementary ground wire was rusted out, and gone for various distances, making a return circuit an impossibility, and we only had the rails to depend upon, which in themselves, for this purpose, are not sufficient. This trouble not only reduced the efficiency of the light circuits in the cars, but caused frequent burn outs of the armatures and fields. It grew to such an extent that it was found necessary to re-bond this track, and it was decided at the same time to dig up and repair the entire track and increase the number of ties by  $\frac{1}{3}$ , and at the same time give careful attention to hav-

ing the ties under and properly supporting the rail joints. Tinned No. 00 copper wire was substituted for iron as the bond and supplementary wire. Good gravel with a little clay was substituted for the plank along the rail, and the substitute has given very much better service than the planks have ever done.

This section of the road, as re-built, is in daily use now and giving good service.

Our experience with this first piece of T rail track was very valuable in many ways, and enables the management to use the experience thus gained to make many improvements in laying additional T rail track.

It was indeed fortunate that we gained so much experience before laying T rails in paved streets.

The era of street paving did not set in Terre Haute until 1892. This was not because Terre Haute lacked in enterprise and progressiveness, but was because the town was situated on a high bluff fronting the Wabash river, and had, with the gravel sub-soil, good drainage and good streets. When it was decided to pave Wabash avenue or Main street with brick for fifteen blocks, it became necessary for the company to take up its girder rail. Our experience thus far with T rail had been so satisfactory and successful that it was decided to continue its use on a larger and greatly improved scale.

Much study and consideration was given to the problem, the result of which the track was laid as follows:

Rail.—About this time the Illinois Steel Company brought out their 60 pound shanghai T rail, and as it was  $5\frac{1}{4}$  inches high, permitting pay-



All Steel Track, Terre Haute. First Process, Rolling the Roadbed after Excavation.

ing without chairs and direct spiking of the rails to the ties, it was very promptly adopted.

Ties.—Carefully selected oak ties 5 inches by 7 inches by 7 feet, were used.

Foundation.—After excavating for the track, the ground was rolled by a heavy 14-ton steam road roller. Then 6 inches of broken stone was placed in position as a bed and rolled by the 14-ton steam road roller.

Track.—Then the ties and rails were placed in position and raised to grade by tamping broken stone underneath. Spaces between ties were filled with broken stone and raised to position.

Bonding.—Single bonds were used of 7-16 galvanized iron wire, and a supplementary wire of No. 00 tinned copper wire

Paving.—On top of the broken stone, screened sharp sand was placed, and with one inch hose this sand was washed into the interstices of the stone. After drying, the sand was brought up to an even surface by a fresh deposit, and it was then smoothed to even surface and the desired thickness by mould board. Then vitrified bricks were placed in position leaving them somewhat higher than the rail. They were driven in to the cushion of sand by means of hand rammers, with a square piece of boiler plate placed on top of them to force all to the proper level. The sand cushion permitted the bricks to crown evenly from center toward each rail to afford proper drainage. A special brick with one corner cut off, with sloping angle to give space for flange of wheel to run in, was laid next to the rail; those bricks were not the shape of the special nose brick now used, and only set against the lower edge of inside of head of rail. The space between the brick and web of rail was filled with

grouting. Bricks of regular size were laid between. After the bricks had been rammed and rolled to proper position, a grout of boat-screened sharp sand and Portland cement with water, made to such flowing consistency as to permeate all the crevices, was poured over them and by brooms pushed into the openings. When this set, the bricks were solidly united and they cannot be separated, except with great difficulty. A finishing coat of sand was thrown over the entire surface, and traffic kept off it for one week. After thoroughly setting, the sand was swept off and the street opened for traffic. The street, between the tracks and curb stone, as well as between the tracks, is one solid mass of concrete and brick from center of street to curb, and will sustain great pressure. Since this track was laid, our experience with it has demonstrated that it could have been improved in one particular, viz.: the sand and broken stone should have been united with cement into regular concrete, for, we have found since the paving was completed, that the use of the water on the sand did not wash it thoroughly into interstices of the broken stone. In time the sand dried and settled down into the spaces, and while the ties and the paving immediately over them have remained firm and solid, the paving between the ties has settled slightly, without breaking or disturbing, the concrete holding them together. This track, laid in Wabash avenue, the principal business street of the city, has had two years' severe service, and has been thoroughly tested in every particular, and thus practically demonstrated its great success and merit. Vehicles, carriages and wagons can pass along the rail, and turn in or out at will, without jar or wrenching. It can be crossed at right angles, or at any angle, with equal ease and comfort. A continuous traffic over it has caused no perceptible wear, and the cars glide over it without oscillation, as smoothly as when first laid.

Our next experience with T rail construction was in a street paved with asphalt, where a half a mile was laid in the fall of 1892, and a mile more in the spring of 1893.

While asphalt presented some new problems, the T rail, ties, joint plates, bonding and supplementary wire was the same on Wabash avenue. The foundation was improved by making it of concrete, six inches below the ties. This broken stone concrete was also placed between the ties and up to a point to allow space for four inches of asphalt packed into position.

The asphalt was brought up to and in contact with the rail on the outside. On the inside of the rail for the first half mile, the vitrified brick used on Wabash avenue, with corner cut off on a sloping angle, were used to give flange space, and between the ends of the brick, asphalt was used in the regular way. On the last mile the merits of the Haydenville blocks having been brought to our attention it was decided to use them



All Steel Track, Terre Haute. Second Process,—Preparing to Receive the Broken Stone. Setting the Stakes.

both inside and outside of the rail, and while it made a smoother finish to the rail than the brick or asphalt, our experience proves that these blocks do not have the wearing qualities of the brick. This track and asphalt paving are beautiful in finish, and of unusual strength and smoothness. It is a genuine pleasure for passengers to ride over this track, for there is no motion perceptible, except the forward motion.

Our next experience with T rail construction was during the year 1893, in several streets paved with brick. The rail was 60-pound shang-

hai, and rail plates, bond wire and supplementary wire were the same as in the street laid in asphalt. The foundation was six inches broken stone concrete below these ties, and about five and a half inches additional concrete between the ties. It also covered slightly the top of the ties. The foundation for this brick track was further improved by pouring a thin wash of sand and cement over the top of the foundation before placing the sand cushion thereon. This gave the foundation, track, ties and concrete a solid union. The brick paving was laid in a manner similar to that on Main street. Instead of angle cut brick for flange space



All Steel Track, Terre Haute. Third Process, Laying the First Eight Inches of Broken Stone.

Haydenville blocks were placed on the inside of the rails, one and a half inches distant therefrom. The lower part of the space between the Haydenville block and rail was filled with sand concrete, pressed down tight. On top of this an inch of tar was placed. The hollow spaces in the Haydenville block were filled with sand concrete before placing in position, and the space in center of track between blocks was laid with vitrified brick in the regular way. This track is perfect in strength, smoothness and durability. A year's experience with the Haydenville blocks on these business streets shows that the glazed upper surface wears too rapidly and their use has been entirely discontinued.

While this track, just described, was in every way a superior, durable and popular track, I gave further study to where additional improvements could be made in durability, strength and wearing qualities. My investigations and experiments caused me to decide on the following changes: 1st. To use a heavier rail with wider head. 2d. To substitute metal ties for wood. 3d. To secure greater rigidity and evenness in rail ends. 4th. A firm and permanent hold on the rails without the use of nuts and bolts. 5th. In paving, a better brick and of such shape as would provide a better flange room and contact with the web of the rail.

These changes brought us to an all steel T rail track.

#### RAIL.

When the Illinois Steel Company brought out the 72-pound shanghai T rail, which was an improvement both in weight, strength and in the width of the head of the rail over 60 shanghai T of same make, it was immediately adopted as the company's standard and was used in our latest and best T rail track construction. The shanghai rails of this company's make are so well known that a description is hardly necessary, but as this paper will be read by some who have not seen sections of them, I will give the dimensions of the 72-pound rail. The rail is 6 inches high; the base is 5 inches wide; the top, or head, is  $2\frac{3}{4}$  inches in width; the web from where the turns begin is  $3\frac{1}{2}$  inches. The long web permits the rail to rest on the ties and brings the top of rail to proper level for paving with brick, asphalt or granite blocks. In this track the rails are laid broken jointed. The 72-pound rail has a wider head, which gives better contact and wider bearing surface for the wheels of the car and even wear for the tread of the wheels. The edges of the wheels do not nick or chip out, as with the lighter rails with narrower heads.

Experience with the narrow head rails demonstrates that by wear an outer flange is formed on the wheel, and that this outer flange is very

destructive to the life of special work and the wheels. The wider rail head is also better for gravel or macadamized streets, as it gives no opportunity for the stones lying adjacent to the rail to nick the outer edge of the tread of the wheel.

#### FOUNDATION.

The foundation of a track is to a larger degree than any other part responsible for its wearing qualities, and this fact has not been lost sight of in our work. Good rails, ties, and joints cannot alone make a track, or properly sustain it so as to keep it level and give good wearing qualities, therefore, under all steel track it was determined to place a heavy foundation of the best material. After the necessary excavations, the ground was rolled with a heavy fourteen ton steam road roller. Then eight inches of broken stone concrete was placed in position and allowed to set. Then the rails, ties and joints were distributed, and connected together, and when the track is completed it is brought to the required grade or level by putting blocks under the rails at intervals, to bring track to proper grade. Then four inches of broken stone concrete is tamped under the ties and under the rails. After the tamping process is completed, the inequalities of the surface are filled with concrete, and the whole leveled up with concrete over the top of the ties, and pounded to a level surface with a wooden pounder, and allowed to set.

#### TIES.

The ties are steel, double corrugated, and heavily coated with tar while hot and being made, and are 2 inches high, 7 inches wide and 7 feet long, for straight line work, and were laid 15 inches between centers. For special work the ties vary in length as the necessities require, up to 20 feet or more. The metal of the tie is  $\frac{1}{2}$ -inch thick. These ties were manufactured by the Daniels Steel Tie Company, of Youngstown, O. The rails rest on and are fastened to the ties by clamps, with off sets to fit the base of rail. These clamps are secured and adjusted on the top of the tie by a special made bolt with oval shoulder, which is inserted from bottom of tie, with the head below and the nut on top, which permits a powerful box wrench being used to draw the nuts on bolts to a permanent position.

In using these steel ties in connection with the Wheeler rail joint, a mechanical difficulty arose, but which I overcame in the following way, after some study. The Wheeler joint has a thickness of three inches below the rail base, and in laying track with broken rail joints a straight tie would not answer. At first I thought it would be necessary to use a wooden tie under rail joints, but by devising a special tie was able to have them all of metal. The special steel tie for use under

and nuts and embodied the best of all mechanical principles—that of the wedge. These joints, at that time, had not been made for shanghai rails or for steel ties, but I overcame those difficulties by designing a new joint to be used with these rails and ties, and secured in this new pattern more bearing surface on the tie, by having the bottom of the joint made to fit the corrugations of the tie. The joint consists of two parts, one of which is keyed onto the other. The larger or heavier part, used on outside of rail, has two lugs that fit in the angle joint holes nearest the ends of rails. After it is placed in position the lighter part is keyed on with a large maul and holds the rails rigid. Then the tie is placed under joint and is fastened to it in the regular way, with the exception that the

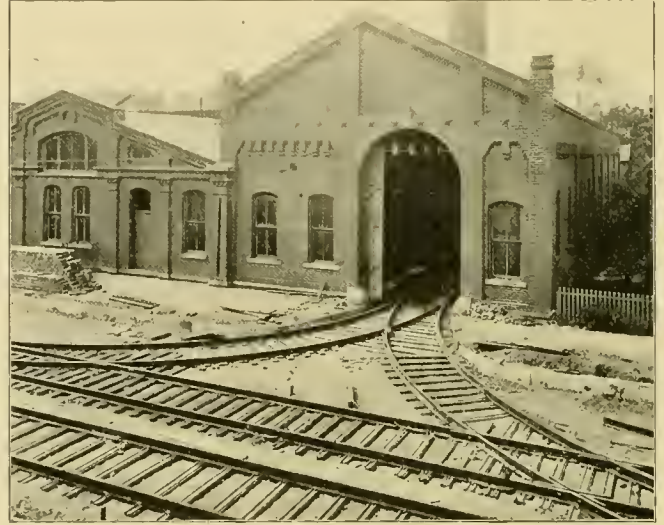

Y CURVES TO POWER HOUSE.

clamps have longer off sets; the holes in the ties for the bolts are also wider apart, on account of the width of the base of the joint. The joint has corrugations on each side at right angles to the rail, which gives it great strength. The joint is made of the best malleable iron, and weighs thirty-two pounds complete.

#### BOND AND SUPPLEMENTARY WIRE.

Iron wire having proved unserviceable and unsatisfactory, the heaviest copper wire was used in connection with this steel track. Double bonds of No. 0000 copper wire were used at each rail joint, one in the upper and one in the lower part of the web of rail; these bonds were soldered and connected to the No. 00 tinned copper supplementary wire that has been accepted as standard.

#### PAVING.

When the foundation is completed and the track set in it as just described, nothing remains but the paving to complete the track and street for use. The all steel track was laid on Ninth street, a business street leading from Wabash avenue, or Main street, to the Union depot and brick was therefore selected for the paving material. This brick pavement was laid as previously described, and needs no further description.

As the use of the Haydenville block had been abandoned and the angle nose cut brick did not touch the web of the rail, I designed a special shape brick that has many advantages, combined with the same wearing qualities as the brick on each side of the tracks. A sample pattern of brick which I have with me will give a clear understanding as to the shape.

#### DRAINAGE.

In the earlier laid track in paved streets, rapid and proper drainage of the tracks was not provided for. The paving was crowned to the center of the track and followed the slope of the streets, but when the lowest point in the street was reached, no provision was made to carry the water quickly to the sewer. In this new track, proper provision is made to get rid of the water from rain, snow and street sprinkling, quickly and effectively. In the center of each track, at the lowest point in the grade of each street, an 8-inch sewer pipe was laid to the sewer. Over the top or opening of this pipe, in the center of street, is placed a small catch basin, surmounted by a special made iron grating. The water flowing down the track and along the side of the rails is thus rapidly removed and a simple and effective drainage secured.

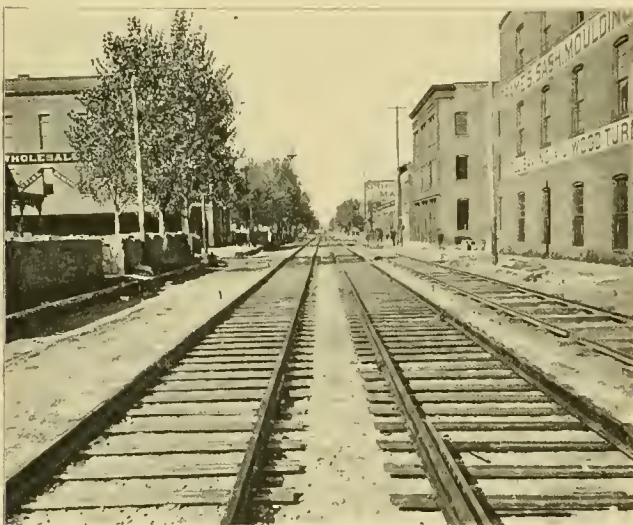

All Steel Track, Terre Haute. Fourth Process.—Track Ready for Tamping with Last Broken Stone.

joints was adjusted to the necessary levels by bending it down in the center three inches, by an easy off set.

In laying the track, these special ties were easily placed in position, and gave perfect satisfaction. The clamps and bolts were the same as on straight line work.

#### JOINTS.

I gave a great deal of attention to the subject of securing a good joint for this all steel track, and after examining many devices selected the Wheeler rail joint, made at Marion, Ind., as it did away with the bolts



## INJURY TO TRACK BY VEHICLES AND HEAVY TEAMING.

On our track, which is standard gage, 4 feet 8½ inches wide, heavily loaded vehicles cannot drive along it and get the benefit of the smooth metallic surface, as in the case with girder rails. This condition is a great improvement and makes a saving in many ways.

First. It saves an immense amount of money in repairing the injury and wrenching to track and rapid wear and tear thereto, caused by vehicles and particularly heavily loaded wagons turning in and out and driving along the track.

Second. It permits a quicker and more frequent car service, which all street railway men know means time and money, by giving the cars a clear track.

These are great advantages and will be best appreciated by the managers of the lines in the larger cities. They can also bear testimony to the large savings effected in the wear and tear.

To further prevent heavy teaming along the flange spaces of our track and at the same time make the wear and tear on the street paving, which we are required to maintain a minimum, the following ordinance was passed by our city council, October 4, 1892:

"An ordinance regulating heavy hauling over and through the improved streets of the city of Terre Haute.

Be it ordained by the common council of the city of Terre Haute, that it shall be unlawful for any person to drive, or cause to be driven, or permit his or her servant to drive upon any street or alley paved with wood, stone, brick or asphalt, any wagon or other vehicle having upon it a weight, which, together with the weight of the wagon or vehicle, shall exceed four thousand pounds (4,000) and less than seven thousand pounds (7,000), unless the tires upon such wagon or vehicle shall be at least three inches in width; nor shall any such wagon or vehicle having upon it a weight, which, together with the weight of the wagon or vehicle, shall exceed seven thousand pounds (7,000), be so driven in or upon any such paved street or alley, unless the tires on such wagon or vehicle shall be at least three and one-half inches (3½) in width.

Section 2. Any person who shall violate any of the provisions of this ordinance, shall, upon conviction therefor, be fined, and forfeit and pay not less than five dollars (\$5.00), nor more than fifty dollars (\$50.00), for each and every offense.

Section 3. This ordinance shall take effect and be in full force and effect on and after December 1, 1892.

Adopted October 4, 1892.

I, Chas. H. Goodwin, clerk of the city of Terre Haute, Indiana, hereby certify the above and foregoing to be a true and correct copy of "An ordinance regulating heavy hauling over and through the improved streets of the city of Terre Haute," as the same appears of record and on file in my office. Witness my hand and seal this 15th day of October, 1894.

CHAS. H. GOODWIN,  
City Clerk.

In closing this report, gentlemen, I wish to thank you for your attention, and at the same time express the hope that it will prove, as it was intended, a good guide to you in securing that very necessary condition for successful and economical operation—a perfect track.

Before closing I wish to call your attention to the fact that through the kindness of the Paige Iron Works, of Chicago, I am enabled to show you in the Exhibition Hall a sample of our special track work made of 72-pound shanghai steel rail and laid on the Daniels steel ties as we lay it.

Also samples of Wheeler rail joints attached and unattached to rails. Also a crude sample of our brick paving. This sample is not as correctly or as smoothly laid as we lay it in Terre Haute, but as I did not reach Atlanta in time to supervise the laying, it would be unreasonable to expect unskilled hands without guidance to lay it as our experienced employes do.

To the samples and photographs I have with me, and to the special track work and samples in Exhibition Hall, I invite the attention of all who are interested in the subject of perfect Electric Street Railway T Rail Track Construction.

Mr. Seeley desired to know difference in cost of construction between T rail and the same weight of girder rail, but Mr. Harrison could not answer the question, as he had had no experience in laying girder rail. He also said brick paving was more lasting than granite. There is no jolt or jar when cars go over the joints, which are made as close and tight as possible, with the usual space

for expansion and contraction. There is very little metal exposed, so there is not so much expansion or contraction as with a girder rail. The ties and rails are both tamped with concrete resting on a solid bed and there is a minimum wear and tear.

Telegrams were read from Thomas Lowry and the Commercial Clubs of Minneapolis and St. Paul, inviting the next convention to be held in Minneapolis.

O. T. Crosby sent a letter of apology for his inability to serve as chairman of the committee on standards and nomenclature. The committee was continued, consisting of Charles W. Wason, electrical engineer, Cleveland Electric Railway Company, Cleveland; L. H. McIntire, Philadelphia Traction Company; Thomas H. McLean, general manager Citizens' Street Railway Company, Indianapolis; C. G. Goodrich, vice-president and secretary of Twin City Rapid Transit Company, Minneapolis, Minn.

A letter was read from M. O'Connell, president of the Surface Railway Employes' Association of the United States and Canada, in which he expressed his desire to have more cordial relations between the official bodies of both employes and employers. The secretary was instructed to answer the communication.

The following was received from M. K. Bowen, superintendent of the Chicago City Railway Company and referred to a committee to be appointed by the president.

GENTLEMEN: I desire to call your attention to a matter, and not being able to be present with you at Atlanta this year, I have asked Mr. Penington to take up the same with you.

In the lines following you will find an outline of the subject referred to:

The list of patented articles in use on street railways is growing very fast, and has increased wonderfully since the adoption of electricity as a motive power. All street railways are paying either directly to the patentee, or indirectly to the manufacturer, a royalty on one or more devices in use in the operation of their lines. In many cases the patent is worthless, yet no test or investigation has been made to determine whether a royalty is rightfully due the holder of the patent or not, and consequently many thousands of dollars are spent annually in royalties that could be otherwise saved, or the price of such articles reduced by concerted action in fighting and exposing all such so called "patents."

The street railway companies are also liable to be made defendants in suits from using articles that are an infringement on some patent, while the manufacturer is the party that should stand the burden of such litigation and not the purchaser or consumer.

In this matter we are far behind the steam railroads of this country. In this city there is an organization known as the Western Railroad Association, that has been in successful operation for twenty-four years, and has a membership of ninety. There is also an eastern association, with headquarters at Washington, similar to the one here, and the two organizations have as members all the important railways in the United States, and most of the smaller ones. The several railways pay annual dues, based either on their mileage or gross or net receipts. This association furnishes reports and opinions on all patent matters on request from its members, and defends all patent suits in which the railroads are made defendants. The railroad, as a rule, gets an opinion from the association before buying, making or using any patented device. An association of this character would be highly beneficial to our street railway companies. If this could be carried into active operation by an association of street railways, all patented articles in use on our lines could be investigated and reported on.

In conclusion I will say that if it meets your approval, I would recommend that a committee be appointed to take up this matter and submit a plan of organization, to report to the executive committee at their meeting in January.

The president appointed F. R. Greene, Chicago; John

W. McNamara, Albany; Charles W. Wason, Cleveland.

A letter from J. J. Sullivan, of the Electric Traction Company, Philadelphia, was read, in which he expressed his regrets for not being able to attend the convention.

The committee on insurance appointed at the private session Thursday, was asked for a report, but on account of being unable to see a gentleman who was out of the city, nothing had been done.

W. B. Brophy, representing the Cotton and Woolen M. & M. Insurance Company, Rubber Manufacturers Mutual Insurance Company, and the Industrial Mutual Insurance Company, addressed the meeting at the request of members. His companies insure power house and car barn risks with premiums of 1 per cent on brick power houses,  $1\frac{1}{4}$  per cent on frame,  $1\frac{1}{4}$  per cent car barns brick,  $1\frac{1}{2}$  per cent frame, including contents. The limit is \$60,000. A dividend of 40 per cent was returned to policy holders. No restrictions are made in regard to cement or iron floors for power houses, but there must be no storage rooms without sprinkler equipment.

The amendments to the constitution and by-laws as recommended in the Executive Committee report were adopted.

Lewis Perrine offered the following, which was adopted:

RESOLVED, That the Executive Committee is hereby requested to take under consideration the question of the enlargement of the field and scope of the association and submit a plan suggesting ways and means therefor at the next meeting of the association.

#### ELECTION OF OFFICERS.

The nominating committee reported Montreal as the place of meeting, and for officers: Joel Hurt, Atlanta, president; W. Worth Bean, St. Joseph, Mich., first vice-president; John M. Cunningham, Boston, second vice-president; R. B. Harrison, Terre Haute, Ind., third vice-president; W. J. Richardson, Brooklyn, secretary and treasurer; executive committee, H. C. Payne, Milwaukee; General W. H. Jackson, Nashville; G. C. Cunningham, Canada; D. G. Hamilton, St. Louis and Chicago; John M. Partridge, New York.

The report of the committee was adopted as far as election of officers was concerned, but objections were made to Montreal as a place of meeting. Philadelphia, Cincinnati and St. Louis put forth their claims. The ballot resulted in the choice of Montreal, which received 38 votes to 17 for Philadelphia.

Granville C. Cunningham, manager of the Montreal Street Railway Company, said he was very much pleased that Montreal had been chosen by the association for the next place of meeting. He could assure the members that everything possible would be done to remove the difficulties in the way of bringing in supplies, and could, confidently promise that there would be no more difficulty in bringing supplies to Montreal than to any part of the United States.

The president appointed as a committee to investigate

mutual insurance, Messrs. Harrison, Terre Haute; Dyer, Augusta; Perrine, Trenton; Lusher, Montreal, and Baumhoff, St. Louis.

The paper on Transfers and Street Railways, by J. N. Beckley, was read by title and ordered printed. It will be found elsewhere.

The paper by Richard McCulloch, St. Louis, on Mail, Express and Freight Service for Electric Roads, which appears on page 626, was read by title and ordered printed.

James Vail read a paper on the Booster System, which will be found on page 607.

President Joel Hurt was escorted to the platform by Messrs. Dunlop and McNamara. He said:

"GENTLEMEN: I sincerely thank you for the honor you have conferred upon me. It was not sought, but I appreciate it none the less. I will not tax your time, but will simply say that I am fully in accord with those who have the best interests of the association at heart and have done so much to make it a success. I will do my best for the advancement of the association and ask your co-operation and help in every direction. I feel that the association is entering on a much more useful period than has marked its past career. Its scope should be enlarged to embrace features that are daily devolving on managers of street railways and should receive special attention from the association during the next twelve months."

On motion of Mr. Perrine, a vote of thanks was given the citizens of Atlanta in general, the Atlanta Consolidated Railway Company, the Capital City Club and other organizations, the local committee, local press and others for the many pleasant entertainments.

The following papers were read by title, as printed copies had been furnished to the members: Destructive Arcing of 500-Volt Fuses, W. E. Harrington; Brake Shoes, D. F. Henry and Powell Evans; Power vs. Hand Brakes, by E. J. Wessels, with a discussion by Elmer Sperry, which was delivered only to a committee, and will appear in the official proceedings, and Taxation, by Allen R. Foote.

The convention adjourned.

#### THE BARBECUE.

Partridges a-callin',  
Hick'ry nuts a-fallin',  
Country jest a-smilin' all around;  
Cattle bells a-tinklin',  
Silver frost a-sprinklin'  
Spicy-like, and sweetenin' all the ground!

By day, the sunshine streamin',  
By night, the sweetest dreamin'—  
Country jest as happy as can be!  
Not a bit o' trouble—  
Single-file an' double,  
The juicy joy jest rains on you an' me!

—Atlanta Constitution.

It was just such a day, on Friday, the 19th, when, at two o'clock, the barbecue was served at Ponce de Leon, a resort in the city of Atlanta, where there are woods and boats and bathing places, and bowling alleys, which in the North would be called picnic grounds. It was a

delightful walk of about 500 feet from the street car line to the long barbecue tables, of Georgia pine, on which were placed the wooden dishes with Brunswick stew.

But the beer came first. Many kegs, with long wooden spigots, were sweating from the cool amber fluid, brewed in Atlanta, which is superior to the northern beer. Each keg supported a huge piece of ice, and as they stood at the entrance to the grounds, were very inviting to the thirsty visitors, who enjoyed the cool refreshment of the long drinks.

The barbecue consisted of twenty-five carcasses, of pig, lamb, and kid. On Thursday, a trench 20 feet long, 3½ feet wide, and 18 inches deep was dug, hickory boughs were put in and set on fire at midnight. Other fires were started near by. When the wood had burned to ashes, which took about three hours, live coals from the other fires were put in the trench. Each carcass was laid on two hickory poles, or two iron rods, and was placed over the trench, being cooked by the heat from the wood coals, which were being constantly replenished. The cooking meat is basted for four hours by a long stick with a swab on the end, from a mixture of hot water, salt, pure apple vinegar, red pod and cayenne pepper, mustard, lemons, onions, a little garlic, and lastly is covered with the best dairy butter. The choice bits are first the kidney and next the ribs.

No barbecue is complete without Brunswick stew. Now, very few people can make Brunswick stew, as it requires a peculiar skill. The stew served at the barbecue required sixty chickens, which were chopped to pieces and boiled until all the meat dropped from the bones. Cow's liver was added, which had been boiled until it crumbled. Maine corn, which was sweet and tender, lemons, onions, Worcestershire sauce, and the same ingredients as were used in the basting of the meats, were boiled down with the liquor from the meats, until it made a most delightful, though very rich and palatable food. This stew had been boiling since 5:30 in the morning.

The barbecue will never be forgotten by those who partook of the real Georgia barbecue, for it was entirely new to them.

#### FRIDAY EVENING

the visitors packed their trunks, and left the fair city of Atlanta, at eleven o'clock, with many regrets that their visit could not be continued. Many pleasant acquaintances were formed, both among the visitors themselves and the citizens of Atlanta. The local entertainment committee was tireless in its efforts to impress upon all the fact that southern hospitality was not simply a name.

At 11 o'clock the visitors left for Chattanooga to be the guests of the Chattanooga Electric Railway Company, which had invited them to spend Saturday at Look-out Mountain and Missionary Ridge. Before the train left everybody assembled on the depot platform, singing the familiar songs that are customary, and as "all aboard" was shouted, gave three cheers for Atlanta.

#### PRESIDENT JOEL HURT.

Joel Hurt is an example of what can be done by a person who develops the opportunities that are around him. He was born in Russell County, Alabama, at the age of fifteen, being thrust upon the world without home, or support. Many a boy would have been discouraged at the outlook, which must have caused him to realize how helpless he was. That he had grit is shown by his career. He worked his way through academy and college, graduating in 1871 as a civil engineer.

For ten years he practiced his profession, being chiefly engaged in railroad work in the South. The lessons he

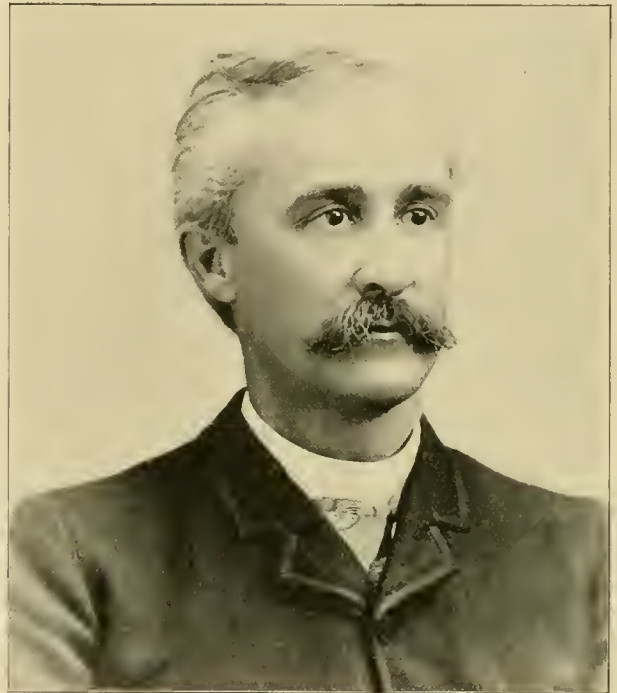

PRESIDENT JOEL HURT.

had been forced to learn in his youth were a good preparation, and the foundation for his prosperity was laid. Since 1881, Mr. Hurt has been interested in real estate and financial institutions in Atlanta, and is one of the foremost public spirited citizens of that beautiful Southern city.

He is president of the Atlanta Consolidated system, and stands in the first rank of street railway presidents. In 1892 Mr. Hurt was elected second vice president of the American Street Railway Association. His counsel and advice has always been sought by the officers.

Socially Mr. Hurt makes himself liked by all with whom he comes in contact. He was very active at Atlanta in his efforts to compel the visitors to enjoy themselves, the compulsion being caused by the many entertainments that were offered. Mr. Hurt is a pleasant speaker and his address, when he thanked the convention for the honor conferred upon him, reveals his modest character.



## EXHIBITS AT CONVENTION

THE Pullman Company was represented by W. S. Louttit, an old timer at railway conventions.

A. L. REGISTER, of Pepper & Register, Philadelphia, electrical and mechanical engineers, was present.

FREDERICK R. CASE, of Philadelphia, represented the Hoopes & Townsend Company, manufacturers of bolts, nuts and rivets.

T. H. MARTIN, managing editor of "Dixie," that leader of Southern industrial interests, was a most welcome caller at the REVIEW booth.

F. G. Fuller, special agent of Day's Kerite, took pleasure in giving information to the few who had never heard of that well known high grade insulation.

THE H. Falk Manufacturing Company, Milwaukee, through A. Hoffman, showed its patent trolley and method of casting rails together making no joints.

J. W. ENO, of the Wilkesbarre Traction Company, a sprightly young man of 75 years was the oldest delegate in attendance, but expressed his willingness to learn.

FRANK X. CICOTT, the genial story-teller and manager of the railway department of Pettingell Andrews Company, Boston and New York, was on hand, meeting old friends from all parts of the country.

THE Charles Munson Belting Company, Chicago, showed samples of various styles of belting for street railway work. H. E. Skinner had charge of the exhibit, which was an attractive one.

THE Wallace Electric Company, Chicago, was at Atlanta, in the person of Max A. Berg, secretary. He showed samples of Robinson's patent trolley wheel, Fletcher's rapid transit switch, Paulsen's rail bond cap, and printed matter.

THE Guarantors Liability Indemnity Company, of Pennsylvania, was represented by R. E. Watson, of Aaron Haas & R. E. Watson, general southern agents. Mr. Watson had a tastefully arranged booth, and gave away pocket books.

THE National Lock Washer Company, Newark, N. J., showed track joints with its washer locking nuts on bolts, of which 90,000,000 are in use by various truck and motor manufacturers and car builders. R. L. Thomas was the representative.

THE American Railway Supply Company, New York, showed buttons, checks, caps and other specialties, which are in wide use by street railway companies. Walter Chur, the general manager, distributed an aluminum pocket medal, representing Pikes Peak.

THE Niles Tool Works, Hamilton, O., showed a hydraulic press of 100 tons capacity, built especially for street railway work; a 36-inch car wheel borer. A 24-inch lathe was exhibited, which is sold to a great many street railways. W. A. Stadelman was in charge.

THE Flood & Conklin Company, Newark, N. J., manufacturers of varnishes, was represented by H. C. Dick, who demonstrated the value of the company's varnishes. He distributed stamp boxes, which were greatly sought, and an atlas. The Flood & Conklin Company is having a large trade.

THE Maxwood Brake Shoe Company, of La Crosse, Wis., had something new in the shape of specially prepared and hydraulically pressed wood for brake shoes. A pressure of 3,000 pounds per square inch does the business. A sample shown had been in service 10,000 miles making 1,836 stops.

THE Bushnell Manufacturing Company, Easton, Pa., had an exhibit of longitudinal and reversible seatings in plush, rattan, carpet and leather, with a new reversible cross seat for open or closed cars, reversing within itself. E. M. Bushnell, secretary and treasurer, was in charge of the company's interests.

THE National Malleable Castings Company, Chicago, Cleveland, Indianapolis and Toledo, was represented by F. R. Angell, sales agent. Overhead trolley material, rail braces, rail chairs and other supplies were on exhibition. The company does a large business in furnishing castings for street railway construction.

CHARLES L. CORNELL, Hamilton, O., showed two novelties, an electric soldering iron and an arc headlight. The soldering iron has been used in laboratory and shop work two years. The lamp works in series with the incandescent lights on the car. Twenty are in use on the Hamilton & Lindenwald Railway Company, Hamilton, O.

THE Adams & Westlake Company, Chicago, showed the Acme automatic car window shade, headlights, platform safety gates and curtain material and other specialties, under the direction of L. A. Gray and G. A.

Crisson. The special feature was a new automatic double locking safety platform gate, very simple and compact.

THE Stanwood Manufacturing Company, was represented by President Stanwood, always a welcome addition to any gathering of railway men. His steel steps were in service on exhibition cars, and while failing to remove any snow or ice from the feet of passengers, afforded a sure and firm footing which alone is a sufficient recommendation.

THE Fitzgerald-Van Dorn Company, Lincoln, Neb., represented by W. T. Van Dorn, exhibited its automatic draw bar for street railroads and the type of automatic drawbar, to be used by the Metropolitan Elevated Road, Chicago. There was also a ball and socket joint attachment for the drawbar to take up lost motion, and a bar for going up and down mountain roads.

THE Stilwell-Bierce & Smith-Vaile Company, Dayton, O., Chicago, New York and Atlanta, exhibited steam pumps, Victor water wheels, Worrall friction clutch, railway truck jacks, steam feed, water heaters, purifiers and a self-oiling device for loose pulleys in connection with a friction clutch. J. W. Taylor, Southern agent, Atlanta, and E. J. Whitehead, city agent, prepared the exhibit.

THE Bass Foundry Company, Fort Wayne, occupied a conspicuous space in the center of Machinery Hall, where the artistic taste of P. F. Leach was evidenced in the arrangement of the exhibit, which included both cast, steel tired and cushion street car wheels. Samples were also shown having been in long and specially severe service, and altogether the display was fully up to the high standard of the Bass Company in former years.

E. F. DEWITT & Co., Lansingburg, N. Y., showed a new pattern of the common sense sand box. E. F. De Witt, who was at Atlanta himself, said that the new box can be put on old cars, and be worked where there is three inches of room. The knives are further up in car and the sand is in the car. Three regulators are fitted to the box so that it is adapted to any kind of sand. These sand boxes were used on the Jackson-Sharp exhibit cars.

THE Central Electric Heating Company, represented by Edward B. Wyman, general manager, R. J. Jerome and Sydney Hoch showed three styles of car heaters, A, B and C, in operation, using a special wire of its own, which has high resistance. The company has closed a contract to supply all the electric cars of the North Chicago Street Railroad Company with its heaters, which are used by 200 roads, either under the riser, against the riser, or under cross seats.

THE Davis Car Shade Company, Portland, Me., showed various styles of shades. The Inside, an oval tube, are two rods, which press a brake against a rubber wheel, preventing the shade from moving. The wheels

revolve in a groove, when the brake is released, and it is said there is no staggering. A waterproof curtain for open cars was exhibited, having the same attachment. C. M. Fuller, the general agent, says the curtain can be rolled up wet and left six months without mildew forming.

THE Rochester Car Wheel Works, Rochester, N. Y., showed fourteen wheels from 700-pound locomotive wheels to 200-pound street car wheels. A 33-inch motor wheel, originally 300 pounds, in use for two years on the Rochester Railway, having traveled 70,000 miles, was an interesting specimen. It weighed 240 pounds, having lost 60 pounds of metal and  $1\frac{1}{8}$  inches of its diameter. F. D. Russell, general manager, and George C. Morse, general sales agent, represented the company.

THE Michigan Electric Company attended its first convention with a large assortment of overhead material, attractively displayed. A new feature in signal lights was shown for the first time, consisting of an incandescent lamp in a lantern, behind a semaphore lens, the whole attached to the side of the revolving portion of trolley stand. Thus an approaching car distinctly indicates its route by color. The signal has been tested satisfactorily for eighteen months. Exhibits in charge of Joseph E. Lockwood.

THE Scarritt Car Seat Company, St. Louis, showed four styles of patent reversible seats, covered with cane, plush, imitation leather. These seats have a superelastic cushion. One plush and one cane longitudinal seat were shown. There were samples of the Columbian hand strap, with advertising features. S. G. Scarritt, manager, St. Louis, and H. O. Nourse, Chicago, were the representatives, and distributed a puzzle called "Coons in a hole," consisting of a small box covered with glass, four shot, one of which was to be put in each of four holes, a difficult yet attractive task.

THE Taylor Electrical Truck Company, Troy, N. Y., was represented by John Taylor. Mr. Taylor, showed the Taylor improved single truck, and the empire state radial truck, with Eureka anti-heating metal lined bearings. The empire truck is said to be safe to run 40 miles an hour, and curve around a 34 foot radius. The weight of motors is carried on the driving wheels. The form of truss in frame, has been changed. A new compound lever brake is furnished with the trucks which can be used with absolute safety, Mr. Taylor says, on a  $13\frac{1}{2}$  or 14 per cent grade.

THE Composite Brake Shoe Company, Boston, Mass., had an exhibit in charge of Geo. C. Ewing, superintendent. One shoe, and two that were worn out, were shown. A McGuire's truck was expected, but final arrangements were not made. The company has a record of 20,000 miles in 8 months, of one of its shoes on the line of the Trenton Passenger Railway Company, Tren-

ton N. J. The favor with which the composite brake shoe has met, is shown by the rapid growth of its trade. A year ago, only one foundry was necessary, but now four are in steady operation in Boston, Philadelphia, Pittsburg and San Francisco.

THE Meaker Manufacturing Company, Chicago, with extensive works at South Waukegan, Ill., was at Atlanta, in the person of J. W. Meaker, the president. Four stationary fare registers and several portable registers were shown. The stationary registers have a new mechanical pull, which is an improvement over the old method. A new mechanical trolley wire clip was shown, which has only two parts, wedging very tightly. Mr. Meaker showed a new hanger with a taper bolt of new insulating material. It can also be used with the Aetna bolt. Both the clip and hanger attracted a great deal of attention, and were probably the most important of the new devices shown.

THE E. T. Burrows Company, Portland, Me., represented by John W. Baker, showed models of five different kinds of shades. The oakette, for open and closed cars, is the exclusive property of this company. It is absolutely impervious to water, is durable, and can be cleaned. Mr. Baker says it rolls smoother and smaller than any other shade, not taking as large a space as cloth, and will last two or three times as long. It is different from any other shade material, not being affected by cold or heat. One hundred and fifty samples of goods entirely new and exclusive, were shown. The fixtures are more attractive and are proof against rust, preventing metal from rotting out the material.

THE Fulton Truck and Foundry Company, Mansfield, O., had a well arranged exhibit which was crowded all the time. W. E. Haycox, president and general manager, and Frank A. Rogers, special sales agent, were in charge. The imperial single steel truck, with improved life guard, brake rigging, with springs over journal box under the truss, was set up on the floor. In operation was an imperial double truck run by a Card motor. The equipment of the double truck is the same as the single, except it has a special swing brake. There was also shown the improved track cleaner, which will pass over any large obstruction such as stone, and immediately return in position. A six-inch hydraulic motor was exhibited.

THE Mather Electric Company, Manchester, Conn., had no exhibit except a desk, printed matter, showing its multipolar generator, direct connected generator, Ring type dynamos, Manchester stationary motor, photographs of the multipolar generator. Thomas C. Perkins, vice-president and J. Holt Gates, western contractor, Chicago, entertained. It was the intention to show a 100 kilowatt new type multipolar machine and some Manchester type motors. One multipolar machine was built for the convention, but was sold before it could be shipped, to the Street Railway Company at Danbury, Conn.

Another was built to take its place, but was sold to go to Scranton, Pa. The shops are worked until 10 p. m. every night.

THE Baltimore Car Wheel Company, Baltimore, Md., showed the Lord Baltimore truck, equipped with No. 12 Westinghouse motors, also a Lord Baltimore truck equipped with Baltimore central suspension and General Electric 800 motors. The Baltimore central suspension supports the motor under the center of armature taking most of the weight of the bearings, adding to the life of the bearings. Two bearings were shown that had been in use two months, the only signs of wear being two marks. J. B. Scott, mechanical engineer of the City & Suburban Railway Company, Baltimore, writes: "After two months' use there was almost no wear at all. It facilitates the removal of armatures and lessens the cost of track repairs." J. Paul Baker, secretary of the company, was in charge of the exhibit.

THE Consolidated Car Heating Company, Albany, N. Y., and Chicago, was represented by James F. McElroy, consulting engineer, Edwin A. Smith, general agent, Chicago, and H. R. Ransom, special eastern agent. Five different styles of electric heaters were shown in operation on car seats, three of which have only the opening of the heater in the riser, exposed in the car, and represent different styles of finishing. The casing is made of iron, lined with asbestos. Two styles were shown for use where objection is made to cutting the panel, the heater being screwed against the riser on the outside. The wire is wound around flat porcelain in some styles, and around tubular porcelain in others. An ornament shield protects the resistance material, and at the same time permits at all times a free flow of air. Where the seats are placed crosswise, a short heater with iron casing is attached under the seat. An improved regulating switch regulating the amount of current used in the heater, is so arranged, as to prevent sparking taking place. These are furnished with either wood or metal frames. Fuse boxes of new design, with snap lock switches, were also exhibited by which the switch is locked closed until the handle is clear back.

WHILE the Westinghouse Company did not have the usual elaborate exhibit in the exposition hall, for which that company has always been noted, there was, nevertheless, a good deal of Westinghouse apparatus displayed about the city. In the power house of the Consolidated Street Car Company, the three generators, two 400 horsepower and one 750 horse-power direct connected generator attracted a great deal of attention and a constant stream of visitors was noticed watching the operation of these machines. They were generally admired and praised for the substantial manner of their construction and the smoothness of operation. The Westinghouse Company had also a number of their new No. 12 motors and new style controller equipments on the cars running to and fro between the city and the exposition grounds.

(Continued on page 663.)

## POWER BRAKES VS. HAND BRAKES.

Paper Read at Atlanta Convention by E. J. Wessels, General Manager of the Gennett Air Brake Company, New York City.

Gentlemen: Hand brakes and friction brakes have not materially changed since the day they were first put in service. It is obvious that a brake only powerful enough to stop a small, slow moving light weight car, has outlived its usefulness when applied to cars weighing seven tons or more, propelled by an unseen force which has driven live stock from the field. The modern brake, when placed alongside of the old-time brake, bears the same relation to it that an arc light does to a kerosene lamp. Brakes of all kinds are useful, but the brake installed to day should answer all the severe requirements of modern practice.



E. J. WESSELS.

By common consent, the two things regarded as most important in steam railroading are the wheel flange and brake. None of us would like to travel on the Empire State Express if we had to depend upon hand brakes instead of the well known air brake. It is not strange that car builders have not kept pace with present requirements, in their braking apparatus. They have done well for the street railway fraternity, but heads and hands have been occupied in developing trucks, wheels and car bodies, and builders have not been able to do justice to the brake. The radical changes in car building brought about by cable and motor cars, have kept builders busy. They could not devote their entire attention to improved brakes. We have no controversy with car builders on this question and wish to suggest rather than criticise. If buyers demanded improved brakes, builders would conform. As such demand has not been made, the brake of to-day remains in appearance substantially what it was twenty years ago.

The evolution of the electric motor has been rapid and astonishing. Motor builders have had great odds to contend with, but have overcome them, and the leading types of machines combine efficiency with low cost and economy of operation. Motors have been standardized.

It will not be denied that hand brakes are inadequate. If power brakes could be furnished at the same first cost as hand brakes, they would be universally adopted. The day is approaching when air brakes will be considered as separate equipments and will not be quoted in the lump sum named per car. There is no more reason for including brakes in the estimates than for including motors. On roads free from grades, there is obviously not such imperative necessity for reliable brakes as there is on roads which have grades of from five to fourteen per cent, or where travel is congested, and especially on suburban roads operated at high speeds.

Railway men are seeking the most improved appliances of all kinds. They have found it profitable to include many things in their rolling stock which formerly were not used. Thus, elegant cars have come into use equipped with vestibules, plate glass, stained glass, Pintsch gas, upholstered seats, electric heaters, fine head lights, and even call bells. These are radical departures from the old time cheerless cars, which were generally not heated and had smoking oil lamps, and floors littered with straw. Improvements pay. If they did not, they would not be made. Formerly it was difficult to work one's way to the door of a car, and when one got there, it was at times hard to get out. To-day, with improved facilities for ingress and egress, crowds are comfortably carried. This change in car construction involves additional expense. It is paid without complaint, because the outlay is found to more than pay for itself in increased business. Then, too, the public demands improvements, and there is more disposition on managers' part to give the public what it demands, if practicable.

It will not be maintained that the improvements are absolute necessities, nor can it be shown that they are in any sense "life-saving." Ocean flyers in service have \$20,000 oil paintings ministering to the aesthetic taste of tourists, in their saloons. In the hour of collision it

is far more important that passengers have a properly constructed life-boat at their disposal, than any creation of the painter's art. Each has its sphere, but the more important thing is the life-boat. It is so in street railway practice. Cars should be artistic, but they should be equipped with brakes that will do their work quickly when danger impends.

On steam roads hand brakes proved utterly inadequate. They were tested and found wanting. When the first air brake made its appearance it encountered great opposition. Where would steam railway practice be to-day if air brakes were eliminated? The battle of power brakes vs. hand brakes on steam roads was fought years ago, and air brakes remained in possession of the field. It is questionable if the need for power brakes is as great on steam roads as it is on surface roads, especially when trailers are run. Steam road stations are miles apart. It was comparatively easy for an engineer to whistle "down brakes," to cut off steam and bring his train up standing. The inertia to be overcome was greater, but he had not the grades to contend with that exist on surface roads.

Electric cars, in even out of the way places, ascend grades that no mogul engine has to confront. Of course there is a corresponding down grade, and it is here that the difficulty arises, for surface cars ought to stop for passengers, no matter how steep the grade or high the speed may be. Otherwise earnings decrease. The braking power on an electric or cable car should be so positive as to permit of stopping in less than the car's length, if necessary. One has only to watch the men braking cars going down such grades as exist in Albany and Jamestown, N. Y., Easton and Allentown, Pa., and scores of places, to have a full appreciation of this point.

Recognizing the inadequacy of a single hand brake on grades, many roads have provided a duplicate inside equipment. This extra equipment is additionally expensive, not only in first cost, but especially in maintenance. A motorman realizes how difficult it is to keep his car under control, hence he sets one brake before car starts down grade. He then depends upon his other brake. Manifestly, when one brake is set from start to finish, it means wear and tear of apparatus and short life for the shoes. Moreover, the speed of car is needlessly retarded and fewer car miles per day can be run than would be made if he had a positive braking outfit at command.

In a good air brake the brake cylinder is constructed of iron and contains a piston and piston rod, which is attached to brake levers under the car. The rear end of the brake cylinder is made air tight, and connected with the train pipe, so that when air is applied from the reservoir it forces out the piston in the cylinder and sets the brakes. The power of the brake cylinder can be easily calculated, and is equal to the square inch area of the piston multiplied by the air pressure carried in the reservoir, hence:

Brake cylinder 6 in. diameter and 30 lbs. pressure gives 848 lbs. power at the brake cylinder.

Brake cylinder 7 in. diameter and 30 lbs. pressure gives 1,154 lbs. power at the brake cylinder.

Brake cylinder 7 in. diameter and 32 lbs. pressure gives 1,231 lbs. power at the brake cylinder.

Brake cylinder 8 in. diameter and 35 lbs. pressure gives 1,759 lbs. power at the brake cylinder.

This may be increased by using larger diameters, or higher pressure, and by arrangement of brake levers any additional power may be obtained; at the same time it can be graded suitably to the weight and speed of car.

Friction (or continuous) brakes operated from the axle have been used for years, and the jar from them has caused constant complaint. The braking force requisite to bring a car or train to a stop, should never exceed the weight of load resting upon the wheels to which brakes are applied. Any power applied in excess of this is wasteful and dangerous. The full power of a friction brake depends upon the load carried on axle to which friction discs are attached. With a grip car and passengers weighing 8,000 pounds, the weight being equally divided between two axles, leaves 4,000 pounds carried by the axle with friction discs. With a car wheel of two and one-half times the diameter of friction drum, we gain that much leverage, which multiplied by 4,000 pounds, gives the direct pull power of friction brake of 10,000 pounds.

Nor is this all. The brake levers of street cars are, as a rule, adjusted to about four and one-half times leverage. If, then, we multiply the 10,000 pounds pull of friction brake by this leverage we have a strain of 45,000 pounds upon brake beam and shoes. This is vastly more power than is ever required. When two or more cars are

coupled together it is impossible to regulate brake chains and brake gear so that every shoe will press with equal force against the wheel.

When, therefore, a gripman applies his friction brake, the entire 45,000 pounds is carried by the beam and shoe that are adjusted nearest the wheels and the remaining wheels revolve without noticeable check.

In a train of three four wheeled cars with passengers, weighing 36,000 pounds, resting on twelve wheels, a brake power of say 2,000 pounds applied to each wheel would make the most perfect stop. If the entire 45,000 pounds power of friction brake is applied to only two wheels of such train, there will be 38,000 pounds more power exerted than necessary to stop wheels from revolving, and at same time only one-sixth effectual braking power is obtained as compared with a braking pressure distributed against every wheel under the train. Such harsh, rigid excessive power of the friction brake, applied quickly by the momentum of the whole train, will wear out any kind of brake gear, no matter how good or how strongly made, and the constant jar adversely affects the life of cars. In cold, wet and stormy weather (with slippery tracks), when grip car is abandoned except by the gripman, the pull power of friction drum is greatly reduced just at the time it is most needed to set brakes on trailers which are always overcrowded at such time.

A twenty-eight foot closed electric car weighing without passengers 20,000 pounds and running at ten miles per hour, has over six times the energy to overcome when brakes are applied, that a horse car has, weighing one-fourth as much and traveling at less than one-half the speed. Moreover, when horses were employed there were ten feet extra length in which to stop car. This extra length is no longer available since the advent of electric cars. Unless cars have proper brakes, high speeds are most dangerous.

Without entering the humane feature of braking, it cannot be denied that at best hand braking is a great task for even strong men. They report fresh in the morning and for a time muscles stand the strain; but after a few hours handling of a grip lever or controller handle, they find their strength decreasing. Realizing this, for the rest of the day they slow up earlier than strictly necessary or (as often happens) they do not stop at all and let cars run past crossings, missing passengers, who do not always wait for the next car, but walk instead.

If, however, the men have ready for instant use an ally in the shape of power requiring but the touch of a handle to become available, they are placed in the best possible position to make as many stops in as short a distance as is necessary. Not being fagged out, they are better able to do their company more justice and are more on the alert to prevent accidents.

In the distressing accident which occurred seven weeks ago in New Jersey, this point was particularly emphasized. We quote from New York *Herald*, August 27, after having ascertained from the officials that the report is accurate. "When the crowded car began to go down the incline, the brakes would not respond promptly to the demand of Motorman Gornley. Tight as he could wind up the chain, he felt it slip repeatedly. He knew what this meant, and with full strength he set the brake as hard as he could. But his efforts were in vain, and the car gained greater headway every instant. It was beyond his control, and he realized that in a few seconds the car would strike the sharp 'Crab tree' curve. As it dashed down the steep mountain side tracks, he turned and shouted to Conductor Badgely to put on the rear brake chain.

"Badgely was inside the car, and at Gornley's call every one suddenly realized the danger. The conductor was wedged between the passengers but he fought his way to the rear platform and wound up the remaining chain of the single brake system from there. In an instant he saw that it, too, was of no use in the emergency, and turning, he shouted, 'Jump, for your lives? The car is running away and will strike a curve.' The car was rushing on to that fateful curve. Like a shot propelled by some awful power it went. Then it struck that curve. A section of one of the wheel flanges snapped off, and an instant later the car left the rails. It ploughed its way across the track with scarcely any perceptible diminution of speed, was jerked sharply to the right, when the wheels struck the opposite rail and then capsized, landing squarely on its side with a crash which was heard a quarter of a mile away."

We need not pursue the account further, except to say that eighteen people were hurt, many of them badly, and one boy's arm had to be amputated. A \$35,000 damage suit is pending against the Accident

Insurance Company which wrote the risk on that road, and the same company has settled a number of cases out of court.

It is only fair to state that had that entire system been equipped with power brakes equal to such emergency, the car could have been stopped long before danger point was reached, without injury to limb or property.

It is not the purpose of this paper to make capital from such sad occurrence; we are opposed to sensationalism, but it is proper to call attention to such calamity, as a warning. What happened on that road has happened on others, and will again occur, so long as implicit reliance is placed upon hand brakes, which cannot possibly do the work required of them at such crisis. The first cost of equipping the entire line with power brakes would have been but a fraction of what the damages will cost.

It is unnecessary to multiply instances where hand brakes have shown radical defects. That practical men have been apt to think too lightly of the question of improved brakes, is explainable by their having so many other important things to oversee. Then, too, the aim of a railway man is to incur as few obligations as possible, and to operate with utmost economy and earn dividends. But often seemingly cheap apparatus proves dearest in the end.

Probably 75 per cent of recorded accidents are chargeable to inefficient brakes. Statistics of this sort are hard to tabulate, and some records show even a higher percentage. While hand brakes often stop cars quickly, they do so by consuming excessive energy. This means waste and increases maintenance account. Then, too, it is impossible for a motorman to maintain his maximum strength for a long time. In active service he has to apply brakes between 250 and 400 times daily. He can only exert his maximum strength spasmodically and temporarily, even when aided by the weight of his body. "A chain is no stronger than its weakest link."

The day is past when railway employes are considered merely automatons. Not all men make good motormen or gripmen. These positions, like that of conductor, are ones of trust. The men, as a rule, are intelligent, and during the recent financial depression many recruits have been made who formerly filled much higher spheres. The strain of a day's work on these men is very severe. When we consider how many chances people take in crossing tracks in front of moving cars, or in jumping on or off despite printed warnings, this strain becomes more apparent. No matter how fast or slow cars go, people are always dodging them with reckless disregard of danger. A motorman is not allowed to shout. He is required to keep silent. In the presence of danger he can only rely upon his gong or whistle and his arms. These alone are not adequate when drunken or deaf men are on the tracks.

The most painful thing which comes under a street railway man's notice, is the killing or maiming, especially of children. When a little child, ignorant of danger, toddles to the track and sees the car coming, it generally stops, hesitates, starts off and usually rushes in front of the car. The motorman, who has to depend upon a hand brake at such time, seldom succeeds in stopping his car. It is not an unusual sight to see a little child taken from under the wheels.

Touching the legal aspect of the brake question, while it often happens that plaintiffs are non-suited on the ground of contributive negligence, to the railway man this frequently means outlay for legal talent. Even though his company or the underwriters are not called upon to pay damages in such cases, it is surely better to prevent accidents than to defend law suits, especially as prevention is cheaper.

It is a menace to life and property to have a high speed motor at work without having suitable power to control it. Thus far "reversing" has not proved a success, and, while theoretically one motor acts as a generator to drive the other (if there be two, which is not always the case), in practice this has proved a failure. The danger of relying upon the same current which propels a car to stop it too, is only too apparent. If the current fails to work in one case, how can it be expected to work in another? The trolley may run off, or there may be a break in the line when current is needed for braking a car plunging down grade. "It's the unexpected that happens."

Hand brakes have no emergency stops. Air brakes have, and, if necessary, stops can be made so quickly as to apply brake shoes instantly to every wheel on one car or a train of cars, in the most effectual manner. No hand brake can do this.

When hand brakes are used it is necessary to have a separate brakeman for each trailer. When an air brake is used, these extra men are entirely dispensed with. On a train of a motor car and two



trailers, if air brakes are used, only one motorman and one conductor are necessary. If hand brakes are used to control the same train, four men instead of two, are necessary. This means a saving in wages of at least \$25 a week, and will soon pay for an air brake equipment.

Moreover, when air brakes are used, there is no shuttle movement jerking or jumping, and the shoes are applied evenly to all the wheels; whereas, in hand braking it is impossible for different men on different cars to brake in harmony. One car will be braked hard and another not so hard. Of course no good results from such ununiform braking.

Air brakes are provided with reserve power stored in reservoirs, and, by having large enough capacity, the air pressure required for braking becomes practically inexhaustible. The air pump of a thoroughly good air brake is most economical in operation. It requires no power when car is starting or when it climbs grades. As it takes ten times the power to start a car that it takes to keep it going, the advantage of this is obvious. A good air brake is so compact that very little room is required for it under car body. It has no cumbersome or complicated machinery to get out of order. It works automatically. It needs much less attention than an electric motor gets. It is only necessary to keep the mechanism clean and in order, and to lubricate pump regularly. No binges or springs annoy inspectors or employes. A good air brake pump, the moment it has compressed sufficient air, cuts out and runs in free air with the axle. A good air brake entirely replaces a hand brake. The hand brake may be left on the car, and the air brake can be so attached as to leave the hand brake available should it be required. A good air brake requires no expert to operate it. It is so simple that a child can work it. This being so, a railway manager is not restricted to hiring men of a certain height or weight, for when work is done by compressed air instead of muscular strength, no Samson is required to work the handle.

In steam practice, trunk lines maintain schools of instruction in which men are taught to handle air brakes, and only qualified engineers are trusted to operate them. A good air brake for surface roads is so constructed that, when used by men not schooled in its use, it does not get out of order. It is capable of being misused without proving defective. The physical labor involved in working the ordinary hand brake causes the other good qualities of a gripman or motorman to suffer. This has a direct bearing on accident account, wear and tear and repair accounts. The application is obvious. "A stitch in time saves nine."

A good air brake enables a man to make the best possible stops without noise, jar or injury to apparatus. In hand braking much excess force is used. This means that rods and bars are strained when stopping car, and often brake gear is in such shape that, when a quick stop is required, some part is sure to collapse.

One type of air brake equipment in service enables a gripman with but a small handle to work grip and brake either simultaneously or independently. When this type brake is used on car, grip and brake levers are entirely removed, giving more space for passengers on platforms. Through its use, what formerly involved painfully hard work, is now accomplished with ease. This device is in successful operation on car 421 of the Third Avenue Railroad, New York.

We believe it is better to keep the motor controller and the brake handle separate, but if railway men demand a single handle to operate both it can be supplied just as was done in the air brake on Third Avenue, New York, car 421, which works grip and brake. We doubt, however, if real necessity for a single handle exists.

Recently a new form of power brake has been announced, in which electricity is relied upon. The electric brake, while undoubtedly possessing some valuable features, has some which are a decided disadvantage. It is, of course, in its infancy, and the future of the electric brake will be watched with interest. We saw the paper read by Mr. Sperry on the 19th of last September before the American Institute of Electrical Engineers, entitled, "The Electric Brake in Practice." Mr. Sperry, unknown to himself quotes our language verbatim, which was used as an editorial by one of the dailies and subsequently was copied in the journals. It is to be regretted that, when using a part of our matter, the able electrician did not use other parts also.

He says that a locomotive engineer has his pressure gauges, which allow him to adjust the brake application to a nicety. A good air brake for surface roads is also supplied with a pressure gauge, but in practice no Westinghouse air brake engineer looks at a gauge, and they are more ornamental than necessary. He states that with an electric brake the brake shoes are entirely dispensed with. Do the street railway men intend to abolish brake shoes? Suppose, as may happen, the electric brake fails to work, what will become of the car or train? There is an

apparent contradiction in the article on this point. In one place it states that the electric brake does away with brake shoes, and in another place it admits that it will be necessary to resort to hand brakes. How can hand brakes be used without shoes, and how can a car be held by an electric brake after the residual magnetism (or Foucault current) is dissipated? He says that the one grave fault of an air brake in railway service is that the maximum brake application does not exist as it should at the higher speeds. This is an error. The immense advantage of an air brake over an electric brake is the fact that power can be applied in varying degrees; great power when needed and almost imperceptible power if only very slight retardation is wanted.

An air brake holds the wheels and keeps doing so. An electric brake, after first stop, depends wholly upon residual magnetism. This, at its best, is an uncertain factor. As we understand the paper, the residual magnetism in the electric brake is only available for something less than one-half minute after car has stopped. When this magnetism is consumed the electric brake possesses no more braking power whatever, until the car is again in motion. It is right here that the air brake shows its immense superiority, for it has the air reservoirs to draw upon when a car is stopped, and therefore ample power is available for immediate and constant use. This failure in source of supply is a tremendously weak point in an electric brake. The paper states that "the current flowing after motion ceases, though small (mark this admission) is found exceedingly useful in holding the car from starting itself, even on quite a heavy grade, as only a small quantity of energy, added to the already great friction of quiescence, will prevent the car from starting." We fear that at such times the advocate of electric brakes would need something more reliable and constant to lean upon. The paper says, "when an electric brake is used it seems as though the car was running into an air cushion." This pays a well merited compliment to air brakes, for by them an air cushion stop is made possible. The paper adds "operating the brake in this manner it will at once be seen that the system is one of the utmost certainty of operation, surer even than the hand brake, air, or other power brakes." If the speaker had not been for some years in the electric motor business, he might not take such decided exception to this claim as he does; but since working with air pressures he has found them much more reliable and safer than electricity. The inventor referred to makes fourteen claims of the advantages of his brake over other brake systems. As this paper is not written for advertising effects we purposely refrain from naming any special make of air brake in contrast with the electric.

1st. He speaks of the certainty of an electric brake in operating.

So is a good air brake certain in operation.

2d. The enormous power and under perfect control.

A good air brake has much more power, more constant power, and is under better control. It will be noticed that the inventor omits all reference to electric brake power being constant. This lack of constant braking power is the objectionable and fatal defect of the electric brake. It will not be noticeable on a level, but it will be only too apparent on a grade. At the Institute meeting, before which the paper on electric brakes was read, one of the members stated he had been on a train in Connecticut where two motor cars and three trailers were ascending a nine per cent grade. While doing so a fuse on the second motor car blew out, throwing all the work on the first motor car. This it was unable to do and hand brake had to be immediately applied to prevent train from running away. The author of the paper was asked "what would you do at such a time with your electric brake?" Mr. Sperry, in reply to the question, said that a case of this kind was rather unusual, but that he would have applied the electric brakes, which would have brought the train to a stand-still, and by that time the hand brakes could be applied to prevent the car from running backward down the grade. How then can he claim that the brake dispenses with brake shoes, and if the electric brake had been used on the train in question to the exclusion of hand brakes and brake shoes; what would have become of the train and passengers?

3d. "The absence of all power absorption at moneyed cost from the central station."

This may be true if brake shoes are not used, but remains to be proved in daily service. Shoes probably will continue to be used. A good air brake consumes very little power. You can test how little by watching the readings on a car operated at this time with an air brake on the Atlantic Consolidated Road.

4th. "Its high efficiency, being far superior to compressed air; amply proven in numberless instances where electricity has replaced air. (The air requires a direct application of energy, amounting to an immense aggregate power absorption during the day from the central station; the working parts of the air machinery are attached to the car axles and re-

quire a large quantity of energy not only while compressing, but at other times as well."

We are unaware of a single case where electricity has replaced air. We are informed on high authority that air compressors for driving rock drills and coal cutters so greatly outnumbered electrical machinery for such purposes that hundreds of air compressors are sold for every drill or cutter sold. The statement that an air brake requires a large quantity of energy not only while compressing, but at other times as well, is wholly inaccurate and entirely incapable of proof. A good air pump requires no perceptible power after it cuts out."

5th. "Its extreme simplicity."

So is a good air brake very simple.

6th. "Observe saving in wheels, two or three fold."

A good air brake properly applied saves the wheels.

7th. "Saving of brake shoes."

We believe brake shoes will be retained and would not care to ride on a car without them. Under certain conditions the paper admits hand brakes will be needed. How can hand brakes be applied without shoes?

8th. "Very little wear of either wheel or magnet."

There is little wear to a good air brake, and lightning plays no pranks with an air brake, but is likely to do so with an electric brake.

9th. "No hissing to frighten horses on streets."

We have yet to hear of a case where a horse was frightened by an air brake.

10th. "The low E. M. F. at which it operates."

That is true of a good air brake. It is easy to test power consumption with a watt meter, by running car with air pump, and then running car (under exactly similar conditions) with air pump detached; the slight power consumed will then appear.

11th. "The ease of its application and control."

Nothing surpasses a good air brake in these respects.

12th. "Conserving strength, prolonging the usefulness and life of the motormen."

This is open to question when one sees the despair of motormen when fuses melt and switches burn out. Gripman Williams, on air brake car 421 of the Third avenue road, New York (where 120 equipments are in daily operation), told the speaker, "This job is so soft, I expect some of you Wall street fellows will come here to run cars since times are hard."

13th. "The smoothness of its operation."

Nothing can surpass the air cushioning effect of a good air brake.

14th. "Cannot cause flat wheels."

A good air brake properly applied also prevents flattening of wheels.

We had no intention to refer at length to electric brakes, but have felt constrained to do so because the statements we have replied to appear in the printed Transactions of the American Institute of Electrical Engineers, and should not remain uncontradicted.

Lastly it must be remembered that the magnetic clutch of this electric brake has to bear on the surface of a flat disc cast upon the car wheel. This can hardly be called "ease of application," for the brake cannot be applied to the ordinary type of street car wheel. It requires a special casting to be made on one wheel on each axle. This on a large system means an additional outlay for wheels, as "extras are charged for."

We have purposely avoided tabulating the fatal accidents in the last twelve months, directly due to inadequate braking facilities. It, however, is timely to call attention to the charge of Judge Lippincott to the Grand Jury of Hudson County, New Jersey, last month. He devotes special attention to the subject of "killing by the trolley," which he characterized as being sometimes manslaughter. He said, "Deaths by accident have become very frequent. Personal injury, not resulting in death by accident, has become frequent. Now, from mere unavoidable accident, resulting in death or personal injury, no liability whatever arises, but the general rule of law is that where death or other personal injury results by reason of the omission on the part of another to discharge a legal duty, there a criminal liability arises for manslaughter in the case of death, or for an assault and battery where death does not ensue. If the neglect of a legal duty is the cause of death, the person guilty of such neglect is chargeable with manslaughter. If death does not result, but only other personal injury, then he is chargeable with assault and battery. The law imposes upon every one reasonable care in his acts toward another. There is a legal duty owing from one to the other, and a negligent omission of the performance of that duty, resulting in death or other bodily injury, is indictable." He proceeds: "There are many familiar illustrations of these principles of law: a motorman running his electric car along the streets carelessly, negligently, runs over another and kills him, it is manslaughter, although it was not his intention to injure him. A motorman running his car at a dangerous rate of

speed along the streets, running over another by reason of his dangerous rate of speed, the death arising from this omission of duty to run at a reasonable rate of speed, he becomes guilty of manslaughter. If persons in charge of the running of steamboats, railroad trains, electric trolley cars, horse cars or other public conveyances, neglect the duty of using reasonable care and death results therefrom, they are answerable for manslaughter, whether it be in the erection of buildings, the running of machinery, or any other employment."

It will be seen that the judge's charge covers the operating of motors. A jury will certainly class an air brake as being more than a reasonably safe appliance. It is certain that a plaintiff's attorney in prosecuting a suit for damages will call attention to the fact that it was possible for a company to have availed itself of an air brake which would have been reliable.

Recently two verdicts were given against one traction company in New Jersey, one for \$3,000, the other for \$5,000, and there are other suits pending for over \$500,000 damages in that place alone on account of trolley car accidents. Thirty-eight deaths to date are charged against that one road since it adopted electricity.

On September 21st, Motorman Michael Lewis was convicted of manslaughter in the Court of Special Sessions at Newark. Lewis ran the motor car which killed four-year-old Martha Henry on August 4th.

On September 25th, Judge Kirkpatrick sentenced Lewis for one year in the County Penitentiary. The Judge lectured him severely for carelessness and said he felt it his duty to make an example of him. Lewis was crushed by the unexpected sentence. He expected only to be fined and that his company would help him. On the same day motorman Desmond was arrested in Brooklyn for nearly killing a six-year-old girl. His car cut off her right foot. He claimed he did not see her until she was directly in front of the car and that it was impossible to stop it in time.

In Alliance, Ohio, it is recorded that "The motorman, when he found his car going down hill at too great speed, immediately lost his nerve and deserted his post." That car was equipped with a presumably good hand brake. This would not have occurred, had a good air brake been available.

More than one motorman has lost his reason as the result of a fatal accident. Recently a motorman committed suicide owing to his remorse for having run over a child. It may be said this was not his company's affair, but had this unfortunate man had a power brake at hand, he would not have killed the child and taken his own life. In a sense we are our brother's keepers. Would it not be well to place in every motorman's hand apparatus which would render indictment by a grand jury out of the question?

There are some railway men who complacently tell us they have no accidents on their road. It may be that such fortunate individuals exist, but we have not found them. It is somewhat curious that after men made this statement there were bad accidents on their roads.

The newspapers have been hounding the fraternity so much in Brooklyn and elsewhere that trolley accidents have become household words or a subject for jest.

There is no part of electric or cable railroading so important as the ability to stop cars quickly and to keep them stopped! This is specially true where electric or cable cars cross steam roads at grade. At such times hand brakes show their inherent inadequacy.

We do not advocate the adoption of a scientific toy, but submit for your consideration the fact that you can procure at comparatively low cost air brakes which are positive, simple, economical and highly efficient, and which have been tested in the crucible of daily operation.

In advocating the adoption of air brakes we are often told by railway men, "We haven't time for experiments. Let somebody else do the experimenting and then we will look into the thing." Had this position been taken by progressive men would there be a single commercial electric motor in existence?

The experimental stage was passed long ago, and with 350,000 air brakes on locomotives, passenger and freight cars, it is untimely to talk about experimenting, for steam roads and surface roads have much in common. If a freight car loaded with pig iron needs an air brake, how much more is one needed to brake a car carrying living beings?

There are air brakes and air brakes. Of the merits of the different ones, buyers will do well to satisfy themselves before contracting.

The all important question is whether the first cost of a good air brake is too high, or not, in proportion to the advantages gained. No accountant can figure accurately how many dollars of damage claims will be avoided; nor how much revenue will be increased by the quicker schedules made possible with air brakes (for even seconds count); nor what the gain in labor account will be by not being restricted to hiring

any particular height or weight of man; or how much the life of car body, truck and motor will be prolonged. There is a decided gain from whatever point we view the air brake, and with an air brake an employe is armed at all points.

Will it not be worth your while to give this braking matter earnest attention? If but a few of this audience will determine to investigate the advantages of the air brake over all other forms of brakes, this paper will not have been prepared in vain.

It was written to suggest the value of good power brakes over hand brakes, in minutes snatched from busy days.

## CAN THE T RAIL BE SATISFACTORILY USED IN PAVED STREETS.

A Report to the American Street Railway Association by S. Hendrie, Manager Wyandotte and Detroit River Railway.



STRATHEARN HENDRIE.

Strathearn Hendrie, was born in Detroit, Mich., 28 years ago, was nursed on street railways in infancy, and has continued in that line ever since. His father was treasurer and general manager of the old Detroit City Railway. This progressive young man began his active street railway career in 1887, with the Detroit City Railway, two years later being made treasurer and assistant to the president and general manager, holding that busy position until 1891, when he went out with the other old stockholders, and the lines were sold to the Detroit Citizens Railway Company. He has always been interested in the suburban railway idea, and in 1892 consolidated the Detroit Electric Railway, East Detroit & Grosse Pointe Electric Railway, the Jefferson Avenue Railway and the Gratiot Avenue Railway, in all of which he had been previously interested, into the Detroit Suburban Railway Company, which he sold to the Detroit Citizens' Street Railway Company. Mr. Hendrie represented the Wyandotte & Detroit River Railway in the convention, and is interested in the extension of the Detroit, Rouge River & Dearborn Railway, and other suburban plans. His paper is prepared, so that it will be of use by railway companies in their arguments with city officials.

GENTLEMEN: For reasons unnecessary to mention your committee's report has been prepared with more haste than the subject deserves, and you will undoubtedly find it incomplete in many details. A vivid recollection, however, of the disappointment of your members at previous meetings when papers have failed to materialize, has emboldened us to present this report in its incomplete state, as better than no report at all and as continuing the discussion of a subject in which so much interest was expressed at the last convention.

We would preface our report by the explanation that we have considered the word "satisfactorily" as applying to the point of view of the city and the driving public, as well as that of the company, and we will endeavor to show that the T rail is not only satisfactorily used in paved streets, but that it is the best rail for the purpose.

The tendency of the larger cities in this country—in fact we might say in all the cities of this country—during the past ten or twelve years has been towards smoother and better paved streets, and the general public, watching the progress of its city officials, has become in many places impatient of the action of the street railway people in maintaining the old forms of rail which make a ridge on the smooth surface of a first-class modern street in an American city. Our travelers have come home from England and the continent extolling the grooved rail, and our city officials have in many cases forced either the English grooved rail or its American modification upon the railway companies. No street railway man hankers after the grooved head before he gets it, or enjoys it after he has put it in, and he therefore fights its introduction, demanding to be left alone, as he was, with his center-bearing or five inch tram head. What we would show him—and through and beyond him his public—is that he can progress in the direction of their desires for a smooth street, and can give them something even more satisfactory to them than their favorite grooved rail.

For the street railway men, questions of price, joints, quick delivery, competition, coal pile, and construction, combine to recommend the T rail. The old argument for the tram head—that the steel paving for the three inches is the cheapest in the end—no longer holds good in these days of good street pavements and rapid transit. Wagon traffic goes where it belongs—on the side of the street. To those who can still use

the clean headed old center bearing rail, we can only say, "You lucky dogs"; to most of us it is lost forever. As a substitute for this, where old grants are being renewed or new ones made, the grooved headed rail has been in many places hastily, and, we believe, unadvisedly required. While the suggestion of a T rail, for use in paved streets in cities, is startling to the average citizen, alderman, or city engineer, and is in most cases impatiently rejected by them, yet we must recollect that the mention of a rail such as steam roads use, calls up in their minds the idea of four or five inches of steel standing up above the street and of dilapidated plank crossings with half-drawn spikes, and we should go patiently to work to teach them that as there is more than one way to supply motive power to a car, so there is more than one way of putting a rail in the street.

To aid you in this, we have prepared a list of twenty-six cities in which the T rail is used, with remarks thereon (to be found at the end of this paper), kindly furnished this committee by the railway companies in answer to a list of questions sent out; and we might also say that there are over fifty other members of this association whose roads are reported in the railway publications as being partly or wholly constructed of T rail, who declined or neglected to answer the inquiries of your committee. The general consensus of opinion of the twenty-six roads referred to, and of the officials of the cities in which they run, is that if you can once get down a hundred yards of T rail and make a decent job of the paving, neither the officials nor the citizens will permit you to use anything else in the future. The main thing is to make your paving job a neat and good one. In three of the other cities, where there is at present no T rail, but which are blessed with enlightened city officials, the T rail is about to be made a requirement on the companies.

Modern street railway construction and street paving imply a broken stone, concrete or other solid foundation, a high girder or T rail, and a brick, asphalt or granite surface to the street, in the larger cities, or cedar block, cobble or macadam in the smaller ones.

Asphalt or macadam can be paved as easily to a T rail as to any other. They should be laid flush, and room should be made for the flange by running a railroad freight car, or other car having a larger flange than the street car, over the track before it is opened for traffic. Bricks are now molded by many paving brick manufacturers to fit girder and T rails, those for the latter allowing a small space for the flange of the car wheel. Whether it is more expensive to chip the corners of granite or Medina blocks, or to leave them intact a short distance from the head of the rail and fill the space thus made with asphalt, creosoted wood or concrete, is open to question, but, in either case, a first-class job can be made. The writer is familiar with two excellent pieces of 56 pound T rail construction on chairs, in one of which the pavement consists of six-inch cedar blocks, and in the other of small three or four-inch cobble stones, both paved close to the rail with no filling.

It may be useful, in your arguments with city officials in favor of a T rail as against a grooved girder, to insist that a T rail is a girder rail with a head differing less from that of the grooved girder than this does from the tram or center bearing head. Also the substitution, in this country, of the steel base and upright member of the girder for the wooden stringer, took place before the introduction of the grooved rail, and was due to entirely different causes and certainly has not been brought about by any demand for smooth streets originating with the cities or citizens. Such substitution is equivalent to that of steel for wood in buildings. The girder is an established fact; its grooved head, we hope, is merely a passing fancy. The grooved rail might easily be a big headed T out of which a piece corresponding to the groove had been planed. This can easily be shown by reference to cross sections. And we should bear in mind that if we hope to peacefully and with good feeling avoid the use of a grooved rail, we must do so, not by demanding obstinately what we know in our inmost minds to be reasonably objectionable, to be bad practice, to be obsolete, but by presenting to the public, and educating it up to, a rail which shall, from its point of view, be as far ahead of the grooved rail as that is ahead of the tram or center bearing rail. And we should also bear in mind that the public will demand and in the long run will secure streets satisfactory to itself.

Your committee has not gone more fully into the details of construction from a street railway man's point of view, because these must necessarily vary in different localities; but it suggests that the progress which has been made in girder rail construction in the past two or three years should not be lost sight of when we secure the T. Have it big enough and heavy enough.

As it may be of use to members of the association, your committee has attached to this report, in the form of an appendix, a list of the street railways which have answered its queries, together with a synopsis

## Street Railway Review

## T RAILS IN PAVED STREETS

PLACE	COMPANY.	RAIL IN PAVED STREETS.				CONSTRUCTION.	PAVEMENT.		FILLING.	REMARKS.
		Miles T.	Other Rail	Weight.	Height.		Inside.	Out-side.		
Augusta, Ga.	Augusta R'y Co.	.5	3.5	56 lb.	3½ in.	Ties 3 ft centers steel chains.	Brick.	3 in. brick, then asphalt	None.	Public & officials think it better than girder.
Bay City, Mich.	Bay Cities Consolidated R'y Co.	8	11	60 lb.	6 in.				Oak strip, gravel, etc.	City engineer and B of P W. think it the only rail.
Boston, Mass.	West End St. R'y Co.	24	21.5	35 to 100 lb.	1½ to 9 in.	Largely 6 in. rail or stringers and 9 in on ties, with tie plate.	Granite block	Same		City officials & public are not in favor of it.
Columbus, O.	Columbus St. R'y Co.	.5	54.5	60 lb.	6 in.	Ties 2 ft. centers broken stone ballast	Brick	Same	Hard wood covered with coal tar.	No complaint; more will be laid.
Denver, Col.	Denver City Cable R'y Co.	6			4 in.	Cable; yokes 4 ft apart.	Asphalt with stone toothing	Same	None.	Makes a good street.
Denver, Col.	Denver Cons Tram way Co.	6.75		48 to 72 lb.	3¾ and 6 in.	6 in. concrete under ties; concrete between ties.	Stone blk next rail, then asphalt	Stone block	Oak strip bedded to fit.	
Des Moines, Ia.	Des Moines City R'y Co.	2	15.23	60 lb.	6 in.	Spiked to ties.	Brick			Public & city officials like it.
Duluth, Minn.	Duluth St. R'y Co.	16	10		5¾ in.	Ties 2 ft. centers. oak stringers.	Cedar block.	Same.	Block cut or notch'd	All like it.
Fort Wayne, Ind.	Fort Wayne Elec R'y Co.	8	7	60 lb.	6 in.	Ties 2 ft.; tie rod, 10 ft.	Brick, block and cobble-stone.	Same.		The Company now reconstructing entirely with T rails.
Houston, Tex.	Houston City Street R'y Co.	9	1	45 lb.	4¾ in.	Ties, and chairs and stringers.	Brick, cyprus, gravel, Bois d'arc, rock	Same.	Concrete	Gives satisfaction.
Lincoln, Neb.	Lincoln St. R'y.	15			5¼ in.	Ties 2 ft. centers.	Brick, cedar.	Same.	Sand with brick.	Have only two curves now, but intend to lay track
London, Ont.	The London St. R'y Co.	1	11.5	56 lb.	4 in.	Cedar ties, gravel ballast.	Gravel.	Macadam.		Not favored. Note: Pavement is not good.
Marinette, Wis.	Marinette Gas, E. Light & St. R'y Co.	4		40 to 60 lb.	3½ and 6 in.		Wood block.	Same	Wooden strip to fit	All are well pleased now.
Minneapolis, Minn.	Twin City Rapid Transit Co.	5	35	60 lb.	5¾ in.		Cedar or granite.	Same.	Pine or oak strip.	City engineers approve.
New Haven, Conn.	Winchester Av. R. Co.	11		52 to 72 lb.	1¼ & 4¾ in.	On chairs and on ties.	Half blk half cobble.	Same		The common council will have nothing else.
Norwalk, Conn.	The Norwalk Street R'y Co.	3		60 lb.	6 in.	Three brace chairs to each rail	Blocks & cobbles.	Blocks & macadam		Gives satisfaction.
Norwich, Conn.	Norwich St. R'y Co.	1.2		48 lb.	4 in.	Chairs and stringers.			Gravel	Is not favored much.
Port Huron, Mich.	The City Elec. R'y Co.	5		45 lb.		Cedar ties, and pine stringers.	Cedar block.	Same.	Oak strip inside, pine strip outside.	Gives satisfaction.
Racine, Wis.	Belle City St. R'y Co.	2.27	2.773		4¾ in.		Brick.			Public & officials like it.
Salt Lake City, U. Ter.	Salt Lake City R. Co.	3.		72 lb.	6 in.		Sand-stone block.	Same.	Sand	Public & city officials well satisfied.
Savannah, Ga.	City and Suburban R'y.	1	8			Chairs or stringers.				Not favored.
Springfield, Ill.	Springfield Consolidated R'y Co.	22		40 and 60 lb.			Beveled brick or block			Gives satisfaction. Authorized by city council.
Springfield, Mass.	Springfield St. R'y Co.	15		56 lb.	4 and 4¼ in.	On stringers and on ties and chairs.	Granite and cobble.	Granite, macadam	Asphalt and brick	No complaint; evidently satisfactory.
Waterbury, Conn.	Waterbury Traction Co.	8			6 and 7 in.	Spiked; ties 2 ft.	Belgian block for 7 in. rail; cobble stone for 6 in.	Belgian block.	None	None better, when properly laid and paved to
Windsor, Ont.	Sandwich, Windsor and Amherstburg R'y.	3	1	56 lb.	4¼ in.	Steel chairs; ties bedded in gravel, then inch board & block paving.	Cedar block.	Same.	None	Preferred to girder rail.
Wyandotte, Mich.	Wyandotte and Detroit River R'y.	2		56 lb.	4¾ in.	On broken stones.	Macadam	Same	None	No objections

of the answers, regretting that, out of one hundred and seventy-eight letters sent out with stamped envelopes for reply, it received but eighty responses, and, as above stated, of the ninety-eight who failed to come to time, more than fifty are using the T rail, but whether in paved streets or not is unknown.

## T RAIL NOT USED IN PAVED STREETS.

- Baltimore, Md. City & Suburban Railway Co. Not allowed.  
 Baltimore, Md. City Passenger Railway Co. Not allowed.  
 Buffalo, N. Y. Buffalo Railway Co. Prejudice.  
 Carbondale, Pa. Lackawanna Valley Passenger Railway Co. City Council considering the question.  
 Chicago, Ill. City Railway Co. Not allowed.  
 Chicago, Ill. West Chicago Street Railroad Co. Not allowed.  
 Chicago, Ill. Passenger Railway Co. Not allowed.  
 Cincinnati, Ohio. Cincinnati, Newport and Covington Railway Co. City Engineer favors a trial.  
 Cincinnati, Ohio. Inclined Plane Railway.  
 Dayton, Ohio. Wayne and Fifth Street Railroad Co. City opposed.  
 Denver, Col. West End Street Railroad Co. Use T rail, but track not paved.  
 Derby, Conn. Derby Street Railway Co. City favors it.  
 Falls River, Mass. Globe Street Railway Co. City opposed.  
 Grand Rapids, Mich. Cons. Street Railway Co. City opposed.  
 Hamilton, Ont. Hamilton Street Railway Co. Not allowed.  
 Johnstown, Pa. Johnstown Passenger Railway. Not allowed.  
 Kansas City, Mo. Metropolitan Street Railway Co. City opposed.  
 Mobile, Ala. Mobile Street Railroad Co. City Engineer favors it.  
 Norfolk, Va. Norfolk Street Railroad Co. City Engineer opposed.  
 Nashville, Tenn. Nashville Street Railway. City requires girder rail.  
 Omaha, Neb. Omaha Street Railway Co. Not allowed.  
 Philadelphia, Pa. Philadelphia Traction Co. Not allowed.  
 Pittsburg Pa. Citizens Traction Co. Not favored.  
 Pittsburg, Pa. Federal Street and Pleasant Valley Passenger Railway Co. Not allowed.  
 Sandusky, Ohio. Sandusky Street Railway Co. Not favored.  
 St. Louis, Mo. Missouri Railroad Co. Not allowed.  
 St. Louis, Mo. Southern Electric Railroad Co. Not allowed.  
 St. Louis, Mo. St. Louis Railroad Co. Not allowed.  
 St. Louis, Mo. Citizens' Railway Co. Not allowed.  
 St. Louis, Mo. Cass Avenue and F. G. Railway Co. Not allowed.  
 St. Louis, Mo. Lindell Railway Co. Not allowed.  
 St. Joseph, Mich. St. Joseph and Benton Harbor E. Railway and Light Co. Not favored.  
 Springfield, Mo. Metropolitan Electric Railway Co. City opposed.  
 Williamsport, Pa. Passenger Railway Co. No objection.  
 Wilmington, Del. City Railway Co. Not allowed.  
 Youngstown, Ohio. The Youngstown Street Railway Co. Public opposed.  
 Akron, Ohio. The Akron Street Railroad Co.  
 Brooklyn, N. Y. Brooklyn City & Newton Railroad Co.  
 Brooklyn, N. Y. Atlantic Avenue Railroad Co.  
 Cleveland, Ohio. City Railway Co.  
 Chicago, Ill. Calumet Electric Street Railway.  
 Camden, N. J. Camden Horse Railroad Co.  
 Jersey City, N. J. Cons. Traction Co.  
 Milwaukee, Wis.  
 Montreal, Que. Montreal Street Railway Co.  
 New York, N. Y. Dry Dock, E. Broadway and Battery Railroad Co.  
 Newark, N. J. Newark & S. Orange Railway Co.  
 Newark, N. J. Cons. Traction Co.  
 Portland, Ore. City & Suburban Railway Co.  
 Pottsville, Pa. Schuyler Electric Railway Co.  
 Philadelphia, Pa. Hestonville, Mantua & Fairmont Park Railway Co.  
 Reading, Pa. Traction Co.  
 Toronto, Ont. Toronto Railway Co.  
 Washington, D. C. Washington & Georgetown Railroad Co.  
 York, Pa. York Street Railway Co.  
 New York, N. Y. Third Avenue Railroad Co.

## "CITY AND SUBURBAN ELECTRIC RAILWAYS."

A Report to the American Street Railway Association, by E. C. Foster, Lynn & Boston Street Railway.

### THE AMERICAN STREET RAILWAY ASSOCIATION.

GENTLEMEN:—The subject that has been assigned to me for discussion, that of "City and Suburban Electric Railways," is decidedly a comprehensive one. Inasmuch as the interurban electric railways are comparatively few, it covers nearly the whole electric railway field. The latter class of roads is a growing one, however, and, as my work is in connection with lines of this kind, connecting Boston with the smaller cities surrounding it on the north, I shall assume that it is excusable in me to devote a considerable part of this paper to the consideration of the interurban roads.



E. C. FOSTER.

It is difficult to make the distinction between city roads and suburban roads. The function of nearly all city roads is largely to convey the people from the residential districts, mainly in the suburbs, to the business sections, and likewise, from the latter to the former. In the improvements it has made in this class of transportation, lie the greatest benefits of the application of electricity to street car propulsion. The growth of our great cities has resulted in the appreciation of value of all real estate near the business sections, to a point where the only residence a workingman can afford in these districts is a tenement house. These tenements are invariably crowded to a degree that is unhealthy. That the electric railway has done much for humanity in enabling the working population to leave these homes in the congested districts, and procure more comfortable and respectable ones in the suburbs, goes without saying.

Next to this most important use of the electric railways comes their use in furnishing recreation for the masses of the people. Nothing accomplishes so much in the elevation of our population as frequent opportunity to cultivate acquaintance with nature. Optimism is the natural and healthy condition of the mind, and nothing encourages one to look on the bright side of life as does a ride or ramble through the country. The combination of fresh air and pretty scenery makes the only tonic that tones. The two necessary considerations in the accomplishment of the scheme of country air for the masses are, first, the public parks, and second, the means of transportation to them. It is only within the past year that, in the state of Massachusetts, a State Public Park Commission has been created, for the purpose of purchasing large tracts of land and opening them to the public, that they may enjoy the beauties of nature without trespassing upon private property. On a portion of the Blue Hills, only ten miles distant from the heart of the city of Boston, over 1,200 acres have been secured to be preserved forever for the benefit of the people. Also, in Arlington, a like distance in another direction, a large reservation is made; Middlesex Fells in another, and the Commission is now turning its attention to the shores of Revere Beach, immediately north of the city, one of the grandest beaches of this continent. It is needless to add that the street railway companies are doing their share in the matter of providing the necessary transportation. While their motives are not purely philanthropic, the results accomplished are of almost as substantial benefit as though the people only were considered. While this fact is very greatly appreciated, there seems to exist a growing feeling, on the part of some, that the street railway companies get everything and give nothing. Certainly the very evident benefits the people have secured, coupled with the fact that few companies have earned more than moderate dividends, and many none, should be enough to convince the most skeptical that the stockholder's experience is not always a profitable one.

However, I presume that it was not expected of me to devote this paper to a demonstration of the advantages accruing from the existence of electric railways, but rather to consider the question of the operation of roads and the projection and construction of new lines. It seems almost useless for me to tell you, who know, certainly as well as, if not better than I, how to operate existing roads, and how to determine what lines will pay, and under what conditions of fares and traffic. When I say, hereinafter, that such a thing should be so, even though it be without modification, you must understand that I offer such only as my opinion, formed from my own experience, and not necessarily as an established fact.

"I CAN'T take this transfer, sir," said the conductor, "It is punched for a man with a smooth face, while you wear full whiskers." "That's all right," replied the passenger, "they grew while I was waiting for the car."

As a road is projected, and studied from a financial point of view first, then constructed, and then operated, it may be well to consider these topics in this same order. The first point, covering the work preliminary to the construction, admits of nothing but rather general discussion. As it is not the purpose of this paper to consider roads built to yield their dividends in benefits to allied interests, as in developing real estate, it may be taken for granted that the question of primal importance, in the consideration of a proposed line, is its probable earning capacity. The stimulation to the growth of the country crossed may be considered only in the reflex effect that such growth may have upon the business of the road. A line to pay should be one that makes itself a necessity to the people, in offering them the best facilities for transportation in the particular direction. Competing lines should be avoided, excepting where the volume of business is large enough to support both. Besides the assurance that the line is necessary to the people accommodated, it must be ascertained that the number of the latter is large enough to support the road on a paying basis, not only the first year, when the repairs are slight, but later, when reconstruction becomes necessary. I consider that there are very few cases where a company is warranted in investing its money in a line, on the strength alone of the future that may be expected from it. A road should be, at least, capable of earning its operating expenses from the start, and the evidence of a more prosperous time, later on, should be very strong, before it is constructed without immediate promise of good dividends. It is sometimes necessary for an established company to build on a location, merely to keep out competition. The only thing that warrants this is the knowledge that the opportunity exists for the proposed competing company to be self-supporting from the start, and ultimately a serious rival. Otherwise it is economy to allow them to build the road and buy them out at the foreclosure sale.

Track construction is a subject that has been so thoroughly discussed in all its details that I shall not attempt to do more than express my opinion, in a general way, as to what forms are best suited for the various demands of the suburban roads. The kind of construction most desirable for a certain location depends, of course, entirely upon the particular conditions. For roads connecting towns, I think that it is often possible to secure an independent right of way for a very slight cost per mile, and very often for nothing; this might require special legislation. Progressive land owners realize that the one way to enhance the value of their real estate is to put it within means of easy communication with the surrounding neighborhood, and especially the principal town. For this reason they are often willing to give the necessary land for an electric railway—without any undesirable conditions or restrictions—and oftentimes to contribute something toward the grading. If, in this way, the right of way can be obtained that is desirable as to route and grade, it offers many advantages that cannot be had on public highways. For such a right of way the regular steam road form of construction would be employed. About a 60 lb. T rail 6x7 in. oak or chestnut ties, laid 2 ft. centers, needle switches with lever throw, etc., would give a track that would allow a speed of forty miles an hour, making it necessary to slacken speed only for curves, and as much for switches as the overhead construction demanded, the track switches requiring no reduction of speed. Curves, in such a road, should be few, and of the longest possible radii.

Where it is decided to build on country roads, a location at the side of the road is, of course, preferable. Here T rail may be laid, and the track filled with gravel, covering the ties and leaving the heads of the rails entirely exposed.

In the streets of smaller towns, where permission can be obtained, it is also desirable to lay T rail, although there is always more or less trouble maintaining the paved brow that is usually required, and consequent difficulty in plowing snow from the track, due to the shears and diggers of the plow striking the partially displaced blocks.

In city streets, and others that are paved, the girder rail seems to be the only one suitable. In order to obtain the necessary depth for paving, this rail should be nine inches deep, and should weigh about ninety pounds per yard. This makes very expensive construction, but the expense is justifiable when the conditions are considered. While such construction is necessary, where laid in streets paved from curb to curb, it is an open question in my mind as to what is best in macadam streets. There are many lines that are operated on 15 or 30 minutes, or even on hourly intervals, where the business is hardly such as to warrant the use of track construction costing from \$20,000 to \$30,000 per mile. The frequency of the service is an important factor in determining the most economical construction for use under particular conditions, and I think that the nine inch girder rail ceases to become a necessity, and becomes a luxury, when the number of cars run over it daily is reduced below a

certain figure. Further, there are positive objections to the use of such rigid construction as this in dirty streets, as in macadam streets where the top dressing contains a great deal besides stone. My experience has been that the rail becomes covered with dirt, and that the cars rattle and "chatter" badly in running over it, more than in running over a dirty rail of less rigidity. It may seem revolutionary to suggest it, but I think that, for certain places, it is at least worth while to consider relaying good tram rail, using some approved form of joint plate. I am not quite convinced in my own mind that there are conditions existing where this is warrantable, but the subject is certainly worthy of discussion and consideration.

Overhead line construction has kept pace in its improvements with those of the other branches of electric railway work, and the success that has been had with the lines built during the early periods of development encourages one in the belief that modern lines may be depended upon to give little trouble.

Regarding equipment, my idea is that the longest car that can be operated successfully on four wheels is the most desirable for the ordinary conditions. For long distance lines having heavy traffic, I would recommend thirty foot bodies, on double trucks, for box cars, and fifteen bench open bodies, on similar trucks. Where there is a sufficient demand, I would run a combination smoking and baggage car as the trail car of a train of two.

In building a new road for short distance travel, I would give all curves the necessary radii for the use of seven foot wheel bases through them, and have trucks this standard. On these trucks I would use twenty foot box cars and ten bench open cars, either class measuring about twenty-nine feet six inches over the buffers. As a supplement to the regular equipment of motor cars, I recommend trailers, and that they may be run economically, a power brake is necessary. To meet this demand, the air brake is being developed, and promises to fill the requirements. For convenience in attaching trailers to motor cars, automatic couplers are necessary. There are several forms of latch couplings that can be made to do the work satisfactorily. An important thing in connection with the use of trailers is the adoption of, and adherence to, a standard, that all buffers and draw bars may be of one height, and other parts right for the proper operation of cars in trains.

For electrical equipment, it goes without saying that the modern multipolar, single reduction motors, with series parallel controllers, are the only ones that a road can afford to use. The performance of the various equipments, now manufactured by the different companies, has been so universally satisfactory that I feel that a great deal has been accomplished in the past two years in the development of the car equipment.

I am a firm believer in the desirability of heating all cars in the North thinking that it has a very important effect upon receipts. As much as I like the results obtained from electric heating, I hardly feel that we can depend upon this method. Our experience is that it takes from eight to twelve amperes to keep a twenty foot car comfortable, that is, forty degrees above the outside temperature. This means that it requires about as much current per hour as to propel a car four miles. This would make seventy-two car miles of power per day of eighteen hours, chargeable against the heaters. When it is considered that this extra power is often demanded when power is needed for other purposes, as in snow storms, it may be seen that, aside from the question of cost of coal, the consideration of the necessary increased capacity of the power station and feeder system is an important one. Having put myself on record as opposed to electrically heated cars, it is probably expected of me that I present a method that is satisfactory. Unfortunately, though this I am unable to do. For short trips, run from a car house, the hot water storage system may do. We still depend upon the stove, and "with all its faults we love it still," until we can find something that we consider an improvement upon it.

It is not improbable that before long, a telephone will be considered a necessary part of the equipment of each car operated on suburban lines. It often happens that means of communication with the nearest car house, or with the starter, would save much delay, and even danger, in cases of cars disabled or, thrown off their schedule time by other causes. Either a telephone in each car, with means of plugging in on convenient poles, or 'phones, arranged at the turn-outs, in boxes, may be used. As a substitute for this arrangement, or in connection with it, a system of signals between turn-outs may be desirable, under certain conditions. By the use of lantern boxes, containing incandescent lamps, and the necessary hand or automatic switches, a simple system of signals may be devised, by means of which cars running between turn-outs on single track lines will be protected from meeting other cars.

While these devices may be necessary in some cases, they will always be more or less burdens, in the complications they add. The signal system, especially, has one important objection. Regardless of the most carefully enforced rules to the contrary, men will learn to consider it as freeing them from the necessity of maintaining the same careful lookout for approaching cars and in cases of failure of the signals, accidents will be more likely to occur than they would without the signal system.

The adoption of a proper schedule of fares and transfers is a most important matter. Where lines are short enough to allow the use of the one standard fare throughout, this question is a simple one, but where routes are longer, and it becomes necessary to collect higher fares, complication commences. When this latter condition is aggravated by systems of transfers, the complexity increases. My experience has been that, in general, it is best to divide such a line into sections, collecting a single fare each, and registering all as the standard fares. These sections are arbitrary, of course, but in our case are determined by town boundary lines. For instance, where we have a line running through several towns, we collect a single cent fare in each town. In connection with this, I would say that there are instances where further restrictions need to be made. Cases have arisen where towns of large area have comparatively small centers of population a long distance apart. Single fares have been established as being good anywhere within the limits of either town. A line is then built connecting the two towns, and instead of ten cents, it is considered necessary to get fifteen cent fares. The question then arises as to how the required three sections can be arranged. According to established precedent, the five cent fare sections include each whole town, although the line in question did not exist when this understanding was originated. In this case, however, it becomes necessary to establish the third section as including that part of the line between the boundaries of the more thickly populated portions of the towns, and including the intervening open country in both towns. As an exception to this method of paying fares "on the installment plan," I would mention the case where there exists a very heavy through traffic on a line, compared with which the local traffic is slight. In this case I consider it best to collect the whole fare at once, issuing to the through passengers conductors' private checks. These latter are held by the passenger, as evidence that he has paid through fare, and surrendered to the conductor before the end of the trip.

The selection of the best rates of fares is a matter requiring the consideration of numerous conditions governing the particular case in question. It is safe to assume that the result to be worked for is the earning of the largest possible net revenue, considering, at the same time, the development of the business. Exactly the best way to accomplish this is the problem to solve. The expense of operating may be approximated reasonably close. It is more difficult, however, to determine the amount of traffic that different rates of fare may bring. It is well to study the classes of travel that may be expected, and fix such a basis of rates as will probably yield the largest margin of profit. After having done this, the basis thus determined may be increased by a considerable percentage, and this new basis adopted as one to use in opening the road. As every one knows, it is a simple matter to decrease fares, and, while I do not believe in starting out with high rates merely for the opportunity of obtaining the credit of cutting them at some future time I do consider that it is necessary to have a margin of safety, to avoid the possibility of being burdened with rates that are too low, and cannot possibly be raised. In this state, with the existence of a law making it illegal for railroad companies to withdraw transfer checks issued without permission from the Railroad Commissioners, it becomes more than ever necessary to very carefully consider all proposed changes, studying them especially as to their probable effect in the future, when the road has developed and taken in new territory. It is aggravating to see the opportunity for a new line, into a district that might naturally be expected to pay, by means of a rate of fare higher than the standard, and have the fact of a previously established rate, that can be construed to cover the line in question, standing in the way of the consummation of the scheme. I consider  $1\frac{1}{4}$  cents per mile a minimum rate for the basis of a system of fares, no fare to be less than five cents, and would advise the establishing of higher rates, up to two cents, as the particular condition would seem to recommend.

In certain cases I think it advisable to sell round trip tickets. Our fare from Lynn to Boston is 15 cents, but we sell two tickets for 25 cents. We think that the possession of this return ticket leads people to use our cars when they would otherwise patronize the steam roads. We have no other commutation, excepting workmen's ticket over certain routes, good only during the hours of 6 and 7, morning and evening.

Transfers may be used within reasonable distances. The system must, of course, be carefully worked out, to avoid the possibility of abuse. In

all of our efforts to be just to the public we cannot lose sight of the fact that the public is not just to us when it can avoid being, and that it behooves us to take the necessary precautions to protect ourselves, inasmuch as the popular moral code includes no provision for our protection. The existence of this unfortunate condition of affairs demands that we use care to prevent the abuse of the privilege we grant the public, the most common form of which abuse is the failure to observe the "not transferable" restriction.

Suburban roads work at a disadvantage compared with city roads, when the question of operating expense is considered. There are many reasons why a given number of cars can be operated for less money, within a small territory than when spread over a large area. These reasons are obvious. In the former case a large number of cars may be cared for in one car house, thus allowing a minimum expense of maintenance. A small car house cannot afford the motor tables, traveling cranes, etc., that do so much to lessen the cost of motor and truck repair, nor can the work of the small house be divided among different men, giving each his specialty, as in a large house. In one of the largest car houses in the world, the Lenox street house of the West End Street Railway Company of Boston, two men fill all grease cups, examine and replace brushes, and inspect other parts of the motors of from one hundred and twenty to one hundred and fifty cars daily. The other work in this house is divided up among some twenty men, including carpenters and blacksmiths, so that the average is about six cars per man. This number of cars per man is often assigned, but probably the work is seldom so well done as in this house. Another important disadvantage under which the suburban road labors is that of the high cost of power. It usually is dependent upon a number of small stations, due to the fact that it is impossible to cover the necessary territory from one station, and both the labor and coal consumption of small stations are necessarily greater per car mile than are those of large ones. The opportunities of making the expense in the first instance, that of car house work, compare favorably in the small house with the large are rather few. They lie in the dependence upon one capable man, circulating among the houses, directing the efforts of lower priced labor. Another idea that suggests itself is the equipping of one house with a complete outfit of labor saving appliances and bringing all unusual repairs to this house. This is objectionable, however, in that it requires the moving of cars over long distances, at a time when they are least in condition; and, further, that it makes two gangs of men responsible for the care of the cars. Regarding the elimination of the difference in power costs, now existing in favor of the city road, the indications are that the time is coming when it will be no longer necessary for the country road to maintain its numerous steam plants. I refer to the probable introduction of the alternating system of long distance electrical transmission into railway work. Suppose the case where it becomes necessary to distribute power for railway purposes over large areas, as on many suburban roads where several power stations are now used. With this system there need be but one main power station, which can be located at the point possessing the greatest advantage for cheap production of power. At various selected places rotary transformers may be placed, one for each section of road. These receive alternating current, over long distance lines, from the main station, and deliver it as direct current to the trolley wires, or possibly to such local feeders as may be necessary for the distribution throughout the particular section. These rotary transformers require only the same care as generators. Beside them, the only apparatus in the sub-station, needing attention, would be the circuit breakers. The latter would be arranged between the rotary transformers and the lines, in the same way that those in the present stations are. It will be seen, therefore, that one ordinary dynamo tender would be all the labor required in a sub-station. Further than this, the sub-station might often be in car houses, where one of the regular employes could care for the machinery, thus reducing the labor charge to a minimum. By this arrangement, power could be distributed to cars operating over areas of from twenty-five to fifty miles radius from one station, at cost slightly above that for distribution within the ordinary distances of present practice. I am told, that with such a system, using 6,000 volts, three phase currents, from a station located at the central point, we could supply power, by the use of three No. O B & S. wires, to a road fifty miles in length, when fifty cars were being operated. The total efficiency of this transmission, neglecting the loss in the trolley wires, would be about 65 per cent. These fifty cars, on the fifty mile road, would give fifteen minute headway, with a speed of eight miles per hour. With the higher speed, that would more probably fit the conditions of such a road, the number of cars would be reduced, allowing a proportionate decrease in the size of the wires, so long as the current allowance, 20 amperes per car, was sufficient. To accomplish these same results with the present

system of 500 volts, would require 600 No. 0 B. & S. wires, the cost of which would, of course, be impracticable.

While this system has many advantages which are sure to result in its extensive application, it has its attendant disadvantages, which must be overcome. Most important of these is the difficulty of insulating the lines. Practice has been to use bare wire, simply because the covering is of no use with such voltages. The principal use of the insulation on the majority of overhead wires is a sentimental one. The public prefers the appearance of the covering to the bare wire. It is probable that it will be wise to recognize the existence of this preference, and cover the wires, merely to save comment. The most serious difficulty, however, lies in the fact that it seems to be absolutely necessary to keep the wires out of the trees. Mr. George D. Johnson, superintendent of the Hartford Electric Light Company, writes that a twig short circuits their 5,700-volt mains, almost as readily as a wire.

It will be evident that the adoption of a long distance transmission system will admit of the use of any suitable water power that may be located too far away to be available under the direct method of transmission.

Although I have discussed no branch of my subject sufficiently in detail to treat it thoroughly, I feel that I have already taken more than my share of your time. In conclusion, I would say that I have very great faith in the future of the electric railway. It has demonstrated its ability to live through periods of adversity. The lesson in economy that the country in general has had, has taught us a great deal with the rest. Roads that have paid expenses, during the past two years, will have nice margins of profits left from the receipts of the years to come, and those that have paid their dividends will pay larger ones, and add to their sinking funds. While a considerable part of the curtailment, made necessary by reduced receipts, has been in the line of the sacrifice of repairs that should be made in prosperous times, there have been many unnecessary expenses brought to light and cut off. Things which we thought necessities proved to have been luxuries, when we learned how well we could do without them. I am a firm believer in the policy of putting everything into the best of condition and keeping it so, as being the one that yields the largest net revenue, present and future, but I realize now better than I did two years ago, that in our zeal to have the best of everything, kept in the best of condition, we allow extravagances to creep in, with the necessary expenditures. The education in economy that we have gained will help us wonderfully in the future, and the combination of increased earnings and reduced expenditures will give an increase in the net revenue that will be substantial.

### DESTRUCTIVE ARCING OF 500 VOLT FUSES.

Special Paper at the American Street Railway Association by  
W. E. Harrington.

The destructive effects of the arc accompanying the opening of 500-volt circuits with switches, lightning arresters and fuses, has led the writer to inquire into these phenomena, particularly in reference to fuse practice. A series of carefully conducted tests were made, to find the relation between the fusing currents of different size copper wires, ranging from No. 30 to No. 21, B & S. gauge, the time required to open the circuit, and to what extent they are contributed to the time required.

An inclined trackway was constructed, having two copper tracks upon which a traveler, consisting of a block of hard wood, having copper plates in contact with the tracks, could run, the circuit from rail to rail of track, being completed through an electro magnet on top of the traveler. Parallel with and alongside of the track was a raised board on which a paper was attached.

An impress was made on paper by a lever on the traveler, when released by electro magnet, owing to stoppage of current. Before tests were made, the trackway was carefully calibrated as regards time for traveler to go from top to bottom and the intermediate points, resulting in knowing the time to  $\frac{1}{10}$  of a second.

The tests were conducted across the bus bars of switchboard of the Camden Horse Railroad Company, Camden, N. J.; average voltage, 515 volts. Before blowing a fuse in circuit, a water rheostat was set, using a Weston ammeter for this purpose, so that the current desired would flow through the fuse, when the circuit was completed by the traveler on the trackway. The different size fuse wires were subject to the following limitations: The time of the traveler running full length on the trackway, 1.5 seconds; the current ranging from 20 to 130 amperes in 10 ampere steps. The smaller fuse wires would fuse with the minimum

current of 20 amperes, and in all instances inside of the 1.5 arc limit. Consequently, the curves show a wide range, but in the larger size wires a greater current was required to fuse the wires in the 1.5 second limitation, consequently the curves given for the larger fuse wires show less and less range as the fuse wires increase in size.

In order to strike an average, the tests were repeated under similar conditions as regards current and gauge wire, with a 3-inch horizontal fuse, a 6-inch vertical fuse, both of which were connected to a standard form of fuse block, also  $4\frac{1}{2}$ -inch fuse, the average in length of the

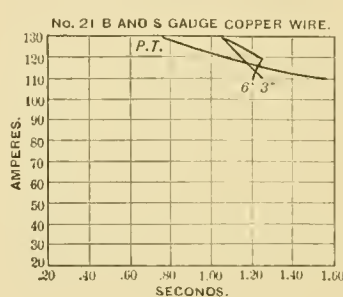

No. 1

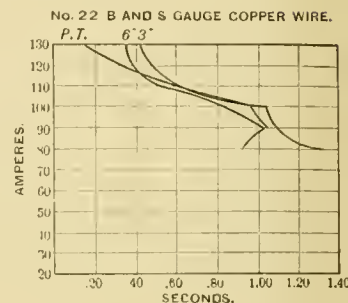

No. 2

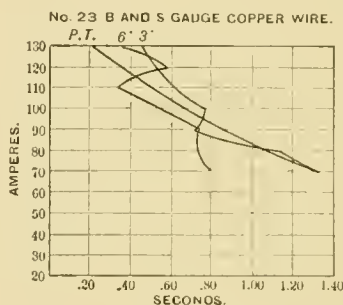

No. 3

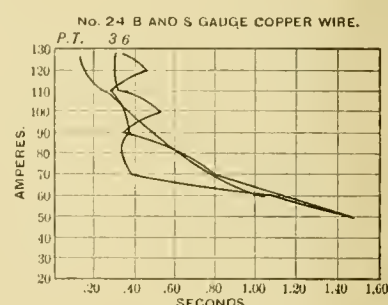

No. 4

3-inch and 6-inch was employed connected in a specially constructed fuse block, which absolutely prevented any arcing of the terminals. In other words, the fusing of the fuse wire could not burn the terminals to which it was attached. The results recorded graphically in the following charts give, therefore, the time required in fractions of a second for the circuit to be opened under identically similar conditions as regards current and gauge of wire for a 3-inch, a 6-inch unprotected and a  $4\frac{1}{2}$ -inch protected terminal fuse.

The curves, as given in chart No. 8 for No. 28 B. & S. copper wire, illustrate excellently the erratic character of the fusing of wires under conditions as observed in the practice of to-day.

The time required to open a protected terminal fuse wire becomes less and less as current increases and grows less regularly, showing that a regular law is followed. The curve is an hyperbola having its asymptotes for its axes, and the equation for it is  $xy=13$  for No. 28 copper. Whereas, the two unprotected terminal fuses are uncertain and show in a very pronounced manner wherein the terminals contribute to this end. The conclusion one is forced to draw is that a fuse wire in practice, when it fuses, does not do as it was intended to, open the circuit, but establishes a condition, though the time may be limited, wherein the terminals act as a magazine to furnish the gas through which the circuit is continued. The curves throughout do not show any superiority of the 6-inch fuse over the 3-inch. Looking at the results in comparison, as given by the Board of Fire Underwriters, which is attached to this paper, the very point they should have observed is overlooked, to-wit, the continuance of the arc through but a short period of time, at the expense of the terminals, and the possibility of the vicious gas thus generated coming in contact with other circuits and establishing other and more serious conditions, such as short circuits and possible fires.

Not to be misunderstood, while the tests as are herein recorded show no superiority of the 6-inch unprotected terminal fuse wire over the 3-inch unprotected terminal fuse wire, the 6-inch fuse wire is unquestionably safer when conditions are more extreme, such as, for instance, when a short circuit occurs.

The determining factor in this matter of fuses is; What are the conditions required to protect against absolute short circuits across the bus



bars of a large power station 500-volt switchboard? Tests conducted showing how fuses act under conditions that are predetermined, certain currents which are made to flow, etc., but you never see anything published or advice given in this matter of fuses for the condition which really occurs the most frequently, that is, absolute short circuits. The Board of Fire Underwriters' report, herewith attached, gives the different length fuse blocks required for 10 amperes, 20, 30, 40, and so on. Now, the requirements and limitations, as prescribed in the Board of

The conclusions one is forced to draw from the above tests and the general literature upon the subject of fuses, are as follows:

First.—The proper and only fuse block to be used is one having protected terminals.

Second.—The fuse blocks should be furnished so that the terminals would not be burned under conditions approaching an absolute short circuit across the bus bars of a 500-volt power station.

Third.—That magnetic cut-outs are immeasurably preferable under all circumstances.

## APPENDIX.

### REPORT OF UNDERWRITERS' INTERNATIONAL ELECTRIC ASSOCIATION.

#### DATA.

The following data gives the maximum length between terminals at which arcing occurs, the minimum lengths at which no arcing was observed, and the safe lengths on 500-volt circuits for fuses, whose melting points are identical with the various current strengths designated.

Amperes.	Maximum length at which arcing occurred.	Maximum length at which no arc was observed	Safe lengths.
10	1/4 inch	1/2 inch	1 inch
20	1/2 "	3/4 "	2 "
30	2 "	2 "	2 3/4 "
40	2 "	2 1/4 "	3 3/8 "
50	2 1/4 "	2 1/2 "	3 1/2 "
60	3 "	3 1/4 "	3 3/4 "
70	3 "	3 1/4 "	4 "
80	3 1/4 "	3 1/2 "	4 1/8 "
90	3 1/2 "	3 3/4 "	4 3/8 "
100	3 3/4 "	4 "	4 1/2 "

### "THE USE OF THE BOOSTER ON ELECTRIC RAILWAY CIRCUITS."

A Special Paper Read Before the American Street Railway Association by J. H. Vail and S. H. Wynkoop.

#### THE AMERICAN STREET RAILWAY ASSOCIATION,

Gentlemen:—The question of investment in copper is one which has always been a bug-bear to the street railway manager, and is to-day the most serious problem confronting the operating company, inasmuch as it tends to restrict the extension of long distance lines for serving suburban traffic. Since the cost of copper for a given service increases directly as the square of the distance, the necessary investment becomes prohibitory when the line extends more than three or four miles from the station.

Railway generators and motors are becoming more satisfactory; we are still allowed, in the absence of a conduit system inspiring confidence, to suspend our trolley wires overhead; and in some cities the authorities will look the other way while we string cables as large as hawsers from pole to pole, in pairs, in dozens, and—if poles could be found to stand the strain—probably in scores.

Even then we are not happy. The power house site is usually chosen, so far as circumstances will permit, with reference to convenient coal delivery and the distribution of traffic. In the heart of the city crowded streets render slow speed imperative; in the suburbs, where a clear track invites to rapid transit, the pressure is low—usually abominably so. In fact, the writers have in mind a city not far from the metropolis, where two motor cars are run upon a single car's time; and they have witnessed the fading out of the electric headlights as the two cars started out together. The reduced voltage was in this case self-evident; and the net horse power secured to move the cars was probably less than half the proportionate amount originally generated in the station. The loss in transmission does not require further demonstration.

Accurate tests show that the commercial efficiency of the street-railway motor at normal voltage is 78 per cent, while at two thirds the normal it is only 52 per cent. We all undoubtedly recognize the fact that the resultant effects of too little copper show up to the non-expert traveling public in slow speed and dimming of lamps; but to the railway company the results are actual losses—decreased traffic and increased coal bill; which is the direct opposite of what we desire. In other words, instead of aiming at the greatest receipts for the least expenditure, we are actually getting least receipts for greatest expenditure.

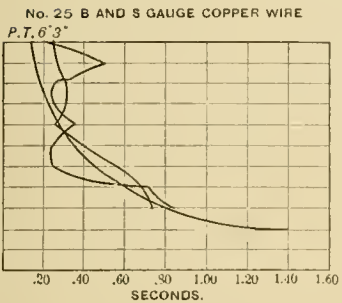

No. 5

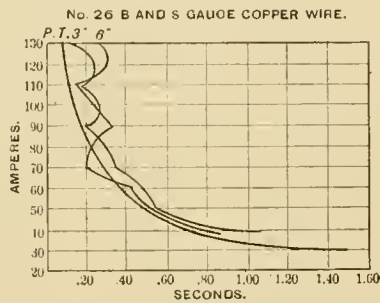

No. 6

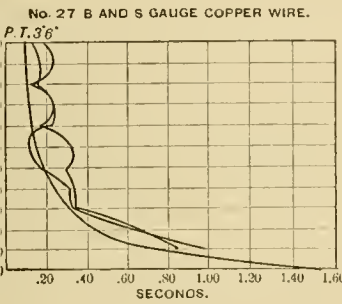

No. 7

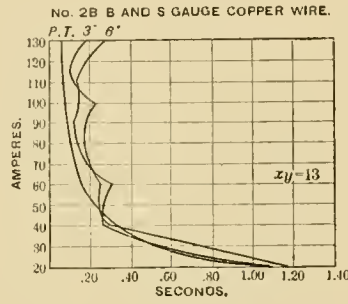

No. 8

Fire Underwriters' report, are true and perfectly safe when the fuse "blows" under the conditions as outlined in the tests, as made by the committee appointed to make such tests.

But on an absolute short circuit across bus bars, as above stated, a 10 ampere fuse block constructed as specified, will, instead of protecting one when most in need of such protection, burn up in the most vicious way, and will open magnetic cut-outs in a power station requiring currents up to a 1,000 ampere to open. Understand, the fuse does not itself do this, but the arc established at the expense of the terminals, is the immediate and sole cause, and the circuit must be opened elsewhere. As stated, the magnetic cut-outs, above referred to, open the circuit.

This matter of arbitrarily adopting a series of fixed dimensions and

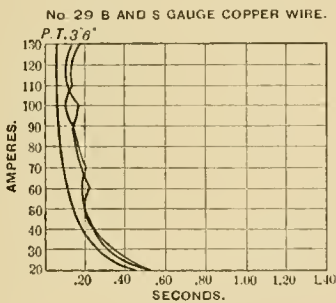

No. 9

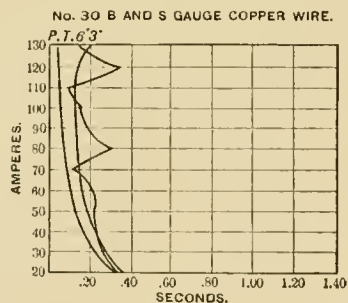

No. 10

conditions, under which fuses are to be used, is absurd and is very similar to a case which came up on the railway with which I am connected.

A man came to the president with a car fender, which he was anxious to have adopted. After expatiating for some time upon its merits, it finally came out that under certain conditions the fender was really good, and if a person should fall in one particular way the fender would surely save him; and he promised to send printed instructions with each fender, so that the people could be instructed to fall properly.

The general remedy suggested is: use more copper. Very good. But if the owners of the road are already groaning under the weight of the copper mine that has been saddled upon them, together with the cash invested therein; if they live in constant fear that they will be forced to place all feed wires in large cities underground, what then?

Leaving out of this discussion improvement in generating station, car equipment and track, we must look for higher economy to the alteration of our methods of electrical distribution, adopting such as will prove, after careful comparison, to be of least first cost, of reasonably high commercial efficiency, of interchangeability on different divisions of the system, and of practically automatic action.

We are in need of a marked advance over present practice in this direction, and must devise some method of distribution that shall give better and more economical service over a large area, and which shall at the same time enable us to reach out from the power station to distances at present inaccessible.

The alternating current system, which has done so much to develop the distribution of electricity for lighting by incandescence, has not yet reached that stage of eminent perfection in motive power service which will warrant us in admitting its value for railway work at the present time.

Another method which might be suggested is one which contemplates the use of motor generators located at intervals along the line and actuated by high tension currents. Such a system must be automatic under all conditions of load and short circuits, working with cool bearings and not requiring careful attendance. This scheme also requires practical development.

The well-known booster system, invented by W. S. Barstow, and applied by him with great success to the feeders of constant potential electric lighting plants covering large areas, is worthy of our careful investigation, as it promises to offer a practical aid to the economic solution of what may be called the medium long distance electric railway problem.

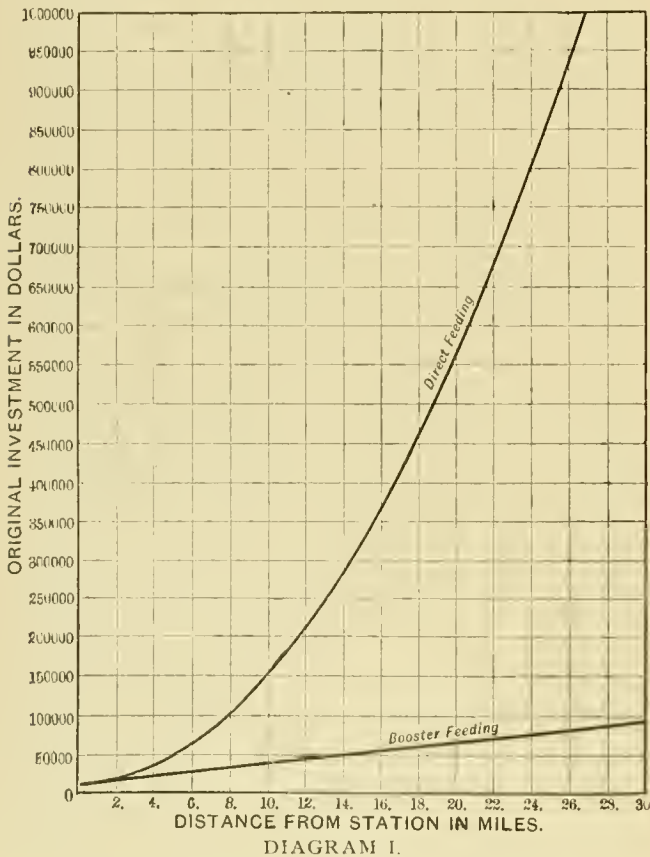

Initial Cost of Steam and Generating Plant, Copper and Special Apparatus for Delivering 200 Amperes at 500 Volts.

With direct feeding we can overcome the loss in transmitting energy only by incurring the heavy cost of copper as a first investment. With the booster system, we overcome the loss in transmission by incurring the cost of operation of a machine which shall automatically raise the initial voltage above that of the bus bars by an amount which may exactly equal the drop in potential on the feeder at that instant.

When using this machine, we calculate our feeder for ampere capacity only, and constantly maintain the pressure at the service end of the feeder equal to the pressure at the bus bars, irrespective of the length of the feeder or the load.

In any given instance, the cost of a direct feeder increases as the square of the distance, while the cost of the booster feeder is directly proportional to the number of miles. These characteristics of the latter system result in a reduction of first cost of from 25 to 75 per cent as compared with the first cost of the ordinary direct feeding methods of our present practice; and it thereby becomes possible for numerous electric street railway companies to extend their lines into suburban localities from ten to twenty miles distant from the power station, at the same time retaining the investment within reasonable limits.

In order to present these matters in a manner easily comprehensible, we can readily establish equations for the two systems to be compared; and then, by assuming certain accepted values, plot the results. Let

- C<sub>1</sub>—Current delivered to trolley wire.
- V — Voltage at generator.
- V<sub>1</sub>—Voltage at trolley wire.
- V<sub>2</sub>—Voltage of booster.
- E<sub>g</sub>—Efficiency of generating apparatus.
- E<sub>b</sub>—Efficiency of booster.
- E<sub>1</sub>—Operating expenses for direct feeding—coal, oil, water, waste, engineers, firemen, and interest on so much of the steam generating and transmission plant as is due to the feeder under consideration.
- E<sub>2</sub>—Operating expenses for booster feeding—details as before.
- M —Length of feeder in miles.
- m —Circular milage of feeder.
- \$ —Initial cost of as much of the steam generating and transmission plant as is due to the feeder under consideration.
- I —Per cent interest on investment.
- D —Per cent depreciation on investment.
- s —Cost of steam plant per H. P.
- g —Cost of generating plant per K. W.
- b —Cost of booster per K. W. output.
- k —Cost of insulated wire per lb.
- p —Cost of placing 544 ft. No. 0000 wire, including insulators, pins, cross arms, sundry hardware and labor—5 per cent allowance for sag.
- z —Cost of supplying one H. P. per year, in quantities of over 100 H. P.

Then for direct feeding

$$\$ = \frac{C_1 V_1}{746} + \frac{C_1 (V - V_1)}{746} S + \left\{ \frac{C_1 V_1}{1000} + \frac{C_1 (V - V_1)}{1000} \right\} g + \frac{2315.488 M^2 C}{V - V_1} K + \frac{.5664 M^2 C}{V - V_1} p \quad (I.)$$

And for booster feeding

$$\$ = \frac{C_1 V_1}{746} + \frac{C_1 (V - V_1)}{746} + \frac{C_1 V_2}{746 E_b} S + \left\{ \frac{C_1 V_1}{1000} + \frac{C_1 (V - V_1)}{1000} + \frac{C_1 V_2}{1000 E_b} \right\} g + \frac{C_1 V_2}{1000} b + 0.19318 m M k + \frac{m M}{211600} p \quad (II.)$$

Substitute the following values in Eq. I.:

- C — 200
- V — 500
- V<sub>1</sub> — 550
- S — 45
- E<sub>g</sub> — .95
- g — 25
- k — .13
- p — 75

We have

$$\$ = 9735 + 1374M^2 \quad (III.)$$

Substitute the same values in Eq. II assuming 211,600 as the value of m, taking E<sub>b</sub>— .90, and finding an expression for V<sub>2</sub> in terms of M, we get

$$\$ = 8732 + 2857 M \quad (IV.)$$

In order to graphically represent the relation between initial investments in the two methods of feeding under discussion, Eq. I. and II. have been solved for varying values of M from 1 to 30, and the results

plotted on Diagram I. An inspection of this diagram shows at once the immense superiority of the booster system over direct feeding in cases where first cost is the essential feature. It will be noted that the curves have been carried out for the entire thirty miles, without regard to the practical voltage limit in direct current machines, or the point at which the cost of operating an independent station becomes less than operating from the main station.

Diagram I shows that for distances greater than one and one-half miles it will cost less to install a booster system than to place copper and machinery in the usual manner for feeding direct. In cases where motive power is water, costing little or nothing per H. P., these curves give at once the relative economy of the two methods; but ordinarily on account of the consumption of coal, the loss in the line (represented in the new method by the power required to operate the booster) becomes an important factor in the discussion; and it is necessary to establish equations for the operating expenses, taking into account the fixed charges of interest and depreciation on the investment, as well as the cost of furnishing the required power.

The following equations will enable us to determine these values for different distances:

Direct feeding:

$$E = \frac{C_1 V_1}{746} + \frac{C_1 (V - V_1)}{746} z + \$(I + D) \quad (V.)$$

$$E = \frac{C_1 V_1}{746} + \frac{C_1 (V - V_1)}{746} + \frac{C_1 V_2}{Eb} z + \$(I + D) \quad (VI.)$$

Making the same substitutions in Eq. V. and VI. as were made in I. and II, placing  $(I+D) = .10$ , and remembering that  $\$$  varies according to the method and distance under discussion, we get

$$E' = 155z + \frac{\$}{10} \quad (VII.)$$

$$E'' = (139 + 36M)z + \frac{\$}{10} \quad (VIII.)$$

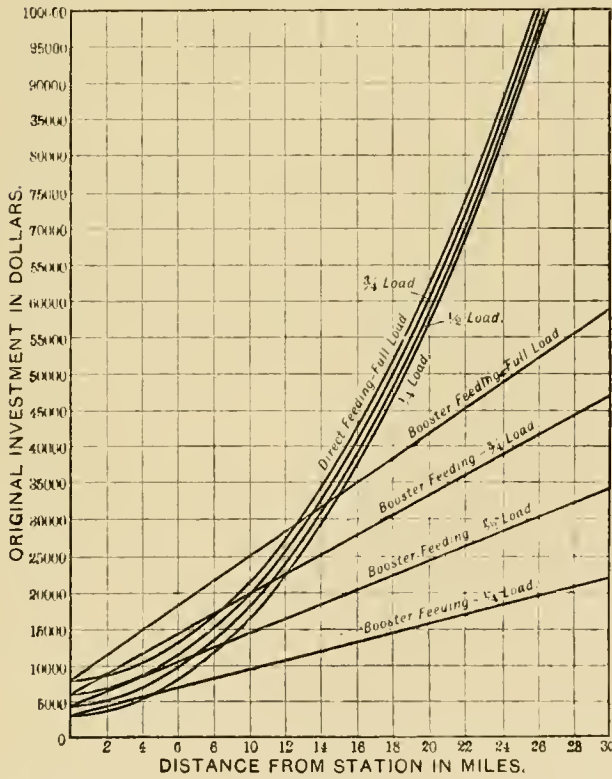

DIAGRAM II.

Operating Expenses of Plant Delivering 200 Amperes at 500 Volts, Including Coal, Oil, Waste, Water, Labor; and Interest and Depreciation on the Investment.

Diagram II. represents these equations plotted for varying values of M, being taken at 40.

The intersection of the upper curve with the upper straight line is the point at which the booster system costs as much to operate as does the direct system. This distance we find to be twelve and one-half miles. For shorter distances, direct feeding is more economical, while for longer distances the booster system has an absolute advantage. Now, the assumption upon which Eq. V and VI were solved, is a feeder constantly loaded to its maximum capacity. The absurdity of this assumption is apparent when one considers the actual conditions which obtain in railway work; the average load on the feeder during the entire year will be more nearly one-third or one quarter of the maximum. We have therefore established and plotted equations similar to V and VI, for  $\frac{3}{4}$ ,  $\frac{1}{2}$  and  $\frac{1}{4}$  load, and the resultant curves are shown on Diagram II, in order to afford ready means of comparison.

A careful study of these diagrams demonstrates in what the economy of the booster system consists. While the method we have outlined may seem like robbing Peter to pay Paul, it must be remembered that in direct feeding there is a large amount of capital invested in the pole line, accruing interest day and night, in storm and sunshine, irrespective of the traffic on the line; while with booster feeding, the interest on copper investment is nominal, the power required to drive the booster itself being proportional to the load on the line. Thus we can readily understand why, under the conditions given, with an average load of one-quarter the maximum, the booster system is absolutely more economical than the direct feeding system for distances over four and one half miles.

The equations here laid down will serve to answer any questions that may arise as to relative first cost or operating expense. It has been impossible to represent results derived under varying conditions without multiplying the diagrams indefinitely. All calculations have been based upon the most recent methods of rail bonding and track feeding; and the assumption that the resistance of the return circuit is equal to that of the outgoing circuit is therefore perfectly safe.

It may occur to some that the installation of a special high voltage generator to supply the feeder in question would be a simpler method of reducing the copper; but a cognizance of the enormous variations in drop under extreme changes in load, on a long feeder calculated for ampere capacity only, leads at once to the discarding of such a scheme until such time as manufacturers can furnish efficient generators over-compounded from 50 to 150 per cent.

The adaptability of the booster to railway work of all kinds is wonderful. A few specific instances are noted, in the confident belief that the suggestions thus thrown out will impel each and every electric railway manager to personally investigate this system, with a view to ascertaining exactly how far it would prove of advantage when applied to his particular road.

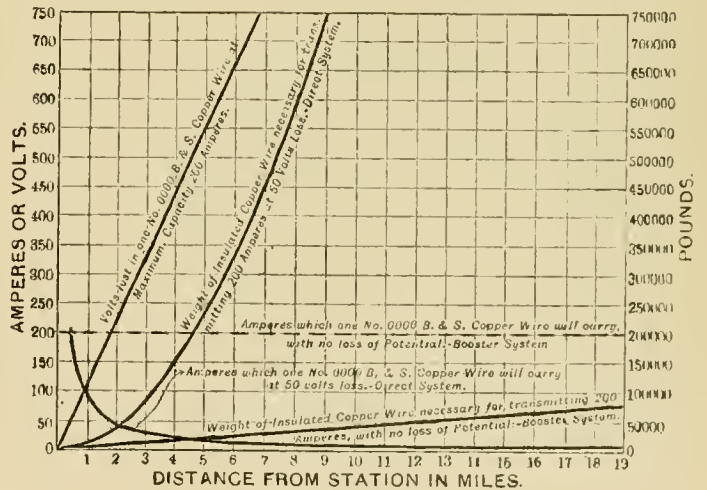

DIAGRAM III.

Comparison between Direct and Booster Feeding for Railways. Resistance of Return Circuit (Rails)=Resistance of Feeder. Allowance for weight of Insulation=15%. Allowance for Sag=5%. Show the Investment Saved in Weight of Copper by Means of the Booster System.

Ordinarily in calculating copper for distribution we are obliged to allow for special features influencing traffic, such, as ball grounds, race tracks, picnic groves, etc. As there is seldom any necessity for bunching cars at all these points simultaneously, and as the various features are usually

scattered, it follows that at all times one or more of the feeders is lying comparatively idle. Under the plan suggested, the copper is figured for average conditions and a booster, placed in the station, is arranged to be thrown immediately upon any feeder which may become burdened with an excessive load.

Another feature of this system which makes for economy becomes prominent on long suburban lines forced to run an infrequent schedule late at night. On such a road the booster may be shut down and cut out of circuit entirely when the load on the long distance feeder drops to say one quarter of the maximum, depending upon the amount of copper in the line.

If this suburban line extends to a park or pavilion which is open only during the summer months, the advantage of the booster over direct feeding is enormous, since the investment on a booster lying idle is a small fractional part of the interest on the idle copper of a direct feeder.

On many roads already in operation the copper in the line has proven entirely insufficient, and the erection of additional feeders is contemplated. Would it not be worth while to consider the installation of a booster at one-tenth the cost of the extra copper, provided calculations showed the economy of operating the two systems to be equal?

In the progress of electric railways, as in the growth of cities, development frequently fails to follow the lines predicted for it. It therefore happens that many a road to-day is worrying along, the victim of misplaced judgment—and copper. In many instances the adoption of a booster, and a re-distribution of the present copper, will remedy the evil in the most economical manner.

In large cities such as Boston, Brooklyn and Philadelphia the tons of copper could in this way be largely reduced, with a gain at the same time in uniformity of pressure.

## TAXATION.

Special Paper Read by Allen Ripley Foote, of Washington, D. C.,  
before the American Street Railway Association.

The following paper on the subject of Taxation is respectfully submitted for your earnest and thoughtful consideration.

It is subdivided as follows:

1. Taxes: Why are they paid?
2. Taxes: Why and how is payment evaded?
3. Taxes: By whom should they be paid?
4. Taxes:—How can a just system be established?

### TAXES—WHY ARE THEY PAID?

1. One of the fundamental objects of government is to establish justice. This function of government is the only one considered in this discussion. Justice is established by securing obedience to just laws. Injustice is done only when the rights of one are invaded by another. Law and enforced obedience to it, when such course is necessary, is the protection given to each to secure him against an invasion of his rights by others. The cost of this protection measures the amount required for the support of the government in its effort to establish justice. To secure this protection taxes are paid.

2. Protection is most needed by the weakest member of society. A government that fails to make protection certain for the life and property of its weakest member invariably becomes a tyranny and forfeits its right to exist. Failure to punish a crime gives protection to wrong doing. The punishment of crime gives protection to right doing. The whole expense of enforcing obedience to law is caused by those who disobey law. This is the direct burden paid by taxation.

3. The indirect burden caused by disobedience to law is far greater than the direct burden. If it could be made certain that no law would be disobeyed the tremendous burdens laid on industry for the enforcement of obedience to law, and the still greater cost, borne in a thousand ways, by individuals, families, firms, companies, corporations, and associations, to secure themselves against the injustice of others, would cease to be a tax on the energies and thrift of honest people. If absolute justice could be done the entire amount of the direct tax and the indirect burden levied upon society by law-breakers would be exacted from the criminals. This is an impossibility. Taxes can be paid only by assessments upon property. The combined property of law-breakers would not be sufficient to pay more than an extremely small fraction of the total cost to society of their conduct.

4. The natural law of justice is the only true standard of conduct. This law existed before governments were created. Had it never been disobeyed, enacted law to enforce obedience would never have

been necessary. The fundamental necessity for organizing governments was to enforce obedience to law. Every principle of enacted laws and of regulations for giving them practical effect must be aligned with the principles of natural justice if justice is to be established among men. When this is done the principles of enacted laws ring true through the ages and stand unchanged in the laws of all nations having sufficient intelligence to desire to promote the individual and public welfare of all men. So stand the laws:

"Thou shalt not kill."

"Thou shalt not steal."

5. Justice is established through obeying just laws. The laws of themselves can do nothing. They are simply rules for the guidance of conduct. Through right conduct only is justice done. In seeking to establish justice the first duty is to see that enacted laws are just and then to see that they are obeyed. Voluntary obedience of laws is the act of a free man responding to the dictates of his own conscience. Such obedience to its full extent relieves society from all expense for the enforcement of law and thus lightens the burdens of taxation.

6. Involuntary obedience to laws may be secured to a large extent through the coercion of many persons by public opinion. Such obedience also reduces the expense for enforcing laws. This saving may be designated as an increment of value developed by the presence of a large number of law-obeying persons in a community.

7. Enforced obedience of laws is secured through the certainty of detection and punishment for disobedience. This entails on society all of the direct and indirect expense of securing protection against evil-doers. This tax must be paid or there will be no security for life or property. This fact is quickly apparent when it occurs, through a combination of circumstances, that public authorities are temporarily deprived of the power to enforce obedience to laws. Instantly all the evil in men is liberated for a high carnival of crime. The desire to commit acts of violence draws all of like disposition to a central point of disturbance and the rights of life and property are invaded with fiery enthusiasm. An object lesson illustrating the value of the protection secured for life and property through the enforcement of laws has recently been given by the riots in the West. The cost of these riots shows how infinitely cheaper it is to pay the cost of an efficient government than to suffer the damages caused by a suspension of the enforcement of laws.

8. The lesson taught by all experience is plain. Considered only as a matter practical of business, it is less expensive and much more satisfactory so to educate each person, as far as it possibly can be done, as to cause him to voluntarily obey just laws, than to spend money for punishing transgressions of laws. The benefit of securing obedience in this way is cumulative through its effect on those who are influenced to right doing, with as much certainty as they are influenced to wrong doing, by the character of their environments. Riots destroy more value in a few days than would be sufficient to pay for many years of educational work. It is very much cheaper to spend money for the purpose of training political action to secure the enactment of just laws than it is to fight the effects of unjust laws. The cost of business panics and industrial disturbances emphasize the sound business policy of such use of funds, and yet, so-called practical men will do little or nothing in this direction, being apparently unable to grasp the fact that they are but incidents controlled by overruling forces and pay they must, either for the proper economic education of the masses, or for the destruction, disturbances, and uncertainties caused through lack of such education.

9. That present conditions present a most favorable opportunity for seeking a reduction of direct taxation and indirect burdens through well considered and well sustained economic educational work is shown by the following news items:

BUFFALO, N. Y., Sept. 9, 1894.—J. W. Sovereign, General Master Workman, Knights of Labor, said: "Generally speaking, nothing more than a temporary victory can possibly be achieved by strikes at best. They widen the breach between capital and labor, and no matter which side is worsted, it is sore over its defeat and will retaliate with vengeance at its first opportunity. All strikes are illegal and all strikers are criminals. We cannot hope to accomplish much by strikes. It is in study and education and the wise use of the power that is placed in their hands through the ballot that workmen must hope for relief from the conditions of which they justly complain." —*New York Herald*, Sept. 10, 1894.

(Continued on page 645.)



*This department is devoted to the construction and operation of electric railway power houses. Correspondence from practical men is specially invited. Both the users and makers of power house appliances, are expected to give their views and experiences on subjects within the range of the department.*

EVERY month come reports of the serious crippling or entire shutting down of stations where the beautiful and efficient (?) line shaft is still in use. One time it is a broken shaft, at another it is a cracked pulley, and again it is a wrecked clutch or a hot box.

\*\*\*

ONE of the most frequent causes of shutdowns of large stations is a failure of the water supply. In arranging a plant it is often forgotten that the city water supply of no city is infallible. A reserve tank large enough to be of any value is not always easily found room for in crowded city plants, but where there is no provision made the company must expect to suffer the consequences.

\*\*\*

EVERY engineer of a small plant knows how trying a job it is to stand and pour a fine stream of oil from a wide necked cylinder oil can into the small orifice usually provided for that purpose in the ordinary cylinder lubricator. Don't do it any more, but put up a cup large enough to fill the lubricator, so that by simply opening a valve its contents can be emptied into the lubricator. It saves bad words.

\*\*\*

THERE is a promising, though as yet unoccupied field, for the use of electric motors, to take the place of the small steam engines around a railway power plant. Electric motors are now running the mechanical stokers in an electric station at Liverpool, England, and it will probably be only a question of time until they are extensively used for other station work. There are many plants in this country that are using small steam engines for several purposes. The first use that suggests itself for the electric motor in this connection is for the boiler feed pump. An objection appears at once to the average engineer, that the pump can only be run while the generators are running. That is very true, but two pumps are installed in every good station to provide against breakdowns, and one of them could be electric and one steam. The electric pump could be run the greater part of the time and the steam pump kept for emergencies and times when no

generators are running. The steam feed pump of the ordinary direct acting type is a notoriously inefficient apparatus, both on account of condensation and because it makes no use of the expansion of the steam. The electric pump ought to at least make as good a record as the steam, as to efficiency, while running with much less attention and repairs. If properly wound, the speed of the electric pump can be varied without interfering seriously with its efficiency. Any engineer of experience knows that the average steam feed pump needs a good deal of attention in proportion to the work it performs, and when it is run slow, as is often the case, there is a great deal of condensation of steam and leakage of both steam and water. If mechanical stokers are used, another field is open for the motor, as is also the case with mechanical draft created by fans in the stack, and ash and coal conveyors. In all of these places the reserve can be the usual small steam engine, so there is no increased danger of a shutdown.

\*\*\*

THE number of power house engineers who get a "rake off" for recommending to their confiding employers the apparatus and supplies to be used, is said to be very large, but it is probably smaller in the street railway business than in any other, because the engineers are of a better class and the business is so largely a mechanical one that the owners and superior officers understand the details of power house work too well to have the wool pulled over their eyes. It usually happens that those who are caught this way are those who most deserve it. If those who control the financial interests of a road have no more common sense than to hire cheap labor, which is the most open to bribery, and then place all their dependence on it, they ought to suffer for it, and they generally do, if not in the way mentioned, in some other. The competent engineer is usually honest, and there are plenty such to be had, so that there is no excuse for employing men with aldermanic tendencies.

\*\*\*

It would be of value to know whether there is as much loss in practice as is commonly thought when the smoke is not consumed. Smoke sometimes indicates poor combustion and consequent loss of fuel, but it has not been conclusively shown that smoke consuming devices, taken as a class, increase the efficiency of a boiler plant to any extent. The majority of such devices

necessitate a slower combustion, and hence a reduced steaming capacity of the boiler in question or else increase its heating surface without increasing its steaming capacity, which amounts to the same thing. It seems to be impossible to burn all the smoke when a boiler is being forced. One of the simplest devices for securing perfect combustion is one that has been put in by Edward Saxe, chief engineer of the C. B. & Q. building in this city. The boilers are common return tubular, and the bridge wall is brought clear up to the shell of the boiler and perforated with holes several inches square for the flames to pass through. The fire doors swing up from the bottom and are kept slightly open so that a sheet of air passes over the fire. With the ordinary bridge wall this would be fatal to economy, but with the divided wall the air passing over the fire is made to thoroughly mix with the unconsumed gases coming off of the fire and to make a perfect combustion. The harder the boilers are being worked, the more air is admitted over the fire. Only a light smoke is given off from the chimney and the boiler efficiency is good. R. R. Tatlock, in the Chemical News, cites some experiments of his which show that not over 15 per cent of the heat in a fuel is lost in smoke, and as a rule much less. He thinks that there is little or no gain in burning smoke.

\* \* \*

It has been a well known fact that lowering the voltage on a railway system will sometimes cause a great increase in current; which fact is made manifest by a continual opening of circuit breakers and blowing of car fuses. Nearly every power house man of long experience has either had or heard of cases of this kind. Two excellent examples of this recently came under the writer's notice. In one case the traffic on a road was unusually heavy on account of a special celebration, and one and two heavily loaded trailers were being hauled by the majority of the motors. Fuses on the cars were being blown frequently. Word was telephoned to the power station and the engineer raised the voltage, with the result that the trouble ceased. The other case was in a small power station running three 90-kilowatt generators. The chief engineer being absent, an attendant had charge, who was afraid of overdoing things and kept the voltage low. Forthwith trouble began from belts coming off, and this continued until the chief came back. He immediately saw the cause of the trouble, which disappeared when the voltage was raised. The average electrician, when asked the reason for an increase in current when the voltage is let down, will thoughtlessly answer that it is because a certain amount of energy is required to do the work, and if the volts are decreased the amperes must increase as energy is measured in volts times amperes. It is manifest that this does not explain the matter, for if it did, more current would flow through a given resistance with the pressure at 300 volts than at 500 volts, and we know very well that the reverse is true. The real explanation must be that when the pressure is low an immense amount of energy is wasted before a car begins

to move with a heavy load. It happens in this way. Suppose a car to have its resistance so arranged as to give an easy start to the car running alone under ordinary conditions with the voltage at 450 to 500. This is the usual adjustment. The motorman puts the controller on the first notch and the car moves off. The motorman becomes taught by his experience that the car will start on the first point. He is also taught by his instructors that he must pause after each point. Suppose now the voltage be lowered from one of many possible causes. Suppose also for example that 60 amperes is required to start the car. When the voltage was high the resistance on the first point was such that 60 amperes immediately flowed and the car moved off so that the current was soon brought down to 25 or 30 amperes. But if the voltage is lowered the current that flows on the first point may be only 40 or 50 amperes, and the necessary 60 amperes may not flow until the third or fourth point has been reached. Meanwhile the motorman is moving the controller from one point to another, and pausing after each point, so that quite an interval occurs before the car starts. During all this interval a heavy current is flowing, which, although falling short of that necessary to move the car, causes a much heavier drain on the station than if the current jumped up immediately to the required point and then was soon reduced by the counter electro-motive force of the moving motors. When trailers are hauled this waste of current before the car starts is likely to be even greater. Motormen should be taught to lose no time with the controller until the car begins to move. On some roads this is taught. On others it is not, but ought to be. Another reason which causes an increase of current on some roads when the voltage is lowered, is that it cuts down the car speed. In order to make schedule time the motormen are obliged to have the current on the motors a greater per cent of the time, and thus several cars on a system are drawing current when under ordinary conditions they would be coasting or lying over at the ends of routes. Still another reason is the lower efficiency of the motors when the voltage is below normal.

#### NORTH SHORE ELECTRIC LEASE.

The Chicago North Shore Street Railway Company has demonstrated itself a financial success, having earned the interest on the bonds, besides a fair dividend, which is remarkable, considering that the \$650,000 of capital stock is entirely water, the proceeds of the bonds having built the road. So promising is the future of the new road that the shrewd managers of the North Chicago Street Railroad Company are trying to secure a permanent lease of it. As a consideration for such a lease, the latter company offers to guarantee a dividend of 6 per cent and the interest on the bonds. As the new road is virtually an extension of the other, the proposed lease would be a mutual benefit. The road has to all practical intents been operated as a part of the north side system for some time.

## LESSONS FROM TERRE HAUTE.

The track construction of the Terre Haute Electric Railway has long had a national reputation, and within the past few months other features of this road recently inaugurated by its new president, Russell B. Harrison, have attracted so much attention that the system was deemed worthy of a personal inspection by one of the REVIEW staff. He was not disappointed in his search for ideas of value and interest to other street railway men.

He found the service excellent as to frequency and speed. Employes, both conductors and motormen are well trained to their respective duties. The rolling stock is being rapidly brought up to a high standard and the motor equipments are the greater part of them of the latest Westinghouse type. For a road electrically equipped several years ago this is a splendid showing.

The first thing to attract attention was, of course, the magnificent system of paving used in connection with the T rail, which rail is used exclusively. The T rail is used with success in dozens of other small cities of this country, but a surprise is in store for those who think they have exhausted the subject of paving to T rail before they have visited Terre Haute. As far as track work and paving are concerned, it is safe to say that Terre Haute has the most beautiful street railway streets in the world. Wabash avenue, the main street, is paved with brick from curb to curb. The street railway track is double on this street, and is of 60-pound Shanghai T rail. The ties and paving rests on seven inches of concrete. The paving and track have been down three years. The paving is as smooth as a floor, and the rail joints are scarcely perceptible. On this street, which was one of the first laid, a brick is used which fits up against the web of the rail and leaves a groove for the wheel flanges. On other streets, large hollow corrugated blocks are used along the rail and the filling around the rail web, both inside and out, is cement and pitch. This, too, seems to give very good service, but the management says that the corrugated surfaces wear too fast. There is also one route on which the street is paved with asphalt and the hollow corrugated blocks are laid on each side of each rail. The street presents a beautiful appearance. On none of the streets is the interference with team traffic as great as with a girder rail. It has also

been conclusively shown that where T rail is used, the street traffic does not get in the way of cars as much as with girder. Managers who are struggling with a city council for permission to lay T rail would do well to arrange for an inspection of the work at Terre Haute. Some track is about to be laid with 72-pound rail on the Daniels steel ties (15 inch centers), with new and original brick paving, designed by Mr. Harrison. Mr. Harrison justly prides himself on the fact that this will probably be the finest piece of street railway track in the world. It will be unsurpassed for strength and smoothness. The Illinois Steel Company's Shanghai 72-pound T rail, 6 inches high, is now used on all work, and gives universal satisfaction.



RUSSELL B. HARRISON.

This road has the distinction of being the first to try the new No. 12 Westinghouse motor. The first pair was received last January, and put under a snow plow. Since then the cars in regular service have been equipped with them. It was found to be quite a problem to adapt the spring suspension to the trucks on hand. In fact the company had to work out its own salvation in this regard, as at that time neither the truck makers nor the Westinghouse Company had given the problem of adapting the motor to a particular make of truck much attention. The experience gained on this road has been very valuable to the manufacturers for future work. The Westinghouse new motor is so constructed that it will permit of nothing but the new method of suspension, and that suspension is a peculiar one. It is in effect almost as if the motor was hung from the car floor by a spring attached to the middle of the top of the motor frame. The method adopted for use with the Peckham trucks, with which all are now equipped, is very satisfactory. There have been some fears that spring suspension would cause galloping and surging of the motors, and the writer confesses to have shared in these fears, but after riding many miles over the spring suspended motors as used on this road, and having an opportunity to observe closely what action took place, those fears were proved groundless as far as the Westinghouse



MAIN STREET—TERRE HAUTE, IND.

## Street Railway Review

No. 12 motor is concerned. There can be no doubt but that this suspension is easier on the track and car.

One of the first things to attract the visitor's attention on arriving at Terre Haute, is the peculiar position of the signal bell rope on the cars. The conductor's end, instead of being hitched to the hood, as usual, hangs down and is passed under the hand rail, terminating in a pear shaped handle, about three feet above

The power plant is the work of Westinghouse, Church, Kerr & Company, and is one of the smallest street railway plants in the country using mechanical stokers. There are three horizontal return flue boilers 54 inches by sixteen feet. The saving over hand firing, is unquestionable, as only one man is kept on duty in the boiler room. The ashes are thrown into a dump car of special design and hauled off to ballast the remote



THE "CELEBRATE" TERRE HAUTE RACE TRACK

the platform. The reason for this is soon learned, when it is seen that conductors are required to step off the car to help women and children off and on, and the position of the bell cord, where they can reach it from the ground, saves much time. The plan of building platforms now adopted by the management is to extend the dash so as to have steps only on the right side of the rear platform, and the left side of the front platform. Another change being inaugurated, is to take the slats off the car floor and put down rubber mats. These mats keep all moisture from dripping through on to the motors, besides being more easily cleaned than the slats. They are also much pleasanter to walk on, and give the car a more attractive appearance.

The road is, for its size, remarkably well equipped for doing its own work. In addition to the repair shop, it has a department for building and rebuilding cars, which employs three car carpenters and one car painter. Many cars have been entirely rebuilt, and new trailers are constantly making their appearance. The company will soon commence building closed cars. In the blacksmith shop, which employs two men, the greater part of the special track work, frogs and switches, required by the company is turned out, as well as the ordinary run of rolling stock repairs. The company has a fine and well equipped machine shop, and we were pleased at the extent and character of the work turned out.

parts of the system. A year ago public sentiment was hostile to the street railway, but owing to the progressive policy which has marked "Harrison's Administration," there is now the best of feeling. The employes also uphold the management with enthusiasm, and the laboring people of Terre Haute not only appreciate the change, but are staunch and true friends. On the very evening when the Debs strike was inaugurated, resolutions were passed by the local American Railway Union endorsing the street railway president of Terre Haute, Debs' home.

Some very original ideas in the way of public entertainment and inducing traffic have been launched in the past few months. On the fourth of July horse and bicycle races and games were held on the fair grounds, the contestants being followed by a powerful electric search light run from the railway circuit. The same evening there was also a balloon ascension and parachute drop by search light. On another occasion an electric fountain was fitted up for use in an evening parade. The effect was beautiful and caused much wonder. The fountain was built on a flat car. The tank was lined with tarpaulin and the water kept in motion with an electric pump. All the unsightly part of the car was covered with lights and decorations. The fountains consisted of a perforated circle of lead pipe laid on top of the glass plate, under which the fountain lights were



MOTOR CAR PULLING THE TRAILERS FROM COLLETT PARK



placed. It was lit from the trolley wire and hauled by horses, as were the other floats in the parade.

The enterprise and hustle of the management is well illustrated by the dispatch with which the electrical dis-



play for the Elk's picnic was prepared last fourth of July. A car load of electrical designs was shipped by a special car from the Edison Lamp Works at Newark, N. J. Everything in connection with the display had to be set up specially for the occasion. The fourth was on Wednesday. The alternator for running the lights came at 7 p. m. the previous Sunday. The wire and cross arms for connecting the station with the fair grounds two miles away did not come until Monday noon. In spite of the haste with which things were put up everything was a success and there was no hitch in the display. The set pieces of the electrical fireworks are enumerated as follows: one waving flag 10x12; two large and two small shields; an old Dutch windmill; an eagle's nest; two stars; a cone; two prisms and a peacock. The display cost about \$1,000 and was so well received that it was repeated several nights. The set pieces were rented from the Edison Lamp Works. This fall a number of balloon ascensions have been made by search light.

A great deal of enterprise is being shown in the development of traffic to Collett Park, a beautiful park owned by the city and situated about two and a half miles from the business center. This was until very recently closed by the city at 8 p. m., and it took a good deal of work to get it open in the evenings, as the people had never enjoyed the pleasures of an electric illuminated park. Finally a contract was given to the street railway to light the park at a very low figure, and attractions are now provided by the company every night. A stage has been built and surrounded with seats. The park and stage are brilliantly lighted with arc and incandescent lights. The railway operates a search light, which, as it turns around, illuminates every corner and makes an attractive scene. The entertainment provided is high class, and the park is nightly patronized by the best class of people. Admission to the park and entertainments is free. Two very fine solo cornetists have been employed for several weeks past at a good round figure and have proved a drawing card. In addition to these there is

usually a good variety programme. For example, on one evening recently a colored quartette, two tumblers, a contortionist and a shulle dancer, contributed one or two numbers each.

The company has a very fine band known as the Electric Railway Band, and an orchestra of eighteen pieces known as the Electric Railway Orchestra.

From five to ten thousand people visit the park daily. Everything is done to make the trip attractive. All cars, including trailers, have double the usual number of lights, and it is surprising how much it improves their appearance at night. It is safe to say that the additional lights are about as good an investment as can be made. It is hard to resist the temptation to take a run to the park when the brilliant trains are seen going by. The cars are run on a fast schedule, which makes riding most agreeable and gets the most service out of cars and men. The motor cars each make 120 miles a day.

On leaving Collett Park one evening recently, the REVIEW man was confronted by a train of five trailers and one motor car. The trailers were attached to the motor car and the train was ready to take a part of the rush at the close of the entertainment, a plan here frequently adopted. The train was headed by motor car No. 53, which had a double equipment of Westinghouse



No. 12, 30-horse-power motors. This train, loaded to the sills, moved off on a level track with the controller on the first point. On the way in, a 45 foot radius curve was rounded. In the center of town the train had to stop on a 55 foot radius curve, but was started with the controller on the third point. About 400 people were on the train.

The management is making every effort to make the road a model one, and the effort is being crowned with success. It is well situated in a good business town of 40,000 people. It need hardly be mentioned that the fair grounds, which are reached by the street railway, contain a racing track, the fastest in the world, famous



COMPLICATED SPECIAL WORK—MILWAUKEE.

for its world's records, and what is of more interest to our readers, the great crowds which assemble there, are handled so well that the efficiency of the service is frequently commented on by the press and by all the strangers who visit Terre Haute. The Terre Haute Electric Railway is a model from the standpoint of the public and worthy of the attention of all street railway men. President Harrison and Superintendent Burke are a great team of progressive wide awake hustlers, and under their management the road is being made a most successful one.

#### COMPLICATED SPECIAL WORK AT MILWAUKEE.

The accompanying engraving represents a view looking up Farwell avenue, in Milwaukee, at the intersection of Murray and North avenues. The Farwell avenue car barn is seen at the left. An idea of the amount of work done in designing the curves and crossings can be

obtained from a glance at the plan which shows that there are 24 curves, 30 pairs of tongue switches and mates and two double-track crossings. The narrowness of the street and the small clearance of posts in the car barns complicated matters even more. Superintendent of Construction A. W. Lynn, has long seen the importance of putting in this special work, so as to make the Farwell avenue barn the distributing center for the east side, and he is to be congratulated for at last having his idea carried out and the soundness of his judgment proved. The plans were made by Clement C. Smith, formerly engineer of the Milwaukee Street Railway, and now assistant engineer of track construction on the Chicago City Railway. The special work was all made by the Milwaukee Street Railway. Guards are put on the inside rail only. The guard rail is an old tram rail bolted to a girder rail from which a part of the tram has been cut off. The thick edge of the tram rail forms the guard. Cast iron blocks form the fillers between the tram rail and the web of the girder.

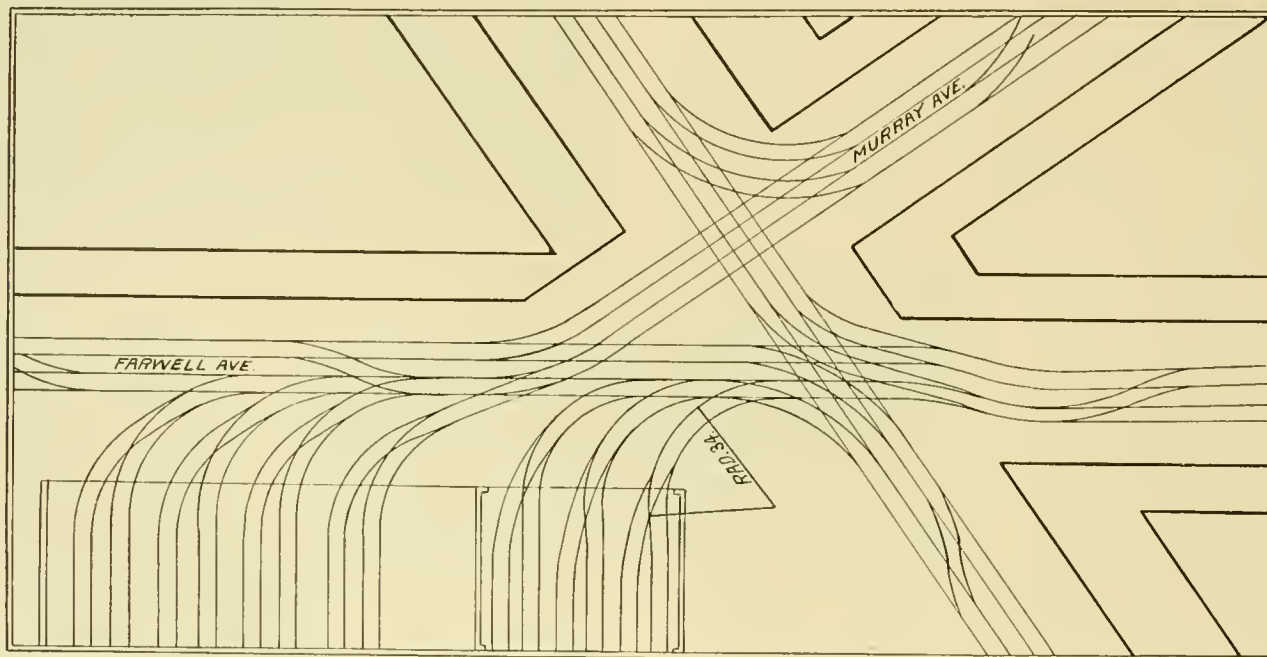

COMPLICATED SPECIAL WORK—MILWAUKEE.



WINDSOR & KENFIELD,

PUBLISHERS AND PROPRIETORS,

269 DEARBORN ST., - - - CHICAGO.

Published on the 15th of each month.

SUBSCRIPTION, - - - TWO DOLLARS.

FOREIGN SUBSCRIPTION, - - - 20 SHILLINGS.

Address all Communications and Remittances to THE STREET RAILWAY REVIEW,  
269 Dearborn Street, Chicago.

H. H. WINDSOR,  
Editor.

F. S. KENFIELD,  
Business Manager.

**CORRESPONDENCE.**

We cordially invite correspondence on all subjects of interest to those engaged in any branch of Street Railway work, and will gratefully appreciate any marked copies of papers or news items our street railway friends may send us, pertaining either to companies or officers. Address:

THE STREET RAILWAY REVIEW

269 Dearborn Street, Chicago

Eastern Office, Room 14, No. 126 Liberty Street, New York.

This paper member Chicago Publishers' Association.

Entered at the Post Office at Chicago as Second Class Matter.

VOL. 4.

OCTOBER 15, 1894.

NO. 10.

It is with great pleasure the REVIEW announces the fact of having added the services of Mr. James Boyd, in a prominent position of its editorial department. Mr. Boyd has held responsible positions for several years as department editor on one of Chicago's leading dailies, and later as managing editor of a prominent trade journal. This latter position he leaves to accept a more lucrative one with the REVIEW. Mr. Boyd is a young man of unusual experience and promise, whose reputation is already made, and we bespeak for him the welcome and exchange of courtesies which has always been so fully tendered the REVIEW staff.

STREET railway shares are now a prominent trading feature on Wall street, and are bound to become more important each year.

THE little interurban, described in this issue, between Tama and Toledo, Iowa, is but a forerunner of hundreds of similar roads that will be built within a few years. We call this a forerunner because it is probably the smallest paying road of its class in the world.

THE absence of strikes on street railway lines during the present year is a commendable and hopeful sign that both employer and employe are coming to understand each other better, and are more strongly united than ever before in the one purpose to promote the good of a common cause.

BETWEEN the interior fittings of the horse car of six years ago and the average electric car of to-day there is almost as much difference as between the two methods of traction. One of the apparently small, though by no means unimportant, differences is in the height of the seat. There are very few fine cars built at present with seats as low as was common on old horse cars. It seems to be the universal decision that the higher seat is preferable. While tastes differ in this regard it is generally true that tall people are more uncomfortable on low seats than short people on high seats, and modern car builders recognize the fact. This is a point that it is well to remember in refitting and improving old cars. The public does not usually stop to reason why street car riding is comfortable or uncomfortable, but it renders its verdict just the same to the profit or detriment of the company. The decision is based on such little details as the one mentioned whether recognized or unrecognized.

IF all the good money that has been wasted on electrical patent litigation in the past five years could be spent in manufacturing and in making new inventions, it would put the companies that have spent it in positions where they would not need to care whether the contested patents were valid or not. It seems strange that some electrical companies cannot perceive what everyone else must, that there are some inventions of such doubtful origin that they can never be permanently located as the property of any one company. After a device or principle has been in use for some time by a large number, it is like flying in the face of fate to try to establish claims to the exclusive control of it by one company, especially if the company in question appears to intend to "put on the screws" when it gets control. Very little of the money spent in electrical patent litigation is anything better than absolutely wasted. The business of electrical companies is in manufacturing, not litigation, but some of them seem to forget it to the detriment of all concerned.

ONE has only to glance at the map of any good agricultural state and note the number of small township centers and villages that are without railroad communication, to be convinced that something will be done to give these communities a better outlet to the rest of the world than a wagon road that is never good and is almost impassable six months of the year. The country is becoming thickly enough settled so that it will not pay to leave its richest agricultural districts so much isolated from the main highways of commerce. America is distinctly a country of railroads, and the factor of distance, which has caused the remarkable growth of steam roads, will make the interurban flourish. The meshes of the steam road network are about as fine as it will pay to make them in many parts of the country, and the rest of the territory must be covered by the electric road. There is hardly enough business as yet in any part of the country to support a road built for "purely agricultural" traffic, but when combined with the interurban there is an abundant field for good investment.

THE convention report, by Richard McCulloch, on mail, express and freight service for electric railways is by far the most thorough treatment the subject has yet received. One point never brought up before, as we believe, is that of carrying express and freight to suburban districts for the sake of increasing the desirability of those districts as places of residence. While the express and freight business may not appear very attractive to managers on account of the extra trouble involved and the smallness of the revenue in proportion to that received from passenger traffic on a city and suburban line, this argument of inducing suburban residence ought to have a good deal of weight. The want of facilities of this kind is no doubt quite an important factor in hindering suburban growth, as many can testify from actual experience, but if express and freight packages can be handled cheaply and quickly another obstacle in the way of suburban life disappears. However, we think that in most cases where the carrying of this traffic is practicable it will appeal to the manager from the standpoint of cash revenue, as well as induced passenger traffic.

SOME of the convention papers remind us that street railway practice is, in some particulars, becoming settled enough so that the adoption of standards is not only practicable, but would be a great advantage. Things have been in a very chaotic state since the adoption of electricity, and it is only recently that it would have been practicable to adopt any standards. The conditions on street railways are so variable, as compared with those on steam roads, that the adoption of standards that will suit a large number is more difficult than on steam roads. The argument that the adoption of standards prevents all improvement and progress, has a little weight, but very little, because those who do not care to conform to the standard used by the majority can still obtain their supplies as cheap as before, while those who have adopted the standard ought to get them cheaper than before. The interchange of cars does not necessitate standards in our business at present, so that the main argument is that of cheapness and convenience. If a number of companies will unite on some standards they will immediately begin to realize the benefits of the new arrangement, while those who do not will be no worse off than before.

ONE who travels much among street railways and has an opportunity to observe the way in which different lines are managed, is impressed with the varying emphasis which is put upon the several branches of street railway service by the superintendents of different systems. On one line the greatest attention is given to the appearance of cars and trainmen, and everything is done to put on a good appearance at the points where the company meets the public. At the same time the service may be very inferior as regards frequency and public accommodation, or, on the other hand, the road may be going to ruin mechanically and electrically. A manager who is by taste an electrical, mechanical or civil engineer is liable to fall into the opposite mistake of paying attention to the

mechanical and electrical details, to the detriment of the other departments mentioned. The successful manager must be a man of wide vision, and he must know enough to hire competent men to do what he cannot do with advantage himself. It is one thing to operate a road economically. It is another thing to get passengers to ride on it. These two elements of management seem sometimes to be almost opposed to one another, and it is only the successful manager that knows how to combine them.

MOTORMEN are not usually the careless and blood-thirsty individuals they are sometimes made out to be by the daily press, but there are a few careless ones always, and it may have the effect of making them more careful if they are reminded that within the past sixty days two motormen have been indicted for manslaughter. In one case (that of a motorman on the Newark & South Orange Street Railway) the man was found guilty and sentenced to one year at the penitentiary. It was proved to the satisfaction of the court that the motorman was not properly attending to business, and that at the time of his running over the child, he was not looking ahead, and did not have hold of the brake or ring the gong. The other case was at Quincy, Ill., and the man was acquitted. He was one of the company's most reliable men, and it was proved that the accident was beyond his control. Two ladies in a carriage drove onto a trestle in a dark hollow at night. The trestle was not a part of the carriage driveway. It was impossible to see many feet ahead, and the car ran into the carriage, killing one of the ladies. The motorman, as was shown in court, did his best to stop, and so was acquitted. It is all right for the company to stand by the boys in troubles of this kind, but prevention is better than cure, and it will have a good effect on the careless ones to have them understand that while the company pays the damage suits, it cannot prevent them from being convicted of manslaughter if they do not attend strictly to business.

THE time for car heating is again here, and the managers who have not adopted electric heating are casting questioning glances in that direction. Electric heating received a black eye at the start, from two causes: burnouts, and not enough heat with the current claimed by the makers as sufficient to heat a car. There have since been as great improvements in heaters as in street railway motors, and the amount of current necessary to heat a car is now known from actual practice, so that the use of electric heaters is not as much of a question of guess work as formerly. This being the case, electric heating is now ready to advance on a well-known and established basis. There is probably not much doubt but that electric heating on the majority of roads is more expensive than coal stoves. It even goes so far sometimes as to require an expensive addition to the power station machinery, because its load comes heaviest at a time when the load would be heaviest were no electric heaters used, and hence the maximum station capacity has to

be increased. In spite of all this, electric heating is steadily coming into favor. Electric heating is more expensive than coal. So is gas and electric light more expensive than kerosene. So is a well lighted, well fitted up car more expensive than a cheerless, dimly-lighted one. When it comes to a question of public comfort, expense has to take a back seat. At least that has been the history of both steam and street railway practice. Electric heaters heat a car evenly and near the floor, two things that a coal heater does not, and for that reason are immeasurably more comfortable for passengers, especially those that make long trips. This is the secret of the electric heater's success. The electric heater is not coming in with a rush, and it will be a long time before the car stove will disappear. On small roads where passengers take short rides, and the heat of the car does not make so much difference, the cheapness of the stove will keep the electric heater out for a long time but there are plenty of roads where the electric heater will be forced in as has been the electric light, not because of its cheapness, but for its convenience and comfort.

STORAGE batteries, as usual, are not profitable. The report of the Birmingham, England, Tramways Company, for the year ending with June, states the cost of the working of different systems in that town. Electric storage cars cost 14.70d. per car mile; steam trams, 10.02d. per car mile; horse trams, 9.43d. per car mile; and cable trams, 5.67d. per car mile.

THE tramway cars at Chemnitz, in Saxony, have no conductors. There is a fare box at either end of the cars, as in this country. By doing away with conductors a saving of 44,000 marks a year has been effected. If 450,000 persons evaded paying the fare (10 pfennig everywhere) in the year, the loss would just counterbalance the saving. But the number of evasions is probably very small in a population who are in the habit of having their restaurant and beer shop scores left to their honor. If culprits are detected, their names are "posted" in the newspapers.

THE city of Baltimore has been giving the matter of car fenders an unusual amount of attention for the past year, and on September 28 a culmination was reached by the passage of an ordinance requiring all cars to be provided with an improved fender within three months, with a penalty of \$5 per day per car for non compliance. Each car must be provided with both front and wheel guards in accordance with the ideas embodied in the report of Mendes Cohen, engineer of the fender commission. The fenders must be approved by the mayor, register, and city commissioner, who must certify in writing that the fenders comply with the requirements laid down in Engineer Cohen's report to the commission. It seems not unlikely that the company can not now be held liable for damages in accidents having any connection with the fenders.

## STATE ASSOCIATION CONVENTIONS.

Three state associations held their meetings just prior to the annual convention. One was the pioneer, the Ohio, another was the lusty youth, the New York, and the third was the baby, Michigan.

### NEW YORK.

The twelfth annual meeting of the Street Railway Association of the state of New York was held at the Yates, Syracuse, September 18, with President D. B. Hasbrouck at the motor. Twelve companies were represented, besides a goodly company of thirty-two supply men and others. The report of the treasurer showed receipts, \$5,860.09; expenses, \$5,381.20; balance, \$478.89. The executive committee reported a membership of thirty companies, the highest yet reached. The Forty-second Street Manhattanville & St. Nicholas Avenue Railway Company withdrew, and the Syracuse Street Railway Company, the host, and the Hornellsville Electric Railway Company have been received. Papers were read by J. B. Craven on "Economy in Electric Power Stations;" George W. McNulty, "Recent Improvements in Cable Traction;" Allen R. Foote, Washington, D. C., "Taxation." Following are the new officers: President, G. Tracy Rogers, Binghamton; vice-presidents, John H. Moffitt, Syracuse; William W. Cole, Elmira; secretary and treasurer, William J. Richardson, Brooklyn; executive committee, D. B. Hasbrouck, New York City; John N. Beckley, Rochester; Daniel F. Lewis, Brooklyn. Albany will be the next meeting place.

### MICHIGAN.

The Michigan Street Railway Association held its first annual meeting September 19 at Grand Rapids. Eight companies were represented, St. Joseph & Benton Harbor Street Railway Company, Benton Harbor; City Electric Railway Company, Port Huron; Muskegon Railway Company, Muskegon; Manistee, Filer City & East Lake Railway Company, Manistee; Consolidated Street Railway Company, Bay City; City of Saginaw Street Railroad Company, Saginaw; Lansing City Railway Company, Lansing; Consolidated Street Railway Company, Grand Rapids.

Papers were read by W. Worth Bean on "Construction, Maintenance and Operation of Small Street Railways;" C. M. Swift, "Suburban Electric Railways and their Possibilities;" David D. Erwin, "Street Railway Accidents and Fire Insurance."

The new officers are: President, W. L. Jenks, Port Huron; vice-president, W. Worth Bean, St. Joseph; secretary and treasurer, B. S. Hanchett, Jr., Grand Rapids; executive committee, the officers and David H. Jerome, Saginaw, and Strathern Hendrie, Detroit. The next meeting will be held in Grand Rapids, December, 1895. The association is a strong one for its age, and will be of great value to the street railway interests of the state.

## OHIO.

The annual meeting of the Ohio State Tramway Association took place at the Boody House, Toledo, Ohio, September 26th, at 9 o'clock a. m. President Albion E. Lang, of the Consolidated Street Railroad, Toledo, welcomed the members in a short address. The papers under discussion were: 1st—The best method of collecting fares; 2d—A desirable and satisfactory fender; 3d—What are the best qualifications for car and motor men; 4th—The treatment of low joints in rails, and how to prevent them.

Among those present were Albion E. Lang, Consolidated Street Railroad, Toledo; James Robinson, Toledo Street Railroad, Toledo; J. K. Newcomer, Delaware Electric Railroad, Delaware, O.; R. Carpenter, of the Mansfield Street Railroad, Mansfield, O.; B. P. Foster, Toledo & Maumee Valley Railroad; W. F. Kelly, Columbus Street Railroad, Columbus, O.; W. S. Jewell, Consolidated Street Railroad, Toledo; J. B. Hanna, Cleveland City Railroad; W. G. Owens, Des Moines Street Railroad, Des Moines, Iowa, and others. The supply trade was represented by C. M. Fuller, of the Davis Car Shade Company; H. H. Foster, the Dreher Manufacturing Company, New York; John Dale, of the Dale Manufacturing Company; E. A. Smith, Consolidated Car Heating Company. The members and guests were entertained by visits to various industries in Toledo, and a banquet in the evening at the Toledo Club. This association is the pioneer of street railroad associations, having been thirteen years in existence. The place for the next meeting was referred to a committee who are to report at a later date.

## EATON CAR FENDER.

HENRY W. EATON, 45 Williams Street, New York, has patented a car fender, shown here, the illustration being

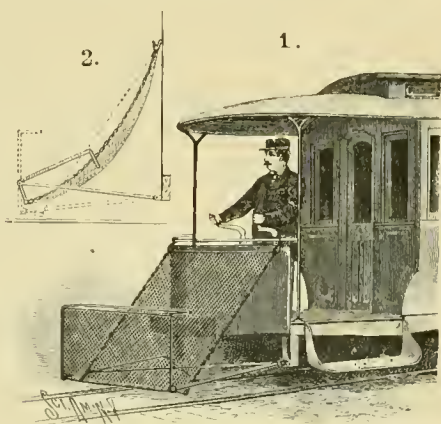

from the scientific American. A forwardly extending lower frame work is connected by a hinge joint to the car, and chains extend from the forward end of the frame to hooks at either side of the dashboard. The chains are connected by a netting and are only indirectly connected with the lower frame, being attached at their outer ends to the arms of a swinging frame pivoted to the lower

frame, and which extends normally upwards, as shown in Figure 1, this frame when turned over as shown in Figure 2, striking the chains and network to depress them near the center, and swinging them and the frame up slightly at the front end of the fender.

## HEAVY CURRENT SWITCHES.

The illustration shows the new switch manufactured by the W. S. Hill Electric Company for railway and central stations. For the past year these switches have been in use in very large numbers, one power station alone having over 300 in use of from 500 to 400 amperes capacity. The improvements (which are covered by patents) consist in broadening the ends of the blades and yoke so as to admit of using two bolts. This unites the two so firmly that it prevents all twisting or straining of the parts while the switch is being operated.

The method of backing up the flexible brush contacts by plates of pure copper, practically converts the blade and contact into one continuous piece of metal, and as the size of all the carrying parts are computed at 1000 circular mils per ampere, it will be seen that perfection has been attained. The company reports business good in all its lines, but more especially brisk in switchboards, some of the largest and finest ones in the country having been lately turned out.

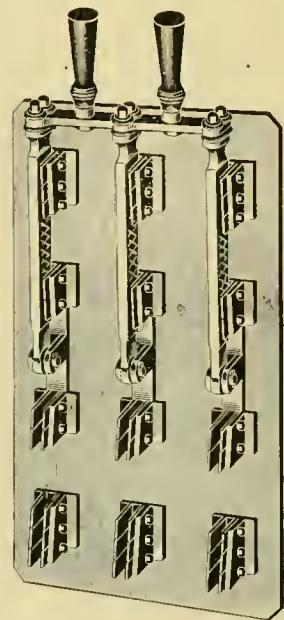

## A LONG INDIANA INTERURBAN.

The lines of both Goshen and Elkhart, Indiana, have been purchased by the Indiana Electric Railway Company. The old line of Elkhart is now being reconstructed and will probably be running in 60 days. Construction has been begun in Goshen and between Goshen and Elkhart. When the system is finished, this company will operate  $6\frac{1}{2}$  miles in Elkhart, 4 in Goshen and 60 miles of interurban to other towns and pleasure resorts. The distance from Goshen to Elkhart is about ten miles. Goshen is the county seat of Elkhart county. The towns are now connected by two steam roads. The new roads will handle baggage, freight and express matter. The officers are J. J. Burns, president and general manager; W. L. Stonex, secretary, and J. Clyde Brown, chief engineer and general superintendent.

THE electric line of the South Covington & Cincinnati Street Railway Company, between Cincinnati and Ludlow was opened for traffic September 24.

## BRAKE SHOES.

Abstract of a Paper read before the American Street Railway Association by D. F. Henry, President Federal Street and Pleasant Valley Passenger Railway Company, Pittsburg, and Powell Evans, Foundry Sales Agent of William Wharton, Jr., & Co.

The street railway is quite as old as the steam railway proper. Owing to the immensely greater size of the latter, however, early in its existence the importance of even insignificant items of cost in construction and maintenance was made clear. Economy required on every hand the adoption of standards wherever possible for each system. This principle then extended to the adoption of standards, applying not only internally to each system, but externally to all systems.

The necessity for standards was the prime cause of existence of the Master Car Builder's Association, which includes representatives from about every steam railway company in the United States. This association has collected most facts relating to the operation of all lines, and gradually reduced the greater number of details to standards. Among other net results at the present time are— the standard track gauge, coupler, wheel, and all such parts as must necessarily be similar to permit cars from any one line to be operated on any other.

If standards have proven simpler and more economical in every way for steam roads, the fact should apply with equal force to street railway operation. Much as been done in this direction, but there is more still before you.

It is not, and probably never will be, possible for all managers to agree on all points; but why should there be a difference of height of car floor above track, or diameter of wheel, on any two new or remodelled street railway lines? For our city and suburban service practically similar conditions exists all over the country, and like the steam railways we should have universal standards.

With the increase of standards comes a parity in the experience of those using them, and by the continued comparison of such experiences it becomes possible to approach perfection. When standards are adopted, we need not carry a large stock of the various parts; and our men, becoming familiar with these parts, can save time and money in replacing them when broken or worn out.

I believe in standards throughout; but now wish to call your special attention to the subject of the "shape" and "material" for brake shoes.

An extract from a letter by W. W. Whitcomb, President of the Composite Brake Shoe Company, of Boston, in the "Street Railway Journal" of September, 1893, aptly emphasizes the need of reformation in this matter. He says:

"Giving attention more particularly to rolling stock, I have been struck by the fact that there is a great lack of uniformity or standard in the numerous repair parts, a state of affairs which the manager knows only too well. Take, for instance, brake shoes and their connection with the brake mechanism. Having occasion some time ago to visit a large and widely known truck manufacturing concern, I was shown nearly one hundred different styles of brake shoes, many of them differing only in some small detail, yet enough to unfit them for any truck except the one for which they were designed; and the end is not yet with them. At another truck company's works the managers failed to recognize a drawing of one of their own shoes, made some years before. This condition of things, annoying in the extreme to the buyer, ought not to exist, and a remedy for it should be adopted. That such a remedy can be found only in the adoption of some standard, suitable alike to all makes of trucks and their brake mechanism, will be readily admitted."

His logic seems perfectly sound.

The steam railways have reduced the parts of their brake-gear to a standard of shape—the beam, link, release spring, hanger, clevis and shoe. They have found designs good enough for all to use, and so good that no one road seems able to improve upon them.

Having decided upon these standards, they specify them when buying rolling stock, get them, and use them. Why should not our various truck manufacturing companies use a standard brake attachment; and if they can, why do we not decide upon one, and insist upon its use? As was stated above, the steam railways some time ago settled the matter of "shapes," so this point does not appear in their recent discussion on brake shoes.

As regards "material" they are still undecided; but are unanimous on one fact, viz.: that the best thing for one road is best for all. Is this not true also among our roads?

I will assume here that it is.

The Master Car Builders' Association has spent much time on this matter, and I will now read you in condensed form their last report of 1893.

After an introduction, Mr. Cloud, secretary of the association, goes on to say:

"We find that the annual requirements for brake shoes for cars and engine tenders owned by roads represented in the Association by representative members, is 55,000 tons. It may be said that approximately two-thirds of this metal is worn out in service and that the other one-third is returned as scrap, although this estimate of the average scrap weight is an estimate based on general knowledge, and not on any absolute statistics.

It is perhaps correct to state, that notwithstanding the use of wooden brake shoes in England until a comparatively recent date, the earliest valuable results of experiments on friction of metal brake shoes were presented by Capt. Douglas Galton, to the Institution of Mechanical Engineers of Great Britain some fifteen years ago. The experiments were made with steel-tired wheels, and the results show very clearly the intricate character of the question of brake shoe friction under variable conditions of service in railway trains. In support of this statement, the following table of coefficients of friction at varying speeds with the cast-iron brake blocks on steel tires is given from a paper read by Capt. Galton before the Institution of Mechanical Engineers of Great Britain in April, 1879:

Number of experiments from which the Mean is taken.	VELOCITY.		CO-EFFICIENT OF FRICTION.		
	Miles per Hour.	Feet per Second.	Extremes Observed.		Means.
			Maximum.	Minimum.	
12	60	88	.123	.058	.074
67	55	81	.136	.060	.111
55	50	73	.153	.050	.116
77	45	66	.179	.083	.127
70	40	50	.194	.088	.140
80	35	51	.197	.087	.142
94	30	44	.196	.098	.164
70	25	36 1/2	.205	.108	.166
69	20	29	.210	.133	.192
78	15	22	.280	.131	.223
54	10	14 1/2	.281	.161	.242
28	7 1/2	11	.325	.123	.244
20	Under 5	Under 7	.340	.156	.273
.....	Just moving.	Just moving.	.....	.....	.330

It will be seen that the co-efficient of the friction is not only variable through a large range under the same speed, but that it varies very greatly with the speed under these conditions, increasing as the speed decreases.

It was also found that the co-efficient of friction decreases rapidly with the increase of time that the shoes were in action upon steel tired wheels when there was no reduction in the speed, as shown in the following table of co-efficient of friction as affected by time, also reported by Captain Galton from a smaller number of experiments:

SPEED.	Commencement of Experiment.	CO-EFFICIENT OF FRICTION.			
		After 5 Seconds.	After 10 Seconds.	After 15 Seconds.	After 20 Seconds.
20	.182	.152	.133	.116	.099
27	.171	.130	.110	.081	.072
37	.152	.096	.083	.069	.....
47	.132	.080	.070	.....	.....
60	.072	.063	.058	.....	.....

It must be remembered that all the experiments above reported by Captain Galton were made with cast iron brake blocks, on steel tired wheels, which is not a condition prevailing generally in the practice of this country, except on many passenger trains.

The most reliable results obtained experimentally by the use of different shoes on chilled wheels and with different brake arrangements at the present time in hand, are those obtained by the Pennsylvania Railroad Company (which furnishes the information) in various tests conducted during the past two years.

Table "B" presents selected runs for the purpose of making comparisons between runs in which the pressure in the brake cylinder varies between close limits of 30½ minimum and 42 lbs. per square inch maximum. In this table "B" the figures have all been reduced on theoretical basis to 40 lbs. pressure to the square inch, thus giving a number of cases which can be very accurately compared with one another. At the bottom of the table the averages are given with each kind of shoe, and the percentage for comparisons.

TABLE "B." BRAKE RESISTANCES.

No. of Run.	Cast Iron Shoes Pounds of Resistance.	No. of Run.	Composite Shoes Pounds of Resistance.	No. of Run.	Steel Shoes "Z." Pounds of Resistance.	No. of Run.	Steel Shoes "M." Pounds of Resistance.	No. of Run.	Steel Shoes "D." Pounds of Resistance.
121	2308.40	71	2212.80	99	1698.00	18	2059.60	150	1946.80
122	2334.80	73	2236.00	96	1721.20	15	2059.60	156	1977.60
124	2403.20	75	2307.60	100	1738.40	17	2079.60	155	2008.00
123	2412.80	74	2310.00	97	1743.60	16	2108.80	149	2012.80
128	2454.40	185	2322.40	48	1767.60	.....	.....	158	2020.00
127	2462.40	187	2340.00	50	1810.40	.....	.....	35	2045.20
8	2470.80	180	2350.40	51	1836.40	.....	.....	159	2092.80
125	2476.60	184	2362.80	95	1867.20	.....	.....	34	2095.20
126	2480.60	188	2364.00	.....	.....	.....	.....	30	2135.60
9	2577.60	193	2370.40	.....	.....	.....	.....	29	2159.60
.....	.....	191	2372.80	.....	.....	.....	.....	.....	.....
.....	.....	186	2405.20	.....	.....	.....	.....	.....	.....
.....	.....	192	2410.40	.....	.....	.....	.....	.....	.....
.....	.....	182	2414.40	.....	.....	.....	.....	.....	.....
.....	.....	190	2449.20	.....	.....	.....	.....	.....	.....
.....	.....	183	2453.20	.....	.....	.....	.....	.....	.....
Average.		Average.		Average.		Average.		Average.	
2439.36		2355.70		1772.85		2076.90		2049.36	
Per cent.		Per cent.		Per cent.		Per cent.		Per cent.	
100		96.58		72.68		85.15		84.02	

Table "C" presents a comparison of the actual distances for four tests with each kind of shoe in which the air pressure and the speeds were almost exactly alike. It also includes a percentage comparison of the average of the four runs with each kind of shoe.

TABLE "C."

### COMPARISON OF FOUR RUNS UNDER THE SAME CONDITIONS.

#### DISTANCE RUN AFTER BREAKING.

No. of Run.	Cast-Iron Shoe Feet Run.	No. of Run.	Composite Shoe Feet Run.	No. of Run.	Steel Shoe "Z." Feet Run.	No. of Run.	Steel Shoe "M." Feet Run.	No. of Run.	Steel Shoe "D." Feet Run.
8	1806	192	1887	49	3087	15	2471	157	2162
7	1893	184	1927	50	3904	17	2575	150	2866
9	1805	68	1941	51	3820	16	2708	20	2307
6	1834	65	1865	101	3425	18	2720	34	2594
Average.		Average.		Average.		Average.		Average.	
1834		1905		3561		2618		2482	
Per cent average.		Per cent average.		Per cent average.		Per cent average.		Per cent average.	
100.00		103.87		194.16		142.69		135.33	

Two tests were made to compare the durability of the cast-iron, composite and the three different grades of steel shoes in continued service, and incidentally the wear of the wheels was also noted.

The car on which the tests were made required sixteen shoes, which were made up as follows in the first test:

- 4 Cast-iron shoes.
- 4 Composite shoes.
- 4 Steel shoes "Z."
- 2 " " "D."
- 2 " " "M."

Grouping the two grades of steel, "M" and "D," together as from one foundry, the total wear of the four shoes of each manufacture was as follows, while the car ran:

KIND OF SHOES.	WEAR.	
	Actual Pounds.	Percentage Comparison.
4 Cast-iron .....	23,530	100
4 Composite .....	11,394	48.4
4 "Z" Steel .....	2,337	9.9
2 "D" " .....	1,680	7.1
2 "M" " .....		

A second test was made to determine the durability of the shoes, and, if possible, to get a better record as to the relative wear of the wheels, and the following table gives the results, including also a statement of the relative distances run after the application of the brakes, taken from the former tests reported.

Three sets of cast-iron shoes were practically worn out during these tests, and one set of composite shoes, while the steel shoes were not much worn. So far as the wear of the wheels is concerned, the results were somewhat contradictory, and inasmuch as a large portion of the wear of the wheels is from the rail, it would be unsafe to ascribe all the difference to the shoes.

#### COMPARATIVE WEAR OF CAST-IRON, COMPOSITE AND STEEL BRAKE SHOES.

KIND OF SHOES.	WEAR OF				Relative Distance Run after Application of Brakes. Taken from other tests.	REMARKS.
	SHOES.		WHEELS.			
	Pounds.	Per Cent.	Reduction in Circumference in Inches.	Per Cent.		
Cast-iron .....	94.690	100.00	2.812	100.00	100.00	12 Shoes worn out
Composite .....	37.635	39.75	2.343	83.32	103.87	4 " "
Steel "D" .....	5.708	12.06	1.156	82.21	135.33	2 Shoes slightly worn
Steel "M & D" .....	10.220	10.79	2.437	86.66	139.04	4 " "
Steel "M" .....	4.532	9.57	1.281	91.11	142.69	2 " "
Steel "Z" .....	8.194	8.65	2.969	105.58	194.16	4 " "

A discussion follows, which Mr. Rhodes initiates by saying:

"The report says that the composite shoe consisted of cast-iron with a small percentage of wrought iron in the rubbing surfaces extending through the shoes, the percentage of wrought iron being somewhat less than seven per cent of the whole surface. I want to call the attention of the association to this point, so that we will not fall into any error. On our line we use a composite shoe, and have for a number of years, on account of the saving which we find by using that shoe. But it is not a shoe of this character. It is not a composite shoe with only seven per cent of wrought iron in it. It has in the neighborhood of 40 per cent of wrought iron. I can readily see that a test made of a shoe with only seven per cent of wrought iron might give entirely different results."

Mr. Marden: I think this matter of metal for brake shoes is one, perhaps, of more importance than we are giving it credit for. It is one in which there is a daily outlay by the various roads, and the outlay may be made more or less as we give it study and as we experiment, perhaps, with metal for use in brake shoes. And it seems to me that it is a matter which ought not to be passed over so lightly. I think our secretary is deserving of credit for the report which he has presented to us, as it contains quite a little that may give us a chance to study during the coming year. We have made, on our road, quite a number of experiments as to different metals for brake shoes, and we find that on steel-tired wheels we cannot run with as good results with the same kind of metal as we can on chilled wheels. In fact, we are using to-day nothing but chilled brake shoes on steel-tired wheels. Other roads, I understand, are using a composite, or some other kind of shoe, perhaps with better results. On cast-iron wheels we are using a composite shoe, and we are also using what is known as a Conglon shoe. I should be very glad to have an extended discussion of this matter of metal for brake shoes and to take further part in it as the discussion progresses.

Mr. Lewis: I agree with Mr. Marden in what he says of the importance of this subject. It has been shown by the report of the secretary that it involves the expenditure of a large amount of money in the annual consumption of brake shoes. The question of consumption



or wear of the metal is one that is worthy of consideration. I do not claim to know very much about the co-efficient of friction or the resistance of the different metals in brake shoes. But we do know that we get good results from the use of all the different varieties of brake shoes mentioned, and there is not any of them that has developed any serious weakness. When you refer to the test you will notice that the consumption of cast-iron shoes is stated to be 23,530 pounds, while the consumption of steel shoes is from 1,680 to 2,337 pounds. In other words, you have used nearly twenty times as much cast iron in the same service as you have of steel. It is assumed, of course, while the mileage is not given, that the mileage given by the different kinds of shoes mentioned in the report was the same. Now, the difference in the cost between the steel, composite or cast iron, is not above a ratio of 2 or 3, while you notice that in the wear the ratio is 1 to 20.

Mr. Waitt: In connection with what Mr. Lewis has said, there is another feature that comes in for consideration—the matter of the length of time that the shoes of various manufactures will wear is offset considerably by the amount of shoe resistance or holding power of the various metals. I notice on page 16 and then again on page 15, the two tables there show that there is a material difference in the resistance between cast iron and steel, the steel in the tests running an average of only 2,049 as against 2430, or only 84 per cent of the holding power of cast iron. It seems to me that this should be taken into consideration, and that we should not base a decision as to what is the best metal for brake shoes entirely upon the wear.

Mr. Sanderson: We made some trials (I think it was four years ago) with some heavy shifting engines, putting cast iron shoes on one side of the engine and steel shoes on the other. We found that the steel shoes outwore six and one-half sets of cast iron shoes. We have been using cast steel shoes since then on the driving wheels on all our larger engines on heavy mountain service, where much sand is used, and we find that the steel shoe cuts down the tires about as fast as they wear on the rails.

Mr. Lewis: In regard to the effect of different metals on the steel tire or on the wheel, we know that the Ross-Meehan shoe is designed to wear the part of the wheel that is not in contact with the rail nearly as fast as the wheel wears where it is in contact with the rail. The fact is that we never have seen a shoe constructed in that way that has worn the wheel as fast as the rail will wear it.

Mr. Sanderson: There is one other point I would like to raise; that is the work that is done in stopping a train by the application of the shoe to the wheel has to be absorbed in some way disposed of. It is either done by grinding off metal or by producing heat. Is it not better to grind off a little more metal and keep the wheels cooler rather than run the risk of cracked wheels or loose tires?

Mr. Cloud: Does Mr. Sanderson mean to indicate that the more metal that is ground off by different grades of shoes the less would be the heat generated?

Mr. Sanderson: I thought a soft cast iron shoe would let its particles be torn off and would generate less heat in doing it. At the same time the energy would be absorbed in tearing the metal apart rather than producing high heat.

Mr. Cloud: I should like to say, inasmuch as I prepared this report, that I understood the president to desire me to get together some data which might convince the members of the importance of a thorough investigation of this subject. Now, these tests which are reproduced here are from the Pennsylvania Railroad and are not offered at all as conclusive or as of sufficient importance to warrant any deductions whatever, but simply as so much information, which is a mere handful compared with what we ought to have. I have referred in the report to the fact that in dealing with the amount of metal used per year I dealt only with one side of the question and entirely left out of consideration the other and very much more important side of the question, which Mr. Hayward has referred to, namely, the efficiency of the brake. But I could only present to you what I could get in a short time."

The discussion then turns on the method of having experiments made—whether by individual roads, or at the expense of the association.

This ends the report as far as concerns us. The following extracts from letters from two wheel manufacturers and one brake shoe manufacturer will show their views on the question of friction between wheels and shoes.

The first of these is from Mr. Charles V. Slocum, casbier of the New York Car Wheel Works, Buffalo, N. Y., in which he says:

"The best mechanics acknowledge that two metals of extreme hardness coming together with resistance, as in the case of wheel and brake shoe, do not adhere, but will eventually heat and burn.

As you are probably aware, the treads of cast-iron wheels have the hardest surface which it is possible for the manufacturers to provide, and this hardness is absolutely necessary for the service required. This surface cannot be touched by a tool to any extent. It is harder than hard steel, and when brake shoes of the same material are used, or shoes of considerable hardness, friction results instead of wear, with a consequent burning of the treads of wheels, in many instances shortening the life of the latter and putting the railroad company to a great deal of expense in replacement of wheels or in having them refitted; hence it becomes a question of wheels versus brake shoes.

In other words, will railroad companies prefer to buy the harder and more expensive brake shoes for the purpose of economizing in the consumption of the same, or will they prefer to buy softer brake shoes, as, for instance, the ordinary soft casting worth from 1¼ to 2½ cents per pound, according to the quantities purchased, with a total investment per shoe of 20 to 50 cents, or will they prefer to economize in car wheels, which cost from \$3 to \$65 each, according to style, size and kind?

The shoes are very readily replaced, with very little expense. No car wheel can be replaced to any advantage without taking out the truck, pressing off the wheel, pressing another on, replacing it in the truck, and replacing the truck under the car. The expense of replacing one wheel has been variously estimated at from \$2 in steam railroad service up to \$10 in street railroad service, where the motor has also to be removed and the gear taken from the axle.

That, it can be seen, is comparatively expensive, and does not include the cost of the wheel itself burned by the hard brake shoe, nor the cost of the new wheel to take the place of the burned one. Including these two items, a conservative estimate of the cost of replacing a brake burned wheel under a motor car would be \$20, and where a company is not well equipped with facilities for doing the work, the expense would be far greater.

The cost of replacing a brake shoe might possibly be \$1, including the cost of the old and new soft casting and all the labor involved.

Street car wheels are ordinarily guaranteed to run from 25,000 to 35,000 miles in service under ordinary conditions, and will often make double these figures in actual mileage if not actually prevented. Hence it is a question which every master mechanic must decide, as to whether the wheels shall be assisted in giving good service by the use of soft brake shoes, or whether they shall be hindered, and in many cases actually prevented from giving satisfactory results by using friction, instead of resistance, in the stoppage of cars."

The second statement is from the Philadelphia Car Wheel Company, Philadelphia.

"It is a well-known fact that when two metals are very hard and are brought together, they do not adhere, but will heat and burn.

Cast-iron wheels are chilled on the tread, and are made as hard as it is possible to make them, and if the brake shoe is made and chilled in the same manner, instead of adhesion and wear on the brake shoe, we have friction between the two surfaces, which results in the burning of the tread of the wheel, which unfits it for future service.

The difference between replacing new wheels and new brake shoes is so very great that there is no question but that a brake shoe made softer than the wheel is far more preferable and economical than when made with chilled face, and we, of course, would commend the use in every case of a brake shoe made from ordinary iron.

In this connection we would like to call your attention to the flange of motor wheels. A great deal of the wear on wheels has been on the flange, and if this is not made of sufficient thickness, it will chip and break long before the chill is worn from the tread, and much of the rail now in use has been made with a groove too narrow to take in more than ¾ flange, and this is entirely too small for a motor wheel.

We enclose blue print showing a section of our standard motor wheel flange, and trust when the subject of brake shoes is taken up at the convention, that this will be given consideration."

The third is from Mr. Whitcomb, of the Composite Brake Company, cited before. He states: "From observation and discussion in railroad clubs by the steam railway mechanics, I have become strongly of the opinion that a chilled brake shoe should never be used in street railway service, and with but few exceptions they are being condemned and thrown out. They may give more service, but it is usually at the expense of the wheel, and a constant risk of acci-

dent and disaster to the traveling public. In the electric service, for instance, where considerable speed is attained, and frequent and sudden stops necessary, a chilled shoe should be prohibited in my opinion."

In connection with the first two above citations, it is well to note that with us there is not much danger of burning the wheels, but the remarks on wear do apply, and with force.

I now wish to give you some figures which will show the cost of this brake shoe business to us, and therefore its importance.

In round numbers there are on all lines of street railways in the United States, 50,000 cars, including steam and electric motors, cable grip cars, trail and horse cars. These should not properly be lumped, as they include varying factors of weight and speed, varying the brake services required but for the result in view, using low averages, this lump figure will be sufficiently accurate.

Assuming an average mileage of 75 miles per day for all cars, including an allowance made for cars used in rush hours only, and others under repair, the total result would be 3,750,000 car miles per day. Taking the average life of brake shoes at 5,000 car miles, and

an average of 5 shoes per car, there is a daily consumption of 3,750 brake shoes, and an annual consumption of 1,368,750 shoes. At an average weight of 21 pounds each, new, the total weight is 28,743,750 pounds; at 2 cents per pound, amounting to \$574,875. I will deduct from these amounts an average weight, per shoe, of 9 pounds when worn out, amounting to 12,318,750 pounds of scrap, at 1/3 cent per pound, equal to \$41,062, leaving a net balance of \$533,813. This represents what we pay annually for metal actually ground to dust, braking our cars. To this we must add the cost of labor in changing the shoes. Allowing 30 minutes per shoe for replacement and adjustment of rods, etc., and \$2 per ten hours per day for labor, this total amount charge would be \$136,875. Adding this last figure to the net cost of metal gives us the total annual charge of \$670,688 for brake shoes, equal to about \$13.70 per average car, from which you can roughly estimate the cost of this item for your respective roads.

It is self-evident that if you select a metal which will give you a greater car mileage than 5,000 miles; or a shape which will permit you to use more of your 21 lbs. of new shoe than 12 lbs for braking, and therefore, less than 9 lbs. for scrap; or if your shape is readily

No.	MATERIALS.					SHAPE.					REMARKS.	
	Weight of Cars.	Mileage of Wheels.	Mileage of Shoes.	Stop per Mile	Gradients.	No of Truck Patterns.	Shoe Patterns No Hangers.	Shoe Patterns Separate Hangers.	Stand. Shoe Wanted.	Stand. Shoe Hanger Wanted.		
7	No	Re-	ords	at	all							
8	12 to 22 m.	Abt. 225 m.	Abt. 75 m.	.....	As high as 10% and plenty of them.	4 sty Brill.	.....	One	.....	Yes		Shoes wear down to 1/4 in. in thickness or less before giving out.
9	.....	.....	.....	.....	.....	.....	.....	.....	.....	Present Practice		Shoe inter. and fit stand. hanger.
10	.....	.....	.....	.....	.....	1	.....	.....	.....	.....		Shoes from Bemis Co. only.
11	.....	.....	.....	.....	6% heaviest	1	.....	.....	.....	Yes		Use shoes as made by truck m'frs.
12	.....	.....	.....	.....	.....	5 or 6	.....	.....	.....	.....		60% chilled iron 20% soft, Lappin.
13	.....	.....	.....	.....	.....	3	6	.....	Not possible	Yes		Chilled iron in shoes
14	Abt. 12 m.	25 to 30 m.	.....	.....	.....	3	.....	.....	Yes	.....		Hard iron shoe to brake on tread only.
15	15 m.	35 m.	3 m.	73 m. per cent wheels	Not over 7%	2	.....	.....	.....	.....		60% soft I. C. I. with wood, also steel plugs. Medium C. I.
16	4 to 6 1/2 T.	20 to 60 m.	4 to 7 m.	Abt. 10 per m.	2 1/2 to 5 1/2%	2	.....	3	Not possible	Yes		Congdon shoe (cast steel plugs in C. I.)
17	12 m.	55,224	4,804	5 per m.	3 to 6%	1	.....	1	.....	.....		Soft iron and wood, "ill-fitting hangers."
18	1/3 Ca. 7 1/2 m	1/3 E. 14 1/2 m	40 m.	7 m.	8 per m.	Level	.....	1	.....	Yes		Ordinary C. I. shoe.
19	6 to 8 m.	Abt. 40 m.	Abt. 12 m.	.....	0 to 12%	2 Brill.	.....	.....	.....	Yes		Chilled iron shoes—2 patterns.
20	4 to 5 T.	.....	.....	.....	Highest 2%	2	.....	.....	.....	Yes		Soft iron with wood plugs.
21	Abt. 6 1/2 T.	30 to 32 m.	.....	.....	.....	2	.....	.....	.....	.....		Soft iron shoe.
22	.....	.....	.....	Very frequent.	One of 10%	2	1	2	.....	Yes		Have used soft I. and hard I. and I. and wood plugs.
23	.....	.....	.....	.....	8 to 9% in places.	2	.....	.....	.....	Yes		Have used soft I. and hard I. with wrought plugs, and wood.
24	7 to 8 T.	One year.	9 m.	Very frequent.	6%	4	2	1	.....	Yes		Same as 25 above Note letter about skidding of wheels.
25	12 to 15 m.	30 to 40 m.	5 to 7 m.	Not frequent.	Abt. level.	6	3	3	.....	Yes		.....
26	5 T.	Not worn out but flat in 5 years.	6 m.	5 to mile	0 to 6%	4	.....	.....	.....	Most emphatically		.....
27	4 to 6 1/2 m.	One year.	2 to 8 m.	Ev'ly 300 ft.	0 to 6 1/2%	4	2	2	.....	Yes		See his note. Prefers hard I. Thinks soft I. wears wh'ls faster than hard I. Impossible for one shoe to suit all railway men.
28	1/3 Ca. 7 m	1/3 E. 16 m	33 m.	.....	As usual in cities.	One each railway	.....	Loop hanger bolted to brake bar.	.....	Durable but hard to keep good fit		Congdon shoes. C. I. with W. I. plugs McGuire type shoe, chilled iron wheels.
29	11 m.	45,380	.....	.....	5% heaviest	2	.....	1	.....	Yes		Hard C. I. 4 steel segments, 3 m. apart.
30	20 m.	30 m.	4,500	.....	.....	4	.....	1	.....	Yes		Soft C. I. and same with wrot plugs.
31	5 1/2 T.	20 to 24 m.	10 to 14 m.	Every 500 ft.	Not over 2%	1	.....	1	.....	Yes		Note on wheels. Soft C. I. & comp. shoe.
32	10 m.	Abt. 36 m.	1,500	20 per mile	4 to 11%	1	1	.....	.....	Yes		Soft C. I., Hard C. I., C. I. with wood plugs. Wood.
33	1/3 Mo. 16 m	1/3 Trail 6 m	.....	.....	3 to 7%	1	.....	All	.....	Yes		.....
34	1/3 8 to 9 T.	1 to 30 m	Comp. 20 m C.I. 8 to 10 m	Usual in cities.	Max. 3%	2	1	1	.....	Yes		.....
35	8 T.	35 m.	4,500	7 to mile	7%	3	.....	2	Yes	Yes		.....

adjustable on cars, and your men become familiar with their replacement and save time— if you do any one of these a saving results, and if you do two or all, the saving is so much the more increased.

Now, the first step towards an advance in economical operation is to turn to your accounts and records and locate any leaks.

Can you all do this?

I will hazard the statement that you cannot. William Wharton, Jr. & Co., Incorporated, of Philadelphia, in preparing this paper, sent out 300 circular letters and sets of questions for returns—with stamped and addressed envelopes enclosed—to as many representative street railways in the United States.

These were mailed August 18, and up to September 1 thirty-five had been returned—about 12 per cent.

Of the thirty-five answering replies: 7 sent no information whatever (1-7); 7 stated that they had no records of shoes or wheels, but gave such information as memory supplied probably (8-14); 13 gave records of shoes and wheels—“limited,” “not accurate,” etc. (15-26) two had records of wear of wheels, not of shoes (27-29), and 6 had records of shoes and wheels (30-35). Accompanying is a tabulated list of the replies in the order above indicated: [Page 624.]

The small number of these answers first, and the smaller number giving accurate information, second, does not speak well for the interest the members of this Association show in such matters, or the records kept by them. As a whole the replies are very contradictory.

You will note the wide difference in material in use. It is not possible that this difference can exist and all be right.

Who are in error? In my opinion, a standard shape of shoe proper could be put in practical and immediate use. Out of twenty, four circular replies on this point twenty-two favored such a plan. The principal objection made to it is that the hangers wear and will not hold shoes tightly for any length of time. Is not this largely due to faulty design, as the Master Car Builders' Association standard for some years has consisted of a separate shoe and hanger? I am using the word hanger as meaning the clevis in steady railway practice.

The Graham Equipment Company also uses this standard on their trucks, and in a recent letter on the subject they state: “We have no trouble with hangers wearing out. We find they hold the shoes tight, and so far in our experience of three years we have not yet found a case of the hanger or shoe rattling loose.” The Atlantic Avenue Railway Company uses the Master Car Builders' standard, varying the hanger attachment to fit their trucks. The Electric Traction Company, of Philadelphia, the Baltimore City Passenger Railway Company, and many other lines using the McGuire Truck Company's shoe, or designs similar to the Master Car Builders' standard, vary the hanger to fit different trucks. You will find samples of all the above mentioned shoes among those now on exhibition here. I strongly advocate the adoption of the Master Car Builders' standard by this Association, the hangers make to fit our various trucks. In time we may hope to reach a standard hanger, when the brake beam and attachment are made from one design, which could easily be accomplished.

This standard shoe weighs less than any combined shoe and hanger, and most of the metal in it is available for actual wear, leaving the smallest possible percentage of residue for the scrap pile. You will note the great weight of useless metal required for attachment solely which many of the combined shoes and hangers among those exhibited contain.

The standard further requires but one pattern for right and left shoes for all trucks, and car house men become familiar with it and accustomed to its fitting.

Without further attention to shape, I will proceed to some consideration to material. From conclusions based on the foregoing Master Car Builders' report and letters immediately following it, there appears to be three main conditions involved in the “best material,” viz.: that it should be economical in wear itself, economical as regards wear on wheels and should have a good co-efficient of friction. Different men will vary in opinion as to the relative importance of these three conditions.

It seems to be generally conceded that neither chilled iron or steel are advisable, as they have not a sufficiently firm hold on the wheels and wear them too much.

Soft cast iron, on the other hand, is satisfactory on both these points, but wears out too fast. Various combinations of soft and medium hard cast iron, with wrought iron, chilled iron or wooden segments inserted in the frictional face— from 20 per cent to 40 per cent of the

face—have given the best results in all these respects in street railway service so far. The Lappin and Baltimore Car Wheel Companies' shoes represent the soft and chilled segment type; the Composite Brake Shoe Company's shoe the iron and wood segment type, and the Wharton Company's shoe the wrought and cast iron type. Still another type is the Wharton wood shoe, in which the frictional surface consists of oak cut across the grain. The Pennsylvania Railway Company uses a medium hard or soft, if you please, cast iron mixture for its shoes; but it is well to remember that the pressure of the shoe against the wheel, and the circumferential velocity of the wheel is much greater in steam railway practice than in ours, and the former could not use at all, with safety, material which might do our work.

A chilled iron shoe would burn their wheels, and a wooden shoe would be set on fire. Another point of difference in conditions of the two practices is the normal freedom from dirt and grit on the steam track, and the necessary presence of both on all tracks laid in city streets. This grit undoubtedly increases the frictional co-efficient between the wheel and the shoe on street cars, but also tends to increase the grinding of both.

A. Whitney & Sons, wheel manufacturers of Philadelphia, have designed a shoe having open cuts across the frictional face, to permit this grit to fall out. As the area of the frictional face must necessarily be as great as in others of continuous surface, they practically apply a number of small shoes instead of one large one, and the total amount of grit retained by the former type is probably equal to that retained by the latter, so I cannot see any actual difference in result in this respect between the two. The grit is always with us, and must be considered an ineradicable factor in our problem. In connection with the area of frictional surface, the best practice seems to be for the shoe to be not less than twelve inches long, and to rub on both the tread and flange of the wheel.

Regarding this question of material, I have collected the available information, but am free to confess my inability to suggest final conclusions. We must think and work over the matter for a time.

The object of this paper is to call your attention to the value of standard design in the practical business of squeezing dividends out of the operation of your roads; to show you that steam railways have standard shapes for brake shoes and attachments, and that we should and could have our own; to inform you that our roads, as a whole, are inconsistent in their selection of material for brake shoes; and to lay before you for further consideration the facts known regarding the merits of various materials for this purpose.

Too much stress cannot be put on the value of good records in this and other details. The results will more than repay the trouble and book-keeping costs.

The limited time permissible for the preparation of this paper—about three weeks—will make you lenient in criticising its shortcomings.

I now beg to suggest the appointment of a committee to investigate the subject during the coming year, to make experiments, if deemed advisable, and to report at the next convention. A sum of money should, in my opinion, be appropriated by the association for their use. The Master Car Builders' Association is now having a series of experiments made at the works of the Westinghouse Air Brake Company, on brake shoe material.

THE baneful influence of aldermanic pull was illustrated in a recent case in Brooklyn, where a conductor who had been discharged for careless handling of fares succeeded in being hired over again by the same road. He changed his name, put in a big bundle of recommendations endorsed by leading aldermen, and sent another man to the office under the new name to pass examination. Notwithstanding the cleverness of the scheme, it was soon detected and the offender arrested, charged with obtaining employment under false pretenses.

THE convention emphasized as never before the wonderful advance in ideas and capital invested in American street railways during the past ten years. What other industry can approach it?

## MAIL, EXPRESS AND FREIGHT SERVICE ON STREET RAILROADS.

Report read before the American Street Railway Association by  
Richard McCulloch, Electrical Engineer, St. Louis.

Richard McCulloch was born in St. Louis County, Mo., in 1869. He was educated in the public schools of St. Louis, and at Washington University, of that city, at which institution he took the degree of mining engineer in 1891. He was at intervals connected with street railway work in various ways from an early age. After graduation he served six months on the United States Geological Survey in the west. The following year was spent in Mexico as chemist for the Great Mexican National Smelter Company of Monterey. He spent the winters of 1892 and '93 at the factories of the General Electric Company and began active work as electrician of the Cass Avenue and Fair Grounds Railway of St. Louis, in the spring of '93. He was engineer in charge of the construction of the Baden & St. Louis Railway which laid the seven miles of welded track and is now constructing the Southwestern Railway and re-constructing the Citizens' Railway of which thirteen miles is being changed from cable to electricity.



RICHARD MCCULLOCH.

In beginning a discussion of this service it seems necessary to explain that the first word of the subject is spelled with an "i," because a gentleman from the rural districts of Wisconsin proudly wrote in answer to a circular asking for information regarding the carrying of mails, that "his road sometimes carried females too." He desired, however, that all information given should be regarded as confidential, so the name of this most fortunate road is withheld. That the street railroads of this country operate a heavy freight business has long been the opinion of the itinerant tinware peddler, "the umbrellas to mend man," the lady who takes in washing, and all the merchant princes of the tribes of Israel, notwithstanding the fact that a generation of sweet-tempered conductors have talked themselves hoarse in endeavoring to explain matters differently.

The first feature which strikes one in endeavoring to study a subject such as this, is the great difference existing between what are known as street railroads. We have city roads and suburban roads; we have summer resort roads; we have belt roads operated by different motive powers, some of them almost approaching steam railroads. There are large city systems operating over many miles of track and running hundreds of cars, and there is one road down in North Carolina, from which the statement was received that "This here road is owned, directed, managed, superintended and driven by Yours Truly." All these railroads haul different classes of passengers, bent on different errands, and are operated under different conditions. It is manifestly impossible, therefore, to lay down any fixed rule for mail, express or freight service — to say that it should be put into practice on street railroads or that it should not be put into practice. This is a problem which must be solved for each railroad individually. In this paper it is intended merely to give a general discussion of the question without attempting to solve it.

In order to ascertain as well as possible how much has already been done, a circular asking for information in regard to mail, express and freight service was sent to every street railroad company in North America. Nine hundred and seventy-eight letters were sent out and four hundred and five replies were received. These replies are tabulated below. As a great many railroads were not heard from, it can not be assumed that the table is absolutely correct, but it is probable that most of the railroads having such a service answered the circular. Roads which are enumerated as having express or freight services are only those which have this service fully developed. The carrying of packages by conductors of passenger cars was not called express service, but is enumerated in a separate column. From some of the states, notably Pennsylvania, Rhode Island and Massachusetts, it was reported that the transportation of express and freight by street railroads was prohibited by State Law, and many of the roads answered that their franchises allowed only the transportation of passengers.

The rate charged on express matter was usually five or ten cents per package while the freight rates vary from four to ten cents per one hundred pound. The mail is usually carried either under a direct contract with the Government or under a sub-contract with a mail contractor. The income from the transportation of the mails varies according to the amount of mail, the number of trips per day, and the length of the haul, from \$100 to \$1,000 per annum.

	Any form of such service.	Under contract with express company or U. S. Government.	Haul steam R. R. freight cars over street R. R. tracks	Operate special cars for this service.	Carry bundles on passenger cars for pay.	Contemplate such service.	Distribute matter beyond station.	Use combination express and passenger cars
Mail .....	60	51		5		10		
Express .....	35	8		9	31	6	2	7
Freight .....	54		6	36		10	2	

MAIL SERVICE.

That the street railroads of this country are already alive to the possibilities of the mail service is shown by the table. Sixty street railroads are now carrying Uncle Sam's mail, while fifty-one have government contracts. Most of these railways are suburban roads or roads joining towns, but the postal authorities realizing the advantage of quick delivery and collection, are now beginning to make arrangements with the large city systems for transportation of the mails from main postoffices, to branches and for distribution and collection throughout the city.

Various methods of utilizing street railways for this purpose have been proposed by different local postoffice authorities. In one large western city, in which all the roads are controlled by one company, it was proposed to equip one car of each line with a mail receptacle. At stated times, the carriers along the route were to meet this car and drop into the receptacle all the mail collected by them, which was in turn to be taken from the receptacle as the car passed the main postoffice. This plan, however, did not meet with the approval of the great fathers at Washington, and in consequence was abandoned by the local authorities. Any system of this kind would greatly expedite the collection of mails, but the weak point seems to be that no provision is made for their distribution.

The only method of handling a large mail service, in which it is necessary to collect and distribute along the route, and handle it satisfactorily both to the patrons of the road and the postoffice department, seems to be in the use of a separate car, an independent mail car in charge of a railway mail clerk. This system is already in use on street railroads in St. Louis, Brooklyn and several other places, and so far as we can learn is giving excellent satisfaction, both to the railway companies and the postoffice authorities. The mail is quickly and promptly handled, the service is regular and certain, great and small quantities of mail may be collected and distributed with equal facility, the residents along the line are greatly accommodated, and no interruption or inconvenience to the passenger traffic need result.

As an example of such a service, it would probably be interesting to describe the operation of a United States mail car, which has been run by a street railway in St. Louis for some time. The St. Louis and Suburban Railway begins in the business part of the city and runs through the choicest residence and suburban settlements to the town of Florissant, sixteen miles from the center of the city. After leaving the city limits the line penetrates the beautiful Florissant valley, thickly dotted with pleasure resorts, country clubs, summer homes and suburban villas. The down town portion of the road was formerly a cable and the suburban part a narrow gauge steam line, but with the onward march of progress the grip and the locomotive have gone to join the mule car, and the road is now electric throughout its entire length. The mail car makes three trips each day, two through to Florissant and one as far as the city limits. The railroad company furnishes a conductor and motorman, while the postoffice department supplies the mail clerks. The car, which was built especially for this purpose, is equipped with its own motors, and is furnished with the necessary desks, cases, racks for mail bags, etc. At a schedule time it is run up in front of the postoffice and receives the mail put up in pouches from a wagon there to meet it. The mail clerk receives a bag for each station outside the city limits, and for each carrier along the route a bag designated by his number. He also receives all mail which has come in too late for assortment, which is distributed on the car to the proper bags before reaching the first station. Letters are received, cancelled and distributed on this car, just as in the ordinary steam railway mail car. The first stop is at a point about one and a half miles from the postoffice. At this point six carriers meet the car and each carrier receives from the mail clerk

the pouch bearing his number. Another stop is made about two miles out, another two and a half, another three, and another four miles from the postoffice. Any mail for the suburbs is handed to the mail clerk by the carriers and dropped into the proper bag. After the city limits are passed, bags are exchanged at each station just as on a steam railroad. On the return trip the same system is followed until the city limits are reached. Within the city the postoffice department has placed letter-boxes at the principal corners along the line. Each carrier brings the mail collected in his district to the nearest box on the line of the railroad. Stops being made at each box, the mail clerk removes the mail and assort it before arriving at the next station. The letters thus cancelled and assorted are delivered at the main postoffice tied up in bundles ready for shipment. The mail car makes no stops for passengers, and for this reason can easily keep out of the way of the passenger cars. A light freight business is also done on the car. Provisions, light furniture, milk, trunks, etc., are carried and the charges collected by the conductor. The mail service has now been in operation three years. New features are constantly being added to it, and aside from the accommodation afforded the residents of the territory through which the road runs, it is a source of profit to the railroad company.

The system just described seems the best that has yet been devised for the handling of a large mail business. Where the mere carriage of the mails in pouches from the main postoffice to branches, or from depots to postoffices, is undertaken, and there is no attempt made at collection or distribution along the route, there can be no objection to carrying the mail sacks on the front platform, if their number is not too great; but passenger cars should not be stopped and held for mail collections, nor should valuable space within a passenger car be taken up with mail sacks.

The question as to whether or not mail service is called for, depends almost entirely upon local conditions, the length of the road, the territory through which it runs, the proximity of depots and postoffices to the line of the road, and many others. An advantage in estimating the advisability of inaugurating a mail service, is that a certain, fixed income may be assumed, which is not the case with any other service. It is usual in government contracts to pay a certain sum per one hundred pounds per mile, the weight being determined at stated intervals by weighing the mail. For this reason, a certain, fixed income is assured during the interval. A number of cases may be cited in which it would be well for managers to look into the profits which might accrue from a mail service. Large city systems covering various parts of the city, and passing close to postoffices and public buildings would afford great advantages in distributing and collecting the mails. Suburban roads, roads connecting towns, and roads running to depots in the outskirts of the city are other instances of openings for mail service.

An advantage, independent of any financial return, and one which is regarded by many as the one reason for street railways embarking in this service, lies in the prestige of Uncle Sam's name. This point was never so thoroughly illustrated as in the late labor troubles in Chicago. Rioters may have no fear of the city police or of the state militia, both of whom are often entirely in sympathy with them, but they regard, with the greatest awe, a company of regulars armed with Springfield rifles. Uncle Sam will tolerate no interference with the distribution of the mails, and no other point has been so thoroughly impressed upon the dangerous element in our communities during the last year. Some railway managers on securing mail contracts have proposed to paint upon each car, "U. S. Mail," as a kind of official notice that their roads are under the protection of the United States Government. How effective will be the protection against blockades and riots, and how great a moral influence this will exert to prevent strikes and other stoppages remains to be seen.

#### EXPRESS AND FREIGHT SERVICE.

The answers to the circulars showed that thirty-five roads are now engaged in the express business, while fifty-four are hauling freight. As a matter of fact, however, few roads through the country are doing a regular freight business, most of the so-called freight services partaking more of the nature of express. As operated upon street railways the distinction between express and light freight service is so ill-defined that it is deemed best to consider both subjects together.

There are many points in the street railroad as now conducted which make it almost an ideal agent for the transportation of packages and light freight. The great number of points reached by the cars, the absolute certainty with which they run, the thousand and one precautions taken against any stoppage of however short a duration, the rapidity with which distant points are reached and many other causes combine to make the street railroad of to-day a common carrier of exceptional

advantages, when only short distances are considered. Many conditions will suggest themselves to railway managers in which an express or freight service may be made a paying institution. In the case of a town in which the railway station is some distance from the business part of the town, there can be no quicker, safer and better plan of conveying express and freight to some distant point in the heart of the town, than by the street railroad. Whether or not this will pay, depends upon the amount of material, the competition, the distance, and the scope of the street railway franchise. A case often met with through the country is that of two towns connected by an electric railroad, one of which, having no steam railroad, is obliged to get all its supplies through the other town. The installation of a freight service of some kind would at once suggest itself in this case, and the profits would depend upon the size of the town, the character and occupation of the inhabitants, the distance between the towns, etc.

The operation of an express service on large city systems has not been attempted to any great extent, but it has been contended by some enthusiasts on the subject, that a street car express service will eventually take the place of the many city deliveries and city express wagons now in use. As an example of a city road operating an express and freight service involving collection and a house to house delivery, it would be interesting to cite the case of the Southern Railway of St. Louis, which has been operating an express service on this plan for almost two years. The Southern Electric Railway begins in the heart of the city and runs in a southerly direction for seven miles, following the general direction of the river to Carondelet. The territory penetrated is thickly settled for almost the entire distance and in no essential does the road differ from the ordinary city street railway. Three trips per day are made upon schedule time by the express car, which is entirely independent, being mounted upon motors of its own. At the down town end is a receiving station where a clerk receives all express consigned to the company and keeps all the books pertaining to the service. The especial feature of this service, however, is the collection and delivery. This is effected by means of wagons, two of which are kept at the down-town end of the road, and three of which meet the car on all trips at certain points along the line. On receiving notice by mail, telephone, or otherwise, a wagon calls for a package, delivers it at the car, from which it is handed to the proper wagon, and delivered to the address marked on the package. A charge of ten cents per package is made for this delivery, and trunks are taken from houses to the Union Depot, checked, and checks returned, for the sum of fifty cents. A corresponding charge according to size is made for the delivery of large boxes and bundles. A compliment to the efficiency of the service is paid by the large dry goods and clothing houses, who have ceased to run their delivery wagons into this part of the city and now consign all of their bundles to the railroad company. Where formerly one delivery daily was made by the wagons, three are now made by the railway. An interesting feature of the service is that several large factories located in the southern part of the city consign all their freight to the Electric Express. The goods are put on the car, taken to the proper railroad stations, shipped, and the bill of lading returned to the consignor. Packages are received by the express car C. O. D., the charges collected, credited to the proper account, and settlements made at the end of each month. The railway company assumes all the responsibilities of a common carrier, holding itself liable for all loss and damage. This, however, is a contingency which seldom occurs. The service has now been in operation for about two years. It is well patronized both by the residents along the line, and the large retail stores in the center of the city. It does not interfere with the regular running of the cars, and since its inauguration has never failed to pay.

Up to this point we have considered an express and freight service merely as a paying or non-paying institution, to be adopted in the one case and to be rejected in the other. There is another view which may be taken of the case, however, which is in many instances the most proper solution of the problem. This is to regard the establishment of this service merely as an auxiliary to the passenger traffic, to be operated whether or not it pays, in order to gain increased passenger travel. The most notable instances of this sort are the roads which run from the hearts of our large cities out into the suburbs. It is manifestly to the interest of these roads to promote building and settlement along their lines, and how can they better attract builders than by giving their patrons all the advantage of city life—not only in furnishing them with rapid transportation to and from the city, but in aiding them in receiving their provisions and supplies. This calls for some form of express service, and although the receipts from this source may not equal the expenses, the increased passenger receipts and the advertisement given the road must also be taken into account.

In all street railroad practice, the cardinal point of any service, whether mail, freight or express, must be that it does not interfere in the least with the passenger travel, and this point should always be kept in view in the arrangement of such a service. For this reason, we would strongly advocate the use of separate cars, operated by separate motive power and by separate men. In roads between towns, or suburban roads operated on the same plan as a steam railroad, where stops are made only at certain stations, a combination car or a trailer might be used; but in city roads the system of piling trunks and boxes in the passenger cars and on the front platform, and stopping for these to be put on and taken off, is not of the era of the electric railway. Another system, more fitted to the mule and the bobtail, is the custom, yet in vogue in some places, of receiving small packages for transportation and allowing the conductor to deliver them along the route, stopping the car and forcing the passengers to wait. If the addition of a package service renders necessary such a reduction in the efficiency of the passenger service, it is difficult to perceive the gain in accommodation. A passenger car should carry passengers; it should stop and start for passengers alone, and it should reach the end of the road in the shortest possible time.

If mail bags may be thrown on the front platform of a car, carried to their destination and delivered without causing any long stops, this is perhaps the best way of solving a mail service on a small scale, but in a freight or express service it is better that the work should be done with cars especially devoted to such service and by men especially trained for it. A single box car equipped with motors of its own will handle the light freight and express of quite a territory without any interference with the regular running of cars. A twenty-five foot car, equipped with double trucks, supplied with the most approved form of motors and controllers, and fitted up either as a mail car, express car, or combination car, can now be obtained for two thousand to twenty-five hundred dollars. A smaller car mounted on a single truck can be obtained for less money. If heavy freight is to be hauled, it should be carried in motor and trailer cars built especially for this purpose.

If it is proposed to establish a freight or express service, estimates should be made of the amount of business which could be procured, of its reliability, and of the rates which could be charged, taking into account the existing competition. On the other side, the cost of operating such a service should be estimated, allowing liberally for the time the investment is in idleness on account of nothing to do. If a reasonable assurance cannot be obtained of a steady and regular traffic, it is best not to venture into it, for an unreliable trade is liable soon to develop into a losing one. There are cases, however, as has already been pointed out, when it would be good policy to operate such a service at a loss, merely to give accommodation to patrons, and it is possible that a service started for this purpose alone might in a growing community develop into a paying one.

Before leaving the subject of express service, it might not be out of place to give a brief description of a novel form soon to be introduced upon the Union Depot Railroad of St. Louis, in which the freight is to consist of members of the genus homo in a more or less disjointed state. This great railroad system in its ramifications extends to almost all parts of the city, passing nearly all of the city institutions, including the dispensary, city hospital, and several of the other hospitals, and at the desire of the city authorities it is now having built a hospital car. As designed, it is a twenty-five foot body, double truck car, having a double floor filled with asbestos to deaden sound. It is proposed to utilize it primarily in conveying patients from the dispensary to the city and other hospitals. It can also be used in case of a great fire or calamity in which there are many injured, and where the horse ambulances are not capable of handling the work. It is expected that other uses will develop for it after being put into service. The car is to be equipped with stretchers, folding chairs, a tank of water, apparatus for heating water by electricity, an emergency drug store, dressings, instruments, earth closets and all necessary apparatus for taking care of the sick and injured. A surgeon is to be in charge of the car and will accompany it on all its trips. The car is now being built, and the innovation will, no doubt, be watched with a great deal of interest. It is intended by the city authorities to make arrangements to run the car over all the electric tracks in the city, as this will enable them to reach almost any point within the city limits.

Information received from several of the states, as before stated, shows that in some places, the transportation of freight or express over street railroad tracks is prohibited by State Law or municipal ordinance, and it has been suggested that associations of managers of street railroads in those states be formed for the purpose of securing favorable legislation. The enactment of these laws may be due to hostile steam rail-

road influence, or it may be due to a misconception of the nature of the services which street railroads would put in operation. Surely, a smoothly running electric car, moving swiftly onward would not prove such a nuisance as the great lumbering wagons which block the streets of our large cities. Where a freight or express service is needed, the accommodation to the public would be so great that many citizens might be enlisted on the side of the railroads to secure the proper legislation.

In closing, it would perhaps be well to note some of the principal points which, it is hoped, have been brought out in this paper:

- (1) That a mail service involving collection and distribution is best handled on a separate car, operated on the same plan as a United States Railway Mail Car.
- (2) That it is supposed that a great advantage arising from the transportation of the mails, comes from the fact that the road is under the protection of the government, and is thus secure from riots, strikes and blockades.
- (3) That the most promising opening for an express or freight service is a road running between two towns, or a city road running through well-populated suburbs.
- (4) That the question, whether or not such a service will pay, is entirely a local question, and must be estimated for each road separately, under existing conditions.
- (5) That there are cases when it would be advisable to operate such a service, independent of the profits, in order to accommodate the patrons of the road and to induce building along the line of the road.
- (6) That such a service operated upon the ordinary street railroad must not be allowed to interfere in the least with the passenger traffic.
- (7) That in States having laws prohibiting this service, associations of railway managers should be formed to secure favorable legislation.

Five years ago, such an institution as mail, freight or express service on street railroads would not have been thought possible. Such a service has always been considered as a prerogative of the steam railroad, and the fact that some street railroads have already gone into this business and that many others are engaged in investigating its merits, goes to show how eagerly the street railroad is encroaching on the domains of its elder brother. And it is not only in this respect that the electric railway is pushing the steam railroad. Belt lines, suburban lines, dummy lines, summer resort roads, mining roads, and many others, are rapidly being converted to the electric system. Everywhere we see instances of the screech of the locomotive being hushed by the busy hum of the trolley. We peer into the darkness of the future and we see great systems of railroads operated by power houses located in the neighboring coal fields; we see the great cities connected by electric lines, operated at marvelous speed, and perhaps at no distant date will some new "Empire State Express," or "999 Limited," be pointed out as the development of the electric street railroad.

---

## CURES RHEUMATISM.

---

There is a belief on the part of many persons that riding in trolley cars will cure rheumatism. They say that there is a certain influence obtained by watching the rails from a front seat in the car as they appear to grow shorter. Europeans are gravely discussing the effects of electric railways on rheumatism. In order to obtain the benefits of the cure the patient must keep one eye on the motor and the other on the trolley.

---

## ELECTRICITY IN ROAD BUILDING.

---

During the construction of a branch of the Citizens' Traction Company, Pittsburg, the contractor hit upon a method of using electric power to save time. There was considerable filling required, so a temporary track was laid, trolley wires strung, and a motor car and ordinary flat car pressed into service. He found that the car saved the hire of several teams, several men, and a great deal of time. The idea can be put in practice in other places.

## PASSES.

### How They Are Managed by Various Street Railways—The Card Pass—The Coupon Pass—The Best System.

From time to time requests come to the REVIEW from its readers for information in general or particular, as to certain phases of street railway work not down "in the books." One of these requests has been regarding passes, complimentary or employe's. The latter are ordinarily considered a necessity, while the former—well, they are not exactly a necessity, but usually the Street Railway Company is either bulldozed or persuaded into granting them.

We may preface the whole affair by the statement that the best pass is no pass, just as the best Indian is a dead Indian.

Granting, however, that in most cases passes are of necessity a part of the routine of a street railway, they should be discussed and the general consensus of opinion gained, if possible, in regard to their use.

Passes may be divided into four general classes:

1. Complimentaries to officials whose good will is necessary to the smooth running of the road and the interests of the patrons' peace and pleasure. In this class may be rated the favors to the city fathers, the police and fire departments, newspapers and the like. Mail carriers are allowed a government stipend for street railway fare, and unless specified by franchise are not ordinarily carried free.
2. Officers of the road, stockholders and semi-official clerks.
3. Employes of the line and shops, stable, etc., traveling to and from duty.
4. Visitors and occasional favors for particular favors rendered.

IN ST. LOUIS.

Secretary C. N. Duffy, of the Cass Avenue and Fair Grounds Railway Company, operating the Northern Central Railway, the Cass Avenue and Fair Grounds Railway, the Union Railway and the Citizens' Railway, sends specimens of the passes used on that system.

They are broadly employe's badges and complimentaries issued to directors and officials of the road. This is called an official pass, and a specimen is shown in our engraving No. 0 108. It is sometimes issued to others not occupying official position, but no passes are known as complimentaries. All conductors are instructed to accept this unconditionally by whomsoever presented. It is customary for the person presenting this pass to also tear out transportation for any one for whom he wishes transportation that may accompany him. These passes are confined to a limited number of persons.

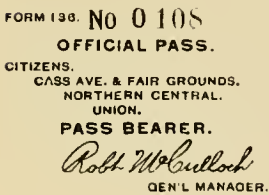

Another form of pass put up in books of 300 is shown also. It is number 368. As to this form, Mr. Duffy says:

"The conditions of the use of this style of pass are very plainly expressed, and we endeavor to have these conditions lived up to, but our experience has been that it is extremely difficult to have this done, as the general practice is, especially where the owner of the pass book is known to the conductor of the car, that the owner detach the pass, and not the conductor, notwithstanding the printed conditions on each pass. These conditions we cannot very well control, except to discipline the conductor for violating his instructions, but we can and do control the use of the pass book in the sense that it is not good for transportation except when presented by the party to whom it is issued."

This style is used by superintendents, foremen and heads of departments, members of the detective force of the city police and special officers in citizen's clothes. In St. Louis, firemen and policemen in uniform are carried free. This pass is issued only to members of the police department living on the lines of the system, and each donee is limited to four books a year.

By having each pass numbered, it is possible to tell to some extent whether or no the privilege has been abused. For instance, if two coupons of No. 368 are turned in by a conductor on one trip, the employe is disciplined and the owner of the book blackballed.

In accounting for the passes, two ledgers are kept: one for the official and another for the other form. The pages of the ledgers are numbered to correspond with the numbers on the passes. When holder of official pass 108 takes his hook he is debited with it on page 108 of the official ledger; when the empty cover is returned he is credited with it and a new one issued. One very remarkable thing about the passitem on the Cass avenue and Fair Grounds is the small number of these in use. Mr. Duffy finds that for June, 1894, that the whole number of passengers carried on passes was  $\frac{146}{10000}$  per cent of the total (00.146 per cent)! Some pass ridden managers will envy the Cass avenue line its immunity from this form of street railway misery.

In relation to the improvement in form and method of issuing passes, Mr. Duffy says: This matter is governed altogether by the individual conditions encountered on each road, and, whilst it is no doubt true our own forms could be improved upon, as a general proposition we are opposed to changes, and I do not know of any special disadvantage in the use of our passes, or any special

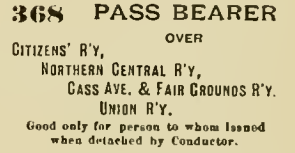
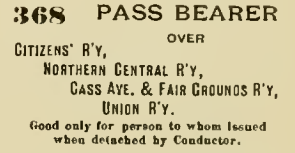
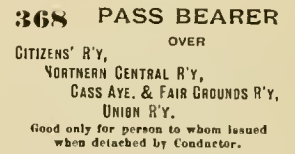

advantage to be gained in making a change. If I were to follow out my own desires in the matter, I would not under any circumstances issue any kind of pass to any one, either connected with the road or not connected with the road, and I would gladly pay my fare every time I ride on our own cars if we would be enabled to abolish all passes.

The Secretary and Treasurer of the Newark Passenger Railway Company, Newark, N. J., outlines the best system in vogue anywhere in the world. He says: "On January 1st, 1894, this company discontinued the use of passes of all kinds." Happy Newark.

#### THE LOUISVILLE RAILWAY COMPANY,

of Louisville, Ky., thinks that simplicity is the main object in the matter of passes, and use as few as possible, and incur them as little as possible, with regulations. Firemen and police in uniform or with badges are passed at all hours. In cases where newspaper men, directors, and others are complimented they are given blue celluloid tokens representing 5 cent fares. These amounts are charged to "Gratuities" account in expenses.

During school months pupils and teachers are allowed a half-fare, 2½ cents. The token used is a round copper piece the size of a nickel, with a square hole in it. The persons purchasing same must present certificate showing that he or she is a teacher or pupil, together with location of the school, together with the particular line of railway to be used. The time of this ticket is limited to the usual period of going to or returning from school, and only during the school year.

Laborers are furnished daily with yellow or black celluloid tokens, good for passage to and from their homes and places of work on the street railway lines. They are distributed daily by authorized foremen, and strict watch is kept to avoid abusing the privilege. The general officers and their clerks are passed free at all times and on all lines by depositing a red celluloid token. Where transfers are to be taken, a round brass token, like a ring, is used. Directors use either the red token as mentioned or a paper ticket bound in book form. In case of picnics or like excursions a special paper ticket is used. They are issued in quantities to the proper authority of the picnic or excursion at a stipulated rate, according to quantity and distance. These are strictly accounted for on date issued.

#### THE OAKLAND, SAN LEANDRO AND HAYWARD'S ELECTRIC RAILWAY,

of Oakland, Cal., has a superintendent who had at one time sad experience with the pass. His name is Frank M. Leland, and his system is now the acme of simplicity, neatness and dispatch. Mr. Leland says:

"Before starting this road I was connected with some other roads, where the pass system was so extensive as to take in almost any one who felt inclined to ask for the favor. I also noticed that people riding on passes generally expected to occupy the best seats in the car, and

some would even kick at the trouble of showing their passes, and, when by chance they left them at home and struck a strange conductor, they kicked loud and long if they had to pay fare. So when starting this road I ask the officials to try a new way, viz: To not issue passes to any one, and it has worked so well that it is still in force. Would also say that should I ever leave this road and take charge of another I should by all means recommend that the same course be pursued."

The officers of the company ride on unnumbered badges and rule 10 of the rule book is enforced to the letter. It reads:

**RULE 10—WHO RIDE FREE.**—Conductors will pass only the following persons: President, vice-president, secretary, treasurer, attorneys and directors of the company, superintendent and assistant superintendent and all the company's employes when wearing a numbered badge; constables, policemen, town marshals, when on duty in their respective towns; visiting officials of other roads, when in company with an official of this road; ex-employes, when going to secretary's office for deposit if in possession of superintendent's order for same; new employes, when going to make deposit if in possession of superintendent's order to make same; new employes coming from secretary's office with deposit receipt, and no others. Conductors must put down names or number of each person so carried on his trip sheet. If motor-man or conductor, put M. or C. with number; if other employe, number alone.

#### THE SECRETARY

of a prominent Street Railway Company, whose name we forbear to mention, says:

"We are not at all satisfied with our pass system, and would not want any street railway company to say we do so and so. We do issue card passes, and it is a most pernicious practice. We have out between 300 and 400 altogether. The proportion of passes issued to our immense traffic is not so great but that we can afford it, but our way of accomplishing it is very bad. Passengers get in the habit of simply calling their pass numbers to the conductor, and conductors may compel presentation of pass if necessary. The chances are, however, that the conductor doesn't require ocular proof. So very soon after new issues conductors simply pass pass carriers and say nothing, pretending to make an entry on the trip slip. This makes it almost impossible for secret service men to check up the lines. It is my opinion that the only pass should be the coupon pass, so that the conductor may be compelled to show cause for the transportation of every passenger in his car."

#### ON ACCOUNT OF POLITENESS.

"Papa," said Johnny Snaggs. "Well, Johnny?" "What is a miracle, papa?" "Well, Johnny, it is a miracle when I get a seat in the street car.—Pittsburg Chronicle-Telegraph.



## FROM THE DAILY PRESS.

A Few Choice Selections Containing Valuable Information for Review Readers.

If there is anything more amusing under the sun to the technical man than the attempts of the daily press to deal with technical matters it is yet to be discovered. The efforts of a woman to drive a nail are tame sport as compared to the attempts of the average reporter to discourse on electrical and mechanical phenomena.

One of the most important events is the discovery of perpetual motion by two Bay City, Mich., mechanics. The press dispatches read:

BAY CITY, Aug. 20.—Two machinists in this city have patented an air motor, which they claim will revolutionize street railway traffic. The machine operates by suction, and all that is necessary to start it is to pump air into the cylinders when it will continue to run without stopping, replenishing the air in the cylinders with its own motion. The inventors claim to have a complete machine ready for operation, and place a high value on the patents.

Another startling accident was caused by the "exploding" of an electric motor on the line of the Twin City Rapid Transit Company, at St. Paul. Verily, the possibilities of the deadly trolley are as yet undiscovered! A few years ago the motors were not known to do anything worse than buck. The St. Paul Globe, under the scare head "Street Car Explodes," says:

At 2:15 yesterday afternoon a motor exploded on Grand Avenue Car No. 613, while the car was passing the corner of West Fifth and Seventh streets. Adolph Feise, the well-known drum major, was thrown from the car. \* \* \* Mr. Feise was at his usual place of business last night and did not show any serious results from his experience with chained lightning.

The following is the mishap which occurred to a southern road, as related by a local paper:

Last night, the cylinder heads of one of the dynamos of the Electric Railway Company was blown out. The engineer had a very narrow escape from being hit by a large piece of iron, which would have killed him. A conductor by the name of Young, who ran to one of the cars to escape, was given a pretty bad shock. The schedule was badly broken into.

Street railroading has made wonderful progress in the last few years, and it is now reduced to such a fine point that street railways can be made to order and guaranteed to fit. An Ohio paper comments on the situation as follows:

Will P— is in Hicksville, Monday, measuring the town for a street railway. The line will extend from the depot to the fair grounds and cemetery. It is not known that a street railroad is contemplated. Mr. P— is working for a company that is measuring towns and making estimates of the cost of such lines. Mr. P— measured Napoleon, Wednesday, and then went to Warsaw, Ind., and Urbana, Ohio, and measured those towns.

An editor in a small city, on returning from an excursion to Cleveland, had among other notes of the trip:

The fact was remarked that Cleveland's street railroad lines are equipped with larger sized trolley wires than our own line uses. The cars were more frequently too.

The scientific columns of the lay press abound in hidden gems of information, of which the following is a fair specimen:

When electric motors were first applied to cars grave doubts were entertained as to the resultant effects of the extreme jarring on the

poles of the field magnet, in the light of the knowledge that a permanent magnet loses its magnetization by jarring. The law of compensation seems to abound in nature, since it is now proven that the field magnets, which are not permanent magnets, increase in magnetization by the jarring to which they are subjected.

We doubt if Dr. Wilson would recognize his motor truck from the following description, which was sent out by a Tyrone, Pa., correspondent:

An improved electric motor truck has been invented by Dr. James T. Wilson, of Tyrone, which threatens to revolutionize the present street car and in many cases take the place of steam motors. It is on the storage battery system, and can be made from one ounce power up to a hundred horse power if necessary. For street car purposes two motors would be sufficient to make a speed of thirteen miles an hour, although that speed could readily be increased.

A street railroad man, in New Jersey, was interviewed last winter on the subject of electric heaters. We are sorry for him, as he has evidently been misquoted. At least he gives utterance to some very peculiar notions through the medium of the reporter:

"I would like to have the electric cars heated this winter," he said, "and it may be possible that we will, if the expense is not too much. Car No. 108 is heated by a storage battery in the car, which gets its power from our current. A continuous circuit of copper wire encased in a cast iron pipe runs underneath the seats of the car and the heat from the pipe warms the car. At one time yesterday the thermometer reached 80 degrees in the car. The faster the car glides over the tracks the higher the thermometer gets."

Here is an item in which the laugh seems to be on the other side. It is from a Pacific coast paper:

The flat wheels of the Vernon street cars make such a noise and jar that all the fruit is knocked off the trees. This saves the expense of picking fruit, as well as shaking up the livers of the patrons of the road.

## BLOWS HOT AND COLD.

A car has been assigned and will be put in service in Philadelphia intended to afford at once an open and closed car on the same wheels. Combinations are already in

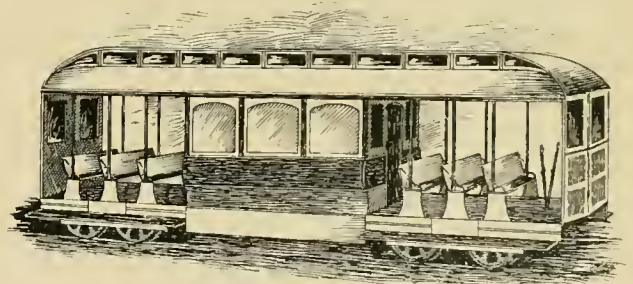

use in many places where one end was closed and the balance open. This design places the enclosed portion in the center of the car and is readily explained by the illustration.

THE suit brought by the Edison Electric Light Company against Westinghouse, Church, Kerr & Company, for infringement of the feeder and main patent, has been decided in favor of the defendant by Judge Acheson, of the United States Circuit Court of Appeals, at Philadelphia.

## THE BROTHER-IN-LAW.

BY A WESTERN MANAGER.

The dishonest street railway conductor, who is anxious to share in the earnings of the company for which he is working, often resorts to many an ingenious way for accomplishing his purpose.

A device which has been used to some extent, but invariably with poor success, for defrauding street railway companies using the portable register, is what is known in street railway vernacular as the "brother-in-law." They are likened unto the plague, generally making their appearance at irregular intervals in the possession of the "professional" conductor, who is as migratory as the duck, and always resulting in the discharge of a number of conductors who are led to believe that with its aid they can increase their daily earnings to such an extent as to make them independent of a railway

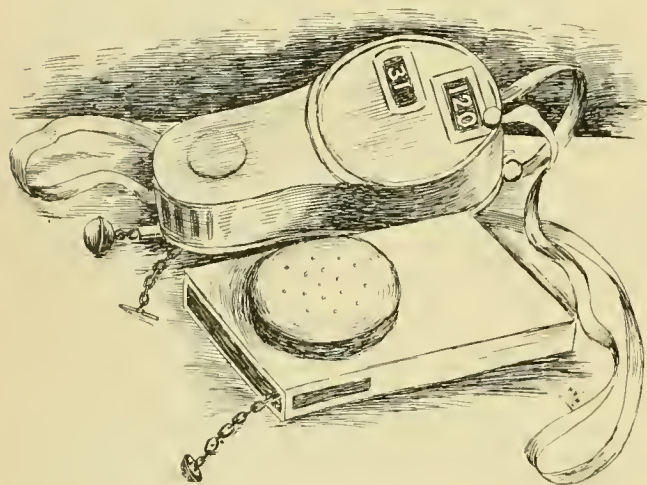

THE BROTHER-IN-LAW

corporation. The "brother-in-law" is not protected by patents, and when introduced by the professional conductor is usually taken to some tinker and locksmith whose experience extends to the filing of keys for manufacture and turned out in such quantities as to satisfy the demand. The illustration shows the register accompanied by its "brother-in-law," which is the latest improvement of its kind in my experience. It is constructed of brass about three inches wide, five inches long and nearly an inch in thickness. It has a bell on the inside taken from a small sized alarm clock, which is sounded by pulling a short chain. This "brother-in-law" is worn inside the vest, suspended by a strap or elastic band around the neck, and is invariably accompanied by the regulation register.

The conductor provided with the "brother-in-law" pulls the chain to which is attached a button or knob, thus ringing for the fare, but not registering it. The button is ordinarily thrust through the vest button hole and resembles an ordinary vest button.

It is generally used at night, when the cars are crowded, or at other times when the conditions are most favorable.

There are many different varieties of these "brothers," all constructed for accomplishing the same purpose. An old watch case with a bell inside is sometimes used for the purpose and is operated in the palm of the hand. It does not, however, take the average conductor who invests his money in one of these machines long to find out that he has made a very poor investment, for detection is almost certain. He will, as a general rule, lose his "nerve" before even attempting to use it, and leaves it to the use of his more professional brother who is more hardened in the ways that are dark.

## LOTS OF IT COMING.

Lectricity is comin',  
 We will git it through a slot;  
 'Twill take ye in the street cars  
 Quick ez steam ez like ez not.  
 It's ez fine a style o' travel  
 Ez ye ever come across,  
 An' it means a good vacation  
 Fur the ole gray hoss.

How often hev ye seen him  
 Trudgin' slowly up the hill,  
 Whiles' the kerridge steeds went by him  
 Harnessed up jes' fit ter kill;  
 Never stoppin' ter look sidewise,  
 Nor ter give his head a toss;  
 He hez stuck right down ter duty,  
 Hez the old gray hoss.

Ere long perhaps they'll sell 'im  
 Ter do chores around the farm,  
 Where the roads is sof' ter travel  
 An' the breeze ain' none too warm.  
 So bring on yer apparatus;  
 It won't cause yer any loss,  
 An' it means a good vacation  
 Fur the old gray hoss.

—Washington Star.

## HAD A HEAP TO LEARN.

He was a new man and ran a car for his third or fourth trip down South State street. He, moreover, was highly susceptible to the charms of two pretty shop girls who were his most interesting passengers. In the middle of the car sat an elderly and rather stout colored woman who suddenly arose, jerked the bell, and waited for the car to stop. "Please, let that rope alone, madam," said the new conductor, sharply. "Will you haf de kin'ness den, sah, to 'tend to yo' own biznis, so dat a lady can get off'n de cah when she so desiah, sah, wid out de truble of ringing dis bell he'self. La chile, I was er 'libe fo' yo' was bohn en I tells yo, yo'se got a heap to learn yit 'bout how to treat ladies. I rid in cahs foh yo' ebah gib up yo' nursin' bottle and I knows de juties of yo' to de ladies. Good bye, boy, I gits off heah!" and she disappeared, the broad smiles of the two pretty shop girls following the conductor like an avenging spirit.

"IS NOT A DYNAMO A RESERVOIR?" asked a reporter the other day. "Yes," was the reply; "it's a kind of boiling tank to keep the electricity hot."

## TIME TABLES AND TRAIN SCHEDULE.

### PART III.

The preceding articles upon this important subject have clearly indicated the broader rules upon which time tables are to be founded and the main exceptions to the rule. We have, however, to present this time a few distinctive methods pursued by managers to regulate traffic. The first is from C. A. Denman, superintendent of the Toledo, O., Consolidated Street Railway Company. Mr. Denman has the following formula from which he deduces the "time":

Take the length of the line in feet, divide by number

Take run number 1 and compute through the day on a 56-minute schedule, and start run number 2 as many minutes later as the interval may demand. The Consolidated has a satisfactory train service and operates 80 motor cars and 40 trailers.

### MILWAUKEE'S CONSOLIDATED

lines of the Milwaukee Street Railway Company are numerous, and the skill required to devise running time for all of them is considerable. Manager C. D. Wyman, whose experience cannot be gainsaid, sends us the following remarks on the matter of schedules in general:

"The formula which I have used in making time-

## WALBRIDGE PARK AND CHERRY STREET.

### No. 1.

7-2-94	Leave Walbridge Park.	Orchard St.	Arrive at Monroe Street.	Arrive at Bancroft Street.	Arr. & Lve. West Toledo.	Arrive at Bancroft Street.	Arrive at Monroe Street.	Arrive at Orchard Street.
	4 44	4 58	5 10	5 26	5 42	5 54	6 08	
6 16	6 24	6 38	6 50	7 06	7 22	7 34	7 48	
7 56	8 04	8 18	8 30	8 46	9 02	9 14	9 28	
9 36	9 44	9 58	10 10	10 26	10 42	10 54	11 08	
11 16	11 24	11 38	11 50	12 06	12 22	12 34	12 48	
12 56	1 04	1 18	1 30	1 46	2 02	2 14	2 28	
2 36	2 44	2 58	3 10	3 26	3 42	3 54	4 08	
4 16	4 24	4 38	4 50	5 06	5 22	5 34	5 48	
5 56	6 04	6 18	6 30	6 46	7 02	7 14	7 28	
7 36	7 44	7 58	8 10	8 26	8 42	8 54	9 08	
9 16	9 24	9 38	9 50	10 06	10 22	10 34	10 48	
10 56	11 04							

## WALBRIDGE PARK AND CHERRY STREET.

### No. 2.

7-2-94	Leave Walbridge Park.	Orchard St.	Arrive at Monroe Street.	Arrive at Bancroft Street.	Arr. & Lve. West Toledo.	Arrive at Bancroft Street.	Arrive at Monroe Street.	Arrive at Orchard Street.
	4 54	5 08	5 20	5 36	5 52	6 04	6 18	
6 26	6 34	6 48	7 00	7 16	7 32	7 44	7 58	
8 06	8 14	8 28	8 40	8 56	9 12	9 24	9 38	
9 46	9 54	10 08	10 20	10 36	10 52	11 04	11 18	
11 26	11 34	11 48	12 00	12 16	12 32	12 44	12 58	
1 06	1 14	1 28	1 40	1 56	2 12	2 24	2 38	
2 46	2 54	3 08	3 20	3 36	3 52	4 04	4 18	
4 26	4 34	4 48	5 00	5 16	5 32	5 44	5 58	
6 06	6 14	6 28	6 40	6 56	7 12	7 24	7 38	
7 46	7 54	8 08	8 20	8 36	8 52	9 04	9 18	
9 26	9 34	9 48	10 00	10 16	10 32	10 44	10 58	
11 06	11 14							

of minutes it takes to run the entire length of the line, which will give the number of feet run per minute; multiply by 60, which will give the number of feet run per hour; divide by 5280, which will give the miles per hour. The formula may be expressed:

F

$$- \times 60 \div 5280 = \text{miles run per hour.}$$

M

The two time tables presented, number 1 and number 2, show the method pursued by Mr. Denman. Let one round trip consume 56 minutes, divide that by the number of cars run, which gives the interval between cars.

tables for some years is an old one, but it may be strange to some of your readers. It is as follows:

$$60 \times \text{miles of track.}$$

$$\text{-----} = \text{No. of cars.}$$

$$\text{Speed per hour} \times \text{headway per minute.}$$

Using this formula, the number of cars to be run on any line at any desired headway can be readily ascertained, and this once done due allowances for swings and lay-offs can be introduced. Our rate here is figured at ten miles per hour., which is an averaged rate of six miles in the center of the city and fourteen miles outside of the business precincts."

## MILWAUKEE STREET RAILWAY CO.

# GENERAL SUPERINTENDENT'S REPORT

OF OPERATION FOR *Tuesday* THE *25<sup>th</sup>* DAY OF *July* 18 *94*.

LINE	CARS				LINE	CARS			
	REGULAR	EXTRA	MINUTES	HEADWAY		REGULAR	EXTRA	MINUTES	HEADWAY
National Ave. and Walnut St	22	CARS	5	"	Vliet St.	5	CARS	10	"
Greenfield Ave. and Third St	18	"	5	"	Wisconsin and Twelfth Sts	8	"	8	"
Muskego Ave. and Center St	12	"	9	"	Wisconsin and Wells Sts	7	"	8	"
Broadway and Chestnut St	8	"	6	"	Wisconsin St. and Merrill Park	7	"	8	"
Russell Ave. and Holtan St	16	"	7	"	Wisconsin and State Sts	8	"	8	"
Farwell Ave. and Union Depot	12	"	5	"	Clybourn St	2	"	15	"
Mitchell St. and Cambridge Ave	10	"	10	"	Whitefish Bay	2	TRAINS	30	"
North Ave. and Lakeside Park	4	"	16	"	Wauwatosa	4	"	25	"
Howell Ave.	2	"	20	"	National Ave. Extension	1	"	15	"

(Closed, black)  
(Open, red)

TOTAL

TOTAL

GRAND TOTAL.



Superintendent George W. Jewell, in whose hands the time tables are placed, uses a general schedule as shown in our engraving. This gives the number of cars on each line and the headway. A separate week day and Sunday schedule is in vogue.

All time tables are so arranged that the men are given their time for the trip from one end of the line to the other, so many minutes for the round trip. In addition to that, points are designated along the line, varying from 5 to 10 minutes, where the running time may be corrected. On the line, inspectors are employed whose duty it is to see that the cars are kept on "schedule." The conductors are paid by the hour, as are motormen also, and train crews are held strictly responsible for both time and accidents. At the present time there are in use on the system 148 regular cars, besides 30 extras daily. The transfers in Milwaukee are made both by conductors and by transfer men, the former carrying yellow tickets and the latter red ones. There are seven different car stations, with a foreman for each.

The specimen table presented is on the National avenue line, running twenty-two cars. The cars are housed at each end of the line, and are consequently started at each end at the same time, and are pulled into house at night in the same manner. The headway on this table is six minutes.

The time for the cars runs across the table, and the word "end" means the terminus of the line and the time of arrival at or departure from the same. The stars denote the relief time when the "swings" come on to relieve the regulars for meals. The schedule is otherwise self explanatory, and works well on the Milwaukee system.

THE CITIZENS' TRACTION COMPANY, of Pittsburg, under the efficient and economical management of J. E. Rugg, superintendent, gives excellent service. Mr. Rugg gives the following general rules as governing his procedure:

"First: Have as little lay-over time as possible.

"Second: Meet the requirements of traffic. Carelessly made schedules are likely to be expensive ones, therefore, the man in charge of this work should be carefully selected with a view to his special fitness for the place." Mr. Rugg advocates special Sunday, holiday and Saturday schedules, as well as fair and stormy weather time cards. As to computing headway, he uses the half-trip sheets, as is the practice of Mr. Jewell, of the Chicago City Railway. In relation to the rush trip, he says:

"It is usual to bunch the cars as much as possible to meet the rush travel morning and evening, or at any other time of day occasion may require, but it is not wise to allow too long a time to elapse between cars even if the volume of traffic is not large."

We show herewith a specimen time table of the Citizens' Company on East Liberty street. It is a week-day schedule, cable line, with 10 straight day runs, 16 straight night runs and 10 swings and 10 trippers, in all 36 cars with 46 crews, 361 trips and 3,610 miles run.

## THE LALLA ROOKH OF THE TORONTO AND SCARBORO.

A new departure in street car building has been made by the Toronto & Scarboro Electric Railway, which is proving very popular with the public. The specifica-

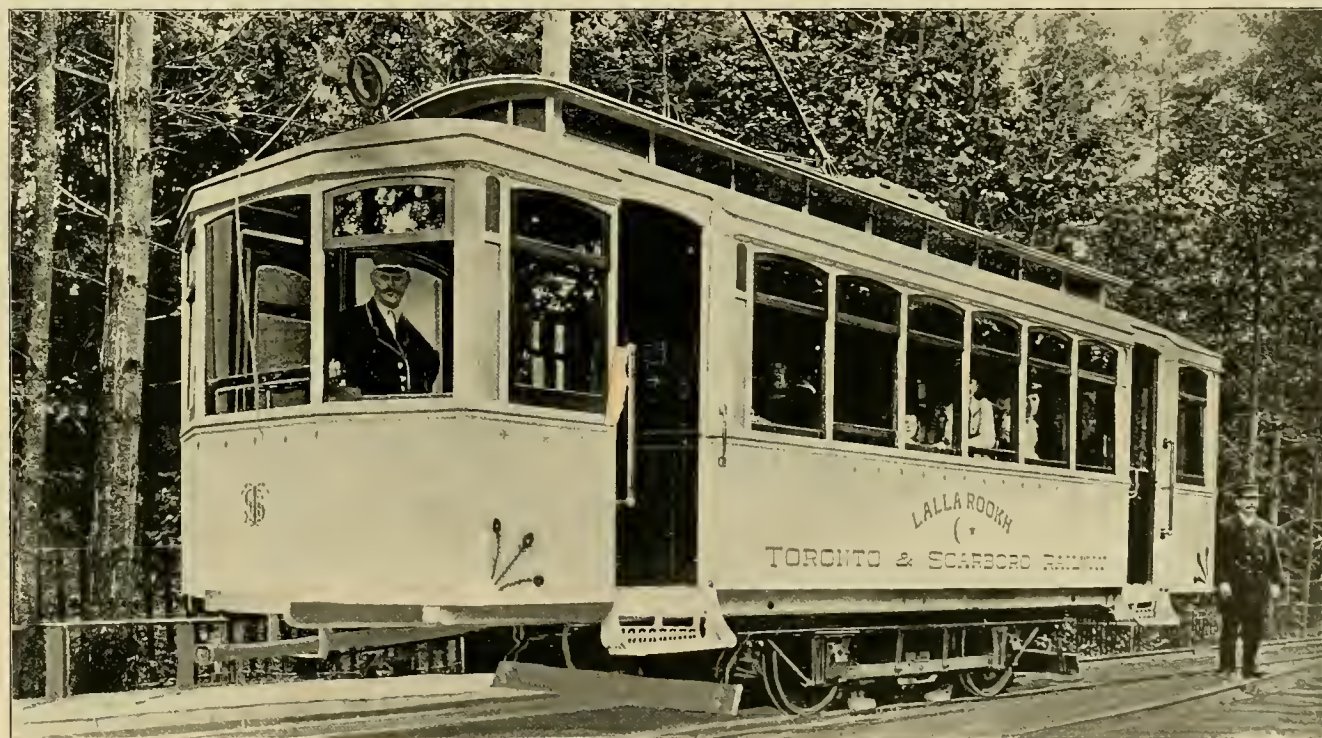

THE LALLA ROOKH OF THE TORONTO & SCARBORO.

tions as to construction and decoration were prepared by General Manager A. W. Dingman, assisted by the company's engineer, John Gault. The car is 29 feet over all and 8 feet wide. It is divided into three compartments, the central one being 15 feet, and the end ones 7

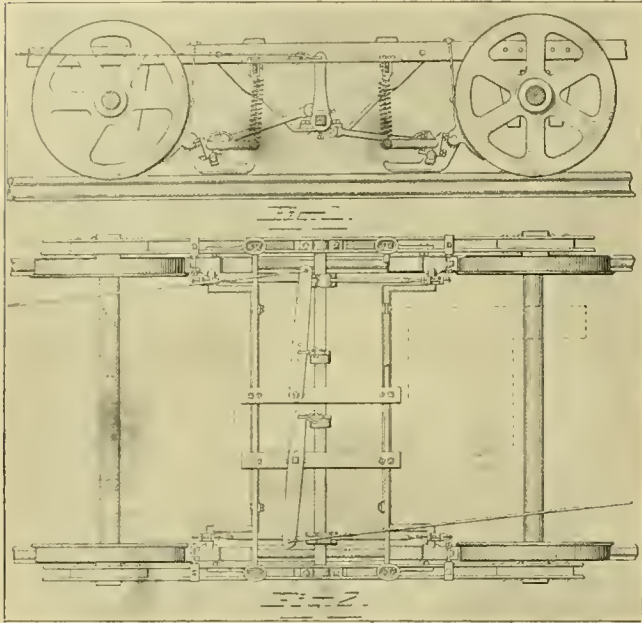

TANDEM BRAKE—LALLA ROOKH.

feet each. In the central compartment the seats are reversible and placed crosswise, the same as in the narrow-gauge railway coach. Double sliding doors separate the central compartment from the other parts. The end compartments, or vestibules, have side seats, and wide sliding doors for the ingress and egress of passengers. The central compartment will seat twenty-four, and each end compartment will seat four, making thirty-two in all, and the door construction makes it impossible for a jam to occur when the car is crowded. The interior finish is mahogany panelled, the ceiling birds-eye maple, the windows are plate glass, and the curtains are oakette. Four double electric chandeliers, two in the central and one in each end compartment, give the illumination, with two outside electric headlights. The outside of the car is painted in two shades of white, the decoration is in gold stars and peacock feathers. The car body was built by the Ottawa Car Company, Ottawa, Ont. The truck is a Taylor, made specially heavy for this car, and the two motors are 30-horsepower Westinghouse No. 12, furnished by Ahearn &

Soper, of Ottawa, who are the Canadian agents for the Westinghouse system.

All will be interested in what General Manager Dingman has to say regarding the peculiar form of brake with which his cars are fitted. He says:

"The brake used on this car, and in fact on all the cars of this line, is the tandem brake, which has proved to be with us what I believe every manager is looking for, namely, a brake that will stop a car at any time, on any grade or at any speed, without skidding the wheel. This brake has two shoes, one on the wheel and the other on the rail, both working simultaneously on one shoulder, and with one application of the brake rod. The application of the brake is made by a 12-inch wheel, the same as is used on the ordinary freight car, with the exception that the wheels are nickel plated and the shafts polished steel. A boy 12 years of age can control this car on any grade more easily than a strong man can control a car with the ordinary brake on the level."

Speaking of the car in general, he says: "The 'Lalla Rookh' is universally admired, and the people wait over from the other cars to ride on it. When the windows are lowered, it has the advantage of an open car, and by the arrangement of the seating capacity is considered the most comfortable and cosy coach on commission. By the utilization of the vestibule spaces we have an elegant smoking compartment, where the conductor stands, and an equally fine lookout compartment for ladies where the motorman is. The car will seat thirty-two people comfortably, and will hold all that can crowd in. I can understand that many car builders and managers will say that it is objectionable to have people in with the motorman, but as it is a fact now on nearly all lines that when the car is crowded the motorman is completely surrounded by people at the time of the most danger, the presence of a few people in the vestibule at the time of ordinary traffic, does not, in my opinion, to any

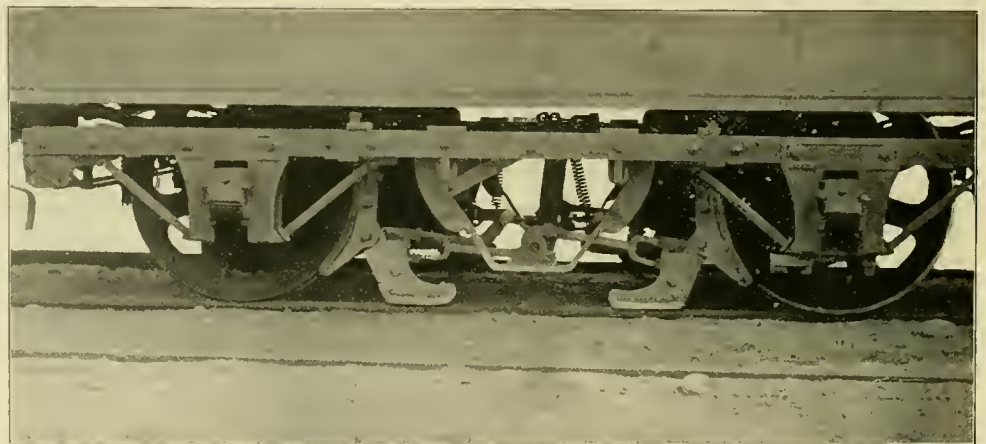

TANDEM BRAKE—LALLA ROOKH.

great extent interfere with the motorman's liberty. On the contrary, the side seats being occupied by passengers, makes it almost impossible for the motorman to be crowded, and it is more comfortable than with the old system of open platform."

## THE OVERHEAD CONSTRUCTION OF THE NEW ORLEANS TRACTION COMPANY.

By B. Willard, Electrical Engineer of the Company.

In the April number of the REVIEW there appeared a description of the electrical construction of the New Orleans Traction Company. This was entirely on paper at that time, but has since developed into a reality, and I take pleasure in placing before REVIEW readers some views taken from various portions of the line, which are the results of plans brought into actual practice. In



FIG. 1.—SECTION SWITCHES.

Figures 4 and 5 of the April issue (reproduced here) was shown a method of making the trolley line sectional and yet maintaining the properties of a continuous wire, by inserting fuses across the section insulators. This has been accomplished somewhat differently than was at first anticipated, by using two switches on one pole, as shown in Figure 1. By following the connections from the feeder wire down to the switch box, it will be seen that the current will be split at a point entering the switch box, part feeding either section on each side of a sectional trolley line insulator which is introduced in the line at that point. Should there be an excess of current required on any one section, every feed wire in the whole system may deliver its share of current to the needed point; thus an even potential is produced at every point on the line, while the greater loss takes place in the feed wires.

Each section box is provided with fuses on either wire leading to its respective sections and a direct short circuit

caused by the breaking of the trolley wire would disconnect only one section. Each section pole carries a lightning arrester so connected as to take care of both the trolley and feed wire. The section boxes and the lower half of the section poles are painted white so that the motorman may distinguish them from other poles and be prepared to shut off the current while passing section insulators in the overhead wires.

For information of the emergency forces each section box contains its respective number and each pole in the section which is controlled by these section boxes is also numbered by what might be called a block system. For example, the poles in the twelfth section would be numbered, 1201, 1202, 1203, 1204, etc. until the next section is reached when the numbers would continue 1301, 1302, 1303, 1304, etc. The emergency forces being acquainted with the various sections throughout the city can respond to the exact spot by simply knowing the number on the nearest pole to where their services may be required.

Figure 2 shows 500,000 circular mil feed line construction leading from the power station. The poles are of special heavy design being sawed out of heart pine lumber; dimensions, 15 inches at the butt and 10 inches at the top set 8 feet in concrete. The cross arms are 3½ inches x 5 inches x 6 feet and contain six pins, all of which are bolted, and support top groove glass insulators for carrying the cables. Figure 3 represents a junction pole showing how feed lines of one road are connected to trunk line feeders. Figure 7 (shown in plan in Figure 6) represents a junction pole showing how the smaller feed wires are connected to 500,000 circular mil cables. It will be seen at this point that there are two large and two small main feed wires ending on one side of the lower frame work (or junction frame). At right angles to these wires are 8 No. 0000 wires leading in another direction which go to their respective "feeding in," sections on the trolley line. All these wires are ended on



B. WILLARD.



FIG. 2.—500,000 CIRCULAR MIL FEED LINE.



FIG. 3.—JUNCTION POLE.



FIG. 9.—NEW ORLEANS CITY & LAKE MOTOR CAR.

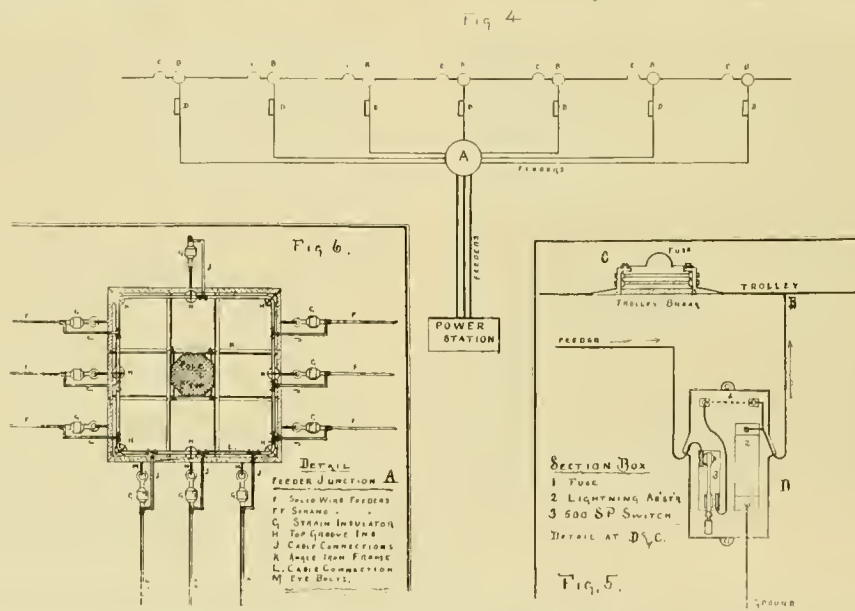

FIG. 4, 5 AND 6.

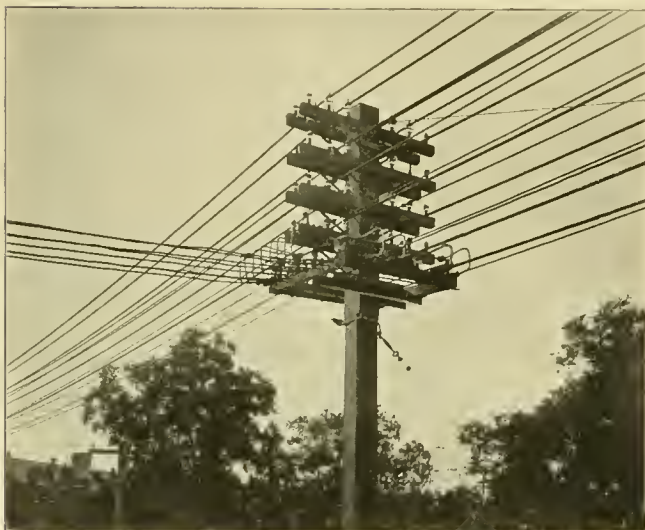

FIG. 7.—JUNCTION POLE



FIG. 8.—STATION TERMINAL.



this junction frame and contains T connections which carry short wires leading to a  $\frac{7}{8}$  inch copper bus rod which encircles the frame; thus making it possible to disconnect any main or branch feeder at a moment's notice, also making a reliable and neat appearing piece of construction. Figure 8 represents a station terminal and anchorage pole. This is very substantially constructed and made to carry a strain of 19,000 pounds with safety. All the wires and cables are dead-ended at this point, in strain insulators capable of sustaining 6,000 pounds each and the whole frame is heavily guyed to two heavy iron anchor stubs, the setting of which required nearly 30 yards of concrete. The main load or strain carried by this frame work is di-

REPORT OF BALTIMORE'S CAR FENDER COMMITTEE.

Some months ago F. C. Latrobe, mayor of Baltimore, John A. Robb, city register, and A. E. Smyrk, city commissioner, were deputed by the city council of Baltimore to make report upon the subject of fenders for street cars, and to select some type or types for the city use. Mendes Cohen, C. E., Baltimore, was made engineer to the commission, and his recently published report is a valuable addition to the literature of street railway devices.

Mr. Cohen says:

"It is somewhat curious that a similar, though by no means identical problem, was pre-



FIGS. 10, 11 AND 12.—TOWER WAGON.

rected to angle iron cross arms "which are not clearly shown in the picture" and each one of these cross arms are so tied together as to bring a general strain on all parts of the structure.

Figures 10, 11 and 12 show the tower wagon in use here for line construction, as well as some of the surroundings through which our cars pass.

Figure 9 shows a motor car on one of the lines constructed by the New Orleans Traction Company, and is a good representation of the general conditions along the several routes now in operation.

PRESIDENT D. F. HENRY, of the Federal Street & Pleasant Valley Railway Company, of Pittsburg, has invented a new non-oscillating truck, of 10-foot wheel base. A trial with a 9-foot base was very successful.

sented for solution some sixty years ago, when the steam railroads of the country, then few in number, found themselves in constant danger, and subjected to much expense from cattle wandering upon the railway tracks, which were then unfenced. The difficulty was first successfully met on the Camden & Amboy Railroad by the construction of a "cow-catcher," as it was called. This consisted of an inclined platform, some five or six feet in length, hinged at the front of the locomotive, at a distance of some fifteen inches above the rails, and extending forward and downward to within a few inches of the rail. Finally, however, cattle owners learned to confine their stock, and the "cow-catcher" developed or rather shrunk into the modern pilot. Now we are met by a very different condition of things. We are called upon to find a car fender

or guard; not to save cattle or dogs, not to brush aside sticks or stones which might throw the car off the rails; not to pick up or throw aside "dummies," but to save, as far as possible, loss of human life, or personal injury to an unfortunate human being, caught in any position, erect or prostrate, upon the tracks of an approaching street railway car. If the car without any protecting device strikes a human figure in erect position the person is certainly knocked down. If the speed be moderate, say not exceeding six miles per hour, the injury sustained by the person in striking the pavement may or may not be serious. The effect of the blow is probably sufficiently stunning to prevent the person recovering himself and getting out of the way of the running gear of the car which follows quickly upon him, and the chances are great that he will be crushed by the wheels. If the speed be high, the force with which the victim strikes the pavement is likely to be sufficient to fracture his skull, and the running gear of the car finishes up the work in a few seconds, unless the victim has fallen clear of the track. It is evident, therefore, that if there is to be an effort made to reduce the amount of injury done in such case, it must tend to save the person from being thrown to the pavement. To effect this, a guard or fender is requisite in front of the car, which shall, if possible, catch and sustain the victim until the car can be stopped. Numerous devices, claiming to effect this result, have been presented, some, of which, likely to prove more efficient than others, will be discussed further on. It is not to be overlooked that the placing of a fender in front of the car may be said to increase the risk of these accidents, which its use is expected at least to mollify. It practically lengthens the car to the extent of its projection, and, therefore, takes up so much more of the public street. It may easily happen that a person imprudently crossing the track in front of an approaching car has miscalculated its speed and distance so narrowly that he is struck by the fender, whereas, if there were no fender, the car would at that instant have been three and a half or four feet distant, far enough, possibly, for him to have cleared it altogether. It may be further said against the use of a front fender that the skeleton frame likely to be used for such purpose in order to save weight will not afford surface enough to be readily and clearly seen, and that its presence will therefore tend to increase the likelihood of accident from miscalculated distance of the approaching car. \* \* \* It is probably requisite that fenders of this class shall be capable of being folded back against the dashboard of the car so as to be out of the way when the car is housed, or its direction reversed. Many of the devices are so arranged as to be readily transferred from one end of the car to the other in the last-named contingency, but the method is undesirable, and to be avoided, if possible."

Mr. Cohen further goes on to express his doubts as to the ability of the projecting fender to pick up people who have fallen on the track, with any degree of certainty. He thinks that there is great danger that such fenders will mount over and crush their victims. Another form

of fender is considered, which is immediately in front of the wheel, and can be adjusted close to the pavement. His opinion is that there should be a combination of the two forms. The wheel guard would, according to his idea, save after the other failed, as it frequently will. Seventy forms of fender had been submitted. He concludes with a classification of the fenders presented and a mention of some particular forms that have elements of success. No particular form is recommended, however, as none of them fill all of his ideas as to requirements. He suggests that there is a tendency to too much complication in present inventions along this line.

#### GENNETT AIR BRAKE COMPANY.

In view of the fact that there are 375,000 Westinghouse air brakes in operation there ought to be no doubt among street railways as to their efficiency. The Gennett Air Brake Company was organized for the exclusive purpose of making street railway air brakes and makes this its business, confining itself to the manufacturing of this one thing. It has a fine plant equipped with machinery built expressly for making air brakes. Following the

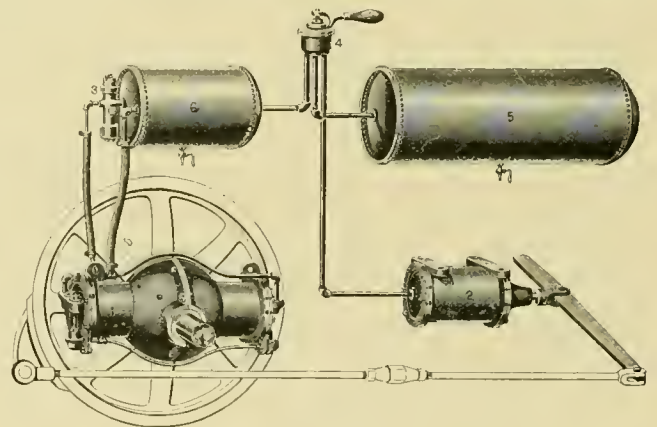

GENNETT AIR BRAKE.

example of motors, the air pump has gone through a process of evolution and it is now in a compact form, entirely enclosed, on the axle, and water and dust tight. It is double acting. There is very little friction to it. During the past three months important contracts have been closed in a number of places in this country. The last one was a repeat order from the Buffalo Railway for 25 brakes. A number of cars are also being equipped for New Orleans and Brooklyn, N. Y. General Manager Wessels who has been sick for some time recently returned with health and strength to take up the affairs of the company after a six month's residence in Bermuda. He is a man of unlimited push and will leave nothing unturned to advance the company's interests.

THE Chicago General Street Railway has let contracts for new machinery to go in its new power plant as follows: One 450-horse-power Corliss engine to the Bates Machine Company, Joliet, Ill.; one 300 kilowatt generator to the General Electric Company, and two 200-horse-power boilers to Abendroth & Root.

## SPERRY ON THE ELECTRIC BRAKE.

Few electricians who have seen the beautifully simple and effective Sperry electric brake in daily service on the several roads on which it has been placed, would have realized the immense amount of research and pioneer work which its perfection involved, were it not for the paper which its inventor read before the American Institute of Electrical Engineers, on September 19. The paper is a valuable contribution to electrical literature, not only on account of its bearing on railway work, but on account of certain theoretical considerations. Mr. Sperry began his work on the electric brake in 1882, at which time he studied its application to continuous railway trains. Since then, the apparatus has been constantly undergoing changes until, within the past 18 months, a constantly increasing number of cars have been equipped. The brake, in its perfected form, was described in the August (1894) REVIEW. It acts on the principle of turning the motor into a generator for supplying current to the brake magnets. The original form

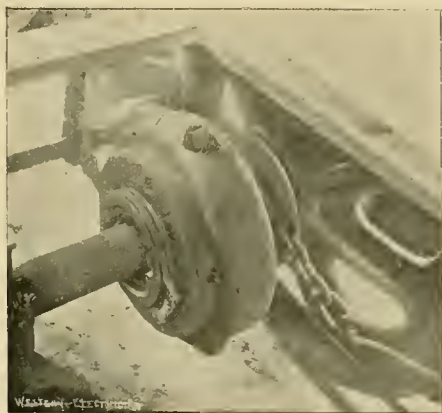

FIG. 1.

of brake magnet is shown in Figure 1, and the present forms in Figures 2 and 3. Mr. Sperry has experimented with a great many forms of magnet for this purpose, and as simple as the present form is, it is the outgrowth of a long study. It was during some preliminary experiments that an unexpected phenomenon was noticed, namely, that the retarding effect when speed is an element, is very much more than would have been expected from the co-efficient of friction due to magnetic attraction or adhesion, this latter being a known and definite quantity. Farther experiment, made to ascertain the cause, showed it to be due to Foucault or eddy currents set up in the masses. The conditions and structure of the brake magnet was therefore varied in a number of particulars, especially such as would be expected to give the greatest result in Foucault currents produced. The result was immediately successful. It was found that the retarding effect of the brake magnet is due very much more to the generation of these currents than to the direct effect of the co-efficient of friction resulting from direct magnetic adhesion, the amount of which can be relied on

accurately when employed by itself. Some of the forms of brake magnets experimented with were provided with numerous poles of opposite polarity, which were worked

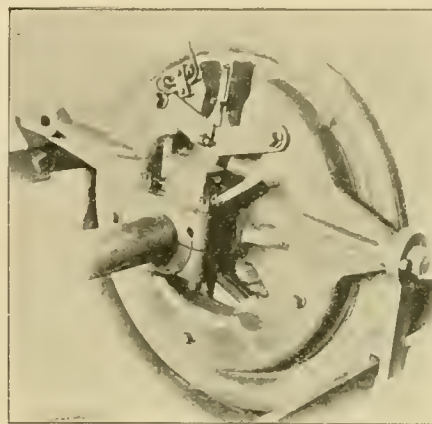

FIG. 2.

upon three different kinds of armature, two of which had radial teeth of different number relative to those in the magnet, and one being a plain disc armature. The toothed armature, while it causes a series of sudden jerks and is also unsatisfactory in the total retardation resulting from a given input is found also upon rupture of the magnetic circuit to impart to the magnet coil certain counter E. M. F.'s which materially cut down the current supply and thus the capacity of the device. A magnet formed of a continuous disk with an annular groove sunk in its face, is found to give satisfactory results, but is much heavier and requires an armature twice as heavy for a given number of lines as the double circuit magnet shown in the figures. Furthermore, the relative rotation between such a magnet and its armature affords no point in the masses where the lines are interrupted or changed, and the Foucault currents, or reactionary effect set up, is very much inferior to that in a magnet where a gap or cessation of magnetic stress is easily produced. As a

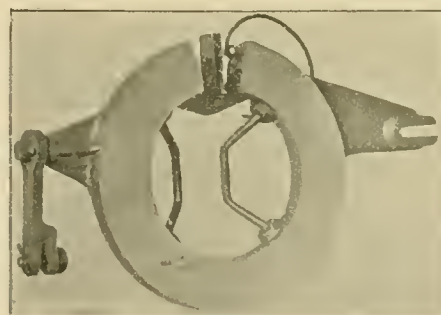

FIG. 3.

result of these investigations the crescent form shown in the figures has been adopted, the opening in the crescent giving the effect referred to, as well as affording an excellent method of attachment and removal of the brake magnet, and at the same time supplying a gap for easily reaching the face for inspection and lubrication.

Thus it is seen that the crescent form is not only about the most convenient one that could be devised from the mechanical standpoint but that there are important electrical reasons for the form adopted.

In developing this system, the point which seemed fraught with the most difficulty, and which has finally received the simplest solution of any in connection with the problem, was that of obtaining always and with absolute certainty, sufficient current at the lowest speeds without the aid of the trolley current. Teaser coils were



FIGS. 4 & 5.

at intervals resorted to, maintaining connection with the trolley circuit. "Artificial teasers" were also used, being a device by means of which the trolley circuit was entirely done away with, and which worked well. Observations made from time to time in connection with these experiments led to an exhaustive investigation of residual magnetism, in consequence of which, structural means were adopted to utilize to the full, the residual magnetism of the motor. This supply is constantly being renewed with every energizing of the car. This method was found to be the simplest as well as the most effective. The connections, and in fact the whole arrangement of the electric brake upon the car, is extremely simple. This is shown by the fact that only one small extra wire needs to be run to the controller in addition to the ordinary wiring of the standard equipment without the electric brake. The certainty of operation is evinced by the fact that 150 of the equipments have been placed, which are making upwards of 10,000 miles daily in regular service. Early in the experimentation a phenomenon was observed in reference to the persistence of the current even after the motor had stopped. This is due to the slow action of the decreasing magnetization, taken together with the reaction or self-induction effect of the fields and any brake coil or coils that may be in the circuit. The movement of the magnetic lines, which persist after, and in fact long after the motion of the motor has ceased, generates potential. In many instances it is possible to draw an arc from the rupture of the brake circuit one second after the motion has ceased, showing the presence of current in the local circuit. Figure 4 has been developed from the average stop to show the curve of current in reference to the motion, the black lines indicating the period of motion during the application of the brake, and the curve indicating the current intensity and its duration. The current flowing after motion ceases, though small, is found exceedingly useful in holding the car from starting itself, even on quite a heavy grade, as only a small quantity of energy added to the already

great friction of quiescence will prevent the car from starting. This persistency of current is also found useful to kill or destroy the magnetism of the brake magnet, in case it is desired to suddenly move the car forward again. The tendency on the part of the windings at the moment of rupture to generate an opposing E. M. F., tends to suddenly free the magnet from its face, a purely accidental feature, which is of great value and utility in this connection. The wonderful energy of the withdrawal of the lines of force, being in its manifestations a phenomenon of magnetic viscosity, is illustrated by the following fact: With a perfectly dry track, a great force is required to shear the adhesion and start the wheels slipping. A car going down a grade under these conditions where no brake magnets are present, will, with a sudden application of the electric brake, generate sufficient current to not only arrest the motion of the wheels, but start them going in the opposite direction, the reverse motion being maintained through an interval truly remarkable, in some instances running as high as one and one-half seconds. It will be borne in mind that all the above phenomena are entirely independent of the central station current, the trolley connection having been severed before the brake is applied.

The current required to be developed to stop a car when no other braking apparatus is used, is found to be only a fraction of that required to accelerate the car in the same interval. This may be easily illustrated by the lines in diagram Figure 5, A being the electrical energy applied in a given acceleration; B the resulting mechanical energy stored in the car after deducting all the wastes in the motor, and between the motor and the momentum; C the average mechanical energy in the car at the time of applying the brake; D being the electrical energy required to be developed for retardation after the efficiency losses have all been provided for out of the quantity C. Thus it will be seen that the so-called efficiency losses act in a two-fold sense, between A and B and between C and D, to reduce the amount of current required to be generated for braking purpose.

As to the effect of the electric brake on the total temperature of the motor the following experiments were made. A car and trailer were operated over the line in regular service 41.1 miles without the brake. The temperature of the atmosphere was noted every half hour during the test, and the temperature carefully taken of all parts of the motor at the end of the run. The succeeding day a similar run was made with the same trailer over the same track and in the same length of time, but with the electric brake in use, braking direct on the simple local circuit without brake magnets. The difference in the average atmospheric temperatures during the two days was six and one half degrees, and the difference in the average temperature of the motor parts was seven degrees, making only a difference of one-half of one degree Centigrade as the total increase of temperature from the use of the brake. Observations in reference to the heat in the rheostat were made, although no temperatures were taken, and no difference could be

observed in reference to the heating of this portion of the equipment. The explanation will be found in the comparatively small amount of current as seen above, and the relative infrequency of its application, and short duration at the time of each application.

This information regarding the heating of the motor and rheostat when the motor alone is used as a brake and no brake magnets are employed is important, as it has been a popular impression that this use of the motors would cause undue heating of motors and rheostats.

It is safe to say that Mr. Sperry's paper marks an era in electric railway engineering, and that the electric brake will see a more rapid development in the future.

### THE TAMA & TOLEDO ELECTRIC RAILWAY.

Two Small Iowa Towns United With a Paying Electric Road.

In view of the present development of the electric railway industry, the little road now running between the towns of Tama and Toledo, Iowa, presents features of great interest. Our readers do not need to be told that the electric railway growth of the future will principally be in the direction of suburban and interurban roads. The railway systems of our large cities are rapidly reaching a point beyond which there can not be much further development unless some use is made of them beyond the carrying of passengers. For the suburban and interurban road, however, there are great possibilities, and in this connection comes the question as to what territories the electric road can run in with profit at present. This is a question of vital and immediate interest to all



POWER HOUSE.

railway builders and promoters, and it is a question upon which every road now operating in a thinly settled territory throws some light. The Tama and Toledo road is of special interest in this regard because it was built in

a place which to an outsider would seem to be very likely to prove unprofitable.

#### LOCATION.

The road is two and a half miles long and runs from the center of one town to the center of the other. Each



TOLEDO TERMINUS.

town has about 2,000 inhabitants. The main lines of the Chicago & Northwestern and the Chicago, Milwaukee & St. Paul Railways, from Chicago to Omaha, cross at Tama. A branch of the Northwestern running to northwestern Iowa leaves it at this point and passes through the edge of Toledo. Tama, as will be seen from this, is somewhat of a railroad center. Toledo is the county seat of Tama county, and is more of a residence place than Tama. A college is also located at Toledo, which of course helps swell the traffic between the two places. Practically all of the railroad travel that comes to Toledo comes through Tama. Previous to the starting of the electric road a stage line ran between the two places, and the Northwestern Railway ran a special train morning and evening in addition to the through trains.

#### TRAFFIC.

July 4, 1894, was the opening day. While it might naturally be supposed that a project of this kind would have to be in operation several years before it would work up traffic enough to pay, such was not the case in this instance, as the road has been a paying investment from the start. The average traffic since the opening has been 300 passengers per day. As a ten-cent fare is charged between the towns this represents about \$30 per day. There are a few five-cent fares collected from those who ride less than half way. This taken, together with the statements made later regarding construction and operation, will show that the investment is an excellent one. Besides the passenger revenue there is an income of about \$3 per day from mail, express and freight. Ten per cent of the entire express charge is received on each express package. Over 4,000 people were carried with two motor cars one Sunday.

## CONSTRUCTION AND OPERATION.

The company is incorporated as the Tama & Toledo Electric Railway & Light Company, and it supplies light to the two towns in addition to running the railway, although it is safe to say that the road could be made to pay were the electric light plant not included. The road is almost straight, with the exception of three curves in Tama. The power house is located in the middle,  $1\frac{1}{2}$  miles from each end. Coal is unloaded into the coal cars of the electric railway at Tama. A profile of the road shows that the general slope from both Tama and Toledo is toward the power house, so that it takes almost no power to haul the coal from Tama, while there is a great

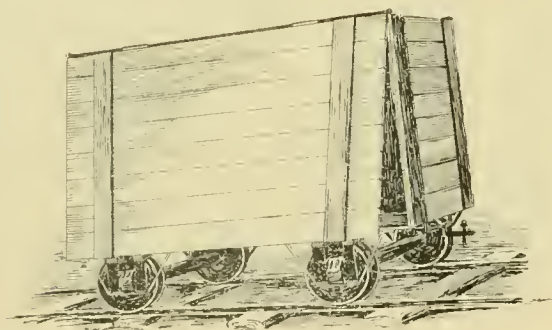

COAL CAR—TAMA &amp; TOLEDO ROAD.

saving in the copper necessary to transmit the current by having the power house at the center of the light and railway systems. In running loaded coal cars from Tama to the power house it is only necessary to start them down the first grade and let them run until it is time to put on brakes at the power house. Except in the town of Tama there is hardly a level place on the route. The heaviest grade is 6 per cent. Twenty-five and thirty miles an hour is sometimes made on the down grades, and as much use as possible is made of momentum for ascending grades. Forty-pound T rail is used with ties three feet apart. A good portion of the right of way had to be bought by the company, but a public highway has now been opened up alongside the tracks, and no doubt within a few years numerous residences will be built along the way. Two or three small cuts and fills had to be made in building the road. Exclusive of the right of way, the construction of the road, including track, track grading and overhead work, cost about \$5,000 per mile. It was built at a time when construction material was very cheap—T rail being at the time \$20 per ton. The overhead construction is all side pole span wire. The entire investment, including the lighting plant for both towns, is said to be about \$56,000. It is of course impossible to separate the light and railway plants so as to find the cost of each. If the railway power plant was constructed by itself and \$150 per horse-power allowed for its cost (which is probably not too low a figure), it would require \$22,500 to build a station having two 75-horse-power engine and dynamo units. Such a station would be sufficient to operate the road under any load that can at present be put upon it,

and would have a reserve sufficient to prevent shutting down the road for any ordinary breakdown. The entire cost of the road and station, according to such a calculation, would be \$35,000, not including rolling stock and right of way expenses. This figure is of course hypothetical, and is nothing more than a guess as to the possible cost of a similar road with a station built entirely for railway work. The station, as it is actually, has of course a financial advantage over one constructed for railway or lighting purposes alone, but there is not much doubt but that the road would pay dividends were there no lighting plant in connection with it.

The ordinary business is handled with one motor car which makes a round trip every forty minutes. As it is possible to make a round trip in twenty minutes, it is evident that it would be easy to give a thirty minute service at a very little extra expenditure for coal and repairs, while the quicker headway would tend to induce more traffic. On special occasions two motor cars are run and a trailer is sometimes improvised by putting seats and a railing on a flat car kept for hauling freight. The rolling stock consists of two box motor cars, equipped with Walker motors, which are giving excellent service, four coal cars, one flat car and one motor baggage car, which has not as yet been used. The coal cars are built with the sides hinged at the top and are run directly in front of the boilers. On being unfastened at the bottom, the greater part of the coal will run out within the fireman's reach without any rehandling.

The entire railway and light plant was constructed under contract by E. B. Hillman & Co., electrical engineers, of Peoria, Ill. The power plant is a neat piece of work, having brick and concrete floors, and employing Ideal engines with the Ideal method of belt transmission. The railway work is done by a 75-horse-power engine and a 50-kilowatt Royal Electric Company generator. The road is under the general management of L. H. Ong.



Johnson—"Say Bill, I didn' see yo' takin' up de collection las' night as usual."

Bill—"No! dey dun insult me by wantin' me to wear one o' dem cash registers."

## SPECIAL PAPER ON "TAXATION."

(Continued from page 610.)

HARRISBURG, PA., Sept. 10, 1894.—Grand Master Sargent, Brotherhood of Locomotive Firemen, said: "I contend that in times like the present, wage workers want the wisest counsellors—men who desire to keep workingmen who can earn their living employed, so that they may contribute a mite to help him who has nothing. They should lend their energies and talents in convincing the hungry toilers of the causes of the great depression and point out a remedy, which certainly is not found by further plunging the avenues of trade into chaos by strikes, applying the blazing torch or in defiance of the laws."—*New York Herald*, Sept. 11, 1894.

### TAXES—WHY AND HOW IS PAYMENT EVADED?

1. Legal honesty is the true standard by which to test the practical moral condition of any people. That this standard is far below the requirements of natural economic law is self-evident. So long as possession of property is considered by practical men to be more desired than good character, the standard of legal honesty will be exceedingly low. While I have an abiding faith in the honesty of purpose, the desire for fair dealing, the sense of justice and the regard for honor that I believe exists in the minds and hearts of a vast majority of men, I do know that the practical effect of contending for gain, in an unceasing war of competition, teaches and compels them to be wise as serpents in seeking and utilizing every advantage that will bring profit to their credit. Present gain is the good practical men seek to win, and in trying to win it, it is not considered to be practicable to inquire what effect the methods used will have on the common welfare, whether or not they are in accord with correct economic principles, or if the profit of one involves a loss for others. The man is prosperous who with clearest judgment utilizes every opportunity to make a gain that he can find, permitting no restraint upon what he does or how it is done, except that he keeps within the law. Such a man cares nothing for economic principles. His mind is never troubled with a desire to see that practical justice is secured for the weakest members of society. His conduct is a product of legal honesty and he helps to fix the standard of legal honesty. Such men never consider whether or not a proposed measure is just; to do that would not be practical business or practical politics. The determining factor is, not the justice of the measure but its promise of profit, advantage, power. By such men, trained by such a business system the enacted laws are written which determine the standard of legal honesty.

2. The practical effect of standardizing conduct by legal honesty; instead of the requirements of natural justice, causes men to place higher value on a present gain in property, than upon good character, causes them to be more intent upon getting that which they think good for themselves than in doing good for others. It blunts their perception of justice and destroys their ability to judge of an action by the principle involved, by which alone its true character can be determined. The standardizing of conduct by a false standard makes it difficult for men to realize that the taking of a dollar from another by unjust indirect methods is in fact and in actual effect a transaction of the same character as the taking of a dollar directly from the victim by brute force. They do not realize that personal rights are invaded as effectually by fraud as by force. For this reason many persons are guilty of acts of injustice by indirection who would be the first to hotly defend their victim from an attack by force.

3. After ages of experience, when practical men learned that greater profits are realized in a society where life and property are safely guarded from plunder by force than where they were not so protected, such plunder was stopped, but the disposition to plunder was not thereby eliminated from human nature. It at once reasserted itself in more subtle and refined methods of plundering by fraud. The time will come when practical men will learn that profits will be far greater when all plundering by fraud is stopped and then it will be stopped. The weakest member of society will then have as perfect protection in the ownership and enjoyment of his just share of the values produced by the joint use of labor and capital, as he now has for his life, and the pursuit of happiness will be less difficult for the masses who toil and are poor.

4. Payments of taxes are evaded because a blunted perception of justice prevents men from seeing that a failure or refusal on their part to pay their just proportionate share for the support of the government, necessarily compels others to pay more than their just

share and that the evasion is fraud on them instead of on the government. Many people think or care so little about the ultimate effect of their conduct upon others, they never know that an evasion of the payment of taxes is a robbery of individuals. They regard the government as an impersonal entity to defraud which has no moral significance. To such an extent is this true, that it is almost impossible to control many persons in their dealings with the government by the same rules of conduct they unhesitatingly obey in their dealings with individuals. In defrauding their friends and neighbors by indirection, through defrauding the government, they feel no restraint from the powerful influences exerted by a clearly expressed public opinion and a discriminating sense of high personal honor. Because of the indirection of the robbery and because of the inability of many to guide themselves by a principle when they cannot directly see the ultimate effect of their actions, an evasion of tax payments is not only considered "good business" by the one who is a gainer by the practice, but is so considered by many persons to whom it may become known, who for the same reasons are unable to see that they have been robbed by the one whose shrewdness they admire.

4. To the class of legally honest tax-dodgers must be added the class of the inherently dishonest, whose greed for gain suffers no restraint from natural or enacted law. They may not know that their act is robbery. They would not care if they did.

5. It is a natural sequence to find tax laws enacted by defective human nature extremely unjust. There is a class of legally honest tax-dodgers who would willingly take their oath that they never dodged the payment of a tax bill. That statement may be exactly true, and yet of all tax-dodgers they are the worst and most dangerous class. It is in response to their demands that unjust tax laws are enacted for the direct purpose of placing a portion of the tax they should pay upon others. They are tax-dodgers in the first place because they evade paying their fair share of taxes, through the operation of legal enactments, and in the second place because the unjust laws enacted for their benefit cause an enormous amount of tax-dodging on the part of those who resort to such action in resentment of the injustice of the law. This class of legal tax-dodgers must be very large, or unjust tax laws could not remain on the statute books a single year. They must be rich, because an attempted change in tax legislation to make it more just is stoutly resisted by them. The poor give no heed to such action only as their prejudices are played upon to incite them to strike at organized capital. These legal tax-dodgers are all very respectable and honest, legally honest people. Some of them may not believe the tax laws to be entirely just, but the law is in their favor. No one expects them to force the tax collector to take more than he asks. They pay what is demanded of them. If the demand on them is less than it should be, and for that reason must be greater on another than it should be, that is not their affair, it is the law, and that is sufficient answer for them. They are the ones who insist that all securities should be taxed as personal property; why? Because their property is in real estate, and if to the total valuation of real estate the total valuation of some securities is added, the rate per cent on the combined total will be less and their tax bills will be smaller. This is all there is of the demand to have securities taxed. It is an effort to make tax-dodging legal, and whenever such a law is enacted this is its effect.

6. The honesty of those who demand the taxation of securities can be easily tested. Stop contending with them and take them at their word. Say to them all right, tax securities, if you wish, but there must be no discrimination. If you tax one, you must tax all, equally. What would be the result of this? The Comptroller's report, State of New York, 1894, gives items for 1893 as follows:

Real estate .....	\$3,626,645,093 00
Personal property.....	411,413,856 00
Total property valuation.....	4,038,058,949 00
State tax, levied for all purposes	10,418,192 08
Rate of tax in mills on each dollar in valuation	

2.581  
100

The fact is indisputable that all of this real estate is covered by a security representing its ownership and called a deed. There is no difference in character between a deed and a certificate of stock. They are both securities representing ownership. Neither of them has any value apart from the value of the property the ownership of which they represent. Therefore, it is simple justice, if the property represented by a certificate of stock is taxed, and then the certificate of stock itself is taxed as personal property, or in any other way, to require that deeds representing the ownership of real estate should also be taxed after the real estate had been taxed. Under this ruling

the item of personal property in the above statement would be increased by the entire amount of real estate valuation, and the tax levy on the new total of valuation would be  $1\frac{8}{10}\%$  mills on each dollar of valuation. The real estate owner, however, would pay this rate once on the value of the property and once on its representative, or what would be the equivalent, he could pay  $2\frac{7}{10}\%$  mills on each dollar of valuation on his real estate instead of  $2\frac{1}{10}\%$  as he is now doing. The increased tax on all of the real estate would amount to \$507,630.30. This amount would, of course, be taken from the present tax on personal property, and the tax on the valuation of personal property as it stands in the table would be reduced to  $1\frac{8}{10}\%$  mills on the dollar. This shows a legal evasion of the payment of \$507,630.30 of taxes by real estate owners and the assessment of that amount on that portion of the people who, through honesty or inability to hide their securities, suffer them to be taxed on personal property under the law. It must not be assumed that this illustration is technically correct because there are many things mingled with securities in the general classification of "personal property" that are property, not securities, and would be assessed for taxes under a law providing that all property shall be taxed and that securities shall not be taxed. The illustration is simply intended to show the injustice of the law in classing securities as property for the purpose of taxation, because they are representatives of the ownership of the value of property, and then failing to so class and tax all representatives of the ownership or of the value of property. Such laws produce all of the effects of tax-dodging, and should be known by their true name as tax-dodging measures.

7. When tax-dodging laws are in force their necessary effect must be to tax the man unjustly who standardizes his conduct by the natural law and does not evade taxation. He cannot sign a tax return nor permit one to be made for him purporting to list all the securities he owns which is not a true return. Having all his securities listed there is no relief under the law but to submit and pay the tax assessed upon them. The legal tax-dodger knows the law is not just. He sees that the law itself is dishonest, and therefore esteems himself as legally honest if he can find a way in which to evade the law without subjecting himself to a penalty. I believe that the legal fallacy that the evasion of tax payments is not theft is responsible for nearly all tax-dodging, because it protects tax-dodgers from punishment by imprisonment. To dodge an unjust tax is remarkably easy, when there is no restraint from moral principles upon the many methods that may be employed. To illustrate: "A" being in New York city may have a friend, Mr. "B," in Jersey City, whom he can trust. "A" can give his securities to "B," and then he will not own them on the date of his tax return, nor will they be within the jurisdiction of the state. When it is "B's" turn to get relief, "B" can use "A" in the same way and for the same purpose. This act is as honest as the law, therefore the law cannot punish it. No one should be deluded with the idea that this method of tax-dodging is confined to the very wicked men, as some think them to be, who have been successful enough to own securities. By accident it could not have been by the design of honest men—that laws of adjoining states are so arranged that the returns of farm property are made for a certain month in one state and for a different month in the other state. The returns call for an enumeration of live stock. Result: The legally honest farmers, who it is supposed are to be depended upon to vote for the taxation of securities because they have been permitted to think that they do not own any, drive all their live stock into the adjoining state, for pasturage, of course, and keep it there during the month in which it would have to be listed for taxation if it were on their own farms. Not being on the farms or in the state, the legally honest man can sign a return showing that he has no live stock in the state except that which is exempted by law. The season moves on, and by the processes of nature and the imagination of man, the pasturage has become so much better in the first state to pass through the taxation period, all the live stock that has been driven out of the state to be pastured and evade taxation, is brought back, and with it comes as much more which is the property of the other state that is about to pass through a season of short grass and tax returns.

8. Deep as the economic injustice of dishonest tax laws is, the deeper injury is in the lowering of the standard of honesty by which very many men, it may be a clear majority of men, standardize their conduct. The property gain secured as a result of tax-dodging, whether it is done by direct legal enactment, or by evasion of the law, invariably enriches the dishonest man and robs the honest. All unjust tax laws place a premium upon fraud and place honest deal-

ing at a discount. Is this "good business" for the community? Is it "good business" for those who grow rich on such ill-gotten gain? Make a plain statement of these questions to the people, so there can be no evasion of a correct understanding of their meaning, and ask them to answer whether or not the time to stop plundering by unjust taxation has arrived. Their answer, if secured void of the prejudices and subtle misleadings of political influences, will ring true to the principles of natural justice and will demand the enactment of tax measures that will acknowledge and enforce the equality of all property before the law—dollar with dollar.

#### TAXES—BY WHOM SHOULD THEY BE PAID?

1. During the discussion of the income tax in Congress the argument was advanced that the measure was vicious because it sought to relieve persons having small incomes from the payment of their share of the expenses of government, and that in so doing a foundation would be laid for relieving them of their share of political power. It was claimed that those who pay the expenses of government would govern. This view does not take account of the fact that the government requires two classes of services, both of which are essential to its existence: one is personal and the other financial.

2. After ages of effort to acquire freedom of thought, freedom of speech and freedom of person, the principle that all men are endowed with "equal natural rights, to life, liberty and the pursuit of happiness," has been affirmed and irrevocably fixed in the foundations of the government. Equality of personal rights carries with it, as a necessary resultant, equality of personal duties; therefore for the personal service required by the government all men stand pledged equally, man with man. In its true meaning this pledge does not require each man to render an equal personal service, incapable with the capable. It does require that each man shall render the best service of which he is capable. While capabilities are widely different, the obligation that each shall do his best is laid equally upon every person. The capability of each is the standard by which the personal service he may be required to render is measured.

3. In the process of constructing or reconstructing a government that derives all authority from the consent of the governed, it has been and still is necessary to settle political questions before economic questions can be properly dealt with. Every great movement is based upon an economic principle. While this is true, in the past contention has centered upon political questions having to do with the powers and mechanism of government, and with personal rights. It was necessary that men should acquire their freedom and get the powers and mechanism of government thoroughly under their control before they could institute economic policies designed to establish justice in the control of the great forces by which wealth is produced and distributed. For these reasons economic questions are only now beginning to present themselves for settlement as independent measures. First of its class and generic in its relations is the question of taxation.

4. The principle of the natural right to personal freedom being established, the next step of progress is to establish the principle that all men are endowed with equal natural rights to the ownership and unmolested enjoyment of the full value of their labor. Labor to have value must be expended in the production of something that is valued by others. Equality of property rights carries with it as a necessary resultant, equality of property duties, therefore for the financial service required by the government all property stands pledged equally—dollar with dollar. This pledge does not require each person to render an equal financial service, those owning little with those owning much property. It does require that each shall render the service in proportion to his ability. While the property owned by each is widely different in value, the obligation that each shall contribute according to his ability is laid equally upon every person. The ability of each is the standard by which the financial service he may be required to render is measured. This affirms the principle of equal property rights and equal duties of property for all men. This is the next principle to be irrevocably fixed in the foundation of government. The payment of taxes is a financial service that can be rendered by property only. A recognition of the principle of the equal property rights and duties of property for all men requires that taxation shall be levied upon all property equally. Any departure from this standard must result in taking more than their equitable share from some and less from others; a condition that cannot be permitted to exist if justice is to be established.



5. The necessity for organizing a government to enforce obedience to law in order that men may be protected in the enjoyment of their natural rights, is clear proof that society contains many members whose diseased brains and hearts permit and impel them to take from others by force or fraud that to which they have no right. The ingenuity of man has exhausted itself more completely in efforts to find ways of obtaining property without working for it than in the pursuit of any other object. The effort to obtain value without giving value in return has its counterpart in the effort to retain value while enjoying the benefits for which value must be paid by some one. In one case the fraud is direct, in the other indirect, but the economic result to the victim is the same. In no way can direct fraud be practiced so safely and effectively as by the enactment of unjust tax laws and the evasion of the payment of taxes. Unjust taxation uses the organized power of the government to wrongfully take for its support a greater proportionate share of the property of one than of another. This is an invasion of the personal rights which all honest men are equally interested in resisting and stopping. Unjust tax laws make a government organized to establish justice through the protection of life and property untrue to its purpose, and causes it to become an oppressor at the very point where it was designed to be a protector. The unequal burdens of taxation placed upon the honest to satisfy the demands of, or by reason of the cupidity of, the dishonest, is a tax which may be greatly reduced if not wholly obliterated by means of a wide dissemination of correct economic education.

#### TAXES—HOW CAN A JUST SYSTEM BE ESTABLISHED?

1. Government has no virtue not possessed by the people. It has no sense of justice, no power to discriminate between right and wrong, no standard of honesty other than that contained in the enacted law. A government that derives its powers to govern from the consent of the governed must reflect the vices as well as the virtues of the people. The people are not close students of economic questions and are therefore easily led by dishonest men to do many unjust things simply because they are ignorant of the ultimate effect of such actions. They do not trace the operations and effects of unjust tax legislation, until the fact is as clear to them as the sun at noonday, that all such legislation must give undue advantages to some through placing others at a corresponding disadvantage. When this is made clear to them their sense of honor and fair play can be relied upon to remedy the evil. The desire to escape taxation is born of selfishness and is kept alive by the intuitive disposition fixed in human nature by the tyrannies of the past, to resent or evade every demand made on them by the government. As governments become more just and people become more honest the affirmation will become more universally accepted and voluntarily acted upon, that all men should pay taxes in proportion to the property they own.

2. It is an often repeated remark, heard in every city and state in this country, that it is useless to attempt to secure the enactment of a measure solely on presentation of arguments showing conclusively that it is just and right. I am told everywhere that when legislation is wanted the only way to get it is to buy it. I am sometimes inclined to think that some of the measures persons making such statements have been interested in getting enacted, were not just or right, and that they preferred to buy the legislation they wanted rather than take the risk of defeat through too great publicity. The virus of corruption works rapidly through the body politic. The corrupt do not all hold seats in the State legislature or municipal councils. When all men will refuse to enjoy an advantage, gained by legislative enactment, that they cannot obtain with honor, but little of the legislation that cannot be had without buying it will be asked for. There is a limit to the demands of justice; there is no limit to the demands of corruption.

3. It is not good business to buy corruption. The market can never be cornered. The supply will always be equal to the demand, but no greater. When there is no demand, no reward for corruption, it will not exist. It should also be considered that that which is gained by corruption has no security. It may be taken away by corruption, while that which is gained justly has a sure defence. It can never be taken away by justice. By the establishment of justice the rights of all men are protected. Those who traffic in corruption cannot appeal for protection to just laws. The corrupt do not enact just laws.

4. Buy legislation if you will, but do not delude yourselves with the idea that you have thereby effected a saving or made a permanent gain. The cost of legislation by bargain and sale is many times

greater than that secured through the correct economic education of the people, and does not give a fraction of the satisfaction or security. Here again is a tax unaccounted for and unacknowledged, paid by those who seek unfair advantages through using unfair means. The tax they pay is direct, but the indirect burdens laid on honorable men through the losses and disadvantages they sustain by reason of measures carried by unfair means is incomparably greater. Who can tell where the indirect burdens laid by corrupt legislation begin or end? Who can tell its total cost and why it is paid if there is not a subtle partnership in crime between those who seek and those who grant unfair advantages through legislative enactments?

5. The majority of men are honest in head and heart. Demand only such measures as you can show to them to be just and they will stand with you for the cause of right. Pay you must, but you will find it better business to pay for the correct economic education of the masses and the preservation of your own honor than to buy legislation. The demands of honest and capable men are only those that can be publicly shown and accounted for, and for that reason are much less than the demands of corrupt men. If you do not educate and elect honest men to office you will have to deal with dishonest men in office. You pay taxes not only to support, but to create a government that will establish justice. Without such a government there is no security for life or property, no certainty that correct economic policies can be inaugurated and uninterruptedly carried out. There can be no dependence upon correct economic conditions being established and maintained to induce the highest possible degree of prosperity for individual and public welfare.

6. There are well meaning persons who contend that it is useless to undertake a reform that can be thorough and permanent only through the reformation of human nature. Those who argue thus do not reflect upon what would transpire if their suggestions should be universally acted upon. The tablets upon which the ten commandments are written would again be broken. All effort to establish justice would be abandoned, and civilization would quickly relapse into the barbarism from which it has been evolved by the patient ceaseless work of those who have done, each in his own sphere of action and influence, what he could to reform his own human nature and to assist others in doing the same. Those who refuse to aid a reform because the evils to be contended with are rooted in human nature, must do so because they do not want to reform themselves. A reform to establish justice in taxation must be founded upon the demand that each shall do his fair share and no more. The fair share of each is to so reform his own views that his words, his actions, his influence, his vote, and his just proportion of the expense of educating the masses can always be depended upon for the support of just measures. Those who observe closely will see that the more active they are with words, actions and influence, the less will be the sum required for expenses. A refusal to comply with such a demand can be construed in only one way. It means that the person wishes to dedicate his energies, time and money to money making; to the satisfaction of his desire for power, or to indulgence in his pleasures, while knowing that all success gained by those who carry forward the reform work must operate to his benefit as well as theirs. He is one of the type who are willing to reap where others have sown. This is legal honesty.

7. In undertaking to establish a just system of taxation, the fact must be kept steadily in mind that the forces of evil are entrenched in the existing laws, are cohesive, and have an enormous interest at stake in maintaining and extending the evils upon which they thrive. When those who contend for justice cease to be as vigilant in the discharge of their public duties as they are in looking after their private affairs, the forces of evil make stealthy invasions on personal rights. Corruption grows arrogant on success until its unjust demands strike honest but indolent citizens to the quick. Then these honest citizens suddenly awaken to their duties to find themselves enmeshed in a web of corruption and unjust laws, from which they can escape only by heroic effort and appalling sacrifice. If all honest and intelligent men will always stand banded together, doing active and aggressive work for the cause of just laws and their enforcement, not as a matter of sentiment, but purely as a matter of good business management, they will find that the cost of well directed, continuously sustained effort is not greater than the cost of spasmodic effort, and that the gains from systematic work will be infinitely greater and more satisfactory. As a matter of practical business the effort to establish a just system of taxation should enlist every honest minded man "for the war." No one should think of asking for a

muster out until the victory is completely won. Under such conditions victory is certain. The most difficult obstacle to be overcome is not the evil entrenched in unjust legislation, powerful as that may be, but the paralyzing effect of the apathy of those who will secure the largest proportionate benefit from a just system of taxation, the many who labor and are poor and who, by reason of their ignorance of economic questions, know nothing about the taxes they pay.

8. Every gain made in establishing and protecting the personal rights of the weakest member of society to his life, his liberty and his pursuit of happiness, has been a gain for all who are his superiors in social conditions. So will it be in establishing and protecting his personal right to the ownership and unmolested enjoyment of his just share of all value created by the joint use of labor and capital. Upon such foundation the economic welfare of each individual, of the state of the nation, can be successfully developed. That each shall do his just proportionate share is the foundation principle of just taxation. That each shall do his just proportionate share in spreading and sustaining correct economic education, is the foundation requirement for success in establishing a just system of taxation.

Mr. Foote proposes to provide a just system of taxation thus:

1. All charges for the support of the government and for all other, public purposes are taxes.

2. All property shall be assessed for taxation at its full value in current funds. All exchangeable products upon which labor has been expended, the ownership of which is protected by law, are property. Securities representing the ownership and the value of property are not property and shall not be taxed.

3. The tax levy shall be laid at a uniform rate per cent on the assessed value of all property for the same tax levied within the jurisdiction of the state and of each division thereof.

4. All property assessed for taxation shall be entered in the books of the tax assessor for the tax district in which it is located, in the name of the owner, user, or person having the property in charge.

5. Bills for taxes shall be made in the name of the owner, user, or person having the property in charge, as entered in the assessors' books, and the payment of the same shall be a legal payment for the full amount of the tax bill of any debt or obligation of any kind due from such person to the true owner of the property upon which the levy was made.

6. Tax bills shall be a lien upon the property upon which the levy was made and may be sold for non-payment, as provided by law.

7. Property shall not be taxed in any way except as herein provided. Tax assessments shall be made but once in each year, and the levy for all state, county and municipal taxes shall be entered in the same bill. Charges shall not be made by state, county, municipal or other public authorities, for the support of the government or any other public purpose; except a property tax, for the right or privilege of engaging in any industry, business or vocation.

8. The legislature may exempt the whole of any class of property from taxation, but it shall not make any partial exemption by authorizing a decrease in valuation, or of the rate per cent of a tax levy for one or more classes of property less than the unexempted whole of a class, nor shall it exempt a part of the property of any class.

9. Special assessments and tax levies may be made, in consideration for special benefits accruing from public improvements, upon all property securing an increment of value by reason of such improvements.

10. Fines may be assessed and collected for violations of law; charges may be assessed and collected for costs of courts in all legal procedures; for costs of records on all recorded instruments or documents; for all public inspection, supervision and audits; and license fees may be assessed and collected for the control of all places of public amusement; the regulation or suppression of all immoral practices; the protection of health; and the supervision of public nuisances.

11. The legislature shall not delegate the right to exercise the power of taxation for any purpose, to any public division of the state or other public authority without providing by law that the books of accounts of such division shall be kept as directed by the state comptroller, who shall audit all such accounts annually.

THE Toronto Railway Company paid into the city treasury \$8,332.17 on the September earning of \$104,152.21. Last year the company earned \$92,745.67 and the city's share was \$7,419.67.

## A STANDARD FORM FOR ACCOUNTS FOR STREET RAILWAYS.

A Report to the American Street Railway Association, by H. I. Bettis

MR. PRESIDENT AND GENTLEMEN OF THE AMERICAN STREET RAILWAY ASSOCIATION:—

Your committee on standard forms for street railway accounts begs to submit to you the following as its report:

On September 7 the committee sent to all the members of the association a classification of expenditures, which could be readily adopted for use upon any road, and so arranged that any or all of these accounts can be subdivided to any degree desired by the road adopting them, without impairing its value as a basis for comparative statements. Accompanying this was a circular letter, requesting the accounting officer of the several roads to carefully examine this classification, noting such items as in their opinion are erroneously classified, and also requesting that sample report blanks and special rulings for account books be sent the committee for inspection.

The replies received were in the main very full and complete, and showed an interest in the subject, but the number, compared with the number of members with the association, was very small, and in consequence there was a postal sent out about two weeks later, but with little effect upon the delinquents. The results obtained from the replies received will be taken up later.

Special ruled account books and ruled forms of reports of various kinds are a means to accomplish results. To standardize the means, we must first of all seek the same, or similar results.

If we are seeking uniform results, uniform methods may be employed, and will naturally be employed. Those which are the simplest in form and manner of filling out being preferable.

For this reason the committee urges you to take some steps toward adopting a standard classification, that the end to be accomplished by all will be uniform, and this done, the standardizing of forms and methods of street railway accounting will follow.

At the time the subject was assigned, and until the returns came in from the circular letters, the committee was not aware that a class of accounts had been presented to the association at one of its earlier meetings, in 1884, and long before this committee had even a speaking acquaintance with the street railway business. Had the committee been aware of the fact, it might have understood that its particular function was to prepare a set of blanks, to conform with the classification presented in 1884.

It is perhaps just as well, for with the progress in street railway affairs in the past ten years, the classification presented then, for a road operated entirely by animal power, is nearly out of date, and it would be better to frame one which can be adapted to all classes and kinds of roads, with any or all kinds of motive power, which we believe you will find to be the case of that presented with this report.

In adopting a standard classification as a basis for reports from all roads, we must decide upon the minimum number of accounts into which it can be divided, and yet give all the information that the majority would desire. Each of these accounts must be carefully analyzed, and so closely defined that each particular account shall have at all times the same constituent elements on every road. This much decided, any company wishing any more detail may divide and sub-divide, until there are twice or thrice the number of accounts; but still retaining the distinctive features of each particular group.

With companies formed under the laws of Great Britain, this is provided for by the "Companies Act," by which all railroad corporations are obliged to keep their accounts according to the forms and methods prescribed by the government, and the books are regularly passed upon by a board of examiners, besides annual or semi-annual audits of the assets, liabilities, accounts and vouchers by independent auditors, or chartered accountants. By this system of government supervision and inspection, the methods and reports are necessarily uniform, and afford a means for comparative statements and statistical information, unexcelled by any in the world in precision and accuracy.

In the United States the interstate commission and the railroad commissioners of many states have, to a certain degree, exercised their power in the same direction, demanding yearly reports for publication. In the case of street railways, this information is only taken for purely statistical purposes, and, so far as the street railway interests are concerned, it could be very well dispensed with.

An English writer on this subject says:

"Uniformity in railway accounting in every respect is greatly to be

desired. Much has already been done in this direction, and the periodical reports of our English, Indian, Colonial and foreign railways under English control are models of completeness."

"There is, however, room for improvement. If the able administrators of American railroads could see their way to adopt a more uniform method of compiling their published accounts, setting forth the particulars of capital authorized, raised and expended, revenue earnings and disbursements, assets and liabilities on defined principals, and in a manner intelligible to any ordinary man of business, it would tend greatly to improve the value of sound railway securities."

This is recognized by every thinking man amongst us, especially those who have to do with the securities of our roads, and, yet, in the construction, equipment and operation of our tramways, we are far in advance of any country in the world, and English capitalists have not been slow to perceive this and demonstrate their faith in our work by investing in our street railway properties. Before doing so, they prefer to have the accounts examined by an independent auditor; as is the custom among themselves, nor can we blame them for this business-like proceeding, it has been instilled into them. Were there a more uniform system of reports and accounting, there is no doubt but that the stock and bonds of our wonderful street railroad properties would find an open market abroad.

The classification presented in 1884 was too elaborate for a small company, many directors and managers not caring for information in such minute detail, even on many of our largest and best equipped roads, there being 70 divisions of the operating expenses, while that submitted to you now has but 30, and even this might be simplified. The interests of this committee are first, last and all the time with the owners of the property, the stockholders and their directors, and by conjunction with the bankers who secure a market for their loans and with the bond purchasers.

These are the parties whose money and energy have built up our magnificent structures, and they should receive such information concerning the operation, earnings and expenditures as will enable them to know the value of their investment. The managers and superintendents occasionally look at these monthly reports and are pleased to carry them before the directors in person, if the totals make a good showing, otherwise they are apt to be mailed. Results are what they all want, and it matters but little to them whether the report is divided into 100 distinctive classes of receipts and expenditures, or ten. The road has earned a certain amount, and a certain percentage of that is irrevocably gone, and the sub-division of accounts could not have saved it. This might seem to be an argument in favor of the abolition of everything but the profit and loss account, but we do not go so far as that; we would advocate that the reports be much simplified, and that the standard be simple and concise enough for the smallest road, and the most conservative ideas. The stockholders and directors having invested their precious dollars with others in an enterprise, which has given every promise of noble returns in due time, are anxious to know the results from their venture and from time to time wish for a report which can be compared with those of other companies in the same, or similar fields. The banker, who has your bonds to put upon the market, asks for a statement of your earnings and expenses from the time the road was started. There is perhaps another road similarly situated and with a certain amount of capital, which to his knowledge has issued bonds to a certain amount and this road is not only paying the interest on those bonds but a certain dividend upon its stock. By a comparison of the reports of the two roads, he makes his calculations which are submitted to the dear public, and purchasers for the bonds are readily found. The creditors too, and their name is legion; the supply men, manufacturers of cars, electrical, cable and other machinery, are all interested in your financial reports; the lawyers, judges and receivers sometimes knock at the door for a copy of this valuable document. How necessary then that it should be all that is required of it. Who of all this list cares to go into the minute detail of a lengthy report? Very few, if any. These are the persons who take the greatest interest in our affairs, and they seldom have the time, or inclination to wade through the petty and cumbrous details. Who is it then that has served us this kettle of fish? None of the parties mentioned could have it laid at their door, they don't want it. We hold the divining rod in our hand, and it points to the auditor and accounting officer, the secretary and treasurer, the figure fiend, the statistician, assisted by those managers and superintendents who leave the road to work out its own salvation, while they record its progress or degeneration, as the case may be. Statistics costing us thousands of dollars per year, laid away upon the shelf to gather the dust of ages, and after years of repose, finally consigned to the flames. These statistical fiends appear to believe their only security is in being surrounded with

such a mystery and maze of figures, as will cause their colleagues to hold up their hands in amazement that any human being can exist in an atmosphere of such dense knowledge and remain perfectly sane. Don't understand this committee to imply that all accounting officers are of this class, there are some of them who belong to the same as this committee and are perhaps too lazy to produce so much fire and perform such intricate work, but so long as the stockholders require nothing better we are secure. In making tests our managers often require statistics as to mileage made by special gears, brushes, truck, wheels, trolley wheels, and much other similar information. This is perfectly proper and necessary at times for the good management of the road, but it is a side issue and not to be considered in making up our standard forms.

Not only should we seek uniformity in our reports, but in our methods as well. For instance, we find from the sample pages of some of the account books sent the committee, that it is the custom on some roads, when a bill is paid, to charge it to the account for which the material was used, while on other roads, the charge to expense is made when the material is received, and by others when it is used. This committee holds that the latter is the only correct method, as when material is purchased or paid for, we are simply making an exchange of cash for another form of assets, and there is no expense until the material is used. As an illustration of the incorrectness of the first method, let us take a road which should do a splendid summer business, and during the month of August there is a county fair which makes that month the best of the year. Then, we will suppose, that in the early summer they purchased enough supplies to last them several months, amounting to several thousands of dollars, and the bills all fall due, or are paid, in August; by this method the charge for several months' expense all goes into the expense, of one month. In consequence of such methods the report for August will be very misleading, and whereas it should show up as the best in the year, it is a question if it is not the worst. Charges to expense should be made as closely as possible in the months to which they belong. When we are of one accord on matters like this and can agree upon a classification, the balance of the work of standardizing forms of accounting will be very easy and soon accomplished.

There is but one other point upon which the committee wishes to touch, and that is the construction and equipment accounts. There is a great temptation for managers whose roads are running down on account of bad times, no travel, poor motors, bad track (all of course due to the mismanagement of his predecessor) we repeat, a great temptation to steer as many items as possible into the construction and equipment account. This is downright fraud, but it is done nevertheless.

Nor are the managers and accounting officers wholly to blame for this. Many of the roads are too heavily capitalized in the start, contracts are let with a huge profit for some one, and the road gets whatever may fall to its lot, sometimes only the broken crust. With a capital stock of \$2,000,000, it could be paralleled by a better road, with better equipment for perhaps half the money. Next comes the bonds to the amount of another couple of millions and secured by a mortgage upon the property.

Half built in the first place, and with inferior equipment and with the interest on the funded debt of more than the entire cost of the road, perhaps the officials of the company think that the game must go on, and that the particular part they are to play is to bluff it as long as possible until the receiver calls time.

The committee might dwell at length upon the distinction between the transportation charges and the maintenance charges which were found to be somewhat confused on many of the reports sent in response to our request, but time is too short.

We will say in conclusion, having carefully examined the blank forms and statements sent us, that forty per cent are practically the same as the reports used by the committee, and correspond in general detail with the classification submitted to you.

Thirty per cent have practically the same headings, but in each there are instances where expenditures upon the property or maintenance charges are mingled in a confused way with those expenditures which add nothing to the property either present or future.

In 5 per cent the items are grouped under distinctive headings, but with no regard to the divisions as generally used.

In 25 per cent, although the accounts might be sub-divided to a considerable extent, and some of them have very elaborate statements, the grouping into distinct classes is entirely ignored.

From this you may see that should the association adopt the classification submitted, 30 per cent of the roads would be all right as they stand, and 40 per cent more would need to change but two or three items, principally putting the repairs of the power plant under the same head as repairs of the balance of the equipment where it undoubtedly

belongs. Twenty-five per cent more would but need to arrange their accounts systematically, instead of having them in a jumbled state, as most of them have the charges made to the proper accounts, but not arranged systematically in the reports.

Nearly 40 per cent of those replying to the circulars sent out by the committee expressed their approval of the classification sent them, and also a desire that it should be adopted by the association and none expressed disapproval.

CLASSIFICATION OF EXPENDITURES FOR STREET RAILWAYS.

Construction and Equipment.	}	1.— Superintendence and organization.		
		2.— Engineering.		
		3.— Right of way.		
		4.— Building construction.		
		5.— Track and roadway construction.		
		6.— Overhead line construction.		
		7.— Car equipment.		
		8.— Snow plows and sweepers.		
		9.— Power station equipment.		
		10.— Tools and machinery.		
		11.— Improvements and betterments.		
		12.— Real estate.		
General Operating Expense.	}	21.— Salaries general officers and clerks.		
		22.— Miscellaneous Ex. general offices.		
		23.— Insurance.		
		24.— Legal expense.		
		25.— Injuries and damages.		
		26.— Contingent expense.		
		27.— Park properties.		
Transportation Expense.	}	28.— Car service.		
		29.— Car house expense.		
		30.— Lubricants and waste for cars.		
		31.— Supplies.		
		32.— Wrecking.		
		33.— Operating power house.		
		34.— Fuel.		
Operating Expense.	}	35.— Lubricants and waste for power house.		
		36.— Water.		
		37.— Hired power.		
		Maint. of Way and Buildings.	}	38.— Repairs roadway and track.
				40.— Renewals of rails.
				41.— Renewals of ties.
				42.— Repairs and renewals paving.
43.— Repairs and renewals supply, wires.				
Maint. of Equipment.	}	44.— Repairs and renewals bld'gs, docks, etc.		
		45.— Repairs and renewals overhead lines.		
		46.— Repairs of cars.		
		47.— Repairs of electric equipment.		
		49.— Repairs of steam plant.		
		50.— Repairs of electric plant.		
		51.— Repairs of tools and machinery.		
		52.— Miscellaneous expenses.		

The classification as given here is not subdivided to the extent that some might think desirable, but sufficiently for any practical purposes, as any further division would be purely statistical.

There are two principal divisions of expenditures, viz: 1. Construction and equipment. 2. Operating expenses. The latter is divided into four groups: 1. General operating expense. 2. Transportation expense. 3. Maintenance of way and buildings. 4. Maintenance of equipment.

The construction and equipment charges only include expenditures which add to the original value of the property.

The first two divisions under the head of operating expense i. e., general operating expense and transportation expense, include only such expenditures as are necessary for operating the road, while the other two divisions, viz: Maintenance of way and buildings and maintenance of equipment, include all expenditures made upon the property itself, necessary to keep it in perfect repair.

These maintenance charges are purely operating expense, but are essentially different from the first two divisions of the operating expense, in that they add materially to the present or future value of the property, while the general and transportation charges do not.

The classification, as presented, is especially prepared for electric railways, but can be easily adapted to use on cable, horse and steam

roads, in fact, has been used successfully on a combination of electric, horse and steam roads.

For use upon horse roads.—All the subdivisions of general operating expense would be the same.

Under the head of transportation expense, for No. 31 would be substituted supplies, including miscellaneous supplies, such as are constantly needed for the operation of horse cars, and could not be chargeable to repairs.

For No. 33 would be substituted stable expense, including wages, stablemen and hostlers.

For No. 34—fuel—would be substituted provender and bedding.

The latter expense in each case being that in horse roads, which is offset by the corresponding expense on electric roads.

Proceeding, we would find that the subdivisions under the head of maintenance of way and buildings are all right for horse railways, except that No. 43 and No. 45 would be omitted.

Under the head of maintenance of equipment, instead of No. 47, No. 49 and No. 50, we would have—renewals of horses, repairs and renewals of harness, shoeing, veterinary services.

To adapt this classification for use on suburban steam roads we would have the general operating expense the same.

Under the head of transportation expense, No. 28 would not include the wages of engineers and firemen—only conductors and brakemen—and for No. 33 would be substituted locomotive service, this being the corresponding expense to operation of power house.

All others would remain unchanged, except that No. 35 would be lubricants and waste for locomotives, instead of power house, and No. 37 hired power would be omitted.

Under the head of maintenance of way and buildings no change would be necessary, except that, as with horse roads, No. 43 and No. 45 would be omitted.

Under the head of maintenance of equipment, for No. 47, No. 49 and No. 50 would be substituted, repairs of locomotives.

Having had no experience with cable roads, the committee cannot say just what substitution would be necessary, but feels very confident that the same classification could easily be adapted for use upon such roads as well.

CONSTRUCTION AND EQUIPMENT ACCOUNTS.

Too much care cannot be exercised in charges to these accounts. Nothing should be charged to Construction and Equipment except that which adds to the first or original cost of the property.

1. Superintendence and Organization Expense.—Salaries of superintendent of construction, assistants, wages of clerks and others employed in the offices of this department. Expense of the office, furniture, fuel, lighting, supplies for office, miscellaneous and personal expense of superintendent and assistants while on business. Includes stationery and printing for this department. Also all expenses of organization not coming under either of the following heads:

2. Engineering.—Wages and expenses of engineers and draughtsmen on preliminary and construction work.

3. Right of Way.—Salaries and expenses of right-of-way agent, together with payments for rights of way, easements, franchises and pole rights.

4. Building Construction.—Cost of buildings, car houses, stations, offices, store houses, power house, repair shops, wharves, coal sheds, etc., etc.; also furniture and fixtures for the same.

To this account should also be charged the cost of land occupied by the buildings mentioned.

Real estate (land and buildings thereon) not used by the road for actual operation must be charged to real estate account.

5. Track and Roadway Construction. Includes the expense of grading, surfacing, ballasting, ditching and paving; the cost of rails, rail chairs, ties and stringers, tie rods, joint fastenings, track spikes, frogs and switches, supplementary wire, tie wires, channel pins, solder and miscellaneous track material; also the cost of distributing and laying the same, with the supplementary wire and its connection.

6. Overhead Construction.—Cost of poles and setting; putting up trolley, feeder and guard wires, including cost of wire and all devices for overhead construction.

7. Car Equipment. Cost of cars built or purchased, including the cost of trucks, wheels, motors, upholstering, painting, lettering, varnishing, etc.

8. Snow Plows and Sweepers.—Cost of snow plows and sweepers built and purchased, including the electrical equipment for the same.

9. Power Station Equipment.—Cost of steam plant, engines, boilers, pumps, piping, shafting and belting, dynamos and switchboard

equipment, together with installation of the same.

10. Tools and Machinery.—Cost of tools and machinery for repair shops, car houses, etc., and expense of setting and placing in running order.

11. Improvements and Betterments.—All expenditures which improve the original plant, and of which a portion should be charged to operating, and a portion to construction expenses.

12. Real Estate.—All land and buildings thereon purchased as an investment and not used by the road for actual operation.

#### GENERAL OPERATING EXPENSES.

21. Salaries of General Officers and Clerks.—In this account are included the salaries of the general officers; the heads of departments connected with the supervision and management of the general business of the road. Salaries of division superintendents and assistants may also be charged to this account.

By general officers are meant officers in charge of departments, and whose jurisdiction extends over the entire road.

This account embraces the salaries of all clerks in the general offices, clerks for heads of departments, and all clerks not hereinafter mentioned.

22. Miscellaneous Expense General Offices.—The expense of heating and lighting the general offices; wages of porters, messengers, etc.; telephone service and all miscellaneous supplies and expenses of the general offices, including the cost of all stationery, books, paper, stamps, pens, pencils, etc.; also cost of all printing of blanks, circulars, statements, tickets, and the cost of advertising.

23. Insurance.—Includes cost of insurance on property of the company, and against injury to employes, and all expenses of collection.

24. Legal Expense.—In this account are included the salaries, fees and expenses of attorneys, witness' fees and other court expenses.

25. Injuries and Damages.—Expenses on account of persons injured, and property damaged, with payments of claims are all chargeable to this account.

Wages of persons while disabled, medical attendance and funeral expenses; also wages of claim agent and others connected with the claim department.

Lawyers' fees and other court expenses are not chargeable to this account; nor are damages to property belonging to the company.

26. Contingent expense.—This account includes the miscellaneous expenses not otherwise provided for. Traveling and other expenses of general officers and assistants, etc., etc.

27. Park Properties.—Includes all running expenses of parks owned or leased by the company.

#### TRANSPORTATION EXPENSES.

28. Car Service.—This account includes the wages of conductors, motormen, starters, aids, inspectors and switchmen; cost of punches, ticket registers, sign sticks, switch sticks and miscellaneous supplies for car service.

The wages of the superintendent of time tables, and chief of conductors, with such clerks as may be under them, should also be charged to this account.

29. Car House Expense.—This account includes the wages of shed foremen, shifters, cleaners, oilers, wipers, laborers, inspectors and watchmen, except such as are employed on repairs of cars.

The cost of fuel, and lighting the car houses and sheds, lanterns and oil for watchmen, tools used by workmen on cars, (cleaning and oiling, and other work except repairs,) are chargeable to this account.

30. Lubricants and Waste for Cars.—Oil, grease, tallow and other lubricants with waste used upon car journals and motors are included in this account.

31. Supplies.—This account includes such supplies as are constantly needed for the operation of the electric cars, but cannot be charged to repairs, such as:—Lamps, fuses, carbon brushes, trolley cord, etc.

32. Wrecking.—Wages of those employed in getting derailed cars on the track, and removing obstructions and wrecks; tools used and all other expense incurred on the same account.

Expense of getting cars back to the car house when broken down on the line, is also chargeable to this account.

33. Operation of Power Houses.—This account includes wages of engineers, firemen, coal shovellers, dynamo men, oilers, cleaners and others employed in the power houses, except when employed upon repairs.

Also the cost of water, water rates, or cost of pumping where the company furnishes its own water works; carbon brushes, fuses, lamps

and other supplies necessary for the daily operation of the power houses, and not otherwise provided for; cost of heating and lighting power houses.

Repairs and renewals of engines, boilers, dynamos, switch-boards and station fixtures are not chargeable to this account. Fuel and lubricants are also chargeable to separate accounts.

34. Fuel.—This account includes the cost of all fuel used in the power houses, with transportation charges on the same.

35. Lubricants and Waste for Power Houses.—Oils, greases, tallow and waste for use in the power houses, for engines, shafting, dynamos, pumps, etc.

36. Water.—Cost of water when taken from local water works companies.

37. Hired Power.—Cost of power when taken from other electric companies.

#### MAINTENANCE OF WAY AND BUILDINGS.

38. Repairs of Roadway and Track.—This account includes all expenditures on account of the roadbed and track, except the cost of rails and ties used, and the cost of repairs and renewals of paving, and the supplementary wire.

It includes tracks laid in buildings, yards, on turntables, wharves, and over bridges; wages of roadmasters, track foremen, laborers, watchmen, and others, while engaged in track repairs and renewals.

It includes cleaning, oiling and sanding track, repairs and renewals of drains under the track, repairs and renewals of planking over bridges, repairs and renewals of frogs and switches, joint fastenings, etc., etc. It also includes repairs of rails, and all work on rails, cutting and drilling, except drilling for tie wires. Also labor expended in taking up track.

The cost of tools, implements, and all supplies used in connection with the track are included in this account.

The expense of removing snow and ice, with the cost of repairs on snow plows and sweepers, may be made a separate account if so desired, but comes under the head of Maintenance of Way.

40. Renewals of Rails.—This account includes the cost of new rails laid in the track, with the transportation charges on the same, less the value of old rails taken up.

The expense of loading, unloading, drilling, cutting, laying and repairing rails is not included in this account.

41. Renewals of Ties.—This account includes the cost of new ties laid in the track and the freight on the same.

The expense of loading, unloading and laying ties is not included in this account.

42. Repairs and Renewals of Paving.—This account embraces all expenditures on account of the paving.

It includes the cost of paving blocks and sand, and the cost of transportation of the same; the wages of pavers, laborers and others, engaged in repairs and renewals of paving; also the cost of tools and other supplies for the same work.

The expense of taking up and relaying paving when necessitated by the repairs on the roadbed, the track and the supplementary wire is not chargeable to this account, but to the account for which expense was incurred.

43. Repairs and Renewals of the Supplementary Wire.—This account includes all expenditures on account of the supplementary wire and its connections.

It includes the cost of the wire, tie connections, channel pins, solder, and other supplies, also tools and implements used in connection with the work of repairing the supplementary wires; wages of solderers, laborers and others engaged upon this work.

The expense of drilling rails for channel pins and tie wire rivets, is also chargeable to this account.

Expense on the supplementary wires, necessitated by the taking up of rails, ties, switches, frogs, etc., is not chargeable to this account, but to repairs of roadway and track.

Expense on the supplementary wires necessitated by the taking up or laying of paving should be charged to the account of paving.

44. Repairs and Renewals of Buildings, Docks and Wharves.—This account includes the cost of repairs and renewals of all buildings, docks and wharves, and of the stationary fixtures and furniture of the same, not otherwise provided for; car houses and sheds, store houses, car shops, repair shops, blacksmith and machine shops, power houses, coal sheds and bins, stations, etc., etc.

Repairs of pits in car houses and shops, cranes in power houses and coal sheds, etc., are embraced in this account.

Repairs of tracks in buildings and on wharves, are not chargeable to this account.

45. Repairs and Renewals of Poles and Overhead Lines. This account includes the cost of repairs and renewals of poles and brackets, with trolley, span, guard and feed wires, with all appliances for suspension and insulation of the same.

#### MAINTENANCE OF EQUIPMENT

46. Repairs of Cars.—This account includes the cost of all repairs on car bodies, painting, varnishing, upholstering, re-lettering cars and car signs; repairs and renewals of the trucks, brakes, brake shoes, axle boxes, springs, track brushes, snow scrapers, pilots, sand boxes, etc.; repairs and renewals of wheels and axles.

The cost of new cars taking the place of old to make the number good, are also chargeable to this account.

On roads using both motor and tow cars, it is sometimes advisable to keep each kind separately.

47. Repairs of Electrical Equipment.—This includes the repairs of motors, their parts and connections, the labor of removing damaged parts and replacing same when repaired.

Armatures, fields, gears, pinions, controllers, switches, trolleys, lightning arresters, brush holders, cables, etc., all come under this head.

New motors or parts purchased or made and put in to replace those damaged or worn out must be charged to this account also.

49. Repairs of Steam Plant.—To this account should be charged all repairs and renewals of the steam plant in the power house, including the boilers, engines, pumps and shafting, repairs and renewals of belts, piping, steam fitting, etc., etc.

50. Repairs of Electrical Plant.—Repairs and renewals of dynamos and their parts; armatures, fields, pulleys, commutators, oilers, bearings and boxes, brush holders, etc., are all chargeable to this account; also labor removing and replacing damaged parts.

Repairs and renewals of the switchboard equipment are also charged to this account, such as repairs and renewals of station switches, rheostats, circuit breakers, ammeters, wiring and connections.

51. Tools and Machinery.—Repairs and renewals of tools and machinery, shafting, boilers, engines, etc., in the shops of the company; also cost of lubricants for the same.

Small tools (not shop fixtures) are chargeable to the account most benefited by them.

52. Miscellaneous Expenses.—To this account should be charged all miscellaneous expense of maintenance of equipment, not otherwise provided for.

THE White-Crosby Company, of Baltimore, has been awarded the contract for the subways for the police and fire alarm telegraph system of Baltimore. The White-Crosby bid was for terra cotta conduits of the "Camp" class. The accepted bid was not the lowest. The contract was let on the grounds of the excellence of the designs submitted, which corresponded most nearly with the specifications. The White-Crosby Company is certainly to be congratulated on its victory in the face of such strong competition. Five bids were submitted.

W. A. BOGARDUS has resigned as general manager of the Brooklyn Heights Railroad Company, and has been elected secretary and treasurer in place of Cyrus P. Smith, resigned on account of ill-health. A saving of 1 per cent on capital stock has recently been made by reducing salaries of officers from president down.

THE Electric Club of Cleveland has elected the following: President, Charles W. Wason; vice-presidents, B. M. Barr, and T. E. Adams; secretary, H. J. Davies; treasurer, E. W. Moore; board of managers, the officers and R. M. Fuller and George W. Cleveland.

#### FAST TIME ON THE BRIGANTINE ROAD.

In our issue of September, 1893, we gave a full description of the Brigantine Transit Company's new line, and mention was made of the peculiar form of cars used and the high speed for which the motors are wound. Superintendent Joseph T. Skerrett writes us of some of the fast time made in actual practice. On account of top heaviness on the trestle, the double deck cars have had the upper deck removed. These cars, it will be remembered, were 38 feet long, mounted on double trucks, with a W. P. 50 motor to each truck. When the upper decks were removed, one motor was taken off each car, leaving but a single motor to the car. The reconstructed cars weighed 23,000 pounds each. As a trial, one of the reconstructed cars ran a measured mile of 5,280 feet, with twenty-seven persons aboard, in one minute, forty-two seconds, including the start from a dead stop, and a full stop at the end. This car has also run  $3\frac{1}{8}$  miles in six minutes, including one stop to throw a switch, a slack up at siding switches, and two dead stops for passengers. The miles were measured in this case also. The regular schedule time from one end of the road to the other ( $6\frac{1}{4}$  miles) is twenty-one minutes, including four stops. This is an average of nearly 18 miles an hour. When behind time cars have made the trip in  $13\frac{1}{2}$  minutes. This is certainly pretty fast running for single equipments.

#### HOW THEY HANDLE THE HOUSE-MOVER AT LINCOLN, NEB.

A house-mover, at Lincoln, Neb., recently seemed determined to get himself into trouble, but was finally subdued by the efforts of C. C. Upham, general manager of the Lincoln street railway. The mover started the house out on to the tracks in the daytime, and declared that he was going down street at all hazards. The street railway obtained a restraining order from the court, stopping him with his house partly in the street and partly on the lot. A deposit was then exacted from him of \$25, to cover the labor of the street railway linemen who should help him during the night. He further agreed that he would do the work entirely at night, between the hours of 12 and 6 A. M., as was originally demanded. Having obtained this agreement, the company asked the court to modify the restraining order in such a way as to permit the house-mover to move his house between the hours of 12 and 6 A. M., and ordering him to work each consecutive night until the house should be clear of the tracks, not allowing him to stop during the moving. The case was set for trial, and under the modified order of the court the mover worked two nights, got his house off the track, and the case was dismissed at the cost of the mover, so that he finally paid not only for the linemen's work, but the small additional court costs. This is the first case of house moving which has given any trouble in Lincoln. Ordinarily, the house movers give notice that they wish to move a house on a certain night, and the linemen collect for their labor at the rate of one and a half times their regular wages.

## A COMMUNICATION.

EDITOR STREET RAILWAY REVIEW:

In the September REVIEW I noticed an editorial claiming the very economical operation of a small electric road viz: 13 cents per car mile per day. Allowing they run 5 E. M. C., 16 hours per day, and average 7 miles per hour or a total of 540 miles, their operating expenses would be about \$70 per day. What proportion of this is power, labor, maintenance, etc., etc. I would like to get the items making this total. I am interested in a road of 5 1-6 miles and using 5 E. M. C., and our figures are very different.

Yours Truly,  
A. B.

The items which go to make up the operating expense referred to are not now before us and in view of another article published this month on the operating expenses of another road, which range from 7 to 8 cents per car mile, it will hardly be necessary to inquire into the figures of the 13 cent road.—EDITOR.

### OPERATING EXPENSES OF THE BEAVER VALLEY TRACTION COMPANY.

An editorial mention was made in the September REVIEW, of a small road, not operating under very favorable conditions, which showed operating expenses of 13 cents per car mile. As a small road is always at a disadvantage over a large one as regards operating expenses, and as this record, compared favorably with many large systems, we were amply justified in considering it a good one. The editorial in question has stirred up the brethren, however, so



H. P. BROWN.

that we are able to show some figures that nearly cut in two the 13 cents record.

Hartford P. Brown, general manager of the Beaver Valley Traction Company, of Beaver Falls, Pa., makes to us a detailed report of the operating expenses of that road per car mile for the past year. The very fact that he is able to make this detailed statement would be proof to any one acquainted with such matters that the road is in good hands even before they learned how good the record was. For the months of January and August, 1894, the operating expenses were as follows:

ITEMS.	JANUARY, 1894.	CENTS PER CAR MILE.
1. Car service, motormen and conductors.....		3 516
2. " house service.....		589
3. " supplies.....		068
4. Power house wages.....		577
5. Fuel.....		402
6. Oil and waste.....		040
7. Water rent.....		048
8. Car repair material (not electrical).....		140
9. " " " (electrical).....		394
10. Power station repair material.....		018

11. Track repairs.....	284
12. Building repairs.....	127
13. Line repairs.....	—
14. Office expenses.....	741
Total.....	6,884

#### AUGUST, 1894.

1. Car service, motormen and conductors.....	3 442
2. " house service.....	759
3. " supplies.....	015
4. Power house service.....	515
5. Fuel.....	406
6. Oil and waste.....	019
7. Water rent.....	047
8. Car repair material (not electrical).....	335
9. " " " (electrical).....	354
10. Power station repair material.....	137
11. Track repairs.....	298
12. Building repairs.....	—
13. Line repairs.....	019
14. Office expenses.....	675
Total.....	7 021

The monthly expenses for the year are as follows:

July, 1893.....	8 8 cents
Aug. ".....	8 5 "
Sept. ".....	7 8 "
Oct. ".....	8 5 "
Nov. ".....	9 7 "
Dec. ".....	8 0 "
January, 1894.....	6 8 "
February ".....	7 5 "
March ".....	7 9 "
April ".....	7 9 "
May ".....	8 "
June ".....	8 2 "
July ".....	7 7 "
August ".....	7 0 "

Mr. Brown is willing to back up these figures by allowing an inspection of the books by proper parties or by affidavit. The road operates nine cars during week days from 8 a. m. to 8 p. m., and five cars the balance of the running hours. On Sundays six cars are run until noon, nine until 8 p. m., and five until 11 p. m. The system is three years old. During its first year the operating expenses were 12.5 cents a car mile. At the end of the first year Mr. Brown took charge and has finally succeeded in reducing expenses to the above figures. It is safe to say that the public is as pleased with the management as are the stockholders—at least Mr. Brown is willing to let the verdict rest with the public. The wages paid conductors and motormen are 15 cents an hour.

THE contract for building 7½ miles of track for the Danbury & Bethel, Conn., Horse Railway Company, has been awarded to Wardell Brothers, of New Haven.

THE Pottsville, Pennsylvania, Traction Company, which proposes to build 36 miles of electric line from Tamaqua to Pottsville, St. Clair, Port Carbon and Frackville, is having a contest with the Schuylkill Electric Railway Company, which has franchises on all the best streets in Pottsville and has been trying for franchises in other towns. The Pottsville company has secured franchises from St. Clair, New Philadelphia and Tamaqua, which require the road to be running within a year.

## CLIFFORD L. SNOWDEN.

It is with regret the REVIEW parts with the services of one of the most faithful members of its editorial staff, Clifford L. Snowden, who has been connected with this mag-



CLIFFORD L. SNOWDEN.

azine for nearly four years. He now resigns only to carry out a long cherished plan, and has already entered upon a two years post graduate course, mainly along sociological, economic and psychological lines. He will not drop journalistic work entirely, but will continue a frequent contributor to the REVIEW, and several other publications. Mr. Snowden is a ready, racy writer, not only of prose but of verse and

humor. Many a little poetic gem has flowed from his facile pen. He is a young man, younger than many have supposed, and has made a record with the REVIEW of which he may well feel proud.

It is a pleasant duty to thus bear testimony to faithful, able service, which has ever been ready, willing and untiring. To a large number of the street railway fraternity he is well known personally and all will join the REVIEW in most hearty wishes for his success and happiness, and when he has quaffed the fountain of advance studies may he return to us again.

So here's to your health Clifford, and may you live long and prosper.

H. H. W.

## MARRIED.

Frank S. De Ronde, of the Standard Paint Company, of New York City, was married, October 11, to Miss Kate W. Bennett, at the residence of the bride's parents, Teaneck, Englewood, N. J.

## WAUKESHA ROAD SEEMS ASSURED.

The promoters of the new electric railway at Waukesha, Wis., have succeeded in arousing public enthusiasm. As the result of their energetic efforts subscriptions to the capital stock of the company have come pouring in from solid business men of the city. Already there has been subscribed \$25,000 of the required \$40,000, although only two weeks had elapsed since the subscription books were opened. Tracklaying will, it is said, commence before snow flies. But for the push and enthusiasm of the originators the construction of an electric railway in Waukesha would have been delayed indefinitely, perhaps for years.

## THE WELLS &amp; FRENCH COMPANY TO BUILD STREET CARS.

The reputation of the Wells & French Company, of Chicago, as a builder of railway cars is sufficiently well known, and the company needs no introduction. The public will be greatly interested to know that this company has just finished a shop 100x300 feet, solely for the purpose of building street cars. An additional force of draughtsmen and skilled mechanics in this particular branch of car building has already been engaged. If occasion should require, the whole complete plant of the Wells & French Company could be utilized to build street cars. The trucks and metal work will be done in the present large machine shop. A large stock of well-seasoned lumber is always kept on hand to fill orders promptly. The finishing department has facilities to execute the most elaborate car interiors, and is capable of satisfying the most artistic tastes. The Wells & French Company has been in business for 35 years, and its long experience in car building will be a guarantee to prospective purchasers of the superiority of its work. The factory is situated near Blue Island avenue and Paulina street, within easy reach from the city, and covers 27 acres of ground. The sales offices are on the twelfth floor of the Monadnock building, under the direction of E. F. Carry, Jr., who is well known to all street railway men. Augustine W. Wright, who is a well-known authority on street railway matters throughout the United States and abroad, and who is well known to the general public through his contributions to street car literature, and who has been identified with the Wells & French Company for many years, is its consulting engineer. The company is backed up by an almost unlimited capital, and will undoubtedly make its new departure as great a success as its former undertakings.

THE Cortland & Homer Traction Company, Cortland, N. Y., has closed contracts for its entire equipment. Specifications were drawn and contracts placed under the direction of Prof. R. C. Carpenter, of Cornell University. Four compound condensing Watertown engines with pumps, condensers, heaters, and four 100-horse-power boilers manufactured by the Watertown Steam Engine Company, Watertown, N. Y., will be installed.

E. E. DOWNS, superintendent of the Citizens' Street Railway Company, Kalamazoo, Mich., has resigned. He has accepted the management of the new street railway at Battle Creek, Mich., and will have charge of the construction of the road at Battle Creek, which, it is expected, will be in operation early in January.

WAREHAM & HUGHES, Beaver, Pa., have secured the contract for the road to run 15 miles from Benwood to Moundsville. They bid \$200,000.



VIEWS OF THE WELLS & FRENCH STREET CAR FACTORY, CHICAGO.

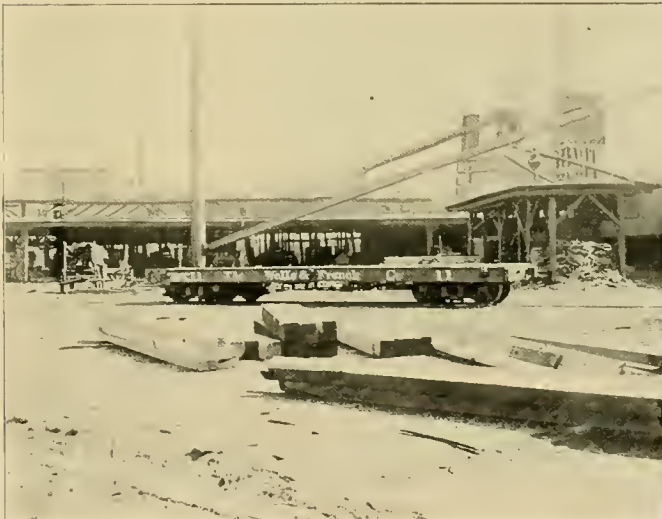
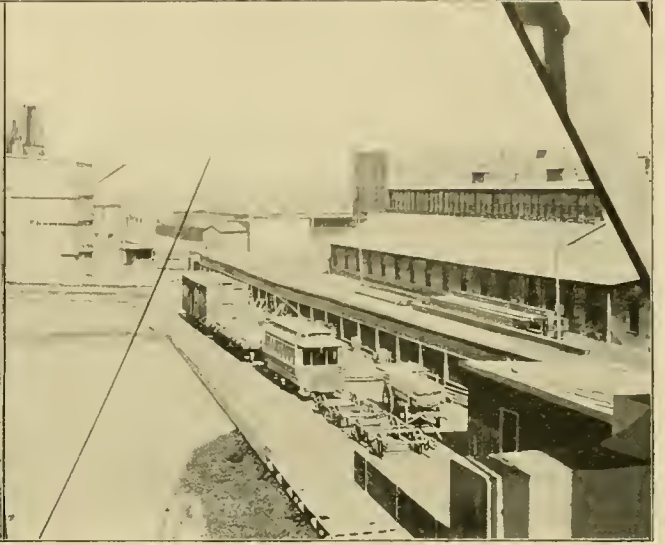
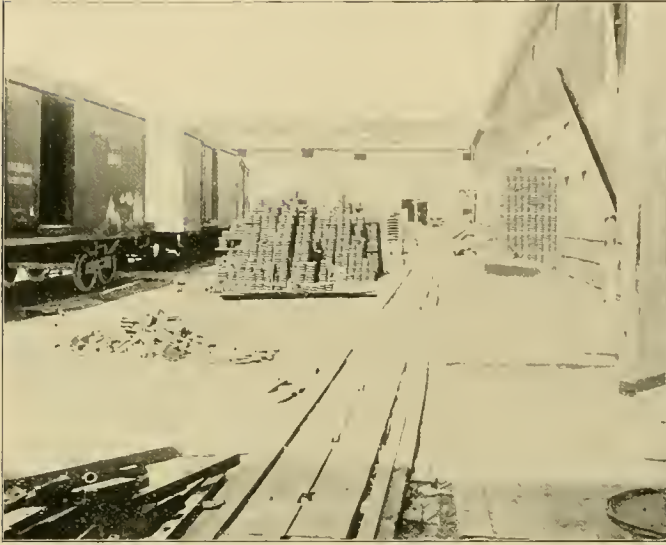

## THE WALKER STREET RAILWAY MOTORS.

The Walker Manufacturing Company of Cleveland, completed its first street car equipment about July 1, 1894. The fortunate road which received the first consignment was the Hoosic Railway of Hoosic Falls, N. Y., which received three equipments, together with a 200-horse-power generator to be driven by water power. The road was installed by J. H. Vail of the Electrical & Mechanical Engineering and Trading Company. Both the street railway and the construction company are greatly pleased with the motors performance and do not hesitate to make public utterance to that effect. Indeed it was certainly to be expected that the motors would give satisfaction, as they were backed by a manufacturing company of widest reputation as well as by a remarkably good mechanical design. The Walker Manufacturing Company has also furnished the entire equipment for the Althol & Orange Electric railway of Orange, Mass., where they have been giving good results under heavily loaded open trailers. The Passaic & New-

ark Electric Railway Company also has the Walker equipments. This is a road of numerous steam road crossings and consequently the Walker spring suspension

has an excellent chance to show its good qualities. The crossings are run over with remarkable freedom from hammer blows. The spring suspension also has a tendency to prevent disagreeable rumbling. These motors run 166 miles a day and come in cool at night although they are en-

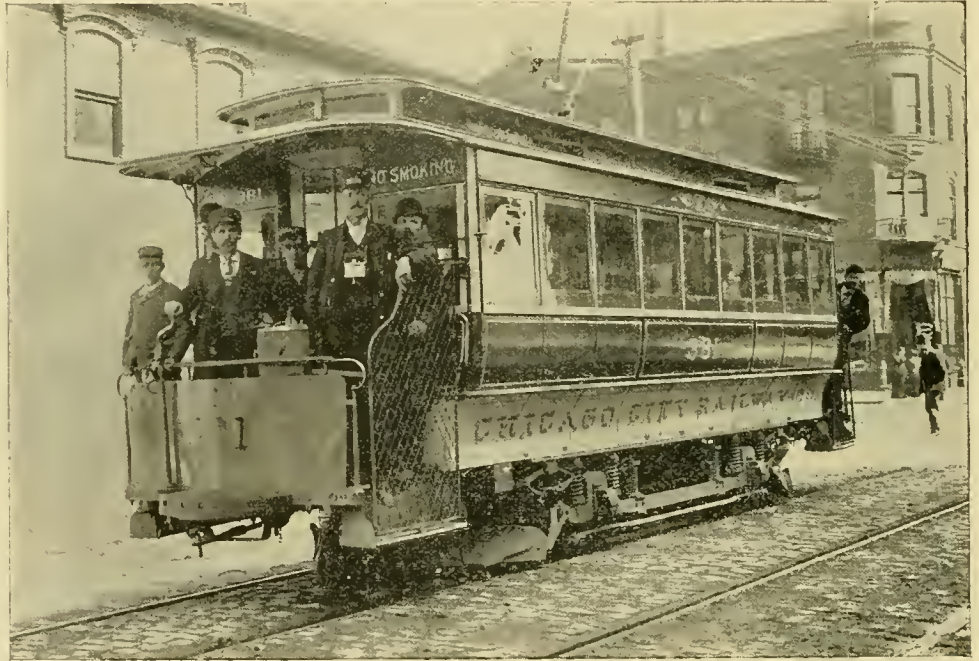

WALKER MOTORS—CHICAGO CITY RAILWAY.



WALKER MOTORS, AKRON.

ark Electric Railway Company also has the Walker equipments. This is a road of numerous steam road crossings and consequently the Walker spring suspension

tirely enclosed. The Tama & Toledo, Iowa, interurban mentioned elsewhere is also getting good service from Walker equipments. The Schuylkill Electric Railway of Pottsville, Pa., is being re-equipped and the standard 25-horse-power equipments have been running for some time under long open cars seating 100 passengers. The grades are as high as 12 per cent. Some 50-horse-power equipments have been ordered for high speed suburban service. One of the Chicago City Railway lines has had a Walker equipment for several months and not a trip has been lost by it. More have been ordered. The Akron, Ohio, Street Railroad, one of the first Sprague roads is being equipped with 25-horse-power Walkers. There is one grade on this road of  $11\frac{1}{2}$  per cent 1,000 feet in length. Superintendent W. D. Chapman says that he has taken

cars up that grade loaded with over 100 passengers and is delighted with the performance of the motors.

These few facts are published because the street railway fraternity will be interested in knowing that the company which so lately entered the railway field and which from the eminence of its technical staff and extent of its manufacturing facilities aroused great expectations is living up to the high standard expected of it.

The facilities of manufacturing the apparatus are unsurpassed in any factory in the United States. The factory covers an area of over 300,000 square feet, and is provided with ground which will permit trebling its capacity on short notice. It is already prepared to turn out ten street railway equipments per day, with the necessary generators to drive them. It is also going largely into the manufacture of industrial power transmitting machinery, such as generators and motors for machine shops and mills, as well as mining machines of all kinds. This

company is especially well fitted for making very large sizes of generators and motors. Plans and patterns are already out for 2,000 and 3,000-horse-power generators, and there are already under construction in the shop, machines ranging from 50 up to 1,000-horse-power. The machines are made to be belt driven for the smaller sizes, and direct coupled to engines for the larger sizes.

The Walker Manufacturing Company is known throughout the world for its excellent mechanical construction of machinery of all classes, and it is carrying out the same policy of mechanical construction in its electrical machinery, that it has practiced in the past in its cable railway machinery and other classes of work. The introduction of excellent mechanical construction, design, and workmanship, into electric machinery is an absolute essential which is often neglected.

FARMER OATES was taking his first ride in a Buffalo trolley car. When the conductor passed transfer checks, the farmer was overlooked. He amused his fellow passengers by shouting, "See hyar, conductor, ye didn't give no receipt for my nickel."

THE recent health congress at Montreal, recommended the thorough cleaning of floors and cushions of cars. During the famous small pox epidemic, several years ago, in that city, it was said it was safer for citizens to be in the street cars than in their own homes, for the former were fumigated every trip.

## MICANITE FOR COMMUTATORS.

In making or refilling commutators, it is sometimes necessary to apply heat while building, and it often results that bars become loose, cement oozes out, or the oil soaks in. It is claimed these difficulties are avoided by using Micanite

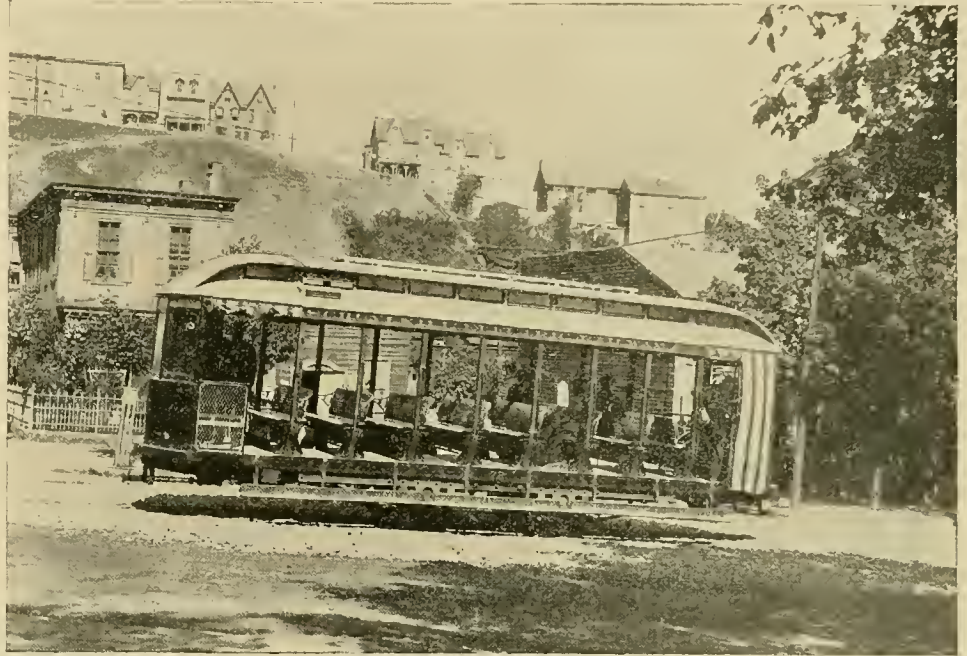

WALKER MOTORS—SCHUYLKILL ELECTRIC RAILWAY

segments or rings, manufactured by the Mica Insulator Company, of 218 Water street, New York. To apply the Micanite it is only necessary to proceed as follows: After assembling the commutator, heat it to about 200° Fahr., when the Micanite will soften. Then tighten the bars or rings as much as possible. The pliability of the Micanite will allow the distribution of unequal strains, and will counteract, to a great extent, any irregularities in the dimensions of other parts of the commutator. Continue the application of heat until the temperature has risen to 400° Fahr., or until the shellac, which will have oozed out here and there, has become dry. No bad results will follow, even though the shellac be partially carbonized. Wait until the shellac is baked dry before retightening, which may be done while hot or cold, but preferably in both states.

The heating of the commutator presents no difficulty, even where proper arrangements are not at hand. The commutator may be placed for a few minutes inside the door of a boiler furnace, upon a gasoline stove, or upon a plate placed over a blacksmith's forge.

THE Electric Switch & Trolley Company, Newark, N. J., has been incorporated with \$500,000 capital by Emile Rieser and Joseph Campbell, New York, and George W. Littell, Crawford, N. J., incorporators. The company proposes to acquire patents for electrical improvements and to sell and manufacture electric switches, motors and cars.

### THE JEWELL TROLLEY SLING.

A rather peculiar method of avoiding the disastrous hammering effect of the trolley head on the insulators of bracket and center pole construction is embodied in what

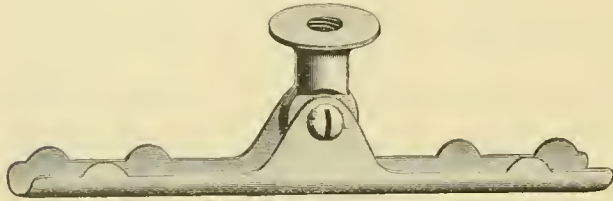

JEWELL TROLLEY SLING.

the makers designate as the Jewell trolley sling. Arrangements for manufacturing it have been made by the Ohio Brass Company. The lug into which the hanger stud is threaded is swiveled in the body of the ear so as to admit of an oscillatory motion when the trolley wheel passes under it. This it is claimed eases the motion of the wheel so that there is very little hammering. In putting them on the wire the swivel bolt is taken out and the lug removed. The wire is put in the groove and the lips which are shown in the side view are bent over it to hold it in place. The lug and bolts are then replaced and the ear fastened to the insulator. No soldering or special tools are required and these slings can be put up very quickly. Its standard length is nine inches, and a composition brass metal is used.

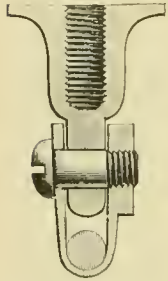

### THE EMPLOYEES CONVENTION.

The third annual convention of the Amalgamated Association of Street Railway Employees, was held at Milwaukee, the week of October 8. Forty-two local unions having a membership of 30,000 were represented. The most startling business transacted was the expulsion on account of mismanagement, of William J. Law, the first president, for 99 years; at the end of that period he may be reinstated, but it is doubtful, if, when he makes application, it will be found that "the punishment fits the crime." It was decided to make a strike the last resort in case of a difference between employer and employe. This will make it necessary for each local union to hereafter submit its strike resolutions to the executive council of the association, and secure its sanction before declaring a strike. The per capita tax was reduced from 8 to 7 cents. Headquarters will be Detroit. The officers are: President, W. D. Mahone; vice-president, Rezin Orr, of Fort Worth; second vice-president, Charles Thomas, of Duluth; third vice-president, J. A. Nickerson, of Milwaukee; secretary-treasurer, M. G. Moore, Detroit, secretary of the local organization; trustees, W. S. Heninger, of Toledo; E. S. Ingram, of Indianapolis, and R. K. Curtiss, of Milwaukee.

### ANDERSON OVERHEAD SPECIAL WORK.

All engineers familiar with overhead construction and electric railway operation know the value of a practical straight under running frog and crossing, to avoid the dipping and consequent sparking of the trolley wheel in passing under them, and also to avoid the tendency for the trolley to jump off at such places. The great trouble is to make a frog that will remain straight under running

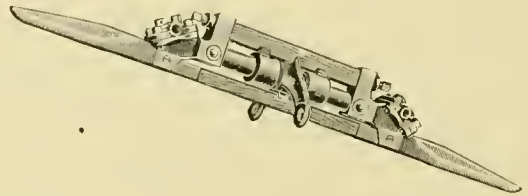

SECTION INSULATOR.

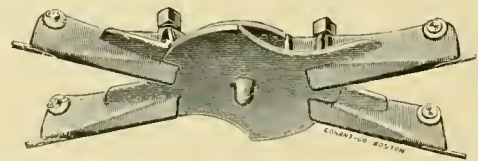
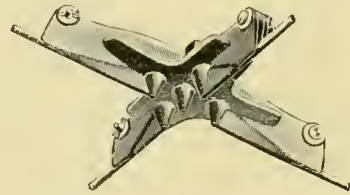

FROGS AND CROSSINGS.

when the tension of the trolley wire is put on it. A. & J. M. Anderson, of Boston, have, after experiment, devised a form of frog and crossing that it is claimed will not buckle under tension. It is not heavy and clumsy and no soldering is necessary. An electric railroad man of much experience says that they are the greatest improvement in trolley line fixtures he has noted for some time. The new section insulator is also flush under running.

THE Camden Horse Railway Company, Camden, N. J., has recently placed an order for two 350-horsepower vertical compound engines with the Ball Engine Company, Erie, Pa.

WE note with pleasure that the popular secretary of the New England Club, Francis M. Curtis, has acquired the New England agency of the celebrated Scarritt seats, of St. Louis. Mr. Curtis' office is located at 103 Milk street, Boston, and his postoffice address is box 1576. He would be very much pleased to give any information respecting these popular seats.

THE "MICHIGAN" OVERHEAD MATERIAL.

This is the name of a complete line of overhead material that has been in use on various railroads for the past two years, during which time the different devices have been subjected to the most severe test, possible, and have

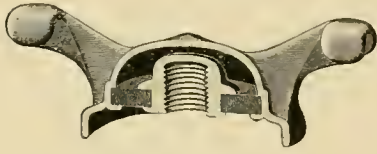

FIG. 1.



FIG. 2.

proved their merit. The devices comprising this line are all the inventions of practical men who have had years of experience in erecting and operating trolley lines, and who, consequently, thoroughly understand and appreciate the practical requirements to be met. As the span wire



FIG. 3.

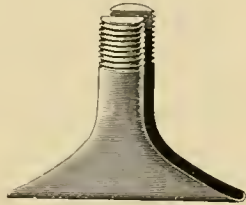

FIG. 4.

hanger is used more than any other overhead device, it is consequently the most important item of all, and the illustrations in this article are compliant to that particular device, which is shown in three sets of views; First, all apart; Second, partly assembled and third completely assembled and in place on the wire. In the first set;

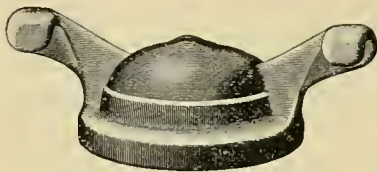

FIG. 5.

Figure 1 is a sectional view of the bell, and shows also the inside insulating washer and the nut; Figure 2 shows the outside insulating washer; Figure 3, the saddle

and Figure 4, the clamp. The inside insulating washer is held in place against the shoulder in the bell by means of lugs which are cast onto the bell and then clinched against the under side of washer, these being shown in Figure 1 as projecting inward from bell on the under side of washer. The nut shown in Figure 1 fits into a square hole in the insulating washer and is held in place by its flanged head on top and cast lugs underneath, which are also clenched against the under side of washer. In

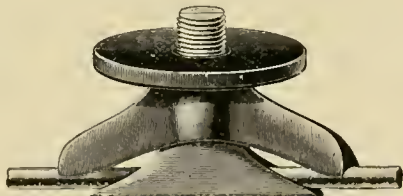

FIG. 6.

the second set of illustrations, Figure 5 shows the outside view of bell, and Figure 6 the view of clamp saddle and lower insulating washer, all in place on the trolley wire, ready for the bell to be screwed down for the purpose of

clamping the wire. As is plainly shown, the clamp is a split screw, stirrup shaped, which passes completely around the wire, and which, when the bell is screwed down on the complete clamp, draws the wire upwards in the center. As, however, the saddle holds the wire down at the outer end of the clamp, it will be seen that a slight rounding bend is thus formed in the wire and that the clamp just fills, this bend, thus preserving a perfectly straight lower side of wire and clamp, so that there is not the slightest shoulder for trolley wheels to strike against. This feature is one of the greatest importance, and not only secures a

strong grip on the trolley wire, but also results in a much longer life for trolley wheels and harps. In the third set of views, Figure 7 is a sectional view of the complete hanger in place on the

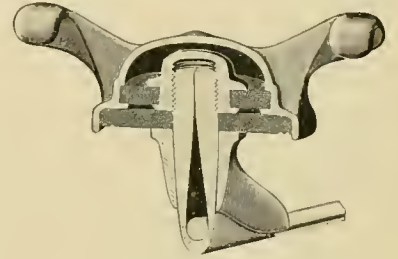

FIG. 7.

wire, and Figure 8, an outside view of same. These hangers as well as the other devices included in this line of overhead material, are made both in brass and malleable iron. This line of overhead material also includes single and double curve, barn, swinging and bracket hangers; also section insulators, splicing plates, switches cross-overs and the other devices that go to make up a complete line. All of these have been designed so as to

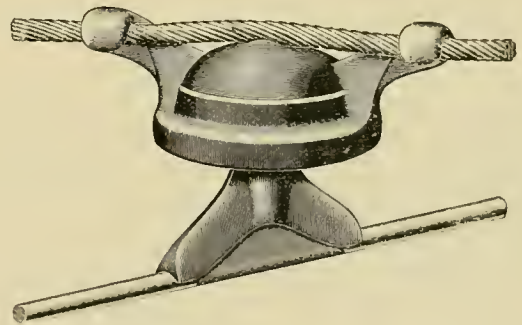

FIG. 8.

avoid shoulders and projections which trolley wheels might strike against, and also, so as to allow of their being quickly put in place on the wires without the use of any special tools. In these respects it is claimed that they are superior to any other yet designed. This line is manufactured by the Michigan Electric Company of Detroit, Mich.

THE Link-Belt Machinery Company, of Chicago, has recently sold standard water tube safety boilers to the Mutual Electric Light & Power Company, Chicago, 600-horse-power; Plainwell Church Furniture Company, Plainwell, Mich., 100-horse-power; Pittsburgh High School, Pittsburg, Pa., 250-horse-power; Institute for Feeble-minded, Pittsburg, Pa., 800-horse-power, and Detroit Chamber of Commerce, Detroit, Mich., 800-horse-power.

## A NEW CAR WHEEL.

A Whitney & Sons, of Philadelphia, are making a type of car wheel that is the most radical departure from common forms that has been introduced for some time, but the name of the makers is a guarantee that it is not without much merit. It is the invention of L. R. Faught, the mechanical engineer of the above concern. Its con-

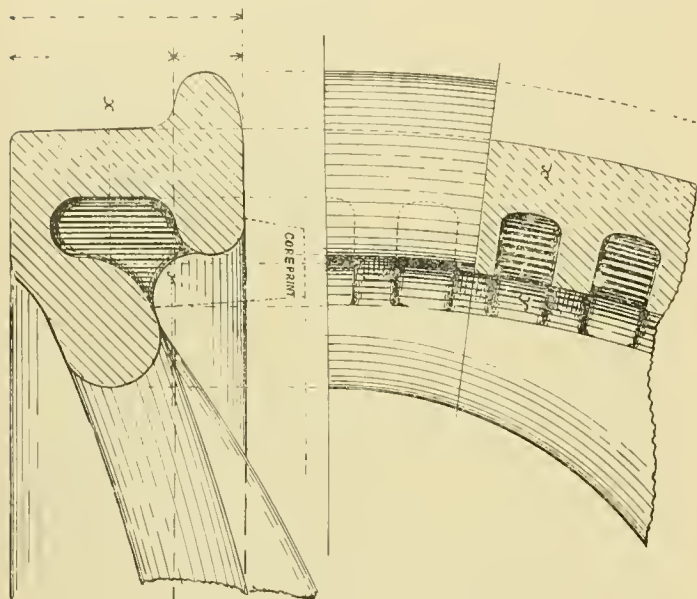

THE NEW WHITNEY CAR WHEEL.

struction will be readily seen from the illustrations. The rim is divided into a series of cavities or cells. These cells diminish the heavy body of metal usually massed in the rim but it is said does not decrease its strength. The first advantage claimed for this form of rim is that the heat of the mass of the metal in the rim and spokes is not conducted so easily to the tread when the wheel is being cast, and hence there is a better chance of getting a deep, durable, uniform chill on the tread. In casting a heavy wheel the large amount of metal in the rim communicates so much heat to the tread that there is a tendency to reduce the depth and hardness of the chill so that weight is obtained at the expense of durability, whereas, the heavier wheel ought really to have the harder tread. The second claim made for it is that the rim is more elastic under the strains and concussions of service. On the principle that small castings are more dense than large ones, the light section of the rim reduces tendencies to blow holes and shrinkage cavities

as well as giving a better chill. A further claim is made that the cellular section reduces the shrinkage strain on the wheel at time of casting and also tends to prevent crack'ng due to the heating from the use of brakes. Wheels of this form are considered stronger for the same weight than the ordinary form. The principle is applicable to all forms of cast iron and steel wheels.

## BALTIMORE FENDER ORDINANCE.

As there is so much agitation in various places in regard to car fenders, we print herewith the Baltimore ordinance. On page 639 will be found the report of the committee of the city council on fenders.

SECTION 1. Be it enacted and ordained by the mayor and city council of Baltimore. That all city passenger railway companies using any of the streets of Baltimore for the purpose of running thereon street railway cars propelled by any species of mechanical traction, shall provide for each car or train of cars, a car fender or fenders, with both front and wheel guards, of a design which the mayor, register and city commissioner shall have certified in writing over their signatures, to, in their judgment, comply with the requirements set forth in the report made to the commission appointed under the provisions of resolutions of the mayor and city council, No. 184, approved April 28, 1894, by Mendes Cohen, engineer to said commission.

SECTION 2. And be it further enacted and ordained. That a failure on the part of any of said companies to comply with the provisions of this ordinance within three months after the date of its approval, shall subject such company so in default to a fine or penalty of five dollars a day for each and every car operated without said fender or fenders, said fines to be collected as other fines and penalties for violation of city ordinances are collected.

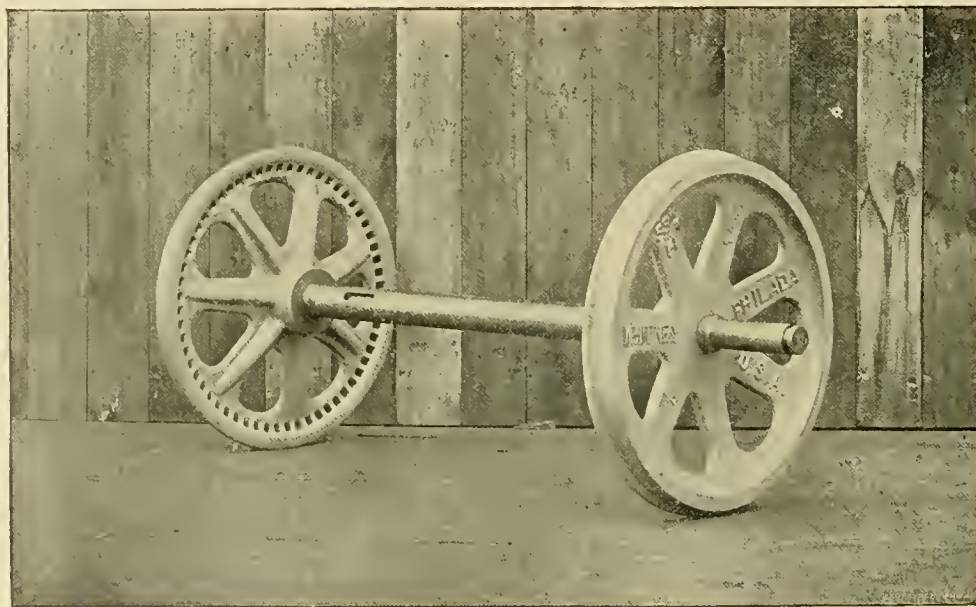

THE NEW WHITNEY CAR WHEEL.

**THE FULTON TRUCK AND FOUNDRY COMPANY.**

The Fulton Truck and Foundry Company was incorporated December 12, 1893, as a successor to the Fulton Foundry Company of Cleveland, a concern already well and favorably known to the street railway trade.



W. E. HAYCOX.

The company immediately started to build a machine and truck shop on its land at Mansfield, O. The building is brick with slate roof, 60 by 175 feet, and trucks and other street railway supplies are now being manufactured in large quantities. Interior and exterior views of the building

are presented herewith. Trucks have been or are being prepared to ship to the Passaic & Newark; Tiffin, O., Street Railway; Marion, O., Street Railway; Citizens' Electric Railway, Mansfield; Bay Cities Consolidated; Syracuse, N. Y., Street Railway; Card Electric Company, Mansfield; and Cumberland Valley Traction Company, Harrisburg, Pa.

W. E. Haycox, president and general manager, is by birth an Englishman, but came to this country in 1874, and for three years worked on a farm. He then in 1877, became a driver on an East Cleveland street car, from which he rapidly worked his way up to the position of assistant superintendent. In 1888 he left Cleveland

much to the regret of his friends, and took charge of the Utica Belt Line, which he brought up to a dividend paying basis, and later changed it to electricity. Finally Mr. Haycox refused the management of a large system to join the Fulton Foundry Company. His long experience in street railway management makes him an ideal manager for this manufacturing company.

M. B. Bushnell, vice-president, is a native of Mansfield. He was born in 1837, and received an education in the common schools with one year at Dennison University and one at Norwalk Institute. He began business life as clerk in a station on the Pennsylvania system. He rose through the positions of assistant yard master and dispatcher to that of passenger conductor and finally took the agency of the Atlantic & Great Western, at Mansfield, which position he resigned to become cashier of the Richmond National Bank of that place. During the last twenty-five years he has been an active and liberal contributor to the securing of industries to locate in Mansfield, and is a stockholder in many home enterprises.



M. B. BUSHNELL.

C. J. Langdon, secretary and treasurer, has served a longer term with the Fulton Company than the two previous gentlemen, having entered its service in 1881. He began as a telegraph operator at the age of fifteen, and for some held time a position of trust on the C. C. C. & I.

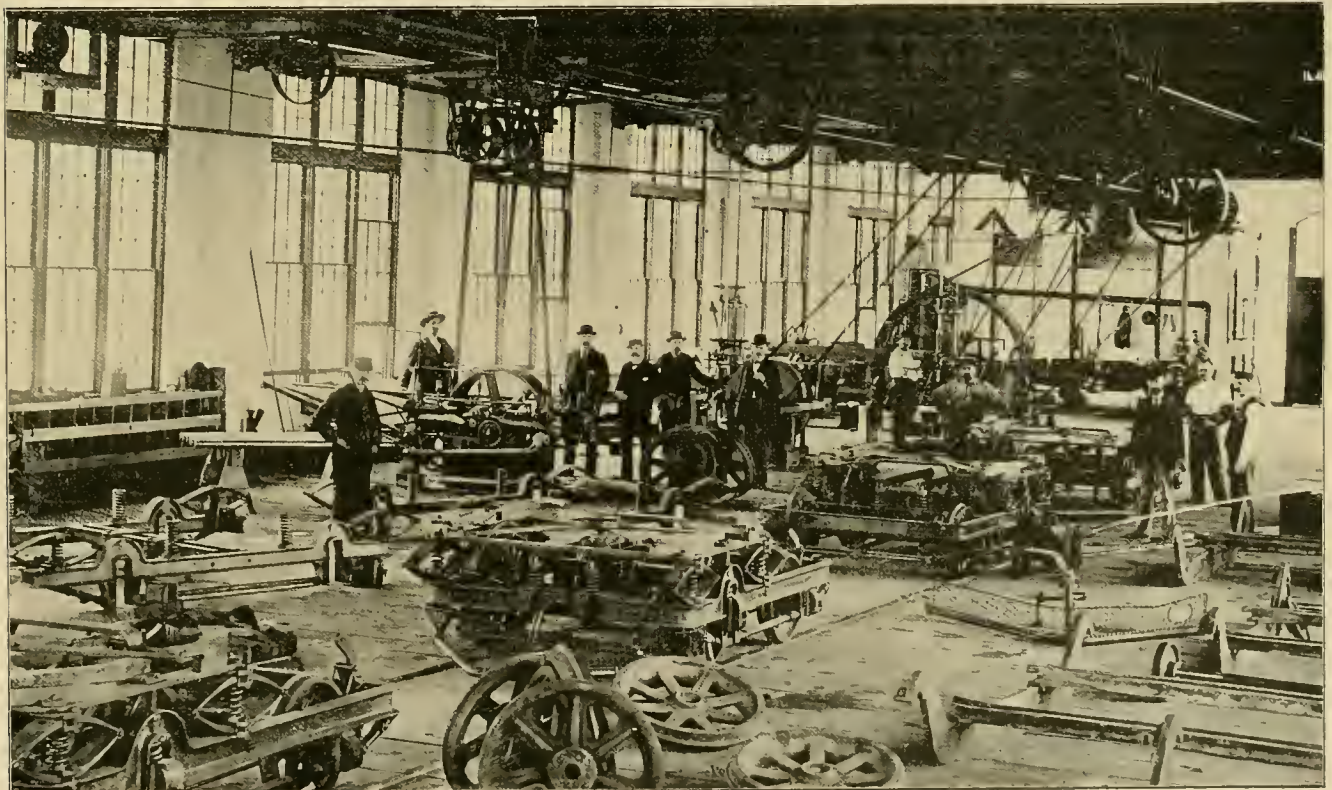

INTERIOR MACHINE SHOP—FULTON TRUCK AND FOUNDRY COMPANY.

Railroad. His executive ability has done much for the company.

Frank A. Rogers, special sales agent, accepted that position with the Fulton Truck & Foundry Company last August, after having filled a similar place with the Brush and Short Electric Companies of Cleveland, for several years. Mr. Rogers engaged with the Brush Electric Company in 1881, as foreman of the arc lamp department in the shops.



F. A. ROGERS.

In 1886 he went on the road as sales agent for the same company, and when the Short Electric Railway Company was organized in 1890, he became special sales agent for



it. It is hard to see how the sales department could be in better hands as all who know Mr. Rogers and his railway experience can testify.

The company and its officers have hundreds of friends in the railway field and those who have occasion to deal with them in the future will, as in the past, have no cause to regret it.

#### NEW YORK TO VOTE FOR RAPID TRANSIT.

New York City will vote on the question of municipal construction of a rapid transit road at the election, November 6th.

The route that has been accepted by the new commission, subject to such changes as they may consider it advisable to make, is as follows: Starting from a loop at the South Ferry, thence up Broadway with a three-track road to City Hall Park and Brooklyn Bridge, where there is to be another loop, and thence up Broadway with four tracks to Union Square, where there will be another loop, and the east side line will branch off and run up Fourth avenue to Fortieth street, and thence to Madison avenue and Forty-second street. The main line will continue up Broadway and the Boulevard with four tracks to One Hundred and Twenty-first street.

Across the Manhattan Valley from One Hundred and Twenty-first street to One Hundred and Thirty-fourth

street the road will be a viaduct, thence by tunnel to One Hundred and Fifty-sixth street, viaduct again to One Hundred and Fifty-ninth street, thence by tunnel under the Boulevard and Eleventh avenue to the King's Bridge road and to the north city line.

Above One Hundred and Ninetieth street there will be only two tracks. The road will be carried over the ship canal by a bridge fifty feet above the high-water mark. The motive power will be electricity or some other power not requiring combustion in the tunnel. The trains are to have a maximum speed of forty miles an hour.

#### NEW PUBLICATIONS.

THE Paige Iron Works is sending out an eight-page folder, giving views of special work laid down in the shop.

SIEMENS & HALSKE, of America, now have ready for distribution catalogs of multipolar and bi-polar dynamos and motors.

THE Engineering Magazine for October inaugurates a department entitled a "Review of the Industrial Press," which aims to occupy the same field with reference to industrial literature that the Review of Reviews does to the political and literary field. As it appears in the current issue it serves to give the general reader an idea of what is going on in the industrial world, but the trade press has grown to such proportions that it seems impossible to completely cover the field.

CENTRAL Station Book-Keeping, by Horatio A. Foster; W. J. Johnston Company, New York, publishers. Price \$2.50. This is, we believe, one of the first books ever published on the subject, and it is one in which there is a great field for effort. Very few electric roads or light plants have systems of keeping accounts which show the relative cost of different items. In the book are a number of forms which are the result of an examination of several hundred forms and which include the best points of all. Special attention is given to electric railway station accounts.

TELEPHONE Handbook, by Herbert Laws Webb, Electrician Publishing Company, Chicago. Price \$1. This is a little book full of useful information to all having anything to do with telephones, and companies having private lines would do well to have one in stock.

ELECTRIC Lighting Plants, by W. J. Buckley; Wm. Johnston Printing Company, Chicago. A work giving details as to the cost of installing and operating electric light plants has long been wanted and this book supplies that demand.

PRACTICAL Notes on Rope Driving is the title of a little pamphlet published by the Street Railway Journal, New York. It gives information on a subject little understood in America.

THE Western Electric Company has prepared for the trade a very complete catalogue of electric railway supplies. It includes not only everything necessary to the equipment of an electric line, but a full stock of repair parts. The new department of this company is no less complete than the older ones, and it is well known how complete that is.

MACHINERY, a low-priced, technical journal, for mechanics generally, edited by W. H. Colvin, W. H. Wakeman and Walter H. Cheney, published monthly, by the Industrial Press, New York, has reached us. The aim of the editors is to make a first-class paper, and the first number is a good one.

THE Hamilton and Lindenwald Electric Transit Company, Hamilton, Ohio, has secured a temporary injunction against McCarthy & Seegers, sewer contractors, who were using an engine for excavating purposes, which would obstruct travel.



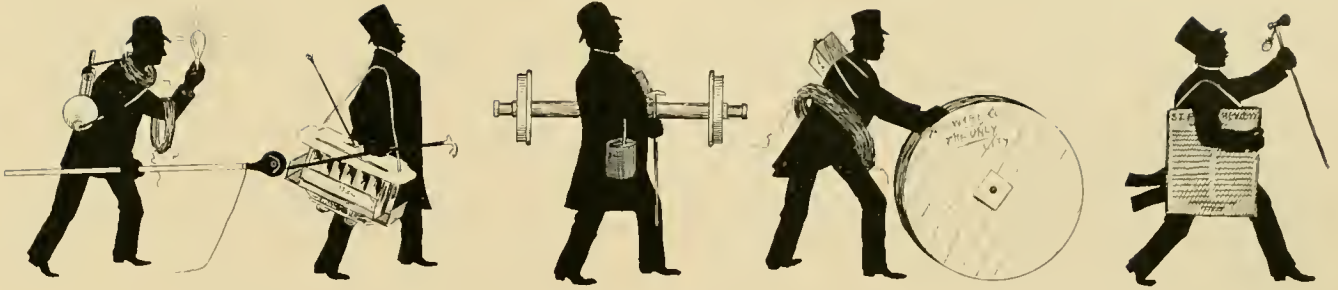

(Continued from page 596.)

The company was represented by W. F. Zimmerman, assistant general manager, of New York, W. C. Clark, general agent of Pittsburg; A. J. Wurtz, E. E., of Pittsburg; W. J. Longman, purchasing agent; B. F. Stewart, of Chicago; E. N. Heinrik, Guido Pantaleoni of St. Louis; R. S. Brown, of Boston; C. A. Bragg, of Philadelphia; D. A. Tonkin and Frank Gordon, of Charlotte, N. C.; as well as several others.

THE Brownell Car Company, St. Louis, was represented by its popular general sales agent, Wilbur B. Allen.

D. B. DEANE, of the Terre Haute Car & Manufacturing Company, circulated among the delegates and supply men.

J. H. STEDMAN, Rochester, N. Y., exhibited 42 kinds of the Stedman ticket, which has been adopted by 143 roads.

R. W. HOLLIS, Atlanta, had on exhibition an automatic motor starter and safety switch, an automatic electric elevator controller, and a combination switch and rheostat.

J. H. ALLEN, business manager of "Dixie," was among the callers on the REVIEW, as were H. M. Davis, advertising manager of Electric Power, and F. B. Vandergriff, the Car.

THE Keller Printing Company, New York, had various styles of fare, transfer and time limit tickets, under the supervision of J. F. Bushe, manager of the railroad ticket department.

THE Chicago Truck people were disappointed in getting their exhibits ready in time, but were represented by President Graham, who did good missionary work and made many friends.

THE Harris Life Guard Company, Boston, exhibited a combination centrifugal action fender and snow sweeper, consisting of revolving brooms. H. E. Harris, the inventor was in attendance.

THE Street Railway Journal was represented by James H. McGraw, C. B. Fairchild, Edward Caldwell, H. W. Pool, W. H. Taylor, R. F. Outcault, New York, and John D. Bennett, Chicago.

W. H. TAYLOR represented Pratt & Letchworth, Buffalo, but had no special exhibit. He made himself known, however, and reports good results.

GEORGE C. BAILEY, general manager of Western territory for John Roebling's Sons Company, was a constant visitor at the convention, renewing old acquaintances and making new ones.

DORNER & DUTTON, Cleveland, had their truck in operation in the Walker Manufacturing Company's exhibit, and it is described in that connection. W. A. Dutton and John Pugh were present.

S. M. BALZER New York, represented by H. J. Winsor, general manager, showed the Vernon fare register, which is an adaptation for street car use of the register on the gates of the World's Columbian Exposition, Chicago.

ARTHUR S. PARTRIDGE, St. Louis, was there with a full line of supplies. He made glad all comers with a package of blue lead pencils. His exhibit was tastefully arranged and was constantly thronged with visitors.

THE Bragg Fender Company, Troy, N. Y., represented by Dr. F. A. Bragg, general manager, had a model of its fender which bolts to the truck, and is independent of the car. There is a spring in front to protect the draw bar.

H. E. LOWE, Macon, Ga., showed a shifting switch operated by pressing a button on the front platform of a car, which makes connection on a plate in the track, moving the switch. Two plates can be used, one for right and the other for left.

THE Cutler Electrical Manufacturing Company, Philadelphia, had the new C. S. automatic cut out switch, for motors and circuits. There is no arcing when opened, and there is a protection to the fuse. Walter H. Harrington was in attendance.

THE R. C. Crawford Company, Pittsburg, showed five different styles of its celebrated fenders, both wheel guard and pick-up fenders. R. C. Crawford says he has sold 2,500 of these fenders since January 1, and showed photographs of cars equipped with the Crawford fender. He gave as souvenirs memorandum books and street car tickets.

THE New York Electrical Works, New York, showed a regular line of overhead supplies and switches, for regular and emergency work. The feature was a mechanical clutch circuit breaker, samples of which were distributed. C. W. Van Fleet was in charge.

THE John Stephenson Company made no exhibit this year, and as long as Mr. Pugh continues to attend and do the honors there is little need of cars and tracks. He distributed a pocket steel tape line, which was one of the neatest and most acceptable souvenirs.

THE Jewell Belting Company, Hartford, Conn., showed samples of its 69 inch 3 ply railway dynamo belt, bell cords and other styles of belting, and belt dressing, and distributed snake skin pocket books, one of the finest and most expensive souvenirs of the convention.

THE Chapman Valve Manufacturing Company, Boston, Chicago, and works at Indian Orchard, Springfield, Mass., showed high pressure steam valves in ten different sizes and combinations. The representatives were Edmund W. Buss, Chicago, and E. L. Ross, Springfield.

THE Hartford Woven Wire Mattress Company, Hartford, Conn., showed various styles of street car seats, and was particularly proud of an improved armless reversible seat, without foot rest, leaving an open space for cleaning cars. H. F. Evans, Western agent, was in attendance.

LEVI DEDERICK, Albany, N. Y., showed his dual street car fender, which consists of a curved fender near the track to catch bodies on the ground, and a flexible rope mesh arrangement for catching persons who may be standing. Mr. Dederick and George Poe, were showing the device.

LINBURG, SICKEL & Co., Trenton, N. J., showed a Trenton trolley wagon, which is hand made, of good material, strong and easy to handle. J. R. McCardle, who represents the company, said the wagon could be placed outside the tracks and would not interfere with the running of cars when in use.

THE W. Whitney & Sons Car Wheel Works, Philadelphia, showed a pair of 36-inch wheels for electric service, a pair of 30-inch cellular wheels, which were left with the Atlanta Consolidated, and various forms of horse car and cable car wheels. Frederick A. Lex was in attendance, and the exhibit was well arranged.

THE Wadhams Oil & Grease Company, Milwaukee, Wis., had an operative exhibit consisting of colored boys in uniform, greasing the curves of the Atlanta Consolidated Company. The badger and graphite motor lubricants and graphite for curves were shown. E. A. Wadhams, president; G. A. Streeter and A. J. Moan were in attendance.

THE Safety Clutch Brake Company, Philadelphia, had a platform fitted with two styles of brakes. One was a hand brake with ratchet at the platform, and the other had the ratchet at the handle. The work is done with the clutch at the seventh point. E. V. Faucett, vice-president and general manager, explained the device.

THE St. Louis Register Company, St. Louis, showed its security register in three styles. There was the single register, and two for double deckers connected together, and two for vestibule and double end cars. A register was shown in combination for two classes of fares, or cash and transfer. James W. Allison and Gustavus Rein were in charge.

J. H. GRAHAM & Co., New York, selling agents for the Storm Manufacturing Company, Newark, N. J., showed its sleet-cutting trolley wheel, which was fully described and illustrated in the September issue of the REVIEW. C. A. Hoagland, who was in attendance, had a great many inquiries for prices which will undoubtedly lead to some nice orders.

THE Modemann Car Fender Company, New York, showed a fender which was recently tested so satisfactorily in Brooklyn, and exhibited photographs of the test when a woman and a man were picked up uninjured. Benjamin Hendrickson, who was in attendance, was disappointed because he could not show the fender in operation on a car, as he expected.

LEONHARDT Pneumatic Safety Car Fender Company, Baltimore, showed a fender with iron frame, rope meshes, and the bottom of frame and dash protected with rubber tubes filled with air. A model of a car, with fender attached, and dolls as crew, attracted the ladies especially. William Leonhardt, president, and W. M. Ritterhouse, treasurer, explained the points.

THE New England Engineering Company, Waterbury, Conn., had a Breed emergency wagon, which is very light and strong, easy to raise and lower, one man with one hand being able to raise it in nine seconds, and if he be the driver be on top ready to work within one minute. It can be drawn with one horse. A. O. Shephardson, treasurer, was in attendance.

THE General Agency Company, New York, showed a full line of the George C. Dressel Company's electric and oil headlights and signal lights. George Dressel has been manufacturing headlights for steam railroads for thirty years. His dragon headlights are used on several street railroads in New York and vicinity. J. R. Ellicott, president, represented the General Agency Company.

THE Creaghead Engineering Company, Cincinnati, exhibited a full line of overhead line appliances and pole brackets, also photographs of work in various parts of the country. G. R. Scrugham, superintendent of construc-

tion, explained to visitors the various points of advantage in the Craghead apparatus. It is claimed that the flexible pole bracket prevents hammering, saves trolley poles, prevents arcing and is noiseless.

THE Russ Car Fender Company, Washington, had a model of a car fender which differs from all that were shown. It has been selected by the commissioners for trial on the Georgetown Railway. As soon as an object 15 pounds or heavier is struck, a spring is released, the fender opens like a gate and pushes the object off the track, and at the same time takes the trolley from the wire, and puts on brake in a half revolution of wheels.

THE Lewis & Fowler Manufacturing Company, Brooklyn, showed the improved register, which totalizes 100,000 fares. An inside and outside view was shown. F. A. Morrell and George W. Whipp, who were in charge took several orders for sweepers. The acme car jack for power houses, car houses and shop work, said to raise seven or eight tons, was exhibited. The parlor car heater with mahogany box and nickel plated trimmings was also shown.

WILLIAM T. SILVER & Co., New York, did not have an exhibit, but what was just as good, Mr. Silver saw everybody and gave to each a glass penholder and pen to remind them that he manufactured graduated coil and elliptic springs for all styles of electric cable and horse car trucks, a patent ratchet brake handle and car fender. The pen is a good one and one of them wrote nearly half of these exhibit items, and still shows no signs of wear or weakness.

JACKSON & SHARP COMPANY, Wilmington, Delaware, had a fine exhibit, consisting of one long open, new style, on four wheels; and a closed car; both running constantly between hotels and convention grounds. The open car has inclosed space at each end, for motorman, and was very tastefully decorated. The storm curtains were specially well arranged, and the car was an easy rider. President Jackson was present, assisted by George Pratt, general sales agent.

THE Young Lock Nut Company, New York, showed the Brownley injector without a valve, the Brownley brake shoe and the Young lock nut. R. D. Stewart, who was in charge, also represented the Technic Electric Works, Philadelphia, which showed the Tech rail bond and a new safety hanger for trolley lines, which provides for a break in the trolley wire by an insulated joint, which makes the fallen wire dead, so that it can be picked up without danger.

THE Barney & Smith Car Company, Dayton, O., was represented by A. M. Kittredge, superintendent, and James M. Hopkins. Two 18-foot vestibule closed cars, with plate glass windows, mounted on Barney & Smith trucks, were in operation on the local lines. One was of the pattern recently adopted by the City Railway

Company, of Dayton, a double vestibule with rear door in corner. The other was the regular standard car of the Cincinnati Street Railway Company.

THE McGuire Manufacturing Company, Chicago, showed in operation one double truck car equipped with McGuire's adjustable traction truck; also a car with Columbian AT suspension. There was on exhibition in the hall a pair of adjustable traction trucks, a Columbian car heater, and on one of the cars in operation, an air brake. W. J. Cooke, vice-president, and J. A. Hanna, were the representatives. Penwipers were distributed as souvenirs. The McGuire exhibit was very favorably received.

THE Benedict & Burnham Manufacturing Company, New York, manufacturers of pure Lake Superior copper trolley feeder and magnet wires, showed the Benedict brand of copper solid feed wire, and a patented rail bond of one piece, which, though it has only been on the market a year, has been adopted by 50 of the largest roads. It is made of any size wire, and any length, covering all sizes of fish plates. Edwin H. Oswald and J. H. Woodward, looked after the interests of the company.

SMITH, of New York, had samples of a full line of combination electric, candle and oil lamps, electric and kerosene headlights. A patent ratchet raises the wick without tearing it, and locks so that the wick does not rise on account of jolting and smoke, nor drop and go out. An electric headlight clutch was shown, which permits the lamp to be placed in any position. A three-light, 22-inch silver reflector was on exhibition, which is the largest in the world. Thomas C. Millen was in attendance.

THE Card Electric Company, Mansfield, O., showed a 35 horse power single motor operating the double imperial Fulton Truck & Foundry Company's trucks, and a double motor, for interurban roads, having large heavy cars. A new quick throw pneumatic switch, for heavy currents, was exhibited in combination with a quick throw pneumatic blow out, which throws a jet of air across the arc. The representatives were, Reid Carpenter, president; George F. Card, electrician; John F. Card, superintendent.

THE Standard Railway Supply Company, Chicago, Garson Myers, president, in attendance, showed its standard car stove as applied to car seats avoiding cutting the seat. The case containing stove is suspended directly over the seat, and is held rigidly in position there by means of fastenings at seat back and seat rail. Mr. Myers says there are 15,000 of these stoves now in use all over the country. He also exhibited the "gilt edge" steel gongs, track scrapers, adjustable track brush holders, and line material. Mr. Myers is western agent for the R. D. Nuttall Company, manufacturers of gears, pinions and trolleys.

THE Fuel Economiser Company, Matteawan, N. Y., showed specimen castings. This apparatus has been applied to a great many large power plants of electric and cable roads. Owing to the varying demands for power in these two classes of roads, the economiser is of special importance, as it holds in reserve at all times, a large volume of water at the evaporative point ready for immediate delivery to the boilers. B. Pearson, the representative of the company, says the works were kept busy even in the dull season.

THE Sterling Company, Chicago, had the only boiler exhibit, which was in charge of Thomas Deegan, secretary. A model of the Stirling water tube boiler was shown under steam and pressure. The heads of the drum were glass, enabling one to look into the interior of the boiler and note the generation of steam and circulation of water. The manner of receiving the water in the rear upper drum, the coldest part of the boiler, was seen, also the descent through the rear bank of tubes, allowing it to be brought up to steam heat before going into circulation.

THE Brooklyn Car-Wood & Veneer Works, Brooklyn, showed ceiling, plain, decorated and finished, which is made of oak veneered on poplar, and distributed wooden cards on which were shown illustrations of doors, sash, panels, etc. In connection with this exhibit was that of the Veneer Seating & Church Furniture Company, Brooklyn, showing depot seats, side seating perforated and slat, railroad car back, settee backs in veneer, and specimen advertising cards as in use on the principal lines in the vicinity of New York. W. B. Le Van, Jr., was in charge.

THE Western Telephone Construction Company had in operation a 50-telephone switch board, with various styles of telephones with magnetic transmitters. The switch board requires only a small space. There were also exhibited head 'phones with band, night alarm, six telephones of different designs, and two desk 'phones of new styles. One has a jointed arm and the other is an adjustable standing 'phone, taking only a small space and being much lighter than the long distance stand. George F. Stutch, vice-president of the company, did the honors of the occasion.

THE International Register Company, Chicago, had a working exhibit of stationary and portable fare registers. Its novelty was an aluminum stationary register in numeral form, the first ever shown. It has a satin-finish aluminum dial, which is said to be better than painted or enamel, as it always retains the same appearance. Another dial with the mechanism exposed was next to the finished specimen on the sample board, which also contained many styles of the portable registers. The mechanism in the new stationary machine is identically the same with that which has proven so satisfactory in the portable. The new aluminum stationary register was used in the Brill car No. 100. H. H. Englund, secretary and manager, represented the company.

THE Berlin Iron Bridge Company, East Berlin, Conn., had constructed a power house or car barn 20x20 with capacity for two cars. The roof was lined with the Berlin patented anti-condensation roof lining. There was also shown a section of the lining showing its construction. John M. Field, assistant engineer, who superintended the erection of the building was greatly pleased at the results of the exhibit, which attracted a great deal of attention, and secured several orders. A book of 54 pages containing testimonials from customers of the company was distributed.

THE Pennsylvania Steel Company, Steelton, Pa., showed all styles of steam and street railway work, both built and solid. The principal samples were cast steel work, switches, frogs and mates of 9-inch girder rail construction. A pyramid of rail sections from 4½-inch to 9-inch girder stood at one side of the entrance to the exhibit. There were tie plates and braces and a right angle crossing of 90 degrees, 9-inch construction. An exceedingly fine piece of work was a 9-inch groove rail curved to a radius of 6½ degrees, making a complete reverse curve. There was also shown a steam and street railroad crossing, Pennsylvania standard. The representatives were: Edmund H. Smith, treasurer; John F. Ostrom, sales agent; Charles S. Clark, Boston; Mason D. Pratt, Street Railway engineer and Charles W. Reinoehl.

THE R. D. Nuttall Company, Allegheny, Pa., showed gears, pinions, mechanical overhead work and its trolley, of which there are 10,000 to 12,000 in use. This trolley has side rods, in place of chains, with adjusting nuts on the end, with an improved double bolted socket. The foot is arranged to catch any oil that may drip. It is the lowest trolley in the market. A special feature of the exhibit was a collection of malleable iron gears, one of which had been severely hammered with a sledge, but its teeth were in splendid shape, and demonstrated that the Nuttall malleable gears can stand almost any kind of work. These gears are used by Walker, Westinghouse, General Electric, and other motors. The representatives were: President, F. A. Estep, Arthur S. Partridge, St. Louis; C. N. Wood, Boston; Charles J. Mayer, Philadelphia.

THE Hale & Kilburn Manufacturing Company, Philadelphia, was represented by its genial southern agent, B. B. Pilson, Richmond, Va., a Virginian by birth, and a handsome and cultured gentleman, who was with the Southern Railway Company for many years. He also represents in the south the Ajax Metal Company, Philadelphia; the Railroad Signal Lamp & Lantern Company, New York, and the Weir Frog Company, Cincinnati. The Hale & Kilburn Company showed rattan plush and wilton carpet seating and sample of construction. The walkover seat was its newest design, which is so arranged that a steam car can be demolished in twenty-five minutes. The back slips out and is reversible, so that both sides and back can be made new by simply turning them over.

This style of seat makes it possible to clean cars more thoroughly and keep them cleaner than where the old style of seat is used.

THE Georgia Equipment Company, Atlanta, was the only purely southern exhibit in the hall, and was tastefully decorated with cotton plants, showing boles bursted and ready to burst. J. T. Voss is president and Woodford Brooks, secretary and treasurer of the company, which handles goods of the Hubley Manufacturing Company, Lancaster, Pa.; R. Woodman Manufacturing Supply Company, Boston; Wheeler Reflector Company, Boston; Car Equipment Company, Philadelphia; Empire Electric Insulation Company, Schenectady, New York; Beacon Vacuum Pump & Electrical Company, Boston; Independent Electrical Company, Chicago; New Haven Register Company, New Haven, Conn.; R. Bliss Manufacturing Company, Patucket, R. I.; Washburn-Moen Company, Chicago; Whitney Electrical Instrument Company, Penacook, N. H.

THE Ohio Brass Company, Mansfield, O., was represented by C. K. King, manager of the railway department. The conspicuous feature was a well arranged sample board showing a full line of electric railway supplies, construction material, line devices and car material. One of the specialties was a reversible adjustable track brush holder, by which the motor man can swing off, or raise the broom from the rail as desired, there being no thumb, or set screws necessary, for it is self locking and automatic in action. Woods flexible pole bracket, the Spillman trolley car, Jewel trolley swing, a pneumatic quick "break" switch, using an air blast to blow out the arc, the Ohio trolley, simple in action and of few parts, which can be assembled or dismantled without the aid of tools. A new trolley hanger is shown in which the insulated parts are covered with metal much lighter and said to be more easily handled than many other hangers.

THE Paige Iron Works, Chicago, represented by Alonzo W. Page, president, and E. S. Nethercut, engineer, had an exhibit that attracted a great deal of attention. A section of the track was shown, illustrating Terre Haute Street Railway Construction, consisting of Illinois Steel Company 6 inch 72 pound shanghai T rail, on steel ties, and in brick pavement, to show that T rail can be perfectly used in large cities and paved streets. There was also shown a three way switch, of Illinois Steel Company's 60 pound shanghai T rail. A branch off of Illinois Steel Company's 79 pound girder rail, and a standard steam and street railway crossing, with steam railway tracks undisturbed was shown, the latter having an open throat for both lines. A portion of this work was laid on Daniel's steel ties, used by the Terre Haute Street Railway Company, and manufactured by the Daniel's Steel Tie Company, Youngstown, O. Several Wheeler suspension joints were also shown, together with photographs of work in construction on setting up floor of works.

THE following supply men were also present: Franklin E. Huntress, Boston, representing Laconia Car Company, Laconia, N. H., E. H. Allen, Allen Electric Supply and Car Equipment Company, Philadelphia; G. Frederick Collins, Valentine & Co., New York, Chicago, Boston; R. J. Mercur, New York Car Wheel works, Buffalo, N. Y., John Howard Yardly, vice-president, Philadelphia Car Wheel Co., Philadelphia; Charles E. Bibber, vice-president Cutter Electrical Manufacturing Company, Philadelphia; Charles A. Schieren, Jr., Charles A. Schieren & Co., N. Y., Edwin H. Oswald, Benedict & Burnham Manufacturing Company, N. Y., J. C. Stainwald, Chicago, representing the Standard Paint Company, N. Y., H. H. Harrison, White, Crosby Company, Buffalo; Mark D. Batchelder Company, Atlanta; Thomas A. Hurley, Holmes, Booth & Haydens, Waterbury, Conn., W. H. Taylor, Pratt & Letchworth, Buffalo, N. Y., C. A. Peterson, assistant general manager Thiel's Detective Service, St. Louis.

THE General Electric Company's exhibit was thronged all the time, and a little book was distributed, giving a catalogue of devices shown. There were GE-800 motors in machinery hall and on the lines of the Atlanta Consolidated Street Railway Company, forms "K" and "K R" controllers, switches, with the magnetic blow-out principle, fuses, lightning arresters, generator and feeder panels, total current cut-outs, underground feeding tubing, three-wire system, line material, the "Thompson '93" arc lamp, Thompson recording watt-meter and literature, describing standard apparatus for electric railway service, electric underground tubing for railroad feeders, three-wire system for electric railways, feeder panels for electric railways, supply material catalogue No. 7504, Thompson's '93 arc lamps, and Thompson's recording wattmeters. The representatives were: W. J. Clark, manager railway department, New York; A. K. Baylor, New York; J. R. Lovejoy, W. B. Potter, H. C. Wirt, G. E. Hoffman, Schenectady, N. Y.; T. P. Bailey, Chicago; H. J. Crowley, Philadelphia; F. M. Kimball, Boston; George Rosenthal, St. Louis; H. H. Corson, Nashville, Tenn.; A. F. Giles, D. R. Bullen, Atlanta office.

THE Genett Air Brake Company, New York, N. Y. had an interesting exhibit arranged by E. J. Wessels, general manager, and George S. Lee, master mechanic, showing the development of the air brake. The original air brake pump was shown, marking the commencement of air brake on surface lines; the former open style pump used with double reduction motors, now unnecessary, since single reduction motors have appeared. The enclosed double acting pump, which differs from all other pumps in this respect, as they are only single acting, was exhibited. The special feature was a combination grip and brake device, enabling the gripman to apply grip or brake separately or to work them together. There was also a collection of detail parts of the entire brake outfit and brake hose. In active operation was one heavy double truck 30-foot car on the Atlanta Consolidated

Road, equipped with the Gennett brake. This car, No. 60, is the heaviest and most difficult to run in Atlanta. Car No. 24, also equipped with Gennett brake and a testing guage, followed car No. 60, marking every compression, and a watt meter, showing the small amount of power consumption. The World's Fair award, the only one received by any company for air brakes on surface roads, was shown, together with eccentrics, guages and controlling valves.

THE Peckham Motor Truck & Wheel Company, Kingston, N. Y., New York City, Chicago and Boston, occupied considerable space with a most interesting exhibit, which attracted so many visitors that E. Peckham, president; W. H. Wilkinson, superintendent; and W. E. Cooke, manager of the Chicago office, who were constantly in attendance, were kept busy all the time. An extended and an extra long extension truck were shown. The side frames are constructed of all steel bars, so secured to the pedestals that no shearing strains come on the rivets by which they are secured. No bolts are used in the construction of the side frames, except to hold the spring pockets and wheel pieces in place. The side frames are supported upon the journal boxes by graduated spiral springs, which sustain all the weight of the car body and one-half the weight of the motors which are suspended from the side frame. The Peckham trucks were in use on some of the exhibition cars and demonstrated all that was claimed for them. The Peckham interchangeable "cushioned" motor wheels, in which all the webs are interchangeable, and a malleable iron hub pressed upon the axle by a hydraulic pressure of 35 tons to the square inch, and an elastic rubber cushion, was also shown. An elegant pocket-book for holding currency was distributed.

J. G. BRILL & Co., Philadelphia, had an exhibit that was seen before the exposition building was reached, and which was constantly in the minds of the visitors, for it took many of them to the meeting place, and brought them back to the hotels again. Three new cars were run between the hotels and the exposition grounds. One was an 18 foot on a No. 21 B truck; another was 20 feet long on double maximum traction trucks. This was an open car, and was built for the Coronado Electric Railway Company, San Diego, Cal., having been stopped in transit, and diverted to Atlanta for exhibition purposes. In the exposition building, was shown a Hall No. 21 B. truck, for single truck cars, a No. 22 maximum traction truck, truck forgings, truck frames and truck complete. There was a section of car with moveable vestibule, which can be taken off in summer and put on when desired. This section was fitted with a new device in a brake, the brake mechanism of which can be attached to the car as it stands, without moving the shaft, when the vestibule is put on the car. The open end showed the Brill track scrapers, sand boxes, life guard or fender. A full line of Brill's jacks, sample steps, and

various small devices used in the construction and operation of cars. On a single truck, in the hall, was shown a one-half elliptic spring under the boxes, a new invention. The representatives were: John A. Brill, vice-president; F. C. Randall, M. E. Curwen, George M. Haskell, Samuel M. Curwen, William H. Heulings.

THE New Haven Register Company, New Haven, Conn., had a handsome exhibit stand, showing the different styles of New Haven fare registers. The latest is a triple machine, which registers three classes of fares, 5, 10, 15 cents; 10, 20, 30 cents; or two fares and transfer. The ringing device of this register has three different sounds of bells, one for each class of fare to be registered, and consists of a specially arranged rod in combination with one cord. The number of trips is shown, together with totals for each variety of fares up to 10,000 each. The trip register can be set at zero without disturbing the total, and there is a lock, which can be set when the conductor is obliged to leave the car, so

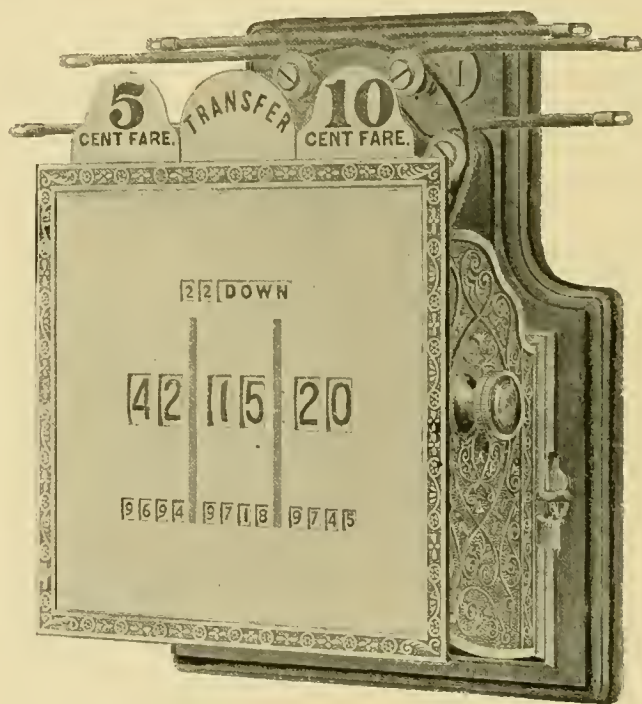

THE TRIPLE REGISTER.

that mischievous persons cannot ring up fares. A double fare register is shown, which works in the same manner as the triple machine. Single fare registers with small face, and also with the Philadelphia dial, were exhibited. The New Haven fare registers are in use on the cars of the Atlanta Consolidated Road, and attracted the favorable notice of all visitors, as well as those at the booth in the hall. Registers were shown in antique copper and bronze, bronze polished and lacquered and nickle finish. In the last eighteen months the New Haven registers have been adopted by over 160 leading street railway lines, including the Philadelphia Traction Company North Hudson County, Rochester, N. Y., Oakland Montreal, Toronto and London. The World's Fair award

was shown, and a handsome inkstand and paper weight were given as souvenirs. The representatives were: F. Coleman Boyd, vice-president and general manager, and John S. Bradley, secretary and treasurer.

THE Consolidated Traction Company of Jersey City, New Jersey, have ordered twenty Columbian trucks from the McGuire Manufacturing Company, Chicago.

WILLIAM WHARTON, JR., & CO. (Inc.), Philadelphia, was represented by Powell Evans, foundry sales agent. Sections of standard 9-inch girder rail, 90 pounds to the yard guard rail were shown, brace tie plates, chains "unbroken mainline" switches, derailing device, Columbian transfer table, and a collection of brake shoes to illustrate the paper read by D. F. Henry and Powell Evans.

THE Quaker City Car Equipment Company, Philadelphia, showed a life guard trolley brake and slack adjuster, which at all conditions of wear of shoe keeps the chain perfectly taut, and the brakeman never throws crank more than one-half or three-quarters of a revolution to put on full power of brake. J. E. Loughridge, vice-president and general manager, explained the device.

THE Walker Manufacturing Company, Cleveland, O., had about the most interesting electrical exhibit at the convention, and not only was the exhibit valuable and instructive in itself, but there were enough representatives of the company in attendance to explain everything. There was shown a 200-horse-power generator running a motor on a Dorner & Dutton truck; a complete car equipment of 30-horse-power motors: two series-parallel controllers, rheostats, cut out boxes, lightning arresters; a single motor open, showing the internal construction. Those in attendance were S. H. Short, electrical engineer; H. McL. Harding, New York; R. M. Bayliss, in charge of exhibit; B. N. Barr and James Atkinson, central office, Cleveland; Frank Kohler and G. A. E. Kohler, Chicago.

THE Johnson Company, Johnstown, Pa., had an exhibit of sections of girder rails and T rails and slot rails, for cable railways. The special feature and latest production is "guaranteed construction," which takes in frogs at crossing points and mates and switches. It consists of a cast steel box of full depth of rail, in which is set a steel plate, tempered by Prof. Harvey's process. This is the place where there is the greatest wear and least life in ordinary switch plates. A bath of hard babbitt metal and zinc is put in, holding the plates tightly in place in the cast steel box. In case of renewing any portion of the switch, it is only necessary to remove wooden pin, draw out the tempered plate, plane up and put back again. This form of construction is guaranteed for a certain per cent of the cost of work. A Du Pont truck was shown, in which it is only necessary to slacken up four bolts in order to lift car body and remove the truck from under it. The frame is of rolled steel and

the truck is of simple construction with few parts. In removing body, it is unnecessary to remove the motors, which rest on the bars all the time. After the body is removed, the wheels can be lifted over top of the truck, which is left where it is. Ernie Du Pont, the inventor, is general manager of the Louisville Street Railway, which has used the truck five years. The representatives were Daniel Coolidge, vice-president; William W. Kingston, Eugene Thomas, E. B. Entwisle, chief engineer; W. E. Boughton, Philadelphia; E. O. Evans, Boston; O. C. Evans, Cincinnati; A. S. Littlefield, Chicago; H. C. Evans, New York.

#### LESSON OF THE EXHIBITS.

Everyone acknowledged that the exhibition of appliances was the best that has been made since the American Street Railway Association has been in existence. There were 78 firms represented with tastefully arranged booths, but there were besides many supply men whose goods were of such a nature, that required no exhibition spaces, as they were specialties, or well known articles. Each was complete, but the conspicuous feature was the entire absence of anything exclusively pertaining to horse railways. The majority of the supplies were for electric



lines, which shows that the end of horse lines is rapidly approaching,

Perhaps the exhibits attracting most attention were those of the track and crossing men. The truck manufacturers were close seconds, if not on an equal basis. T rail construction was shown in various forms, there being very little girder rail shown, illustrating the fact that T rail is growing rapidly in use, and that it is only a question of a short time when the girder rail will be almost entirely superseded.

The tendency of the age as shown by truck construction and car fittings, is to economize space and to simplify parts, so that cars can be taken apart, repaired and reconstructed, if necessary, in a short space of time, without heavy expense, or moving the parts to various sections of the shops.

The line supply men had very interesting exhibits, almost each one having some new specialty. Fender men were represented in large numbers, as were the fare register manufacturers, the jingle of whose bells was incessant. Considerable interest was manifested in elec-

tric heaters, and one firm reports a sale to Rome, Ga. Other exhibitors expressed themselves as more than pleased with the result of the exhibition, as many orders were taken.

Just a word about next year's convention at Montreal. Some feeling existed on the part of the supply men, in regard to going across the border, because of difficulty, real or imagined, of getting stuff over on account of the duties. The Montreal gentlemen and the members of the committee say they are confident that everything can be arranged, so that it will be no more difficult to get goods to Canada than to any part of the United States. Goods should be consigned to the secretary of the Association, marked "samples, no commercial value, to be returned." A special custom house officer will be assigned to the exhibition place, and there will be no trouble. Definite information will be furnished later.

## TRANSFERS ON STREET RAILWAYS.

A Report to the American Street Railway Association by J. N. Beckley, President Rochester Railway Company.

The carrying of a passenger from any part of a city, reached by the lines of a street railway, to any other part of such city, reached by the lines of the same railway, for a single fare, is, speaking broadly, a new thing in street railway operation. Ten years, even five years ago, the manager who had the temerity to advise his board of directors to establish a liberal transfer system would have, probably, been regarded as unfit for his position. To-day the most successful companies have come to realize that in this matter of transfers, as well as in other matters, it pays to treat the riding public liberally.

One of the most important things to do, and to do promptly, is to educate the average man and woman to ride. That this is largely a matter of education every street railway manager knows. When a new line is opened, even through a thickly settled district, the people for some time continue to walk. Bad weather, the necessity of haste or some other thing induces a person to ride once. The next time he rides with less inducement, especially if the cars are clean, the service prompt, and if he does not have to pay more than five cents to get to his destination. So the habit grows, and soon the rule is to ride, when, before, it was the exception. A liberal transfer system, properly guarded to prevent fraud, pays. This is, I think, now generally recognized. Local conditions and arrangements of lines must be considered in determining the regulations to be adopted. The rules intended to safeguard the company are important. Perhaps equally important is the making of rules broad enough to encourage riding.

If a transfer system is adopted, it is best not to hedge it in too much by narrow restrictions or to so complicate its details as to involve labor and expend money unnecessarily. It is expedient also to appear to be making most liberal concessions to the public, especially as such concessions, presumptive or real, conduce to our own benefit. The punching "to and from," the limit of privilege to use at absolute junctions as fixed spots, different forms, and even different colors for different issuing lines, may in most cases be avoided. If we secure a proper form of ticket, we can be protected in less complicated ways, and it is usually possible with careful arrangements to cover all requirements in one form. If series and consecutive numbers be employed, we can easily trace all issues by them instead of by old methods. If we use the series and consecutive numbers, we allot a certain quantity of tickets to each conductor and follow him by them and should avoid minor details that interfere with or complicate the more important ones.

The ticket should be of liberal size to permit legible type and prevent crowded matter.

It should be bound in pads of 100, and the pad be so exactly arranged as to permit punching ten or more in one action of the punch. This feature permits canceling the month and day, and often the time, ten or more at once and accurately, and frequently several of the same destination. It is of great advantage to secure full "month," "days" and "time" space on each ticket, that can be accurately and quickly punched,

and it forestalls the waste, expense and detail consequent upon daily dated tickets, while it gives equal protection without delay anywhere.

The subject matter ingeniously arranged can and should comprehend in one form all needed rules. "Good for this current trip—at point of change—on next car after time canceled—to destination punched," illustrates this. "Subject to rules of company," covers several dozen words of the old form with equal rigidity. Special conditions may vary this, but in most cases it is restriction enough.

"A series number"—"conductor's number"—"run" of "car" number, or some such designation on each ticket, will identify the issuer perfectly, and the consecutive number will trace the issue, hold it to sequence in use, and prevent tampering and fraud. We have some 200 conductors. Each has a stock of 25,000 tickets to begin with, renewed as used. Our transfer department has 250 compartments on the wall of the room to hold these tickets (thus providing for increase in conductors) each of 25,000 capacity, so they are all systematically arranged in simple order, one compartment for the tickets of each conductor. The conductor turns in his unused transfers at the end of the day's work, and they are put in his compartment, and given out to him on beginning work next day. A simple record book keeps this account; one double page for each conductor covers his transactions for the whole year, and shows at a glance each individual transfer account, for comparison or aggregating statistics.

Forenoon and afternoon are distinguished by light and black print in the destination blocks, and by the system we use we get month and day, one punching each (but always preliminary, the conductor keeping these punched ahead in readiness), and one punch for time (even hour or ten minute interval) and one for destination. I need not explain that such a ticket supplants the expensive duplex form—for it is equally protective—nor enter upon any argument in favor of the absolute need of a short time limit. The day limit, a. m. or p. m. limit, or even the hour limit, is of a by-gone day, too leaky to be considered, and very few companies now use it.

It is important, in my judgment, to arrange the form clearly, each section; name, rules, time, days, months, destination, series and consecutive number, to have a distinctive and spacious position and be clearly defined by itself, not scattered about. It is also very important, in order to foster accuracy with rapidity, to so far arrange the reading matter that the ticket shall be punched and read as punched, all one way, being held by thumb and finger of the left hand and punched with the right. Inverting and twisting the ticket not only takes time, delaying traffic, but increases inaccuracy. The ticket should be arranged in every detail so as to be within the mental grasp of the average conductor, and so as to make it easier for him to go right than to go wrong, easier to be quick than compelled to be slow. Regular horizontal and vertical lines soon fix themselves on the dullest intellect, but scattered details, hopping about a ticket, often puzzle the brighter ones.

In order that all punching may be done before tearing off the ticket from the stub, and that all possible advantage of the pad form and multiple punching can be secured, all sections to be punched should be arranged on the lower side and right hand end if possible.

The pad form saves counting the 100s, while the consecutive number counts the broken pads. The pad form is most convenient in handling in the office or on the cars, and saves time wherever used in giving out, in issuing or receiving or in taking stock. The use of the months is not important. If there be room for them there is no objection, as with the pad form they are no obstacle to quick service, as they can be punched in advance of use. Many companies omit them, as the other restrictions practically give little opportunity for fraudulent use after thirty days. By beginning the consecutive number of each pad at 0, 100, 200, etc., we save complication in subtracting, as then the consecutive number on the upper remaining ticket instantly shows how many tickets have been removed.

The consecutive number is not only useful in counting, but compels proper use of the tickets. In conjunction with the time table, each ticket must show when turned in that it was issued in sequence of number and in sequence of time. No. 6,230, say, is issued at 9:30 A. M. Nos. 6,231 and 6,232 may not be returned at all, but if they are, they must show issue in direct sequence of time. If not so, the series number tells us instantly who issued the ticket, and the man is spotted and the wrong exposed, for tickets cannot be abstracted and punched for future use as they will not fall within proper time limit, and in proper sequence. We make conductors note on the daily car report the consecutive number of the transfer with which the day's work begins and the consecutive number with which it ends. At the close of each trip each conductor turns in the transfers taken in on such trip in a special trip envelope, dropping them in a box prepared for that peculiar purpose.



This box is placed at our grand junction, which all cars pass, but a number of such boxes could be used where different conditions obtain. We know at once who wrongly issued a transfer, who received it and when it was done. A notice in our cars requires the passenger to ask for a transfer when fare is paid. This rule enables the conductor to issue transfers at his convenience, and distributes the labor of so doing instead of massing it at certain junctions, with confusion and delay.

Nor is it necessary to resort to tickets on a roll or in metal clasps or such device for protection. The roll method necessitates single issues, singly punched, and loses the advantage of multiple punching, while it delays traffic and increases chances of error. The metal bound tickets add expense, but do not increase protection. Tickets may be just as easily abstracted in advance of proper use as in the pad form—so they may in the roll, for that matter. Real protection lies only in the system, not in the binding. Conductors cannot sell, trade or exchange transfers with series, consecutive numbers and time table without detection, and if the transfers be turned in on every trip, detection is a very simple process, requiring no elaborate and costly inspection.

A special register for transfers, and so eliminating their cash value, does not help us. It confuses the conductor and paralyzes the spotter, and without a protected form of ticket, conductors can collect fares and ring them up on the register, and turn in each other's transfers to balance the account.

By putting the transfer business into the hands of the conductors, we cater to the convenience of passengers, and we obviate delays in traffic, consequent upon stopping cars to transfer. We save the large expense of transfer agents, and, in my judgment, do not increase leakage, for it is as easy for transfer agents to stand in with conductors to defraud the company, as it is for conductors to combine with each other. The numerous and continual frauds perpetrated upon transfer agents, by people who get transfers without having paid any fare, is too well understood to require discussion.

We have adopted a system of "faces identification" for moral effect, and especially for use at the noon hour, when abuse in transfers is most frequent. As soon as we have converted our stock of tickets to the new form, we shall put them into effect. They are, I understand, now in use in Minneapolis, St. Paul, New Haven, Binghamton and Scranton.

In conclusion, I need only add that our liberal system of transfer has proved a good investment, and that our form of ticket is efficient and protective. Simple, convenient and safe, yet systematic, distinct and business-like, it protects our interests, while it saves us all former waste and a vast amount of useless labor.

#### SATURDAY AT CHATTANOOGA.

No better day could have been made for seeing Lookout Mountain and Missionary Ridge, than Saturday, when bright and early the New York, Boston and Chicago parties found cars waiting to take them to Lookout Mountain. They were guests of the Chattanooga Electric Railway Company, S. W. Devine receiver, and Warner S. McCall, general superintendent; Capt. H. S. Chamberlain, president of the Union Railway Company, and the Chattanooga Chamber of Commerce. The climb of the mountain was made by the standard gauge road, which landed them at the inn. Point Lookout and other places of note were visited. Henry C. Payne, ex-president of the association, was invaluable, as his graphic descriptions of the battles, and the positions of the troops, made everybody realize as nearly as possible at this late day, what really occurred. Senator Willard Warner, who has lived at Chattanooga since the war, and was a member of General Sherman's staff, was present at all the battles, and gave an interesting talk.

Luncheon was served at the inn, and a ride was taken in the narrow gage to the upper terminus of the incline. This is directly above the site of the "Battle in the Clouds." By means of the incline, the mountain was descended. Cars were taken to Missionary Ridge where

Mr. Payne and Senator Warner again described the battles. The National Cemetery was visited, where 13,000 soldiers lie buried, many of them known by number only, the names having never been discovered. The fighting occurred in November, so that a splendid idea was obtained of the situation, except that only when the cemetery was visited, did the visitors begin to realize and only in a small degree, the awful and terrible sight that must have been seen from those beautiful heights the day after the battle.

In the evening, at the suggestion of H. P. Bradford, general manager of the Cincinnati Inclined Plane Railway Company, the Chicago, Boston and New York parties that attended the Atlanta convention, who visited Chattanooga on the invitation of the Chattanooga Company, and were treated so handsomely, met in the railroad depot to appoint a committee to draft resolutions expressing their gratitude at the handsome entertainment that had been provided for them. Col. J. H. Cunningham, president of the Massachusetts Street Railway Association, and one of the new vice-presidents of the American Street Railway Association presided. The following committee was appointed: H. O. Nourse, of the Scarritt Car Seating Company, St. Louis and Chicago, James W. Nagle of "The Car," H. J. Kenfield, of the STREET RAILWAY REVIEW; John D. Bennett of the Street Railway Journal, M. J. Sullivan, Electrical World; Charles Pierce, Electrical Review; T. C. Martin, Electrical Engineer and W. F. Collins, Western Electrician. After these resolutions are prepared they will be given to the various journals represented at the convention for publication.

#### SUNDAY AT CINCINNATI.

The Chicago contingent was pleasantly entertained at Cincinnati. John Harris, general superintendent of the Cincinnati Street Railway Company, and Bayard Kilgour took a party in a carriage ride to the various power stations of the company, and through the fine residence sections. The company is building a new power house on Depot street. This station will be equipped with 10 General Electric, 600 Kilowatt generators, working in pairs, direct connected to 5 McIntosh & Seymour tandem compound engines of 2,300 horse-power each, connections being made by means of a clutch coupling. Seven Abendroth & Root Manufacturing Company's boilers of 500 horse-power each, arranged in pairs, are being put in, fitted with Roney automatic stokers. The boilers are arranged for artificial draft, the apparatus being furnished by Westinghouse, Church, Kerr & Co. The power generated in the Brighton station is 2,170 kilowatts; East End, 1,306 kilowatts; Hunt street, 1,726; total 5,202 kilowatts. The new Depot street and Cummingville stations, the first having 12 multipolar 300 and the second 10 multipolar 300, and the direct connected 800 to be installed in the Brighton station, brings the total to 12,602 Kilowatts. The motor equipment now in use consists of 277 motors, being 28 F. 40; 35 S. R. G., 30; 50 W. P. 50; 14 Westinghouse; 20 Sperry 10 h. p.; 150 G.

E. 800. Orders for additional equipments have been given for 85 G. E. 800; 35 G. E. 1,200; bringing the total equipment up to 397 motors. With the exception of a very few miles, all overhead construction is of double trolley. Current is now being carried a maximum distance of 6 miles. The extensions now being built will, when finished, terminate 15 miles from the power house. On one of these long lines the multiphase system will be installed. Its results will be watched with a great deal of interest, as it will be the first installed in this country.

The gentlemen who were entertained were: J. M. Atkinson and D. M. Barr, the Walker Manufacturing Company, Cleveland; W. E. Haycox, F. A. Rogers, the Fulton Truck & Foundry Company, Mansfield, O.; Joseph E. Lockwood, Michigan Electric Company, Detroit; George W. Baumhoff, general superintendent Taylor Avenue Railway Company, St. Louis; John Harris, Bayard Kilgour and two members of the REVIEW staff.

### CONVENTION NOTES.

One of the most delightful entertainments of the convention was furnished to the REVIEW party at Chattanooga, Tuesday evening. Superintendent Warner S. McCall, general superintendent of the Chattanooga Electric Railway Company, had a private car in waiting to take the Chicago party to Lookout Mountain. It was a beautiful ride in the moonlight, the air was soft and balmy, but on the heights 1,700 feet above the city it was quite cold. It was a sight that will never be forgotten. Mr. McCall received the grateful thanks of all the fortunate



THE REVIEW'S CHATTANOOGA ORCHESTRA.

participants in his hospitality, which was all the more appreciated because of its informality. Some of the party discovered three darkies, one with a guitar, one with a banjo, and one with a piece of two-inch gas pipe, two and a-half feet long. A concert was given by these players, which was very greatly enjoyed, as much on account of its novelty as anything else. The gas pipe fellow used a coupling for a mouthpiece, and played a bass accompaniment that sounded like a slide trombone. His cheeks puffed way out, and the tears gushed from his eyes, he blew so hard. The party consisted of: Mr.

and Mrs. W. S. Dimmock, general superintendent, Omaha & Council Bluffs Railway & Bridge Company, Council Bluffs, Ia.; Mr. and Mrs. A. M. Turner, secretary and treasurer, Hammond Electric Street Railway Company, Hammond, Ind.; Mr. and Mrs. Edwin A. Smith, Consolidated Car Heating Company, Chicago; Mr. and Mrs. M. J. Sullivan, Electrical World Chicago; Mr. and Mrs. H. H. Windsor, STREET RAILWAY REVIEW, Chicago; J. W. Meaker, Meaker Manufacturing Company, Chicago; Alonzo W. Paige, Paige Iron Works, Chicago; George F. Stitch, vice-president Western Telephone Construction Company, Chicago; Max A. Berg, secretary, Wallace Electric Company, Chicago; James Partridge, Partridge Carbon Company, Sandusky, O.; W. F. Collins, Western Electrician, Chicago; W. H. Taylor, Pratt & Letchworth, Buffalo; H. J. Somerset, Winnipeg Electric Railway, Winnipeg, Can.; John D. Bennett, Street Railway Journal; A. Hoffman, Milwaukee; Mr. and Mrs. T. H. McLean, Indianapolis; Elmer A. Sperry, Cleveland.

Friday afternoon several ladies and gentlemen rode out to the cotton fields at Decatur. On the return the motorman just to show them what he could do gave them the fastest time they had ever ridden on an electric line. He started at the top of a hill with 13 per cent grade about a mile long and put on all the current. Old steam railroad men said that the speed was not less than 60 miles an hour, and at the bottom was a curve which was ridden in safety.

COULD weather have been finer ?

C. E. STUMP, was in attendance looking after the interest of the Street Railway Gazette.

McNAMARA BROS., Fairhaven, Vt., who deal in slate for switch boards distributed a paper weight.

W. W. KINGSTON and Joel Hurt of the local committee, covered themselves with glory in their successful efforts to keep the ball rolling.

THE Duff Manufacturing Company, Allegheny, Pa., distributed glass paper weights, advertising the Barrett patent compound lever, track and oil well jacks.

THURSDAY afternoon the delegates took special cars and were taken about the city, going to the top of the Equitable building, and visiting the capitol and a cotton press.

PRESIDENT PAYNE's party came in a special car and included Mrs. Payne; her niece, Miss Margaret Jones; General Manager C. D. Wyman and Charles L. Jones, purchasing agent.

S. J. WICK ably represented his company, the Electric Railway Equipment Company, of Cincinnati, and threw light along the path of all seekers after the truth of the long line of this company's supplies.

THE plan to extend the convention hereafter to four days will be appreciated by all. The work has now assumed such magnitude that three days are as inadequate as formerly they were too long.

JAMES PARTRIDGE represented the Partridge Carbon Company, Sandusky, O. Although he had no space in the hall, he became acquainted with many people who use his carbons, and reports several orders.

STREET railway men who did not receive the little souvenir, "Coons in the hole," may have one mailed to them by addressing the Scarritt Car Seat Company, St. Louis, Mo., or H. O. Nourse, 941, Rookery, Chicago.

THE trip through Kentucky, Tennessee and Georgia was a revelation to northern guests. Nature seemed to have decked herself in Sunday raiment, and from Cincinnati to Atlanta the valleys and mountains shone in one prolonged blaze of glory.

EDWARD BEADLE who never misses a convention but whose absence would have been a regret to lots of people, was present though making no exhibit of the Railway Register Manufacturing Company. In fact, there is little need to do so, so well known are these excellent machines.

BOTH the Aragon and Kimball houses did themselves proud in service, menu, and general comfort of guests. At no city have the delegates been better cared for and in some not nearly as well. The visitors carry away very pleasant recollections, and many will return this winter for a longer stay.

MORRIS, TASKER & CO., Philadelphia, have been made sole manufacturers of the Duggan Patent adjustable Pipe Bracket, considered by many managers the best, cheapest and simplest on the market. The price has lately been greatly reduced, and they can be purchased direct from the manufacturers, or from the Burnham & Duggan Railway Appliance Company of Boston.

THE advantages of having the "whole show under one roof" was appreciated, but another year it would be well in assigning exhibit spaces to locate such displays as make no noise nearest the convention hall; for instance, track, overhead, or lamp supplies, instead of motors and fare registers both of which latter must necessarily make considerable racket if illustrating the operation of their machines, and that is what they come for. There really is no need of placing the noisy exhibits so near the session room, as there are always plenty of silent displays.

JOHN PUGH, he of small frame, but big heart, has accepted the general eastern agency for those successful manufacturers of street railway trucks, track cleaners, wheels, gears, etc., Dorner & Dutton, of Cleveland. Mr. Pugh is an old settler—for a young man—in the street

railway supply business, having served in the several departments in the John Stephenson Company, in 1871, and has been connected with the street railway trade ever since. His acquaintance is equalled by but few, and his popularity is fully equal to its extent. His friends gladly congratulate both Mr. Pugh and his company on this new connection and wish him continued and ever increasing success.

#### A BRILLIANT BANQUET

The great social feature of conventions has always centered in the annual banquet, and the years as they have gathered in number have maintained a commendable opinion of pleasant rivalry, which has aimed on making each dinner as good or better than its predecessors. Hence it is no small undertaking in any city, to provide a menu and speakers, which shall attain to the high standard so long established.

Atlanta, however, was fully equal to the emergency, and the table, the service, and entire management of the occasion was all the heart could wish. The feast was spread in the spacious dining room of the Kimball house, which was profusely decorated with hundreds of flags, flowers and potted plants. Promptly at nine o'clock four hundred of the "400" were seated, and the dining commenced.

After the feasting, President Payne called on J. H. Stedman, of Rochester, who responded in verse. The next speaker was Howard E. W. Palmer, of Atlanta, whose toast "Atlanta" awakened great applause.

C. Densmore Wyman, of Milwaukee, whose after dinner speeches are always excellent, followed with "Our Association," and surely no more appropriate selection could have been made than in the assignment of this toast.

"The Street Car as a Factor of Civilization" was responded to by Lewis Perrine, of Trenton, who traced the evolution of the street car.

Capt. Harry Jackson, spoke on "The Railroads and the Law," and closed with an eloquent tribute to the unseen element.

"The New South" was portrayed by Hon. Lionel C. Levy, of Columbus, who showed how the race problem was working out its own solution, and concluded with an enthusiastic prophecy of the future.

"The Technical Press" was responded to by J. H. McGraw, of the Street Railway Journal, who set forth the good work of the trade journal. He was frequently applauded.

The speech of the evening was made by a newspaper man, Lucien L. Knight, of Atlanta, who responded to "the Local Press" from whose remarks the following is an extract:

"If you will excuse the platitude we live in the brightest era of the world's development—an era that has witnessed the sublimest miracle since man became a living soul; for electricity on every hand is writing the peroration of the century. The pressure of a button now starts a factory into motion and causes a myriad flame to leap into a carnival of light. A single wire, stretched along the highway, carries from city to city the message of the human voice and guides the progress of the locomotive dashing along as if in the exercise of its own volition. Oceans

have been wiped away and continents united until Europe lies across the common, and Asia is beyond the forests that guards the frontier of the neighborhood. Science has illuminated the night with her soft witchery and pilfered the eternal birthright of the stars. Like the moping owl, the moon has herself lodged complaint against the trespasser that seeks to "molest her ancient solitary reign." \* \* \* \*

"In conclusion, sir, my interpretation of this banquet and this splendid gathering is this: That Georgia stands shoulder to shoulder with New England; that we of the south allied with you under the banner of progress are as ready to cope with you in peace as we have already vied with you in war; that we are ready to strike hands with you in fraternal combat, and to struggle with you in thrif as we have in chivalry. Though we may differ in politics we are one patriotism; though we may scatter with the increase of our children we are one in the blood of our fathers, differing as in the blooms that wrap your northern hills as in the flowers that deck our southern fields, but in love and destiny and high resolve forever mingling like the common stars that charm the vision of the stilly night as they drift to the breaking of the day."

"Our Country" appropriately closed the program, and F. G. du Bignon, of Atlanta, was called on to reply, being frequently interrupted by loud applause. President Payne then proposed the health of Mr. Hurt, the president elect, which brought the evening to a close, and as the banqueters dispersed were surprised to find it 2 o'clock Friday morning.

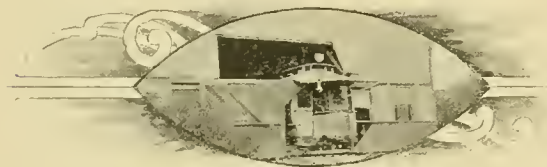

#### LIST OF STREET RAILWAY MEN.

Akamann, J. N., Worcester, Mass.  
 Allen, J. P., St. Louis.  
 Adams, J. T., Atlanta.  
 Atken, J. W., Carbondale, Pa.  
 Adkin, J., St. Louis.  
 Baker, R. F., Washington, D. C.  
 Barnes, C. E., Plymouth, Mass.  
 Bailey, T. P., Kalamazoo, Mich.  
 Belden, D. A., Aurora, Ill.  
 Burg, E. H., Harrisburg, Pa.  
 Brown, N. W. L., Atlanta.  
 Bradford, H. B., Cincinnati.  
 Brown, O. B., Cincinnati.  
 Breed, E. S., New Britain, Conn.  
 Bridges, F., Dayton, O.  
 Baumhott, J. W., St. Louis.  
 Bull, J. V., Easton, Pa.  
 Bartlett, C. H., Manchester, N. H.  
 Bickford, J. H., Manchester, N. H.  
 Burk, M. F., Terre Haute, Ind.  
 Brang, C. A., Phillipsburg, Pa.  
 Carpenter, Reid, Mansfield, O.  
 Cameron, W. H., Milwaukee, Wis.  
 Cougot, P., New Orleans.  
 Clark, C. S., Lawrence, Mass.  
 Cunningham, G. C., Montreal, Can.  
 Chidsey, A. W., Easton, Pa.  
 Connette, E. G., Nashville, Tenn.  
 Corson, H. H., Nashville, Tenn.  
 Coolihan, E. L., Montgomery, Ala.  
 Cole, W. W., Elmira, N. Y.  
 Crossman, T. C., Official Stenographer,  
 New York.  
 Crowley, H. J., Shamokin, Pa.  
 Cunningham, J. W., Haverhill, Mass.  
 Dunlop, G. F., Washington, D. C.  
 Davis, E. H., Williamsport, Pa.  
 Dyer, D. B., Augusta, Ga.  
 Duncan, D. J., Carbondale, Pa.  
 Davis, S. C., Piqua, O.  
 Dyer, P. M., Chicago.  
 Dodge, E. A. W., New Haven, Conn.  
 Dimmock, W. S., Omaha, Neb.  
 End, W. G., Wilkes-Barre, Pa.  
 Elkins, W. L., Pittsburg, Pa.  
 Evans, D. E., Gainesville, Ga.  
 Edgo, H. D., Atlanta.

Knight, F. S., Easton, Pa.  
 Krotz, A. S., Springfield, O.  
 Landon, E. T., New York City  
 Linburg, W. H., Brooklyn, N. Y.  
 Lodge, Geo., Philadelphia.  
 Lord, D. J., Boston.  
 Leen, P., Cincinnati.  
 Larendon, W. S., Atlanta.  
 Moore, G. C., Taunton, Mass.  
 Meixell, J. C., Wilkes-Barre, Pa.  
 McKinley, W. B., Springfield, O.  
 McCreedy, J., Albany, N. Y.  
 McNamara, J. W., Albany, N. Y.  
 McCreary, J. B., Atlanta.  
 McClary, J. B., Birmingham, Ala.  
 Musser, F. B., Harrisburg, Pa.  
 Markle, A., Hazelton, Pa.  
 McKinney, C. A., Houston, Tex.  
 Minary, T. J., Louisville, Ky.  
 McAllister, Henry, Camden, N. J.  
 Morgan, J. W., Camden, N. J.  
 McRedie, J., Covington, Ky.  
 Marshall, J. Q., Columbia, S. C.  
 Morehead, H. B., Cincinnati.  
 McCulloch, Robt., St. Louis.  
 McCulloch, Richard, St. Louis.  
 Miley, C. E., Springfield, O.  
 McCreedle, J., Cincinnati.  
 McLaughlin, J. F., Philadelphia.  
 Mahoney, Dan, St. Louis, Mo.  
 McFarland, J. W., Savannah, Ga.  
 Nelson, S. L., Springfield, O.  
 Noble, W. P., Cincinnati.  
 Orr, A. M., Piqua, O.  
 Payne, H. C., Milwaukee, Wis.  
 Pratt, C. B., Worcester, Mass.  
 Park, J. G., Washington, D. C.  
 Pratt, E. J., Webb City, Mo.  
 Patterson, W. H., Bloomington, Ill.  
 Partridge, J. S., Brooklyn, N. Y.  
 Palmer, H. E., Atlanta.  
 Passalaigne, T. W., Charleston, S. C.  
 Pond, A. E., New Haven, Conn.  
 Pennington, T. C., Chicago.  
 Pierson, C. H., St. Louis.  
 Pratt, M. D., Steelton, Pa.  
 Richardson, W. J., Brooklyn, N. Y.

Ewing, F. W., Nashville, Tenn.  
 Ewing, A. B., St. Louis, Mo.  
 Ehrman, F. J., Philadelphia, Pa.  
 Faulk, C. J., Worcester, Mass.  
 Pugin, J., Wilkes-Barre, Pa.  
 Flisk, L. N., Piqua, O.  
 Flynn, C. E., Peoria, Ill.  
 Ferguson, W. L., Decatur, Ill.  
 Ferguson, W. G., Worcester, Mass.  
 Ford, D. J., Gloucester, Mass.  
 Gillee, O. C., Washington, D. C.  
 Graham, J., Wilkes-Barre, Pa.  
 Glenn, W. K., Atlanta, Ga.  
 Green, A., Rochester, N. Y.  
 Goff, R. S., Fall River, Mass.  
 Green, Chas., St. Louis, Mo.  
 Garth, R. L., Chicago.  
 Glenn, W. H., Atlanta.  
 Glasier, A. F., Brockton, Mass.  
 Griffin, J. B., Hamilton, Ont.  
 Goodrich, E. S., Hartford, Conn.  
 Hollenback, J. W., Wilkes-Barre, Pa.  
 Hurt, Joel, Atlanta.  
 Hunt, Dr. C. D., Atlanta.  
 Henry, W. L., Brockton, Mass.  
 Hendrickson, B. F., Bay City, Mich.  
 Herty, T. H., Macon, Ga.  
 Hayden, D. C., Milwaukee, Wis.  
 Hank, C. A. B., Hazelton, Pa.  
 Harrington, W. E., Camden, N. J.  
 Helle, G. W., Utica, N. Y.  
 Howard, W., Youngstown, O.  
 Heyward, J. F., Baltimore.  
 Hunter, R. S., Springfield, O.  
 Hood, W. S., Springfield, O.  
 Hunter, F. W., Nashville, Tenn.  
 Harris, E., Birmingham, Ala.  
 Harrison, Russell B., Terre Haute, Ind.  
 Hamilton, G. D., St. Louis.  
 Hippec, Geo. B., Des Moines, Ia.  
 Jenkins, T. W., Covington, Ky.  
 Jenkins, T. W., Cincinnati.  
 Jewell, W. S., Toledo, O.  
 Jackson, Henry, Atlanta.  
 Jones, J. G., Memphis, Tenn.  
 Jones, C. L., Milwaukee, Wis.  
 Johnson, G. S., Grand Rapids, Mich.  
 Johs, J. W., Kalamazoo, Mich.  
 Kobusch, G. J., Kalamazoo, Mich.  
 Koche, J., Cleveland.

Reed, W. P., Salt Lake City.  
 Rugg, J. E., Pittsburg.  
 Rink, H., Easton, Pa.  
 Rodenburg, J. S., Easton, Pa.  
 Richards, E. J., Lexington, Ky.  
 Rhea, R. M., Knoxville, Tenn.  
 Rice, Faunt, Atlanta.  
 Rush, C. O., Bay City, Mich.  
 Seibell, G. F., Taunton, Mass.  
 Smith, C. H., Troy, N. Y.  
 Somerset, H. J., Winnipeg, Man.  
 Sloan, Frank H., Baltimore.  
 Stratton, J. A., Birmingham, Ala.  
 Scott, R. F., Montgomery, Ala.  
 Smith, W. A., Omaha, Neb.  
 Smith, W. Nelson, New Orleans, La.  
 Sinclair, W. H., Galveston, Tex.  
 Sergeant, C. S., Boston.  
 Shaffel, W. H., Asbury Park, N. J.  
 Sullivan, P. F., Lowell, Mass.  
 Stone, E. K., Quincy, Ill.  
 Smith, J. A., Cincinnati.  
 Stevens, E. H., Johnson City, Tenn.  
 Shaw, E. P., Haverhill, Mass.  
 Smith, B. G., LaCrosse, Wis.  
 Sidden, W. L., Atlanta.  
 Semmes, R., Mobile, Ala.  
 Tyson, L. D., Knoxville, Tenn.  
 Tullie, A. C., New York City.  
 Thompson, S. B., Baltimore.  
 Thompson, A. C., St. Louis, Mo.  
 Titus, A. C., Newport, R. I.  
 Urie, T. K., Galveston, Tex.  
 Vail, J. H., Poughkeepsie, N. Y.  
 Wight, L., Toledo, O.  
 Woodruff, R., Trenton, N. J.  
 Woodworth, C. F., Wakefield, Mass.  
 Wyman, C. D., Milwaukee, Wis.  
 Woodruff, E., Atlanta.  
 Wylan, J. T., Macon, Ga.  
 Williams, C. H., Manchester, N. H.  
 Watty, G. E., Jamestown, N. Y.  
 Wakefield, R. S., Dallas, Tex.  
 Williams, Wm., Easton, Pa.  
 White, H. B., Chicago.  
 Wallace, Alfred, Columbia, S. C.  
 Wason, C. W., Cleveland.  
 Wendell, S. S., New Bedford, Mass.  
 Williams, S. A., Rochester, N. Y.

#### LIST OF SUPPLY MEN.

In addition to those who had space in the exhibition hall, were noted the following representatives of supply houses:

American Car Company, St. Louis.—E. J. Lawless.  
 Anniston Cordage Company, Anniston, Ala.—F. W. Jones.  
 American Iron & Bolt Company, Cincinnati.—G. M. Ball.  
 American Electric Manufacturing Company, St. Louis.—J. F. Gerliman.  
 Abendroth & Root Manufacturing Company, New York. P. McLaren, general manager.  
 American Engineering Company, Atlanta, Ga. C. H. Williams, G. Mays Ball.  
 George C. Ball & Co., Birmingham and Atlanta.—S. Mays Ball.  
 Bruner Brick Filler Company, Pontiac, Ill.—H. C. Bruner.  
 Brownell Car Company, St. Louis, Mo.—W. B. Allen.  
 Binghamton Wagon Company, Binghamton, N. Y.—J. H. McConathy.  
 Bushnell Manufacturing Company, Easton, Pa. E. M. Bushnell.  
 W. R. Brixey, New York.—T. G. Felder.  
 Mark D. Bachelord Co., Atlanta, Ga.—M. D. Bachelord.  
 B. & B. Manufacturing Company, New York.—E. M. Oswald.  
 Buckeye Engine Company, Salem, O.—G. A. Barnard.  
 Carnegie Steel Company, Atlanta, Ga.—W. M. Kelly.  
 G. S. Colgate Co., New York.—G. H. Colgate.  
 The Car, Philadelphia.—F. B. Vandegriff, W. E. Douglas.  
 Composite Brake Shoe Company, Boston.—G. C. Ewing.  
 Car Equipment Company, Philadelphia.—E. H. Allen.  
 Columbia Incandescent Lamp Company, St. Louis.—J. H. Rhoetemel, president  
 Central Union Brass Company, St. Louis.—T. C. White.  
 Dreher Manufacturing Company, New York.—H. H. Foster.  
 J. M. Emerson & Son, New York. C. S. Lyle.  
 Electric Publishing Company, Chicago.—E. L. Powers.  
 Electric Railway Equipment Company, Cincinnati.—S. J. Wick.  
 Electric Power Company, New York. H. A. Foster.  
 Fairburn Engineering Company, Chicago.—J. M. Cobbs.  
 A. French Spring Company, Pittsburg.—P. T. French.  
 E. S. Greeley Co., New York.—F. A. Magee.  
 Hughes Fare Register Company, New York.—E. Pecker.  
 Hoppes Manufacturing Company, Springfield, O.—W. H. Fisher.  
 Heine Safety Boiler Company, St. Louis.—E. D. Meir.  
 Hooper & Townsend, Philadelphia.—F. R. Case.  
 International Register Company, Chicago.—A. H. Englund.  
 Johns-Pratt Company, Hartford, Conn.—E. D. Hatch, H. Liscomb.  
 Jackson & Sharp Company, Wilmington, Del.—G. E. Pratt, J. H. Jackson.  
 Morris Tasker & Co., Philadelphia.—C. F. Flanders, S. Bowmann.  
 Morton K. Moore, Atlanta.—H. C. Harnady.  
 New Process Rawhide Company Syracuse.—A. C. Vosburgh.

New York Leather Belting Company.—H. Fairbrother.  
 Okonite Company, New York.—W. L. Candee.  
 Pettingill-Andrews Company, Boston.—F. X. Cicott.  
 Pomeroy & Fisher, New York.—J. Pomeroy.  
 Safety Car Heating & Lighting Company.—W. St. John.  
 Quaker City Car Equipment Company, Philadelphia.—J. E. Loughthide.  
 Railway Register Manufacturing Company, New York.—Ed Beadle.  
 Robinson Radial Car Truck Company, Boston.—W. Robinson.  
 Standard Underground Cable Company, Pittsburg.—F. G. Degeubardt.  
 Sterling Supply Company, New York.—J. H. Carson.  
 Southern Electric Works, Atlanta.—Fred Miles.  
 Sargent & Lundy, Chicago.—B. J. Jones.  
 Stanwood Manufacturing Company, Chicago.—T. H. Stanwood.  
 Vacuum Oil Company, Boston.—E. A. Record.



### A DESERVED HONOR.

At the meeting of the board of directors of the Meaker Manufacturing Company, October 23d, a deserved recognition was made of the services of John Meaker, Jr., in his unanimous election as secretary of the company. The REVIEW knows a great many young men who are rapidly coming to the front, but among them all there is none who more commands the respect and confidence of his friends and business associates than the gentleman named. The election is given as a recognition of able effort, and we congratulate the company and Mr. Meaker on a mutually desirable relation.

### THE LACONIA STANDARD TRUCK.

The big fire which last June carried away the street car department of the Laconia, N. H. Car Company, in no way discouraged that enterprising concern, and as soon as the ruins cooled sufficiently, work of reconstruction

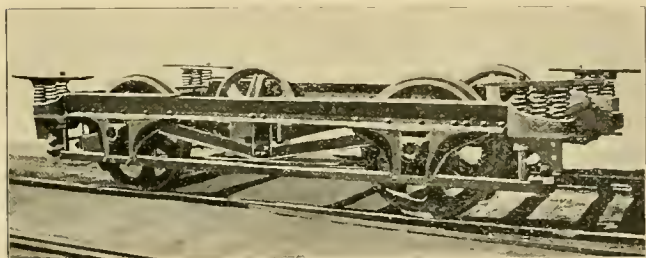

LACONIA STANDARD TRUCK.

was begun. The rebuilt shops are larger and with even greater facilities than before, and in the steam car department have a capacity of 175 first-class passenger coaches and 2,000 freight cars per annum; while in the electric department the capacity is 700 car bodies and 1,000 standard trucks. The car wheel works have a capacity of 15,000 wheels per year. The Standard Truck has been adopted by the West End road of Boston, on which lines 150 have gone into service since last March. The

features of the truck are simplicity of construction, low cost of repairs; a quick, powerful brake; material and workmanship of the highest order; rivets are all hot Norway iron; affords smooth steady riding. The photographs of this truck attracted much attention at Atlanta convention. Over 200 have been sold within the last six months.

THE Consolidated Car Heating Company, Albany, N. Y., which manufactures the Pope light, which, it says, is interchangeable with the "Pintsch," has added considerably to its plant and is about to manufacture on a large scale, lamps for compressed oil gas, and fittings. The compressed gas plant of the latest pattern recently erected, shows most excellent results, 17,600 cubic feet of 50-candle-power gas having been obtained from 160 gallons of oil, that is, 110 feet per gallon, heretofore the usual make having been under 90 feet. The Consolidated Car Heating Company is preparing to notify railway men from all over the country to witness an exhibit of Pope lighting apparatus at Albany, carrying out a similar plan to the one it established in 1892, with reference to steam heating apparatus, when special trains were run hourly between Albany and Troy during two days, for the inspection and investigation by prominent railway officials from all parts of this country and Canada to observe the operation of the Sewall coupler and commingler storage systems.

THE Mather Electric Company, of Manchester, Conn., reports a large number of orders on hand for its new multipolar generators for railway work. One of its 180 kilowatt improved new type multipolar railway generators, with complete station equipment, was sold to the Hartford & West Hartford Horse Railway Company, for the Hartford, Conn., power house. The generator is to replace a 200 kilowatt generator of Philadelphia manufacture, which, after a two weeks' attempt on the part of its makers to make run successfully, was thrown out. In thirty-six hours, after placing the order, the Mather Electric Company had the road running successfully in that short time, having removed the old and installed the new generator, which has given such perfect satisfaction to the purchaser that the Hartford & West Hartford Horse Railway Company has just placed a second contract with the Mather Company for two more 180 kilowatt generators with station equipment. The Mather Company has also sold, through its well-known western contractor, J. Holt Gates, of Chicago, a 100 kilowatt direct connected generator to the South Chicago City Railway Company, Chicago, Ill., and a 75 kilowatt generator to the Bloomington City Railway Company, Bloomington, Ill.; also a 100 kilowatt generator to John Jermin, of Scranton, Penn., for electric tramway. The Mather Electric Company is now installing two 100 kilowatt generators, with complete station equipment, in the new power station of the Danbury and Bethel Horse Railway Company, of Danbury, Conn., which road the company expects to have running in a few weeks.

## COMPOSITE BRAKE SHOES.

The composite brake shoe, made by the Composite Brake Shoe Company, of 620 Atlantic avenue, Boston, Mass., is meeting with a well deserved favor among

electric railways. It is manufactured under W. W. Whitcomb's patents, and has a number of wooden plugs on its surface. These plugs are

held in with a locking device. The shoe is on the market on its merits, and not on its price, and the company expects to

get business in places where merit and not low first cost is the prime object. To meet the demand remote from New England, arrangements have been made to have shoes made at Philadelphia and at Pittsburg. The exclusive license for the Pacific Coast has been granted to Edwin F. Tucker, of Tucker & Stein, at San Francisco, Cal., who will manufacture for that part of the country.

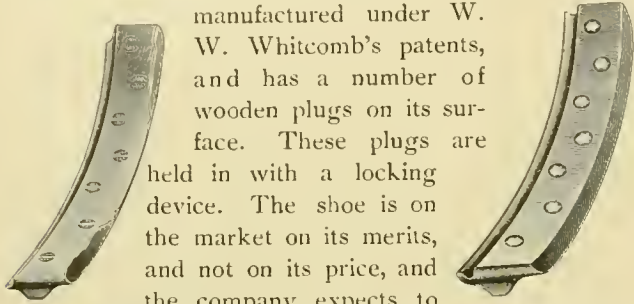

## VAN DORN AUTOMATIC DRAW BAR.

The Fitzgerald-Van Dorn Company, Lincoln Neb., is supplying elevated, cable, electric and street railways with an automatic drawbar illustrated herewith. It is claimed by the manufacturers that the cars couple solidly together. The link answers a double purpose, one end being auto-

matic, while the other makes a common pin and link coupling, and will couple to any other class of draw bars. There is said to be no buckling sideways when backing up. In addition to the

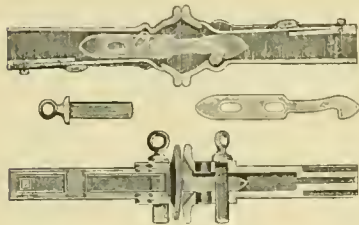

device shown, the company makes one with a ball and socket joint attachment to take up lost motion, and an ingenious bar for going up mountain roads to do away with the rolling motion of the cars. The company has a contract for furnishing draw bars to the Metropolitan Elevated Railway Company, Chicago.

P. F. LEACH, of the Cushion Car Wheel Company, called on the REVIEW.

**WARDWELL BROTHERS,**  
**Electric · Railway · Builders,**

NEW HAVEN, CONN.

BOX 868.

Will make proposals for the Construction of all Classes of Street Railway Tracks, Power Houses, Etc.

## PERSONALS.

H. G. MANNING has resigned his position as superintendent of the Watertown, N. Y., Street Railway.

CHARLES D. HAINES, who was president of the Owasso & Corunna Street Railway Company, Owasso, Mich., has been renominated for congress.

E. H. MATHER, late of the General Electric Company, has been made superintendent of the New Haven, Conn., Street Railway Company. Mr. Mather formerly resided in Schenectady, N. Y.

C. C. CALDWELL, the electrical engineer, is making an exhibit of electrical and mechanical, railroad and marine photographs, at the Rushville, Ind., fair. He made, by invitation, a similar exhibit at the state fair.

JAMES S. ALVES, president of the Henderson, Ky., Street Railway Company, sustained a heavy loss recently by the burning of his residence. The fire broke out soon after midnight and but for a faithful servant the sleeping family would have been burned to death.

CHARLES CLEMINSHAW, president of the Troy, N. Y., City Railway Company, was recently thrown from a car, sustaining a partial dislocation and sprain of the left ankle. The company was experimenting with a patent guard, which caught on the roadbed, bringing the car to a sudden stop and throwing out Mr. Cleminshaw.

## Half Fare.

Via the Baltimore & Ohio Railroad.

On November 6th and December 4th, the Baltimore & Ohio Railroad will sell Home-seekers' Excursion Tickets from Chicago to Winchester, Harrisburg, Staunton and Lexington, Va., and intermediate points at rate of one first-class limited fare for the round trip. Tickets will be sold only on the above dates, and they will be good for return 30 days from date of sale.

Complete information relating to lands for sale can be secured by addressing M. V. Richards Land and Immigration Agent, Baltimore, Md.

For further particulars in relation to tickets, rates, sleeping-car accommodations, etc., apply to any B. & O. R. R. Agent, or L. S. Allen, A. G. P. A., Room No. 411, Grand Central Passenger Station, Chicago.

**C. E. LOSS & CO.,**  
**General Railway Contractors.**

Estimates made on all classes of Engineering Work.

621 Pullman Bldg. CHICAGO.



WINDSOR & KENFIELD,

PUBLISHERS AND PROPRIETORS,

269 DEARBORN ST., - - - CHICAGO.

Published on the 15th of each month.

SUBSCRIPTION, - - - TWO DOLLARS.

FOREIGN SUBSCRIPTION, - - - 20 SHILLINGS.

Address all Communications and Remittances to THE STREET RAILWAY REVIEW,  
269 Dearborn Street, Chicago.

H. H. WINDSOR,  
Editor.

F. S. KENFIELD,  
Business Manager.

### CORRESPONDENCE.

We cordially invite correspondence on all subjects of interest to those engaged in any branch of Street Railway work, and will gratefully appreciate any marked copies of papers or news items our street railway friends may send us, pertaining either to companies or officers. Address:

THE STREET RAILWAY REVIEW.

269 Dearborn Street, Chicago.

Eastern Office, Room 14, No. 126 Liberty Street, New York.

This paper member Chicago Publishers' Association.

Entered at the Post Office at Chicago as Second Class Matter.

VOL. 4.                      NOVEMBER 15, 1894                      NO. 11.

It is stated that in a large western city there were two parallel lines of horse cars. A year ago each did about the same amount of business. Last spring one of the lines was converted to electricity, and now the ratio of travel is as 10 to 1 in favor of the electric line.

It is a pleasure to note the increasing tendency among city authorities to prohibit the use of the guard wire over trolley lines. Electric railway men have been opposed to them from the start, but city officers, actuated by ignorance and by the telephone companies, thought they knew better, and insisted on them. Time has proved that the electric railway men were right and that there are more accidents with guard wires than without them. Now that this is realized, some cities are going to the other extreme and prohibiting them, where the city electrician is a wide-awake and progressive man, who is willing to base his decisions on practical results and not on theoretical considerations or political pull.

THE chartering of special cars for an evening's ride and for theater parties and other similar purposes is a recent development in the electric railway field, which with a little encouragement on the part of superintendents, ought to become general over the country. The movement began in Philadelphia, where hundreds of special cars were chartered during the summer for "Trolley-ho" parties. The West End System, of Bos-

ton, has put on an elegantly fitted up car for theater parties, and so the work goes on. The idea is popular because it gives people a great deal better accommodations than they could get anywhere else, even for more money. The price can be very reasonable and still give a good return to the company.

A WORD of warning is in place just now to the builders of interurban roads. There is a great temptation to throw down 30 or 40-pound rails and a few ties under each length and let the track go at that. Many interurban roads will graduate from the same school of experience that city railways have been through as regards too light track. A piece of interurban track recently under our notice which has been in use less than six months and which consists of 40-pound rails on ties three feet apart has given down under a 20 minute service, so that the speed has had to be noticeably reduced. What its condition will be six months hence can only be surmised, but it is safe to guess that at least it will not be any better. And yet the laying of light track goes on, and the owners and builders seem to think that by some miraculous process the laws of the universe will be suspended in their particular case so that the building of a light track is not a waste of money.

AN average of four or five cases of cars taking fire from electrical causes are reported to us every month. To this should be added three or four cases more of employes and passengers getting shocks from parts of the car which ought never to be alive. While we have never heard of a serious accident from this cause, there must be something radically wrong with the general run of car wiring which admits of so many cases of this kind coming to public notice. Car wiring is often not as carefully done as 50-volt incandescent light wiring, although it must stand ten times the voltage. Setting fire to cars and treating passengers to free shocks is not conducive to inducing traffic among the timid members of the community, and the money spent in repairs of cars that have been set on fire might be better spent in better wiring in the first place. In this connection it is a good plan when overhauling or building cars to see that all metal work within passengers' reach is permanently and positively grounded by a connection with the truck frame.

ON the principle that wholesale prices are cheaper than retail, and that a large business can be conducted more economically than a small, it would be expected that a large street railway could be operated cheaper than a small one, but owing to the great differences in the prices of labor in small and large cities, and the other expenditures which operation in a large city entails and that in a small city does not, the reverse is proved to be the case. The publication of the operating expenses of several small roads, which have appeared in our last three issues, (and the end is not yet) show the lowest figures ever made public. Practically nothing has been published on

the expenses of small roads heretofore. Indeed it was impossible to obtain such figures, because very few of them kept itemized accounts, and still fewer figured results so that they could be compared. The fact that the small roads are now beginning to show up figures, proves that they are getting into better hands, and that an era of good management is dawning on them.

WE have been requested by Mendes Cohen, the engineer of the Baltimore car fender commission, to add a few thoughts to our necessarily limited abstract of his report on fenders which appeared in our October number. Although he appreciates fully the objections to fenders extending in front of the car, he thinks that the present danger of throwing the victim down and fracturing his skull on the pavement is sufficient to warrant their use, and, as stated in our abstract, he advocates the use of both wheel guard and projecting fender. On account of the liability of the scoop to fail in its work, he advocates the reduction of speed at crossings, "so as to better enable the timid or nervous person to effect the crossing in safety." Just what speed he recommends is not stated. We presume that this should be scientifically determined by the personal equation of whatever "timid or nervous" person happens to be on the crossing when a car is coming. About two miles an hour would be enough for some people and twenty-five an hour would be none too much for others. In order to know what is the proper speed for each individual, all motormen should be mind readers. On our part, we would recommend that cars be run fast enough to scare timid and nervous people so that they will not take any risks in crossing.

HERE is a little problem in arithmetic that is somewhat startling in its results at first sight, but which shows admirably the importance of speed, not only to good service, but to economical operation. An electric car running eighteen hours a day for 340 days of a year, with conductor's and motormen's wages at 20 cents an hour each, will require \$2,448 for trainmen's wages for the year. If horses do the same work, the speed will be about one half slower and two cars will be necessary, so that on the same basis \$4,896 will be taken for trainmen's wages. Very good electric cars, with complete equipment, can at present be bought for \$2,000 and under, and as the yearly saving in wages of trainmen by electric traction was seen to be \$2,448, the startling fact is deduced that the electric car saves more than its entire first cost every year by the reduction of trainmen's wages due to the increased speed. In other words, a road could completely wear out its electric cars every year and save money over horse traction on wages alone to say nothing of other items. It is not necessary to use this argument in support of electric traction, because as was said at convention, the introduction of electricity is an accomplished fact and street railway men no longer discuss its advantages or disadvantages as compared to other methods. The matter is mentioned here simply to show what

an important factor a large daily mileage per car is in economic operation. There is such a thing as overdoing the work required of a car, but the mistakes in management are usually in the other direction.

It seems to us that in the report of the executive committee the reference to those lines which had withdrawn from membership in the association during the past year was unnecessarily severe. The clause referred to reads: "The following companies have withdrawn; several of them having gone into the hands of receivers or leased to other companies, *and nearly all of them being very weak financially.*" The italics are our own and designate the words in question. It seems to us an ungenerous and uncalled for slur on ex-members whom the association was only too glad to add to its list and take their initiation fee of \$50, and while some or all of the member companies so withdrawing may have been passing through deep waters, there was no necessity for thus emphasizing their distress and holding them up to public gaze. A small road with its small income has to practice economies that the large and rich lines know nothing of, and we can easily see how such companies are going to think twice before sending in their application for a membership from which they cannot in some future stress of retrenchment withdraw without being classed as "being very weak financially." Section XVIII of the by-laws expressly provides for member companies withdrawing at any time they see fit, by giving written notice and paying up all dues. It reads as follows:

"Any member may retire from membership by giving written notice to that effect to the secretary and the payment of all annual dues to that date, but shall remain a member and liable to the payment of annual dues till such payments are made, except as hereinbefore provided."

Which goes to show the intent always was that members were always at liberty to sever their connection, and express provision was made therefor. As already stated, we consider the allusion uncalled for.

A VERY sensible suggestion was made the writer by a prominent exhibitor when at the recent convention. It was that the allotment of space be made in such a manner that the very large and heavy exhibits be placed with a view to easy and economical unloading from cars or trucks. Some of the heaviest displays at Atlanta were farthest from the unloading point, and in one case pointed out to us the expense to the exhibitor was fifty dollars for moving his display into place after it was landed in the building. The same expense was experienced in moving out. This could easily have been avoided by a little forethought on the part of somebody. Possibly it was the location selected by the exhibitor, but doubtless he would as willingly have taken a more convenient place had he known in advance the trouble and expense involved. Another suggestion which has previously been urged by the REVIEW, is that some well-known supply man who has attended several conventions be included



in the committee of local arrangement for exhibits, and that in announcing the plan of exhibit hall, the necessary information be given out which will enable exhibitors to select understandingly. It would also be an advantage to place exhibits of similar character in groups so that railway men can the better make comparisons of one with another. Heretofore the rule has always been to parcel out the space regardless of class, and first come was first served. But it was shown at Atlanta that it is possible to have all spaces practically of equal desirability, and all locations were good. We believe if the rail, fare register, overhead material and similar displays, of which there are always several of each, could be grouped together, the result would be not only more effective, but would insure an examination of all exhibits of any given class in which the delegate was specially interested and desirous of informing himself. We are not the only ones who would like to see the plan tried next year at Montreal.

LARGE street railway companies are being annually bled by a species of parasite inventor, and the sooner the nuisance is suppressed the better. It was for such a purpose that a committee was appointed at the convention on recommendation of M. K. Bowen, for the purpose of forming a protective association of some kind. The state of affairs can be best illustrated by citing a conversation which took place some time ago between the writer and the superintendent of a road which had its own extensive shops and which makes a great many of its own supplies. Some devices were in use which were made by the company and which were different, and in the opinion of the officers superior to anything that could be obtained in the open market, or had been used anywhere else, although their chief superiority was strength and simplicity. The writer was intending to give the REVIEW readers the benefit of a published description of these devices, but a request was made by the superintendent that nothing be published. As that gentleman is not in the habit of hiding his light under a bushel, and like all other truly progressive railway men is generally willing to give other managers the benefit of his experience, we were somewhat surprised, but on learning his reasons were fully convinced that they were legitimate ones. Several years ago the company in question made some simple appliances which could not be obtained in the market and which any mechanic of ordinary ability could design. Neither was there any great novelty in the use to which they were put. Nevertheless, within a week of the time that a description of them appeared in print, notifications began to swarm in from "dog-in-the-manger" inventors, saying that the articles were patented and demanding a royalty. The sum asked was usually not large, and rather than enter into an expensive patent litigation with each of the various claimants the royalty was in most cases paid. The aggregate of the royalties amounted to a good deal. Theoretically litigation was the proper course, but payment without lawsuit was no doubt the cheapest. Now

it is evident that not more than one or two of the many patents were anything more than worthless. The company we know is perfectly willing to pay a royalty on genuine inventions which involve something more than taking out a set of patent papers. Anyone acquainted with the patent office issues knows that there are a multitude of worthless patents, and unless some concerted action is taken these fake inventors will continue their blood sucking operations indefinitely. They toil not, neither do they spin, but they collect royalty just the same. We do not want to discourage those inventors who have spent thought, time, money and investigation on their inventions, but when a half a dozen different men can obtain patents on the same device and the said device has cost them practically nothing beyond the cost of taking out a patent, it can not be fair for each to collect a royalty. It is from such sharks that protection is needed.

PAVING next to the rails is given a great deal of attention by some companies. By others it is practically neglected. Neglect of this matter of detail is the most gross carelessness. As long as the paving is below the level of the tread or ball of the rail, well and good. The trouble is that the reverse is liable to be the case. Unless special care is taken, almost any form of block pavement will be laid so as to leave the rail below the level of the paving. We have seen it  $1\frac{1}{2}$  inches below. The result is bad in every way. The rail is down in a sort of ditch of its own, and whatever dirt falls on it stays there. This means that on an average American street, from twenty to fifty per cent more power will be required. Not only this, but the poor electrical contact between rails and wheels jerks the motors and makes the lights flicker. Indeed there is often more light under the car than in it, on a bad track. Not least of the troubles that come from too high paving are those undreamed of until winter sets in, and the superintendent wakes up some clear, cold morning, after a previous day's thaw, and finds the road frozen up as tight as a brick. If he does not find it so frozen up, it is because cars have been running frequently enough during the night to keep it clear. It is next to impossible to give a good service during the winter with such paving. Not only is too high paving bad from the company's standpoint, but it is bad from the public standpoint. A rail slightly above the street level is infinitely better and easier for vehicles than one below the general level. If the blocks are above the rail they are liable to work loose, and in any event the company's paving will only last a fraction of the time it otherwise would. A rail head level with the paving can be thoroughly cleaned with track brushes. If it is below, it never can be so cleaned, but must be swept off with hand brooms. As this is a course that is not likely to be resorted to, it goes without saying that the track is never clean. Add to these objections the one that teamsters are not as willing to turn out when in a rut an inch and a half deep as they would otherwise be, and altogether the low rail has a very bad case against it.



# IN THE POWER HOUSE

*This department is devoted to the construction and operation of electric railway power houses. Correspondence from practical men is specially invited. Both the users and makers of power house appliances, are expected to give their views and experiences on subjects within the range of the department.*

THE neatness and discipline on a man of war ought to be copied in every power plant large or small. It is the "Oh well, what's the use of being so particular" engineer that has the most trouble. Slovenliness in details will cover up other defects which would be noticed if nothing was allowed to remain out of order. Safety from fire, and the successful operation of electrical machinery both demand that things be kept clean and in order. A man is not fit for a position as engineer in an electric railway power station unless he is naturally neat in his habits. It is not his fault if he is born otherwise and he may be a conscientious and hard worker, but he is simply not cut out for being the engineer of such a plant and that settles it.

\*\*\*

THE question as to whether the generator is less reliable than the engine is an important one when it comes to railway power station design. If it is true that the generator, as built at present, is as reliable and no more likely to be broken down than the engine, the sooner the practice of having more generators than engines in a power plant is abandoned the better. Small generators are less efficient than large ones, and more expensive in proportion to their output, as well. If a company puts in two 100-kilowatt generators to each engine, and a 200-kilowatt generator to each engine will do as well, it is making an expensive mistake. The whole question lies with the relative reliability of engine and generator, the idea being that if two generators are connected to each engine and one of them breaks down, the engine can still help the station with the other generator. Two generators are twice as liable to break down as one, so that the supposed advantage of reliability is somewhat deceiving. The tendency at present is undoubtedly toward placing as much confidence in the generator as in the engine. Generators are much more reliable than a few years ago. There are still a few plants that give more than one generator to each engine, but their number is growing steadily less.

A PROMINENT electric light man once said that polished surfaces around stations do not pay dividends. That is very true and when polished surfaces make additional work that would not be required if they were painted over, by all means paint them. However, as machinery must be kept clean and it certainly is just as easy to wipe over a polished surface as over a painted one, there is not much to choose between paint and polish.

\*\*\*

A SMALL road six months ago found itself face to face with the following conditions: A line four miles long with a good traffic; a temporary power plant with a 100 kilowatt generator; a high speed engine of corresponding size belted to it and two return flue boilers. The station has been pulling five and six motor cars ever since and has been inoperative only forty minutes during running hours. Of course there have been some hair breadth escapes from the misfortune of a shut down and nothing but a grim determination to keep cars moving at all costs has made the record possible. On one or two occasions it was found advisable to keep a stream of city water running through the engine bearings, but a miss is as good as a mile and the trolley has been kept alive. Dynamos and high speed engines are not such ridiculously unreliable mechanisms after all.

\*\*\*

THE writer recently had the pleasure of looking at the results of some tests, made by the engineer of a plant, to determine the accuracy of several makes of indicator springs at various pressures. The results were not such as to make one place implicit faith in indicator cards, unless previous tests proved the indicator to be all right. The results of the tests spoken of showed errors in tolerably well known makes of indicators of from one to ten pounds from the bottom to the top of the scale. The indicated horse-power, as figured from cards taken by such indicators, would be something wonderful, and it is not hard to imagine a case in which the indicated horse-power of an engine would be lower than the output of the dynamo it drives. The lesson that the tests taught was twofold. First, get a good indicator, and second, keep it clean. Results obtained from a first-class and reliable indicator when dirty showed a far worse error than any that were obtained from the most inaccurate indicators when clean.

The following appeared in the correspondence column of the London Electrician:

SIR: As the question of employing high speed flywheels as accumulators of energy for electric traction has been raised in your columns by Mr. Archibald Sharp, perhaps I may be allowed to point out that in Vol. CXII. of the proceedings of the Institution of Civil Engineers for June, 1893, in the correspondence on Dr. E. Hopkinson's Paper on the South London Railway, I called attention to this very point, and suggested the advantage of employing for traction purposes engines of the steam turbine type, running, say, about 4,000 revolutions per minute, fitted with solid cylinder fly-wheels, say 3 feet diameter and 3 feet wide, and weighing about six tons.

A single fly-wheel of this description would store sufficient energy to maintain 66 H. P. for two minutes with a 5 per cent. variation in speed, and, of course, a proportionally greater horse power when the periods of variation between the maximum and minimum loads were less than two minutes, or, again, where a larger variation in speed than 5 per cent. was permissible.

A 3 foot wheel, running at 4,000 revolutions per minute, would have a peripheral speed of about 666 feet per second, but if of solid steel, would I believe, be quite safe, as I understand that considerably higher speeds are actually used with the similar fly-wheels employed for propelling the Howell torpedo. In any case, absolute safety could be attained by employing several wheels of smaller diameter arranged all upon the same axis.

No properly designed hydraulic power system is nowadays constructed without its accumulator, and, the conditions as to rapidly varying load with very short periods of maximum demand being analogous, it seems that plants for electric traction, as also perhaps those for electric welding, should be similarly equipped. For these, high speed fly-wheels on the engines or dynamos seem to be the most convenient arrangement for this purpose.—Yours, &c.,

A. A. C. SWINTON.

66, Victoria Street, S. W., August 11, 1894.

\* \* \*

THE exhaust injector is a device which has been on the market for a long time but is not seen very frequently among street railway power stations. In view of the fact that it is used in all the power stations of the Chicago City Railway, including the new electric station now being finished, it may be of interest here to quote from a paper read before a Chicago engineers association some time ago by Leander Haines, assistant engineer of that company.

"When first brought before the public, some eight or ten years ago, the exhaust injector did not meet with the great amount of enthusiasm among engineers that one might have expected; and yet when the ordinary injector was first brought out, the engineering world was taken by storm, as it were, but this can, I think, be better accounted for, because engineers did not at that time understand its principles, and many do not at the present day believe that the exhaust injector can accomplish its work with steam at atmospheric pressure. The statement appears too good to be true. Many engineers reach the hasty conclusion that an injector must have pressure of steam to operate it, and that this pressure must be supplied from the exhaust pipe, which would then act as back pressure on the piston of the engine; hence, under such conditions, there could be no economy by its adoption. Perhaps the most important point to be noticed in connection with the exhaust injector is its perfectly automatic action. When the conditions for working are right, with plenty of steam and water to meet the requirements, the injector will work steadily; but supposing that the conditions vary, as, for instance, the engine is running at varying speeds; then, when the supply of exhaust steam is too little for the supply of water, the injector ceases to work, but so soon as the engine again supplies the requisite or usual amount of steam, the injector again re-starts itself without any manipulation whatever, and will continue to work until steam is shut off from the engine, or the supply greatly reduced. When steam is wholly shut off the injector will suck all of the steam from the pipe, and the result is as remarkable to witness as it is beautiful to contemplate. The power or ability of these injectors to do work when using exhaust steam, is a point on which many engineers stumble, for they cannot clearly see how steam with no apparent pressure can compel water to enter a boiler against a pressure of from 75 to 90 pounds of steam. The following explanation of the operation of the exhaust injector will assist in making this problem more clearly understood.

Steam at atmospheric pressure will rush into a vacuum with a velocity of 1,888 feet per second, while steam at 110 pounds pressure, flowing through an open pipe into the atmosphere will have the same velocity. From this we learn that steam at no pressure in the atmosphere will flow into a vacuum with about the same energy as steam of 110 pounds pressure escaping freely into the atmosphere. To understand this clearly, we must consider that in one case, the steam in its escape strikes nothing, while, in the case of the higher pressure steam, it comes in contact with air, which, acting as a cushion, retards its flow, so that its effective energy is reduced. This is the key to the mystery of the exhaust injector, and I trust it has been made sufficiently plain for your comprehension. The velocity of steam given above may be verified by consulting any standard author on the theories of heat and steam.

\* \* \*

### Heating Feed Water in Condensing Stations.

BY B. J. ARNOLD, CONSULTING ENGINEER, CHICAGO.

I noticed in your September issue a letter from G. H. Leonard, of the Newton and Boston Railway Company, in which he asks for suggestions regarding the best way of heating feed water for railway stations when using compound condensing engines. The plan which has been followed by myself and others with good results, is to deliver the feed water into a tubular heater through which the exhaust steam from the condenser cylinders and the boiler feed pumps passes on its way to the atmosphere. The feed water is here heated to about 135 degrees. From this heater it is lead into a fuel economizer composed of vertical cast iron pipes around which the heated gases from the furnaces pass on their way to the stack. In this economizer the feed water is raised to 300 degrees Fahr., before it enters the boilers, if they are set with ample stack capacity.

In many stations now operating, if a pyrometer is placed in the smoke stack in the rear of the boilers, it will be found that the escaping gases range from 450 to 700 degrees, and generally about 600. With gases at this temperature the economizer will be found to effect a very material saving in fuel.

\* \* \*

### Sawdust Fuel and Other Matters.

BY AN ENGINEER OF A SMALL STATION.

We have made a great saving in fuel this summer by using sawdust. In May last we put in a chain conveyor to take the sawdust from the car door and feed it into the furnace by spouts from overhead on each side of each boiler. This is no new thing but it is new to most plants except saw mills. We have run our line since June 1, at a cost of \$5.25 per day of 18 hours, for fuel, with 11 miles of track and 10 motor cars running all the time, and trailers when needed, so that it will be seen that our fuel bill has been light for five months past. We use a 240 horse-power Allis corliss condensing engine and return flue boilers 66 inches by 16 feet. The station has been running since August 1893, and uses artesian well water that is very hard. For scale we use kerosene oil, feeding it by the drop at the rate of one quart a day. We feel a little proud of our engine performance. Since we started the plant August 4, 1893 we have run

every day from 16 to 18 hours, making an average of over 550 hours per month, and with one engine and two generators the cars have never been stopped during running hours more than a few minutes, the only cause of delay being the opening of the circuit breaker by overload, short circuit on the line, or lightning, except once when the station was shut down at 8 p. m. until the next morning. During fair week here we ran 25 well loaded cars with the above outfit. There is a Heine water tube boiler in this city and after seeing the sediment taken out of it this fall after two years use I am free to confess that the tubular are the best. There is a great claim as to the water evaporation of water tube boilers which we fail to "see" as we believe there is more circulation without any more steam. I have known of some instances of this kind. For fire purposes we like a good duplex steam pump with hose at hand but the main thing is to have a perforated steam pipe under every part of the roof and over the generators. This will put out fire without wetting the plant. No under the floor wiring for me. Overhead is the safest from water or grease from scrubbing the floor, and safest from grounds. I would use simple condensing corliss engines in all railway work over 100 horse-power and under 600 horse-power. They are quicker to feel variations of load than compound, and cheaper to run than high speed. Any number of generators can be run from one engine with proper clutches but it is better to have reserve power than to depend on one engine although the engine is more reliable than any generator that I know of.

\* \* \*

#### Direct Connected Units.

BY "ONE OF THE OLD SCHOOL."

Everything at present seems to be going to direct connected generators, and while we will probably be laughed at, there are still a few of us that are a little doubtful about direct connection being the unqualified blessing it is cracked up to be by manufacturers and constructing engineers. By direct connection I mean the placing of the armature on the engine shaft. I am willing to admit that a belt drive is a nuisance, and that a rope drive is a nuisance, but it is still an open question in my mind whether there are not features about direct connection that are nearly as bad as belt or rope drive. I know a number of practical operating engineers who are opposed to it on the ground that they have never yet seen a direct connected unit that was running in what could be called a satisfactory manner. Now, this is certainly a serious charge, and rather takes the breath away from some people who have been lead to believe that direct connection is beyond all doubt the best thing, so that it behooves us to investigate a little. The first impression of a man entering a station where direct connected railway generators are at work, is that there is an Indiana frog pond somewhere in the vicinity, and that several hundred varieties of frogs are yelling at the top of their voices.

After a little investigation, however, he finds that it is the commutators and carbon brushes. After more investigation he finds that the brushes spark badly under changes of load, and that the commutator, unless it is a new one, is in a generally demoralized condition. If it is not in such a condition it is because it has been turned down about six times to what would have been once if it was a direct connected machine. Belts cost something to maintain, but how about the commutator, which is the most expensive part of a direct connected generator? The commutator on a belt driven generator will last at least five years in daily railway service, if well taken care of, and probably much longer. I doubt very much if the commutator of a direct connected generator would last three years in daily railway service under similar conditions.

Now, what is the cause of all this? It is simply the fact that it is impossible to adjust an engine on a railway load, so that there will be no play or pound in the bearings at any time. When the armature is on the engine shaft this slight movement acts to slightly change the relative position of commutator and brushes each revolution, and trouble with the commutator soon begins. I know some one will say that an engineer has no business to let his engine pound, but with a railway load it is an impossibility to avoid it a part of the time. Beside the commutator trouble there are continual shocks on an engine when direct connected. Variations come quick as a flash, and there is absolutely nothing to cushion them. With a direct connected unit, especially in the smaller sizes, the oil that is always flying around an engine gets on the generator, and we all know what that means.

I know of some engineers operating stations that are unqualifiedly in favor of direct connection for all sizes of units, and I stand ready to be convinced myself, and would like very much to hear more from the other side of the house, and especially from engineers who are actually operating direct connected railway generators at present.

#### THE HOFFMAN CASTING PROCESS AT ST. LOUIS.

Visitors to the convention will remember the exhibit made by A. Hoffman, of the Falk Manufacturing Company of Milwaukee, which consisted in showing in actual operation his process of casting rail ends together and as would naturally be expected the process attracted a great deal of attention, because if it proves to be what its inventor claims it to be, it will do away with electric welding of rail joints on account of being cheaper than the welding process. Three miles of track are being supplied with these cast joints on one of the National Railway Company's lines in St. Louis. As it will be done under the same conditions as the welded track laid there last spring, the coming winter will afford an excellent opportunity to compare the two methods as well as to determine the effect of cold on a continuous rail.

## CONSTRUCTION AND OPERATION OF SMALL STREET RAILWAYS.

A Paper read before the Michigan Street Railway Association by  
W. Worth Bean.

Construction, maintenance and operation of small street railways is the subject on which the president has requested me, as a committee of one, to prepare a paper to be read at this meeting.

First. In the construction of small street railways as much care must be taken and even more than in the building of large street railways. Proper and substantial road beds must be prepared in order to receive the ties and rails. White oak ties of the best quality should be used, varying from two feet to two feet eight inch centers. Ties 5 by 7 inches and 5 by 8 inches 7 feet long, should be used according to weight and height of rails, except joint ties, which should be 6 by 12 inches 7 feet long. Every tie should be thoroughly tamped. Steel rails of girder and T pattern and first-class splices and nuts and bolts should only be used, according to location and surroundings and rails put to perfect gauge and the track lined and surfaced in the best possible manner. The writer finds in sandy districts that 3 inch by 10 inch and 3 inch by 12 inch pine plank 12 to 16 feet long, properly nailed to cross ties, and plank 3 inches by 12 inches wide placed on the outside of the rails makes a thorough and complete construction, which braces the track in every way, and also makes an excellent road for wagons and buggies to cross over and drive on. If permitted by city councils the head of the rail should extend at least one-half inch above the plank and the grade of the street. The greatest error that has prevailed heretofore, with few exceptions, has been the cheap and imperfect manner with which small street railways have been constructed. The idea has been to see how cheap a small street railway could be built by having hemlock and cedar ties of small dimensions placed too far apart, and rails of too light a pattern, both put down in the cheapest possible manner, so that all that can be said is that a street railway has been constructed. Curves and switches should also be made of T and girder rails of the latest and best approved patterns, and constructed in the best possible way known to street railway building. Great care should be taken to see that every joint is thoroughly bonded with large, soft-drawn copper wire and channel pins of the best manufacture. From experiments already made and the actual construction of tracks in Boston and St. Louis, it seems that the era of a new day has dawned upon us by the use of the continuous rail and the eliminating of bond wires, the splice bars, nuts and bolts, and sinking of joints which is so disastrous to tracks and cars. With electrolysis eating and corroding the water and gas pipes in various cities as published in different journals, the breaking and disconnecting of bond wires at the joints and return current going in the ground, which costs money at the coal pile, it is hoped the year of jubilee has come in the construction of street railways. If

the streets through which small street railway tracks are laid, or are to be laid, are paved, or are to be paved in a short time, brick or asphaltum should be used with the continuous rail (provided the company has the necessary funds) which to the mind of the writer, would almost be a perfect track.

OVERHEAD CONSTRUCTION.—The overhead construction of an electric railway should be put up of the best and most substantial material that can be bought. Iron poles ought to be set in the business portion of the city, and cedar in other parts. Switches, frogs and overhead curves should be of the safest and best construction. Feeder wires of large size, with good insulation, should be put on the poles in a substantial manner, and lightning arresters connected at short distances along the line or where feeders are connected with the trolley.

SECOND—MAINTENANCE.—In keeping in repair street railway tracks, the first important thing to observe and do is to keep the tracks at perfect gauge at all times as well as in line and surface. The bond wires should be tested by taking instrument readings at frequent intervals, and defective ones should be replaced at once, for economy at the coal bin or oil tank. If the continuous rail is used, only gauging, lining and surfacing need be done. Road bed and tracks should be well drained and kept free of snow and ice, so that water can not settle around the ties, and lower the joints and rails by motor and trail cars passing over the same. Frequent inspection should be given the lightning arresters and overhead construction, and all kept in good repair.

THIRD—OPERATION.—Last, but not least. The operation of small street railways has a checkered career. In the first instance, to build and maintain a small street railway, as above described, or as some railways have been constructed, and operate them with economy, is what presidents, general managers, superintendents, directors and stockholders have been looking for. In operating a street railway in summer, there are two motives for keeping the rail free from dirt and sprinkling the track: First, that the motors may be kept clean and in perfect order. Second, that the passengers may not have a cloud of dust following them by day and night, and making their lives unbearable, as well as spoiling their clothes. This is all different from operating in winter, when sleet and snow fall on the tracks and trolley in all their force and fury, and all the vehicles in your particular community seem to be on the tracks in front of the cars to cover the rails, that have just been cleaned, with snow. It is then that a manager thinks his burdens are more than he can bear. To make a small street railway a dividend payer, and to have genuine and unadulterated business fun, add 100 arc lights and 2,000 incandescent lights to your street railway service, and put a telephone in the station and one in your house, and then you have a first-class electric circus. I am a firm believer in the electric car heater after two winters' service, and do not see how electric heaters can be dispensed with. Great care should be taken in the selection of motormen and conductors, and all reasonable rules rigidly enforced to prevent accidents from front end

of cars, and to look carefully after passengers at rear end of cars, and, most important of all, collect and register all fares. The oasis in the desert, if there be such, for the manager, is to provide for the entertainment of passengers along and at the ends of the lines, to keep up the revenue, and make the stockholders financially happy.

The past summer the writer has had comedy companies, distribution of groceries, bands of music, picnics, dances, etc., at the pavilion terminus of his line, and they have all largely increased the revenue of the company.

As each year rolls by, it is to be hoped our ways and means will not be exhausted to largely increase travel, in the operation of small street railways, which are so essential to small towns and suburban districts and the entire growing population. The writer commenced the construction and operation of a small street railway in Kentucky in 1879, and is much pleased with the great strides made in the street railway field in so short a time.

foliage and American beauty roses. The guests were 150 from Rock Island and 20 from Chicago.

Kind friends remembered Mr. and Mrs. Kenfield with many costly presents. The bride's father handed them a check for \$5,000. The groom's gift to the bride was a diamond ornament, which she wore at her throat. The bride's father, Edward D. Sweeney, is a prominent citizen of Rock Island, both financially and socially. He is a member of the firm of Sweeney & Walker, the oldest firm of attorneys in the city. Among his clients is the Chicago, Burlington & Quincy Railroad Company. Mr. and Mrs. Kenfield are traveling in the south. They will make Chicago their home on their return, which will be in December.

### TWO HANDSOME CARS.

Two handsome cars were sent to Atlanta by the Barney & Smith Car Company, Dayton, O., and run on the



TWO BARNEY & SMITH CARS.

### KENFIELD—SWEENEY.

On October 24, Fred Standish Kenfield, of the REVIEW, relinquished the joy of single blessedness for the comforts and greater blessings of married life. The young lady of his choice was Miss Amy Sweeney, one of the belles of Rock Island, Ill. It was a very pretty wedding, having been solemnized in the home of the bride. The parlors were decorated in white and gold. In the south parlor was a temporary altar, where the bridal party met, and the nuptial knot was tied by Rev. F. W. Merrill. The maid of honor was Miss Marion Lobdell, of Chicago, while Hiram J. Kenfield was the best man. The Misses Bessie and Gracie Noftsker, cousins of the bride, preceded the bridal party, and formed an aisle with white satin ribbon. The dining room in which the wedding supper was served was decorated with autumn

Atlanta Consolidated lines during the convention. Car 575 was built for the Cincinnati Street Railway Company and the view shown is the rear end of the car. Car 230 is one of the cars recently completed for the City Railway Company, of Dayton, showing the front end with round vestibule. Both of the cars are mounted on Barney & Smith standard double spring trucks. The cars are finished in cherry with plate glass windows and upholstered with spring cushion. The cars caused much favorable comment on account of the easy riding.

### MILEY—LAVELLE.

Charles E. Miley, superintendent of the Springfield Railway Company, was married recently to Miss Agnes Lavelle, at St. Raphaels' Church, in Springfield, Ohio.

A COMPARISON OF RHEOSTAT AND SERIES-PARALLEL CONTROL.

We show herewith some curves giving the results of tests made by the engineering department of the General Electric Company on the comparative current required with rheostat and with series-parallel control. Figure 1 is the typical starting curve obtained from the two methods. The rheostat is of course the one showing the heaviest current at first. We are informed by the engineering department of the above company "that the conditions were exactly the same in both tests, the same motorman operated the car, and the start, so far as could be observed, was identical in each case. The speed at

wasted with rheostat control. This occurs only to a limited extent with series-parallel controllers. When 22.5 miles an hour is reached, in the curve Figure 2, the motors are in parallel with all resistance cut out, and require, of course, the same power. A saving of 40 per cent is shown in favor of the series-parallel control on the lower speeds, which amounts to a good deal in most cities, as different running speeds are usually absolutely necessary.

The power required in starting with series-parallel control is very nearly that required for running at full speed, the only jump that the current takes being when the motors are thrown from series to parallel.

The points on the type "K" controller are as follows:  
 1. Motors in series and all resistance in circuit.

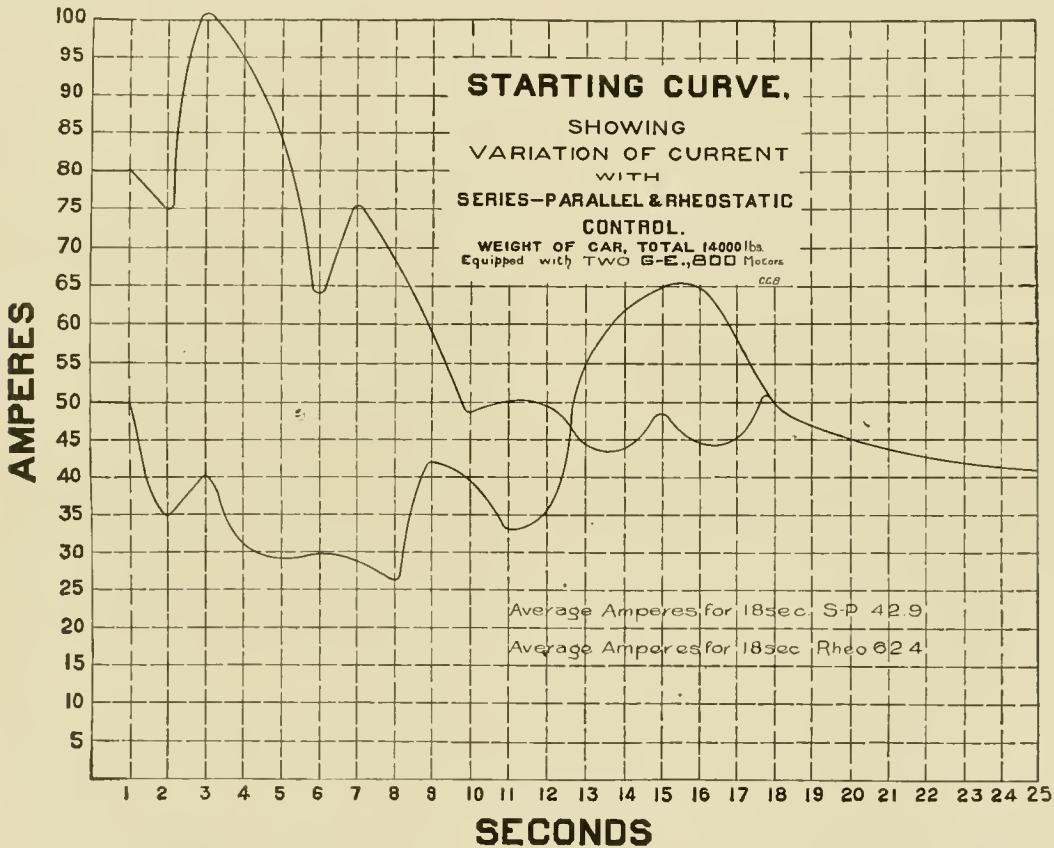

FIG. 1.—RHEOSTAT AND SERIES-PARALLEL CONTROL.

the end of 25 seconds was approximately 22 miles an hour. The same car was used for both tests, being wired for both the "K" controller and rheostat. The car itself was 16 feet, closed; weight, with load, about 14,000 pounds. In the starting curve, Figure 1, the time occupied in starting was 18 seconds. This, while good practice, is, perhaps, a longer time than usually taken, and on starts made in 10 seconds, the curves were, of course, considerably higher for both rheostat and series-parallel, but each had the same characteristics and the comparative energy for each was the same as in the 18 seconds' start."

Figure 2 shows the comparative power taken at different running speeds by rheostat and type "K" controllers. For the slower speeds much power has to be

2. Motors in series and half resistance in.
  3. Motors in series; resistance all out.
  4. Motors in series and a shunt around the fields.
  5. Same as 2.
  6. One motor cut out; the other in series with half the resistance.
  7. Same as 6.
  8. Motors in parallel; half the resistance in.
  9. Motors in parallel; no resistance.
  10. Motors in parallel; shunt around fields.
- Points 5, 6 and 7 are simply transition points.

The use of the field shunt (which takes the place of the field loop formerly used by this company) makes it possible to have four running positions with which there is no resistance in circuit where otherwise there

would be only two. This is an aid to the economy and smoothness of starting, as well as an efficient

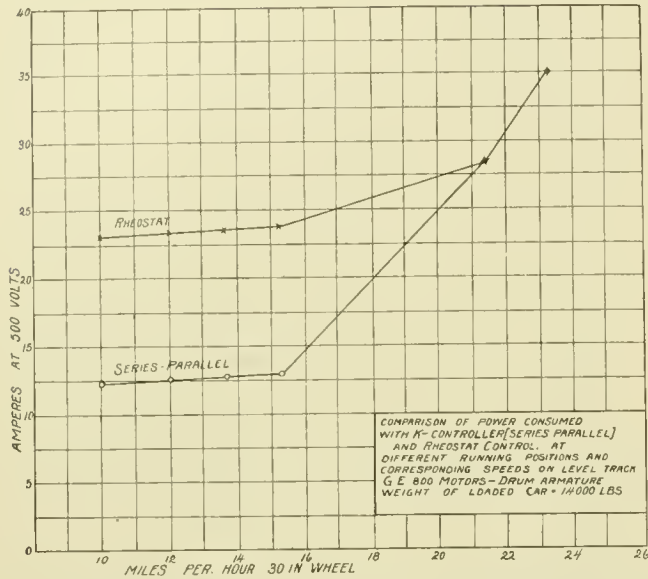

FIG. 2.—RHEOSTAT AND SERIES-PARALLEL CONTROL.

arrangement for use on crowded streets where several speeds are desired.

### MECHANICAL POWER NEEDED IN CALCUTTA.

There seems to be a pressing need for electric or cable lines in Calcutta, judging from the following taken from the last number of *Indian Engineering*, published in that city. It says: "The regularly recurring hot season brings in its train a list of casualties among the Tramway Company's horses in Calcutta, as well as other places where this system of locomotion is in vogue, which is heart-rending. But apart from this, which is practically rather a shareholder's point of view, there is much to be advanced from the point of view of the public against relying upon beasts of burden for the regularity and certainty of their reaching their places of business, considering the value and increasing importance of every moment of time. In such centers as Calcutta, Bombay, Madras, etc., nothing short of mechanical power should be insisted upon for the working of tramways since such power is unaffected by weather, and journeys may be timed with fair accuracy, which it is impossible to do when animal power is relied upon. The daily traveler by tram in Calcutta knows only too well by the stoppages which result from the use of too fresh or too stale horses just when pressed for time, or by the snail pace rendered necessary in the hot weather, what the inconveniences of the present system are, and he is fully entitled to have a grumble when he reads of electric and cable tramways adopted in places where nearly everything is in favor of animal power. There seems to be no potent reason why the tramways in Calcutta should not be converted into cable, if not into electric, tramways to the much greater convenience of the public using them."

### PENALTY FOR OBSTRUCTING STREET RAILWAY TRACKS IN OHIO.

The penalty in Ohio for willfully obstructing street railway tracks is severe, and under the revised statutes reads as follows:

"That it shall be unlawful for any person or persons, without proper authority, to place any obstruction upon any railroad, or any street railway, or any cable railway in this state, or displace, injure or destroy anything appertaining thereto, or interfere with, remove, displace or disarrange any rail, cross tie, switch, side-track, locomotive, car or train of cars, or other property appertaining to any such railroad, street railway or cable railway, or interfere with, remove, displace or disarrange any flag, lamp or other signal attached to or employed upon any railroad, street railway, or cable railway, or upon any railroad car or train of cars, or upon any street railway or cable railway car, locomotive, switch or other property appertaining to any such railroad, street railway or cable railway, or remove from, disarrange or destroy any lock, fastening, coupling or attachment on any track, car, switch, stand, tool house, depot or property of any such railroad, street railway or cable railway. Any person violating any of the provisions of this section shall, upon conviction thereof, be fined not more than five hundred nor less than twenty-five dollars, and imprisoned in the penitentiary not more than ten years or in the county jail not less than thirty days."

### SHE HAD GROWN.

Two women got in a street car, says the *New York Sun*, one with a long legged little girl. She gave the conductor two fares.

"Five cents more. You'll have to pay for that child, ma'am."

"Pay for Laury? Well! well!"

She opened a leather purse to look for pennies. With difficulty they were fished out separately. Meanwhile she discoursed:

"D'ye see, Laury? I'm payin' for you. Ye can't sit on mammy's lap any more. She's always climbin' for my knee."

Addressing the car: "She's our only one. Laury, ye must tell your paw, you're a little lady now; ye've been paid for. Ye can't sit on mammy's knee no more. Dear me, how time flies." She took in the car with a comprehensive glance, then turned on her friend by her side. "It don't seem no time at all since Laury was born. Rebecca, you remember, or was you away from home? It was that warm. But Laury's a little lady now. She's been paid for."

The long legged girl leaned shyly against her mother, who put her arm around the child and pressed her to her side. The amused smile of the car changed to one of sympathy, and a lonely old fellow in the corner with speckled silk stockings had a tear in his eye.



ELLIS COMPANY'S SELLING AGENTS.

The Ellis Manufacturing Company, Philadelphia, manufacturers of the Hansell equalizing motor truck, for electric or cable railways, have a corps of bright selling agents, who, singularly, have all had a long experience in the iron and steel business. L. S. Boomer, the Chicago representative, has his office at 647 Rookery. He began his business career in 1872, in the bridge business, continuing for ten years, being a portion of the time a partner with his father in a large Canadian contract, and latterly, with the American Bridge Works, of which he was secretary. His next field was with the Gautier steel department of the Cambria Iron Company, and Park Brother & Co., Pittsburg. In 1891 Mr. Boomer returned to Chicago, having secured the agency for several leading Eastern steel manufacturers, and has since devoted his time to working up business for these interests.



L. S. BOOMER.

Harrington, Robinson & Co., 10 Oliver street, Boston, are the New England agents. The firm consists of George W. Harrington and John C. Robinson, who succeeded to the business of Arthur G. Tompkins, in whose employ they had been, and Joseph A. Brainerd. Mr. Robinson, who has charge of the railroad department, will come in direct contact with the customers of the Ellis Manufacturing Company. Those who know him need no introduction, but there may be a few to whom his likeness may be unfamiliar. The firm also represents William Wharton, Jr., & Co., (incorp.) Philadelphia; Wharton Switch Company, Jenkintown; Glasgow Iron Company, Pottstown, Pa.; A. & P. Roberts, Morris,

respected Virginia families, his father being the late Dr. Minnigerode, one of Richmond's most honored Presbyterian ministers.

J. T. Dudley, 136 Liberty street, New York, is also an iron and steel man who represents the Ellis Manufacturing Company in New York and the upper part of New Jersey. He is a young man who has made for himself a position among the best salesmen in his line, and a host of valuable acquaintances.



J. C. ROBINSON.

AERIAL CABLE IN ENGLAND.

There has recently commenced operation, at Brighton, England, an aerial cable way, built by the Telpher Cable & Cliff Railway Syndicate, upon plans made by W. J. Brewer, C. E., the inventor. The line spans the Devil's Dyke, and is 230 feet above the valley. A sort of suspension bridge is used to support the cable. The supporting pillars are 650 feet apart, and the bridge is further supported by anchors, 1,200 feet apart, buried in cement on each slope. The journey from hill to hill requires 2 1/4 minutes. It is said that when the cable is slack, there is a swaying motion similar to that of a vessel at sea. The cable is endless, and the motive power is an oil engine.

The company intends to build several branches over other valleys in the vicinity. The value of this system is said to consist in the cheapness of construction as compared with the cost of bridges spanning distances across rivers or between mountains, where difficult engineering problems exist, that would be expensive to overcome.

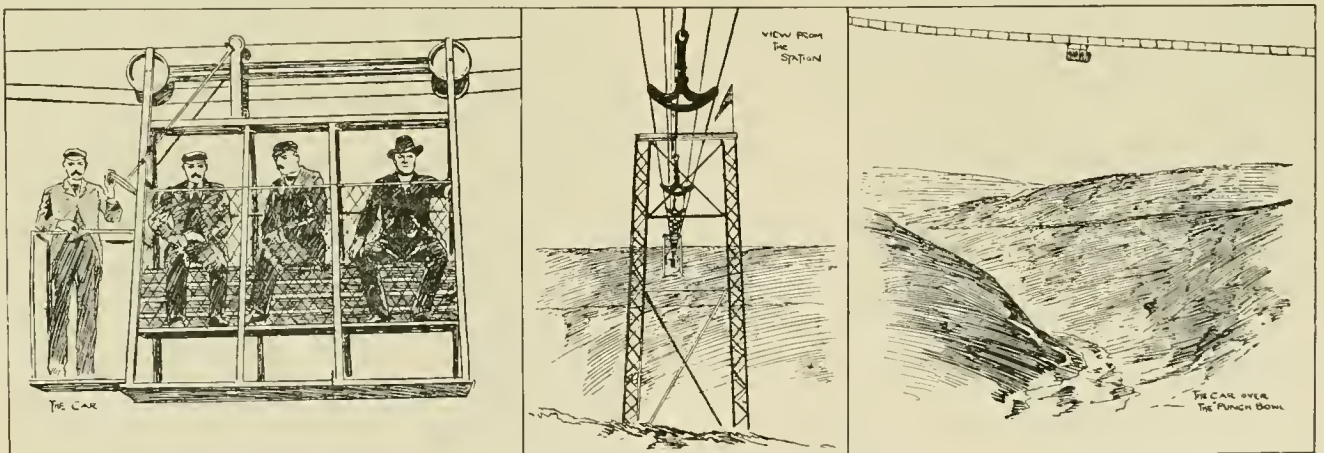

AERIAL TRANSPORTATION, BRIGHTON, ENGLAND.

Tasker & Co. and Hoopes & Townsend, Philadelphia. William Minnigerode, 216 South Fourth street, Philadelphia, is one of the best known gentlemen in the iron and steel trade in the Southern states, having been in business and located at different times in Richmond and Lynchburg, Va.; Atlanta, New Orleans and Birmingham, Ala. He comes from one of the oldest and highly

This new system of transportation is attracting a great deal of attention in England, resulting in many interesting speculations regarding its future development. Some sanguine people even venture the opinion that it is the solution of the problem concerning the bridging of the British Channel, which has been fruitful of so much discussion, and productive of many foolish plans.

## STREET RAILWAY MAIL SERVICE.

The recent inauguration and successful operation of a mail service on the lines of the Atlantic Avenue Railroad Company in Brooklyn and its suburbs, is another demonstration of the utility of street cars in carrying local mails. As at St. Louis, the service has been proved a



BROOKLYN MAIL CAR.

great convenience to the public, an economy to the government and a source of profit to the railway company. Managers who contemplate establishing a mail service will be interested in reading an account of its inception, for which the REVIEW is indebted to President Benjamin Norton, of the company, and Postmaster A. T. Sullivan, of Brooklyn.

The idea originated with Mr. Sullivan over a year ago. He obtained the sanction of the postoffice department at Washington and conferred with representatives of the Atlantic Avenue Railroad Company. The company's officials met him more than half way and have cordially co-operated with him from the beginning. Designs were furnished for two special cars by Postmaster Sullivan and the railway mail department, and the company built the cars. A motorman and conductor are furnished by the company and the clerk who handles the mail is a regular employe of the postoffice department.

The car is twenty-eight feet long and is divided into two equal sections by a partition across the middle. Its exterior and the interior of the mail section are shown in the engravings. The forward half is fitted up for the railway mail service, with iron racks for the pouches, a distributing table extending all along one side for the sorting and stamping of mail matter, and with a set of pigeon holes for distributing. The windows are protected by wire netting, so that they may be opened in warm weather without the possibility of any mail matter being blown out and lost. All exposed woodwork is of polished maple and the roof is finished in white enamel with gilt ornaments. The car is warmed by electric heaters. The outside of the car is finished in white enamel with red stripes. The lettering on the side is in gold. Both cars are alike inside and outside and the cost of each was \$1,900.

Three trips are made daily, delivering to and receiving mail from nine postoffices between the main office in Brooklyn and Coney Island, besides given partial service to two other stations. Owing to an injunction restraining the company from running through cars to Coney Island, it has been necessary to transfer the mail at one point from car No. 101 to No. 102, but now that the line has become a mail route, the company may obtain a counter injunction to prevent the obstruction of the United States mails. The car runs on a schedule. At a certain hour in the morning it arrives at the general postoffice to receive the sacks and pouches. Stops are made at twelve points at certain hours to deliver the sacks of outgoing mails to carriers who are in waiting, and to receive from them the incoming mail. All of the mail received on the car is stamped by the clerk and distributed to the respective pigeon holes and sacks, thus effecting a saving of time, which is one of the principal objects of the postoffice department.

The trial trip was attended by representatives of the postoffice department and of the Atlantic Avenue Railroad Company. Schedule time was made and the mail was handled without a hitch.

The street railways of Pittsburg, Pa., are co-operating with the postoffice department to give that city a better mail service. As yet the improvement in the service extends only to the use of regular cars as carriers of

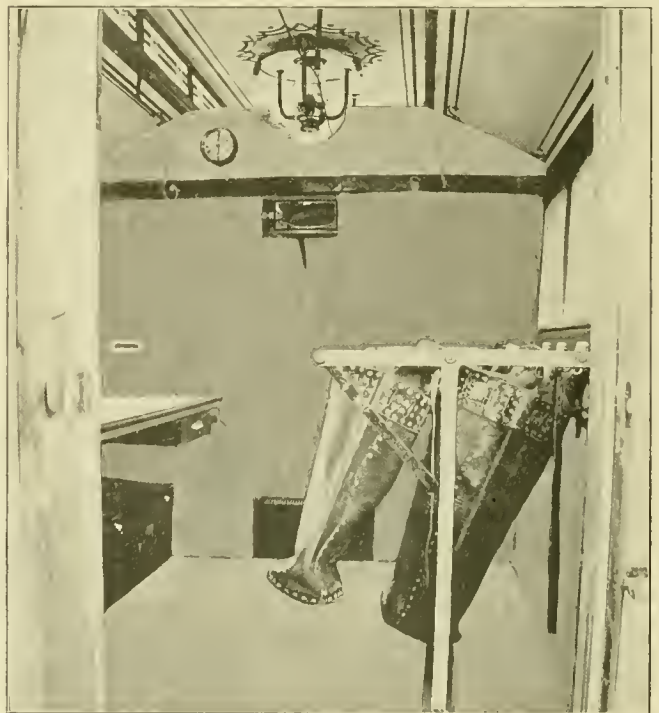

INTERIOR MAIL CAR.

mails from one station to another. In time special cars may be employed, as at Brooklyn, on which to distribute mail matter en route.

The first of Pittsburg's numerous traction companies to receive the honor of carrying Uncle Sam's mail is the Pittsburg Traction. G. W. Elkins, president of the com-

pany, has accepted a proposition of the government to transfer the mail from the central postoffice to Station A in East Liberty, a distance of five and one-half miles. The contract becomes effective November 15. The mail pouches are carried on the platforms beside the gripmen and motormen, in whose custody they are. Every employe of the company will be sworn into the government service, and each car carrying mail bears the inscription "U. S. Mail."

The next to carry mail will be the Citizens' Traction Company and the Birmingham Traction Company. Contracts with these two companies have been submitted to the department at Washington for approval, and they will begin carrying mail not later than January 1, 1895, between the general office and Stations B and C.

Negotiations are now being carried on with the Allegheny Traction Company for the transfer of mail from the Pittsburg to the Allegheny office. This com-

declaring that each company has acted nobly in the endeavor to give the city of Pittsburg an improved mail service.

A PECULIAR CURVE AT CINCINNATI.

The accompanying plan of a piece of special work recently put in at the intersection of Glenway and Wilder avenues at Cincinnati shows a peculiar method of avoiding a switchback or a heavy curve on a grade. Both the up and down cars make the loop in the same way and the curve is entirely on the down grade. If this curve had not been put in as it is, it would have been necessary to have either a switchback and change ends at this point or else have a curve on a very steep grade. The special work was made by the Johnson Company, Johnstown, Pa. This construction has attracted a great deal of attention from experts on account of its novelty.

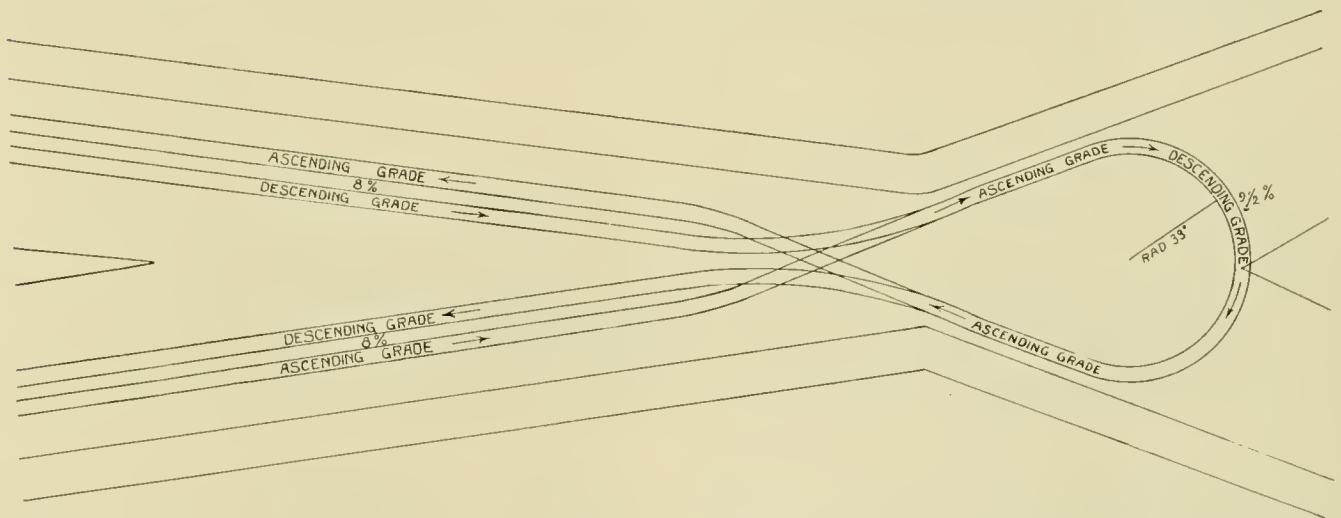

PECULIAR CURVE, CINCINNATI.

pany may also undertake to carry the mail between the Allegheny general office and sub stations of that office.

President John G. Holmes, of the Citizens' Traction Company, has offered to carry letter boxes on cars of his line. His proposal will probably be adopted, as Postmaster O'Donnell is in favor of it.

The prime mover in promoting street car mail service in Pittsburg has been John C. O'Donnell. A consultation between Mr. O'Donnell and J. M. Masten, assistant superintendent of the railway mail service, representing the government, and prominent street railway men of Pittsburg, resulted in the best of feeling upon the subject. Col. G. W. Elkins and C. L. Magee, especially, became warm advocates of the plans broached by the postal authorities, and enlisted others in the cause. As a result of the good feeling between the postal authorities and the traction people, the Duquesne, the Fifth Avenue, the Citizens' and the Birmingham Traction Companies have agreed to carry special delivery messengers free while on duty. Postmaster O'Donnell considers himself greatly indebted to the traction managers for their hearty co-operation and energetic assistance,

TOLEDO, OHIO, ENDORSES T RAIL.

The prediction in the REVIEW that the use of brick filler would now lead to a very general adoption of T rail in places where it has heretofore been denied has already been fulfilled at Toledo, Ohio. The city council have authorized the laying of the 70-pound, seven inch shanghai T rail made by the Illinois Steel Company in connection with the special brick filler manufactured by H. C. Bruner, Pontiac, Ills. The track so laid cannot fail to not only furnish a strong and durable construction, but will please the public and save a great deal of tearing up of streets to get at joints.

FIFTY-THREE passengers on the Suburban Traction Company's, Newark, N. J., Orange line, had a narrow escape from death recently. The car was on the Eagle Rock Division, and while ascending a steep grade at Valley Way the wheels began to slide. On striking the curve a wheel flange broke, and the car upset. Several were bruised and trampled by the excited crowd, but no one was fatally hurt.

## OPERATING EXPENSES OF THE PORTSMOUTH, O., STREET RAILROAD.

BY S. P. BAIRD, SUPERINTENDENT.

I saw an editorial in the September number of the STREET RAILWAY REVIEW on the phenomenally low cost of operating some small electric railroad (not named). I think that the Portsmouth Street Railroad & Light Company operates its road and light plant as well and as economically as any other company operates any plant of equal size.

We have five miles of single track road (with three diamond turn-outs), all of which is of 45-pound steel rail (two miles of girder and three miles of T). We have four curves of 55-foot radius, one of 45-foot radius, and one curve into the power house and car barn of 35-foot radius. Curves are of 76-pound guard rail. Our gauge is standard. Our power house is on the line, very near the center, and in full view of the crossing of our tracks with three steam railroads, also in full view of the center

side the city limits to New Boston, but between May 1 and October 21, 1894, we ran every car through, giving 15-minute service to New Boston, the fair grounds and summer gardens. During seven months our cars run 160 miles on short days and 180 miles on long days. It takes just one hour to make a round trip in summer. During five months of cold weather our cars will average 132 miles each per day. The average mileage of each car during the summer is 170. Thus, 170 miles multiplied by 4, the number of motor cars, equals 680 motor car miles per day; adding the trail car mileage, 680, gives a total of 1,360 car miles per day. The total mileage per day during five winter months is  $132 \times 4 = 528$  miles.

By our time table it will be seen that we have only five crews at work each day. Our men are required to rest one day in six. This we accomplish by having what we call the "day relief crew" which runs the different cars in succession.

Our operating expenses are as follows during cold weather:

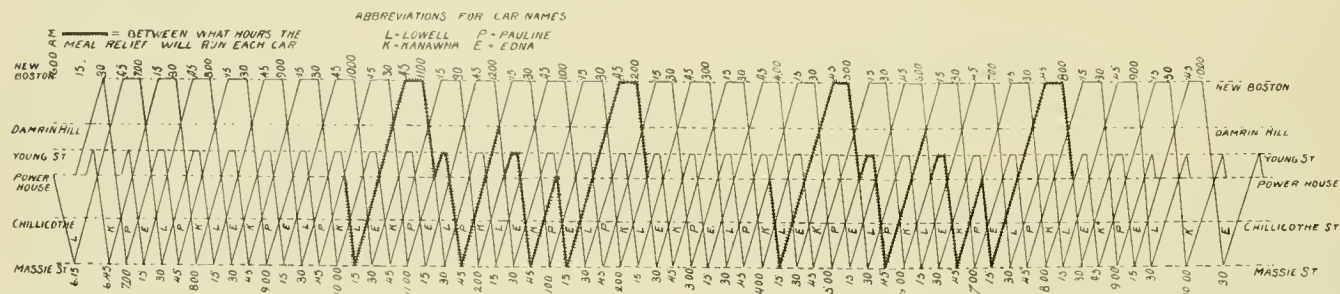

TIME TABLE, PORTSMOUTH, O.

switch. We have in our plant one 80-kilowatt Westing-house generator, direct belted to a 14x14 Ball & Wood engine, running 290 revolutions per minute; three 50-light Thomson-Houston arc machines, driven by means of a countershaft by a 14x14 Buckeye engine; one 100-kilowatt alternator for incandescent lighting, driven by a 14x14 Ball & Wood engine running 310 revolutions, and two 66-inch by 18-foot return tubular boilers; nominal rating, 125 horse power; set with shaking grates.

Our overhead work is of No. 0 hard drawn wire, without any feeders. Our track is double bonded with No. 0 iron with channel pins and is grounded by means of an 8-foot iron rod every third joint. It is cross bonded at each ground rod. Three miles are of span wire construction and two miles of bracket construction. We run our cars fifteen minutes apart from 6 o'clock a. m. to 9:30 p. m., and thirty minutes apart till 10:30 o'clock p. m. During the winter cars run without trailers. During the summer we run one large 8-seat open trailer with each motor. From 6 o'clock a. m. till 10 o'clock p. m. we run a car every fifteen minutes, and from 10 till 12 o'clock p. m. we run one car every thirty minutes.

I show herewith our new winter time table, which is now in force, a copy being posted in each car. It will be observed that we have only a 30-minute service out-

5 motormen,	-	-	-	at	\$1 50	\$7 50
5 conductors,	-	-	-	"	1 00	5 00
1 engineer,	-	-	-	"	1 66	1 66
1 engineer,	-	-	-	"	1 33	1 33
1 fireman	-	-	-	"	1 00	1 00
1 trackman	-	-	-	"	1 00	1 00
2 1/2 tons coal,	-	-	-	"	0 90	2 25
Oil and waste	-	-	-	-	-	0 33
Repairs, 528 car miles,	-	-	-	at	.0025	1 32
Water, at \$200 per annum	-	-	-	-	-	0 55

Total operating expense,	-	-	-	-	\$21 94
Cost, per car mile	-	-	-	-	.0415

Our fixed charges are as follows:

Insurance, at 2 per cent on \$30,000,	-	-	-	\$ 1 66
Interest on bonds, \$70,000,	-	-	-	11 66
Depreciation, at 5 per cent on \$90,000,	-	-	-	12 50
Office expenses, tickets, superintendence, etc.,	-	-	-	16 00
Total fixed charges,	-	-	-	\$41 82
Grand total	-	-	-	63 76
Total cost per car mile	-	-	-	.1207

Our expenses during the summer are the same, with the exception of an additional ton of coal and five additional conductors, making the cost of operating: \$27.84

$\div 680 = \$0.04$  per car mile, if we wish to charge all the expense to the motor cars, or  $\$27.84 \div 1,360 = \$0.02045$  per car mile, if we wish to charge the trail cars with one half the expenses.

We have four motor cars with 16-foot bodies and two 30-horse-power motors on each car, with series-parallel controllers; also seven Brill open trailers. During the county fair this year on the big day we hauled 10,000 people, one motor car with two trailers taking out 350 persons, 130 on one trailer, 127 on the other and 93 on the motor car. Our one 80-kilowatt generator handled this heavy traffic without having the circuit breaker out once, besides handling about 50 horse-power in stationary motors. We accomplished this by carefully explaining the whole system to each motorman and urging the necessity of being saving of power.

Besides our street railroad plant we operate 150 arc lights, the city fire alarm system (50 miles of wire with 40 boxes) and the incandescent light plant, which in all require two men not already enumerated, one horse and trimmer's cart, besides four tons of coal additional each day, with carbons, etc.

We make a systematic inspection of engines each week by means of an indicator; and also keep close tab on coal, oil, repairs, etc.

I think this is an exceptionally fine showing, and feel proud of it.

### WALKER TROLLEY HANGER.

A trolley wire clamp similar in principle to some others recently brought out is the subject of a patent recently issued to I. B. Walker, superintendent of the Sioux City

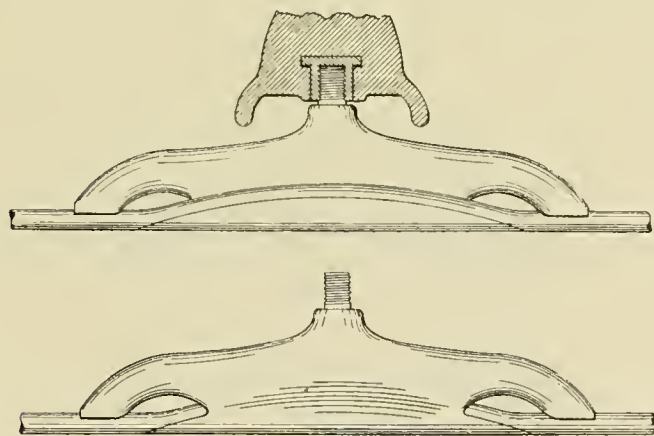

Traction Company. The clamp gives the wire a slight bend as it passes through, and presents a level surface to the trolley wheel. Unlike some employing a similar principle, the clip consists of a single piece.

THE Stirling Company, Chicago, has placed the largest boiler order on record. A contract has been closed for 8,000-horse-power water tube boilers for the West Chicago Street Railroad Company, which will cost nearly \$100,000.

### JACKSON & SHARP NEW SPRINKLER.

The Jackson & Sharp Company, Wilmington, Del., has a new style of sprinkling motor car, one of which has been built for the Delaware County & Philadelphia Electric Railway Company. The car has a new controlling



JACKSON & SHARP SPRINKLER.

device for sprinkling. Perforated pipes, all connected with the same main, are underneath the platform, and are controlled in such a way that the water may be confined between the rails, sprinkled on each side, or in both combinations, at will. The motorman has control of the levers that operate the valves.

### FLINGS AT NEW YORK.

SINCE the adoption of electrical cars in Brooklyn it has been the pleasant jest of the people of that city that, when they felt like taking a trip into the country, they could go over to New York and ride in the horse cars. The holding up of the New York car the other night by highwaymen has probably induced the Brooklyn people to favor some less perilous form of rustic diversion.—Buffalo Courier.

APROPOS of the holding up of street cars, a correspondent suggests that people have no business to ride in the street cars in this town after early candle light, and also that those wealthy persons who go about with watch chains exposed are throwing temptation in the way of our "ruling classes," and should refrain from doing so. There may be something in this.—New York Advertiser.

STREET cars are now held up in this city, officers of the United States navy are assaulted and robbed, gangs of hoodlums roam about at will plundering houses and picking pockets.—New York Commercial Advertiser.

What! in New York? Where are the police?—Chicago Dispatch.

THE installation of electric power has left the Allegheny, Pa., Traction Company with only one horse railway, and on this line only one horse and one car are used.

### THE STANDARD FENDER OF THE TORONTO RAILWAY.

The mention of fenders to a street railway man is liable to be the occasion of a fit of weariness, as it brings to his mind several thousand devices which flit across his mental vision with an indistinctness caused only by the

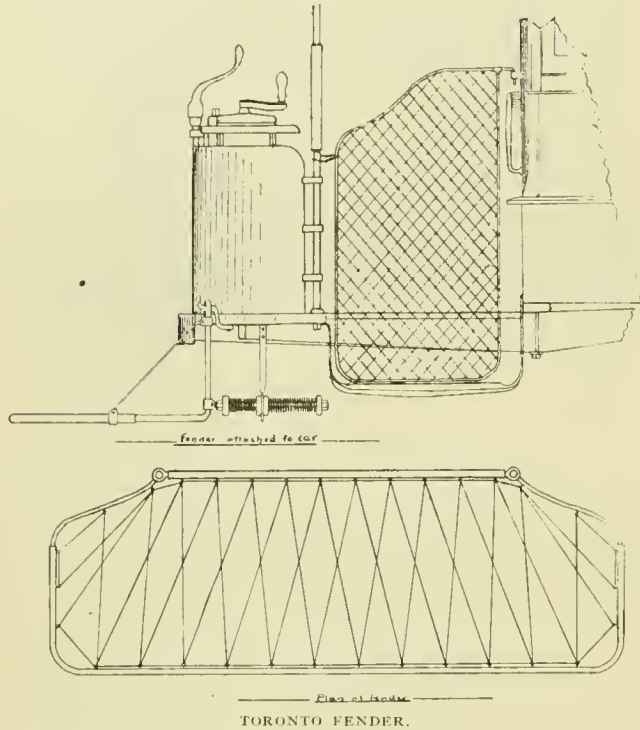

fact that it is impossible for the human mind to remember the details of so many similar appliances. One of the few roads to come to any definite conclusion and actually adopt a certain form of fender, is the Toronto railway. The fender used is shown in the accompanying illustration, for which we are indebted to C. E. A. Carr, of that company. It is similar to the one used at Buffalo.

### EFFECT OF ELECTRIC ROADS.

Steam railroads in the Eastern States are feeling the effect of the inter-urban electric street railway lines, which have cut into their passenger traffic to a large extent. The annual report of the New York, New Haven & Hartford Railroad says: "The construction of electric railroads in the neighborhood of our property continues throughout all its territory. Wherever they seriously reduce the revenue of this property, we shall be compelled to lessen local service in a corresponding degree."

It is reported that the travel between Boston and Malden, on the Boston & Maine road, has fallen off fifty per cent since the parallel electric road was opened. Another road in Massachusetts, which formerly carried about 300 to 400 passengers a day, carries about 75. The Reading Railroad has cut off trains from the Gloucester branch of the Atlantic City Railroad until

there are only six trains each way daily, and four on Sunday, while formerly there were 19 and 13, all on account of the Camden, Gloucester & Woodbury trolley line, which gives excellent service. Two trains in each direction were also cut off the Middletown and Hummelstown and the Williamstown branch. Other roads are cutting off trains in a similar manner. Even in California, especially in Alameda county, the electric lines receive the bulk of the suburban patronage. The Long Island Railroad (steam) is laying additional tracks for rapid transit between Long Island City and Flushing, and will make the fare five cents, instead of twenty and thirty-five cents, the present rate. Approaching electric railway competition is the cause.

### THREE OF A KIND.

Three Brooklyn conductors were hurt the same day in a similar manner at about the same hour. Each was adjusting his trolley pole and was thrown over the tail board, striking the ground with his head. The result was two fractured skulls and a severe scalp wound.

### GAVE BABY A RIDE.

Tin cans, dead dogs, and other articles have been sent down the tracks of cable roads by mischievous small boys, who have let strings down the slot, which, having become entangled with the cable, drag the object clattering down the track. Out on Blue Island avenue the other day, a seven-year-old gamin hit upon the plan of giving his baby sister a nice ride. So he gets a soap box, takes off the cover, and attaches four wires to the



GAVE BABY A RIDE.

bottom of the box. Baby's wagon is complete, and the youngster, who doesn't enjoy tending baby, which is the great cross of many a boy's life, took the box and his sister to the center of the track. Lifting her in, he dangled the four wires down the slot. They caught the cable, and away went the "special." A policeman sent in a call for the patrol wagon, which caught up with the baby and rescued her, after a chase of three blocks.

## THE PASS SYSTEM.

### CONCLUSION.

In the October REVIEW was an article on passes, the thorn in the flesh of all street railway corporations. There is a general movement to cut down passes to the lowest point, which means an issue of free transportation to employes and only to them, when engaged on company business. Employes are passed on their badges, carmen wearing them on their caps, and other employes such as power station men, office men, etc., are all furnished with service badges, which are pinned to the coat. The conductor is compelled to record the number of the badge.

Other roads furnish passes to city officials and newspaper men in coupon book form, 100 coupons to a book. One coupon is detached by the conductor and turned in by him for one fare rung up. These coupon books are similar to that illustrated on page 629 of the October REVIEW, except that pages contain three, four or five coupons. In some cases the name of the holder is stamped on each coupon, which has the signature of the president or other officer, and all have the condition that the book shall be taken up if another besides the person to whom it was issued, attempts to use it.

The Davenport & Rock Island Railway Company, Davenport, Ia., passes employes on cap badges and service badges. Books are issued to members of the city council and newspaper men. They are accounted for in the manner described above.

The Hartford Street Railway Company, Hartford, Conn., uses a form of ticket for conductors, motormen, etc., good for six rides a day. Conductors punch the tickets, each punch having a different die, ring up on register same as cash fare, and record pass number on the back of day card. Foremen of outside laborers are furnished with coupon tickets which they give their men as required. These coupons read, "Employe, good on any line," and are numbered. The day card is arranged for 15 trips. Each trip has two spaces "in" and "out," and the conductor is required to report starting time, car number, passengers, passes, transfers, free tickets, 5 cent tickets, press and letter carrier, and cash fares. The reverse is similarly arranged and shows number of transfers issued on each trip with pass numbers. On the bottom is shown "first transfer to issue to-morrow" and "first transfer issued to-day," the difference between these numbers should show number of transfers issued and is a check on trip reports. A single form of transfer four inches long, has been recently adopted and has given satisfaction to conductors, passengers and company. They are numbered consecutively, and the conductor keeps a stub. On one edge are the names of the different lines. On the other three sides are hours from 5 a. m. to 11 p. m. Each hour has four squares in which are the figures 15, 30, 45 and in the other a. m. or p. m. In the center is the following:

"Issued on line punched. Good for one continuous ride over any other line, if used within 15 minutes of time punched or on first car. In case of controversy about

transfer ticket, passenger agrees to pay fare and to apply within 3 days for redress at the office of the company." As a border to these words is an arrangement of the numbers of the days of the month. The reverse is used for advertising purposes.

The City & Suburban Railway Company, Baltimore, Md., uses the coupon system exclusively for employes and complimentary passes. The books are signed by the president and general manager, and the name of the holder is stamped on each coupon. The tickets are accounted for in the report under "dead heads." A record is kept of all books issued, and the return of covers is requested, which are renewed or not as the company sees fit, motormen and conductors are passed when they have on coat, cap and coat and cap badges. Shopmen are given tickets twice a day by the store-keeper or time keeper, and are good only on date of issue.

The Washington & Georgetown Railroad Company, Washington, D. C., issues complimentary coupon books,

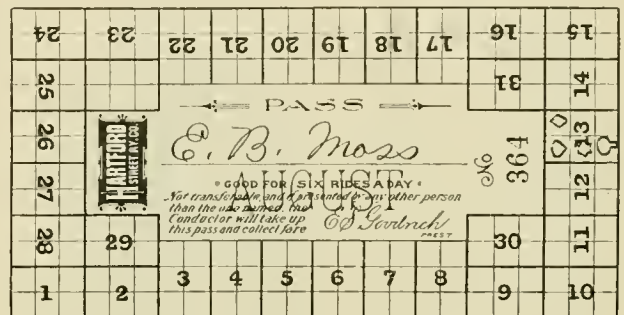

HARTFORD EMPLOYEES' TICKET.

also two checks each day to each employe, good only on date of issue. Conductors detach coupons and punch them with bell punch. Employe's checks are also taken up and punched. They are turned in and counted the same as transfers.

The Detroit Citizens' Street Railway Company, Detroit, Mich., issues coupon books to employes. All other passes were withdrawn December, 1892. The following conditions accompany the book:

"Transfers will not be issued on coupon tickets.

"When coupons in this book are used, or if not used by January 20, 1895, or should you leave the employ of the company, return the book to your superintendent.

"This book is issued for the use of and as an accommodation to the holder only, and coupons therefrom will not be accepted in payment of fare of any other person. A violation of this rule will be deemed sufficient grounds for discharge.

"This book being issued to you gratuitously, it is expected you will comply with the conditions, and use every means to avoid its being lost. In order to make the holder doubly careful, in case a book is lost, he will be required to pay \$2 to his superintendent before another book will be furnished him."

The Duluth Street Railway Company, Duluth, Minn., uses the coupon system for employes and others. It

also has a transfer system similar to that adopted May 1, by the Minneapolis Street Railway Company, and illustrated on page 337 of the June REVIEW. There is practically no trading of transfers.

The Federal Street & Pleasant Valley Passenger Railway Company, Pittsburg, Pa., issues books of 200 employes' tickets to each foreman, with which his account is charged, and credited as the tickets come back through the conductors. There is no check, except the superintendent's personal knowledge of the demands that should be made upon the foreman. There are 400 employes, and the average is 200 tickets a day. From an approved list about 300 tickets a day are issued as required by ordinances and 200 to others. They are issued in books of 100 consecutively numbered from 1 to 100. The treasurer charges his account with 5,000 books, as per the opening and closing numbers of the series, which are issued according to number, so the record shows an unbroken list of numbers, and the stock of books always begins with the next higher number than that shown on the book. When tickets are returned through the conductors they are sorted and credited to the person to whom issued.

The Los Angeles Consolidated Electric Railway Company, Los Angeles, Cal., withdrew all complimentary passes the first of the year. Having only employes' tickets, matters have been simplified very much, and the new plan has been satisfactory. Tickets good for 60 rides are issued to employes, which are punched by conductors who report number on each trip. Conductors and motormen are passed on badges. The employe signs the ticket, agreeing that the company shall not be liable for injury to his person or property.

The Birmingham Railway & Electric Company, Birmingham, Ala., operates an electric line and three separate steam or suburban dummy lines, making four different divisions, each of which is operated as if it were a separate company. On the electric line no complimentary passes are issued except to the mayor, heads of city departments and newspaper men. Every passenger must put money or a ticket in the box. On the dummy lines, which carry freight, complimentary are given to merchants to influence patronage. Conductors of the

steam roads are compelled to report each trip the total number of passengers, number of cash fares; number of tickets; number of passes; and names of all persons riding without money or tickets, officers of the road, or employes going to or from work.

The Toronto Railway Company, Toronto, Can., issues a 52 ride monthly commutation ticket. The purchaser must subscribe to these conditions in the presence of a witness, who must also sign:

"Not good after date of expiration shown on face, even if any strips remain uncanceled, and refund will not be made on such uncanceled strips.

"Not transferable, and must be presented to conductor for each trip, or ordinary fare will be collected for which no refund will be made.

"If lost or stolen will not be replaced by a duplicate ticket under any circumstances.

"Conductor will take up all tickets presented after expiration."

## A STANDARD MONTHLY REPORT.

The engravings which occupy the three following pages are reproduced from the monthly report sheets recommended by H. I. Bettis, at the Atlanta convention, as a standard form. The items correspond with those given in the classification published with Mr. Bettis' report, printed in our October number. The report sheet consists of four pages, of which the report proper occupies three pages, and the first page is left blank, with the exception of a memorandum which comes face up when the report is folded, for convenience in filing.

## FARES ARE REDUCED IN KEOKUK, IA.

Cheap fares have been voluntarily inaugurated in Keokuk, Ia., by the Gate City Electric Street Railway Company, as an inducement to the people to ride. Tickets have been placed on sale, with merchants only, at the rate of eight for twenty-five cents. Persons not provided with these tickets will be required to pay five cents. Unused tickets will be redeemed. The low fare is expected to greatly extend the growing practice of retail merchants giving car tickets to such of their customers as have to ride to reach their places of business.

It is strange how an unusual occurrence is followed by others of a similar character, which usually come in threes. A big fire is frequently the forerunner two others even more damaging, and then there is rest. Horrible casualties go according to this rule, and an example is given of its control in the following. Early in October a woman in San Francisco stole \$5,000 from her husband and eloped with a motorman. On the same day in Beaver Falls, Pa., a motorman stole the pretty wife of a rolling-mill man together with his savings. Two days later a motorman on the Windsor Beach Electric Railway, Rochester, eloped with a farmer's daughter and \$1,350.





## EARNINGS AND EXPENSES.

EARNINGS.		This Year.		Previous Year.		Increase.		Decrease.	
	Cash Fares,								
	Sale of Tickets,								
	Chartered Cars,								
	Freight,								
	Mail,								
	Express,								
	Advertising,								
	Miscellaneous Earnings,								
	<b>Gross Earnings.</b>								
	<b>OPERATING EXPENSES.</b>								
	<b>General Expenses.</b>								
Acct No.	21 Salaries,								
	22 Advertising and Office Expense,								
	23 Insurance,								
	24 Legal,								
	25 Injuries and Damages,								
	26 Contingent,								
	27 Parks,								
	<i>Total,</i>								
	<b>Transportation Expenses.</b>								
	28 Car Service,								
	29 Car House Expense,								
	30 Lubricants and Waste for Cars,								
	31 Electrical Supplies,								
	32 Wrecking,								
	33 Operation Power House,								
	34 Fuel,								
	35 Lubricants and Waste for Power House,								
	36 Water,								
	37 Hired Power,								
	<i>Total,</i>								
	<b>Maintenance of Way and Buildings.</b>								
	38 Repairs Roadbed and Track,								
	39 Removing Snow and Ice,								
	40 Renewals of Rails,								
	41 Renewals of Ties,								
	42 Repairs and Renewals Paving,								
	43 Repairs and Renewals Supplementary Wire,								
	44 Repairs Buildings and Structures,								
	45 Repairs Overhead Line,								
	<i>Total,</i>								
	<b>Maintenance of Equipment.</b>								
	46 Repairs Cars,								
	47 Repairs Armatures and Fields,								
	48 Repairs all other Electrical Apparatus,								
	49 Repairs Steam Plant,								
	50 Repairs Dynamos and Switchboard,								
	51 Repairs Tools and Machinery,								
	52 Miscellaneous Expense,								
	<i>Total,</i>								
	<b>Total Operating Expenses</b>								
	<b>Net Earnings.</b>								
	<b>Fixed Charges.</b>								
	Interest Accrued,								
	Taxes,								
	<b>Total Fixed Charges.</b>								
	<b>Surplus Earnings.</b>								
	<b>Deficit.</b>								

BALANCE SHEET.

<b>RESOURCES.</b>					
<b>CONSTRUCTION AND EQUIPMENT.</b>					
Superintendence.					
Engineering.					
Right of Way					
Buildings and Structures.					
Track and Roadway.					
Overhead Line.					
Car.					
Snow Plow and Sweepers.					
Power Station.					
Tools and Machinery.					
Improvements and Betterments.					
Interest and Discount.					
Total Construction and Equipment					
<b>INVESTMENTS.</b>					
Total Investments.					
<b>CASH ASSETS.</b>					
Cash.					
Accounts Receivable.					
Notes Receivable.					
Supplies on Hand.					
Total Cash Assets					
<b>SUNDRY ITEMS.</b>					
Treasury Stock.					
Total Sundry Items.					
Total Resources.					
<b>LIABILITIES.</b>					
<b>CAPITAL STOCK.</b>					
The Paterson, Passaic & Rutherford Electric R'y Co..					
Total Capital Stock.					
<b>FUNDED DEBT.</b>					
Total Funded Debt.					
<b>CURRENT LIABILITIES.</b>					
Accounts Payable.					
Notes Payable.					
Total Current Liabilities.					
<b>SUNDRY ITEMS.</b>					
Accrued Interest					
Accrued Taxes.					
Total Sundry Items					
<b>PROFIT AND LOSS.</b>					
Total Liabilities.					



### ADVERTISING POINTS OF INTEREST.

The REVIEW has always advocated the advertising of points of interest on street railway lines by means of folders similar to the method that has grown so familiar on account of its general use by steam roads. One of the handsomest received by the REVIEW is an eight page folder of the Niagara Falls, Park & River Railway, Niagara Falls, Can. The inside eight pages are lithographed in several colors, showing views of many interesting points and of the road in operation, which are here reproduced, except as to coloring. From a scenic standpoint this line is an ideal road, but other lines have as many points of interest which should be made to create traffic. This folder describes the various places to be seen, giving

Armstrong, the well-known electrical expert of Chicago, to work out the technical details. The outfit as now arranged consists of an ordinary 1,000-volt alternator driven by a high speed engine on the car. This alternator furnishes current to a step-up transformer which gives a voltage of from 5,000 to 40,000 volts. One pole of the transformer is grounded and the other is connected to wire brushes which are fixed at such a distance above the track that they strike the tops of the weeds as the car moves along. The action of the apparatus is remarkable. The weeds having the most sap in them tumble over at once, and in time dry up, showing them to be killed by the first shock. The principal cause for this action is that the current heats the sap in the weeds to such an extent that they are literally cooked. Weeds

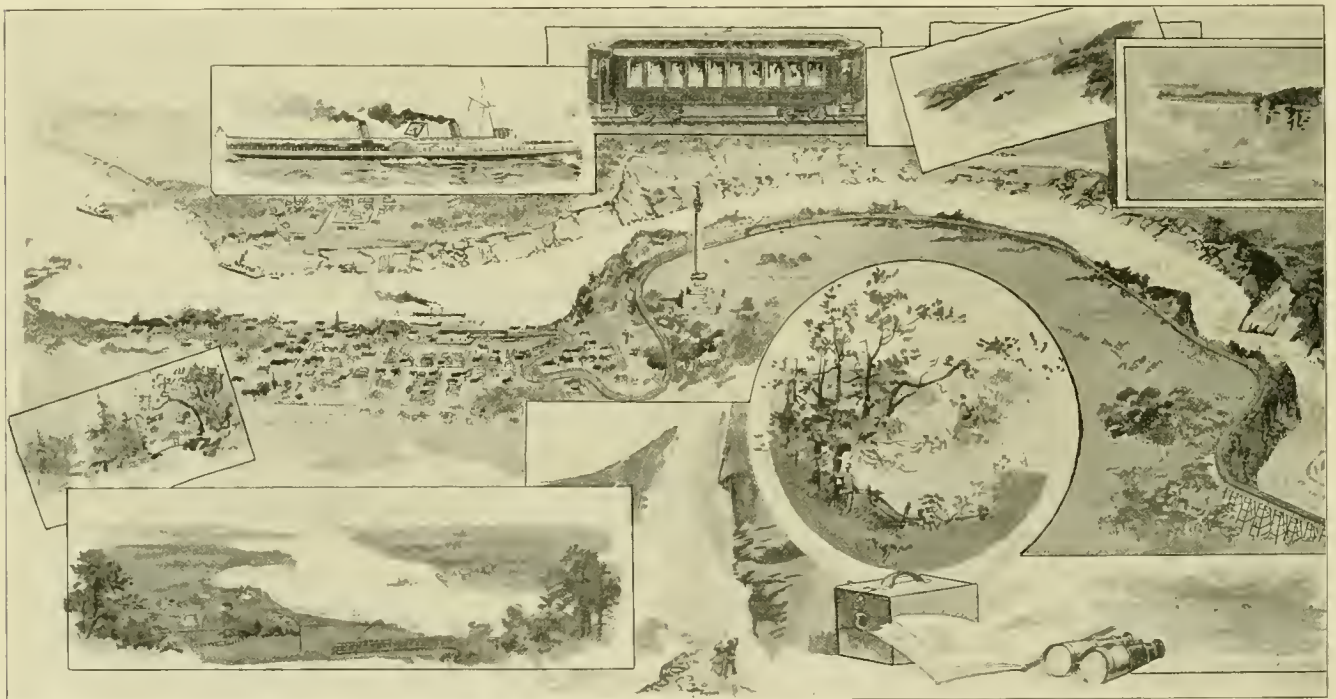

ADVERTISING POINTS OF INTEREST.

prices where fees are charged, and other information, which shows the people of the country that the famous "Niagara Falls hackman" need be no longer feared.

### KILLING WEEDS BY ELECTRICITY.

Although managers are just now more interested in the prospect of bucking snow in the immediate future than in the possibility of killing weeds by electricity in the remote future, it will not be out of place here to briefly recount some of the work done in this direction along some of the southern divisions of the Illinois Central, as this method of weed killing may some day be used on the interurban lines which are multiplying throughout the country. The weed killer used on the Illinois Central was originally thought of by A. A. Sharp, superintendent of the Yazoo & Mississippi Valley division, who secured patents on it, and employed C. G.

pulled up immediately after the car has been along are too hot to handle, even at the roots. The arcing between brushes and weeds as the car goes along also destroys some. About 16,000 volts has been found the best pressure for ordinary work. It can be done with as low a voltage as 6,000, but not as well, while over 16,000 is more than is usually necessary. Different kinds of vegetation require different voltages. The car used last season had brushes to the width of the ties and required 80 kilowatts when running six miles an hour. The faster the work is done the greater the energy required, as the weeds fall over when struck, and the faster the car goes the more are struck in a given time. A car is now being fitted up with a 200-kilowatt alternator and transformer, so that lack of power will be no hindrance to rapid work in the future. In some places the keeping of the road-bed clear of weeds by hand is an important item, amount-

ing to \$60 per mile of track per year. The electric method certainly ought to cost less than this, as it absolutely kills what vegetation it strikes, so that it can not come up again from the root. After the first few times, therefore, it is not necessary to go over the track very often. The Great Northern Railroad will experiment with one next season. If the plan is tried on electric interurbans, a flat car having a motor generator and step-up transformer run from the trolley wire could be fitted up without a great deal of outlay. The capacity of the apparatus required depends on the speed it is proposed to run at over the road, and if it was practicable to do the work slowly the motor and generator could be small.

### TROLLEY CAR SPEED.

How to calculate the speed of a trolley car is an interesting problem to anyone in the business, who happens to be riding faster or slower than he is accustomed. It also has a fascination to the passenger with an enquiring mind. Various ways have been suggested, but the simplest is to note the number of feet the car goes a minute and divide by 88, which will give you the number of miles an hour, or rate of speed. A car moving at the rate of one mile an hour will pass over 88 feet a minute. A speed of 176 feet a minute is at the rate of 2 miles an hour; 352 feet, 4 miles; 528 feet, 6 miles; 704

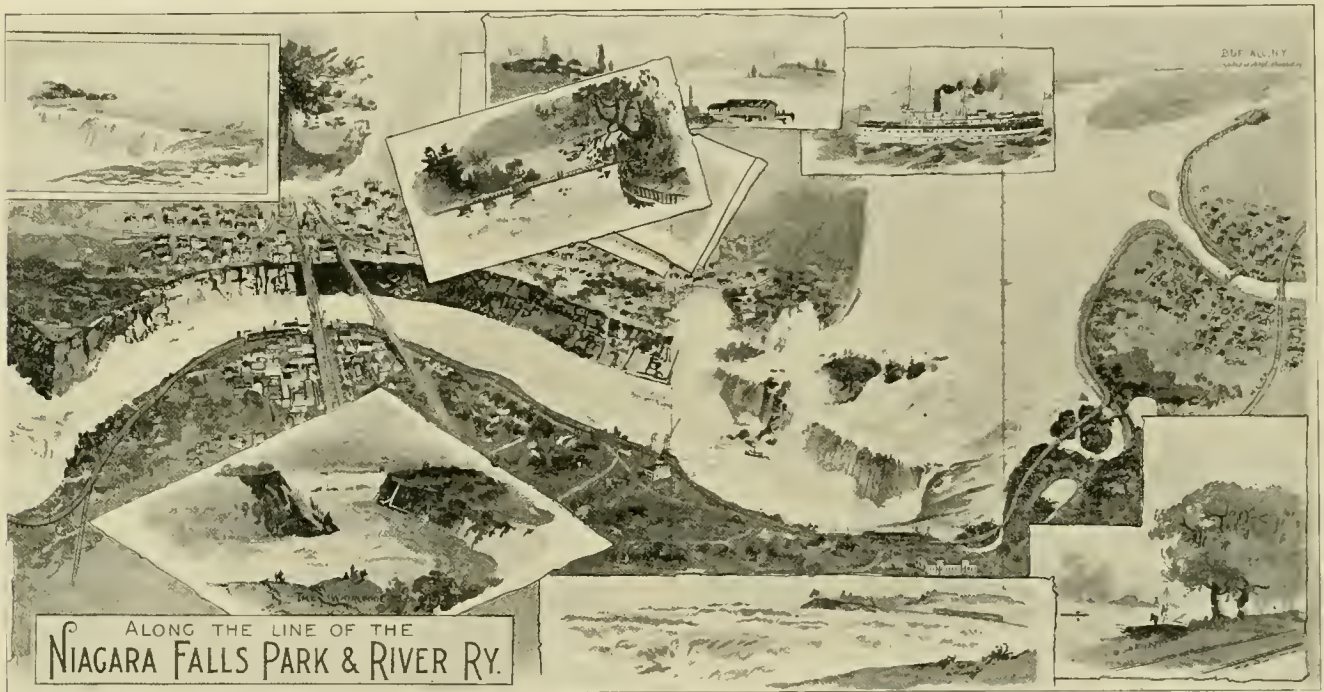

ADVERTISING POINTS OF INTEREST.

### HAS GONE TO KANSAS CITY.

In the Woodland avenue power house of the Kansas City Cable Railway Company has been installed an engine which has been seen by more people than any engine in the world. On November 1, 1893, this engine finished its work in Machinery Hall, at the World's Fair. It is known as the Reynold's-Corliss type, and is capable of developing 2,000 horse-power. The foundations are 42 feet long. The engine weighs 150 tons.

Several changes have been made in the engine to adapt it to its new work. It will drive all the ropes of the Ninth street system, except Summit street, being nearly 100,000 feet of cable. The old engines will be coupled together for use interchangeably with the new one. New cars will be put on the Ninth street incline, and plans have been prepared for a tunnel from Washington street toward the depot. Ten freight cars were necessary to transport the engine. The balance wheel weighs 75 tons.

feet, 8 miles; 880 feet, 10 miles; 1,320 feet, 15 miles; 1,760 feet, 20 miles; 2,200 feet, 25 miles; 2,640 feet, 30 miles; 3,520 feet, 40 miles; 4,400 feet, 50 miles; 5,280 feet, 60 miles. If poles are set regularly at equal distances, it is easy to calculate the distance the car goes in a given time.

A rather complicated method is going the rounds of the press, which is based upon the purring sound caused by the meshing of the gear and pinion teeth. In order to calculate by this plan it is necessary to carry along a tuning fork or a seven-octave piano. If the tone is the same pitch as "middle C," which makes 264 vibrations a second, the teeth are meshing at the rate of 264 a second. If the number of teeth on the gear is known, together with the diameter of the car wheel, the rate of speed can be ascertained.

The number of 30-foot rail lengths passed over in twenty seconds will give the speed in miles per hour, approximately. Here is certainly given enough information for a satisfactory determining of car speed.

WALKER'S BLOCK SIGNAL AT SIOUX CITY.

Among the numerous other new devices that the ingenuity of Superintendent I. B. Walker of the Sioux City Traction Company has brought before the street railway world is a block signal recently put in operation at a bridge on one of his lines. The bridge is single track

light to cars coming the opposite direction. When the car has crossed the bridge and again enters the double track another contact hanger is passed which sends another current bringing the solenoid to a central position and puts the signal lights out. Thus, unless the signal shows a red light the track is clear. It is a very simple arrangement and has the advantage of being cut out except when a car is on the single track.

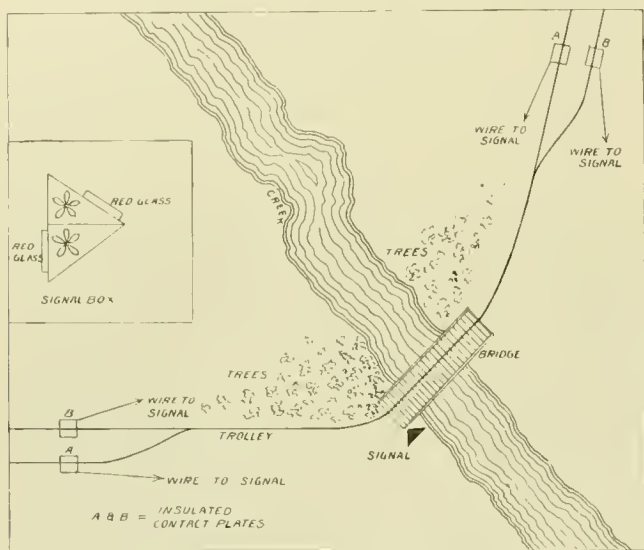

WALKER BLOCK SIGNAL.

while there is a double track on each side of it. There is also a turn near the bridge and trees obstruct the view so that a motorman coming onto the bridge can not see whether there is another car approaching on the single track and there is great danger of a collision unless the conductor walks ahead for some distance. The arrangement of bridge and tracks can be seen from a glance at

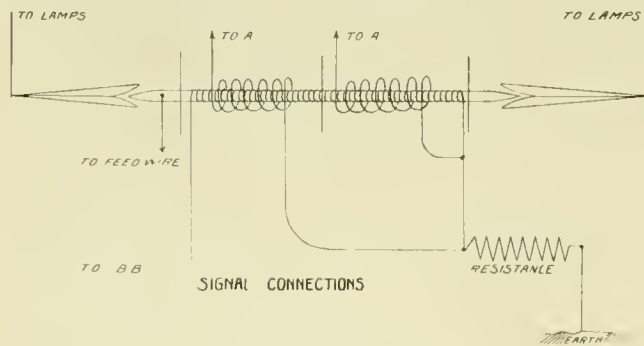

WALKER BLOCK SIGNAL.

the engraving. The signal box is on one corner of the bridge where it can be seen from both ends of the single track. On the double track near each switch is a special trolley wire hanger having an insulated contact plate arranged so that when a trolley wheel passes along it makes a contact which sends a momentary current over the wire to the signal box. At the signal box is a magnet wound with three coils as herewith shown. When a car passes this hanger a current is sent through the magnet so that the plunger in the coil is brought over to make contact with the lamp circuit which displays a red

TREATMENT FOR ELECTRIC SHOCKS.

The London Lancet gives some directions for the treatment of persons severely shocked that may be of a little use to men on electric railway work, although shocks from 500-volt circuits will rarely be as severe as those implied in the rules. The rules will, however, give new men a general idea of some of the precautions to be employed. One of the principal difficulties is in getting a man off a live wire, and this operation is well covered by the instructions. The treatment after this is done is much the same as for drowning.

The rules are:

First—Break the circuit at once if there be any interrupter close at hand and you know how to use it. If not, lose no time, but proceed to rule 2.

Second—Do not touch the man's body with your bare hands, but if India rubber gloves are not at hand pull him off the cable by his coat tail, or fold your coat or some such dry article into two or three thicknesses, and, using this as a pad to take hold of the body, pull it away from the circuit and resort to rule 5.

Third—If unable to get him off, raise with covered hands that part of the body which is touching the earth, or one of the poles of circuit; this will break the circuit, and it will usually be thus possible to get him easily away, and, if so, proceed to rule 5.

Fourth—If still unsuccessful, make another pad, and, placing it between the ground and that part of the body in contact with the ground, continue your efforts to detach him.

Fifth—Having pulled him away from the cable, free his neck from clothing, and treat the case as one of drowning, one method being as follows:

Sixth—Open his mouth, and taking hold of the front part of the tongue with your fingers (covered with a handkerchief, if you have one), draw the tongue forward, and gradually let it go back sixteen times a minute. Be sure that the root of the tongue is acted upon and drawn forward. If the teeth are clenched and you cannot get them apart with your fingers, gently separate them with the handle of a pocket knife or by a small piece of wood, cork, etc.

Seventh—Resist the efforts of the bystanders to pour stimulants down his throat until a medical man arrives and "takes over" the case.

A DAM forty feet high will be built to furnish water power for the new electric railroad, which is to run between Batavia and Lakeside, N. Y.



**ELECTRIC RAILWAY FOR THE SANDWICH ISLANDS.**

Sometime ago the REVIEW published a detailed description of the street railway at Honolulu, together with quite a collection of views of that interesting city, taken expressly for the article. A correspondent for this magazine, now en route to the Old World, sends the interesting information that when in Honolulu a few weeks since he met T. Hofman, of San Jose, Cal., who is there projecting an extensive system of electric lines.

The many points of far-famed interest in which the island abounds, and the, at present, exceedingly poor facilities for visitors to reach these attractions, opens up a promising field of usefulness for the electric car. In the same connection it is intended to convert the present horse car system of Honolulu to electric.

H. Pain, a successful manager and a most genial gentleman, is managing director of the Hawaiian street railway, and we present his portrait herewith. In the group of illustrations will be found a glimpse of the company's car house, and a home-made car, "No. 25," which was made in the company's own shop, entirely of native material and with native labor. Most of the 25 cars, however, were built in San Francisco. There are 12 miles of track, on which 80 employes and 190 horses are used, and last year the road transported one and one-half millions



H. PAIN.

of passengers. The line was opened in 1889. The view of the former residence of the ex-queen shows the native foliage, and was taken when that much talked of ruler was in power. She is now spoken of as Mrs. Dominis.

Another cut shows the rocky road now traveled by tourists and others, but which is a part of the proposed route of the electric railway, the construction of which will form a most interesting piece of electrical engineering. In this picture the road in the foreground may be faintly traced at the right as it winds far up the mountain side.

CONDUCTORS and motormen of the Quincy, Ill., line are said to resemble each other so closely, that passengers meeting cars think they have lost the company's representatives with whom they started.



ABSURDITY OF THE RECENT RULES ADOPTED BY  
THE UNDERWRITERS' INTERNATIONAL ELEC-  
TRIC ASSOCIATION, COVERING THE USE  
OF 500-VOLT FUSES.

BY W. E. HARRINGTON, CAMDEN HORSE RAILROAD.

The writer recently received a pamphlet from the "Board of Fire Underwriters" containing a description of a series of tests to determine the safe length of fuses of different capacities in amperes for 500-volt circuits. The deductions from the above tests were formulated as rules of practice for users of 500-volt circuits. The tests were conducted by a committee representative of the several "Boards of Fire Underwriters" throughout the United States. A copy of the tests and tabulated results are attached as an appendix to this paper. A careful perusal of the appendix will show that great care was observed by those conducting the tests in question, and if the practical use of fuses, particularly the conditions under which a fuse "blows," were in any wise similar to the requirements as prescribed, then the tests and results would not be open to criticism. Unfortunately, the "blowing" of a fuse is an accident, and an accident is an occurrence over which we have no control. It is just as likely for a "short circuit" to occur on a circuit containing a ten ampere fuse, as it is to have a condition of circuit wherein just the ten amperes (the minimum current required to "blow" the fuse) will flow. The sole animus for making the tests was to determine the dimensions of fuse blocks that would overcome the arcing phenomena attendant upon the "blowing" of 500-volt fuses in lower voltage fuse blocks, the only type heretofore available for use. As will be noticed, the tabulated results state specifically the safe lengths in inches for different capacity fuses, ranging in size from 10 amperes to 100 amperes in 10 ampere steps. Further, the results as obtained, were based on the one condition that the current in amperes flowing at the time of fusion was the minimum current causing fusion. In addition to the foregoing, attention is called to the better protection afforded by using a bridge.

The writer intends to demonstrate, by both the results of practice and specially conducted tests, the absurdity of promulgating the results of such incomplete tests as the basis for formulating rules in the matter of the protection of 500-volt circuits. Since the arc accompanying the "blowing" of a fuse is the thing to be avoided, or rather mitigated, tests were conducted with a view of determining the properties of an arc under the same conditions as regards length, with different currents. Pieces of No. 8 copper wire were cut and mounted horizontally, an inch apart longitudinally. An arc was established between these terminals with ten amperes. Note was taken of the ohmic resistance. Next, twenty amperes were caused to flow, and again note was taken of the ohmic resistance. This process was repeated for currents in ten ampere steps to fifty amperes, in each instance note being taken of the ohmic resistance. Curve marked Fig. 1 shows

graphically the relation borne by current flowing through the arcing interval of one inch, and its corresponding ohmic resistance. It will be noticed, and to this fact the writer would draw particular attention, that the ohmic resistance drops off very rapidly as the current increases. The results, as obtained, show beyond a peradventure of a doubt, that under conditions of a short circuit the ohmic resistance of the arc is negligible. The decrease in resistance in the arc as the current increases is unquestionably due to the greater volume and therefore greater cross section of the gas formed, as it does not seem possible the specific ohmic resistance of the gases should materially vary. It is interesting here to make note of the fact that the slightest movement of the air in the vicinity of the arc caused a variation in the resistance. The foregoing

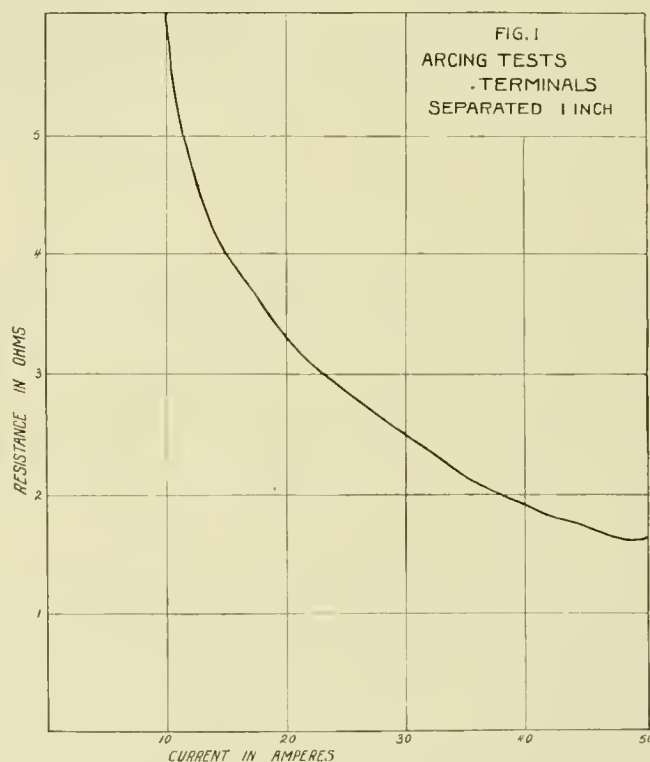

establishes positively that if a given length break in a fuse block protects for one maximum current, it may not for greater currents. The entire and sole cause of the protection afforded in a break caused by fusion is due directly to the resistance interposed in the circuit by such fusion, and the tests show that such resistance becomes less as the current grows greater. In order to read the almost instantaneous currents due to short circuits, a magnetic circuit breaker of the "C-S" automatic type was taken and calibrated to open on different adjustments, ranging from 38 amperes to 400 amperes. Different lengths of No. 30 copper wire were tested in series with the "C-S" circuit breaker directly across the 500-volt bus bars of the switch-board of the Camden Horse Railroad Company, thus making an absolute "short circuit." In every instance, for each length of the No. 30 copper wire, ranging from one inch to eight



inches, with and without bridge, the "C-S" circuit breaker set for 400 amperes was opened upon making a short circuit.

Here is an exceedingly interesting state of affairs. A copper wire which will fuse upon the passage of about two amperes, allowing 400 amperes to pass upon a short circuit, and then not protecting the circuit in which it was placed, for the magnetic circuit breaker opening was the immediate cause of the breaking of the arc established by the "blowing" of the fuse. This latter deduction is deceiving. As a No. 30 copper wire will really only permit the passage of 40 amperes upon a short circuit, the question naturally arises: How did 400 amperes come to flow? The answer is readily given. This excessive current flows not through the fuse, but through the arc maintained at the expense of the terminals, the fuse simply playing the role of establishing an arc. In a long series of experiments covering another field of research, but wherein almost innumerable fuses of different capacities and lengths were employed in making 500-volt short circuits, in no instance was the circuit protected by the fuse but by the opening of the main magnetic switch-board circuit breakers. In many instances fuses made of No. 22 copper wire, 6 inches long, have opened circuit breakers requiring 800 amperes to open.

There exists a popular misconception of the action of bridges. A bridge is an additional protection, as it increases the length of the arc, other dimensions remaining the same, but as we approach short circuits the little additional length due to the bridge does not figure, and the repeated tests made by the writer emphatically confirm this fact. The ideal and not impracticable fuse block for the protection of 500-volt circuits is not one with a great breaking distance, neither one with a bridge, but one with protected terminals. This type permits the blowing of the fuse only, without the attendant arcing, always vicious and destructive of the terminals.

In conclusion, a 500-volt circuit is not protected by the forms of cut-outs recommended by the International Electric Association. Further, it is absolutely dangerous to adopt such precaution, as the continued arcing which would ensue in event of a short circuit would easily ignite any inflammable material in the immediate vicinity. This latter claim is confirmed by the frequent instances of car and car house fires.

#### APPENDIX.

UNDERWRITERS' INTERNATIONAL ELECTRIC ASSOCIATION—Secretary's Office, 55 Kilby Street—Second Report of the Electrical Committee.

BOSTON, MASS., June 15, 1894.

LENGTHS OF FUSES.—The following result of tests to determine the length of arcs maintained on 500-volt circuits when carrying currents ranging in amount from 10 to 100 amperes, will be interesting, and give data which will enable inspectors to judge of the length of fuse necessary for various amperages in such circuits.

GENERAL DESCRIPTION.—A special slate fuse block one inch thick, three inches wide and twelve inches long

was used, with heavy composition terminals, one of which was fastened to a brass strap embracing the block, making it possible to adjust the length between terminals at will. A water resistance for regulating the current was connected in series with the fuse block. Fuses of various sizes were placed in the block in a vertical position, and a steady current maintained till they melted. Beginning with 10 amperes, observations were taken at intervals of 10 up to 100 amperes.

METHOD FOLLOWED IN MAKING TESTS.—The test throughout was conducted in the following manner: At each interval of ten amperes, the terminals were at first placed close enough together to establish an arc when the fuse melted. The distance between them was then increased a quarter of an inch, and if arcing again took place the operation was repeated until no arc was formed. When this point was reached, two more fuses were melted under the same amount of current, and if no arcing occurred in the three successive trials it was considered a safe length for fuses whose melting point corresponds to the current used. At every point the largest fuse was used that could be melted within about five minutes; for it was found that when a fuse melted quickly, no arc occurred at distances at which heavier fuses readily maintained one. Whenever even a momentary arc was formed that distance was regarded as unsafe, and longer ones taken till no arc occurred on three trials.

COVERED FUSES.—Tests were made to ascertain what effect enclosing the fuse in a box had on the arcing distance. It was found that covered fuses should have at least a quarter of an inch more length between terminals, while a half inch would be more satisfactory.

EFFECT OF BRIDGE BETWEEN TERMINALS.—The terminals were moved to within  $1\frac{1}{2}$  inches of each other, and an asbestos-covered bridge, the width of the fuse block and  $2\frac{1}{2}$  inches high, placed between them. With 100 amperes there was no tendency to arc; whereas, with a straight fuse, 4 inches was the minimum length at which no arcing occurred. Instead of nearly all the fuse melting, as was the case with straight fuses, only about an inch or less dropped out. By employing a bridge of proper material, it is thus possible to use a much shorter fuse block. Such a block is in every respect as safe as the ordinary form, and obviates the vicious fusing that occurs with straight fuses on 500 volt currents.

EFFECT OF EXCESSIVE CURRENT ON SMALL FUSES.—In order to determine the effect of large currents on small fuses, a current of 150 amperes was passed through a fuse rated to melt at 10 amperes. The length of the fuse on the first trial was one-half inch, the safe length determined by the foregoing experiments. This length was increased by one-half inch steps up to one and one-half inches, and the effect noticed at each length. In no case was a continuous arc maintained, although with the one-half inch fuse the flash was quite bad, burning the terminals slightly. The same results were obtained on all of the longer lengths. This tends to show that on circuits of a large capacity the only safe fuse is either one provided with a suitable bridge or one of excessive length.

DATA.—The following data give the maximum length between terminals at which arcing occurs, the minimum lengths at which no arcing was observed, and the safe lengths on 500 volt circuits for fuses whose melting points are identical with the various current strengths designated:

Ampere.	Maximum Length at which arcing occurred	Minimum Length at which no arc was observed.	Safe Lengths.
10	$\frac{1}{4}$ inch	$\frac{1}{2}$ inch	1 inch.
20	$\frac{1}{2}$ "	$\frac{3}{4}$ "	2 "
30	2 "	2 "	2 $\frac{3}{4}$ "
40	2 "	2 $\frac{1}{4}$ "	3 $\frac{5}{8}$ "
50	2 $\frac{1}{4}$ "	2 $\frac{1}{2}$ "	3 $\frac{1}{2}$ "
60	3 "	3 $\frac{1}{4}$ "	3 $\frac{3}{4}$ "
70	3 "	3 $\frac{1}{4}$ "	4 "
80	3 $\frac{1}{4}$ "	3 $\frac{1}{2}$ "	4 $\frac{1}{2}$ "
90	3 $\frac{1}{2}$ "	3 $\frac{3}{4}$ "	4 $\frac{3}{8}$ "
100	3 $\frac{3}{4}$ "	4 "	4 $\frac{1}{2}$ "

### NEW WATER TUBE BOILER.

A new vertical high pressure water tube boiler has been designed and manufactured by the Atlas Engine Works, Indianapolis, Ind. It is mounted in an upright position within a casing lined with fire brick. The lower

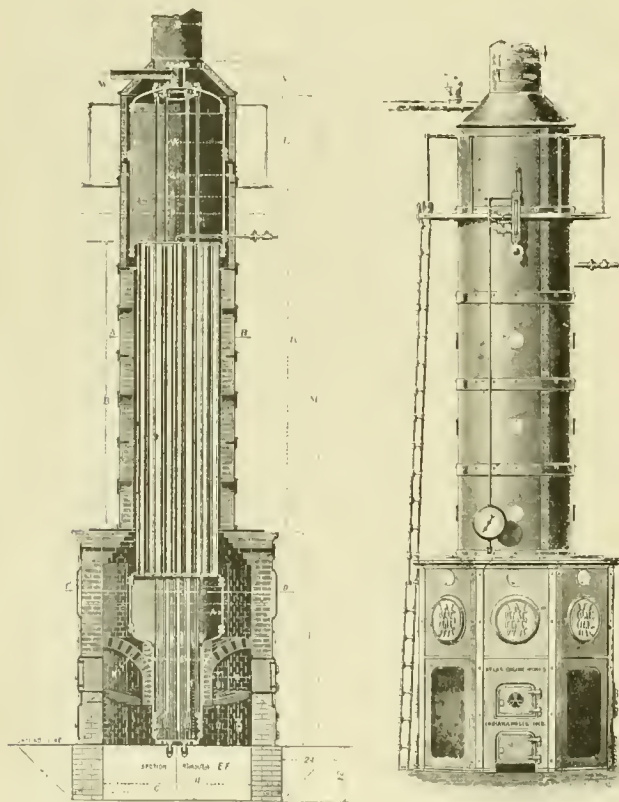

NEW VERTICAL WATER TUBE BOILERS.

part is a drum of inverted bottle form, the central portion of less diameter extending below the grate, and is enclosed in fire brick, while the main portion is held at a considerable height above the fire. Mid height of the boiler is a set of vertical tubes. The upper part is a drum in which a liberal surface is presented for the disengagement of the steam from the water.

The manufacturers say the descent of the water through the central tubes is promoted by a set of telescoping tubes

extending the water tubes to near the bottom of the water leg, which may be slipped up into the water tubes out of the way whenever necessary to enter the water leg for cleaning or repairs. It is claimed that when extended downward to be thoroughly efficient these tubes protect the central set of tubes from being effected by the large volume of steam generated in the exterior portion of the lower drum which rises through the series of tubes above, insuring an active upward current of steam and water through those tubes. It is said that further steam is generated in the tubes by the circulation of the gaseous products of combustion through the spaces between them.

The steam and water thus rising, separate in the upper drum, and the steam is carried away for use, while the water descends through the central tubes of the series. It is claimed that only a small quantity of steam is generated in the central tubes, which is carried down by the central current, and moving outward in the lower portion rises and contributes to the vigor of the strong rising columns in the tubes near the periphery of the series.

Between the central portion of the boiler and the annular furnace is a non-conducting protection which prevents the fire from being too much cooled along the edge, the makers say, and allows all portions of the grate surface to be about equally efficient, while the fire brick also preserves that portion of the boiler from being overheated in any exigency. The annular grate is slightly inclined inward, and the annular furnace is fed, cleaned, etc., through doors in the outward casing. A perforated protection of fire brick is extended over the fire. The masonry wall is extended inward at mid-height of the tubes, so that it comes nearly in contact with the outermost tubes. The gaseous products of combustion are deflected inward, circulate around the tubes, and are finally carried out through a central stack at the top.

The Dewey Electric Signal Company, 26 and 28 Cortlandt street, New York, has furnished an equipment of electric push buttons for the cars of the Niagara Falls & Suspension Bridge Street Railway Company. The push buttons operate the signal bells and the alarm gong. Those operating the signals are placed at different points throughout the inside of the car in convenient reach of the passengers. Those operating the gong are placed in the floor of the car at each end where the motorman can press them with his foot. As long as he keeps his foot upon the button the gong continues ringing, thus doing away with the continual up and down movement of the foot and enabling him to concentrate his attention upon the controller and brake. Moreover only one gong is required. The officers of the Dewey Electric Signal Company are Arthur M. Dodge, president; F. G. Ingersoll, vice-president and general manager, and Geo. B. Hollister, secretary and treasurer. The foregoing and J. F. Tams, Charles H. Duell and Edward B. Lyman compose the board of directors.

## TIME TABLES AND TRAIN SCHEDULES.

### PART IV.

The time cards of the Cincinnati Street Railway Company are all made out by John Harris, superintendent. We illustrate the one in use on the Eighth Street Electric line. Sixteen cars are run morning and evening and 12 cars during the day. The card shows extras, Nos. 13, 14, 15 and 16, which make three trips in the morning and four trips in the evening, to relieve regular cars dur-

ing heavy travel. The evening extras leave at 4:05, 4:15, 4:23, 4:33, p. m. Cars are run under 2, 3 and 4 minutes headway.

The Consolidated Traction Company, Newark, N. J., uses the form shown herewith on its New York division.

The Metropolitan Street Railway Company, New York City, in making up time tables and computing headway, is governed by the amount and direction of travel at different times of the day, based upon reports of travel by hours covering the day and taking several days in succession.

## TIME CARD.—Cincinnati Street Railway Co.,

*Eighth Street*

	1	2	13	3	4	5	14	6	7	15	8	9	10	16	11	12
1	5:30	5:34		5:37	5:41	5:44		5:48	5:51		5:55	5:58	6:02		6:05	6:09
2	6:12	6:15	6:17	6:20	6:23	6:25	6:27	6:30	6:33	6:35	6:37	6:40	6:43	6:45	6:48	6:51
3	6:54	6:57	6:59	7:02	7:05	7:07	7:09	7:12	7:15	7:17	7:19	7:22	7:25	7:27	7:30	7:33
4	7:36	7:39	7:41	7:44	7:47	7:49	7:51	7:54	7:57	7:59	8:01	8:04	8:07	8:09	8:12	8:15
5	8:18	8:22		8:25	8:29	8:32		8:36	8:39		8:43	8:46	8:50		8:53	8:57
6	9:00	9:04		9:07	9:11	9:14		9:18	9:21		9:25	9:28	9:32		9:35	9:39
7	9:42	9:46		9:49	9:53	9:56		10:00	10:03		10:07	10:10	10:14		10:17	10:21
8	10:24	10:28		10:31	10:35	10:38		10:42	10:45		10:49	10:52	10:56		10:59	11:03
9	11:06	11:10		11:13	11:17	11:20		11:24	11:27		11:31	11:34	11:30		11:41	11:45
10	11:48	11:52		11:55	11:59	12:02		12:06	12:09		12:13	12:16	12:20		12:23	12:27

## CONSOLIDATED TRACTION CO. TIME TABLE NEW YORK DIVISION LEAVING NEWARK

NO. TRIPS	COND'R.													M'T'R'M'N	NO. TRIPS	
1		5:30	7:20	9:10		12-	1:50	3:40								1
2						11-	12:50			6:20	8:15	10-	11:45			2
3		5:40	7:30	9:20				3:50	5:40	7:30						3
4		5:50	7:40	9:30		12:20	2:10	4-								4
5						11:10	1-			6:40	8:30	10:15	12-			5
6		6-	7:50	9:40				4:10	6-	7:50						6
7						11:20				7-	8:45	10:30	12:15			7
8		6:10	8-	9:50		12:40	2:30	4:20								8
9						11:30	1:20			7:10	9-	10:45				9
10						11:40				5:30	7:20	9:15	11-			10
11		6:20	8:10	10-	11:50			2:40	4:30							11
12		6:30	8:20	10:10				2:50	4:40	6:30						12
13		6:40	8:30	10:20			1:10	3-	4:50							13
14						12:10	2-			5:50	7:40	9:30	11:15			14
15		6:50	8:40	10:30				3:10	5-	6:50						15
16		7-	8:50	10:40			1:30	3:20	5:10							16
17						12:30	2:20			6:10	8-	9:45	11:30			17
18		7:10	9-	10:50			1:40	3:30	5:20							18



# REQUEST ARTICLES.

Articles under this head are prepared at the request of street railway men who have expressed desires to see articles compiled on the subjects taken up.

## ARE GUARD WIRES DESIRABLE?

"The majority of street railway men will answer the above question with an emphatic, no. City officers will be found divided on the subject. Telephone companies are generally in favor of them, for the same reason that they are in favor of double trolleys; because they permit telephone companies to carry on business in a more slipshod manner than would be the case were they used.

The following letters from men who have had abundant experience with guard wires present the case in a very clear and practical manner.

M. R. McAdoo, manager of the Paterson Railway Company, Paterson, N. J., after a painful experience with the guard wire nuisance, says:

"I am most decidedly against guard wires for the reason that they are directly over the trolley wires, and as they are always coming down no matter how securely they are put up, they are then, when down, necessarily from their location, always charged. So far as protection against having live wires of the other companies such as electric light and telephone, on the ground, and lying across the trolley wire, should there be no guard wires, is concerned, I do not think this would occur nearly so often as live wires on account of broken guard wires. I have recently had a great deal of trouble which bears me out in this statement. I have also recently discovered that it is the telephone companies who are prodding up the city councils to require guard wires, as it facilitates the stringing and handling of their wires when in process of construction. This may apply more or less to the electric light companies. I feel satisfied, that if the city councils understood the subject to any extent they would agree that it is more protection to the telephone companies and other corporations than it is to any passengers on the street."

Maurice Hoopes, electrical engineer of the Lynn & Boston Railroad has the following to say on the subject. His opinions are also endorsed by Superintendent E. C. Foster.

"Our experience is wholly in favor of the absence of guard wires. Our Salem division has guard wires throughout, whereas the Lynn and Chelsea divisions have none. Capt. Hillar, the Lynn city electrician, is very decided in his opinion that they are not only useless, but dangerous, and would not allow us to erect them if we desired to. In Salem our lines are of more recent con-

struction, and hence in better condition, than in Lynn. Notwithstanding this we have more emergency calls in Salem than in Lynn, largely because of trouble with guard wires.

"The troubles caused by guard wires are due to their breaking, or being broken by trolley poles, and coming down on the trolley wires and into the street, and to an occasional section becoming alive, from defective insulation, and charging wires being pulled over it by linemen engaged in erecting other wires. Decidedly the better way to avoid danger from other wires becoming alive from trolley wires is for the owners to erect and maintain them in such a way as to make the chances of their coming down few. In cases where trolley wires pass under trunk lines of light iron telephone wires it may be well to protect them, for the one span, with guard wires, making them heavy and strong, with poles stiff enough to carry them. Undoubtedly the practice of putting up guard wires over all trolley wires, whether needed or not, results in much more damage and danger than their entire absence does, and while there may be a few spans in each city where their use would be advantageous, there are very few."

Richard McCulloch, electrical engineer of the Cass avenue & Fair Grounds Railway, of St. Louis, confirms the opinion of the two preceding gentlemen:

"The city authorities here do not compel us to erect guard wires except where a telephone or lighting wire crosses above us, and except in the down town district there is very little guard wire up. Of course, the object of the guard wire is to prevent a telephone wire from being charged from the railway circuit in case it should break and fall across the trolley wire. The telephone company in this city evidently does not believe in the efficacy of this preventative as it has recently adopted the plan of placing fuses on all its telephones. However well the line construction may be done, any increase in the number of wires put up adds to the danger of their breaking and getting charged. We use insulated steel wire for guard wire and try to have the guard wires thoroughly insulated from the poles and from the trolley, but every now and then the trolley pole flies off the wire or a strain insulator breaks and the result is a loose dangling wire, although no material harm may be done. In conclusion I would state that it seems to me that guard wires as a safety device are a failure, as they more often get us into trouble than keep us out of it. Furthermore, the system itself, seems to imply a loose construction on the part of telephone and lighting companies which it would not be well to encourage."

The general conclusions to be drawn from these opinions are:

1. Guard wires cause more trouble than they prevent. It would certainly be to the interest of electric railways to erect guard wires if they would prevent the railway from getting into trouble either from interruptions of traffic or damage suits. As long as the practical experience of railways demonstrates that they are a failure as a safety precaution no theory to the contrary should be considered for an instant.

2. The way to prevent accidents is by better construction of electric light, telephone and telegraph lines, and not by guard wires. Better construction of this class of overhead lines will not only prevent crosses with trolley lines but will eliminate a great many accidents not connected with trolley wire crosses.

THE UNIVERSAL BRACE-BAR HANDLE.

The Universal Brace, manufactured by the National Manufacturing Company, Wilkesbarre, Pa., is now made in the two styles of handle as shown in cuts here-

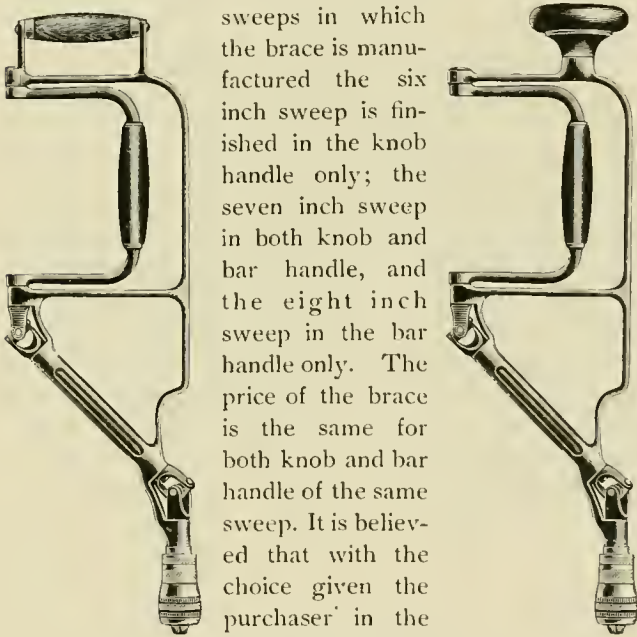

with. Of the three sweeps in which the brace is manufactured the six inch sweep is finished in the knob handle only; the seven inch sweep in both knob and bar handle, and the eight inch sweep in the bar handle only. The price of the brace is the same for both knob and bar handle of the same sweep. It is believed that with the choice given the purchaser in the style of handle, the

universal brace will satisfy the wants of the trade, however exacting. The purpose of the Universal Brace, as will readily appear, is described as being for boring and screw driving in angles and corners, close to washboards and walls, and in all places difficult or impossible to reach with the ordinary brace. The universal brace does the work of the ordinary brace and its special work besides. The brace is held in any desired position with one hand, and the crank-arm turns a right angle with the frame. All parts are simple and durable. In case of damage any part can be duplicated."

PASSES have been cut off by the Pittsburg, Allegheny & Manchester Company and the Pleasant Valley Company, both of Pittsburg.

GENETT BRAKES IN ACTION.

Probably no car in Atlanta carried more passengers during the convention than the one shown here, which was equipped with the Genett air brakes with double action pumps, manufactured by the Genett Air Brake Company, New York City. The brakes worked perfectly, under not particularly favorable circumstances.



The many heavy grades gave a good opportunity for the demonstration of its utility, which gave greater satisfaction to the investigators than if the tests had been made on level track. Tests were made to satisfy the most ingenious whims of the street car men, who were determined to find its weak points. General Manager E. J. Wessels was well pleased with the work of his brake. The car had McGuire trucks.

QUAKER CITY SIAMESE TWINS.

Peter A. B. Widener and William L. Elkins, the trolley and cable kings of Philadelphia, are certainly entitled to the pseudonym which has been conferred upon them by their fellow townsmen of the Siamese Twins of the Quaker City.

They are united in business and in social matters.

Their mansions are situated opposite each other on North Broad street, and each is engaging the other in friendly rivalry as to which shall eventually own the greatest art collection in the United States.

When one goes to Europe the other goes, too. Their tours in the United States are made in company. When one has business in New York the other has business there also.

According to this rule they both appeared at the Waldorf last week, and, if those who should know are to be believed, their consanguinity of spirit extended even to the items of their meals.

In their case, evidently, the beautiful aphorism of Richard Swiveller, Esq., is amply verified, and the wing of friendship is never likely to moult a feather.

THE new electric railway at Depere, Wis., will have two engines of 100 horse-power each.

## NOTES ON THE GROUND RETURN.

An experiment tried last year on the Chicago City Railway showed that cable tracks make remarkably good conductors for the return current on an electric road. The State street cable line is the main artery over which the greater part of the current must return to the electric station which is located near State street. For a time the road was operated by thoroughly bonding the cross town electric lines to the cable line at crossing points. The cable track was not bonded and no supplementary wire was run along it. Fearing that the return made in this way was not good enough the company laid a 500,000 circular mil conductor between the cable tracks from Sixty-third street to the power house at Fifty-second street, a distance of  $1\frac{1}{4}$  miles. The Sixty-third street line at that time had the heavy World's Fair traffic. When the 500,000 circular mil cable was connected up at the power station it was found that only 23 per cent of the current returned through it and the balance came through the cable tracks. In other words the double track cable road had a conductivity three times greater than a 500,000 circular mil copper conductor or was equivalent to a 1,500,000 circular mil copper conductor (about seven No. 0000 wires). That an unbonded cable track should have such a conductivity seems wonderful. To provide for the extensions now being made on this system the State street line is being double bonded with No. 0000 "Chicago" rail bonds and on some portions copper cables to the amount of 1,500,000 circular mils will be laid as supplementaries in addition. The Wentworth avenue electric line which parallels State street and will help form part of the main return to the power station will be double bonded with No. 0000 "Chicago" bonds. As these lines will feed in to the power station from two directions the return circuit will be the equivalent of sixteen double bonded rails besides the supplementaries spoken of. The track is girder rail of from 63 to 85 pounds per yard. Over 200 motor cars will be in use when extensions are made in accordance with present franchises, and how many more in the course of a few years "no man knoweth." The total conductivity of the return will be greater than that of the outgoing trolley feeders. As the trolley lines will be sectioned, with a separate feeder for each section, whereas the return is necessarily on the "network" system, so that the conductivity of all the circuits is more or less utilized, and as the drop in voltage in the overhead trolley feeders is to be less than ten per cent, it will be seen that a magnificent return is being provided. It will be one of the few large railway systems in the country on which the return circuit is intelligently installed. On most roads this item is the subject of guess work rather than electrical engineering.

THE receipts of the street railway of Halifax, N. S., for September were \$104,152, the largest in its history, and the city's share was \$8,332. In September, 1893, the receipts were \$92,745.

## COMPARATIVE LIFE OF ENGLISH CABLES.

Cable road managers will be interested in the following table, showing the comparative life of several makes of ropes on the lines in Dunedin, New Zealand:

## RECORD OF ROPES ON ROSLYN COMPANY'S LINES.

Nos.	1-2	Made up of odd pieces colliery ropes bought locally.		
		Maker.	Put on.	Taken off.
No. 3.	Old lay,	R. S. Newall	March 19, '84	Feby. 22, '85.
No. 4	Langsley,	G. Craddock & Co.	Feby. 22, '85	May 3, '87.
No. 5	"	"	May 3, '87	Aug. 9, '89.
No. 6*	"	"	Aug. 9, '89	Sept. 21, '91.
No. 7.	"	T & W. Smith	Sept. 21, '91	April 17, '93
No. 8.	"	D. H. & G. Haggie	April 17, '93	

\* This rope was on during the Dunedin exhibition and did exceptionally heavy work

## RECORD OF ROPES ON THE MORNINGTON COMPANY'S LINES.

Main Line.	Maker.	Put on.	Taken off.
No. 1.	Bullevant & Co	March 21, '83	Aug. 17, '84
No. 2.	F. W. Scott	Aug. 17, '84	July 15, '86.
No. 3	Craddock & Co	July 16, '86	Dec. 8, '89.
No. 4.	"	Dec. 8, '87	July 13, '93
(180,234 miles—3 years 7 months, 5 days)			
No. 5.	T. & W. Smith	July 13, '93.	
Extension Line.			
No. 1	Craddock & Co	March 10, '85.	Nov. 28, '87.
No. 2	"	Nov. 28, '87	Feby. 8, '94.
(53,752 miles—6 years, 2 months, 10 days.)			

The No. 4, which made the 180,236 miles, was in sufficiently good condition when taken out to be sold and put to work for colliery haulage, where it did good service.

The main line, Dunedin to Mornington, is 1 mile in length (double track); verticle rise, 450 feet; gradients traversed, 1 to 6; curve radius, 250 feet; length of cable spliced and running, 2 miles, 95 yards; speed of travel, 8 miles per hour.

The extension line, Mornington to Maryhill, is half a mile long (single track). The grade is 1 in  $3\frac{1}{2}$ ; curve radius, 75 feet; length of cable spliced and running, 1 mile, 143 yards; speed, 8 miles per hour.

## WANTS GOLDEN CHARIOTS.

An unregenerate editor who objects to open cars in November, lets himself out like this:—

"Put those pneumonia-breeding open cars in the barn. This isn't summer. Nobody's in training around this town for north pole hunting. Nobody wants to get in trim for a coffin. People are not crying for rheumatism. Nobody wants a cold that will last all winter. There's no fun in shivering. Haul 'em in. Lock 'em up. Look out for the health and comfort of your patrons. The only fit punishment for street car magnates who will run open cars on a day like this is to dress them in nothing but gauze underwear, tie 'em on to the front end of a motor, and run 'em around the belt at the rate of twenty miles an hour."

THE Consolidated Traction Company, Jersey City, N. J., has ordered twenty Columbian trucks of the McGuire Manufacturing Company, Chicago.

## THE ELECTRIC STREET RAILWAY AT ITHACA, N. Y.

BY JOHN C. TRAUTWINE, THIRD.

The city of Ithaca, N. Y., situated a mile or two south of Cayuga Lake, lies chiefly upon a low plain which stretches southward from the head or southern end of the lake. Immediately to the east of the town rises East Hill, upon the brow of which, and about 400 to 500 feet above the lake, or 800 feet above the sea, is located the world renowned Cornell University, commanding a beautiful view over the town and the lake. The erection of the college buildings on the hill has naturally caused the town to extend in that direction. The Ithaca Street Railway Company's system consists chiefly of three lines radiating from the intersection of State and Tioga streets,

were run over a curve with a radius of 40 feet, and with a grade of about 8 per cent at State and Eddy streets; but as the curve and grade were found to be too severe for cars going up, a "Y" was added, and this also affords a passing point for the cars. In the view, a down car is seen waiting on the curve, while another car, on the left, is seen coming up, to reverse on the "Y" and proceed up the hill on the track shown on the right. The branch crossing Cascadilla Ravine to the University campus, is carried by an iron bridge, built in 1893, by the Croton Bridge and Manufacturing Company. The ravine is 40 or 50 feet deep, and about 125 feet wide. The bridge, 35 feet high from the tops of the foundation piers, is about 140 feet long. It has five openings, the central one being spanned by a Warren truss, 61 feet long and 10 feet deep. The other spans are each 20 feet long and are formed of 15-inch "I" beams. The bridge

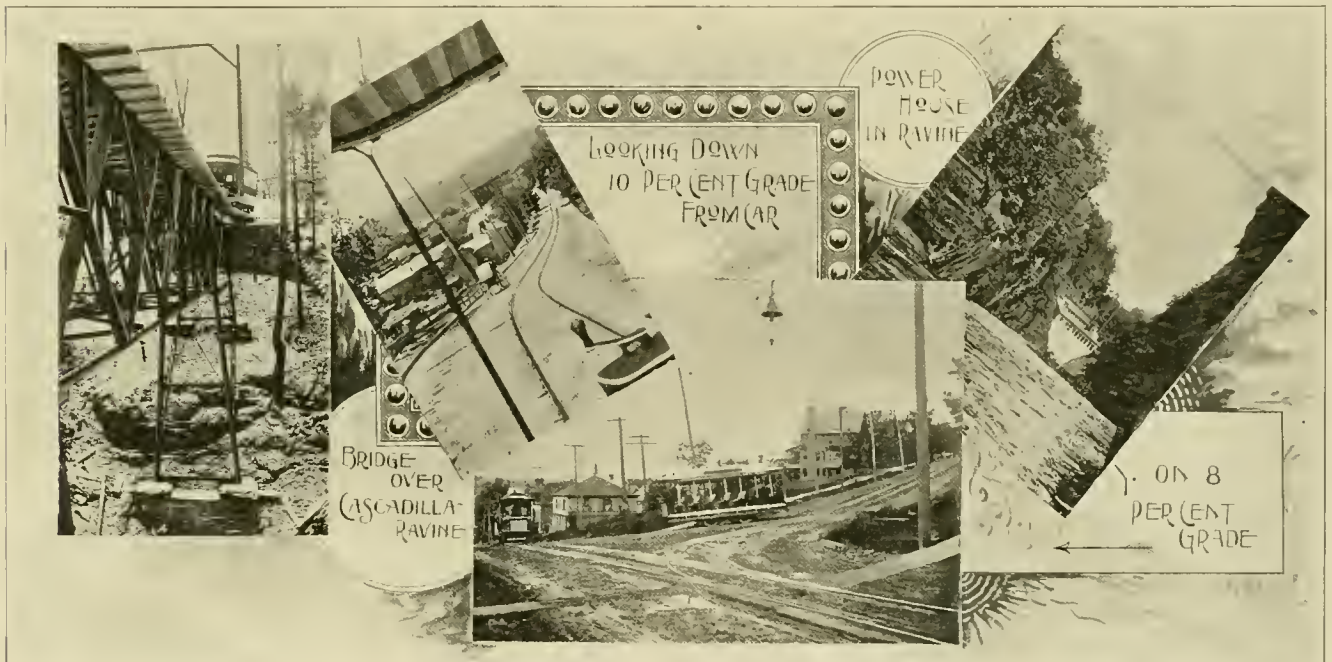

in the heart of the town. Two of the lines occupy the level portions of the town, one running westward along State street to the stations of the Lehigh Valley and the Delaware, Lackawanna & Western Railroads, and the other northward to the steamboat landing, with a recently constructed branch to a pleasure resort on the lake shore. The third line, running eastward, climbs East Hill via State and Eddy streets, to the station of the Elmira, Cortland & Northern Railroad. A short branch from this line crosses the Cascadilla Ravine and enters the college campus, but only for a very short distance, as its presence might interfere with the electrical work carried on in some of the college buildings. The profile shows the line between the Lehigh Valley Railroad station and the campus. For several hundred feet on the hill, the grade is between 9 and 10.5 per cent. The accompanying photograph was made from the car while running down the 10.5 per cent grade. At first, both the up and the down cars

is on a 5 per cent grade. Brackets on each side of the bridge support wooden poles which carry the supports for the trolley wire. The branch to the lake crosses Fall creek by a through, Pratt truss, single span, skew bridge, built by the same company. During late years, cars have been run regularly, every day, in spite of the heavy snows which frequently fall. The track cleaners are often sufficient to remove the snow, but it is sometimes necessary to employ men with shovels, or a plow without wheels is dragged over the track by four or six horses. No electric plow has been used. Sand is carried on all the cars, and most of the closed cars are well heated by electric stoves. On the hill cars, brake shoes last about two weeks. The Ithaca Street Railway Company controls not only the electric road described, which comprises the entire street railway system of Ithaca, but also all the electric lighting of the town, for which it has about one hundred arc and two or three thousand incan-

descent lamps. The power house occupies a recess formed by blasting in the right bank of the Ithaca gorge, through which runs Fall creek. A photographic view of the gorge and power house is shown herewith. Water is diverted from the creek and led through a pipe 5 feet in diameter and about 600 feet long, to the turbines under the power house, with a head of nearly 100 feet. As there are, in the ravine, numerous natural falls, one of which may be seen to the right of the power house, it was not necessary to build a dam. The speed of the turbines is maintained uniform by means of governors which control valves in the pipes, admitting more or less

TALE OF A \$5 GOLD PIECE.

These \$5 gold pieces which our government has coined for us, cause this long suffering people a deal of annoyance, still there is no one but would enjoy having his trouble multiplied by the possession of more gold. They are always being mistaken for nickels or pennies, but seldom are nickels mistaken for gold pieces.

A man in Chicago gave a \$5 gold piece to a street car conductor under the impression that it was a nickel. He did not discover his mistake until after he had left the car and entered his home. Immediately he set off for the car barns to hunt up the conductor, but it was of no use, for he could not remember the number of the car nor the appearance of the conductor. In vain did he rack his brains to recall some particular circumstance that would serve to identify them, and was forced to return home, expecting never to see his \$5 again. His wife went shopping next day with a neighbor. In paying for a purchase the neighbor handed the salesman a \$5 gold piece.

"Oh, those dreadful gold pieces," exclaimed the wife of the man who had been unfortunate.

"Don't say that," said the neighbor, "my husband received this in change last evening on a street car. He gave the conductor a quarter and received, as he supposed, four nickels in change. After coming home he discovered that one of the nickels was this gold piece."

"It is strange, but my husband was the victim of a similar mistake last evening. He paid one to a conductor, thinking it was a nickel."

"I wonder if my husband received your husband's gold piece."

"Impossible."

It was possible just the same, for when the two men came together and compared notes, it was found that both had ridden on the same car that evening, one in front and the other on the rear platform. There seemed to be no reasonable doubt that the conductor had received the gold piece for a nickel and given it out for a nickel. The money was returned to its rightful owner. This story is vouched for as being true, however strange it may seem. For a story of remarkable coincidence it equals the pleasant fiction of the man who caught a fish that had in its stomach a ring which he had accidentally dropped into the sea years before.

TAR AS FUEL.

Tar is being tried as fuel for steam boilers by the Melbourne Tramways Company, of Melbourne, Australia. The tar is kept melted by a coil of exhaust steam pipes in a large tank. Thence it is pumped through a strainer and up to the feed tanks over the boilers. From these tanks the liquid tar passes through a 2-inch pipe into the furnace, where it is blown into spray by a steam jet and completely burned. The tar and steam pipes have flexible joints at the furnace door plate, so they can be easily swung back as the furnace door is opened.

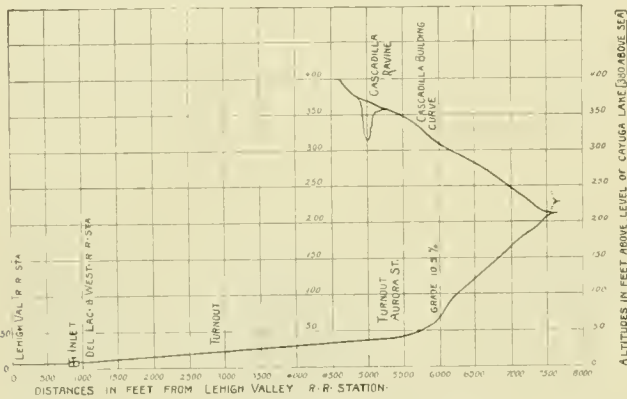

PROFILE OF ROAD.

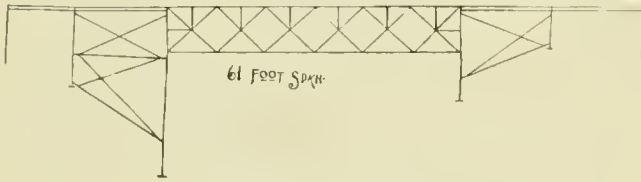

BRIDGE ACROSS RAVINE.

water, as required. An inclined plane was used to lower the building material from the higher ground to the site of the power house. It is still used for lowering coal for a Ball engine of two or three hundred horse-power. This engine is used on those rare occasions when the water of the gorge is too low to run the turbines, or when the turbines or the upper end of the pipe become clogged with sticks or ice.

CHICAGO COMPANIES' LICENSE FEES.

Chicago street railway companies have paid into the city treasurer \$51,731.42, for license fees, during the first three quarters of the year. The license fee is \$50 per car a year. The Chicago City Railway Company and the West Chicago Street Railroad Company run quite evenly, the former paying \$15,249.38, and the latter \$15,228.29. The North Chicago Street Railroad Company paid \$8,576.25; Calumet Electric Railway Company, \$1,718.25; North Shore Railway Company, \$213.25; Lake Street Elevated Railway Company, \$4,000; Chicago South Side Rapid Transit Company (Alley L), \$6,750.

The Mission Street electric line, San Francisco, was opened to traffic September 15.



## THE EVOLUTION OF ELECTRIC TRACTION.

Abstract of a Paper Before the Brooklyn Electrical Society, by  
William Clinton Burling.

It has been said that "The civilization of a country may be gaged by its methods and means of communication," and if countries, cannot times be considered by the same standard? If so, this, the last quarter of the nineteenth century, is the highest civilization the world has ever seen, and one nation, America, may be said to lead the world in the invention of such methods and means.

Still, there was one class of transportation that remained practically the same, from its inception until within the last few years, and that is the street railway. Beginning with horse<sup>s</sup> as its motive power, over fifty years passed without an essential change in the method of propulsion. Many attempts have been made to displace the horse by mechanical contrivances, applied in the shape of steam, compressed air, gas, cable, etc., but it is safe to say the electric railway is the one that will, and, in fact, has superseded, all other means of car propulsion in the majority of our city streets. This noiseless, tractable form of energy, devoid of all smoke, cinders, ashes, disagreeable odors, and noxious gases, and with its great reliability of operation, is far superior to any other system now in existence.

Although the cable possesses many of the good qualities of the electric motor, the latter far surpasses it, in that the road does not depend entirely upon the integrity of a continuous cable, from power station to end of road and back, wherein any stoppage means total interruption of traffic, and any damage in one part disables the whole line. No catching of grip in loose strands and cars running away is found with the electric road. The speed is much more under the control of the motorman, and the cars can be run in either direction, on the same track. Also there is not as much difficulty with switches and cross overs. These are only a few of the great advantages of electric railroads.

The first attempt at an electric railroad seems to have been made by Thomas Davenport, an American blacksmith, residing at Brandon, Vt., who, in 1835, built a small circular railroad in Springfield, Mass. This same man, in 1840, printed the first newspaper ever run out on a press using electricity as its motive power. It was called the "Electro-Magnet and Mechanic's Intelligencer." In 1837, Richard Davidson, a Scotchman, built an electric locomotive weighing five tons, which he claimed to have run on the Edinburgh & Glasgow Railway, and to have attained a speed of four miles per hour. Some seem to throw doubts on this motor ever having moved his 5-ton locomotive any distance whatever. In the fall of 1845 the Mechanics' Magazine, of England, published a letter signed "J. M.," which, as far as I can learn, is the first expressed idea as to the practicability of an electric railroad system, operated with a power station. The writer of the letter argued in support of his idea as follows: "Suppose we have a railway ten miles long,

and at one terminus is placed an enormous stationary galvanic battery. Might we not make the rails themselves the conducting lines of the battery, the wheels being so arranged as to break the connection when required. A rotating magnet might revolve by the electro-magnetism thus communicated. Perhaps some fertile brain may take the hint, and bring forth soon the ideal electric railway." A fertile brain in this country did work out the idea, and, in 1846, John B. Lilly\* exhibited, in Pittsburg, Pa., a model of an electric car, which was driven by a current passing along one rail, up through the motor, and down the other rail. This seems to be the first record of the approach to our present system of power stations.

Professor Page, of the Smithsonian Institute, at Washington, aided by an appropriation from congress, constructed an electro-magnetic locomotive, about forty-five years ago, which was claimed to be of 16-horse-power, and provided with 100 Grove's nitric acid cells, the platinum plates of which were eleven inches square. An experimental trip with this novel machine was made on April 29, 1851, between Washington and Bladensburg, 5½ miles, on the Washington branch of the B. & O. Railroad. It started very slowly, so that a boy with ease could keep pace with it. The speed soon increased, however, and before half the distance was traveled it was said to have attained a speed of nineteen miles an hour. It only continued at this speed over about one mile of track, however, before some of the battery cells cracked, the fluids became intermixed, and the current stopped. These and other pioneer experiments in electric railroading did not prove commercially successful, though they demonstrated the possibilities of electricity as a motive power. Not until the invention of the dynamo did electric railroading become a practical possibility. The early experiments, as shown, were carried on with primary batteries as the source of power, and with motors which gave but small efficiency, and it was not until 1873, when Gramme discovered by accident, that the dynamo could be used as a motor, that it was made possible to operate electric railways commercially. A little anecdote in connection with this discovery of the motor may be of interest. It is said that at the Vienna Exposition of 1873, Gramme had several dynamos on exhibition, and a careless workman, in setting two of them up, connected their wires together. When the belt was applied to one, to the surprise of the workman the second dynamo's armature began to rotate in the opposite direction to the one to which the belt was applied. He soon reported the matter to Gramme, and this accidental discovery may be said to have completely revolutionized all forms of electric motive power. Although several electricians experimented in a small way after this discovery, but little practical advance was made in electric railroading until 1879, when Dr. Werner Siemens built the first economically operated electric railway, at the Berlin Exposition. This consisted of a narrow gage line, laid in a circle, some 900 yards in circumference. A third rail was placed between the tracks, and insulated on wooden

\*For full description see STREET RAILWAY REVIEW for March, 1893.

blocks placed above the ground, from which, even in wet weather, there was but little chance of leakage. The car tracks were used for return conductors. On this road was run a motor which was capable of exerting five horse-power, and which drew two or three trail cars, with a capacity of twenty or thirty persons. During the summer 100,000 persons were carried on this road, and it was considered on all sides a success. Thomas A. Edison was the first inventor to build a dynamo electric railroad in this country. In the spring of 1880, at the expense of Henry Villard, he constructed a short line at Menlo Park, N. J. It was a success, and people from far and wide came to see it. In the next year, 1881, Dr. Siemens built a line at Lichterfeld. This was the pioneer street railway constructed for regular passenger service. In this same year, he, and Mr. Halske also, exhibited at the International Electrical Exhibit in Paris another electric railway. In 1883 Stephen D. Field exhibited an electric locomotive at the exhibition of railway appliances in Chicago, while in the same year an electric line six miles long was constructed between Port Rush and Bush-Mills, Ireland. This was built on a 3-rail system, the main conducting rail being placed near the fence, on wooden posts eighteen inches high, for the purpose of insulating it from the ground. This is the first record to be found of the conductor being raised in the air, and seems to be the first idea the Europeans had of raising their conductor above the ground, and utilizing the air for an insulator. An American, Dr. Joseph R. Finney, of Pittsburg, Pa., a year earlier, in the summer of 1882, designed the first overhead trolley, using a wire as the conductor. He was also one of the first in this country to conceive the idea of placing the motor directly on the passenger car. From this it will be seen that our own country has made greater progress than all the rest of the world included in the application of electricity to railroads. The first electric street railroad opened in America, for actual commercial service, was a line between Baltimore and Hampden, Md., two miles long, which was put in operation September 1, 1885. The electric machinery was designed by Leo Daft. In May, 1887, two years later, T. C. Martin read a paper before the American Institute of Electrical Engineers, in which he showed that there were then in operation in the United States thirteen electric railroads. In 1890 there were about 250 railroads equipped with electric power. Now to see cars propelled by horses is the exception, and nearly every railroad line so propelled is considering the use of some form of electricity for its motive power in the near future.

In the matter of carrying current to the cars, the first overhead trolleys in Europe used a slotted tube. Contact was made by a sliding piece of metal, running inside the tube, and connected with the car by a flexible cable. In this country Dr. Finney had given us the idea of using wire, that was generally adopted for overhead conductors, and the example set by us has been followed all over the world.

In the first overhead trolley construction in this coun-

try, the trolley wheels, or contact trucks, as they were sometimes called, consisted of a small carriage or truck, which ran on top of the wire and was connected with the car by a flexible cable. It took an enormous amount of experimenting before what appears to us to-day so simple, the under contact trolley, with its arm, springs, and wheel, was evolved.

It was soon found that an individual electric locomotive for every street car would be a great waste of money and loss of power. Inventors, therefore, turned their attention to placing the motor directly on the passenger car. At first they placed the motor on the platform, or inside the car, and connected it with the axle by sprocket and chain. But this took too much space otherwise available for passengers, besides too much loss of power. So inventive genius tried placing the motor under the body of the car. Although this now seems to us very simple, it proved no easy task. The truck had but a limited amount of available space for a motor, and the early motors were not as compact as at present. Economy of weight and space, as well as of power, required that the motors be run at high speed, and as the wheels revolved at a comparatively low rate, it is evident that some means of reducing speed was necessary. A long line of experiments was carried on, until now we have the slow speed multipolar single reduction motor. Most of our cars to-day are supplied with two motors, a few of the advantages of which are that the speed can be changed with less loss of power, by connecting up the motors in parallel or series, or by running one motor alone. The power can also be communicated evenly to both pairs of wheels. A few years ago, William Baxter, Jr., conceived the novel idea of enclosing the motor entirely within the car wheel, thus relieving the axles of all strain due to the weight of the motors. This idea has not been adopted to any great extent, on account of having to run the motor at low speed.

The storage battery has raised great hopes as a means of car propulsion, but the investors in this system have met with sad disappointments. More money has probably been lost in attempts to develop this system than any other form of electric car traction.

Many inventors have taken out patents embodying the principle of a closed conduit with contact points placed inside an open conduit. These, on short experimental lines, built on favorable conditions, have appeared to work well. The great number of moving parts, however, and the liability of their getting out of order, besides their inaccessibility, makes investors hesitate in putting money in them.

The Bentley-Knight system was tried in New York a few years ago. In this construction a conduit was placed alongside one of the car rails, and two conductors were used, one placed under each slot rail and in close proximity to it. This system failed through the insulation and drainage both being insufficient. The Siemens-Halske system has proven successful in Buda-Pesth, but it is questionable whether it would work satisfactorily in our climate. In this system the conduit is very large,

thus getting ample drainage and plenty of room for air insulation. There are two rails used as conductors, one on each side, supported by insulators fastened to the side walls of the conduit. This system, I believe, has not been tried in this country.

The Love system, in use in Washington and Chicago, consists of a conduit similar in size to that used for cable roads. Flat slot rails are used, from which there is a projection downward along the slot opening, which protects the wires from drippings which may come from the street. Two wires are used in this system, being held by insulators about four inches below each slot rail. This system has not seemed to work quite satisfactorily, however. I can best quote from a paper read before the American Institute of Electrical Engineers, in New York, by a prominent electrical engineer recently:

“With regard to the Love conduit, I have had the good fortune to examine the only two roads operated on this system, the road in Chicago and the road in Washington. The former is 1 5/8 miles long, circumventing several blocks. I made several trips, and on three trips we were shut down from one cause and another twenty-three times. I do not consider it a success. In Washington, however, the road is vastly improved, and is run on a street where the conditions are far better than in Chicago. The street is beautifully paved with asphalt. The road started on March 2, 1893. It has not been all plain sailing with them there. They have had trouble largely from mechanical difficulties, so far as I can see. The slot rail turns down along slot opening, and the trolley wheels come very close to the iron, and there is evidence that sparks pass from wheels to the iron. I found that trolley wheels lasted but ten days. I do not claim the Love conduit is a success by any means, but in my judgment it is to-day the nearest approach to a successful conduit system of any that has been put to actual test of street traffic.”

Mr. Griffen, of the Electrical Conduit Traction Equipment Company, visited Washington last fall to inspect this system, but while he was there found it inoperative during the whole time.

### CHARLES K. LAWRENCE IN PRISON.

Charles K. Lawrence is now serving a sentence of two years and five months in the Auburn, N. Y., prison, for embezzling a street railroad valued at \$25,000. In 1891 he was given a contract to rebuild the Lockport Street Railroad, six miles long. He tore up the old rails, with the understanding that he was to relay entirely new ones. The cars, he said, would have to be almost refitted, so he shipped them to Buffalo. From that point cars and rails were shipped to Marion, Ind. Soon afterward Lawrence left town.

Lawrence was arrested in Erie, Pa., brought to Lockport, tried, convicted, and, in June, 1892, was sentenced for two years and five months. He was in jail three or four months pending an appeal, which resulted in his

release. The railway company appealed, and received a decision confirming the first. Detectives were put on the track of Lawrence, who was captured after a long search. He is now wearing stripes.

### ROUTED THE MILITIA.

Tacoma, Wash., has a street car conductor who successfully put to route seventy members of the militia in full uniform. About 7 o'clock in the evening Conductor Bybee of the Old Town line caught a load of seventy members of the militia. They behaved like ordinary passengers until he began to collect the fare. The first man refused to pay, and the others rallied to his support, saying they were going to run the car to suit themselves.

Like a great strategist, Conductor Bybee let them have their way for a time, as he did not care to tie up the entire line. When he got to a convenient switch, he side-tracked the car. Taking the switch iron in his hand, he ordered himself to “fall in.”

The reconnoitering party reported the enemy in camp, but without pickets. With this information it was decided to make sudden attack, and with all the force, paying no attention to the rear. The order to advance was given, and the enemy being taken by surprise, hesitated and was soon in full retreat.

Conductor Bybee, having won the first skirmish, decided to change his position, so he started the car, placing a rear guard on the platform. The enemy rallied and made an advance but was repulsed.

### RACK RAIL FOR MOUNTAIN ROADS.

La Societe Anonyme d'Ougree, of Ougree, Belgium, has introduced a new rack rail for mountain roads, which consists of two angle bars with or without iron plates being interposed. They are connected by rivets or bolts in which the teeth have been cut out. The rail is illustrated by the Railroad Gazette.

When only a low resistance is necessary, the rail con-

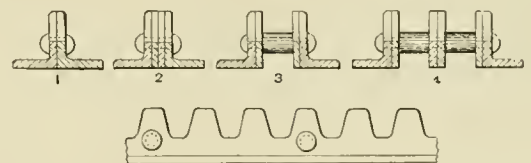

sists of two angle-irons, as in Figure 1, but iron plates are interposed between and bolted up with angle irons as in Figure 2, when the resistance is great. These plates can be increased as desired. Figures 3 and 4 show the angle irons not bolted close together, but spacers are used on the bolts, and the whole forms a double or triple rack rail. The rails can be laid on either wood or iron sleepers. It is claimed that the rail can be economically and rapidly manufactured and is quite safe on account of the transverse section of each tooth being composed of several elements.

## SELLING POWER FOR OUTDOOR AND FARMING PURPOSES.

Although the action of the insurance companies has practically prohibited the selling of power for stationary motors in insured buildings, there is still open a large field for stationary motors run from trolley circuits, outdoors and around the farm in small uninsured buildings. They are now being used in many places to run stone crushers for paving contractors, for making excavations, and for running brick and farm machinery. As far as we can learn, the first farm to make use of electric power was the "Crystal Hill" farm, near Catasauqua, Pa., while the first farmer to use power from a railway circuit on his farm was Hon. Jeremiah Roth, of Allentown, Pa.

Mr. Roth is the proprietor of the Allentown Stock Farm, which is located near the city limits of Allentown.



SCENE AT CRYSTAL HILL FARM.

He has always been one of the most progressive farmers in the locality, as is manifested by the fact that he is president of the Lehigh County Agricultural Society, which is a leading one of the state. He is also an ex-member of the Pennsylvania legislature. The power used on his farm is taken from the circuit of the Allentown & Lehigh Valley Traction Company. He has erected poles and wires for a distance of 3,300 feet, installed a 15-horse-power motor, and is running all his farm machinery around the barn with it. The motor is placed in a building back of the barn and is belted to a shaft, which shaft is supplied with pulleys for transmitting the power to various kinds of machinery. Thrashing, cutting feed, grinding grain, shelling corn, pumping water and sawing wood are done in this way. He also has electric lights in a barn 50 by 208 feet. The current is sold by meter, at eight cents per 1,000 watt-hours. After having tried electric power, Mr. Roth would by no means go back to steam or horse power. He says that it is cheaper than steam or horse power, and there is the advantage over steam of less danger from fire. He recommends it to other farmers as being the best system in existence.

Although there has for the last three or four years been much talk about supplying power to farmers along the routes of electric railways, such talk has principally been in the prospectuses of "fake" electric roads or in the pages of magazines. As far as we know at present, the Allentown & Lehigh Valley Traction Company was the first to actually sell power for this purpose. Since

Mr. Roth has put in electric power, a number of other farmers in the vicinity have become interested and A. F. Walter, cashier of the road writes us that they have had several other calls from farmers along the line, and expect in the near future to install other motors for this same kind of service. The road extends through sixteen good-sized towns, with a prosperous farming country between each, so that there is an excellent prospect for a good business.



HON. JEREMIAH ROTH.

The other installation spoken of at Catasauqua, Pa., while not run from a railway circuit, is interesting in this connection, as showing what can be done along this line. The "Crystal Hill" farm and dairy, near Catasauqua, handles a large amount of ensilage or corn fodder, and several years ago erected five large silos or special bins for storing it. These silos had a capacity of 1,000 tons. The expense of preparing the fodder for these silos was very great when done by horse-power, and steam power was used for some time, but coal had to be hauled a long distance by teams, and an engineer hired, so that although it was cheaper than horse power, the item of expense for power was still large. In October, 1892, W. M. Morrison, an electrical contractor of Catasauqua, induced the proprietors of the farm to try electric power. A 220-volt circuit was run from the terminus of the Catasauqua Light & Power Company's lines, making the total distance of transmission  $2\frac{1}{4}$  miles.

The first installation on the farm consisted of a 5-horse-power Crocker-Wheeler motor, which was used to operate the butter churns, a cream separator, milk aerator, bottle washer, and ceiling fans during hot weather, the same line being used to furnish current to lamps installed throughout the various buildings, and which are furnished with abundant light. The first installation having proved so successful, both in cheapening the cost of production and in operating the various utensils, it was decided to replace the 25-horse-power engine and boiler with a C.



ELECTRIC POWER, CRYSTAL HILL FARM.

& C motor (10 h.-p.), which soon demonstrated its superiority over the engine. About seventy head of Holstein milch cows are fed on this ensilage during the year, and the adoption of electric motor power has cheapened the cost of this food (ensilage) 65 cents per ton, it having cost \$1.50 per ton previously, but now is it stored in the silos at a cost of 85 cents. Thrashing and wood sawing are also performed by this motor, and the proprietors say that cleaner work on the thrashing machine they have never accomplished, as no grains are broken, by variable speed. These people are great advocates of this power, and have induced farmers in the vicinity to adopt the same method.

#### TRUE STORIES HEARD AT CONVENTION.

A well known street railroader from the east was in Kansas City the other day, and strolling along the street came upon a horse auction. Although his own lines have been converted into electric he still felt a kindly interest in his old friend the horse, and paused to watch the sale.

"Lot 17," cried the auctioneer, "What am I bid for lot 17?"

To all appearances "Lot 17" was a pretty little pony, with long mane and tail and a kindly face, and the subject of these lines bethought himself that it would be a great scheme to purchase the little equine for his small boy at home. So he bid ten dollars, and raised back several times by easy stages until seventy-five dollars was reached, when he stopped and so did every one else. He stepped up to the captain's office and planked down the funds and was assured he had secured a great bargain. He remarked he was satisfied, and taking hold of the halter, started away.

"Where are you going?" yelled the attendant, "and what shall I do with them?"

"Do with what them?" rejoined our man.

"Why, the balance of the lot, of course."

"What balance of what lot?"

The look of disgust that came over the horseman would have frosted a cabbage. "We want you to get your hosses out of here, so we can make room for more. You don't suppose we are going to board 'em until you get good and ready to ship, do you?" By this time the stable hands had lined up eleven as fine little bronchos as one could wish, which, with the one already led out, made an even dozen, and constituted "Lot 17."

Our friend has been busy giving horses away where he found a chance, ever since.

\* \* \*

"This reminds me of an experience which occurred when I was in Sioux City, last month," said the president of one of the largest street railway supply houses. "I had an hour to wait for the train and sauntered up the street. At a corner a crowd was gathered where the sheriff was selling out a lot of furniture and things to satisfy a judgment. Just as I edged into the crowd, a fine-looking carriage horse was trotted up, and the auc-

tioneer called for a starter. I thought it would be fun to bid a few times and drop out before a selling price was reached, so I sung out 'Twenty-five dollars.'

"Quicker than I can tell it, the auctioneer cried: 'I'm bid twenty-five; one, two, three, and sold for twenty-five. Here you are; next.'

"Well, it simply took my breath away, for I was several hundred miles away from home, and had as much use for a horse as a superintendent has for a car-starter. But the animal was certainly a fine one, and I concluded I would sell him at a great sacrifice for about fifty dollars, and clean up twenty-five dollars for my hour's time. So I smilingly paid the price and led him away, remarking it was a great bargain. Everybody else seemed pleased, too, and evidently envied my good fortune. So I started down the street, satchel in one hand, leading the horse with the other, offering the bargain to every one I met. No one seemed much interested, and when I stated the price, fifty dollars, looked at me in such a strange way I began to feel uncomfortable; and, then, a policeman sauntered along after, until it began to dawn on me that they took me for a horse thief. No one would buy. It lacked but fifteen minutes of train time. I got desperate, and asked for an offer. Finally, when I had just four minutes left, I struck a stranger and closed the trade at ten dollars. Then I ran three blocks, caught the rear car just as it pulled out, and sank back exhausted in the seat. I know more now than I did about horses, and next time I'll bet they don't get any such horse on me."

\* \* \*

"Tell you what happened to me," said a fat man, whose name is known to every street car man in the country, "I was in a sleeper the other night. Had a berth in the middle of the car, which was crowded. I had a fine sleep and, awakened in the morning feeling as fine as a fiddle. I made myself as agreeable as possible to the other passengers, who, however, all seemed worn and weary, and not at all inclined to be sociable. Finally, when all the berths had been made up, a dignified looking man took his silk hat in his hand and passing from passenger to passenger, spoke a word, upon which, each with great alacrity, went down in his pocket and deposited a coin in the hat. When all had been so visited he came to me and pouring out the money on my seat, said:

'My friend, this is for you.'

'But I don't want it,' I replied. 'What's it for?'

'A small token of our obligation for the music you rendered, and to which we listened all last night.'

"My wife has always insisted I snored, but now I believe it. I put enough money with the collection to get a box of fine cigars, and after the next station was reached we all smoked and peace was restored. Now I ride in the day time."

\* \* \*

"Those horse stories," said a listener, "remind me of an incident that occurred, when we sold a lot of horses,

having changed the equipment of our lines. A peddler secured two horses at fifty cents apiece. He started to take them home, but when he had gone about a mile, one of the horses fell down and died. That was in the days before the city authorities made a business of removing dead animals. Next day the peddler came to our office and wanted \$5 to pay for removing the horse from the street. He didn't care for the loss of his horse and fifty cents, but he did object to paying the \$5."

\* \* \*

"Do you gentlemen know what it costs to run a road in the smaller cities of this state?" asked the superintendent of a Georgia line.

"If you don't you will be surprised. We pay our conductors a dollar a day. They are recruited from the class known as poor white trash. If we were to pay them \$1.50 a day, they would be so rich at the end of the week that they would lay off for a week to spend their money. We have learned this fact by bitter experience. The second week we ran our road we were without help. If we pay our men only enough to live on, we can keep them steadily at work.

"Track laborers," he continued, "receive 75 cents a week and board. The board consists of molasses, bacon gravy and bread. When the men come to the table the first man pours the molasses on his plate, passes the pitcher to his neighbor, puts bacon gravy on top of the molasses, takes a piece of bread and sops it in the mixture. He continues the process until he has 'licked the platter clean,' when his meal is finished."

\* \* \*

Speaking of created travel, W. S. Dimmock, general superintendent of the Omaha & Council Bluffs Railway & Bridge Company, Council Bluffs, Ia., told how his company made Kelly's Commonweal Army earn it some money last summer. Great objection was made by the citizens to the arrival of the army, but Mr. Dimmock has a long head, and gave permission to use some of the company's vacant property for a camp. The camp was on the outskirts of the city, so it was desirable to keep the army there for a few days, in order to give everybody a chance to visit the camp.

"We not only furnished the camp," said Mr. Dimmock, "but we gave out rations. Our expectations were realized, for the people flocked to see the army. The eastern railroads refused to furnish a train to carry the army out of town. This got the laboring element up in arms, and about 5,000 of them started to march from Omaha. We heard of it, and thought they might try to capture our cars, so we sent them all over to the Council Bluffs side, and shut off the current.

"By this time the crowd had got to the entrance to the bridge. We could have kept them out, but there would have been bloodshed. When I learned that they were not after our cars, but simply wanted to cross the river, it flashed over me that these were citizens of Omaha, and they were going to live there, and would be

patrons of the road. Here was a chance to make friends. I also knew that they had to walk six or seven miles, and would be tired out when they got ready to return home, and would be glad of the ride, which was the only way they could get back. I figured they would do no harm if permitted to cross, and, if resisted, they would be enemies of our company and a bloody battle would result, for they were all crowded into a small space, and we had a force of policemen ready to shoot. I made a speech to them, and told them we would let them pass over the bridge free of charge, although we were entitled to toll. They cheered the company and marched over the bridge. But we caught them that night, and the two following nights, having permitted them to cross free in the day time. We had plenty of cars at the Council Bluffs end of the bridge, and every mother's son paid his little ten cents for a ride home, and there were several thousands of 'em, to. Some days after it began to dawn on the laboring element that the company had been coining money."

\* \* \*

Mr. Dimmock's story reminded George W. Baumhoff, general superintendent of the Lindell Railway Company, St. Louis, of a neat stroke that loaded his cars on October 6. He had a boat race between two women in tights, at Forest Park, which drew 30,000 people, 25,000 of whom rode on his line. One week later the women rowed a race on the Mississippi river, which attracted 75,000 people. The expense was only \$300. Mr. Baumhoff says next season he intends to have some swimming matches between women.

#### MONTREAL'S ANNUAL STATEMENT.

The Montreal Street Railway declared, on November 8, its semi-annual dividend of 4 per cent, and gives out the following statement, the best in its history:

	1894	1893.
Income per year, per cent of capital . . . . .	9.69	8.17
Surplus for year . . . . .	\$37,354.46	\$2,486.19
Miles run . . . . .	4,888,486	3,438,650
Miles run per day . . . . .	13,393	9,421
Cars run per day . . . . .	135	117
Trips . . . . .	811,747	564,929
Trips per day . . . . .	2,224	1,548
Passengers . . . . .	20,569,013	17,177,952
Passengers per day . . . . .	56,353	47,063
Transfers . . . . .	6,828,653	5,094,113
Transfers per day . . . . .	18,709	13,956
Transfers per cent of passengers . . . . .	33.2	29.6

THAT enterprising publication "Dixie" devoted to the interests of southern industry is at work on a movement to extend trade into South America and Mexico by means of international expositions. A circular letter has been sent out to the leading manufacturers asking whether they would co-operate in such a movement. Six hundred and sixteen have professed a willingness to exhibit. The majority of those who were willing thus to co-operate already do some business in the countries mentioned and recognize the value of such expositions to their trade.

LA CROSSE AND ONALASKA STREET RAILWAY.

One of the most enterprising of the many solid manufacturing towns of Wisconsin is La Crosse, the French origin of which is betrayed in its name. It has been an

transit. Since the change traffic has increased 100 per cent.

Mr. Canterbury being in feeble health resigned the presidency in favor of Hon. Frank Pooler of Onalaska, under whose management it is now operated, with Peter Valier as superintendent.



F. POOLER.

J. B. CANTERBURY.

P. VALIER.

B. E. EDWARDS.

important place from its earliest days as a commercial point and enjoys a reputation far in advance of its population.

One of the prominent features that has helped advertise the city is its remarkably efficient system of electric railway which is loyally supported by the 20,000 inhabitants of the town.

The line of the La Crosse City Railway comprehends 11 miles of standard gauge track laid with 48 pound T and 58 and 66 pound girder rail; 11 motor cars and 10 trail cars equipped a la General Electric. In connection with the line is a branch to the suburban village of Onalaska three miles distant. This line was built four years ago by J. B. Canterbury of La Crosse, more as a real estate venture than as an investment. The traffic on the branch seemed so profitable, however, that just recently the track was bonded, wire run and power rented of the City Railway and the Onalaskans now enjoy electric

The beginning of street cars in La Crosse dates back to 1879, when a few prominent citizens, for philanthropy's sake, thought they would build a mile and a half of horse car track from what is known as South La Crosse to North La Crosse. It was operated by horse power for six or seven years with wonderful success, paying 40 per cent on the investment.

The road was finally sold to B. E. Edwards, W. W. Cargill, G. C. Hixon, Henry Gund and others, for ten times the original cost, and new organization effected.

The line was then extended all over the city. It was operated by horse power until 1893, when electricity was adopted as stated.

The management is composed of pushing, enthusiastic men who believe in La Crosse and electricity. They are by name: B. E. Edwards, president; W. W. Cargill, vice-president; G. H. Clark, treasurer; H. E. West, secretary and Peter Valier, superintendent.



W. W. CARGILL.

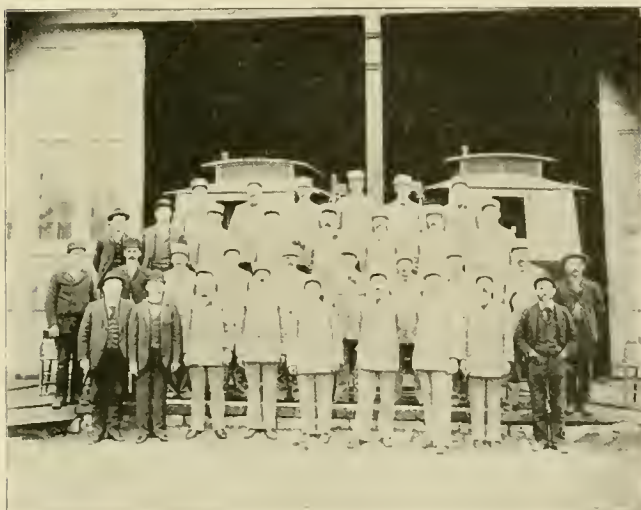

VIEWS OF THE LA CROSSE & ONALASKA STREET RAILWAY.

President Edwards is a pushing young business man, and to his wise counsel much of the success of the fine system is due. He is interested both patriotically and financially in many large enterprises.

Vice-president Cargill is another financier of ability. He is head of the large grain firm of W. W. Cargill & Co., which has branches in many cities of the northwest. He is energetic and progressive.

Peter Valier, superintendent, is a self-made man of Canadian extraction. He began with a meager education and by dint of pluck and ability has made himself a first-rate electric railway builder and manager. He is responsible for the smooth mechanical running of the system.

J. B. Canterbury is of Irish birth, an ex-Union soldier and an active citizen in every good word and work.

The Honorable Frank Pooler is a prominent politician and business man of Wisconsin. He has made a brilliant record and as he is only 40 years of age has still a wide future.

#### CHICAGO TRACK ELEVATION.

All of the steam railroads are being compelled by the City of Chicago to elevate their tracks within the city limits, in order to avoid grade crossings. The principal advantage to the railroads will be an increase of speed.

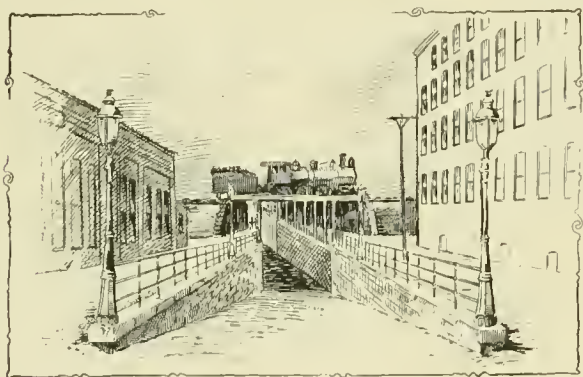

Where there are streets to be crossed they are depressed, and a subway built, as shown in our illustration. The new system will be of considerable advantage to the car lines, as many of them cross railroad tracks, and they can make better time, while the danger from crossing accidents will be entirely avoided.

A DIVIDEND of 3 per cent has been earned by the Columbus, O., Street Railroad Company for the nine months ending October 1. The gross earnings and rents aggregated \$421,166.96, of which \$197,781.56 was absorbed by operating expenses and \$132,307.65 by interest and taxes, leaving \$91,077.75 for the stockholders. The Columbus Street Railroad Company operates the Crosstown Street Railway Company, which, for the same nine months, made gross earnings of \$59,013.71 with operating expenses of \$23,474.38 and interest and taxes amounting to \$14,700.85, leaving \$20,838.48, net.

#### MADE THE FIRE FLY.

Some electric railway men were exchanging prevarications the other evening, when one of the party broke over the rule by telling a true story. As it was a good one, it was allowed to pass. The trolley wire broke one day, and a clerk in the offices of the company was instructed to go out and wrap the hanging down end around a pole. Now the clerk was innocent of all knowledge of electricity. He also had a refined taste, and as he went out to pick up the live trolley wire he saw an iron lamp post available, which was ever so much better to wrap the wire around than the vulgar wooden poles. A kind fortune kept him from getting a shock while he carried the live end across the street, and the first intimation he had of anything being wrong was when the wire first touched the iron lamp post. Electric railway men do not need to be told of the brilliant display of fireworks which immediately took place. The clerk started up the street on the run. He was probably as much surprised as a dog which came along where the boys were repairing the line one day and smelled of the end of a live trolley wire. The boys at first claimed there was a streak of fire a block long, but after cogitation concluded that it was simply the yellow dog under full speed.

#### CHARLES SCOTT SPRING COMPANY.

The Charles Scott Spring Company, of Philadelphia, has recently bought the lot adjoining its present factory and thereby secured frontage of 130 feet on Germantown avenue, 120 feet on Canal street and 43 feet on New Market street. A siding from the Philadelphia & Reading Railroad, running on Germantown avenue, will run into the works and greatly increase the shipping facilities. The new addition to the factory is now in process of erection and will be under roof by the middle of October. This new shop will be devoted entirely to the manufacture of elliptic springs. The old elliptic mill has a capacity of 100 tons of elliptic springs per month, but this was found inadequate to the growing business. With the new shop, the Charles Scott Spring Company will have a total capacity of nearly 3,000 tons of elliptic springs annually, while in the spiral spring department it has a capacity of 5,000 tons. This concern manufactures springs of every description, including springs for trucks, motors and trolley stands. Its brush-holder springs are acknowledged to be the best in the country. The company's business is increasing to such an extent that it is unable to look after it from the home office, and now has Arthur S. Partridge as the St. Louis agent and F. A. Lawson & Co., in San Francisco, Cal.

MENOMINEE, Mich., and Marinette, Wis., have been brought closer together by the extension of the tracks of the Menominee Street Railway Company across a bridge. Heretofore passengers have been compelled to walk a block to make the connection from one line to the other.





Interesting Bits of Information from all Parts of the Country,  
Boiled Down for Busy Readers.

THE Oil City Street Railway Company, Oil City, Pa., is making some extensions.

THE Citizens' Railway Company, Steelton, Pa., has been improving its roadbed.

THE Columbus, O., Street Railway Company has fitted up a reading room for its employes.

PHILADELPHIA runs trolley cars all night long on some lines. After midnight they make great speed.

POUGHKEEPSIE, N. Y., has its new thirty mile system in operation, which was built by Major J. W. Hinckley.

THE Sheffield Avenue line of the North Chicago Street Railway Company is now equipped with electricity.

UMBRELLAS, to the average number of 3,000, are constantly in the lost parcel office of the New York Elevated Railroad.

UNDER the supervision of Superintendent Fox, the Traction Company, Scranton, Pa., is building a mile and a half extension.

IN Philadelphia a motorman fainted at his post, the car ran away, there was a collision, and three passengers were slightly injured.

THE Haverhill, Merrimac & Amesbury, Haverhill, Mass., Electric Road, carried 1,346,043 passengers, between October 1, 1893 and October 1, 1894.

DURING the State G. A. R. encampment, the Citizens' Street Railway Company, Indianapolis, Ind., collected 75,000 fares one day from 6 A. M. to 12 P. M.

THE Baltimore City Passenger Railway Company paid \$24,964 park tax for the quarter ending September 30, which indicates gross receipts of \$278,488.

WORK has begun on the electric line from Asbury Park, N. J., to Branchport, which will make a new direct line to New York both for freight and passengers.

BETWEEN Elyria, O., and Lorain, an electric road has been constructed and put in operation by the Johnson Company, which is building a steel plant at Lorain.

IN this matter of street car accommodation, it may be said that the strap carries too much weight. It was never designed as a substitute for the seat.—Daily Fling.

THE City Railway Company, Wilmington, Del., has opened its new line to Gordon Heights. It is two miles long and runs to a summer resort on the Delaware river.

AN order of court requires Receiver J. C. O'Gorman of the Union Depot Street Railway & Transfer Company, Stillwater, Minn., to distribute \$25,000 among creditors.

ONE druggist in Owensboro, Ky., sold 9,300 street car tickets during a fair. The Owensboro City Railway Company carried 24,000 passengers Friday, and 30,000 Saturday.

WHILE uncoupling a trailer, a conductor in Terre Haute got his head tangled in a trolley rope and was almost unconscious when discovered, having been dragged several feet.

THE Milwaukee Street Railway Company has won its suit to have the assessment of its franchise declared illegal, and consequently the assessment will be reduced over one-half.

ARBITRATION has been adopted to fix the compensation of the Union Depot Railroad Company, of St. Louis, Mo., for the use of its track by the Southern Electric Railway Company.

A YOUNG man of Newark, N. J., has made a pleasure trip of eighty-five miles on the electric cars, running out of Newark, at an expense of \$1.50 in money, and thirteen hours of time.

THE newly elected officers of the Riverside & Arlington Street Car Company are: S. C. Evans, president; F. A. Miller, secretary; G. O. Newman, superintendent. The directors were re-elected.

PHILADELPHIA police made a raid by trolley. They captured the proprietor of a "speak-easy," whatever that may be, who had long boasted of his security, and had eluded the police for a long time.

THE consolidation of the Rochester Railway Company and the Rochester Electric Railway Company, Rochester, N. Y., has caused the abandonment of the latter company's power house and car barns.

THE Allegheny, Etna & Sharpsburg Electric Railway, of Allegheny, Pa., has opened a new line. The fare is five cents for the same distance for which two competing railroads exact ten and fourteen cents.

NEW officers of the Boise Rapid Transit Company, Boise, Ida., are: George Ainslie, president; Dwight Arnold, vice-president; George D. Ellis, treasurer; J. Spofford, secretary; George D. Ellis, general manager.

THE receiver of the street railway of Schenectady, N. Y., has filed his report with the state railroad commissioners. It shows gross earnings from operation, \$5,466.55; operating expenses, \$6,300; net deficit from operation, \$834.29.

THE Pawtuxet Valley Electric Street Railway Company, Providence, R. I., has re-elected its officers with the exception of reducing the board of directors from 11 to 5, who are: Gorham P. Pomroy; Charles H. Perkins; Marsden J. Perry; Arthur H. Watson; William G. Rolker.

THE stockholders of the Newburyport & Amesbury Street Railroad Company recently elected the following directors: Charles Odell, Thomas H. Johnson, John M. Anderson, C. H. Odell, C. C. G. Thornton and George H. Stevens. The new directors elected Charles Odell president and Ralph Calef, treasurer.

QUITE a record has been made by the two companies comprising the New England Street Railway Company, which earned the year's dividend in the eight and one-half months, ending September 15. The New Haven & West Haven earned \$152,830, an increase of \$9,230, and the Plymouth & Kingston, \$22,396, an increase of \$845.

ONE New Jersey editor has fears that the overhead trolley wires will interfere with the circulation of the air, as there are several companies after franchises in the vicinity. The poor man doesn't seem to realize that if there was such a net work, the atmosphere would be purer, for the impurities would be caught, and electricity itself is a great purifier of the atmosphere.

CONDUCTORS of the Lynn and Boston Street Railway Company have been defrauding the company. The janitor secured used tickets, which were given to passengers when conductors were changed, and sold them to the conductors for \$3 a hundred. They agreed to accept the cancelled checks, but the falling off in receipts led to exposure.

AT Chester, Pa., a car front was smashed by running into a 50-foot iron stack loaded on a wagon. The driver of the team attempted to get off the track, but the hind wheels, which were forty feet away from the horses, could not leave the tracks. The motorman saw the horses and slowed down, striking the load, which he did not see because of darkness.

THERE was a great jollification in Philadelphia September 27, when the Girard avenue line of the Philadelphia Traction Company was completed. When the car reached the Girard college, a young lady signalled the car, pressing on General Manager McIntyre a large bouquet of roses, and a card inscribed, "Welcome Rapid Transit."

THE Detroit Citizens Street Railway Company has won a decisive victory against the city of Detroit, Mich., in its appeal to the United States Court of Appeals, Judges Jackson, Lurton and Sage, having lately handed down a decision, conceding all of the points claimed by the company. The company will now construct electric lines in place of the horse cars, as the city can no longer obstruct the improvement of its lines.

THE licensing of motormen has been proposed to the city council of Providence, R. I. Advocates of licenses argue that since hack drivers and expressmen are licensed motormen ought to be, forgetting that the railway company is responsible for its employees.

A NOVEL damage suit has been brought against the Kansas City, Mo., Railway Company by Mrs. Jennie Rhoads. Her household furniture was damaged by flood one night during a heavy rainstorm. A portion of the water came from a lake at Troost Park, where the flood gates had been opened; and this park is controlled by the Kansas City Railway Company.

THE Riverside & Arlington Street Railway Company, of Riverside, Cal., permitted all persons attending school to ride free during September, and since October 1, has been selling tickets at forty-six for \$1.00. Many who rode only because it cost nothing, were loath to give up riding, and have become paying patrons.

IT is related of a conductor in a Missouri town, that when his car was crowded would say, "all you with passes stay on the back platform, those with cash please pass inside." When asked the reason for the order he replied. "The motorman gets all the money on the front platform, I get all in the inside of the car, while the company gets what is taken in on the back platform. I don't want any passes in mine, neither does my partner."

THE Syndicat de Traction par le Gaz (Syndicate of Gas Traction) has been organized in London, with a capital of £20,000, in £40 shares, to acquire certain inventions for France and the French colonies, and dependencies relating in any way to the traction or propulsion of vehicles by means of gas, and to carry on the business of mechanical engineers, machinists, gas engine makers, supplies of electricity, manufacturers of machinery and apparatus connected with the generation, storage and distribution of gas and electricity, etc. The first directors are Thomas H. Pearson, W. Clarkson and Henry P. Holt.

GERMAN electric railway business is booming. The municipal authorities of Leipsic have granted a forty years' concession for electric tramways in the town to the Allgemeine Elektrizitäts-Gesellschaft, of Berlin. It is proposed to construct at first lines to the extent of about fifteen miles, to which about six and a half miles will be subsequently added. The new lines will run alongside of the existing horse tramways, but will only use the latter's tracks at certain points. There will be seventy-five motor cars, each to carry thirty-four passengers, and about fifty trailers of the same capacity. The total estimated cost is £258,400. After considerable delays, at last it appears that the local authorities of Düsseldorf have come to an arrangement with Mr. von Tippelskirch, for the construction of an electric tramway to Grafenberg.

THE CONTI COMPRESSED AIR SYSTEM.

Experiments are being made on the Conti system of compressed air as a motive power for street cars, by the Compagnie Generale des Omnibus, Paris, France, at Nantes and at Nugent. If the preliminary trials show the system is a success, the company will build three new lines in Paris, which will be opened for traffic during the present year. The Conti system is also in experimental use in Vienna.

"In this system the air is compressed at a relatively high pressure at a central station," says Engineering, of London, from which we have reproduced the illustrations. It is then admitted into the mains B placed beneath the

Nugent tramways, which have 8¾ miles of tracks. Nine fields are at the present time being developed in the application of compressed air: distribution of power in quantities varying from the minute time pulses to motors of 150 horse power, ventilation and other sanitary purposes; refrigerators especially for the preservation of meat; manufacture of ice as a by-product of compressed air used as a motive power; elevating water and other liquids; emptying cesspools; passenger and luggage elevators; pneumatic clocks. There are 798 industrial establishments that are using compressed air for power; many workshops operating their old steam engines, the boilers being utilized as reservoirs in which the air is heated before passing to the cylinders.

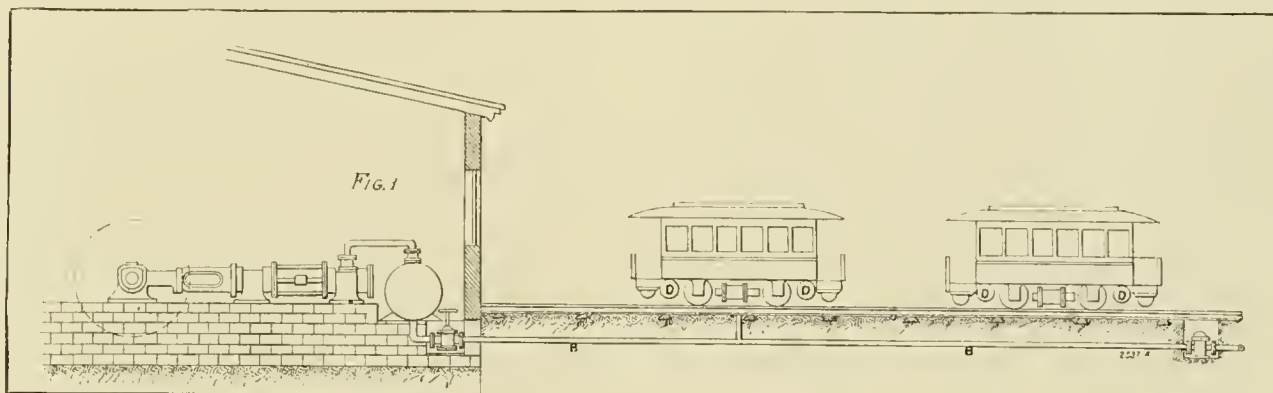

THE CONTI COMPRESSED AIR SYSTEM.—FIG. 1.

rails (Figs. 1 and 2). Branches C lead the air nearly to the surface into automatic devices by which the car reservoirs can be charged. The distance between the charging stations varies according to circumstances, but for convenience stations should be located at recognized stopping places.

An iron box is sunk into the roadway to enclose the mechanism. It is covered by a plate containing two hinged flaps, F, placed immediately over the air nozzle, E. This nozzle is the continuation of a plunger working in the cylinder E, which can be placed in connection with the air main. As the front truck of the car passes over the rails it strikes the lever G, and, depressing it, opens a valve that admits air beneath the plunger E, raises it and causes the air nozzle to push open the flaps F and rise above the level of the road. By the time it has reached its full height, the nozzle makes connection at C, communicating with reservoir D in the car. A valve is opened, which permits the compressed air to fill the reservoirs in a few seconds. The valve is then automatically closed, and as the car proceeds, the lever G is released, the air beneath the plungers in the cylinder E escapes and the nozzle falls, the flaps F closing over it, restoring the street surface. Stand pipes are provided for use in case the system should be out of order.

There are three stations in Paris intended for street railroad traction. They produce compressed air at high pressure, representing about 13,000 horse-power. An application of the McKarski system is made on the

COMPRESSED AIR AT WESTFIELD.

On the street railway tracks at Westfield, Mass., there has been operating, for the past ten weeks, a car propelled by compressed air. The demonstration has been

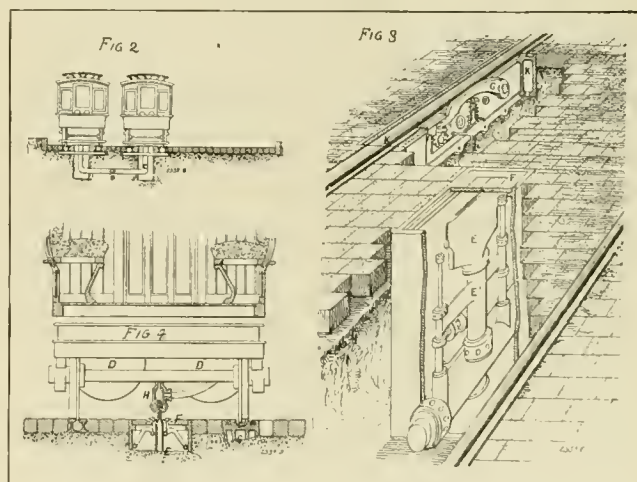

THE CONTI COMPRESSED AIR SYSTEM.—FIGS. 2, 3 AND 4.

conducted by J. F. Lewis, of the Rand Drill Company, New York, and we are advised the experiment has met with strong approval of the riding public, and has proved economical in fuel and repairs. The car has been in regular, full term daily service and has recently completed 18,000 miles of service, carrying 63,000 passengers at a cost per car mile of less than 12½ cents.

## STREET RAILWAY LAW.

EDITED BY FRANK HUMBOLDT CLARK, ATTORNEY AT LAW, CHICAGO.

*Injuries Inflicted by Fellow Passengers.*

The failure of a street car company to expel an intoxicated man from its car does not render it liable for an injury inflicted by him upon a fellow passenger, where the intoxicated man has not been demeaning himself in such a manner as to forfeit his legal right to ride.

This suit was for the recovery of damages for injury to plaintiff's foot. The injury was by being trodden upon by a passenger who was standing in the same car where the plaintiff was seated. The plaintiff entered the car at the City Hall Station, and after it started she noticed a man in a state of intoxication standing in the aisle holding on to a strap, nearly in front of her. After the man had been in that position some time he lurched and stepped on the plaintiff's foot. He was holding on to the strap and lurching at every turn. Some ladies appeared to be frightened, but neither they nor the plaintiff made any special manifestations of their fear. A passenger called the attention of the guard to the intoxicated man, and suggested that he be put off or found a seat; and made some other suggestions, but he was not removed.

At the trial, when the plaintiff rested her case, the trial judge dismissed the complaint. The question is whether the testimony introduced on the part of the plaintiff was sufficient to carry the cause to the jury. There is no legal principle which imposes liability upon a carrier of passengers for the wrongful acts of the passenger; but because such carriers have the right to refuse passage to one who is drunk or disorderly, and to expel him after he has been received, if he so conducts himself as to be dangerous to other passengers, or interfere with their comfort, and it is their duty to expel persons who imperil the safety or annoy their fellow passengers, they may become responsible for injuries inflicted or resulting as a consequence of such negligence. Yet, it must be borne in mind that all passengers have the same legal rights, of which they cannot be deprived until they are forfeited by their misconduct. A man in a state of inebriety has a legal right to ride in a public conveyance. So long as he remains quiet and molests no one he cannot be legally expelled. It is only when he becomes dangerous or annoying to other passengers that he becomes liable to expulsion.

There is no claim that the injury to the plaintiff was intentional, and we detect no misconduct on his part that would have justified his expulsion from the car. We also find the evidence entirely insufficient to charge the guard with any neglect of duty which the law imposed upon him. It is true that his attention was called to the man, but he neither saw nor received information of any impropriety, nor anything to indicate a disturbance.

It follows that we find no cause of action.

(Supreme Court of New York. *Thompson vs. Man-*

*hattan Railway Company.* 27 New York Supplement 608.)

*Injury to Passenger—Proximate Cause—Passenger Jumping from Moving Car.*

Two acts of negligence are charged in the declaration, viz: That defendant's driver failed to stop its car, as requested, at the intersection of Addison street and Evanston avenue; and that the deceased, while with due care and diligence endeavoring to alight from the car, was thrown to the ground and injured by reason of the negligence of appellant in failing to properly equip its cars with safety guards and appliances.

As to the alleged negligence in failing to stop its car when requested the Court is unitedly of the opinion that no recovery can be had in this case. For whatever damage a passenger may sustain from the failure to stop a street car at a proper place when properly requested, such failure being the proximate cause of the injury, a recovery might be had.

In the present case, between the negligence of the driver, and the injury to the plaintiff's intestate, there intervened another cause without which the accident would not have happened; that intervening cause was the act of the deceased in jumping from the car while it was in motion.

The train of events, from the failure to stop the car to the accident, was not a natural or necessary sequence from the act of the driver in not stopping his car; nor was the jumping from the car, so far as is shown by the evidence, a thing which the defendant can be presumed to have known would follow the failure to stop.

(Appellate Court of Illinois. *North Chicago Street Railway Company vs. Wrixon.* 51 Illinois Appellate, 307.)

*Injury to Person Crossing Street—Rate of Speed—Negligence.*

Street cars propelled by electricity and running along land burdened only with the easement of a public highway, cannot be run at a rate of speed incompatible with the lawful and customary use of the highway by others with reasonable safety.

The rule requiring one exercising his lawful rights in a place where the exercise of lawful rights by others may put him in peril, to use such precaution and care for his safety as a reasonably prudent man would use under the circumstances, is the measure of duty for one who crosses a public highway on foot. He must use his powers of observation to discover approaching vehicles, and his judgment how and when to cross without collision: but his observation need not extend beyond the distance within which vehicles moving at lawful speed would endanger him. If obstacles temporarily intervene to prevent observation, he should wait until the required observation can be made.

(New Jersey Court of Errors and Appeals. *Newark Passenger Railway Company vs. Block.* 27 Atlantic Reporter 1067.)

*Rights of Street Railway in Street—Consent of Abutting Property Owners—Agreement Contrary to Public Policy.*

When the property of an abutting owner is damaged by the construction of a horse railroad in front of his premises, he is, under the provisions of the Constitution, entitled to compensation. Thinking that such construction would be a damage to him, he has a right, before and as a condition of giving his consent to the laying of such tracks, to bargain and sell the right to damage his property, for the largest sum he can obtain.

Where an obligation provided that if the obligor would "violate the conditions of this obligation the sum of one hundred thousand dollars shall thereupon become due and payable to the said obligee, \* \* \* as liquidated damages therein," etc., it was held that the sum nominated was not in law liquidated damages, but merely a penalty.

A street railroad company cannot, by a contract with an individual, limit the sphere of its action and contract that it will not in the future do that which the public interests may demand.

The Chicago City Railway entered into an obligation "that it will not hereafter build, construct or lay, any other or more than a single track railway without switch or switches, turnout or turnouts, along any part of Wabash avenue, between Lake street and the north line of Madison street." *Held*, that the obligation was without binding force, as it was in effect a contract not to do that which, in the future, the public interests might demand.

(Appellate Court of Illinois. *Doane v. Chicago City Railway Company*. 51 Illinois Appellate 353.)

*Obstruction Near Track—Elevated Railroad Pillar—Injury to Person on Step of Street Car.*

The plaintiff, with some friends, boarded an open summer car of the defendant, having steps running along upon the outside. The plaintiff stood for a time on the rear platform smoking. As the car neared Forty-Second street some people got out and the plaintiff undertook to proceed along the side step to occupy one of the seats vacated. The change was voluntary on his part, and while he was attempting to consummate it his head was brought in contact with an elevated railroad column and badly injured. At the trial the complaint was dismissed, and we think the dismissal was right. The defendant was guilty of no act of negligence, and did nothing by means of which the plaintiff was injured. The defendant was not responsible for the presence of the elevated railroad columns, nor for any injuries caused by them.

(City Court of New York. *Vroman vs. Houston W. St. & P. F. R. Co.* 27 New York Supplement, 257.)

*Injury to Person in Street—Wagon Beside Track—Care of Motorman.*

So long as a common user of streets exists in the public it is the duty of street railway companies to exercise such watchful care as will prevent accidents or injuries to persons who, without negligence on their own part may not at the moment be able to get out of the way of a passing car. The degree of care to be exercised must necessarily vary with the circumstances of each case.

In an action against a street railroad company for personal injuries, plaintiff, the driver of a delivery wagon, testified that he drove his wagon close to the curb because he knew the street was so narrow as to render it difficult for cars to pass teams; that after making the delivery he noticed an approaching car, and went to the

rear of the wagon to shut up the tail board; that he signalled the motorneer to stop, and started to unhitch the horse to get him out of the way of the car, and that, while unhitching, the car struck the end of the wagon, frightening the horse, which turned around and injured plaintiff. *Held*, sufficient evidence of negligence on defendant's part to warrant the submission of the case to the jury.

(Supreme Court of Pennsylvania. *Kestner v. Pittsburg & B. Traction Co.* 27 Atlantic Reporter 1,048.)

*Street Railway—Paving Streets—Raising Track to Grade.*

A borough, in 1886, granted a street railway company a franchise of certain streets, the company to keep them in repair between and a foot outside its rails, to construct its road in accordance with the grades, and, in case of change of grade or improvement, to change said railway to conform thereto, as per notice from the borough engineer, at the company's expense. The company accepted, and built on the borough's principal street, which had been macadamized some eight or ten years before. The street being about worn out, and the borough and its traffic having largely increased, in 1890 the council determined to pave the street with Belgian blocks. *Held*, a reasonable and proper repair, to which the company was bound to conform its part of the street.

When a street railway company contracts, in case of a change of grade or improvement, to change its "railway" to conform thereto, it does not conform to a change of grade by digging trenches for its rails to the new grade, leaving the space between unexcavated.

(Supreme Court of Pennsylvania. *Borough of McKeesport v. McKeesport Passenger Ry. Co.* 27 Atlantic Reporter, 1,006.)

*Unguarded Excavation—Injury to Person Traveling in Street—Liability of Street Car Company.*

Plaintiff was injured by the wheels of her wagon getting into an excavation made by the removal of the cobblestones on a turnpike road, between the rails of defendant street railroad company. The excavation was near a bridge which the turnpike company was raising, and, at the time of the accident, was unguarded and unlighted. It is no doubt true that it was competent for defendant company to show that the injury complained of was due to the negligence of others; but, unfortunately for it, there was evidence that the repairs out of which the injury grew were under the immediate charge of its officers, while the railway was in actual operation by the company. The public had a right, and, it appears, was accustomed to use the tracks in common with defendant; and if the track was put in such a condition as to render dangerous public travel it was the duty of those having charge to give adequate warning. The judgment is affirmed.

(Supreme Court of Pennsylvania. *Wagner v. Pittsburg & W. E. Pass Ry. Co.* 27 Atlantic Reporter, 1,008.)

### THE CLEVELAND CITY RAILWAY PALACE CAR.

The new palace car of the Cleveland City Railway is shown in the accompanying engravings, by courtesy of Secretary J. B. Hanna, of that line.

The car is of 16-foot body, with a width of 7 feet 6 inches to swell of panel. It has four windows on the side and two narrow ones in front, with a beveled looking glass between. There is no access from the front

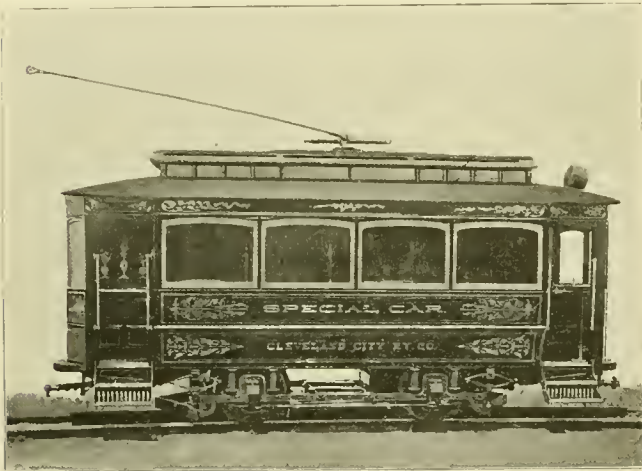

PALACE STREET CAR.

end. All the window glass is beveled plate and the ventilators of green chipped glass. The ventilators, which are along either side and at each end, are attached to a metal rod and move ensemble.

The entire interior of the car, including the ceiling, is laid with white mahogany, rubbed off in oil and decorated by a Cleveland artist of national reputation. The carpet on the floor is green wilton and the sofas and cushions of green corduroy, matching the glass and carpet. The sofa, which extends across the front end, and twelve rattan chairs, make the guests comfortable. All of the metal work, including the grab handles, light-pendants, brake wheels and controller top, are of nickel plate. Ten lights are aboard the car, the forward and rear four being enclosed in two large greenish tinted bowls, and the headlight forward is of the electric style. Electric call bells are used throughout, for signaling both the motorman and conductor.

One-half of the rear platform is thrown into the car, making an alcove, a pretty and useful idea. This alcove is furnished with a pendant lamp. Two steps instead of one are furnished the guests of the road to mount this beautiful car.

The truck in use is furnished with patent cushioned wheels, made by the company. It is an ordinary wheel with a steel tire on the outside, with springs in between to relieve the jar, as well as to deaden the sound of the running gear. One single reduction Westinghouse motor drives this beautiful effort of the car builders' art.

Mr. Hanna was the designer of the interior decoration

and furnishings of the car, while Superintendent G. C. Mulhern arranged the running gear. So rich is the car in its decoration and equipment that many newspapers have refused to believe it. If our engravings, from photographs, do not prove the story, Mr. Hanna invites all doubters to go down to Cleveland and take a ride.

### ANOTHER FALSE REPORT FROM THE DEADLY TROLLEY.

Some time ago a report came from Butte, Montana, that a boy had died from the effects of a shock received from the trolley of the Butte Consolidated Railway. On investigation the affair proves to be another of those unfortunate cases in which death resulted from the effects of a fall caused by the shock and not by the shock itself. Injuries from this cause are far more frequent than those the result of the shock alone. The circumstances of the case in question were most peculiar and it almost amounted to suicide. At the place it occurred the street railway passes under a steam railroad trestle. Alongside of and at the same height as the trestle, was a flume with several inches of water in it. The trolley wire was suspended from the trestle and flume. The boy was wading in the water in the flume and threw a wire which he held in his hand over the trolley wire. He was warned by his companions to look out, but took no heed. The shock knocked him down, and he fell 15 feet on to the street railway tracks below, striking on his head. He was undoubtedly killed by the fall rather than by the shock, as the resistance of the water in the flume must have been considerable. This business of small boys playing with electric wires is getting entirely too common. It is impossible to get wires beyond the reach of those who are determined to get at them, and the only remedy seems to be an application of the parental slipper. The Consolidated was exonerated of all blame in this case.



INTERIOR—PALACE STREET CAR.

NEW PLANT OF THE CHICAGO GENERAL RAILWAY.

The most important electric railway work being done in Chicago this fall, exclusive of the changing over from horses to electricity of the three great systems which have held sway on the north, west and south sides for many years, is the new plant of the Chicago General Railway, a company that has extensive franchises in the

southwest part of the city and which has been operating four miles of line on west Twenty-second street for over a year. The line now running has proved to be a remarkably paying one as was noted in a previous issue of the REVIEW. It is simply a crosstown line and has no downtown connection as yet. The traffic is at present restricted by the limited output of a temporary power plant. With the erection of the power house and car barns here described and the building of several more

CAR HOUSE, REPAIR SHOPS AND POWER PLANT OF THE CHICAGO GENERAL RAILWAY CO.

DESIGNED BY C.L. BONNEY V.P.

----- = STEAM R. R. TRACK CENTERS  
 ————— = STREET RY. TRACK CENTERS

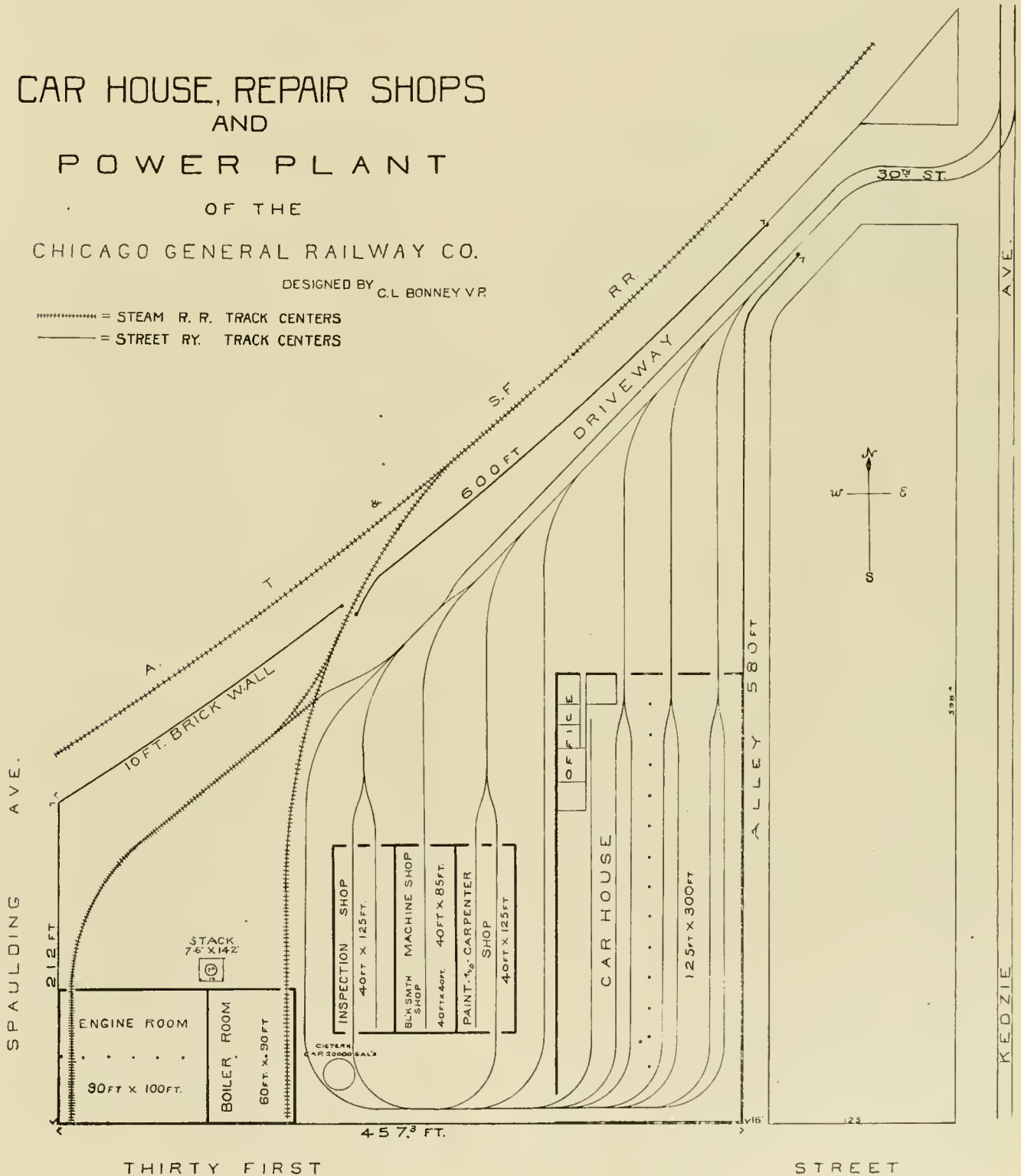

THIRTY FIRST

STREET

miles of line for which franchises have been granted, the road will at once take a place as one of the important systems of Chicago. The buildings are now almost completed.

The site chosen was on the corner of Thirty-first street and Kedzie avenue a location nearly central to the territory to be served and at the same time one which did not necessitate any expensive crowding of power station or car barns. The lot is bounded on the east by Kedzie avenue, on the south by Thirty-first street, and on the north diagonally by a branch of the Santa Fe Railroad. The Chicago river is but a short distance to the

The plans are so drawn that enlargements can be made to utilize every foot of ground to good advantage without tearing down work already put in. The power house, located in the southwest corner of the lot, can be extended north toward the railroad tracks, so as to more than double its present planned maximum capacity with a uniform arrangement throughout. The car barn can be extended east 125 feet to the boundary of the lot, and the inspection, machine, carpenter and paint shops can be extended north. As the road demands it, more tracks will be put in the barn. This provision for extensions is the only sound policy for a growing road to pursue.

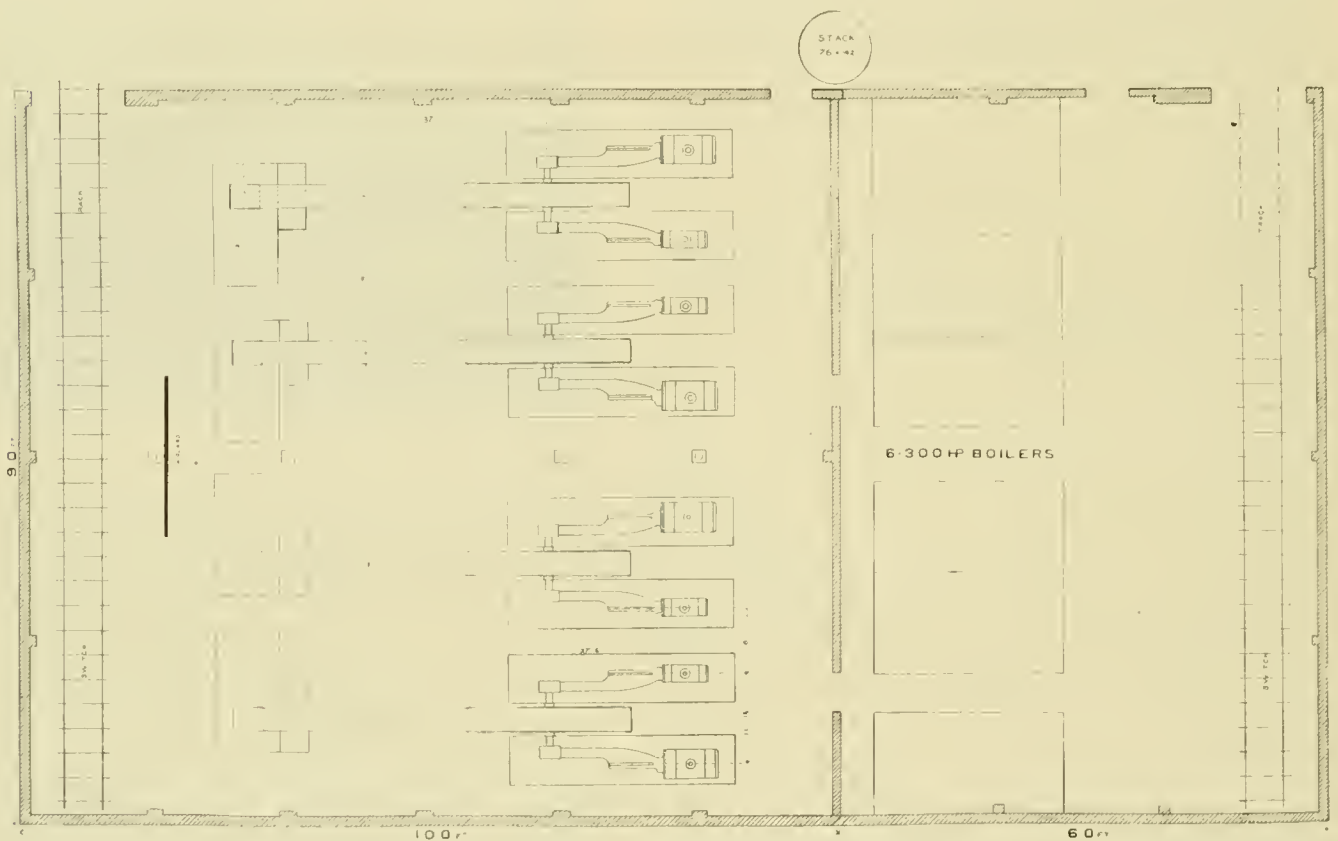

PLAN OF POWER STATION—CHICAGO GENERAL RAILWAY.

south so that water is at hand for condensing. Thus the location is about all that could be desired. The lot having been secured, C. L. Bonney, the vice-president of the company, who has planned the installation and has charge of the construction work, announced a prize contest for a set of plans to cover a complete street railway plant to be located on this lot, the idea being to get a stock of ideas from which to choose. The contest was decided about August 1, and the results as announced in the August REVIEW are known to our readers. The plant as finally arranged by Mr. Bonney, and as now being installed, contains a number of valuable ideas obtained from the various contestants and combined in a rather unique way. The plans will be found worth study, as some radical departures from common practice have been made, not however without due deliberation and good reasons for such action,

The size of the lot is much in excess of present needs, but as the street railway business goes in this country it will be outgrown much before the owners of the road expect.

The plant is surrounded by a brick wall 10 feet high. While this is not expected to keep out people who are determined to climb over, it is calculated to prevent petty annoyances, especially in times of strikes. There are only two entrances to the grounds, one at the steam railroad switch track and the other where the street railway tracks come in from Kedzie avenue, at the northeast corner of the lot. A peculiar feature of the arrangement is that there is no switching done in the street, all the special work being inside the yard. This arrangement would not be practicable in some places, but it must be remembered that the location is in a thinly settled district where land is plenty and the streets are not



yet brought to grade. Aside from this, the advantage of having the special work above the surface, where so much of it is necessary, as in this case, is considerable. It cannot be denied that the arrangement of tracks is convenient and conducive to economical operation. The steam road tracks run into the boiler room and also into the engine room. When the station is completed, a traveling crane will be supplied for each half of the engine room, one rail being supported by the center line of pillars and the other by the outer wall. There is a connection between the steam and street railway tracks near the yard entrance which has proved a great convenience in construction, and will no doubt be the same in future years.

A car on entering the yard may go directly into the barn or be run into the inspection shop. From the inspection shop it can either be taken into the rear of the barn or run up alongside of the barn and back to the street. There are two distinct and complete loops for cars to go around inside the yard and buildings. A little study will show how convenient the arrangement is.

The power station is arranged for four engine and dynamo units, of 450-horse-power each, one of which is now being installed. The generator chosen is a 300-kilowatt General Electric, and the engine the 450-horse power tandem compound condensing corliss, made by the Bates Machine Company. Root boilers will be used, and coal will be unloaded from the cars directly in front of them, so that fuel will not have to be handled twice. The brick stack, 142 feet high, is slightly separated from the building.

The idea has been to centralize everything into one yard, and provide the centralized plant with every convenience for economical operation. The arrangement is one that certainly ought to give good results, and one in which Mr. Bonney may justly take much pride.

#### CAR FENDER HUMOR.

"But your car fender is entirely too light and fragile," said the president of the street car railway to the inventor, "I don't believe the fender could stand the slightest resistance without breaking—"

"That's its chief merit," interrupted the inventor, "it breaks easily. If a person is struck by the fender it is sure to break, and then the company can have the person struck arrested for malicious mischief, prosecuted for trespassing and bring suit for damages. This will worry the injured person so that he will be glad to compromise matters, and the company will be saved a great many heavy damage suits."

H. C. BRUNER, the extensive brickmaker of Pontiac, Ills., has sold to the Chicago City Railway, 350,000 brick liners, or fillers, which he will make to their special order. The fillers can be used in paving to any section of T or girder rail, and this is the largest order of the kind ever placed.

#### TWO NEW SPECIALTIES.

The Ohio Brass Company, Mansfield, O., has brought out two new specialties, which have been added to its line of material. One is the Jewell trolley sling and the other an adjustable and reversible track brush holder.

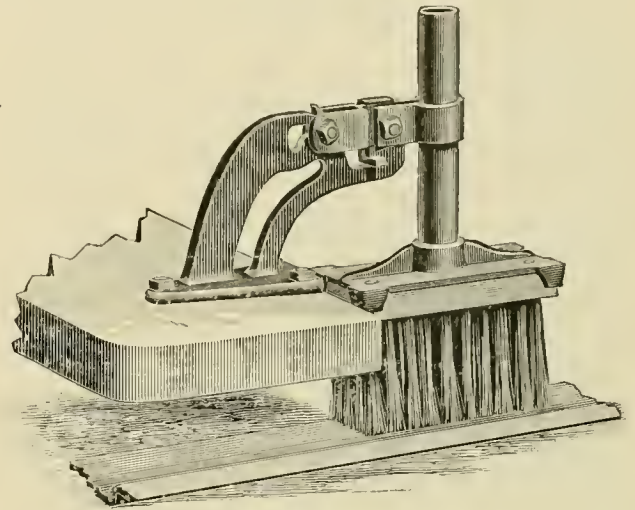

ADJUSTABLE TRACK BRUSH HOLDER.

Both of these devices were shown at the Atlanta convention, attracting considerable attention. They have been thoroughly tested and large sales are reported. The Ohio Brass Company reports a satisfactory trade with a constantly increasing number of orders.

#### WAGES OF CONDUCTORS AND DRIVERS IN EUROPE.

A traveler returning from Europe gives some statistics regarding wages, which he had gathered merely to gratify his own curiosity. He found that in Constantinople street car drivers were paid forty cents a day, conductors, seventy-five cents a day. In Florence, Italy, street car drivers received fifty cents and conductors seventy-five cents a day. In Naples the drivers and conductors were on an equal footing, receiving fifty cents a day. In Athens, Greece, the daily stipend of both drivers and conductors is also fifty cents. In Algiers, Africa, the men receive a trifle more, drivers getting sixty cents and conductors eighty cents per day. The omnibus driver in London is paid \$1.50 for twelve hours' work. Many of the omnibus drivers labor fourteen to sixteen hours daily.

#### HAS A REAL GRIEVANCE.

Eben Rathbone of Westerly, R. I., has a grievance against the electric road there. For many years past he has salted a barrel of skunks every fall, for winter use. During the past few weeks the electric cars have wrought such destruction among those animals that he fears he will have to resort to other means of sustenance.

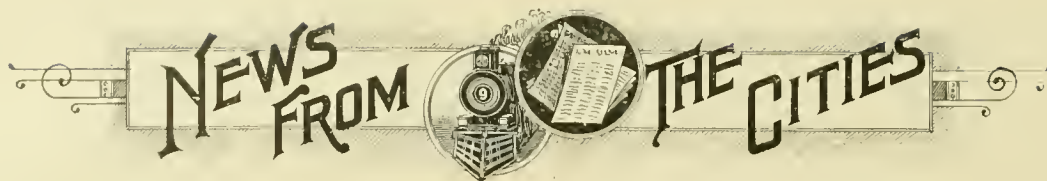

### Alabama.

ANNISTON, ALA.—It is reported that the Anniston Street Railway has suspended operation.

### Arizona.

PHOENIX, ARIZ.—Messrs. Kittridge, Hedges and Dobson, real estate men, are projecting an electric road to Montgomery's addition.

### Arkansas.

TEXARKANA, ARK.—The Texarkana Car & Foundry Company has assigned to P. A. Turner.

### California.

SAN FRANCISCO, CAL.—The Market Street Railway Company will make several extensions.

SAN FRANCISCO, CAL.—The Phelps Manufacturing Company, makers of cable road iron work, has failed.

BERKLEY, CAL.—The street car line to West Berkley will be equipped with electricity. It will be a \$60,000 job.

PASADENA, CAL.—The Los Angeles & Pasadena Electric Railway has purchased the Highland Electric Railway of Pasadena for \$18,000.

PASADENA, CAL.—The Los Angeles & Pasadena Electric Railway Company has been granted a franchise for 50 years, which will be sold to the highest bidder.

PASADENA, CAL.—Prof. C. C. Lowe has returned from Chicago, where he closed a deal to build an electric extension of the mountain road, seven miles from Echo mountain to Mt. Lowe.

BERKLEY, CAL.—The town trustees have ordered a street railway franchise advertised, at the request of the West Berkeley & Perlata Park street car line, which will be equipped with electricity.

OAKLAND, CAL.—The receiver of the Piedmont Consolidated Cable Company has filed a petition in court asking permission to change the cable road over the hills into an electric road. He also wants to borrow \$32,000 to pay debts and make improvements.

### Canada

PORT HOPE, ONT.—P. R. Randall says work will be begun on the electric railway in the spring.

TORONTO, CAN.—The Toronto Railway Company will build a brick car shed costing \$20,000, and will place vestibules on all cars.

MONTREAL, CAN.—The Montreal Park & Island Railway Company will extend its electric line to Notre Dame de Grace and Lachine, and will resume work on other extensions.

TORONTO, ONT.—York township has voted a bonus of \$5,000 to the City & Suburban Street Railway Company, for the purpose of extending its line from Toronto Junction to Weston.

PRESTON, ONT.—The Preston & Berlin Street Railway Company has decided to construct an electric road to Berlin. John Fennell and T. M. Burt, of Berlin, are the principal promoters.

OTTAWA, ONT.—The town council of Aylmer has made a bargain with Theophile Viau, Hull, to operate an electric railway system. At least \$10,000 worth of work must be done the first year.

HAMILTON, ONT.—The Hamilton Electric Radial Railway Company has bought the Niagara Central Railway, a steam road from Niagara Falls to St. Catharines. The consideration is reported \$400,000. The new road will be extended to Hamilton to connect with the radial road.

QUEBEC, CANADA.—The Quebec City & District Railway Company will be incorporated by L. P. Peletier, of Quebec, Philippe Landry, of Ville Mastai, J. J. T. Fremont, P. B. Dumoulin, Bernard Leonard, John U. Gregory and Ernest Pacaud, all of Quebec, to build lines in Quebec and adjoining counties.

HULL, ONT.—The men interested in the road here are: Theophile Viau, contractor, Hull; J. P. Demartigny, manager, Banque; Jacques Cartier, Hull; Stanislaus Aubry, father of Dr. Aubry, who is mayor of Hull; J. M. McDougall, Q. C., of Hull, and W. J. Poupore, contractor, of Morrisburgh. The capital of the company will be \$25,000.

### Chicago.

CHICAGO.—Fernwood property owners are securing consents for an extension of the Calumet Electric.

CHICAGO.—The Metropolitan "L" has taken out a permit for a two-story and basement brick repair shops, to cost \$30,000.

CHICAGO.—The North Chicago Street Railway Company has secured control of the Chicago & North Shore Railway Company.

CHICAGO.—The Chicago City Railway is securing the consent of the property owners along Lake avenue for a trolley line along that street.

CHICAGO.—The Calumet Electric Street Railway Company has an ordinance before the city council for an extension of about three miles in South Chicago.

CHICAGO.—The Carter Brake Company has been incorporated with \$2,000,000 capital by Samuel C. Carter, Robert E. Lindgerwood and Clarence W. Carter.

CHICAGO.—B. J. Jones, formerly of Sioux City, Iowa, has been elected superintendent of the South Chicago City Railway, to fill the resignation of R. D. Rowe.

CHICAGO.—Ald. Kleinecke introduced an ordinance for the Chicago Electric Transit Company to operate in the northwestern portion of the city, with the right to connect with other lines.

CHICAGO.—O. W. Bruner, president of the Chicago Inter-Urban Street Railroad Company, has given notice by publication that the company will ask the Cicero town board for a franchise.

CHICAGO.—The Ogden Street Railway Company, E. A. Cummings, president, is asking for an electric railway franchise in the town of Cicero. Charles T. Yerkes is supposed to be back of the company.

CHICAGO.—Contract has been awarded for erecting the new electric power house of the West Chicago Street Railroad Company to L. L. Leach & Sons. The building will be 126x250 feet and cost \$150,000.

CHICAGO.—The Columbia Construction Company, which has the contract for building the Northwestern Elevated Railroad, has called for a third installment of 25 per cent of its capital stock.

CHICAGO.—The Cook County Electric Railway Light & Power Company has been incorporated with \$500,000 capital by Clarence N. Durand, 813 Chamber of Commerce, Abner T. Young and Charles Greenwood.

**CHICAGO.**—The Chicago Suburban Rapid Transit Company has asked the board of county commissioners for an electric road franchise, beginning at Fullerton avenue and Seventy-second street, to Desplaines, with a branch to the town of Maine.

**CHICAGO.**—It is reported in stock exchange circles that the North Chicago Street Railway Company will issue \$1,000,000 additional capital stock January 1, to be divided among the stockholders at par. The proceeds will be used for electrical construction.

**CHICAGO.**—Edward Koch has been elected president of the North Chicago Electric Railroad Company in place of D. H. Loudebach. It is said that right of way is being secured for an electric line twenty miles long with a loop in South Water, River, Rush streets and Michigan avenue, with a terminus at Norwood Park.

**CHICAGO.**—It is said that R. B. Campbell, general manager, Baltimore & Ohio Railroad; President Baker, of the Trust & Savings Company, and Mr. Selden, Baltimore; J. W. Fortune, assistant general manager, Grand Trunk Railway, and A. J. Green, Windsor, Ont., are negotiating for the purchase of the Joliet Street Railway Company, Economy Light & Power Company and Joliet Gas Works, and extend the line to Chicago.

## Colorado.

**COLORADO SPRINGS, COL.**—The officials of the Denver & Rio Grande Railroad Company are considering a proposition to equip the Manitou branch with an overhead electric system.

## Connecticut.

**NEW LONDON, CONN.**—The New London Street Railway Company will make improvements.

**FAIRFIELD, CONN.**—The Bridgeport Traction Company has been granted a franchise for a single track.

**ROCKVILLE, CONN.**—The Rockville & Ellington Electric Tramway Company wants to build its line beyond Talcottville.

**NORWALK, CONN.**—The Norwalk Tramway Company has been given permission to extend its electric lines to Dorlon's Point. The cost is estimated at \$30,000.

**HARTFORD, CONN.**—Judge Robinson has decided that an electric line to South Windsor is a public necessity, and the Hartford Street Railway Company will build. The case has been in the courts for some time.

**SOUTHINGTON, CONN.**—L. V. Walkley, New York, who has bought the controlling interest in the Southington & Plantsville Electric road, is negotiating with the New Britain folks and with the Meriden Electric Company, to extend their lines to Southington.

## District of Columbia.

**WASHINGTON, D. C.**—The stockholders of the Metropolitan Railway have voted to issue bonds to the amount of \$1,700,000, for equipping with an underground conduit system.

## Florida.

**JACKSONVILLE, FLA.**—E. M. Holmes says that financial matters are fixed all right for the electric railway.

**TAMPA, FLA.**—R. W. Easley and W. H. Kendrick propose to build an electric street railway to Palmetto Beach.

**DELAND, FLA.**—J. B. Stetson contemplates building an electric rail way from DeLand Junction to Orange Park, via DeLand.

**JACKSONVILLE, FLA.**—George W. Haines, superintendent of the Jacksonville Street Railroad Company, says that an extension is being arranged out to West Campbelltown, West Louisville and West Brooklyn.

## Georgia.

**SAVANNAH, GA.**—As a result of the war of competition between the street railways, it is rumored that the Electric Railway Company and the Savannah Street Railway Company will be reorganized.

## Illinois.

**LASALLE, ILL.**—The City electric line will extend its upper and lower lines.

**PERU, ILL.**—An ordinance has been passed giving franchises to the City Electric Railway Company.

**DIXON, ILL.**—The Rock River Electric Railroad has accepted the Dixon, Oregon, and Byron franchises.

**MT. CLEMONS.**—The council has granted a franchise to B. B. Cousins and others, to build a road here within a year.

**CINCINNATI, O.**—The Cincinnati Street Railway Company will build a power house 150 by 180 feet, designed by Bert Baldwin.

**BLOOMINGTON, ILL.**—W. H. Patterson, who has bought the Lincoln, Ill., line, will lay a mile of new track and make a belt line.

**PEORIA, ILL.**—The stockholders of the Peoria Heights Street Car Line Company decided to complete the line early in the spring.

**PEORIA, ILL.**—The Pekin & Peoria Electric Railway Company is selecting its route between the two cities. Edward Darst has the matter in charge.

**SPRINGFIELD, ILL.**—The Capital Electric Company has been incorporated, with \$60,000 capital, by John McCreery, Peter W. Harts, Fred D. Buck, George Pasfield, and Edwin A. Wilson, all of this city.

**JOLIET, ILL.**—R. B. Campbell, general manager of the Baltimore & Ohio, J. W. Fortune, assistant general manager of the Grand Trunk, and A. J. Green, are here, and it is reported will buy the Joliet Street Railway, the Economy Light & Power Company, and the gas works. There is talk of extending the electric road from Lockport to Chicago. The Joliet system will be overhauled.

## Indiana.

**LAFORTE, IND.**—An electric street railway is to be built with an extension to Michigan City, by P. J. Henson, of Chicago.

**INDIANAPOLIS, IND.**—The Indianapolis & Broad Ripple Rapid Transit Company has bought a lot and will build a two-story office building and car barn, and in time, a power station.

**SOUTH BEND, IND.**—Franchise has been granted the General Power & Quick Transit Company, J. Mc M. Smith, president, for a line to Mishawaka. Mr. Smith says he will get to work in the spring.

**HAMMOND, IND.**—The Hammond, Whiting & East Chicago Electric Railway Company will build a four mile extension to Robey, making a direct connection. A summer resort will be created at Lake George.

**TERRE HAUTE, IND.**—Stockholders of the recently organized Terre Haute & Brazil Electric Railway Company have elected the following directors: Major Collins, of Brazil; S. N. Hickman, W. H. White, C. F. Miller, R. J. Smith, Max Joseph and J. G. Elder.

## Iowa.

**DES MOINES, IA.**—The Des Moines City Railway Company will build an extension.

**BURLINGTON, IA.**—The Burlington Electric Railway Company will extend its lines to West Burlington.

**COUNCIL BLUFFS, IA.**—S. P. McConnell has sold his interest in the Lake Manawa Railway Company to J. C. Shaffer.

INDEPENDENCE, IA.—A. C. Rowe, late of Minneapolis, has been appointed superintendent of the Independence Electric Street Railroad Company, in place of A. D. Guernsey.

FT. MADISON, IA.—It is reported that interested parties have been looking over the field for an electric line to Nauvoo, the Mormon settlement, which is said to be exceptionally good.

### Kansas.

LEAVENWORTH, KAN.—The Leavenworth electric railway has surveyed a route to Lansing, and will extend to that place at once.

ATCHISON, KAS.—Topeka and St. Joseph parties are figuring on an electric line to St. Joseph, touching Wathena, Troy, Doniphan and Brenner.

INDEPENDENCE, KANS.—The Farmers' & Merchants' Suburban Railroad Company & Fair Association has been incorporated to build and operate a line of street railway from Independence to Petroleum Park, with branches to Cherryvale, Coffeyville, Liberty and Neodesha. Capital stock, \$200,000; incorporators, M. J. Paul, M. F. Wood, Edwin Foster, J. H. Brewster, Joseph Chandler, O. P. Ergenbright and J. W. Wright, of Independence.

### Kentucky.

GEORGETOWN, KY.—The street car stable was burned on the night of October 19. One car was destroyed. Loss, \$1,500.

HENDERSON, KY.—Benjamin Allsop, Owensboro is negotiating for the purchase of the Henderson Street Railway Company by the Owensboro City Railway Company. If the deal is consummated, the line will be equipped with electricity.

### Louisiana.

NEW ORLEANS, LA.—It is reported that enough stockholders have been won over to assure the substitution of electricity on the Orleans Street Railway Company.

### Maryland.

BALTIMORE, MD.—The Baltimore Traction Company will change its Gilmore street line from cable to electric power. President Brown expects a saving of \$20,000 annually by the change. A 500 horse-power generator will be purchased.

BALTIMORE, MD.—President Nelson Perin has sold 5,000 shares of the City & Suburban Railway Company to John A. Whitridge, John W. Hall, Alexander Shaw and Jenkins Brothers. The price paid was \$42.50, par value being \$50. Mr. Perin still retains a controlling interest.

BALTIMORE, MD.—The Clifton Park Passenger Railway Company has been incorporated, with a capital of \$50,000, by W. J. Taylor receiver of the Baltimore & Lehigh Railroad, Alfred J. Ulman, Jas. H. Smith, Davies Murdoch, Frank N. Hoen, Roberts S. Carswell, and Eben B. Hunting, all well known men.

### Massachusetts.

PLYMOUTH, MASS.—Albert L. Gordon has been elected president of the Plymouth & Kingston Street Railway.

MEDFORD, MASS.—Property owners made no objection to the proposed franchise of the West End Street Railway Company.

BOSTON, MASS.—The West End Street Railway Company has bought property at Dorchester, on which a large car house will be built.

NORTHAMPTON, MASS.—An extension of the Northampton Street Railway Company to Eastampton will probably soon be made.

WESTFIELD, MASS.—The selectmen have given the Highland Street Railway Company permission to use the tracks and turnouts of the Woronoco Street Railway Company.

LOWELL, MASS.—The Lowell, Lawrence & Haverhill Electric Railroad Company has asked for a location for its entrance into the city. The road must be built by April 29, 1895.

BOSTON.—The Fall River & Providence Street Railway Company, backed by F. S. Stevens, R. T. Davis, Frank Brightman, and Benjamin Cook, will ask the legislature for a franchise.

BOSTON, MASS.—The Board of Railroad Commissioners has given permission to the Natick & Cochituate Street Railway Company to issue \$28,000 additional capital stock to pay for extensions.

BRAINTREE, MASS.—The Weymouth & Braintree Street Railway Company has been formed to build an electric line between the two towns, each of them having granted the necessary franchise.

NEW BEDFORD, MASS.—The Union Street Railway Company has been sold to a syndicate represented by J. A. Beauvis. Electricity will be used. Edward N. Gibbs, N. Beckley, Frank W. Brightman, Frank S. Stevens, George H. Hawes and Charles F. Shaw.

MARLBORO, MASS.—A company has been organized by J. O. Burdett A. M. Bridgman, L. V. Price, E. B. Harvey, E. C. Bates, W. C. Blake and W. D. Burdett, to build a street railway to Westboro via Southboro, a distance of seven miles. Capital stock, \$100,000. The heaviest subscriber is G. M. Jewett, trustee, New York.

### Michigan.

DETROIT, MICH.—The Citizens' Street Railway Company is considering the extension of its tracks on Russell street.

SAGINAW, MICH.—The line between here and Bay City will be built next spring by the Saginaw Union and the Bay Cities Consolidated.

PORT HURON, MICH.—The Port Huron Street Railway Company has been granted a six months' extension to build its Lapeer avenue line.

BATTLE CREEK, MICH.—The Citizens Street Railway wants bids for equipping six motor cars and other work at once; also bids on two 150-horse-power engines.

SAGINAW, MICH.—The Saginaw Consolidated Street Railway Company has been incorporated with \$150,000 capital, by John M. Nicol, Frank E. Snow, William A. Jackson.

DETROIT.—General Manager Hawks, of the reorganized Citizens' Street Railway Company, says his company is considering the question of equipping the Grand River avenue line with electricity this fall.

DETROIT, MICH.—Major Edwards has been elected president of the Suburban Street Railway Company; A. Z. Johnson, vice-president; J. R. Stirling, secretary; directors, J. D. Hawks, G. H. Russell, D. M. Ferry, R. M. Wilson, and the officers.

DETROIT, MICH.—Attorney General Ellis has denied the application for quo warranto proceedings, and has declined to allow the state to be made a party to any litigation on the part of the city of Detroit against the Citizens' Street Railway Company. The only redress the city has is by mandamus to compel the attorney general to file the information in the quo warranto proceedings.

SAGINAW, MICH.—Walter S. Eddy, Warren Y. Soper and Thomas Ahearn have asked the city council for a franchise, permitting the Saginaw & Bay City Street Railway Company to build an electric street railway between the two cities. The new company is not identified with the Union Street Railway Company, which has been making preparations to build between the two cities. General Manager W. J. Hart, of the latter company, declares he will go ahead and build, regardless of the new company.

## Missouri.

KANSAS CITY, MO.—The Kansas City Traction Company has been granted franchises for its proposed extensions.

ST. LOUIS, MO.—Plans are completed for changing the Fourth Street & Arsenal Railway Company to an electric line and extending it.

HANNIBAL, MO.—The Hannibal Street Railway Company has been granted the right to extend its lines to Quincy, Ill., the road to be completed by June 1, 1895.

MARSHALL, MO.—California capitalists have been over the ground and are likely to soon begin an electric coal line from Miami to Sedalia via Marshall and Blue Lick.

SPRINGFIELD, MO.—Dr. E. C. Davis, representing Chicago capitalists, is directing the survey for an electric line, forty-five miles long, from Eureka Springs to Green Forest.

ST. LOUIS, MO.—It is said the Broadway cable line will be extended two miles from Baden to Prospect Hill, and that the Bellefontaine line is also seeking a franchise to reach Prospect Hill.

KANSAS CITY, MO.—General Manager R. J. McCarty, of the Metropolitan Street Railway Company, has prepared plans and estimates of cost for the proposed change from mule to electric power on the Broadway line.

ST. LOUIS, MO.—The purchase of large tracts of suburban property by Ex-Governor Francis, J. T. Donovan, John V. Hogan and John Scullin, is taken as an indication that there will be some new electric lines, or an extension of existing lines.

KANSAS CITY, MO.—A construction company has been organized to build a connecting line between the Kansas City Cable and the West Side Railway, of Kansas City, Kan. B. S. Coler, of the latter road, is at the head. It is called the Kansas City Traction Company, and has a capital of \$1,000,000. The directors are B. S. Coler, Brooklyn, N. Y.; W. J. Smith, and W. H. Lucas, of Kansas City, Mo.; and C. W. Trickett and F. D. Hutchings of Kansas City, Kan. The officers are B. S. Coler, president; W. H. Lucas, secretary, and F. D. Hutchings, treasurer.

## Montana.

HELENA, MONT.—The property of the Helena Rapid Transit Company has been formally transferred to the Helena Power & Light Company. The latter company is the consolidation of the Helena Electric and Rapid Transit companies.

## New Hampshire.

MANCHESTER, N. H.—J. H. Beckford, Salem, Mass., with Gen. Bartlett, of the board of directors of the proposed electric line, have said that all the contracts will be made before January 1.

## New Jersey.

CAMDEN, N. J.—The West Jersey Traction Company has secured the passage of all its ordinances.

PATERSON, N. J.—Surveyors are staking out a new electric railroad between this city and New Brunswick.

HOBOKEN, N. J.—The Jersey City, Hoboken & Rutherford Electric Railway Company has asked for a franchise.

BURLINGTON, N. J.—The West Jersey Trolley Company is getting right of way signatures here for a line to connect Camden and Florence.

SOUTH ORANGE, N. J.—Franchise has been granted to the Maplewood & South Orange Railway Company. A franchise has also been asked for by the Newark & South Orange Railway Company.

NEWARK, N. J.—The New Jersey Consolidated Traction Company has secured from the Essex County Board of Freeholders, franchises to build electric lines to Elizabeth, Orange, Bloomfield, Montclair and Caldwell.

CLARKSBORO, N. J.—A company has been formed to build an 18-mile electric railway from Clarksboro to Swedesboro, and from Mullica Hill to the Delaware river. John S. Somers of Clarkshoro, is president, and James J. Davidson, secretary.

NEWARK, N. J.—The North Jersey Street Railway Company, the Central Jersey Traction Company and the New York & Philadelphia Traction Company have filed applications for franchises between Irvington and Hilton, in South Orange township.

## New York.

SYRACUSE, N. Y.—The Syracuse Street Railway Company has asked for ordinances.

GOSHEN, N. Y.—The Middletown-Goshen Traction Company will be permitted to build

PLATTSBURG, N. Y.—The town trustees have been petitioned for an electric road franchise.

PEEKSKILL, N. Y.—Willgot Klingberg will be constructing engineer of the new electric line.

NEW YORK CITY.—The Union Railroad Company will extend its lines in Westchester county.

BLOOMSBURG, N. Y.—The town authorities have granted a franchise for an electric street railway.

MATAMORAS, N. Y.—Franchise has been granted the Delaware Valley Electric Railroad Company.

PORT JERVIS, N. Y.—The council has granted a franchise to the Port Jervis & Suburban Electric Railway.

COHOES, N. Y.—The Cohoes City Electric Railroad Company will accept the franchise recently granted.

PORT BYRON, N. Y.—Eastern capitalists are reported to be reviving the project for an electric line to Auburn.

SYRACUSE, N. Y.—The Syracuse & East Side Railroad Company has bought a site for a power house and will build.

SYRACUSE, N. Y.—The Syracuse & East Side Street Railway Company will extend its lines and use electric power.

FLUSHING, L. I.—Franchises have been given the Brooklyn City Railroad Company and the Newtown Railway Company.

BATAVIA, N. Y.—James H. Ahern, New York, has been trying to induce local capitalists to build an electric line to Le Roy.

BROOKLYN, N. Y.—The Nassau Electric Railroad Company is taking bids for a tunnel under Ocean Parkway at Church avenue.

WATERTOWN, N. Y.—The Watertown Street Railway proposes to extend from Brownville to Dexter, a distance of three miles.

LOCKPORT, N. Y.—The city council will forfeit the franchise recently granted the Lockport City & Olcott Electric Railroad Company.

NIAGARA FALLS, N. Y.—John J. McIntire is working for 20 miles of electric road around Grand Island, touching all the summer resorts.

NEW YORK CITY.—It is believed that Howard Carroll and others will build an electric line on Staten Island, to run in opposition to the steam road.

LAKESIDE, N. Y.—The Empire Construction Company has taken up the work on the abandoned Beecher single rail electric railway to Batavia.

ITHACA, N. Y.—Property owners on South Hill are talking of building a road and turning it over for a term of years to the Ithaca Street Railway.

MILTON, N. Y.—Frederick R. Barnes, representing the Boston Electrical Construction & Supply Company, has been given a franchise for an electric road.

SYRACUSE, N. Y.—The Syracuse Street Railroad Company has filed with the secretary of state a certificate of proposed extensions on ten different routes.

SYRACUSE, N. Y.—The highway committee of the city council has reported favorably on all the routes of the various street railway companies seeking franchises.

OGDENSBURG, N. Y.—The Ogdensburg Street Railway Company will relay its tracks with 56-pound rails, and will equip its line with electricity and buy new cars.

NEW YORK CITY.—The Metropolitan Street Railway Company will build the "largest car house in the world," at Seventh avenue, Fiftieth and Fifty-first streets, to cost \$1,000,000.

SYRACUSE, N. Y.—The Twelfth Ward Street Railroad Company, recently organized by Maurice A. Graves, Frank M. Bonta, Dwight H. Murray, and others, has applied for an electric railway franchise.

COWLESVILLE, N. Y.—A. H. Haskins, Charles Hart, W. T. Martin, T. Austin, Grove Barnum, Cowlesville; Loren Kittsley, Folsomdale; V. D. Osgood, Borough, are working on a proposed trolley line to Marilla.

BROOKLYN, N. Y.—The Brooklyn & Brighton Beach Railroad Company is contemplating substituting electricity for steam on its line to Coney Island.

BUFFALO, N. Y.—Capt. John M. Brinker, Buffalo, president; H. Sellers McKee, Pittsburg, vice-president; R. W. Jones, Buffalo, secretary and treasurer, are officers of a proposed electric line to Lewiston, which will be built in the spring. The fare from the Falls to Lewiston will be 50 cents.

PEEKSKILL, N. Y.—Petitions for franchises have been presented to the village board by the Peekskill, State Camp & Mohegan Railroad Company, and the Peekskill & Cortlandt Electric Railroad Company, which were recently organized. Each company has presented a certified check for \$10,000.

NEWBURG, N. Y.—The Orange Lake & Walden Electric Railroad, to be a continuation of the Newburg & Orange Lake Railway, has been incorporated. The incorporators were Benjamin Norton, Brooklyn; H. C. Norton, H. R. Newkirk, formerly of Brooklyn; B. B. Odell, Jr., Colonel William D. Dickey, Captain Joseph M. Dickey and Major W. H. Weston, Newburg.

BINGHAMTON, N. Y.—The Binghamton, Lestershire & Union Railway Company has been incorporated to construct a road six miles in length, from Lestershire to Union. Capital stock, \$100,000. Directors: Jerome B. Landfield, John Evans, John P. E. Clark, George Whitney, John B. Rogers, Frederick E. Ross, Charles J. Krapp and Theodore S. Rogers, of Binghamton, and Arthur S. Beves, of New York.

BROOKLYN, N. Y.—The Brooklyn, Newton & Bowery Bay Railroad Company has been incorporated, with \$100,000 capital, to build six and one-half miles of road. The directors are S. Fisk Washington, Alexander Hance and Alexander D. Hance, Winfield; Abbott C. Combes, Clarence E. Mundy and Peter V. P. Mundy, Newtown; Frank M. Meinikhelm and Bernard G. Meinikhelm, Maspeth; Adam Wiener, New York City.

OGDENSBURG, N. Y.—The Ogdensburg Street Railway Company will reconstruct its lines, changing from horse to electric power. Extensions will be made. The cost is estimated at \$125,000.

PEEKSKILL, N. Y.—Incorporated: The Peekskill, State Camp & Mohegan Railroad Company, with a capital of \$175,000, to operate a street railroad from Peekskill to Lake Mohegan, a distance of four miles, with branch roads in Peekskill and the towns of Courtlandt and Yorktown. The principal directors are Frederick C. Beach, Edward B. Gallagher and Charles E. Hammond, of New York City.

PEEKSKILL, N. Y.—The Peekskill & Cortlandt Electric Railway has been incorporated here, with a capital of \$150,000. The road is to be four miles long, running through Peekskill, Cortlandt and Yorktown, in Westchester county. The directors are: Edgar Peckham, New York; Benjamin Norton, H. C. Soop, W. H. Wilkinson, W. Klingberg, J. H. Burton, all of Kingston; E. De M. Lyon, W. D. Southard and E. F. Hill, of Peekskill.

### North Carolina.

RALEIGH, N. C.—The new car wheel works have started. Capital stock, \$100,000.

### Ohio.

CLEVELAND, O.—N. F. Wood is securing right of way for an electric line to Bedford.

FREMONT, O.—The council has granted extension franchises to the Fremont Street Railway.

ELYRIA, O.—The council has passed the Cleveland & Berea Electric Railway Company ordinance.

CINCINNATI, O.—The Mt. Auburn cable road has been ordered sold by the receiver within thirty days.

CLEVELAND, O.—The Cleveland & Berea Street Railway Company is back of a plan for a road to Elyria.

TOLEDO, O.—The Toledo Electric Street Railway Company will change from a single to double track system.

FREMONT, O.—The Fremont Street Railway Company will accept the recently granted franchise and extend its lines.

CLEVELAND, O.—The Cleveland Electric Railway Company contemplates an extension of its lines to Brooklyn, O.

MARION, O.—H. J. Hill and H. S. Jones, of Marion, will build an electric railway in Marion, Monon and Knox counties.

AKRON, O.—The Akron, Bedford & Cleveland Railroad Company has been granted a franchise through Summit county.

CINCINNATI, O.—The Cincinnati Street Railway Company has secured a franchise through the village of Winton Place.

BEREA, O.—L. M. Coe, of this place, has been granted a franchise to build an electric road. The Cleveland & Berea road is behind him.

CLEVELAND, O.—The Cuyahoga Suburban Railway Company has secured right of way to Chagrin Falls by way of Randall, and work will soon begin.

GALION, O.—Toledo parties asked for a franchise for an electric line, which it is proposed to build from Bucyrus. They also want an old franchise rescinded.

MT. VERNON, O.—Frederick T. Botzum, superintendent of the Cleveland & Berea road, is promoting a road from here to Walhonding, and has applied for franchises.

CLEVELAND, O.—R. S. Hubbard, treasurer of Cuyahoga county; W. B. Blake and T. S. Maxwell, Cleveland, are expecting to build an electric line to Chagrin Falls.

**BOWLING GREEN, O.**—E. H. McKnight is promoting an electric road from here to Perrysburg and Portage. Mr. McKnight is manager of the electric light plant here.

**SPRINGFIELD, O.**—Stockholders of the Springfield Street Railway Company will meet in Philadelphia next month, to vote for extensions of line and enlarging power house.

**CLEVELAND, O.**—L. A. Winch, C. N. Mix and H. P. Rose are promoting an independent electric line from Nottingham to Glenville, connecting with the Little Consolidated.

**ELYRIA, O.**—A. H. Pomeroy, president of the Berea National Bank, and Frank Carpenter, have secured the consent of the property owners to build an electric road in Lorain county.

**NORWALK, O.**—There is a project to build an electric road from Sandusky through Norwalk, Ashland and other places to Loudonville, to connect with the Mahoning Railroad, making a new outlet from the coal mines.

**TIFFIN, O.**—George B. Kerper, of Cincinnati; M. McCarthy, of New York, and M. Frost, of Fostoria, have applied for a franchise for an electric railway, connecting Tiffin, Scyamore, Melmore and Upper Sandusky.

**IRONTON, O.**—The Ironton Street Railroad, Electric Light & Power Company has been incorporated with \$100,000 capital stock, by Joseph Fisher, Lev. Ebert, H. A. Marting, R. Mather, T. J. Mulligan, A. R. Johnson, D. C. Davies, A. Winters and Mat. Anderson.

**CLEVELAND, O.**—C. C. Thompson and John Mitchell, active spirits in the Cuyahoga Suburban Railway Company, have obtained right of way to Randall, and will begin work within thirty days from the terminus of the Broadway electric line.

**COLUMBUS, O.**—The Worthington, Clintonville & Columbus Street Railway Company has had its charter amended, changing its southern terminus from Clintonville to Columbus.

**HARTWELL, O.**—Mayor Charles C. Richardson, Glendale, and secretary of the Haldeman Paper Company, Lockland, has asked the city council for an electric road franchise. It is the intention to build a line connecting Lockland, Wyoming and Hartwell.

**MT. VERNON, O.**—A franchise has been granted to the Central Ohio Electric Railway Company for electric lines connecting Mt. Vernon, Mt. Gilead and Marion. F. W. Jones is at the head of the enterprise.

**FINDLAY, O.**—An electric railway will be built between Findlay and Bowling Green via Stuartsville, Van Buren, Welker, Cygnet, with a loop at Welker to North Baltimore. George B. Kerper is the moving spirit.

**COLUMBUS, O.**—Work is progressing on the electric line between Worthington, Westerville and Flint. A traffic agreement has been made with the Delaware City Street Railway Company for a line that will be built next spring from Flint to Delaware.

**CLEVELAND, O.**—Articles of incorporation have been filed for the Akron, Bedford & Cleveland Electric Railroad Company, with a capital stock of \$300,000. The incorporators are J. F. Seiberling, F. A. Seiberling, Will Christy, James Christy, Jr., and C. H. Howland. Representatives of the Akron Street Railroad Company, the originators of the scheme, have appeared before the court commissioners to secure a franchise through Summit county.

## Oregon.

**PORTLAND, ORE.**—Sidney Dell reports that citizens of North Tualatin and the Upper Nehalem valley are organized to grant land subsidies for an electric line, taking in the valleys of the Pebble, Beaver, Upper Nehalem and Rock Creek, in which are coal fields.

## Pennsylvania.

**LATROBE, PA.**—An electric railway will be built to Pittsburg.

**SCRANTON, PA.**—The street car line will be extended from Hyde Park to Providence.

**BANGOR, PA.**—The Pen-Argyl, Bangor & Water Gap road has been sold by sheriff.

**MCKEESPORT, PA.**—A route is being selected for an electric railway from McKeesport to Elizabeth.

**MCKEESPORT, PA.**—The McKeesport & Wilmerding Electric Railway Company ordinance was passed.

**PITTSBURG, PA.**—The Traction Company's surveyors are at work on the line to Mill Creek and Miner's Mills.

**CARLISLE, PA.**—The Cumberland Valley Traction Company has adopted plans for a branch to Boiling Springs.

**TARENTUM, PA.**—The Tarentum Traction Passenger Railway Company will build four miles of road in the spring.

**HAMBURG, PA.**—Permission to pass through the town was given the Pottsville & Reading Electric Railway Company.

**HOMESTEAD, PA.**—A branch will be built to Whittaker by the Homestead & Highland Avenue Street Railway Company.

**HOMESTEAD, PA.**—Franchise has been granted the Homestead Traction Company. It will straddle the lines of the other roads.

**SHAMOKIN, PA.**—The Shamokin & Mt. Carmel Street Railway Company will begin work on its Locust Gap branch in the spring.

**CHESTER, PA.**—The Chester, Media, Middletown & Aston Traction Company will use the tracks of the Chester Traction Company.

**MAHANOEY CITY, PA.**—The Lake Side Railway Company is surveying for an extension of eight miles, and other extensions are contemplated.

**AVOCA, PA.**—Legal disability preventing the building of the Pittston, Jenkins & Avoca Street Railway Company in Avoca has been removed.

**DOYLESTOWN, PA.**—The Buck's County Railway Company has filed its bond, which has been approved by the city council. Work will be begun at once.

**HATBORO, PA.**—Senator Markley has been chosen president of the Willow Grove & Hatboro Electric Railway Company, which will build fourteen miles.

**BRAOFOORD, PA.**—A 10 per cent assessment has been levied on subscribers to stock in the Bradford Electric Street Railway Company which was organized in June.

**NEW CASTLE, PA.**—J. C. Whitla and others are figuring on buying the New Castle and Brinton Park street car lines. If the deal goes through extensions will be built.

**ALLENTOWN, PA.**—The Allentown & Lehigh Valley Traction Company stockholders will meet December 29 to vote to increase the capital stock from \$1,500,000 to \$4,000,000.

**MCKEESPORT, PA.**—Eight miles of electric road are to be constructed from McKeesport via Glenwood and Dravasburg to Pittsburg. The steam railroad route is sixteen miles.

## PERSONAL.

RUSSELL B. HARRISON, president of the Terre Haute system, made the REVIEW a pleasant visit.

A. H. DOLLARD has resigned his position as president of the Lewis & Fowler Manufacturing Company, of Brooklyn, N. Y.

B. J. JONES, of Sioux City, has been appointed superintendent of the South Chicago City Railway and has begun his duties.

A. W. GILBERT, of St. Louis, a successful promoter of water works, electric light and railway enterprises, called on the REVIEW.

COL. W. H. SINCLAIR, president of the Galveston Street Railway Company, went home from the Atlanta Convention by way of Chicago.

F. H. KILLINGER, superintendent of the Canton-Mason Electric Railway Company, gave a reception recently at Canton, O., to his railway friends.

W. D. RAY, formerly an electrical engineer of Chicago, has gone to take charge of the Everett Railway & Electric Company as superintendent.

WALTER SMITH has been promoted to be mechanical engineer and assistant to Superintendent Lynn, of the Milwaukee Street Railway Company.

E. K. STONE, JR., secretary and superintendent of the Quincy Horse Railway and Carrying Company, at Quincy, Ill., made the REVIEW a call lately.

A. B. CLARK, treasurer of the Baltimore, Md., City Passenger Railway Company, has been granted a leave of absence. Henry P. Smith is treasurer pro tem.

J. A. KERN, for several years auditor of the Des Moines, Ia., City Railway Company, has made an extended tour of the west, accompanied by his wife.

A. DERR has resigned the superintendency of the Rochester, N. Y., Electric Railway Company, to accept a similar position with the Rochester Railway Company.

L. N. DOWNS, of the new Citizens' Street Railway, of Battle Creek, Mich., made the REVIEW office a call recently. He is pushing the construction of the system rapidly.

A. K. STONE, formerly superintendent of the Omaha & Council Bluffs electric line, has been made a division superintendent of the Great Northern Railroad, with headquarters at Glasgow, Minn.

W. W. HATCH, superintendent of the new Elkhart, Ind., system, was a recent caller, and reports good pro-

gress making with construction work. As soon as the lines in the city are completed, work will be pushed on the interurban which promises to be one of the largest in the world.

PRESIDENT WILLIAM M. HAYES, of the West Chester, Pa., Street Railway Company, recently gave a wedding reception to his son Carroll and his bride, to which all employes of the company were invited.

HARRY ULLERY, superintendent of the electric street railway at Hartford City, Ind., was married recently to Miss Fanny A. Fox. The happy couple spent their honeymoon in a tour of Ohio on bicycles.

CHARLES R. HOLMES, superintendent of the Anaconda, Montana, street railway, light and water companies, and one of the youngest men in the country holding such position, was a REVIEW caller on his recent trip east.

E. W. GOSS has resigned his position as superintendent of the Amesbury, Mass., Electric Light, Heat & Power Company, and is now superintending the reconstruction and equipment with electricity of the Middletown, Conn., Horse Railroad.

W. S. DIMMOCK, general superintendent of the Omaha & Council Bluffs Railway & Bridge Company, Council Bluffs, Ia., called on the REVIEW on his way home from the convention. With Mrs. Dimmock he inspected the systems in Cincinnati, Louisville and Indianapolis.

FRANK STRANGE and Morton Dawson, two large land owners, recently ran a trip as conductors and motormen on the Broad Ripple Rapid Transit Company, Indianapolis, Ind. They are both stockholders of the company, and it is said Mr. Dawson will be general manager.

CHARLES HATHAWAY, accompanied by his son, A. L. Hathaway, were REVIEW callers when en route home from a successful hunting trip in northern Dakota. They went back 50 miles from the railroad and slept in tents during weather in which ice formed every night.

STANLEY GREEN, western representative of the Fuel Economizer Company, 574 Rookery, who has been confined to his bed for several months with muscular rheumatism, has recovered sufficiently to attend to business. His customers are very much pleased that he is with them again.

JOHN J. STANLEY, superintendent, of the Cleveland Electric Railway was arrested on three charges of violating an ordinance, which provided for an extra conductor, or motorman for trailers. When the case came up a nolle pros was entered by the director of law of the city, who said the city had no right to pass such an ordinance. It is only when attempts are made to enforce similar legislative acts adopted for political reasons, that the foolishness of the politicians is made apparent.



W. A. ARMSTRONG, superintendent of the Pennsylvania Traction Company, of Lancaster, Pa., was recently presented with an elegant watchchain and charm by the employes of the company. The thirty-first anniversary of Mr. Armstrong's birth was made the occasion of the presentation.

A. E. BAKER, assistant secretary of the Baltimore Car Wheel Company, sailed from London for Philadelphia, on October 3. Mr. Baker returns from a three months' combined business and pleasure trip, and has visited all the principal cities both on the Continent and in England, where he found rapid strides were being made in the building of electric railways, but nowhere found as rapid service as in America, which may possibly be accounted for by the fact of their being practically in their infancy.

W. F. RUDOLPH, of the Central Avenue Railway Company, Oakland, Cal., banqueted a number of Oakland and San Francisco street railway men, October 16. His guests were George Y. Loring, Oakland Railroad Company; Frank Leland, Oakland, San Leandro & Haywards Electric Railway Company; A. K. Grim, Oakland Consolidated Street Railway Company; J. E. Morris, Highland Park & Fruit Vale Railway Company; S. B. Lenegan, Central Avenue Railway Company; A. G. Briggs, Geary street road.

#### PROPOSED CHICAGO LINES.

It is given out on good authority that an electric line will be built from the corner of Michigan avenue and River street, Chicago, north across the river on Rush street bridge to Kinzie street, west on Kinzie street to the Chicago, Evanston & Lake Superior Railroad, a suburban steam road owned and operated by the Chicago, Milwaukee & St. Paul Railroad, and running to Evanston. When connection is made with the road the equipment will be changed to electricity. The steam road is 13.69 miles long. E. S. Dreyer and W. M. Hoyt are said to be interested. Mr. Dreyer, however, says there is nothing in the story, and President Miller, of the Chicago, Milwaukee & St. Paul Railroad, says the same. The information comes from such a source that though the plan may not have developed sufficiently for a proposition to have been made to the railroad company, it is likely to be done. The possession of this line of steam road would be of advantage to the proposed Chicago-Milwaukee interurban.

Notice has been given that on November 17 the North Chicago Street Railroad Company and the West Chicago Street Railroad Company will ask for ordinances for several new lines.

#### METROPOLITAN ELECTRIC COMPANY.

The Metropolitan Electric Company, 186 and 188 Fifth Avenue, Chicago, has recently added a street rail-



INSULATED ADJUSTABLE CROSS OVER.

way department. The company has been in existence for a long time, but has not entered the street railway field until lately. A full line of materials is carried in

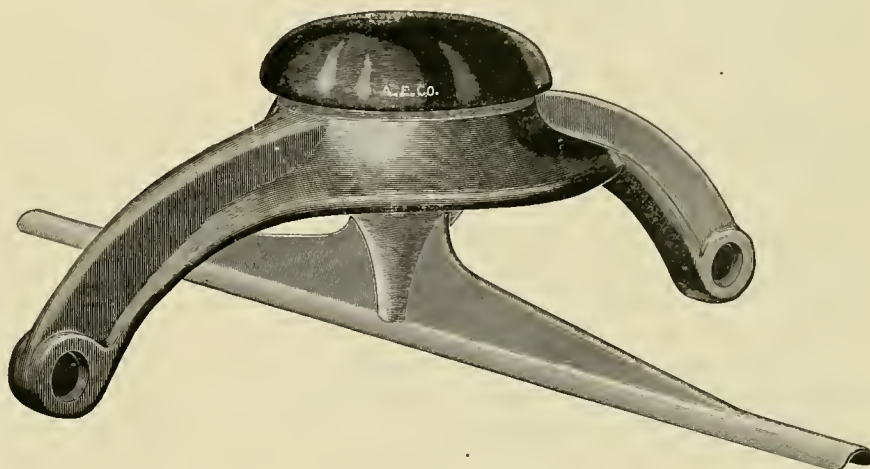

DOUBLE PULL OVER.

stock. William H. McKinlock, is president, and Walter C. McKinlock, is secretary of the company.

Among the specialties handled by the company are a double pull over and an insulated adjustable cross over. The pull over is made with light or heavy 15-inch ear. It is made for No. O. 2, B. & S., and No. 4, B. W. G., wire. The company has just issued a handsome special street railway catalog of 204 pages. It is full of illustrations and descriptive matter concerning almost every variety of electric devices. There are many valuable tables, which are convenient for ready reference. A cipher code is also appended, and each item in the catalog has a trade name, so that telegraphic orders can be sent at slight expense. The code is quite a feature of the book, and is very complete. There is also a large index, which will enable purchasing agents to find quickly whatever they may need.

A WIRE cable 21,800 feet long and weighing forty-five tons was recently furnished the Broadway cable road in New York City, by the John A. Roebling's Sons Company of Trenton, N. J.

#### Playing Cards.

You can obtain a pack of best quality playing cards by sending fifteen cents in postage to P. S. Eustis, Gen'l Pass. Agent, C. B. & Q. R. R., Chicago, Ill.



THE Consolidated Traction Company, of Newark, has adopted the Darrach fender.

THE New Castle Car Company is at work on a combination baggage and passenger car for the Goshen-Elkhart, Ind., interurban.

THE Scarritt Car Seat Company, St. Louis, has orders on hand for more than 3,000 of its celebrated reversible car seats for street railroads.

H. A. HOAGLAND, superintendent of the Marinette Street Railway, has accepted a position at the factory of the Mather Electric Company.

WAREHAM & HUGHES, Beaver Falls, Pa., have the contract for eight miles of electric road between Benwood and Moundsville, W. Va., for \$300,000.

THE New England office of Westinghouse, Church, Kerr & Co., has been moved from 620 Atlantic avenue to the Exchange building, 53 State street, Boston.

THE foundry of the Maryland Steel Company, Baltimore, is busy on an order for about 3,000 cable railway yokes, for the Columbian Traction Company, of Washington, D. C.

TAYLOR, DEE & MACK, dealers in electrical supplies at Chicago, have dissolved partnership, as a result of business complications, and placed their business in the hands of Franklin S. Terry, as assignee, who will close out the stock.

THE Scarritt Car Seat Company, St. Louis, sold the Big Four road 720 of its popular high back car seats, which will be placed in the new vestibule limited trains now being built.

THE Penney-Meyers Construction Company has a contract to build seven miles of electric line in St. Louis. The line will eventually run to Kirkwood, fourteen miles from the court house.

THE Card Electric Company, of Mansfield, O., is making a specialty of multipolar motors, iron-clad, for bridges, turntables, and all places where the motors must be exposed to weather and dirt.

CARDWELL BROS., New Haven, Conn., have the contract for constructing the Danbury & Bethel electric road, which is to be eleven miles long. The road will be parallel with the Consolidated road.

THE Berlin Iron Bridge Company, East Berlin, Conn., has secured the contract to build an iron car house with capacity for 25 cars, for the New Haven & Centerville Street Railway. The Laclede Car Company, St. Louis, will build the cars.

THE Elwell-Parker Electric Company of America is sending out from its Cleveland office a large and fully illustrated catalogue of its apparatus, which corresponds with that of its parent, the Electric Construction Company, Limited, of England.

DANIEL HIGGINS, 1719 West Lombard street, Baltimore, has furnished 1,400 badges for the Market Street Railway Company, San Francisco. He has also made the badges used by all the street railway companies in Baltimore and a number of other cities.

THE Michigan overhead material, manufactured by the Michigan Electric Company, Detroit, Michigan, and exhibited at the Atlanta convention, is meeting with great favor among street railway and construction men. The company reports encouraging sales, and an improvement in business.

THE Mather Electric Company has taken a third order for a 180 kilowatt multipolar railway generator from the Hartford & West Hartford Street Railway Company. It has sold a 100-horse-power multipolar to the Bloomington City Railway Company, Bloomington, Ill.; also a 100 kilowatt for Scranton, Pa.

THE White Manufacturing Company, 556 West Thirty-fourth street, New York City, has bought the patents and patents pending on the steel snow plow, as used by the West End Street Railway Company, of Boston, and the Brooklyn Heights Railway, Brooklyn. This plow has done excellent work on these lines.

THE Pittsburg Bridge Company, Pittsburg, Pa., has received a contract for 800 feet of steel trestle work on the line of the Akron & Cuyahoga Falls Rapid Transit Company. The Pittsburg Bridge Company is noted for the high grade of work turned out by its plant, and this work will be found to be up to the highest standard.

FRANK DE RONDE, general and genial sales agent for the Standard Paint Company, of New York, was in the city on business. He also introduces to the trade J. C. Shainwald, who will represent the company in Chicago at 871 Rookery. Mr. Shainwald is a most affable gentleman, and will be eminently successful in this new connection.

THE Consolidated Car Heating Company, of Albany, N. Y., has recently received orders to equip with its electric heaters and temperature regulating switches 100 cars of the Nassau Railway, Brooklyn; the Allentown & Lehigh Valley Traction Company and the Yonkers, N. Y., Street Railway Company, all of which are operated by the Johnson syndicate.

THE Southwark Foundry & Machine Company, of Philadelphia, is furnishing two 500-horse-power compound Porter-Allen engines to the People's Electric Light & Motor Company, of Chicago. The excellent record of the Porter-Allen simple and compound engines formerly installed has led to this second order. The company also furnishes the boilers.

THE Berlin Iron Bridge Company has erected for the Mather Electric Company, a new building 300 feet by 50 feet, equipped with the latest improved machinery and a 40-ton traveling crane, especially for the building of large direct connected generators for railway work. The unfinished castings are brought in at one end of the shop and go out at the other end as finished machines.

THE Wallace Electric Company is general sales agent for the manufacturers of the Brilliak railway incandescent lamp. It is made with an anchored filament, to withstand the severe conditions which lamps are sometimes subjected to in railway work. The railway specialties manufactured by the Wallace Company are all well illustrated in its railway catalogue, which is complete throughout, and which should be in the hands of every superintendent.

J. H. ROSE, patentee of the Lima register, has formed a combination with D. L. Bates & Bro., Dayton, O., to manufacture his new and improved register. Mr. Rose has had years of experience as a street railroad man, and has patented a number of street railway appliances. He thinks he has in his improved register, known as the Rose, one that will command the attention of street railway managers. It is handsomely finished in nickel, and in polished and oxidized bronze.

THE Mather Electric Company, of Manchester, Conn., reports, as a sign of the revival in the electrical business, the closing in three consecutive days of contracts for more than 1,500 horse-power of its standard apparatus, consisting of direct connected and belted generators, and its Manchester type slow speed motors. This, with the other work the Mather Company now has on hand, will compel it to at once increase its working force, although part of the works is now being operated at night.

THE Griffin Wheel Company, of Chicago, reports a most satisfactory month's business in October. Orders from steam railroads numbered more than any previous month this year; some important time contracts were closed and new customers secured among the larger electric roads. Reports of excellent service resulting from the use of its special chilled iron wheel under electric cars are constantly coming in, and state that they find the managers of these roads are fast learning that it is often false economy to buy the lowest priced wheels and are now looking more to quality than to price.

THE Lane & Bodley Company, Cincinnati, O., the well known engine builders, is receiving bids for limestone foundations, brick, carpenter and mill work, roofing and structural steel work, for a new addition to the machine shop, 40 feet by 147 feet, six stories in height, and also for building materials separately therefrom, and has specifications prepared for electric power generating and distributing plant, including motors, wiring, arc and incandescent lamps and several direct motor driven machine tools. Specifications may be had on application.

THE Philadelphia Electrical Equipment Company is a new concern, the organization of which it gives us great pleasure to announce, as it has as general manager the well-known street railway man, C. P. Young, formerly superintendent of the Chattanooga Electric Railway and recently in construction work around Philadelphia. The new company will do all kinds of electric railway contracting, and besides this has an elegantly equipped shop for doing all kinds of repair work at 816 to 822 Cherry street. Those who are acquainted with Mr. Young's thoroughness, as well as his large practical experience in the operation of electrical apparatus, will know that whatever work is done will be as near perfect as it is possible to make it.

THE Siemens & Halske Electric Company's factory was destroyed by the great lumber fire, August 1, in Chicago. The company made a lease with the Grant Locomotive Works, August 11, and commenced moving into the new works August 15. The company on October 15 finished and shipped the first generator, built entirely at the new factory. Every available tool in the new works is now in operation, and many of the tools which were destroyed in the fire have been duplicated so that from now on the company is in the position to finish one direct-coupled generator each day. These few simple facts indicate the dauntless spirit of the company, which is to-day in a better condition for competition in the electrical field than before the fire.

THE New Process Rawhide Company, Syracuse, N. Y., is happy over a very pleasant testimonial letter from H. S. Cooper, general manager of the lines at Schenectady, N. Y., who writes as follows:

"We enclose our order for two more No. 16 Edison pinions, same as before. The pinions have done excellently well. On May 10 we equipped an open car with steel pinions; on May 28 we equipped an identical car with rawhide of your make. To-day the steel pinions are worn out, and have also worn out the axle gears in which they mesh, while the rawhide pinions are not nearly worn out, and the axle gears in which they mesh are not worn at all perceptibly. Both these cars have run steadily over identically the same route, and have carried very closely the same number of passengers, and averaged the same mileage, 100 miles per day. As you know, our road is a very hard one on gears, as it is all curves and grades, with the curves all on grades 6, 7½, 10 and 12 per cent, and some of them pretty long ones. We are well pleased with the results, the more especially as the writer was somewhat dubious at first as to the using of rawhide on single reduction machines, although his experience with them on double reduction had been very satisfactory."

CHARLES A. SHELDON has been put in charge of the compressed gas lighting department of the Consolidated Car Heating Company, Albany, N. Y., which is introducing the Pope system, interchangeable with the "Pintsch." Mr. Sheldon graduated from Yale in 1890, and was employed by the Lake Shore & Michigan Southern Railroad, rising to the position of assistant division superintendent of the Michigan division. The Consolidated Car Heating Company has secured an order from the West End Railway, Boston, to equip 149 cars with electric car heaters, after a competitive test with five companies. An addition to the factory is being built, which will double the capacity of its departments of electric heating appliances and compressed gas.

THE Scarritt Furniture Company, St. Louis, has a most attractive display of street car seats at the St. Louis Exposition. The different styles of seat are arranged within a palace street car, which is open at the side and very brilliantly lighted by the Pintsch light. The Scarritt Company street car seat has been adopted by many railways and has found favor everywhere, especially in St. Louis, where it is in use on the Lindell Railway, Compton Heights, Union Depot & Merchants' Terminal Railway, Taylor Avenue Railway, Union Depot Railroad, Baden & St. Louis Railway, Citizens' Railway, South Seventh Street Railway and the Laclede & Fourth Street Railway. Scarritt seats have been shipped to almost every part of the United States and to a dozen foreign countries. Fully 200 steam roads in America use them

H. O. NOURSE, of 941 Rookery, agent for the Scarritt Car Seat Company of St. Louis, was born in Bardstown, Ky., in 1852, and acquired his education in Kentucky public schools and at the Mechanical and Agricultural College at Lexington. In 1874 he entered railroad work with the Elizabethtown & Paducah R. R., later going with the Louisville, Cincinnati & Lexington. With this company he remained seven years, when he was appointed purchasing agent and later auditor of the Monon. In 1884 he removed to Chicago, and in 1886 went into the supply business as agent for the Dickson Manufacturing Company, of Scranton, with headquarters at Chicago. After a successful term in this line Mr. Nourse took up general supplies until August last, when he became minister plenipotentiary and envoy extraordinary for the Scarritt Car Seat Company. He reports business flourishing and street railway car seats of the Scarritt type in active demand.



H. O. NOURSE.

THE McGuire Manufacturing Company, of Chicago, has orders for November delivery which show a large improvement in street railway business throughout the

entire country. Orders were from the following parties: Consolidated Traction Company, Jersey City, 22 Columbian trucks and 117 of the Columbian A 1 suspension trucks; Norwalk Street Railway Company, Norwalk, Conn., 13 Columbian trucks; American Car Company, St. Louis, 12 adjustable traction trucks; Augusta Street Railway Company, Augusta, Ga., 10 A 1 suspension trucks; Allegheny Traction Company, Pittsburg, Pa., 10 A 1 suspension trucks (being a duplicate order); 40 A 1 suspension bicycle trucks from the Consolidated Electric Railway Company, Los Angeles, Cal., and 60 Columbian trucks for the Chicago City Railway Company. The Toledo Consolidated Street Railway Company, Toledo, ordered two combination track sweepers and snow plows; the Citizens Street Railway Company, Indianapolis, 2 combination snow plows, and the LaCrosse City Railway Company, LaCrosse, 1 combination snow plow. The company also reports orders for nearly 700 car heaters for the month of October, which is certainly a good evidence of reviving business.

#### CONVENTION MEMORIES.

Just before the convention party left Chattanooga on the Saturday of convention week, a meeting was held in the railroad depot. A committee was appointed to prepare resolutions expressing the grateful feeling of the party towards its hosts for the manner in which it was entertained. The committee met in Chicago, November 2, and prepared the following:

Before memory stores a treasure in its crystal vaults, it seeks expression in some word or sign.

Consequently the members of the American Street Railway Association and their friends desire, through the undersigned committee, to extend to the people of the City of Atlanta, Ga., a vote of sincere thanks for their hospitable treatment of the association during its convention held in their city, October 17th, 18th and 19th, 1894.

Particularly do they desire to thank the officers and employees of the Atlanta street railway lines for many favors received at their hands.

Also, would we recognize the very hospitable manner in which we were received by the Capital City Club, and thank its eloquent president for the very graceful tribute paid to the genius that has worked out the problem of rapid transit for municipalities, and the beautiful compliment rendered to the ladies in attendance. Nor can we soon forget the barbecue.

Appreciating that our indebtedness to the Southern hospitality which prompted the preparation for this long-to-be-remembered occasion, can never be liquidated, at the same time, if our expression of gratitude will in any way be acceptable, we trust that those to whom we are under so many obligation will accept this recognition.

On behalf of the Boston, New York, Philadelphia, Chicago and other parties who, on October 20th, spent such a delightful day at Chattanooga, Tenn., the committee desires to thank the officers of the Lookout Mountain Railroad, and, also the officers of the street railways of Chattanooga for courtesies extended to them in excursions to various points of interest about the "City of the Bird's Nest."

(Signed)

H. O. Nourse, Chairman,	M. J. Sullivan, Electrical World,
James W. Nagle, The Car,	T. C. Martin, Electrical Engineer
James Boyd, STREET RAILWAY	W. Forman Collins, Western
REVIEW,	Electrician,
John B. Bennett, Street Railway	
Journal.	

THE Grand Island (Neb.) Street Railway has been sold to A. W. Ockabock, Portland Ore., for \$10,000.

## PROGRESS OF CONSTRUCTION WORK IN CHICAGO.

Work on electrical construction is now being pushed rapidly by all three of Chicago's great street railway systems and there is also much activity among the suburban roads.

### THE CHICAGO CITY RAILWAY

had the advantage of the other systems in having its power station already erected and three crosstown lines in operation when its additional franchises were granted last summer. Its electrical and mechanical department was already in shape for pushing the electrical construction and many plans and drawings had been prepared when the first lines were opened last year. About a month after work began a 5-mile route on Thirty-ninth and Halsted streets was opened for traffic. In the power station the foundations are ready for the three new 1,400-horse-power units to be put in. The capacity of this plant will be 7,000-horse-power. The State street cable line below Thirty-ninth street is being relaid with the beveled rail illustrated in our September issue. The Wheeler joint is being used on the new work. This it will be remembered, is a wedge joint having no bolts. The wedge is driven up with a twelve pound sledge. The rail ends are butted together closely. The results obtained with these joints will be watched with interest. The 600-horse-power Westinghouse motor for running the Fifty-second street cable plant has arrived but will not be put in place until the new work in the electric station is finished which will be well along into the winter. The plan of keeping all the trolley line sections insulated from each other is to be rigidly adhered to in the new work as it has been in the past. Each section will have its own feeder and each feeder its own circuit breaker and ammeter on the switchboard. This plan is not usually followed out on large roads because of the great amount of copper required, but reliability and the confining of interruptions to one section were more important than cost of copper in this case.

### THE NORTH CHICAGO STREET RAILROAD

has its power station at Roscoe street and the north branch of the Chicago river nearly finished. It is a one-story structure with basement. Condensing engines will of course be used. The present contract calls for four 620-horse-power direct connected Siemens & Halske generators and Fraser & Chalmers vertical engines. The engine room will have iron floors and the boiler room concrete. The ultimate capacity is to be 6,000-horse-power.

In addition to this station the same company will build a 4,000-horse-power station near Division street on the canal opposite Goose Island. There are to be four units of 1,000-horse-power, direct connected. This plant is to supply the southern part of the company's territory. It is located on the line of the C. M. & St. P. Railroad.

### THE WEST CHICAGO STREET RAILROAD

is laying the foundations for the largest railway power plant in Chicago, at the corner of Western avenue and Washington boulevard. It is central to the west side territory and is on a lot which has been owned by the company for many years. The ultimate capacity is to be 11,000-horse-power, consisting of five 2,000-horse-power, and one 1,000-horse-power units. Present contracts call for three 2,000-horse-power Siemens & Halske generators and Fraser & Chalmers engines and one 1,000-horse-power unit from the same firms. Twenty Stirling water tube boilers of 400-horse-power each will furnish steam. The stack is to be 240 feet high with an inside diameter of 16 feet. There is a not unreasonable rumor that if the Lake Street Elevated (which is also controlled by the Yerkes syndicate) is changed to electricity it will be supplied by this power station. Underground feeders will be laid for a mile south from this station. J. R. Chapman has charge of the electrical work on both the north and west sides.

### THE METROPOLITAN WEST SIDE ELEVATED

road with the electrical department under the charge of W. E. Baker is beginning to get above the city grade line with its power station at Throop street near Van Buren. It is located between the four tracks of the elevated structure. Vertical Allis cross compound condensing corliss engines and General Electric direct connected generators will be installed. Two units of 2,000-horse-power and two of 1,000-horse-power are to be put in at present. The station can be enlarged to more than double this capacity by building an extension. It is now 300 feet long by 90 feet wide. It will not be finished before spring. That part of the road east of the river or the down town terminus is not yet built. One half of the jack-knife bridge across the river is completed.

### THE CHICAGO GENERAL RAILWAY

has the walls up for its 1,600-horse-power plant and 100-car barn at Kedzie avenue and Thirty-first street. The work is described in detail elsewhere in this issue.

## THE GIRL IN BLUE TIGHTS.

Visitors to Chattanooga, Tenn., on their way home from the convention, no doubt remember the pictures of the girl in blue that ornamented the walls and bill boards. Originally she was dressed in blue tights, but the day before the visitors arrived, the chief of police compelled the theatre manager to put skirts on the figure. On Saturday the street railway people gazed on a girl with blue decollete waist, and short skirts of red and white bunting, speckled with stars. The curious inspected the garments, discovering that the bunting was tacked on. The courts have since passed on the case, and decided that the picture was not indecent, arriving at the decision after hearing expert evidence from leading citizens of Chattanooga.

## THE SWEET LIMIT SWITCH FOR CARS.

Some time ago we illustrated the switch made by the Sweet Electric & Manufacturing Company, of Grand Rapids, Michigan, for use on station switchboards. It has been recently adapted for use on electric cars. It is intended to take the place of both fuse box and canopy switch, as with it the motors can be cut out by hand as well as automatically. It is much quicker in its action

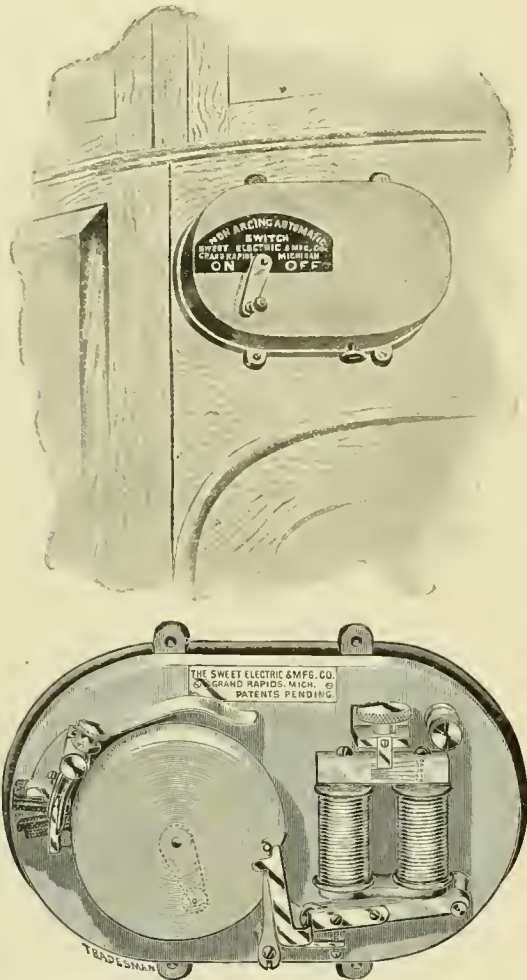

than a fuse in case of short circuits. It is only 11 inches long, 8 inches wide and 3 inches deep. The final break of the circuit is made between carbons so that there is no serious arcing. It is quick enough in action to be some protection against lightning, and is so sensitive that it quickly detects overloads on the car and makes motormen careful, whereas a fuse will stand considerable overload for several seconds without blowing. The principle of the switch is the same as for the station switch.

**WARDWELL BROTHERS,**  
**Electric · Railway · Builders,**

NEW HAVEN, CONN.

BOX 868.

Will make proposals for the Construction of all Classes of Street Railway Tracks, Power Houses, Etc.

## NEW YORK VOTES FOR RAPID TRANSIT.

New York City, by a majority of 68,790 votes, decided in favor of the city constructing a rapid transit road. Under the law, construction must begin within 30 days after the Rapid Transit Commission has received official notice of the result of the election. The road will be underground from the Battery to the northern limits of the city, and operated by electricity. The cost will be met by an issue of \$50,000,000 of bonds, bearing 3 per cent interest.

Concerning the details of construction little is known, except that a meeting of the Rapid Transit Commission was called for November 13, to consider plans. This meeting was held too late for an account in this issue of the REVIEW. The city will own the road, and it is estimated that it will cost \$30,000,000 to complete the road, in addition to the \$50,000,000. The city will lease the road to the contractor, who shall deposit \$1,000,000 in cash, and an approved bond of \$5,000,000 before beginning work. When the road is running he shall pay as rent a sum equal to the interest on the bonds, and one per cent on \$50,000,000 additional. The contractor's lease will be for 35 years, and he must provide cars, motive power and other appliances for its operation, the city having a first lien on the property. The city has a right, in case of any breach of contract, to take possession of the equipment of the road, and operate it at the expense of the contractor.

The commissioners will carefully consider all the plans that have been heretofore presented to them, and it may be some time before a definite plan is decided. At any time the plans can be changed. The tunnel will be constructed under Broadway, beneath the cable line to the Boulevard, and thence to the upper end of Manhattan Island. It is proposed to build a branch from Union square up Fourth avenue to Forty-third street, with extensions later.



**ACME**  
**Insulating Paint**

GLOSSY BLACK FINISH,  
Good Body, Dries at Once,  
Adhesive, Flexible.  
Acid and Oil Proof,  
Water and Weather Proof.

**The Paragon Insulating Co.**

1005 SOCIETY FOR SAVINGS BLDG.,  
CLEVELAND, O.

**C. E. LOSS & CO.,**  
**General Railway Contractors.**

Estimates made on all classes of Engineering Work.

**621 Pullman Bldg.**

**CHICAGO.**



WINDSOR & KENFIELD,  
PUBLISHERS AND PROPRIETORS.

269 DEARBORN ST., - - - CHICAGO.  
Published on the 15th of each month.

SUBSCRIPTION, - - - TWO DOLLARS.  
FOREIGN SUBSCRIPTION, - - - 20 SHILLINGS.

Address all Communications and Remittances to THE STREET RAILWAY REVIEW,  
269 Dearborn Street, Chicago.

H. H. WINDSOR, Editor. F. S. KENFIELD, Business Manager

**CORRESPONDENCE.**

We cordially invite correspondence on all subjects of interest to those engaged in any branch of Street Railway work, and will gratefully appreciate any marked copies of papers or news items our street railway friends may send us, pertaining either to companies or officers. Address:

THE STREET RAILWAY REVIEW  
269 Dearborn Street, Chicago

Eastern Office, Room 14, No. 126 Liberty Street, New York

This paper member Chicago Publishers' Association.

Entered at the Post Office at Chicago as Second Class Matter.

VOL. 4. DECEMBER 15, 1894. NO. 12.

THE Elektrotechnischer Anzeiger is authority for the statement that of six Luhrig gas motor cars put on the Dresden Tramway last July, four have from various causes been withdrawn. 'Twas ever thus.

AN interesting case is reported in our law digest this month, in which the supreme court of the state of Washington rules that a passenger who attempts to board a moving car, even though its speed had been reduced on signal of the passenger, does so at his own peril.

MAYOR PINGREE, of Detroit, he who has been so considerate of the rights and property of the street railway in this city, recently caused his carriage horses to be shot as a matter of economy, stating he could buy more in the spring for less money than their feed would cost for the winter. His humane ideas, which, however, are not largely shared, may also be seen in his recommendation to his board of public works to dispose in the same way of the idle horses belonging to the city.

THE New York state law very justly makes it hot for those who tamper with electric wires. Considering the loss of life and property involved this is as it should be. Those who have a knowledge of electricity can cause serious damage by interfering with power circuits. Offences of this nature are becoming more frequent as the use of electricity increases and laws on the subject

would be in order in all states, although it is usually possible to secure the punishment of the guilty parties, even if there is no special law to cover the case, of tampering with electric wires.

It has recently been shown that with a trolley road costing about \$6,000 per mile the cost to the country lying one mile on each side of an electric road would be only \$4.60 per acre. This is not a very high figure, and it seems as if in most cases the electric road would be worth more than that to the country it passes through. The figure of \$6,000 a mile is perhaps rather low and could hardly be made to cover the entire cost of a road, but on figuring on country feeders to trunk interurban lines it would be fair to count simply the cost of track and line, so that \$6,000 a mile ought to cover it.

IF the New York "rapid transit" scheme continues to move with the same alacrity which has characterized its motions thus far, there are some grounds of expectancy that the great-grandchildren of the present promoters may live to witness its completion. The Brooklyn Standard-Union says: "Rapid transit down Park Row, traveling under the foundations of the 'World,' 'Tribune,' 'Times' and Potter buildings and the postoffice, and then taking a slant down Broadway, will be a daisy of an enterprise. Fifty millions can be spent between the City hall and the Battery, and then the elevators that go down would be extra."

REPORTS have come to us from small roads in different parts of the country that they are compelled to cease operating during the winter months. A few are electric lines, while others are horse lines. The reason given in every case is that there is not enough traffic to pay expenses. A certain line will continue to operate one car as long as the driver can collect enough money to buy feed for the horses. It is a difficult but strictly local question as to what extent a company can go in operating at a prolonged loss, and would seem to raise grave doubts as to the judgment of those who first conceived the enterprise. It is to be hoped that revival of business the coming year will again place all such roads in position to maintain constant service and at a profit.

THE Philadelphia Press very sensibly comments on the evil of granting franchises good for 10, 20 or 30 years, which permit the recipient to postpone construction of the lines so granted for a long term of years. A reasonable time in which to build should always be granted, and there are also cases where companies through no fault of their own are prevented from installing for two or even three years. But such are exceptional cases and are entitled to favorable consideration and temporary extension of time. But the granting of a franchise of any kind which ties up a street for a long term of years is bad policy, and while in some ways a good thing for the grantee, eventually works evil through the change of public sentiment from friendship to hostility.

THE Pennsylvania State Association has a much needed work before it at the coming session next month of the legislature. As the law now stands and passed at the instigation of the steam roads, notably the Pennsylvania railroad, interurban electric roads are debarred from a freight service, which is almost a necessity to the existence of such lines. There is neither justice nor reason in the law, and the sooner it is repealed the better for everybody. Even the steam roads which are now alarmed at the prospective competition, will find that the electric interurbans will create a large volume of business for steam roads, and in the long run prove an advantage rather than otherwise. Improvement of country roads might be objected to on equal grounds and with quite as much sense.

WATTMETER tests taken on the individual cars of one of the largest electric railway systems of the west, show the consumption of 25 per cent less energy with series-parallel control than with the plain rheostat. It has been claimed as a further advantage of the series-parallel controller that it evens up the sudden short variations due to the starting and stopping of cars, so that no more power is required when a majority of the cars are started at once than when the majority are running at usual speed. By inquiries among railway power plants we have been unable to learn that this is strictly true although there is some difference in favor of the new method. The greatest advantage of the series-parallel method is in the power saved when running at less than maximum speed and in pulling heavy loads on grades.

NEWS seems to move slowly eastward, judging from an editorial in the *City Leader*, of London, England, which says: "The Glasgow corporation, since they are considering the question of mechanical traction for their tramway system, may be influenced by the fact that even Chicago has now come to the decision that the tramway companies there cannot be authorized to use overhead wires in connection with the electric traction, and they have therefore had to adopt the accumulator system." If anything Chicago "has come to" is any guidance to our Glasgow friends, we would state that there are now in this city 200 miles of horse car lines being changed to the overhead trolley system, just as rapidly as men and money can accomplish the transformation. As for the "accumulator system," the term has a very familiar sound, but belongs to so remote a past we had almost forgotten all about its great promises and greater failure.

A DECISION in the Exchequer court will have important bearing on street railway construction in Canada, until the higher courts, to which the case has been appealed, renders the final ruling. Under the act of 1887, passed for the purpose of promoting railroad construction, steel rails were admitted free, for railroad use. The customs department, however, held that the exception does not apply to the same weight and quality of rail when imported for street railway purposes. The Toronto

Street Railway sued to recover \$56,000 duties paid on its iron. The case went against the street railway and will now go to the supreme court, and from there to the Privy council. The ruling is obviously unfair and illogical. The duty, or an exemption of duty, should apply the same to steam and street railways. It is inconsistent to impose taxation in one case and remit it in the other upon identically the same article, and an article used to promote the same ends in both cases.

A CINCINNATI clergyman recently asked for warrants for the arrest of a gang of trackmen who were repairing the car tracks on Sunday. The company insists the work could be done at no other time. If arrests are to be made along such lines, why not be consistent and extend the good work. How about the church sexton who dusts, and fires and turns on the lights, and puts in a long day's work on Sunday? And the hired organist, who plays for money and would not do so from his own individual desire to worship; and the high-priced choir, who warble for so much a warble per Sunday; and even the parson himself, no one expects him to preach for glory alone—but enough. We certainly are not out in favor of one stroke of unnecessary work on Sunday. There is too much of it at best, and the physical and mental man cannot attain his best without that stated time for rest, but where, in such a case as the one mentioned, the mayor had issued a permit to allow the work, the arrest of these men can subserve no desirable good end.

SOME doubt was recently expressed in the columns of a street railway publication as to whether the additional power required by a dirty track is sufficient to warrant running sprinklers or sweepers. On clean streets the small amount of dirt that gets on the rails does not require much extra power, but when the rail is dirty enough to be called "bad" it is hard to figure anything but a saving by keeping the rails sprinkled or swept. An 8-mile road running 16 cars on a  $3\frac{3}{4}$  minute headway will have a daily car mileage of 2,304, running 18 hours a day. With coal at the very low figure of  $\frac{1}{2}$  cent a car mile and a clean rail the daily coal bill would be \$11.52 cents. The additional power required with a bad rail is from 10 to 50 per cent, so that the extra coal bill will be from \$2.30 to \$5.76 per day for the road under consideration. As coal usually costs more than  $\frac{1}{2}$  cent a car mile the extra expense would generally be more. If a clean rail can not be maintained for less than this by sprinkling or sweeping, there must surely be a screw loose in the management.

Two decisions have recently been delivered by United States courts, which establish two important principles of law. The first was the Detroit case, which establishes the fact that a city does not grant a street railway franchise, but simply consents to its exercise. In the Indianapolis case, Judge Woods has given an opinion that the charter granted by a legislature is in effect perpetual,



subject only to amendments of the creative body, so that if consent of city council is only for a term of years, the charter of the company will enable it to continue in possession of the rights conferred by the city until the end of time, notwithstanding a limit has been placed by the city. This is important for street railway companies to know, especially those which see the end of the life of their ordinances approaching. Every company will endorse this statement of Judge Woods: "In the nature of things a street railway once established, where needed, will be of perpetual and increasing utility, and there seems to be good reason why the franchise should cease while the utility lasts."

NOTHING better illustrates the perfection of modern electric railway work as compared with that of a few years ago than the difference between the average trial trip of to-day and that of the earlier days. The time is not long past when a trial trip was justly the cause of much apprehension on the part of the electrical engineer in charge. Trouble was to be expected at "every turn" in both a literal and a figurative sense. If the engineer was unwise enough to make the trial trip coincident with the opening ceremonies an ironical fate was sure to bring the car carrying the official party to a halt somewhere along the line. The wise engineer would operate cars in the night for a week or two before the opening ceremonies took place. It is now a very usual occurrence on well built roads to open a road for traffic within 48 hours of the time the first car is run over the line. This simply goes to show that there is less of the cut and try method than formerly, and that electric railroading has been reduced to the same well understood basis as the other commercial arts.

It is greatly to be hoped that Governor Flower will see his way clear to grant the necessary order permitting the experiment of resuscitation to be made on the body of the next victim of electrocution. There has been a very grave question of well founded doubt all along, in the minds of many of the foremost electricians, that the post mortem (?) surgeons and not the electrical current have been the real executioners. Now, let the truth be known. The condemned stands a chance of being restored to life and liberty, and certainly can make no objection, for he has everything to gain and nothing to lose, and should he be restored to consciousness and animation might well be set free as a reward. If on the other hand all known methods of restoration fail, the condemned will still furnish just as interesting a subject for articulation and the public mind will be freed from gruesome doubts. If the current is found not to have caused death, and only effected a temporary suspension of vital functions the knowledge will be invaluable in stimulating renewed and persevering work on such patients as may hereafter suffer accidental shock, and who heretofore have been given up for dead when possibly prompt and intelligent effort might have saved their lives.

THOSE who are financially interested in street railways can afford to spend some time and thought in stamping out the pernicious custom of some supply companies of "influencing" employes that are entrusted with the selection of supplies. Such influence does not always come in the way of a cash "rake off" to the man who recommends certain supplies to his trusting employers, who know nothing about the technical details of the business, but in whatever form it comes, it does not require a very deep thinker to see that the result is not the best either to the street railway or to the supply trade. Honest supply companies that make goods to sell on their merits, will be glad to see this reform, because it will put them on an equal basis with the wire pullers. The owners of roads can not afford to have goods bought on any basis except that of actual merit, nor can they afford to have in their employ, in any position, men who will recommend goods on any other basis. The supply men's influence is not always confined to low places, and for that reason it is not always a pleasant or easy task to inquire into the reasons for the awarding of contracts, but we are sure that both railway owners and supply men will agree with us that the practice is bad for all concerned, and that it will benefit both sides to have it stopped.

WHILE the dear public is humanely crying for vestibules for the motorman, it doesn't take into consideration the fact that vestibules are likely to make the running of cars in the winter more risky than if there were none. In November, a motor car of an Ohio road crashed into a freight train standing on a crossing and seven men were injured, two of them seriously. The motorman was unable to see the train on account of the steam which had collected on the windows of the vestibule. In fact, he said he could not see objects ten feet in front of the car, and it was early morning, the car being on its way to the barns. Everybody who rides, knows that windows of all kinds of vehicles become coated with steam or become frosted in cold weather. Unless the glass can be kept clear, there is constant danger of accidents. This defect in vestibules suggests that some device must be adopted to keep the windows clear. Moderate heat only aggravates the difficulty, and enough heat to prevent frosting the windows would compel the motorman to keep them open, thereby causing the very conditions that have brought about the agitation for vestibules. If the body of the motorman is protected from the wind by a partition or extension of the dash, stopping even with his shoulders, so that his view is unobstructed, he will be amply protected, and the risk to passengers will be much less than if glass is used.

A PHILADELPHIA kicker writes a daily paper there, urging the public to adopt his plan of making a pencil memorandum of all shortcomings noted on the part of conductors and drivers. While every manager is glad to be advised of the violation of well known rules, on the part of his men, when such actually exist, his long experi-

ence has taught him that in probably four cases out of five a careful investigation will reveal the fact that the report was prompted by personal resentment, or if made in good faith, was subject to mitigating circumstances of which the complainant was ignorant. The great trouble is, that passengers look upon the operation of a street car system as one of the simplest things in the world to manage, which, if satisfactory to everybody, reflects no special credit on the executive, and furthermore, every individual who pays his five cents is proudly conscious of his ability to run the road a great deal better than it is being run. These conditions combine to make the hundreds of "reports" sent in by well meaning people unreliable and unfair, and there are roads where, if the manager acted on all the complaints sent in and blindly accepted such as true, an entire new set of employes would be needed every three months. It is one of the easiest things in the world for a person to be absolutely sure and yet be radically mistaken, and reporting car and conductor numbers is no exception to the rule.

In another column will be found an unusually practical and suggestive article from the pen of a successful superintendent, that deserves editorial mention here. The name of the road, and that of the writer, for obvious reasons, cannot be stated, but the very unusual record of 5,000,000 passengers carried the past twelve months, without incurring the loss of a penny for personal accident claims, cannot but appeal to all our readers. In the same period the property damage charge was only \$89.10, and of this amount \$35 went for attorney's fees. As stated in the article, local conditions must always bear an important influence in the working out and adaptation of any successful plan, but what has produced such marked results in one instance cannot fail to be valuable elsewhere. As mentioned in the article, too many managers accept as inevitable the proposition that cars cannot be operated without incurring personal injury, and unquestionably the larger the city the greater this liability, and the more difficult to utilize, to its fullest extent, the plan described. But there are very many roads working under practically the same conditions, where the item of damages each year runs into four figures. Money saved is money earned, and when that saving is accomplished in the claim department, it may almost be said to be doubly earned. We commend the article to the careful study of managers who have been trying, with disappointing success to reduce the losses in this direction. We shall be glad to hear from others.

THE public and the complaining daily papers have no idea of the systematic and thorough effort that is being made by the large systems in eastern cities to find a good fender. Hundreds have been tried and found wanting, and yet the public is of the opinion that it is pure obstinacy that keeps companies from adopting a perfect fender at once. While on the subject of fenders it may not be amiss to quote a master mechanic of a large sys-

tem who was showing some visitors the various fenders that had been tried by him. After exhibiting device after device and telling of the results obtained by each in actual practice, he finished the exposition as follows: "This is the fender that we have adopted as our standard. It is the best thing that we have found, and in my opinion it isn't worth a d—. It extends so far in front of the car that at dusk and after dark, people who are crossing in front of the car are continually falling over it, so that it knocks down a great many people that would otherwise be untouched. Another trouble is that wagons often drive over it and wreck it—necessitating of course a new fender." From this master mechanic's remarks it will be seen that a railway company is between two fires as regards projecting fenders. If it does not adopt them there will be a certain number of fatal accidents. If it does adopt them some accidents will be prevented, but there will also be a number caused by the fender alone, and there will also be a regular repair account for smashed fenders. The fact that several large companies use the projecting fender in spite of the objections to it looks as if the latter course had been found to be the best and cheapest, although the projecting fender is by no means an unqualified success.

THE electric conduit road now building on Lenox avenue, New York, can but strengthen the belief that the trolley is here to stay and that the conduit or any other underground system will never revolutionize our electric railways. The Lenox avenue conduit which is the design of a corps of the most able electrical engineers of the country, and is evidently the cheapest form of construction that those gentlemen think has any prospect of success, is still much more expensive than the cable to build and so is suited only to the heaviest traffic, such as exists on but a few lines in this country and in places where the cable is now doing the work satisfactorily. If 500 volts could be used with success on an underground system there would be some prospect that an electric conduit system might some day take the place of the cable on certain roads where a large number of trolley lines act as feeders to the cable lines and where the operation of the entire system by electricity would simplify matters enough to make a saving on the whole road which would counteract the low operating expenses of the cable part of the system. Operating a system that is all electric ought to be cheaper than operating one that is half cable and half electric. The Chicago roads are soon to be confronted with the inconvenience of having two kinds of mechanical motive power. This is discussed somewhat at length elsewhere in this issue, in connection with a device for throwing the motors out of gear so that they can be hauled as trailers on cable trains. The use of electricity all through, instead of electricity on one part and cable on another, presents some economical advantages in the way of centralizing power stations and simplifying matters in the repair shops. However, the possibility of such a change taking place is largely dependent on the practicability of using 500 volts on the

underground part of the system. If the voltage must be lower than this on the underground part, nearly all of the advantages of having the whole system electric would disappear, because, the underground trolley would require a different set of motor cars and a different set of generators to drive them. The same cars should be able to run over both overhead and underground lines and the same set of generators supply both sections of road. As the Lenox avenue conduit is to use only 250 to 300 volts it looks as if the able engineers who designed it did not consider 500 volts a reliable pressure for conduit work, and if their decision proves correct there seems to be little hope that the conduit system will occupy the field mentioned above.

---

#### ADVERTISING IN STREET CARS.

Advertising in street cars has now become one of the best known, and, to the advertiser, popular and profitable mediums, sought by discriminating business men. There was a time when both the public and the big advertiser did not look with favor on a scheme which has been tried and found valuable in England long ago. This fact, and a lack, or imagined lack, of the proper knowledge of how the business could be profitably conducted, made easy work for the many street car advertising companies, who took advantage of this want of experience to belittle the possibilities of the business and magnify its expense. Naturally many contracts were made at prices which brought the street car companies a very small share of the profits of the business. Many roads now see, too late, their mistake in contracting at so low figures, or even where what seemed a fair price was obtained, that they did not insist on more, which they would have secured. That the scheme has been a fat one for the promoters is evidenced by the big salaries paid those in charge; the frequent and prolonged trips to Europe and the fat dividends paid even after all these expenses. That the owners of the cars which alone make possible such sure and profitable a return should ever see so little of the earnings is a matter of regret.

A glance at the line of ads taken by these advertising companies shows the great majority to be patent medicines, baking powders, and similar household articles, while the local advertiser, the home merchant, is rarely seen outside the big cities. That the local advertising which can be changed as often as desired, commands a higher price is well known; but a company several hundred miles away cannot handle this local business as cheaply as the railroad company itself, which can do so at practically no expense at all.

We have in mind a large road which decided it was not receiving its due share, and when the contract expired declined to renew, and has ever since been conducting its own advertising department, and with marked success.

Another, one of the largest systems in the country, will do so as soon as present contract expires, which will not be long.

Now that the time is approaching when many roads will be asked to renew is a good time to inquire what others are being paid, with a view to receiving a fairer proportion of these earnings, or even of conducting the business themselves and keeping the whole. There are several large firms which make a business of supplying reputable advertising to country newspapers, attending to all collection of bills therefor, and even guaranteeing their payment, which handle this work at a small commission, who would be equally willing to do the same for street car companies.

Your road may have a contract which cannot be improved, and again, yours may be one of those which think they have but for lack of proper study of the question have never realized their own value.

---

#### KNOCKED OUT THE PREACHERS.

In Peekskill, N. Y., the preachers banded together to oppose the granting of a franchise for an electric street railway. They were very much in earnest, for the road was intended to reach a summer resort. Looking into the future, the clergymen thought they beheld crowds of summer resorters riding on the cars on Sundays. At the meeting of the board of trustees the ministers with one voice proclaimed that God did not allow men to harness the electric fluid for such purposes, in order that they might add another to the many forms in which the sanctity of His day was violated. It was shown to the preachers that there was no church at the summer resort, and, as heretofore, there had been no way of reaching Peekskill except walking, the cause of small summer congregations was apparent. With means of transportation, the resorters would come to church, which would result in increasing the revenue and assuring ministers' salaries and other expenses. The force of the argument was so apparent that opposition was withdrawn, and a franchise granted to the Beach Railway Company.

---

#### JOHN WORTHY DEAD.

John Worthy, president of the Metropolitan Elevated Railway Company, Chicago, died, December 12, at the Murray Hill hotel, New York. Mr. Worthy had been in New York ten days. About a week before, a small pimple broke out between his shoulders, which developed into a carbuncle. A surgical operation was necessary, from which he did not rally. Mrs. Worthy and their son were with him. Mr. Worthy was also president of the Commercial Loan and Trust Company Bank. He was born in the county of Durham, England, August 12, 1841, coming to this country when he was 11 years old. His commercial life began with the coal business, but after the war, he entered the stone trade, in which he became wealthy and was interested at the time of his death. Mr. Worthy was a man who made no enemies, and was prominent in the affairs of Chicago.

---

J. W. Wheeler has been appointed receiver for the J. W. Fowler Car Company, Elizabeth, N. J.

# STREET RAILWAY PROGRESS 1894

While the progress of the street railway industry during 1894, has not been as remarkable as during some previous years, it has been of a substantial character. In common with other lines of trade the street railway business has been held back by the recent financial condition of the country. In spite of this there has been a progress that was made possible only by the fact that the electric railway business is probably growing more rapidly than any other great American industry. Not only is its growth in mileage remarkable but improvements in numerous mechanical and electrical details are being made daily. The panic has had the useful effect of preventing the building of many non-paying roads, and of checking the tendency that has existed for several years of placing fictitious values on electric railway properties. The industry will now go ahead on a firmer basis than ever before. That it received so slight a check during the financial stringency is one of the best proofs we have that electric road building will not be retarded until all the meshes of the steam road network over the United States are further divided by the finer network of the suburban and interurban electric road. In round numbers there are about 10,000 miles of electric road and 20,000 electric motor cars at present.

Electrically and mechanically the electric road has reached that state of perfection which puts it on a par with steam roads. The progress of 1894 along these lines has been principally in the improvement of details. The days of experiment have passed and the electric railway apparatus in use to-day is the result of an evolution in which the survival of the fittest is the rule just as truly as in biological evolution. A few years ago there was a great variety of apparatus in the market but the hard knocks of every day use have sifted out the good from the bad until certain types have been developed to which the majority of manufacturers conform. The general design of apparatus having been settled, an opportunity is afforded to perfect the details and it is to the perfection of details as much as to the general principles that the electric railway owes its success. Hand in hand with the perfection of details which has taken place during the last year has come a more substantial construction of everything used in street railway work, especially track and overhead lines.

Previous to this year the manufacture of electric railway apparatus occupied a peculiar position among the other industries of the country. The profits relative to the factory cost of apparatus were enormous and the ordinary laws of competition in trade did not seem to apply here. At the same time it may be said in explanation that the amounts spent in experimenting and in making sales were also enormous.

Why this condition of affairs existed for so long a time

under competition is difficult to explain. However, it was not until the latter part of 1893 that this state of the business began to change, and 1894 has seen a grand crash of prices that has entirely removed the basis upon which the manufacture of electrical appliances formerly rested. Electric railway appliances are now made and sold in very much the same way that other standard articles of manufacture are sold. That is, there is the closest competition and everything is figured on a small margin of profit. In fact it is said that many contracts are now being taken at a loss. During 1894, prices on railway motors have been cut in two, and while other apparatus has not taken so serious a drop the reduction is below what would have been thought possible last year. How long prices will continue at their present low ebb it is impossible to say but it is certain that they will never go back to where they were before the cut throat competition of the panic forced them down.

The most revolutionizing change in the electric railway field this year has been the increasing use of generators directly connected to engines. They were introduced to the public at the World's Fair and the number installed this year has exceeded the expectations of the most enthusiastic advocate of that type of apparatus. They are growing so in popularity that it looks at present as if it would not be many years before they are used on all new work. Not only are they being built in the large sizes, but in the smaller units. The largest railway power plants in Brooklyn, Philadelphia and Chicago are being supplied with them. One company has this year built and installed 36,900 horse-power of these generators and is building 20,000 horse-power more.

One important move made this year by railway motor makers was the lightening of the equipment by using cast steel or something closely allied to it, in place of cast iron. The movement was begun in 1893, by the appearance of the General Electric 800 motor. Early in this year the Westinghouse No. 12 appeared closely followed by the Walker motor. Both of these are light motors and have in addition to the improvement of decreased weight, devices for suspending the motor by springs and relieving the axle of its dead weight. About the middle of the year the Card and Steel motors were announced as on the market.

The electric welding of the joints on many miles of street railroad track has been a prominent feature of the year's work. The Johnson Company opened up the season by welding  $3\frac{1}{2}$  miles of straight double track at St. Louis. Some track was welded at Boston in '93 but about ten per cent of the joints broke near the weld. The method of welding was then radically changed and the work done in 1894 may be said to stand by itself as

an important experiment, the results of which we will know ere many days of '95 have passed. On the Nassau Railroad of Brooklyn, 32 miles of track have been welded. The Cleveland Electric Railway and the West End Street Railway of Boston, have also been favored with visits by the Johnson welding cars this year.

Another method of making continuous track was discovered by A. Hoffman, now of the Falk Manufacturing Company, Milwaukee. His process is one of casting iron around the rail joints and it seems to have good prospects of being a success. Three miles of track have been supplied with these cast joints at St. Louis and the coming winter will test this track as well as that electrically welded last spring. The casting process was first publicly shown at the Atlanta street railway convention in October.

A notable addition to the list of practical railway appliances is the Sperry electric brake. The inventor has been working on this brake for many years, but it has not been put forward for commercial use until this year. This brake has probably attracted more attention than any other single electric railway device brought out this year because it is such a radical departure from any previous commercial braking apparatus. The interest was not lessened by the fact that Mr. Sperry waited until the brake was an assured commercial success before announcing his work to the technical world.

About October 15 work was begun on a section of conduit electric road for the Metropolitan Traction Company of New York, by the General Electric Company. This is notable as being the first electric conduit road to be built for commercial operation by any large American electrical manufacturing concern. The principal manufacturing companies have in times past been too careful of their reputations to get tangled up in any underground conduit roads except in their own experimental yards. Although the New York conduit has the best prospects of success of any system yet laid there is no probability that such a success will create the revolution in electric railway practice that some expect, as its cost is enormous, being greater per mile of track than that of the cable system. This being the case, its use will be limited by commercial considerations to very heavy traffic, such as is served by the cable and hence it will never come into very extensive use, though it may serve a limited field.

The first application of the "booster" to electric railway feeder lines has been made on the Poughkeepsie City & Wappingers Falls Electric Railway. It is used to raise the voltage on a ten mile feed line.

The use of T rail in paved streets has been more prominently brought to public notice this year than ever before and it is now recognized as a reliable and established form of track construction.

The three wire system has been operating for several years on two or three roads of the country. The results were first publicly announced this year through the columns of the REVIEW and considerable interest aroused.

The year has been one of great activity in electric railway construction in Brooklyn, Philadelphia, and Chicago. Brooklyn has been putting the finishing touches on its extensive systems. Philadelphia has undergone a great transformation which was begun last year and is yet to be finished. The general upheaval of Chicago horse lines did not begin until half of '94 was gone, but taken altogether it is probably safe to say that the work of changing over is now about one-half accomplished. However, this does not mean that half the electric lines are opened for traffic.

In May, the Metropolitan West Side Elevated Railroad of Chicago announced its intention to use electricity. The result created quite a jubilee in electrical circles, especially in Chicago, as this project together with the changing over of the horse surface lines will combine to make Chicago as prominent an electric railway center as it now is a commercial center. The contracts for the electrical machinery for this road were let about July 1. Within the last month the formal announcement has been made that the Lake Street Elevated Railroad of Chicago will soon adopt electricity. The change is to take place early next year. This road was recently bought by the Yerkes syndicate which controls the north and west side surface lines, so that the announcement is no great surprise. The Northwestern Elevated soon to be built on the north side will also be an electric road.

Taken as a whole, in view of the unfavorable conditions, the record of the year is a very creditable one, and as compared with new work in the steam railroad field is specially gratifying. With restored confidence, and the accumulated demands for extensions and new lines which have been gathering for nearly two years, and the conditions of a steadily improving money market the outlook for 1895 is certainly a bright one.

#### ROBINSON'S RAIL BOND.

F. Foley Robinson, an English electrical engineer, has invented a bond which has terminals of tubes, which are expanded to fit the holes in the rails in the same way that

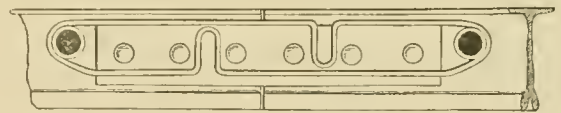

NEW RAIL BOND.

boiler flues are expanded. The principle of the terminals is the same as that of the Chicago rail bonds, now so well known in this country, but instead of being one piece the tubes are connected with some sort of conductor, so that four joints are involved in each bond.

DURING the fiscal year ending October 1, the Springfield (Mass.) Street Railway Company has built forty-six miles of new track, laid T rail, made 179,061 round trips, run 1,490,451 miles, and carried 7,225,197 passengers. Sixteen new cars were added.

### LOOP FOR CHICAGO L ROADS.

After much talk, incorporation of several companies, considerable rivalry and many refusals to go into such a scheme, the four elevated railways of Chicago have decided to use a union loop. The terminals of the companies for geographical reasons have been necessarily placed at points several blocks from the business center of the city. All of them have greatly desired to come down town, but have found many obstacles to overcome, the principal one being the objection of property owners to a separate loop for each company. Ordinances have been passed by the city council granting franchises for loops, but the only company that has taken steps to construct one is the Lake street, which put down foundations and columns in May, or June, but has done nothing since.

As the Metropolitan road was drawing near completion, steps were taken to secure a loop. A combination was made with the Alley L Company, which resulted in the incorporation of the Chicago Central Railroad Company with \$3,000,000 capital. The incorporators were John Worthy, president of the Metropolitan; Marcellus Hopkins, president of the Alley L; Herman Benze, right of way agent, Joseph Keffer, cashier and Addison L. Gardner, local attorney for the Metropolitan; and Eugene Klapp, chief engineer, and Edward A. Nichols, attorney for the Alley L.

The same day was incorporated the Union Elevated Railroad Company with \$5,000,000 capital, by those interested with Mr. Yerkes, viz., D. H. Louderback, Egbert Jamieson, John B. Parsons, John A. Rose J. William Helm, Le Grand Perce, Edmund Furthman, Edward Koch and L. D. Condee. This company will build the loop. An agreement has been reached between the officers of the Metropolitan and Alley L companies on one hand and Mr. Yerkes, by which the

latter will build and control the loop, while the other companies have the privilege of running over it. The route as projected, will be on Lake street from the terminus of the Lake Street L line to Wabash avenue,

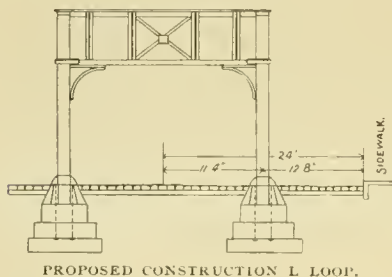

PROPOSED CONSTRUCTION L LOOP.

south on Wabash to Harrison, west, crossing the Alley L, to Pacific avenue, north to Van Buren, west to Market, north to Madison connecting with the Lake Street L terminal at that point. Plans have been prepared, which seem to meet with favor from the property owners, who are apparently willing to give consent to only one loop.

The structure will be very light and will, it is said, interfere with the light in the stores little, if at all. The supporting posts will be placed twelve feet eight inches from the curb line in the street, coming just outside the double street car track. It has not been definitely decided

where stations will be placed, but it is expected there will be three on Lake street, and six on Wabash avenue, no plans have been made for stations on other streets, but they will be placed about every two blocks. The illustration is a sectional view showing location of columns with reference to curb lines and sidewalks.

### GEORGE W. MYERS.

George W. Myers, secretary of the Lewis & Fowler Manufacturing Company, Brooklyn, N. Y., is a young man to hold such a responsible position with a concern of such magnitude. Mr.

Myers has earned his present position by hard work, which has been appreciated and rewarded by his employers. He was born in Brooklyn, in 1862, his early life being the same as most boys. The public schools furnished him with the foundation of his education, which was completed, as far as institutions of learning go, in the Adelpia academy, and one year at the scientific school of Yale University. Seven years ago he entered the employ of the Lewis & Fowler Manufacturing Company, as auditor and cashier. In this position Mr. Myers soon developed the faculty of mastering details, which made him a valuable man in the service of the company. In January, 1893, he was elected secretary of the company, which was a well deserved promotion, showing the appreciation of his employers in his hard work and his integrity.



GEORGE W. MYERS.

### COMPRESSED AIR AT WESTFIELD.

The Compressed Air Car Company has leased the Woronoco Street Railway Company, Westfield, Mass. The street car line will be extended, and will be used for testing cars before shipment. A large plant will probably be built. The company is to pay an annual rental of \$2,000 for the street railway line, which is practically five per cent of the capital stock of \$25,000 and its \$16,000 debt. The capital of the compressed air company will be increased to \$100,000. Westfield will secure the plant, if the citizens take half the capital stock.

Edward Ash, superintendent of the Schuylkill Traction Company, Shenandoah, Pa., has become a benedict. Miss Anneta Buckwalter was the happy bride.

## CAST-WELDING RAIL JOINTS.

The New Process of Making Continuous Track—A Promising Rival of Electric Welding—Three Miles Laid at St. Louis.

Like a thunderbolt out of a clear sky came the announcement, several months ago, that the Falk Manufacturing Company, of Milwaukee, would soon come forward with a process of welding cast iron around rail joints which would make a continuous track and seri-

and how anxious street railway men are to find something that will do away with those everlasting nuisances, the rail joints.

Immediately after convention, work began at St. Louis, and the joints have been cast on about three miles of track there. This track was laid some time ago, with common angle bar joints but no traffic has passed over the road except that of teams so that the track is practically new and on an equal basis with the electric welded track laid last spring. Besides that mentioned, 37 joints which



READY FOR WORK.

ously compete with electric welding. It was the suddenness with which this process came forward that startled the electric railway world. It is not often that any industrial method comes so absolutely without warning and apparently without any evolution. The usual course is a long series of experiments and investigations before even an attempt is made in a commercial way. Then after the commercial application begins there is a still further evolution.

The process was shown at the Atlanta convention, and the constant throng of visitors which crowded around the place where the work was going on, and prevented many from seeing as much as they wished, showed how vitally important the work was considered to be

have broken on the six miles of electrically welded track have been repaired by the cast-welding process. The latter work was done in two evenings' work of three hours each. The accompanying engravings show the work in progress.

The outfit used is nothing more than a small foundry cupola for melting the iron, mounted on wheels. This cupola wagon weighs 7,000 pounds complete and is easily drawn by two horses. The one used at St. Louis and shown in the engraving made 60 joints a day. The Falk Manufacturing Company is now completing several which will have a capacity of from 140 to 200 joints a day. The coal and coke box is located just behind the driver's seat. The cupola is hung on pivots similar to a

mariner's compass so that it is always kept level even though the wagon may be standing on a grade. Behind the cupola is a small steam engine with a water tube boiler. The engine takes care of itself to a large extent as the water feed is automatic being regulated by the height of the water in the boiler. The oil fuel flow is regulated by the pressure of steam. The engine drives a blower for furnishing an air blast to the cupola. The air pipe between the blower and cupola has a flexible

a pair. Before the molds are applied the rails near the ends are cleaned and if the ends do not butt together closely a thin section of rail is driven in to fill the crack. The molds are then put around the joints. The iron is then poured in the molds from a ladle as in an ordinary foundry. The union between the iron and steel of the rail is similar to that which takes place in a good weld and hence the term cast-welding is applied to the process by the Falk company. Sections through joints and



METAL RUNNING.

joint to allow for the movement of the cupola on its pivots. Under the engine can be seen the tank for water supply.

In operation the first thing, of course, is to dig up the paving and expose the joints. Meanwhile the molds which are of common cast iron are thrown in a heap somewhere near by and a fire built around them so that by the time they are to be put around the joints they are a dull red. The molds are lined with a composition of graphite and another substance the nature of which is not given out. This composition is applied with an ordinary paint brush. The molds are relined in this way for about every 20 joints cast in them. They can be lined while hot and it takes about half a minute to reline

pieces of casting broken off show that the same state of union exists as with a good weld.

As shown in the engravings the molds have eyebolts so that they can be handled with iron hooks. They are held in place with ordinary clamps and are of such shape as to fit up snugly against the rails and hold them firmly in line until the joint has cooled. As shown in the engravings the cracks on top between molds and rails are filled with clay and sand. A plate of iron is laid over the crack between the ends of the rails so that when the iron attempts to rise there it is suddenly chilled and prevented from flowing out on top of the rail. Underneath the molds the crack between the halves is closed by holding a pan of sand up against it. The



molds can be put on a joint in about two minutes. As said before the molds are hot when put on and they are allowed to stay on long enough to heat the rail ends. After the iron has been poured in about ten minutes is allowed to elapse before the molds are taken off and put on another joint. About a dozen sets of molds are kept in use at once. Every other joint of a section of track is cast in the morning and in the afternoon the remaining joints are cast. This is to prevent, as far as possible, the severe strain of contraction and expansion. When the the joint is hot it heats the rail for some distance on each side and consequently there is considerable expansion. There is a corresponding contraction when the joint cools. The effects of this were feared enough so that the above



FILLING MOLDS.

also requires from 250 to 300-horse-power from the power station. While on a large system this is easily provided for, it is a seriously large item for a small road. When construction work is being rapidly pushed the fact that the trolley wire does not have to be strung before the track is completed will prove an advantage as well as the rapidity of the cast-welding process. With the casting method there is no heavy welding machine to run over and bend the track out of shape before the joints are set. There are not many roads that can afford to keep on hand a welding machine for mending broken joints and doing odd jobs around a system, but a cupola large enough to do such work can be supplied at a cost of less than \$1,000, so that there need be no angle bar joints on an entire road. No special skill is required on the part of the men employed except the man who runs the cupola. Electric welding, especially of steel, is as is well known, a process in which the skill and experience of the operators plays a vitally important part. The facility with which broken and defective joints are repaired by the cast-welding process is an important point. Defective joints will appear with both systems. The question is how best to handle them. With electric welding it is necessary to saw out the joint (if the break is such that it can not be repaired by re-welding) and insert a new section of rail which requires two joints

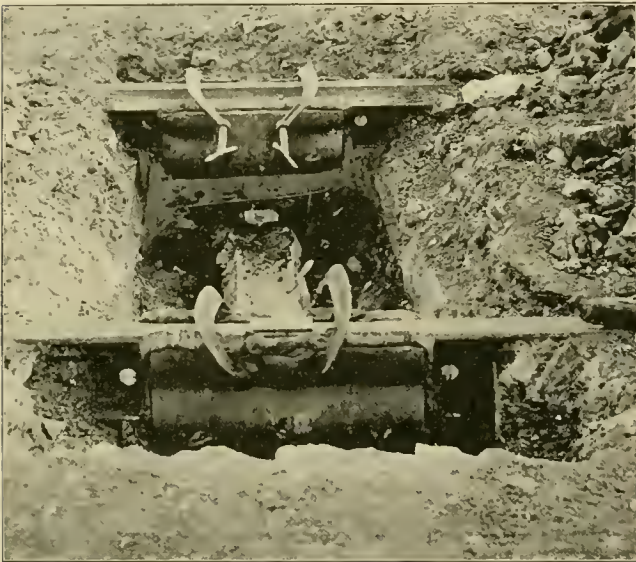

MOLDS ON JOINTS.

method has been used to prevent the strain to some extent.

The joint made at St. Louis weighed 120 pounds. The joints can, of course, be made of any weight. Those made by the company at first weighed 54 pounds. The 54-pound joint placed on blocks two feet apart has when tested stood a downward pressure of 100,000 pounds. The 120-pound joint covers four bolt-holes. The material used is common cast iron with a secret composition mixed therewith. The cast iron is selected with a view to great tensile strength. The cost of a joint is about \$3.

In the engraving showing the wagon and force of men employed on the work there are about eight who are employed in the actual operation of running the cupola and casting the joints. The rest are for digging up the pavement. Iron is unloaded along the street at the places where it will be needed.

If it is found to stand the test of time this process will have some marked advantages over electric welding. In the first place the initial cost of apparatus is nowhere near that of an electric welder, and it is also much less delicate and costly to maintain. The electric welder

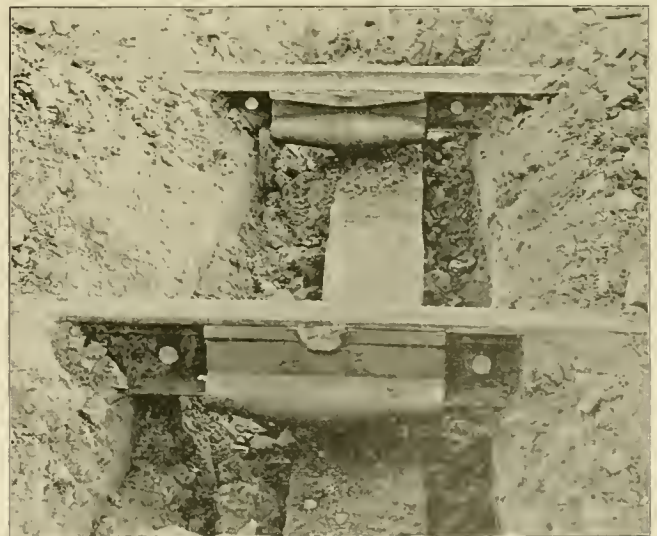

JOINTS FINISHED.



CUPOLA AND CREWS.

where one was before. With the cast-iron joint it is only necessary that the top or ball of the rail be continuous. If it is not continuous a short piece can be put in and the mass of metal cast around the break will make a good joint.

A peculiar feature of the cast joints as now made is that the welding action between the rail and casting takes place around the base and about two-thirds of the way up the web of the rail but not around the head and upper part of the web. This is as it is intended to be because if the joint is defective and breaks, the head of the rail remains intact. The manner in which the non-welding of the upper part is accomplished is interesting. When the iron is poured the quantity of melted metal around the base is so great that it heats that part of the rail nearly to its own temperature and a union takes place between the metals. In the upper part of the joint the small mass of hot metal is not sufficient to heat the head and upper web hot enough to make a weld.

The Falk company is confident that the continuous rail will prove a success, but in case it does not they have another plan to fall back on which would still make a very superior joint. By painting the rail with a secret liquid before the metal is run in, the welding action is prevented and a solid mechanical joint is made, which allows for contraction and expansion. It should be said here that the failure of the few joints mentioned on the electrically welded track of the Baden Railway at St. Louis is not to be taken as pointing against the use of continuous track, as the joints which broke were defective and not fair specimens of the electric welding process.

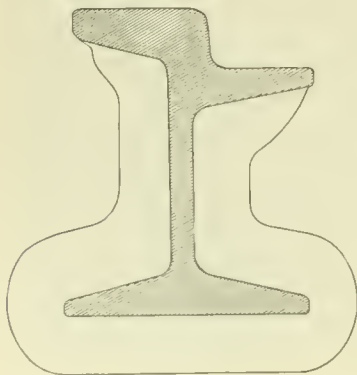

54 POUND JOINT.

The accompanying engraving, which is of one of the lugs knocked off of a broken electrically welded joint, shows that welding took place only at two or three places of small area. The lugs on the defective joints were knocked off with a light sledge.

The results at St. Louis will be awaited with intense interest and the outcome of the winter's trial means much to the street railway business.

To Captain Robt. McCulloch, general manager of the National Railway Company's lines, of Louis, is due the thanks of the entire fraternity, for his zeal in experimenting and sifting the continuous rail problem to the bottom. He has shown the same progressive spirit in this as in many other matters relating to street railway welfare, and the fraternity is to be congratulated on having him as a member.



LUG KNOCKED OFF DEFECTIVE ELECTRIC WELD.

#### NEW COMPANY IN DETROIT.

The Detroit Railway Company, recently organized by H. A. Everett, of Cleveland; Albert Pack, of Detroit; Green Pack, of Oscoda, Mich., and George W. Pack, of Ashville, N. C., was granted a franchise November 28, by the Detroit city council, to build forty miles of electric railway on twenty-seven miles of street. The vote in favor of the ordinance was twenty-nine to one. Fares will be three cents. Track-laying will begin April 15, it is said. A deposit of \$50,000 has been made to guarantee construction, completion and operation of all lines within the coming year. The cost is estimated at \$1,500,000. An agreement has been made with the Fort Wayne & Belle Isle Street Railway Company permitting the new company to transfer its cars over that company's lines to the union depot.

FRANCIS J. CALLANAN, treasurer of the Union Traction Company, of New Jersey, a new road recently incorporated, was killed while attempting to board a moving train at Rutherford, N. J. He started as a boy in the Midland line, Utica, built the Peoples' line, Syracuse, bought the Oswego Street Railway Company, and organized the Peoples' Railway Company, Brooklyn, and the Union Traction Company, of New Jersey, which will build from Newark through Rutherford to Hackensack.

## STREET RAILWAY LAW.

EDITED BY FRANK HUMBOLDT CLARK, ATTORNEY AT LAW, CHICAGO.

*Injury to Passenger Riding on Step of Car.*

A Passenger on a street car, who, on the invitation of a person in charge, or without objection from him, stands on the step of the car, outside of the gate, is not negligent per se, as the danger of such a position is not so obvious that it could be said that a reasonable man would disobey the invitation or direction.

At the time of the accident, the defendant was converting its horse railroad into a cable road. The plaintiff had been engaged in finishing up the new track by putting gravel between the paving stones at a point near Taylor avenue, which was about three-fourths of a mile west of the place of the accident. The plaintiff was in the employ of contractors, and not of the defendant. At 5 o'clock in the evening he took a car going east. According to his evidence, he got on the car when it stopped at Taylor avenue. It seems the car was full of passengers, so that there was neither sitting nor standing room on the inside. He first went to the rear platform, but found so many persons standing on it that he could not get on. He then went to the forward platform, and found that crowded with passengers. There was an iron gate at the front platform, extending from the outer side of the car, across the platform to the dashboard, and the gate extended down to within a few inches of a step leading up to the platform, which step extended out six or seven inches beyond the outer line of the car. He and another person, by the name of Kelly, stood on this step. When they reached Sarah street, the plaintiff was struck by a projecting timber of a derrick standing on the street, and was knocked off.

The defendant company had nothing to do with this derrick. It was a large contrivance used by contractors in constructing a sewer, and was moved along as the work of the sewer progressed. It consisted of timbers, pulleys, a track, and a dumping apparatus. The end next the car was about four feet high, and the other end much higher. At the lower end a timber projected out within ten inches of the passing car, and it was this projecting timber that struck the plaintiff.

It is conceded on all hands that the plaintiff was a passenger on this car, and the question is whether, as a matter of law, he was guilty of contributory negligence in riding on the step on the outside of the gate. The law is now well settled that it is not negligence per se on the part of a passenger on a horse car to ride on the platform, and this is true whether there is or is not room in the car. There can be no doubt but riding on the step or platform of such a car is attended with more danger than riding in the car; and if a passenger will take a position upon such a place in violation of the rules of the company and the warning of its servants in charge of the car, he is guilty of negligence. Here the closed gate was itself a warning that this front platform was not a proper place to stand. Nothing more appearing than this, that the plaintiff took his position on the step,

with the closed gate between him and the platform, and that he was knocked off by coming in contact with the derrick, and we should have no hesitancy in upholding the ruling of the trial court. But what are the additional facts? Though this car was crowded with passengers, it stopped at Taylor avenue, and this was an invitation to the plaintiff and others to get on, no contrary announcement being made. Indeed, there is certain evidence tending to show that some ladies got on at that place. The plaintiff and Kelly took a position on this step of the front platform, for want of room elsewhere, and this, too, with the knowledge of the driver. Having gone one or two blocks, they, by the driver's direction, took out the gate, but could find no standing room on the platform. The driver then directed them to put the gate in place, and stand on the outside, and this order they obeyed, and were thus carried for a half mile before the accident. In short, the plaintiff was received as a passenger, and was by the driver permitted and even directed to take this position on the step outside of the gate, and it cannot be said that the plaintiff was, as a matter of law, guilty of contributory negligence. A passenger has no right to take a position, even at the direction of the servant, which is obviously dangerous; and in such case the direction of the servant will be no excuse. Standing on the step of the car cannot be said to fall within this principle. The danger of such a position is not so obvious that it can be said a reasonable man will disobey the invitation or direction.

The evidence of the plaintiff shows that he knew parties were constructing a sewer at Sarah street, and that he had seen this derrick in the street when passing to and from his work. The defendant's track had been moved over towards the derrick on the morning of the day of this accident. There is nothing in these circumstances from which the court can say the plaintiff was, as a matter of law, guilty of contributory negligence in failing to see the derrick.

There is also evidence tending to show negligence on the part of defendant. The track was placed in this position near the derrick on the morning of the day of the accident, and the defendant must have known of its proximity to the cars. With such knowledge it became the duty of the defendant to use all reasonable care to avoid exposing passengers to danger, and especially is this so in view of the fact that passengers were allowed to stand on the side steps of the car.

The defendant pleads as a defence an act which provides: "Said railroad companies shall not be liable for injuries occasioned to persons by their getting on or off the cars, at the front of or forward end of the car." Surely the statute cannot and does not apply to a case like the one in hand, where the passenger, at the time of the injury, was not getting on or off, but was riding on

the steps of the platform, with the knowledge and by the direction of the driver.

(Supreme Court of Missouri. *Seymour v. Citizens' Railway Company*. 58 American and English Railroad Cases, 395.)

*Sleigh Standing near Track—Care Required of Car Driver.*

Plaintiff was driving his milk sleigh; he stopped and took a can of milk from it into a sleigh standing alongside. Plaintiff's sleigh stood very near the track. As he was lifting the can out, with his horse headed towards the west, a two-horse car came from the west, and before he could put the can into the other sleigh, the car struck his sleigh, overturned it, and injured him. As he saw the car nearing his sleigh, he threw the can into the other sleigh and reached for his lines. He knew that the car was coming, and that it overhung the track, and that his sleigh was so close that it might be struck. The driver of the car saw plaintiff's sleigh, but drove on without making any stop.

It was a question of fact for the jury to determine whether the plaintiff, under the circumstances, should have been out of the way when the car reached that point, or whether the accident occurred wholly by reason of the negligence of the driver of the car. He could have stopped his car and avoided the injury. If he saw the plaintiff could not get out of the way in time to avoid a collision, it was his duty to stop. It is contended by defendant's counsel that, by the ordinance by which the road is operated, the car is at all times entitled to the track. It is true that under this ordinance parties driving upon the street car track, or so close to it as to impede the progress of the car, are bound to turn out and give the car the right of way, but this ordinance does not give railway companies the right, by their drivers, to run any vehicle down and injure the person or property of another, under the circumstances stated in this case. The plaintiff's claim was that when he did see the car coming, he made every effort possible to get out of the way. His sleigh was in full view of the driver, and if the driver saw that he could not get out in time, he should have stopped. Whether the plaintiff was guilty of negligence in remaining there the length of time he did, or in not having seen the car sooner, was a question for the jury.

(Supreme Court of Michigan. *Laethem v. Ft. Wayne & B. I. Ry. Co.* 58 Northwestern Reporter, 996.)

*Duty to Signal Cars to Stop.—Boarding Front Platform.*

It is the duty of a person seeking to take passage on a street car to signal the person in charge, and if, without signalling, he attempts to board a moving car, he cannot recover for the injuries thereby sustained.

An attempt to board the front platform of a street car running at the rate of seven or eight miles an hour, is such negligence as will preclude recovery, and an instruction to that effect is not prejudicial to a plaintiff who contends that the car slowed down in response to his signal, and that when he was about to jump on the rate

of speed was suddenly increased, since if its rate was not reduced and the car was proceeding at its ordinary speed, there was no negligence on the part of the company, and the injuries must have been sustained by the attempt to board a car moving so rapidly.

(Washington Supreme Court. *Woo Dan v. Seattle Electric Railway & Power Company*. 58 American and English Railroad Cases, 195.)

*Boy Boarding Car—Damages for Wrongful Expulsion—Wilful Injury.*

A complaint for personal injuries to the plaintiff, a boy 13 years old, which set forth that, desiring to ride as a passenger on one of defendant's cars, he stepped upon the platform thereof, intending to enter and pay his fare, when the conductor, without cause or warning, wilfully and with great force threw him upon the street, while the car was running at great speed, does not state a cause of action for a breach of the contract of carriage, but sets forth facts constituting a cause of action for wilful injuries inflicted by a servant acting within the scope of his employment.

In such an action the plaintiff cannot recover upon proof of mere negligence, however gross, and he is not obliged to prove his freedom from negligence, as his right of recovery is solely for the wilful injury.

In determining whether or not the injury was wilful, the jury may consider the other circumstances of the case, the manner of the conductor, the force, if any, used by him, and the effects of his acts, together with the presumption that every person intends the probable and natural consequences of his acts, and the unlawful intent may be inferred from conduct which shows a reckless disregard of consequences and a willingness to inflict injury by purposely and voluntarily doing the act with knowledge that some one is in a situation to be unavoidably injured thereby.

If the company's servant, in expelling the plaintiff, inflicted injuries complained of, in a fit of oppressive malice, or acted in such a manner as to indicate a heedless disregard of consequences, plaintiff may recover exemplary damages.

(Indiana Supreme Court. *Citizens' Street Railway Company, of Indianapolis v Willoebey*. 58 American and English Railroad Cases, 485.)

*Excessive Speed of Electric Car—Inattention of Motorman—Horse Going on Track.*

An instruction that if the motorman in charge of a street car could, in the exercise of reasonable care, have seen the plaintiff in time to have checked his car, after plaintiff's horse sprang upon the track and before the car collided with plaintiff's horse, and if plaintiff was not guilty of negligence which contributed to his injury, then the defendant would be liable, held properly given, qualified as it was by an immediately preceding instruction that if the injury resulted from the sudden fright of plaintiff's horse by reason of which said horse sprang in front of the moving car, and if the motorman, in the exercise of reasonable care, could not have checked the car in time to have prevented the collision, the defendant would not be liable, these alternatives presenting, as they did, the only disputed propositions of fact involved.

Street railway companies have no such proprietary interest in that portion of the streets upon which their tracks are laid as limits the right of the general public also to use the same territory as a part of the public highway. Whether an injury resulting from such joint use is attributable solely to the negligence of the railroad

company, or is wholly or in part imputable to contributory negligence of the person by whom injury has been sustained, is a question of fact to be determined by the jury.

(Supreme Court of Nebraska. Omaha Street Ry. Co. v. Duvall, 58 Northwestern Reporter, 531.)

*Injury to Section Man—Riding on Car Step.*

Where a section man of a street car company whose trains were drawn by a steam motor was ordered by the foreman to take passage on one of its trains and not to get on "so as to bother the passengers," the question of his contributory negligence in riding on the front platform with his feet on the step is for the jury.

A conversation between the plaintiff and the engineer of the motor concerning the situation the plaintiff took on the front platform of the motor, was admissible to show that the engineer knew of plaintiff's position.

Plaintiff may recover for the injury to which his

**BLAKISTONE'S COMBINATION CAR FENDERS.**

George Blakistone, president of the Central Railway Company, of Baltimore, Md., has invented a fender attachment for his cars, which has received the approval of the Baltimore Car Fender Commission as complying with all requirements of the city ordinance. The practical value of this fender has been demonstrated in a year's service on the cars of the Central Railway Company, during which time many lives have been saved and not a few damage suits avoided.

The appearance of the front fender is well shown in the illustrations given herewith. A netting of stout rope is stretched upon an iron framework, which is hinged to the car and held up by two chains hooked on the upper edge of the dashboard. The front edge of the fender is flexible. In addition to the front fender the car is provided with two wheel guards. These guards can be



BLAKISTONE'S FENDER—CENTRAL RAILWAY COMPANY, BALTIMORE, MD.

negligence contributed, if defendant, knowing his position, could have averted it by using ordinary care.

Where plaintiff was injured by having his feet caught between the step of the car and an embankment, the fact that he might have saved himself by stepping on the platform, does not show contributory negligence, when he had very little time in which to act.

(Supreme Court of Colorado. Denver, etc., Rapid Transit Co. v. Dwyer, 36 Pacific Reporter 1106.)

THE receiver of the Orange Mountain Cable Company, Trenton, N. J., has filed his report, showing liabilities \$767,734.69; assets \$180,782.26. The daily loss during October was \$5.89. The receiver has asked the court for permission to issue bonds and operate the road.

THE City Electric Company, Decatur, Ill., has a special policeman to arrest boys who jump on and off cars. Recently while the motorman was inside collecting fares, boys locked the front door, and turned on the current, and jumped off. The motorman rushed to the rear platform and pulled down the trolley before damage was done.

lowered and raised by the motorman without leaving the platform. It is dropped by the motorman touching a pin in the floor of the platform, or by an automatic trip which is connected to a light board or frame hanging down within a few inches of the track.

In Fig. 2 the fender and guard are shown in the positions they occupy while the car is running upon an unobstructed track. In this position both the fender and the guard are carried eight inches above the track.

In Fig. 3 the wheel guard is lying on the track, a position which follows when the front fender has passed over an object, or when the hanging trip board strikes an object, or when the motorman has pressed with his foot the pin in the platform floor. The guard is pressed down by strong springs, thus incidentally acting as a track brake of considerable power.

In Fig. 1 the front fender is shown drawn up out of the way preparatory to entering the car barn.

A man standing on the track is first struck on the ankles and thrown into the front fender, where he rides safely until the car is stopped. In case the person is lying down on the track, the front fender passes over

him, rising as it does so, and trips the wheel guard. The victim is then gathered up into the net of the wheel guard and not pushed along the pavement to be bruised and lacerated. When the projecting front fender is not in use the wheel guard is tripped by the hanging board. The provision is valuable, as there are serious objections to the use of projecting fenders. In Blakistone's fender these objections are minimized, it being light in weight, easily and readily movable from end to end, easily folded up, and, best of all, it passes over a man lying on the track, and does not crush him in a vain effort to pick him up.

### ELECTRIC HEATERS FOR THE METROPOLITAN ELEVATED, CHICAGO.

The most notable victory that electric heating has made since its beginning is the contract for the heating of all the cars of the Metropolitan West Side Elevated

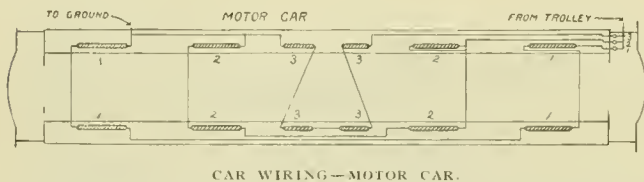

CAR WIRING—MOTOR CAR.

Railroad of Chicago, which was recently awarded to the Central Electric Heating Company of New York, the maker of the "American" heater. There are still a

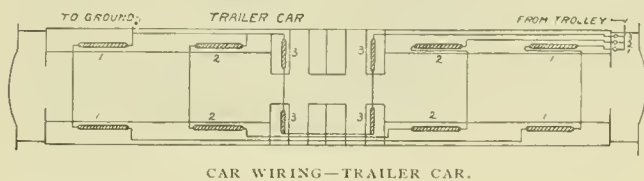

CAR WIRING—TRAILER CAR.

few people that believe electric heaters to be nothing more than expensive toys, but when it comes to the heating of elevated railway trains it looks as if the toys were getting to be rather practical affairs.

The first lot of cars to be equipped will be 55 motor



STYLE C HEATER UNDER CROSS SEATS—METROPOLITAN ELEVATED.

cars and 100 trailers. These cars are all 38 feet 8½ inches long; 7 feet 10 inches wide; center height, 8 feet 6⅞ inches; side height, 6 feet 7¾ inches. The capacity is 2,233 cubic feet, and the total glass surface is 208 square feet. As shown by the accompanying diagrams of car wiring, each car will have twelve heaters. These are connected four in series, and each of the three series is on an independent switch. With all the circuits in so as to get the maximum heat, the car heating will take

7,000 watts or 14 amperes at 500 volts. Eight heaters will be placed under the side seats, which are to be 34 inches long, 7 inches high, and 2½ inches wide. The other four are smaller, being 21 by 7 by 2⅛ inches. Each series of the larger heaters takes 2,600 watts and the four smaller 1,800 watts. It is estimated that with all the heaters in, the car temperature will be kept between 55 and 60 degrees Fahrenheit, when that outside is from 0 to 10 degrees. This will be the largest application of the electric heater yet made, and will, no doubt, be a great help toward their general introduction.

### ODEN BOWIE DEAD.

Ex-Gov. Oden Bowie, president of the Baltimore City Passenger Railway Company, died at his home, December 4, of paralysis. Mr. Bowie, who was 68 years old, had an active life, which was spent in Maryland, his native state. He served in the Mexican war, being promoted from private to captain on account of his bravery and ability. Before he was 21 he was a candidate for the legislature, but was defeated. Coming before the people the next year he had better luck, and continued active in politics until 1867, when he was elected governor. In 1860 Mr. Bowie was elected president of the Baltimore & Potomac Railroad Company.



ODEN BOWIE.

Governor Bowie's street railway connection began in 1873, when he was elected president of the Baltimore City Passenger Railway Company. During the summer, while the line was being operated with horses, he stationed men at short intervals with buckets of water, whose duty it was to sponge the horses. This was the result of his fondness for that animal, which caused him to keep a great many, and for twenty years he was one of the most successful breeders of racing horses in the world.

### WESTERN ENGINEERS' EXCURSION.

The November excursion of the Western Society of Engineers occurred November 17 and was full of pleasure and profit for those who found time to participate. The excursion occupied a day, as is customary, and the industrial works of South Chicago were visited. The Illinois Steel Company, Iroquois Furnace Company, Chicago Shipbuilding Company, and Morden Frog and Crossing Company were on the list. It is safe to say that nowhere in the west can the iron industry be studied better than at South Chicago. The trip was one of unusual interest to railway men, because it gave them an insight into the production of a class of supplies of which they are large consumers.

PAID HIS TURKEY'S FARE.



TALL, solidly built, well dressed man, with a good natured face, who had been drinking just enough to make him feel jolly, got on an Eighth street cross-town car near Sixth avenue, New York, carrying in his arms an immense turkey. He sat the turkey down in a corner seat and then said:

"Conductor, see that turk?"

He's mine."

"Yes, sir," answered the conductor.

"Well, I'm going on the front platform to smoke, and I want you to take care of the turk till I come back. See?"

"Certainly, sir."

"The turk will not disturb any one, and no one must disturb him; and to avoid all trouble I will pay his fare," and he did so, while the conductor laughed.

"Great Hivvins!" said a man with red whiskers, who was seated next the bird; "I nivver heard on the loikes av that—paying carfare for a turkey."

The owner of the turkey then went out on the front platform, while the bird sat in a dignified manner in the corner. Passengers continued to come in, and the man with whiskers was crowded nearer the turkey. "Don't crush him, gintlemin," he said. "His fare has been paid and he is entitled to a sate."

The conductor evidently thought the man with red whiskers had too much affection for the turkey, for he looked into the car every now and then to see if his charge was safe and unmolested.

"Hully gee!" exclaimed a tough young man opposite the bird. "Think of a bloke blowin' in de price of a skillet of beer on a dead turk! Some blokes must have more money dan de Astors ter pay car fare for er gobbler. Hully gee!"

When the car reached Second avenue the owner of the turkey came in, picked it up in his arms, said "much 'bliged" to the conductor and got off.

"It wur a foine burd," said the red whiskered man, with a sigh, "an' I was a-hopin' he'd forget it. If he had there would have been a raffle at O'Brien's Thanksgiving eve as would have done yer heart glad to see."

TOUCHED A LIVE WIRE.

H. Herbert Hutchins has secured a verdict of \$1,000 against the Denver Tramway Company, having sued for \$10,000. He alleged that some time ago he was riding on the back platform of a car, when he felt himself being suddenly jerked backward, as it was rounding a curve. In order to prevent himself from falling, he reached out his hand, and grabbed what he thought was a piece of cord. He happened to catch hold of a piece of live wire, which he testified, "knocked him silly," from which he has never recovered.

AN INGENIOUS SNOW PLOW.

On the Richmond City Railway Company, Richmond, Ind., is an ingenious snow plow, the invention of E. Kessler, electrical superintendent. On a Bemis truck is mounted two W. P. 50 motors. A frame of 8-inch by 10-inch timbers, on which are laid sills of 8-inch by 10-inch by 24 feet, is bolted to the truck frame. Upon the sills is a floor with two traps for access to the motors. The body is vestibuled at both ends, so that the operator is inside. The plow blade is 2 inches by 18 inches by 10 feet long, standing 45 degrees to the track, with a hoist of 10 inches. It can be set at any distance from the rail by the tightening of four chains.

The rail scrapers are four T. H. trolley bases, one at each corner of the car, inverted in order to get the tension on the rails. Round iron plugs welded on spring steel 1/2-inch by 3 inches wide, are inserted in the trolley bases. The steel is bent to right angles on a gentle



INGENIOUS HOME MADE SNOW PLOW.

curve at a point 2 feet 6 inches from the trolley base. At the lower end of the steel shanks are applied steel shovels 6 inches by 8 inches by 1/2-inch, the face being formed to fit the top and sides of rails. In the shovels are mold boards 14 inches by 30 inches, which throw snow or any other obstruction caught by the scraper, to the outside of the track. The mold boards do not appear in the illustration, as they were removed. It was intended to add a salt spreader, but a separate car was built and is used as a trailer.

The rail scrapers, invented by Henry E. French, assistant electrician, who has patents pending, were used last winter on a flat car with great success, snow and sleet having stopped the road only twelve hours during the entire winter. Sleet stayed on wires and trees for ten days, the trolley wire being 3/4-inch in diameter, and in some places the ice being two inches thick on the rail. In seven hours the rail-scrapers cleaned up the entire road. It is possible to put 100 pounds tension on each of the scrapers. All parts of the car are adjusted and managed from the inside, so that only one man is required to

run it. With left hand on the controller, right on the brake, and foot on the lever, he controls everything. The scrapers require no attention, as they take all switches without attention from the operator. The gentleman standing at front of car is E. A. Gormon, cashier, the other is E. Kessler.

### THE PHILADELPHIA ELECTRICAL EQUIPMENT COMPANY.

In the November REVIEW was a notice that the Philadelphia Electrical Equipment Company had gone into business at 816, 818, 820 and 822 Cherry street, Philadelphia. The offices, warehouse and shops are all in one building, which is well equipped for the three branches of the business, construction, repairs and supplies. The active men in the company are Carl P. Young, general manager, and James R. Rettew, secretary and treasurer. They have



C. P. YOUNG.

gathered around them as assistants the best electrical and mechanical talent they could secure.

Carl P. Young has had a long experience in many different lines of electrical construction, and is an electrical and mechanical engineer. He says he has suffered agony in the past from the ignorance and mistakes of others, but hopes to never cause the same troubles and have his customers encounter the same obstacles at his hands, for every piece of work will be known to be perfect before it leaves the plant. Mr. Young served an apprenticeship for six years on marine engines and locomotives in Sweden, was engineer at sea for two years, worked at brass finishing for the Southern Pacific Railroad and was engaged with Crane Bros., Chicago, and the Edward P. Allis Company, Milwaukee. His electrical experience consists of work in the experimental room of Leo Daft, New York; Frank Sprague, New York; Gold & Stock Telegraph Company; James J. Wood, of the Ft. Wayne, who was then with the American Electric Company, making Wood's arc machines; and with the Julien Electric Traction Company on its storage battery experiments. In street railway work Mr. Young has also had a long service. For three years he was electrical and mechanical engineer for the Chatanooga, Tenn., Electric Railroad Company, and since that time he has been with the Hestonville, Mantua & Fairmount Passenger Railroad Company, Philadelphia, giving up his position for his present business. Mr. Young has charge of the electrical and mechanical work at the factory and the construction work out of town.

James R. Rettew, who has charge of the financial part of the business, though a young man, has had 17 years' experience in commercial life in Philadelphia.

Mrs. ANNIE HURLEY has sued the Brooklyn Heights Railroad Company for \$5,000 for killing a dog.

### SEVEN-INCH SHANGHAI T RAIL.

The accompanying engraving represents the new section of shanghai T rail which has just been designed by the Illinois Steel Company for street railway use. The shanghai T is now so well known among electric railways that little explanation is needed, save to say that the new section is seven inches high, which is an inch higher

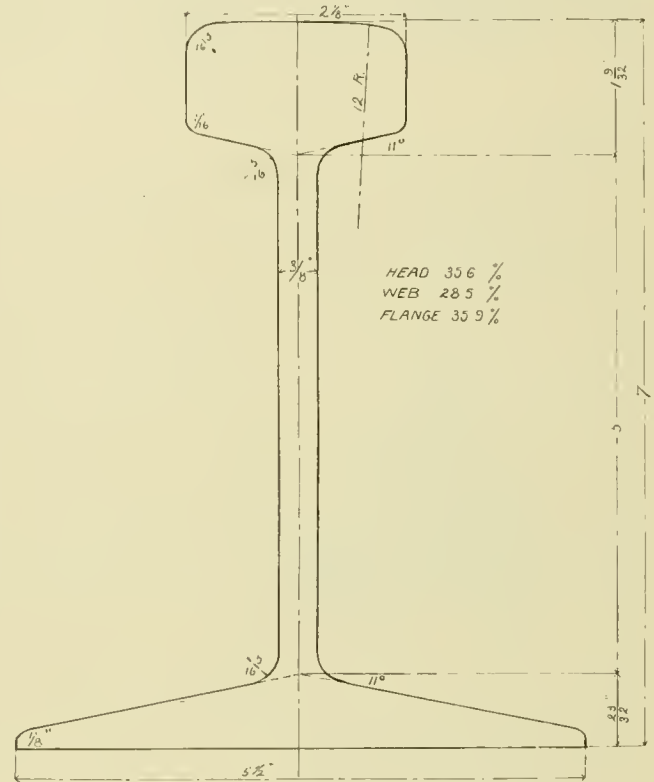

7-INCH SHANGHAI T RAIL.

than sections previously rolled. The weight is seventy pounds to the yard. Being seven inches high, it will accommodate any form of paving that a street railway may wish to use with it. While the 72-pound, 6-inch shanghai now in common use is high enough for the majority of places, there are some companies that wish to use very high paving blocks. This new section puts the T rail on an equality with the higher girder rails as far as convenience in paving is concerned.

### STRUCK BY LIGHTNING.

Our bright English contemporary, "Lightning," comments on the September REVIEW as follows:—

"The STREET RAILWAY REVIEW for September devotes some twenty-seven pages to an account of the city where the convention is to meet, its history, its buildings, and, above all, its street railways, power stations, etc. To those who can read the American tongue with facility, and who have time for technical literature on this scale, these pages will be inviting. Everything has been done that could be done in the way of print and illustration to make them attractive.

"In accordance with a custom almost universal in American journalism, this serious article is interspersed with short stories and rhymes, some humorous, some supposed to be so, and others mere news paragraphs."



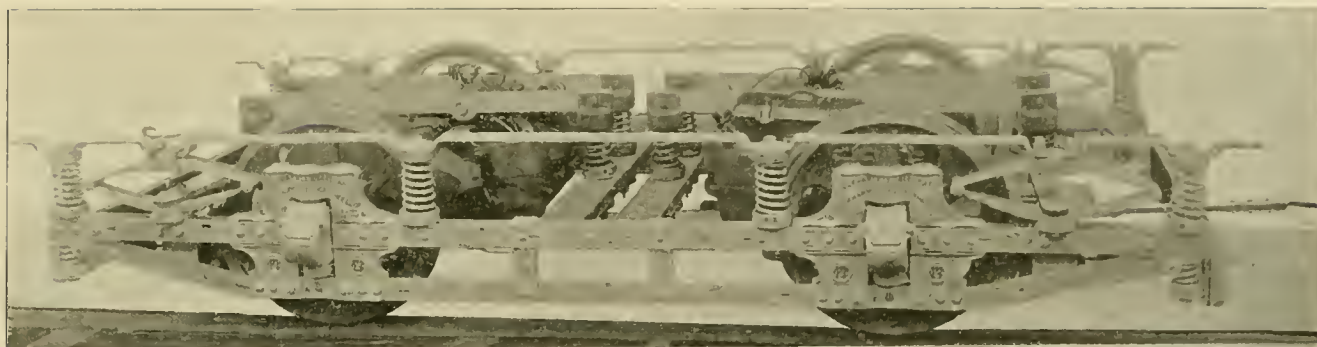

PECKHAM TRUCK EQUIPPED WITH WESTINGHOUSE MOTORS.

### SPRING SUSPENSION OF WESTINGHOUSE MOTORS.

The new No. 12 Westinghouse motors are so designed that nothing but spring suspension can be used. By this arrangement the motors are literally "hung up" from bars attached to the top of the motor case, and the greater part of the dead weight is taken off the car axle. Figure 1 shows the suspension on a Peckham truck as it originally appeared to the street railway public. A peculiar modification of this is used by the Terre Haute Electric Railway. Figure 2 is a rough outline giving a general idea of the Terre Haute method. Instead of having four bars (two to each motor) and suspending the motors from the middle of each pair of bars, there

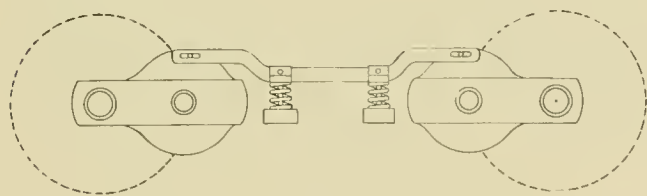

WESTINGHOUSE SUSPENSION—TERRE HAUTE.

are two bars and the motors are hung on each end. It is a very peculiar method, but seems to be giving excellent results in every day operation. The suspension bars were at first made straight, but they hit the beams of the car body, so that the body had to be raised on six inch sills. This made the steps high, and now the suspension bars used are bent down in the middle. The Westinghouse motors now being delivered to the Chicago City Railway have lugs or ears cast on the motor case which overhang the suspension bars and do away with the round pins or lugs which are seen extending through the suspension bars in Figure 1. This makes a much neater arrangement, as it allows the motor to be entirely closed and also lowers the suspension bars so that they do not come so near to the beams of the car body.

WHILE the franchise of the West Jersey Traction Company was before the city council of Camden, N. J., a crowd of men entered the council chamber wearing badges with the inscription, "Vote for the Traction Company. We need work."

### T RAILS PREVENT ACCIDENTS.

Robert E. Daniels, inventor of the Daniels' steel tie, has been giving his views to a newspaper man on track construction. He said, "Under conditions of rapid transit, why do we need girder rail? It is unnecessary for wagons to use railway tracks for wheeling. If a vehicle is in the tracks and endeavors to get out of the way of a rapidly approaching car, great care has to be used, for if there is not room to turn at the right angle a wheel is likely to come off, causing a delay to traffic. The time is past when street car lines should necessarily be compelled to put down such rails, not that the companies should have all the privileges and the vehicles none, but that the people should have the preference. With T rails the wagons can use the space between tracks, and when a car comes along can move out of the way without trouble, for if the pavement is correctly laid any wagon or buggy can cross and recross at will, as it is impossible to get tangled up with the rail, for there is only room for the flange of the car wheel between the pavement and the rail. The preventing of accidents will do away with all delays, thereby securing rapid transit. People who have had experience with rapid travel are never satisfied to go back to the old methods."

### IMPROVEMENTS AT SPRINGFIELD.

General Manager S. L. Nelson, of the Springfield Railway Company, Springfield, O., reports that the stockholders have voted to spend \$75,000 in improvements. The appropriation is apportioned as follows: Tracks, \$35,000 to \$40,000; power-house, additional power, \$10,000; cars, \$10,000; remainder extensions and general improvements. Work will be begun as soon as possible, so that the road and extensions will be ready for summer travel. Stockholders met December 15 to adopt a plan for raising the money.

A SATISFACTORY test has been made of some apparatus put in one of the cars running on the York road extension of the City & Suburban Company, Baltimore. President Perin said the apparatus was designed to heat all the cars beyond the city limits, but not those upon the the city end of the road.

### THE VALUE OF THE MAGNETIC BLOW-OUT.

The principle of the magnetic blow-out for preventing destructive arcing when electric circuits are broken, is used on all the cut-out and switching devices of the General Electric Company in places where live circuits are to be opened. It is this device that is the secret of the great success of the type K series-parallel controller. A test, showing its remarkable effect on fuses, was recently made in the station of the Brooklyn City Railroad. The regular General Electric generator fuse block was used.

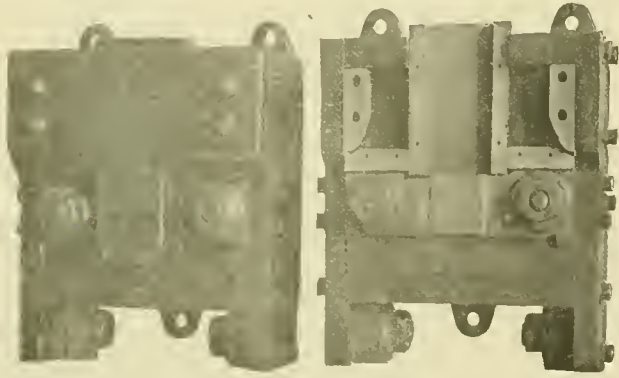

MAGNETIC BLOW-OUT—FIG. 1.

This block has the fuse strip placed between the poles of an electro magnet. It is shown in Figure 1, complete, and with the magnet removed. The test spoken of consisted of throwing a water resistance between the terminals of two 1,500 kilowatt generators, and increasing the current until the fuse melted. The fuse blew at 4,400 amperes and 500 volts. The result can be seen in Figure 2, which shows the fuse before and after melting. It is a beautiful illustration of the efficacy of a magnetic field in blowing out an arc. The magnetic blow-out is probably one of the most valuable of the General Electric Company's patents.

### LAKE STREET ELEVATED TO ELECTRIFY.

The management of the Lake Street Elevated Railway of Chicago has recently made public its intention to soon adopt electricity as a motive power. This has been expected for some time, and that electricity would soon be adopted seemed an assured fact when the control of this road was secured last summer by persons friendly to the Yerkes interests. As the Yerkes lines were at the time beginning on electrical construction work, and as the Northwestern elevated, a road projected by the same parties, is to be electric, it was but natural to suppose that the Lake street road would soon make the change. President D. H. Louderback says that trains will be operated by electricity next summer. Power will be obtained from the 11,000 horse-power station of the West Chicago Street Railroad at Western avenue and Washington boulevard, which is now in process of erection. This is about the middle of the line, and is only two blocks from Lake street.

### CHICAGO CITY RAILWAY MUTUAL AID SOCIETY.

The employes of the Chicago City Railway have recently formed a mutual aid society which is meeting with great success, as it now has 1,000 members out of the 2,500 persons employed by the company. Its object is to act as a mutual life insurance society. It is expected, however, before long to extend the field of usefulness, so as to help sick and disabled members. The present membership includes men in all departments, and the company officers are all on the roll. Each member pays up two 50-cent assessments when he joins, and in case of a death the heirs receive the amount of the second previous association assessment. This leaves a comfortable margin always in the treasury. The annual dues are 50 cents per year in addition to the assessments. The treasurer of the company shall, it is agreed, deduct from the salaries of members enough to make up the amount of the current assessment, and remit to the treasurer of the aid society. The company is not liable for the assessments so collected, as the treasurer is acting as an individual, and not as an officer of the company. Although the membership is not compulsory it is hoped by its officers that it can be made so soon, as it would then be on an absolutely solid basis. A medical examination is required of applicants. None of the officers receive a salary except the secretary and medical examiner. The officers are: George O. Nagle, president; H. M. Sills, vice-president; T. C. Penington, treasurer; F. P. Morehouse, secretary, and E. E. Babcock, medical examiner. Mr. Nagle will be glad to give any information about the organization to those who are contemplating similar associations.

### CAR BARN FIRE, PITTSBURG.

On the morning of November 3, a frame car barn of the Allegheny Traction Company, Pittsburg, Pa., was burned. In the building were twenty-seven horses and

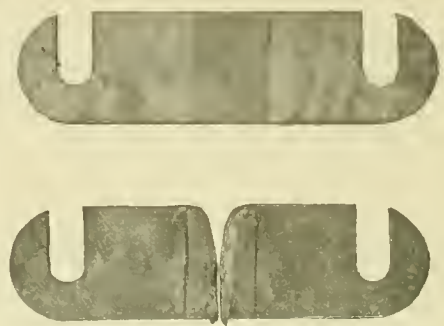

MAGNETIC BLOW-OUT—FIG. 2.

mules, thirteen horse cars, and twelve and one-half equipments of motors. The loss is about \$25,000, fully insured. The company will soon build an iron frame building, covered with corrugated iron, of about 180 feet by 70 feet, for a car shed.

AN ILLUMINATED CAR SIGN.

Superintendent T. M. Jenkins of the South Covington & Cincinnati Street Railway writes us that his company has for some time known of an almost general feeling on the part of the public for the necessity of an adequate route signal for cars, especially at night. A sign which is readable night or day, and which is changeable and inexpensive, best answers the requirements of the case. The one which is being used on the South Covington & Cincinnati cars is the invention of Bradford McGregor,

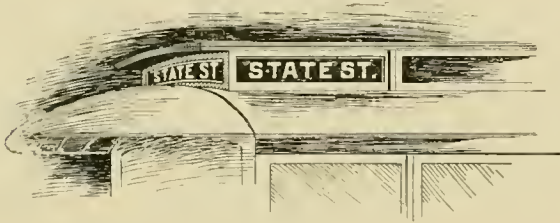

ILLUMINATED CAR SIGN.

a Covington man, and is proving very satisfactory. A dark stencil properly lettered is placed over translucent glass before the front and rear dome lights of the car or any other convenient place. In the day time the reflected rays of light give a white letter in a dark background. At night the light inside the dome gives the same effect except that the sign can be read from a greater distance. The important advantage of this plan over others, involving lettering in the car dome, is that the stencils can be easily changed when the car is put on a new route. It is also much more distinct than ordinary methods of lettering on the dome glass. The cost is merely nominal with the simple stencil fastenings used.

TO PRESERVE A BATTLEFIELD.

Recently the U. S. government secured a decision in a condemnation suit against the Gettysburg Electric Railway Company, awarding the latter \$30,000 compensation for a strip of land 6,000 feet long. The object of the government is to preserve the famous Gettysburg battlefield. While the railway company approves of this action from a sentimental standpoint, it has serious objection to giving up the strip, because this mile and a fifth is an integral part of the right of way of one of the branches of the road. The effect of the condemnation would be to cut the branch in two, destroy its contiguity, and prevent its further operation. An appeal has been taken.

Map of the United States.

A large handsome map of the United States, mounted and suitable for home use, is issued by the Burlington Route. Copies will be mailed to any address on receipt of 15 cents in postage by P. S. Eustis, Gen'l Pass. Agent, C., B. & Q. R. R., Chicago, Ill.

NEW TROLLEY GUIDE.

Something new in a trolley guide has been patented by William Dickerhoff and George W. Pollock, Cincinnati.

Two light brass prongs are placed on each side of any trolley wheel, which are held in position by two steel springs, each of 2 1/2 pounds tension. The object of the prongs is to hold the wheel to the wire, and when it jumps from its place to automatically guide it back again. When a cross-wire is reached the prongs are folded back automatically, being pressed under, so there is no interruption. When the cross-wire is passed the springs throw the prongs in place. The illustration shows the mechanism of the guide. The device has been praised by electric street railway men.

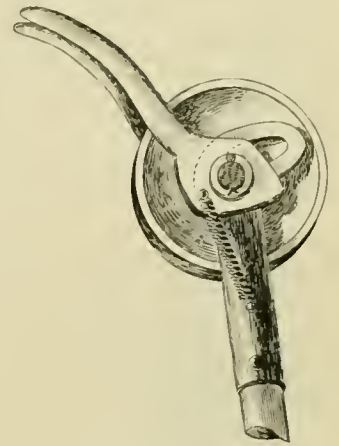

NEW TROLLEY GUIDE.

HOW THEY PLOW IN CITIES.

This illustration shows some of the difficulties of construction that have to be overcome by the street railway companies in the large cities. The view shows an actual

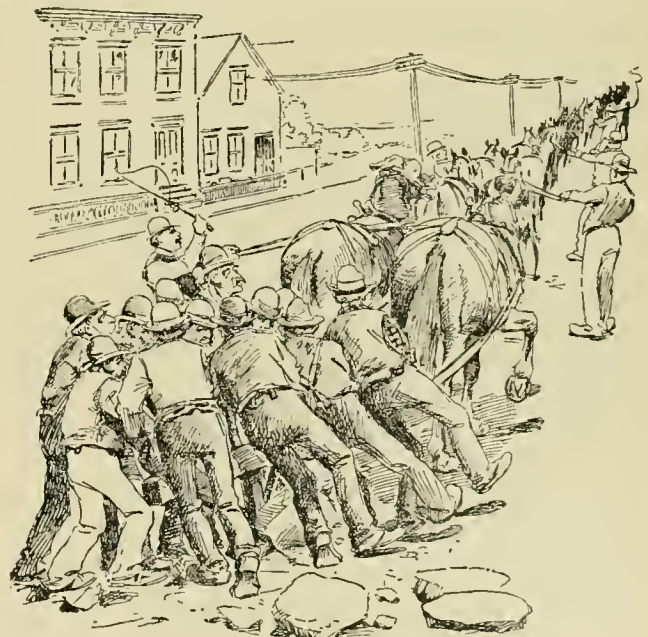

occurrence in San Francisco, where the Market Street Railroad Company was building a line on Devisadero street. The task was not an easy one, yet the road was completed in a very short time after it was begun.

THE Camden, (N. J.), Horse Railroad Company, has opened Wood Lynne Park as a pleasure resort.

## MODEMANN CAR FENDER.

The Modemann car fender was successfully tested on the Atlantic Avenue Railroad Company's line, Brooklyn, N. Y. A man stood in front of a trolley car, coming at a high rate of speed. The fender struck him above the right ankle, and carried him along without apparent inconvenience. A woman stood between the rails, when the car came along again, and was picked up as gracefully as an accomplished woman seats herself in a parlor. In neither case was the "victim" injured.

As will be seen from the illustration, the Modemann

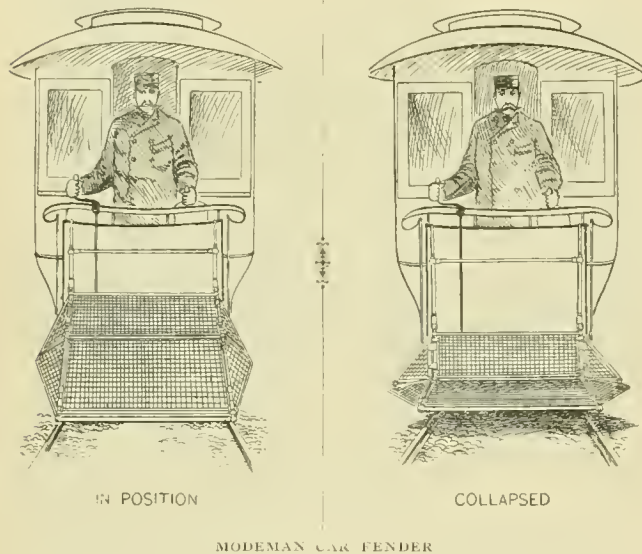

MODEMANN CAR FENDER

fender consists of half-inch mesh of flexible steel similar to that used for wire beds, which is fastened to the dash by means of iron tubing. The mesh, called an apron, has wings which hang down on each side of the car, and are extended 22 inches beyond the rails when an object 40 pounds or heavier is struck. At the bottom of the apron is a hard rubber roller, which does not touch the surface of the road unless the car rocks, and when a stone, or similar object is struck, the fender slides on the iron rods. When folded against the dashboard, the fender it is said, does not extend beyond the bumper. Only one fender is required for each car, as it can be transferred with little work, if desired.

## NEW SAN FRANCISCO MANAGER.

E. P. Vining is general manager of the Market Street Railroad Company, San Francisco, in place of M. D. Stein. This is the first appointment which has been made to this position since the consolidation of the road, Mr. Stein having held the position of acting manager of the transportation department, which office has been abolished. Though practically new to the street railway field, Mr. Vining is well and favorably known in traffic circles of steam roads, through his long connection with the Union Pacific Railroad, and later with the Western Trunk Line Association. The newspapers report his salary to be \$15,000 a year.

## THE LOST WAS FOUND.

A very crowded street car was going up Powell street, San Francisco, when it stopped to take aboard a stout, showily dressed woman. For a few minutes no one arose to offer her a seat, and as her fashionably tight attire prevented her reaching the steadying strap it was with difficulty that she kept her footing. Soon a young man, not over eighteen or twenty, arose and kindly offered her his place. She took it with the enquiring remark: "Well, you have found your manners, have you?" The quiet young man made no reply, but began searching on the floor of the car as if he had lost something. The lady asked: "Have you lost anything?" He replied that he had. She arose to allow him to search further, when he slipped into the vacated seat with the remark: "I've found it now and I mean to keep it." A very audible smile went around that crowded car, and the discomfited lady left it at the next crossing.

## NEW AUSTRALIAN CABLE LINE.

At Sydney, New South Wales, has recently been completed the Ocean Street Cable Line, which was begun in October, 1892. The line is two and one-half miles long, with many curves, and cost about \$777,600. The cables weigh 150 tons, requiring 250-horse-power to run them without cars. There are two horizontal compound surface-condensing Spencer-Inglis Corliss engines, built by Hudson Bros., Granville. The main shaft carries a twenty-five ton fly wheel, and a rope drum seven feet in diameter, with thirty-six grooves for 2-inch cotton ropes. There are three multipolar under-fire boilers of 250-horse-power each, and working at a pressure of 150 pounds to the square inch.

## THE PITTSBURG MCGUIRE FENDER.

Robert McGuire, Pittsburg, Pa., has patented a car fender, which consists really of a double fender. It is made of wire netting and has rollers at the end which comes over the tracks. The upper fender projects over

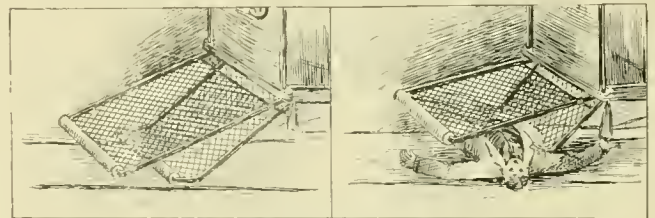

NEW DOUBLE FENDERS.

the lower one. The inventor says if the upper fender misses an object or rises above it, the lower one will be almost sure to catch it. The illustration shows the fender at rest and in action.

W. C. DIBRELL and R. W. Turner have petitioned for a receiver for the Nashville (Tenn.) Street Railway Company and the foreclosure of mortgages.

## FOREIGN FACTS.

BERLIN is to have an electric elevated railway. The vote of the municipality in its favor was almost unanimous.

THE Hull, Eng., tramways have been offered for sale by order of court at the upset price of \$75,000. The horse car system will probably be replaced by electric lines.

THE Committee of the Paris, France, municipal council, appointed to study foreign tramway systems, has returned after visiting Zurich, Vienna, Budapest, Milan and Geneva, and will soon present a report.

THE City Railway Company, Berlin, has a device for selling tickets during rush hours. It is a nickel-in-the-slot machine which rejects everything except coins of the right denominations. They might be of use on bob tail cars.

THE Buenos Ayres Tramway Corporation of Buenos Ayres, Argentine Republic, has declared a dividend for the half year ending June 30, of sixty cents per share upon full paid shares and forty-eight cents on other shares, amounting to over \$72,000. The car miles were 2,006,299, passengers, 13,200,719, and gross receipts, \$347,500 for the half year.

AN electric tram line is projected from the Furness district to Bowness, England, which is to derive its motive power from the falls at the southern end of lake Windermere, the finest water power in England. The available power aggregates 40,000 horse. It is to be distributed over a wide area, by electric currents of high voltage, for railways, light and power purposes.

BASEL, Switzerland, is soon to have an overhead trolley electric railway two miles in length. Double track will be laid for most of the distance. The line will include grades of five per cent. A three minute service will be maintained with twelve motor cars. The work of construction is to be carried on by Siemens & Halske, of Berlin, and R. Alioth, of Basel Moenchenstein, at the expense of the town.

RUBBER stud blocks are being tried on the footboards of some cars operated by the Glasgow & Southwestern Railway Company, of Scotland, to prevent the slipping of the feet when entering or leaving the cars. These blocks consist of inch-square iron plates having a covering of india-rubber on top and projecting nail points on the under side. A tap of the hammer fixes the block firmly in the wooden floor.

LONDON's tramways will all pass into the possession of the city government within four years, under the operation of the purchase clause in their franchise. This clause provides that the London county council may, at any time within six months of the expiration of a lease, purchase, take possession of and operate the railway. A portion

of the London Tramway Company's line has been bought, and another line in South London is purchasable.

AN electric trolley railway is now being constructed for the Dublin Southern District Tramway Company, from Dublin to Dalkey, Ireland, by the British Thomson-Houston Company. The route extends for eight miles through the beautiful scenery of Wicklow. Two 300-horse-power Babcock water tube boilers will be installed. The three engines of 150-horse-power each will be direct belted to the dynamos. The line is to be completed by the summer of 1895.

THE adverse report of the city engineer of Newcastle, Eng., to the Town Improvement Commission, upon the conduit electric tramway system at Budapest, has called forth a protest from Siemens Brothers & Company, in which they assert that the cost is not \$58,398 per mile of single track, as stated in the report, but \$19,466, and that the rails of the tramway do not rest upon loose brickwork, as alleged, but upon cast iron frames, to which they are firmly bolted, and which are set in the concrete conduit at the distance of four feet apart. The protest admitted that the width of the slot at Pest is one and one-fourth inches, but claims that there is no need for so great width, and that there will be no difficulty in contracting the slot to one-half inch. The objections as to interruptions of the service from climatic causes are explained away, there being no great difference between the climate at Pest and at Newcastle. The speed at Pest is given at eight miles per hour. Grades of 2 per cent at Pest are easily climbed.

THE Glasgow, Scotland, Tramways Committee has received a very favorable report from the deputation sent to Budapest to examine the conduit electric railways. The report states that the cars are run at a speed of eleven and one-half miles outside the town, nine miles inside, and four miles in narrow streets and at crossings. The total cost of constructing fifteen miles of single line, including power stations, car houses, rolling stock and general expenses has been \$926,000 or \$61,730 per mile. The receipts per car mile for 1893 were 22.5 cents, ranging from 16 cents to 31.6 cents, according to location of line. The traffic per car mile was  $8\frac{1}{4}$  persons, exclusive of season ticket holders. The operating expense per car mile, including cost of removing snow from track, repairs and maintenance of equipment, was 10.35 cents, of which 5.5 cents was expended for power and running of cars, including drivers. The margin of receipts over expenses is thus about 12 cents per car mile, to be applied on general charges and dividends to stockholders.

THE St. Louis & Southwestern Street Railway Company will build an electric line to various points in South St. Louis and to Forest Park. The officers are George C. Fox, president; A. E. Weiss, secretary; J. M. Wiener, treasurer.

## BRICK, GRANITE AND CEDAR PAVEMENT.

An interesting object lesson is presented by the illustration shown in this connection, which is a section of La Salle street near the corner of Washington street, giving two cable tracks operated by the North and West Chicago Street Railroad Companies. The pavement nearest the observer is end-cut brick  $7\frac{3}{4}$  by  $3\frac{3}{4}$  by  $2\frac{3}{8}$  inches; between the rails is granite block, and between



SHOWS ADVANTAGES OF BRICK PAVEMENT.

the tracks is cedar block. The brick pavement shows for itself its superior merit, as compared with the other two varieties so far as the laying and surface is considered, but its other advantages, such as cheapness, durability and ease on horses have been demonstrated in other ways. The section of brick shown was laid in August, 1894, by the Purington Brick Company, Galesburg, Ill., and the photograph was taken October, 22. Had the brick been of larger size, there would have been less chipping of corners and less breakage across, under the heavy traffic. In both cases the percentage is small, and it is noticeable that having reached a certain stage, the breakage becomes no worse.

W. M. Jeffrys has been appointed electrician of the Warren, N. Y., Street Railway Company, in place of J. A. Seamons.

THE Ann Arbor & Ypsilanti Street Railway Company, Ann Arbor, Mich., carried 80,000 passengers last year, and its receipts paid all operating expenses, including maintenance of track and rolling stock. For eight months there was no connection at the Ann Arbor end. The express business is increasing. The old officers were re-elected: J. E. Beal, president; H. P. Glover, vice-president; J. T. Jacobs, secretary; D. L. Quirk, treasurer.

## A SHORT CIRCUIT AND RUNAWAY CAR AT WALTHAM, MASS.

One of the most peculiar electric railway accidents it has ever been our lot to chronicle, occurred last month at Waltham, Mass., on the Newtonville & Watertown Street Railway. The car was standing near a steam railroad crossing waiting for a freight train to pass, when a short circuit occurred in the car wiring. The car floor took fire and the car started ahead rapidly, breaking through the crossing gate and running on the track just in time so that the front end was struck by the locomotive. There were no fatal injuries. There was a storm at the time, which fact accounts for the short circuit. It was a most unusual accident, and one not likely to occur in a long time in the operation of all the electric cars of the country, but it brings forcibly to mind the point editorially commented on by us last month in regard to the necessity of better car wiring. The car to which the accident happened was probably wired as well as the majority of cars running in this country to-day. The accident was not so much a reflection on the way that particular car was wired, as it was a strong criticism on common practice in car wiring. As stated last month, there are four or five cases a month of cars taking fire from wires, as reported in the newspapers, and there are probably as many again that are not so reported. It is not an

easy matter to wire a car so that the moisture from hard rain and snow storms will not affect it, but there is room for improvement on many present methods.

## ELECTRIC LIGHT ON THE BROOKLYN BRIDGE CABLE ROAD

Bids were recently received by the trustees of the Brooklyn bridge cable line for the installation and equipment of a system of gas or electric light to supplant the oil lamp. The Safety Car Heating & Lighting Company submitted a bid to equip 60 cars and install the necessary gas plant at a price which would make the cost of lighting 4.4 cents per hour per car. The General Electric Company made a bid which would make the cost 5.3 cents per hour per car. The Electrical & Mechanical Engineering & Trading Company bid a somewhat higher figure than the General Electric Company for the equipment but guaranteed that the cost would not be over 2.78 cents per hour per car, and was awarded the contract.

THE Highland & Dravosburg Electric Railway Company, which is constructing a line between Pittsburg and McKeesport, has leased the system of the McKeesport & Reynoldston Company. The trip between the two cities will be made in 35 minutes, over a double track line, the fare being 30 cents round trip.

## RESULT OF CHEAP RIDING.

Street Railway men all over the country have been interested in the fight that has been going on between the two street railway companies of Savannah, Georgia, which have been selling tickets for a cent each, and on some lines round trip tickets limited to one day, for 1 cent, or one-half a cent a ride. Both roads seemed to agree, however, that a basket of washing was worth 5 cents for a ride, so there was no cutting of fares in that respect. Such a bitter warfare as has been waged was certainly expected to outgrow its weapons, and the next move has been awaited with interest.

The courts have been appealed to, but not in the usual way. J. S. Collins, president of the Electric Street Railway Company, writes: "About six months ago our rival railway company started a rate war for the purpose forcing us to buy it out at its own price, and finding that the cut in fares did not result as had been hoped, J. H. Harriman, representing the owner of the company began selling our bonds short, and after having sold a large amount for August delivery, found that he could not get the bonds. He then set to work to try to get the creditors of our company to apply for a receiver. After several weeks he secured three creditors to make application to the court. The case came up for trial and was dismissed, the judge saying it was his duty to protect, not to wreck property. The evidence showed that our rival and one other party, who held a disputed claim against our company, had entered into a conspiracy to wreck our property, and we now sue these people for damages to credit, etc. The suit is for \$25,000 damages, in attachment against the Sloss Iron & Steel Company and J. N. Harriman."

James H. Johnston, president of the City & Suburban Railway, says the only way his company's name has been associated with the suit is that an attachment was laid against Mr. Harriman's stock in the company. This is the only expression from the City & Suburban Railway. Mr. Harriman says he doesn't think the suit will amount to much, and that the electric railway people are trying to amuse themselves.

In regard to the reduction of fares Mr. Harriman is reported to have said:

"The City & Suburban in this fight is simply taking care of itself, and doing what anybody else would do under the same circumstance. We did not begin the fight, and we do not propose, now we are in it, to let it drop. The electric railway people commenced this game of cutting rates sometime last spring, or the latter part of the winter, and we have simply met them by the same or further reductions, which we propose to keep up. The rate cutting was begun by them and we followed. If they do not like it, they have nobody to thank but themselves. I am glad at any rate that the public in Savannah is getting the benefit. The City and Suburban is more of a home institution than the other crowd, anyhow. The entire issue of the City & Suburban bonds is owned here in Savannah by citizens and charitable

institutions. But a large proportion of the bonds of our opponents is owned in Nashville and other places at a distance. Our lines were laid down first, and we are the best located for the convenience of the public. The Electric railway people in many instances came along and paralleled our lines, and then commenced the rate cutting as I have already stated.

"We did not want war and were ready from the start to agree with the Electric railway people. We did agree with them last November. An agreement was entered into in writing, signed by Mr. Parsons and myself, representing the City & Suburban's interests, and by Mr. Wrenne and Mr. Collins representing the Electric railway interest. It was a fair and liberal agreement and settlement of all differences. When Mr. Collins and Mr. Wrenne got back to Savannah they reported that their board of directors had repudiated it. We were surprised, because Mr. Collins and Mr. Wrenne had represented themselves to us as being authorized to act."

## WHO PAID THE FARE?

The little by-play between two women in the street car to see who shall (not) pay the fares, while both are begging to be allowed to do it, is always interesting, although it has been noticed ever since horse railroads were discovered. A conductor on a Broad street trolley car says that he actually saw an exception to the usual proceeding last week. Two girls got on at Taylor street and both opened their purses and began pretending to look for dimes in the ruck of cents, quarters, buttons and scraps of paper.

"Let me pay it, Anna. I know I have a 10-cent piece right here," said the young woman nearest the door.

"No, let me this time, Emily. You know you paid last time we went down town together, and I am sure I have just got the change."

They seemed to have difficulty in fishing out the money, and meanwhile the conductor entered the car and stood in front of them. Both got out their dimes at the same instant, and they looked into each other's eyes.

"I'll tell you what I'll do," said Anna. "Let's match to see who pays? You match me," and she laid the dime on the back of one of her gloved hands and covered it with the other.

"No, I'll match you," said Emily, thinking she was changing the order of arrangement most shrewdly, and consequently there must be some advantages in so doing.

Both coins came out head and Emily remarked with a sigh, "There, you have lost, and I'll have to pay," and taking up the two coins she gave one to the conductor and put the other in her purse.

The conductor said it was all right in the end, but he could not understand the mental process by which the conclusion was arrived at. As she was leaving he heard Emily say, "Oh, isn't it exciting. We'll have to do that every time, but let's do it before we get on the car."

## CENTER POLES ON RESIDENCE STREETS.

When a trolley road first tries to get a franchise along the residence streets of a district where property owners are not acquainted with the system, there is frequently a general uplifting of hands in horror at the thought. People who do not come in daily contact with electric railways have little idea of what they really are, and their opinions are formed very largely by the newspapers. It is a notable fact that all the objection to the trolley system in any place comes before it is installed. After it is once put in there is not one man in a thousand that would vote for going back to horse cars. One of the most difficult things is to assure a property owner that a neat center pole line will not disfigure his street. The best way to convince such people would of course be to take them to some of the beautiful residence streets of some of our principal cities and let them see for themselves that a center pole line is more of an ornament than a disfigurement to a street. As this is not practicable, the next best thing is to show them some street scenes which will give them an idea of how the center pole system looks. The Chicago City Railway has used this plan to advantage. The accompanying page of engravings is from photographs taken along Indiana avenue, Chicago, on which the Chicago City Railway now operates a horse line. On one set of engravings the street is shown as it

actually is at present, and in the corresponding ones in the other set the center pole line and trolley line has been drawn in to represent the street exactly as it would appear equipped with the trolley. The comparison is certainly not unfavorable to the trolley. The ornamental poles set regularly give a symmetrical appearance to the street and make a very pleasing effect. This, with the fact that there will be no more horse cars dragging their weary way down the thoroughfare, ought to be a sufficient argument to any of the property holders, to say nothing of the benefits of rapid transit to the city. The other engraving is from a street in Evansville, Ind., where the Electric Railway Equipment Company of Cincinnati recently did some neat center pole construction work. These poles originally had ornamental bases, but the city council thought they were an obstruction, so that the bases were cut off.

D. J. HAUSS secured a verdict for \$500 against the Maysville Electric Railway Company in the U. S. Circuit court, Covington. He sued for \$2,500 for extra work done as a sub-contractor.

## NEWSBOYS ON STREET CARS.

In all large cities the abating of the newsboy nuisance has caused more thought and worry than many an important question involving the operation of the vast systems of street railways. These obstreperous, omnipresent, dirty little youngsters, are continually jumping on and off cars, endangering their own lives and annoying passengers and conductors. Many ways have been tried to keep them off. Some cities have ordinances directed against them, and in other places the conductors have instructions to keep them off. The little rascals, however, shrewdly watch their chances, jumping on the cars at a point remote from the employes.

Quite a number of serious accidents have resulted from this apparently irrepressible habit. The West End Street Railway Company, Boston, has tried many plans, none of which has worked as well as was desired. Now the

company has a contract with the Hotel and Railroad News Company, by which newsboys wearing its badges are the only ones allowed on the cars. The limit of age in this contract provides that no boy less than eighteen years old shall be employed, the object being to have only large, well grown boys employed, who can look after themselves. C. S. Sergeant, general manager of the company, writes: "While this does not rid us of the newsboy nuisance, it has proved more satisfac-

tory than any other method which we have tried."

The Southern News Company has made a proposition to the Orleans Traction Company, New Orleans, for placing a uniformed newsboy on the rear platform. Those who sell morning papers, to be on the cars from 4 to 11 a. m., while those selling afternoon papers are to ply their trade from 2 until 7 p. m. The boys are not to be permitted to jump on and off cars in motion. Occasionally they will walk through the cars for the accommodation of passengers, being instructed to be polite and courteous, and to keep out of the way of the conductor, so they will not interfere with him in the discharge of his duties.

If the larger companies make arrangements with news companies on similar lines, they will always have some one on hand to repel the common newsboy from the car, for it will be part of the duty of the uniformed lad to see that no one encroaches on his preserves. It will also relieve passengers from the annoyance of boys coming through the car at every street crossing, shouting their wares into sensitive, tired, and unresponsive ears, and in the winter time creating death dealing drafts by the opening and shutting of doors, when the car is in motion.



CENTER POLES—EVANSVILLE, IND.



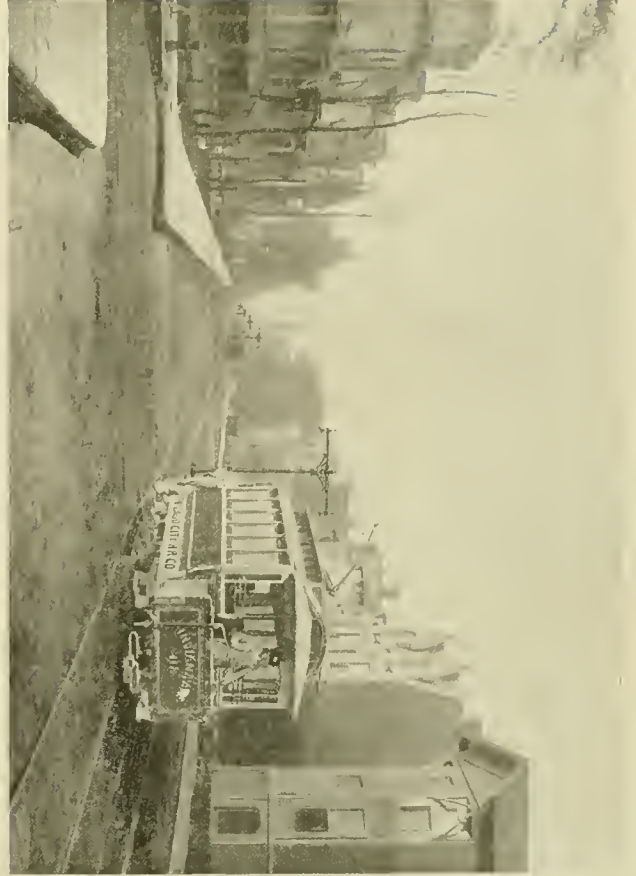

CENTER POLE CONSTRUCTION IN RESIDENCE STREETS—SHOWING SAME STREETS WITH AND WITHOUT POLES.



Interesting Bits of Information from all Parts of the Country,  
Boiled Down for Busy Readers.

WORK has been begun on the Sutro line, San Francisco.

IN Syracuse it is called the "punch your face" transfer.

BUFFALO has no horse car lines. Electricity is now used on all the lines.

THE new Niagara Falls, Whirlpool & Northern Street Railway Company is in operation.

THE trolley mail cars, of Brooklyn, now run into the postoffice yard over a special track.

STANDARD gage will be adopted by the Market Street Railway Company, San Francisco.

THE York City Railway Company, York, Pa., carried 80,000 passengers during five days of the fair.

THE Akron, O., Street Railway Company has been giving a prize to the conductor selling the most tickets.

LARGE railroad crossing signs have been placed at crossings by the Redlands, Cal., Street Railway Company.

A KNIGHTS OF LABOR assembly, composed wholly of street railway employes, is being organized at Pittsburg, Penn.

THE Cumberland Valley Traction Company, Harrisburg, Pa., has completed its new road in Cumberland County.

THE 21 street railways of St. Louis made 1,487,441 trips and carried 24,745,396 passengers the third quarter of the year.

THE new line of the Millvale, Etna & Sharpsburg Company, Pittsburg, is completed, and opens up a large territory.

J. M. MOORE, has finished tracklaying for the Piedmont Construction & Improvement Company, Charlottesville, Va.

THE tilting of a manhole in the middle of the track, wrecked a car of the Missouri Street Railway Company, St. Louis.

THE Homestead & Highland Street Railway Company, of Homestead, Pa., will soon have its new road completed.

THE People's and Electric Traction Companies, Philadelphia, have decided to exchange transfers between the two systems.

THE Dallas & Oak Cliff Street Railway Company, of Dallas, Tex., has completed the equipment of its road for electric service.

THE contract for the Manchester & Winchester, O., Electric Railroad Company has been awarded to Chicago parties for \$200,000.

ERBECK BROS., are building the Homestead & Highland street railway, which will connect with the Duquesne traction system, Pittsburg.

THE Watertown, N. Y. Street Railway Company, has done away with conductors. Three men meet cars at certain points and collect fares.

THE Brockton, Mass., Street Railway Company carried 184,752 passengers during fair week, as against 170,052 during the fair week of 1893.

THE Philadelphia Times notes the need of a phrase as applied to electric cars that will answer the same purpose as the old expression "one-horse."

JAMES ROBINSON, superintendent of the Third Avenue Railroad, of New York, is the designer of a wheel guard fender, that is doing good work on that line.

THE West End Street Railway of Boston has begun the operation of putting its feed wires underground; \$360,000 worth of work is to be done at once.

SANFORD & BROOKS, Baltimore, Md., bid \$175,000 and secured the contract for building the Dravostburg & Glenwood Electric Railroad Company's line.

JOHN MAHAN, superintendent of repairs of the board of education of Newark, N. J., was injured by a trolley car, and had the manliness to say that it was his own fault.

J. W. HARTSELL, who built the first street railway in Topeka, Kans., has failed in San Francisco, having lost \$300,000 in an irrigation scheme and \$50,000 in other ventures.

THE recent opening of the new electric line by the Allegheny Traction Company has abolished the last horse power lines on the down town streets of Pittsburg and Allegheny, Pa.

ONLY two killed and eight injured is the casualty record of the Citizens' Traction Company, of Pittsburg, Pa., for the past two years, although 28,000,000 persons have been carried.

THE annual report of the Electric Traction Company, Philadelphia, shows 41,040,346 passengers carried; receipts, \$1,916,936.77; expenditures, \$1,823,562.82; balance, \$84,363.95.

THE Shamokin & Mount Carmel Electric Railway Company, of Shamokin, Pa., is selling miners' tickets at

the rate of thirty for one dollar, but these are good only on cars bearing the sign, "Miners' Car."

THE conduit electric system will actually be given a trial in New York by the Metropolitan Crosstown Railway Company, of which H. H. Vreeland, is president. The work of construction has already begun.

THE bondholders of the Piedmont Consolidated Cable Company, Oakland, Cal., petitioned the court to postpone the sale, as the receiver is making alterations and improvements that will greatly increase its value.

ONE of the ex-motormen got judgment against the Oakland, San Leandro & Haywards Electric Railway Company for \$25, the amount of his deposit, which had been retained on account of damages in a collision.

AT a recent annual meeting of the Moline, Ill., Central Street Railway Company the following directors were elected: S. H. Velie, W. L. Velie, L. S. McCabe, W. E. Reck, E. H. Guyer, J. R. Kimball and J. B. Cornwall.

THE Metropolitan Traction Company, New York, statement shows that it is earning 5 per cent. on \$27,301,650. When the Lexington and Columbus avenue surface lines are completed the company will own 143 miles of surface road.

A commodious waiting room has been opened at an important transfer station by the City Railway Company, of Louisville, Ky. The room is steam-heated and contains a lunch counter, coffee stand and other conveniences.

THE Cumberland Valley Traction Company has finished a new electric railway across the Susquehanna river at Harrisburg, Pa., permitting cars of the East Harrisburg Passenger Railway Company to run over into Cumberland County.

THE city of Detroit, not only was badly whipped in its alleged case against the Citizens' Railway, but is now confronted with an attorney's fee of \$40,000, for all of which the deluded public can thank that officious and misguided Mayor Pingree.

SOME Baltimore clergymen set aside a Sunday to ranting on the car fender question, most of them showing a lamentable ignorance of current events in their own city. If doing were as easy as talking, what a change there would be in this world,—and in car fenders.

WHEN the people celebrated the opening of the Pawtuxet Valley Electric Railway, they borrowed a cannon. So great was the enthusiasm, that the cannon burst. Demand was made for cannon or money by the owner of the engine of war, and a popular subscription was taken.

QUICK work was done in laying the Eleventh street track of the Oakland, Alameda & Piedmont Electric Company from Washington street to Broadway. The macadam was taken up, dirt removed, the rails laid, and the street placed in first-class condition in ten hours one Sunday.

THE management of the St. Thomas, Ont., Street Railroad Company has been changed by the election of D. N. Cameron as president and John Break as secretary and treasurer, in place of Cameron Currie and Strathearn Hendrie, who resigned. The new management contemplates a change in motive power from horses to electricity.

THE annual statement of the receiver of Helena, (Mont.), Rapid Transit Company, shows a paid in capital of \$500,000; debts, \$24,684.45, of which \$21,431.45 is due the Minneapolis Trust Company; \$1,777.27 for wages, and \$1,475.75 for supplies; outstanding claims not counted as debts, \$5,908.81; \$3,743 due on notes and a mortgage for \$24,000.

DURING the six days from September 26 to September 28 there was a fair in Ottawa, Can. The Ottawa Electric Railway Company took in \$1,001, the first day; \$860, the second; \$1,625, the third; \$2,007, the fourth; \$2,114, the fifth; \$1,314, the sixth; total, \$8,921, an average of \$1,486 a day. The road earned \$85,000 since June, an average of \$816 per working day.

SMOKING cars have been put on the lines of the People's Traction Company, Philadelphia, for use during the rush hours. In other cities where the plan has been tried, it has been abandoned, because it has been impossible to keep the women out, as they seemed to prefer riding in the smoker and complaining to the conductor that the "horrid men smoke all the time," rather than go in the car provided for them.

AT the annual meeting of the stockholders of the Pittsburg Traction Company, the annual report for the fiscal year, ending July 1, was read. Receipts from all sources, except inclines, were \$297,407.06; from inclines, \$60,401.67; total receipts, \$357,989.63; expenses and taxes, \$183,420.35; incline expenses, \$75,653.43; less dividend received from Mt. Olive incline, \$3,714; total expenses, \$365,800.78; loss for year, \$7,820.15.

SMOKING is not permitted on cars of the Rochester, N. Y., Railway Company, and recently when a prominent attorney boarded a car he was requested by the conductor to stop smoking or leave the car. Thereupon the passenger committed a vicious assault upon the conductor, blacking his eye and injuring his jaw. The company will now bring suit against the pugnacious attorney as a warning to others who disregard rules and threaten the conductors.

## JAPANESE RACK RAILWAY.

Anything about Japan is of interest to the general reader on account of the war between that country and China. On April 1, 1893, was opened for business the Usui Toge Rack Railway, which fills up a seven-mile gap in the main line connecting Tokio with Naoyetsu, a seaport town. Work was begun in August, 1891, many difficult engineering problems having to be solved and overcome. There are 26 tunnels and 18 viaducts, the largest of the latter being the bridge shown in the illustration, which consists of four spans of 60-foot arches, and in its highest point, being 106 feet from the river

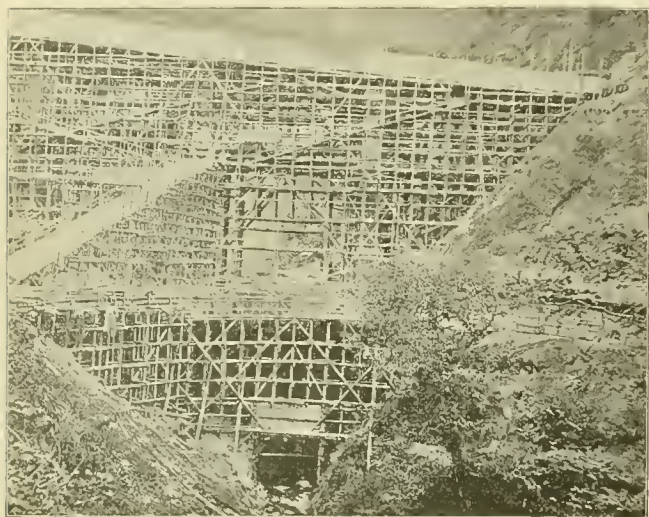

BAMBOO SCAFFOLDING FOR VIADUCT.

bed to the formation level. There were 2,300,000 bricks used in the bridge, which cost 300 yen, or about \$300 a running foot, the total span being 267 feet between abutments.

Fig 1 shows a profile of the road. Besides the tunnels, viaducts and culverts shown in these views, there were 438,000 cubic yards of cutting and 173,400 cubic yards of embankments. The tunnels cost about 65 yen, or about \$65 a running foot. Rack rails with cross steel sleepers were used, rails of special lengths having been required for the outside and inside of each curve, the sleepers at curves having been placed radially. Except on inclines ordinary T rails were used on wooden

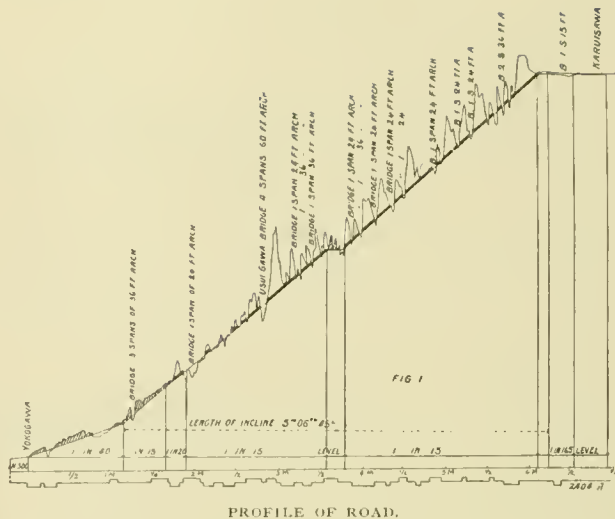

cross ties. The general finish of the curves is said to be excellent, the rails being laid in a true curve, giving smooth running to the wheels of the rolling stock. Mr. Hongma and Messrs. Kikkawa and Watanate were the engineers in charge. Figs. 2 to 4 show the methods of laying rails. For the description and views we are indebted to the courtesy of Engineering of London.

### DIDN'T WEAR HOOPS.

He was a near-sighted German who entered a crowded car, and sat down in the lap of a colored man, who gave him such a push that he landed in the lap of an Irish woman across the car. There was an amusing dialectic war of words. When all was silence, the German turned to the colored man and said: "Vell, vat vas der madder mit you? Does you veer hoops?" After a while the colored man got out, so the German prepared to take the vacant seat. He was so slow about it, however, that a young lady slipped in ahead of him, and he landed in her lap. She gave a scream and a push, and as he was hanging on the strap, the German remarked, "Vell, vat vas der madder mit you? Does you veer hoops?"

J. C. Hutchins has been elected vice president and assistant treasurer of the Citizens Street Railway Company, Detroit, in place of Major J. V. Johnston.

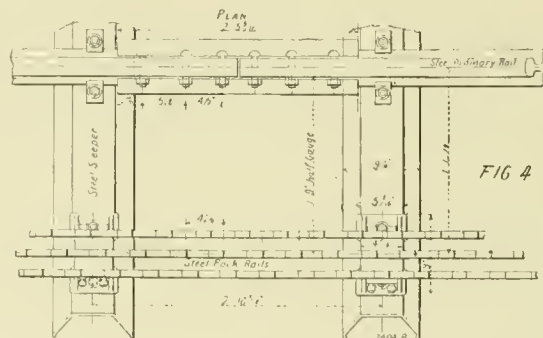
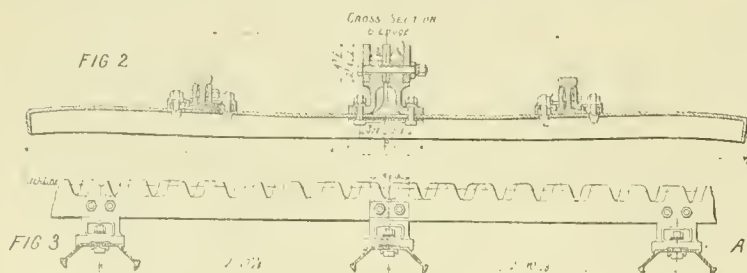

FIGS. 2, 3 AND 4.—SHOWING METHODS OF LAYING RAILS.

**NOVEL METHOD OF CREATING TRAVEL.**

The REVIEW is always pleased to learn of new methods of creating travel, and never loses an opportunity to give its readers the benefit of any suggestion it may discover along this line. That more managers do not give attention to the possibilities of creating good business out of practically nothing is by no means to their credit. The smaller roads are the ones which usually can work such enterprises to best advantage, and are also the very ones which most need the business.

W. W. Bean, president of the St. Joe-Benton Harbor, Mich., road, has a line leading three and a half miles out to a pretty park, which while all right as a park was not calculated to attract a great rush of people to see green grass and trees which flourish right in town, so he bethought himself early last spring of supplying attractions which would draw. The first available feature was a traveling medicine company which was giving free performances. The park was put at their disposal, and a miscellaneous assortment of groceries purchased, sacks of flour, boxes of soap, packages of oatmeal, hams, candy, stew pans, and enough other domestic miscellany to fairly stock a small store. These were turned over to the medicine company. The next step was to freely advertise the scheme, in which announcement was made that a ten cent round trip ticket would be sold on a certain date, good only that day, and which included also admission to the park and one guess on the presents. People who preferred to walk out or go in any other than the approved street car method paid ten cents to get inside the grounds, and had no guess either. The ticket used for this scheme is shown herewith, and is in coupon form.

Coupon . . . **Guess Ticket**

Useful Presents Given Away  
By Scotch Medicine Co.

Write Name

St. Joe and B. H. Electric Ry. Co.  
Good only Sunday May 27-'94  
Between 1 p. m. and 6 p. m.

**From Pavilion**

Admit Bearer . . .  
to Pavilion

**Sunday, May 27, '94**

St. Joe and B. H. Electric Ry. Co.  
Good only Sunday, May 27, '94  
Between 1 p. m. and 6 p. m.

**To Pavilion**

Each passenger wrote his or her name in the guess coupon, and when all were in they were shuffled in a big box, and then a medicine man would set up a sack of flour, and blindfolded, draw out one of the guess coupons,

the prize going to the person named on the coupon. In this way a great deal of sport was had, among the big crowd which was thus attracted. When the grocery scheme had been worked for all it would stand, a variety of entertainments was given, including free band concerts, a cake walk, picnics, comedy companies, and a big dance every Saturday night. The attendance kept up all summer, and was only checked when cold weather no longer made outdoor entertainments possible.

There are many other roads which can now lay their plans for next summer's business, and which can easily study up other schemes to suit the special requirements of each individual community.

**USE OF HORSES ON AN ELECTRIC GRADE CROSSING.**

At one of the very bad steam railroad crossings on the West End street railway system of Boston a very sensible precaution is taken to prevent the possibility of a car getting stalled on the crossing. The crossing is at a very obtuse angle, and, as all railway men know, is for that reason a very dangerous one, because of the time that it takes to get a car across. Fast trains are also very frequent on the steam road. The precaution is to have a team of horses, which is hitched to each car as it goes over the crossing. In case the fuse blows or the trolley comes off the car is not stopped. It is a rather expensive safeguard, and it would probably not be warranted except at such exceptionally dangerous crossings. The Chicago City Railway and some other roads use a fork extending on each side of the trolley wheel, so that in case the trolley wheel comes off the circuit is not broken. This reduces the danger of stoppage by a very large per cent, as the only other thing that would be likely to occur to the motive power is the blowing of a fuse. While the blowing of a fuse is a possibility it is not a common accident in such places, as the track at a crossing is necessarily nearly level and there is not a large demand for current. Consequently the danger from this source is very small, although when a fuse does blow it is a matter of several minutes to replace it. Experience has shown that the majority of grade-crossing accidents to street cars are the result of carelessness on the part of the conductor and gateman, or inability to see trains on account of fog and smoke. For such there is absolutely no preventative except more care on the part of conductors. It makes little difference whether the car has any motive power or not at such times. If anything, electric motors without any horses are the best at such times, because there is a possibility of turning on enough current to get out of the way. After all, as was said before, the best preventative for these accidents is care in ascertaining that there is no train approaching that will be on the crossing until the electric car can get across, even should there be an accident to its motive power. There should be a rigid discipline maintained among conductors and motormen in regard to this.

## WHAT STREET RAILWAYS CAN LEARN FROM STEAM RAILROADS.

1.

Many are the lessons that street railways have yet to learn from steam roads. Even former steam railroad men who join the street railway ranks seem to forget some things that their previous experience has taught them. The system of terminal switching put in operation on the Chicago City Railway cable lines recently, is

to D, stops, hitches on with a rope to the trailer or trailers at E and pulls them over to its own track by means of the cross over which is made for trailers only and is not provided with a slot. Before the grip car has stopped, but while both grip and trailer are running by momentum, the grip car is slackened in speed enough to loosen the rope which is unhitched from the trailer and dropped. As the grip is still moving the rope is stretched out straight alongside the track so that it can not be tangled or run over. When the next train comes along

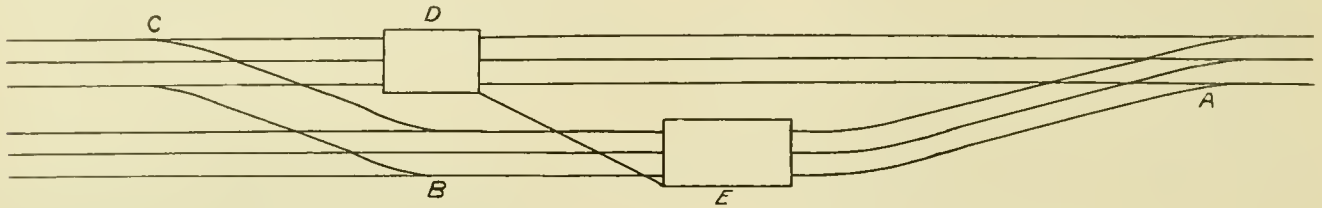

FIGURE 1—SWITCHES AT SEVENTY-FIRST STREET AND COTTAGE GROVE AVENUE, CHICAGO.

simply a method used for many years on steam roads. Figure 1 is the plan of the switches at the terminus of the Cottage Grove avenue cable line at Seventy-first street, which is the last one installed. The operation is as follows:

A train arrives at E and the grip car is uncoupled. The grip car is then run across to a point beyond the run off at A. Its momentum is sufficient to carry it over the switch after it has dropped the cable on one track, and when it has passed the run off A on the other rack it can again pick up the cable. It then runs back

the conductor drops off, picks up the rope and gets it ready to hitch across between the cars while the grip car is switching. On this road the saving is great as the switching was formerly done by horses. It also has some very marked advantages over common methods on electric roads.

An old steam road, man who is now superintendent of an electric road, was shown the plan recently and felt like kicking himself over several counties for not having used it before in switching trailers on his road. He had been using the method for twenty years on steam roads but

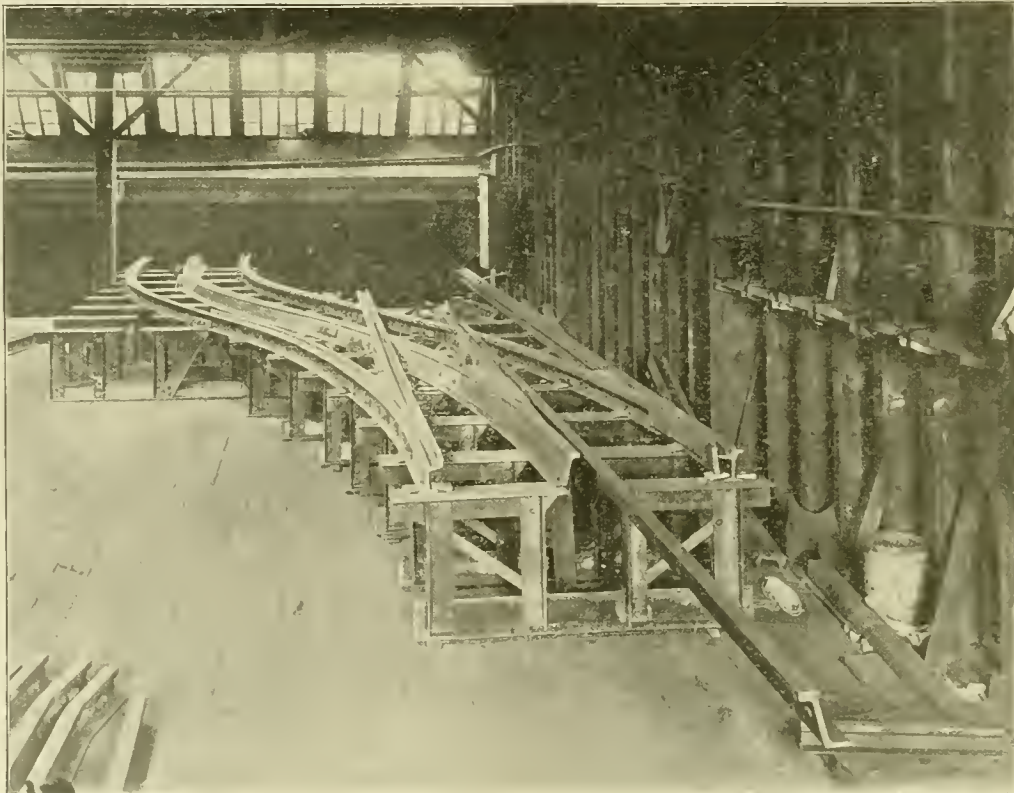

GRIP SWITCH.

had fallen into the old street railroad rut when he took charge of an electric road. Not only does the method save time but it saves a great deal of wear and tear on switches, men and overhead work. By the common method of backing up the motor car to hitch to a trailer the trolley has to be turned three times where once suffices with the plan under discussion. Then again, three overhead switches are necessary with the common method and only one with this. In fact that single overhead switch is not a necessity, as the motor car is alone and will run through by momentum. The fact that the rope method eliminates the running over with current on of

weight on it while it is being thrown and consequently there is little wear.

For an electric road the most advantageous arrangement would probably be to put a run-off at A, a spring tongue switch, held normally for the cross-over at B and a run-off at C. The switch point at B should be on the outer rail to insure minimum wear.

THE Knoxville Electric Railway Company, Knoxville, Tenn., has turned a 14-foot car out of its shops. It does not intend to build its own cars, but was just seeing what could be done.



TRAILER SWITCH.

four overhead switches (twice for each one) is enough to recommend it without any further consideration.

We show herewith two engravings of the special work spoken of, as it appeared when being laid out on the floors at the Paige Iron Works. The yokes are made entirely of steel angle bars. The switch tongues are steel in castings faced with steel. At A is a run off but the slot at A is provided with a switch which springs itself so that it is always set for the main line. The spring of the slot rail accomplishes this so that it is perfectly automatic. The trailer switch at B is set by a spring for the crossover, so that the trainmen never have to bother with throwing switches. At C is a spring point switch which is held normally in position for the main line. As the trailers come onto the main line from the cross-over they open this switch against the spring but as the point is on the inside of the curve there is no

#### JAPANESE ELECTRICAL PAPER.

Electricians in Japan have a technical paper called "The Electrical Friend," which also circulates in China. It looks interesting, so our electrical editor says, but he has a short circuit on his Japanese, and cannot read the articles. The title page occupies what with us is the outside back cover, and the matter begins at the north-east corner and reads down and to the left. We are indebted to our friend, S. Katogi, Tokio, Japan, for a copy of this publication.

THE Union Street Railway Company, New Bedford, Mass., has passed into new hands. The officers are: Henry Crapo, president; Frank S. Stevens, vice-president; Charles F. Shaw, clerk and treasurer; E. E. Potter, general superintendent.

PERSONAL INJURY ACCIDENTS—THE MANAGEMENT OF EMPLOYEES, WITH REFERENCE THERETO.

BY A SUPERINTENDENT.

With the increase in street car traffic during the past few years the number of personal injury accidents has increased so largely, and the amount paid annually to settle the same assumed such enormous proportions that street car companies feel no little uneasiness in regard to this uncertain quantity. This naturally leads managers to seek the cause of the trouble, to obviate it if possible, or, at least, find some remedy by which it may be reduced to a minimum. In seeking this remedy we can come to but one point for consideration which offers any hope for relief, viz: the management of employes with reference to preventing personal injury accidents.

The writer of this article is the manager of the street car system in a town of some 50,000 inhabitants, which during the year ending September 1, 1894, carried nearly 5,000,000 passengers without either incurring one cent liability for any personal injury nor paying one cent for the same purpose. The policy pursued to attain this result is given below.

In looking over the record of various roads we find the per cent of accidents to the number of passengers carried, varies so largely that we are obliged to look beyond the natural and geographical conditions of the road for the cause of this difference. These may and will cause some variance, but we are firmly convinced that the main reason lies in the difference in training and discipline which different roads give their employes with reference to this branch of the business. It has been the writer's observation that on many roads it is a branch to which no attention whatever is paid until the accident occurs, managers simply taking their "accidental" pill as something that must be swallowed, and sit down resignedly to take it, consoling themselves as far as possible with the thought that it could not have been averted.

Too often the manager thinks it a useless task to spend his time teaching his employes the importance of being careful in this respect, because he can see no immediate financial return, except in an abstract way. Yet if he pause to consider the matter, how can he bring greater returns to his company than by eliminating these ghostly shadows, "damage suits," which hover over us by day and by night, threatening our very existence. If a motorman is hired he is put through a course of training in the shop to learn the various parts of a motor, etc., or a conductor is put on the road to learn the streets, but is one word said to him to show how a serious damage case may result from some trivial mismove on his part? He is "green" and does not understand the importance of this matter unless it is impressed upon his mind.

In many instances the entire control of employes is left to some foreman, a well-meaning and hard-working individual, yet who has no power of perception and who

cannot read human nature. His one object is to keep his cars running, and beyond this he cannot see. Though he tries to have discipline, and goes after his men sledge-hammer fashion, yet they soon learn his true caliber; and watch them as he may, they take advantage of him at every turn. The writer knows of cases where this state of affairs does exist—where accidents and breakdowns continually take place—and still the manager, seeking the cause, cannot see that it lies in the fact that there is something radically wrong with his system, and no one cares to tell him. If anyone did he would probably receive no thanks.

On another road, where the accident expense is something enormous, the writer has seen employes visit saloons while on duty; also a motorman and a conductor sparring on the front platform of their car while it was in motion. Is it any wonder this road's accident bill is large?

I hold that an employe should be studied, like a piece of machinery, in all its different phases; his weak places discovered, and quietly corrected. It is the only way to discover whatever merit he may possess, and to do this he must be watched while on duty and off.

The writer passes on all persons who are applicants for positions on his road, devoting a certain amount of time each day to this purpose. A glance, by experience, tells whether the applicant is a desirable quantity. If not, he is informed that there is no use for his services. On the contrary, if he seems likely he is given a blank to fill out, stating name, age, etc. His record is looked up, and nothing derogatory being found, when an opening occurs he is sent for and put to work.

His name is then entered, together with other data, in a book kept for that purpose, and all further breaches of discipline are duly recorded here also.

Politics and "influence" are allowed to cut no figure in appointments if the applicant does not give promise of being a success. Above all things, relatives and friends are shunned (especially the former) in making appointments. Nothing does more to make a set of men dissatisfied than to have appointments and promotions given to some friend or relative of the manager, and nothing is more conducive to their contentment than to make promotions from the ranks.

Again, one should know how his subordinates conduct themselves while off duty, as well as on—in short, to be successful in the matter in question, it is absolutely essential. A man cannot be out all night and do his work in the day satisfactorily. The writer has a system of espionage so complete in its details that it brings reports from all questionable resorts and many saloons as to the actions of employes while off duty. When a man visits these places a report is received, showing the amount of time, money, etc., spent there. If he goes to a certain limit he is called to the office and questioned in regard to his conduct. If he denies his conduct he is led on with his denials till he has entangled himself, when he is shown a record of his actions so complete in its details that it bewilders him.



The chances are that in the future he will never do anything but tell the truth. By pursuing this method the "bumming" element will be soon gotten rid of.

Ordinarily, the making of an absolute rule is inadvisable, as circumstances may arise under which it is best to make an exception to most any rule; whereas, if an inflexible rule has been given it is impossible to do this. Again, a rule should not be accompanied by a threat of dismissal. A statement of the simple order should be effective. Attaching the threat of dismissal for disobedience is not only superfluous, but it causes a feeling of animosity in the subordinate, which is undesirable.

The writer has in his possession a book of rules issued by a certain road, to conductors, which contains thirty rules, in which the word "must" (frequently with the words 'under penalty of dismissal') occurs thirty-six times.

A man sometimes becomes embroiled in an affair which would seem to warrant dismissal, but which may be overlooked, especially if he gives promise of becoming a valuable man with proper training. A case is called to mind when three young employes became intoxicated. Two of them were dismissed, while the third was retained, although all were guilty of the same offense. But the third was considered capable of becoming a skilful operative, and time has proved that no mistake was made. He was shown the mistake he was making and laid off for a time, when he was allowed to resume his position on two conditions:

1st. He was to drink no more.

2d. He was to put a certain amount of money in the bank each pay day. This amount was enough to take nearly all his wages outside of his expenses.

This happened some time ago, but the conditions have been faithfully carried out, and to-day there is no more faithful and attentive man to be found than this man.

The object of this was not so much a humanitarian one as it was this:

1st. If a man once gets started to saving money it is human nature for him to be anxious to get more. This makes him extremely careful to do well, that he may hold his position.

2d. If you have not misjudged your man he will prove a man on whom you can depend in every emergency.

The too frequent changing of men is the cause of many accidents. Unless some serious fault has happened it is not policy to displace a man. A proper course of discipline will have the desired effect. If you discharge him you must take a green man in his place, and you have no assurance the new man will be any improvement on the old, and you have simply got to go through a course of education with him to make him proficient. In writing the above I do not mean to say that discipline should be relaxed—on the contrary, it cannot be too strict—yet discipline can be enforced without brutality, and is far more effective than if enforced with it.

Men should be made to feel that a rule is a rule, and

as such is not to be violated, but at the same time he should feel the justice of any penalty inflicted for its violation. I have no patience with men of that ilk, which is constantly stirring up dissension, and the sooner it is gotten rid of the better. Fortunately there are comparatively few of them. Ordinarily men are men; to command their respect and sympathy is essential to success; their enmity is fatal. The service requires men of a higher degree of intelligence than in the days of "horse power," and it requires a higher degree of skill and tact to handle them. The model road is like a well balanced piece of machinery, where each part does its work well and without friction; but the best engine requires constant attention.

The writer devotes a certain portion of each day to riding over the different lines, always having in mind to caution operatives about accidents, showing them how some careless act on their part may lead to serious and costly results; how serious and how costly only those interested know. A notice is posted the first of each month and allowed to remain one week, calling attention to the liability of accidents and cautioning all employes to be careful.

Men are taught to be careful in small things. For instance, a supply of blacking is kept in their room that they may keep their shoes shined, and a box of metal polish is always there to keep buttons and badges bright. If they are required to be careful in small things they will be in greater ones. Any dissatisfaction and dissension is always reported by certain trusted ones. A reading room is furnished for the use of all employes, in which some leading papers and magazines are kept on file, all of which tends to attract a better class of men and make the position more desirable.

This in the main embodies the writer's system for avoiding accidents. To develop a system of espionage which has its ramifications throughout the city, including systematic reports from so many sources, involves a large amount of study and deeply laid plans. How it is to be done each manager must decide for himself.

Does the end justify the means? I know that many managers disagree with me on this point, holding that if a man does his work fairly well his time while off duty is his own. I grant it. But when a man transgresses the limit to such an extent that he cannot give you his best efforts, then it is time for the employer to assert himself. It is useless to think there is no dissipation among our employes. There is bound to be some in any body of men, although the extent to which it exists differs largely on different roads. Many managers, I imagine, would be surprised if they but knew the extent to which it existed on their roads. Many a serious trouble could have been averted had it been known in its incipency. To know these things requires continued vigilance. That I am right I am firmly convinced, and to substantiate what I say I mention the record of the above road: also the fact that with the accident insurance company which carried the same road (probably the strongest accident insurance company in the United States) it had the best

record of any road on its list for not having accidents, and the list is a long one.

NOTE—The amount paid for property damages by the above road, for the year ending September 1, 1894, was \$89.10, of which \$35 was attorneys' fees.

#### NEW TANDEM COMPOUND ENGINE.

Among the latest engines is the new tandem compound, of the Ames Iron Works, Oswego, N. Y., which

was designed by E. J. Armstrong, superintendent of the company. It is a high speed engine, in which the high pressure cylinder is placed next to the frame in such a manner that the piston and rod can be removed in the same way and nearly as easily as in a simple engine. The two intermediate cylinder heads pass out through the low cylinder. It is said that the advantage of this construction, is that the exhaust pipe is brought out of the way so that the sub-base extends way back, thereby giving sub-

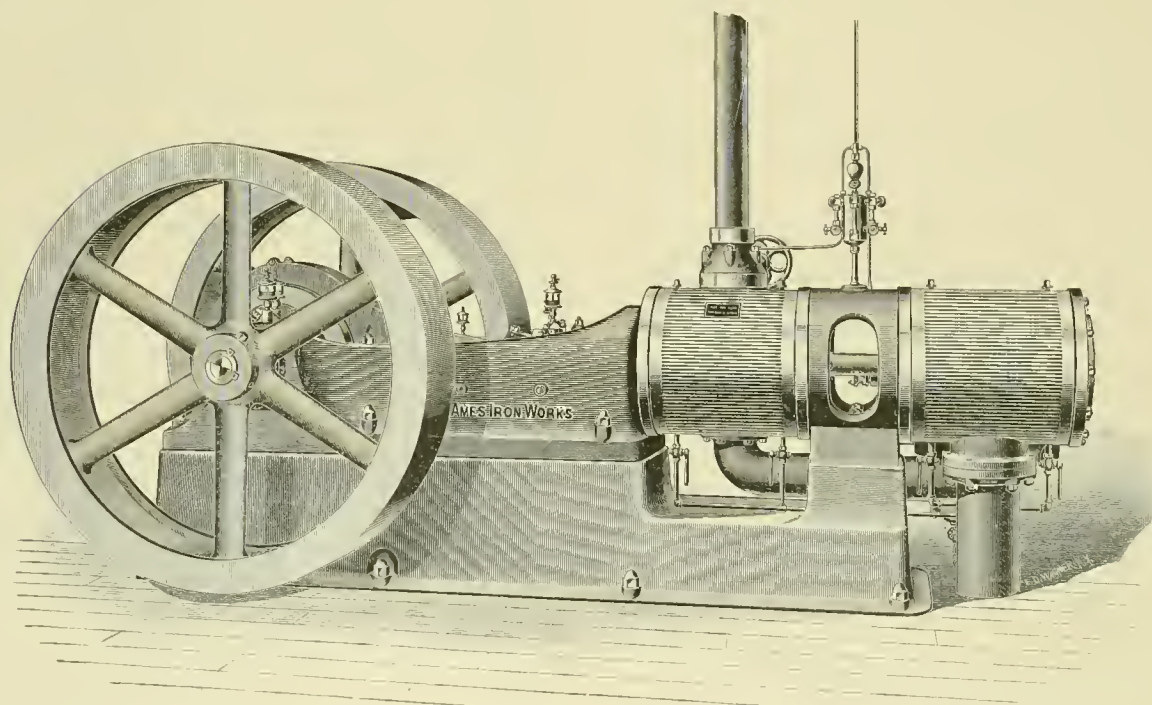
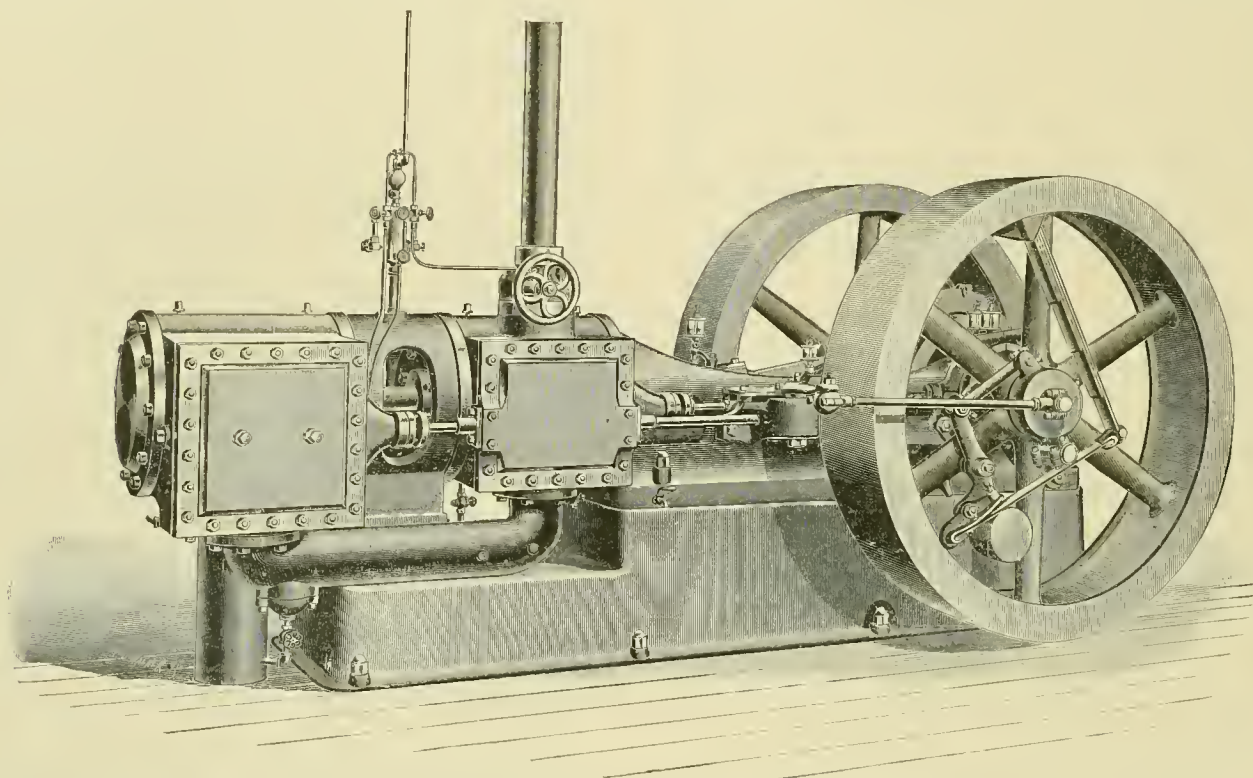

NEW TANDEM COMPOUND ENGINE.

stantial support to the low pressure cylinder. A novel feature in this engine is that cut-offs are on both cylinders, each driven by a separate eccentric, but controlled by one governor. The eccentric which drives the low pressure valve is shifted to a less degree than the one that drives the high pressure valve, so that while the latter is shifted through a range of from 0 to  $\frac{3}{4}$  cut-off, the low pressure changes from  $\frac{3}{8}$  to  $\frac{1}{2}$  cut-off. The link connecting the low pressure eccentric with the governor, has several adjustments, by which the low pressure cut-off may be made to vary, thereby securing best results under any conditions.

The engine is well constructed in all its parts. The packing is all metallic, and the packing of piston rods is such that leaks can only be from one cylinder to the other. One side of the engine is so arranged that it can be direct coupled to dynamos. All valve motions are on the other side, which is made in four different ratios of cylinder areas, and in sizes from 75 to 500-horsepower.

The pronounced success of the former products of the Ames Iron Works is ample guarantee that this, their latest and best, cannot fail to meet with a wide demand. Good materials; good workmen; and good ideas, the result of long experience and careful study, all combine to make the Ames engines serviceable, durable, and satisfactory.

---

#### FAR OR NEAR STOPS.

---

To stop on the far side, or near side of street crossings is a problem that has been solved for some companies by municipal authorities. There are arguments in favor of both methods, but some companies, which have been stopping on near crossings, have changed to the old style of stopping on the far side of streets. The chief objection to the near stop is, that passengers are compelled to alight in the mud when the streets are wet, while when the stop is on the far side, a clean crossing is secured on which they can stand.

A. W. Dingman, secretary and manager of the Toronto & Scarboro Electric Railway, Light and Power Company (Limited), Toronto, Canada, writes: "The Toronto Railway Company has adopted the plan of stopping at the nearest side of the street crossing. While in theory it appeared to be a great advantage over the previous arrangement, yet in practice it is developing an unthought of disadvantage, the result of which is, we may all die of pneumonia. The result has been to transform the front end of the car into the rear end, so far as the ingress and egress of the passengers is concerned. The front end of car, being the nearest to the passengers in waiting at the crossing, is almost invariably utilized for entrance and exit. In warm climates, this would not matter, but in these Northern cities in winter time, the result of such a practice cannot be otherwise than disastrous to the health of many of the patrons of the street car. This is the only objection so far developed, but it is a very serious one, and unless the street car companies are compelled to stop

all access to the cars by way of the front door, more harm than good will result from the change."

The Toronto Street Railway Company has had the system of near stops in practice for two months, and there have been no reasons for rescinding the order. It has proved decidedly that it lessens the number of accidents. The change was advertised thoroughly for a week before it went into effect, and there was little trouble after the first day. When the car stops on the first crossing, it gives teams time and warning to clear the way.

Philadelphia uses both systems of stopping. Where cars cross the tracks of other companies, stops are made at the near side of the street, but in other places some companies use one, and others the other style.

Charles O. Kruger, secretary of the People's Traction Company, says his company would prefer to stop cars on the far side of the street, but in order to harmonize with the desire of the Philadelphia Traction Company, decided to stop on the near side.

D. W. Dickson, treasurer of the Philadelphia Traction Company, says that the stopping of the cars of all the electric lines on the near side of crossings, lessens the liability of collisions.

Isaac Blum, vice-president and general manager of the Hestonville, Mantua & Fairmount Passenger Railroad Company, writes that the plan of stopping at the near side of street crossings seems to be appreciated by the public, which is in favor of the plan.

Frank Brown, president of the Baltimore Traction Company, Baltimore, Md., writes that the street railways of Baltimore are required by city ordinance to stop at the near side of the crossings. He also says that the system seems to work well with his company.

J. F. Heyward, general manager of the City & Suburban Railway Company, Baltimore, says: "The arrangement, in our opinion, has many arguments pro and con. I am rather inclined to think, however, that it is a fairly good arrangement. Of course at times it is disagreeable for the traveling public, say in cases where the streets are in a slushy, or muddy condition. I might add, that when we are stopping at the intersecting streets, on which the travel is not very great, we frequently throw the platforms of car to crossing, but, of course, this cannot be done on the main thoroughfares."

---

#### SKATING RINK AT DUBUQUE, IOWA.

---

President J. H. Rhomberg of the Dubuque Street Railway, writes us of a plan to turn the street railway ball park into a skating rink this winter. The ground is of the right shape and when cold weather sets in the surface of the ground will be saturated with water from the water company's mains. This will freeze so that it will make a good reservoir for the water that will subsequently be let in. When finished the rink will be 300 feet across.

---

F. S. Falling has been made manager of the Oswego Street Railway Company.

## A QUERY AS TO OPERATING EXPENSES.

EDITOR REVIEW:—In your issue of October 15, you give figures from the superintendent of an electric road, which show that he has reduced his operating expenses to the extremely low figure of seven cents per car mile. I know I shall be pardoned if I ask a few questions relative to this statement, as I am particularly interested in the cost of operating electric roads.

First. Cannot the cost per car mile be reduced to a still lower point by the addition to the service of more cars?

Second. Does a low expense per car mile always show that a road is being economically managed?

Third. If this particular road can economically operate for seven cents per car mile, why should its operating expenses be about 70 per cent of the gross earnings for the year ending June 30, 1893. (Verification may be had of this in "American Street Railway Investments.")

As 70 per cent of the gross earnings is about the average operating expense of a large number of roads which have come under my notice, we have the following paradox in the case of the road we are considering: An exceptionally low cost of operation per car mile has produced no beneficial results.

Therefore: It occurs to me that the expense per car mile may be reduced by the simple introduction of additional cars to the service; but that the introduction of these cars will be an economical proceeding is an entirely different matter. I do not write this as a criticism on the road in question, but simply to place this matter before the minds of thinking railroad men, that I may know if I am correct.

G. E. T.

In answer to the first question, it may be laid down as a general rule that the larger a road's business the less its expenses per car mile. For example, we can conceive of conditions under which a road might be able to double the number of cars in service without increasing its office or power house force. There might also be several other items that would remain the same if the number of cars in service were doubled, and hence there would be a decrease in the expense per car mile. If a road is working up to its full capacity in all departments, any increase in the number of cars will result in a very nearly proportional increase in the total operating expense, and consequently the car mile expense will remain the same. It very often happens that a road is operating a power station much below its maximum capacity, and in such case the cost of power per car mile is decreased by adding cars. It is also true that it would decrease the car mile expense to run the same number of cars from the time of starting in the morning until shutting down at night, but such a procedure would, evidently, not be a paying one on any but small roads.

This brings us to the second question. A low car mile expense shows that the road is being economically managed, as far as the simple movement of cars over the road is concerned, but it gives no clue as to whether a

manager is giving a more frequent service than the traffic warrants. The operating expenses are entirely separate and independent of the earnings. A road could be operated very economically without carrying any passengers whatever. The frequency of the service that a road should give its patrons is a perplexing question, and one on which the manager has no other guide than his judgment. The more people that can be carried with a given number of cars, the greater will be the earnings of a road relative to its expenses. But right here comes in the consideration of inducing traffic. A road might make money for a short time by crowding its passengers into as few cars as possible but there are very few that could afford to do so long. A frequent service induces travel, and it is for this reason that it is an almost universal custom for street railways to give a somewhat better service than the traffic calls for. This policy is not the most economical one for the time being, but it builds up a business, and pays in the long run. As to how much better the service should be than is demanded by the traffic, is a local matter, left entirely to the judgment of the manager, as was said before. We do not think any manager would be guilty of running a lot of extra cars, just for the sake of cutting down car mile expense!

In answer to the third question, it is necessary to ask another. What condition would the road be in if the operating expenses were not as low as they are? It is not fair to apply data obtained from other roads to a particular road without making sure that the conditions are the same. If the low operating expenses have produced no beneficial results on the road in question, let it be considered for a minute what would be the effect if they were higher. It is not within our province to inquire into the frequency of the service given on this road, because that is a matter dependent on local conditions, with which we are not acquainted; but with the same service that is given now, an increase of four cents a car mile would turn the road into a money loser, and its expenses would still be less than many other roads of its size. A decrease in the number of cars might increase the expense per car mile slightly, but it will not do to jump at the conclusion that the operating expenses per car mile depend entirely on the number of cars run, or that low operating expenses per car mile are not a benefit worth striving for.

To sum up, we may say that the car mile expense may in some cases be slightly reduced by adding more cars to the service. This is not necessarily so in all cases. Whether this move is good economy depends entirely on outside circumstances, which have nothing to do with the operating expenses, just as the cost of manufacturing goods is independent of the demand for them.

EDITORS STREET RAILWAY REVIEW.

P. H. Carey, western agent of the Phoenix Iron Works, Meadville, Pa., was called east on account of the serious illness of his sister. His many friends in the street railway field will be grieved to know that death occurred before his arrival.

EXPLOSION IN ELWOOD, IND.

On the night of November 16 the boiler of the Elwood Electric Street Railway Company, Elwood, Ind., exploded, wrecking the plant, together with car house and all the cars of the company. The loss is about \$20,000. The electric light plant will be duplicated, but nothing will be done with the street railway system until spring.

The exact cause of the explosion is not known, perhaps it never will be known, for the engineer is dead. A man who was in the boiler house a few minutes before the explosion occurred is positive that the gages showed plenty of water in the boilers. The force of the explosion was so great that a large section of the boiler was blown quite a distance. Although only one explosion was heard, the other boiler was twisted out of shape.

It was soon after midnight when Frank McDonald left Norman Clark, the engineer, to go to the car house. He

SURELY OUGHT TO BE ABLE TO CONTROL HIS HALF.

R. D. Rowe, late superintendent of the South Chicago City Railway Company, had a caller recently who introduced to him a novel proposition. In connection with the Calumet road a target tender is employed. For some reason or other the visitor, who was under the influence of liquor, had a grievance against the target man, and asked for his discharge.

"Shay," said he, "are you shupertenant?"

"Yes, sir," replied Mr. Rowe.

"I wantsh that target man bounced."

"He is a joint man employed by both companies, and I have no power to discharge him," said Mr. Rowe.

"Cantsh you reprimand him?"

"No, he's a joint man and I can't even reprimand him."

"I sh'd think you could reprimand your half," said the kicker as he left the office.



"ALL TWISTED OUT OF SHAPE."

had got down into the pit, under a car, when the explosion came, and the roof of the car house fell on the four cars beneath it. McDonald climbed hurriedly from in under the car, which was crushed by the falling bricks and beams, receiving some slight injuries. The ruins caught fire, which was soon extinguished by the firemen who were early on the scene. A rescuing party discovered the engineer near a dynamo with an oil can in his hand. He was unconscious, and his body was frightfully burned and scalded. He survived only a short time. The illustrations give some idea of the destruction that was caused.

HAS COME AT LAST.

Even the inoffensive trolley car has not been spared by the playwrights. "The Trolley System" has been on the Pennsylvania circuit. It is said to be a new farcical comedy in four acts, in which "there is more dialogue than is usual with entertainments of this class. Each act is staged with special scenery, which fills an entire car."

Mr. Rowe is still undecided which half to reprimand and wants advice.

NEW ELECTRIC LINE IN DUBLIN.

Under the direction of J. Clifton Robinson, C. E., managing director of the South Dublin line, and electrical tramway expert to the Bristol and London United Companies, \$600,000 is being used in the construction of an electric railway, to take the place of the horse line. It will have eight miles of double track, 76-pound rails, laid in concrete. The contract requires the completion of the line by May 1, 1895, and it is being rapidly pushed. Trains will consist of two cars, the trailer being drawn by horses in the city, where no electrical provision has been made. It is said the rails will be double-tracked for the whole of the distance, thus largely avoiding something approaching the feeling of sea-sickness, which passengers traveling in trams over badly made lines not unfrequently experience. This is a strange comment to American ears. Cars will be run under headway of five minutes.

## OVERCROWDING CARS.

Every street railway manager and superintendent, probably, hears more complaints about overcrowded cars, than concerning any other branch of the service. In spite of the discomfort of standing it seems to be a trait of humanity to crowd into the first car that comes along, regardless of the fact that within a minute or two another car will arrive with empty seats. People rather enjoy standing and hanging on the straps, when they have become accustomed to it, for it does not take them long to get in that condition where they would just as leave stand as be seated. Still managers had rather see their patrons comfortable than discommoded.

Until human nature is changed there will probably be crowded cars in the large cities. The Broadway and Third avenue cable lines, New York, show this trait of human nature. During the rush hours cars follow each other so closely that in many cases there are two in each block.



"TAKE THE NEXT CAR."

Often the first car will be crowded, while the second will be practically empty, yet the conductor of the first car cannot keep people from hanging on.

Last month the Montreal Street Railway Company, Montreal, was fined \$1 and costs in each of two cases, for violating an ordinance fixing a penalty for receiving more passengers than cars would comfortably hold. The ordinance is a relic of horse car days, when the number of passengers each car could hold was posted. This was made necessary on account of the grades. Now that electricity has been adopted, there is no reason for such a law, and it should have been repealed. At any rate it is not being enforced, for a day or so after the fine was imposed, the official whose duty it was to prevent overcrowding was directed by his superiors to desist.

T. B. Warren, editor of the "Patriot," heard complaints of overcrowding, so he informed the officer whose duty it was to enforce the ordinance, that it was being disregarded. The latter did his duty. Mr. Warren would have a law passed under which a would be passenger who persists in pushing his way into a filled car, could be turned over to the first policeman and arrested for trespass. Mr. Warren would go farther and have the conductor arrested who permitted his car to become crowded.

Granville C. Cunningham, manager of the company and city engineer, writes, "The company does not wish

to have the cars overcrowded, but it seems to be impossible by ordinary means to prevent people from forcing their way in, whenever they can obtain a foothold, struggling and pushing often in a most discourteous fashion. What is the conductor to do? Is it to be expected that he should beat these men off with a club, or take them by the collar and jerk them off into the street? If he tells them to take the next car he is only "chaffed" in return. If on the company is to be thrown the onus of keeping the people off the cars, we will have to engage and train sluggers and bullies, who will fight on the smallest provocation and not hesitate to throw men into the street when they force their way on to a crowded car. Extra cars do not meet the requirements, as everyone wishes to get on the first car and will not wait for the next, which is only half filled. The Paris system, where every passenger has to wait at a street corner and get from the man in charge a number before he can enter a car, and the car has to wait until the passengers are counted like so many sheep before they get their places, will not suit the people of Montreal, who have to hurry sometimes, and the Paris plan does not contemplate such a state of affairs.

"The simplest means of all for preventing overcrowding is for the citizens themselves not to overcrowd the cars. There is not another city in Canada, nor in the United States where there is any regulation that punishes a street railway company because the citizens crowd its cars."

## GIVE ME A MATCH.

A horse car conductor was transferred on to an electric line in Chicago the other day, and as darkness approached walked proudly over to the lamp switch to turn on the electric light, congratulating himself, meanwhile, that "things were not as they once were" and that his days of lighting lamps with matches were over. The car floor was wet and he managed to get his fingers on a live spot of the lamp circuit in some way, so that when he tried to turn on the lights he got a good hard shock. After he had jumped half way across the car, and began to realize what had happened, he looked around in a confused way and exclaimed: "Give me a match." He had no further use for the modern way of doing things.

Another man on the same road, who was fortunate enough to get an electric run, was accosted by a fellow employe late one afternoon and asked where his lamps were. The car was several miles from the barn and darkness was fast coming on. "By George," said the dismayed conductor, "I've come off and forgot my lamps." A few minutes later the motorman turned on the light, and the conductor collapsed.

Sanford, Brooks & Bonsal have received the contract for constructing the double track electric road connecting Pittsburg with McKeesport, with a branch to Homestead.

## SIMPLE TICKET RECORDS.

For six months the Santa Cruz, Garfield Park & Capitola Electric Railway Company, Santa Cruz, Cal., has had in operation a coupon system. The coupons are similar to those in use on other roads, but Manager F. W. Ely has a simple and accurate system of keeping an account. Each person receiving a book is given a permanent number, and when another book is given him 100 is added to his individual number. It has been objected that in cases where a large number of free passes are issued, the hundreds might be so high as to require four or five figures, which would be likely to be

on the back over his own signature the man's name. For employes, books with a less number of coupons can be issued without numbers, thus keeping numbers for the 'free list.' The coupon books issued by our company for the 'free' are the same size and color as the commutation book tickets (25 rides for \$1), so that none except the conductor knows who is riding 'free,' and the conductor is compelled to account for every passenger in his car. We have found this system very satisfactory."

The conductor's daily report blank used by the company has a place for the number of motorman and conductor and for the conductor's punch. Each trip must be reported, showing time, number of trip, car number, miles, fares, transfers, passes. On the reverse must be placed a list of persons passed, or their numbers and the time. There is also a summary for car miles, passes, city employes, commutation, school, and transfer tickets collected. Cash fares, total passengers, and a blank for cashier's signature for cash fares received. The daily report of the cashier is shown herewith.

The Columbus, O., Street Railway Company has adopted a simple method of keeping track of ticket sales. Two styles of tickets are used, the conductor starting with \$5 worth of one kind and \$6 worth of the other, which are charged against him. Instead of turning in an account of sales at the end of the day, the money from the sale of tickets is used in purchasing other tickets, simplifying accounts and preventing errors.

**Car Receipts--Santa Cruz Electric Railway**

Day of Week *Thursday* Date *Nov 22 1894*

CONDUCTORS	PUNCH READING		NO PASSES	CITY EMPS	COM TICKETS	SCHOOL TICKETS	TRANS FERS	CASH FARES	CASH RECEIPTS
<i>Jones</i>	<i>pm 5400</i>								
	<i>am 4400</i>	<i>1000</i>	<i>100</i>	<i>100</i>	<i>700</i>	<i>50</i>	<i>50</i>		<i>00</i>
<i>Brown</i>	<i>pm 600</i>								
	<i>am 500</i>	<i>100</i>	<i>1</i>	<i>1</i>	<i>1</i>	<i>1</i>	<i>1</i>	<i>95</i>	<i>475</i>
<i>Smith</i>	<i>pm 550</i>	<i>10</i>						<i>10</i>	<i>50</i>
	<i>am 550</i>								
<b>TOTALS</b>									
			<i>101</i>	<i>101</i>	<i>701</i>	<i>51</i>	<i>51</i>	<i>105</i>	<i>525</i>

MILEAGE REPORT	CONDRY TIME	C <sup>1</sup>	C <sup>2</sup>	C <sup>3</sup>	C <sup>4</sup>	C <sup>5</sup>	C <sup>6</sup>	C <sup>7</sup>	C <sup>8</sup>
<i>Jones</i>	<i>10</i>	<i>40</i>		<i>30</i>					<i>70</i>
<i>Brown</i>	<i>13 1/2</i>	<i>10</i>			<i>50</i>	<i>40</i>			<i>100</i>
<i>Smith</i>	<i>9</i>						<i>79</i>		<i>79</i>

*F. W. Ely -* CASHIER

## OBSTRUCTION NUISANCE SUPPRESSED AT TROY.

The Troy City Railway recently had a little trouble with some people who seemed bent on causing the public as much inconvenience as possible, but they were soon suppressed. A firm of boiler-makers, at Green Island, N. Y., had two boilers to move to the Troy waterworks pumping station at Lansingburg. Each boiler weighed about fourteen tons. The movers used the Troy City Railway tracks for about two miles. When about half-way with the first boiler one of the wheels of the heavy truck broke, and it was impossible to get a wheel that would take its place. While the wheel was being fixed there was a delay of about twenty-four hours. Moreover, the boiler, when on the truck, was dangerously near the trolley wire. When it came time to move the second boiler, Superintendent C. H. Smith of the City Railway notified the boiler people that they must not use the street railway tracks for that purpose, except between midnight and 5 o'clock in the morning. They replied that they would move it as they did the first one, whereat the railway obtained an injunction, which had the effect of keeping them off the track and compelling them to use other streets.

The Versailles Traction Company, which owns right of way from McKeesport, Pa., to Boston, four miles, has begun to run cars.

cumbersome. In regard to this point, Mr. Ely writes: "Assuming that a large company has 999 people entitled to a free ride, and issues books containing 50 or 100 rides. If A, who is number 3, receives a book of 100 rides, his second book will be No. 103, the third 203, and when he has received his No. 903, it will make ten books of 100 rides each. When he has received his book 1903, he will have had twenty books of 100 rides each. That is a good many rides and only four figures. Next year a letter can be added making the number 3a. The next person receiving a book would have No. 4, and the one who followed him would be No. 5. Should the manager or superintendent wish to send a man over the road for one trip, he can tear out coupons, endorse



MOTOR CAR AND TRAILER OF AN ELECTRIC CONDUIT ROAD—MADRAS, INDIA.

### THE MADRAS TRAMWAYS STARTED.

The slowness which usually marks the movements of affairs in tropical countries does not seem to characterize our street railway brethren of Madras, India. It was only last January that the inaugural ceremonies of the construction of the Madras tramways took place. Engravings from photographs taken at the time were pre-

sented to our readers in March. It was not to be expected that work would advance very fast in a country where no similar work had been done, but the progress has been truly remarkable, as can be seen from the views presented herewith. In fact, it puts to shame the street railway work done in some hustling cities in northern climates. It will be remembered that this is a conduit road somewhat similar to that at Budapest. It was



CHARACTERISTIC SCENE—MADRAS, INDIA.



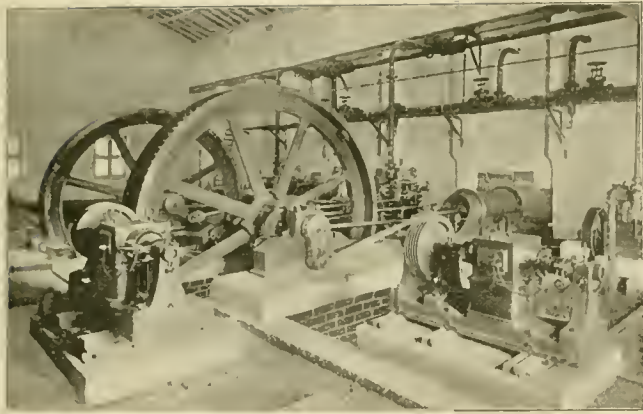

POWER HOUSE—MADRAS, INDIA.

designed by Thomas Parker, the well-known English electrical engineer, who was so prominently connected with the electric elevated road of Liverpool, the first commercial electric elevated road in the world.

The Madras road is unique in more respects than one. Indeed, it has lost so many of the usual characteristics of the electric road—as we in America know it—as to be scarcely recognizable. The peculiar cars, their still more peculiar inmates, and the absence of overhead trolley all combine to give the outfit a strange appearance to the ordinary electric railway man.

We are able this month to present a likeness of the leading spirit and managing director of the enterprise, S. A. Chalk. Mr. Chalk received his education at the Middle School, Chester, England. At fifteen he began to qualify as an accountant, and after seven years at Liverpool he took charge of the counting-house of one of the largest Australian companies in London. After two years of that he became partner in the firm of William Hutchinson & Co., the East Indian merchants, who obtained the concession for the Madras electric tramways. Mr. Chalk took a most active part in the gaining of the franchise.



S. A. CHALK.

His extensive business relations with that country and his frequent visits in connection with the firm's business give him a knowledge of India which is of great value to the company of which he is managing director. The new road has created the most intense curiosity and interest throughout India, and can hardly fail to be speedily followed by others. It deserves success and has already entered on a good business. Its future operation and development will be followed with interest by electricians and railway men, both here and abroad. The mechanical conditions for operation would seem to be very favorable, and the public are already educated to riding, so that modern facilities should combine to make the enterprise a very desirable one.

THE Hartford (Conn.) Street Railway Company, sells its old cars for \$8 each.

### USE OF ELEVATED STRUCTURE FOR A RETURN.

A most remarkable decision was recently made in Brooklyn regarding the use of an elevated railway structure as a conductor for an electric railway return circuit. The Atlantic Avenue Railroad has a contract with the Brooklyn Elevated Railroad, whereby the former is allowed to hang its electrical conductors on the structure. The elevated road began to take down the conductors on the ground that the wires had not been attached in accordance with the contract, because none had been placed for the return current, and the telephone and telegraph circuits on the structure were disturbed. An injunction was applied for by the surface road to prevent the taking down of the wires, but Judge Gaynor of the Supreme court refused to grant the injunction and made the following memorandum:

“By written agreement between the parties to this action the plaintiff is given the right ‘to attach to and place on and along’ the elevated railroad structure of the defendant ‘such number of electric wires and electric cables’ as the plaintiff may require in the operation of its surface railroad by electricity. The plaintiff has placed wires and cables along such structure to carry or transmit electric currents from its power-house so as to propel its cars, but instead of so placing their wires for the transmission of the currents back to the power-house, as to complete the necessary circuit to get electric energy, it uses the structure of the defendant as an electric conductor for that purpose. The contract gives no such right. It only gives the right to string along the structure wires and cables necessary to transmit the electric current. The contract is in no way obscure or doubtful. A circuit of the current being essential, the contract plainly is that the wires to complete such circuit may be attached to the defendant's structure. The motion is denied, with ‘no costs.’”

The peculiar thing about the decision is the fact that the interference due to the ground return has nothing to

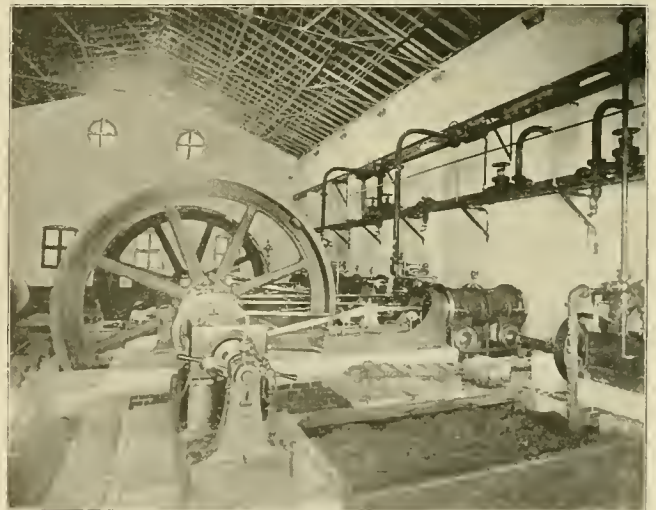

POWER HOUSE—MADRAS, INDIA.

do with the stringing of cables under the structure, and that even if the return is not connected to the structure the disturbance would be as bad or worse. If the return current could be prevented from seeking the elevated structure the case would be different, but as it is the refusal of the injunction simply means that the law upholds the elevated company in taking out its spite against the surface road for disturbing its telegraph service. Connection of the return to the elevated structure rather diminishes than increases difficulties.

#### A DEVICE FOR MECHANICALLY DISCONNECTING MOTORS.

A problem of considerable importance has been confronting the three great street railway systems of Chicago ever since the reconstruction of the horse lines into

that considerably more power will be required than would be the case with an ordinary trailer, on account of the high speed motor armatures.

The problem of disconnecting the armature gearing so that the armatures will not revolve is apparently a very perplexing one, especially considering the fact that but a few seconds can be allowed in which to perform the operation. A very simple solution has however been found by J. R. Chapman, who has charge of the electrical department of the West and North Chicago Street Railroads. In fact, a man who has given the subject some unavailing thought and is shown Mr. Chapman's device, is reminded of Columbus and the egg: "It's easily done when you know how."

The car axle bearings of the motor are cast inside an eccentric brass sleeve, which extends the length of the axle. This sleeve is split and takes the place of the

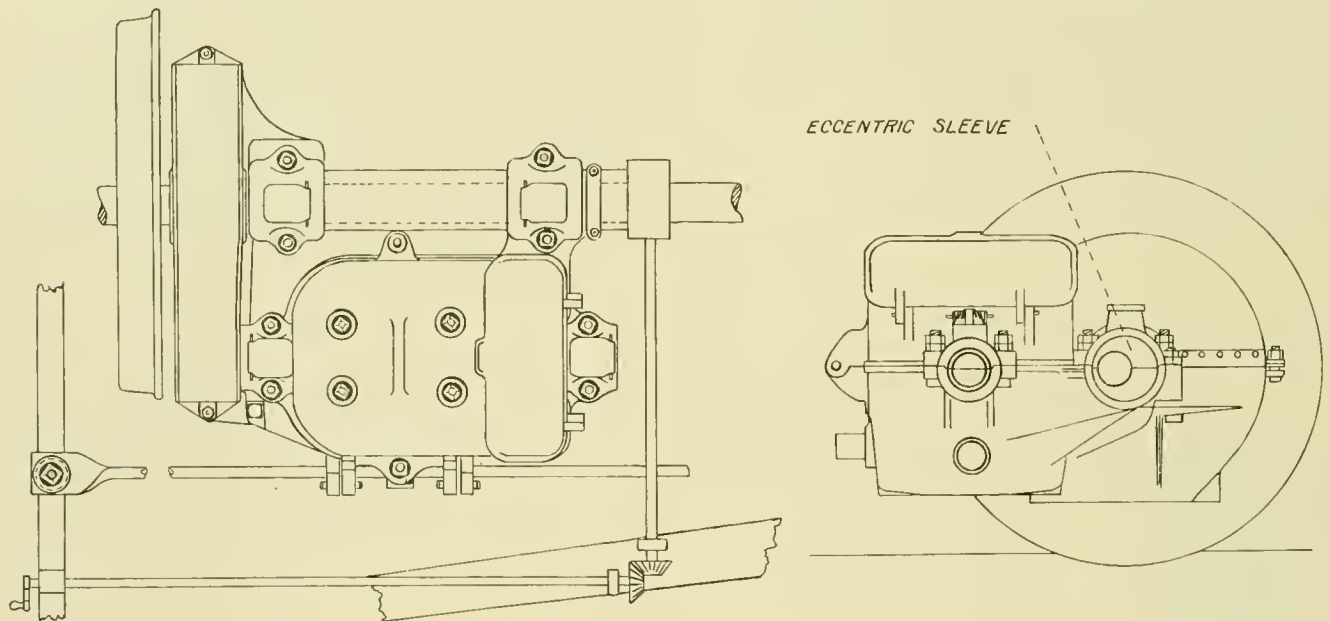

CHAPMAN'S MOTOR DISCONNECTING DEVICE.

electric lines began. There are to be certain electric lines which run as feeders to the cable lines. That is they carry passengers to within a short distance of the heart of the city and then connect with the cable. It is customary at present with horse traction to unhitch the horses from each car as it arrives at the junction and haul it around the down town loop as a trailer on a cable train. When electricity is adopted, it will either be necessary to transfer the passengers and let the electric car go no further or hitch the motor car to the cable train and haul it around as a trailer. Either of these expedients seems at first thought to be very undesirable. It is not advisable to transfer at these points, because the incoming cars are crowded with passengers, nearly all of whom are going down town. If they are transferred, provision must be made for them on the cable trains. This means that a lot of empty cars must be hauled from the cable car barns, several miles out, simply to accommodate passengers around the down town loop. If the motor cars are hauled as trailers, there is the objection

ordinary journal box sleeves. The eccentric sleeve is made so that it can be turned around in the motor journal boxes. By turning this eccentric sleeve around one-half a revolution, the motor can be moved three quarters of an inch toward or away from the car axle, and the gears thus brought into or out of mesh. The rotation of the sleeve is effected by a worm gear. The worm gear shaft runs lengthwise of the truck until about midway between the axles where it connects by a bevel gear with a shaft running parallel with the axles and extending out to one side of the truck, where provision is made for attaching a controller handle as a crank. The shafts for both motors come out on the same side of the truck.

A car equipped in this way has been fitted up by the General Electric Company for Mr. Chapman, and has had several trials around Chicago. It takes about thirty seconds to disconnect both motors. Some inconvenience has been found on account of the gears not meshing when an attempt is made to throw the motors in gear. According to mathematical calculations this will probably

occur about one-third of the time before the pinion is worn, and less than this as gear and pinion are worn down. The results as to the comparative power consumed with the armatures running and at rest were disappointing in one sense and encouraging in another. As showing the small mechanical loss in the armature of a motor they are encouraging. The saving with the armatures thrown out was very much less than the majority of engineers would expect. Dynamometer tests on horizontal effort were, of course, dependent very much on the condition of track, but the pull averaged about 350 pounds with the armatures out, against 450 with the armatures in gear.

The device itself is certainly about as simple and effective as it is possible to make it. As to whether the power saved is worth the extra expense and trouble involved is still an open question.

### CABLE AND ELECTRICITY IN CALIFORNIA, COMPARED.

A western engineer has been looking into the relative cost of construction and operation of the two systems as working in San Francisco, and while the comparison is in some respects a local one, yet in the main it is fairly stated as to large cities generally, especially as to the great arteries of travel. The item of cost of cars it must be remembered is Pacific Coast prices.

The report states:

"The San Mateo electric road, as operated to-day, requires as much horse power to operate it as the whole original Market street system—that is, Market street, Valencia Haight, Hayes and McAllister streets combined.

"The comparative cost of the motive power of cable and electricity is very much in favor of the cable road, provided the number of cars are in excess of say from thirty to forty.

"No single electric car can be operated with less than from ten to fifteen horse-power, this ratio remaining the same no matter how great the number of cars operated from the one power plant, while the average horse-power expended for each cable car operated here (San Francisco) is less than five. The ratio of horse-power per car decreasing as the number of cars operated by the cable is increased; for example, it would require from 10 to 15 horse-power to operate an electric line of one car and from 500 to 750 horse-power to operate the same line with 50 cars.

"In the case of a cable line it would require 50 to 70 horse-power to operate a single car line and about 250 horse-power to operate 50 cars on the same line.

"On a steep grade where a single electric car would require at least 50 horse-power to propel the same, a cable car would require no more and perhaps less than on any other part of the road, as the cars returning down the same hill or a like hill would balance those going up, and the power expended to propel either would be nominal.

"Rails used on the electric road bed must necessarily be heavier than those used on a cable, as an electric car empty weighs more than a cable car of the same capacity and its load combined. With regard to the cost of the same, electric cars fully equipped with two motors cost from \$5,000 to \$6,000, whereas a cable car of the same capacity with grip and brakes complete, would not cost to exceed \$2,000. While the cable road is cheaper to operate, the cost of construction is in favor of the electric road.

"Each single track of the present Market street cable originally cost about \$100,000 per mile, but material—and rails especially—were expensive when the road was built; rails costing at that time \$70 per ton can be duplicated to-day for \$40.

"Electric roadbeds do not necessarily need steel and concrete construction, therefore electric lines similar to Mission street can be built for half the cost of cable lines, or about \$25,000 per mile, single track, while that on Kearney street, that is with concrete foundation, from \$30,000 to \$35,000 per mile. This is on the basis of single track, but electric roads seem to be the most popular to-day. The difference in the cost of building them, the speed obtainable and the electrically lighted cars are all inducements to the contemplating builders to use the same on streets with gradients not exceeding one in seven."

### HOW NOT TO PREVENT SAFE ROBBERIES.

An ingenious business man, of Utica, N. Y., hit upon a novel plan for preventing safeblowers from robbing his strong box. The expedient got him into trouble, for a coroner's jury was compelled to expose his secret. The man, whose name is Goldstein, set an iron plate in the floor in front of his safe and connected both it and the safe with an electric light circuit. A person standing on the plate and touching the safe made a connection. Customers of Goldstein knew of the device, but supposed the electricity was generated in small batteries, as it was customary to shock those unacquainted with the trick. One afternoon the current was on, when Stuart England stepped on the plate and touched the safe. The shock killed him. A coroner's jury decided that Goldstein had no excuse for maintaining a death trap in so public a place as his store, ready charged for the first person who came in contact with it.

The scheme has little to commend it, for the professional burglar could easily make the test with a piece of wire, and if the current was found to be on, protect himself by breaking the circuit or insulating himself. At the same time there is the constant danger that some one for whom it was not intended will get the medicine.

The North Chicago Street Railroad has awarded contracts for four 1,000-horse-power Allis engines and four General Electric generators for its station at Hawthorne street and the river. The station foundations are being put in.

## GREAT ELECTRIC RAILWAY SYSTEM.

Hamilton, Canada, is to be the center of a great electrical railway system which is being constructed by the Hamilton Radial Railway Company. The accompanying map shows the points which the system will embrace. There will be 227 miles of road, made up as follows: Hamilton to Toronto, 39 miles; Hamilton to Guelph, 29 (to Fergus, 21); Hamilton to Gault, 23 (to Waterloo, 35); Hamilton to Brantford, 22, (to Woodstock, 48, and to Port Dover, 49); Hamilton to St. Catharines, 33, (to Niagara Falls, 45, and to Buffalo, 67). The road will be up to steam road requirements, only the lines to Waterloo and Fergus being equipped with electricity.

This system of railways is designed to make the city of Hamilton the greatest commercial center of the Niagara peninsula, which includes a large fruit growing and farming region. To collect and bring the produce of this section to one point was the object which has engrossed the attention of John Patterson, who is about to see this plan perfected. Three of the branches will be built and equipped as steam roads, as a portion of the line from Niagara to Woodstock will be used as a link for a fast train service from New York to Chicago. The plans of the company contemplate the shortening of the distances between many of the towns, as compared with that of roads now in existence, in some cases from one-half to one and one-half miles, and in others one-third to one-half the distance is saved.

Another advantage over existing lines, will be the frequency of trains. In one place for instance, where, under present conditions, it is necessary for a man to rise a 5 a. m. to reach Hamilton and return the same day, the Hamilton Radial Railway Company will have cars running every hour, making the trip in thirty to forty-five minutes. The system will also reach one-half the coal consuming population of Ontario, and will supply transportation to a population of about 700,000 persons, or about one-third of the entire population of the province.

The territory is served by the Grand Trunk Railway and small branches of the Canadian Pacific and the Michigan Central Railroads, but as will be seen on the map, they do not cover the field, as the Radial Company proposes to do. The prospects for revenue are good.

Bonds are being issued with ten years' interest paid up, making the stock the only claim on the net earnings for that period. It has been estimated that it is only necessary to earn \$1,400 per mile to make 7 per cent, and this is such a small amount to be expected from a territory so rich in resources, that the most sanguine expectations of the people interested in the enterprise are likely to be exceeded.

Work of construction has been delayed for some time on account of the large expense. But now the cheapness with which a first-class road can be constructed as compared with the cost a few years ago, has removed that obstacle. The eyes of all persons interested in electric railways, will be turned towards this road, as the work of construction progresses, for particular attention will be

paid to the development of high speed on its electric lines. Plans are being made and figures prepared with the expectation of handling 50-mile transmissions commercially, using the three-phase system at 20,000 volts pressure. At present the plans have not progressed sufficiently for details to be presented, but engineers are confident this prodigious feat can be accomplished.

The Hamilton Radial Railway Company is incorporated with \$2,000,000 capital, being owned largely by Boston and Eastern capitalists. It is reported that the Canadian Pacific Railway Company is also interested. The company

will probably use the charter of the Canadian Pacific for a line from Hamilton to Woodstock, with a promise of the usual Dominion subsidy of \$3,200 a mile, and the charter of the Niagara Central from Hamilton to Niagara Central with a bridge franchise. Recently was purchased the St. Catharines & Niagara Central Railway which runs twelve and one-half miles to Niagara Falls on the way of the system. It is expected that the city of Hamilton will give a bonus of \$400,000 on account of the benefit the road will be to the city.

H. B. VAN SICKLE, 321 Superior street, Toledo, Ohio, is making arrangements to construct the Delaware & Centerburg Electric Railway, and is in the market for six miles of second-hand 60-pound steel T rails, full length, to be shipped to Delaware, Ohio. Offers should name price delivered at Delaware. When completed the road will have twenty miles of track.

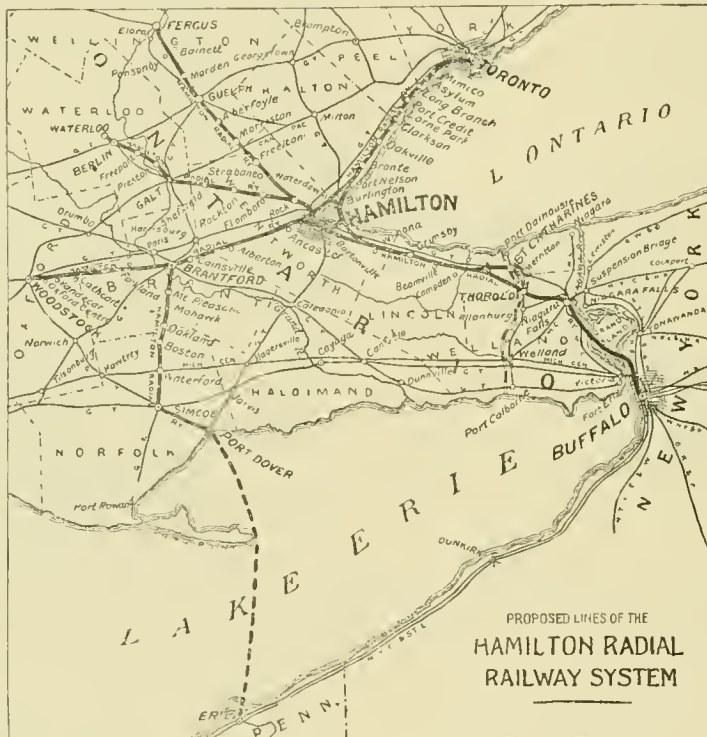

## LENOX AVENUE CONDUIT ROAD, NEW YORK.

Metropolitan Traction Company's Experiment—General Electric Company's Solution of the Problem—A Miniature Pole Line Underground.

The electric conduit railway which is being built by the General Electric Company for the Metropolitan Traction Company of New York, on Lenox avenue, is of unusual interest because it will be the first conduit laid in this country with the endorsement of a large and long established electric manufacturing concern. This

to a cable conduit, except that every thirty feet are man-holes 4 feet 4 inches deep. The conductors are channel irons and are supported every thirty feet by soapstone pillars 13½ inches high. These soapstone pillars are set on iron pillars placed in the manholes. Between the iron pillars and the soapstone is a layer of sulphur. The accompanying engraving shows both the manhole and the yoke. The use of channel irons for conductors obviates many difficulties that have in the past beset conduits using wires. A conduit does not allow of much movement, and a good deal of trouble has been experienced on account of the stretch of the wires. This difficulty made frequent supports necessary, and frequent

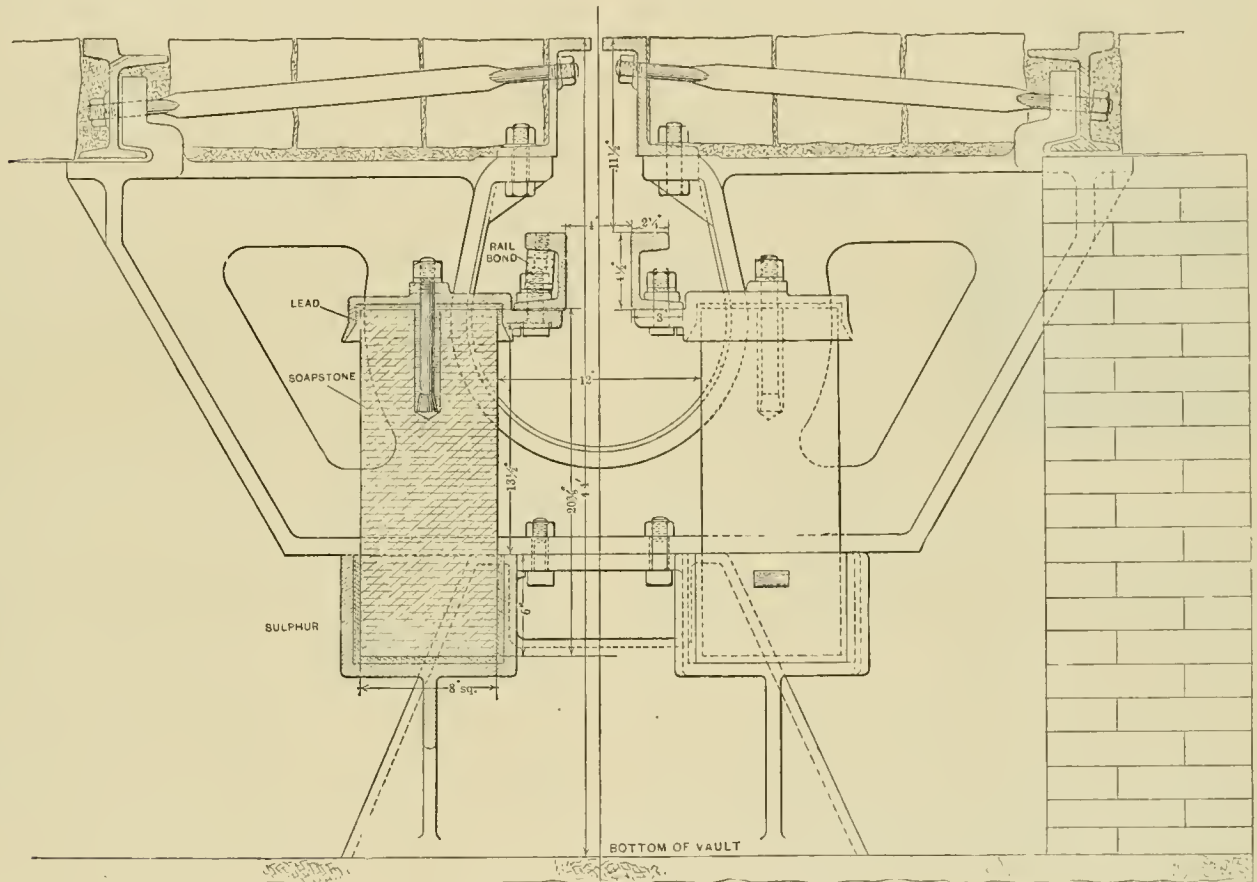

NEW YORK CONDUIT—LENOX AVENUE.

does not mean that the large concerns have not done a great deal of private experimenting, but that those experiments and the experiments of others have had such unfavorable results that no concern of established reputation cared to lay a conduit for regular commercial use. Then, too, there were so many other electric railway problems to be solved which promised good results that the underground conduit business which gave so little promise of success had to take a back seat. The conduit being laid at New York bears marks of being planned by a corps of experienced electrical engineers who thoroughly understood the difficulties to be overcome, and in this respect is a marked contrast to some experimental lines that have been laid in this country.

The conduit laid on Lenox avenue is exactly similar

supports increase the chance of leakage and breaking of insulators, as well as causing more sparking at the clips. This conduit is certainly the most substantial thing in this line that has yet been built, and looks more as if it was intended for every day use than anything of the kind yet laid. It is, in fact, a pole line underground. The poles are short, but they are good insulators. The voltage used is to be only 250 to 300. This, of course, means that four times as much copper will be needed for feed wire as with the 500-volt trolley. The construction is more expensive than the ordinary cable conduit. The fact that the two conductors are directly under the slot and within reach of the small boy with a wire will not conduce to success. The two conductors make a grounded return unnecessary.

### THE ROSE REGISTER.

The very latest in street car fare registers is the "Rose," manufactured by D. L. Bates & Bro., Lima, O., successors to the Lima Register Company. The new register, which has several commendable features, is illustrated herewith, and is the invention of J. H. Rose, who has long been identified with the fare register business. He has patented several, including the Lima dial register, which is also made by the Bates Brothers.

The first feature that attracts the attention of the purchaser is the ease with which it can be changed from one car to another (when necessary). In changing the "out" and "in" signal at the end of the line, the mechanism is automatically locked, so the register can not be operated until the trip register is set to zero.

The totalizer shows a red figure  $\frac{7}{8}$  by  $\frac{3}{4}$  inches, and

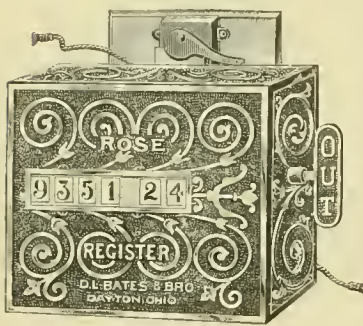

THE ROSE REGISTER.

is not molested in setting the trip register, which shows a black figure of the same size. The change in color obviating any error in taking the statement of the register. The manufacturers claim that it is utterly impossible to manipulate the register dishonestly. The mechanism is simple in construction and positive in action, and it is guaranteed not to get out of order. The case is of handsome design, of polished brass, nickel plate or oxidized copper. There is not a flat spring or gear in its construction, the entire mechanism being on one shaft.

### NICKELS IN THEIR EARS.

A Chinaman boarded a Third avenue New York cable car, and, seating himself in a corner, lapsed into the condition of limp apathy characteristic of his race. His shoulders sloped forward and inward, his head drooped, and his hands rested open-palmed upon his knees. When the conductor came around with his usual salutation of "Fare, please," the Celestial didn't make a move.

"Fare, please," repeated the conductor. "Come, wake up, there."

Solemnly the passenger looked up at the official. Then he put his hand up and scratched his ear meditatively. When he brought it down his fingers clasped a nickel which he handed over to the conductor. The conductor smiled and returned to the platform, but an inquisitive passenger was much mystified as to where the nickel came from. Presently another Oriental boarded the car, and still another, for there are many Chinamen about Chatham Square. The inquisitive passenger watched them closely when the conductor entered, and saw both of them scratch their ears before

paying. He concluded that it must be a superstition and asked the conductor about it.

"Why, they carry their nickels in their ears," said the conductor. "When a Chink starts to go in a car he always sets a nickel in his ear. Perhaps it's for convenience. If it isn't, I don't know why they do it; but they always get the money with a quick movement. It used to puzzle me at first, but I soon got onto them. Now, when a Chink boards my car and falls asleep in the corner, quite a common performance with them, I simply get his fare from the right ear, for that's the one they carry it in."

At this point a Chinaman got on the car, and the inquisitive passenger looked at his right ear. Sure enough, snugly fitted in, was a nickel.

### WAS PERHAPS THE FIRST STREET CAR CONDUCTOR.

George D. Teller, who died recently in Buffalo, N. Y., at the age of 75 years, is believed to have been the first street car conductor in the United States. In 1835 Mr. Teller came from New York City to Buffalo, obtaining employment as conductor on a small road which ran along the terrace and beside the Erie canal to Black Rock. For three years he worked eleven hours every day, for the munificent sum of 75 cents.

Mr. Teller went into mercantile life, where he continued until 1853, when in an indirect way he entered the steam railroad realm by printing bulletin boards. In 1869 he began to publish "Teller's Shippers' and Express Guide." Mr. Teller became active in railroad-ing in 1871, when he was appointed eastern passenger agent of the St. Louis, Kansas City & Northern Railroad, which he held until 1882, leaving to join the Northern Pacific forces as traveling passenger and land agent. He held various responsible positions with this company, retiring from active service two or three years ago.

### NEST EGG FOR EMPLOYEES.

Employees of the New London Street Railway Company, New London, Conn., were agreeably surprised a short time ago by an announcement that the board of directors had deposited in the bank \$13,500 to the credit of each employe. The company had had a profitable and satisfactory year, with few accidents, due to the careful conduct of its employes. So to show its appreciation of good work, this plan was adopted. It is the intention of the company to act in a similar way next year.

A. S. HICKLEY, a superintendent of the Seashore Electric Railway Company, Asbury Park, N. J., received a verdict of \$6,000 against the Indianapolis Street Railway Company, of which he was formerly an official. While getting on the front platform of a car, he was struck in the head by the rebounding of a brake handle.

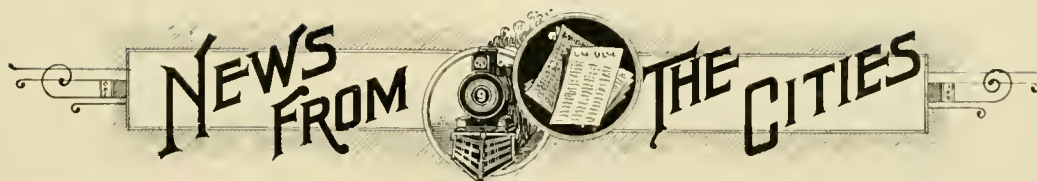

**Alabama.**

BIRMINGHAM, ALA.—The Birmingham Railway and Electric Company is converting its East Lake dummy into an electric line.

**Arkansas.**

PARAGOULD, ARK.—The Paragould Electric Light Company has been chartered with \$5,500 capital by T. H. Wyse and others.

VAN BUREN, ARK.—The Van Buren & Fort Smith Electric Railroad has been mortgaged to George C. Gronely for \$150,000 to provide funds for its construction.

**California.**

SAN FRANCISCO, CAL.—Adolph Sutro will use electricity instead of cable on his new line.

SAN DIEGO, CAL.—The San Diego Electric Street Railway Company will extend its line.

PASADENA, CAL.—The Pasadena & Los Angeles Electric Railway is receiving bids for a power house.

PASADENA, CAL.—L. P. Hansen was the only bidder for the electric railway franchise, and it was awarded to him.

OAKLAND, CAL.—The Haywards Electric Railway has asked for a franchise to change the equipment of the Twelfth street line to electricity.

OAKLAND, CAL.—The receiver of the Piedmont Consolidated Cable Company has been granted permission to equip that portion of the line over Piedmont Hills, with electricity.

LOS ANGELES, CAL.—Work is to be commenced on the Storrs electric crosstown railway, which has been promoted by the Jacksonville, Ill., Railway Company, of which William S. Hook is president.

**Canada**

AYLMER, QUE.—The Hull Electric Railway Company has been given a franchise for an electric line.

ST. THOMAS, CAN.—The St. Thomas Street Railway Company will build an electric line to Port Stanley.

TORONTO, ONT.—The Toronto & Suburban Railway Company has asked for a franchise for an extension.

VANCOUVER, B. C.—It is reported that the electric street railway has been sold to an English company for \$350,000.

HAMILTON, ONT.—The Hamilton & Dundas Railway Company proposes to convert the line into an electric road, if the town will give a bonus of \$25,000.

NIAGARA FALLS, ONT.—A. W. Wright, of Niagara and William Kyle, E. Hewitt and Robert Y. Sexworth contemplate building an electric road from Niagara Falls to Chippewa.

BROCKVILLE, ONT.—The special committee of the city council to consider the electric railway project made a favorable report, recommending that the company be relieved from taxation for ten years.

MONTREAL, QUE.—Frost loosened the iron girders of the new office building of the City Passenger Railway. The top floor fell through the building carrying everything with it. Two men were killed.

OTTAWA, CAN.—It is reported that the Canadian Pacific Railroad Company and the Ottawa Electric Railway Company have combined in a movement to build an electric line to Aylmer via Hintonburgh, Skead's Mills and Britannia.

HAMILTON, ONT.—Messrs. Biggs and Lewis, of Toronto, are endeavoring to organize the Toronto, Hamilton & Niagara Falls Electric Railway Company, to build an electric line from Toronto to Hamilton, and thence to a point on Niagara river, with a branch from Grimsby to Smithville and Dunnville.

**Chicago.**

CHICAGO.—The Wells & French Car Company's street car department was burned November 15.

CHICAGO.—The Chicago City Railway Company will issue \$1,000,000 additional stock July 1, 1895.

CHICAGO.—The South Chicago City Railway Company has applied for franchises on various streets.

CHICAGO.—The North Side Electric Company has filed its certificate for a proposed increase of its capital stock to \$1,000,000.

CHICAGO.—The Chicago General Railway Company will issue \$10,000,000 in first mortgage 6 per cent bonds.

CHICAGO, ILL.—The Chicago General Street Railway Company has asked the city for franchises on many miles of streets.

CHICAGO.—The Nutting Electric Company, has been incorporated with \$50,000 capital, by James W. Hedenburg, Carl McFadden, Frank A. Smith.

CHICAGO.—The Metropolitan Elevated stockholders voted to construct twenty-five miles of additional roadway, estimated to cost about \$20,000,000.

CHICAGO.—The Interurban Railroad Company has been incorporated with \$50,000 capital by John W. Harrington, 134 Washington street; John Dymonde, 115 La Salle street; and Edgar H. Thorpe.

CHICAGO.—The Metropolitan West Side Elevated Railroad Company has filed articles with the secretary of state setting forth an enlargement of the objects of the corporation. This action enables it to make the extensions voted recently.

CHICAGO.—The Great Western Manufacturing Company, electrical supplies, with factory at Duluth, Minn., is in financial difficulty. The First National Bank, Chicago, is in possession of all the property on a claim of over \$100,000. It is too soon to know what the creditors will get.

CHICAGO.—The Union Elevated Railroad Company, \$5,000,000 capital, and the Central Chicago Elevated Railroad Company, with \$3,000,000 capital, have been incorporated to build down town loops for the elevated roads. The former is a part of the Yerkes' syndicate, and the latter is a union of the Metropolitan and Alley L interests, as John Worthy and Marcellus Hopkins both appear among the incorporators.

**Connecticut.**

NORWICH, CONN.—The Norwich Street Railway Company will make extensions.

BRISTOL, CONN.—The Bristol & Plainville Tramway Company will extend its line.

STAMFORD, CONN.—The Stamford Street Railway Company will be changed to an electric line. Some T rail will be used.

WESTPORT, CONN.—Local business men want to build a line to Southport to connect with the Bridgeport Traction Company.

BRIDGEPORT, CONN.—McMahon & Wrenn are surveying for five miles of electric road, in connection with their electric light plant at Pleasure Beach.

WESTPORT, CONN.—Francis W. Marsh, Bridgeport; Charles Fable, F. D. Ruland, M. D., W. E. Osborne, Charles Harris, Westport, will build an electric line from Weston to Westport.

NEW HAVEN, CONN.—Mayor Sargent is working on a plan for the extension of the New Haven Street Railway Company to East Rock Park. Application will be made to the legislature, so that work will begin in the spring.

### District of Columbia.

WASHINGTON, D. C.—The Glen Echo Railroad Company will extend its lines.

WASHINGTON, D. C.—The Columbia Street Railway Company will build a \$30,000 brick office building and car shed at Rosedale.

### Florida.

PALATKA, FLA.—The Palatka & Heights Street Railway Company will extend its line and use T rail.

PALATKA, FLA.—E. C. Haskell, William R. Powell and R. Packer have an ordinance for an electric line before the council.

ST. AUGUSTINE, FLA.—E. M. Holmes, president of the St. Augustine Electric Street Railway Company, has given notice to the city council that track laying will begin.

### Georgia.

COLUMBUS, GA.—Drake & Stratton, contractors, are reconstructing the Columbus Railroad Company's horse and dummy lines for electric power.

COLUMBUS, GA.—The Columbus Railroad Company and the North Highland Electric Railroad Company have consolidated. The officers are: John F. Flournoy, president; E. J. Rankin, vice president; Rhodes B. Bowne, secretary.

### Illinois.

ALTON, ILL.—The Alton Electric Street Railway Company will make improvements.

OTTAWA, ILL.—The Ottawa Electric Street Railway Company will make extensions in the spring.

DIXON, ILL.—The Rock River Electric Railway Company wants to extend its line to Grand Detour.

STERLING, ILL.—The Sterling Street Railway Company has been sold at sheriff's sale to satisfy a judgment of \$2,000.

EAST ST. LOUIS, ILL.—The car shed of the East St. Louis Electric Railway Company and seventeen cars were burned.

FREEPORT, ILL.—The Freeport Street Railway Company is now a full fledged electric line, having been opened for traffic Thanksgiving Day.

LINCOLN, ILL.—The Lincoln Electric Street Railway Company has had its franchise renewed and has been given additional grants of right of way.

LA SALLE, ILL.—A. G. Davids, superintendent of the City Electric Railway, wants figures on five equipments of canvas vestibule for front platform.

SAVANNAH, ILL.—J. B. Canterbury, La Crosse, Wis., is figuring on building an electric line. T rail will be used. A. D. Appleby is the local promoter.

WHITEHALL, ILL.—The Whitehall Electric Company has been incorporated with \$10,000 capital, by Golbert S. Vasseller, Orlando F. Guiswold and Henry W. Hand.

WAUKEGAN, ILL.—The Board of Trade at a recent meeting received favorable reports from the Bluff City Electric Street Railway Company, indicating that work may soon begin.

WAUKEGAN, ILL.—The Bluff City Electric Railway Company has completed its organization with these officers: Homer Cooke, president; T. H. Lindsay, treasurer; S. D. Talcott, secretary. The capital stock is \$200,000. The president's office is Room 50 Borden Block, Chicago.

### Indiana.

ANDERSON, IND.—The street railway will be extended to Collingwood and East Lynne.

ELKHART, IND.—The Indiana Electric Railway Company's line has been opened to traffic.

GREENFIELD, IND.—A petition has been filed for a receiver for the Greenfield Electric Light & Power Company.

ANDERSON, IND.—The Anderson Electric Street Railway Company has bought thirty-three acres of land for a park.

SEYMOUR, IND.—John S. Crump, Columbus, is reported to be negotiating for the purchase of the Seymour Street Railway.

MARION, IND.—The Marion City Railway Company is contemplating improvements, and may build a power house to accommodate additional machinery.

CRAWFORDSVILLE, IND.—C. E. Loss & Co., Chicago, have secured the contract for constructing and equipping the Indianapolis, Anderson, Alexandria & Marion Electric Railway for \$525,000.

TERRE HAUTE.—Voters of Harrison township will, on Dec. 17, vote on the proposition to donate \$20,000 to the Terre Haute & Brazil Electric Railway Company, which proposes to build to Brazil. Max Joseph is president of the company.

INDIANAPOLIS, IND.—The Indianapolis, Greenwood & Franklin Electric Railway Company, recently reorganized and incorporated, has asked for a franchise in Marion County. Grafton Johnson and J. K. Polk are the principal stockholders.

INDIANAPOLIS, IND.—H. Sellers McKee, president of the Citizens' Street Railroad has instructed the local management to complete improvements that have been waiting for the court decision. One new line will be built, and sixty new cars purchased.

### Iowa.

OTTUMWA, IA.—The Ottumwa Electric Railway Company will make extensions.

SIoux CITY, IA.—E. L. Kirk has been appointed receiver for the Riverside road.

FT. DODGE, IA.—S. T. Meservey and others who have bought the street railway will equip it with electricity.

SIoux CITY, IA.—The Manhattan Trust Company, New York, trustee for \$300,000 of bonds, has applied for a receiver for the Sioux City Cable Railway Company.

DUBUQUE, IA.—John Balch, Boston, has been appointed receiver of the Dubuque Light & Traction Company on application of the Old Colony Trust Company, Boston, trustee of a first mortgage to secure \$385,000 of bonds.



## Kansas.

LEAVENWORTH, KAS.—The Leavenworth Electric Railway Company will extend its lines.

SALINA, KAN.—L. M. Erb, Leavenworth, has been granted the street railway and electric light franchise. Five miles of the former must be completed within four months.

## Kentucky.

BOWLING GREEN, KY.—M. H. Crump, C. E., wants prices on electric street railway equipment.

ASHLAND, KY.—The Ashland & Catlettsburg Street Railway Company has secured its right of way and will build.

LEXINGTON, KY.—The Lexington Passenger & Belt Railway Company has been sold to the Chesapeake & Ohio Railroad Company for \$175,000.

NEWPORT, KY.—The South Covington & Cincinnati Street Railway Company will put in an electric system on Fifth street and a double track on Central avenue.

COVINGTON, KY.—The South Covington & Cincinnati Street Car Company, which purchased the franchise of Cincinnati & Rosedale Company, has been given an ordinance. The company intends to make other extensions during the spring.

HENDERSON, KY.—The Henderson Electric Street Railway Company has been reorganized with the following: W. E. Whitney, president; J. N. Alsop, secretary; David Banks, Reuben A. Miller and Elijah Sebree, directors. The company will spend \$50,000 in improvements. Eight motor cars and nine trailers are wanted.

## Louisiana.

NEW ORLEANS, LA.—The New Orleans Traction Company has decided to have an independent power plant.

NEW ORLEANS, LA.—President McClellan, of the St. Charles Street Railroad Company, has returned from an inspection trip, and plans are being made for converting the line into an electric road.

NEW ORLEANS, LA.—The New Orleans Traction Company has made financial arrangements which will enable it to equip all its lines with electricity, including twenty miles of new franchises.

NEW ORLEANS, LA.—It is reported that the Jefferson Avenue Railway Company will build its ten miles of double track as soon as right of way is secured. W. N. Louque, 835 Canal street, is in charge.

NEW ORLEANS, LA.—The Jefferson Avenue Railway Company has asked for a franchise for an electric line to Kennerville.

NEW ORLEANS, LA.—B. T. Woods has asked for a franchise for a double track horse railway from Carrollton to Southport, with privilege of changing to an electric line.

## Maine.

NORWAY, ME.—The directors of the proposed line to Paris are, J. Manchester Haynes, Orville D. Baker, John F. Hill, George Macomber, Augusta; George L. Beal, Freehand Howe, Norway; Herbert L. Shepherd, Rockport.

LEWISTON, ME.—The Norway & Paris Street Railway Company has been incorporated with \$25,000 capital, to build two miles of electric road by George L. Beal and Freehand Howe, Norway; John F. Hill, Augusta; Herbert L. Shepherd, Rockport; George E. Macomber, Augusta.

PORTLAND, ME.—The Portland & Yarmouth Electric Railway Company has been incorporated with \$200,000 capital; Edward S. Perry, New Haven, Conn., president; James O. Mayo, Naugatuck, Conn., vice-president; John S. Bradley, New Haven, Conn., treasurer. Work will be begun at once.

## Maryland.

BALTIMORE, MD.—The City and Suburban Railway Company will build an electric line to Clifton.

ANNAPOLIS, MD.—Surveying will begin for the line of the Annapolis & Bay Ridge Electric Railway Company.

KENSINGTON, MD.—The Chevy Chase & Kensington Electric Railway Company has been given a franchise.

BALTIMORE, MD.—The Mt. Washington Electric Railway Company has asked the county commissioners for a franchise for two miles of track.

CRISFIELD, MD.—T. S. Hodson is president, and O. P. Byrd, secretary, of a company formed to build two and a half miles of electric line to carry oysters.

BALTIMORE, MD.—Thomas S. Hodson, president of the Electric Light & Railway Company of Somerset county, says work will be begun in the spring.

BALTIMORE, MD.—The Clifton Park Street Railway Company has been organized, to build a suburban line. Winfield J. Taylor and E. B. Hunting are interested.

BALTIMORE, MD.—Nearly all the grading for the Baltimore, Middle River & Sparrows Point Electric Railway Company has been finished. Cars will be running by February.

BALTIMORE, MD.—The Randallstown, Harrisonville & Granite Rapid Transit Company has been granted six months to begin work on its line from Pikesville to Harrisonville.

HAGERSTOWN, MD.—H. A. Riddle, general passenger agent of the Cumberland Valley Railroad, is authority for the statement that the line from Harrisburg to Dillsburg will be converted into an electric line.

BALTIMORE, MD.—The Mt. Washington Electric Railway Company has been incorporated with \$150,000 capital by George R. Webb, William G. Webb, Charles W. Hatter, Oscar C. Martenet and John W. Middendorf.

BALTIMORE, MD.—The Wittington Electric Car Heating Company has been incorporated, with \$100,000 capital, by Percy B. McLaren, Alexander Brown, Henry W. Williams, Frank D. Torre and G. H. Whittington.

BALTIMORE, MD.—The Pikesville, Reisterstown & Emory Grove Railroad has asked the county commissioners for a permit to lay tracks between Mt. Washington and Park Heights. It will connect with the traction company.

CUMBERLAND, MD.—The Cumberland Passenger Railway Company has organized, with the following: W. E. Walsh, chairman; W. D. Paisley, secretary and treasurer; D. J. Blackiston, J. H. Holzshu and F. B. Beall, trustees. A line will be built.

BALTIMORE, MD.—The Baltimore, Severn Park & Annapolis Electric Railway Company is being organized with \$250,000 capital by Thomas C. Musgrove, Philadelphia; Benjamin F. Simons, Henry Y. Brady, G. Howard White and David S. Collett, Baltimore.

BALTIMORE, MD.—Work has begun on the Washington & Baltimore Electric Railroad, on the section between Laurel and Washington. When the road is completed, fare between the cities will be \$1.00 instead of \$2.40, round trip. David M. Newbold is president.

## Massachusetts.

WORCESTER, MASS.—The North End Street Railway Company will extend its lines.

SPRINGFIELD, MASS.—The Springfield Street Railway Company has been given permits to extend its tracks.

**NORTH ADAMS, MASS.**—The Hoosac Valley Street Railway Company will build an electric line to Williamstown.

**LYNN, MASS.**—The Lynn & Boston Street Railway Company will build next spring a line from Peabody to Boston.

**WESTFIELD, MASS.**—It is probable that J. A. Crane will secure control of the Woronoco Company and make extensions.

**COLERAINE, MASS.**—C. A. Marcy, J. B. Clark and Arthur A. Smith are interested in a project to build a line to Shelburne Falls.

**HOPKINTON, MASS.**—The Hopkinton, Woodville & Westboro Street Railway Company has been incorporated, with \$50,000 capital.

**BRAINTREE, MASS.**—The Braintree & Weymouth Street Railway Company has accepted its franchise and will build four miles of road.

**NORTHAMPTON, MASS.**—The Northampton Electric Railway Company will begin work at once on its \$100,000 extension of five miles to East Hampton.

**NEW BEDFORD, MASS.**—The Dartmouth & Westport Street Railway Company has increased its capital stock to \$150,000, and will also issue \$150,000 bonds.

**MARLBORO, MASS.**—The Marlboro & Westboro Street Railway Company wants a franchise for six miles of track. Dr. E. B. Harvey, Westboro, is president.

**FALL RIVER, MASS.**—Surveys have begun for the Fall River & Providence Electric Railroad project, which will take in Swanzey village and Barneyville.

**NEW BEDFORD, MASS.**—The Union Street Railway Company has been granted a perpetual franchise in Fairhaven. An electric extension will be made at once.

**WORCESTER, MASS.**—The Worcester, Leicester & Spencer and the Worcester & Millbury Street Railway Companies have been consolidated with \$620,000 capital stock.

**HOLYOKE, MASS.**—The Holyoke Street Railway Company has been granted a franchise from Willimansett to Chicopee Falls. A bridge will be built. Several local franchises have also been granted.

**SPRINGFIELD, MASS.**—The Springfield Street Railway Company will petition the railroad commissioners for permission to increase its capital to \$1,250,000, in order to build a power house and make extensions.

**FALL RIVER, MASS.**—The Fall River Street Railway Company has been incorporated with \$50,000 capital by Wendell E. Turner, J. Frank Shove, James E. Osborn and others. It is proposed to begin work this season.

### Michigan.

**DETROIT, MICH.**—The Pack-Everett syndicate has been granted its ordinance.

**SAGINAW, MICH.**—The Union Street Railway Company will build a \$50,000 power house and change the equipment of the horse line to electricity.

**SAGINAW, MICH.**—The ordinance for the proposed line to Bay City, in which Walter S. Eddy, Ottawa, Ont., is the principal, has been passed to the second reading.

**SAGINAW, MICH.**—The Bay City & Saginaw Street Railway Company has been given a franchise to the Bay City limits. An ordinance is pending for franchises in the latter city.

**MACKINAW, MICH.**—J. H. Roberts, of Grand Rapids, has secured a franchise for an electric road around Mackinac Island. It will be completed by July 1, 1895. Electric lighting will also be done.

**SAGINAW, MICH.**—The Union Street Railway Company has bought the City of Saginaw railroad and will change the equipment to electric. All the street car lines of the city are controlled by a Detroit syndicate.

**TRAVERSE CITY, MICH.**—The Traverse City, Peninsula & Old Mission Electric Railway Company has been incorporated, with \$160,000 capital, by J. G. Ramsdell, L. K. Gibbs, and others. It will carry both freight and passengers.

**DETROIT, MICH.**—E. H. Everett, Cleveland, and Albert and Green Pack, Alpena, Mich., have petitioned the city council for several street railway electric franchises. The proposed lines will be parallel with many of the lines already in operation, and fare will be three cents.

**DETROIT, MICH.**—Robert Müller, general superintendent of the Michigan Central Railroad, writes, "I am unable to find that the management of the Michigan Central road has any information that the statement that the line between Buffalo and Toledo via Detroit is to be converted into an electric line."

### Minnesota.

**DULUTH, MINN.**—The Duluth Street Railway Company lost a car barn by fire.

### Missouri.

**KANSAS CITY, MO.**—The Northeast Railway Company will be sold to pay bonds issued in 1889.

**KANSAS CITY, MO.**—The car house of the Northeast Street Railway Company was burned. Loss, \$20,000.

**KANSAS CITY, MO.**—The Kansas City Cable Railway Company, will use electricity on its Rosedale avenue line.

**JOPLIN, MO.**—F. H. Fitch has deposited \$3,000 and accepted the electric road ordinance. Citizens have raised \$15,000.

**ST. LOUIS, MO.**—The Carthage, Webb City, Joplin & Galena Electric Railway Company has been incorporated, with \$175,000 capital.

**CHILlicothe, MO.**—The receiver of the Chillicothe Street Railway Company has been discharged, and the company is in possession of its own.

**KANSAS CITY, MO.**—Property owners are circulating a petition for changing the Metropolitan Company's Broadway line into an electric line.

**CARTHAGE, MO.**—The Jasper County Electric Railway Company has been incorporated, with \$50,000 capital, by John W. Halliburton, Samuel Reynolds, Isaac Perkins, and others.

**CAPE GIRARDEAU, MO.**—Gambon Bros. have bought the Home Electric Light Plant of Hartsell & Son. They will put in a 1,000-light incandescent and a 50-light arc machine.

**ST. JOSEPH, MO.**—Manager Van Brunt of the St. Joseph Traction & Lighting Company, says it is probable that the line will be extended to St. George and Lake Contrary next spring.

**KANSAS CITY, MO.**—It is reported that Robert Fleming, of the Kansas City Cable road, has bought a large interest in the West Side Electric road, which places both systems under one control.

**SEDALIA, MO.**—The Sedalia & Brown Springs Electric Railway Company has been incorporated with \$80,000 capital by D. C. Mesker W. E. and M. E. Sterne, Charles Carroll and D. F. Webster.

**ST. LOUIS, MO.**—J. E. Young, Chicago, and others, are interested in the Midsuburban Railway Company, which intends to build an electric road from Maplewood Park to connect with the Lindell Railway Company's system.

**ST. LOUIS, MO.**—The Fourth Street & Arsenal Railway, which has been out of commission for two years, will be operated as an electric line. The Fruin-Bainbrick Construction Company has the contract for constructing the line, and power will be rented from the Edison Illuminating Company. It is the intention, ultimately, to extend eighteen miles, when a power house will be built. Charles Green is president.

## New Hampshire.

MANCHESTER, N. H.—The Board of Trade is working hard for an electric line.

NASHUA, N. H.—The Nashua Street Railway Company has received permission to equip all of its standard gage lines with electricity.

## New Jersey.

RAHWAY, N. J.—The Rahway Horse Railroad Company wants to equip its line with electricity.

PATERSON, N. J.—The Paterson, Passaic & Rutherford Railway Company will extend its lines.

NEWARK, N. J.—The Suburban Traction Company has made an offer of fifty cents to its creditors.

WOODBURY, N. J.—The Camden, Gloucester & Woodbury Electric Railway Company has been given a franchise.

NEWARK, N. J.—The Consolidated Traction Company will build a power house between Newark and Jersey City.

CAMDEN, N. J.—The Camden Horse Railroad Company will extend its tracks to West Collingswood and Bettlewood.

TRENTON, N. J.—General Manager Gaddis, of the Philadelphia & New York Traction Company, says that construction will soon begin.

RUTHERFORD, N. J.—The Newark, Rutherford & Hackensack Electric Railway Company has been absorbed by the Union Traction Company.

PATERSON, N. J.—The stockholders of the Bergen Turnpike Company voted bonds for building an electric line from Hackensack to Hoboken.

NEWARK, N. J.—Watson Whittlesey has been appointed agent of the bondholders of the Suburban Traction Company to effect an arrangement with creditors.

ELIZABETH, N. J.—Frederick L. Heidritter et al, have asked for a receiver for the J. W. Fowler Car Company. The hearing will be December 6, at Newark, N. J.

CAMDEN, N. J.—The court of errors and appeals has reversed the decision of the supreme court, declaring illegal three ordinances of the Camden Horse Railroad Company.

RAHWAY, N. J.—The New York & New Jersey Traction Company has applied for a franchise to connect Westfield, Clark township, Rahway and Elizabeth by an electric line.

CAMDEN, N. J.—The Jamaica Construction Company has been incorporated with \$10,000 capital to build electric railways, by Edward Hsley and Walter C. Smith, Philadelphia, and John McNeil, Haddonfield.

NEWARK, N. J.—The ordinance passed by the board of works, July 13, 1893, giving ten franchises to the Consolidated Traction Company, has been decided invalid by the supreme court of New Jersey, on the ground that the ordinance did not specify the location of the tracks.

RUTHERFORD, N. J.—The Union Traction Company has been incorporated with \$1,500,000 capital to build trolley roads in Bergen county. The officers are George H. Forbush, Brookline, Mass., president; Henry G. Bell, Rutherford, N. J., vice president; Henry C. Ellis, Brookline, secretary; F. J. Cellanen, Rutherford, treasurer.

ASBURY PARK, N. J.—The ordinance granted by the council of Neptune City to the Asbury Park & Belmar Street Railway Company, has been decided illegal by the supreme court of New Jersey, because a majority of property owners along the line had not given their consent. The company will carry the case to the court of errors and appeals.

## New York.

OSWEGO, N. Y.—The Oswego Street Railroad Company will build extensions.

SENECA FALLS, N. Y.—The Seneca Electric Railway Company will extend its line.

ONEONTA, N. Y.—The Oneonta Street Railway Company may change to electric.

ORISKANY, N. Y.—Committees are at work on subscriptions to build a car line to Whitesboro.

WEST NEW BRIGHTON, N. Y.—The Midland Railway Company will equip its line with electricity.

TROY, N. Y.—The Troy City Railway Company will abolish the bell punch and adopt fare registers.

WAVERLY, N. Y.—The Waverly, Sayre & Athens Street Railway Company will be completed to Athens.

MECHANICVILLE, N. Y.—Powers Bros., Lansingburgh, have the franchise for an electric road to Stillwater.

BROOKLYN, N. Y.—The Brooklyn City Railroad Company has received permission to extend its line to Flushing.

BATAVIA, N. Y.—The New York Construction Company, New York City, has asked for a franchise for an electric road.

STEINWAY, L. I.—The Newtown Railway Company has secured its franchises in Newton, Flushing and Long Island City.

GLEN FALLS, N. Y.—It is reported that the Otis Elevator Company, New York, will build a cable road to the top of Mt. Ferguson.

KINGSTON, N. Y.—The line of the Colonial Railroad Company will be completed as \$27,000 has been raised from receiver's certificates.

ISLIP, N. Y.—The Electric Construction Company, New York, has applied for a franchise for an electric line from Brentwood to Bay Shore.

STATEN ISLAND, N. Y.—The Prohibition Park Electric Railway Company will be extended and united with the Midland Railway Company.

BUFFALO, N. Y.—The Crosstown Street Railroad Company has filed with the secretary of state a statement of the proposed extension of its lines.

GREENFIELD, N. Y.—The Ballston Electric Railway has applied for a franchise to Milton, Middle Grove, Page's Corners, to Darrow's Station.

SYRACUSE, N. Y.—The Syracuse & East Side Railway Company has given a mortgage of \$250,000 to the West End Trust & Safe Deposit Company.

OGDENSBURG, N. Y.—The Ogdensburg Street Railway Company has applied for electric railway franchises in the towns of Lisbon and Oswegatchie.

BROOKLYN, N. Y.—The State Railroad Commissioners have granted permission to the Nassau Electric Railroad Company to use the overhead system.

BROOKLYN, N. Y.—Under the direction of Charles Brown, receiver, \$50,000 will be expended in extensions of the Flushing & College Point Electric Railroad Company.

NIAGARA FALLS, N. Y.—Consents have been secured for the proposed electric line around Grand Island. John J. McIntire, the promoter, says work may begin in the spring.

BROOKLYN, N. Y.—The Coney Island & Brooklyn Railroad Company will equip its Franklin avenue line with electricity. The city will pay \$10,000 for the tracks and franchise on Hamilton avenue.

PEEKSKILL, N. Y.—The Peekskill, State Camp & Mohegan Railroad Company, incorporated recently with \$10,000 capital, has been granted a franchise in spite of the strenuous opposition of all the preachers.

SCHENECTADY, N. Y.—The United States district court has decreed that all the property of the Schenectady Street Railway Company shall be sold January 3, 1895, to satisfy the claim of the Central Brush Company, New York.

GENEVA, N. Y.—The Waterloo, Seneca Falls & Cayuga Lake Railway Company has been incorporated with \$150,000 capital by Thomas Craig, Trenton, N. J.; Charles E. W. Smith, New York; Mark T. Atchley, Seneca Falls.

NEW YORK CITY.—The people voted \$50,000,000 for an underground electric line from one end of Manhattan Island to the other. Work must begin within thirty days after official notice to the Rapid Transit Commissioners of the result of the election.

NEW YORK, N. Y.—The Prohibition Park & Port Richmond Trolley Company and the Midland Railway Company, Staten Island, have been consolidated. Electricity will be adopted and extensions made. Negotiations are being made for franchise for eight miles of road.

SENECA FALLS, N. Y.—It is reported that the Seneca Electric Railway Company and the Geneva & Waterloo Railroad Company will be consolidated. The latter company has secured a franchise in Waterloo. Thomas Craig, New York City, owner of Cayuga Lake Park, is the principal stockholder.

WATKINS, N. Y.—The Watkins & Havana Railroad Company has been incorporated with \$50,000 capital by W. H. Wait, O. P. Hurd, L. H. Durland, C. S. Frost, Watkins; John E. Mulford, Dr. C. D. Clutson, Havana. An electric road will be built from Watkins to Havana, and ultimately extended to Horseheads and Elmira.

CORNING, N. Y.—The Corning & Painted Post Street Railway Company has been incorporated with \$100,000 capital, to construct five miles of electric road, by Edward M. Shedd, William H. Tyles, Worcester, Mass.; H. A. Clark, L. B. Tylee, Frank H. Viele, John L. Miller, Edwin J. Carpenter, Morris L. Gregory, Corning, and John W. Clark, Waverly.

### Ohio.

LIMA, O.—W. J. Ritchie has petitioned for a franchise for an electric line.

TOLEDO, O.—J. W. Caldwell is securing right of way for an electric line to Sylvania.

CLEVELAND, O.—The Cleveland City Railway Company will make a four mile extension.

SPRINGFIELD, O.—Surveyors are in the field for an electric line to Jamestown, Green county.

TOLEDO, O.—The Toledo, Maumee & Perrysburg Electric Railway Company will build a bridge.

CLEVELAND, O.—The Akron, Bedford & Cleveland Electric Railway Company has secured right of way.

LIMA, O.—Preparations have been completed and contracts let for grading the Wayne street electric road.

NILES, O.—The Trumbull Electric Company has applied for a franchise to build an electric line to Girard.

HARTWELL, O.—The New York Standard Construction Company has asked for an electric road franchise.

MARIETTA, O.—The Marietta Street Railway Company has applied for an electric franchise and extensions.

CLEVELAND, O.—A. W. Buel has the contract for the Cuyahoga Suburban Railway Company to Randall.

NILES, O.—D. Moynahan, owner of the Mineral Ridge & Niles Electric Railroad, will extend his line to Girard.

AKRON, O.—The Seiberling Company has secured a franchise for an electric line to Kent. Construction will soon begin.

TOLEDO, O.—An ordinance has been passed requiring street railway companies to equip cars with headlights and fenders.

MT. VERNON, O.—The Mt. Vernon & Wauhatchie Electric Railway Company has been incorporated with \$50,000 capital.

TOLEDO, O.—The Toledo & Maumee Valley Electric Railway Company will extend its line from Maumee to Waterville.

CINCINNATI, O.—The Cincinnati Street Railway Company will extend its Clark street and its Avondale electric lines.

YOUNGSTOWN, O.—The Youngstown Street Railway Company has asked a franchise for an electric railroad on Mill street.

WEST UNION, O.—The electric railway which was to have connected Manchester, West Union and Winchester, is abandoned.

CHAGRIN FALLS, O.—The Newburgh township trustees have granted a franchise to the Suburban Electric Railway Company.

FOSTORIA, O.—An ordinance has been passed reviving the franchise of the Tiffin & Fostoria Electric Street Railway Company.

CINCINNATI, O.—The Cincinnati Street Railway Company will remodel its Spring Grove avenue barns at a cost of \$14,000.

WELLSTON, O.—The Wellston Street Railway Company has changed its name to the Wellston & Jackson Belt Railroad Company.

CINCINNATI, O.—The Cincinnati Street Railway Company will build an iron and brick power house 189x146 feet at Cumminsville.

AKRON, O.—Thomas F. Walsh has been given a franchise for an electric line to the Portage county line, and will extend it to Kent.

TOLEDO, O.—The Toledo Consolidated and the Toledo Electric Street Railway companies have been granted franchises for extensions to Bay View Park.

AKRON, O.—Local capitalists are organizing to build a line to Canton by way of East Akron, Krumroy, Greentown, Union Town and New Berlin.

BUCYRUS, O.—John F. Barry, New York; C. H. Read, O. P. Curran, Jr., and C. G. Hussey, Pittsburg, have petitioned for a franchise for an electric road to Galion.

WINCHESTER, O.—Frank E. Holliday has sold his interest in the Manchester & Northern Railroad Company to the Highland Construction Company, Chicago.

NEW BREMEN, O.—The city council has given a franchise for an electric line to James B. White, Ft. Wayne, Ind., who is obtaining a route for an interurban road.

YOUNGSTOWN, O.—A. A. Anderson, manager of the Youngstown Street Railway, has applied to the county commissioners for franchises to Warren, Niles and Girard.

TIFFIN, O.—B. L. Cook, Chicago, and Major Turner, New York, are reported to have negotiated the sale of the Tiffin Consolidated & Interurban Railway Company to eastern capitalists.

SPRINGFIELD, O.—The Springfield Railway Company will spend \$35,000 to \$40,000 on tracks; \$10,000 additional power; \$10,000 new cars, and \$15,000 on extensions and improvements.

**MANSFIELD, O.**—It is reported that the Big Four Railroad will build an electric line from Wellington to Galion, touching Mansfield and other towns, to be operated as a feeder for the main line.

**CLEVELAND, O.**—Martin A. Dodge, says the Euclid Avenue & Lockwood Railway Company will be extended to Chardon, Burton and Mantua, connecting with the Akron Electric Railway Company.

**RAVENNA, O.**—The Ravenna Street Railway & Power Company has been incorporated, with \$50,000 capital by G. H. Worthington, W. J. Akers, and G. W. Gardner, Cleveland, and J. H. Evans and R. B. Carnahan, Ravenna.

**CLEVELAND, O.**—The Cleveland & Elyria Electric Railroad Company has been incorporated with \$200,000 capital by F. T. Pomeroy, M. A. Sprague, A. W. Bishop, C. W. D. Miller, Leon M. Coe, William Christy and A. H. Pomeroy.

**WARREN, O.**—The Mahoning Valley Electric Railway Company has been incorporated with \$150,000 capital by C. F. Clapp, Warren; R. G. Sykes, Niles; G. E. Herrick and Andrew Squires, Cleveland; Arthur A. Anderson and John E. McVey, Youngstown.

**NILES, O.**—The officers of the Mahoning Valley Street Railway Company are C. F. Clapp, Warren, president; R. G. Sykes, Niles, vice president; John E. McVey, Niles, secretary; A. A. Anderson, treasurer. The company expects to soon start work on a line to Youngstown.

**ELYRIA, O.**—Judge Steele, Albert H. Johnson and W. B. Bedortha Oberlin; W. B. Thompson, Lorain; C. A. Metcalf, A. R. Webber, Hon. W. A. Braman and Parks Foster, Elyria, are organizing a company with \$100,000 capital to build an electric line from Oberlin to Elyria.

**FRONTON, O.**—Frank C. Holliday is at the head of a company which will build a line from Pomeroy to Middleport, O. He is in the market for 600 tons 50-pound relaying rail and fastenings, three second-hand motor cars and trailers, and second-hand power house equipment, for spring delivery.

## Oregon.

**PORTLAND, ORE.**—An effort is being made to consolidate the three street railroad companies.

## Pennsylvania.

**LYKENS, PA.**—A franchise has been granted for an electric line to Reiner City.

**MCKEESPORT, PA.**—The Versailles Traction Company will extend its line to Buena Vista.

**GETTYSBURG, PA.**—The Gettysburg Electric Street Railway Company will extend its lines.

**POTTSVILLE, PA.**—The Schuylkill Electric Railway Company will build a \$100,000 power house.

**READING, PA.**—An electric road has been projected to Manheim, via Rothsville, Akron and Ephrata.

**EAST GREENVILLE, PA.**—Application has been made for a charter for an electric road to Spring House.

**PHILIPSBURG, PA.**—The Electric Street Railway Company is about to build a power house and car barns.

**PHILADELPHIA, PA.**—The Delaware & Schuylkill Traction Company will build a power house at Tabor station.

**WILLIAMSPORT, PA.**—The South Williamsport Passenger Railway Company will extend its line to Duboistown.

**CHAMBERSBURG, PA.**—Capitalists have offered to build an electric line if citizens will subscribe for \$20,000 of stock.

**MCKEESPORT, PA.**—The McKeesport & Braddock Railway Company has asked for a franchise between these cities.

**MORRISTOWN, PA.**—The People's Traction Company, Philadelphia, has bought the Perkiomen & Reading turnpike.

**BRIDGEPORT, PA.**—The town council has given a franchise to the Philadelphia & Rosemont Electric Railway Company.

**PITTSBURG, PA.**—The electric railway company which is building from Pittsburg to Carnegie will extend its tracks to Leasdale.

**POTTSVILLE, PA.**—The Pottsville & Reading Electric Railway Company has been granted right of way through Schuylkill Haven.

**PITTSBURG, PA.**—The Allegheny, Etna & Sharpsburg Electric Street Railway Company will make extensions, and is building two bridges.

**PITTSBURG, PA.**—The Pittsburg & Arlington Avenue Street Railway Company has applied for an ordinance for an extension on several streets.

**ERIE, PA.**—John Hallock, Detroit, has been looking over the ground between this point and Cambridge, with a view to building an electric line.

**PITTSBURG, PA.**—The barns of the Allegheny Traction Company, 49 horses, seven horse cars and seven electric cars were burned. Loss, \$75,000.

**TOWER CITY, PA.**—The Williams Valley Electric Railway Company has secured franchises from Williamstown and Lykens, and has one pending here.

**PITTSBURG, PA.**—The Allegheny, Etna & Sharpsburg Company have resumed operations on an abandoned horse line, which will be changed to electric.

**BRADDOCK, PA.**—The Braddock Electric Street Railway Company will relay its tracks in Braddock township, which were covered up by the town two years ago.

**PHILADELPHIA, PA.**—The Twenty-second Street and Allegheny Avenue Passenger Railway Company, will apply for franchises and construct lines on several streets.

**ALLENTOWN, PA.**—The Lehigh Valley Traction Company has been given franchises for a belt line through Griesemerville, Wescolville, Mountainville and Aineyville.

**POTTSVILLE, PA.**—The city council of St. Clair has repealed the Pottsville Traction Company ordinance and granted a franchise to the Tamaqua & Pottsville Company.

**PHILADELPHIA, PA.**—The Suburban Passenger Railway Company and its lessee, the Philadelphia Traction Company, have been granted franchises over ninety-one miles of streets.

**WIKESBARRE, PA.**—General Manager Graham, of the Wyoming Valley Traction Company, says that work will soon begin on the new line. Several car loads of rails have been received.

**LANSDALE, PA.**—The Philadelphia & Lansdale Railway Company has been incorporated, with \$100,000 capital, to build sixteen miles of electric road. Robert A. Welch, Philadelphia, is president.

**WILLIAMSPORT, PA.**—Peter Voneida, Samuel Pfeegor, S. C. Tate, J. V. Ramsey, Leonard Wright and J. H. Pearson, of Nippenose Valley, are collecting subscriptions for an electric line to Jersey Shore.

**LANCASTER, PA.**—The Key-tone Traction Company has given notice that it will incorporate with the following, John J. Patterson, William B. Given, J. H. Brown, John D. Skiles, Silas M. Patterson and others.

**PITTSBURG, PA.**—The Denver Consolidated Electric Company secured a verdict for \$26,615 against the Standard Underground Cable Company, in the United States District court. The suit was for rebate for alleged defective cables.

PHILIPSBURG, PA.—The Clearfield Traction Company has received bids for furnishing all material and erecting a boiler house, engine house, car barn and office building.

LOCKHAVEN, PA.—A power house will probably be built in the Nippenose Valley to be operated by water power, for the road that is being projected by Peter Voneida, Nippenose Valley, and others. Subscriptions are being secured.

EAST STROUDSBURG, PA.—The Delaware Valley Electric Railway Company, a 40-mile road from Stroudsburg to Port Jervis, is in the market for eight engines of 200-horse-power each, trucks and sixty cars. Contracts have been let for everything else.

MECHANICSBURG, PA.—The Mechanicsburg & Boiling Springs Electric Railway Company has been incorporated with \$100,000 capital by John B. Skyles, Martinsburg, president; S. Ritter Ickes, Richard B. Zeigler, William K. Meyers, J. E. Knepp, Harrisburg.

NORRISTOWN, PA.—The Norristown & Perkiomen Creek Electric Railway Company has been incorporated with \$150,000 capital by Thomas W. Regan, Paul W. Smith, Harry E. Parsons, James J. Regan and Arthur W. Depue, all of Philadelphia. The road is to be twelve miles long.

KINGSTON, PA.—The Kingston Car Wheel Company has been incorporated with \$20,000 capital to manufacture iron and steel car wheels. The directors are: R. B. Brodhead, S. B. Vaughn, Frederick Corss, E. E. Hoyt, George Shoemaker, George Loveland and Frank C. Sturges.

NORRISTOWN, PA.—The consolidation of the Norristown, Bridgeport & Conshohocken Traction Company, Norristown Passenger Railway Company and Montgomery County Passenger Railway Company, has been effected, and Daniel W. and James B. Shepp are in full possession.

PITTSBURG, PA.—The Baum Street Railway Company, capital \$10,000, and the Highland Park Street Railway Company, capital \$25,000, have been incorporated. Senator William Flinn is president of both companies. The Liberty Traction Company, capital \$70,000, has also been incorporated with John F. Scott president.

READING, PA.—The Reading & Womelsdorf Electric Railway Company, John A. Rigg, president, and M. C. Aulenbach, secretary and treasurer, is about to build a 15-mile road between the two cities. Subscriptions to the \$250,000 capital stock are being received at the office of the Reading Traction Company, which company will operate the line when completed.

PITTSBURG, PA.—It is reported that the Second Avenue Traction Company means the consolidation of the McKeesport & Turtle Creek Street Railway Company, McKeesport & Wilmerding Street Railway Company; McKeesport & Reynoldton Passenger Company; Homestead Street Railway Company and another company which will build through Elizabeth. New York capital is interested, the deal having been made by Brown & Bros., New York. A permit for a \$10,000 power house has been taken out.

### Rhode Island.

PROVIDENCE, R. I.—The Union Railroad Company wants to build a belt line around the city.

### South Dakota.

HOT SPRINGS, S. D.—Charles J. Stackpole, Pittsburg, Pa., has asked for a franchise for the Hot Springs & Wind Cave road, proposing to build 12 miles of electric line. It will be a water power road.

### Tennessee.

CHATTANOOGA, TENN.—The Chattanooga Electric Street Railway Company will extend its line.

NASHVILLE, TENN.—The West Nashville Dummy Railroad Company was sold December 12 at auction.

NASHVILLE, TENN.—The car sheds of the Nashville Street Railway Company and several cars were burned. Loss, \$29,500.

NASHVILLE, TENN.—A receiver is wanted for the McGavock & Mt. Vernon Horse Railroad Company, Nashville & Edgeville Street Railway Company, and Nashville & Edgeville Street Railroad Company, Consolidated.

### Texas.

CORSICANA, TEX.—The Commercial Club will give information relative to an electric railway franchise.

FT. WORTH, TEX.—T. P. Worthington has bought, at receiver's sale, the North Side Street Railway Company, including power house, etc., for \$25,000. It is proposed to spend \$50,000 on improvements.

### Utah.

SALT LAKE CITY, UTAH.—The Salt Lake City Street Railway Company will extend its lines.

### Virginia.

ROANOKE, VA.—The Roanoke Street Railway Company will extend its line.

NORFOLK, VA.—The Norfolk City Railroad Company will extend its line to Portsmouth and Berkley.

RICHMOND, VA.—It is probable that the street car line to Barton Heights will be extended to Ashland by Major Ginter.

### Washington.

PUYALLUP, WASH.—W. N. Coler & Co., trustees, have been given a franchise for an electric line.

FIDALGO CITY, WASH.—The Fidalgo City & Anacortes Railway Company has been sold under foreclosure to the California Safe Deposit & Trust Company. The road was built in boom days, but never operated.

TACOMA, WASH.—The Tacoma Traction Company has been incorporated with \$500,000 capital by Stuart Rice, Charles S. Fogg and George B. Blanchard. The company will build and operate suburban roads in Pierce county.

### West Virginia.

CLARKSBURG, W. VA.—The Clarksburg & Suburban Street Railway Company has been incorporated.

KINGWOOD, W. VA.—Parties are at work raising money for an electric line to Morgantown and to Uniontown, Pa.

### Wisconsin.

OSHKOSH, WIS.—J. K. Tillotson has begun work on the proposed interurban road.

MILWAUKEE, WIS.—City council has passed an ordinance requiring street cars to be heated.

APPLETON, WIS.—The Appleton Edison Electric Company is figuring on building an electric line to Neenah.

ASHLAND, WIS.—The Ashland Lighting & Street Railway Company will extend its lines to the county fair grounds.

WAUKESHA, WIS.—C. E. Loss & Co. have secured the contract for building the Waukesha Beach Electric Railway, six miles.

MILWAUKEE, WIS.—The North Greenfield Division of the Milwaukee & Wauwatosa Motor Railroad will probably be equipped as an electric line next summer and operated by the Milwaukee Street Railway Company.

### A NEW AND HIGHLY IMPORTANT LUBRICANT.

We have been watching with much interest for the past few months the progress in the tests of a new lubricant which, while equally adapted to a large variety of uses, commends itself with special force to street railways. The ingredients and manner of manufacture is a trade secret, although the elements composing the compound have long been known to chemists as the ideal lubricant. The trouble has always been, no one has until now succeeded in commercially combining these elements. This has now been accomplished by the Allerton Lubricant Company, of Chicago, at the head of which is the well-known millionaire, Samuel W. Allerton, and who has facetiously nicknamed one of the many brands of the lubricant "Farmer Allerton's Axle Grease." While it is without doubt the finest grease for all kinds of wagons, one application lasting an entire week on the heaviest kind of work, and this compound has already scored remarkable records on rock breakers, stamp mills, concentrators, and the roughest, heaviest machinery, we are more interested in its application to power house and car service. The nature of this lubricant is such that it cannot waste, but is every bit actually used. On July 6, last, Superintendent Bowen, of the Chicago City Railway, had it applied to the wheels of several electric motor cars running on a very dirty street over an old track and climbing a heavy grade at viaduct. The conditions were admittedly the most severe he could offer on his entire system of 150 miles. Not only have there been no hot boxes, but the one application has lasted until now, making a daily run of 150 miles per car, and to all appearances is as good as the day it was put on.

There has been a very small percentage of waste, and it will eventually have to be renewed, of course, but that date seems a long ways off even now, after steady use for five months. Mr. Bowen states that the journals of these cars have more pressure per square inch of journal than a loaded freight car. On steam roads surprising tests have also been made, using the new lubricant on one side of passenger and freight cars and the grease in use by the railroad company on the other side. While there have been frequent hot-boxes from fast running and heavy loads on one side, there failed to occur a single instance of over heating on "Farmer Allerton's" side.

The compound is of the consistency of a good hard grease, and therefore can be used most economically, as it does not spill or waste.

For a limited time to introduce the compound the Allerton Lubricant Company, whose general offices are in the Old Colony building, Chicago, will send free to any street railway superintendent a sufficient quantity with which to make a complete test. It can be used with equal success on bearings, axles, gas engines, motors, and in fact on anything but members of a city council.

### THE PARAGON INSULATING COMPANY.

The Paragon Insulating Company, Cleveland, O., has made rapid strides for a concern that has been in business but six months. Only the merit of its specialty, combined with the ability of those interested in the management of the business enabled it to attain its position. The object of the company was to supply a first-class insulating paint, which has been placed on the market as the "Acme insulating paint." It has the various qualities of other insulating paints, while the proprietors profess it has the additional quality of being an oil-proof paint, which is a boon to street railway men. The paint is the outcome of a long series of trials and experiments of the Meriam & Morgan Paraffine Company, which has for a quarter of a century been in the petroleum trade and conceived the idea of making an insulator out of petroleum products. The customers of the Paragon Insulating Company are of that class which is not accustomed to use an article in large quantities until it has been proven by many experiments to be all that is claimed.

E. B. Meriam, the general manager, has been with the Meriam & Morgan Paraffine Company for many years. He personally has charge of the manufacture of the insulating paint and of the asphaltuk.

Asphaltuk is a new product that sells principally to wiremen and conduit manufacturers. It is delivered in a solid state, to be melted by the purchaser at the point desired. It is said to be an excellent penetrator and to leave a good black finish.

The officers of the Paragon Insulating Company are: J. B. Meriam, president; E. B. Meriam, treasurer and general manager; F. E. Abbott, secretary; Howard L. Browning, general manager sales department. The offices are at 1025 Society for Savings building.

### SELLS OAK STREET RAILWAY TIES.

W. B. Crane & Co., with a yard and office at Canalport avenue, Johnson and Twenty-second streets, Chicago, have enlarged their facilities for furnishing oak street car ties. Chicago street railroad companies have recently bought 275,000 oak cross-ties from the firm, as follows: West Chicago Street Railroad, 125,000; North Chicago Street Railroad, 100,000; Chicago General Railway Company, 30,000; Calumet Electric Street Railway Company, 20,000. The firm is one of the oldest engaged in the hardwood trade in Chicago, and, in addition to street railway ties, handles all kinds of hardwood lumber. A specialty is made of prompt deliveries of oak ties direct from the firm's own mills.

George Cradock, head of the extensive wire works at Wakefield, Eng., spent several days in Chicago the present month and favored the REVIEW with several calls. Mr. Cradock will reach home about January 1, having made an entire circuit of the globe, and visiting all the larger cities on his route.

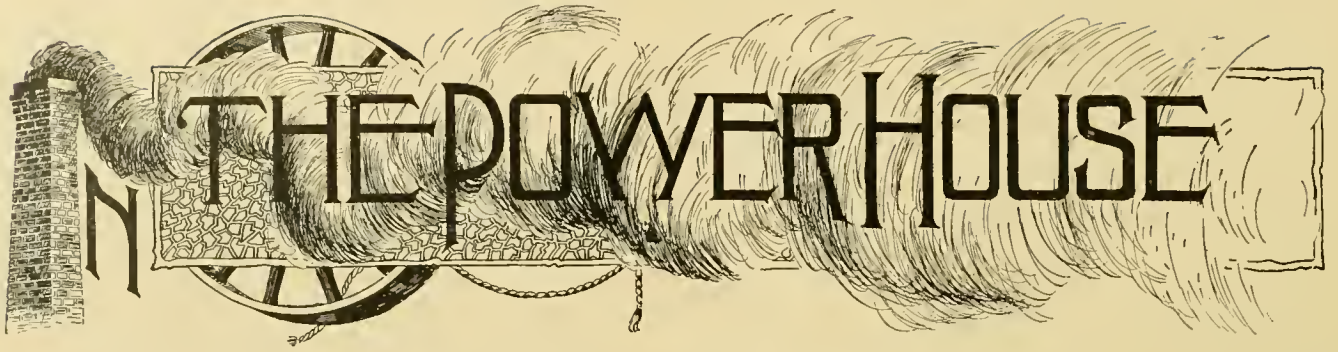

*This department is devoted to the construction and operation of electric railway power houses. Correspondence from practical men is specially invited. Both the users and makers of power house appliances, are expected to give their views and experiences on subjects within the range of the department.*

Always leave plenty of room behind a switchboard. It is a warm place to be in at times. Careless men will occasionally work behind them when they have no business to and again it is necessary to work behind them when the lines are alive, so that there is always a possibility for accident, and the more room allowed the better. If a man gets a shock in a narrow space he is liable to fall across the terminals and some of his tools with him. A case recently came under our notice where a man spent several weeks in a hospital and came out looking as if he had been run through a thrashing machine as a result of working behind a switchboard of a railway station when the lines were alive. He was found lying across the bus bars, a position he would not have been in had there been more room.

\* \* \*

Chief engineers should insist on care on the part of switchboard and generator attendants as to personal safety. It is usually thought that it is an employe's own business if he wants to take risks when he knows the danger he is running. This may be in a sense true but danger to an employe means danger to a station aside from any considerations of humanity. If the chief engineer is known by the employes to decidedly disapprove of any exhibitions of personal reckless it will have a good effect in making his assistants more careful not only of themselves but of the apparatus under their care.

\* \* \*

#### Direct Connected Units.

BY THOMAS ELLIOTT, CHIEF ENGINEER, ATLANTA CONSOLIDATED STREET RAILWAY.

I notice the wail of "One of the Old School" in the last REVIEW, and hasten to help to mitigate some of the misgivings he has about direct connected generators, because if he intends to stay in railway power houses, he will be obliged to operate the machines he now has doubts about. Of course there are direct connected machines running that were never properly designed, just as there

are lots of belted machines that ought to be in the scrap pile. The first direct connected plant that I visited was a revelation (no Indiana frog-pond about it).

The engine was a plain Corliss 32x60, running 95 per minute, and, with the exception of a little humming of the armature, was practically noiseless. The load varied from 1,500 to 2,500 amperes. The engine at that time was pulling about 75 cars and several of them had trailers. A few days after, I visited a belted station of about the same capacity, and the first impression was painful. However, a first impression will depend altogether on what station is visited. In regard to brushes running bad on direct connected generators, this is simply a matter of correct design and management. There are direct connected machines that run noiseless and sparkless and with no more trouble than the best belted machines. "Old School's" statement that belted machine commutators will last at least five years, is only good in some cases because we have had commutators wear out in two years and others that apparently will run ten years. "Old School" again ventilates the old saw about short circuits and shocks on the engine. Where is the direct connected plant that has suffered from this cause? My opinion is that direct coupling is the proper thing for the engine, and already some of the leading engine builders much prefer to build engines for direct connection. He says variations come quick as a flash, and there is nothing to cushion them. Well, what is the need, let them come. The direct connected unit can stand it a great deal better than a long stretch of cow hide which fits the back of an ox better than any thing in an electric plant. Once more, "Old School," there are direct connected machines built with the brush-holders, so that they move with every movement of the shaft. This is to overcome the imaginary trouble that "Old School" has in mind, but with any decent engine it is entirely groundless. Whatever may be the trouble with oil on the smaller sizes, we know nothing about it on the larger sizes. We operated our road for five years with machines belted from a counter-shaft; then we operated it direct-belted, and now the direct connected is carrying the load and the belted machines were consigned to the "Old School," where, between them and the scrap heap, I hope they will stay. The direct connected is better for several reasons. There is not near the liability for a burn out. There is no nuisance of a belt and accompanying noise, and the care and operation is precisely the same as a first



class belted machine. The advent of the direct coupled was the first evidence of good engineering in the generation of electricity. Let the good work continue.

\* \* \*

The Model Plant of the Fairhaven & Westville Railroad, New Haven, Conn.

The Fairhaven & Westville Railroad, of New Haven, Conn., recently started up a power plant that is an excel-



A. U. JAASTAD.

lently modern engineering. The work began early in 1894, when the company secured the services of Sheaff & Jaastad, engineers, of Boston, to supervise the work of construction. These gentlemen were eminently fitted for the task on account of previous experience in the actual construction and operation of power plants, and the station as completed

bears all the marks of good engineering. No small amount of credit is also due to President H. S. Parmelee, who has had personal control of the work.

Work began early last spring and current was furnished from the station early last month. The location of the power-house is on Grand avenue at the Mill River, from which water is taken for condensing. The lot

being made land it was found necessary to drive piles as deep as 40 feet in some places before striking solid bottom. Over 900 spiles were used under the foundations. The spiles were cut off one foot below mean high water and concrete was filled in around them. They were then capped with stone.

The outside dimensions of the power-house are 113 by 82 feet. The inside dimensions of the engine room are 109 by 49 feet. The boiler room is 97 by 28. The offices are 11 by 14. The chimney is 140 feet high, with a 6½-foot core. The building is laid out for a capacity of 2,000 horse-power, 1,000 of which is now installed. The engines are compound condensing corliss, made by the E. P. Allis Company, Milwaukee. The selection of an engine from so far distant a manufacturer is a striking testimonial of the high opinion in which these engines are held by railway managers. The engines have cylinders 16 and 30 inches by 36-inch stroke and run at 90 revolutions a minute. The bases are of the Allis 1890 patent. The condensers are independent, one being provided for each engine. They are known as the Allis fly-wheel vertical jet condensers.

The boiler feed pumps are of the "Knowles" make and are in duplicate. These pumps are so piped that either one can be used for fire purposes. The heaters are of the Goubert make, one being placed in the exhaust



H. S. PARMELEE.

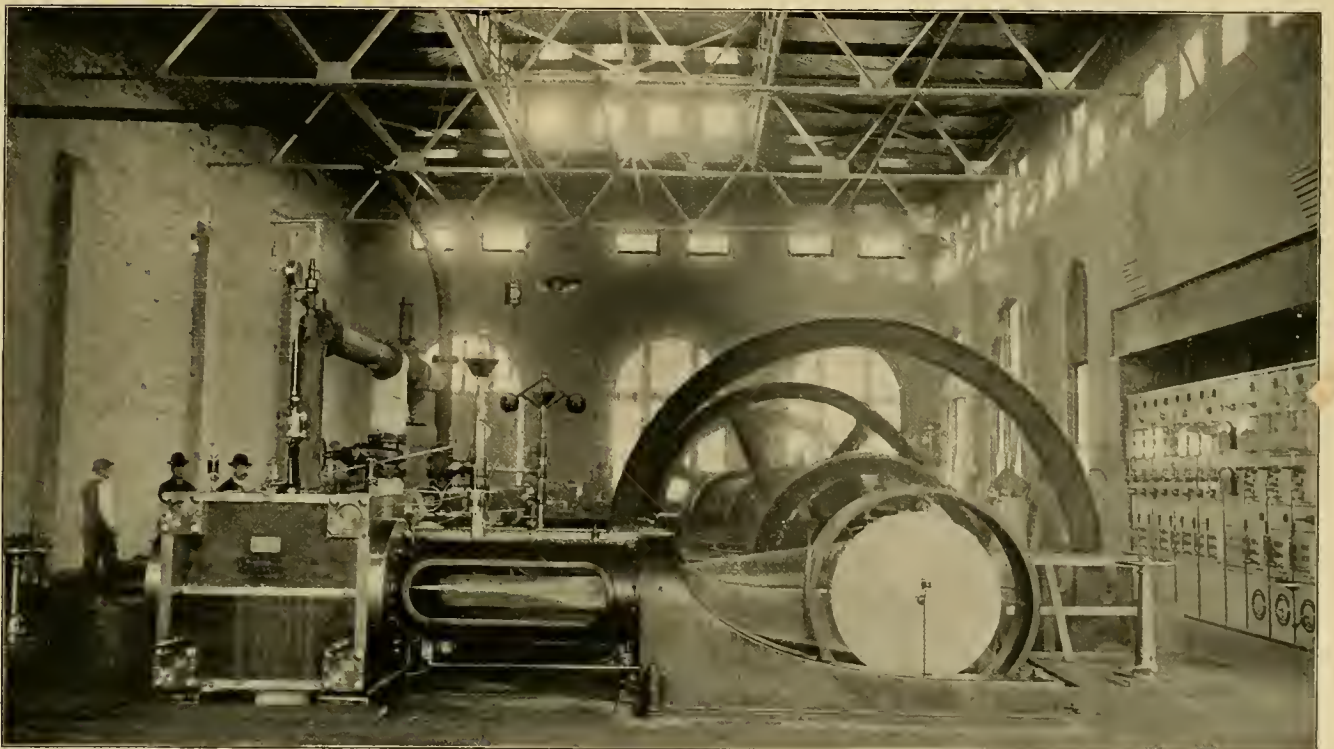

IN THE POWER HOUSE—FAIR HAVEN AND WESTVILLE RAILROAD, NEW HAVEN, CONN

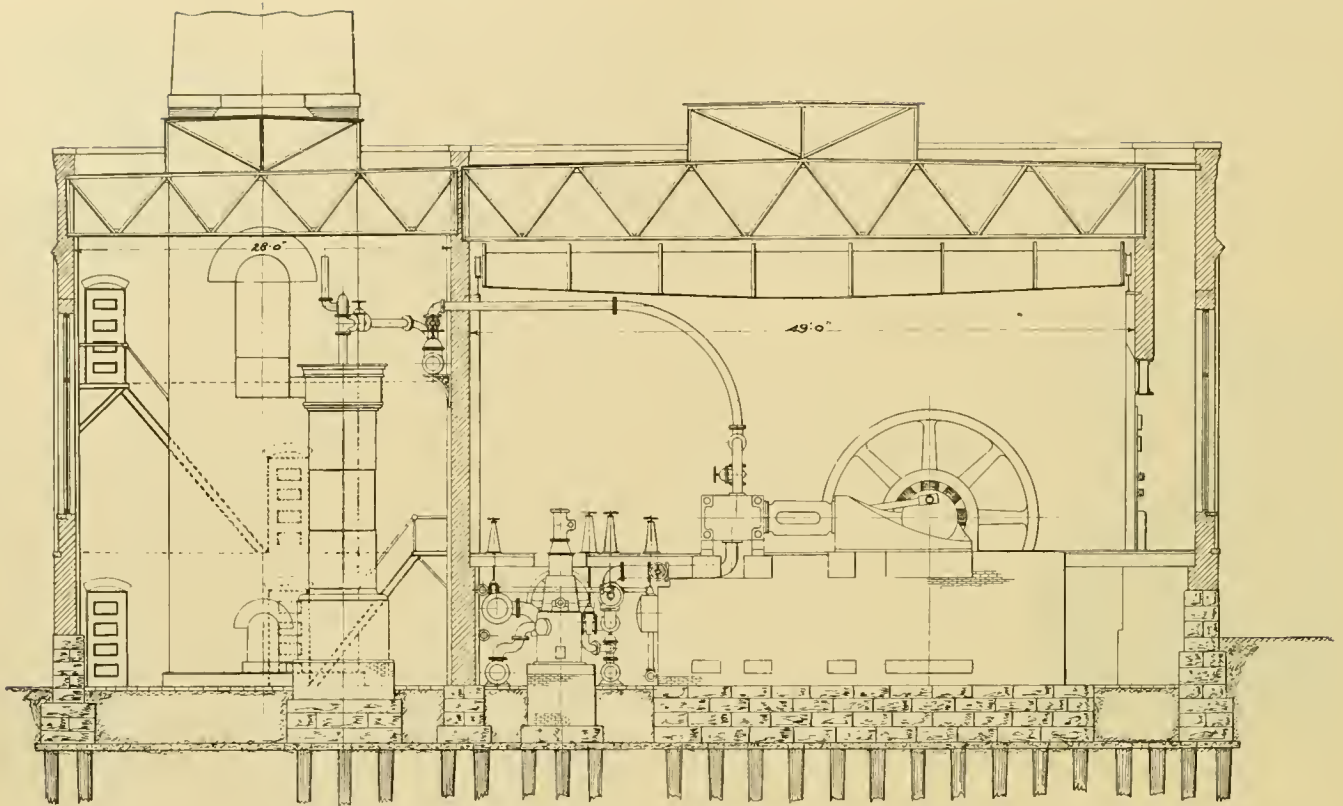

ELEVATION POWER HOUSE—FAIRHAVEN &amp; WESTVILLE RAILROAD—NEW HAVEN, CONN.

pipe, between each engine and its condenser, and an auxiliary heater located in the boiler room into which the exhaust steam from the condensers and pumps is piped.

The arrangement of the heaters is such that water is passed first through the heaters located in the exhausts of the engines, where it is heated to about 120 degrees,

and then through the auxiliary heater in the boiler room where it is heated to about 200 degrees, and from there into the boiler. piping was carefully laid out so as to secure the best possible results, the arrangements of the steam piping being such that should a break down occur in any part of the piping it would be impossible to cripple the plant. Short turns and right angle elbows have been discarded and long bends put in wherever practicable. The engines are provided with a main free exhaust pipe which can be used whenever it is found necessary to run high pressure.

In piping for the feed water for the boilers there were provided three different ways for feeding the boilers, making it almost impossible that any accident should render this important adjunct of the plant inoperative.

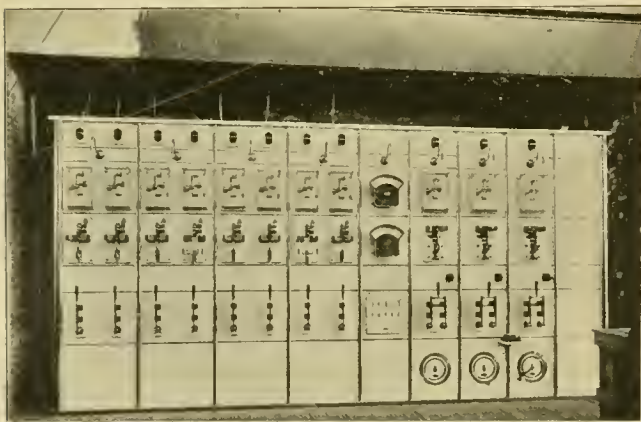

SWITCH BOARD.

and then through the auxiliary heater in the boiler room where it is heated to about 200 degrees, and from there into the boiler.

The boilers are of the "Manning" type and were furnished by the Bigelow Company of New Haven, Conn. The draft is controlled by a "Spencer" regulator attached to the main damper located in the extreme end of the smoke flue before it enters the chimney. The



EXTERIOR OF POWER HOUSE.

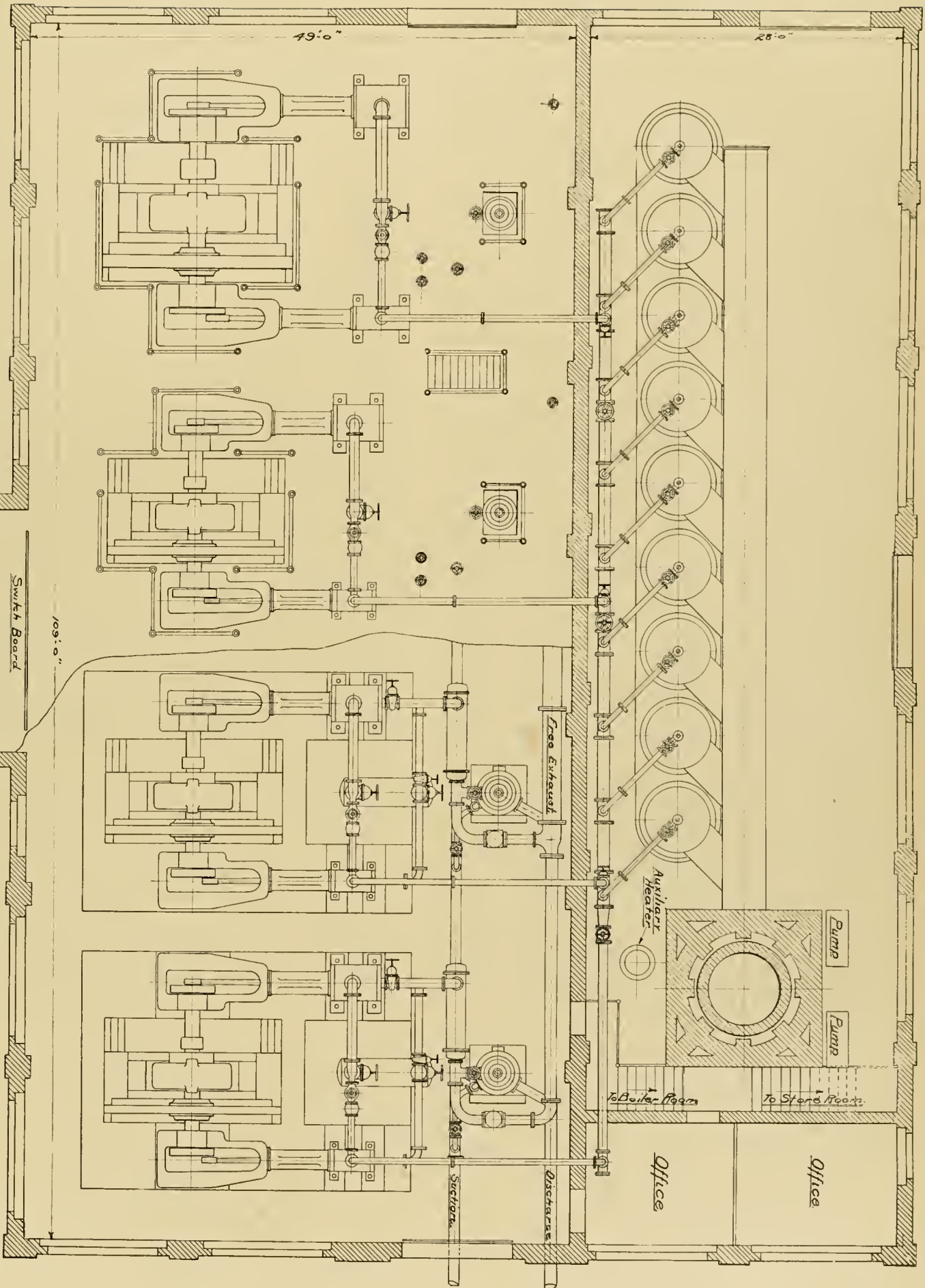

PLAN OF POWER HOUSE—FAIRHAVEN & WESTVILLE RAILROAD, NEW HAVEN, CONN.

The generators are furnished by the Westinghouse company and are direct connected of 300 kilowatt capacity.

The switch board is white marble trimmed with yellow brass and is provided with switches and instruments of the latest improved makes. The board and fixtures were furnished by the Westinghouse company. A feature in the arrangement of the switch board is that it is flush with the wall of the engine room, an off-set having been built onto the building into which the wires are run, from the outside, passing directly down through the flue to the back of the board, thereby concealing the wires, which are so frequently seen in the engine room.

The road is at the present time operating twenty cars, the electrical equipment of which was furnished by the Westinghouse company. More cars will be added as fast as possible until it is fully equipped, when it is expected it will operate about forty cars.

Throughout, the aim of the the constructing engineers has been to design and install in such way as to secure all the advantages of good and economical location and connection, with generous supply of room, steam and power, and yet to do so at a minimum expense consistent with good practice. They have succeeded to a degree highly complimentary to themselves, and satisfactory to the owners of the plant. Our illustrations and plans will give a very intelligent idea of the lay out, and are worthy of careful study.

THE ST. LOUIS ELECTRIC BRAKE.

An electric brake has been in use for five months on a car of the St. Louis & Suburban Railway, engravings of which are shown herewith. It acts simply on the principle of a solenoid, operated by the trolley current,—the

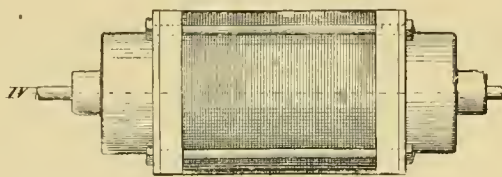

FIG. 1.

solenoid taking the place of the brake cylinder on an air brake. A form of solenoid has been devised which gives a powerful pull, with a small amount of energy and does not tighten the brakes with a jerk. Figure 1 shows the

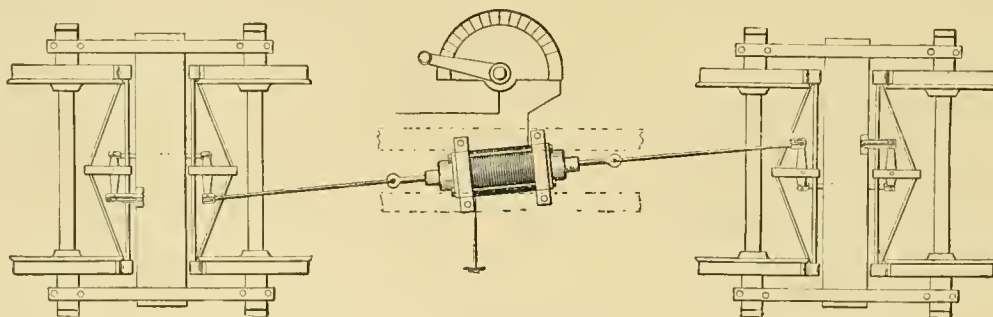

FIG. 4.

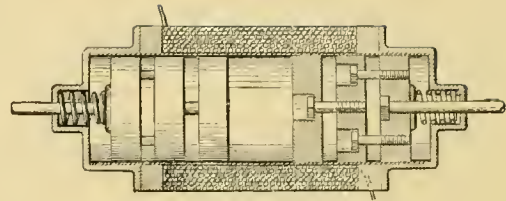

FIG. 2.

exterior of the solenoid, which, for a 16,000-pound double truck car, is 21 inches long, and has cores 5 inches in diameter. The wire coil is 18 inches long, and has ten layers of No. 10 wire. With an outside resistance of proper amount the brake will take 10 amperes and make an emergency stop. Figure 2 is a section through the solenoid as it appears when the brakes are released. Figure 3 is a section through the solenoid with the brakes applied. Figure 4 shows the equipment as applied to a double truck car. The peculiar divided magnet cores are employed to give a powerful application as the brakes become nearly set. This apparatus is being exploited by the St. Louis Electric Brake Company, on the directorate of which will be found J. L. Black, the inventor of the brake; P. M. Kling, vice-president and general manager of the St. Louis Car Company; W. V. Wolcott, president St. Louis Car Coupler Company; Samuel Resh, in charge of air brake repairs on the Missouri Pacific, and others not connected with railway work. Cars are now being equipped for the Union Depot Railway, St. Louis, the Toledo & Miami Valley Railway, of Toledo, O., and the Lancaster, (Pa.), Traction Company. It is certainly a great improvement over hand braking, as far as quickness and ease of application is concerned. The men at the head of this enterprise are good evidence of its integrity and merit, and our readers may expect to hear from the brake in the near future.

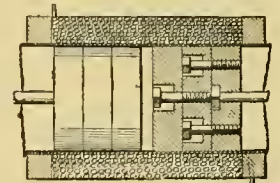

FIG. 3.

The many friends of B. F. Harris, Jr., the enterprising manager of the Urbana & Champaign Electric Railway, will regret to know that he has recently passed through a severe sickness, and has gone to Bermuda to remain until his health is recovered, which time, we hope, is not far distant.

## REVIEW OF THE YEAR WITH OUR ADVERTISERS.

As a Rule, Trade Has Exceeded Expectations.—Customers Increased On An Average of 30 Per Cent.—  
Bright Outlook For 1895.

The supply business for 1894 is practically closed. During the remaining two weeks there will be few large orders, and, aside from small lots of supplies for immediate use, comparatively little purchase of renewals. The manager is now trying to squeeze through December as economically as possible in the effort to help out this year's statement. Then, as usual, he will stock up in January, for there are only twelve hours between this year and next, and he has twelve good months, full of promise in sight, from which to pay; and so we may say the supply business for 1894 is now practically ended. It has been in many respects a curious year. Many who hardly dared to hope to pull through have toiled manfully at the oars and have brought their craft into shelter. Others who, while not fearing the storm, scarcely expected to do more than keep her head to the wind, now are pleased to find a very creditable record in the log book. Some tied up in port and did little more than keep up steam, and in readiness to charter the moment a cargo was offered at paying rates. Only a few, and those were craft where the barnacles of rash expenses or the toredoes of bad credit had weakened the hull, went to pieces in the rough water. The wrecks were surprisingly few, but as a rule went down with all on board, and are hardly worth raising.

The effect of the past twenty months has on the whole been a salutary one. Competition among manufacturers and absolute plunging by promoters had reached a point which not only could not long continue, but was beginning seriously to threaten the welfare of established and legitimate enterprises. When the collapse occurred the bags were punctured and those traveling on wind fell. True, many worthy schemes went down in the deluge, but they are steadily and firmly raising their heads and re-asserting their merits, and are only deferred for a time. When they do regain their feet it will be on a firmer foundation and with less crowding of the road they seek to travel.

It is a matter of congratulation that sellers continue to adhere to strict terms of sale, and that uncurbed credit has for a long time, at least, been turned down. There has been a general decline in prices, it is true, but on many articles the old prices were unreasonable and maintained only through a lack of knowledge on the part of the buyer as to actual cost of production and the small number of competitors. Especially has this been true in the item of railway motors, a much superior article of which can now be purchased at one-third the price the old style motors so readily commanded two years ago. Indeed, in this line competition has been so active that large orders have been accepted at prices it is difficult to believe can yield any margin of profit. This is, in one sense, of advantage to the buyer. At the same time no business can afford to sell at cost nor

should buyers expect it. Generators have also suffered in price, but not quite as severely.

Cars are also subject to exceedingly close figures, and with the large number of bidders and the restricted demands of the year have made the year an anxious one for those with large plants engaged in this work. The small orders have commanded fair prices, but the large ones which have constituted the bulk of the business have been placed on a basis of profit never before offered the buyer.

Rails have been in better demand than was anticipated and at lower prices than ever.

The small supplies, overhead materials and car accessories have, as a rule, fared very well. On the whole, there has been both more of new construction, renewals and betterments than was anticipated.

Now, what of the outlook. From a careful study of the field as a whole, we are satisfied the opening year will be a good one for street railways and those supplying them. Confidence has been restored; investment has evinced a disposition to venture from its hiding, and while still timid and cautious, is steadily gaining ground and more inclined to favorably consider propositions, which, for a time, could not even secure a hearing. The return to active investment will be slow and by easy stages, but each encourages another, and with an abundance of really very meritorious and deserving opportunities there need be no fear but that such will soon find takers. With the cost of construction both in labor and materials, and the cost of equipment lower than ever before, the present is really a most opportune one for capital. There are several thousand miles of city and interurban lines, which would to-day pay from the start, that have been held in abeyance or have come to maturity during the period of depression; that are now fully ripe for development. Managers, also, have now demonstrated ability to forecast construction and operating expenses and earnings with such a degree of certainty that the ordinary investor feels he knows what he is assuming in entering the field. All this, with the surprising ability of roads to adapt themselves to straightened circumstances, to an extent heretofore believed impossible, combine to create a healthful condition which is full of promise.

Each new enterprise will make possible another, and by the middle of '95, unless some great and unpredictable disaster, no more liable now than any other time occurs, the demand for materials will be so active that prices will have a strong upward tendency. Contracts placed the first quarter will almost certainly be taken at a much lower figure than can be obtained thereafter.

Industries are gradually regaining activity, which means immediate relief to street railway earnings, which in turn means ability to pay additional interest on new capital. Hence we anticipate a good, strong, steady

business in the street railway field for 1895. With the exception of new devices and small supplies, the field is not at present particularly inviting for the large investment of money in new plants for the manufacture of street railway supplies. Present plants, as a rule, have facilities sufficient to take care of business in sight for some time to come.

The Paige Iron Works, Chicago, has built the special work for the Metropolitan Elevated Railway Company, Chicago. The outlook for next season is "good."

The Partridge Carbon Company, Sandusky, O., has had a satisfactory year, increasing its customers twenty per cent. The company has placed on the market self-lubricating brushes. The outlook is "good."

The Storm Manufacturing Company, Newark, N. J., has had a satisfactory year, with an increase of 400 per cent in customers for its sleet-cutting trolley wheels, which have been described in the REVIEW. The outlook is "good."

The Johnson Company, Johnstown, Pa., says its business last year was very large, although prices were correspondingly low. "The outlook next year is decidedly bright, and we have no doubt we will, as usual, have all we can do."

The Weston Electrical Instrument Company, Newark, N. J., has had an increase of 50 per cent in customers. The capacity of the plant has been doubled and the round pattern railway instruments put on the market. The outlook is "good."

The Mica Insulating Equipment Company, New York, and Eugene Munsell & Co., have had a very good year, increasing their customers one-third. New mica insulations were placed on the market, and a good foreign business was received. The outlook is "good."

The C. D. Morse Car Manufacturing Company, Millbury, Mass., has added to its customers a small per cent. No new devices, except for use in the works, were brought out during the year. The company believes it is "too early to estimate for 1895."

The Farist Steel Company, Bridgeport, Conn., has doubled its business in street car springs. An addition has been built to the rolling mill. The outlook for 1895 is a "fair business in this line, and should general business improve as we hope, very good."

The Fuel Economizer Company, Matteawan, N. Y., has seen fulfilled its expectations, with reference to trade. The foundry has been enlarged. The company has perfected new beveled edge, triple scrapers for the tubes, and an internal lid for top headers, to do away with bolts altogether for high pressures. The outlook for 1895 is "good."

The Watertown Steam Engine Company, Watertown, N. Y., has done fairly well during the year, and has increased its foreign business, making shipments to India and Africa. The full force has been worked full time all the year and night and day part of the time.

Shiffler Bridge Company, Pittsburg, has found business fully equal to expectations, with an increase in new customers of nearly 20 per cent. The company is now preparing plans for a large machine and blacksmith shop, to be erected at once. "The outlook is encouraging."

The Philadelphia Electrical Equipment Company, Philadelphia, is new in the business. It is equipping the League Island Navy Yard, as sub-contractor, with a sixty-day limit. Prospects for next season are "the best possible, there will be many interurban roads built, and the prospects are very bright."

The Shultz Belting Company, St. Louis, finds that the year's business has been beyond its expectations, and there has been an increase of 10 per cent in customers. A new hydraulic press has been added to its equipment. The well-known trade mark of the company, consisting of two worlds connected with a belt, is to be seen on many roads.

The Fitzgerald-Van Dorn Company, Lincoln, Neb., has increased its customers 40 per cent. An automatic draw bar, for elevated railroads, was put on the market, and the company has equipped the Metropolitan Elevated Railroad, Chicago, with the device. The company is also building special automatic draw bars for cable roads. The outlook is "very bright."

The Paragon Insulating Company, Cleveland, O., has only been in business six months, but the volume of trade has met all expectations. Howard L. Browning, formerly with the Edison Company, New York, has been made general sales agent. The company has bought out the Paragon insulating paint and "asphaltuk." The outlook for next year "is better than ever before."

The Hubley Manufacturing Company, Lancaster, Pa., has had more business than it expected. The new plant of the company is said by the officers to be the most complete and best appointed plant in the state. Many new devices have been put upon the market. One of the contracts was for the equipment complete of forty-three miles of electric road. The outlook for next season is "good."

The Ashley Engineering Company, New York, has received 20 per cent more customers. A new straight-way valve, a new check valve, and a new radiator valve, have been brought out. The check valve is meeting with favor, as it is complete in three pieces, and works in either a vertical or horizontal pipe, has no springs or pivots, and is first-class in workmanship, and low in price. The outlook is "very good."

The St. Louis Register Company, St. Louis, has increased its business way beyond expectations. Over 40 per cent has been added to its list of customers. Some expensive additions have been made to the plant, increasing its facilities for turning out the "old reliable security" in large quantities on short notice. "We believe 1895 will be the banner year for street railway supplies, especially for security registers."

The Lewis & Fowler Manufacturing Company, Brooklyn, N. Y., reports business equal to its expectations. President H. H. Dollard resigned and Charles C. Van Anglen was elected president pro tem. The other officers are: D. F. Lewis, treasurer; George W. Myers, secretary, and C. G. Dobbs, manager. The Acme car jacks were put on the market and improvements made in electric snow sweepers. The outlook is "very good."

The California Wire Works, San Francisco, Cal., had a business as good as was expected. The increase in customers was 10 per cent. No new devices were brought out. A number of cables were shipped to street railways of St. Louis and Pittsburg. The company also completed the Mt. Lowe Incline, Pasadena, Cal. A large business was done in Oregon, California, Washington and Mexico with the Hallidies ropeways. The outlook is "improving."

Warren, Webster & Co., Camden, N. J., have largely increased their customers. An addition was built to the boiler shop for making wrought iron heaters. Three new patents have been secured. The Canadian business is increasing. New machinery has been put in. One 2,500 horse-power Webster heater and purifier and the Williams system of steam heating, were sold to the Westinghouse Electric and Manufacturing Company, Brinton, Pa. The outlook is "very fair."

The American Car Company, St., Louis, has had a satisfactory business, with an increase of fifty per cent in customers. A \$20,000 addition to the plant has been built and a new single and double truck put on the market. The company equipped 100 cars of one of the St. Louis roads with double trucks and sold 100 open and 200 closed cars to the Electric Traction Company, Philadelphia. The outlook for next year is "fair."

The Griffin Car Wheel Company, Chicago, obtained 20 per cent more customers. The office building at the works was enlarged, new loading platforms were added, a new building for storehouse, and a grinding mill were built, and a new cupola and sundry machines added. Many new devices for use at the works were created, but none were put on the market. Twenty carloads of car wheels were shipped across the Atlantic, which was entirely new business. "No great improvement is looked for over this year."

E. Saxton, Washington, D. C., writes: "Business has been very good. Have been busy on electric lines

in and around Baltimore and on cable construction in Washington, D. C. I am well prepared and equipped for the construction of city and suburban trolley lines, underground electric and cable railways. The cost of construction of both cable and electric railways having been amazingly reduced in the last year or two, I am not without hope that 1895 will see a very large investment in such enterprises."

The Central Electric Heating Company, New York, N. Y., has increased its line of customers 300 per cent. Although the size of the factory has not been changed, the company employs three times as many men as last season. A new style of car heater has been placed on the market. Besides equipping many small roads with American electric heaters, the company has closed a contract for all the cars of the Metropolitan Electric Railroad Company, Chicago. The prospects for next season in this line "are very flattering."

Michigan Electric Company, Detroit, Mich., has no complaint in regard to the business of the year. It has been found necessary to double the store capacity in order to keep up with the demand: The new devices put on the market during the year are the "Michigan overhead material and railway specialties" and lights for electric cars. "We believe the result of the recent election has done much to restore general confidence throughout the country, and we look forward to a very satisfactory year's business in 1895."

The Eureka Tempered Copper Company, North East, Pa., reports through John C. Dolph, general eastern agent, New York, a satisfactory year, which has resulted in the addition to the eastern department of all the New England and a number of coast states, including Delaware, Maryland, Virginia and the District of Columbia. The principal work of the company is in connection with castings for dynamo and motor commutators. Many roads are making it a point to specify Eureka tempered copper when they have commutators to refill.

The Composite Brake Shoe Company, Boston, had more business this year than it expected at the beginning. The customers have been doubled during the year, and old customers have increased their orders. The Cincinnati Street Railway Company has bought 4,100 shoes since May. The company changed its name from Safety Brake Shoe Company to Composite Brake Shoe Company. Additional foundries were built for manufacturing at Philadelphia, Pittsburg and San Francisco. The company, speaking only for itself "considers the outlook very promising."

"Gates, of Chicago." Such is the trade mark of J. Holt Gates, Chicago. "Since passing of tariff bill," he says, "have sold more than factory can deliver, and customers have more than doubled. Have added General western agency of Elwell, Parker Electric Company,

Cleveland, O." The new departures during the year have been the electrical equipment of elevated roads, and direct connected alternating dynamos. One of the good orders, was the equipment of the Elkhart & Goshen Railroad with the Card railway motors and Mather generators. "Judging by amount of inquiries, business next year will be very good."

The Graham Equipment Company, Boston, has had a business that exceeded its most sanguine expectations, increasing its customers ten to one. A new plant was established in Providence with facilities for turning out twenty-five trucks a day. Graham's all-steel push plow, that requires neither extra crew nor motors, and is said to be light and effective and always ready for service, has been introduced. An inquiry for trucks was received from New Zealand. A fire at the Laconia car works in July destroyed the company's patterns, causing a loss of \$50,000 in cancels and inability to deliver goods. On July 26 a truck was on car ready for shipment at 4:30 p. m., the order having been received at 2 p. m. "A conservative business will be done and the payments will be invariably good. We do not expect to build more than 1,000 trucks."

The Ohio Brass Company, Mansfield, O., has had a satisfactory year, October bringing the largest trade, which is remarkable, as it is in the off season. At the beginning of the year only one or two Ohio roads were on the books of the company, but now the list includes nearly every road in the country. Considerable new special machinery has been added to the plant, and the employes increased in foundry and machine shop. The type K trolley insulators, Spillman trolley ear, Jewell trolley sling, reversible and adjustable track brush holder, and many other new devices have been put on the market. The company will equip 75 to 100 miles of the Indiana Electric Railway Company, if the latter's plans are carried out; deliveries have been made on this order. "We believe the coming year will be far better for every one interested in the street railway business than the past year has been. As manufacturers, we look forward to a business which will be several times larger than our business of last year, and, on the whole, we are inclined to take a very hopeful view of the outlook."

C. C. Caldwell, Shelbyville, Ind., will deliver his lecture on a collection of electrical, marine and railroad views, at the Lexington, Ky., Exposition, on two occasions, between Christmas and New Year's Day. In connection with an exhibit of his photographs, he showed in his exhibit space, many special instruments and small electrical machinery. Mr. Caldwell has had a successful season with his lecture, which has interested a great many people.

J. S. Hill, well known as the efficient superintendent of the La Fayette, Ind., Street Railway, and whose work has several times been mentioned in these columns, has resigned, and is now open to an engagement,

## COCHRANE'S RELIABLE ELECTRIC HEATER.

Within the month the Philadelphia Traction Company, has ordered through Charles Mayer, 400 of the Cochrane reliable electric heaters, manufactured by the Reliable Manufacturing Company, 53 State street, Boston, Mass., with a factory at Everett. The manufacturers experimented and investigated many styles of heaters before adopting this one, which they say has raised the temperature of a car to 55 degrees, when the external temperature was 17 degrees, using only four amperes of current, with the voltage 500. The Philadelphia Traction Company adopted the heater after thorough tests in its shops and in service on its cars.

The illustrations show the heaters in place, and a view showing construction. The heaters can be connected in series, in multiple, or multiple series. The heater consists of a metal tube (A) about three feet, six inches long and two inches in diameter, closed at both ends with a cap of

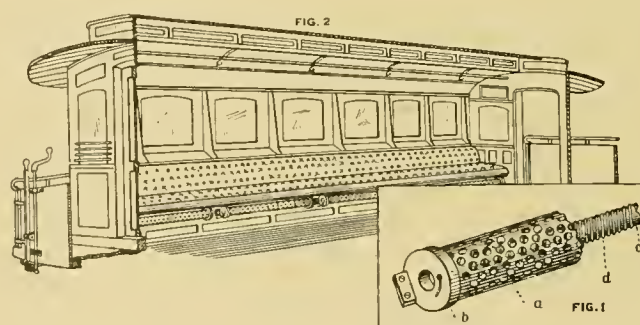

RELIABLE ELECTRIC HEATER.

hard rubber (B). Its sides are perforated. Within is another tube of metal (C) about an inch in diameter, open at both ends. The inner tube has a coating of asbestos around which is wound a spiral of wire (D), which, owing to the resistance which it affords to the passage of the electric current, becomes hot, when traversed by the current. One end of the coil is connected with the trolley, and the other with the ground. Air passing through the inner tube will be heated by contact with the hot wire, and by means of the perforations in the sides of the outer tube a constant circulation of air will be maintained between the tubes, which, being heated by the hot wire, a large volume of warm air will be diffused through the car, while the constant supply of cold air will prevent the wire from becoming excessively hot. It has been found in practice that the tube never becomes so hot but it is possible to bear the hand upon it. A series of tubes is secured end to end, on the rising board of the seat, as shown in Fig. 2, and are entirely out of the way. It is unnecessary to cut or disfigure the car to place them in position.

Frank X. Cicott, manager of the railway department of the Pettingell Andrews Company, sailed on the Lucania, Dec. 1st, for Europe, in connection with the firm's girder rail business with Dick, Kerr & Co., London.



PICTORIAL EVENTS OF A MONTH.

Cleveland is joyous, because there is a strong likelihood that she will secure a trolley mail service. The postmaster wants it, the people demand it, and the post office officials at Washington have given their consent. The only thing to be done is to get it, so the Clevelandites are blowing their horn in expectation of the happy event.

The gruesome looking picture at the top of the center of the page, is in reality not so mournful as it looks. While horse cars are no more in Buffalo, New Hartford, Conn., and several other cities, the municipalities are not dead. They have simply outgrown their garments and cast them off, having clothed themselves in new electric lines. These are signs of life, not of death, for it is the result of progress.

Two bicycle riders in Newport, Ont., were struck by an electric car as they were trying to cross a street. The fender caught them, saving them from injury. The wheels were not so fortunate.

This policeman is not so big as he looks, for he is suffering deep affliction, and is mourning because he has to pay street car fare or walk. He can no longer travel his beat by riding on the cars. New York has voted a constitutional amendment which provides a penalty for any public official who uses a free pass, and a like penalty for the company that issues it. Lawyers have agreed that under the law, policemen and firemen will, after January 1, lose their perquisite of free car rides.

The Consolidated Traction Company, Jersey City, N. J., met with an obstruction, when it tried to set poles in La Fayette. A lady property owner objected to one



One of the cars on a Pittsburg suburban line jumped through an iron fence, and landed on the roof a house about forty feet below. The conductor jumped, but the motorman stuck to his post until the car began to drop, when he was thrown off, being injured internally. Two passengers were thrown against the front door, and when the car struck, bounded to to the rear door, but were uninjured. A small girl, with her baby sister, was passing when the car crossed the sidewalk. The smaller child was caught by the fender, as if she was a tennis ball, and landed on the ground, ninety feet below the point from which she started. A passer by, who saw her falling, was surprised to hear her say, "Mister, please pick me up?" Her injuries were not serious. The track was covered with yellow clay, made slippery by rain. The car began to get away and reverse current was used, but without effect. When the car struck a short curve, it did not take it, but kept on its course.

being placed in front of her premises. The foreman told her he had orders and the right to put a pole up there. As he seemed determined to obey his orders, she jumped in the hole and defied the men to proceed. From 9 until 3 o'clock she "stood her ground," when she was relieved by a watchman.

The Philadelphia Traction Company has received a grant of franchises over 91 miles of streets from the city. This makes quite a bagfull, and will serve to keep out competitors.

San Francisco, like Pittsburg, had a runaway car down a grade. The car only ran through a telegraph pole. There were eight passengers who kept their seats, escaping without injury. The brake beam broke, as the car started, so it was impossible to control the car.

M. F. HEISKELL has been appointed general manager of the Wilmington (N. C.) Street Railway Company.



The Sweet Electric & Manufacturing Company, Grand Rapids, Mich., has increased its facilities for manufacturing, and is able to keep pace with its increasing business.

THE electrical repair work of the League Island Navy Yard, at Philadelphia, has been awarded the Philadelphia Electrical Equipment Company, of which C. P. Young is general manager.

The Falk Manufacturing Company is having good success with the introduction of its trolley wheel, as the wheel makes friends wherever tried. Some of them have made 12,000 miles without any repairs.

Charles A. Schieren & Co., New York, have sold to the Jacksonville Street Railway Company, Jacksonville, Florida, 104 feet of 30-inch, double leather belt, 104 feet 24-inch, 65 feet of 15-inch, and 79 feet of 15-inch belt.

J. M. Denniston, the well-known street railway man, has accepted the agency of the St. Louis Car Company. His office is 1064 Monadnock Building, Chicago. Mr. Denniston is very popular and has a great many friends in the street railway field.

The Alton Electric Street Railway Company, Alton, Ill., has ordered two 150-horse-power Buckeye engines and three 150-horse-power Wangler boilers. The company now has four 150-horse-power Buckeye engines and six 150-horse-power boilers.

The American Electrical Works, Providence, R. I., through its western agent, Francis E. Donohoe, has sold 900,000 pounds of copper feeder wire to C. T. Yerkes, for the North and West Chicago Street Railroad Companies. The contract amounts to \$118,000.

The Wenstrom Electric Works, Calverton, Md., will be devoted almost exclusively to street car equipment, all the lighter work being transferred to Ft. Wayne, Ind. R. T. McDonald, who controls the Wenstrom Company, has recently acquired the Ft. Wayne Company.

The Fitzgerald-Van Dorn Company, Lincoln, Neb., has just finished equipping 100 coaches and fifty-five motors for the Metropolitan Elevated Railroad Company with the Van Dorn automatic draw bar. The company is having many inquiries from cable and elevated roads.

B. M. Barr, of the Walker Manufacturing Company, Cleveland, has returned from a three weeks' trip in the south with orders for a large number of street railway

motors. He closed contracts for several car equipments with the Akron Street Railway Company before he went away.

The Link Belt Machinery Company, Chicago, has sold its standard water tube safety boilers to the Carnegie Library, Braddock, Pa., 50-horse-power; Morgan building, Buffalo, N. Y., 375-horse-power; North Chicago Street Railroad Company, Chicago, 3,000-horse-power.

Daniel Higgins, 1719 West Lombard street, Baltimore, Md., has been awarded the contract for supplying his new style number badge to the conductors of the Baltimore City Passenger Railway Company. A new system of operating the cable and electric lines made a change in the style of badges necessary.

The Storm Manufacturing Company, Newark, N. J., has sent to its friends a paper weight, which is a miniature of its "H. & C." patent ice and sleet cutting trolley wheel. J. H. Graham & Co., New York, sales agents, report many orders, and that every road that has tried them is enthusiastic in their praise.

The Taylor Electric Truck Company, Troy, N. Y., is building several sets of trucks for use under long cars, to run from thirty to forty miles an hour. The company reports that the construction of the Empire State radial truck is liked by practical street railway men, wherever they have had an opportunity to investigate it.

THE Cradock cables have again made a wonderful record, this time on the London (England) Tramway Company's line. A 30,000-foot rope of 1½ inch diameter went into service July 8, 1893, and was still running on October 25, 1894, and far from worn out. It had on this latter date run 67 consecutive weeks, making 67,369 cable miles, or 1,809,000 train miles.

A. O. Schoonmaker, 150 William street, New York, makes a specialty of India mica for street railways, which he is prepared to furnish in any shape. For the accommodation of his western customers, Mr. Schoonmaker has placed stocks with his western agents, H. H. Williamson, 53 Public Square, Cleveland, and Reger & Atwater, 214 Pine street, San Francisco.

The following extract, shown us from a letter recently received by the Brownell Car Company, St. Louis, though short, tells a long story. It is in regard to Accelerator cars, and says:

"THE figure you name us is \$200 higher than any of our other quotations; but we give you the order, trusting you will give us our money's worth and a first-class car in every respect."

The Wheeler Rail Joint Company, New York, New York, has secured two large orders for its rail joints. The Chicago City Railway Company is one of the pur-

chasers, and the West End Street Railway Company, Boston, was the other. The mere fact of two such important street railway companies having become interested enough to buy, is sufficient recommendation of the utility of the Wheeler joint.

W. E. Sharp, agent for the Atlas Engine Company, Indianapolis, has sold two 12-inch by 15-inch tandem cycloidal heavy-duty engines, to be installed in direct connection with three Westinghouse 90-kilowatt machines in the New England Block, Cleveland, a fifteen-story building. The Westinghouse Company will also supply a marble switch-board 7 feet by 16 feet. The engine is the only four-valve tandem compound in the vicinity of Cleveland.

The Consolidated Car-Heating Company, Albany, N. Y., has received an order from the People's Traction Company of Philadelphia for the equipment of 300 cars with its system of electric heating. This is the largest order ever given for electric heaters. Other large orders recently received by the Consolidated Company are: 149 car equipments for the West End Railway, Boston; 187 for the Union Railroad, Providence; 60 for the Nassau road, Brooklyn, and many other smaller orders, aggregating in all about 500 car equipments. The heater is now in use in 100 cities and towns of the United States and Canada and on over 1,300 cars.

Edward F. Austin is in charge of the Pittsburg office of the Phoenix Iron Works Company, Meadville, Pa., manufacturers of the Dick & Church engines, boilers, feed water heaters, etc. He has sold a 15x18 engine to Jones & Laughlin, three 100-horse-power boilers for the Schenley Park Casino. The boilers are particularly designed for safety, and of special make all through. Mr. Austin reports several smaller orders, and looks forward to increased trade in the engine and boiler line. Mr. Austin was formerly sales agent for the Altoona Manufacturing Company, in the Pittsburg district, and was very successful in selling that company's engines.

The J. H. McEwen Manufacturing Company, Ridgeway, Pa., has sold two 150-horse-power simple engines, direct connected to General Electric generators, to the Continental Hotel, Philadelphia; one 300-horse-power simple engine, direct connected to Walker Manufacturing Company generator, to the Akron Street Railway Company, Akron, O.; two 60-horse-power tandem compounds, direct connected to C. & C. generators, to the Dundee Rapid Transit Company, Elgin, Ill.; one 280-horse-power tandem compound and one 250-horse-power simple, to the Scranton Electric Construction Company, Scranton, Pa. In addition are sales of thirteen engines, simple and compound, aggregating 2,125 horse-power.

Charles J. Mayer, Philadelphia, has secured a contract for equipping the cars of the Philadelphia Traction Company, with electric heaters. It will not surprise his many

friends, if Mr. Mayer succeeds in placing his heaters in the cars of all the Philadelphia street railway companies. The heater is known as the Cochrane Electric Heater, No. 2, manufactured by the Reliable Manufacturing Company, Boston. The radiating surface consists of two cylinders, one above the other, and, it is stated, requires no more than six amperes of a 500-volt current to heat the car to a temperature of 30 degrees above that outside. Experimental heaters were placed in cars Nos. 1081 and 1082, which were so greatly appreciated by the patrons of the company, that they took pains to remember the numbers of the electrically heated cars, and wait for them.

J. Holt Gates is installing six Card motor equipments and Mather generators, for the Elkhart & Goshen Railroad. He is also installing for the Bloomington (Ill.) City Railway Company a 100-kilowatt Mather railway generator and two Card motors, and in Fremont, Ohio, two Card motors. The Card Electric Company's factory is now entirely completed, and in active operation. Its series-parallel controllers, with quick break switches, are a new departure in car controllers. It seems strange that other electric companies have not used a similar device before. Mr. Gates reports the sale of thirty-six motors and generators in the month of October. The Elwell-Parker Electric Company, of which he is the western representative, makes a specialty of direct connected alternators, as well as the heaviest class of railway generators. Mr. Gates has five salesmen on the road, as well as an engineering corps.

The Ohio Brass Company, Mansfield, O., reports a large number of initial orders for the reversible and adjustable track brush holders and steel-wire track brooms, which have been followed in almost every case by larger ones. In many instances the entire equipment of motor cars has been provided with these devices. Among the larger roads using them are: The Syracuse Street Railway, Syracuse, N. Y.; the Middletown-Goshen Traction Company, Middletown, N. Y.; the Cumberland Electric Railway, Cumberland, Md.; the Burlington Electric Railway, Burlington, Iowa; the Steinway Railway Company, Long Island City, N. Y.; the Central Electric Railway, Peoria, Ill. "The ease with which these holders can be manipulated," writes the company, "and the saving in consequence in the wear on the track brooms, is a strong recommendation in their favor. Every operator of a street railway company which requires a device of this sort should investigate these before placing his order."

Thomas V. Perkins, vice-president of the Mather Electric Company, Manchester, Conn., deserves much credit for the manner in which he has brought his company among the leaders in the manufacturing line. So many contracts have been placed of late, that the plant is compelled to run day and night to fill orders. Among the contracts are 100-kilowatt new type multipolar generator, two 25, one 20 and one 10-horse-power Manchester

motors, Overman Wheel Company, Chicopee Falls, Mass.; a 60-kilowatt generator, Connecticut River Paper Company, Holyoke, Mass.; one 80-kilowatt new type multipolar generator, Pierpont Manufacturing Company, New Bedford, Conn. (third order); 350 light dynamo, receivers Union Pacific Railroad, Pocatello, Id.; 350 light dynamo, Hub Gore Makers, Brockton, Mass.; 100-kilowatt railway generator, Ithaca Street Railway Company, Ithaca, N. Y.; 15-kilowatt direct connected dynamo, with Ideal engine, Wayne hotel, Detroit; 350 light dynamo (ring type), Meriden Britannia Company, Meriden, Conn.; 350 light dynamo, Berlin Iron Bridge Company, East Berlin, Conn.; 150 light dynamo, Curtis & Howard, Minneapolis, Minn.; 250 light dynamo, C. Dorflinger, White Mills, Pa.; 150 light dynamo, H. B. Coho & Co., New York; three 100 G. K. generators, Congressional Library, Washington. D. C.

### EUREKA SAND BOX.

The sand box shown in the accompanying engraving is being offered to the trade by the Eureka Sand Box Company, of Lebanon, Pa. It was designed by practical street railway men. The action is explained by the engraving. The disc disturbs and pulverizes the sand and the spiral delivers it to the discharge chute. It is operated by

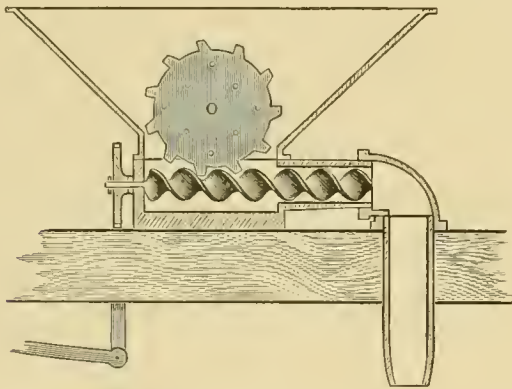

EUREKA SAND BOX.

handle or foot lever. The roads using it are the People's Passenger Railway of Philadelphia, The Schuylkill Electric Railway of Pottsville, Pa., and the Schuylkill Traction Company of Girardville, Pa. The policy of

the manufacturers is to condemn no other box, but to prove worth by practical demonstration. The members of the company are S. P. Light, vice-president of the Lebanon & Annville Electric Railway; Thomas Williams, C. J. Barr, C. B. Andrews, and J. K. Raudenbush. The box seems to be doing good work with both sand and salt.

### NEW PUBLICATIONS.

THE Partridge Carbon Company, of Sandusky, O., is distributing a handy price list of its well known self-lubricating dynamo and motor brushes.

THE Lunkenheimer Company of Cincinnati has issued its 1895 catalog of valves, lubricators and steam engine specialties. Its 107 pages are profusely illustrated with excellent engravings.

C. W. HUNT & Co., have sent us a pamphlet which cannot fail to be of interest to all large power plant owners and builders. It is on the subject of coal handling machinery which has been adopted by several large electric power stations with a great saving in labor. The Brooklyn Heights Railroad is among important users.

THE Barney & Smith Car Company, of Dayton, O., has issued a catalog giving a score of views of exteriors and interiors of street cars actually built by the company, besides a few sketches of trucks, gates, seats and steps. Some of the cars shown have been adopted as standard by different street railways. Although well printed on good paper the engravings can scarcely do justice to the fine workmanship of the cars turned out.

## WARDWELL BROTHERS, Electric · Railway · Builders,

NEW HAVEN, CONN.

BOX 868.

Will make proposals for the Construction of all Classes  
of Street Railway Tracks, Power Houses, Etc.



## ACME Insulating Paint

GLOSSY BLACK FINISH,  
Good Body, Dries at Once,  
Adhesive, Flexible.

Acid and Oil Proof,  
Water and Weather Proof.

The Paragon Insulating Co.

1026 SOCIETY FOR SAVINGS BLDG.,

CLEVELAND, O.

## C. E. LOSS & CO.,

## General Railway Contractors.

Estimates made on all classes of Engineering Work.

621 Pullman Bldg.

CHICAGO.

**ELECTRIC SOLDERING IRONS**  
FOR ANY CIRCUIT OF  
50 TO 500 VOLTS.

WRITE FOR PRICES

**CHARLES L. CORNELL**  
ELECTRICAL  
ENGINEER.

HAMILTON, OHIO.







CARNEGIE LIBRARY OF PITTSBURGH



3 1812 04298 4725

