

TN

872

I₃A₅₃

STATE OF ILLINOIS
DEPARTMENT OF REGISTRATION AND EDUCATION

DIVISION OF THE
STATE GEOLOGICAL SURVEY

FRANK W. DEWOLF, Chief

BULLETIN No. 40

OIL INVESTIGATIONS IN 1917 AND 1918

Petroleum in Illinois in 1917 and 1918

By N. O. Barrett

Brown County

By Merle L. Nebel

Goodhope and La Harpe Quadrangles

By Merle L. Nebel

Parts of Pike and Adams Counties

By Horace Noble Coryell

Experiments in Water Control in the Flat Rock Pool,
Crawford County

By Fred B. Tough, Samuel H. Williston, and T. E. Savage
In Cooperation with the U. S. Bureau of Mines



PRINTED BY AUTHORITY OF THE STATE OF ILLINOIS

URBANA, ILLINOIS

1919

3 - OCT -
COPY () 1982

90

IMPORTANT

The Illinois State Geological Survey desires to assist the oil industry to the fullest extent. To this end it is desirable that samples of drill cuttings be saved from each screw-depth, for examination by Survey men who are familiar with the strata of the region. Driller's notebooks and sample sacks will be furnished upon request.

STATE GEOLOGICAL SURVEY

Urbana, Illinois

Illinois State Geological Survey

STATE OF ILLINOIS
DEPARTMENT OF REGISTRATION AND EDUCATION

DIVISION OF THE
STATE GEOLOGICAL SURVEY

FRANK W. DEWOLF, Chief

BULLETIN No. 40

OIL INVESTIGATIONS IN 1917 AND 1918

Petroleum in Illinois in 1917 and 1918

By N. O. Barrett

Brown County

By Merle L. Nebel

Goodhope and La Harpe Quadraugles

By Merle L. Nebel

Parts of Pike and Adams Counties

By Horace Noble Coryell

Experiments in Water Control in the Flat Rock Pool,
Crawford County

By Fred B. Tough, Samuel H. Williston, and T. E. Savage
In Cooperation with the U. S. Bureau of Mines



PRINTED BY AUTHORITY OF THE STATE OF ILLINOIS

URBANA, ILLINOIS

1919

TN 872
L 3A 53



SCHNEPP & BARNES, PRINTERS
SPRINGFIELD, ILL.
1919.
21856—3M

RS 20-90

STATE OF ILLINOIS
DEPARTMENT OF REGISTRATION AND EDUCATION
DIVISION OF THE
STATE GEOLOGICAL SURVEY
FRANK W. DeWOLF, *Chief*

Committee of the Board of Natural Resources
and Conservation

FRANCIS W. SHEPARDSON, *Chairman*
Director of Registration and Education

KENDRIC C. BABCOCK
Representing the President of the Uni-
versity of Illinois

ROLLIN D. SALISBURY
Geologist

LETTER OF TRANSMITTAL

STATE GEOLOGICAL SURVEY,
URBANA, JUNE 26, 1919.

*Francis W. Shepardson, Chairman, and Members of the Board of
Natural Resources and Conservation,*

GENTLEMEN :

I submit herewith reports on oil investigations in Illinois in 1917 and 1918, and recommend their publication as Bulletin 40.

Although oil production in Illinois continues to be second only to that of coal, the fields are nevertheless on the decline.

The situation may be met in two ways—discovery of new fields and improvement of methods of oil extraction. The papers on Pike, Brown and Adams counties and the Goodhope and La Harpe quadrangles are contributions along the first line, pointing out areas of favorable structure that merit testing for oil. The final paper describes methods of water control which will help to prolong the life of existing fields and at the same time, it is believed, reduce the cost of extraction.

The discovery of new fields involves considerable uncertainty and risk of capital, as it is impossible to predict the presence of oil in advance; but improvement in methods of well procedure can be confidently expected to react to the benefit of operators, and therefore attention to such problems as are considered in the water-control report is strongly urged.

Very respectfully,

FRANK W. DEWOLF, *Chief.*

CONTENTS

	PAGE
PETROLEUM IN ILLINOIS IN 1917 AND 1918, by N. O. Barrett.....	9
BROWN COUNTY, by Merle L. Nebel.....	21
GOODHOPE AND LA HARPE QUADRANGLES, by Merle L. Nebel.....	51
PARTS OF PIKE AND ADAMS COUNTIES, by Horace Noble Coryell.....	69
EXPERIMENTS IN WATER CONTROL IN THE FLAT ROCK POOL, CRAW- FORD COUNTY, by Fred H. Tough, Samuel H. Williston, and T. E. Savage	97



Fig. 1. Map showing areas covered by the reports.

PETROLEUM IN ILLINOIS IN 1917 AND 1918

By N. O. Barrett

OUTLINE

	PAGE
General review.....	9
Southeastern Illinois.....	12
Cumberland, Coles, Clark, Jasper, and Edgar counties.....	12
Crawford County.....	14
Lawrence County.....	14
Wabash County.....	14
South-central Illinois.....	15
Macoupin County.....	15
Clinton County.....	15
Marion County.....	15
Western Illinois.....	16
Southern Illinois.....	16
Northern Illinois.....	17
Miscellaneous drilling.....	17
Summary tables.....	18

TABLES

1. Illinois oil production, 1905-1918.....	10
2. Fluctuation in prices per barrel of Illinois petroleum, 1916, 1917, and 1918	11
3. Monthly record of wells drilled in Illinois in 1917.....	18
4. Monthly record of wells drilled in Illinois in 1918.....	19
5. County record of wells drilled in Illinois in 1917.....	19
6. County record of wells drilled in Illinois in 1918.....	20

GENERAL REVIEW

In spite of a 73 per cent reduction in 1918 in the number of wells drilled as compared with the number for 1916, production declined only 24 per cent. Table 1 shows the annual production and value from 1905 to 1918 inclusive and figure 18 presents the same data graphically for the State as a whole and for the various pools individually.

As a result of the enormous increase in Kansas' production in 1917 as well as the actual decline that same year in Illinois production, the latter fell in rank from fourth to fifth among oil-producing states. In

1918, with further reduction of the Illinois total and a considerable increase in Louisiana's production, the State fell still another notch lower so far as quantity was concerned. Evidence of the excellence of Illinois oil is found in the fact that in the scale of producing states, Illinois ranked fourth and fifth in value of production during 1917 and 1918 respectively, at the same time that it ranked fifth and sixth in quantity of oil.

The years 1917 and 1918 were characterized by record-breaking prices as a result of war conditions, the rise continuing without inter-

TABLE 1.—*Illinois oil production, 1905-1918*

Year	Barrels	Value
Previous.....	6,576	\$.....
1905.....	181,084	116,561
1906.....	4,379,050	3,274,818
1907.....	24,281,973	16,432,947
1908.....	33,686,238	22,649,561
1909.....	30,898,339	19,788,864
1910.....	33,143,262	19,669,383
1911.....	31,317,038	19,734,339
1912.....	28,601,308	24,332,605
1913.....	23,893,899	30,971,910
1914.....	21,919,749	25,426,179
1915.....	19,041,695	18,655,850
1916.....	17,714,235	29,237,168
1917.....	15,776,860	31,358,069
1918 (preliminary estimate).....	13,365,974	31,230,000

ruption from September 1, 1916 on through to the end of 1918. Changes of prices were infrequent during the latter half of 1917 and all of 1918, as a result of the stabilizing effect of the Fuel Administration upon both production and prices. Table 2 gives the prices per barrel of the two grades of Illinois petroleum for the years 1916, 1917, and 1918.

In 1917 there were but 674 wells completed as compared with 1,469 in 1916, and in 1918 there were only 410 completions. This great decrease obtained in spite of the considerable increase in price—a factor that usually works towards increasing activity—largely because drillers and capital were attracted to the newly discovered and prolific southwestern fields, and partly of course because the more promising unexplored territory in Illinois is becoming continually smaller. With successful completion of the war, return to normal conditions is presumed; indeed, the number of wild cat tests and inside wells contemplated for 1919 is indicative of a general resumption of activity.

It is an interesting fact that for the month of February 1918, less completed work was done in the Illinois field than for any previous month since Hoblitzel and Son started development work on Parker

TABLE 2.—*Fluctuation in prices per barrel of Illinois petroleum, 1916, 1917, and 1918*

Date	1916		1917		1918	
	Illinois	Plymouth	Illinois	Plymouth	Illinois	Plymouth
January 1	\$1.47	\$1.33
January 2	\$1.72	\$1.53
January 3	1.57
January 4	1.63
January 8	1.82	1.73
January 15	1.83
January 21	1.38
January 27	1.62	1.43
January 30	1.87
February 9	\$2.22
February 16	1.72
March 6	1.53
March 13	1.58
March 16	1.82	1.68
March 21	\$2.33
March 28	2.32
April 16	1.92
July 9	2.42
July 28	1.72	1.58
August 1	1.62	1.48
August 3	1.38
August 4	1.52
August 14	1.47	1.18
August 16	2.12	2.03
August 17	1.08
August 28	1.03
September 27	2.13
November 18	1.52
November 30	1.13
December 13	1.57	1.23
December 19	1.62	1.33
December 28	1.43
December 29	1.53
Average	\$1.64	\$1.38	\$1.975	\$1.934	\$2.334	\$2.287

prairie between Casey and Westfield, in Clark County on the Young farm back in 1904. The severity of the weather, characteristic of the winter of 1918, was the immediate cause of this heavy drop in work, though the general decline in activity was also partly responsible.

A feature of the industry in Illinois destined to receive an increasing amount of attention during 1919 is the development and adoption of new and better methods of oil extraction with the idea of prolonging the life of existing fields as well as reducing production costs. The final paper of this bulletin describing the use of mud fluid in water-control work, is a contribution along these lines.

In 1917, of the 674 wells completed, 172 or 25.6 per cent were dry, and 8 or 1.2 per cent were gas wells. The remaining 494 wells (73.2 per cent) reported as producers, yielded a new production of 10,140 barrels, which amounts to an average initial production of 20.6 barrels per well.

In 1918 there were 410 wells drilled, of which 120 or 29.4 per cent were dry, and 14 or 3.4 per cent gas producers. The remaining 276 wells (67.2 per cent) yielded a new production of 5,899 barrels, which amounts to an average initial production of 21.1 barrels.

The number of wells abandoned is gradually increasing, 145 in 1916, 202 in 1917, and 214 in 1918; but these totals are in every case less than the totals of producers brought in for the year in question, which means of course that the number of producing wells in Illinois is still increasing though the rate of increase is gradually lowering.

SOUTHEASTERN ILLINOIS

CUMBERLAND, COLES, CLARK, JASPER, AND EDGAR COUNTIES

In the shallow-sand field of southeastern Illinois 25.3 per cent or 170 of the State's total of 674 completions were drilled in 1917, and 25.1 per cent or 82 of the total of 410 completions were drilled in 1918. Clark County continued to be by far the most active part of this field with 137 completions and a new production averaging 10.5 barrels in 1917, and 71 completions averaging 7.9 barrels in 1918. A few large producers were brought in, the largest for 1917 being Ohio well No. 106 on the N. and K. Young farm in Parker Township, credited with 100 barrels initial production, and the largest for 1918 being Ohio well No. 1 on the C. B. Lee farm in the same township, yielding 60 barrels. The Stock Yards Oil Company made a deep test in Coles County on the Wm. H. Berkley farm, which was probably in Trenton at a depth of 2,400 feet when it was abandoned as dry. It is believed that the sand penetrated in this well at a depth of 2,228 feet may be the equivalent of

the pay sand in the Ohio Oil Company's well No. 29 on the K. and E. Young farm a few miles to the southeast.

In 1918, tests near Oakland in Coles County along the northwest extension of the La Salle anticline resulted in two good gas wells. The test put down by the Women's Federal Oil Company in sec. 30 of East Oakland Township on the Sam Daugherty farm in April, 1918, produced 500,000 cubic feet of gas at 302 feet and another on the Hawkins farm, completed in June, produced 700,000 cubic feet at 315 feet. These wells together were responsible for the interest aroused and still exhibited over oil and gas possibilities in the vicinity of Oakland. Three other wells, all dry, were drilled, two in sec. 32 of East Oakland Township, and a third in southeastern Douglas County.

The area lies a short distance east of the crest of the La Salle anticline, and therefore bears about the same relation to that structure as do the oil fields of Clark, Crawford, and Lawrence counties, for all along the anticline the dip is known to be consistently gentle toward the east. It is, however, not this major structure, but rather interruptions in the general inclination resulting in minor structures on the large fold, which have controlled oil accumulation in the southeastern fields. Terraces and small or local anticlinal structures of the same sort doubtless exist in the Oakland area as well, but whereas drilling has been sufficient to determine the small but all-important structure in the oil fields, drill records about Oakland are so few and outcrops so rare that minor structures are still almost unknown. The problem is further complicated by the fact that such logs as are available indicate considerable irregularity in stratigraphy across the anticline north of Clark County. Indeed, so different are the conditions in Clark County at Westfield from those south of Oakland, that correctness of the correlation of a shallow sand at Westfield with one at Oakland is very doubtful. There are indications that the depth of the heavy Mississippian limestone (the "Big Lime") is much less in Clark County than it is near Oakland, and that there may be sands present near Oakland not found in Clark. The area should be drilled without regard to conditions in Clark County, and the records of the successive wells carefully kept in order to determine the actual sequence of strata. A thorough drilling of one of the persistent coal beds that underlies this region and is apparently of workable thickness, might probably be a venture worth the effort in itself, while at the same time it would reveal the structure in detail and indicate where deeper drillings for oil should most properly be located. Without some such preliminary investigation, prospecting in Coles and Douglas counties must remain essentially a "wildcat" proposition.

CRAWFORD COUNTY

The number of wells drilled fell from 276 in 1917 to 201 in 1918 and the number of producers from 205 to 139, the average new production per well being 8.9 and 8.1 barrels respectively. A 165-barrel well in Robinson Township on the Ferriman farm in 1917 and two 100-barrel wells on the Curtis and Turner farm in Licking Township in 1918 were the big producers of the two years. A number of 50 and 75-barrel wells were drilled during the same period but the majority gave yields considerably smaller.

The activity evinced in Honey Creek Township in 1916 continued on into 1917 and 1918, although in some months Licking and Robinson townships surpassed Honey Creek in number of completions.

LAWRENCE COUNTY

As in the other counties of the southeastern Illinois field, new wells were comparatively few, 133 wells in 1917 and but 71 in 1918, although 246 wells was the total for 1916. The greatest activity was in Dennison Township from which two 200-barrel wells and a number of others almost as large were reported during 1917 and 1918. The Kirkwood and Tracy sands, at a depth of 1,800 feet more or less, gave these large yields.

WABASH COUNTY

The best of a number of good producers brought in during 1917 and 1918 in the Allendale pool were three 100-barrel wells on the Courter lease. The total number of completions fell from 28 in 1917 to 18 in 1918 and the number of producers from 12 to 5, respectively. The average initial production per well for the county was 37.1 barrels in 1917 and 12.3 barrels in 1918.

Excitement over the possibility of the discovery of a pool in Friendsville Township began with the successful completion in October, 1917, of the Midland Oil and Gas Company's well on the Toney farm with an initial production of 40 barrels. The second well on the Toney farm was completed, dry, at 1,650 feet in January and by the following May a third well on the Toney farm and five others on the Price, McNair, Couch, Anderson, and Matheny farms had been reported as dry. A test on the Putnam farm in September of 1918 resulted in another dry well to be added to the list. Further testing will probably be very slow in view of the fact that so large a number of holes were dry in the near vicinity of the producer.

SOUTH-CENTRAL ILLINOIS

MACOUPIN COUNTY

Only three wells were drilled during the past two years in Macoupin County, two of them in 1917 and the other in 1918. The 1918 hole and one of the 1917 wells were drilled on the flank of the Staunton dome but were unsuccessful. The Loveland test drilled in Brushy Mound Township, well up on the southern swell of the Spanish Needle Creek dome,¹ was completed, dry, at 537 feet in February, 1917, and seems to indicate that oil will probably not be found at such depths in the structure, though the possibility of oil from deeper sands is not condemned.

The Staunton gas was substituted for artificial gas at Belleville, Edwardsville, Collinsville, Marysville, and Staunton late in 1916, and its use continued through 1917 and well into 1918, but the field began to show signs of early and rapid exhaustion in the latter part of 1918, necessitating return to artificial gas in some of these towns.

Whether or not production can be revived sufficiently to take care of all or even a part of the area once supplied from this field is a doubtful question, the answer depending on whether the rapid decrease in pressure and flow experienced recently is due to actual exhaustion of the gas or to the ill effects of water caused by indifferent well procedure.

CLINTON COUNTY

In 1917, of the 10 holes drilled, only one, that of the Ohio Oil Company on the Niemeyer farm, was successful, 10 barrels being reported as the initial production at 941 feet. The dry holes were distributed as follows: three in Irishtown Township and one each in Clement, Breese, Meridian, Lake, and Carrigan townships. In 1918, of the 9 holes drilled, four were producers. Three of these were inside wells, two of them having an initial yield of 15 barrels, and one of 3 barrels. The Shaffer well in Irishtown Township, an outside location, gave 2 barrels as its initial yield. The Rogan test also in Irishtown Township resulted in a small production of gas at 1,149 feet.

MARION COUNTY

Marion County's record for 1917 and 1918 is extremely poor, with one gas well and no oil as the outcome of eight tests in the two years.

¹ Lee, Wallace, Oil and Gas in the Gillespie and Mt. Olive quadrangles, Illinois: Ill. State Geol. Survey Bull. 31, p. 102, 1915.

Six tests were in the Centralia-Sandoval area, and two to the northeast in wildcat territory at Alma and at Kimmundy. The latter well was abandoned at 1,918 feet with no showing of oil or sand, although the depth seems sufficient to have reached the Stein and Benoist sands which produce oil at Sandoval.

WESTERN ILLINOIS

The statement made for 1916 may be pertinently repeated for 1917 and 1918, so far as new developments are concerned. The results of wildcat drilling in western Illinois served to emphasize further the "spotty" character of the Hoing oil sand. It is certain that favorable geological structure exists outside the Colmar-Plymouth fields but the prevailing absence of the sand is a discouraging feature.

One 10-barrel well on the MacAllister lease and a number of 5-barrel and smaller wells were completed in the Plymouth-Colmar area. Out of a total of 22 wells drilled there, but 5 were dry and the average initial production was approximately 3 barrels per well in 1917. Activity in 1918 was notably decreased. No wells were reported for Hancock County, and but eleven for McDonough. None was dry, however, and an average initial production of 5.7 barrels is credited to this group.

One dry hole in Schuyler County was the only outside test of which the Survey has record in western Illinois during the two years. It was drilled to a depth of 465 feet and abandoned.

The Pike County field received attention during 1917. This shallow-gas field, discovered in 1886 but not developed to any extent until 1905, has just been investigated by the Survey largely in response to demand of the residents of the area. The interest was roused by the decrease in pressure which has become gradually more apparent in the past few years, as well as by the possibility of finding oil in commercial quantities, and a report on the area is included as a part of this bulletin.

Of the four 1917 wells, three were drilled for oil. The Ohio Oil Company made two tests in New Salem Township, one dry at 616 feet and the other giving a show of oil at 619. Claud Shinn drilled a 634-foot well in Perry Township that showed oil at 650 feet.

SOUTHERN ILLINOIS

Dry holes were drilled in southern Illinois as follows during 1917 and 1918: NE. $\frac{1}{4}$ SW. $\frac{1}{4}$ sec. 35, Elvira Township, Johnson County, depth 2,000 feet; sec. 12, Raleigh Township, Saline County; sec. 28, Eldorado Township, Saline County, depth 1,950 feet; and sec. 32, Omaha Township, Gallatin County. Drilling on the Campbell Hill anticline near

Ava in Jackson County¹ resulted in the discovery of additional gas wells but as yet there has been no commercial utilization of the product.

NORTHERN ILLINOIS

No tests have been made as yet in response to the discovery of a seep of oil and gas along a small fault plane near Coal City, described in a previous bulletin.²

In McLean County two dry holes were put down, one at Downs and the other at Le Roy. Whether or not these holes should be considered as condemning the structure locally is doubtful, owing to the fact that the location of the axis of the La Salle anticline in this area is not known definitely. That it passes northwest in the general vicinity of McLean County, seems clear, but drilling has been so meager and scattered that determination of the axis exactly has been impossible.

MISCELLANEOUS DRILLING

One test credited with an initial production of two barrels and not mentioned above was drilled in Madison County in 1917 on the Keller farm, in sec. 8 of Collinsville Township. Other holes not already noted, all of them dry, were drilled as follows during 1917 and 1918:

1917

<i>County</i>	<i>Township</i>	<i>Section</i>
Bond.....	La Grange.....	21
	La Grange.....	28
	Burgess.....	34
Edwards.....	Shelby.....	35
Fayette.....	Lone Grove.....	12
Madison.....	Saline.....	27
	Omphgent.....	13
	Collinsville.....	8
	Helvetia.....	12
	Hamel.....	10
Morgan.....	Hamel.....	15
	Waverly.....	22
Perry.....	T. 5 S., R. 1 W.....	4
Randolph.....	Sparta (?).....	..
Washington.....	Irvington, 2 holes.....	26

¹ St. Clair, Stuart, The Ava area: Ill. State Geol. Survey Bull. 35, pp. 57-65, 1917.

² Kay, F. H., Petroleum in Illinois in 1916: Ill. State Geol. Survey Bull. 35, pp. 16-17, 1917.

1918

<i>County</i>	<i>Township</i>	<i>County</i>
Cumberland.....	Crooked Creek.....	36
Douglas.....	Sargent.....	35
Madison.....	Olive.....	9
	Olive.....	15
Washington.....	Irvington.....	26

SUMMARY TABLES

The following tables summarize oil development in Illinois during 1917 and 1918. Tables 3 and 4 are compiled directly from the Oil City Derrick. Tables 5 and 6 are compiled from the same source with additions by the author, which accounts for the difference in total. It was impossible to include additions in Tables 3 and 4 because in most cases the month of completion was not known, while for Tables 5 and 6 this information was not necessary.

The total number of wells drilled to January 1, 1918, was 25,997 of which 4,825, or 18.6 per cent, were dry. Similar statistics for January 1, 1919, are 26,407 wells, 4,945 of which, or 18.9 per cent, were dry.

TABLE 3.—*Monthly record of wells drilled in Illinois, 1917*

Month	Completed	New production	Dry holes	Average initial production	Abandoned wells	Gas wells
January.....	66	1,165	14	22.3	11	..
February.....	46	790	17	27.3	12	1
March.....	40	384	13	14.2	14	..
April.....	55	694	13	16.9	15	2
May.....	64	1,020	13	20.8	9	2
June.....	61	1,161	10	23.0	12	..
July.....	73	861	23	16.0	20	1
August.....	72	1,437	15	24.5	15	..
September.....	47	1,091	9	30.3	26	2
October.....	48	672	8	17.2	22	1
November.....	41	509	10	16.4	33	..
December.....	36	354	11	15.9	13	..
Total.....	649	10,138	156	20.9	202	9
1916.....	1,459	24,713	317	22.3	145	36

TABLE 4.—*Monthly record of wells drilled in Illinois, 1918*

Month	Completed	New production	Dry holes	Average initial production	Abandoned wells	Gas wells
January.....	13	248	4	27.6	21	1
February.....	5	11	1	3.7	2	1
March.....	27	308	9	17.2	1	..
April.....	38	378	12	14.5	22	1
May.....	30	454	8	23.7	10	3
June.....	41	470	9	14.7	20	..
July.....	46	978	13	30.6	31	1
August.....	49	676	17	19.2	30	..
September....	38	950	11	35.2	26	1
October.....	25	369	5	19.5	18	..
November.....	42	498	13	11.8	7	1
December.....	42	559	11	13.3	26	..
Total.....	396	5,899	113	19.3	214	9
1917.....	649	10,138	156	20.9	202	9

TABLE 5.—*County record of wells drilled in Illinois, 1917*

County	Completed	New production	Dry holes	Abandoned wells	Gas wells
Bond ^a	3	..	3
Clark.....	137	1,439	21	22	..
Clinton.....	9	10	8	6	..
Coles.....	1	..	1
Crawford.....	276	3,103	71	63	7
Cumberland.....	26	148	1
Edgar.....	6	40	5
Edwards ^a	1	..	1
Fayette ^a	1	..	1
Hancock.....	4	15	1
Jackson ^a	2	..	2
Jasper.....	1	..
Johnson ^a	1	..	1
Lawrence.....	133	4,297	19	93	1
McDonough.....	18	46	4	1	..
McLean ^a	2	..	2
Macoupin ^a	2	..	2
Madison ^a	7	2	6
Marion.....	6	..	5	11	1
Montgomery ^a	1	..	1

TABLE 5.—County record of wells drilled in Illinois, 1917—Concluded

County	Completed	New production	Dry holes	Abandoned wells	Gas wells
Morgan ^a	1	..	1
Perry.....	2	..	2
Pike ^a	4	..	2
Randolph ^a	1	..	1
Saline.....	2	..	2
Wabash.....	28	1,040	16	5	..
Total.....	674	10,140	179	202	9

^a Added by author.

TABLE 6.—County record of wells drilled in Illinois, 1918

County	Completed	New production	Dry holes	Abandoned wells	Gas wells
Clark.....	71	560	11	15	..
Clinton.....	9	35	5	3	1
Coles.....	5	..	4	..	1
Crawford.....	201	2,482	62	96	6
Cumberland.....	1	1
Douglas ^a	1	..	1
Edgar.....	2	6
Jackson ^a	10	..	4	..	6
Jasper.....	3	5	1
Lawrence.....	71	2,601	13	98	..
McDonough.....	11	63
Macoupin ^a	1	..	1
Madison ^a	2	..	2
Marion.....	2	..	2
Wabash.....	18	146	13	2	..
Washington.....	2	..	2
Total.....	410	5,899	121	214	14

^a Added by author.

BROWN COUNTY

By Merle L. Nebel

OUTLINE

	PAGE
Introduction.....	22
Acknowledgments.....	22
Method of field work.....	23
Personnel of party.....	23
Key horizons.....	23
Physiography.....	24
Stratigraphy.....	25
General statement.....	25
Unconsolidated rocks.....	25
Alluvium.....	25
Loess.....	25
Glacial drift.....	26
Consolidated rocks.....	27
General description.....	27
Rocks outcropping in the region.....	28
Carbondale formation.....	28
Pottsville formation.....	30
St. Louis limestone.....	31
Salem limestone.....	32
Warsaw formation.....	36
Keokuk formation.....	37
Rocks known only from drill records.....	38
Burlington limestone.....	38
Kinderhook and Upper Devonian shales.....	38
Devonian limestone.....	38
Niagaran dolomite.....	39
Ordovician rocks.....	39
Possible oil-producing horizons.....	40
Structure.....	41
General statement.....	41
Relation of structure to accumulation of oil.....	43
Detailed structure.....	44
Localities previously tested.....	46
Recommendations.....	49

ILLUSTRATIONS

PLATE	PAGE
1. Map of Brown County, showing structural contours based on the elevation of No. 2 coal above sea level.....	46
FIGURE	
2. Entrenched meanders.....	25
3. Large mass of Pennsylvanian shale and coal imbedded in glacial drift.....	27
4. Nodular limestone.....	30
5. Bluff of Carbondale and Pottsville.....	31
6. Cross-bedding in Salem limestone.....	32
7. Peculiar weathering of argillaceous Salem limestone.....	33
8. Massive brown dolomite (Salem).....	34
9. Contact of Salem dolomite and Warsaw shale.....	35
10. Brown dolomite grading laterally into shale.....	35
11. Local unconformity between Salem and Warsaw.....	36
12. Unconformity between Salem and Warsaw.....	37
13. Diagram, to scale, of unconformity, the left half of which is photographed in figure 12.....	38
14. Diagrams showing conditions governing oil accumulation.....	42

INTRODUCTION

The purpose of this report is to present the results of a survey of Brown County made during the fall of 1917. It attempts to describe briefly the general geology of the region, but the principal object is to point out the rock structure and its relation to possible accumulations of oil or gas. Figure 1 shows the area covered by the report.

ACKNOWLEDGMENTS

Professors T. E. Savage and Stuart Weller of the Geological Survey staff were freely consulted in connection with the correlation of the Salem and St. Louis formations, and their assistance is gratefully acknowledged. Professor Savage in addition gave valuable assistance in reading the manuscript.

The work was begun under the direction of J. L. Rich, who made a preliminary study of the region and selected certain key horizons which could be readily identified and used as a basis for determining the structure. His work covered approximately the northern half of the county, except for a small area worked out by Morse and Rich in 1914.¹ The southern half of the county was worked by the author.

¹Morse, W. C., and Kay, F. H., Area south of the Colmar oil field: Illinois State Geol. Survey Bull. 31, p. 10, 1915.

METHOD OF FIELD WORK

It is known that practically all folding in the area under consideration took place after the deposition of the youngest of the consolidated rocks, and therefore structural deformations of the oil sands are reflected in the hard rocks appearing at the surface. The method of work was based, then, upon the fact that the rock layers at some depth, including all oil-bearing horizons, lie essentially parallel to those outcropping at the surface. Definite beds that could be easily recognized by the geologist were selected as key horizons, and the structure determined by running instrumental levels to each bed.

The field party was composed of a geologist in charge, a transitman, and two rodmen. The geologist identified the key horizons, such as coal beds or limestones, and measured the intervals between them. He selected numerous points, spaced as uniformly as possible, where the key rocks were exposed and at which elevations were later obtained by the transit party under his direction. An early method of marking these points so that they could be recognized by the transit party was to place upon them flags consisting of cheesecloth squares on a lath staff. Each point was located on the map by the pacing and compass method, and a copy of the map furnished to the transitman. So much difficulty was encountered in finding these flags in wooded areas that another method was devised. Instead of placing a flag the geologist carried a hand-level line to some prominent object a few paces away, such as a large blazed tree, a gate post, etc., and carefully described it in his notes. This object was numbered with crayon or paint and the transit party furnished with a copy of the description as well as a copy of the map showing locations of all points. With this method the geologist was enabled to keep his work several weeks in advance of the leveling.

PERSONNEL OF PARTY

The party, in addition to Messrs. Rich and Nebel, included at different times R. Pinheiro, D. D. Sparks, A. H. Thurston, Paul Birmingham, George Burgesser, and William Calvo.

KEY HORIZONS

The principal key horizon used in determining the structure is a thin coal bed known as No. 2 (Colchester) of the Illinois section. It outcrops at numerous points throughout western Illinois, is uniform in thickness, and is easily identified. In areas where this coal does not outcrop other rocks either below or above it were used as key horizons, and the intervals between these rocks and the coal were measured as fre-

quently as possible. The horizons used and the distance between each one and No. 2 coal are as follows:

8. Base of third nodular limestone 125 feet above top of No. 2 coal.
7. Base of *Chonetes* limestone, 112 feet above top of No. 2 coal.
6. Base of second nodular limestone 98 to 102 feet above top of No. 2 coal.
5. Base of shaly, fossiliferous limestone, 20 to 41 feet above top of No. 2 coal.
4. Top of No. 2 coal.
3. Base of first nodular limestone, 9 to 17 feet below top of No. 2 coal.
2. Top of Salem limestone 24 to 50 feet below top of No. 2 coal.
1. Base of Salem limestone 50 to 70 feet below top of No. 2 coal.

As soon as the elevation of any key horizon was determined, the hypothetical elevation of No. 2 coal at that place was computed by adding or subtracting the interval between the two as measured in the nearest exposure.

The top of the Salem limestone is second in importance to the top of No. 2 coal as a key horizon, and was used frequently in the southeastern portion of Brown County. The interval between the two is variable, but by measuring it frequently and using the nearest measurement to a given exposure in computing the hypothetical elevation of the coal, results were obtained which are believed to be reliable.

PHYSIOGRAPHY

Brown County lies on the eastern slope of the divide between the Mississippi and Illinois rivers. The surface of the central and west central portions of the county is a flat, undissected prairie sloping gently to the east. The northern portion is drained by Crooked Creek and its tributaries, the eastern quarter by small creeks flowing directly into Illinois River, and the southern third by McGees Creek, which flows from east to west across the county and empties into the Illinois a few miles below Perry Springs. Timewell is 756 feet above mean sea level, and at the Mount Sterling water tower the altitude falls to 735. At Hersman it is 695, at Gilbirds it is 662, and at Versailles, 588. The flood plain of Illinois River lies at an elevation of about 440 feet above mean sea level, that of Crooked Creek at about 440 to 450, and that of McGees Creek at 450 south of Versailles to 550 south of Siloam. There is a maximum relief of 300 feet, and the county as a whole is hilly and rough except in the central and western portions. The valley sides are usually steep and the flood plains narrow. An interesting example of entrenched meanders (fig. 2) was noted in the SE. $\frac{1}{4}$ sec. 18, T. 2 S., R. 3 W., near the head of a small intermittent stream which flows southeast into McGees Creek.

STRATIGRAPHY

GENERAL STATEMENT

The hard rocks of the region are almost everywhere covered by a mantle of unconsolidated clay, sand, and gravel. These unconsolidated rocks consist of material deposited in the valleys by the present streams, and called *alluvium*, of fine material deposited by the wind, and called *loess*, and of material deposited by the continental glaciers, known as *drift*. The hard rocks are ordinary shales, sandstones, and limestones.

UNCONSOLIDATED ROCKS

ALLUVIUM

The alluvium deposited by the streams consists of fine sand, gravel, and clay which has been washed away from the hills and carried into



Fig. 2. Entrenched meanders. The curved cliff in the center of the photograph is of Salem limestone and is about 20 feet high.

the valleys of such streams as McGees and Crooked creeks and Illinois River. Its greatest thickness is reached in the valleys of Crooked Creek and Illinois River. A deep well drilled near Crooked Creek passed through 210 feet of alluvium before reaching bed rock.

LOESS

The loess is a fine, yellow, wind-blown dust which covers the uplands to a depth of several feet. It is usually thicker along the bluffs overlooking the valleys and thinner back on the uplands. Along the bluffs of Illinois River it is in places as much as 100 feet thick, but over

most of the county is only a few feet thick. Because of this peculiar distribution, it is generally believed that the fine-grained material which forms the loess has been picked up from the flood plains of the larger valleys and spread over the adjacent territory by the wind. A prominent characteristic of loess is its tendency to stand in vertical cliffs where exposed by stream erosion.

GLACIAL DRIFT

The glacial drift underlies the loess, and overlies and conceals the bed rock throughout the region except where it has been cut through by the streams. It consists of a blue or yellow boulder clay (Illinoian till) with occasional layers or beds of sand or gravel. The clay contains numerous boulders or pebbles of many different kinds of rock, usually of the harder varieties, such as granite, diabase, quartzite, limestone, etc., which have been carried great distances by the glacier and deposited with an unsorted mass of sand and clay. Soft rocks, such as shale, have been ground up for the most part into a fine clay, but occasionally a mass of shale like that underlying the glacial drift over much of the county was picked up and moved a short distance by the ice without being greatly broken up. Such a mass is shown in the accompanying photograph (fig. 3). It is about 30 feet long by 15 feet thick and consists of ordinary gray and blue shale with nearly a foot of coal at the base. It is tilted at an angle of about 30° but remains unbroken, although it is completely imbedded in yellow till which is well exposed above and below and on either side. This mass of shale and coal lies below the level of the top of the Salem limestone, which is stratigraphically 25 feet or more below the level of any coal-bearing strata at this locality.

The thickness of the drift averages about 30 to 40 feet over the county as a whole. The greatest thickness is over preglacial lowlands and the maximum noted is 120 feet.

CONSOLIDATED ROCKS

GENERAL DESCRIPTION

The known consolidated rocks underlying this area include all those formations from the lower part of the "Coal Measures" down to the St. Peter sandstone. Only Pennsylvanian and Mississippian rocks outcrop in the county, and include the Carbondale and Pottsville formations of the Pennsylvanian system, and the St. Louis, Salem, Warsaw, and Keokuk formations of the Mississippian system. The rocks lying below the Keokuk are known only from the records of wells which have been drilled through them. Nothing is known of the rocks below the St. Peter sandstone, for no wells have been drilled through it in this region.

Pennsylvanian rocks belonging to the Carbondale and Pottsville formations underlie the drift over about three-fourths of the county, but in places in the southeastern portion they were completely eroded before glacial times, and glacial drift lies directly upon Mississippian limestones.

The accompanying generalized section will give an idea of the character and thickness of the different formations exposed at the sur-



Fig. 3. Large mass of Pennsylvanian shale and coal imbedded in glacial drift in SW. $\frac{1}{4}$ SW. $\frac{1}{4}$ sec. 26, T. 1 S., R. 2. W.

face or explored in deep drilling in this area, and their relations to one another.

Generalized section of hard rocks in Brown County

Pennsylvanian system—

Carbondale formation; consists of shales, sandstones, thin limestones, and No. 5 and No. 2 coals. Upper limit is the top of No. 6 (Herrin) coal which is not present in this area, and lower limit is the base of No. 2 coal. Maximum thickness in Brown County is about 130 feet.

Pottsville formation; soft gray or white clay shale (fire clay), sandstone, and a thin limestone; from the base of No. 2 coal to the top of Mississippian limestone. Thickness variable; 6 to 50 feet.

Mississippian system—

St. Louis limestone; white limestone conglomerate or breccia near top, fine-grained buff or gray dolomite below; much broken and with green shale partings. Thickness 8 to 26 feet.

Salem limestone; green to brown sandstone above and gray or brown granular, fossiliferous limestone below. Both sandstone and limestone were formerly quarried extensively for building stone. Thickness 18 to 35 feet.

Generalized section of hard rocks in Brown County—Concluded

Warsaw formation; gray shales with thin, lenticular limestone beds. Geodes are abundant in the shales, and both limestones and shales are crowded with bryozoan remains. Thickness 30 to 55 feet. Sometimes as much as 80 feet is reported in drill records but this probably includes much of the Salem and Keokuk.

Keokuk limestone; thin-bedded, cherty limestone with abundant fossils. It outcrops in only one locality in Brown County where an exposure 24 feet thick was noted. Normal thickness 40 to 75 feet.

Burlington limestone; white, fossiliferous limestone (crinoidal) with abundant chert. Not exposed in Brown County. The St. Louis, Salem, Warsaw, Keokuk, and Burlington formations where penetrated in drill holes are grouped together and called the "first lime" or "Mississippian limestone". The total thickness of this group as shown in well records is from 325 to 350 feet.

Kinderhook shale; gray shales, not exposed in Brown County and known only from drill records. Thickness 80 to 100 feet. In drill records it is usually not distinguished from the underlying Upper Devonian shale. The two have a thickness of 160 to 200 feet.

Devonian system—

Upper Devonian shale; brown shales with numerous spores of *Sporangites*. Thickness 20 to 100 feet. Not exposed in Brown County and in well records is commonly grouped with Kinderhook shales, the two together having a thickness of 160 to 200 feet.

Devonian limestone; known only in drill records and usually grouped with the Niagaran, the two having a thickness of 10 to 75 feet. In rare cases neither limestone is found.

Silurian system—

Niagaran dolomite; porous limestone or dolomite known only in drill records and grouped with the Hamilton. Thickness 10 to 75 feet. It is in this limestone that the gas of the Pike County gas field occurs. Sometimes a porous sandstone occurs at the base of the Niagaran. This is the rock which produces the oil of the Colmar oil field and is known as the "Hoing sand." When present it varies in thickness from a few inches to 30 feet or more.

Ordovician system—

Maquoketa shale; gray and brown shales, usually 180 to 200 feet thick. Kimmswick-Plattin limestone; gray limestone penetrated only by very deep wells. Usually 200 to 400 feet thick.

St. Peter sandstone; a pure white, clean sandstone, containing large quantities of water. This is the rock which furnishes the water in the deep well at Mount Sterling at a depth of 2,433 feet. Only the deepest wells penetrate it.

ROCKS OUTCROPPING IN THE REGION

CARBONDALE FORMATION

The Carbondale formation consists of gray shales with thin beds of limestone, sandstone and coal. It includes No. 2, No. 5, and No. 6 coals, but in Brown County No. 6 is absent, and No. 5 is rarely found. No. 2

coal is distributed widely over the county from north to south, and its uniform thickness, easy identification, and wide distribution make it by far the best key horizon for determining the structure.

A composite section of this formation, showing its normal character in the north half of the county is as follows:

Generalized section of the Carbondale formation in the north half of Brown County

	Thickness	
	<i>Feet</i>	<i>inches</i>
14. Shale, gray.....	5	..
13. Limestone, white, nodular (key horizon No. 8).....	2	6
12. Shale, gray	11	..
11. Limestone, gray, with <i>Chonetes</i> ? and <i>Spirifer cameratus</i> (key horizon No. 7).....	1	..
10. Shale, gray.....	13	..
9. Limestone, white or light gray, heavy nodular (key horizon No. 6).....	5	..
8. Clay shale, soft, gray or blue.....	6	..
7. Sandstone and sandy shale.....	10	..
6. Shales, blue gray, sandy.....	59	..
5. Limestone, shaly, fossiliferous (key horizon No. 5).....	2	6
4. Clay shales, blue, sandy.....	20	6
3. Limestone, black, septarian.....	1	..
2. Shales, black, bituminous, thin-bedded (black slate)....	3	..
1. No. 2 coal (key horizon No. 4).....	2	..
	141	6

The upper part of this section is found only in the northern half of the county. The heavy nodular limestone (key horizon No. 6) is found as far south as the headwaters of Dry Fork in sec. 18, T. 1 S., R. 3 W., and sec. 13, T. 1 S., R. 4 W. (See figure 4.) The maximum thickness of the Carbondale found south of these points is 60 feet. On the whole, the strata of the Carbondale are very uniform in thickness, although there are local variations. No. 5 coal is absent except in one or two localities. It has been mined in secs. 8 and 9, T. 1 S., R. 3 W., in the valley three-quarters of a mile north of Mount Sterling, where it is 1½ to 3 feet thick and lies 15 to 17 feet above the heavy nodular limestone (key horizon No. 6). The black carbonaceous shale above No. 2 coal varies locally in thickness and in its position above the coal. In the southern half of the county it almost invariably lies directly on the coal, while farther north 3 to 8 feet of blue shale may intervene between the two. This black shale bed, together with the zone of large septarian concretions of black limestone above it, makes the identification of No. 2 coal easy.

POTTSVILLE FORMATION

The Pottsville formation includes all strata from the base of No. 2 coal to the top of the Mississippian limestone. It is made up principally of shale or sandstone with an occasional bed of thin coal or limestone. Its thickness is extremely variable. North and east of Mount Sterling it is in places as much as 50 feet. On the hill at La Grange, near the center of sec. 29, T. 1 S., R. 1 W., the following section was measured:

Section measured near center of sec. 29, T. 1 S., R. 1 W.

	Thickness	
	<i>Feet</i>	<i>inches</i>
14. Drift and loess.....	105	..
13. Shale, sandy	15	..
12. Shale, black, carbonaceous.....	3	6
11. No. 2 coal (key horizon No. 4).....	1	8
10. Shale and underclay.....	7	..
9. Limestone, white, nodular (key horizon No. 3).....	5	..
8. Shale, gray	3	..
7. Shale, sandy	3	..
6. Clay shale, weathers out white.....	9	..
5. Coal	4
4. Sandstone, ferruginous.....	5	..
3. Shales, sandy, and clay.....	9	..
2. Limestone, (St. Louis).....	12	6
1. Dolomite, sandy (Salem) (key horizon No. 2).....	20	6
	199	6



Fig. 4. Nodular limestone near center of sec. 8, T. 1 S., R. 3 W.

The Pottsville here includes members 3 to 10 with a total thickness of 41 feet 4 inches.

South of Mount Sterling and over the southern half of the county the Pottsville is rarely over 15 feet thick, and it consists almost entirely of a soft, white or light-gray clay shale with an occasional lens of sandstone. The shale frequently contains many crystals of gypsum. Along McGees Creek and its tributaries the thickness varies from 7 to 15 feet. (See Fig. 5.) The Pottsville usually lies upon the St. Louis limestone, but in a few instance exposures were found where the St. Louis has been completely eroded and the Pottsville rested directly upon the Salem limestone.



Fig. 5. Bluff of Carbondale and Pottsville in NW. $\frac{1}{4}$ sec. 17, T. 2 S., R. 4 W. Pottsville from base of No. 2 coal (behind man) to St. Louis limestone in creek bed is $7\frac{1}{2}$ feet thick.

ST. LOUIS LIMESTONE

The St. Louis limestone is the youngest formation of the Mississippian system found in this region. It formed an old land surface previous to the deposition of the Pottsville rocks and consequently has been partially, sometimes completely, removed by erosion. The maximum thickness found in this region is 26 feet. The upper part consists of a very characteristic white limestone conglomerate or breccia, and the lower part of poorly bedded, very fine-grained, gray or buff dolomite. It is generally unfossiliferous except for the upper few feet in which the corals *Lithostrotion proliferum* and *Lithostrotion canadense* are in

places abundant. A prominent feature of the St. Louis is the presence of thin stringers and layers of bright-green shale, which varies from a mere parting to two feet thick.

The following section is typical of the more complete exposure of St. Louis in this region:

Measured section of St. Louis formation near center of sec. 16, T. 2 S., R. 4 W.

	Thickness	
	<i>Feet</i>	<i>inches</i>
6. Limestone, light gray, with abundant branching corals (<i>Lithostrotion proliferum</i>).....	3	..
5. Limestone, white, brecciated.....	10	..
4. Shale, green	6
3. Dolomite, broken, light gray.....	1	..
2. Dolomite, fine grained, sandy.....	7	6
1. Shale, green	1	..
	<hr/>	<hr/>
	23	..



Fig. 6. Cross-bedding in Salem limestone, SE. $\frac{1}{4}$ Sec. 8, T. 2 S., R. 3 W.

SALEM LIMESTONE

Underlying the St. Louis limestone, and unconformable with it, is the Salem limestone. This formation is extremely variable in character and may consist of gray, crystalline limestone, of limestone and sandstone, or of a very sandy brown dolomite. In many cases it is extremely difficult to determine an exact line of contact between it and the over-

lying St. Louis, or the underlying Warsaw. Where the gray crystalline limestone occurs it contains numerous fossils and can easily be identified. Following is a list of specimens collected from this horizon in the NE. $\frac{1}{4}$ sec. 24, T. 2 S., R. 4 W. :

Fenestella sp.	Spirifer bifurcatus
Productus altonensis	Spirifer sp.
Echinoconchus biseriatus	Composita trinuclea
Camarotoechia mutata	Aviculopecten talboti
Eumetria verneuilliana	Leperditia carbonaria

Professor T. E. Savage has examined the fossils and confirmed the identification of the limestone as Salem in age.

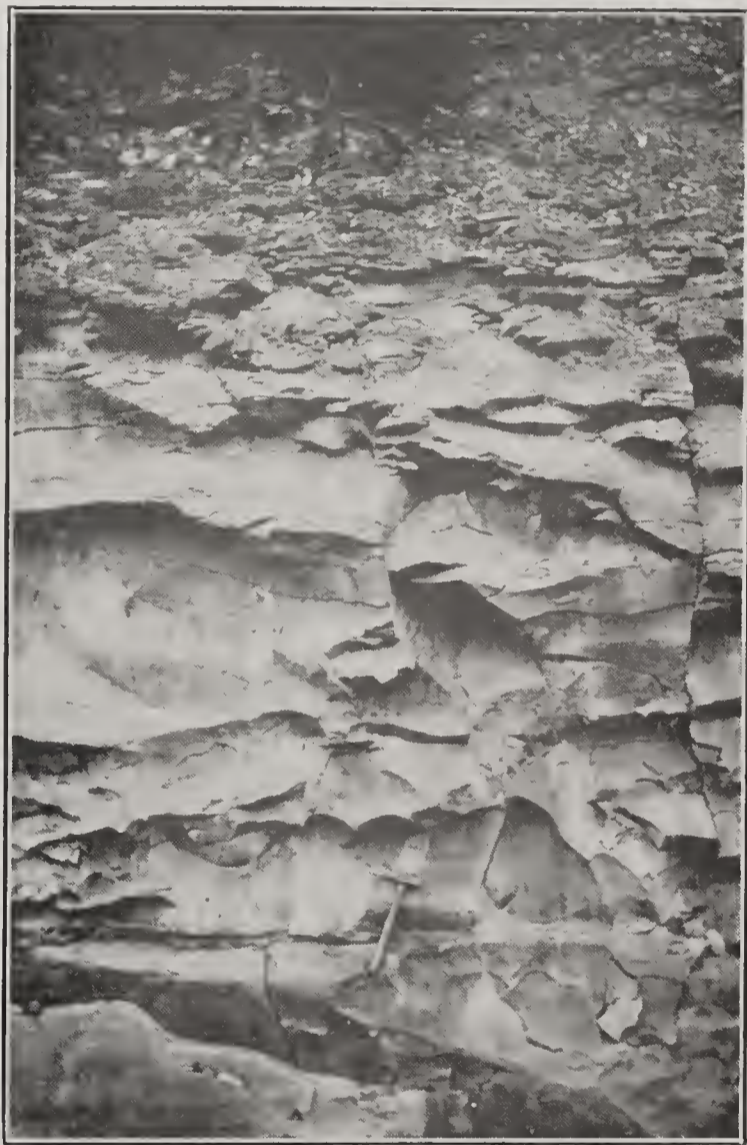

Fig. 7. Peculiar weathering of argillaceous Salem limestone, SW. $\frac{1}{4}$ sec. 23, T. 2 S., R 4 W.

In this phase it closely resembles the well-known Bedford limestone and has an oolitic appearance due to the presence of small rounded shells of the foraminifer, *Endothyra baileyi*. It is nearly always cross-bedded and this cross-bedding is sometimes so perfect that the rock splits into thin, parallel plates. (See figure 6.) The thickness varies from 12 to 30 feet. It is usually sandy near the top and frequently grades upward into a bright green, non-fossiliferous, calcareous sand-

stone which is generally 2 to 5 feet thick, but which may attain a thickness of 12 to 15 feet. When this sandstone is absent the gray limestone lies directly below the St. Louis.

Another phase of the Salem is a soft, gray, argillaceous limestone which in places lies directly below the St. Louis and is from 10 to 15 feet thick. This rock is poorly bedded and weathers in a peculiar man-



Fig. 8. Massive brown dolomite (Salem),
SW. $\frac{1}{4}$ sec. 26, T. 2 S., R. 3 W.

ner. On vertical outcrops it scales off at right angles to the bedding in thin, irregular, curved plates from a few inches to two or three feet across and an inch or less in thickness. (See figure 7.) This is probably a result of frost action.

The lower part of the Salem is usually a massive, brown, sandy dolomite (fig. 8) which may lie in sharp contact with the underlying Warsaw shales (fig. 9) or which may grade so gradually into shale both laterally and vertically that it is impossible to draw a sharp line between the two formations. (See figure 10.) Although most exposures



Fig. 9. Contact of Salem dolomite (above) and Warsaw shale (below), SW. $\frac{1}{4}$ sec. 17, T. 2 S., R. 3 W.



Fig. 10. Brown dolomite grading laterally into shale, NW. $\frac{1}{4}$ sec. 4, T. 3 S., R. 3 W.

indicate continuous deposition from Warsaw to Salem, in one or two cases local unconformities occur between the two. (See figures 11, 12, and 13.)

WARSAW FORMATION

The Warsaw formation, as exposed in this region, consists principally of blue, calcareous or clay shales with thin, lenticular limestones. Both shales and limestones are fossiliferous, bryozoans being especially abundant. The lenticular nature of the limestones is worthy of note, for although a number of such beds occur, they are of small areal extent, and it was found impossible to trace a single bed from place to place so that it might be used in working out structure. Geodes are common in both the shales and the limestones of the Warsaw formation. The maximum thickness noted was 55 feet, but in some of the deep wells 80 feet of shale has been reported. This probably includes a part of the Keokuk formation.



Fig. 11. Local unconformity between Salem and Warsaw. Salem limestone (above) dipping to the right; Warsaw (below) horizontal.

The following section is typical of the Warsaw of this region:

*Measured section of the Warsaw formation along a stream in SE. $\frac{1}{4}$ sec. 18,
T. 2 S., R. 3 W.*

	Thickness	
	<i>Feet</i>	<i>inches</i>
15. Shale, blue, calcareous.....	2	6
14. Clay shale, soft, blue, unfossiliferous.....	6	..
13. Limestone, geodiferous, with abundant fossils.....	1	6
12. Clay shale, blue, full of geodes.....	2	..
11. Clay shale, blue	2	..
10. Limestone, with abundant fossils.....	2	6

Measured section of the Warsaw formation—Concluded

	Thickness	
	<i>Feet</i>	<i>inches</i>
9. Shales, sandy, with thin lenses of limestone, fossiliferous	4	..
8. Clay shales, soft, blue.....	6	..
7. Limestone, sandy, full of fossils.....	..	8
6. Clay shales, soft, blue, with abundant bryozoans.....	2	..
5. Clay shales, soft, blue, free from fossils.....	12	..
4. Geode bed.....	..	6
3. Clay shales, soft, blue.....	4	6
2. Clay shales, blue, alternating with thin, sandy limestone beds	4	..
1. Clay shales, soft, blue, exposed.....	7	..
	57	2



Fig. 12. Unconformity between Salem (above), dipping to the right, and Warsaw (below) horizontal, SE. $\frac{1}{4}$ sec. 19, T. 2 S., R. 3 W.

KEOKUK FORMATION

The Keokuk formation of this region consists of an upper bed of shale which is crowded with geodes for the most part, and a lower member of gray, crystalline limestone with numerous lenses and thin layers of chert. The Warsaw shales lie above the geode beds in perfect conformity with them, and no attempt was made to distinguish between the two in this work. The geode beds outcrop along McGees Creek in the southwestern corner of the county.

The lower limestone member outcrops at only one or two localities near the county line south of Benville, where a maximum thickness of 24 feet was measured. Fossils collected from this limestone were identi-

fied as of Keokuk age by Stuart Weller of the University of Chicago. This limestone is the oldest rock which outcrops in the county. Nothing is known of the rocks lower down in the geological column, except from information obtained in drilling deep wells.

ROCKS KNOWN ONLY FROM DRILL RECORDS

BURLINGTON LIMESTONE

Immediately below the Keokuk limestone is a thick, white limestone containing numerous masses of chert or flint. It is never distinguished from the Keokuk in ordinary drilling operations, but the two are reported together and have a thickness of 200 to 220 feet. They make up the lower part of the "first lime" or "Mississippi lime". Frequently the whole series from the top of the St. Louis to the base of the Burlington is included as the "first lime" and its total thickness is about 325 to 350 feet.

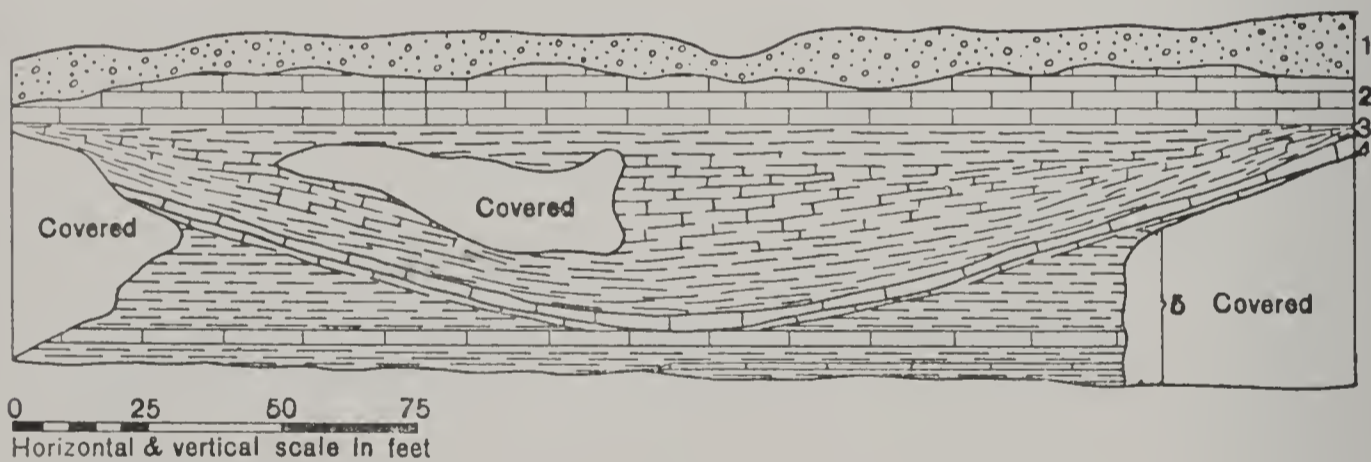

Fig. 13. Diagram to scale, of unconformity, the left half of which is photographed in figure 11.

KINDERHOOK AND UPPER DEVONIAN SHALES

Below the Burlington limestone, and forming the base of the Mississippian system is a thick bed of blue shale, known as the Kinderhook formation. Below it is usually found a brown shale of Upper Devonian age, which contains numerous tiny spores of the plant known as *Sporangites huronense*. The two shale beds are rarely distinguished by drillers, but are reported together with a total thickness of 160 to 200 feet.

DEVONIAN LIMESTONE

A thin, gray, non-magnesian limestone is usually found immediately below the Upper Devonian shales. This is believed to be the late Mid-

dle Devonian limestone of the northwest Illinois and Iowa province. It is rarely more than 15 feet thick. It is difficult to distinguish it from the underlying Niagaran limestone, which, however, is usually a very porous pink dolomite. The two together are reported by drillers as the "second lime."

NIAGARAN DOLOMITE

Below the Devonian limestone is frequently found a very porous, pink or gray dolomite of Silurian age, known as the Niagaran limestone or dolomite. It was deposited upon an irregular, eroded surface and was itself subjected to erosion before the deposition of the overlying Devonian limestone. In places it was completely removed so that the Devonian lies directly upon the Maquoketa shale, but ordinarily a few feet of Niagaran is included in the lower part of the "second lime" as reported by drillers. The greatest thickness reported for the two limestones is 70 feet.

The Niagaran limestone is closely associated with oil and gas production in western Illinois. It is the "gas rock" of the Pike County gas field where wells drilled into it more than 30 years ago are still producing gas sufficient for farm use. Some of the wells in this field reported showings of oil as well as gas, and in one or two wells small quantities of oil have been produced and used for lubricating purposes. The rock is probably capable of acting as a reservoir for oil in commercial quantities, as well as gas. The "broken sand" often reported at the base of the "second lime" by drillers is probably this porous dolomite. The oil-sand of the Colmar oil field, known as the Hoing sand, lies just below the Niagaran dolomite.

ORDOVICIAN ROCKS

Below the Niagaran limestone the drill penetrates a succession of blue, green, and brown shales, called the Maquoketa shale. This formation is from 180 to 200 feet thick. It has not been known to produce oil, but in the Walker well drilled by the Indian Refining Company, near the center of sec. 9, T. 2 N., R. 2 W. (Schuyler County), a showing of oil was reported at a depth of 751 feet, about 74 feet below the top of the Maquoketa shale.

Below the Maquoketa in this region is the Kimmswick-Plattin limestone, generally known as the "Trenton." It is a gray, non-magnesian limestone, and in this region is 200 to 400 feet thick. It is penetrated only by the deepest wells. It is not known to be oil-producing in western Illinois, although a few wells have been drilled into it. In

southeastern Illinois a few deep wells are producing a small amount of oil which is believed to come from the Trenton. In Ohio and Indiana large quantities of oil have been produced from dolomitic areas in the Trenton limestone, and increased production from this horizon may possibly be obtained in Illinois.

Below the Kimmswick-Plattin limestone is the St. Peter sandstone, a clean, white sandstone which usually contains large quantities of water but is not known to be oil producing. The water from the deep well at Mount Sterling comes from this formation at a reported depth of 2,433 feet. The well is said to have been drilled to a depth of 2,675 feet.

POSSIBLE OIL-PRODUCING HORIZONS

Showings of oil or gas have been reported from several different horizons in the rocks which underlie this area, but in western Illinois commercial quantities of oil have been produced from only one such horizon. The oil produced in the Colmar field comes from a porous sandstone lying immediately below the Niagaran dolomite. This is known as the "Hoing sand," and it is this horizon which gives the most promise of producing oil in Brown County. Unfortunately it does not occur as a continuous bed extending throughout the region, but is found only in isolated lenses. This makes prospecting unusually hazardous, since it is impossible to predict in advance of drilling whether or not the sand will be present.

The known areas underlain by this sand vary in extent from 4 or 5 square miles or less up to 40 or 50 square miles. The lens which furnishes most of the production in the Colmar field has an areal extent of about 10 square miles, but most of the production comes from less than half of this area. In general it appears that the sand bodies have a lenticular or oval shape, with their greatest diameter in a northeast-southwest direction. Where two or more lenses are known to lie in close proximity they have a northeast-southwest arrangement. It is still uncertain, however, whether this generalization can safely be used in prospecting. The thickness of the sand bodies varies from a few inches to 30 feet.

The exact age of the Hoing sand has never been determined, but it is certainly early Silurian, and there is some evidence to indicate that it is of early Edgewood age. The shape and distribution of the sand bodies point either to deposition of sand in isolated low areas prior to the deposition of the overlying dolomite, or to extensive erosion after deposition of the sand, so that only isolated patches survived.

Another horizon in which slight amounts of oil have been found is the Niagaran limestone or dolomite. It is very porous and is probably capable of serving as a reservoir for the accumulation of oil, although so far as known, oil has never been found in it in commercial quantities. A well drilled on the Claude Shinn farm, sec. 36, T. 5 S., R. 5 W., penetrated porous Niagaran filled with a heavy, black oil which is almost as viscous as pitch. The Ohio Oil Company reported a heavy black oil from the Niagaran in the Seaborn well in sec. 6, T. 4 S., R. 4 W., Pike County. Gas is frequently reported by drillers, and in the Pike County gas-field wells have been producing from the Niagaran for many years.

Slight showings of oil are occasionally found in the Maquoketa shale, and if a porous sandstone were present to act as a reservoir in which oil could accumulate, it is not unlikely that this formation might become productive, but no such accumulations have been found. In the Walker well, drilled by the Indian Refining Company in sec. 9, T. 2 N., R. 2. W., Schuyler County, oil was reported in the Maquoketa shale at a depth of 751 feet, and about seven gallons of a light, brown oil are said to have been taken out.

STRUCTURE

GENERAL STATEMENT

The rocks in the area covered by this report lie practically horizontal, as far as can be seen by the casual observer. There are a few exposures where the beds are seen to be dipping (figs. 11 and 12), but the dip of such beds is probably due rather to the irregularity of the surface upon which they were deposited, than to any folding or tilting of the rocks since their deposition. However, if a single layer of rock, such as a bed of coal or limestone is traced over large areas, and its elevation above sea level determined at numerous points, it will be found higher at some places than at others. If enough elevations are determined, areas can be located in which the rocks have been arched up into low "anticlines" or "domes." Careful studies have shown that all of the rocks under this region lie approximately parallel to each other, so that if a single bed is found to be arched up, it is safe to assume that the underlying rocks are arched up in the same manner and at the same place. Moreover, it has been shown that the larger part of the folding in this region took place after the deposition of the "Coal Measures" or Pennsylvanian rocks, so that No. 2 coal, for example, is probably folded about as much as the Niagaran limestone or other rocks several hundred feet below. It is true that the region oscillated above and below sea level several times during the deposition of these rocks, and erosion took place during periods of emergence so that the planes of contact between differ-

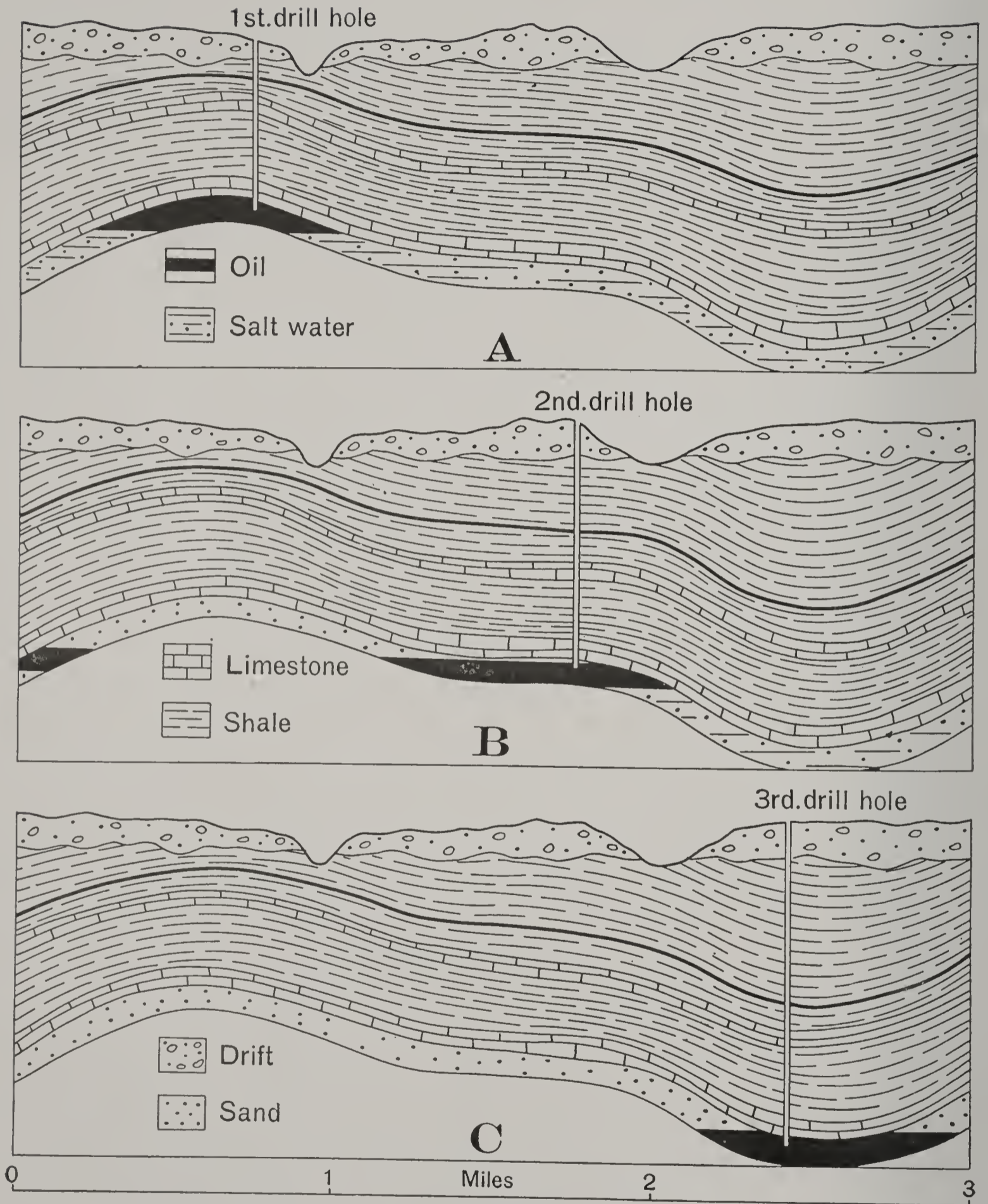

Fig. 14. Diagrams showing conditions governing oil accumulation:

- A. In oil sands saturated with salt water;
- B. In oil sands partly saturated;
- C. In sands containing no water and only partly filled with oil.

ent formation are in many cases quite irregular. The oscillations occurred without much deformation, however, so that each new series of beds was laid down nearly parallel to the beds below. This makes it safe to assume that anticlines existing in rocks at the surface also exist in any oil sands which may occur at some depth.

RELATION OF STRUCTURE TO ACCUMULATION OF OIL

Where oil occurs in the rocks there are three principal factors which govern its accumulation into pools. These factors are: the existence of a porous reservoir, the presence of impervious rocks above and below the porous reservoir, and the favorable rock structure. There are other factors which may apply in certain cases, but in the area under consideration the three enumerated are believed to be the most important.

Previous testing has shown that in places oil occurs in the rocks underlying western Illinois and that where conditions are favorable it has accumulated in commercial quantities. These favorable conditions are the presence of the porous Hoing sand, with the impervious Maquoketa shale below it, and the relatively impervious Silurian or Devonian limestone or Devonian shale above it, and anticlinal or dome structures in the rocks. Most of the oil from the Colmar field has been obtained from a single lens of porous sandstone (the Hoing sand) lying on a structural terrace on the flanks of a large, elongate dome. Other lenses of sandstone higher up on the dome have produced smaller amounts of oil. The rock structure here was an all-important factor in determining the location of accumulations of oil.

In an area where structures such as anticlines or domes are present, the localization of oil accumulations depends upon conditions which can be determined only by drilling, such as the lateral extent of the oil sand and the presence in it of salt water. If the sand underlies only a portion of an anticline or dome, then only that portion can be productive regardless of favorable structures. If the sand contains salt water as well as oil, the two will be arranged in the order of their specific gravities, with the oil above the water. If the sand is completely saturated with the two fluids, the oil will lie in the highest portions of the structure, that is, at the crest of the anticline or dome, while the water will occupy the synclines or basins. (See figure 14A.) If the sand is only partly saturated the water will still occupy the basins with the oil above it on the limbs or slope of the anticlines. If these slopes are flattened at any point, forming a terrace, the oil is very likely to lie on such a terrace. (See figure 14B.) The main productive area in the Colmar field lies on just such a terrace. If there is little or no water in the sand the oil will

occupy the basins. (See figure 14C.) However, in western Illinois as far as is known at present the Hoing sand always contains considerable quantities of water, and oil when present has never been found in the synclines or basins. Extensive testing in the region surrounding the Colmar field has shown the presence of several unconnected bodies of Hoing sand of considerable size, but in most cases they are well filled with salt water. A large area in the vicinity of Littleton in Schuyler County is underlain by Hoing sand and is arched into a well-developed dome. A well drilled almost at the center of the dome found large quantities of water in the sand with only a small showing of oil. Other wells found slight showings of oil, but all found salt water. It is evident that this sand body is completely saturated with salt water together with a very small amount of oil.

Previous experience has shown that prospecting for oil in this region may well be confined to testing of known structures, if the structures can be determined by a study of surface rocks. Taking everything into consideration, it is believed that the first test wells should be located near the crests of the domes and anticlines. If the sand is found to be absent, further testing would not be advisable in the immediate vicinity. If the sand is present but is filled with salt water, further testing down the dip would not be advisable, for the lower portions of the sand are likely to be filled with water also unless a separate sand body is encountered. Just such a condition appears to exist in the Colmar field, however, where the main production is from a sand body on a terrace 60 feet lower than the crest of the dome; yet many wells drilled high up on the dome found large quantities of water in the sand. If a first test reveals a good sand near the top of the structure, but barren of water or oil, other tests should be drilled farther down on the slope, especially on terraces. If a good sand is found on a terrace, but still barren of oil or water, final tests may be drilled in the synclines, where oil is likely to accumulate if the sand contains little or no water.

DETAILED STRUCTURE

The detailed structure was worked out by obtaining the elevation of the seven key horizons described above. The most uniform and most reliable of all these horizons is No. 2 coal, and it was selected as the one most likely to show all details of structure. Its elevation above sea level was determined either by direct leveling or by computation from the elevations of the other key horizons, and a structure-contour map constructed by drawing lines through all points of equal elevation. This map is reproduced in Plate I, and it reveals the structure as follows:

In general the coal dips to the east, but it has a rolling surface upon which are developed small domes, anticlines, terraces, and synclines. The maximum elevation attained is 653 feet in sec. 5, T. 3 S., R. 4 W. (Fairmount Twp.), just over the line in Pike County. The coal in the southwestern portion of Brown County is high, with a decline to the east of 123 feet to an elevation of 530 near Illinois River. In the northwestern portion of the county it is again high, rising to an elevation of 617 in sec. 29, T. 1 N., R. 4 W. (Pea Ridge Twp.), and decreasing to the east to an elevation of 516 in sec. 24, T. 1 N., R. 3 W. (Missouri Twp.). Outcrops are almost lacking in a broad belt across the central portion of the county so that it is impossible to predict the structure in that area.

Covering most of T. 2 S., R. 3 W. (Elkhorn Twp.), and parts of adjoining townships is a broad terrace upon which lie three small domes. The terrace has an elevation of about 580 feet above sea level. A small dome covers most of sec. 6, T. 1 S., R. 4 W. (Lee Twp.), and sec. 1, T. 2 S., R. 4 W. (Buckhorn Twp.) At the apex of the dome in the NE. $\frac{1}{4}$ sec. 6, T. 2 S., R. 3 W. (Elkhorn Twp.), the coal has an elevation of 607 feet and is about 30 feet higher than to the north and east. To the south and west there is only a slight decline.

In sec. 7, 8, 9, 17, and 18, T. 2 S., R. 3 W. (Elkhorn Twp.) is an irregular flat dome upon which the coal lies at an elevation of 600 feet or 30 feet higher than in the area to the north and east.

A broad terrace at an elevation of 580 feet covers most of the southern half of T. 2 S., R. 3 W. (Elkhorn Twp.), with a slight doming in secs. 13, 24, and 25. The apex lies at 596 feet in section 13. To the east the rocks dip off rapidly, so that the apex of the dome rises about 50 feet. To the west there is first a gentle dip, then the rocks rise into a sharp anticline.

Extending almost due north in secs. 16, 17, 20, 21, 32, and 33, T. 2 S., R. 4 W. (Buckhorn Twp.), is a sharp anticlinal nose on which the coal lies 50 to 60 feet higher than to the north, east, and west. The shape of this structure on the south has not been determined, since field work extended only a short distance south of the county line. The highest known point is in the NW. $\frac{1}{4}$ sec. 5, T. 3 S., R. 4 W. (Fairmount Twp.), Pike County, where the coal lies 653 feet above sea level. To the west the coal dips steeply into a narrow syncline, while to the east it slopes gently toward the broad terrace in T. 2 S., R. 3 W. (Elkhorn Twp.) It is possible that additional data in Pike County will modify this structure, and that the coal may rise even higher to the south.

In T. 1 S., R. 2 W. (Cooperstown Twp.), is an area of uplift, but outcrops are very few, in this township, and it is impossible to outline the

structure accurately. The data available suggest a broad dome with its apex in sections 27, 28, 32, 33, and 34, in which the coal lies 20 to 30 feet higher than in the area to the west, and 50 to 60 feet higher than in the area to the east. It slopes off gently to the north and south.

In T. 1 N., R. 4 W. (Pea Ridge Twp.), is a dome with its apex lying in sections 20, 21, 28, and 29, at an elevation of 617 feet. It is 30 feet higher than to the east, south, and west. To the northeast it flattens out into a broad terrace, covering sections 2, 3, 9, 10, 15, and 16 at an elevation of 590 to 600 feet. In sections 13 and 14 of the same township is a slight dome arising about 20 feet above the surrounding territory, and sloping off into a low, narrow anticline to the northeast in secs. 5, 6, 7, and 8, T. 1 N., R. 3 W. (Missouri Twp.)

A narrow strip across the northeast corner of the county, covering parts of Missouri and Ripley townships, was studied in 1914 by Morse and Rich.¹ The structural relations suggested by them have been slightly modified by new data, obtained in the course of the present work, but no important changes need be made. A dome exists in secs. 1, 2, 11, and 12, T. 1 N., R. 3 W. (Missouri Twp.), as indicated by their work, with a large syncline to the southeast. The broad Ripley dome in T. 1 N., R. 2 W. (Woodstock, Schuyler County, and Ripley, Brown County), is best interpreted as a terrace, since the new data indicates that the contour lines do not close around the south end.

A small synclinal basin in secs. 8, 9, 16, and 17, T. 1 S., R. 3 W. (Mt. Sterling Twp.), completes the list of structures brought out by the contour map.

LOCALITIES PREVIOUSLY TESTED

Several attempts have been made to discover oil in the area covered by this report, and five wells have been drilled. The first is said to have been drilled 40 or 50 years ago in sec. 24 or 25, T. 2 S., R. 3 W. (Elkhorn Twp.), by local people, but no data is available as to the depth of the well or the result of the test. The next test well was drilled in 1914 on the J. and L. Parke farm in sec. 25, T. 1 S., R. 2 W. (Coopers-town Twp.), by the Pure Oil Operating Company. No sand was found at the base of the Niagaran limestone, and the well was abandoned. The log of the well is as follows:

¹Morse, Wm. C., and Kay, Fred H., The area south of Colmar oil field: III. State Geol. Survey Bull. 31, pp. 8-36, 1915.

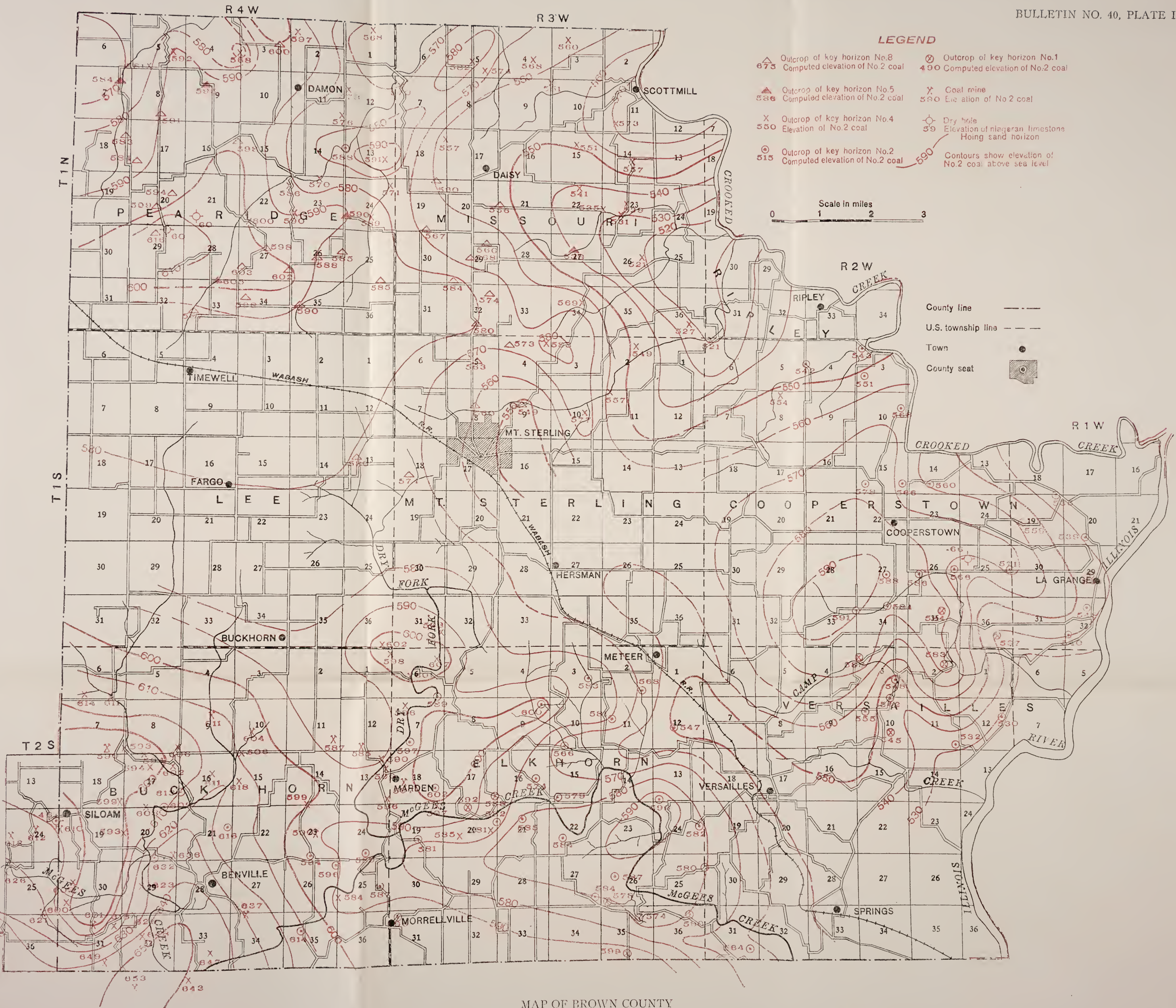

MAP OF BROWN COUNTY
Showing structural contours based on the elevation of No. 2 coal above sea level

Log of J. and L. Parke well, sec. 25 T. 1 S., R. 2 W.

Surface elevation—648 feet

	Thickness <i>Feet</i>	Depth <i>Feet</i>
Sand and gravel (glacial drift).....	125	125
Limestone (Salem)	20	145
Slate and shale (Warsaw and Keokuk).....	80	225
Limestone (Keokuk and Burlington).....	227	452
Slate (Kinderhook and Upper Devonian).....	195	647
Limestone (Devonian and Niagaran).....	67	714
<hr/>		<hr/>
Total depth		714

Another well was drilled in 1914 on the Sale Johnson farm in the NE. 1/4 sec. 24, T. 2 S., R. 5 W., almost on the line between Brown and Adams counties. Here also the sand was absent and the well was dry. The log of this well with formation names inserted in parentheses by the author is reported by Mr. W. E. Lancaster, as follows:

Log of Sale Johnson well, NE. 1/4 sec. 24, T. 2 S., R. 5 W.

Surface elevation—609 feet

	Thickness <i>Feet</i>	Depth <i>Feet</i>
Clay and gravel.....	14	14
Gray lime (strong flow of water) (Salem).....	24	38
Blue shale, with thin streak of shells (Warsaw and Keokuk)	90	128
White lime (strong flow of water) (Keokuk and Burlington)	220	348
Green shale.....	25	373
Blue shale.....	40	413
Brown shale.....	120	533
Gray lime cap rock (Devonian and Niagaran).....	30	563
Blue shale (Maquoketa).....	27	590
Gray shale showing streaks of sand shells (Maquoketa)....	40	630
<hr/>		<hr/>
Total depth.....		630

Following this the Pea Ridge Oil Company drilled two wells (in 1915 and 1916) on the Thomas May farm in secs. 20 and 21, T. 1 N., R. 4 W. (Pea Ridge Twp.) The first was drilled in the N. 1/2 SW. 1/4 section 21 and penetrated two feet of good sand with a slight show of oil, but with much salt water. The second well was drilled about half a mile southwest of the first in the SE. 1/4 section 20 and penetrated 12 feet of sand but was likewise dry. The logs of the two wells are as follows:

Log of May well No. 1, N. ½ SW. ¼ sec. 21, T. 1 N., R. 4 W. (Pea Ridge Twp.)

Elevation—620 feet

	Thickness <i>Feet</i>	Depth <i>Feet</i>
Loam clay, soapstone.....	14	14
Coal (No. 2).....	2	16
Soapstone.....	9	25
Lime shale.....	14	39
Lime rock.....	5	80
Green shale.....	36	75
Lime rock (Salem, Warsaw, Keokuk and Burlington).....	290	370
Green shale.....	140	510
Brown shale.....	15	525
Light shale.....	25	550
Lime rock (Devonian or Niagaran).....	10	560
Sand (Hoing).....	2	562
Gray shale (Maquoketa).....	20½	582½
Total depth.....		582½

Show of oil in the sand, but salt water rose 200 feet in the hole above the sand.

Log of May well No. 2, SE. ¼ sec. 20, T. 1 N., R. 4 W. (Pea Ridge Twp.)

Elevation 635 feet

Dirt and shale to coal.....	18	18
Coal streaked with shale (No. 2).....	8	26
Shale.....	12	38
Lime rock.....	2	40
Hard pan.....	7	47
Lime rock.....	3	50
Broken lime rock.....	8	58
Blue lime rock.....	4	62
Broken lime rock.....	8	70
Solid lime rock.....	20	90
Broken lime rock.....	20	110
Solid lime rock.....	10	120
Broken lime rock.....	20	140
Solid lime rock.....	70	210
Water-bearing lime rock.....	30	240
Solid lime rock.....	150	390
Shale with ore.....	3	393
Gray shale.....	57	450
Shale.....	90	540
Lighter shale.....	13	553
Lime rock (Devonian and Niagaran).....	22	575
Sand (Hoing).....	12	587
Total depth.....		587

RECOMMENDATIONS

Future testing of the localities here mentioned should take into full account the factors previously described which govern the accumulation of oil. Since the oil sand is absent over large areas drilling must be more uncertain than is ordinarily the case, in spite of the existence of favorable geological structures. The shallow depth at which oil may be expected, however, makes drilling comparatively inexpensive and a dry hole does not mean such a loss as in the case of deep drilling. In general, prospecting should be carried out with the principles stated in the section on relation of structure to oil accumulation as a guide.

1. Under ordinary circumstances the dome in secs. 20, 21, 27, 28, and 29, T. 1 N., R. 4 W. (Pea Ridge Twp.), would be recommended for thorough testing. However, both of the wells drilled by the Pea Ridge Oil and Gas Company lie on the structure. No. 2 coal lies 8 feet lower in well No. 1 than in well No. 2, but the elevation of the top of the oil sand is the same in the two wells. These wells show that the oil sand is thickening to the west and south. Since it contained only salt water, any accumulation of oil in the same sand body must lie up the dip. Unfortunately the field data is insufficient to show the structure to the west of these two wells. It is evident that if the coal rises higher it must be to the west or southwest, for it is dipping to the north, east, and south. The chances are good that a well drilled half a mile to a mile southwest of Thomas May No. 2 would penetrate the sand well up the dip.

2. A long terrace lies to the northeast of the May wells, in secs. 11, 12, 13, and 14, T. 1 N., R. 4 W., (Pea Ridge Twp.) and secs. 5, 7, 8, and 18, T. 1 N., R. 3 W. (Missouri Twp.) It is unlikely that the sand body extends very far to the east of May No. 1 since it was there only two feet thick. A successful test on this terrace would depend upon the presence of a sand lens entirely separated from the one to the southwest, and lying at a lower elevation. If the generalization referred to in the section on the relation of structure to accumulation of oil can be relied upon, this terrace should be the logical place to expect to find such a lens. The best location for a test is probably in the east half of sec. 13, T. 1 N., R. 4 W.

3. The dome covering parts of secs. 1, 2, 11, and 12, T. 1 N., R. 3 W., extends east into Schuyler County where it has already been thoroughly tested by three wells of the Ohio Oil Company. No sand was found in any of the three wells, which therefore discredit the dome.

4. There is an elevated area in the southern half of T. 1 S., R. 2 W. (Cooperstown Twp.), which can not be accurately outlined owing to

lack of data. The well drilled in 1914 on the Parke farm is located about $2\frac{1}{2}$ miles northeast of the highest part of this structure, as far as the available data indicates. Since the Parke well failed to find the sand, testing of this structure should remain until the more favorable areas have been prospected. The best location for such a test is in the NE. $\frac{1}{4}$ sec. 33, T. 1 S., R. 2 W.

5. Perhaps the most attractive-looking structure in the county is the broad terrace in T. 2 S., R. 3 W. (Elkhorn Twp.) There have been no wells drilled within 8 or 10 miles except the old well drilled 40 or 50 years ago in section 24 or 25, and concerning which little is known. There is a large area over which the structure is favorable, and if it could be demonstrated that the oil sand is present, very thorough prospecting would be advisable. Since there is no information as to the distribution of the oil sand, the first test should be located on the highest point on the structure which is in the NE. $\frac{1}{4}$ sec. 6, T. 2 S., R. 3 W. Another area almost as high crosses sections 7, 8, 9, 17, and 18. A test of this area might well be located in the S. $\frac{1}{2}$ section 8 or the NW. $\frac{1}{4}$ section 17.

To the southeast of these two areas lies the main portion of the terrace about 20 feet lower, with its general surface at an elevation of 680 feet above sea level. In the SW. $\frac{1}{4}$ section 13, however, it rises to an elevation of 596 feet, then dips rapidly to the north and northeast. An initial test would best be located in the NW. $\frac{1}{4}$ section 24 or the NE. $\frac{1}{4}$ section 23. If early tests on the higher portions of the structure prove unproductive, the broad portion of the terrace in sections 21, 22, 23, 24, 25, 26, and 27 should be tested later.

6. The highest structure in the county and for that reason one of the most favorable, is the anticline in the south half of T. 2 S., R. 4 W. (Buckhorn Twp.), and extending over the line into Pike County. Here No. 2 coal rises more than 50 feet in a distance of only about a mile. On the crest of the anticline it lies at an elevation of 653 feet and slopes off to 600 feet in about a mile to the west, to 590 in about $3\frac{1}{2}$ miles to the east, and to 590 in about 6 miles to the north, thus forming an anticlinal nose to the north. The dry hole drilled on the Sale Johnson farm in 1914 lies almost at the bottom of a syncline, and is about three miles distant from the crest of the anticline. The extension of this structure to the south will no doubt be modified by further mapping, but it has been sufficiently outlined to make testing desirable. At present the best location for a test appears to be in the S. $\frac{1}{2}$ sec. 32, T. 2 S., R. 4 W. (Buckhorn Twp.), Brown County, or the N. $\frac{1}{2}$ sec. 5, T. 3 S., R. 4 W. (Fairmount Twp.), Pike County, and further testing should probably extend to the northeast.

GOODHOPE AND LA HARPE QUADRANGLES

By Merle L. Nebel

OUTLINE

	PAGE
Introduction.....	51
Acknowledgments.....	52
Strata outcropping at the surface.....	52
Strata penetrated in drilling.....	53
Possible oil-bearing horizons.....	59
Relation of accumulation to folds in the oil-bearing bed.....	62
Structure.....	63
General discussion.....	63
Detailed descriptions.....	64
Localities already tested.....	66
Gas in the glacial drift.....	66

ILLUSTRATIONS

PLATES

II. Map of Goodhope quadrangle showing structural contours based upon the elevation of No. 2 coal (red) and upon the elevation of the Burlington limestone (black) above sea level.....	62
III. Map of La Harpe quadrangle showing structural contours based upon the elevation of No. 2 coal (red) and upon the elevation of the Burlington limestone (black) above sea level.....	66

FIGURE

15. Graphic section showing the succession of strata underlying Goodhope and La Harpe quadrangles.....	54
--	----

INTRODUCTION

This report has been prepared in response to numerous requests for information concerning the structure of the area described in relation to possible occurrences of oil or gas, and does not attempt to describe the geology in detail. The latter information will be contained in a more complete report in the course of preparation which will be published later. The field work upon which both reports are based was done in the summer and fall months of 1917.

Although a few wells have been drilled in the area in search for oil, it has by no means been thoroughly prospected. The oil sand from which it is most reasonable to expect to obtain oil, the Hoing sand of the Colmar field, is known to be absent in certain parts of the Goodhope-La Harpe region, and it is probably present only as isolated lenses or

sand bodies in scattered localities. The geologist can not predict the presence of this sand in advance of the drill, and the most that he attempts to do is to eliminate as much of the chance as possible by pointing out areas in which the rocks are arched up into domes or anticlines. Here accumulation can take place if the oil sand and certain other conditions are present, and if water saturation is complete enough to hold the oil or gas in the upward folds. It would be wise to confine testing to areas in which favorable structures have been found, since the natural hazards of prospecting can in that way be reduced. Although no one can guarantee oil at a given location, nevertheless valuable services can be rendered by limiting exploration to small areas.

ACKNOWLEDGMENTS

In his field work in the La Harpe quadrangle and a portion of the Goodhope quadrangle the writer was assisted by Marvin Weller. An introduction to the geology of the region was given by T. E. Savage in a short reconnaissance trip. Information concerning coal and other strata penetrated by wells was freely furnished by most of the residents. The assistance of John W. Coghill, Jr., of Roseville, was especially valuable in this connection.

STRATA OUTCROPPING AT THE SURFACE

In the Goodhope quadrangle only rocks of the Pennsylvanian ("Coal Measures") system outcrop. In the La Harpe quadrangle both Pennsylvanian and the underlying Mississippian rocks are found. A composite section made up from a study of many outcrops, and showing the character and thickness of the various strata is as follows:

Composite section of Pennsylvanian and Mississippian rocks in the Goodhope-La Harpe region

Character of strata	Thickness <i>Feet</i>
Pleistocene and Recent	
Sand, gravel, glacial till (boulder clay) and soil.....	1 to 220
Pennsylvanian system	
Carbondale formation	
Shale, limestone, and coal, to the base of No. 2 coal.....	2 to 85
Pottsville formation	
Shale, sandstone, limestone, and coal (including No. 1 coal) ..	20 to 125
Mississippian system	
St. Louis limestone	
Brecciated limestone and dolomite.....	20 to 35

Composite section of Pennsylvania and Mississippian rocks in the Goodhope-LaHarpe region—Concluded

	Thickness <i>Feet</i>
Salem (Spergen) limestone	
Limestone and calcareous sandstone.....	6 to 12
Warsaw formation	
Shale and limestone.....	30 to 40
Keokuk limestone	
Limestone and chert; only a few feet exposed in the area; normal thickness	50 to 100
Burlington limestone	
Limestone and chert	150 to 200

Of the rocks shown in this section, the Burlington limestone outcrops only in the northern and western portions of the La Harpe quadrangle, and the Keokuk limestone only at a few points in the western portion of the same quadrangle. Rocks of the Warsaw, Salem, and St. Louis formations outcrop only in the southwestern portion of the La Harpe quadrangle. Rocks of the Pottsville and Carbondale formations outcrop in the eastern half of the La Harpe quadrangle and at scattered localities throughout the Goodhope quadrangle.

STRATA PENETRATED IN DRILLING

The strata penetrated in drilling for oil include those known from outcrops, described above, and in addition other strata of the Mississippian system and shales, limestone, and dolomites of the Devonian and Silurian systems which lie above the horizon of the Hoing sand. Immediately below the Burlington limestone is a thick shale bed, known as the Kinderhook shale, which lies at the base of the Mississippian system. It varies in thickness from about 85 to 125 feet. Lying unconformably below it is the Sweetland Creek shale of Upper Devonian age which varies in thickness from 100 to 150 feet. Below this is a gray, non-magnesian limestone of late Middle or Upper Devonian age, usually referred to as the Devonian limestone. It is not always possible in drilling to distinguish it from the underlying Niagaran limestone, but it is known to have a thickness of about 40 to 80 feet or more. Lying unconformably below the Devonian limestone is a porous dolomite of Silurian age usually referred to simply as the Niagaran dolomite. A few wells have been drilled in which this dolomite proved to be entirely missing, but it is usually present in thicknesses varying from 8 or 10 feet to 80 feet or more. The Hoing sand, when present, lies just at the base of this dolomite. Deep wells which may be drilled to test the so-called "Trenton limestone" (Galena-Platteville) will pass through 180 to 200

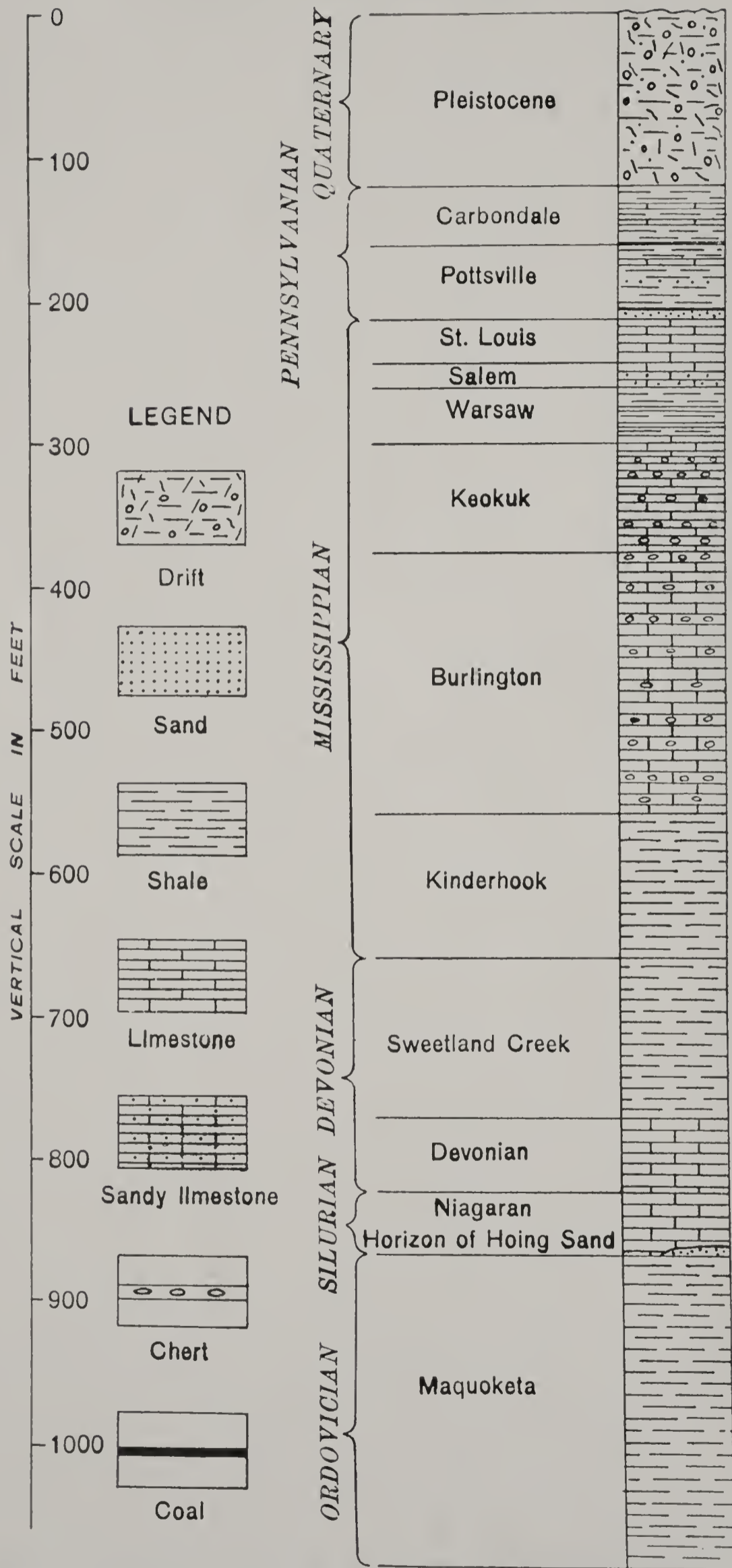

Fig. 15. Graphic section showing the succession of strata underlying Goodhope and LaHarpe quadrangles.

feet of shale below the Niagaran. This is the Maquoketa shale of the Ordovician system.

The detailed succession of strata may be understood best by referring to the accompanying graphic section (fig. 15) and the logs of wells drilled in the area which are given below. Two of these (Stronghurst and Bushnell) are water wells and the other two were drilled in search of oil.

Log of well in the town of Stronghurst in the SE. $\frac{1}{4}$ NW. $\frac{1}{4}$ NE. $\frac{1}{4}$ sec. 25, T. 9 N., R. 5 W., Henderson County

(Interpreted from driller's log by T. E. Savage)

Altitude of surface—665 feet

	Thickness <i>Feet</i>	Depth <i>Feet</i>
Quaternary		
Soil and drift.....	150	150
Kinderhook and Upper Devonian		
Shale, gray	165	315
Devonian and Silurian		
Limestone	105	420
Ordovician		
Maquoketa		
Shale	165	585
Galena-Platteville		
Limestone, gray	200	785
Limestone, brown	15	800
Limestone, gray	60	860
St. Peter		
Sandstone	171	1031
Shale, white	25	1056
Prairie du Chien		
Limestone, white	10	1066
Shale, white	5	1071
Limestone, white	24	1095
Sandstone, white	20	1115
Limestone	50	1165
Shale	5	1170
Limestone	105	1275
Sandstone	5	1280
Limestone	25	1305
Cambrian		
St. Croix or Potsdam		
Sandstone	296	1601

*Log of well in the city of Bushnell, near the center of sec. 33, T. 7 N., R. 1 W.,
McDonough County*

(Compiled from study of drill cuttings compared with driller's log)

Altitude of surface—651 feet

	Thickness <i>Feet</i>	Depth <i>Feet</i>
Quaternary		
Clay, yellow, and loam, black.....	40	40
Clay, blue	60	100
Sand, water	10	110
Pennsylvanian		
Pottsville		
1. Shale, gray.....	20 (?)	130
Mississippian and Upper Devonian		
Warsaw		
2. Shale, gray.....	6 (?)	136
Keokuk-Burlington		
3. Limestone, white, fragments of chert numerous; frag- ment of crinoid stem noted.....	50	186
4. Same, with crystals of calcite.....	66	252
5. Limestone, white to light gray, cherty, with numer- ous crinoid stems and crystals of calcite.....	78	320
6. Same, with rounded quartz pebbles and basic igneous pebbles from the surface.....	15	335
7. Chert, white, with some limestone and calcite; crin- oid stem noted	35	370
Kinderhook and Devonian		
8. Shale, blue-green, fine texture, thin beds, with an occasional fragment of chert, pyritiferous.....	39	409
9. Same	31	440
10. Shale, dark brown, hard, thin bedded, micaceous, highly bituminous. When thoroughly ignited will burn	170	610
11. Shale, gray-green, fine texture, thin bedded, not cal- careous	20	630
Silurian		
Niagaran		
12. Limestone, gray, very argillaceous, soft, containing fragments of brachiopod shells.....	20	650
13. Limestone, gray, powdered by drill; slightly argil- laceous	30	680
14. Limestone, with a few fragments of gray-green shale; numerous crinoid stems.....	15	695
15. Limestone, like the last with some chert and iron rust; fragments of brachiopod shells noted.....	15	710
16. Dolomite, straw colored, finely crystalline with al- most an equal amount of minute fragments of white chert. Some steel gray shale, small crystals of pyrite, and an occasional quartz grain present	15	725

Log of well in the city of Bushnell—Concluded

	Thickness <i>Fcet</i>	Depth <i>Feet</i>
17. Dolomite, white, finely crystalline, powdered, with very fine fragments of white chert; few sand grains	7	732
18. Sand, white, dolomitic, pyritiferous, sand grains slightly rounded, clear quartz, some shale present	8	740
Ordovician		
Maquoketa		
19. Shale, grayish-green, fine texture.....	7	747
20. Shale, brownish-gray, with a small amount of gray, fine grained, dolomite	38	785
21. Shale, dark gray, fine grained, thin bedded, arenaceous, with gray dolomite.....	36	821
22. Shale and dolomite, like the preceding. This sample was labeled by the driller "888 to 892 notice in particular". There is however, nothing exceptional about the sample.....	71	892
23. Sandstone, gray, argillaceous, dolomitic, very fine grained, some pieces of chert and coal.....	11	903
Galena-Platteville		
24. Dolomite, dark straw color, fine grained; powdered by drill. Very little reaction with cold dilute acid which becomes brisk when heated.....	17	920
25. Same	63	983
26. Same only somewhat lighter in color.....	57	1040
27. Same	30	1070
28. Same	30	1100
29. Dolomite, light brown, fine grained, with some very small bits of dark shale.....	40	1140
St. Peter		
30. Sandstone, white, with medium sized rounded, clear, quartz grains. Cement dolomitic.....	160	1300
31. Sandstone, flesh color, very fine grained. Cement dolomitic	50	1350

*Log of Parrish well in NW. ¼ NW. ¼ sec. 34, T. 9 N., R. 3 W., (Ellison Twp.)
Warren County*

Altitude of surface—752 feet

	Thickness <i>Fect</i>	Depth <i>Feet</i>
Quaternary		
Soil and clay (probably loess).....	25	25
Clay, blue	10	35
Shale or clay.....	5	40
Sand	2	42
Pennsylvanian		
Pottsville		
Shale	28	70

Log of Parrish well—Concluded

	Thickness	Depth
	<i>Feet</i>	<i>Feet</i>
Sand	4	74
Shale, blue	36	110
Limestone	6	116
Shale, blue	46	162
Limestone	2	164
Shale	5	169
Mississippian		
Burlington		
Limestone	20	189
Shale	2	191
Limestone	131	322
Kinderhook		
Shale, light.....	118	440
Devonian		
Upper Devonian (Sweetland Creek)		
Shale, brown to black.....	10	450
Shale, drab with spores of <i>Sporangites huronense</i>	105	555
Devonian and Silurian		
Limestone, gray, dolomitic.....	10	565
Limestone, gray, non-dolomitic.....	35	600
Limestone, dark.....	20	620
Dolomite, gray	42	662
Ordovician		
Maquoketa		
Shale, light	12	674

Log of Gochenour well near center NE. ¼ sec. 3, T. 6 N., R. 5 W., (Fountain Green Twp.) Hancock County

(Compiled from study of drill cuttings and driller's log)

Altitude of surface—660 feet

	Thickness	Depth
	<i>Feet</i>	<i>Feet</i>
Quaternary		
Soil, clay and gravel.....	30	30
Mississippian		
St. Louis, Salem, and Warsaw		
Limestone and shale.....	85	115
Keokuk and Burlington		
Limestone, leached, with chert fragments.....	45	160
Limestone, white, crystalline, with much chert.....	90	250
Limestone, white, crystalline, with little chert.....	75	325
Limestone, with some greenish shale.....	30	355
Kinderhook		
Shale, greenish to gray.....	45	400
Shale, greenish to gray, crystalline.....	80	480

Log of Gochenour well—Concluded

Devonian

Upper Devonian (Sweetland Creek)

Shale, greenish, with dark fragments, the latter containing numerous spores of <i>Sporangites huronense</i>	100	580
---	-----	-----

Devonian and Silurian

Dolomite and limestone, gray, subcrystalline, with pyrite	40	620
Limestone, gray, with chert fragments, mostly fine grained	110	730
Dolomite, gray to drab, with small quartz sand grains..	15	745

Ordovician

Maquoketa

Shale, bluish gray.....	10	755
-------------------------	----	-----

POSSIBLE OIL-BEARING HORIZONS

There are four possible oil-bearing horizons in the rocks underlying the Goodhope-La Harpe region. These are, in order of depth, the Pottsville sandstone, the Niagaran dolomite (Silurian), the Hoing sand (at base of Niagaran), and the Galena-Platteville limestone or dolomite.

Large quantities of oil have been produced from Pottsville sandstones in the northern part of the main oil fields in the southeastern part of the State. There, however, the Pottsville formation is thick and contains thick sandstone beds which are persistent over comparatively large areas. In the Goodhope-La Harpe region thick sandstones in the Pottsville are the exception rather than the rule. The thickest known is that which outcrops on Cedar Creek at the northeast corner of the Goodhope quadrangle, where it has a maximum thickness of about 30 feet. Thicknesses of 50 to 75 feet are reported in some wells, but undoubtedly include a considerable thickness of shale. There has been no production of oil from the Pottsville from western Illinois, but oil is reported to have been encountered in a few wells drilled into it in search for water. Mr. John Anderson states that a well was drilled on his farm near the NW. corner SW. $\frac{1}{4}$ sec. 12, T. 8 N. R. 2 W. (Swan Twp.), Warren County, in which a thick black oil was encountered in sandstone at a depth of 75 or 80 feet (top of sandstone at 35 feet). A quantity estimated at several barrels is said to have flowed out of the well, but this was finally cased off, and fresh water struck at 90 feet. Two wells drilled in secs. 17 and 18, T. 9 N., R. 3 W. (Ellison Twp.), Warren County, are said to have encountered oil at depths of 120 and 100 feet, respectively. However, no considerable production of oil is to be expected from the Pottsville sandstone in this region, owing to its shallow depth, its small lateral extent, and the fact that it outcrops at numerous places, both at the surface and under the glacial drift. Pottsville rocks underlie all of the Goodhope quadrangle and approximately the eastern half of the La Harpe

quadrangle, but it is very unlikely that sandstones are present in the Pottsville under all of this area.

The Niagaran dolomite is very porous and frequently contains small quantities of gas and oil, but has never furnished oil in commercial quantities. Gas has been produced from the Niagaran in the Pike County field for many years, and small amounts of heavy, black oil have been reported in the same area. Throughout western Illinois gas is frequently encountered in wells which penetrate the Niagaran. In Henderson County, in the vicinity of Media, gas and showings of oil were encountered in several wells, although no production has been secured. A rather unusual feature of these wells is that the gas and oil seem to lie in the upper part of the "second lime"; that is, in the Devonian limestone, rather than the Niagaran dolomite. The data are insufficient to determine the horizon exactly, however. Neither the Devonian limestone nor the Niagaran dolomite are considered so promising for oil production as is the Hoing sand.

The Hoing sand is not a continuous bed, but consists of isolated lenses of a porous, white sandstone which occur at the base of the Niagaran dolomite, and immediately overlying the Maquoketa shale. Prospecting for oil in this sand is therefore unusually hazardous, since the presence of the sand can not be predicted in advance of drilling. It is probably absent over a considerable portion of the Goodhope-La Harpe area, and a search for oil must therefore in large part consist in a search for bodies of the sand. There are only two localities in which the sand is known to occur. One of these is the vicinity of Bushnell in the southeastern portion of the Goodhope quadrangle. In the new city well there, drilled in 1915 the driller reported about 15 feet of sandstone at the base of the Niagaran dolomite. Samples of drill cuttings from the well were examined by members of the Survey staff and show that such a sandstone is present. The lower eight feet consists of white, quartz sand, and the seven feet above this contains a considerable proportion of sand. The second locality in which sand was reported at the base of the Niagaran is southeast of La Harpe in the southwestern portion of the La Harpe quadrangle. Samples of the drill cuttings from a well drilled on the Gochenour farm in the NE. $\frac{1}{4}$ sec. 3, T. 6 N., R. 5 W. (Fountain Green Twp.), Hancock County, were examined at the Survey office, and it was found that the basal 15 feet of the Niagaran dolomite contained a considerable amount of quartz sand grains. Another well was drilled on the Gills farm in sec. 8, T. 6 N., R. 3 W. (Emmet Twp.), and although no log of the well is available, Mr. Gills reports that about 20 feet of sand was found at the base of the Niagaran,

with a showing of gas. It is impossible to state whether this was a clean quartz sand, or the ground-up bits of dolomite which are easily confused with the quartz sand. Another well in the SW. $\frac{1}{4}$ NW. $\frac{1}{4}$ sec. 18, T. 6 N., R. 2 W. (Macomb Twp.), reported four feet of good sand with a showing of oil.

Although a well may penetrate to the Maquoketa shale without finding the Hoing sand, it does not necessarily discredit the territory immediately surrounding it, for the known lenses of sand are small in areal extent and one of two adjoining wells may find a good sand and the other miss it entirely. There are numerous instances of this sort in the Colmar pool, where two or more separate lenses occur cutting across the Colmar dome and the Lamoine terrace.¹ Therefore an area where the rock structure is favorable for the accumulation of oil or gas can not be thoroughly tested and condemned on the basis of absence of the sand in a single well. Sufficient drilling must be done to demonstrate the general absence of the sand throughout the favorable area before the structure can be said to be fairly tested.

There are two possible oil-producing horizons below the Hoing sand, but neither is regarded as likely to be productive in this region. The first is the Maquoketa shale, in which showings of oil have been reported in western Illinois. In the Indian Refining Company's well on the Walker farm in sec. 9, T. 2 N., R. 2 W. (Buena Vista Twp.), Schuyler County, oil was reported at a depth of 751 feet, about 74 feet below the top of the Maquoketa, and several gallons are said to have been taken from the well. The second horizon below the Hoing sand which might prove productive is the Galena-Platteville limestone below the Maquoketa. This rock is frequently dolomitic and porous, and showings of oil have been reported from it. It occupies about the same position in the geological column as the so-called "Trenton" of southeastern Illinois from which a small quantity of oil is being produced. The Trenton limestone of Ohio and Indiana has been the source of large quantities of oil. There is no assurance that this horizon will prove productive in western Illinois, but an occasional well should be drilled through it where the geologic structure is favorable, in order to test the region thoroughly. It is the oldest known rock in this area in which any oil may reasonably be expected, and since it can be reached at a depth of not over 1,000 feet, testing should be relatively simple and inexpensive.

¹ Kay, F. H., and Morse, W. C., The Colmar oil field: Ill. State Geol. Survey Bull. 31, pp. 42-43.

RELATION OF ACCUMULATION TO FOLDS IN THE OIL-BEARING BED

Thorough studies of oil and gas occurrence throughout the world have demonstrated beyond question the importance of rock structure in determining the accumulation of these substances. Although one can by no means state that all oil occurs in anticlines or domes, previous experience and careful studies of known oil pools in Illinois have shown that the proper conditions for accumulation in the area under discussion are most likely to be met with at the crests of folds such as anticlines or domes, and that such places should be tested first in new territory.

There are three principal conditions governing accumulation. They are as follows:

1. The presence of a porous bed, such as a sandstone or cavernous limestone to serve as a reservoir.
2. An impervious cover, such as shale or other fine grained rock to prevent the escape of the oil or gas.
3. Folding in the rocks by which are produced dips along which the oil and gas can migrate and segregate into pools.

The first condition may be met in this region by any one of the beds described above under the heading "Possible oil-bearing horizons." The second is met by the Maquoketa shale lying above the Galena-Platteville limestone, the Kinderhook and Upper Devonian shales above the Niagaran dolomite and the Hoing sand, and the Pennsylvanian shales above the Pottsville sandstone. The third condition, that of folding to produce favorable geological structure, is met at certain localities, and it is the purpose of this report to point out the areas in which favorable structures exist.

The accumulation of oil in a given structure is to a considerable degree dependent upon the presence and amount of salt water in the sand. The productive oil fields of Illinois are in the main surrounded by barren areas in which the sand contains salt water. Where the sand is saturated, the oil lies near the crest of the anticlines or domes, with the gas, if any, above it (fig. 14 A). Where the sand is only partly saturated the oil lies farther down the sides of the folds, at the upper surface of the water, and the crests may be dry (fig. 14 B). A rather common mode of occurrence is on flattened terraces on the sides of a fold such as is shown in figure 14 B. If water is absent from the sand, the oil may occur in the troughs or synclines (fig. 14 C). This mode of occurrence is comparatively rare and prospecting should be confined to the domes, anticlines and terraces, unless it is demonstrated that the sands contain no water.

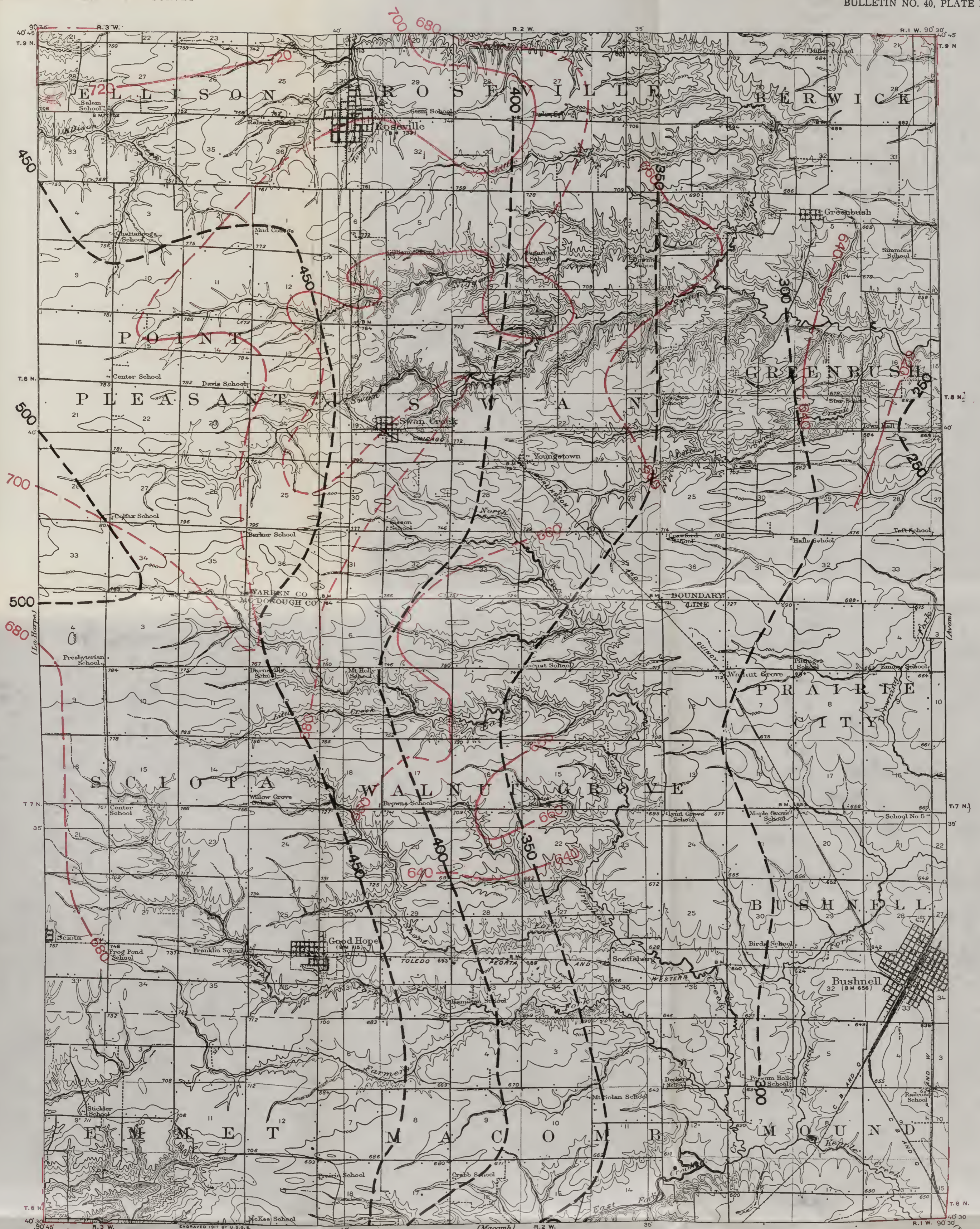

MAP OF GOODHOPE QUADRANGLE

Showing structural contours based upon the elevation of No. 2 coal (red) and upon the elevation of the Burlington limestone (black) above sea level

DESCRIPTION OF MAP

The heavy black lines show the position of the base of the Burlington limestone above sea level, and are to be considered apart from the fine black lines which represent the surface of the region. The reader is requested to imagine that the Burlington limestone and the beds that overlie it are removed so that the upper surface of the underlying Kinderhook is exposed, and that the area is invaded by a sea three hundred feet above present sea level. The 300-foot black contour line would be the shore line at this stage, but if the level of the sea would rise 50 feet the shore line would creep to the position of the 350-foot contour, and similarly with each 50 foot rise the shore line would advance to the next higher contour line. Thus the surface of the base of the Burlington or the top of the Kinderhook south and east of Stronghurst is high and would remain above water until the water raised to almost 600 feet. The general dip of the beds is toward the east and south, veering to west in the southwest part of the quadrangle.

In a similar manner the red contour lines show the position of No. 2 coal above sea level and the reader may follow a method in picturing its surface similar to the method just described for the Burlington limestone.

SPECIAL NOTICE

It is impossible to predict the presence of oil in any given area. The fact that the Hoing oil sand is present at only comparatively few places adds an additional element of uncertainty in the western counties of Illinois. Since in most fields the oil accumulates where the sand has been folded upward, and since the downward folds or synclines are usually filled with salt water, a map which shows the position of the beds previous to drilling is very valuable. The operator can then confine his tests to territory where accumulations would take place if the other conditions were favorable. Thus one element of chance is eliminated.

W.H. Herron, Acting Chief Geographer.
Glenn S. Smith, Topographic Engineer in charge.
Topography by C.W. Goodlove.
Control by E.L. McNair, C.B. Kendall, and R.G. Clinite.
Surveyed in 1916.

Scale 1:50,000
4 Miles
Kilometers

TRUE NORTH
MAGNETIC NORTH
APPROXIMATE MEAN
DECLINATION, 1918
Edition of 1918

Contour interval 20 feet.
Datum is mean sea level.

ILLINOIS STATE GEOLOGICAL SURVEY

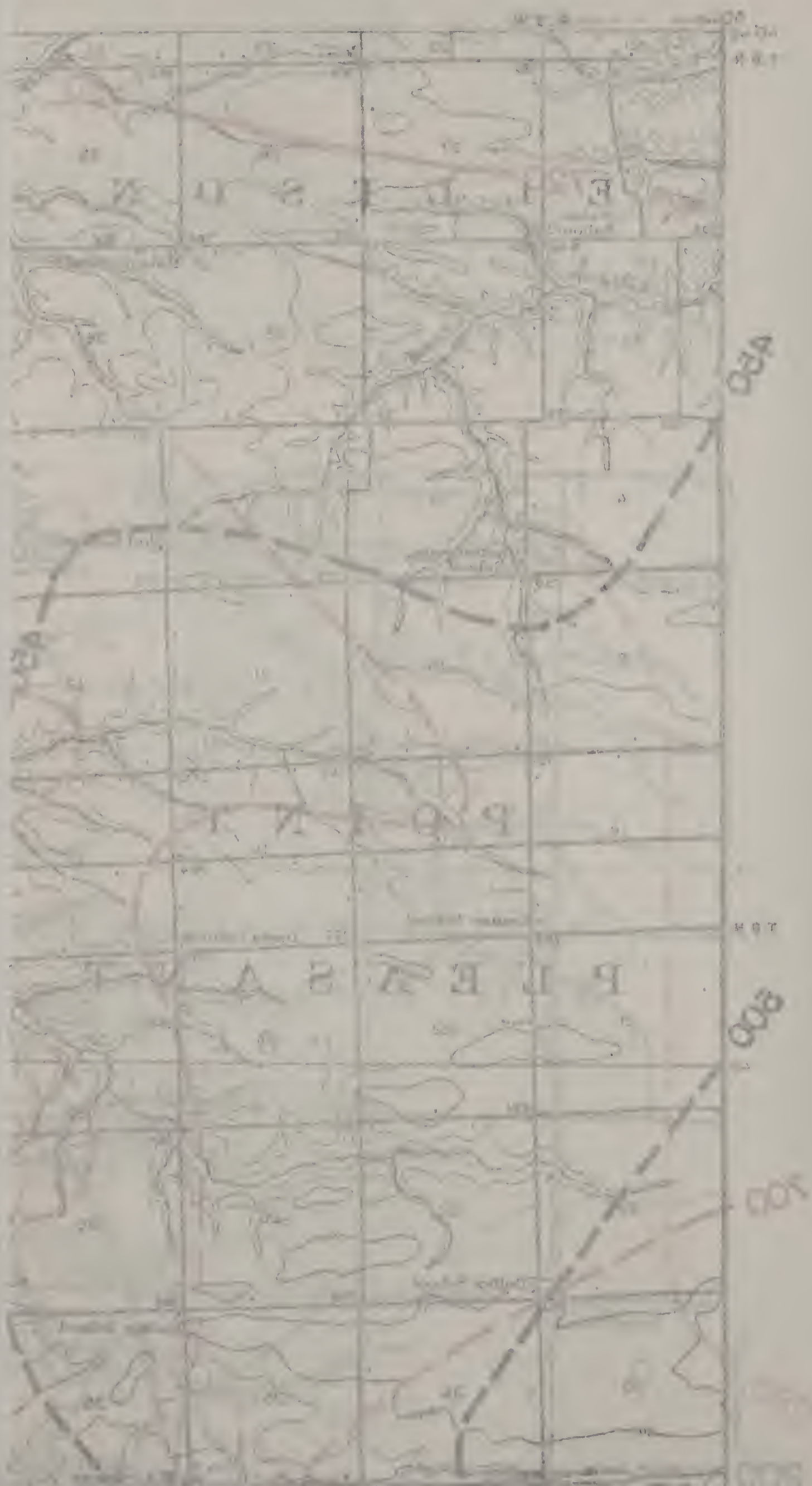

STRUCTURE

GENERAL DISCUSSION

The geologic structure of a given area can be determined best by a study of rock outcrops supplemented by information obtained from well logs. If a definite bed outcrops over large areas and can be readily identified and traced from place to place it is a comparatively simple matter to determine its altitude above sea level at numerous localities. If the same bed can be recognized in well logs, its altitude can be obtained over considerable areas in which it does not outcrop. In the Goodhope-La Harpe area No. 2 coal is just such a "key" bed. Its altitude has been determined at numerous points in the area which it underlies and structural contour maps have been prepared by drawing lines through points of equal elevation. (See Plates II and III, red contours.) If it can be assumed that the key bed lies parallel to the oil sands several hundred feet below, then the structure shown by that bed can be said to represent faithfully the structure of the oil sands. However, this is not strictly true for the area under consideration, as is shown by the following discussion.

The greater portion of the State of Illinois occupies a large structural basin or syncline with its western border roughly parallel to the Mississippi River.¹ Superimposed upon this large synclinal structure are numerous small structures such as anticlines, domes, terraces, and synclines. Over this large basin structural disturbances took place in the intervals between the deposition of successive formations, and the beds now exposed at the surface do not necessarily show structure parallel to that of the underlying rocks. This is best brought out by a study of some deeply buried bed or horizon which can be recognized in well logs. In the Goodhope-La Harpe area the most satisfactory horizon for this purpose is the base of the Burlington limestone. Accordingly the altitude of this key horizon was determined wherever wells could be found which penetrated deeply enough, and structural contour maps were constructed just as in the case of the coal. The only difference is that the points are fewer and are more widely scattered, so that the structure is necessarily generalized, and small details are not shown. This structure is shown by black contours on the maps (Plates II and III).

A careful study of the two sets of contours demonstrates the lack of parallelism between the two key horizons. They both have the same general direction of dip, namely, to the east and south toward the center of the large Illinois basin, but the Burlington limestone dips much more

¹ A Geologic Map of Illinois: State Geol. Survey, 1917.

steeply. At a point near the center of the west edge of the Goodhope quadrangle the base of the Burlington limestone lies at an elevation of about 500 feet, while near the center of the east edge of the same quadrangle, 12 miles away, it has an elevation of only 235 feet. The decrease amounts to 265 feet, or 22 feet per mile, while the elevation of No. 2 coal decreases only about 87 feet in the same distance, or $7\frac{1}{4}$ feet per mile. In the La Harpe quadrangle the elevation of the base of the Burlington limestone decreases 170 feet from the central to the southern portion, while the elevation of No. 2 coal decreases only 71 feet in the same distance.

The ideal key horizon to determine structure which may be used in prospecting for oil is the upper surface of the oil sand itself. Lacking sufficient data concerning the sand, the next best key horizon is that approaching nearest to the oil sand in depth. In the Goodhope-La Harpe area this is the base of the Burlington limestone, and the structure shown by this horizon should be considered first in selecting locations for drilling. This may be supplemented by testing the structures shown by the coal if the divergence between the two horizons is taken into account. The effect of this divergence as the depth increases is to displace the apex of the structure in the direction in which the interval between the beds is increasing. Therefore a test well in order to strike the oil sand at the apex of a dome must not be drilled at the apex indicated by the coal structure, but to one side or the other. The proper place to test the structures shown by the coal in this area is pointed out in the description of individual structures which follows.

DETAILED DESCRIPTIONS

The principal structural feature shown by the contours on the base of the Burlington limestone is a dome covering a large area in the north half of the La Harpe Quadrangle. The apex lies near Stronghurst, where the Burlington rises to an altitude of 603 feet. To the west it appears to have a steep dip to an elevation of 390 feet, but this is based upon the log of one well in the SW. $\frac{1}{4}$ of sec. 28, T. 9 N., R. 5 W. (Stronghurst Twp.), which passed through limestone from 90 to 250 feet. If this is the Burlington limestone, as the driller called it, its base lies at an elevation of about 390 feet. To the south of Stronghurst the limestone dips off fairly uniformly to an elevation of 300 feet south of La Harpe. To the east it has a gentle dip across the La Harpe quadrangle, which becomes steeper from west to east across the Goodhope quadrangle and reaches a minimum elevation of 235 feet in sec. 22, T. 8 N., R. 1 W. (Greenbush Twp.) To the north of Stronghurst the

dome is incompletely defined. There is a dip of over 50 feet per mile to the northeast toward Media.

There is an area of 100 to 150 square miles lying on the gentle east and southeast slope of the dome in which there have been no wells drilled deep enough to test out the horizon of the Hoing sand. If the sand is present in any portion of this area the geological conditions are favorable for the accumulation of oil, but the presence or absence of the sand can be demonstrated only by drilling. The first tests should be drilled well up on the structure, within the area bounded by the 550-foot contour line; that is, in secs. 31 and 32, T. 9 N., R. 4 W. (Stronghurst Twp.), in secs. 25, 26, 35, 36, T. 9 N., R. 5 W. (Stronghurst Twp.), and in secs. 5, 6, 7, 8, 9, T. 8 N., R. 4 W. (Raritan Twp.) Further drilling should be extended to the area included within the 500-foot contour line, in which case it would seem advisable to locate the first test in sec. 33, T. 8 N., R. 3 W. Good Hope quadrangle.

The principal structural features brought out by the contours on No. 2 coal include two small domes. West of Roseville in T. 9 N., R. 3 W. (Ellison Twp.), is an incompletely defined dome on which the coal rises to an elevation of 736 feet, which is about 30 feet higher than to the south and east. The Parrish well in the northwest quarter of section 34 was drilled down on the flank of the dome where the coal is about 25 feet lower than at the apex. It failed to find any Hoing sand, and it might be said to discredit the area in the immediate vicinity so far as the presence of the sand is concerned. It does not discredit the structure, however, since the distribution of the sand is so erratic.

A small dome lies just east of Roseville in sections 28, 29, 32, and 33. In section 28 the coal rises 20 feet higher than to the west, 30 feet higher than to the south, and 50 feet higher than to the east and north.

A pronounced terrace extends to the south from the above mentioned dome. It covers portions of secs. 9, 10, 15, 16, 19, 20, 21, 30, and 36, T. 8 N., R. 2 W. (Swan Twp.), where the coal lies at an elevation of about 680 feet, but rises to 693 feet in section 10. To the north and west the coal rises slightly, to the east it dips to an elevation of 620 feet, while to the south it slopes off very gently.

Six miles northwest of Bushnell there is a small dome in which the coal rises more than 20 feet above the adjacent region. Since it is incompletely defined, no recommendations can be accurately made; however, a test in the southeast part of sec. 16, T. 7 N., R. 2 W. (Walnut Grove Twp.), can be suggested.

In the southwestern portion of the Goodhope quadrangle is a broad terrace upon which No. 2 coal lies at an elevation of about 680 feet.

LOCALITIES ALREADY TESTED

Five wells have been drilled within the borders of each of the two quadrangles in search of oil or gas. In the Goodhope quadrangle, the most favorably located well, so far as structure goes, was the Parrish well in sec. 34, T. 9 N., R. 3 W. (Ellison Twp.) This well failed to find the Hoing sand. Its relation to structure is discussed in the description of the dome west of Roseville.

A well drilled on the George Sailor farm in the NE. $\frac{1}{4}$ sec. 21, T. 8 N., R. 1 W. (Greenbush Twp.), is located in a syncline and found no sand.

A well drilled on the Matt Boden farm in the NW. $\frac{1}{4}$ sec. 15, T. 7 N., R. 2 W. (Walnut Grove Twp.), is located upon the southern end of a gently sloping terrace. It likewise found no sand.

Two wells were drilled on the Bruinga and Lester farms in secs. 7 and 18, T. 6 N., R. 2 W. (Macomb Twp.) The logs of these wells are somewhat indefinite, but it appears that the well in section 18 lies on a small dome. Four feet of sand was reported at the base of the second lime, with a small showing of oil. The well in section 7 found no sand.

In the La Harpe quadrangle none of the five wells drilled is regarded as being favorably located. No data are available concerning the well one and one-half miles southwest of Sciota, except that it was a dry hole. Of the four remaining wells, two, the Herzog in the NE. $\frac{1}{4}$ sec. 30, T. 7 N., R. 4 W. (Blandinsville Twp.), and the Wilkes in the SW. $\frac{1}{4}$ sec. 25, T. 7 N., R. 5 W. (La Harpe Twp.), found no sand nor any show of oil. Of the other two the Gills in the NW. $\frac{1}{4}$ sec. 8, T. 6 N., R. 5 W. (Fountain Green Twp.), is reported to have found 20 feet of sand with a showing of gas. This information has not been verified, and no log of the well is available. The Gochenour well in the NE. $\frac{1}{4}$ sec. 3, T. 6 N., R. 5 W. (Fountain Green Twp.), found a showing of sand at the base of the second lime but no oil or gas.

GAS IN THE GLACIAL DRIFT

Small quantities of gas are frequently encountered in pockets of sand in the glacial drift. In a water well in the SW. $\frac{1}{4}$ sec. 9, T. 8 N., R. 2 W. (Swan Twp.), gas rises in bubbles through the water in such quantities that when a pipe was inserted through the well platform,

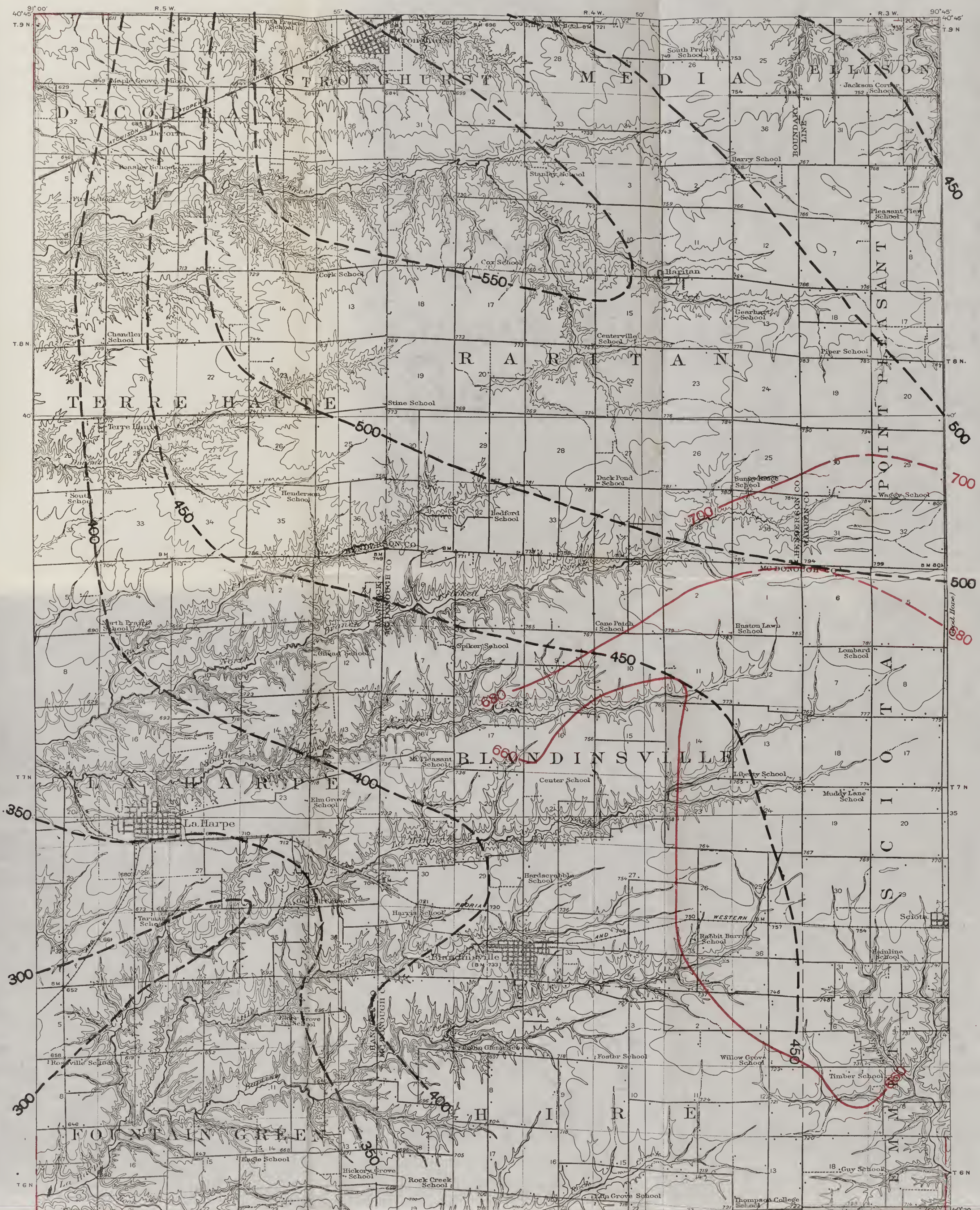

W. H. Herron, Acting Chief Geographer.
 Glenn S. Smith, Topographic Engineer in charge.
 Topography by C. W. Goodlove and J. A. Duck.
 Control by E. L. McNair, C. B. Kendall,
 R. G. Clinje, and S. R. Archer.
 Surveyed in 1916.

Duck
 Goodlove

Scale 62500
 Contour interval 20 feet.
 Datum is mean sea level.

Scale 1:62,500
 Miles
 Kilometers

STILL NORTH
 MAGNETIC NORTH
 APPROXIMATE MEAN
 DECLINATION, 1918

Engraved 1917 by U.S.G.S.
 Edition of 1918

MAP OF LA HARPE QUADRANGLE

Showing structural contours based upon the elevation of No. 2 coal (red) and upon the elevation of the Burlington limestone (black) above sea level

DESCRIPTION OF MAP

The heavy black lines show the position of the base of the Burlington limestone above sea level, and are to be considered apart from the fine black lines which represent the surface of the region. The reader is requested to imagine that the Burlington limestone and all the beds that overlie it are removed so that the upper surface of the underlying Kinderhook is exposed, and that the area is invaded by a sea three hundred feet above present sea level. The 300-foot black contour line would be the shore line at this stage, but if the level of the sea would rise 50 feet the shore line would creep to the position of the 350-foot contour, and similarly with each 50 foot rise the shore line would advance to the next higher contour line. Thus the surface of the top of the Kinderhook (or base of the Burlington) is high underlying section 33 of Point Pleasant Township and would remain above water until the water raised to almost 550 feet. The general dip of the beds is to the east.

In a similar manner the red contour lines show the position of No. 2 coal above sea level and the reader may follow a method in picturing its surface similar to the method just described for the Burlington limestone.

SPECIAL NOTICE

It is impossible to predict the presence of oil in any given area. The fact that the Hoing oil sand is present at only a comparatively few places adds an additional element of uncertainty in the western counties of Illinois. Since in most fields the oil accumulates where the sand has been folded upward, and since the downward folds or synclines are usually filled with salt water, a map which shows the position of the beds previous to drilling is very valuable. The operator can then confine his tests to territory where accumulations would take place if the other conditions were favorable. Thus one element of chance is eliminated.

ILLINOIS STATE GEOLOGICAL SURVEY

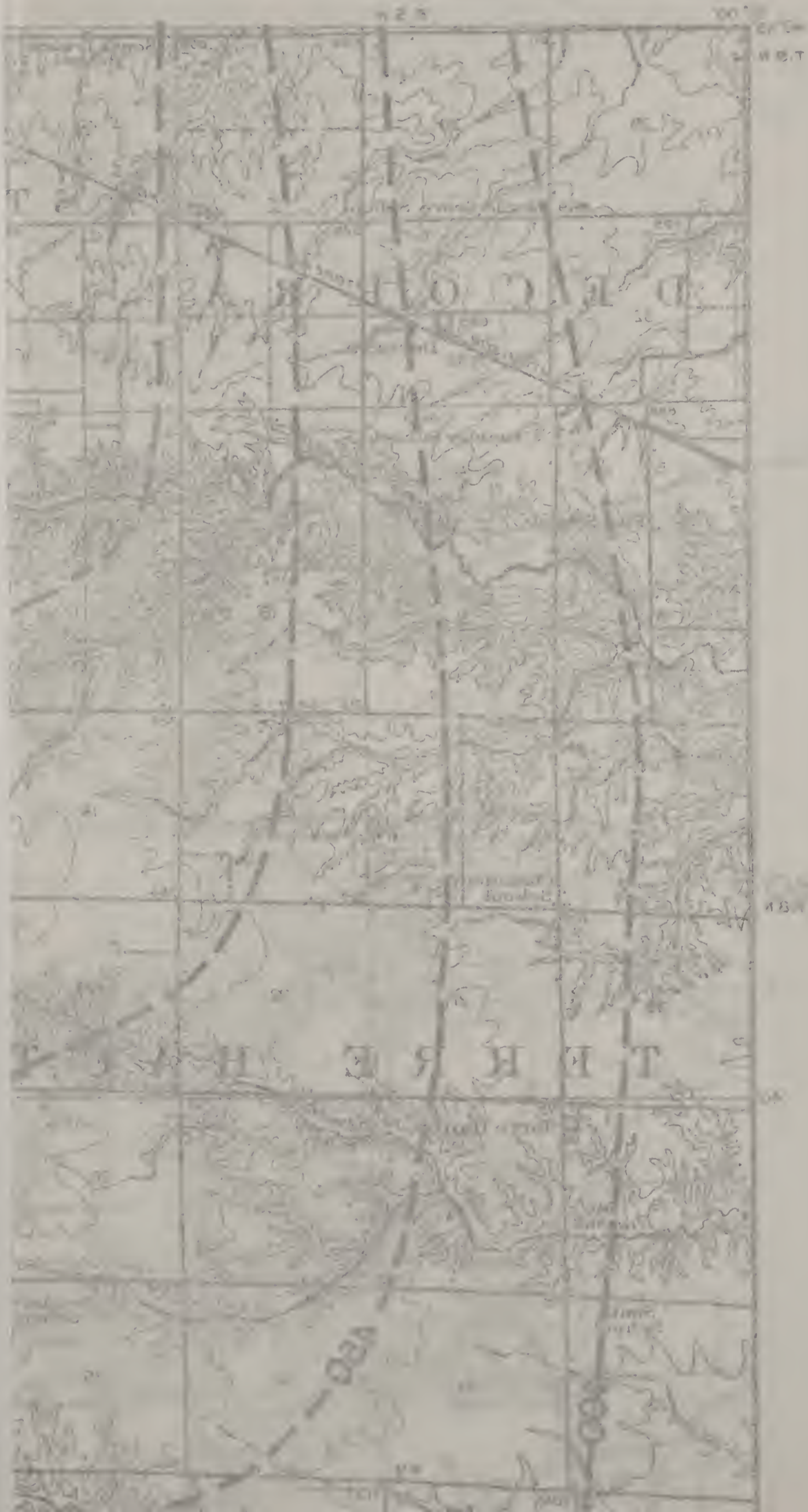

the gas could be ignited with a match and burned freely. Small quantities of gas have been reported in a number of other shallow water wells. In all cases of this sort the gas was probably derived from the decomposition of vegetable matter buried in the glacial drift and no considerable quantities are to be expected. This gas has no connection with the accumulation of oil or gas in the underlying rock strata and should not be confused with true oil seeps or gas escapages from solid rocks. It gives no indication whatever of the presence of oil or gas in the deeper strata.

PARTS OF PIKE AND ADAMS COUNTIES

By Horace Noble Coryell

OUTLINE

	PAGE
Introduction.....	70
Acknowledgments.....	71
Personnel of the party.....	71
Topography of the area.....	71
Method of field work.....	72
Key horizons.....	72
Relation of folds to accumulation of oil.....	73
The Hoing sand.....	73
Structure of the area.....	74
Synclines.....	74
Anticlines and terraces.....	74
Pittsfield-Hadley anticline.....	75
Method of study.....	75
Description of the structure.....	81
Development.....	82
The gas rock.....	83
Notes on wells in the columnar section sheet.....	83
Structures favorable for testing.....	84
Flowing water wells.....	86
Stratigraphy.....	86
General statement.....	86
Unconsolidated rocks.....	86
Alluvium.....	86
Loess.....	86
Drift.....	87
Consolidated rocks.....	87
Generalized section.....	87
Pennsylvanian system.....	89
Carbondale formation.....	89
Pottsville formation.....	91
Mississippian-Pennsylvanian unconformity.....	92
Mississippian system.....	92
St. Louis limestone.....	92
Salem limestone.....	93
Warsaw-Salem unconformity.....	93
Warsaw formation.....	93
Keokuk limestone.....	94
Burlington limestone.....	94

	PAGE
Kinderhook group.....	95
Devonian system.....	95
Upper Devonian shale.....	95
Silurian system.....	95
Niagaran limestone.....	95
Ordovician system.....	95
Maquoketa shale.....	95
Kimmswick-Plattin limestone.....	95

ILLUSTRATIONS

PLATES

IV. Map showing the structure of central and northern Pike County.....	72
V. Map showing the structure of southeastern Adams County.....	74
VI. Map of the crest of the Pittsfield-Hadley anticline and columnar sections of the wells in the area.....	80
VII. Map of the areal geology of central and northern Pike County.....	84
VIII. Map of the areal geology of southeastern Adams County.....	88
IX. (A-A) } Structure sections in southeastern Adams County.....	} .. 94
(B-B) }	
(C-C) }	
(D-D) } Structure sections in Central and Northern Pike County..	

FIGURES

16. Diagrammatic illustration of conditions favorable to artesian wells....	85
17. Diagrammatic cross-section showing the upper coal bed (key horizon No. 7) and Colchester (No. 2) coal (key horizon No. 3).....	90

TABLE

7. Summary of well data in central Pike County.....	76
---	----

INTRODUCTION

During the summer of 1918 a study of the structure of the northern and central parts of Pike County and the southeastern part of Adams County was made by the State Geological Survey in search of new areas favorable to the accumulation of oil. Figure 1 shows the area covered by this report.

The Colmar oil field on the north and the Pike County gas field on the south suggest that the intermediate area, which has similar geological conditions, may prove productive. The area is partly covered by this report, together with the companion paper on Brown County, and the previous one for Schuyler County.¹

Favorable structures for testing are described in the following pages, as indicated in the outline, and the uncertainties resulting from the irregular distribution of oil-bearing sands and other conditions are discussed. A brief description of the general geology of the region is also presented in the text and illustrations.

¹ Morse, W. C., and Kay, Fred H., Area south of the Colmar oil field: Ill. State Geol. Survey Bull. 31, 1915.

ACKNOWLEDGMENTS

M. L. Nebel was in general supervision of the work for the early period, and introduced the writer to the geology of the region. Stuart Weller assisted in the identifications and correlations of the rocks. The reports of oil investigations in western Illinois by other members of the Survey were consulted in the study of the Hoing sand. Messrs. Jerry Mink, Earl Harris, and Claude Shinn kindly furnished the records of numerous wells drilled in central Pike County.

PERSONNEL OF THE PARTY

The party in immediate charge of the writer included M. C. Winkur, as levelman throughout the season, and Marvin Weller for a short period near the close. Others employed as rodmen for variable periods were: Charles Aiken, George F. Baldwin, Milton Chestnut, Virgil Harte, George Holmes, Frank T. Orndorff, Harry Ramsey, Otis Shake, George Stauffer, Virgil Tooley, H. E. Van Natta, and Fred Wright.

TOPOGRAPHY OF THE AREA

Plate IV is a map of the coal and gas fields in the northern and central parts of Pike County. This area lies upon the divide between the Mississippi and Illinois rivers. The western part is drained by Six Mile, Kiser, and Hadley creeks into the Mississippi, and the eastern part by Bay, Blue, and McGees creeks into the Illinois. The upland is hilly, except near Maysville and New Salem. The flood plains are narrow, and are dissected in many places by the winding stream channels. The soil and weathered rock on the slopes of the valleys, eroded into the shales of the Pennsylvanian ("Coal Measures"), creeps and slumps rapidly and covers the consolidated rocks in the beds of the streams. Fortunately, the coal (Colchester) is exposed in numerous pits and banks that have been worked recently.

Plate V is a map of southeastern Adams County. Only the area south of the "Base Line" was covered by the geological survey, but in order to show the location of the district in reference to the railroads, the map was extended two miles farther north to include Clayton, Camp Point, and Coatsburg.

The belt of level upland which crosses the area near Beverly and Liberty forms the divide between the Mississippi and Illinois rivers. The southwest slope is drained by McCraney Creek into the Mississippi, and the northeast slope by McGees Creek and its tributaries into the Illinois. The upland north and northwest of Kellerville is a flat prairie

lying on the divide between McGees Creek and Bear Creek drainage systems. There are very few exposures of the consolidated rocks in the level areas, and only a small number of farm wells pass through beds that can be identified from the available information. The study of the structure of the key beds is approximately limited to the stream valleys where the contacts between the formations are exposed, and where numerous wells and pits pass through the coal bed.

METHOD OF FIELD WORK

The outcrops of the consolidated rocks were studied, and those that could be identified were located by pacing and compass, and described with considerable detail in reference to characteristic features represented on the postal road map which was used for a base. The map served later to guide the leveling party.

The top of the Colchester (No. 2) coal was chosen as the principal key horizon for the entire area, except in the Pike County gas field, where the top of the gas rock was used as the datum plane (Plate IV). Contours and cross-sections show the "lay" or structure of the key rocks. The structure, represented by contours on the coal, differs somewhat from the structure of the deeper beds at the horizon of the Hoing sand in the Colmar field, since the St. Louis, Salem, Warsaw, and Keokuk, which are present in the northern part of the area, are absent in the southern part (Plates VII and VIII). The lack of parallelism between the coal and the deeper beds is discussed on the later pages, but is not great enough to interfere seriously with conclusions drawn from study of the "coal contours". The intervals between the coal, as the principal key bed, and the other formations upon which points were located were measured wherever possible. The elevations of these points were reduced or increased to the elevation of the top of the coal at each point by subtracting or adding the stratigraphic distance, as determined in the nearest measured section. The observed and the computed elevations of the top of the coal were plotted on the maps (Plates IV and V). Contours were drawn through points of equal elevations and show graphically the downfolds (synclines) and upfolds (anticlines) of the principal key bed, which appears as No. 3 in the following list of key horizons.

KEY HORIZONS

The following list gives the key horizons and the stratigraphic distance to the top of the Colchester (or No. 2) coal.

7. Top of the upper coal bed, 75 to 80 feet above the Colchester coal.
6. Bottom of second nodular limestone 63 to 72 feet above the Colchester coal.

LEGEND

Outside of Stippled Boundary

- X Outcrop of key horizon No.3
- 645 Elevation of No.2 coal
- Dry hole
- 603 Computed elevation of No. 2 coal
- Dry hole
- 224 (○) Elevation of gas sand
- Water well
- 660 Computed elevation of No. 2 coal
- 650 Contours show elevation of No.2 coal above sea level

Within Stippled Boundary

- Gas producing well
- 476 Computed elevation of top of gas sand
- Dry hole gas test
- 472 Computed elevation of top of gas sand
- Water well
- 414 Computed elevation of top of gas sand
- Dry hole oil test
- 410 Computed elevation of top of gas sand
- X Outcrop of No. 2 coal
- 467 Computed elevation of top of gas sand

600 Contours show elevation of top of gas sand above sea level

LEGEND

- County line
- - - U. S. Township line
- Town
- ▣ County seat

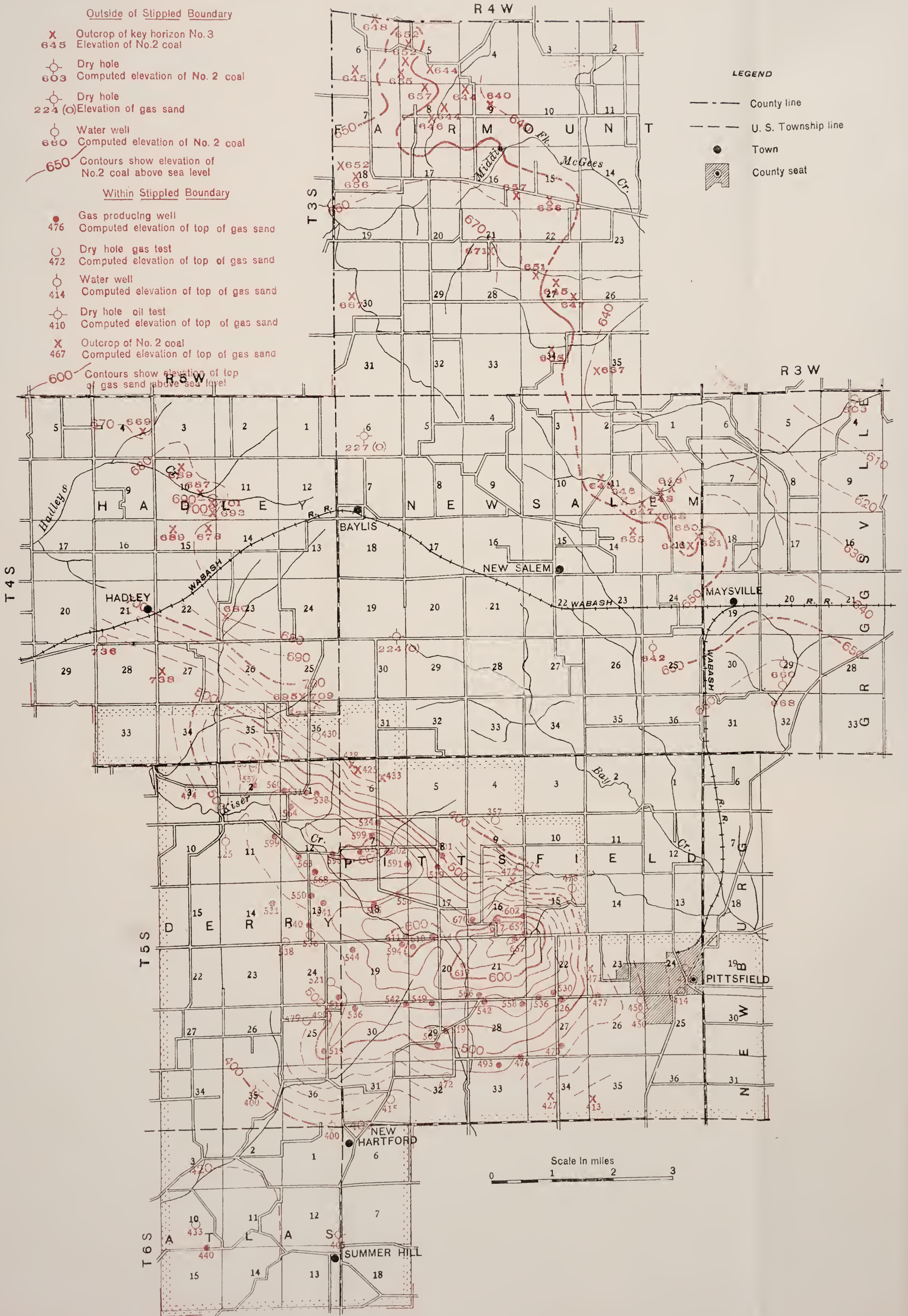

Map showing the structure of central and northern Pike County

Legend

	Well	1957
	Well	1957
	Well	1957
	Well	1957
	Well	1957
	Well	1957
	Well	1957
	Well	1957
	Well	1957
	Well	1957
	Well	1957
	Well	1957
	Well	1957
	Well	1957
	Well	1957
	Well	1957
	Well	1957
	Well	1957
	Well	1957
	Well	1957
	Well	1957
	Well	1957
	Well	1957
	Well	1957
	Well	1957
	Well	1957
	Well	1957
	Well	1957
	Well	1957
	Well	1957
	Well	1957
	Well	1957
	Well	1957
	Well	1957
	Well	1957
	Well	1957
	Well	1957
	Well	1957
	Well	1957
	Well	1957
	Well	1957
	Well	1957
	Well	1957
	Well	1957
	Well	1957
	Well	1957
	Well	1957
	Well	1957
	Well	1957
	Well	1957
	Well	1957
	Well	1957
	Well	1957
	Well	1957
	Well	1957
	Well	1957
	Well	1957
	Well	1957
	Well	1957
	Well	1957
	Well	1957
	Well	1957
	Well	1957
	Well	1957
	Well	1957
	Well	1957
	Well	1957
	Well	1957
	Well	1957
	Well	1957
	Well	1957
	Well	1957
	Well	1957
	Well	1957
	Well	1957
	Well	1957
	Well	1957
	Well	1957
	Well	1957
	Well	1957
	Well	1957
	Well	1957
	Well	1957
	Well	1957
	Well	1957
	Well	1957
	Well	1957
	Well	1957
	Well	1957
	Well	1957
	Well	1957
	Well	1957
	Well	1957
	Well	1957
	Well	1957
	Well	1957
	Well	1957
	Well	1957
	Well	1957
	Well	1957



142

138

5. Top of the *Productus* and *Chonetes* bed, 10 to 15 feet above the Colchester coal.
4. Top of septarian concretion layer, 6 to 8 feet above the Colchester coal.
3. Top of the Colchester coal (principal key horizon).
2. Top of the Salem limestone, 24 to 57 feet below the Colchester coal.
1. Top of the gas rock 293 to 298 feet below the Colchester coal and used as the key bed in the area within the stippled boundary (Plate IV).

RELATION OF FOLDS TO ACCUMULATION OF OIL

In most of the productive fields of Illinois oil occurs in the upper part of anticlines domes, and terraces. The localization of the oil accumulations within these upfolds depends upon the extent of the sand body and the amount of salt water present. Where the oil sand extends over the anticline, and an abundance of salt water exists, the oil and gas occur in the positions shown in figure 14 A. With a less amount of salt water to buoy up the oil, the accumulation takes place farther down the slope of the anticline, localizing in the terraces (figure 14 B). If salt water is absent and the sand is not saturated with oil, the oil pools occur in the synclines (figure 14 C).

In western Illinois the sand contains considerable quantities of salt water; the domes and terraces are discovered by geologic work, but the distribution of the sand can not be determined in advance of the drill.

THE HOING SAND

Oil was discovered in 1914 near Colmar on the farm of J. Hoing. The producing sand was described as the Hoing sand. Numerous wells were drilled in this locality, in some of which the sand is present and in others absent. The well records show that the Hoing sand is distributed in isolated lenses varying from a few feet up to 30 feet in thickness, and that it lies between the Maquoketa shale and the "second lime" of the drillers. The name has been mistakenly extended to include the producing and non-producing sands in Schuyler County that lie immediately below the "second lime." The variability in thickness and distribution is probably due to the limitation of deposition of the sand to shallow disconnected depressions in the surface of the Maquoketa shale and to subsequent erosion.

The shale beneath and the Niagaran limestone above prevent the migration of the oil and gas from one sand body to another. Each deposit of sand is a unit within itself, in reference to the accumulation and

differentiation of the gas, oil, and salt water. A well on the crest of an anticline would test a lens of the sand if one were present, but it would not adequately test the entire fold. Wells drilled into lenses on terraces that lie below the crest of the anticline are known to be productive in the Colmar field, while the deposits of sand higher on the fold yield only salt water.¹

STRUCTURE OF THE AREA

The beds have a general dip eastward which is interrupted by numerous undulations—synclines, anticlines, and terraces.

SYNCLINES

In sec. 28, T. 3 S., R. 6 W. (Richfield Twp., Plate V), is a small basin in which the Colchester coal is 20 feet lower than in the adjacent area and has a thickness of 8 feet. Either this depression was probably a peat swamp for a longer time during the Carbonale epoch than the surrounding region, or the accumulation of the plant material was more rapid. The difference in elevation may be due in part to the difference in degree of compressibility of the thick plant deposit and the surrounding sediment.

In the small syncline in the west half of sec. 8, T. 3 S., R. 6 W. (Richfield Twp., Plate V), the thickness of the coal was 3 feet. The Colchester coal was 11 feet thick in a small depression near the center of sec. 10, T. 4 S., R. 5 W. (Hadley Twp., Plate IV). Several years ago it was mined and used by the Wabash Railroad.

Near the center of T. 3 S., R. 6 W. (Richfield Twp., Plate V), is a large syncline (Plate IX B-B) which would probably be found to extend to the northeast corner of the township and then northwest to Liberty if the structure were completely defined. The flowing well on the farm of Luther Rice is located in the western part of the syncline, NW. $\frac{1}{4}$ sec. 17, T. 3 S., R. 6 W., (Richfield Twp., Plate V). In the eastern half of T. 2 S., R. 5 W., (McKee Twp., Plate V), is a broad shallow syncline which has an area of approximately nine square miles.

ANTICLINES AND TERRACES

In secs. 3, 4, 5, 6, 9, 10, 11, 14, and 15, T. 3 S., R. 5 W. (Beverly Twp., Plate V), is an anticline which extends in a northeast-southwest direction. The north limb is slightly depressed in sections 11 and 4. A "nose" extends northward from section 5 and develops into a terrace

¹Morse, W. C., and Kay, Fred H., The Colmar oil field—a restudy: Ill. State Geol. Survey Bull. 31, p. 43, 1915.

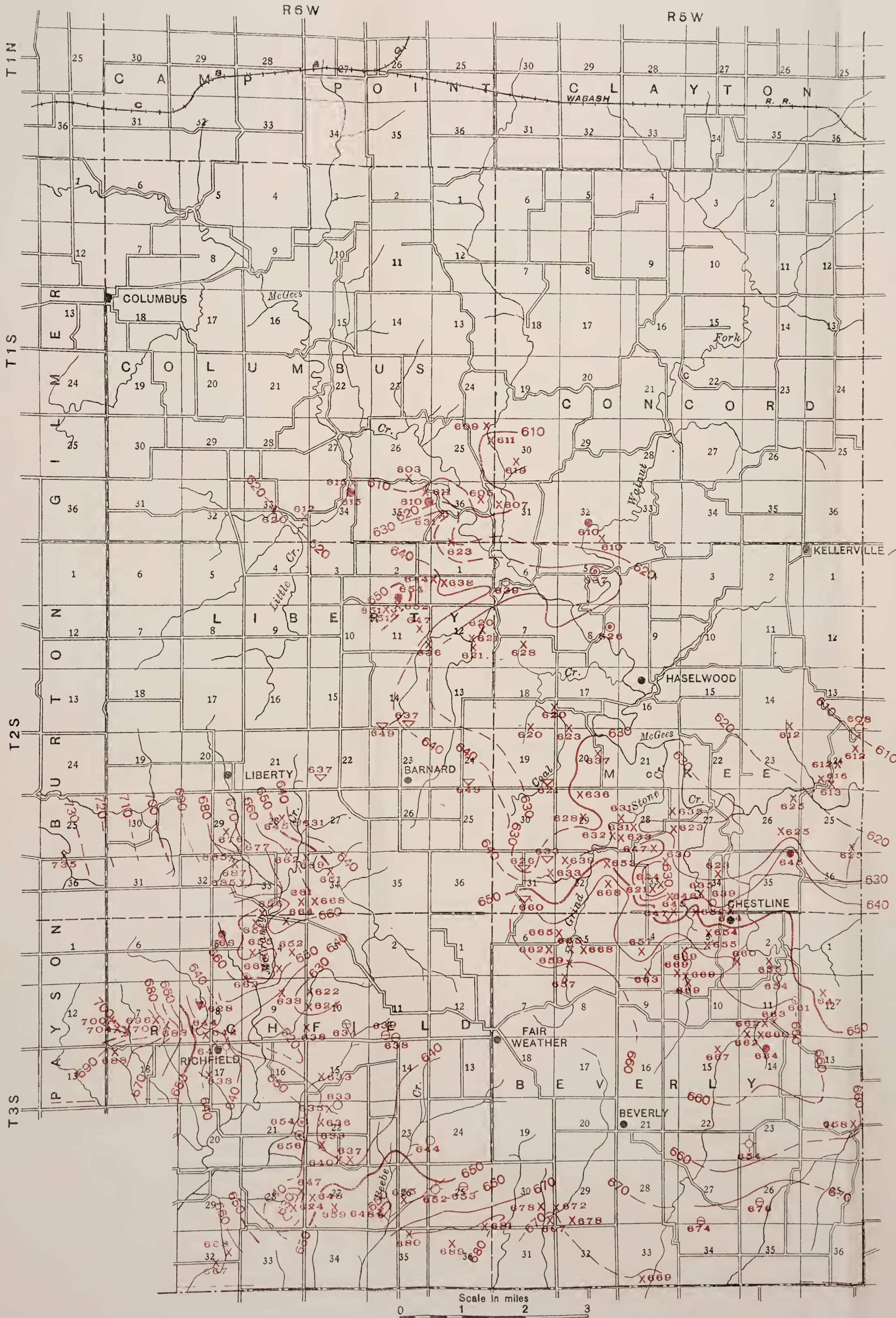

- LEGEND**
- County line
 - U. S. Township line
 - Town
 - ⊖ Outcrop of key horizon No. 7
655 Computed elevation of No. 2 coal
 - ▽ Outcrop of key horizon No. 5
620 Computed elevation of No. 2 coal
 - ▽ Outcrop of key horizon No. 6
637 Computed elevation of No. 2 coal
 - Outcrop of key horizon No. 4
639 Computed elevation of No. 2 coal
 - X Outcrop of key horizon No. 3
610 Elevation of No. 2 coal
 - ⊙ Outcrop of key horizon No. 2
626 Computed elevation of No. 2 coal
 - 630 Contours show elevation of No. 2 coal above sea level
 - ⊕ Dry hole
652 Computed elevation of No. 2 coal
 - ⊙ Water well
654 Computed elevation of No. 2 coal

Scale in miles
0 1 2 3

Map showing the structure of southeastern Adams County

PLANS OF THE TOWN OF BOSTON

W 88



MIT

211

515

152

two miles wide, which lies in secs. 20, 21, 27, 28, and 29, T. 2 S., R. 5 W. (McKee Twp.) The coal in the terrace is 30 feet lower than on the crest of the anticline. The west and south slopes of the anticline are not completely defined; but the information available shows that the coal dips at a low angle into the Richfield syncline on the west, and into the narrow basin near Beverly on the south.

A narrow terrace lies in secs. 5, 6, 7, and 8, T. 2 S., R. 5 W. (McKee Twp.), and secs. 1, 2, 11, and 12, T. 2 S., R. 6 W. (Liberty Twp., Plate V). It is approximately four miles long and three-quarters of a mile wide. The fold becomes much broader toward the west, and may develop into a more favorable structure for oil accumulation under the drainage divide in Liberty Township.

There are numerous small anticlines and terraces in T. 3 S., R. 6 W. (Richfield Township, Plate V), in which the Colchester coal rises only 10 feet or less above the coal bed in the nearby region. They are interesting for study but unimportant in relation to oil accumulations.

North of Fish Hook, in secs. 5, 6, 7, and 8, T. 3 S., R. 4 W. (Fairmount Twp., Plate IV), occurs a narrow terrace in a splendid location to serve as a collecting area for the long slope that extends for several miles into Brown County. It lies upon the eastern slope of the anticline in T. 3 S., R. 5 W. (Beverly Twp., Plate V).

Two miles north of Hadley (Plate IV) is located an incompletely defined terrace which probably connects with the terrace in sec. 36, T. 3 S., R. 6 W. (Richfield Twp., Plate V).

PITTSFIELD-HADLEY ANTICLINE¹

METHOD OF STUDY

From the owner of each gas well were secured the data given in the "Summary of well data of central Pike County", (Table 7), and from the drillers were obtained the well logs. The top of the gas rock was chosen as the datum horizon upon which to base the graphic representation of the structure of the region. The surface elevation of each well, as determined by the leveling party, was reduced to the elevation of the top of the gas rock by subtracting the interval from the surface to the gas-producing bed, as given in the log. Since there is an interval between the gas rock and the key bed (Colchester coal) used outside of the gas area of from 293 to 298 feet, the contours near the border of the gas area, which pass through elevations computed from the elevation of the coal, will not coincide vertically at the stippled boundary with the contours of the coal. This is noticeable in secs. 35 and 36, T. 4 S., R. 5 W. (Hadley Twp.).

¹Area enclosed by stippled boundary, Plate IV.

OIL INVESTIGATIONS

TABLE 7.—Well data in central Pike County

Location		Part of section	Owner	Ref. No.	Driller	Date of drilling	Source of log	Elevat'n		Total depth	Condition		Remarks
Township	Sec							Surface	Top of Gas rock		Initial	1918	
Griggsville (T. 4 S., R. 3 W.)	3	NE cor. SE $\frac{1}{4}$	Sleight, J.	1	Simonds	250	Water	Water	Gas is not used	
	4	NW cor. NE $\frac{1}{4}$	Bradshaw, S.	2	T. Hill	496	335	Salt water and gas	Flowing salt water	Gas was never used	
New Salem (T. 4 S., R. 4 W.)	29	SE $\frac{1}{4}$	Hopkins, Capt. B. B.	3	R. Perry	1900	684	90	Gas	Filled	Show of gas. Trace of lead and zinc	
		cen. S $\frac{1}{4}$ SW $\frac{1}{4}$	Watkins, J. F.	4	Hazelrig	676	124	Water	Water	Abandoned	
	6	cen. S $\frac{1}{4}$	Seaborn, W. H.	5	Ohio Oil Co.	1917	829	619	Show of oil	Plugged	Colchester coal 642 feet above sea level	
	19	SE cor.	White, A. W.	6	Ohio Oil Co.	1917	840	616	Dry	Water well		
Hadley (T. 4 S., R. 5 W.)	25	NW $\frac{1}{4}$ NW $\frac{1}{4}$	Dunham, Wm.	7	H. Dunham	724	90	Water	Water		
	21	SW cor.	Triplet	8	766	130	Water	Water		
Pittsfield (T. 5 S., R. 4 W.)	35	SW cor. SE $\frac{1}{4}$	Moyer, O. A.	9	Jerry Mink	692	588	110	Gas	Water	Colchester coal 736 feet above sea level	
	36	N $\frac{1}{4}$ SE $\frac{1}{4}$	Irick, Jacob	10	Jerry Mink	1905	774	430	372	Dry	Filled	Water shut off gas	
	3	NE cor.	Lewis, A.	11	Jerry Mink	1911	749	542	208	Gas	Gas	Upper 24 ft. used for water well	
	6	Center N $\frac{1}{4}$	Harshman, N.	12	A. J. Clark	1905	757	690	Dry	Filled		
Pittsfield (T. 5 S., R. 4 W.)	6	NW $\frac{1}{4}$ SW $\frac{1}{4}$	Irick, A.	13	1905	675	770	Dry	Filled		
		NW cor.	Mink, Jerry	14	Jerry Mink	1905	762	460	Show of gas	Filled		
	7	NW cor. NE $\frac{1}{4}$	Austin, Thos.	15	A. J. Clark	1906	773	524	249	Gas	Gas & water	Pressure very weak	
		NE $\frac{1}{4}$ NW $\frac{1}{4}$	McSorley, J.	16	A. J. Clark	1906	751	599	188	Gas	Gas		
Pittsfield (T. 5 S., R. 4 W.)		cen. N line SW $\frac{1}{4}$	McSorley, M.	17	A. J. Clark	1905	686	610	76	Gas	Gas	One of the strongest wells	
		4 mi. E. of cen	Nash, Michael	18	A. J. Clark	1906	723	602	157	Gas	Gas		

PARTS OF PIKE AND ADAMS COUNTIES

8	Cen. E. line SW $\frac{1}{4}$	O'Connell, M.	1907	Jerry Mink	754	591	181	Gas	Gas	Gas	
	S $\frac{1}{2}$	Davis, Capt.	1906	A. J. Clark	799	519	280	Gas	Gas	Gas	
	Near cen.	Haney, Joseph	1906	A. J. Clark	814	501	313	Dry	Dry	Filled	
9	SE cor.	Fudge, C. A.	1907	Jerry Mink	766	424	356	Gas show	Water	Water	
	NE $\frac{1}{4}$ NW $\frac{1}{4}$	West, Benj.	1906	A. J. Clark	839	357	503	Dry	Water	Water	Gas for cooking and lights
10	Center	Winans, I. N.	1905	Jerry Mink	760	555	242	Gas	Gas	Gas	
	NW $\frac{1}{4}$ NE $\frac{1}{4}$	Langan, S.	1910	Jerry Mink	773	478	302	Dry	Filled	Filled	
16	NW $\frac{1}{4}$ SW $\frac{1}{4}$	Boyd, Louis		Jerry Mink	855	570	286	Gas	Gas	Gas	
	SE cor.	Helms, J. H.	1906	Jerry Mink	822	657	167	Gas	Gas	Gas	
	NE $\frac{1}{4}$ SW $\frac{1}{4}$	Pennock, J.		Jerry Mink	841	617	235	Gas	Gas	Gas	
	NE $\frac{1}{4}$ SE $\frac{1}{4}$		1909	Jerry Mink	816	602	214	Gas	Gas	Gas	
17	SE $\frac{1}{4}$ SW $\frac{1}{4}$	Coldwater School	1907	Jerry Mink	842.8	614	240	Gas	Gas	Gas	
	SW $\frac{1}{4}$ NE $\frac{1}{4}$	Dutton, Louis	1910	Jerry Mink	838	543	319	Gas	Gas	Gas	
	SW $\frac{1}{4}$ SW $\frac{1}{4}$	Dutton, Wm.	1905	Jerry Mink	844	596	263	Gas	Gas	Gas	
	SE $\frac{1}{4}$ SW $\frac{1}{4}$	Higgins & Strauss	1906	Jerry Mink	844	615	251	Gas	Gas	Gas	
18	NW $\frac{1}{4}$ NE $\frac{1}{4}$	Hall, Nannie	1907	Jerry Mink	783	558	237	Gas	Gas	Gas	Pressure de-creasing
	SE cor.	Wackerman, F. P.	1906	Jerry Mink	861	611	276	Gas	Gas	Gas	
	NW $\frac{1}{4}$ NW $\frac{1}{4}$	Criss, Wm.	1908	A. J. Clark	823	544	279	Gas	Gas	Gas	Pressure de-creasing
	NW cor.	Lloyd, W. S.	1906	Jerry Mink	853	594	273	Gas	Gas	Gas	
20	NE $\frac{1}{4}$ NW $\frac{1}{4}$	Foster, R. J.	1907	Jerry Mink	847	571	279	Gas	Gas	Gas	Pressure de-creasing
	NW cor.	Smith, M. J.	1906	Jerry Mink	828	610	231	Gas	Gas	Gas	
	SE $\frac{1}{4}$ NE $\frac{1}{4}$	Wills, W. R.	1906	Jerry Mink	823	619	219	Gas	Gas	Gas	Pressure very weak
21	NW $\frac{1}{4}$ NE $\frac{1}{4}$	Ducey, John	1906	Jerry Mink	840	667	184	Gas	Gas	Gas	Deep oil test
	SW $\frac{1}{4}$	Wills, A. V.	1906	Jerry Mink	831	566	294	Gas	Gas	Gas	
	NE cor. NW $\frac{1}{4}$	Wills, A. V.		Hendricks	819						
22	$\frac{1}{4}$ mi. E. of SW cor.	Wilsey, C. L.	1906	Jerry Mink	859	527	333	Gas	Gas	Gas	
	$\frac{1}{4}$ mi. E. of SW cor.	Wilsey, C. L.	1906	Jerry Mink	843	530	313	Gas	Gas	Gas	Pressure very weak
	SW cor.	Wilsey, E. J.	1908	Jerry Mink	866	536	330	Gas	Gas	Gas	
23	SW cor.	James, T. F.	1912	Jerry Mink	818	477	302	Gas	Gas	Gas	Becoming very weak. Coal in well
	SW cor.	James, T. F.	1912	Jerry Mink	815	477	299	Gas	Gas	Gas	Becoming very weak. Coal in well
24	NW $\frac{1}{4}$ SE $\frac{1}{4}$	Doss, C. H. & Co.		A. J. Clark	724	410	352	Dry	Filled	Filled	
	SE cor. SW $\frac{1}{4}$	High School		Jerry Mink	715	414	321	Dry	Water	Water	
	Cen. SE $\frac{1}{4}$	Pittsfield well			722			Water	Water	Water	
25	SE cor. NW $\frac{1}{4}$	Kaaser, D.		A. J. Clark	730		333	Little oil	Water	Water	
26	NE $\frac{1}{4}$ NE $\frac{1}{4}$	Dutton, J. L.			775		55	Water	Water	Water	Colchester coal 730 feet above sea level
	NE $\frac{1}{4}$	Dutton, J. L.		Jerry Mink	726	450	276	Dry	Filled	Filled	

OIL INVESTIGATIONS

TABLE 7.—Well data in central Pike County—Continued.

Location		Owner	Ref. No.	Driller	Date of drilling	Source of log	Elevat'n		Total depth	Condition		Remarks
Township	Part of section						Surface	Top of Gas rock		Initial	1918	
Derry (T. 5 S., R. 5 W.)	27	Hughes, James. Kinneman, Mrs. G	55 56	A. J. Clark Jerry Mink...	1912	Jerry Mink.....	807 855	539	329	Dry..... Gas.....	Filled..... Gas.....	Sufficient gas for three houses pressure very weak
		Mills, Henry.....	57	Jerry Mink....	1912	850	526	325	Gas.....	Gas.....	Little gas but not used
		Wilsey, Riley....	58	Jerry Mink....	1906	Jerry Mink.....	822	473	352	Gas.....	Abandoned.	
	28	Quinlan, P.....	59	A. J. Clark....	1910	770	476	294	Gas.....	Gas & water	Both gas and water are used
		Stickman, W.....	60	Jerry Mink....	Jerry Mink.....	857	558	304	Gas.....	Gas.....	
		Strauss Bros.....	61	Jerry Mink....	Jerry Mink.....	819	542	298	Gas.....	Gas.....	
	29	Bridwell, J. S....	62	A. J. Clark....	1906	811	514	298	Gas.....	Gas.....	Pressure very weak
		Cooper, J. G.....	63	Jerry Mink....	1906	Jerry Mink.....	800	549	274	Gas.....	Gas.....	
		Ducey, J.....	64	1906	806	Gas.....	Gas.....	
		Kaaser, Emma..	65	Jerry Mink....	1906	Jerry Mink.....	820	505	328	Gas.....	Gas.....	Samples are available
	30	Strauss Bros.....	66	J. Gettman...	1917	Jerry Mink.....	684	Gas.....	Filled.....	Abundance of gas was found
		Strauss Bros.....	67	Jerry Mink....	1907	Jerry Mink.....	789	536	258	Gas.....	Gas.....	
	31	Ellis, G. H.....	68	Jerry Mink....	1906	Jerry Mink.....	791	415	353	Dry.....	Filled.....	
		Shinn, Claud....	69	J. Gettman...	1917	708	568	450	Show of oil	Plugged....	Casing pulled
	32	Buchanan, Wm..	70	Jerry Mink....	1908?	Jerry Mink.....	787	472	324	Little gas.	No gas.....	Used for water well
	33	Metzger, J.....	71	A. J. Clark....	1906?	752	Gas.....	Gas & water	Both gas and water are used
		Quinlan, H.....	72	A. J. Clark....	1908	788	193	295	Gas.....	Gas.....	Pressure weak
	34	Wilsey, J. G.....	73	A. J. Clark....	1911	805	230	Gas.....	Gas.....	Sufficient gas for cooking
35	County farm....	74	Hoskin.....	Selly Forinan...	760	206	Dry.....	Water.....	Colchester coal in well	
	Croxville, W.....	75	Jerry Mink....	Jerry Mink.....	689	560	145	Gas.....	Gas.....		
	Gerard.....	76	Jerry Mink....	717	532	185	Gas.....	Gas.....		
	Irick, Wm.....	77	1905	715	564	203	Gas.....	Gas.....		
	Lewis, F. G.....	78	1886	717	531	186	Gas.....	Gas.....	Dug for water by Jacob Irick	

NW 1/4 SE 1/4	Lewis, F. G.	79	1886		70	538	168	Gas.	Filled	Dug for water by Jacob Irick
2 Cen. NE 1/4	Lewis, F. G.	80	1905	Jerry Mink.	738	212	212	Gas.	Cased.	Not used
3 SW 1/4 NE 1/4	Carney, J.	81	1905	Jerry Mink.	652	557	112	Gas.	Gas.	Not used
9 Cen. S. side SW 1/4	Moyer, O. A.	82	1905	Jerry Mink.	612	474	138	Water.	Water.	
11 NW cor. NW 1/4 NE 1/4	Ownby, W. B.	83	1890?	Hendricks.	667	300+	300+	Gas odor.	Water.	
12 Center W 1/4 SE cor. NE 1/4	Moyer, W. H.	84	1890?	Jerry Mink.	629	525	174	Show of oil	Water.	
	Saylor, A.	85	1905	Jerry Mink.	685	559	84	Gas.	Gas.	
	Harshman, C.	86	1905	Jerry Mink.	677	563	152	Gas.	Gas.	
	Irick, Jessie.	87	1905	Jerry Mink.	693	568	115	Gas.	Gas.	Show of oil
	Reed, John.	88	1906	A. J. Clark.	784	598	150	Gas.	Gas.	Pressure de-creasing
13 Cen W 1/4 NE 1/4	Barley, L.	89	1909	Jerry Mink.	811	541	268	Gas.	Gas.	
NE cor. SW 1/4	Carrol, T. J.	90	1909	Jerry Mink.	782	540	284	Gas.	Gas.	
NE 1/4 NW 1/4	Hoskin, M. L.	91	1915	Jerry Mink.	817	536	297	Dry.	Filled.	
NE cor. SW 1/4	Irick, Geo.	92	1915	Earl Harris.	827	538	297	Dry.	Filled.	
SE cor. SW 1/4	Irick, Geo.	93	1913?	Earl Harris.	770	531	202 1/2	Gas.	Gas.	Not used
14 Cen. E. line NE 1/4	Haney, T. L.	94	1910	Jerry Mink.	827	300?	300?	Dry.	Water.	
SE cor.	School well.	95	1906	Henry Jones.	769	444	444	Little gas.	Water.	Little gas
17 NE cor.	Jones, Henry.	96	1906	Hazelrig.	521	253	253	Water.	Water.	Produced gas eleven years
20 NE cor.	Carney, J.	97	1906	Jerry Mink.	710	513	197	Gas.	Gas.	Pressure very weak
21 NW cor.	Hazelrig, W.	98	1906	Hendricks & Slavens.	705	514	192	Gas.	Gas.	Pressure very weak
22 NE 1/4 SE 1/4	Mays, M. J.	99	1909	Jerry Mink.	752	519	241	Gas.	Gas.	Pressure too weak to be used
SE cor.	Ruse, F. M.	100	1907?	Hendricks & Slavens.	680	479	201	Gas.	Gas.	
SE cor.	Ruse, F. M.	101	1909	Hendricks & Slavens.	696	499	197	Gas odor.	Filled.	
SE cor.	Ruse, F. M.	102	1911	Hendricks & Slavens.	696	503	197	Gas odor.	Filled.	Very little water
25 NW 1/4 SE 1/4	Ator, Elmer.	103	1914	Jerry Mink.	632	400	632	Dry.	Water.	Abandoned
NW 1/4 NE 1/4	Little, James.	104	1917	Hendricks & Slavens.	634	750	750	Show of oil	Plugged.	Casing pulled
SE 1/4 NE 1/4	Morrissey, M. J. and J. W.	105	1913	Hendricks & Slavens.	742	410	347	Heavy oil.	150 feet of heavy oil.	Surface of oil rises a few feet each year
SE 1/4 NE 1/4	Morrissey, M. J. and J. W.	106	1913	Hendricks & Slavens.	742	410	347	Heavy oil.	150 feet of heavy oil.	Surface of oil rises a few feet each year
35 NW 1/4 NE 1/4	Strubinger, R.	107	1913	Hendricks & Slavens.	742	410	347	Heavy oil.	150 feet of heavy oil.	Surface of oil rises a few feet each year
36 SW 1/4 SW 1/4	Shinn, Claud.	108	1913	Hendricks & Slavens.	742	410	347	Heavy oil.	150 feet of heavy oil.	Surface of oil rises a few feet each year
SE cor.	Shinn, Claud.	108	1913	Hendricks & Slavens.	742	410	347	Heavy oil.	150 feet of heavy oil.	Surface of oil rises a few feet each year

TABLE 7.—Well data in central Pike County—Concluded

Location		Part of section	Owner	Ref. No.	Driller	Date of drilling	Source of log	Elevation		Total depth	Condition		Remarks
Township	Sec.							Surface	Top of gas rock		Initial	1918	
Martinsburg (T. 6 S., R. 4 W.)	19	SE $\frac{1}{4}$ NW $\frac{1}{4}$	McGleason, E.....	109	Hendricks & Harris.....	Earl Harris.....	733	300	Dry.....	Water.....	
Atlas (T. 6 S., R. 5 W.)	1	NE cor.....	Shinn, Claud.....	110	Bridgeport Oil Co.....	1914	719	605	Show of oil	Water.....	Used for water well
	10	SW $\frac{1}{4}$ SE $\frac{1}{4}$	Anderson, Les..	111	Jerry Mink...	1906	Jerry Mink.....	752	440	325	Gas.....	Gas.....	Pressure weak
		NW $\frac{1}{4}$ SE $\frac{1}{4}$	Harter, W. M....	112	A. J. Clark....	1905	741	433	309	Little gas.	Filled.....	
	12	SE $\frac{1}{4}$ SE $\frac{1}{4}$	Summer Hill Lt. & Fuel Co.....	113	A. J. Clark....	1908	W. H. Gay.....	742	403	911 $\frac{1}{2}$	Dry.....	Filled.....	
	13	NW $\frac{1}{4}$ NW $\frac{1}{4}$	Anderson, C. M..	114	Jerry Mink...	1910	641	Dry.....	Filled.....	

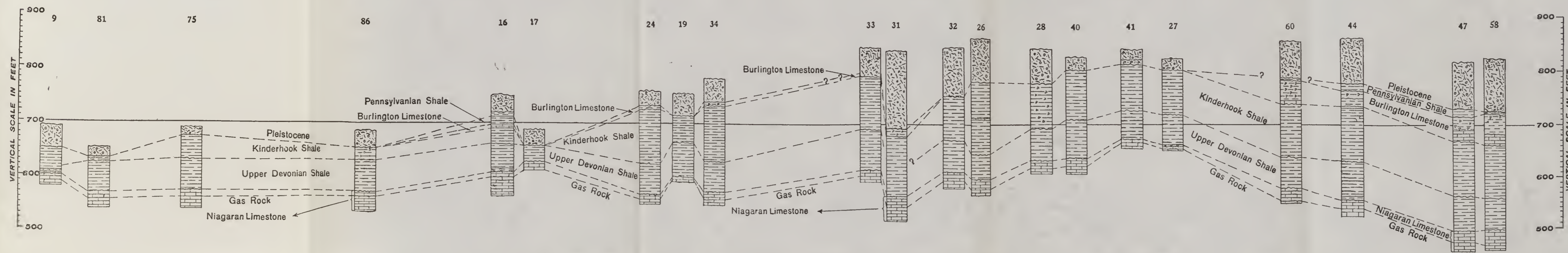
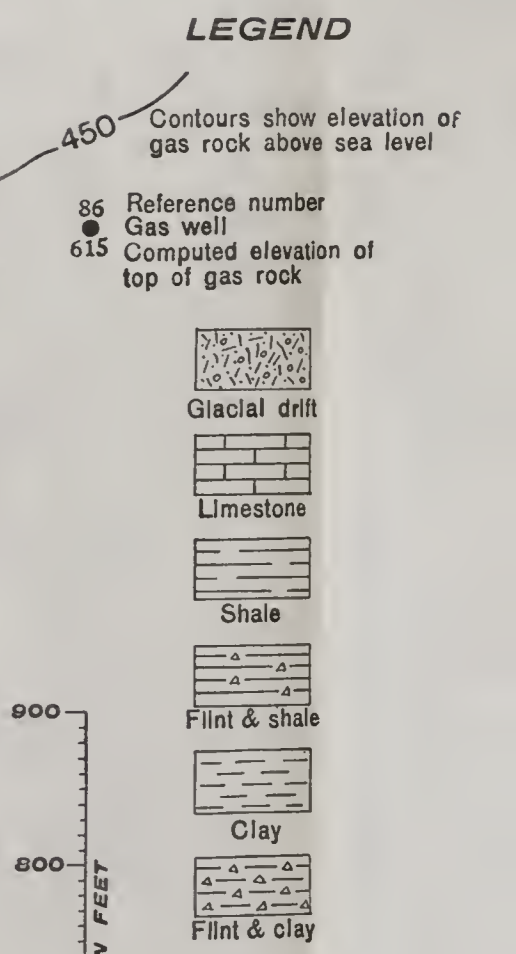
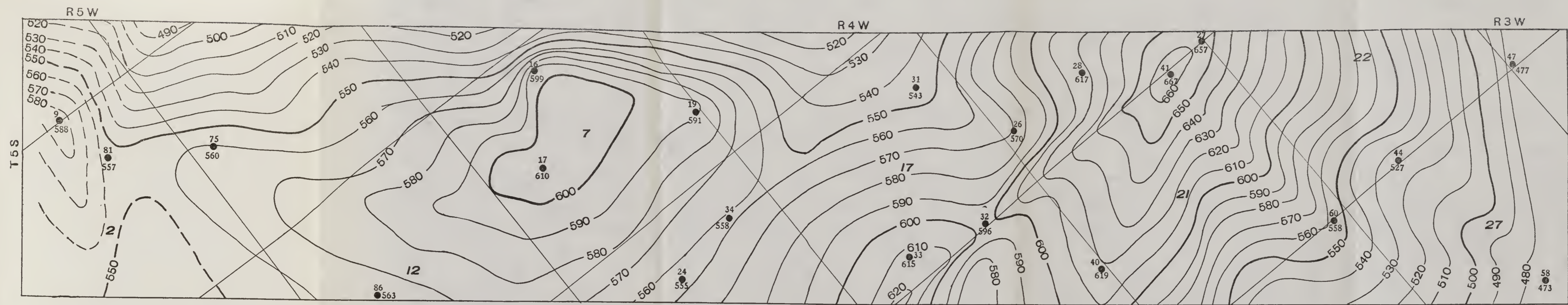

Map of the crest of the Pittsfield-Hadley anticline and columnar sections of the wells in the area

R 2 W

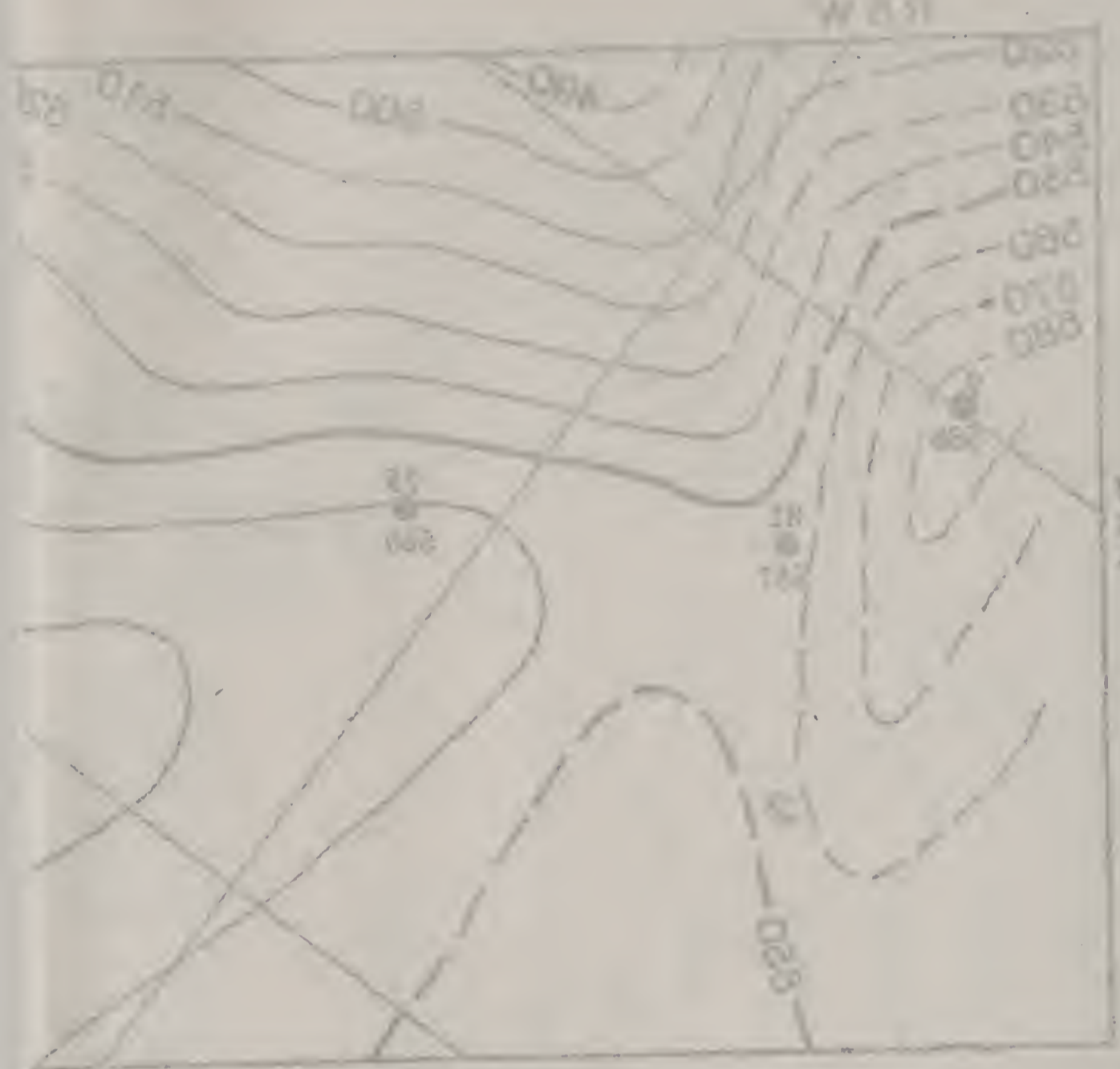

B 6 T

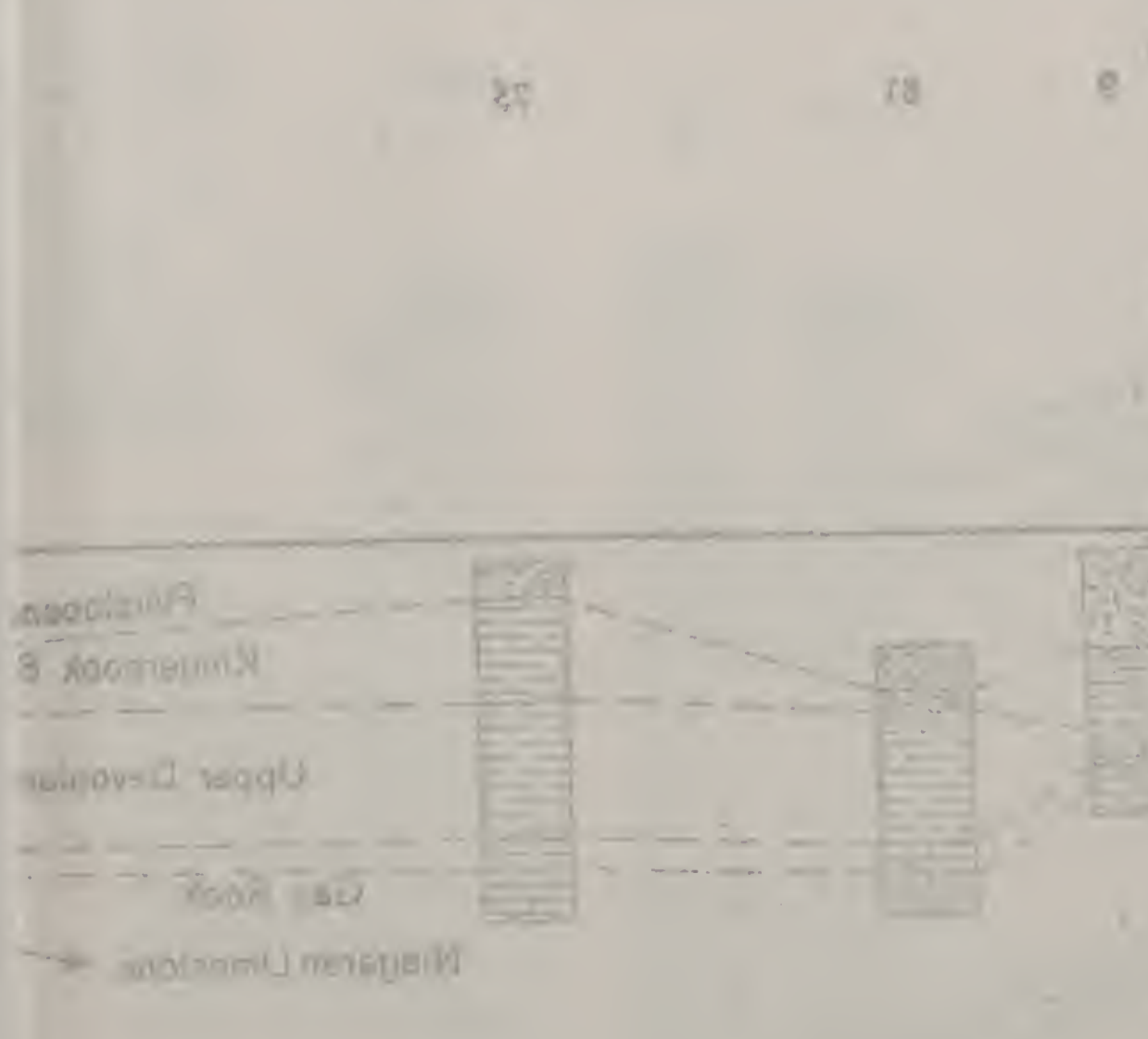
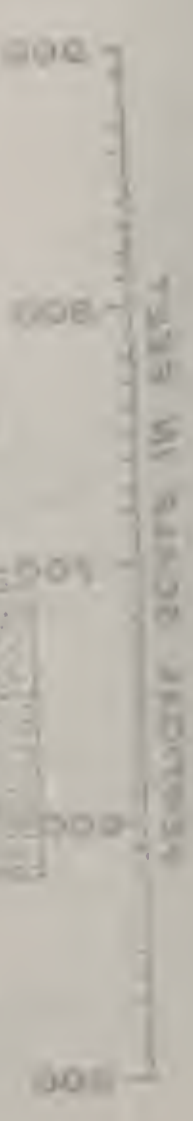

DESCRIPTION OF THE STRUCTURE

The results of the work show that in Derry and Pittsfield townships the strata are folded into a conspicuous anticline. The axis extends from the SW. cor. of sec. 21, T. 4 S., R. 5 W. (Hadley Twp.), to the SE. cor. of sec. 22, T. 5 S., R. 4 W. (Pittsfield Twp.) The crest is divided into four separate dome-like structures by three saddles, one in secs. 1 and 2, T. 5 S., R. 5 W. (Derry Twp.), another in secs. 17 and 18, and a third in secs. 17 and 20, T. 5 S., R. 4 W. (Pittsfield Twp.). The structure section (Plate IX, C-C) shows three of the domes and two of the synclines that lie upon the anticline. The crest of the dome farthest to the southeast is in the SE. $\frac{1}{4}$ sec. 16 and NE. $\frac{1}{4}$ sec. 21, T. 5 S., R. 4 W. (Pittsfield Twp.). Two of the strongest gas wells in the area are located on this dome. The gas rock is 667 feet above sea level in the well in section 21 (No. 41)¹. Toward the north the gas-producing bed dips 220 feet to the mile, and to the south 100 feet to the mile. The eastward dip is 180 feet for the first mile and 40 feet for the second. In the wells in the city of Pittsfield, 3 miles from the top of the dome, the gas rock is 410 feet above sea level. One mile west of the crest of the dome the gas rock lies in the bottom of one of the saddles where its elevation is 596 feet. One-fourth mile farther west in secs. 17, 18, and 20, T. 5 S., R. 4 W. (Pittsfield Twp.), the gas rock has an elevation of 614 feet. The crest of this low dome lies in the SW. $\frac{1}{4}$ section 17, the SE. $\frac{1}{4}$ section 18, and the NW. $\frac{1}{4}$ section 20. The southwest dip is 70 feet in the first mile but decreases to 25 feet in the second, forming a terrace in section 25, T. 5 S., R. 5 W. (Derry Twp.), which is less than one-half mile wide. The only producing well in the southern half of Derry Township is located on this terrace.

The gas sand in the syncline between the dome in sec. 17 and the one in sec. 7, T. 5 S., R. 4 W. (Pittsfield Twp.), is 555 feet above sea level. This is 55 feet lower than it is in either dome.

From the crest of the dome in the center of section 7, the gas rock dips 70 feet in the first quarter of a mile, and 30 feet in the second, toward the north. The non-productive area is only a mile from the crest of the dome in this direction. On the south slope where the dip is 60 feet to the mile, the productive area is much broader. The dip of the gas rock from section 7, toward the northwest along the crest of the anticline, is 40 feet to the mile. In the center of sec. 2, T. 5 S., R. 5 W. (Derry Twp.), the elevation is 557 feet above sea level. From the center of the NE. $\frac{1}{4}$ sec. 2, T. 5 S., R. 5 W. (Derry Twp.), to the center of the south line of sec. 35, T. 4 S., R. 5 W., (Hadley Twp.), the gas sand

¹ Well numbers refer to the reference numbers in Table 7.

rises 31 feet, but the information is not sufficient to determine the structure of the dome in detail.

Two and one-fourth miles west of Summer Hill is an incompletely defined structure which is probably a low dome. The gas sand in the productive well in sec. 10, T. 6 S., R. 5 W., (Atlas Twp.) is only 40 feet above the lowest known elevation of the sand in the syncline near New Hartford.

DEVELOPMENT

Gas was first discovered in Pike County in 1886, on the farm of Jacob Irick (F. G. Lewis, present owner), in sec. 1, T. 5 S., R. 5 W. (Derry Twp.), while drilling for water. The gas rock was entered at the depth of 186 feet. The well (No. 78) was cased and the gas was piped to the house, for which it has furnished an abundant supply since that time. Soon after the completion of the first well, a second one (No. 79) drilled for water on the same farm, "struck" gas at the depth of 168 feet.

No further attempt was made to develop the field until 1905, when William Irick put down a well (No. 78) on his farm in the SW $\frac{1}{4}$ sec. 1, T. 5 S., R. 5 W. (Derry Twp.), and piped gas from it to the farm buildings for heat and light.

During 1905 and 1906 two drillers, J. A. Clark and Jerry Mink, were constantly employed by the landowners who began to realize the advantage of the use of gas. Thirty wells were drilled in Derry and Pittsfield townships by June, 1906, six of them dry. Since then developments have progressed much more slowly. Of the few wells drilled each summer, some furnished abundant supplies of gas. By the close of the summer of 1912, one hundred wells had been drilled, thirty-nine of which are now non-productive. The wells drilled since that time were oil tests, promoted either by a corporation or by a group of enterprising landowners.

The initial pressure of the gas wells was not taken, but in almost every case the supply was more than was needed by the owner. It was noticed that the pressure was decreasing only when the demands exceeded the supply. In 1918 only those wells inclosed by the 590-foot contour (Plate IV) had sufficient gas supply for all seasons of the year. They are on the domes that lie on the anticlines. Between the 590-foot contour and the 500-foot contour the supply of gas is sufficient only for cooking and lights. A few wells near the 500-foot contour furnish enough gas for no more than one or two lights. The wells outside of the 500-foot contour are either non-productive or furnish such a meager supply of gas that they can be used only a few hours each day. On the southwest limb of the anticline in sec. 24, T. 5 S., R. 5 W. (Derry Twp.)

is a well (No. 87) that was productive until 1917. It lies upon the anticline above the 520-foot contour. Two wells in sec. 13, T. 5 S., R. 5 W., (Derry Twp.) are non-productive and lie between the 530-foot and 540-foot contours. In sec. 35, T. 4 S., R. 5 W. (Hadley Twp.), the well (No. 9) shown on the top of the dome is non-productive because of defects in casing. The field has been thoroughly exploited. The productive area is bounded on all sides by dry wells, and it is decreasing in size from year to year by failure of some of the wells that are near the margin.

THE GAS ROCK

The porous stratum forming the reservoir for the gas is a yellowish-brown dolomite, probably belonging to the Niagaran. Whenever the stratum was entered by the drill at an elevation above 500 feet, the well initially furnished an adequate supply of gas for farm use. This would indicate that the porous bed is present everywhere upon the anticline. The limestone above the gas rock, locally designated as the cap rock is only a few feet in thickness in most of the wells, and is overlain by the Kinderhook shale, which forms the impervious cover of the reservoir. The gas has very little odor and burns without smoke, giving a strong, bright flame. The following analysis is given by Professor T. E. Savage, who made an examination for the Geological Survey in 1906.¹

	Per cent
Carbon dioxide (CO ₂).....	.81
Oxygen (O ₂).....	3.46
Marsh gas (CH ₄).....	73.81
Nitrogen (N)	21.92
	<hr/>
Total	100.00

NOTES ON WELLS IN THE COLUMNAR SECTION SHEET (PLATE VI)

The accompanying areal map of the crest of the Pittsfield-Hadley anticline gives the location of twenty-one wells which were chosen to show graphically the stratigraphic sequence of the region, the thickness of the formations and the variations in the elevation of the gas rock upon the fold.

No. 58 is far down the slope of the southeast end of the anticline. The pressure was initially very weak, and the well is now abandoned.

No. 47 furnishes gas for one light.

No. 44 is one of the deepest wells in the area. It was drilled 18 feet into the gas rock.

¹ Savage, T. E., Pike County Gas Field: Ill. State Geol. Survey Bull. 2, pp. 77-87, 1906.

Nos. 41 and 27 are on top of the dome in section 16. They have furnished an abundance of gas since 1906.

Nos. 60, 26, 31, 32, and 40 are on the slope of the dome in sections 16, 17, and 21, but are well up on the crest of the anticline. They supply the farms on which they are located with sufficient fuel for light and heat.

No. 33 is a good well, located on a small dome in section 17. It was drilled during the spring of 1906.

The pressure in No. 24 has noticeably decreased. The supply is not sufficient for heat during the winter months. It is located in the bottom of the saddle that crosses the anticline in sections 17 and 18.

No. 17 is 76 feet deep. It is one of the shallowest and strongest wells in the area. It is located upon the top of the dome in section 7 and in the valley of a branch of Kiser Creek.

Nos. 16, 19, and 86 are good producing wells, located on the slope of the dome in section 7.

No. 75 is supplying gas for only one light.

No. 81 has a good pressure of gas, but it is not being used.

No. 9 was reported by Jerry Mink to contain considerable gas which was shut off by a strong flow of water.

STRUCTURES FAVORABLE FOR TESTING

The anticline in the northern half of T. 3 S., R. 5 W. (Beverly Twp., Plate V), is new territory for exploration for oil. Locations favorable for tests of the structure are chosen with reference to the structural conditions only. The sand in Schuyler County has been shown to be in disconnected lenses, and that characteristic may be true for this area. A well in the NE. $\frac{1}{4}$ sec. 5, T. 3 S., R. 5 W. (Beverly Twp.), would test the northwest end of the fold. The Hoing sand, which is the productive formation in the Colmar field, would be entered at the depth of 550 feet. To make the test complete, the drill should enter the Kimmswick-Plattin limestone which lies approximately 700 feet below the surface. The succession of strata that would be encountered is: Carbondale formation (shale), Pottsville formation (shale and sandstone), Salem limestone, Warsaw limestone, Keokuk limestone, Burlington limestone, Kinderhook group (shale), Upper Devonian shale, Niagaran limestone, Maquoketa shale, and Kimmswick-Plattin limestone.

The south~~west~~^{east} portion of the fold can be tested by drilling a well in sec. 10, T. 3 S., R. 5 W. (Beverly Twp.), preferably in the north half of the section. The depths to the Hoing sand horizon and the Kimmswick-Plattin limestone would be approximately as given in the above test.

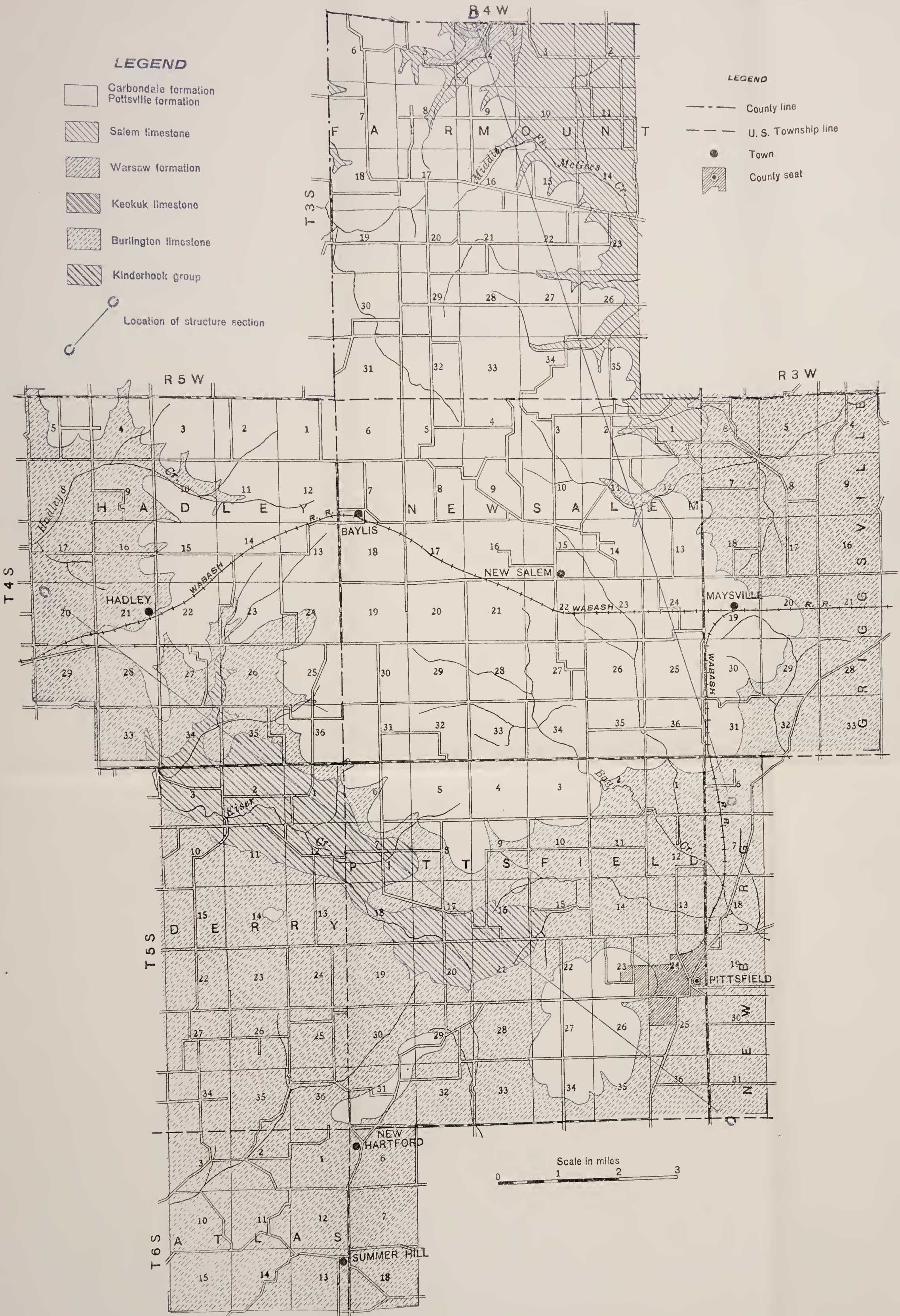

LEGEND

- Carbondale formation
Pottsville formation
- Salem limestone
- Warsaw formation
- Keokuk limestone
- Burlington limestone
- Kinderhook group

Location of structure section

LEGEND

- County line
- U. S. Township line
- Town
- County seat

Map of the areal geology of central and northern Pike County

In T. 3 S., R. 4 W. (Fairmount Twp., Plate IV), is a narrow terrace with a long northeast slope. Wells drilled near the northeast ^{west} corner of section 8 would test the top of the structure. The Hoing sand horizon would be entered at the depth of 490 feet and the Kimmswick-Plattin limestone at the depth of 680 feet. If it is found that the sand at the horizon of the Hoing sand in Schuyler and McDonough counties is in lenses, then other tests farther down the dip of the bed would be recommended.

The dome in the center of sec. 7, T. 5 S., R. 4 W. (Pittsfield Twp., Plate IV), is probably the best location in the gas area. A well drilled in this area would pass through the following beds before the Kimmswick-Plattin limestone is reached: Upper Devonian shale, Niagaran limestone, and Maquoketa shale. The total depth of the test would be approximately 260 feet. The McSorley gas well (No. 17) enters the Hoing sand horizon at the depth of 76 feet. No sand was reported.

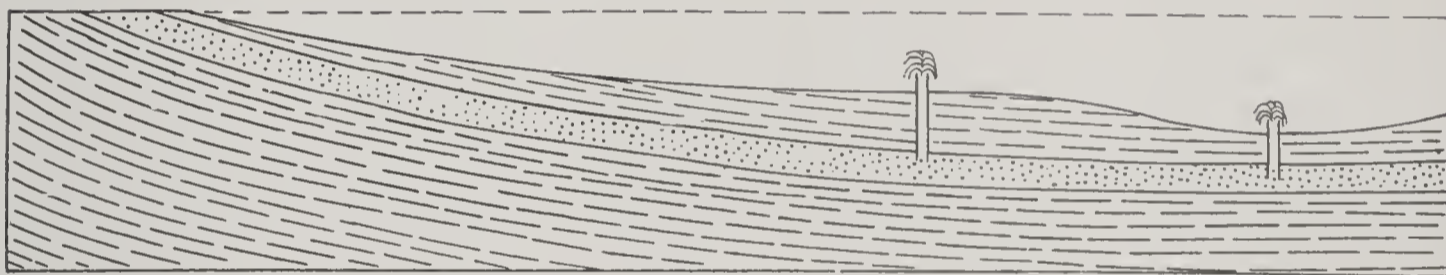

Fig. 16. Diagrammatic illustration of conditions favorable to artesian wells.

The dome in the SW. $\frac{1}{4}$ sec. 17, T. 5 S., R. 4 W. (Pittsfield Twp., Plate IV), would be tested by a well drilled in the south half of the quarter section. The succession of beds is the same as that above, with the addition of the Kinderhook shale, which lies upon the Upper Devonian shale. The test would enter the Kimmswick-Plattin limestone at the depth of 450 feet.

The dome in the NE. $\frac{1}{4}$ sec. 21, T. 5 S., R. 4 W. (Pittsfield Twp.), has probably been tested by the deep well in the NW. $\frac{1}{4}$ of section 21, but since the gas rock is 30 feet lower in the test well than on the crest of the dome, which is one-half mile east, it is recommended that another well be drilled in the NE. $\frac{1}{4}$ of section 21, in order to test the fold completely. The Kimmswick-Plattin lies approximately 400 feet below the surface.

The terrace extending southwest from the anticline in section 21 can be tested by wells in the south half of sec. 19, T. 5 S., R. 4 W. (Pittsfield Twp.), and sec. 25, T. 5 S., R. 5 W. (Derry Twp.) The Kimmswick-Plattin limestone would be entered at the approximate depth of 420 feet.

FLOWING WATER WELLS

Flowing water wells depend on certain relations of rock structure, water supply, and elevation (fig. 16). A flowing well is possible in any place underlain by a bed of porous rock of considerable thickness beneath an impervious layer, if the porous bed outcrops over a rather wide stretch of territory in a region of higher elevation and adequate rainfall. The structure section (Plate IX, A-A) through the basin in which the Luther Rice flowing well is located, shows a part of these conditions. In this well the Niagaran limestone forms the porous water-bearing stratum beneath the impervious Kinderhook shale. The Niagaran beds outcrop near Mississippi River several miles to the southwest, and receive their supply of water from the rains in that region.

STRATIGRAPHY

GENERAL STATEMENT

The rocks of the area consist of unconsolidated and consolidated types. The unconsolidated are alluvium, loess, and drift; the consolidated, shales, sandstones, coals, and limestones.

UNCONSOLIDATED ROCKS

ALLUVIUM

The alluvium occurs in stream valleys. It consists of glacial till, loess, and residual clay, reworked by running water. The sand constituent is high, and the amount of humus low. The thickness varies from a few feet to twenty or more.

LOESS

Covering the glacial drift in many places is a dust-like deposit known as loess. The similarity of its mineral composition to that of glacial drift may indicate that it is drift, reworked by water and wind. The history of its transformation into loess begins with transportation of drift material beyond the edge of the ice sheet by the streams flowing from the glacier, and its deposition upon the flood plains. After the retreat of the glacier the streams decreased in size, and the flood plains became dry, permitting the fine material to be picked up by the wind and deposited over the uplands. Its greatest thickness in this area varies from a few feet to 10 feet.

DRIFT

The heterogeneous deposit of clay, gravel, and boulders, which lies beneath the loess is known as drift and belongs to the Illinoian period

of glaciation. The thickness varies from a few feet on the upland to 30 or more feet in the valleys of the pre-Illinoian land surface. It is present everywhere in the area except where streams have removed it and have cut their valleys deep into the consolidated rocks. The rock fragments in the drift consist of many kinds picked up by the ice sheet from the various deposits over which it passed.

In places extensive pockets of sand were deposited by the melting ice as in the SW. $\frac{1}{4}$ sec. 29, T. 5 S., R. 4 W. (Pittsfield Twp.), where a sand lens has a thickness of 28 feet. Lenses of gravel outcrop in many of the valley slopes, as in the NW. $\frac{1}{4}$ sec. 27, T. 1 S., R. 6 W. (Columbus Twp.) Masses of coal are found mingled with the clay, sand, and gravel of the drift, in sec. 29, T. 4 S., R. 3 W. (Griggsville Twp.). The predominance of shale particles and limestone fragments everywhere in the drift gives evidence that the major portion of the deposit has been derived from the shales and limestones in the adjacent region.

CONSOLIDATED ROCKS

GENERALIZED SECTION

		<i>Key bed numbers refer to the list of key horizons given on a previous page</i>	
		Thickness	
		<i>Feet</i>	<i>inches</i>
Pennsylvanian system			
Carbondale formation			
37.	Shales, light blue, sandy, in layers varying in thickness from $\frac{1}{2}$ inch to 2 inches, and separated by thin seams of sand. The lower 6 to 8 inches consists of black shale.....	30	..
36.	Coal, in lenses (key bed No. 7).....	1	4
35.	Shale; the upper 4 feet is bluish, streaked with ferrous oxide, and contains many stringers of coal. The lower 8 feet is blue, soft clay shale	12	..
34.	Limestone, dark gray, nodular, crystalline (key bed No. 6)	3	6
33.	Shale, light blue, micaceous, sandy, in thin beds..	53	..
32.	Limestone, bluish, shaly, fossiliferous. <i>Productus</i> and <i>Chonetes</i> shells are abundant (key bed No. 5)	3
31.	Shale, light blue, sandy, containing many small nodules of limestone.....	4	..
30.	Limestone, a band of large septarian concretions of dense bluish limestone, the crack filled with calcite crystals (key bed No. 4).....	3	..
29.	Shale, blue, sandy, with seams of pyrite.....	4	..
28.	Shale, fissile, black.....	..	10
27.	Coal, Colchester (No. 2) (key bed No. 3).....	1	6

		Thickness	
<i>Consolidated Rocks—Continued</i>		<i>Feet</i>	<i>inches</i>
Pottsville formation			
26.	Shale, bluish, sandy.....	24	..
25.	Limestone, dolomitic, crystalline, brown.....	1	3
24.	Shale, bluish, sandy, interbedded with thin beds of sandstone	5	6
Mississippian system			
St. Louis limestone			
23.	Limestone, bluish gray, brecciated, dense.....	3	..
22.	Limestone, thin bedded, gray, crystalline.....	1	6
21.	Shale, light green.....	..	6
20.	Limestone, dolomitic, brown, crystalline.....	4	6
19.	Shale, greenish	4	..
18.	Limestone, brecciated, dense, bluish.....	6	..
17.	Shale, green	1/2
16.	Limestone, bluish gray, shaly, dense.....	8	..
15.	Shale, light green.....	..	1/2
Salem limestone			
14.	Limestone, fossiliferous, dove colored, containing numerous protozoans (top of formation is key bed No. 2).....	10	..
13.	Limestone, shaly	17	..
12.	Limestone, brown, dolomitic.....	14	..
Warsaw formation			
11.	Shale, soft, interbedded with thin layers of fossiliferous limestone. Bryozoans are abundant.....	28	..
10.	Limestone, dolomitic, interbedded with shale.....	21	..
Keokuk limestone			
9.	Limestone, thinbedded, interbedded with layers of chert and shale, having a thickness varying from 1 to 4 inches. Limestone contains many fragments of crinoids and bryozoans. Brachiopods are abundant	24	..
Burlington limestone			
8.	Limestone, interbedded with thin layers of chert. The limestone contains abundant plates and segments of crinoids.....	86	..
Kinderhook group			
7.	Shale, light blue, compact, with lenses of sandstone and thin beds of limestone.....	122	..
Devonian system			
Upper Devonian shale			
6.	Shale, brown, calcareous.....	60	..
Silurian system			
Niagaran limestone			
5.	Limestone, dolomitic, gray, hard, dense ("cap rock" of the drillers).....	14	..
4.	Limestone, porous, dolomitic (gas rock, key horizon No. 1)	24	..

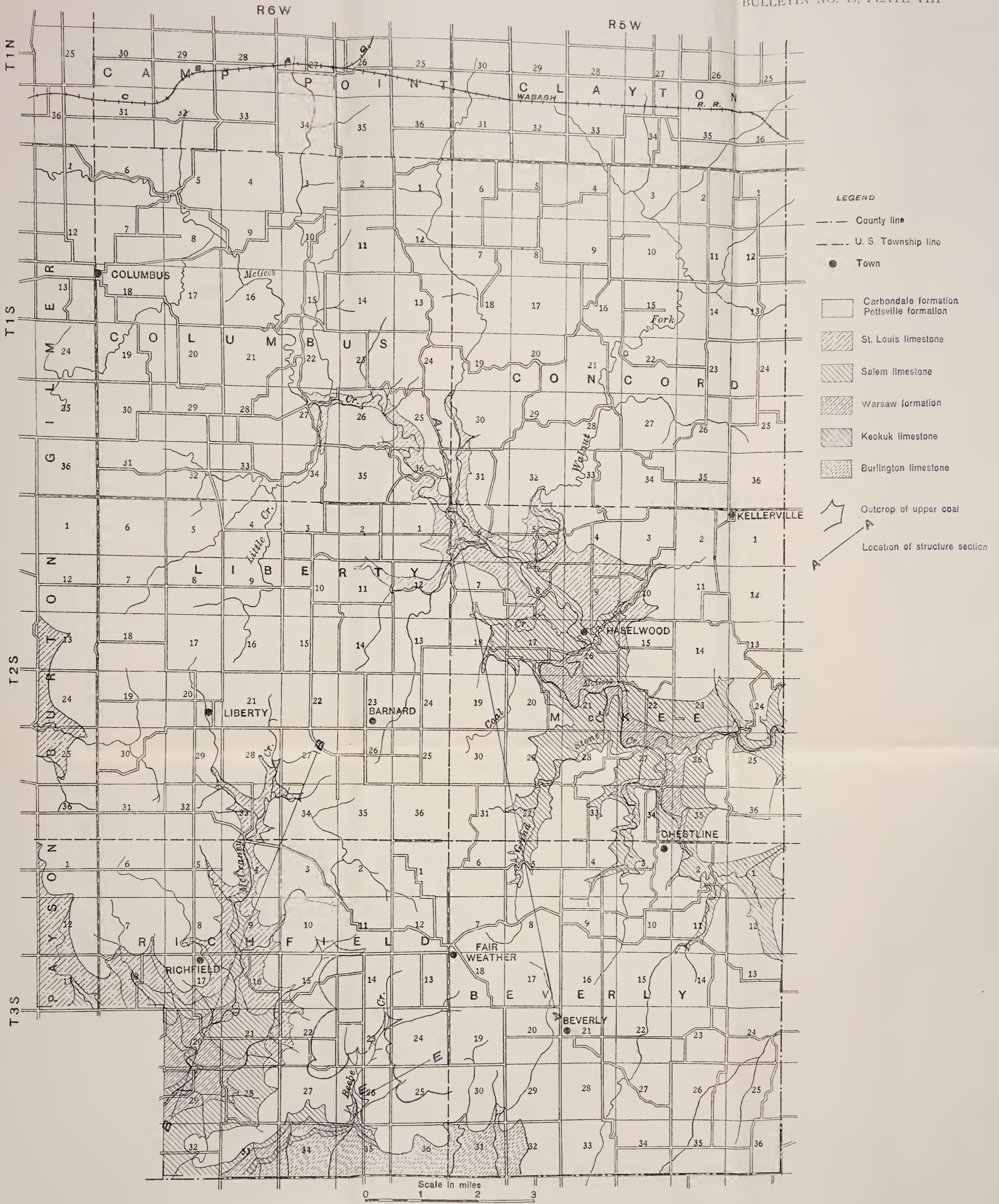

Map of the areal geology of southeastern Adams County

Consolidated Rocks—Concluded

Ordovician	Thickness	
	<i>Feet</i>	<i>inches</i>
Maquoketa shale		
3. Shale, greenish blue, with limestone beds near the base	166	..
Kimmswick-Plattin limestone		
2. Limestone, dolomitic, white and gray.....	295	..
St. Peter sandstone		
1. Sandstone, hard, gray, and brown (Total thickness in the area is unknown. Well No. 113 enters the formation to the depth of 95 feet 6 inches).....

PENNSYLVANIAN SYSTEM

CARBONDALE FORMATION

The Carbondale formation includes all the beds lying between the top of No. 6 coal and the base of No. 2 coal. Only the lower part of the formation occurs in this area. The upper beds were not deposited or were removed during the period of erosion that followed the deposition of the Pennsylvanian rocks in western Illinois, and preceded the advance of the Illinoian ice sheet. The greatest thickness of the Carbondale formation is in the northern part of the area in Adams County (Plate VIII). In the wells near Clayton, it has a thickness of 150 feet. In T. 3 S., R. 6 W. (Richfield Twp.), it has the average thickness of 115 feet. On the north limb of the Pittsfield-Hadley anticline (Plate IV) four miles south of Baylis, the total thickness of the Carbondale is only five feet.

The highest beds of the formation in this area are exposed in the stream valleys near Columbus and Camp Point, and on the highest hills in T. 3 S., R. 5 and 6 W., (Beverly and Richfield townships, Plate VIII), for example in the SW. $\frac{1}{4}$ sec. 27 of Richfield Township. They consist of light blue, sandy shales in layers varying in thickness from one-half inch to two inches, and are separated by thin seams of sand. Thirty feet is the greatest thickness exposed in a single section.

Beneath this shale and seventy-five feet above the base of the Carbondale formation is a bed of coal consisting of numerous small lenses varying in thickness from a few inches to several feet (figure 17) and overlain by 6 to 8 inches of black shale similar to that above Colchester (No. 2) coal. The underclay is bluish, streaked with yellow, and contains many thin seams of coal. Lenses of the coal bed in secs. 10, 14, 22, 24, and 25, T. 3 S., R. 6 W., have been mined by stripping. The coal stratum has been traced only in T. 3 S., R. 6 W. (Richfield Twp.)

Below this lies a 12-foot bed of soft, blue, calcareous shale. Near the base many small nodular masses of limestone occur.

The bed of limestone beneath the shale is a brown nodular formation showing an average thickness of three feet, and carrying a high percentage of clay. The best exposures are in secs. 14, 22, and 24, T. 2 S., R. 6 W. (Liberty Twp., Plate VIII), and secs. 19 and 31, T. 2 S., R. 5 W. (McKee Twp., Plate VIII).

Near the center of sec. 31, T. 2 S., R. 5 W. (McKee Twp., Plate VIII), is a splendid outcrop of the thick deposit of shale which underlies the nodular limestone. It is a light-blue, micaceous, sandy shale, in layers varying from a fraction of an inch to 4 or more inches, which are separated by sandy seams. The formation weathers rapidly, and talus debris covers the bases of all the bluffs in which it is exposed. The maximum thickness measured is 53 feet.

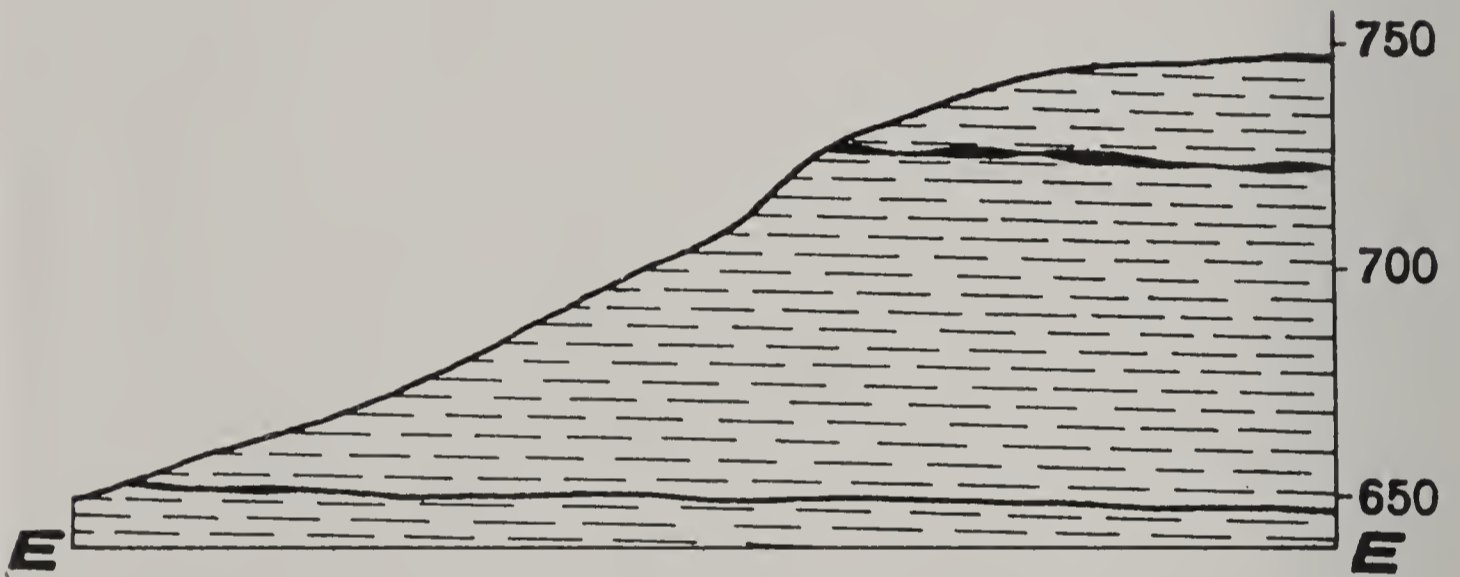

Fig. 17. Diagrammatic cross section showing the upper coal bed (key horizon No. 7) in lenses at 725 feet and Colchester (No. 2) coal (key horizon No. 3) just below 650 feet above sea level. The location of this section is shown as E-E on Plate VIII.

A very persistent, impure, fossiliferous limestone lies beneath the thick shale deposit and 10 to 15 feet above the Colchester coal. The fossils are principally *Productidae* shells. It has a thickness of 3 inches in the section along the stream in the west half of sec. 8, T. 3 S., R. 6 W. (Richfield Twp., Plate VIII).

Four feet of light-blue, sandy shale lies between the fossiliferous bed and the horizon of the septarian concretions. The shale contains many small concretion-like nodules, arranged parallel to the stratification.

The septarian concretions resemble crushed spheres of dark-blue limestone, with the cracks formed by the stress filled with crystals of calcite. They lie in a band 6 to 8 feet above the top of the Colchester coal.

The next 7 feet of shale below the concretions is a dark-blue, carbonaceous deposit, containing many seams of pyrite.

Between the bed of shale above and the Colchester coal beneath is a bed of black fissile shale with an average thickness of 10 inches.

The Colchester coal and the black shale immediately above are in a few places the only representatives of the Carbondale formation, as in sec. 22, T. 5 S., R. 4 W. (Pittsfield Twp., Plate VII). In most of the pits, banks, tunnels, and exposures in the bluffs of the streams, the thickness of the coal varies from 18 to 24 inches. In sec. 28, T. 3 S., R. 6 W. (Richfield Twp., Plate VIII), and sec. 10, T. 4 S., R. 5 W. (Hadley Twp., Plate VII), the coal has a thickness varying from 8 to 11 feet.

POTTSVILLE FORMATION

The Pottsville formation underlies the Colchester (No. 2) coal conformably. Its thickness varies from 30 to 40 feet in T. 1 S., Rs. 5 and 6 W. (Concord and Columbus Twps., Plate VIII), to a few feet in T. 5 S., R. 4 W. (Pittsfield Twp., Plate VII). The following is a section measured on the bluff of a stream, in the SE. cor. NW. $\frac{1}{4}$ sec. 5, T. 3 S., R. 4 W. (Fairmount Twp., Plate VII).

Section of strata northwest of Chestline

	<i>Feet</i>	<i>Inches</i>
Carbondale		
3. Colchester coal	1	6
Pottsville		
2. Shale, yellowish, sandy.....	4	..
1. Shale, bluish green, sandy.....	10	..
Base not exposed.		

A section measured in the NW. cor. SE. $\frac{1}{4}$ NE. $\frac{1}{4}$ sec. 33, T. 2 S., R. 5 W. (McKee Twp., Plate VII), is as follows:

Section of strata northeast of Fair Weather

	<i>Feet</i>	<i>Inches</i>
Carbondale		
4. Colchester coal	1	2
Pottsville		
3. Shale, bluish	24	..
2. Limestone, brown	1	3
1. Shale, bluish, sandy.....	5	6
Salem limestone. Base not exposed.		

The variation in thickness is probably due to the irregularities of the surface upon which the Pottsville was deposited.

The rocks of the Pennsylvanian system lie immediately beneath the drift over 78 square miles in the central and northwestern part of the area in Pike County, and over almost all the area in Adams County represented by Plate VIII, except along the southwest border and in the valleys of the larger streams. Outliers of the Pennsylvanian sediments lie upon the limbs of the anticline in the gas area, between Pittsfield and Hadley (Plate VII).

MISSISSIPPIAN-PENNSYLVANIAN UNCONFORMITY

After the deposition of the St. Louis limestone, western Illinois was drained of its sea and remained land until the invasion of the Ste. Genevieve sea, which extended up the Mississippi valley into Iowa. The invasions of the Chester sea did not extend so far north, and probably did not cover Pike and Adams counties in Illinois. During the long period that intervened between the retreat of the Ste. Genevieve sea and the deposition of the Pottsville sediments, the area described in this paper was above the sea and subjected to the agencies of erosion. The St. Genevieve formation was eroded completely from the area, and the St. Louis and Salem formations were removed from much of the area south of their present boundaries (Plates VII and VIII).

MISSISSIPPIAN SYSTEM

The Chester group and the Ste. Genevieve limestone are absent. The rocks of the Meramec, Osage, and the Kinderhook groups outcrop in the area. The Meramec group includes the Salem and St. Louis limestones. The Osage group includes the Warsaw formation, the Keokuk limestone, and the Burlington limestone. No attempt was made to differentiate the members of the Kinderhook group.

ST. LOUIS LIMESTONE

The St. Louis limestone is the surface formation over approximately 16 square miles in the valleys of McGees, McCraney, and Mill creeks (Plate VIII). Along McGees Creek the formation disappears near Hazelwood, and the overlying Pennsylvanian shale is in contact with the Salem limestone (Plate IX, B-B). In the valley of McCraney Creek the St. Louis extends much farther south. The best exposures of the formation are along this creek in secs. 4, 9, and 17, T. 3 S., R. 6 W. (Richfield Twp., Plate VIII). The St. Louis is essentially a brecciated, bluish-gray limestone, very brittle and compact. The angular fragments vary in size from minute particles to masses several feet in diameter. Between the strata of limestone are seams and beds of greenish clay. The formation has an average thickness of 20 feet along McCraney Creek. The thickness increases down the dip, and from the well of Russel Davis in sec. 25, T. 1 N., R. 5 W. (Clayton Twp.), 150 feet of St. Louis is reported. Fossils are very rare in the limestone layers except locally, where numerous masses of *Lithostrotion* occur. Many of these fossils were weathered out of the limestone before the deposition of the Pottsville and have become imbedded in the base of that formation as in sec. 5, T. 2 S., R. 5 W. (McKee Twp., Plate VIII).

The following is a section of the St. Louis measured from a bluff near the stream in the NW. cor. sec. 5, T. 2 S., R. 5 W.

Section of strata northwest of Hazelwood

	<i>Feet</i>	<i>Inches</i>
Recent		
11. Soil	2	..
St. Louis		
10. Limestone, bluish gray, brecciated, dense.....	3	..
9. Limestone, thin bedded, gray, crystalline.....	1	6
8. Shale, light, green.....	..	6
7. Limestone, dolomitic, brown, crystalline.....	4	6
6. Shale, greenish	4	..
5. Limestone, bluish, brecciated, dense.....	6	..
4. Shale, green	1/2
3. Limestone, bluish gray, shaly, dense.....	8	..
2. Shale, light green.....	..	1/2
Salem		
1. Limestone, dolomitic, massive, brown crystalline.		
Base covered	5	..

SALEM LIMESTONE

The Salem limestone lies unconformably below the St. Louis limestone. It outcrops in the valleys of McCraney and McGees creeks, and in the eastern part of T. 3 S., R. 4 W. (Fairmount Twp., Plate VII). It overlaps the Warsaw and Keokuk and in central Pike County (Plate VII) lies upon the Burlington limestone. The lower beds of the Salem formation, which are present in Brown and northern Pike counties, are absent in the southern part of T. 3 S., R. 4 W. (Fairmount Twp). Central Pike County was probably land during the early Salem time.

Fossils are locally abundant, consisting of numerous shells of protozoans and fragments of bryozoans.

The formation has a thickness of 41 feet along McGees Creek and decreases southward, completely disappearing in the northeast part of T. 4 S., R. 4 W. (New Salem Twp., Plate VII), where the Pennsylvanian shales lie upon the Burlington limestone.

WARSAW-SALEM UNCONFORMITY

After the deposition of the Warsaw, there was a prolonged period of erosion during which the Warsaw and Keokuk beds were probably eroded from much of the Pike County area (Plate VII), leaving the Burlington limestone as a surface formation at the beginning of the Salem time (Plate IX, D-D). This unconformity is the basis for the division of the Mississippian limestones in this area into the Osage and Meramec groups.

WARSAW FORMATION

The upper part of the Warsaw formation consists predominantly of soft, calcareous shale, interbedded with thin crystalline limestone

strata. The limestones are very fossiliferous, containing many shells of brachiopods and remains of bryozoan colonies. *Lioclema* and *Archimedes* are abundant. The lower part of the Warsaw formation consists of a series of dolomitic limestone, interbedded with shales. The limestones are compact, light gray, and contain only a few fossil remains, which are mostly fragments of bryozoans.

This formation outcrops along McCraney and McGees creeks (Plates VII and VIII). The contact between the Warsaw and Keokuk is not sharply defined, and the faunal characteristics of the two formations are very similar. There appears to be no cessation in deposition and no distinct break in the succession of the life of the two formations to suggest an unconformity. In a section measured along McGees Creek, in sec. 4, T. 3 S., R. 4 W. (Fairmount Twp., Plate VII), the Warsaw has a thickness of 49 feet.

KEOKUK LIMESTONE

The Keokuk limestone is exposed along McGees (Plate VII) and McCraney creeks (Plate VIII). It consists of fossiliferous limestones and shales interbedded with layers of cherty limestone. The shaly layers are filled with fragments of bryozoans. Brachiopods and crinoids are abundant in the limestone beds. *Echinoconchus alternatus*, *Productus magnus*, *Agaricocrinus tuberosus*, and several genera of *Spirifera* were collected from the exposure of the limestone in the NW. $\frac{1}{4}$ sec. 4, T. 3 S., R. 4 W. (Fairmount Twp.) The Keokuk has a thickness of 24 feet in this locality.

BURLINGTON LIMESTONE

Burlington limestone is the surface formation near the southern boundary of the area in Adams County (Plate VIII) and over a considerable portion of the eastern, southern, and western parts of the area in Pike County (Plate VII). It varies in thickness from 6 feet on the crest of the Pittsfield-Hadley anticline to 100 feet in the Sam Bradshaw well, NW. cor. NE. $\frac{1}{4}$ sec. 4, T. 4 S., R. 3 W. (Griggsville Twp., Plate VII).

The formation consists of alternating beds of limestones and cherts. The limestones are conspicuously crinoidal, consisting almost entirely of separated plates and column segments. *Productus burlingtonensis* is present in considerable abundance. The cherty beds make up approximately fifty per cent of the formation. In many of the wells upon the anticline in the gas area of Pike County, the Burlington limestone is represented only by cherty layers.

ILLINOIS STATE GEOLOGICAL SURVEY

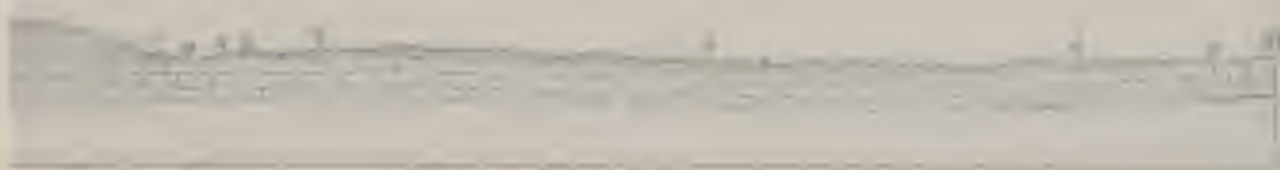

Scale 1/4 inch = 1 mile

KINDERHOOK GROUP

Shales and thinly bedded sandstones of the Kinderhook group outcrop upon the anticline in central Pike County (Plate VII). The thickness varies from a few feet to a maximum of 122 feet, observed in the well of Claude Shinn in the SE. cor. sec. 36, T. 5 S., R. 5 W. (Derry Twp., Plate VII). The formation is probably absent over the central portion of section 7 (Plate IX, C-C, well No. 17, and Plate VI).

DEVONIAN SYSTEM

UPPER DEVONIAN SHALE

Between the Kinderhook shale and the "second lime" occurs 60 feet of dark-brown, calcareous shale, which is referred to as the Upper Devonian, and known in this area only from well records. Upon the basis of the interpretation of the log of the gas well (No. 17, Plate VI), one-fourth of a mile west of the center of sec. 7, T. 5 S., R. 4 W. (Pittsfield Twp.), it is the surface formation over a small area in the valley of Kiser Creek. No attempt has been made to define the limits of the outcrop on the map of the areal geology. (See Plate IX, C-C.)

SILURIAN SYSTEM

NIAGARAN LIMESTONE

Niagaran limestone lies below the brown shale. Only a few of the wells pass through the formation into the Maquoketa shale beneath. The upper part of the formation is a white, hard, compact, dolomitic limestone, locally called the "cap rock;" the lower portion is a brown dolomite and contains the gas in Pike County. The thickness, as determined from the oil test in sec. 36, T. 5 S., R. 5 W. (Derry Twp.), is 38 feet. The Hoing sand, probably derived from reworked material, is locally deposited upon the irregular surface of the Maquoketa formation, and forms the base of the Niagaran.

ORDOVICIAN SYSTEM

MAQUOKETA SHALE

In the well (No. 113), drilled by the Summer Hill Light and Fuel Company in sec. 12, T. 6 S., R. 5 W. (Atlas Twp.), 166 feet of greenish shale was encountered below the Niagaran limestone. This shale has been correlated with the Maquoketa shale of northern Illinois.

KIMMSWICK-PLATTIN LIMESTONE

The Kimmswick-Plattin limestone consists of beds of white and gray limestone. The formation has a thickness of 295 feet in the well (No. 113) drilled by the Summer Hill Light and Fuel Company. In the outcrops in Calhoun County the formation is composed largely of shells. A show of oil is reported from these beds in many parts of Illinois.

EXPERIMENTS IN WATER CONTROL IN THE FLAT ROCK POOL, CRAWFORD COUNTY

By Fred B. Tough, Samuel H. Williston and T. E. Savage

In cooperation with the U. S. Bureau of Mines

OUTLINE

	PAGE
Introduction.....	99
Summary.....	99
Purpose of the work.....	99
Results of corrective work.....	101
Permanency of results.....	101
Decline curves.....	101
Acknowledgments.....	104
Statement of problem.....	104
Selection of Flat Rock pool for experimental work.....	106
Geology.....	106
General statement.....	106
Geologic section.....	107
Quaternary system.....	107
Pennsylvanian system.....	107
Pottsville formation.....	110
Carbondale formation.....	110
McLeansboro formation.....	110
Producing sands.....	111
The 600-foot gas sand.....	111
Structure.....	111
Upper salt sand.....	111
Flat Rock sand.....	112
Structure.....	113
Oil characteristics.....	114
Water characteristics.....	114
Investigation prior to recommendation.....	118
Peg model.....	118
Graphic logs.....	121
Preliminary gaging.....	121
Method of recording data.....	124
Ratio.....	128
Recommendations for repair work on wells.....	128
Gaging after repairs.....	129
Loss of production incident to delay in repairs on wells.....	129
Testing to determine source of incoming water.....	131
Use of Venetian red as an indicator.....	131
Use of packers as testing devices.....	131

Outline—Continued

	PAGE
Methods of water control.....	131
Use of mud fluid.....	131
The mud	133
Methods of mudding wells.....	134
Suggestions with regard to casing.....	136
Application to repair problems.....	137
Corrosion of casing and methods of prevention.....	137
Intermediate water and its control.....	138
Use of cement.....	139
McDonald method of cementing bottom water.....	140

ILLUSTRATIONS

PLATE		PAGE
X.	Map showing structure on the surface of the 600 foot "gas sand" in a portion of the Flat Rock pool.....	110
XI.	Map showing structure on the surface of the Flat Rock sand in a portion of the Flat Rock pool.....	114
XII.	Map showing water and oil production and the water-oil ratio of wells in a portion of the Flat Rock Pool; the map also shows leases	128
FIGURE		
18.	Diagram showing rise and decline of oil production in Illinois, 1905-1918	100
19.	A. Diagram showing the production of oil and water for Ewing well No. 8, Selby-Cisler Producing Company, beginning immediately after cementing	
	B. Diagram showing the production of oil and water for Ewing well No. 8, same company, beginning immediately after packer was set.....	102
20.	Photograph of a casing corroded by water in the Flat rock pool	105
21.	Map showing contours on Beaumé oil gravities. The lighter oils are in the higher parts of the structure. (Compare Plates X and XI.).....	115
22.	Photograph of the peg model, used in the field to represent sub-surface conditions	119
23.	A graphic log typical of those used in studying wells with sub-normal production.....	120
24.	Photograph of a single-barrel gage setup used early in the work..	123
25.	Diagram showing in detail the plan of the single-barrel gage in a setup.....	123
26.	Photograph of the three-barrel siphon gage setup in operation..	124
27.	Diagram showing in detail the plan of the three-barrel siphon gage setup. The apparatus is shown on the tank rather than beside it as in the photograph (figure 26) of a similar setup.....	125
28.	Sample record sheet as used in gaging.....	126
29.	Lease sheet showing gage averages.....	126
30.	Photograph of the gage board devised for protection of the records while in use on the lease.....	127

Illustrations—Concluded

	PAGE
31. Diagram to show the saving in casing accomplished by the use of mud fluid.....	132
32. Photograph showing the connection at the top of the well between the discharge of the mud pump and the casing in the circulation method. The outcoming mud fluid has been forced down through the casing, out its bottom, and is returning to the surface, outside the casing.....	133
33. Diagram showing the system used in collecting mud for mudding Selby-Cisler well, Ewing No. 6B.....	135
34. Photograph of the mud sump taken from the top of the derrick on Selby-Cisler well, Ewing No. 6B.....	137
35. Photograph of the mud sump looking toward the derrick. Trench near the center in which coarse material settles out; suction and mixing pipes at the right the former below the latter..	139

TABLES

8. Results of corrective work.....	103
9. Analyses of water from oil wells in the Flat Rock Pool.....	116
10. Summary of recommendations for repairs to wells.....	130

INTRODUCTION

The phenomenal development of petroleum in the State of Illinois between the years 1905 and 1910 and the subsequent decline is strikingly shown in the curves of figure 18. It is this alarming decline in the amount of crude oil produced yearly that constitutes the most serious problem confronting the oil industry of the commonwealth. Besides the total production of the State, the curves included in figure 18 show the relative productivity of the various pools. It will be noted that the total State production for the year 1917 was nearly 4,000,000 barrels less than the amount extracted from the Lawrence County pool alone in the year 1911, and about 3,000,000 barrels less than the yield from the Crawford County pool in 1908.

SUMMARY

PURPOSE OF THE WORK

The fundamental purpose of the present work is to combat this enormous decline of oil production in Illinois. Pursuant to this end it was determined to make an intensive study of a small area in one of the oil fields of the State, with the hope that the results attained might encourage an extension of similar work throughout the State. The methods of gaging wells and of applying data to the various problems encountered are given in considerable detail, as it is thought that such information might be of use to operators conducting a study of similar problems. It is also hoped that the State and Federal governments will

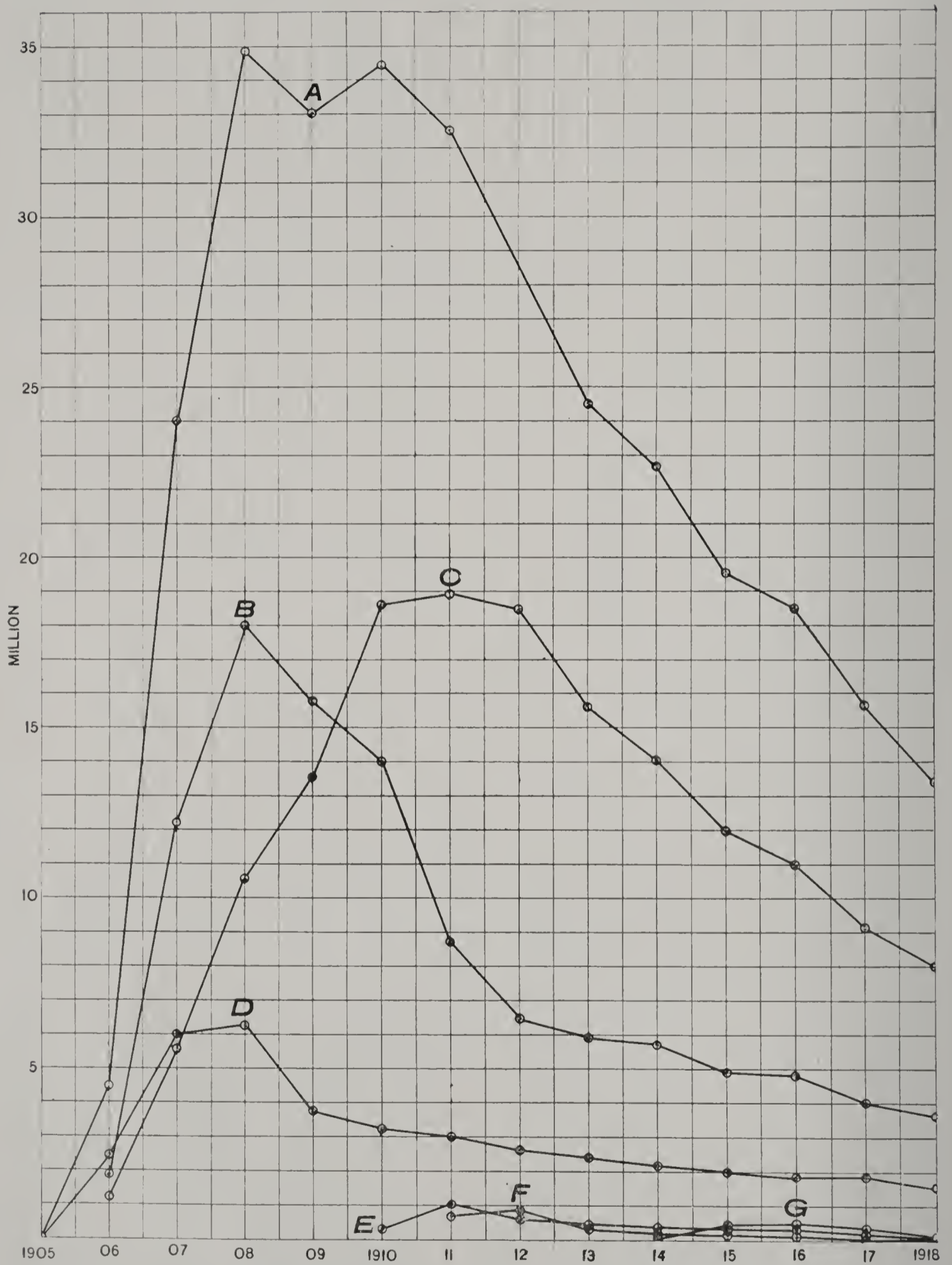

Fig. 18. Diagram showing rise and decline of oil production in Illinois, 1905-1918, expressed in barrels of 42 gallons.

A. Total for State.
 B. Crawford Co. Pool.
 C. Lawrence Co. Pool.

D. Clark Co. Pool. G. Plymouth Pool.
 E. Sandoval Pool.
 F. Carlyle Pool.

be able to furnish necessary assistance and advice to operators in solving their oil-field problems.

RESULTS OF CORRECTIVE WORK

The corrective work discussed in this bulletin and summarized in Table 8, is entirely a commercial enterprise, and its practical value therefore depends upon the calculable profits resulting from it.

The total increase in "settled" production for the ten wells upon which repair work was done amounted to 66.5 barrels a day, at a repair cost of \$3,975. In other words this "settled" production was obtained at a cost of \$59.77 per barrel. The average increase of oil production per well was six barrels a day at the end of six months, and the average water decrease was 100 barrels a day. The average cost of repairs was \$361 per well. Not taking into consideration the saving shown by the decreased water production, but only the additional profit represented by the six-barrel increase, the cost of repair work was repaid in less than a month's time.

It will be noted that repair work on one well only (Ohio No. 5) resulted in a loss of oil. Even here, however, the decrease of water is so enormous as to partially compensate for the loss in oil, and all or part of this loss may perhaps be regained by cleaning out the cement and using a smaller quantity for the next attempt. From Ohio No. 10 there was no increase in oil, although the water was cut down considerably. From these two wells only no production gains were made. All other wells showed increased amounts of oil and decreased amounts of water lifted. From each of six wells the oil production was increased on the average more than six barrels a day. Two of them increased in production ten barrels or more per day, and one increased twenty barrels. From five wells were eliminated more than 100 barrels of water a day, and from one over 300 barrels were shut off by the use of cement.

PERMANENCY OF RESULTS

DECLINE CURVES

The immediate question concerning cementation and other similar repairs is as to their effective length of life. In reference to the probable length of life of the increase, frequent gages were taken on corrected wells. Two of the resultant curves on different types of repair work are shown in figure 19.

In an effort to control lower water, well No. 8 (fig. 19, A) was cemented with some difficulty in the early part of July. The work was not entirely satisfactory, but production was increased so that it was deemed unwise to try to correct it at the time. When the repair work was completed the production was oil, 65 barrels and water, 125 barrels, which amounted to an increase of 550 per cent of oil and a decrease of

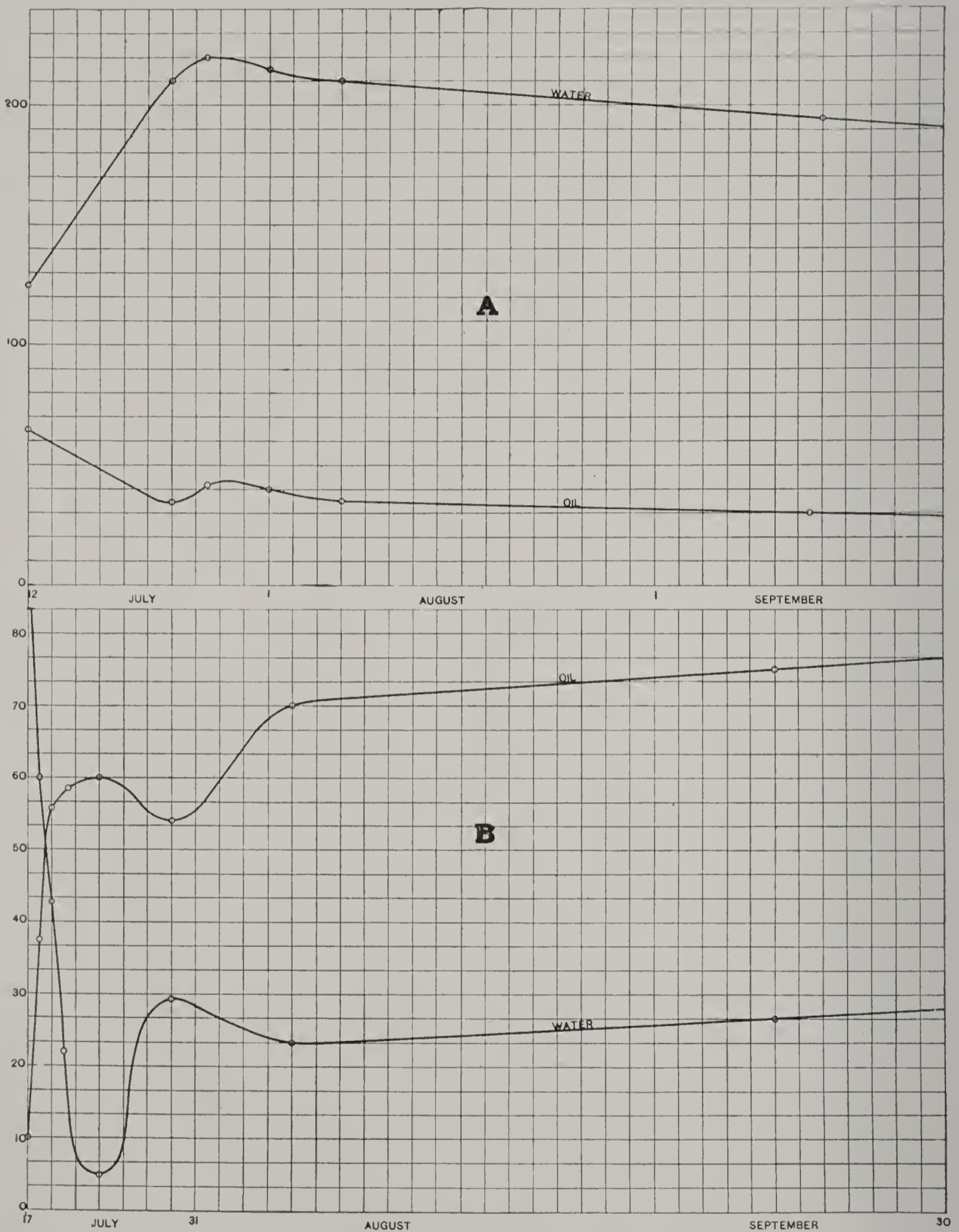

Fig. 19. A. Diagram showing the production of oil and water for Ewing well No. 8, Selby-Cisler Producing Company, beginning immediately after cementing. The production before cementing was: Oil, 10 barrels and water, 220 barrels.

B. Diagram showing the production of oil and water for Ewing well No. 5, beginning immediately after the packer was set. The production before packing was: Oil, 1.6 barrels and water 70.0 barrels.

TABLE 8.—Results of corrective work

Company	Well No.	Work recommended	Work done	Oil production gages				Increase per day	Cost	Water production			Remarks
				Before	Later	Work complete	2 mo. later			6 mo. later	Before	After	
Ohio Oil.....	4	Cement	Cement	Bbls. 6.1	Bbls.	Bbls. 35.	Bbls. 15.	Bbls. 8.9	Bbls. \$250	Bbls. 459	Bbls. 360.	Bbls. 99.	Not enough cement
Ohio Oil.....	5	Recase Cement	Recase Cement	5.3	5.	1.5	-3.5	250	350	2.5	347.5	Too much cement
Selby and Cisler..	8	Cement Recase	Cement Recase	10.	65.	a30.	20.	800	229	215.	14.	Cement giving way
Selby and Cisler..	31	Recase Cement	Packer Test Cement	2.9	30.±	b13.2	10.3	300	187	86.	101.	Probably better production than gaged
								35.7	\$1,600			561.5	
Ohio Oil.....	10	Recase	Recase	0.	0.	0.	0.	0.	\$800	47	?	?	
Selby and Cisler..	1	Recase	Recase	0.	5.	3.5	3.5	725	147	6.4	140.6	
Selby and Cisler..	7	Recase	Recase	1.5	3.	1.5	725	170	95.4	74.6	
								5.	\$2,250			215.2	
Selby and Cisler..	5	Recase	Packer	1.6	1.	1.8	.2	\$25	70	.5	69.5	
Central Refining..	15	Recase	Packer	.9	...	10.	10.4	9.5	25	103	10.7	102.3	
Central Refining..	17	Recase Cement	Packer	12.2	2.2	(3 mos. later.) 19.	9.8	50	242	172.	70.	Needs cement; would probably increase production.
Central Refining..	9	Recase and perhaps cement	Packer	3.7	6.3	25	152	126.	26.0	
								25.8	\$125			267.8	
								66.5	\$3,975			1044.5	

^a 3 months later

^b 1 month later

43 per cent of water. Twelve days later the oil had dropped to 35 barrels and water increased to 210 barrels. Both oil and water then declined slowly during the ensuing two months. The final gage showed 30 barrels of oil and 184 barrels of water.

In figure 19 *B*, is shown a decline curve for a well on which the problem was one of upper water elimination. In contrast with the cement curve, the water decreases sharply and then rises slowly. The oil rises rapidly at first as the water is eliminated, and then more slowly. It will reach its maximum and then start on the natural decline curve of the pool.

After the first acute adjustment is made the changes are quite gradual, in both the upper water and lower water problems, and if the work is done carefully the beneficial effects should last some length of time.

ACKNOWLEDGMENTS

The work was started by Mr. Merle L. Nebel and had been carried almost to completion at the time of his death in October, 1918.

Acknowledgments are due the Ohio Oil Company, the Central Refining Company, the Selby and Cisler Refining Company, James Pease and Company, and the Indian Refining Company for their hearty cooperation in supplying necessary data, their assistance in the preliminary field study, and their response to recommendations for corrective work.

Special acknowledgments are made to the Ohio Oil Company for necessary material used in the work, to the Illinois Pipe Line Company for the special equipment they supplied, and to the oil men of the district for their interest.

Acknowledgments are also due the Illinois State Water Survey for helpful cooperation and for numerous analyses. Mr. Frank J. Madden assisted in the gaging of wells and other work in the field.

Great aid was given by the numerous farm and lease foremen, employees, and officers of the companies, especially Mr. J. K. Kerr, Mr. C. W. Baker and Mr. Walter Lowrie, Mr. John Bell, Mr. R. S. Blatchley, Mr. Carl Morrison, Mr. Lawrence Myers, Mr. W. J. Hurd, and Mr. Charles Karnes. The work was a cooperative one, and grateful acknowledgment of the assistance they rendered is made.

STATEMENT OF PROBLEM

One of the most widespread and troublesome problems affecting production throughout the State is the great amount of water being

pumped to the surface along with the oil in the process of recovery. The water is separated from the oil by gravity. The methods of pumping and preparing oil for the market have been covered by Blatchley.¹ It is usually necessary to steam the oil before the water will settle out sufficiently to render the product acceptable to the pipe-line companies.



Fig. 20. Photograph of a casing corroded by water in the Flat Rock Pool.

Pumping large amounts of water with the oil is subject to the following economical disadvantages:

1. Power is wasted in lifting the water to the surface.

While it can not be said that the power cost would vary in direct proportion to the amount of fluid handled, nevertheless if the water content were eliminated it is certain the cost of production would be materially decreased.

¹ Blatchley, Raymond S., The oil fields of Crawford and Lawrence counties: Ill. State Geol. Survey Bull. 22, p. 159, 1913.

2. Corrosion of casing (fig. 20), rods, and lease piping occasions considerable expense of replacing such equipment which could be avoided if the amount of water were reduced.

3. The production of a well is often greatly reduced by ingress of water.

The exclusion of water from oil and gas productive strata was therefore undertaken as the first step in retarding the decline of oil production. This phase of the subject is dealt with exclusively in the present report.

SELECTION OF FLAT ROCK POOL FOR EXPERIMENTAL WORK

Several reasons combined to determine the selection of the Flat Rock pool. It presents a comparatively well-defined area and can therefore be considered as a unit free from the more complicated factors that might have developed in considering a like area of one of the larger pools. Also much trouble has been occasioned in this pool by the infiltration of highly corrosive waters, both top and bottom, into the wells. In fact, the water troubles in this pool are found so pronounced that any demonstration work accomplished in it should be highly convincing as to its effectiveness. A portion of the Flat Rock pool embracing approximately 300 acres, in sec. 31, Honey Creek Township (T. 6 N., R. 11 W.), was selected for intensive study. As shown on the map, Plate XII, the properties involved were under lease to four companies, as follows:

Central Refining Company—12 producing wells.

James Pease Company—9 producing wells.

Ohio Oil Company—13 producing wells.

Selby and Cisler Producing Company—15 producing wells.

GEOLOGY¹

GENERAL STATEMENT

The Flat Rock oil pool lies adjacent to the town of Flat Rock, in the southeast part of Crawford County, ten miles southeast of Robinson, the county seat. From Flat Rock it extends towards the northeast for a distance of five and one-half miles, including the small production in new territory at the northeast end. The area comprises all, or parts, of sections 1, 6, 30, 31, and 36 in Honey Creek Township, and sections 20, 21, 22, 29, and 32 in Montgomery Township. The pool is very irregular in shape, fingering out in several places, especially in the northeast part

¹ By T. E. Savage.

of the area. Its greatest width does not exceed three-fourths of a mile, and in some places it is considerably less than that figure.

The pool is separated by barren territory from the Robinson and New Hebron pools in the north, from the Chapman and Parker pools on the southwest, and from the Birds pool on the south. The producing area lies on the east slope of the La Salle anticline, but its long axis extends in a direction nearly at right angles to the trend of the main La Salle arch. During 1918 there were about 200 active wells in this area, which had an average daily production of about $3\frac{1}{2}$ barrels. When the pool was first opened in 1910, productions of 100 barrels per day were not uncommon. Within one or two years after the wells were drilled, the production declined rapidly to near the present figures, and since that time the decrease has been very gradual.

GEOLOGIC SECTION

The rocks exposed in this area, or penetrated in deep drillings, consist of a mantle of unconsolidated materials composed of glacial till, loess, alluvium, and wind-blown sand belonging to the Quaternary series, overlying hard rock strata of Pennsylvanian age.

QUATERNARY SYSTEM

The glacial till in the Flat Rock area varies in thickness from a few inches to 20 or 30 feet, the average being about 18 feet. It is of Illinoian age; it is bluish when fresh, but weathers to a yellow or brown. As elsewhere, this till is somewhat sandy, consisting of unsorted clay, sand, pebbles, and boulders.

The loess is a fine-grained, wind-blown silt which forms a sheeted deposit over almost the entire region, being thickest in the valleys, and thinner over the slopes and uplands. The alluvium consists of water-laid sand and clay, or mixtures of these, which in the larger stream valleys of the region have a thickness of 50 to 100 feet.

PENNSYLVANIAN SYSTEM

Below the unconsolidated surface material the drill has penetrated Pennsylvanian strata to a depth of 900 or more feet, without reaching the base of the system. These consist largely of shale and sandstones, or more commonly of mixtures of these, with thin beds of limestone and coal. They represent the McLansboro, Carbondale, and Pottsville formations, the latter containing the Robinson sand, which furnishes the oil and gas in the Flat Rock pool.

A generalized section of the Pennsylvanian rocks in this area is given below:

Table of Pennsylvanian rocks in the Flat Rock Pool

McLeansboro formation	Includes all of the Pennsylvanian rocks above the Herrin (No. 6) coal; consisting of shales and sandstones and thin beds of limestone and coal. Thickness 450 to 500 feet.
Carbondale formation	Includes the strata between the top of the Herrin (No. 6) coal and the bottom of the Murphysboro (No. 2) coal; comprising shales, sandstones, thin limestones, and important coal beds. Thickness 300 to 400 feet.
Pottsville formation	Includes all of the Pennsylvanian rocks below the Murphysboro (No. 2) coal; consisting dominantly of sandstones, with gray and black shales, and a few thin coals. Thickness in adjacent areas 500 feet, not entirely penetrated in the Flat Rock pool.

The following detailed log of the Selby and Cisler well No. 6, on the W. E. Ewing farm, near the center of the Flat Rock pool, will show more definitely the character and succession of the strata penetrated by the wells in the Flat Rock pool. This log was compiled from a study of the samples of drillings and from the driller's log, and is a representative record of the wells in this area.

Log of Well No. 6 on Ewing Farm, section 31, Honey Creek Township

	Thickness	Depth
	<i>Feet</i>	<i>Feet</i>
Pleistocene and Recent		
1. Till and loess, yellowish brown with small pebbles	23	23
2. Clay, hard	2	25
3. Clay and sand, yellowish gray, calcareous; fresh water	8	33
4. Clay, yellow bluish brown, and gray, calcareous, with small pebbles.....	5	38
Pennsylvanian		
McLeansboro formation		
5. Sandstone, gray, hard, shaly, calcareous.....	7	45
6. Shale, dark blue and gray, sandy, calcareous.....	20	65
7. Shale, black, hard, calcareous.....	2	67
8. Shale, black	35	102
9. Coal; some gas on top.....	6	108
10. Sandstone, white to gray, fine grained, shaly.....	4	112
11. Limestone, gray	33	145
12. Limestone, black	7	152
13. Limestone, blue and gray, granular.....	5	157
14. Shale, gray, sandy, calcareous.....	30	187
15. Shale, gray and dark.....	23	210
16. Shale, gray, calcareous.....	25	235
17. Shale, brown	15	250

Log of well No. 6 on Ewing farm—Concluded

	Thickness	Depth
	<i>Feet</i>	<i>Feet</i>
18. Sandstone, gray, fine grained, with some shale (some water)	60	310
19. Limestone, gray, and shale with some sand.....	10	320
20. Shale, blue	10	330
21. Sandstone, gray, fine grained, with salt water....	40	370
22. Shale, gray, hard.....	20	390
23. Shale, gray to dark brown, sandy.....	20	410
24. Shale, light gray.....	10	420
25. Shale, gray to brown.....	5	425
26. Limestone, light gray, shaly and sandy.....	5	430
27. Sandstone, fine grained, calcareous.....	10	440
28. Sandstone, dark, with some shale and limestone..	45	485
29. Shale, gray to dark, with some sand and limestone	3	488
Carbondale formation		
30. Coal (Herrin, No. 6 ?).....	5	493
31. Shale, sandy, gray, fine grained.....	32	525
32. Limestone, gray, with some shale.....	15	540
33. Shale, dark gray, hard.....	35	575
34. Shale, gray and dark, soft.....	10	585
35. Shale, gray and dark, hard.....	30	615
36. Sandstone, yellowish, fine grained, calcareous (600-foot "gas sand").....	20	635
37. Sandstone, gray to white, fine grained, water bearing	10	645
38. Shale, gray	30	675
39. Shale, black	20	695
40. Shale, gray, with sandstone, fine grained.....	15	710
41. Coal	Little	
42. Shale, light gray.....	40	750
43. Shale, gray to dark grayish brown.....	35	785
44. Shale, dark gray to brown, hard.....	1	786
45. Shale, blue gray, calcareous, with some fine sand..	12	798
46. Shale, gray and dark, with coal.....	2	800
Pottsville formation		
47. Shale, blue, with gray, fine-grained sand.....	70	870
48. Sandstone, dark gray to blue, shaly, calcareous, fine grained	23	893
49. Top of oil sand.....	..	905½
50. Bottom of upper streak.....	..	909½
51. Sandstone, gray, fine grained.....	1½	911
52. Sandstone, yellowish gray, fine grained (oil pay)..	8	919
53. Sandstone, gray, fine grained (water sand).....	5	924
54. Shale, blue	1	925
55. Sandstone, gray fine grained, with a few larger grains (water sand).....	10	935

POTTSVILLE FORMATION

The Pottsville, which is the lowest formation of the Pennsylvanian system, has not been entirely penetrated by the deep wells in the Flat Rock pool. From the logs of wells in adjacent territory to the west and south, this formation is known to have a total thickness of 550 to 575 feet. The rocks consist chiefly of rather massive sandstones, which merge into sandy shales in the upper part. A few thin coals are present at different levels.

The stray gas sands that are found in this area are thought to occur in the upper part of the Pottsville formation. The Robinson sand, which furnishes the oil in the Flat Rock pool, lies about 100 feet below the top of the Pottsville. Below the Robinson sand the sandstones in the lower part of the formation are usually filled with water.

CARBONDALE FORMATION

The rocks of the Carbondale formation, like those of the overlying McLeansboro, are dominantly sandy shales, but they also include beds of micaceous sandstone, thin limestone, and important coal beds. The most prominent members of the formation are the Herrin (No. 6) coal at the top, the Harrisburg or Springfield (No. 5) coal 50 to 60 feet below the Herrin bed, and the Murphysboro (No. 2) coal at the base. The so-called "gas sand" occurs near the middle of the formation. The total thickness of the Carbondale strata in this area is about 350 feet.

MCLEANSBORO FORMATION

A thickness of 40 feet in the upper part of the McLeansboro formation is exposed in the vicinity of Flat Rock. These strata consist of 15 to 18 feet of yellowish-gray, rather thick-bedded, micaceous sandstone, often with a conglomerate 1 to 2 feet thick at the base, below which is a marked unconformity. In places this sandstone is underlain by bluish-gray shale which is in places obliquely jointed, and has a thickness of 12 to 14 feet. In other places in this vicinity the shale bed had been entirely cut out by erosion prior to the deposition of the conglomerate. Underlying the shale horizon is a gray, coarsely granular limestone, 2 to 5 feet thick, which is usually separated from an 18-inch coal bed by 1 to 3 feet of dark shale. Below this coal the deep wells usually penetrate gray and bluish or dark sandy shales interbedded with gray sandstones, shaly sandstones, and carbonaceous shale. In the lower part of the formation there occur with the shale and sandstone an occasional band of limestone and thin coal. The exposures of McLeansboro strata in this area show a number of low undulations, but in general they lie almost horizontal over the entire area. The total thickness of the formation in this region is 450 to 500 feet.



Map showing structure on the surface of the 600 foot "gas sand" in a portion of the Flat Rock pool

THE PRODUCING SANDS
THE 600-FOOT "GAS SAND"

Near the middle part of the Carbondale formation is a sand that usually contains more or less gas, and is known locally as the 600-foot "gas sand". It varies greatly in thickness from place to place, a range from almost nothing up to 50 feet having been reported in different wells. This sand has a characteristic yellowish-brown appearance and oily feel.

STRUCTURE OF THE SAND

A structure map of the Pennsylvanian rocks in this area, shown by contours drawn on the top of the "gas sand" (Plate X), appears to indicate that the places where the sand is highest are in the southwest part of the pool, from which the surface of the sand declines rapidly in a northeast direction toward the Hope and Tohill farms of the Ohio Oil Company leases. Consistent with this structure the gas supply is somewhat greater in the higher, southern parts of the pool than farther north in the area. The gas from this sand furnishes the greater part of the fuel used in pumping the oil in the entire Flat Rock pool.

When the first wells were put down in this pool, the pressure of the gas was excessive, and difficult to control. Wells were often permitted to blow for days, and in some cases for an indefinite time, before any effort was made to stop the flow of gas. Even when the wells were plugged in accordance with legal requirements, the waste of gas was not prevented, as the sand and steel balls were not sufficient to stop the flow.

UPPER SALT SAND

The "Upper salt sand", also known as the "600-foot salt sand", is a slightly consolidated, water-bearing sandstone, occurring immediately below the "gas sand" and present over the entire area of the Flat Rock pool. The sand grains are commonly clean and white, containing some brownish feldspar, but the material is in strong contrast with the brown "gas sand" that lies above it. The water that causes the corrosion of the pipes and casings in this field comes from the "upper salt sand". The thickness of this sand ranges from 20 or 30 to 60 or more feet, being greatest where the overlying "gas sand" is thin, and thin where the latter sand is thicker. The drillers usually report no break or parting between the "gas sand" and the "upper salt sand". However, by careful watching during the drilling of this part of the section in the Ewing 6B well, a thickness of 3 to 6 inches of hard shell parting was noted immediately above the water sand. It is possible that such a thin parting separates these sands in other parts of the Flat Rock pool. This im-

pervious parting between the sand horizons doubtless would account for the fact that water from the wells that do not reach the bottom of the shallow "gas sand" is seldom actively corrosive, while the water from the oil wells that penetrate the underlying "upper salt sand" causes a great deal of trouble by its corrosive action in the casing. This highly mineralized water from the "upper salt sand" attacks the well casings so rapidly that near the middle of the pool, where the trouble is greatest, the life of the casings may not be longer than 18 months to 2 years. It has destroyed an immense amount of casing and will ultimately cause the abandonment of the field before the complete drainage of the oil pool unless preventive steps are taken.

FLAT ROCK SAND

Practically all of the oil production in the Flat Rock pool comes from what is known in this area as the Flat Rock sand, the equivalent of the Robinson sand farther north and west. In this pool the sand is yellowish-gray and rather fine grained, and lies about 900 to 1,000 feet below the surface, the differences in depth being largely due to the relatively rapid thinning and thickening of this bed. The larger part of the oil comes from a depth of 925 to 950 feet. This sand appears not to be continuous over the entire Crawford County oil field, but occurs as disconnected lenses of different sizes, shapes, and thicknesses irregularly spread over the region at a fairly well-defined horizon. It is most conspicuously irregular in the northeast and the southwest portions of the Flat Rock pool. In the Montgomery Township area the sand occurs in three lenses each of which contains oil, but only the lowest furnishes paying production.

The upper surface of the sand seems to present a succession of ridges and depressions which in general extend parallel with the long axis of the pool. The ridges and several of the depressions are shown on the structure map, Plate XI. It is significant that the strongest well in the Flat Rock pool is located on one of these ridges. This is the Selby and Cisler well No. 8 on the Ewing farm.

The pay portion of the Flat Rock sand is usually immediately underlain by water and is commonly only 3 or 4 feet thick. However, the logs of some of the wells, notably those on the central Tohill farm, indicate a thickness of 70 feet for this sand. In some of the wells located over depressions in the sand, the drill passed into the water sand without encountering any oil pay.

The salt water that is present immediately beneath the oil pay, from which it is not separated by a parting of any kind, was evidently instrumental in the collection of the oil, and it rises higher into the

oil sand as the oil is exhausted from above it. When the pool was first drilled, the head was so strong in some of the wells that the water rose and flowed out over the top.

In drilling wells at present the greatest care is necessary not to penetrate so near to the water sand that the shot of nitroglycerine will break into this sand and flood the well with more water than the pumps can handle. In such an event the only remedy is the use of cement to close up the pores and cracks in the water sand, and so shut off the flow of water, a solution only slightly less corrosive than that from the "upper salt sand". This method of control of the lower water is eminently successful in all cases where it has been used with proper precautions in the process of cementation.

STRUCTURE

It may be seen from the structure map on which the contours are drawn on the Flat Rock sand (Plate XI) that this sand appears to be lenticular, the lenses extending in long narrow belts having a general northeast-southwest trend. The slope on the southeast side of the ridges is rather regular and gradual, while on the northwest side the sand fingers out in irregular, lobate extensions. The depression contours on the west side also appear markedly different from those in the east side.

Mr. Rich¹ has suggested that in the Flat Rock pool the oil-bearing sands may be a part of a great delta formation in which are combined river-channel deposits, shore or barrier beaches, thrown up by waves in front of a delta, and wave-worked sand spread out upon the adjacent ocean bottom. By this explanation the Flat Rock sand would appear to represent off-shore or barrier beaches built up by the waves along a delta front. The trend of the axes of the minor ridges and depressions, parallel with the long axis of the pool, is consistent with this explanation. The gradual slope on the east and the minor depressions on the west are also in harmony with such an explanation. The more or less irregular character of the contours on the west, while those on the east are confined to larger curves, can also be explained on the assumption of an irregular lens of sand. In the Flat Rock pool as a whole the top of the Robinson sand lies from 30 to 50 feet higher than the level of this sand in adjacent areas, a feature which was due in part at least to deformation. The character of the surface with its parallel ridges and its fingering lenses is such as to indicate that these local irregularities of the sand are due to its mode of deposition, rather than to deformation after the material was deposited.

¹Rich, John L., Oil and gas in the Birds quadrangle, Ill. State Geol. Survey Bull. 33, p. 137, 1916.

OIL CHARACTERISTICS.

The oil from the Flat Rock pool has rather high specific gravity and sulphur content, although the variation is considerable even in the small area under consideration. One well, No. 12 on the L. N. Tohill farm, sec. 31, Honey Creek Township, shows a gravity as low as 30.5° Beaumé, while well No. 27 on the W. E. Ewing, section 31, E. Honey Creek Township, has a gravity as high as 18.4°. A few scattered samplings determined the fact that there was considerable variation, and the work was continued to bring to light any regularity, if such did occur.

A sample was taken from every well and carefully warmed and the gravities taken. When these were plotted, so marked appeared the tendency for the lighter oils to find their way to the center of the pool that a contour map was based on the gravities alone (fig. 21). This map showed that the lighter oils were restricted almost entirely to the center of the pool, though the heavier oils would occasionally be found there also.

There are two possible explanations for the occurrence¹: First, the lighter oils may have migrated bodily to the upper portions of the pool. This is unlikely since petroleum is a solution of different constituents mutually dissolved, and solutions will not separate gravitatively. Second, through change of temperature or pressure, the gaseous hydrocarbons may have been released from the oil and migrated as gas along the top of the sand and reabsorbed. The action would not be uniform and would be incomplete, but the tendency would be to move the gases toward the higher portion of the pool. If this is the case, the difference is due only to the presence of more dissolved gases in the center of the pool than upon its flanks. This is supported by the fact that the wells that produce "lively" oil are mostly found in the central portion.

The only certain test would be a chemical analysis to see if the difference was a major one, involving the constituents of the heavier oils, or a minor one affecting only the gaseous part of the series.

WATER CHARACTERISTICS

The corrosive waters of the Flat Rock pool are of two varieties, the upper water is the more active of the two, and it differs essentially from that of the lower sand.

Analyses were made of the waters, both in the laboratory and field by the Illinois Water Survey, as shown in Table 9. The upper water is high in chlorides, sodium, potassium, calcium, and magnesium. The lower water is high in sulphates and lower in the alkali and alkaline

¹ Rich, J. L., Oil and gas in Birds quadrangle: Ill. State Geol. Survey Bu 1, 33, p. 139, 1916.

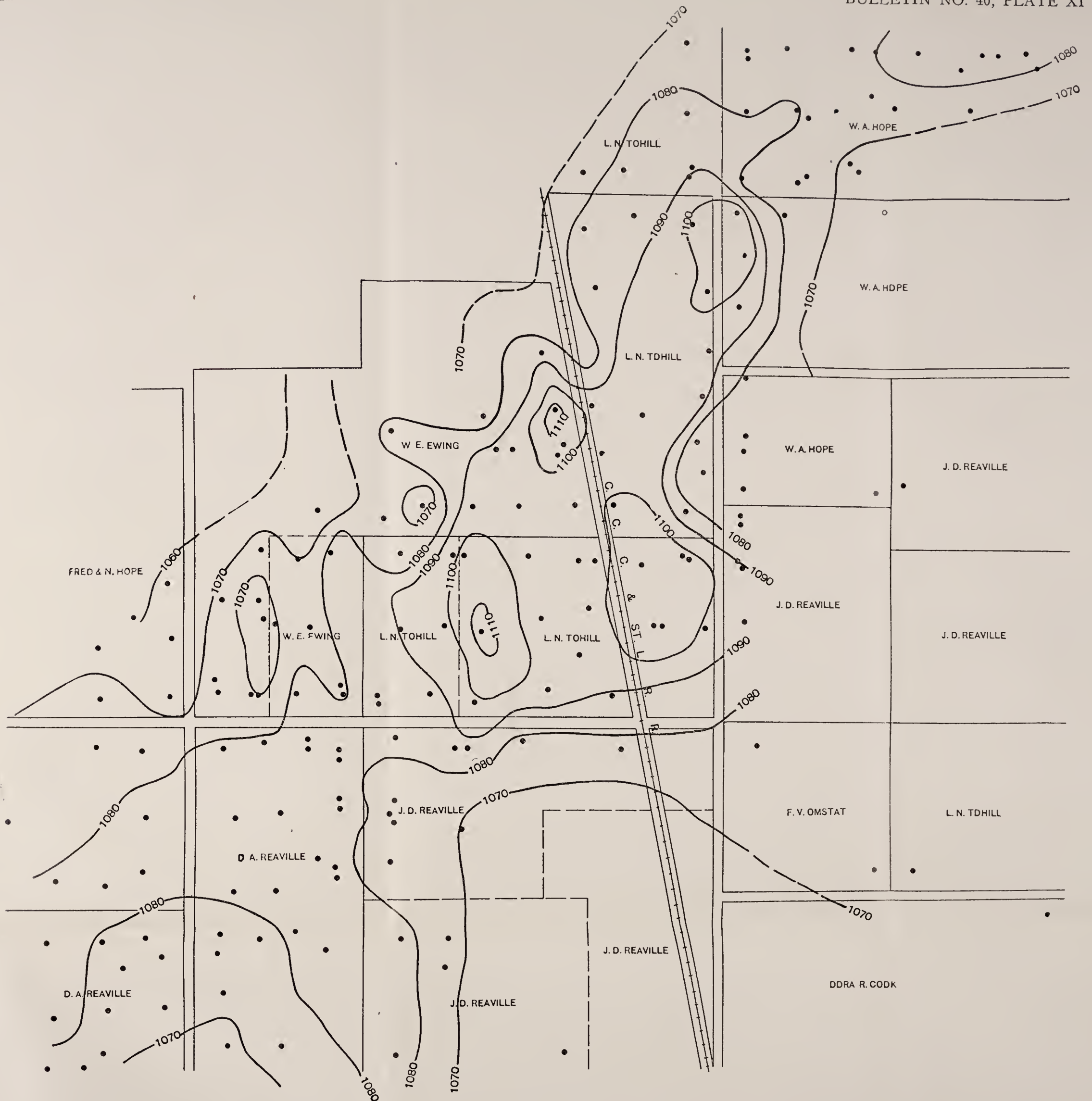

Map showing the structure on the surface of the Flat Rock sand in a portion of the Flat Rock pool

ILLINOIS STATE GEOLOGICAL SURVEY



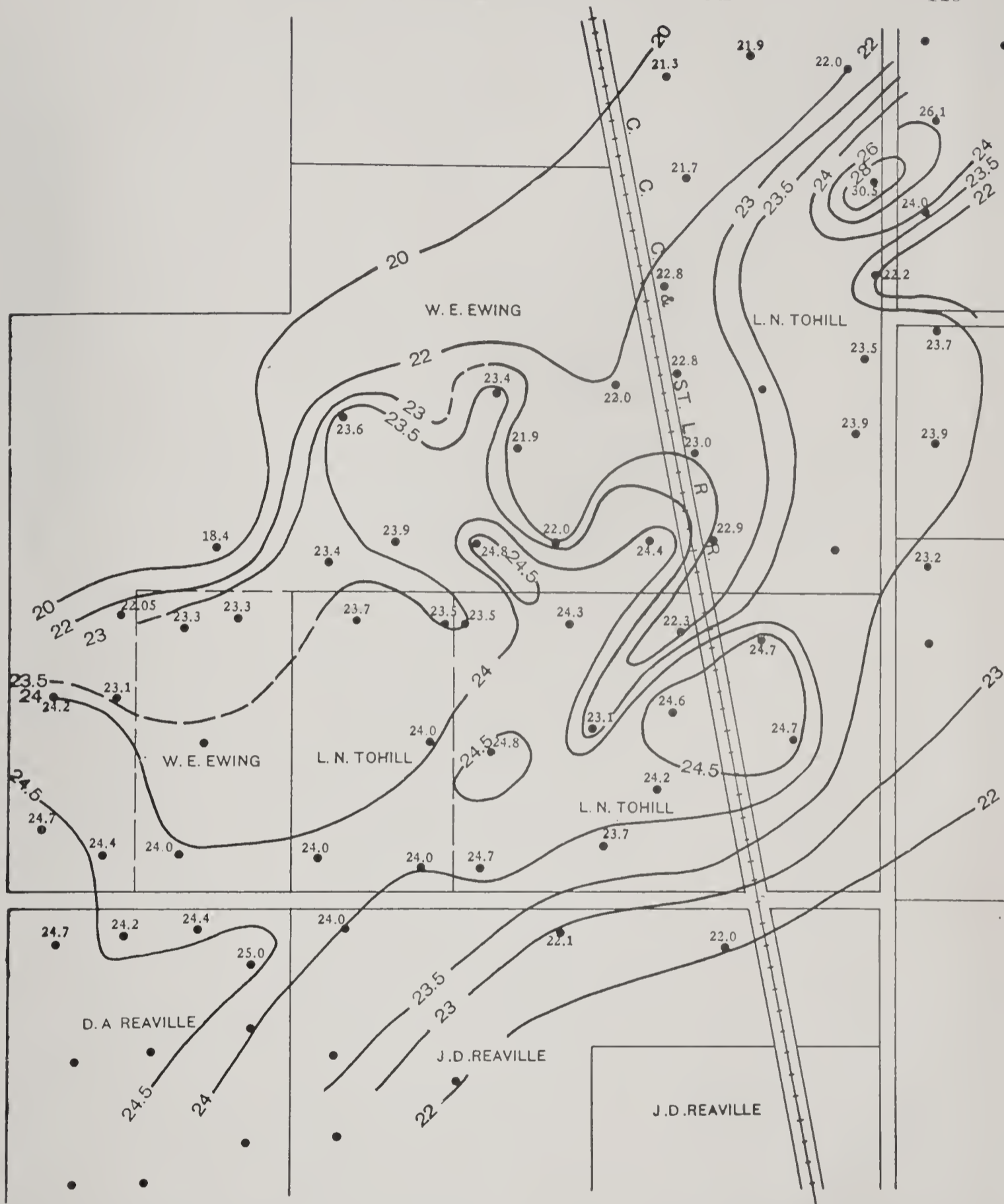

Fig. 21. Map showing contours on Beaumé oil gravities. The lighter oils are in the higher parts of the structure. (Compare Plates X and XI.)

earth chlorides. The total of dissolved salts in the upper water is almost twice that in the lower. The hydrogen sulphide content is similar.

The chemical reaction is somewhat complicated¹, and research work has not as yet been completed. The iron is dissolved in a somewhat complex reaction and precipitated as a sulphide. It is carried in suspension to the water-receiving tanks and there deposited.

¹ Unpublished report on corrosive reactions by W. F. Monfort of Ill. Water Survey.

TABLE 9.—Analysis of Waters from Oil Wells in the Flat Rock Pool^a
(parts per million)

	40078 8-30-18 O. O. Co., No. 10	40079 8-30-18 C. R. Co., No. 15	40080 8-31-18 S. C. P. Co., No. 5	40081 8-31-18 S. C. P. Co., No. 31	40082 8-30-18 C. R. Co., Gas No. 1	40084 8-30-18 C. R. Co., No. 16
Source.....	Top	Bottom	Bottom	Bottom	Top	Bottom
Laboratory number.....	40078	40079	40080	40081	40082	40084
Date.....	8-30-18	8-30-18	8-31-18	8-31-18	8-30-18	8-30-18
Location.....	O. O. Co., No. 10	C. R. Co., No. 15	S. C. P. Co., No. 5	S. C. P. Co., No. 31	C. R. Co., Gas No. 1	C. R. Co., No. 16
Water						
— ratio (bbls. a day).....	10.7 — 10.4	41 — 43	187 — 2.9	Gas	88 — 7.8
Oil						
Appearance (turbidity).....	Black	Black	Brown	Black oil	Red-brown	Black
Suspended matter, total.....	144.	65.	236.	516.	72.
Alumina.....	21.5	25.6	8.8	14.7	b93.	10.6
Iron oxide.....	38.5	61.4	54.2	14.3	26.4
Sulphur.....	15.9	29.1	3.	15.7	0.	15.8
Dissolved gases						
Hydrogen sulphide H ₂ S.....	0.	0.	2.6	19.4	4.5	0.
Carbon dioxide CO ₂	5.	5.	5.	4.	5.
Colloidal matter						
Silica SiO ₂	20.	14.	13.	19.	1.	20.
Alumina Al ₂ O ₃	b4.	3.8	4.8	b9.	b4.	b8.
Dissolved radicles						
Iron Fe.....	1.4	2.
Calcium Ca.....	217.1	153.6	191.9	277.3	270.8	156.
Magnesium Mg.....	190.	170.8	202.5	218.4	222.8	221.5
Ammonium NH ₄	9.	6.2	10.3	5.1	5.1	5.2

Sodium and Potassium Na and K....	11410.	5184.	5633.	4787.	13380.	4910.
Bicarbonate HCO ₃	567.	660.	807.	490.	488.	493.
Sulphate SO ₄	270.4	1933.	1712.	2010.	0.	2055.
Nitrate NO ₃	14.2	1.3	1.1	1.4	1.4	0.7
Chlorine Cl.....	18005.	6892.	7995.	6140.	21430.	6741.
Phosphate PO ₄	Trace	Trace	Trace	Trace	Trace	Trace
Dissolved solids 180°.....	30896.	11816.	16318.	14346.	35704.	14545.
Error of analysis.....	10.06 %	+0.27 %	-0.55 %	+0.55 %	-0.29 %	% 88.0—
Total iron Fe.....	26.	45.	37.	8.	44.	14.5
Probable ferrous sulphide (FeS) in suspended solids.....	43.1	87.6	8.2	12.6	0.	22.8
Hydrogen sulphide as uncorrected.....	7.9	24.6	5.8	24.3	4.5	7.3
Alkalinity uncorrected.....	488.	632.	666.	450.	400.	430.

^a O. O. Co.=Ohio Oil Company.

S. C. P. Co.=Selby and Cisler Producing Company.

C. R. Co.=Central Refining Company.

Alkalinity is corrected for suspended sulphides.

Hydrogen sulphide is corrected for suspended sulphides which are titrated.

^b Fe₂O₃ and Al₂O₃.

INVESTIGATION PRIOR TO RECOMMENDATION

The work done in the pool depended largely upon the well logs and well histories that were obtained in the preliminary investigation of the pool. In gathering well statistics the past history of the well and its present condition were considered of the utmost importance for upon these things the recommendations depended. Almost without exception skeleton logs only were obtainable, showing the top and thicknesses of the oil pays and occasionally the locations of the upper water and gas sands. Mistakes were found, and allowances had to be made for errors and non-uniformity of methods of measuring, since some drillers measure to the top of the sand whether dry or not, while others measure to the top of the oil-producing horizon only.

The majority of the records were collected in 1913¹ and required only occasional checking. The logs of the more recently drilled wells and some that had been previously overlooked were collected from the producing companies and drillers.

In addition to the actual logs, the knowledge of the field superintendents, foremen, and pumpers, concerning history and present condition of the well, was incorporated in the well log. This included the condition of casing, age, and if possible the weight, in addition to information as to casing replacements, inside strings, and tubing packers. If packers had been set, either on tubing or on a second water string, their kind, size, and depth of seat were of importance. This information was found invaluable when the recommendations for corrective work were made.

The elevations of the wells were run with plane table and alidade from primary traverse between United States Geological Survey bench marks. The elevations were taken to the nearest foot only. The elevations of the sands were then reduced to a datum plane 1,000 feet below sea level. It was from these figures that the structure maps on the oil and gas sands and the peg-model sections and graphic logs were made.

PEG MODEL

Before actual work in the field was begun, a peg model of the pool was constructed. The model was made to scale, 150 feet to the inch both vertically and horizontally, to prevent exaggeration of the field structure. Upon this model all drill holes, gas or oil, dry, abandoned, or producing, were located. The logs of the wells were next painted on dowels which were then set into the base map up to the level of the

¹Blatchley, R. S., The oil fields of Crawford and Lawrence counties: Ill. State Geol. Survey Bull. 22, 1913.

datum plane. This left the tops of the log sticks conforming to the topography of the area.

The model was finally completed by connecting the different sands with mats of colored strings. Two upper water sands, a gas sand, an oil sand with from one to three pays, and a lower water sand, were

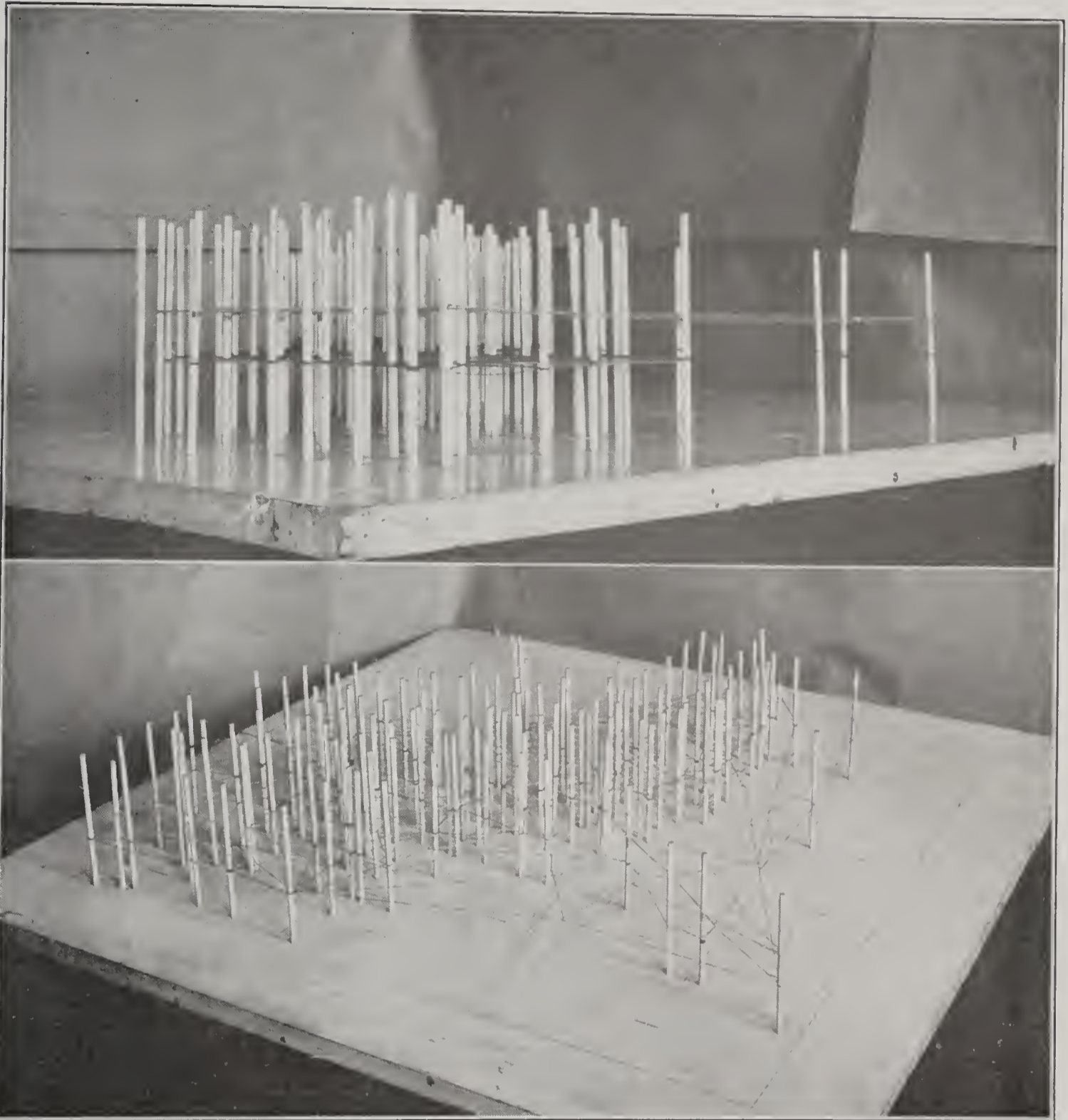

Fig. 22. Photograph of the peg model, use in the field to represent sub-surface conditions

shown up at fairly constant levels (fig. 22). The area was marked by a structure convex upward, sloping gently away from the producing pool, both in the oil and upper water sand, although the data for the latter were lacking at the most interesting points.

OIL INVESTIGATIONS

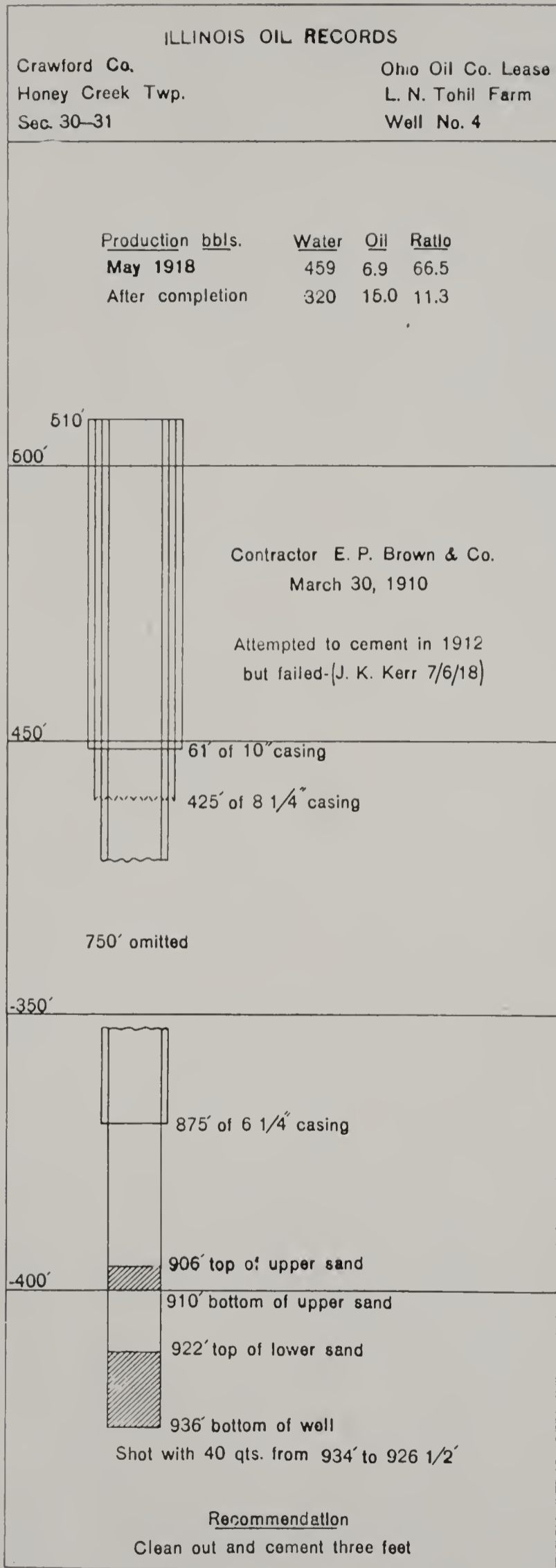

Fig. 23. A graphic log typical of those used in studying wells with sub-normal production.

The model was built to give an exact picture of the actual subsurface conditions of the pool, to show any discrepancies of casing of wells, or of total depth. In addition, it served as a means of explaining to practical oil men what the sand would actually look like if they could see it.

GRAPHIC LOGS

After all obtainable data on the wells of the pool had been collected, and after the preliminary gaging had been completed, all wells with subnormal production were graphically logged, as this was the most efficient way of grouping all different characteristics and possibilities. They showed (fig. 23) the elevation of the top of the well, the depth at which each string was set, the presence or absence of outer strings, and the date they were pulled, if ever. They showed the depth, thickness, and relative productivity of each pay sand, and the amount of break between them, the gaged production in both oil and water, and the date of gaging. They also showed where possible the names of the contractors and of the drillers who had actually done the work on the wells, and in addition the kind of remedial work done, such as cementing or casing repairs.

With the material assembled in this manner, the recommendations for corrective work were more easily understood, and the reasons for them more clear.

PRELIMINARY GAGING

The whole work in the pool depended upon the accurate gaging of the oil and water production of each individual well. Since nothing exactly similar had been attempted in this line before, there was more or less evolution in the methods used during the procedure of the work.

The gaging outfits changed progressively throughout the whole work, as the need arose and the chances for improvement showed themselves. At first all the gaging was done in 50-gallon oil barrels or in small five-gallon kegs or cans (figs. 24 and 25). These were all strapped before they were used (gallons per inch of vertical distance computed and checked), so that inches or feet in the barrel could be computed in gallons of fluid. This was found sufficiently accurate for the water gages, but invariably the oil gages were too high, sometimes as much as 50 per cent.

The setup that produced the best results was a three-barrel arrangement patterned after the present water-separating system used in the district (figs. 26 and 27). A receiving barrel was used with two outlets, the lower one connected by a siphon pipe with the water barrel, and the other, nearer the top of the barrel connected with the oil barrel.

The former outlet is generally $1\frac{1}{2}$ or 2 inches in diameter, and the latter $1\frac{1}{2}$ inches. Both have stop-cocks to control the flow of fluid and so keep the line of demarcation between the oil and the water at a constant position near the middle of the barrel. The water barrel has a 2-inch outlet and stop in the extreme bottom. It is necessary to have the outlet of the water barrel of large size to prevent overflow of the separator system while the water barrel is draining. The outlet of the oil barrel is also placed in the lowest portion of the barrel to permit complete drainage of the oil from that barrel. This should also be $1\frac{1}{2}$ inches, as the oil runs rather slowly in cold weather, and in some cases the oil may fill the separator and flow out of the water siphon into the water barrel before the oil gage is completely emptied, if the outlet is small.

When the three-barrel siphon is put in use the fluid from the well is turned into the separator barrel and the time taken accurately. With both outlets closed, the fluid is allowed to fill the barrel and the time is taken. The water siphon outlet is then opened and the water barrel filled. The siphon is closed, the water outlet opened, and the water allowed to flow back into the lease receiving tank. The water outlet is closed, the siphon opened, and the water started running for the second barrel of water. When the oil becomes four or five inches deep on top of the salt water in the separator barrel, the upper oil outlet in that barrel is opened, and the oil allowed to run over into the oil barrel, always, however, keeping one or two inches of oil in the separator barrel and closing the oil outlet while the siphon is closed, or the water rising in the barrel will carry the oil level above the level of the oil outlet and allow water to be carried over with the oil into the oil barrel. When the oil barrel is completely filled, the lower cock should be opened a little, and any water which has been carried over with the oil should be drained off and the barrel refilled. In cold weather when the oil does not run freely, a steam coil in the oil barrel will give more accurate results. The steam should be kept exhausting slowly through a coil in the oil barrel. The oil as it passes over it will be warmed and the separated water can be drained off at the bottom of the barrel as before. Whenever an oil or water barrel is emptied, the notation should be made of it on the gage board.

This gaging outfit when once set up was extremely practicable and not at all hard to operate. The results were uniformly good, and the outfit, once set up on the top of the receiving tank and connected with the wells, required no attention beyond the use of a watch and the turning of the cocks.



Fig. 24. Photograph of a single-barrel gage setup used early in the work.

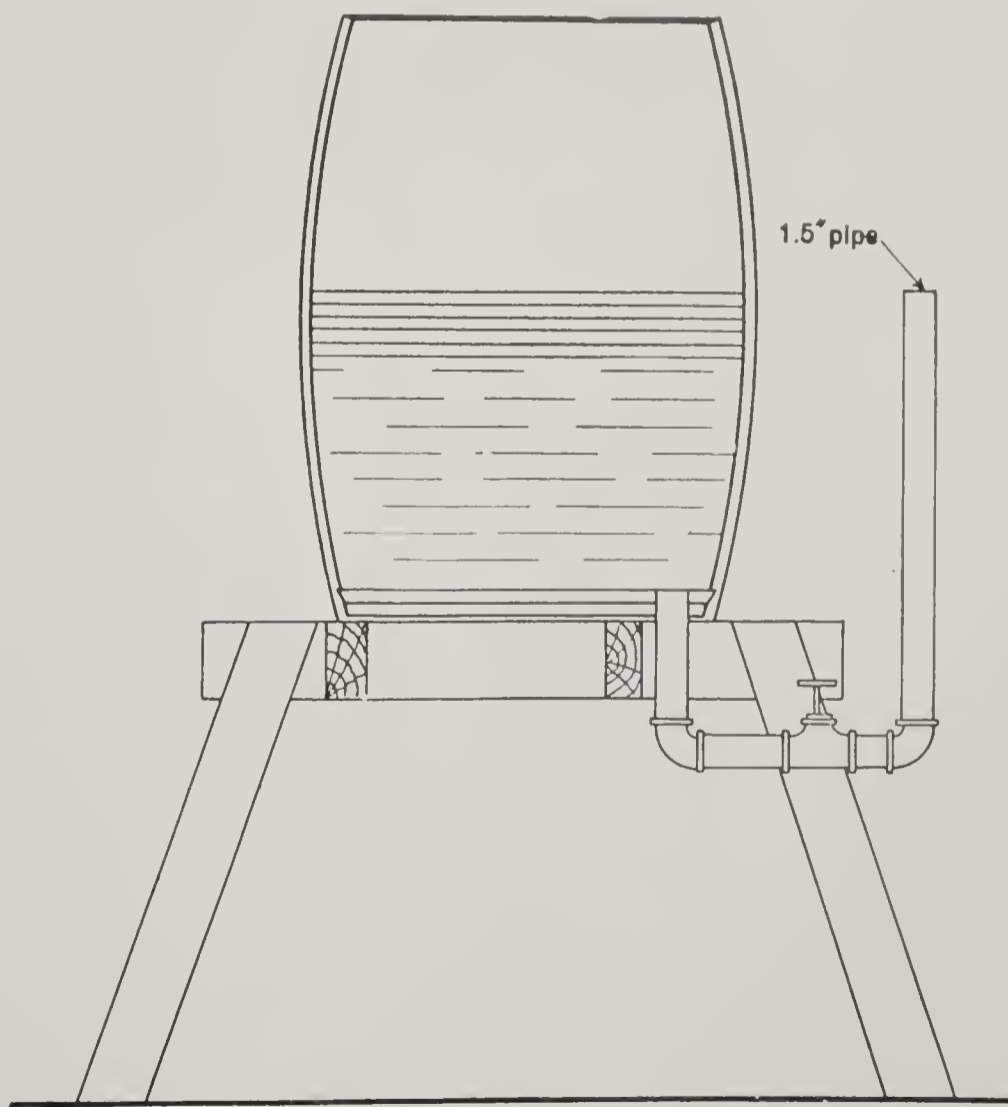

Fig. 25. Diagram showing in detail the plan of the single-barrel gage setup.

METHOD OF RECORDING DATA

All records of observations were made immediately after the gaging was completed. They showed in all cases, the time of day, the date, and the weather if it had any influence on the work. The character of the oil and the water pumped was also included, and if any oil was taken to run for gravities, it was given a sample number. The form used was in figure 28. The amount of both water and oil was entered in gallons, and the total amount per day computed in terms of 42-gallon pipe-line



Fig 26. Photograph of the three-barrel siphon gage setup in operation.

barrels. The calculations were in principle the same for each of the different methods of gaging used:

$$\frac{\text{min. in 24 hrs.}}{\text{min. length of gage}} \times \frac{\text{gals. oil or water}}{42}$$

After the gages taken in the field had been completed the average production was entered on the lease sheet (fig. 29). These showed well number, length of time pumped daily, production as gaged and as cut to fit the lease runs. Estimates made by the pumpers or lease foremen were also entered, leaving the rest of the sheet for pertinent remarks concerning the well. In some cases this showed at a glance that corrective work would be of prohibitive expense or else entirely useless, as is shown by wells Nos. 3 and 9 on the sheet (fig. 29), one with nothing but 4 $\frac{7}{8}$ -inch casing in the hole and the other with 40 feet of working barrel and anchor pipe in the bottom of it. The latter precludes a cementing

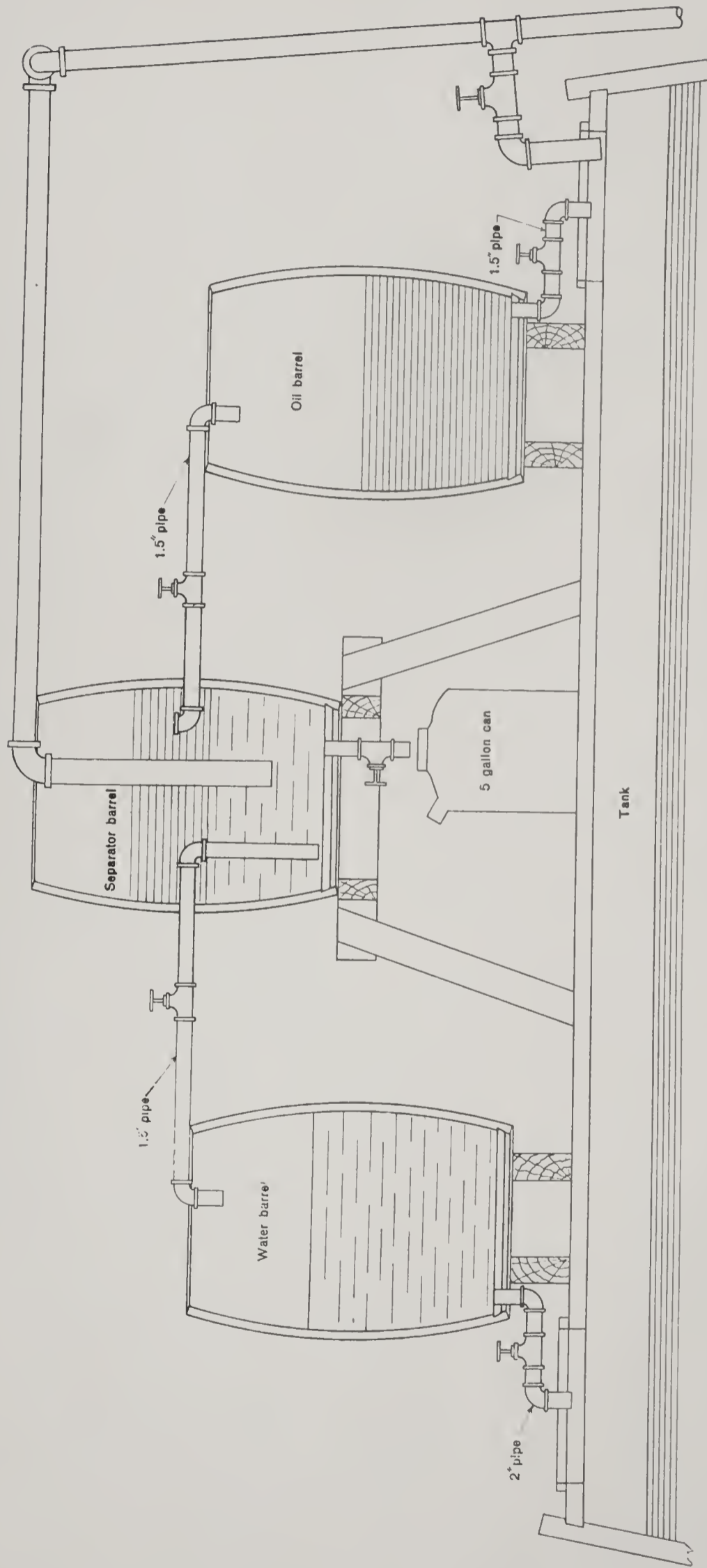

Fig. 27. Diagram showing in detail the plan of the three-barrel siphon gage setup. The apparatus is shown on the tank rather than beside it as in the photo graph (figure 26) of a similar setup.

GAUGE SHEET, CRAWFORD COUNTY, ILL.

Producer Selby-Cisler

Lease W. E. Ewing

Sec. 31, E

Twp. Honey Creek

Date	Time of Day	Well No.	Time of Runs			Water		Oil		Sample	Remarks
			Begin	End	Diff.	Gal. Test	Bbl. 24 Hr.	Test	24-Hr	For Sp. G	
11-4-19	A. M.	31	9:18:00	10:18:00	1: 0:00	151.0	86.0	23.0	13.2	1	Pumping poorly Recased
	P. M.	7	1:15:00	2:20:00	73:00	203.0	95.4	6.5	3.05	2	
11-5-19	A. M.	11	9: 8:00	10:38:00	1:30:00	176.0	67.	10.	3.8	Water black
	P. M.	16	1:11:00	12:26:00	1:15:00	270.	123.	20.	9.1	7	
12-31-19	A. M.	8	10:00:00	12:00:00	2:00:00	800.	228.	117.	33.4	5	More water than pump can handle
	P. M.	8	1:58:00	3:58:00	2:00:00	817.	233.	127.5	36.5	

Fig. 28. Sample record sheet as used in gaging.

LEASE SHEET, CRAWFORD COUNTY, ILL.

Producer, Central Refining Co.

Lease, L. N. Tohill.

Sec. 31 E.

Twp. Honey Creek

Well No.	Time pumped.	Production			Esti- mat'd	Ratio	Remarks.
		As gaged	Cut to runs		<u>Water</u> Oil	
1	4-2	27.0	7.9	..	4	3.4	Cemented 3½ feet
	118.	5.2	..	4	22.7	Nothing but 4¼ inch pipe
5-6	1½	.7	2.5	..	3	.3	Drilled only to top of sand. String in hole
7-5	125.	7.6	..	4	16.5	
8	8	19.	1.	..	2	19.	
9	152.	3.7	..	7	41.	*40 ft. working barrel and anchor in hole
9	126.	10.	12.6	Set packer; improved oil 150 per cent
10	1½	6	2.4	..	2	2.5	Cemented 11 ft. to 949
13	1	2.	*Drilled only to upper sand
13	Deepened; hit water; pulled and plugged
14	2-2	9.	1.	9.	
15	103.	.9	..	1	115.	*Leak in casing
15	4-2	10.7	10.4	1.3	Set packer at 774; increased oil 100 per cent; reduced water 90 per cent
16	8	83.	7.8	..	2	11.	
17	209.	12.2	..	8	17.1	*Cemented in 1916 3 feet; pumping capacity on 2½ inch tubing
17	242.	2.2	110.	Pipe gave way
17	204.	19.	10.7	Packer in bottom joint
17	208.	12.2	17.1	Would help to cement.

* Denotes recommendations. (See table 10)

No cut needed on gages.

Estimations by Lawrence Mvers.

Fig. 29. Sample lease sheet showing gage averages.

job, but not a casing job. Both of these wells, as shown by the ratio, need remedial work, but under the conditions the money spent would probably never bring a return.

Some difficulty was experienced in keeping the gage sheets clean in the course of work with oily fillings, gage cans, etc. To overcome this, the gage board with sliding cover shown in figure 30 was made and gave satisfaction.

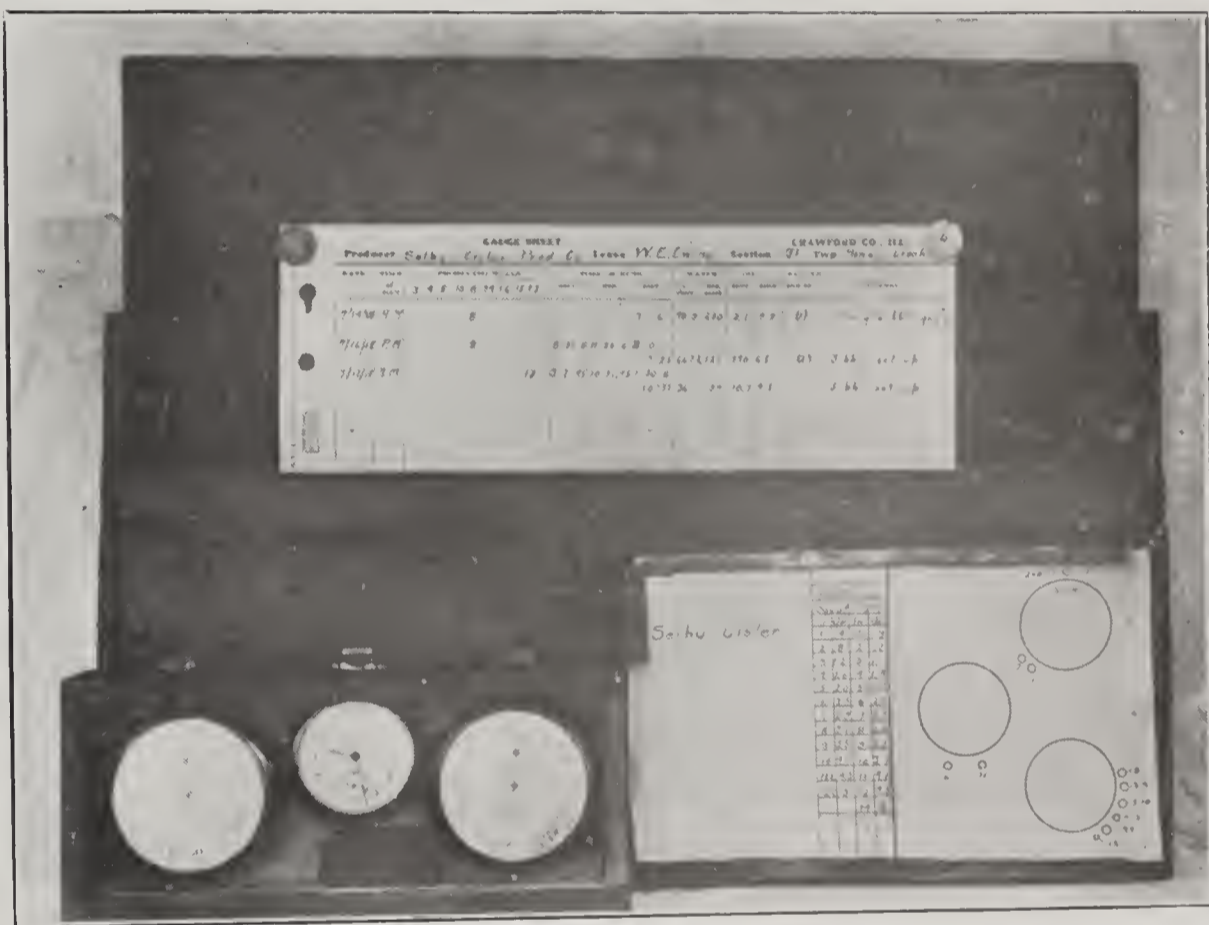

Fig. 30. Photograph of the gage board devised for protection of the records while in use on the lease.

After the gage-averages had been transferred to the lease-total sheets they were summed up, and the total number of barrels of oil a day checked against the pipe-line runs for the lease. On the later improved gages, these pipe-line runs checked closely with the sum of the individual well gages. On the earlier runs the totals ran high, due to inclusion of more or less water with the oil, as gaged in the barrels. A percentage correction was made on all the well productions as gaged, cutting them down so that the totals of the gaged production equaled or exceeded the lease runs by only a slight margin.

On some of the leases it was impossible to try to check the gages against the runs because at no time were they pumped steadily enough to keep the water off the sand. On others the wells were pumped irregularly, and a cut of gages to meet the runs would have taken them beneath their true possibilities.

RATIO

In the last column of the lease sheet was placed the ratio of the water to the oil, that is, the number of barrels of water divided by the number of barrels of oil pumped by that particular well. Thus, if a well pumps 100 barrels of water and 1 barrel of oil, the ratio would be 100, while if it pumped three barrels of oil, the ratio would be $33\frac{1}{3}$. From these figures was determined which wells were giving good results and which were not. The work was concentrated upon wells with ratios 30 or above. Doubtless there were wells making less than 30 times as much water as oil that would have been improved by corrective work, but, on the other hand, those making over 30 were the worst offenders, and it was of these therefore that especial studies were undertaken. In most cases those pumping less than 30 times as much water as oil can be easily handled by average power, but with a ratio over 30, they are apt to break off and fall behind.

These wells with ratios over 30 were carefully gaged again, and the graphic logs reexamined, except in those cases where the wells pound down or pump off and it is known that they are producing at full capacity. Recommendations were then made, on the basis of the gages and logs, in cooperation with the officials of the respective companies.

RECOMMENDATIONS FOR REPAIR WORK ON WELLS

In view of the fact that most of the wells gaged were producing water in large quantities, it is desirable to give primary consideration to those wells that seemed to be most severely handicapped by the water. As stated, it was arbitrarily determined to give preferential consideration to those wells making as much as, or more than, 30 barrels of water to each barrel of oil produced, unless owing to other determining circumstances, such as the physical condition of the well and previous work done on it, it appeared not wise to adhere to this ratio.

The map, of which Plate XII is a copy, was drawn and blue prints of it were distributed among the officers of the various companies concerned. With these data in hand, conferences were held with foremen and superintendents in charge of the properties, as to the most practicable methods of reducing the amount of water produced by the various wells. Each well was, of course, considered individually, taking into account such circumstances as past history. In short, all data pertaining to or tending to indicate the condition and characteristics of each individual well were obtained and discussed at these conferences, as a result of which, recommendations for repairing wells were made in writing to the various companies. A summary of these wells and of the recommendations is shown in Table 10.

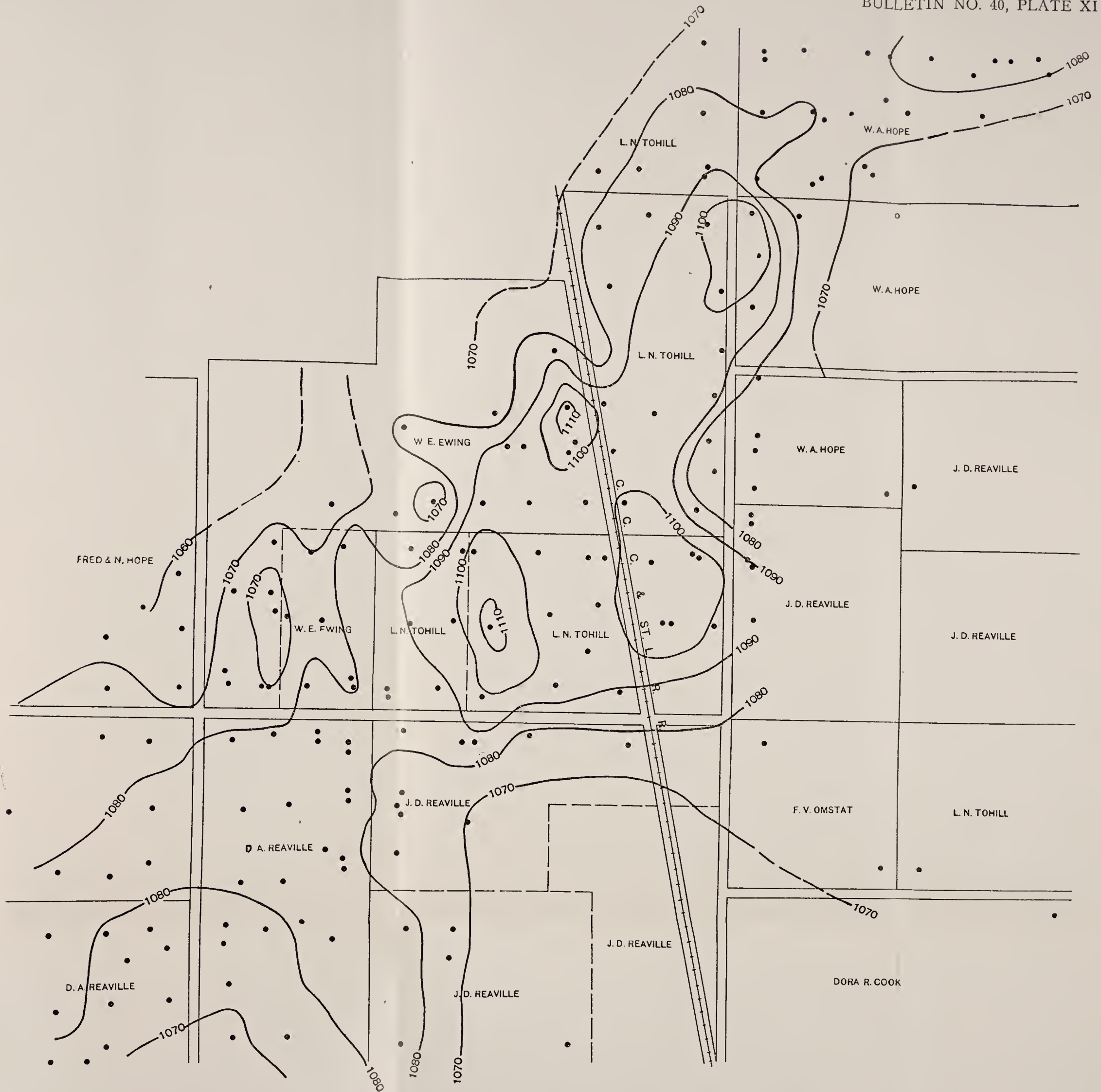

Map showing the structure on the surface of the Flat Rock sand in a portion of the Flat Rock pool

GAGING AFTER REPAIRS

After repair work had been completed upon the several wells, a series of gage readings was taken to show the extent of improvement made and the tendency of the well to revert to its original condition. As long as the investigating party was in the field, these readings were taken at regular intervals. Small at first, the time interval between measurements was gradually lengthened as the amount of change grew less and less. On Tohill No. 4, for example, the gage on the second day was 35 barrels and five days later it had dropped to less than half of that. After that the decline was much more gradual. On the Ewing No. 8, Selby and Cisler, the gage started at 65 and dropped rapidly to 35 and then gradually to 30 barrels.

While the Survey party was gaging the wells, the "three-barrel siphon" setup was used. Later after the party left the Flat Rock district, when the oil companies did the gaging themselves, as a check upon the gages of the Survey, they ran the entire production of the wells into a 250-barrel stock tank, drained, steamed, and gaged, and obtained almost identical figures. This method of gaging was lengthy, more cumbersome, and of course could not be used daily without tying up the whole lease as well as the time of the pumper. The results should be just as accurate with the barrel gage as the stock tank gage, for on the one hand the chance is that there will be a little water measured as oil, while on the other, gaging a five-barrel run in a 250 tank is not conducive to accuracy beyond the closest barrel. The only thing in favor of the complete daily gage is that while the error in the siphon barrel gage is collective and grows larger and larger, the gage in the tank is compensating, being first over and then under the true production.

A summary of the results of the corrective work has already been given as Table 8.

LOSS OF PRODUCTION INCIDENT TO DELAY IN REPAIRS
ON WELLS

Considerable production is often lost by delaying the repairs on a well after trouble has been observed. In one such well in the Illinois fields it is estimated that \$1,500 worth of oil was lost in two and a half months by delaying repair work. While some of this oil might be regained when the well was finally repaired, much of it would not be recovered, and it is obvious that if such a method of procedure be generally followed on a lease, one can not hope for a fair recovery of oil from the properties.

TABLE 10.—Summary of Recommendations for Repairs to Wells

Company	Farm	Well	Production— Bbls. per 24 hours		Ratio Water Oil	Recommendations
			Water	Oil		
Central Refining Co.....	L. N. Tohill	15	103	.9	115.	Set packer
		9	152	3.7	41.	Lower packer, if need be recase
		17	209	12.2	17.1 ^a	Set packer, if packer showed improvement recase—if not cement 2 feet
James Pease & Co.	W. E. Ewing	4	140	0.	^b
		5	94	1.7	55.3	^b
Ohio Oil Co.....	L. N. Tohill	4	459	6.9	66.5	Clean out; cement 3 feet
		5	350	6.1	57.4	Clean out; cement 2 feet
		7	102	2.8	36.4	Clean out; cement 3 feet
		10	47	.1	470.	Recase
		13	85	2.1	40.5	Postpone recommendation
		14	148	1.8	82.2	Clean out; repair casing and if casing is good cement 4 feet
		15	68	2.3	29.5 ^a	Postpone recommendation
Selby and Cisler Producing Co.	W. E. Ewing	1	47	0.	Test with packer; if necessary recase
		5	70	1.7	41.1	Test with packer; if necessary set small string inside on hemp packer
		7	170	1.5	113.3	Reset packer; repair casing; if necessary clean and cement 2 feet
		27	145	2.9	50.	Reset packer; if tight, cement 1 foot if can be done without mov- ing casing
		31	187	2.9	64.5	Make packer test, then recase; if packer does not help, cement.

^a Wells under the 30 ratio which are tabulated for other reasons.

^b No work was recommended to be executed on the wells of James Pease and Company since operations had been too irregular due to the shortage of gas for operating power.

TESTING TO DETERMINE SOURCE OF INCOMING WATER

USE OF VENETIAN RED AS AN INDICATOR

Well No. 7 of the Selby and Cisler Company, on the W. E. Ewing lease, had a packer set on tubing in the lower portion of the 6¼-inch string. This string had been corroded sufficiently to let in the upper water. In order to get evidence as to whether the water in the well was from the bottom or was leaking around the packer, water was run into the casinghead, and Venetian red (chiefly red oxide of iron) was poured into this connection along with the water. A watch was kept on the production to determine if any of the indicator got past the packer. The finely divided Venetian red being carried in suspension and not in solution would not be suitable for use as an indicator when the fluid had to pass through a sand or other filtering medium. As used for testing, the effectiveness of a packer when the water is entering the well in large volumes, or tests of a similar nature, Venetian red was considered satisfactory as a substitute for aniline dye, which was formerly imported and only to be obtained at a prohibitive price at the time of the test. In the case of this particular well, the dye was not pumped out. While such negative evidence even in this type of a case is not conclusive, it is a strong indication that the packer was holding.

USE OF PACKERS AS A TESTING DEVICE

Though packers are not recommended as a suitable device for permanently excluding water from an oil or gas well, they are often useful as a temporary expedient, and as a testing device for determining the source of the water entering the well. By setting the packer in the bottom joint of the casing with the pump above and with a perforated nipple between the packer and pump, a quicker and more positive test of the condition of the casing may be obtained. Of course, for such a method the bottom of the tubing must be plugged. When the casing seat is to be tested, a similar arrangement of perforated nipple, pump, and plug may be used, only the packer must be set below the bottom of the casing. By this method the test is made by pumping out the fluid from above the packer instead of from the sands.

METHODS OF WATER CONTROL

USE OF MUD FLUID

The use of mud fluid for controlling high-pressure gas wells and as a protection against the ill effects of unsystematic casing in nearby wells has been thoroughly discussed by Lewis and McMurray.¹ In the

¹ Lewis, J. L., and McMurray, W. F., The use of mud-laden fluid in oil and gas wells: U. S. Bureau of Mines Bull. 134, 1916.

State of Illinois it is proposed to use mud fluid for two purposes—to arrest the corrosion of casing by water cased off back of it, and to avoid

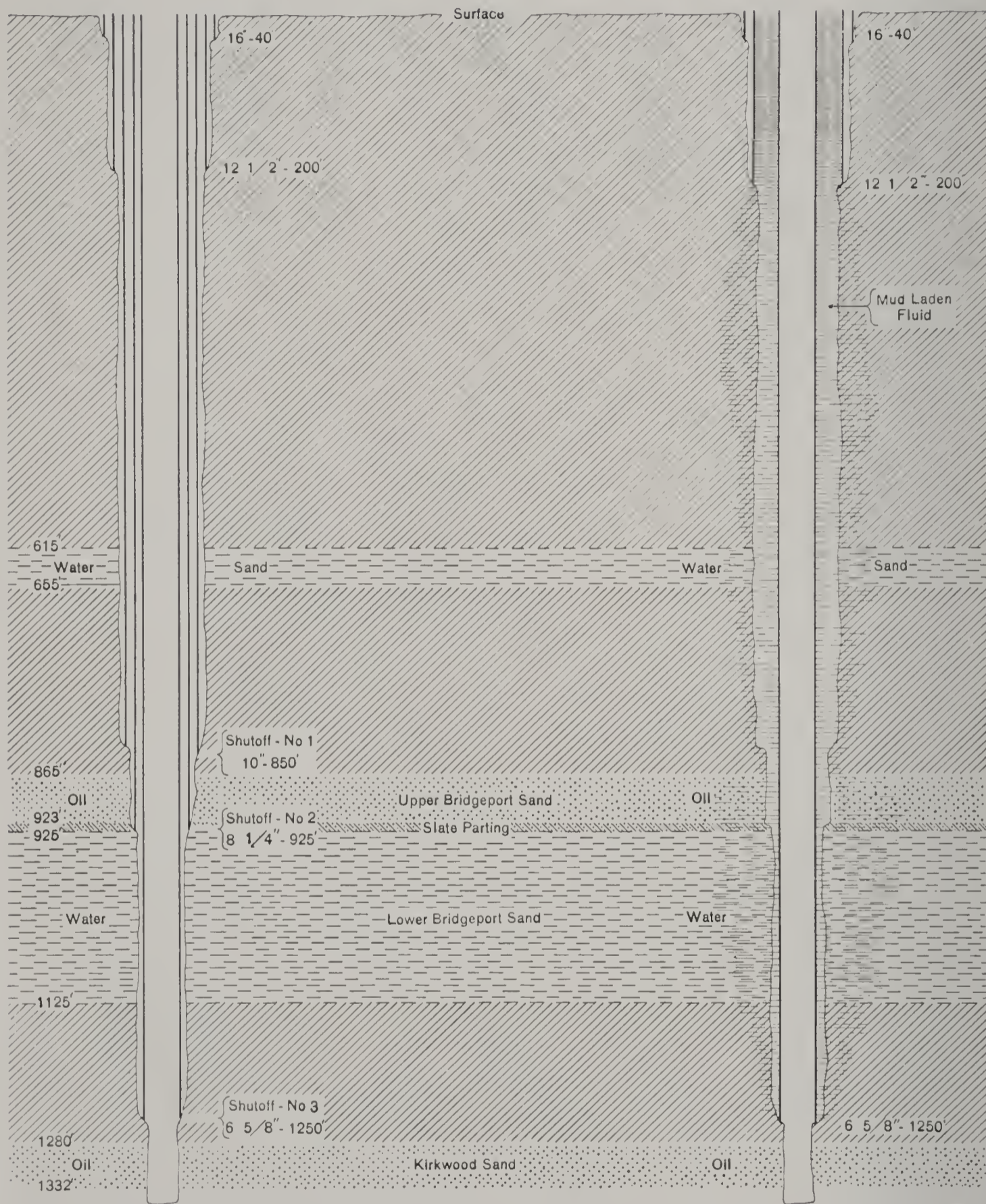

Fig. 31. Diagram to show the saving in casing accomplished by the use of mud fluid.

the detrimental effects of unsystematic casing. The chemical and geological aspects of corrosion have been described on a previous page. It remains now to consider the mechanical phases of the problem.

THE MUD

To be most effective the mud fluid must consist of colloidal material, free from grit, sand, or lime cuttings. Such granular material tends to settle around the outside of the casing and to bridge or pack over the collars, not only interrupting the continuity of the column of mud fluid, but



Fig. 32. Photograph showing the connection at the top of the well between the discharge of the mud pump and the casing in the circulation method. The outgoing mud fluid has been down through the casing, out its bottom, and is returning to the surface, outside the casing.

possibly freezing the casing. If air is excluded from such a mud fluid, it will remain fluid indefinitely and with comparatively small amount of settling. The thicker the original mud fluid is used the less will be the subsequent settling. As general rule it is advisable to mix the mud as thick as the pumps will handle it.

METHODS OF MUDDING WELLS

Since the mudding procedure is identical whether the purpose is to obviate the necessity of three shut-offs, or to arrest corrosion, this discussion of methods is applicable to either case. There are, in general, three methods for mudding:

1. Jet the hole full of mud; insert and land the casing.
2. Run casing into the hole and hang the pipe a few feet off the bottom. Jet the pipe full of mud until the column equalizes inside and outside of the casing at the surface; then set the casing.
3. Run casing into the hole and pump it full of mud. Make a closed connection between the discharge of the mud pump and the top of the casing, and continue pumping until the mud fluid descending inside the casing and returning to the surface in the space between the casing and the wall of the hole is free from cavings, sand, or lime cuttings, and is of the same specific gravity as the ingoing fluid. (See figure 32.) Then land the casing.

Whichever method is adopted, the mud fluid should not be bailed out of the pipe for at least 24 hours after completion of the job.

A ditch or flume some 50 to 100 feet long should be arranged and the mud fluid run through it to afford opportunity for all coarse material to settle out (figs. 33-35.) It should terminate in a suction pit so placed that the suction line of the pump may be easily transferred from the sump to the suction pit when mudding operations are commenced. In the circulation process of mudding, when the mud returns to the surface outside the casing, it may frequently contain cuttings and cavings washed up from the hole; and therefore before it has returned to the suction pit it should be allowed to flow through the trench so that such coarse material may settle out. This ditch must be shoveled out at intervals.

Frequently enough clean mud fluid for the job will be collected at the lower end of the mud sump. The necessary specific gravity may be obtained by providing an overflow so that the excess water which rises to the surface of the sump will run off. If sufficient clean mud is not collected in this way at the lower end of the sump, an additional supply may be obtained by drawing the clean mud fluid from the lower part of the sump and forcing it through a flexible discharge pipe into the coarser settlings at the upper end of the sump with which it is mixed. Thus the high-pressure stream of mud may be used as a hydraulic monitor, and, by circulating the mud fluid through the pump and ditch, all colloidal matter available is brought into suspension.

SUGGESTIONS WITH REGARD TO CASING

As none but good casing should be mudded, it will stand having the joints well set up. The threads inside the coupling and on the ends of the casing joints should be thoroughly cleaned and threaded with lead and oil or some other suitable preparation before the joints are started.

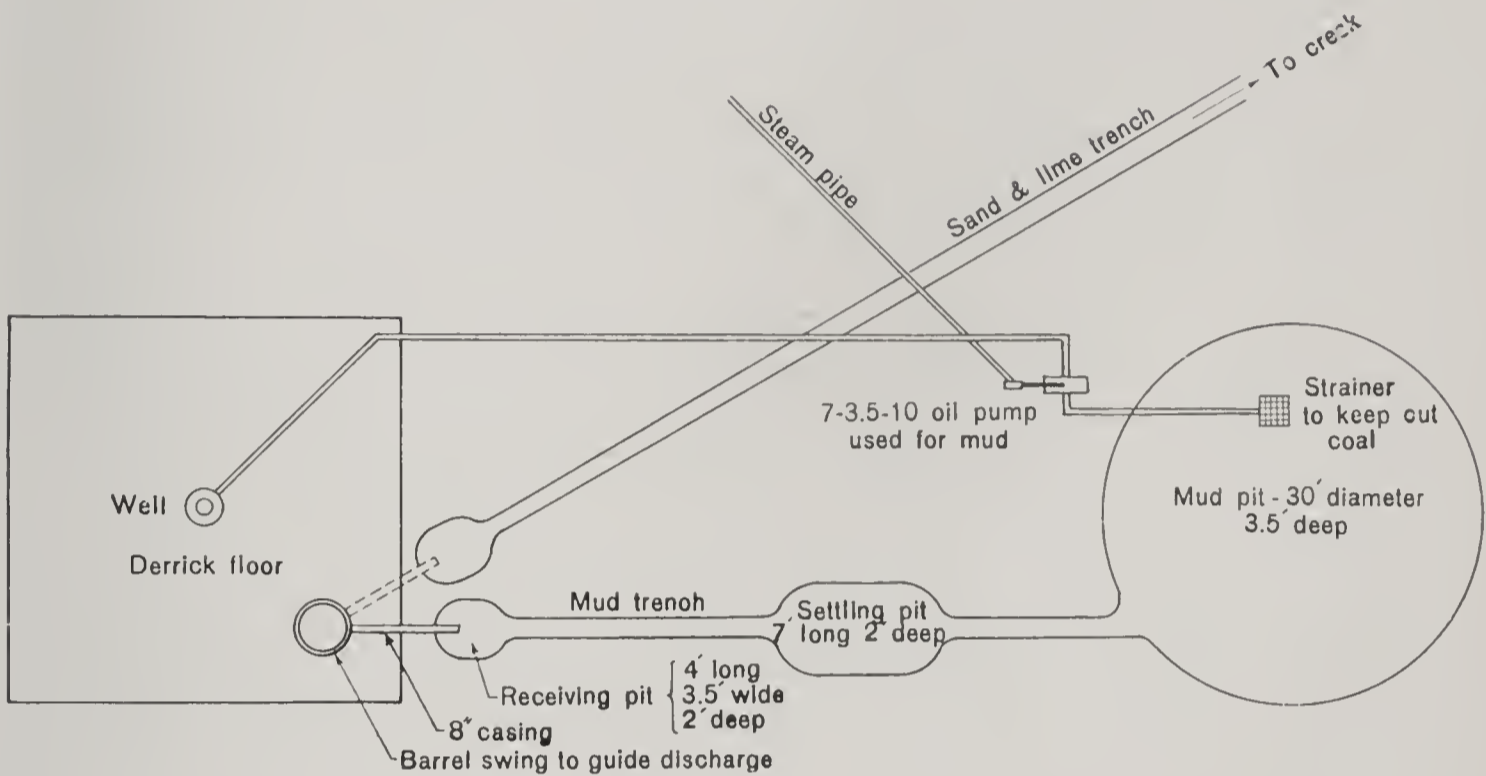

Fig. 33. Diagram showing the system used in collecting mud for mudding Selby-Cisler well, Ewing No. 6B.

Whenever suitable tongs are available, the casing should be set up with the engine. By taking these precautions the strings will hang together and stand more severe stress in case jacks have to be used to free it during any future operation.

When mudding casing by pump and circulation methods as described, it should be raised and lowered at intervals without interrupting the action of the pump. This vertical movement of the casing should not be less than 22 feet so that each coupling will pass the position formerly occupied by the next above. This process tends to prevent accumulation of debris on the wall of the hole which might cause the pipe to become collar-bound and to stick or "freeze."

While very little trouble has been experienced in other states in pulling casing which has been set with mud fluid, nothing but experience can demonstrate whether or not such mudding operations will be as fortunate in this respect in Illinois. Nevertheless if experience should show that it is impossible to recover mudded strings of casing after prolonged standing, the operator will have been reimbursed many

times for this loss of pipe, providing the mudding excludes upper water from the productive sands throughout the life of the well. It is on this argument that the use of mud is recommended in Illinois at the present time.

Another precaution to be observed, especially in "spotty" territory, is to set the water string, drill into the pay sand, and if necessary to shoot the well before mudding. If then the well is to be abandoned, it is obviously unnecessary to mud the water string, but the mud saved for this purpose while drilling can be used to good advantage in properly plugging the hole. On the other hand, if the well shows up favorably when drilled into the sands, it is a simple matter to bridge the hole above the sands and lift the pipe, mud, and reseal the casing.

APPLICATION TO REPAIR PROBLEMS

CORROSION OF CASING AND METHODS OF PREVENTION

There are areas in the Illinois pools where the rapid corrosion of casing necessitates frequent renewals. In some instances casing and well tubing must be replaced after two years' service. These replacement jobs are not only costly in themselves, but the financial loss is considerably augmented by the incidental loss of production both while the well is off and by the diminished output of the well when returned to the producing status, an occurrence which frequently accompanies such water jobs. While this reduction in productivity is not universal, it is a very general characteristic of such troubles in other fields as well as those of Illinois. It has been observed that when water breaks into an oil or gas well, permanent damage is frequently occasioned, and that the well will frequently not come back to its former productivity even after the water has been shut off.

To prevent the corrosion of casing, two methods of procedure are open; first, to use casing of such composition that it will not be corroded, and, second, to keep the corrosive agent from contact with the casing.

Numerous efforts have been made by pipe manufacturers to supply non-corrosive casing, which have been but partly successful. As a rule such special casing is more costly than ordinary pipe.

To keep the corrosive agent from contact with the pipe is the method of greatest promise at present. One way to achieve this is by filling the space between the casing and the wall of the hole with mud fluid and to set the casing so as to retain the mud in this annular space throughout the life of the well. This method, of course, did not originate with the present investigation, but merely constitutes the application of a well-known principle to a particular set of conditions. The method has been used successfully in many fields and depends for its success on two

properties of mud fluid—first, the clogging action of the fluid as it enters the interstices of a sand, which tends to convert the porous sand locally into an impervious sandy clay, and second, the static pressure exerted by the column of mud fluid, which will continually oppose the pressure tending to force water through the sand into the well and into contact with the casing. Suppose, for the sake of illustration, that a water sand penetrated at a depth of 1,000 feet is cased and mudded off by such a process as that subsequently to be described, and suppose that the specific gravity of the mud is 1.25, that is to say, 25 per cent heavier than pure water. Suppose also that the water has sufficient head to rise 600 feet in the hole, or within 400 feet of the surface. This head of water is equivalent to 260 pounds pressure per square inch. In opposition to this pressure of water tending to enter the hole is the



Fig. 34. Photograph of the mud sump taken from the top of the derrick on Selby-Cisler well, Ewing No. 6B.

pressure exerted by 1,000 feet of mud fluid, which exerts a counter-pressure of 541 pounds per square inch. Thus the pressure exerted by the mud tending to hold the water back is 281 pounds greater per square inch than the pressure of the water in the sand.

The result is that some mud enters the sand, as stated, until sufficient resistance has been built up to balance the extra pressure of the column of mud and a state of equilibrium is obtained. By such a mud system, various fluids native to strata cased off are retained in their normal re-

spective stratigraphic positions and are thus prevented from migrating up and down the hole to contaminate fluids of other strata. Also, if any of these fluids are directly or indirectly responsible for the corrosion of the casing, such corrosion is very likely to cease.

One of the most striking facts in connection with the corrosion of casing in the Illinois fields is that the bottom joints of a water string rarely show corrosion when the casing is pulled. So general is this circumstance that of the many oil men interviewed on the subject, not one had failed to observe it, and all attributed the fact to the protection afforded by shale cavings from the hole which settled about this portion of the pipe. The use of mud fluid may therefore be considered as extending similar protection throughout the full length of the string.

INTERMEDIATE WATER AND ITS CONTROL

In many oil fields there are areas where intermediate water is encountered. By this term is meant a water-bearing stratum with productive oil or gas strata above and below it, and with "breaks" of impervious strata separating the several sands. When it becomes desirable to produce from the lower productive stratum a competent operator at once adopts means to protect the upper productive stratum from becoming flooded by the intermediate water, as would be the case if both the intermediate water and upper oil were cased off behind the same string of pipe.

One method of doing this is the three shut-off system consisting of three strings of casing; one set above the upper productive strata and another below it, thus protecting it from upper and intermediate waters, while the third string is set above the second producing sand.

This method is open to the following objections: It is costly, due to the extra strings of casing used, as well as the labor involved. It offers only temporary protection in contact with corrosive agents. If the first or second shut-offs fail before the third, the water will then spread in the upper productive sand and perhaps spoil adjacent wells producing from it. Since under conditions of three shut-offs production from the lower sand in the offending well may not be diminished by the spread of water in the upper sand, the true source of the water may not be determined. Moreover, if the well at fault is making a good production from the lower pay an operator would be reluctant to pull the casing from such a well on a chance that the first or second shut-offs were at fault. Being only human, he might prefer to claim the benefit of the doubt rather than to risk spoiling a good well because of a suspicion that it might be causing damage to the upper sand. It is therefore of prime importance that first and second shut-offs, and for that matter,

every shut-off in drilling wells, should be made as nearly permanent as possible, having due regard for all factors and complications likely to arise in the future, as far as past experience may indicate them.

It has been recommended to some of the companies operating where intermediate water is encountered, that one string of casing be thoroughly mudded and landed above the lower pay; and the other strings that might be necessary while drilling should be pulled, keeping fluid level of the mud outside the water string as near the surface as possible at all times. Of course, in some cases, it will be advisable, for mechanical reasons, to leave some conductor pipe in the hole in addition to the one string that is mudded. Such conditions are shown in figure 31, an Indian Refining Company well in the Petrolia district. To the left the well is shown as it would normally be cased, and to the right as



Fig. 35. Photograph of the mud sump looking toward the derrick. Trench near the center in which coarse material settles out; suction and mixing pipes at the right, the former below the latter.

it would be if mud fluid were used. The saving here is in the cost of the strings of pipe. Due to the pressure tending to collapse a string of pipe, which is exerted by a column of heavy mud fluid, old or very thin casing should not be used in mudding operations.

USE OF CEMENT

Use of cement in oils wells is confined to repair work in so far as water control is concerned.

The method of cementing off lower water as used extensively in the Illinois field, was first introduced by W. W. McDonald of the Ohio Oil Company. It is adapted to completed wells which have been drilled too deep, or in which the shot has introduced salt water, as well as to those which have been partially flooded as a result of the inevitable encroachment of the water upon the field, due to extraction of the oil.

MCDONALD METHOD OF CEMENTING BOTTOM WATER

A string of two-inch tubing, plugged tightly with a wooden plug, is lowered to within a foot or so of the prospective top of the cement. Fresh water is run into the tubing until it is filled, and the bottom plug is knocked out with sucker rods or by striking the upper end of the water column. Fresh water is then allowed to run into the well for several hours to force any salt water back into the sands. Cement is introduced by the handful into the stream of water, preferably heated to 130°, until the amount desired has been put in. The water flow is continued but in a smaller stream, merely enough to keep the circulation from the well outward, so as to hold the cement grains in the interstices of the sand, rather than from the salt reservoir toward the well, which would force the cement back into the well. The water flow should be kept up for six or eight hours. With ordinary cement the well should not be pumped sooner than the eighth day.

There is a great difference in cements, and the cement used should be tested in a great excess of water before putting it in the well, to determine whether or not it can be depended on to set under such conditions.

INDEX

	PAGE		PAGE
A			
Acknowledgments	22, 52, 104	Clinton County, drilling in....	15
Adams County, geology and structure of.....	69-90	Coal City, seepage of oil and gas near	17
physiography of.....	71-72	Coghill, John W. Jr., assistance of	52
stratigraphy of.....	86-96	Colchester coal, <i>see</i> No. 2 coal.	
<i>Agaricocrinus tuberosus</i> , occurrence of in Keokuk limestone	94	Coles County, drilling in.....	12-13
Alluvial deposits in Brown County	25	Colmar-Plymouth fields, drilling in	16
in Pike and Adams counties	86	Corrosion of casing, prevention of	137-138
Analyses of oil-well waters....	114-117	Corrosive waters in Flat Rock Pool	111-113
of Pike County gas.....	83	Crawford County, drilling in..	14
<i>Archimedes</i> , occurrence of in Warsaw formation.....	94	Cumberland County, drilling in	12, 18
Artesian wells.....	86	D	
Ava, drilling near.....	16-17	Devonian rocks in Brown County	38-39
B			
Benville, Keokuk formation near	37	in Goodhope and La Harpe quadrangles	53-59
Bond County, drilling in....	17	in Pike and Adams counties	95
Brown County, physiography of recommendations for drilling in	49-50	Douglas County, drilling in....	18
stratigraphy of.....	25-40	Drilling, record of.....	18-20
structure of	41-46	E	
Burlington limestone in Brown County	38	<i>Echinoconchus alternatus</i> , occurrence of in Keokuk limestone	94
in Goodhope and La Harpe quadrangles	53-59	Edgar County, drilling in.....	12
in Pike and Adams counties	94	Edwards County, drilling in..	17
Bushnell, dome near.....	65	<i>Endothyra baileyi</i> , occurrence of in Salem limestone....	38
log of well at.....	56-57	Ewing well No. 6, log of.....	108-109
C			
Calhoun County, Kimmswick-Plattin limestone in.....	96	F	
Campbell Hill anticline, drilling on	16-17	Fair Weather, section near....	91
Carbondale formation in Brown County	28-29	Fayette County, drilling in....	17
in Flat Rock Pool.....	110	"First lime"	38
in Pike and Adams counties	89-91	Flat Rock Pool, geology of....	106-113
Casing, corrosion of.....	105	peg model of.....	118-119, 121
saving of by use of mud fluid	132	water trouble in.....	106
Central Refining Company, assistance of	104	Flat Rock sand	112-113
Chestline, section near.....	91	Fossils, occurrence of in Keokuk limestone	37, 94
Clark County, drilling in.....	12-13	in St. Louis limestone.....	31
		in Salem limestone.....	33, 93
		in Warsaw formation.....	94
		Friendsville Township, drilling in	14

	PAGE		PAGE
G			
Gaging of wells in Flat Rock Pool	121-129	Key horizons for Brown County for Goodhope and La Harpe quadrangles	23-24
Galena-Platteville limestone, in Goodhope and La Harpe quadrangles	53-59	for Pike and Adams counties	64
possibility of oil production from	61	for Pike and Adams counties	72-73
Gallatin County, drilling in..	16	Kimmswick-Plattin limestone in Brown County.....	39-40
Gas in glacial drift.....	66-67	in Pike and Adams counties	96
in Pike County.....	75-84	Kinderhook shale in Brown County	38
"Gas sand", 600-foot, in Flat Rock Pool.....	110, 111	in Goodhope and La Harpe quadrangles	53-59
Glacial drift, gas in.....	66-67	in Pike and Adams counties	95
in Brown County.....	26-27	L	
in Flat Rock Pool.....	107	La Grange, section near.....	30
in Pike and Adams counties	87	La Harpe Quadrangle, stratigraphy of	53-59
Gochenour well, log of.....	58-59	structure and oil possibilities of	51-57
Goodhope Quadrangle, stratigraphy of	53-59	Lawrence County, drilling in..	14
structure and oil possibilities of	51-67	<i>Lioclema</i> , occurrence of in Warsaw formation	94
H			
Hancock County, drilling in..	16	<i>Lithostrotion</i> , occurrence of in St. Louis limestone.....	31
Hazelwood, section near.....	93	Loess deposits in Brown County in Flat Rock Pool.....	107
Hoing sand	73-74	in Pike and Adams counties	86-87
correlation of	39, 40	M	
possibility of oil production from	60-61	McDonald method of cementing oil wells.....	140
in Goodhope and La Harpe quadrangles	53-59	McDonough County, drilling in	16
I			
Illinoian till, distribution of	26-27, 87, 107	McLean County, drilling in....	17
Illinois, rank of in oil production	9-10	McLeansboro formation in Flat Rock Pool	110
structure of	63	Macoupin County, drilling in..	15
Illinois oil, prices of.....	11	Madden, Frank J., assistance of	104
Illinois Pipe Line Company, assistance of.....	104	Madison County, drilling in... ..	17, 18
Indian Refining Company, assistance of	104	Maquoketa shale in Brown County	39
J			
Jackson County, drilling in... ..	16-17	in Goodhope and La Harpe quadrangles	53-59
J. and L. Parke well, log of..	47	in Pike and Adams counties	92-95
Jasper County, drilling in....	12	possibility of oil production from	41, 61
Johnson County, drilling in... ..	16	Marion County, drilling in....	15-16
Johnson well, log of.....	47	May wells, logs of.....	48
K			
Keokuk formation in Brown County	37-38	Mink, Jerry, assistance of....	71
in Goodhope and La Harpe quadrangles	53	"Mississippi lime"	38
in Pike and Adams counties	94	Mississippian rocks in Goodhope and La Harpe quadrangles	53-59
		in Pike and Adams counties	92-95
		Morgan County, drilling in....	17
		Morse, W. C., work of.....	22
		Mount Sterling, Pottsville formation near	30, 31
		St. Peter sandstone in well at	40
		Mudding, methods of.....	134-135
		Mud fluid, use of in water control	132-138

	PAGE		PAGE
N			
Natural gas, <i>see Gas</i> .		<i>Productidae</i> , occurrence of in Carbondale formation.....	90
Nebel, M. L., work of.....	71, 104	<i>Productus burlingtonensis</i> , oc- currence of in Burlington limestone	94
Niagaran limestone, gas from in Brown County.....	83-84 39	<i>Productus magnus</i> , occurrence of in Keokuk limestone...	94
in Goodhope and La Harpe quadrangles	53-59	R	
in Pike and Adams counties	95	Randolph County, drilling in..	17
possibility of oil production from	40, 41, 60	Recommendations for oil tests	49-50, 65, 84-86
Northern Illinois, drilling in..	17	for repair work.....	128
No. 2 coal as key horizon in Brown County	23-24	Repair work, use of cement in..	139-140
in Goodhope and La Harpe quadrangles	63	use of mud fluid in.....	137-139
in Pike and Adams counties	72-73	losses resulting from delay of recommendations for in Flat Rock Pool	129 128
O			
Oakland, drilling near.....	13	Rich, J. L., work of.....	22, 23
Oil, character of in Flat Rock Pool	114	Ripley dome	46
Oil-producing horizons ...	40-41, 59-61	Robinson sand in the Flat Rock Pool	110
Ordovician rocks in Brown County	39-40	Roseville, dome near.....	65
in Goodhope and La Harpe quadrangles	53, 61	S	
in Pike and Adams counties.	95-96	St. Louis limestone in Brown County	31-32
P			
Packers, use of as indicator of source of water.....	131	in Pike and Adams counties	92-93
Parke well, log of.....	47	St. Peter sandstone in Brown County	40
Parrish well, log of.....	57-58	Salem limestone, fossils in....	33
Pennsylvanian rocks in Brown County	28-31	occurrence of in Brown County	24, 32-35
in Flat Rock Pool.....	107-113	in Pike and Adams counties	93
in Goodhope and La Harpe quadrangles	52	Saline County, drilling in.....	16
in Pike and Adams counties	89-92	"Salt sand, 600-foot", <i>see</i> " <i>Up- per salt sand</i> ".	
Perry County, drilling in.....	17	Savage, T. E., work of..	22, 33, 52, 83
Petroleum, prices of in 1916, 1917, and 1918	10-11	Schuyler County, drilling in..	16
number of wells drilled for in 1917 and 1918.....	12, 18-20	"Second lime"	39, 73
production of, 1905 to 1918..	10	Section of hard rocks in Brown County	27-28
1917 and 1918.....	9-20	in Goodhope and La Harpe quadrangles	52-53
production of decreasing in Illinois	99	in Pike and Adams counties	87-89
Pike County, drilling in.....	16, 76-80	of Pennsylvanian rocks in Flat Rock Pool.....	108
geology and structure of....	69-96	Selby and Cisler Refining Com- pany, assistance of.....	104
natural gas in.....	75-84	Shinn, Claude, assistance of...	71
physiography of	71-72	Single-barrel gage, description of	121
stratigraphy of	86-96	South central Illinois, drilling in	15-16
Pittsfield-Hadley anticline	75-84	Southeastern Illinois, drilling in	12-14
Plymouth field, drilling in.....	16	Southern Illinois, drilling in..	16-17
Plymouth oil, prices of.....	11	Spanish Needle Creek Dome, drilling on	15
Pottsville formation in Brown County	30-31		
in Pike and Adams counties	91		
in Flat Rock Pool.....	110		
possibility of oil production from	59		

	PAGE		PAGE
<i>Spirifera</i> , occurrence of in Keokuk limestone	94		
<i>Sporangites huronense</i> , occurrence of in Devonian shale	38		
Staunton gas pool, decline of	15		
Stratigraphy of Pike and Adams counties	86-96		
Stronghurst, dome near.....	64		
log of well at.....	55		
Structure of Brown County....	41-46		
of Flat Rock sand.....	113		
of "gas sand" in Flat Rock Pool	111		
of Goodhope and La Harpe quadrangles	63-66		
of Pike and Adams counties.	74, 75, 81-86		
Structure, relation of to oil accumulation	43-44, 62, 73		
Sweetland Creek shale in Goodhope and La Harpe quadrangles	53-59		
T			
Tests for oil, Brown County..	46-48		
Goodhope and La Harpe quadrangles	66		
Three-barrel siphon gage, description of	121-124		
"Trenton limestone", see <i>Galena-Platteville limestone and Kimmswick-Plattin limestone</i> .			
		U	
		Upper Devonian shale in Brown County	38
		in Goodhope and La Harpe quadrangles	53-59
		in Pike and Adams counties..	95
		"Upper salt sand" in Flat Rock Pool	111-112
		V	
		Venetian red, use of as indicator of source of water..	131
		W	
		Wabash County, drilling in....	14
		Warsaw formation in Brown County	36-37
		in Pike and Adams counties	93-94
		Washington County, drilling in	17, 18
		Water, amounts pumped in Flat Rock Pool	128-129, 130
		ill effects of on oil wells....	104-106
		Water control work, results of.	101-104
		Water Survey, cooperation with	104
		Well data for Pike County gas field	83-84, 76-80
		Weller, Stuart, work of.....	22, 38, 71
		Wells, flowing	86
		Western Illinois, drilling in...	16

L. A. MYLIUS

STATE Geological Survey

Urbana, Ill

LIBRARY OF CONGRESS

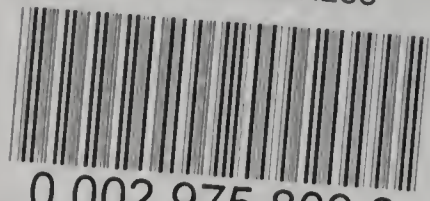

0 002 975 809 8