

C.O. Ⓟ
X.O. I

ANALYSIS OF EXISTING MARINE FENDERING SYSTEMS
AND ANALYSIS OF A MARINE FENDER SYSTEM
UTILIZING TORSIONAL RESISTANCE

A THESIS

E. Malfanti

Thesis
M2782

LIBRARY
NAVAL POSTGRADUATE SCHOOL
MONTEREY, CALIF. 93940

ANALYSIS OF EXISTING MARINE FENDERING SYSTEMS
AND ANALYSIS OF A MARINE FENDER SYSTEM
UTILIZING TORSIONAL RESISTANCE

A THESIS

SUBMITTED ON THE THIRTY-FIRST DAY OF JULY, 1970

TO THE DEPARTMENT OF CIVIL ENGINEERING

OF THE GRADUATE SCHOOL OF

TULANE UNIVERSITY

IN PARTIAL FULFILLMENT OF THE REQUIREMENTS

FOR THE DEGREE OF

MASTER OF SCIENCE

BY

TABLE OF CONTENTS

	Page
LIST OF FIGURES	iv
INTRODUCTION	vi

PART I. MARINE FENDERING SYSTEMS

Chapter		
I.	BERTHING FORCES	2
	Kinetic Energy of the Ship	
	Virtual Mass of Vessel in Water	
	Eccentricity Factor	
	Softness Factor	
	Configuration Factor	
	Nomograph	
II.	MOORING FORCES	16
	Wind Forces	
	Current Forces	
	Wave Forces	
	Tidal Forces	
	Earthquake Forces	
III.	FENDER SYSTEMS	29
	Fender Piles	
	Hung Type Fenders	
	Resilient Fender Systems	
	Suspended or Gravity Fender Systems	
	Retractable Fender Systems	
	Separators or Floating Fenders	
IV.	DESIGN CRITERIA	53
	Data Evaluation	
	Selection of Type of Fender	

PART II. ANALYSIS OF A MARINE FENDER SYSTEM

Chapter	Page
V. PRELIMINARY ANALYSIS	59
Long Piles Working in Torsion	
Torsional Rubber Buffer	
Torsional Rubber Buffer with Steel Shaft	
Coaxial Tubes in Torsion	
VI. MATHEMATICAL ANALYSIS OF COAXIAL TUBES IN TORSION	68
Stress-strain Relationship	
Statical Analysis	
Dynamical Analysis	
VII. TORSIONAL RUBBER BUFFER DESIGN	80
Materials	
Design Example	
VIII. CONCLUSIONS	103
LIST OF REFERENCES	106

LIST OF FIGURES

Figure	Page
1. Ship Striking the Wharf	5
2. Eccentricity Factor, C_e	9
3. Nomograph, Energy Capacity Requirements for Fenders	14
4. Ship Motion under the Stimulus of a Seiche	23
5. Seismic Effect in Ship and Facility	26
6. Pile Fender Systems	33
7. Conventional Type of Fender-Pile Construction	35
8. Hung Fender Systems	37
9. Hanging Fenders, Cylindrical Type	40
10. Resilient Fender Systems	41
11. Cylindrical Rubber Fenders	42
12. Resilient Fender Systems, Raykin Type	43
13. Buckling Column Type Buffer	45
14. Suspended-Gravity Fender, Concrete Block Type	47
15. Pendular Shock-Absorbers (Mantelli patent)	47
16. Suspended-Gravity Fender System	48
17. Retractable Fender System, Blancato Type	50
18. Separators or Floating Fenders	52

Figure	Page
19. Typical Load-Deflection Curves for Different Types of Buffers	56
20. Long Cantilever Pile Working in Torsion	61
21. Torsional Rubber Buffer	66
22. Torsional Rubber Buffer with Steel Shaft	66
23. Coaxial Tubes in Torsion	66
24. Shear Stress-Strain Relationships	69
25. Relation Between Modulus of Elasticity of Rubber in Shear and Durometer Hardness Number	69
26. Coaxial Tubes in Torsion	71
27. Ship Striking the Buffer	73
28. Key Chart to Elastometers Compound	81
29. Physical Requirements of Type R Compounds	83
30. Contact Length, Ship Striking Wharf	85
31. Coaxial Tube Rubber Buffer, Statical and Dynamical Load-Deflection Curves	90
32. Coaxial Tube Buffer Details	99
33. Load-Deflection Curves for Different Types of Marine Fenders	102

INTRODUCTION

Fendering port installations was for many years considered a necessary evil. The main purpose of the fenders was the protection of the piers from damage by berthing vessels. The fenders did little to neutralize the heavy forces acting upon the piers and vessels.

Today, with a better understanding of the forces involved and with better methods of handling these forces, the marine engineering industry has made the fender system a major item in the design of a pier. By doing this, it is possible to take full advantage of the efficiency of the system and tailor the pier structure to meet the requirements of forces greatly reduced by the energy-absorption capacity of the fender.

In the past, with smaller vessels to be berthed than those now in service, wood fender piles performed satisfactorily. However, the low energy-absorption capacity for this system makes it unsuitable for larger ships. Therefore, new types of fenders have had to be developed to keep pace with the ocean engineering field of the present.

Without improved fendering there is a greater risk of damage to the ship, particularly since the modern ship with its wider spaced frames is more susceptible than older vessels to damage on contact with the structure.

When existing piers have to be revamped to accommodate larger vessels than those for which the piles were originally designed, modern fender systems present a tremendous advantage. Frequently, the structural capacity of the pier is adequate, so that no structural changes are necessary. The new fendering is designed to absorb the extra energy of the larger vessel while the pier loading forces remain the same as they were originally.

In a new pier design, the proper cost relationship between the pier and the fender is a very important factor. Fender systems depend on the energy-absorption capacity required and on the type of pier or wharf. For instance, a flexible pier that will deflect under berthing forces will dissipate much of the vessel's kinetic energy. On the other hand, if the pier is rigid, the fender system must be designed to absorb the total berthing impact force. Further, a properly designed fender system may permit a less costly pier design if the fender is permitted to dissipate the load and properly distribute the reactions into the pier structure.

PART I

ANALYSIS OF EXISTING MARINE FENDERING SYSTEMS

CHAPTER I

BERTHING FORCES

A wharf structure to serve ships should be designed to perform three principal functions:

1. Support the equipment necessary for the loading and/or unloading of cargo

2. Resist the berthing or breasting forces of the ship

3. Resist the mooring forces of the ship

Function (1) will not be analyzed in this paper. The present chapter will be related to function (2), but more specifically to the study of the berthing forces.

The berthing forces vary with the following factors:¹

1. Mass of the vessel

2. Hydrodynamics (or virtual mass) of the vessel

3. Velocity of approach of the vessel

4. Angle of approach of the vessel with reference to the face of the structure

5. Distance between the point of impact and the center of the ship's mass

6. Rigidity of the vessel and the fender system or the breasting system

7. Waves, currents, and wind that may be present at the time of docking

In evaluating the impact energy imparted to the wharf by a berthing vessel, the kinetic energy approach is generally preferred. In this approach, the impact energy is a function of the vessel's mass and velocity.

As far as berthing forces are concerned, generally the wind, current, and wave forces are not taken into account; however, they will govern the captain's selection of velocity and angle of approach.

The energy transmitted to the fender system at the time of impact and which produces a berthing force perpendicular to the pier is:²

$$E = E_0 \cdot C_m \cdot C_e \cdot C_s \cdot C_c \quad (1)$$

where E = energy absorbed by the fender, lb-ft

E_0 = kinetic energy of the ship, lb-ft

C_m = mass factor

C_e = eccentricity factor

C_s = softness factor

C_c = pier configuration factor

KINETIC ENERGY OF THE SHIP

The kinetic energy of the vessel at the time of impact is given by the fundamental equation

$$E_0 = 1/2 M v^2 = 34.8 W v^2 \quad (2)$$

where E_o = kinetic energy of the ship, lb-ft
 W = displacement of the vessel, long tons
 v = velocity of approach, ft/sec

For calculations concerning berthing forces, the ship is assumed to be fully loaded.

The velocity, v , is the speed of approach normal to the pier, that is, at right angles to the line of the pier face. The angle of approach is generally taken as 10° and the velocity normal to the pier is generally 0.5 ft/sec although environmental conditions can vary the velocity to as much as 1.0 ft/sec. Larger vessels usually are considered to have a velocity less than the smaller class of vessels, due to the greater difficulty in maneuvering these ships.

The approach velocity considered for fender design is dependent upon the location of the facility and the conditions of approach. Listed below are values published by Baker in 1953 in Rome at the International Congress of Navigation. These values were accepted in 1955.

Accordingly, in practice today, when berthing with tug assistance the following approach velocities perpendicular to the berth should be taken into account.

Position	Approach	Berthing velocity perpendicular to berth, ft/sec		
		1500 DWT	7500 DWT	15000 DWT
Strong wind & waves	Difficult	2.5	1.8	1.3
Strong wind & waves	Favorable	1.97	1.48	1.0
Moderate wind & waves	Moderate	1.48	1.15	0.66
Protected	Difficult	0.82	0.66	0.49
Protected	Favorable	0.66	0.49	0.33

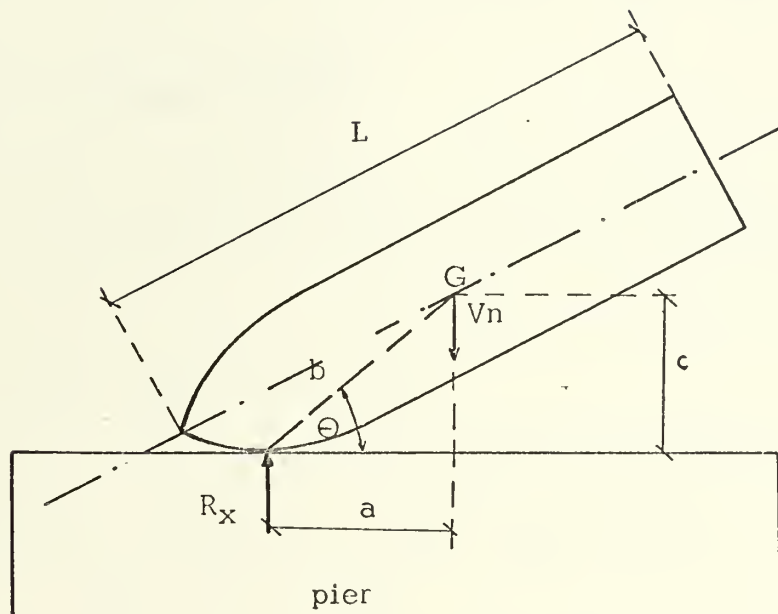

Fig. 1 .SHIP STRIKING THE WHARF

For larger vessels most designers use 0.33 to 0.5 ft/sec approach speed (normal to the pier) for design purposes. It should be noted that the shipping companies utilizing large (supertanker) vessels have established berthing procedures with velocities within these limits.

VIRTUAL MASS OF VESSEL IN WATER

In the case of a vessel floating in water its effective mass may be expected to be greater than its mass in air due to the hydrodynamic mass of the water which moves with the ship. The effective mass is usually called the "virtual mass," M_m .

The virtual mass of the vessel is equal to the mass of the vessel in air, M_v , plus the "hydrodynamic mass," M_h . That is,

$$M_m = M_v + M_h \quad (3)$$

The "hydrodynamic mass" is the mass of the water associated with the berthing ship. The hydrodynamic mass does not necessarily vary with the mass of the ship, but is more closely associated with the projected area of the ship at a right angle to the direction of motion. The hydrodynamic mass, however, is generally considered as

$$M_h = C_h M_v \quad (4)$$

where the "hydrodynamic coefficient," C_h , depends upon the draft and beam of the ship³

$$C_h = \frac{2 D}{B} \quad (5)$$

where D = draft of the ship, ft

B = beam of the ship, ft

Using Eqs. (3), (4), and (5) it is now possible to solve for the value of the "mass factor," C_m .

$$C_m = \frac{\text{Virtual Mass}}{\text{Mass of the ship}} \quad (6)$$

$$= \frac{M_v + C_h M_v}{M_v}$$

$$C_m = (1 + C_h) \quad (7)$$

Typical values for the coefficient, C_m , using the above method lie between 1.3 and 1.8. Saurin,⁴ working with models of supertankers, found that in varying the clearance under the ship, the value of the mass factor varied. Also Saurin found that for a specific clearance under the ship (in this case, 3 ft), the mass factor has a critical value over 3. This value was substantially greater than when the clearance is either very small or quite large. However, when Saurin began full scale observations, he found that the value of the mass factor was approximately 1.3. This value agrees with the range of values given by Eqs. (5) and (7).

ECCENTRICITY FACTOR

Just how much of the gross kinetic energy, E_o , of a berthing ship at a given approach velocity is delivered to the fender system at any point of impact depends upon how much of the entire mass is effectively acting. In the case of an impact taking place with a non-parallel docking approach, the normal velocity vector, v , acting at the mass center of the ship, does not coincide with the reaction vector, R , acting at the point

of contact. Therefore, the mass center is free to continue moving; thus, only a fraction of the whole mass is acting.

Fig. 1 shows a ship with mass M , radius of gyration k , length L , and with its center of gravity at G , approaching an elastic fender at X with a transverse velocity, v . The angular velocity of the ship about the point X is w . The angular velocity is expressed in radians per second.

According to the "principle of conservation of moment," the moments of momentum instantly before and after the impact contact are almost equal.⁵

$$\text{Thus, } M v (b \cos \theta) = M \bar{k} w (\bar{k}) \quad (8)$$

$$w = \frac{v b \cos \theta}{\bar{k}^2} \quad (9)$$

$$k = \sqrt{I/A} \quad (10)$$

where w = angular velocity, rad/sec

b = distance between the center of mass and the impact point, ft

θ = angle between the line b and the face of the fender, degrees

\bar{k} = radius of gyration with respect to the point of contact, ft

I = moment of inertia, ft⁴

A = cross-sectional area of the ship, ft²

The effective energy absorbed by the fender should be equal to the gross kinetic energy minus the energy of rotation of the ship.

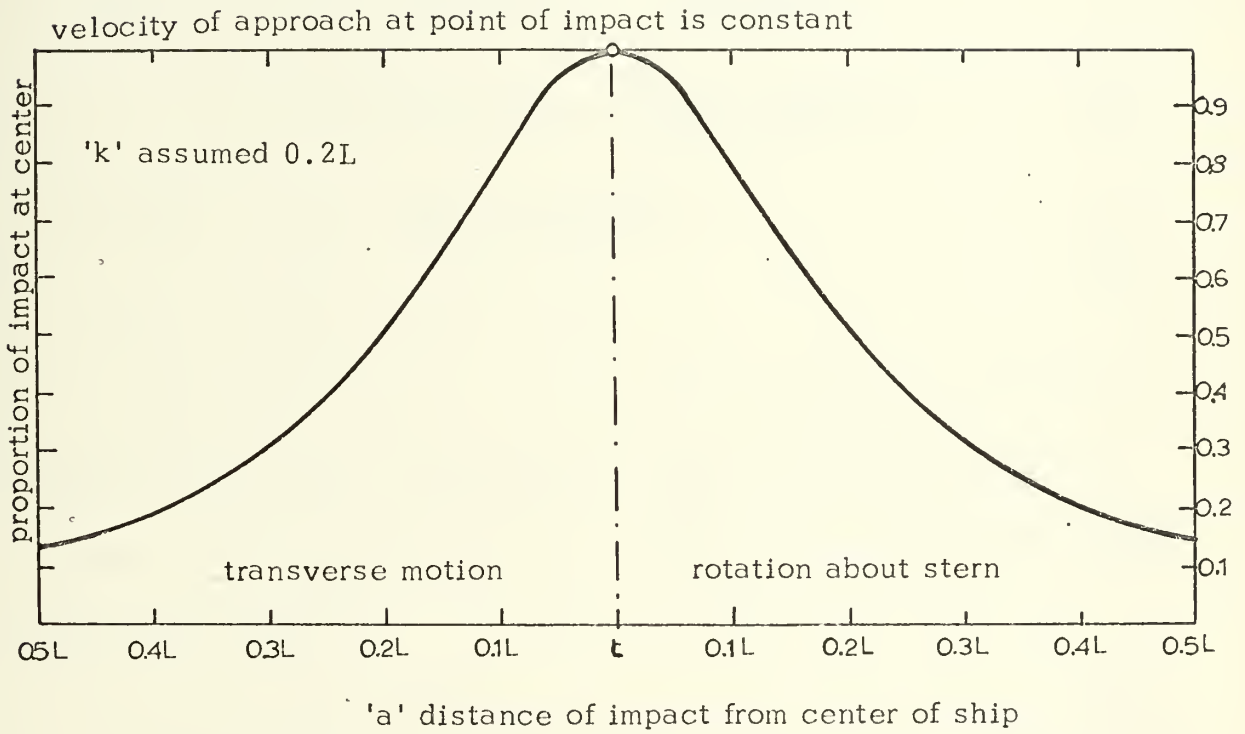
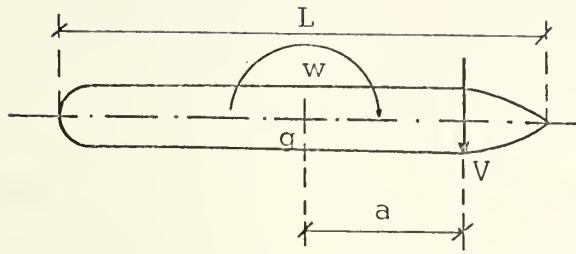

Fig.2. ECCENTRICITY FACTOR C_e .

$$\begin{aligned}
 \text{Therefore, } E &= 1/2 M v^2 - 1/2 M (\bar{k} w)^2 \\
 &= 1/2 M \left(v^2 - \bar{k}^2 \frac{v^2 b^2 \cos^2 \theta}{\bar{k}^4} \right) \\
 &= 1/2 M v^2 \left(1 - \frac{b^2 \cos^2 \theta}{\bar{k}^2} \right)
 \end{aligned}$$

The radius of gyration, \bar{k} , is referred to as the point of contact.

Using the radius of gyration, referred to as the mass center of the ship,

k , we have

$$\bar{k}^2 = k^2 + b^2$$

$$\text{and } E = 1/2 M v^2 \left(1 - \frac{b^2 \cos^2 \theta}{k^2 + b^2} \right)$$

$$E = 1/2 M v^2 \left(\frac{k^2 + b^2 \sin^2 \theta}{k^2 + b^2} \right) \quad (11)$$

$$\text{where } C_e = \frac{k^2 + b^2 \sin^2 \theta}{k^2 + b^2} \quad (12)$$

$$\text{Thus, } E = 1/2 M v^2 C_e$$

In the case of large wall-sided vessels, the radius of gyration about the mass center is approximately equal to 1/4 of the length L of the ship. If we assume b equal to one-third of the length and the angle θ equal to 27.8 degrees

$$C_e = 1/2 \quad (13)$$

For all values of θ smaller than 27.8 degrees, the energy absorbed by the fender system, E , will be less than 1/2 the gross kinetic energy, E_0 , if the above values of k and b remain the same.

Shu-t'ien Li remarked:

While it is reasonable to take half of the mass as acting in the case of wall-sided vessels of 20,000 tons class or over, the effectively acting proportion of the entire mass will increase as the displacement tonnage decreases, and this proportion may be increased to nearly the full mass in the case of belted vessels of the 2,000 ton class or under.

The belted vessels are generally built more curved in plan and sometimes with completely curved beltings capable of delivering the whole impact as a concentrated load on the face of the fender. These vessels are sturdy and can resist a much greater localized reaction than a wall-sided vessel without suffering from plastic deformation. Consequently, not only may they deliver the full gross kinetic energy to the fender system, but also they usually berth at a much higher speed, thus making their kinetic energy as high as, or even slightly higher at times than, a large wall-sided vessel of ten times the tonnage displacement.⁶

Large ships such as supertankers approach the pier at a very small angle and so Eq. (12) can be rewritten as

$$C_e = \frac{k^2}{k^2 + a^2} \quad (14)$$

where "a" is the distance between the center of mass of the ship and the point of impact measured parallel to the pier (see Fig. 1).

Saurin⁷ has a complete mathematical approach to the Coefficient of Eccentricity for supertankers. Treating the supertankers as a rigid rod of negligible breadth, he derives the same Eq. (14).

As was pointed out earlier, the approximately theoretical value of the radius of gyration for a wall-sided vessel is 0.25L; however, recent studies of full scale models recommend the use of 0.20L as the radius of gyration.

Values of the eccentricity factor according to Eq. 14 for an assumed value of "k" of 0.2L were plotted by Saurin and are shown in Fig. 2.

SOFTNESS FACTOR

When a ship strikes a fender and compresses it, the ship will suffer a local elastic deformation, absorbing a specific amount of energy. With relatively small ships this energy is not taken into account in fender design.

In practice, with large ships it is customary to use fairly soft fenders and it is apparent from the observations by the British Petroleum Company, Ltd. that the deflection of the ship's side is small compared with that of the fender. Consequently it is usually assumed that 90% of the energy of impact is absorbed by the fender and only 10% by the ship.

Thus, for

$$\text{Small ships, } C_S = 1.0$$

$$\text{Large ships, } C_S = 0.9$$

CONFIGURATION COEFFICIENT

This factor provides for the water cushion effect between the pier and the ship and is generally assumed to be:

$$\text{Closed pier } C_C = 0.8$$

$$\text{Semi-closed pier } C_C = 0.9$$

$$\text{Open type pier } C_C = 1.0$$

NOMOGRAPH

The Lord Manufacturing Company developed a nomograph to find the energy capacity requirements for marine dock fenders. The nomograph is shown in Fig. 3.

The interpretation of the nomograph is:

The nomograph presents the solution to a typical problem in fender selection. The vessel is a supertanker with a displacement of 80,000 tons, 110 ft beam and 38 ft draft. Approach velocity is 0.3 ft/sec. Berthing coefficient is 0.5.

To relate these values to the energy absorption requirement, the first step is to find the hydrodynamic mass, M_H . This is expressed as $M_H = C_H M_V$, where C_H is the hydrodynamic coefficient and M_V is vessel mass. The procedure is as follows:

1. Find the hydrodynamic coefficient by drawing a line between the known values of draft and beam on scales 2 and 4 ($C_H = \frac{2D}{B}$).

The hydrodynamic coefficient is the point of intersection on scale 3.

2. Locate the hydrodynamic mass on scale 5 by drawing a line from the known displacement value on scale 1 (which converts tonnage displacement to mass) through the point previously established on scale 3.

The next step is to determine total kinetic energy. This is expressed as $E = 1/2 M_E V^2$, where M_E is effective mass and V is velocity. Observe these procedures:

1. Locate the effective mass on scale 6 by adding vessel mass to hydrodynamic mass

$$(M_E = M_H + M_V).$$

2. Find total impact energy on scale 8 by drawing a line from the established point on scale 6 through the known velocity on scale 7.

The final procedure is to establish the energy absorption requirement with the equation $E_A = C_B E$. Berthing coefficient, C_B , is equal to $C_e \cdot C_C \cdot C_O$:

C_e - is the eccentricity coefficient which may vary from 0.14 to 1.0 and is expressed as:

$$C_e = \frac{k^2}{b^2 + k^2}$$

k = ship radius of gyration about the axis - frequently 0.20 to 0.29 times the ship's length

b = distance between the point of impact and the ship's center of gravity

C_C - is the configuration coefficient and may be assumed equal to 0.8 for closed pier, 0.9 for semi-closed type and 1.0 for an open type. This factor provides for the water cushion effect between the pier and ship.

Fig. 3 NOMOGRAPH, ENERGY CAPACITY REQUIREMENTS FOR FENDERS
(Lord Manufacturing Co. Bulletin 800-C)

VESSEL DISPLACEMENT 1000 TONS

VESSEL MASS MV
 DRAFT FT D
 HYDRODYNAMIC COEFFICIENT CH
 BEAM FT B
 HYDRODYNAMIC MASS MH
 EFFECTIVE MASS ME = MH + MV
 VELOCITY FT/SEC V
 ENERGY FT KIPS E
 BERTHING COEFFICIENT Cp
 ENERGY TO BE ABSORBED BY FENDERS EA

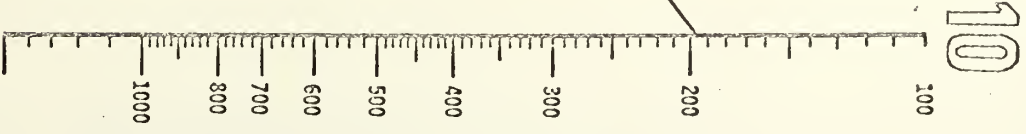
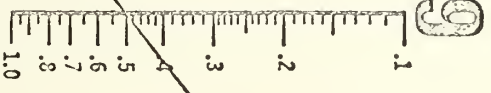
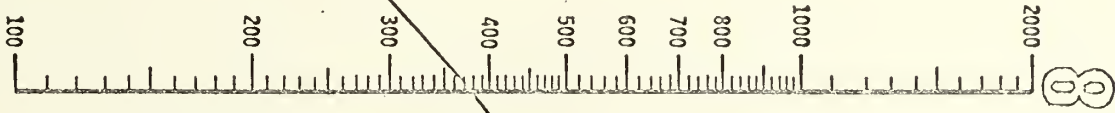
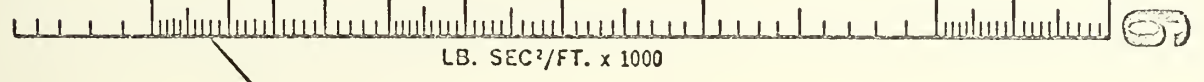
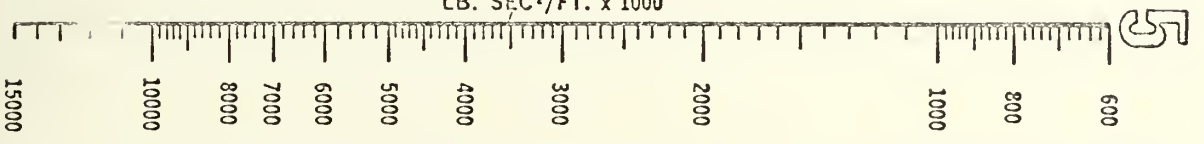
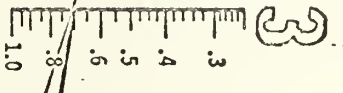
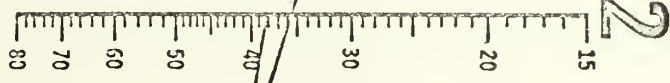
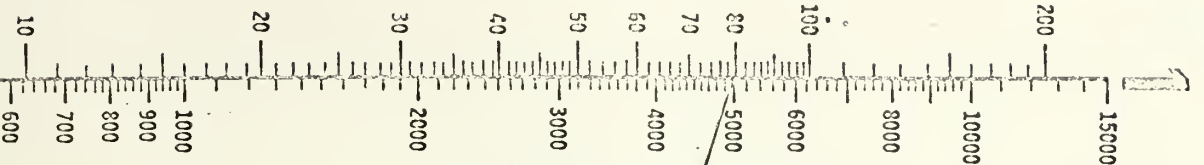

Velocity normal to pier at point of impact.
 Energy calculated in short tons. Increase by 10% if long ton displacement is desired.

C_o - is the coefficient to allow for contingencies such as elastic deformation of the hull, and other factors influencing the berthing impact.

The berthing coefficient, C_B , is quite often assumed to be 0.5 where insufficient information is available to allow evaluation of the individual coefficient. The equation $E_A = C_B E$ can be solved on the nomograph by this step:

Determine energy to be absorbed on scale 10 by drawing a line from the established point on scale 8 through the known berthing coefficient on scale 9.⁸

CHAPTER II

MOORING FORCES

Except in sheltered waters, the mooring forces may be considerably greater than those occurring during a well controlled berthing.

Mooring forces are transferred to the structure by the vessel bearing thereon or by the tension in the mooring lines.

The mooring forces vary with the following factors:

1. Atmospheric disturbances
2. Dynamic pressure of the currents
3. Drag force or frictional resistance
4. Pull under the stimulus of a seiche
5. Surge motion-progressive waves
6. Tidal fluctuations
7. Waves produced by other moving vessels in the basin
8. Seismic disturbances wherever they are active

For convenience, these forces may be divided into their longitudinal and transverse components. Generally, because the resulting force does not act at the center of mass of the ship, a bending moment is produced about the center. These moments are very small when the angle of attack is 0° or 90° , and are maximum when the angle is approximately 45° . For any angle of attack, it appears sufficiently accurate to

calculate the forces at angles of 0° and 90° and to apply the sines and cosines to compute the components at other angles.

The evaluation of the mooring forces should be made for two conditions - vessel loaded and vessel light.

WIND FORCES

The direction of the wind is given by the point of the compass from which the wind comes toward the observer. The side of the structure facing the direction from which the wind comes is the "windward" side and the opposite side is the "leeward" side.

The pressure of the wind varies with the square of the velocity and is given by the formula

$$p = c v^2 \quad (15)$$

where p = pressure of the wind, psf

c = constant, for air = 0.00256

v = velocity of the wind, mph

The total wind pressure on the structure varies with its shape. Therefore, the pressure "p" is multiplied by a factor varying between 1.3 and 1.6. The smaller value is usually adequate for the low, flat surface of a ship or dock.

The design wind velocity should be the maximum velocity of wind averaged over a time period of five minutes. Except under special circumstances, design wind velocity should not exceed 88 mph (maximum pressure 20 psf). During times of greater storms, it may be assumed

that the vessel will put to sea or take on ballast to reduce the wind area.

Total wind force is obtained by multiplying the intensity or wind pressure by the vertical projected area of the ship perpendicular to the direction of the wind. Under situations where wind directions toward the bow or stern are to be used, a reduction of wind force intensity may be made recognizing that the bow is angle-shaped and the stern is curved-rounded.

The wind force is given by

$$R_w = 0.00256 k v^2 A_w \quad (16)$$

where R_w = wind force, lb

k = shape factor, varies between 1.3 and 1.6

v = velocity of the wind, mph

A_w = projected area perpendicular to the wind, ft²

A large number of tests on models of comparatively small vessels have been made by the United States Navy at the David Taylor Model Basin on wind forces. Woodruff⁹ presents the following equations which closely agree with the results found. The equations are as follows:

Longitudinal force, wind on bow

$$R_{we} = 0.45 q_a A_{we} \quad (17)$$

Longitudinal force, wind on stern

$$R_{we} = 0.50 q_a A_{we} \quad (18)$$

Lateral force, wind on beam

$$R_{wl} = 1.10 q_a A_{wl} \quad (19)$$

Maximum moment, wind at 45°

$$M_w = 0.08 R_{wl} L \quad (20)$$

where R_{we} = longitudinal force, wind, lb

R_{wl} = lateral force, wind, lb

M_w = wind moment about center of vessel, ft-lb

A_{we} = projected area, longitudinal wind, ft²

A_{wl} = projected area, transverse wind, ft²

L = length of the ship, ft

q_a = stagnation pressure, air = $0.0034 v^2$, when
wind velocity is in knots

For angles other than those shown, sine curves may be assumed.

CURRENT FORCES

The total "current force" on the ship hull is composed of two parts. The dynamic head " R_d " of the current striking the vertical projection of the submerged part of the hull and the frictional resistance " R_f " on the wetted perimeter.

The dynamic force, R_d , can be evaluated using the conversion

$$h = \frac{p_c}{w_\gamma} = \frac{v^2}{2g} \quad (21)$$

$$p_c = \frac{(1.69 v_c)^2}{2g} \quad 64.4$$

$$p_c = 2.86 v_c^2 \quad (22)$$

where h = hydrostatic head, ft
 p_C = intensity of pressure, psf
 w_Y = unit weight of sea water, 64.4 pcf
 v_C = velocity of the current, knots (1.69 fps)
 g = gravity acceleration, 32.2 ft/sec²

To obtain the dynamic force, the pressure, p_C , must be multiplied by the projected area of the ship, A_d , normal to the direction of the current. A factor is applied because of the difference in bilge shape. The value of this shape factor, k_s , for a longitudinal hull is 1.0 and for a rounded bilge, 0.75.

$$R_d = A_d k_s 2.86 v_C^2 \quad (23)$$

where R_d = dynamic force of the current, lb
 A_d = area of the vertical projection of the hull under water, ft²
 k_s = factor which varies from 0.75 to 1.0 and depends on the shape of the underwater part of the hull
 v_C = velocity of the current, knots

The drag force or frictional resistance of the submerged hull surface area may be evaluated by Froude's equation

$$R_f = k_1 S v_C^2 \quad (24)$$

where R_f = drag force, lb
 S = area of the wetted surface, ft²
 k_1 = factor which depends upon the length of the vessel and is commonly assumed as 0.01

Woodruff¹⁰ presents the following equations based on tests conducted by the Navy on the effect of currents on moored ships. These equations consider both the dynamic and the drag forces.

Longitudinal force, current on bow

$$R_{ce} = 0.060 q_w B D (1 + D/h)^3 \quad (25)$$

Longitudinal force, current on stern

$$R_{ce} = 0.070 q_w B D (1 + D/h)^3 \quad (26)$$

Lateral force, current on beam

$$R_{cl} = 0.22 q_w L D (1 + D/h)^3 \quad (27)$$

Maximum moment about the center of the ship, current at 45°

$$M_c = 0.08 R_{cl} L \quad (28)$$

where R_{ce} = longitudinal force, current, lb

R_{cl} = transverse force, current, lb

M_c = moment from current, ft-lb

B = beam of the ship, ft

D = draft of the ship, ft

L = length of the ship, ft

h = depth of the water at low tide, ft

q_w = stagnation pressure, psf, salt water $2.64 v_c^2$
in which the velocity, v_c , is in knots

WAVE FORCES ON MOORED VESSELS

The forces on a moored vessel due to wave action are dependent upon the following factors:

1. Ratio of the wave length to ship length
2. Initial tension on the mooring lines
3. Ratio of depth of water to wave length
4. Ratio of draft to depth
5. Configuration of the ship
6. Height of fairleads above the dock
7. Displacement of the vessel

Definitive solutions to the problem of wave forces on moored objects have not been developed. It is recommended that any berth be selected in a sheltered area. Where this is not feasible, the mooring should be kept under surveillance for signs of weakness.

Wilson,¹¹ presents a theoretical solution to this problem and concludes that the worst condition occurs when the ship has a clearance between itself and the fender exactly equal to the amplitude of the on-movement. This is the worst condition because the impact will occur just as the acceleration of the ship and the water mass reach their peak.

The maximum impact force transverse to the dock from a ship lying along the longer side, D , of the dock (see Fig. 4) is given by

$$P_{\max} = \pi Y_0 W \left(\frac{2 \pi M_y^2 A_y}{B^2} + \frac{M_x A_x}{X D} \right) \quad (29)$$

If the ship is lying along the shorter side, B , of the dock, the transverse impact force is

$$P_{\max} = \pi Y_0 W \left(\frac{2 \pi M_x^2 A_x}{D^2} + \frac{M_y A_y}{X B} \right) \quad (30)$$

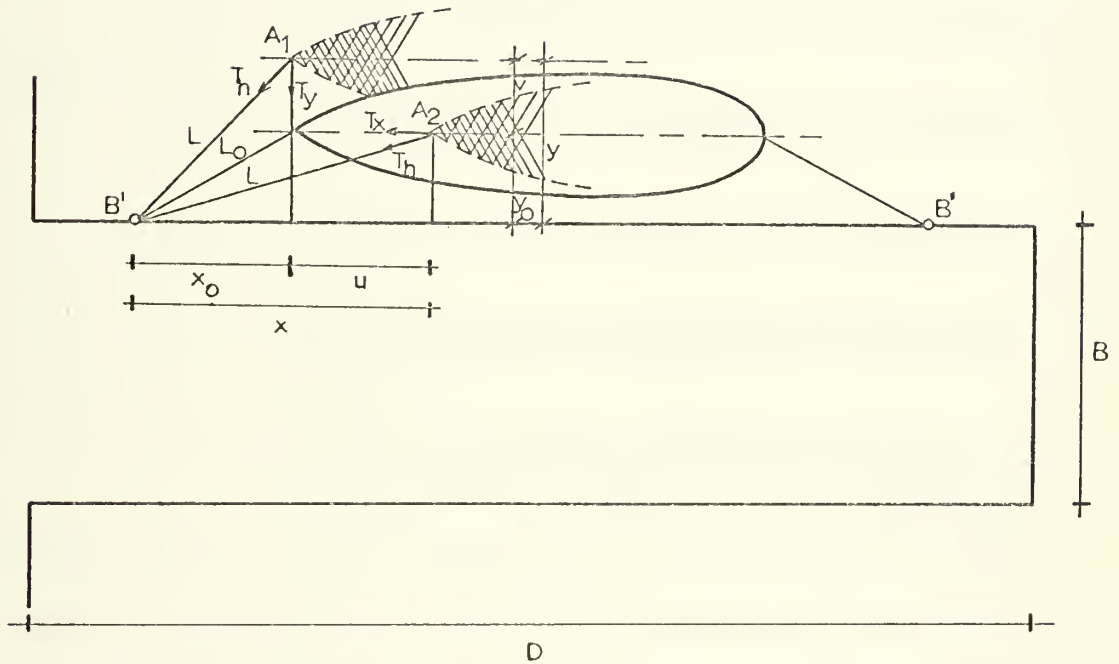

Fig. 4 SHIP MOTION UNDER THE STIMULUS OF A SEICHE
 (Ship Response to Range Action in Harbor Basins, B.
 Wilson, Transaction, ASCE, Vol. 116, 1951, Paper
 2460)

where

P_{\max}	=	transverse impact force, tons
Y_0	=	distance between center line of the ship at rest and the face of the pier, ft
W	=	displacement of the ship, tons
D	=	length of the longer side of the dock, ft
B	=	length of the shorter side of the dock, ft
M_x	=	integer defining the nodality of the longitudinal seiche
M_y	=	integer defining the nodality of the transverse seiche
A_x	=	maximum vertical amplitude of the longitudinal seiche, ft
A_y	=	maximum vertical amplitude of the transverse seiche, ft
X	=	maximum projection of the bow mooring line along the dock at which the ship is lying, ft

The first term of equations (29) and (30) represents the transverse impact under the stimulus of the seiche. The second term accounts for the additional force of the inward pull of the ship's bow or stern ropes if the ship also completes a lunge fore or aft at the instant of impact.

Wilson recalled

Since B is less than D , it is always easier for a multinodal transverse seiche to maintain itself with larger amplitude than a multinodal longitudinal seiche of the same periodicity. This fact leads to the general conclusion that Eq. 29 will always give a higher value than Eq. 30, and that damage to ship plating and harbor installations is more likely to occur at berth along the longer side of the dock.¹²

The Navy Manual NAVFAC DM-26 recommends that the normal wave forces be compensated by a "surge factor" equal to one third of the wind forces.

TIDAL FORCES

Mooring forces due to tidal fluctuations can be evaluated only for each individual situation and depend principally upon the tidal range and the initial tension of the lines.

In locations of large tidal range, mooring forces could be avoided with frequent adjustment of the ropes.

EARTHQUAKE FORCES

Seismic forces will have to be considered in an area of seismographic disturbance.

The horizontal seismic force is equal to the mass multiplied by the seismic acceleration applied at its center of gravity

$$R_s = \frac{W}{g} a = W \frac{a}{g} \quad (31)$$

where R_s = horizontal earthquake force, lb

W = dead load plus any live loads present on the structure, lb

a = seismic acceleration

g = acceleration due to gravity

Shu-t'ien-Li¹³ suggests the following values for the ratio a/g according to the Seismic Zones given in the Uniform Building Code:

SEISMIC ZONE	DEGREE OF DAMAGE	a/g
1	Minor	0.1
2	Moderate	0.2
3	Major	0.4

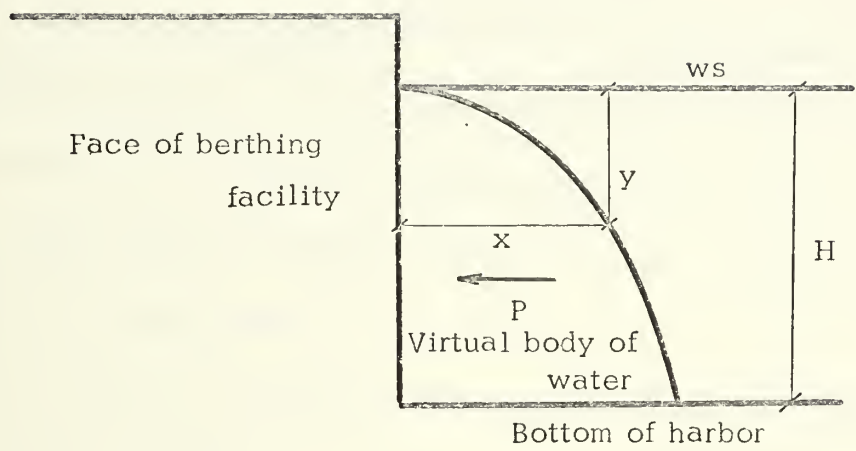

(a) Pressure on facility during back movement

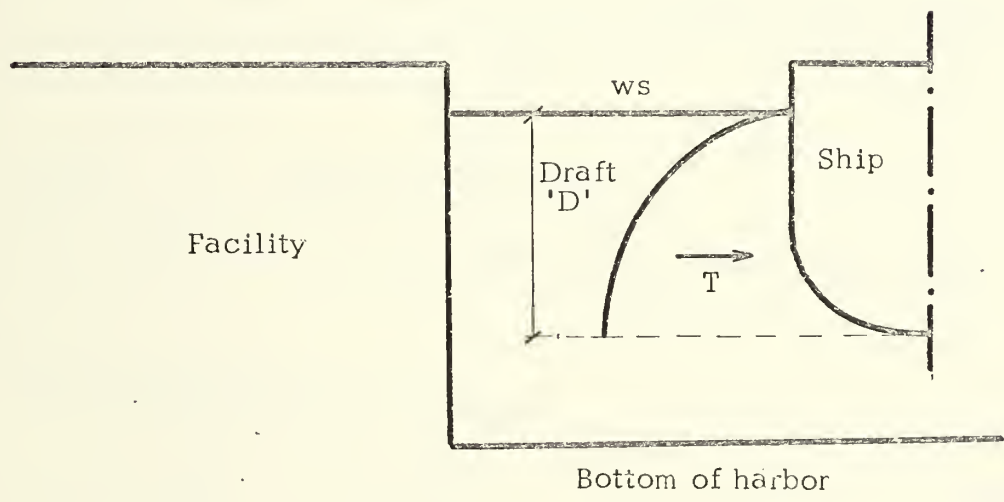

(b) Tension in mooring lines during forth movement

Fig. 5. SEISMIC EFFECT IN SHIP AND FACILITY (Shu-t'ien-Li, Waterways and Harbors Div. ASCE, Vol.88, No. WW4)

These a/g ratios are minimum values and may be increased wherever susceptible damage might be serious.

Seismic mooring forces result from the body of water in front of a facility moving back and forth with the facility while the water further away is inactive. In order to determine the mooring forces an estimate of the body of water is required, which includes the mass of the ship by virtue of displacement.

Shu-t'ien-Li¹⁴ analyzed the intensity of the seismic forces using Westergaard's study¹⁵ of water pressures behind dams caused by earthquakes. Westergaard defined the body of water as confined between the upstream face of a dam and a parabola with the origin at the point where the water surface meets the upstream face of the dam, and of the form,

$$x = \frac{7}{8} \sqrt{Hy} \quad (32)$$

where H = depth of the reservoir

Fig. 5 shows the conditions assumed by Shu-t'ien-Li, where results are

Forces and moments in the facility

$$R_s = 36.5 H^2 a/g \quad (33)$$

$$M_1 = 14.6 H^3 a/g \quad (34)$$

Tension in mooring lines and net moment about the mud line

$$T_s = 36.5 D \sqrt{HD} a/g \quad (35)$$

$$M_2 = T_s (H - 3/5 D) \quad (36)$$

- where
- R_s = force against the facility, lb per linear ft
 - M_1 = moment in the facility, lb-ft per linear ft
 - T_s = tension on the mooring lines, lb per linear ft of ship
 - M_2 = net moment about the mud line, lb-ft per linear ft of ship
 - D = draft of the ship, ft
 - H = depth of the water, ft

CHAPTER III

FENDER SYSTEMS

The contact between a berthing facility and a ship during the process of mooring or during the berthing periods may be in the form of heavy impact, abrasive action resulting from vessels rubbing against a berthing structure or direct contact pressure. Such contacts may cause extensive damage to ship and structure unless suitable means are employed for absorbing the shock, abrasion, contact pressure, or all three. Fender systems of various types have been developed for this purpose.

Some media of energy absorption such as elastic deformation of the hull, yawing of the ship at impact and displacement of water between vessel and quay were presented in Chapter 1 of this thesis. The energy absorption media mentioned previously were the softness coefficient, the eccentricity coefficient, and configuration coefficient, respectively. Other media of energy absorption which are generally not considered because they are very difficult to evaluate are the rolling of the ship at impact, deformation of the harbor bottom, wave generation and heat generated by impact.

The plastic deformation of the ship hull and the plastic deformation of the pier are two energy absorption media that both port engineers and

ship captains will attempt to eliminate or reduce to a minimum.

This chapter will be related to energy absorption by elastic deformation of the fender system.

Essential and desirable requirements of a fender system for general purpose wharves, quays, piers and jetties are enumerated by Shu-t'ien-Li¹⁶ and are as follows:

1. High absorbing capacity for impact energy so as to eliminate damages to the main structure
2. Appreciable elastic movement so as to eliminate damages to the berthing ship
3. Adaptability to both wall-sided and belted vessels to berth alongside
4. Long serviceable life, low maintenance, and least renewal
5. Minimum capital or annual cost
6. Capability of absorbing inclined impacts and rubbing forces to eliminate damage to fendering
7. Together with the main structure should have sufficient static resistance and mass to cause plastic deformation of the ship hull in order to save the main structure if hit by an abnormal impact
8. Capability of absorbing work from a bumping vessel at exposed berths
9. Avoidance of over-rigidity and stiffness
10. Relief of ship captain's fear of bumping against over-rigid fenders, which has sometimes led to the decision to cast off

The energy absorbing capacity of a fender may come from one or more of the following sources:

1. Flexural strain
2. Compressive strain
3. Shear strain
4. Torsional strain
5. Work against mass (potential energy)

Fenders are generally composed of a) the rubbing face, b) the structural frame and supports, and c) the resilient or elastic units.

The fendering is designed in units or panels for ease of replacement. The rubbing face receiving wear and tear from the ship is generally of wood timbers. White oak, greenheart, and a number of exotic hardwoods are used. The frame and supports for the rubbing timbers are of structural steel. Vertical steel piles may form a part of this frame. Alternatively, the steel frame is attached directly to the face of the wharf or hung from its deck. The elastic units are made in sizes easy to handle and replace and accessible for maintenance.

Different types of fenders have been used for diverse purposes and types of water front structures. A broad classification of the fenders is:

1. Timber pile fenders. The piles are driven straight with the butt of the pile pulled laterally at deck level. Impact energy is absorbed by the flexural and the shearing strain capacity of the fender pile.

2. Hung fender systems. These consist of timber or steel members fastened rigidly to the outboard sides of a berthing structure (see Fig. 8). They are not effective in absorbing heavy impact energy because of their limited lateral deflection and hence low capacity of internal strain energy.

3. Resilient fenders. These are fender systems consisting of a buffer or spring placed between the outboard fendering surface and the structure. The resilient medium absorbs the impact shock by compression of a rubber buffer, coil, spiral or laminated springs, or by ejection of oil or other media from an enclosed but pierced chamber.

4. Suspended fenders. These are fender systems employing gravity to absorb the kinetic energy of the moving vessel (see Fig. 14). The pressure resulting from the contact of vessels berthing against a large weight causes the weight to move inward and upward thereby absorbing a portion of the kinetic energy and reducing the horizontal force transmitted to the structure.

5. Retractable fenders. This system is a variation of the suspended fender (see Fig. 17) and utilizes the weight of the fender and the friction of the bolts on the inclined supports to absorb the kinetic energy of impact.

6. Floating fenders or separators. They were introduced to keep the ship away from the face of the wharf. They also serve as an additional cushion aiding the fenders in absorbing the ship impact (see Fig. 18). The impact energy is absorbed by deformation of the floating fender, or "camel" as they are called colloquially.

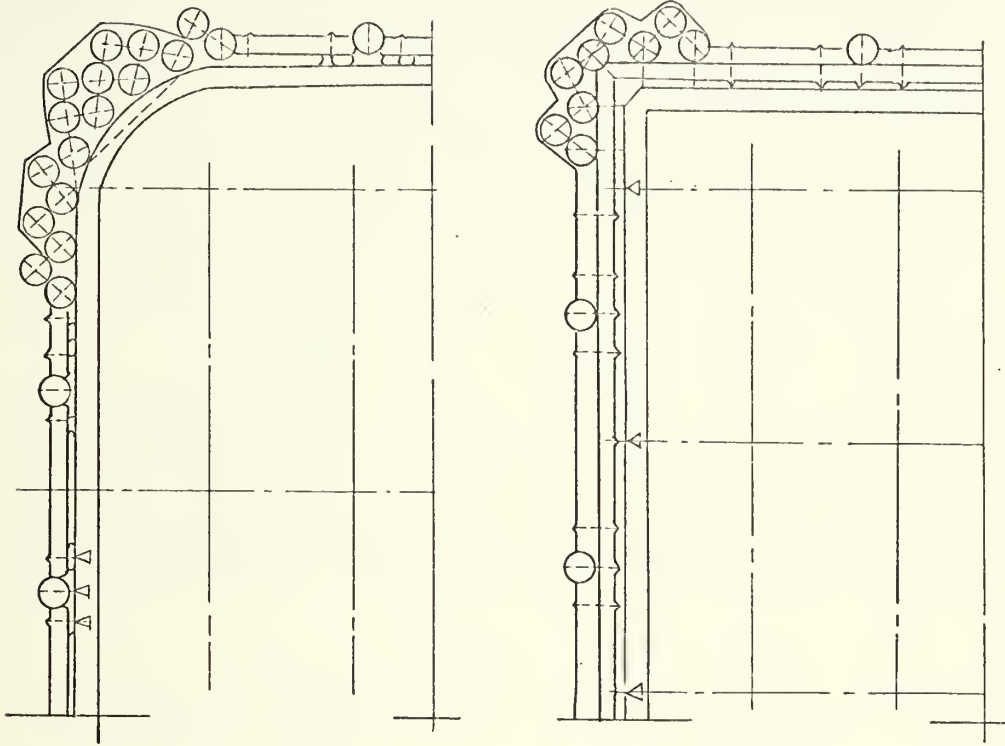

Batter
1:24

Plan

Batter
1:24

Plan

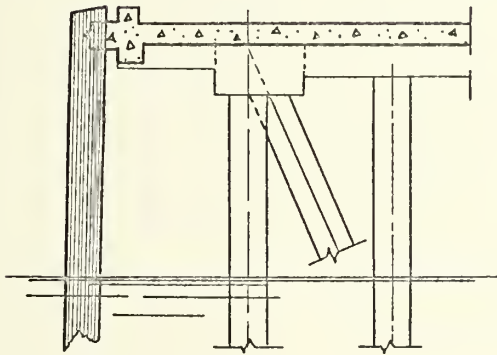

Section
(a) without lower wale

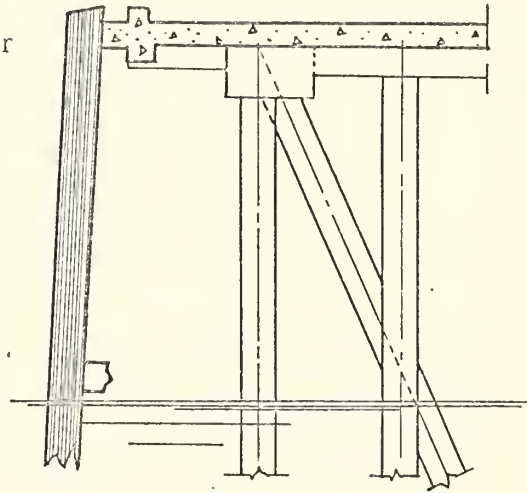

Section
(b) with lower wale

Fig. 6 PILE FENDER SYSTEMS

FENDER PILES

The energy or work absorbed for various types of fender piles may be investigated in the manner shown in Fig. 7.^{17, 18} The energy absorbing capacity of the fender is measured by the total amount of internal strain energy in flexure and shear.

$$E_o = \frac{M_a^2 L}{6 E I} + k \frac{P^2 L}{2 G A} \quad (37)$$

where the first term represents the flexural energy and the second term represents the shear energy. The allowable bending moment, M_a , is given by

$$M_a = \frac{f_{ba} I}{c} \quad (38)$$

and

E_o = internal energy, ft-k

M_a = allowable bending moment, k-ft

P = concentrated lateral load, k

L = length of the fender pile, between load and fixation level, ft

k = dimensionless parameter depending on the type of construction

A = cross sectional area of the fender pile, ft²

I = moment of inertia of the cross section of the fender pile about the plane of bending, ft⁴

E = Young's modulus of elasticity, ksf

G = modulus of rigidity, ksf

f_{ba} = allowable extreme unit fiber stress in bending, ksf

c = distance from neutral axis of pile to extreme fiber, in direction of bending, ft

Cantilever Type

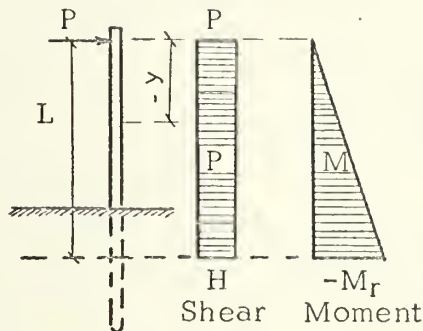

$$H = P$$

$$M = Py$$

$$S = \frac{dM}{dy} = P$$

$$M_r = PL = \text{Resisting Moment Req'd.}$$

Rigid-Wharf Type

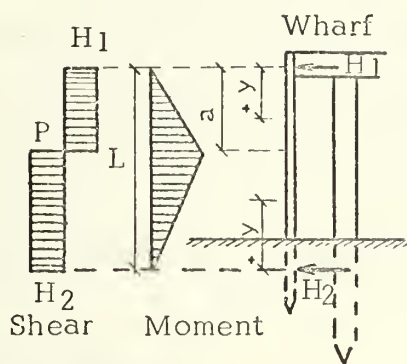

$$H_1 = P - H_2 \quad H_2 = \frac{Pa}{L}$$

$$M = H_1 y \quad y \leq a$$

$$S = \frac{dM}{dy} = H_1$$

$$M = H_2 y \quad y \geq L - a$$

$$S = \frac{dM}{dy} = H_2$$

$$M_r = H_1 a = \text{Resisting Moment Req'd.}$$

Jetty Type

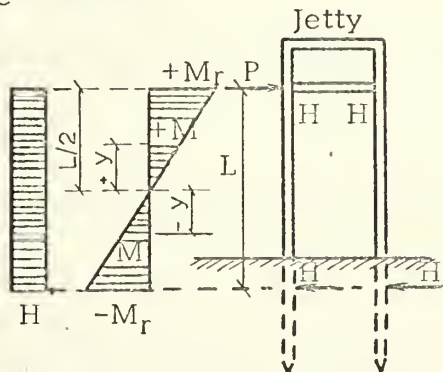

$$H = \frac{P}{2}$$

$$M = \pm Hy$$

$$S = \frac{dM}{dy} = \pm H$$

$$M_r = \pm \frac{PL}{4} = \text{Resisting Moment Req'd.}$$

Fig. 7 CONVENTIONAL TYPES OF FENDER-PILE CONSTRUCTION
 (Shu-T'ien-Li, Waterways and Harbor Div., ASCE,
 Vol. 87, WW3)

The derivation of these equations appears in the reference (3). The values of the parameter k are (see Fig. 7):

Cantilever type $k = 1$

Rigid-wharf type $k = \frac{a(L - a)}{L^2}$

Jetty type $k = 1/4$

HUNG TYPE FENDER SYSTEMS

As was mentioned earlier, these types of fenders are not effective in absorbing high impact energy due to their limited deflection capability. The entire energy absorption capacity is determined by the compressibility of the material. They are primarily effective in preventing abrasion and are widely used for this purpose because of their ease of replacement. Some types of hung fenders are shown in Fig. 8.

RESILIENT FENDER SYSTEMS

Resilient units are of various types. Only the most common will be studied in this paper.

Steel springs - High capacity steel spring units are made of multiple spring coils in a steel housing. The steel springs have a non-corrosive metallic coating (nickel or cadmium) and are also protected by periodic greasing. In some cases it is possible to have the springs entirely out of the water.

Fig. 10a shows a fender unit supported on piles with a steel spring housed in the deck of the wharf. Piles may be either wood or steel, but if the latter is used they should be provided with wood rubbing strips.

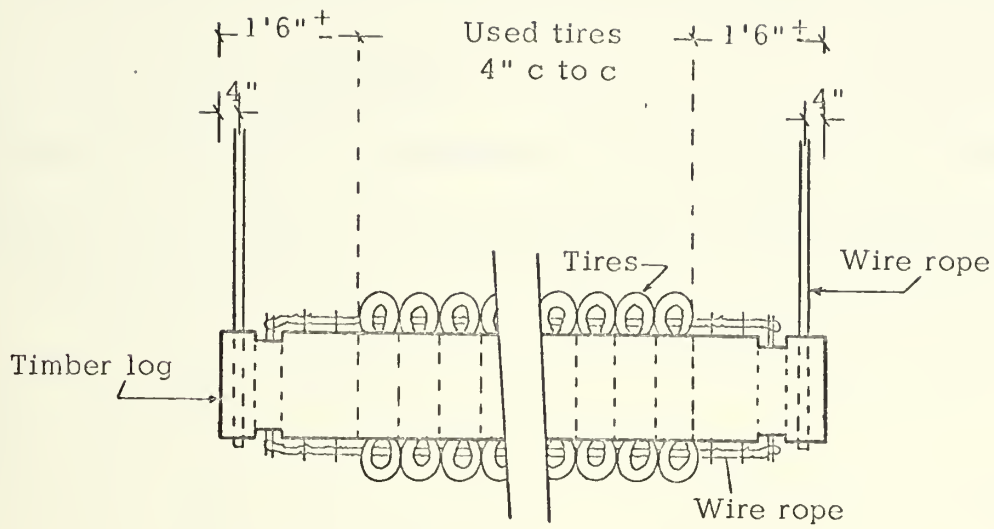

Rubber Tire and Log Fender

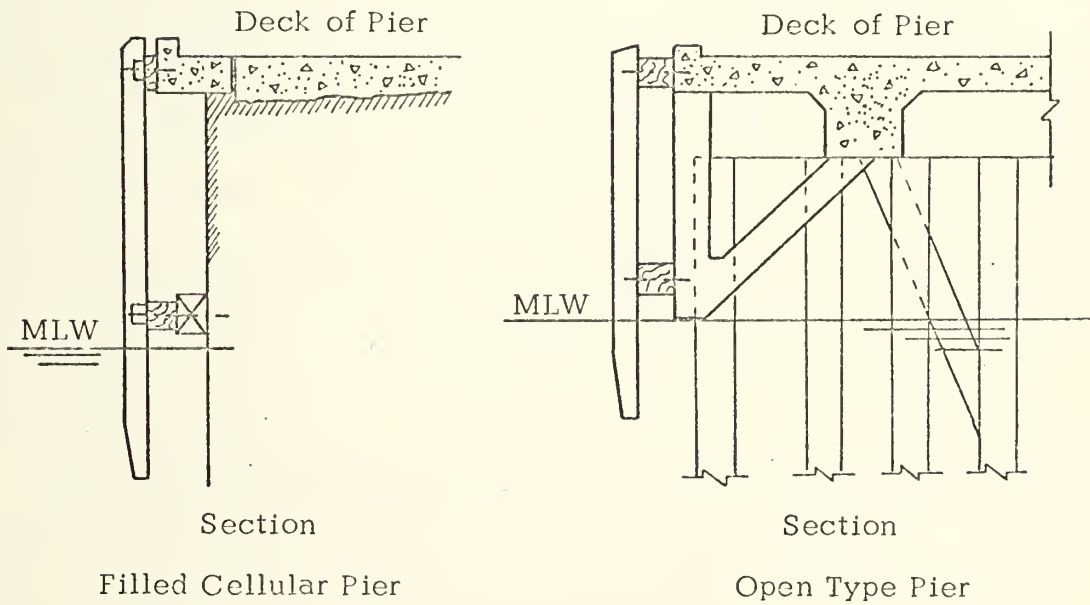

Fig. 8 HUNG FENDER SYSTEMS

The kinetic energy absorbed by a shock-absorber is represented by

$$E_o = \int_0^X f dx \quad (39)$$

in which, f is the variable reaction of the shock-absorber, x the displacement of the surface of contact and X the maximum displacement.

In the case of a spring, it is common to assume that f increases in a linear manner. Therefore $f = k x$.

$$E_o = \int_0^X k x dx \quad (40)$$

$$E_o = 1/2 k x^2$$

where k is the spring factor.

Steel springs have largely been replaced by rubber devices because of the longer life and lower maintenance. Furthermore, rubber can better take the longitudinal forces encountered.

Rubber fender units - A variety of rubber fender units can be found on the market today. Neoprene coating will extend the useful life of rubber for salt water service. Rubber is virtually immune to the action of marine borers and other forms of marine life and does not absorb oil, thus reducing the fire risk.

Cylindrical marine fenders were among the first engineered elastomeric types to be applied for pier and vessel protection. They are highly economical, easily installed, can be used with or without outer wales, and they represent the best practical application for round-face piers or dolphins. Square units have similar application as the

cylindrical or tubular units. The cylindrical and square units do not represent an optimum solution to the fendering needs since their load-deflection curves are of the cubic type (see Fig. 11). It is the opinion of most manufacturers that a 50% deflection represents the limit of efficient energy absorption. At 50% deflection, the internal shaft of the fender is closed, therefore limiting any further deflection to pure compression of the elastometer. At this point, additional energy absorption is accompanied by a more rapid build-up of load.

The load-deflection curves are generally obtained by direct plot of test values. The energy deflection curves are obtained by integrating the load deflection curves. (See Fig. 11.) Hanging cylindrical fenders, as are shown in Fig. 9, are used for protecting concrete-capped and straight-faced vertical piers. They are suspended by chain or wire rope. The eye-bolt supports are recessed to eliminate damage when the fender is deflected to a maximum.

Fig. 10b and Fig. 10c show the application of the square and tubular fenders when the pier is not of the solid-wall type. In Fig. 10c, if the longitudinal wale is longer than about 30 ft, it should be articulated by inserting pin-connected splices which will transmit shear but not moment.¹⁹

Raykin fender buffers consist of a series of connected sandwiches made of steel plates cemented to layers of rubber, as shown in Fig. 12. The impact energy in this type of buffer is absorbed in shear.

Enderbrock²⁰ presents the following energy absorption approach for the Raykin buffer:

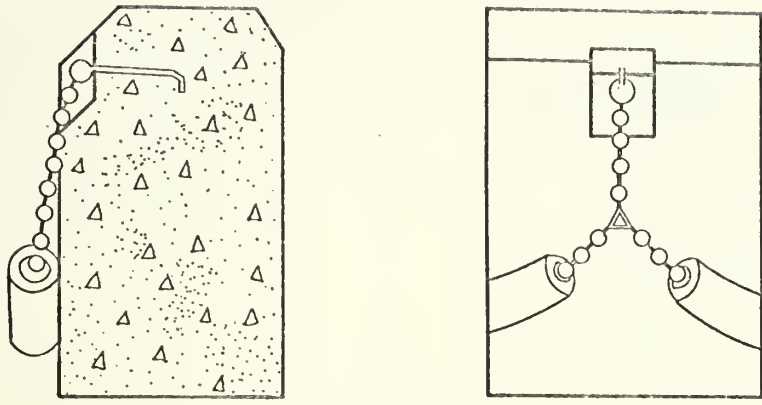

(a)

(b)

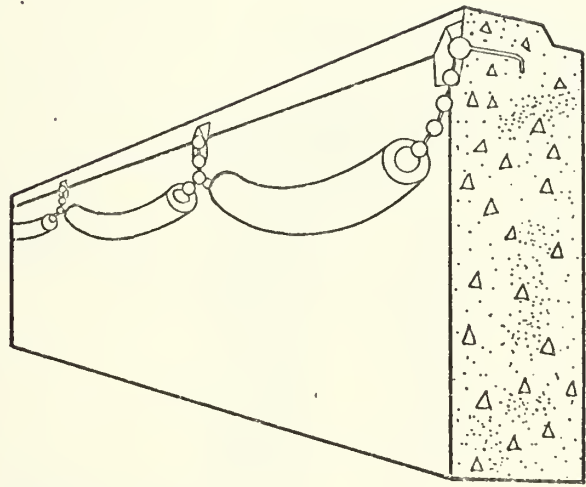

(c)

Fig. 9 CYLINDRICAL RUBBER FENDERS

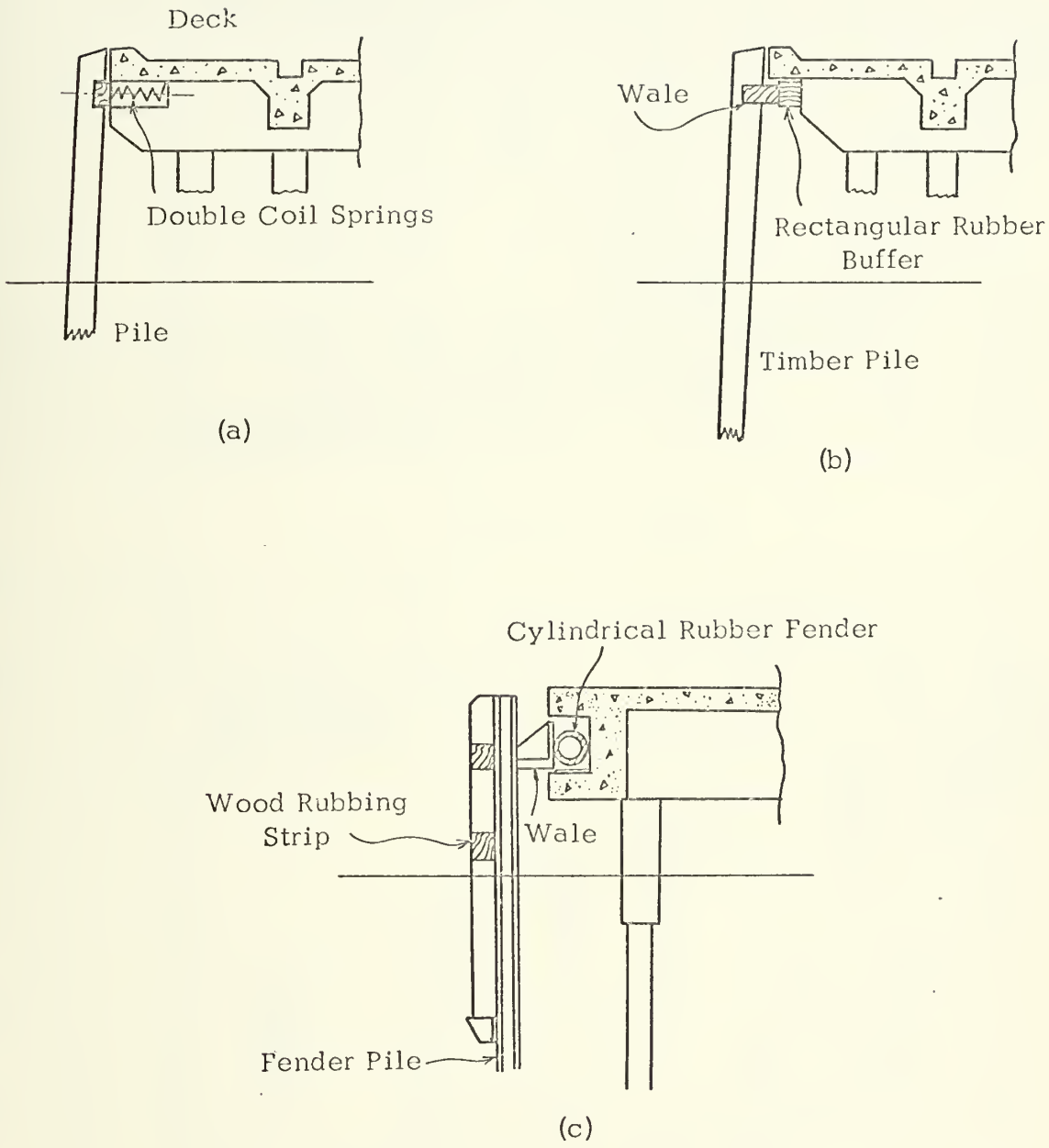

Fig. 10 RESILIENT FENDER SYSTEMS

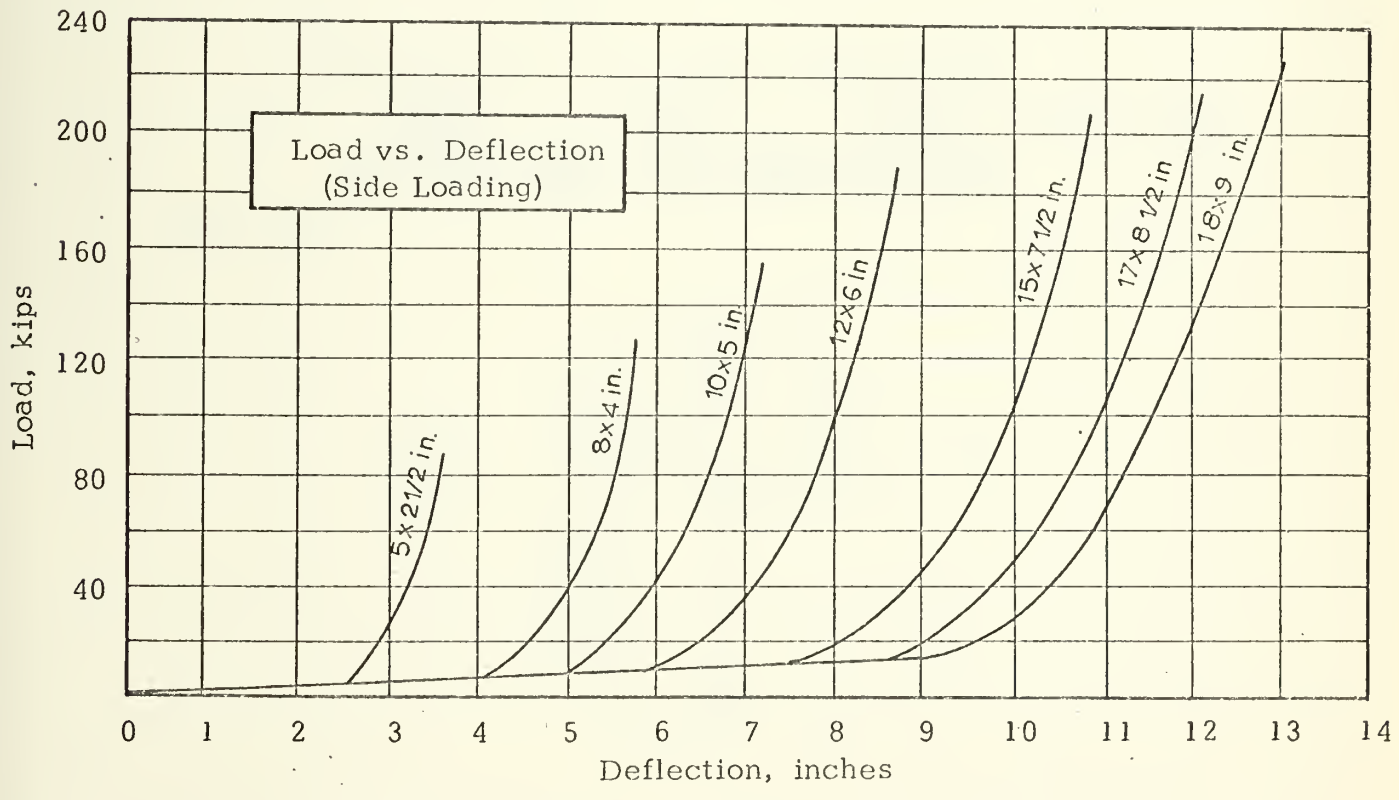
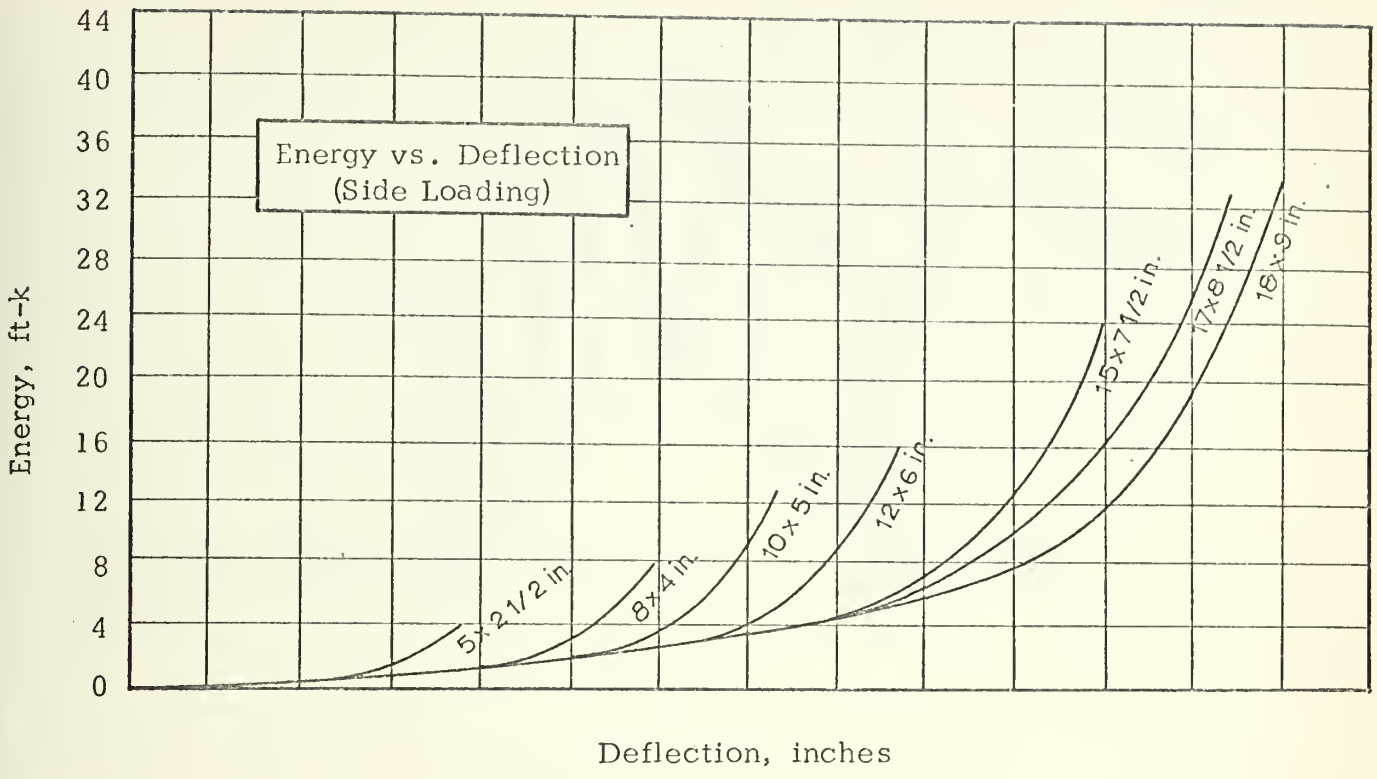
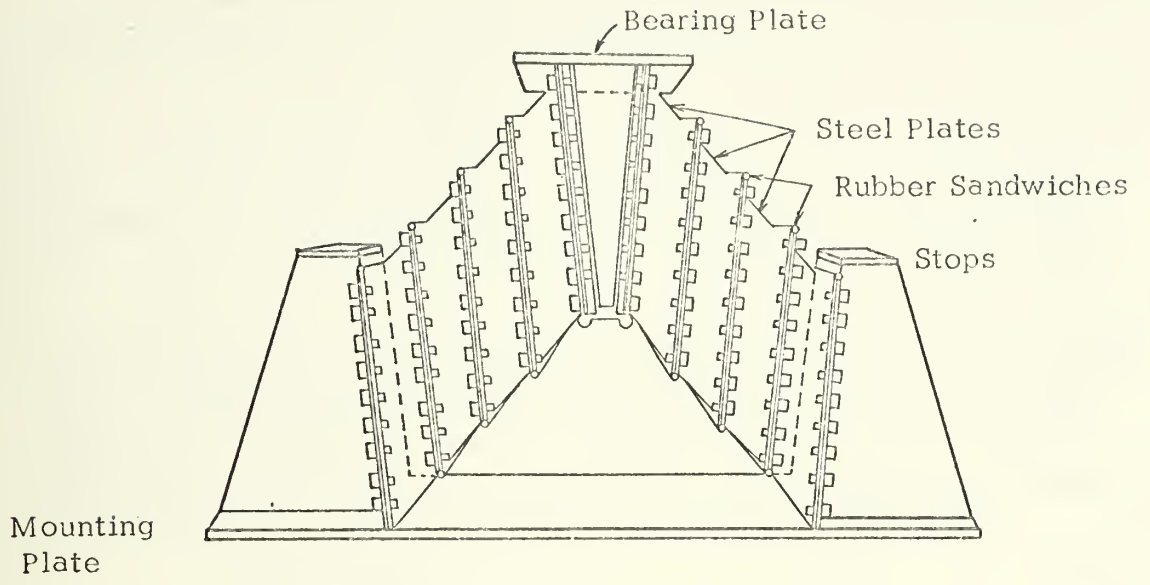
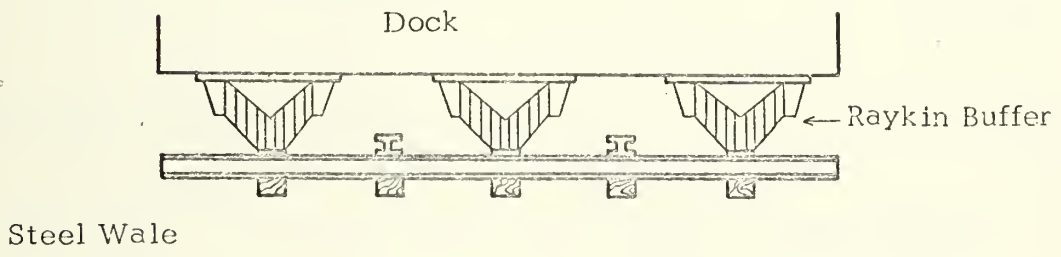

Fig. 11 CYLINDRICAL RUBBER FENDERS (United States Rubber Corporation, Catalog 831, 1958)



Raykin Buffer



Steel Wale

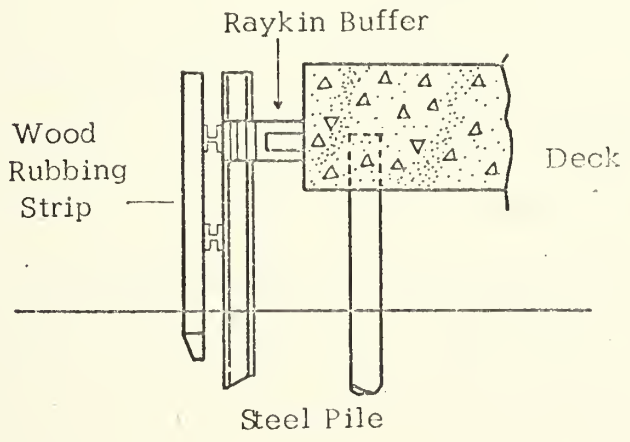

Fig. 12 RESILIENT FENDER SYSTEMS, RAYKIN TYPE

The work done per unit volume of rubber in stressing the material in pure shear up to the shearing limit, S_e , is

$$e = \frac{S_e^2}{2 G} \quad (42)$$

where $G = \frac{E}{2(1+u)} \quad (43)$

The modulus of elasticity, E , may be taken as 150,000 psi; the Poisson's Ratio, u , is assumed equal to 0.5. G then equals 50,000 psi. The shearing yield strength is 0.577 times the tensile yield strength. The minimum tensile strength of rubber fenders, as set down by the ASTM manual on rubber products, is 2500 psi. Using these values the total work absorbed by a Raykin fender is

$$E_o = \frac{S_e^2}{2 G} V \quad (44)$$

$$= \frac{(0.577 \times 2500)^2 V}{2 (50,000) (12)}$$

$$E_o = 1.73 V \quad (45)$$

where E_o = energy absorbed, ft-lb
 V = volume of rubber, in.³ 21

The "Lord Flexible Dock Fender" developed by the Lord Manufacturing Co.²² is shown in Fig. 13. This flexible fender uses the principle of the "buckling column." When a compressive force is applied to a slab of rubber, this results in a fairly rapid buildup in load for a relatively small deflection. When a column of material, in this case rubber, has a height greatly in excess of its cross-sectional dimensions, it becomes very unstable under compressive loads applied along the longitudinal axis of the column. When this condition exists, the column will collapse or buckle. However, taking these two facts into consideration, it is possible to design a column which will meet

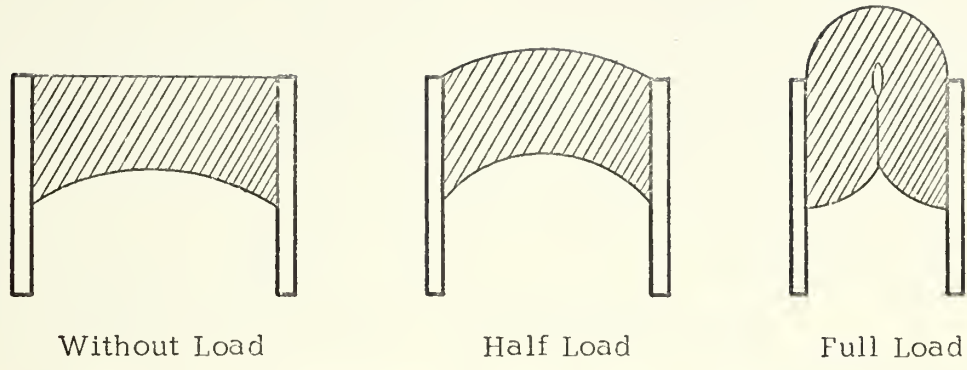

BUCKLING COLUMN TYPE BUFFER

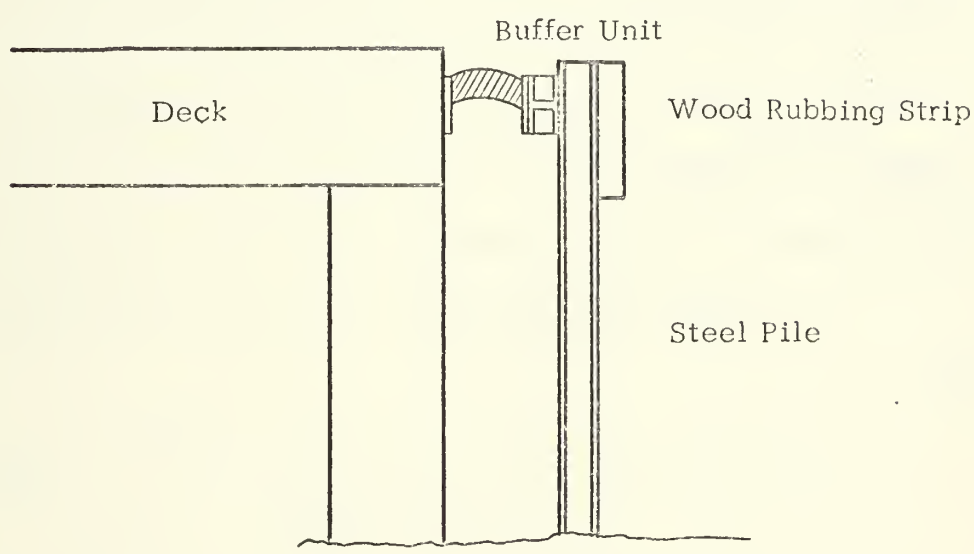

Fig. 13 BUCKLING COLUMN TYPE BUFFER
(Lord Manufacturing Co., Bulletin No. 800)

the criteria mentioned above. Generally speaking, it is desirable to obtain the maximum area under the load deflection curve (see Eq. 39) which results in the best possible energy absorption for any given deflection or load. The "buckling column" is designed to:

- a. Build up a relatively high load for small initial deflection
- b. Collapse at relatively small initial deflection
- c. Maintain a constant force over a range of buckling deflection
- d. Buckle in a pre-selected direction

SUSPENDED OR GRAVITY FENDER SYSTEMS

Suspended fenders are widely used in Europe in open type piers, especially in berthings for tankers. This system employs a heavy fender suspended from the structure. As the ship contacts the fender, the berthing energy is absorbed as potential energy by moving the mass of the fender inward and upward. The absorbed energy is

$$E_o = W h \quad (46)$$

where E_o = energy absorbed by the fender, ft-lb

W = weight of the fender, lb

h = height which is the fender raised, ft

This system can be designed to absorb any amount of energy but is usually massive and requires a complicated suspension system. This system also offers little resistance to longitudinal berthing forces.

Different types of gravity fenders are shown in Figures 14, 15 and 16.

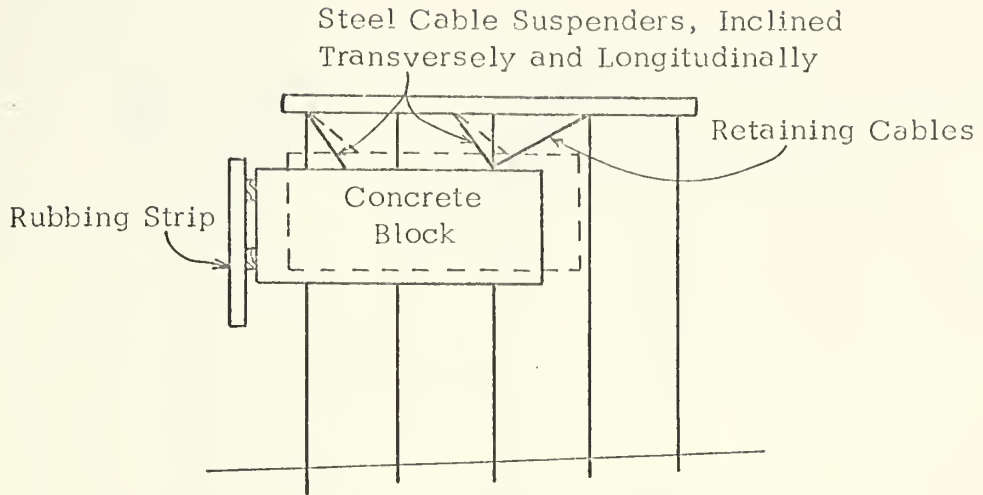

Fig. 14 SUSPENDED-GRAVITY FENDER, CONCRETE-BLOCK TYPE
(Dock and Harbor Authority, January, 1947)

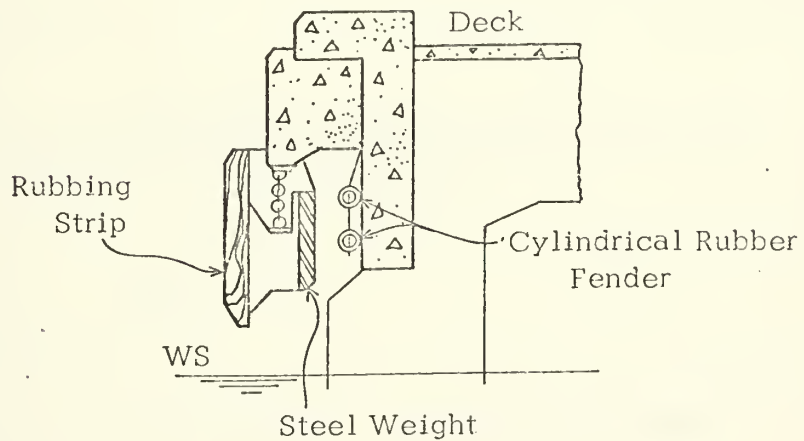
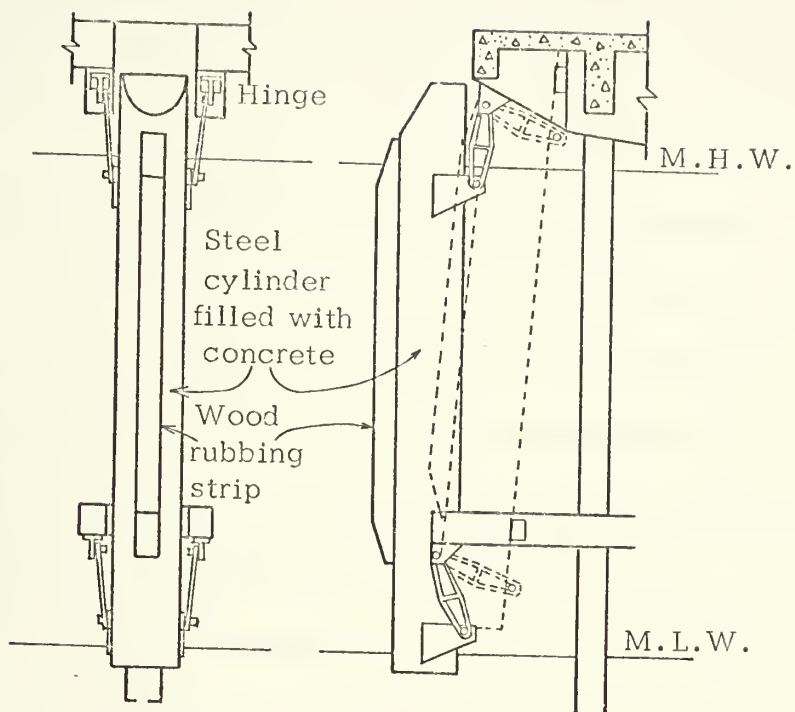
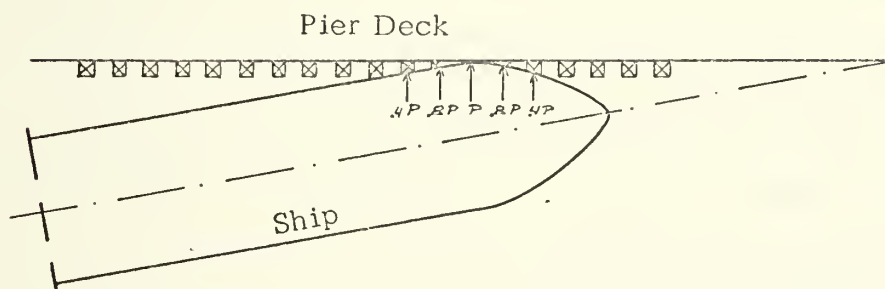

Fig. 15 PENDULAR SHOCK-ABSORBERS (Mantelli patent)



Suspended-Gravity Fender, Tubular Type



Ship Striking Dock with Suspended-Gravity Fender System

Fig. 16 SUSPENDED-GRAVITY FENDER SYSTEM (DESIGN AND CONSTRUCTION OF PORTS AND MARINE STRUCTURES, Alonzo de F. Quinn)

RETRACTABLE FENDER SYSTEM

A retractable fender is an adaptation of the gravity fender developed by Blancato^{23, 24} and is shown in Fig. 17. The fender consists of a frame supported on inclined channels fastened to the platform structure. Two pipes support the fender frame on the inclined channels. Any applied force greater than the weight of the fender plus the frictional force at the pipe support will cause the frame to move inward and upward. The force required to move the frame is a function of its weight, the inclination of the sliding plane and the coefficient of friction of the different members in contact with the sliding movement. In order to avoid initial over-rigidity, the weight of the frame should be light enough to permit its movement to begin under a relatively small acting force. However, after movement of the frame has begun, its resistance to the acting force must be increased. This is accomplished by adding weights which are raised at subsequent intervals as movement of the frame continues. Further graduation of the resistance of the frame to acting forces can be achieved by varying the slope of the inclined plane on which the frame moves.

This type of fender can be designed to absorb a large amount of energy. Since the rate of energy absorbed increases with the retraction, it could be used for berthing of large or small ships.

SEPARATORS OR FLOATING FENDERS

Floating "camels" are devices for preventing collision damage to berthed vessels. They are largely used in berthing large vessels such

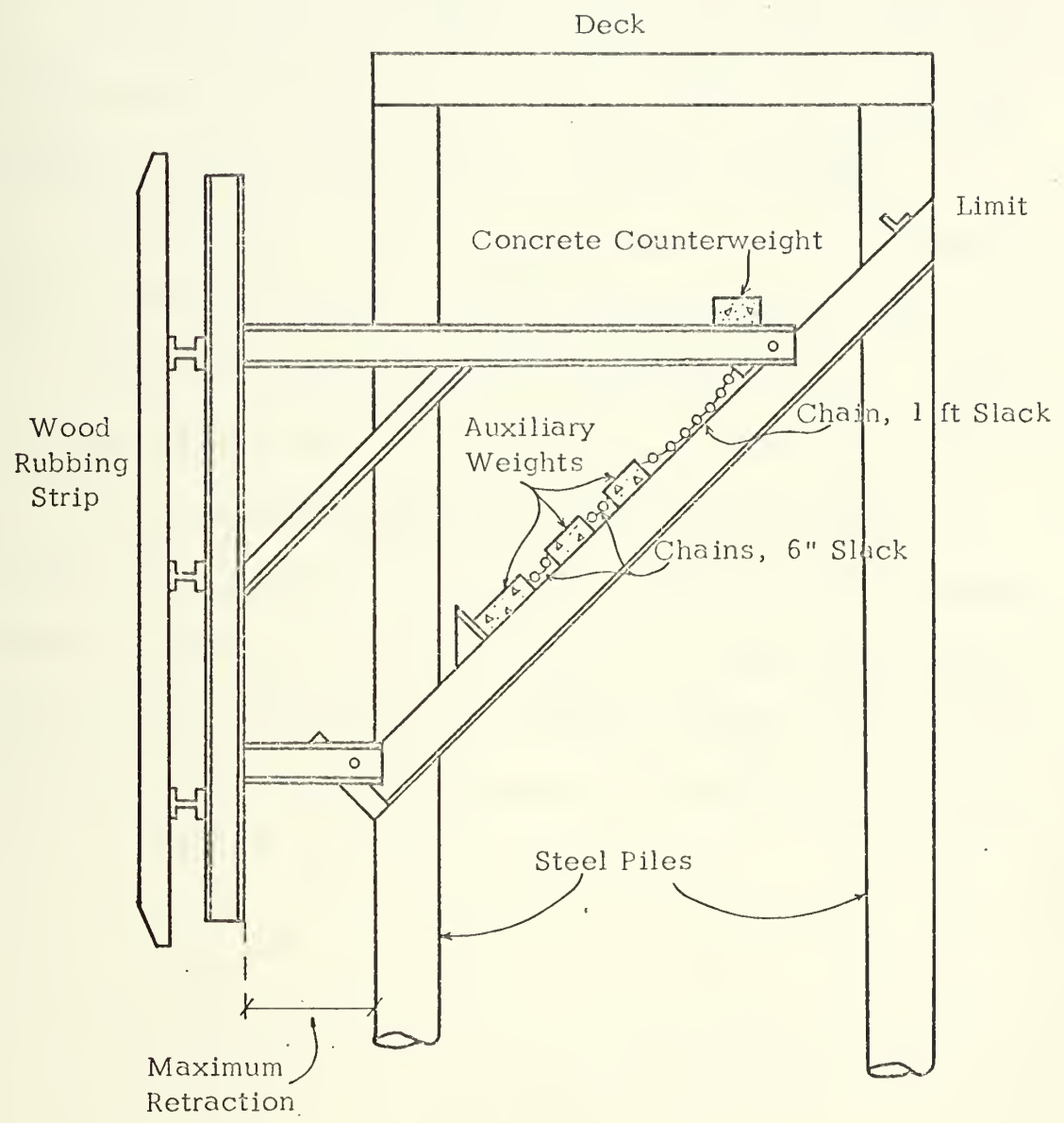

Fig. 17 RETRACTABLE FENDER SYSTEM, BLANCATO TYPE

as supertankers or aircraft carriers because the camel distributes the load along a greater length of the fender system and protects the overhanging projection of the ship.

Log camels may be single or multiple. Single log camels are timber logs of 14 to 36 inches in diameter. Multiple log camels are composed of several timber logs held together by wire rope.

Timber camels consist of several timbers with struts between them and with cross braces, all bolted together to form a crib.

For large ships, spare barges may be used as camels. Fenders and brackets are added which are shaped to the water line contour.

The length of the separator should be adequate to keep the contact pressure between the separator and the hull within allowable limits. The Navy design manual NAVFAC-DM-25 says that for large vessels, hulls will normally have adequate strength to resist a contact pressure between the hull and separator of 10,000 to 15,000 lb per ft.

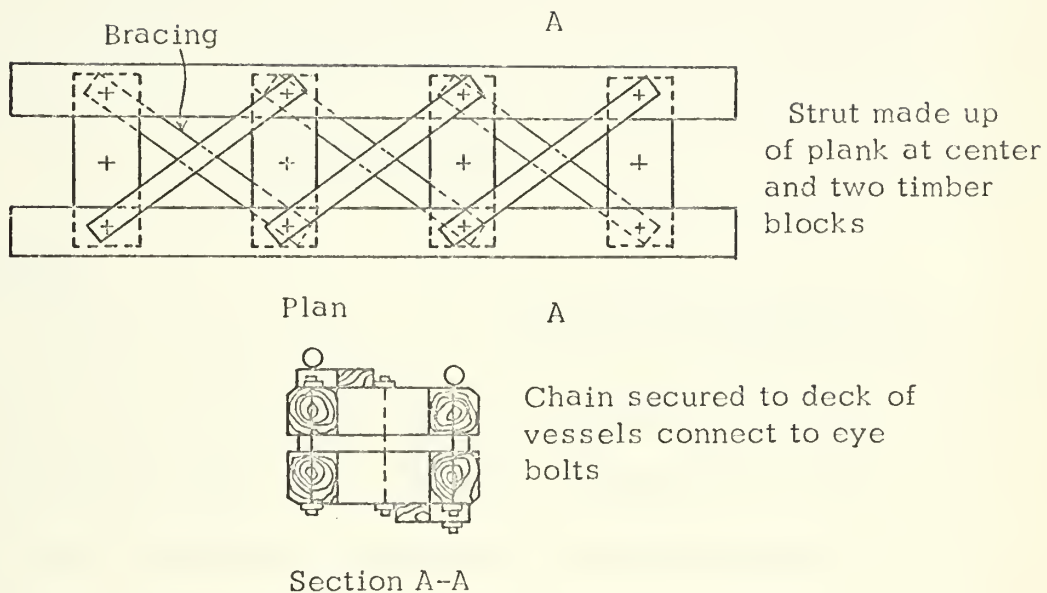

(a) Framed Timber Camel

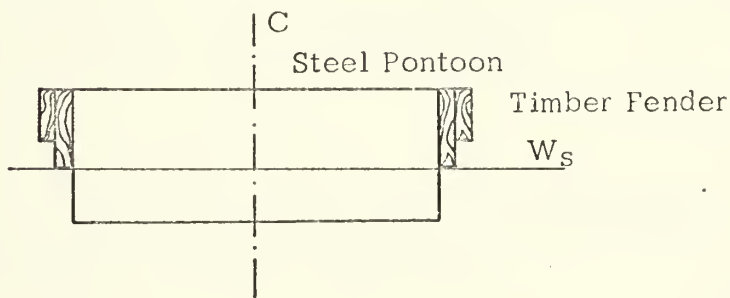

(b) Steel NL-Type Pontoon Camel

Fig. 18 SEPARATORS OR FLOATING FENDERS

CHAPTER IV

DESIGN CRITERIA

DATA EVALUATION

It is not possible to set up one set of conditions or criteria for the determination of the probable berthing or mooring force of vessels that can be used for all fender system designs. Sometimes the data relative to the forces involved are comparatively few and generally not in a form to be directly applicable. On these occasions, the designer should review practical design manuals and should use the criteria of other wharves and docks as a design guide.

Some figures that could be used are the following:

(1) Velocity and Angle of Approach

The Navy design manual NAVFAC DM-26 gives the following estimated figures for NORMAL berthing conditions.²⁵

TYPE OF SHIP	APPROACH VEL. knots	ANGLE APP. degrees
Destroyers and small craft	1.0	20
Vessels of 50,000 tons loaded displacement or over	0.3	10
Other vessels	0.5	10

To get the velocity perpendicular to the pier, the approach velocity must be multiplied by the sine of the angle of approach.

(2) Lateral Load

The facility shall be capable of resisting the following lateral forces.²⁶

<u>Type of Ship</u>	<u>Load Perpendicular to Pier lb per linear ft of facility</u>
Submarines and destroyers	1000
Auxiliaries and cruisers	1500
Battleships and escort carriers	2000
Large carriers	2500

At locations where maximum wind velocities do not exceed 60 mph and the currents are 2 knots or less, the above values may be reduced 20 percent.

(3) Pressure in the Ship's Hull

For large vessels, the hull will normally have adequate strength to resist a contact pressure between the hull and the fender of 10,000 lb per ft. For supertankers, Weis²⁷ gives 6,000 lb per ft as maximum pressure in the hull.

(4) Longitudinal Load

Professor Baker²⁸ proposes that the longitudinal component of the load be assigned a value representing 0.10 to 0.25 of the lateral force.

(5) Kinetic Energy

It is extremely difficult to obtain reliable information about the velocity of approach. The gross kinetic energy can be computed using Eq. 2, when the ship is fully loaded and the velocities given in (1) are used.

When insufficient information is available to evaluate the coefficients C_m , C_e , C_s , and C_c (Eq. 1), a total coefficient C_t is used.

Thus,

$$E = E_0 C_t \quad (47)$$

Vessels lighter than 20,000 tons $C_t = 1.0$

Vessels heavier than 20,000 tons $C_t = 0.5$

SELECTION OF TYPE OF FENDER

The starting point in any design is to determine the relationship between efficiency and cost. As an example, Fig. 19 shows typical load-deflection curves plotted for a steel spring, rubber tubes, solid rubber, rubber-sandwich, and buckling column buffers under compressive loads with equal absorption at 12 in. deflection. At a 12 in. deflection, the hollow-rubber type fender has a very large reaction force over the pier and ship. Therefore, its use in a light construction pier is objectionable. A rubber sandwich or "buckling column" buffers have a low load reaction and are advisable for this type of pier. The cost of these buffers, however, is very large compared with the hollow rubber buffers.

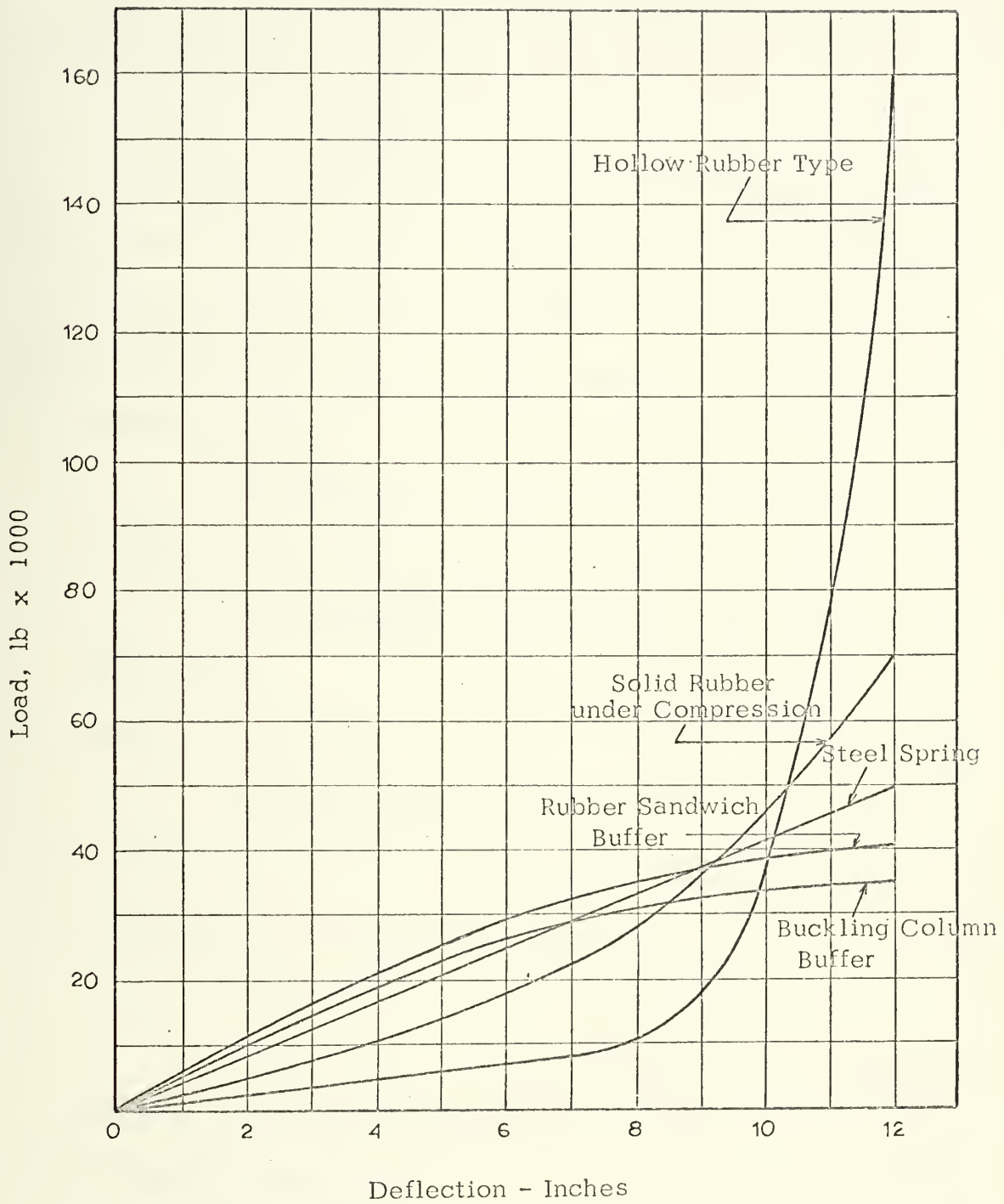

Fig. 19 TYPICAL LOAD-DEFLECTION CURVES FOR DIFFERENT TYPES OF BUFFERS

The U. S. Navy gives the following recommendations for the selection of the fender system:²⁹

(1) Exposure Conditions

In exposed locations or in locations subject to seiche, a resilient type of fender should be used but suspended systems may be considered. In sheltered locations (i. e., normal locations as in berthing basins), generally use a pile, hung or retractable system.

(2) Size of Vessel

(a) Where large vessels are to be accommodated, use a resilient, suspended or retractable system.

(b) Pile and hung systems are the most suitable for small vessels.

(3) Pier Structure Type

(a) Mooring platforms - Consider resilient, suspended or retractable types since the length of the structure available for distribution of berthing loads is limited.

(b) Open pier - Any type is applicable.

(c) Solid pier - These have little resilience. Consider resilient or retractable fenders to minimize damage to the vessel.

(4) Previous Experience

The design and selection of a fender system are not subject to an exact analysis. Consider and evaluate types of systems which have given satisfactory previous service at or near the planned installation.

PART II

ANALYSIS OF A MARINE FENDER SYSTEM UTILIZING
TORSIONAL RESISTANCE

CHAPTER V

TORSIONAL FENDER SYSTEM, PRELIMINARY ANALYSIS

As was mentioned in Chapter III most of the marine fender systems in use today receive their energy-absorption capacity from one or more of the following sources:

Flexural strain

Compressive strain

Shear strain

Torsional strain

Work against mass

From all of the more common types of fenders, the spring type is the only buffer that uses mainly torsional resistance to absorb energy, but direct shear is also present in the spring; however, the energy absorbed by direct shear is less than 2% of the energy absorbed by torsion.

The energy equation for the cylindrical coil spring is

$$E_o = E_t + E_s$$

and the energy as a function of the applied load is

$$E_o = P^2 \frac{4Rn}{Gd^2} (8R^2/d^2 + 1) \quad (48)$$

The energy as a function of the deflection, δ , is

$$E_o = \delta^2 \frac{Gd^2}{16 R n} \left(\frac{d^2}{8R^2 + d^2} \right) \quad (49)$$

The first term of Eq. 49 represents the torsional shear energy, and the second, the direct shear energy. The definition of the terms in the equation is as follows:

P = applied load, lb

d = wire diameter, in.

R = helix mean radius, in.

δ = spring deflection, in.

n = number of coils

G = modulus of rigidity, psi

Steel springs can be designed to absorb practically any amount of energy; however, they require maintenance. The springs are not able to take longitudinal berthing forces, and structural guides must be provided for their protection.

The ability of some materials to absorb energy in torsion is relatively large. It is possible that a better design of a buffer device would eliminate the disadvantages of the spring buffer. An attempt will be made to design another type of buffer that uses mainly torsional resistance to absorb energy.

a. Long piles working in torsion

A long cantilever pile working in torsion as shown in Fig. 20 will be investigated.

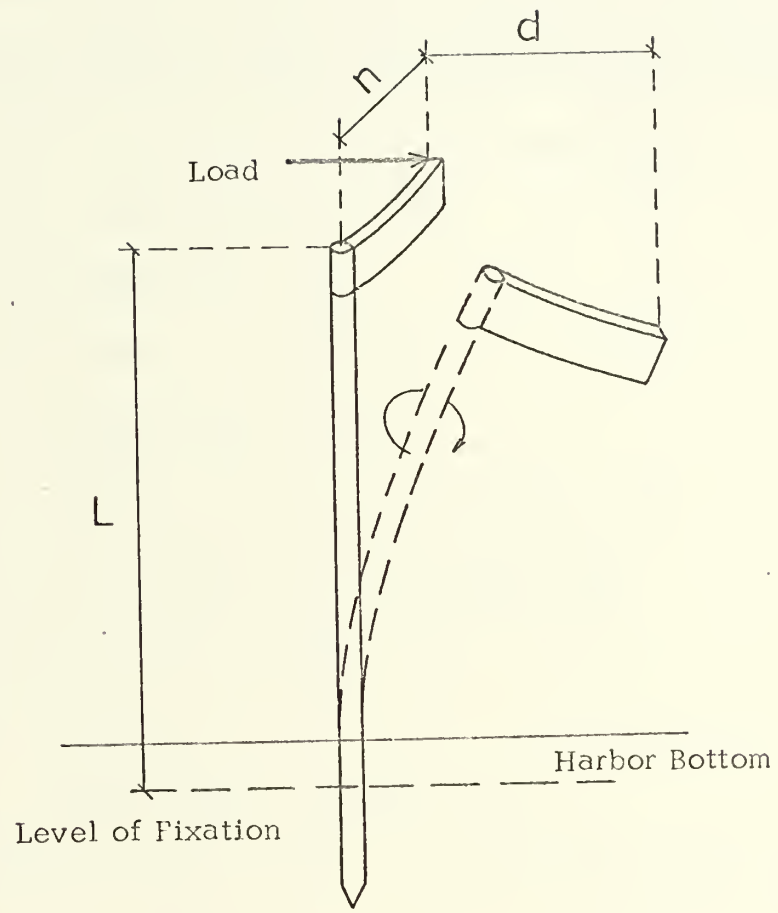

Fig. 20 LONG CANTILEVER PILE WORKING IN TORSION

The total energy absorbed by a cantilever pile is given by

$$E_a = \frac{M^2 L}{6 E I} + \frac{P^2 L}{2 G A} + \frac{T^2 L}{2 G J} \quad (50)$$

where the first term represents the flexural energy, the second term represents the shear energy, and the third term represents the torsional energy. The definition of the terms used in the equation is:

M = resistant moment, lb-in.

P = applied load, lb

T = applied torque, lb-in.

L = length of the pile, in.

A = cross sectional area of the pile, in.²

E = Young's modulus of elasticity, psi

G = modulus of rigidity, psi

I = moment of inertia, in.⁴

J = polar moment of inertia, in.⁴

For long piles the shear energy is only 5% or less of the total energy and so could be disregarded.

Suppose that a cylindrical tube pile is used. Then,

$$M = f_b \frac{I}{R} \quad (51)$$

$$T = f_s \frac{J}{R} \quad (52)$$

$$J = 2 I \quad (53)$$

where f_b = flexural stress, psi

f_s = shear stress, psi

R = external radius, in.

$$\text{and } E_a = \frac{I L}{R^2} \left(\frac{f_b^2}{6 E} + \frac{f_s^2}{G} \right) \quad (54)$$

For A-36 steel, $f_b = 22,000$ psi $E = 29,000$ ksi

$f_s = 14,000$ psi $G = 11,200$ ksi

$$\begin{aligned} E_a &= \frac{I L}{R^2} \left(\frac{22^2}{6 (29,000)} + \frac{14^2}{11,200} \right) \\ &= \frac{I L}{1000 \times R^2} (2.78 + 17.5) \end{aligned}$$

It can be stated that the capacity to absorb energy in torsion is $17.5/2.78 = 6.3$ times the capacity to absorb energy in flexure for this particular type of pile.

For a 12 in. steel pipe, ASA-120, 50 ft long, $R = 6.375$ in. and $I = 641.7$ in.⁴ The energy absorption capacity of the pipe is

$$\begin{aligned} E_a &= \frac{641.7 \times 50 \times 12}{6.375^2 \times 1000} (2.78 + 17.5) \\ &= (26.4 + 166.0) \text{ k-in.} \end{aligned}$$

The maximum load that can be applied, P_{\max} , is governed by the flexural strength.

$$E_b = \frac{P_{\max}}{2} d \quad (55)$$

$$\text{where } d_p = \frac{P_{\max} L^3}{3 E I} \quad (56)$$

$$\text{and } P_{\max} = \sqrt{\frac{26.4 \times 29,000 \times 641.7 \times 6}{(50 \times 12)^3}}$$

$$P_{\max} = 3.70 \quad \text{kips}$$

The maximum deflection of the pile for this load is 14.31 in. If it is desired to use the entire energy-absorption capacity of the pile in torsion, how long should the lever arm, n , be?

$$T = P n \quad (57)$$

$$E_T = \frac{T^2 L}{2 G J} \quad (58)$$

$$n = \sqrt{\frac{2 \times 11,200 \times 2 \times 641.7 \times 166}{3.70^2 \times 50 \times 12}}$$

$$= 762 \quad \text{in.}$$

$$= 63.5 \quad \text{ft}$$

And the additional deflection on the tip of the lever arm due to the rotation is

$$E_T = \frac{P_{\max}}{2} d_T$$

$$166 = \frac{3.70}{2} d_T$$

$$d_T = 89.72 \quad \text{in.}$$

and the total deflection is

$$d = 14.31 + 89.72$$

$$= 104.3 \quad \text{in.}$$

A lever arm of 63 ft and a deflection of 104.3 is impractical; therefore this system is not useful.

b. Torsional device as shown in Fig. 21

This device consists of a short cylinder working in torsion attached to the face of the pier.

$$E_T = 1/2 T \theta \quad (59)$$

$$T = f_s \frac{J}{R} \quad (50)$$

$$J = \frac{\pi R^4}{2} \quad (60)$$

$$\theta = \frac{T L}{G J} \quad (61)$$

$$E_T = \frac{f_s^2}{2 G} \times \frac{J L}{R^2} = \frac{\pi}{4} \frac{f_s^2 R^2 L}{G} \quad (62)$$

In this device the parameters L and G are very important. The value of the length, L , is relatively small. If we use steel, G is very large (11,200,000 psi) and the absorption capacity of this device in torsion is very small.

If we use rubber, G is small (125 psi for rubber 60 durometer). Therefore the energy-absorption capacity is relatively large. Unfortunately, this device is very weak in flexure and will collapse.

c. Torsional rubber device with steel shaft

An improvement of the previously mentioned device is shown in Fig. 22. A steel shaft runs along the center of the rubber with the shaft welded to the support. The rubber is working in torsion and the bending is resisted by the steel shaft.

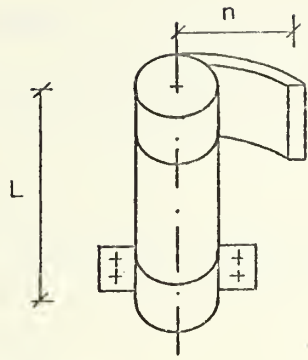

Fig. 21 TORSIONAL RUBBER BUFFER

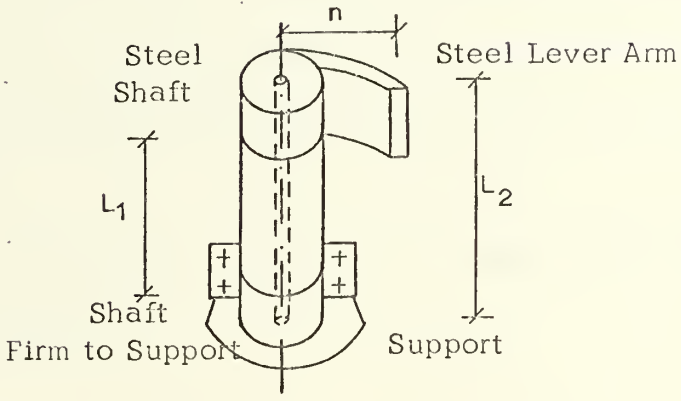

Fig. 22 TORSIONAL RUBBER BUFFER WITH STEEL SHAFT

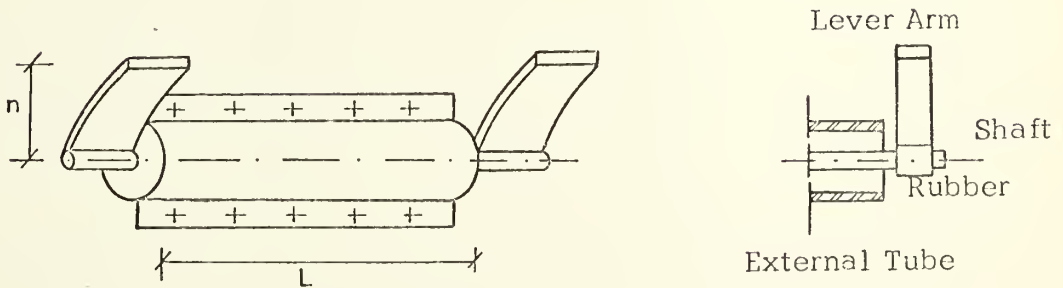

Fig. 23 COAXIAL TUBES IN TORSION

This buffer could work, but the bending moment at the support is very large and not all the rubber is working in torsion. Of the total length of the rubber, L_2 , only the length, L_1 , absorbs energy.

d. Coaxial tubes in torsion

Fig. 23 shows two coaxial tubes with rubber between them. The rubber is bonded to both tubes.

In this device all the rubber is acting in torsion. Modern techniques allow high strength bond between rubber and steel. This leads one to believe that the system would not be too expensive to build.

The principle has been used successfully in absorption of vibration in heavy machines and also as shock absorbers in the automotive industry.³⁰

An analysis of its application as a marine fender will be made in the following chapters.

CHAPTER VI

MATHEMATICAL ANALYSIS OF RUBBER BUFFER IN TORSION

a. Stress-strain relationship

By definition the shear modulus of elasticity, G , is given by the ratio stress/strain. The stress is equal to the load P divided by the area A (see Fig. 24).

For small angles, the strain equals either (a) the tangent of the angle, or (b) the angle in radians. Downie Smith³¹ has said that the latter definition of the strain gives better agreement between theory and practice, therefore

$$\text{Strain} = P / G A \quad \text{radians} \quad (63)$$

By geometry in Fig. 24, $\tan \theta = d/t$, and the deflection, d , is

$$d = t \tan (57.3 P/AG) \quad (64)$$

From these equations it is possible to calculate the strain or the deflection provided the physical dimensions of the rubber, the load, and the modulus of elasticity of the rubber in shear are known.

It is common practice to specify the hardness of rubber in terms of its durometer number (ASTM Specification D 676-59T). It is also possible to correlate the durometer hardness number with the modulus of elasticity in shear, as shown in Fig. 25. The agreement of

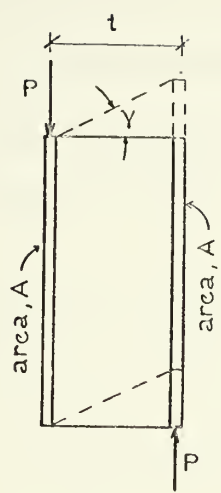

$$G = \frac{\text{Stress}}{\text{Strain}}$$

$$\text{Stress} = P/A$$

By Definition:

$$\text{Strain} = \gamma \text{ (Rad)}$$

By Geometry:

$$\tan \gamma = d/t \quad \therefore \text{For small angles}$$

$$d = t \tan (57.3 P/AG)$$

Fig. 24 SHEAR STRESS-STRAIN RELATIONSHIPS

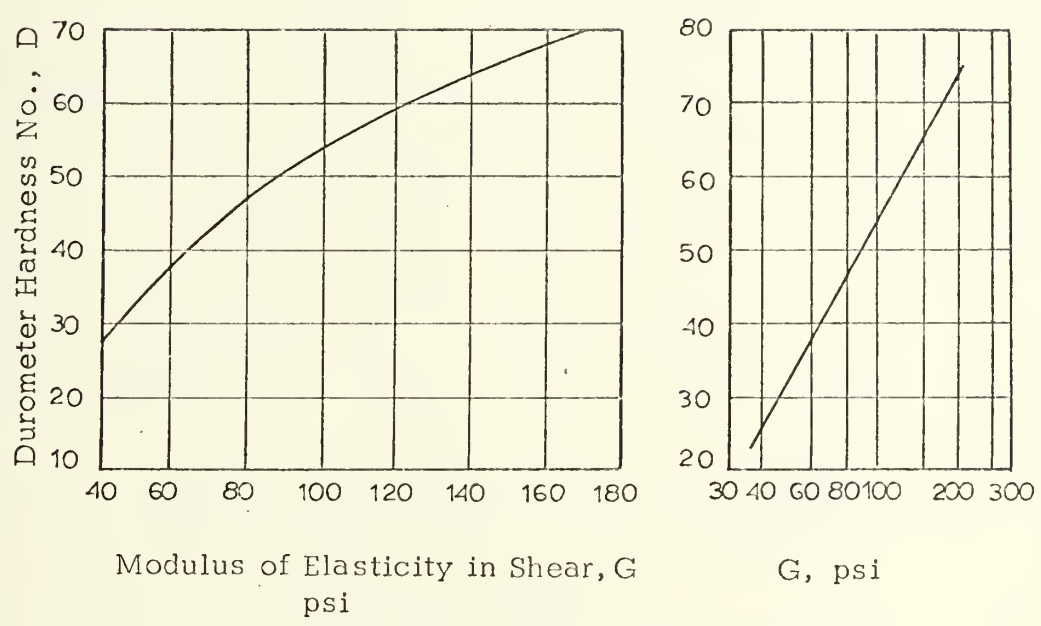

(The equation of the curve is $G = 16.9 e^{0.033D}$)

Fig: 25 RELATION BETWEEN MODULUS OF ELASTICITY OF RUBBER IN SHEAR AND DUROMETER HARDNESS NUMBER

theoretically derived values and experimental data justifies the conclusion that the durometer hardness number and the shear modulus of elasticity are related in the manner shown to quite close limits. The safer way to obtain the value of G , however, is from the rubber manufacturer.

b. Statical analysis of the coaxial tube in torsion

Downie Smith³² presents the following analysis for the coaxial tubes in torsion (see Fig. 26).

$$\text{Torque} \quad T = 2 \pi r^2 L f_s \quad (65)$$

$$\text{Also, approximately} \quad r d\theta/dr = \tan \gamma \quad (66)$$

$$\text{and} \quad \gamma = f_s/G$$

$$\gamma = T/2 \pi L G r^2$$

$$d\theta = (1/r) \tan (T/2 \pi L G r^2) dr$$

For a given torque on a given sample, $T/2\pi LG = \text{const} = a$

$$\int_0^{\theta_2} d\theta = \int_{R_1}^{R_2} \frac{1}{r} \tan \frac{a}{r^2} dr \quad (67)$$

$$\text{Let } a/r^2 = z \quad dz = -2ar^{-3} dr$$

$$\text{and } r = (a/z)^{1/2} \quad dr = -a^{1/2} dz/2 z^{3/2}$$

$$\begin{aligned} \theta_2 &= - \int_{R_1}^{R_2} \left(\frac{z}{a}\right)^{1/2} \tan z \left(\frac{a^{1/2}}{2 z^{3/2}}\right) dz \\ &= - 1/2 \int_{R_1}^{R_2} \frac{\tan z}{z} dz \end{aligned}$$

Where $z^2 < \pi^2/4$ the solution of this equation is

$$\theta_2 = - 1/2 \left[z + \frac{z^3}{9} + \frac{2}{75} z^5 + \frac{17}{2205} z^7 + \dots \right]_{R_1}^{R_2}$$

See Dwight's Table of Integrals, No. 481.2.

$$\begin{aligned}\theta_2 &= -\frac{a}{2} \left[\left(\frac{1}{R^2_2} - \frac{1}{R^2_1} \right) + \frac{a^2}{9} \left(\frac{1}{R^6_2} - \frac{1}{R^6_1} \right) + \dots \right] \\ &= \frac{T}{4\pi LG} \left[\left(\frac{1}{R^2_1} - \frac{1}{R^2_2} \right) + \frac{1}{9} \left(\frac{T}{2\pi LG} \right)^2 \left(\frac{1}{R^6_1} - \frac{1}{R^6_2} \right) + \dots \right] \quad (68)\end{aligned}$$

The solution given in Eq. (68) is based on the assumption that $a/r^2 < \pi/2$, or $\gamma < \pi/2$, which is ordinarily the case.

Seely³³ presents a similar solution for a rubber spring. However, Seely assumed that the deflection is small and G is constant. Therefore Eq. 66 is now

$$r \, d\theta/dr = \gamma \quad (69)$$

$$\text{and} \quad \theta_2 = \frac{T}{4\pi LG} \left(\frac{1}{R^2_1} - \frac{1}{R^2_2} \right) \quad (70)$$

Thus the equation for small deflections is merely the first term of the equation for large deflections.

c. Rubber buffer, dynamic solution

Refer to Fig. 27, a ship of mass M , impact the buffer with a velocity perpendicular to the pier, V_s .

- a. Assume Torque = $k \theta$, where $k = \text{const.}$
- b. Assume no friction.

1. Kinetic energy (ship, M + buffer rod, m)

$$\begin{aligned}T_k &= 1/2 M V^2 + 1/2 I \dot{\theta}^2 \\ T_k &= 1/2 M (n \sin(\beta + \theta) \dot{\theta})^2 + 1/2 I \dot{\theta}^2 \quad (71)\end{aligned}$$

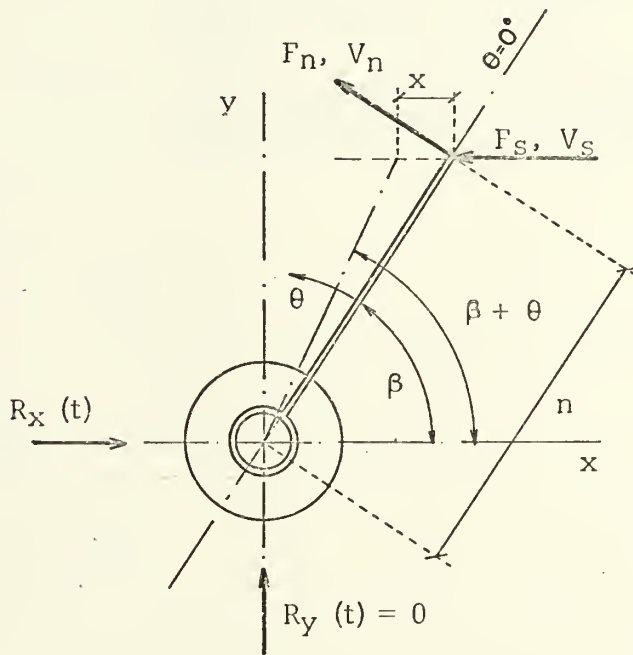
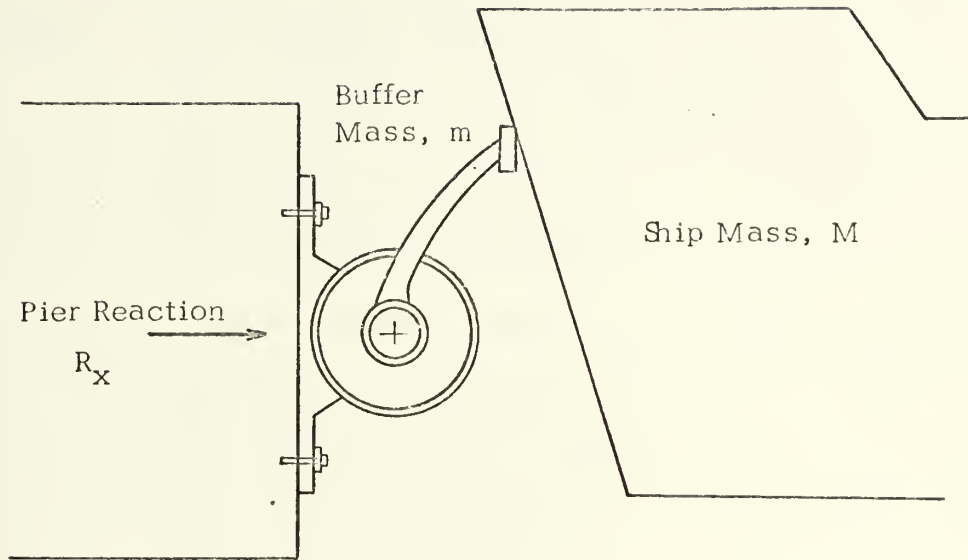

Fig. 27 SHIP STRIKING THE BUFFER

Potential energy (in rubber buffer)

$$V_p = 1/2 k \theta^2 \quad (72)$$

- where
- T_k = kinetic energy, ft-lb
 - V_p = potential energy, ft-lb
 - M = mass of the ship, lb
 - n = length of the lever arm, ft
 - I = moment of inertia of the rod, ft⁴
 - k = spring constant, ft-lb
 - β = initial angle of the rod
 - θ = angle of rotation
 - $\dot{\theta}$ = angular velocity, first derivative of θ with respect to the time, rad/sec
 - $\ddot{\theta}$ = angular acceleration, second derivative of θ with respect to the time, rad/sec²

Lagrangian

$$L = T_k - V_p$$

$$L = (M/2)n^2 \sin^2(\beta + \theta) \dot{\theta}^2 + 1/2 I \dot{\theta}^2 - 1/2 k \theta^2 \quad (73)$$

Euler-Lagrange equation (only one variable, $\theta = \theta(t)$)

$$\frac{d}{dt} \frac{\partial L}{\partial \dot{\theta}} - \frac{\partial L}{\partial \theta} = 0 \quad (74)$$

From (73)

$$\frac{\partial L}{\partial \dot{\theta}} = M n^2 \sin(\beta + \theta) \cos(\beta + \theta) \dot{\theta} - k \theta$$

and

$$\frac{d}{dt} \left(\frac{\partial L}{\partial \dot{\theta}} \right) = (Mn^2 \sin^2(\beta + \theta) + I) \ddot{\theta} + 2Mn^2 \sin(\beta + \theta) \cos(\beta + \theta) \dot{\theta}^2$$

From (74)

$$(Mn^2 \sin^2(\beta + \theta) + 1)\ddot{\theta} + Mn^2 \sin(\beta + \theta) \cos(\beta + \theta)\dot{\theta}^2 + k\theta = 0 \quad (75)$$

but
$$I_{\text{rod}} = \frac{m n^2}{3}$$

and $M n^2 \sin^2(\beta + \theta) \gg \frac{m n^2}{3}$. because the mass of the rod, m , is very small compared with the mass of the ship, M ; therefore

$$Mn^2 \sin^2(\beta + \theta)\ddot{\theta} + Mn^2 \sin(\beta + \theta) \cos(\beta + \theta)\dot{\theta}^2 + k\theta = 0$$

or

$$\ddot{\theta} + \cotan(\beta + \theta)\dot{\theta}^2 + w\theta / \sin^2(\beta + \theta) = 0 \quad (76)$$

where
$$w = \frac{k}{Mn^2} \quad (77)$$

2. Solving for the contact force at the buffer rod tip

$$F_s = -M\ddot{x} \quad (78)$$

but $x = n(\cos \beta - \cos(\beta + \theta))$

$$\dot{x} = n \sin(\beta + \theta)\dot{\theta}$$

$$\ddot{x} = n \cos(\beta + \theta)\dot{\theta}^2 + n \sin(\beta + \theta)\ddot{\theta}$$

where x = deflection or retraction of the buffer, ft

\dot{x} = linear velocity of the ship, first derivative of x with respect to the time, ft/sec

\ddot{x} = linear acceleration of the ship, second derivative of x with respect to the time, ft/sec²

and from Eq. (78)

$$F_s = -Mn(\cos(\beta + \theta)\dot{\theta}^2 + \sin(\beta + \theta)\ddot{\theta}) \quad (79)$$

The summation of the horizontal forces in the system should equal 0.

$$F_s + R_x = 0$$

$$R_x = -F_s$$

and
$$R_x = M n (\cos (\beta + \theta) \dot{\theta}^2 + \sin (\beta + \theta) \ddot{\theta}) \quad (80)$$

3. Boundary conditions

(a) At $t = 0$, $\theta = 0$, and $\dot{\theta} = \frac{V}{n \sin \beta}$

(b) At $t = t_{\max}$, $\theta = \theta_{\max}$, and $\dot{\theta} = 0$

4. Value of parameter k

The torque, T, is

$$T = k \theta$$

From Eq. 68, for first degree of approximation

$$k = 4 \pi L G \left(\frac{R_1^2 R_2^2}{R_2^2 - R_1^2} \right) \quad (81)$$

5. Solution of Eq. (76)

$$\ddot{\theta} + \cotan (\beta + \theta) \dot{\theta}^2 + w \theta / \sin^2 (\beta + \theta) = 0 \quad (76)$$

The solution of this non-linear differential equation requires a numerical solution using a computer program. In general, the approach velocity of the ship is small (0.3 to 1 fps); therefore, the time required for the buffer to stop the ship is relatively large (as will be proven in the following chapter). If the time is large, a static solution is adequate in the buffer problem.

One method of solution of this equation is as follows:

$$\ddot{\theta} + \cotan(\beta + \theta) \dot{\theta} + \theta w/\sin^2(\beta + \theta) = 0 \quad (76)$$

Let $\dot{\theta} = \gamma$ (a)

and Eq. 76 $\dot{\gamma} = -\cotan(\beta + \theta) \gamma^2 - \theta w/\sin^2(\beta + \theta)$ (b)

These two simultaneous differential equations can be solved using the RUNGE-KUTTA Method of the solution of non-linear, second order, differential equations.^{34, 35}

$$\dot{\theta} = f_1(t, \theta, \gamma)$$

$$\dot{\gamma} = f_2(t, \theta, \gamma)$$

and result in the iteration equations,

$$\theta_{i+1} = \theta_i + 1/6(D_1 + 2 D_2 + 2 D_3 + D_4)$$

$$\gamma_{i+1} = \gamma_i + 1/6(C_1 + 2 C_2 + 2C_3 + C_4)$$

which are always performed alternately and the D's and C's are calculated from,

$$D_1 = f_1(t_i, \theta_i, \gamma_i) Z$$

$$C_1 = f_2(t_i, \theta_i, \gamma_i) Z$$

$$D_2 = f_1(t_i + 1/2 Z, \theta_i + 1/2 D_1, \gamma_i + 1/2 C_1) Z$$

$$C_2 = f_2(t_i + 1/2 Z, \theta_i + 1/2 D_1, \gamma_i + 1/2 C_1) Z$$

$$D_3 = f_1(t_i + 1/2 Z, \theta_i + 1/2 D_2, \gamma_i + 1/2 C_2) Z$$

$$C_3 = f_2(t_i + 1/2 Z, \theta_i + 1/2 D_2, \gamma_i + 1/2 C_2) Z$$

$$D_4 = f_1(t_i + Z, \theta_i + D_3, \gamma_i + C_3) Z$$

$$C_4 = f_2(t_i + Z, \theta_i + D_3, \gamma_i + C_3) Z$$

which are calculated in that order, and $Z = (t_{\max} - t_0)/N$, in which N is the number of iterations.

Writing the coefficient equations for Eq. (76),

$$f_1(t, \theta, \gamma) = \gamma$$

$$f_2(t, \theta, \gamma) = -\cotan(\beta + \theta) \gamma^2 - \theta w / \sin^2(\beta + \theta)$$

$$D_1 = Z \gamma_i$$

$$C_1 = -Z (\cotan(\beta + \theta_i) \gamma_i^2 + w \theta_i / \sin^2(\beta + \theta_i))$$

$$D_2 = Z (\gamma_i + C_1/2)$$

$$C_2 = -Z (\cotan(\beta + \theta_i + D_1/2) \times (\gamma_i + C_1/2)^2 + w(\theta_i + D_1/2) / \sin^2(\beta + \theta_i + D_1/2))$$

$$D_3 = Z (\gamma_i + C_2/2)$$

$$C_3 = -Z (\cotan(\beta + \theta_i + D_2/2) (\gamma_i + C_2/2)^2 + W(\theta_i + D_2/2) / \sin^2(\beta + \theta_i + D_2/2))$$

$$D_4 = Z (\gamma_i + C_3)$$

$$C_4 = -Z (\cotan(\beta + \theta_i + D_3) (\gamma_i + C_3)^2 + w(\theta_i + D_3) / \sin^2(\beta + \theta_i + D_3))$$

Using the boundary conditions,

$$t_i = 0, \quad \theta_i = 0, \quad \dot{\theta}_i = \gamma_i = \frac{V_s}{n \sin \beta}$$

and the iteration equations,

$$\theta_{i+1} = \theta_i + 1/6 (D_1 + 2D_2 + 2D_3 + D_4) \quad (82)$$

$$\gamma_{i+1} = \gamma_i + 1/6 (C_1 + 2C_2 + 2C_3 + C_4) \quad (83)$$

A computer program written for solving these equations follows.

```

C RUNGE KUTTA METHOD
C SMAS = SHIP MASS LB SEC SQ./FT
C SV = SHIP VELOCITY FPS
C BK = BUFFER SPRING CONSTANT LB FT
C BN = LEVER ARM LENGTH FT
C BETA = INITIAL ANGLE OF LEVER ARM DEGREES
1 READ (5,10) SMAS, BK, BN, SV, BETA
10 FORMAT ( 5F15.3 )
100 FORMAT(66H          BETA    TIME    ANGLE ANG.VEL  DEFLEC REACTIO
3N    ENERGY)
110 FORMAT( 110, F6.1, 4F8.3, 2F9.1)
XBET = BETA/57.3
A = SV/(BN*SIN(XBET))
H = BK / ((BN**2.0)*SMAS )
TETA = 0.0
TIME = 0.0
ENER = 0.0
XDEL = 0.0
XRX = 0.0
W = 0.05
I = 0
WRITE ( 6,100 )
40 I = I + 1
F11 = XBET + TETA
D1 = A*W
C1 = -W*(COTAN(F11)*(A**2.0) + H*TETA/((SIN(F11))**2.0))
F12 = XBET + TETA + D1/2.0
D2 = (A + C1/2.0)*W
C2 = -W*(COTAN(F12)*((ABS(A+C1/2.0))**2.0) + H*(TETA+D1/2.0)/((SI
1(F12))**2.0))
F13 = XBET + TETA + D2/2.0
D3 = (A + C2/2.0)*W
C3 = -W*(COTAN(F13)*((ABS(A+C2/2.0))**2.0) + H*(TETA+D2/2.0)/((SI
2(F13))**2.0))
F14 = XBET + TETA + D3
D4 = (A + C3)*W
C4 = -W*(COTAN(F14)*((ABS(A+C3))**2.0) + H*(TETA+D3)/((SIN(F14))
32.0))
TETA = TETA + ((D1 +2.0*D2 +2.0*D3 +D4)/6.0)
A = A + ((C1 +2.0*C2 + 2.0*C3 + C4)/6.0)
IF (A) 60, 50, 50
50 TIME = TIME + W
GTET = TETA * 57.3
GA = A * 57.3
FI = XBET + TETA
ACE = -(A**2.0)*COTAN(FI) - H*TETA/((SIN(FI))**2.0)
DELT = BN*(COS(XBET)-COS(FI))*12.0
RX =-SMAS*BN*((A**2.0)*COS(FI) + ACE*SIN(FI))
ENER = ENER + ((RX+XRX)*(DELT-XDEL)/(2.0*12.0))
WRITE (6,110 ) I, BETA, TIME, GTET, GA, DELT, RX, ENER
XRX = RX
XDEL = DELT
GO TO 40
60 GO TO 1
999 CALL EXIT
END

```

CHAPTER VII

TORSIONAL RUBBER BUFFER DESIGN

MATERIALS

Elastometer. Most of the marine buffer manufacturers use natural rubber for elastometers. Therefore, using their experience, natural rubber will be used. Based on long-term performance, natural rubber has proven highly superior to other elastometers because of its low cost, high strength, good weatherability, excellent bondability, tear and abrasion resistance and low set. Although many synthetic materials have been highly recommended for weathering resistance, the improvements have been made at the sacrifice of other characteristics.

With reference to the key chart for selection of the elastometer (ASTM STANDARD-D-735) shown in Fig. 28, the natural rubber used in the coaxial spring should conform to the following specification:

R - (625 or 525) - A1 - C - k1 - R

		<u>Method of Test</u>
where	R = compound of natural rubber	not required
	6/5 - durometer hardness	ASTM-D-676
	2 5 - tensile strength	ASTM-D-412
	A1 - change in tensile strength due to aging	D-573
	C - weather resistance	D-1171



KEY TO ELASTOMER COMPOUNDS FOR

ASTM Designation: D 735; S

Compounds for tires, inner tubes, sponge rubber, hard rubber, belts, hoses

Prepared by SAE - ASTM TECHNICAL COMMITTEE

Issued, May, 1951; Revised, November, 1952

These specifications are subject to change

EXAMPLES

R - 615 B, C, FI, D, etc.

SC - 615 B, C, FI, D, etc.

TYPES

TYPE R
TABLE I

For applications where specific resistance to the action of petroleum-base fluids is not required.

R - Compounds of natural rubber, synthetic rubber, and reclaimed, alone or combinations thereof.

↓
TYPE S

TABLES II, III, IV

For applications where specific resistance to the action of petroleum-base fluids is required.

S - Compounds of synthetic rubber or combinations thereof, which have the following resistance to swelling in low aniline point hydrocarbon fluids:

SA - Very low volume swell.

SB - Low volume swell.

SC - Medium volume swell.

↓
TYPE T

TABLES V and VI

For applications where specific resistance to the effects of prolonged exposure to abnormal temperatures or compounded petroleum oils, or both, is required.

T - Compounds of synthetic rubber or rubber-like materials which have the following resistances:

TA - Maximum resistance to heat and cold.

TB - Outstanding resistance to heat and oil.

SOLID GRADES RUBBER

(615)

DUROMETER HARDNESS

(ASTM Method D 676)

3 - 30 ± 5

4 - 40 ± 5

5 - 50 ± 5

6 - 60 ± 5

7 - 70 ± 5

8 - 80 ± 5

9 - 90 ± 5

TENSILE STRENGTH

(ASTM Method D 676)

min./sq. in.

05 -

10 -

15 -

20 -

25 -

30 -

35 -

THIS KEY IS TO BE USED ONLY IN REFERENCE AND TO ILLUSTRATE TYPES OF THE DETAILED SPECIFICATIONS.

Additional information will be added to this key as it becomes available.

FOR DETAILED REQUIREMENTS SEE SPECIFICATIONS ASTM Designation: D 735, D 736, D 737, D 738, D 739, D 740, D 741, D 742, D 743, D 744, D 745, D 746, D 747, D 748, D 749, D 750, D 751, D 752, D 753, D 754, D 755, D 756, D 757, D 758, D 759, D 760, D 761, D 762, D 763, D 764, D 765, D 766, D 767, D 768, D 769, D 770, D 771, D 772, D 773, D 774, D 775, D 776, D 777, D 778, D 779, D 780, D 781, D 782, D 783, D 784, D 785, D 786, D 787, D 788, D 789, D 790, D 791, D 792, D 793, D 794, D 795, D 796, D 797, D 798, D 799, D 800. COPIES OF THIS KEY CHART, MAY BE OBTAINED FROM THE AMERICAN SOCIETY FOR TESTING MATERIALS, 1195 AVENUE OF THE AMERICAS, NEW YORK, N. Y.

UTOMOTIVE APPLICATIONS

Standard: J14

ots, and insulated wire and cable are not included.

ON AUTOMOTIVE RUBBER

54, 1957, 1958, 1959.

of revision.



SUFFIX LETTERS

(May be used singly or in combination)

These suffix letters, when appended to the grade number, signify that the requirements for which they stand are to be met, if no method of test is provided, or if no value for the suffix letter requirement is specified in the tables, agreement as to method of test and required value shall be arranged between the purchaser and the supplier.

NGTH
D 412)

psi

500

500

500

500

500

500

REF-
USE
NS.

ly Chart

LETTER	TESTS REQUIRED	ASTM Applicable Test Method
A1	Heat Aging for 70 hr at 212 F	D 573, D 865
B	Compression Set	D 395
C	Weather Resistance	D 1171
D	Load Deflection	D 575
E1	Oil Resistance - ASTM Oil No. 1	D 471
E3	Oil Resistance - ASTM Oil No. 3	D 471
E4	Oil Resistance - Hydrocarbon test fluid	D 471
F1	Low-Temperature Brittleness at -40 F	D 746
F2	Low-Temperature Brittleness at -67 F	D 746
G	Tear Resistance	D 624
H	Flex Resistance	D 430
J	Abrasion Resistance	D 394
K1	Adhesion to Metal (Bond made during vulcanization)	D 429
K2	Adhesion (Cemented bond made after vulcanization)	D 429
L	Water Resistance	D 471
M	Flammability Resistance	
N	Impact Resistance	
P	Non-Staining	D 925
R	Resilience	D 945
S1	Low-Temperature Stiffness at -40 F	D 1053
S2	Low-Temperature Stiffness at -67 F	D 1053
Z	Special Requirements	

ASTM STANDARDS; SAE HANDBOOK, STANDARD J14.
ENGINEERING AND MATERIALS, 1018 RACE ST., PHILADELPHIA 3, PA.

Fig. 28 KEY CHART TO ELASTOMETERS COMPOUND (ASTM Standards, D-735)

	<u>Method of Test</u>
k1 - adhesion to metal	D-429
R - resilience	D-945

The minimum physical requirements for this compound are shown in Fig. 29 (ASTM-D-735).

Bond. The bond between the case and the rubber and between the rubber and the shaft could be made during vulcanization. Modern technology in rubber-to-metal bonding allows shear stresses of 500 psi and higher. A shear stress of 300 psi will be assumed in the coaxial spring design.

Steel. The shaft, case and lever arms should be built of low carbon alloy steel and protected from corrosion by an anti-oxidant coating such as neoprene or other plastic or paint.

DESIGN EXAMPLE

A fender system for an open type pier should be designed for the following conditions:

Ship.-	Displacement	50,000 DWT
	Total Displacement	65,000 Long tons
	Length	740 ft
	Beam	105 ft
	Depth	50 ft
	Max. Draft	38 ft
	Light Draft	10 ft
	Approach velocity, normal to the pier	0.3 fps

Grade Number	Basic Requirements							Requirements Added by Suffix Letter ^a		
	Durometer Hardness No.	Tensile Strength, min, psi	Ultimate Elongation, per cent	Heat Aged 70 hr at 158 F			Compression Set After 22 hr at 158 F, max, per cent	Suffix B	Suffix D	Suffix R
				Change in Tensile Strength, max, per cent	Change in Ultimate Elongation, max, per cent	Change in Durometer Hardness, max		Compression Set After 22 hr at 158 F, max, per cent	Load at 20 per cent Deformation, psi	Yerzley Resilience at 20 per cent Deformation, min, per cent
R310	30 ± 5	1000	400	-25	-35	+10	50	25
R315	30 ± 5	1500	500	-25	-35	+10	50	25	70 ± 10	...
R320	30 ± 5	2000	600	-25	-35	+10	50	25	70 ± 10	...
R325	30 ± 5	2500	600	-25	-35	+10	50	35	70 ± 10	...
R410	40 ± 5	1000	400	-25	-35	+10	50	25
*R415	40 ± 5	1500	500	-25	-35	+7	50	25	100 ± 15	70
*R420	40 ± 5	2000	500	-25	-35	+7	50	25	100 ± 15	75
R425	40 ± 5	2500	500	-25	-35	+7	50	25	100 ± 15	80
R430	40 ± 5	3000	600	-25	-35	+7	50	35	100 ± 15	80
R505	50 ± 5	500	300	-25	-35	+10	50
R508	50 ± 5	800	350	-25	-35	+10	50
*R510	50 ± 5	1000	400	-25	-35	+10	50	25
R512	50 ± 5	1200	400	-25	-35	+10	50	25
*R515	50 ± 5	1500	400	-25	-35	+7	50	25	140 ± 20	65
*R520	50 ± 5	2000	500	-25	-35	+7	50	25	140 ± 20	65
*R525	50 ± 5	2500	500	-25	-35	+7	50	25	140 ± 20	75
R530	50 ± 5	3000	600	-25	-35	+7	50	35	140 ± 20	75
R535	50 ± 5	3500	600	-25	-35	+7	50	35	140 ± 20	75
R605	60 ± 5	500	300	-25	-35	+10	50
R608	60 ± 5	800	300	-25	-35	+10	50
*R610	60 ± 5	1000	300	-25	-35	+10	50	25
R612	60 ± 5	1200	300	-25	-35	+10	50	25
*R615	60 ± 5	1500	350	-25	-35	+7	50	25	195 ± 30	60
*R620	60 ± 5	2000	400	-25	-35	+7	50	25	195 ± 30	60
*R625	60 ± 5	2500	450	-25	-35	+7	50	25	195 ± 30	70
R630	60 ± 5	3000	500	-25	-35	+7	50	35	195 ± 30	70
R635	60 ± 5	3500	550	-25	-35	+7	50	35	195 ± 30	70
R705	70 ± 5	500	150	-25	-35	+10	50
R708	70 ± 5	800	150	-25	-35	+10	50
*R710	70 ± 5	1000	200	-25	-35	+10	50	25
R712	70 ± 5	1200	200	-25	-35	+10	50	25
*R715	70 ± 5	1500	250	-25	-35	+7	50	25	300 ± 70	50
*R720	70 ± 5	2000	300	-25	-35	+7	50	25	300 ± 70	50
R725	70 ± 5	2500	300	-25	-35	+7	50	25	300 ± 70	60
R730	70 ± 5	3000	400	-25	-35	+7	50	35	300 ± 70	60
R805	80 ± 5	500	100	-25	-35	+10	50
R810	80 ± 5	1000	100	-25	-35	+10	50
R815	80 ± 5	1500	150	-25	-35	+7	50	...	475 ± 100	...
R820	80 ± 5	2000	200	-25	-35	+7	50	...	475 ± 100	...
R825	80 ± 5	2500	200	-25	-35	+7	50	...	475 ± 100	...
R905	90 ± 5	500	75	-25	-35	+10	50
R910	90 ± 5	1000	100	-25	-35	+10	50
R915	90 ± 5	1500	125	-25	-35	+7	50

Fig. 29 PHYSICAL REQUIREMENTS OF TYPE R COMPOUNDS, NON OIL RESISTANT (ASTM Standards, Part 30, D-735, 1965)

Harbor. -	Tidal Range	4 ft
	Waves, max.	6 ft
	Wave Period	4.5 sec
	Wind	40 knots
	Current, max.	2 knots
	Seismic Effect	Zone 3

a) Berthing Energy

$$E_a = 1/2 M V^2 C_m C_e C_s C_c$$

$$E_o = 1/2 (65,000/32.2) \times 2240 \times (0.3)^2 = 204,000 \text{ lb-ft}$$

$$C_m = 1 + \frac{2D}{B}$$

$$= 1 + \frac{2 \times 38}{105} = 1.72$$

$$C_e = \frac{k^2}{b^2 + k^2}$$

Assume $k = 0.2 L$, $b = 0.3 L$

$$C_e = \frac{L^2 \times (0.2)^2}{L^2 (0.3^2 + 0.2^2)} = 0.31$$

Assume $C_s = 0.9 = 0.90$

and for open type pier

$$C_c = 1.0 = 1.00$$

$$E_a = 204,000 \times 1.72 \times 0.31 \times 0.9 \times 1.0$$

$$= 204,000 \times 0.48 = 100,000 \text{ lb-ft}$$

The fender system should be designed to absorb 100,000 lb-ft of berthing energy.

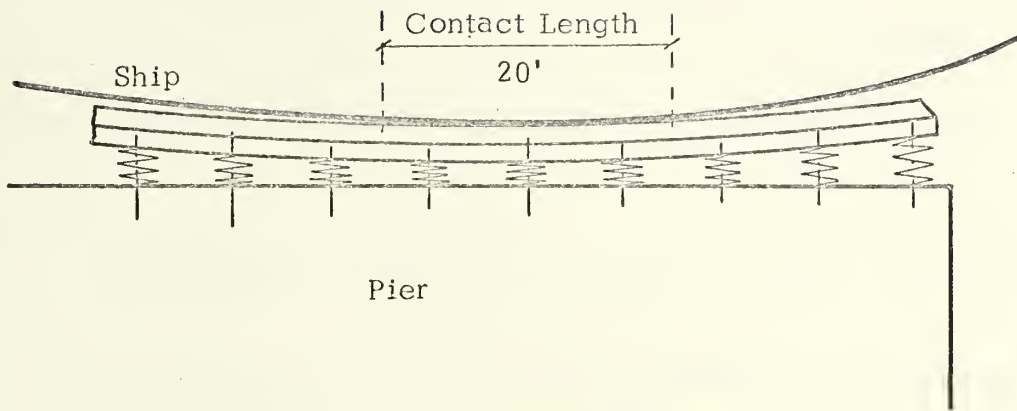

(a) Ship Striking Center of Fender

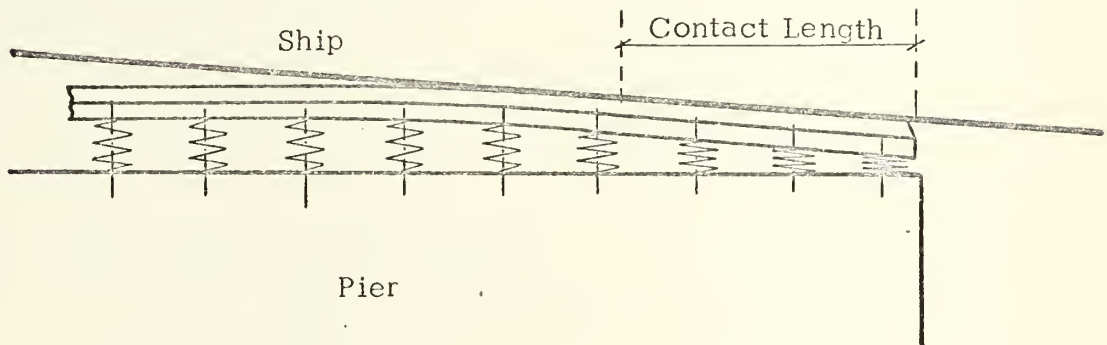

(b) Ship Striking End of Fender

Fig. 30 CONTACT LENGTH, SHIP STRIKING WHARF

b) The next step is to find the contact length between the ship and the fender system. Using the hull drawings of a typical ship, the contact length at first can be assumed. Then the contact length should be checked when the spring constant of the fender is known.

In the problem presented, if a contact length of 20 ft is assumed, there are three buffers working and if a buffer three feet long is used (see Fig. 30),

$$E_a/\text{linear ft} = \frac{100,000}{3 \times 3} = 11,100 \text{ lb-ft/ft}$$

c) As a first approach, assume a fender deflection (or retraction) of 12 in. If the lever arm $n = 24$ in., by geometry

$$\sin \theta = 12/24$$

$$\text{Then, } \theta = 30^\circ$$

and based on the static approach

$$E = 1/2 T \theta$$

$$11,100 = 1/2 T \left(\frac{30}{57.3} \right)$$

$$T = \frac{2 \times 11,100 \times 57.3}{30}$$

$$= 42,400 \text{ lb-ft}$$

$$= 508,000 \text{ lb-in.}$$

d) Assume for the rubber the following characteristics:

Durometer hardness, D	55
Modulus of Rigidity, G	105 psi
Stress in bond, f_s	300 psi

The critical stress is present in the bond between the shaft and the rubber, therefore the internal diameter of the rubber is

$$T = 2 \pi R_1^2 L f_s \quad (65)$$

$$508,000 = 2 \pi R_1^2 \times 12 \times 300$$

$$R_1^2 = \frac{508,000}{2 \pi (12) (300)}$$

$$R_1 = 4.74 \text{ in.}$$

Since pipes are manufactured in standard sizes, use a radius $R_1 = 5.375 \text{ in.}$ corresponding to a 10 in., ASA-80 pipe and applying Eq. 70,

$$\frac{30}{57.3} = \frac{508,000}{4 \pi \times 12 \times 105} \left(\frac{1}{5.375^2} - \frac{1}{R_2^2} \right)$$

$$\frac{1}{R_2^2} = \frac{1}{5.375^2} - \frac{30 \times 4 \times \pi \times 12 \times 105}{573 \times 508,000}$$

$$R_2^2 = 54.7$$

$$R_2 = 7.40 \text{ in.}$$

Use $R_2 = 7.5 \text{ in.}$

$$\text{and } k = 4 \pi L G \left(\frac{R_1^2 R_2^2}{R_2^2 - R_1^2} \right) \quad (81)$$

$$= 4 \pi \times 12 \times 105 \left(\frac{5.375^2 \cdot 7.5^2}{7.5^2 - 5.375^2} \right)$$

$$= 940,490 \text{ lb-in.}$$

e) Maximum reaction, R_x

$$T = F_n \cdot n \quad (a)$$

$$T = k \cdot \theta \quad (b)$$

but $F_n = F \sin(\beta + \theta)$

and equating (a) and (b)

$$k \theta = F \cdot n \cdot \sin(\beta + \theta)$$

$$F = -R_x$$

$$R_x = \frac{k \theta}{n \sin(\beta + \theta)} \quad (84)$$

The value of the maximum angle of twist, θ_{\max} , is

$$E = 1/2 k \theta^2$$

$$\theta = \sqrt{\frac{2 \times 11,100 \times 12}{940,490}} \times 57.3$$

$$= \sqrt{0.2832} \times 57.3$$

$$\theta = 30.5^\circ$$

and the maximum deflection for $\beta = 50^\circ$

$$d_{\max} = n (\cos 50 - \cos 80.5)$$

$$= 24 (0.643 - 0.165)$$

$$= 11.48 \text{ in.}$$

The maximum reaction $R_{x \max}$ ($\theta = 30.5^\circ$, $\beta = 50^\circ$) is now

$$R_{x \max} = \frac{940,490 \times 30.5}{24 \times \sin 80.5^\circ \times 57.3}$$

$$= 21,100 \text{ lb}$$

The total reaction on the pier, R , is

$$\begin{aligned} R &= R_{x \max} \times 9 \\ &= 21,100 \times 9 \\ &= 189,900 \text{ lb} \end{aligned}$$

Assuming that the longitudinal load (parallel to the pier) is 20% of the perpendicular load, the total longitudinal load is

$$\begin{aligned} R_{\text{long}} &= 0.2 \times 189,900 \\ &= 37,980 \text{ lb} \end{aligned}$$

f) Checking using dynamic solution

Using the Runge-Kutta method to solve the differential equation and applying the computer program given in Chapter VI, it is possible to compute the value of the reaction R_x as a function of the twist angle, $\theta(t)$. Additional values, like the angular velocity and the energy absorbed by the buffer, are printed in the output as shown on the following pages.

The output was determined for three different values of the initial angle of the lever arm, β (45° , 50° and 55°). As can be seen, the reaction, R_x , has a small increase when the initial angle, β , decreases. The stop time and the deflection (or retraction of the buffer) increase when the initial angle, β , increases.

g) Load-deflection curve and time required to stop the ship

Fig. 31 shows the load-deflection curves for the statical and dynamical solution. The statical curve was plotted according to Eq. (84) and the dynamical curve was plotted using the output of the

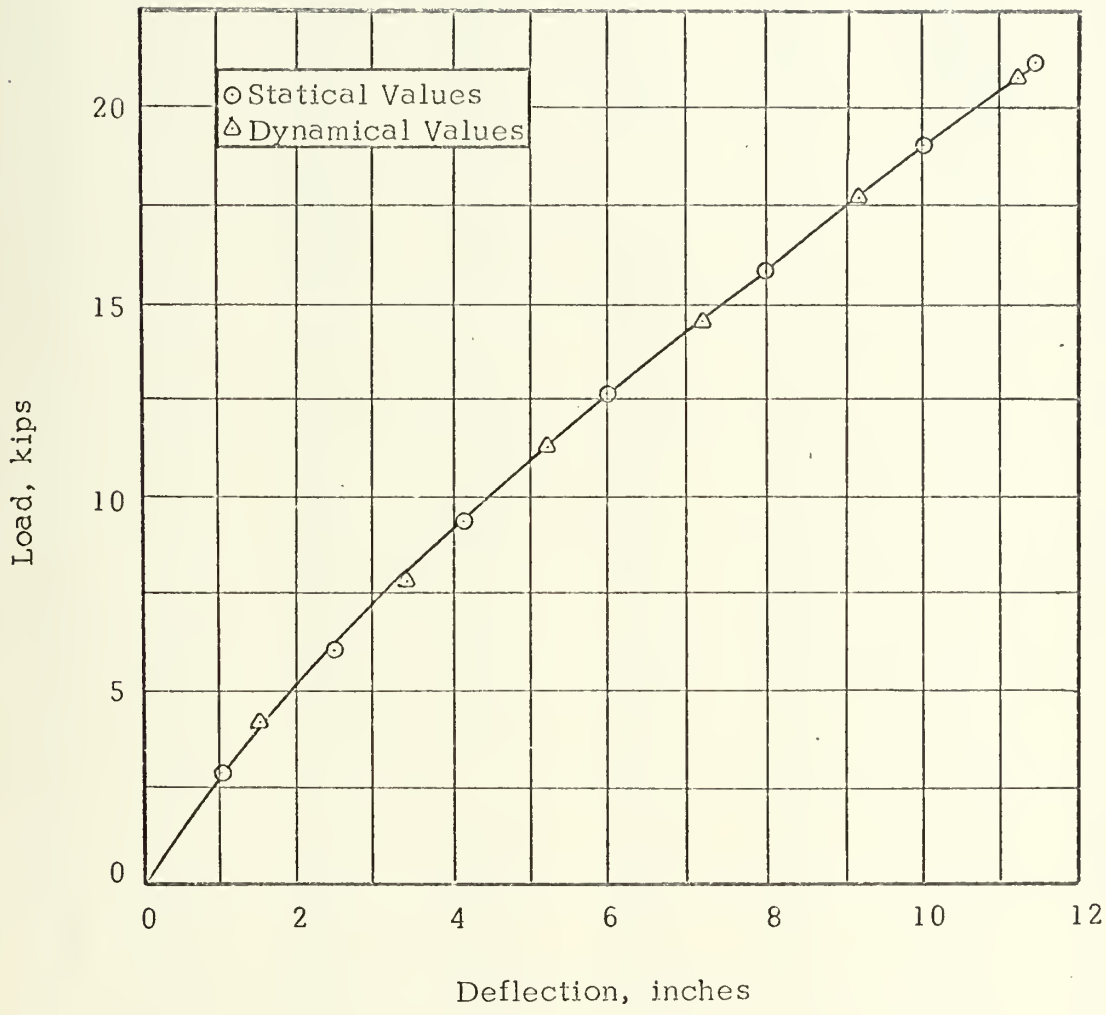

Fig. 31 COAXIAL TUBE RUBBER BUFFER, STATICAL AND DYNAMICAL LOAD-DEFLECTION CURVE

	BETA	TIME	ANGLE	ANG.VEL	DEFLEC	REACTION	ENERGY
1	45.0	0.050	0.605	12.027	0.180	578.7	4.3
2	45.0	0.100	1.203	11.899	0.360	1139.6	17.2
3	45.0	0.150	1.795	11.772	0.540	1683.8	38.4
4	45.0	0.200	2.380	11.645	0.719	2212.0	67.5
5	45.0	0.250	2.959	11.519	0.899	2725.0	104.4
6	45.0	0.300	3.532	11.394	1.078	3223.6	148.8
7	45.0	0.350	4.098	11.269	1.256	3708.5	200.3
8	45.0	0.400	4.659	11.145	1.434	4180.3	258.9
9	45.0	0.450	5.213	11.021	1.612	4639.7	324.2
10	45.0	0.500	5.761	10.898	1.789	5087.1	395.9
11	45.0	0.550	6.303	10.775	1.965	5523.1	473.9
12	45.0	0.600	6.838	10.653	2.141	5948.3	557.9
13	45.0	0.650	7.368	10.532	2.316	6363.0	647.7
14	45.0	0.700	7.892	10.411	2.490	6767.8	743.1
15	45.0	0.750	8.409	10.290	2.664	7163.0	843.8
16	45.0	0.800	8.921	10.170	2.836	7548.9	949.5
17	45.0	0.850	9.426	10.050	3.008	7926.0	1060.2
18	45.0	0.900	9.926	9.930	3.179	8294.6	1175.6
19	45.0	0.950	10.419	9.811	3.348	8655.0	1295.4
20	45.0	1.000	10.907	9.692	3.517	9007.6	1419.5
21	45.0	1.050	11.388	9.574	3.685	9352.4	1547.7
22	45.0	1.100	11.864	9.455	3.851	9690.0	1679.7
23	45.0	1.150	12.334	9.337	4.016	10020.4	1815.4
24	45.0	1.200	12.798	9.220	4.180	10343.9	1954.5
25	45.0	1.250	13.256	9.102	4.343	10660.8	2097.0
26	45.0	1.300	13.708	8.984	4.504	10971.2	2242.5
27	45.0	1.350	14.154	8.867	4.665	11275.4	2390.9
28	45.0	1.400	14.595	8.750	4.823	11573.4	2542.0
29	45.0	1.450	15.029	8.633	4.981	11865.5	2695.6
30	45.0	1.500	15.458	8.516	5.136	12151.9	2851.6
31	45.0	1.550	15.881	8.399	5.291	12432.6	3009.8
32	45.0	1.600	16.298	8.282	5.444	12707.9	3169.9
33	45.0	1.650	16.709	8.165	5.595	12977.8	3331.9
34	45.0	1.700	17.114	8.048	5.745	13242.5	3495.5
35	45.0	1.750	17.514	7.931	5.893	13502.1	3660.6
36	45.0	1.800	17.907	7.814	6.039	13756.7	3827.0
37	45.0	1.850	18.295	7.696	6.184	14006.4	3994.6
38	45.0	1.900	18.677	7.579	6.327	14251.3	4163.1
39	45.0	1.950	19.053	7.462	6.469	14491.5	4332.4
40	45.0	2.000	19.423	7.345	6.608	14727.1	4502.4
41	45.0	2.050	19.788	7.227	6.746	14958.0	4672.9
42	45.0	2.100	20.146	7.110	6.882	15184.6	4843.7
43	45.0	2.150	20.498	6.992	7.016	15406.6	5014.7
44	45.0	2.200	20.845	6.874	7.149	15624.4	5185.8
45	45.0	2.250	21.186	6.756	7.279	15837.8	5356.7
46	45.0	2.300	21.521	6.638	7.408	16047.0	5527.4
47	45.0	2.350	21.850	6.519	7.534	16252.0	5697.6
48	45.0	2.400	22.173	6.400	7.659	16452.8	5867.3
49	45.0	2.450	22.490	6.281	7.781	16649.6	6036.3
50	45.0	2.500	22.801	6.162	7.902	16842.2	6204.5
51	45.0	2.550	23.106	6.043	8.020	17030.8	6371.7
52	45.0	2.600	23.405	5.923	8.137	17215.4	6537.8
53	45.0	2.650	23.698	5.804	8.251	17396.1	6702.6

54	45.0	2.700	23.985	5.683	8.363	17572.7	6866.0
55	45.0	2.750	24.267	5.563	8.473	17745.5	7027.9
56	45.0	2.800	24.542	5.442	8.581	17914.3	7188.2
57	45.0	2.850	24.811	5.322	8.687	18079.3	7346.7
58	45.0	2.900	25.074	5.200	8.790	18240.3	7503.3
59	45.0	2.950	25.331	5.079	8.891	18397.6	7657.9
60	45.0	3.000	25.582	4.957	8.990	18550.9	7810.4
61	45.0	3.050	25.827	4.835	9.087	18700.4	7960.6
62	45.0	3.100	26.065	4.713	9.182	18846.1	8108.4
63	45.0	3.150	26.298	4.590	9.274	18988.0	8253.8
64	45.0	3.200	26.524	4.467	9.364	19126.1	8396.6
65	45.0	3.250	26.745	4.344	9.451	19260.3	8536.6
66	45.0	3.300	26.959	4.221	9.537	19390.7	8673.9
67	45.0	3.350	27.167	4.097	9.619	19517.4	8808.2
68	45.0	3.400	27.368	3.973	9.700	19640.2	8939.5
69	45.0	3.450	27.564	3.849	9.778	19759.2	9067.7
70	45.0	3.500	27.753	3.724	9.854	19874.4	9192.7
71	45.0	3.550	27.936	3.599	9.927	19985.8	9314.4
72	45.0	3.600	28.113	3.474	9.998	20093.3	9432.7
73	45.0	3.650	28.284	3.349	10.066	20197.1	9547.5
74	45.0	3.700	28.448	3.223	10.132	20297.0	9658.8
75	45.0	3.750	28.606	3.097	10.196	20393.1	9766.4
76	45.0	3.800	28.758	2.971	10.257	20485.4	9870.3
77	45.0	3.850	28.903	2.845	10.315	20573.8	9970.3
78	45.0	3.900	29.042	2.718	10.371	20658.4	10066.5
79	45.0	3.950	29.175	2.592	10.425	20739.1	10158.8
80	45.0	4.000	29.301	2.464	10.476	20816.0	10247.0
81	45.0	4.050	29.421	2.337	10.524	20889.0	10331.1
82	45.0	4.100	29.535	2.210	10.570	20958.2	10411.1
83	45.0	4.150	29.642	2.082	10.613	21023.5	10486.9
84	45.0	4.200	29.743	1.954	10.654	21084.9	10558.4
85	45.0	4.250	29.838	1.826	10.692	21142.4	10625.6
86	45.0	4.300	29.926	1.698	10.728	21196.0	10688.5
87	45.0	4.350	30.008	1.570	10.761	21245.7	10746.9
88	45.0	4.400	30.083	1.441	10.791	21291.6	10800.9
89	45.0	4.450	30.152	1.313	10.819	21333.5	10850.4
90	45.0	4.500	30.214	1.184	10.844	21371.5	10895.4
91	45.0	4.550	30.270	1.055	10.867	21405.6	10935.8
92	45.0	4.600	30.320	0.926	10.887	21435.7	10971.6
93	45.0	4.650	30.363	0.797	10.905	21462.0	11002.8
94	45.0	4.700	30.399	0.668	10.919	21484.3	11029.4
95	45.0	4.750	30.430	0.539	10.932	21502.6	11051.3
96	45.0	4.800	30.453	0.410	10.941	21517.1	11068.5
97	45.0	4.850	30.471	0.281	10.948	21527.6	11081.1
98	45.0	4.900	30.481	0.151	10.953	21534.2	11088.9
99	45.0	4.950	30.486	0.022	10.954	21536.8	11092.1

	BETA	TIME	ANGLE	ANG. VEL	DEFLEC	REACTION	ENERGY
1	50.0	0.050	0.559	11.128	0.180	494.8	3.7
2	50.0	0.100	1.113	11.035	0.360	977.8	14.8
3	50.0	0.150	1.662	10.942	0.540	1449.4	32.9
4	50.0	0.200	2.207	10.849	0.719	1910.1	58.1
5	50.0	0.250	2.747	10.755	0.899	2360.4	90.0
6	50.0	0.300	3.282	10.661	1.078	2800.7	128.5
7	50.0	0.350	3.813	10.566	1.257	3231.2	173.5
8	50.0	0.400	4.339	10.472	1.435	3652.5	224.6
9	50.0	0.450	4.860	10.377	1.613	4064.9	281.8
10	50.0	0.500	5.377	10.281	1.790	4468.7	344.9
11	50.0	0.550	5.888	10.186	1.967	4864.1	413.7
12	50.0	0.600	6.395	10.091	2.144	5251.6	488.0
13	50.0	0.650	6.897	9.995	2.319	5631.4	567.7
14	50.0	0.700	7.395	9.899	2.494	6003.7	652.5
15	50.0	0.750	7.887	9.802	2.669	6368.7	742.3
16	50.0	0.800	8.375	9.706	2.842	6726.9	837.0
17	50.0	0.850	8.858	9.609	3.015	7078.2	936.3
18	50.0	0.900	9.336	9.513	3.186	7423.1	1040.1
19	50.0	0.950	9.809	9.415	3.357	7761.6	1148.2
20	50.0	1.000	10.278	9.318	3.527	8093.9	1260.5
21	50.0	1.050	10.741	9.221	3.696	8420.3	1376.8
22	50.0	1.100	11.200	9.123	3.864	8740.9	1496.9
23	50.0	1.150	11.653	9.025	4.031	9055.8	1620.6
24	50.0	1.200	12.102	8.926	4.197	9365.3	1747.8
25	50.0	1.250	12.546	8.828	4.361	9669.4	1878.4
26	50.0	1.300	12.985	8.729	4.525	9968.3	2012.2
27	50.0	1.350	13.419	8.630	4.687	10262.1	2148.9
28	50.0	1.400	13.848	8.531	4.848	10551.0	2288.5
29	50.0	1.450	14.272	8.431	5.008	10835.0	2430.9
30	50.0	1.500	14.691	8.331	5.166	11114.2	2575.7
31	50.0	1.550	15.105	8.231	5.323	11388.8	2723.0
32	50.0	1.600	15.514	8.130	5.479	11658.9	2872.4
33	50.0	1.650	15.918	8.029	5.633	11924.5	3024.0
34	50.0	1.700	16.317	7.928	5.786	12185.7	3177.5
35	50.0	1.750	16.711	7.827	5.937	12442.7	3332.7
36	50.0	1.800	17.100	7.725	6.087	12695.4	3489.6
37	50.0	1.850	17.483	7.622	6.235	12943.9	3648.0
38	50.0	1.900	17.862	7.520	6.382	13188.3	3807.7
39	50.0	1.950	18.235	7.417	6.527	13428.7	3968.6
40	50.0	2.000	18.604	7.313	6.670	13665.1	4130.5
41	50.0	2.050	18.967	7.210	6.812	13897.5	4293.3
42	50.0	2.100	19.325	7.105	6.952	14126.1	4456.8
43	50.0	2.150	19.677	7.001	7.091	14350.8	4621.0
44	50.0	2.200	20.025	6.896	7.227	14571.8	4785.6
45	50.0	2.250	20.367	6.790	7.362	14788.9	4950.6
46	50.0	2.300	20.704	6.685	7.495	15002.3	5115.7
47	50.0	2.350	21.035	6.578	7.626	15212.0	5280.9
48	50.0	2.400	21.361	6.472	7.756	15418.0	5446.0
49	50.0	2.450	21.682	6.365	7.883	15620.4	5610.8
50	50.0	2.500	21.998	6.257	8.009	15819.1	5775.4
51	50.0	2.550	22.308	6.149	8.132	16014.2	5939.4
52	50.0	2.600	22.613	6.041	8.254	16205.7	6102.8
53	50.0	2.650	22.912	5.932	8.374	16393.6	6265.4

54	50.0	2.700	23.206	5.822	8.492	16577.9	6427.1
55	50.0	2.750	23.494	5.713	8.607	16758.7	6587.9
56	50.0	2.800	23.777	5.602	8.721	16935.9	6747.5
57	50.0	2.850	24.055	5.492	8.833	17109.5	6905.8
58	50.0	2.900	24.326	5.381	8.942	17279.6	7062.8
59	50.0	2.950	24.593	5.269	9.050	17446.2	7218.2
60	50.0	3.000	24.853	5.157	9.155	17609.2	7372.0
61	50.0	3.050	25.108	5.044	9.258	17768.6	7524.1
62	50.0	3.100	25.358	4.931	9.359	17924.5	7674.3
63	50.0	3.150	25.601	4.818	9.458	18076.9	7822.6
64	50.0	3.200	25.840	4.704	9.554	18225.7	7968.7
65	50.0	3.250	26.072	4.590	9.649	18370.9	8112.7
66	50.0	3.300	26.298	4.475	9.741	18512.6	8254.3
67	50.0	3.350	26.519	4.360	9.831	18650.6	8393.5
68	50.0	3.400	26.734	4.244	9.919	18785.1	8530.3
69	50.0	3.450	26.944	4.128	10.004	18916.0	8664.3
70	50.0	3.500	27.147	4.011	10.087	19043.3	8795.7
71	50.0	3.550	27.345	3.894	10.168	19167.0	8924.3
72	50.0	3.600	27.537	3.777	10.246	19287.0	9049.9
73	50.0	3.650	27.723	3.659	10.322	19403.4	9172.5
74	50.0	3.700	27.903	3.541	10.396	19516.2	9292.0
75	50.0	3.750	28.077	3.423	10.467	19625.2	9408.3
76	50.0	3.800	28.245	3.304	10.536	19730.6	9521.4
77	50.0	3.850	28.407	3.185	10.603	19832.3	9631.1
78	50.0	3.900	28.563	3.065	10.667	19930.3	9737.3
79	50.0	3.950	28.714	2.945	10.729	20024.6	9840.0
80	50.0	4.000	28.858	2.825	10.788	20115.1	9939.1
81	50.0	4.050	28.996	2.704	10.845	20201.9	10034.5
82	50.0	4.100	29.128	2.583	10.899	20285.0	10126.2
83	50.0	4.150	29.254	2.462	10.951	20364.2	10214.1
84	50.0	4.200	29.374	2.340	11.000	20439.7	10298.1
85	50.0	4.250	29.488	2.218	11.047	20511.4	10378.2
86	50.0	4.300	29.596	2.096	11.092	20579.2	10454.2
87	50.0	4.350	29.698	1.973	11.134	20643.3	10526.2
88	50.0	4.400	29.793	1.851	11.173	20703.5	10594.1
89	50.0	4.450	29.883	1.728	11.210	20759.8	10657.8
90	50.0	4.500	29.966	1.605	11.244	20812.3	10717.3
91	50.0	4.550	30.043	1.481	11.276	20861.0	10772.6
92	50.0	4.600	30.114	1.358	11.305	20905.7	10823.5
93	50.0	4.650	30.179	1.234	11.332	20946.6	10870.2
94	50.0	4.700	30.238	1.110	11.356	20983.6	10912.4
95	50.0	4.750	30.290	0.986	11.378	21016.6	10950.3
96	50.0	4.800	30.336	0.862	11.397	21045.8	10983.8
97	50.0	4.850	30.376	0.738	11.413	21071.1	11012.7
98	50.0	4.900	30.410	0.614	11.427	21092.4	11037.3
99	50.0	4.950	30.438	0.489	11.439	21109.8	11057.3
100	50.0	5.000	30.459	0.365	11.448	21123.3	11072.8
101	50.0	5.050	30.474	0.240	11.454	21132.8	11083.8
102	50.0	5.100	30.483	0.116	11.458	21138.5	11090.3

	BETA	TIME	ANGLE	ANG. VEL	DEFLEC	REACTION	ENERGY
1	55.0	0.050	0.523	10.425	0.180	433.9	3.3
2	55.0	0.100	1.043	10.357	0.360	859.6	13.0
3	55.0	0.150	1.559	10.287	0.540	1277.5	29.0
4	55.0	0.200	2.071	10.217	0.719	1687.7	51.2
5	55.0	0.250	2.580	10.146	0.899	2090.6	79.4
6	55.0	0.300	3.086	10.074	1.078	2486.3	113.6
7	55.0	0.350	3.588	10.001	1.257	2875.1	153.6
8	55.0	0.400	4.086	9.928	1.436	3257.2	199.2
9	55.0	0.450	4.581	9.854	1.614	3632.8	250.3
10	55.0	0.500	5.071	9.780	1.792	4002.1	306.9
11	55.0	0.550	5.558	9.705	1.969	4365.3	368.7
12	55.0	0.600	6.042	9.629	2.145	4722.6	435.6
13	55.0	0.650	6.521	9.552	2.322	5074.1	507.5
14	55.0	0.700	6.997	9.475	2.497	5420.0	584.2
15	55.0	0.750	7.469	9.398	2.672	5760.4	665.7
16	55.0	0.800	7.937	9.319	2.846	6095.6	751.7
17	55.0	0.850	8.401	9.241	3.020	6425.5	842.2
18	55.0	0.900	8.861	9.161	3.192	6750.5	937.0
19	55.0	0.950	9.317	9.081	3.364	7070.5	1035.9
20	55.0	1.000	9.769	9.001	3.535	7385.8	1138.9
21	55.0	1.050	10.217	8.920	3.705	7696.4	1245.7
22	55.0	1.100	10.661	8.838	3.874	8002.4	1356.4
23	55.0	1.150	11.101	8.756	4.042	8304.0	1470.6
24	55.0	1.200	11.536	8.673	4.209	8601.2	1588.3
25	55.0	1.250	11.968	8.590	4.375	8894.2	1709.4
26	55.0	1.300	12.395	8.506	4.540	9182.9	1833.7
27	55.0	1.350	12.819	8.422	4.704	9467.6	1961.0
28	55.0	1.400	13.238	8.337	4.867	9748.2	2091.3
29	55.0	1.450	13.652	8.251	5.029	10024.9	2224.4
30	55.0	1.500	14.063	8.165	5.189	10297.7	2360.2
31	55.0	1.550	14.469	8.079	5.348	10566.7	2498.5
32	55.0	1.600	14.871	7.991	5.506	10831.9	2639.2
33	55.0	1.650	15.268	7.904	5.662	11093.4	2782.1
34	55.0	1.700	15.661	7.815	5.817	11351.3	2927.2
35	55.0	1.750	16.050	7.726	5.971	11605.5	3074.2
36	55.0	1.800	16.434	7.637	6.123	11856.2	3223.1
37	55.0	1.850	16.813	7.547	6.274	12103.4	3373.8
38	55.0	1.900	17.188	7.456	6.424	12347.1	3526.0
39	55.0	1.950	17.559	7.365	6.572	12587.4	3679.6
40	55.0	2.000	17.925	7.273	6.718	12824.3	3834.6
41	55.0	2.050	18.286	7.181	6.863	13057.8	3990.8
42	55.0	2.100	18.643	7.088	7.006	13287.9	4148.0
43	55.0	2.150	18.995	6.994	7.148	13514.7	4306.2
44	55.0	2.200	19.342	6.900	7.288	13738.2	4465.1
45	55.0	2.250	19.685	6.805	7.426	13958.4	4624.7
46	55.0	2.300	20.023	6.709	7.563	14175.3	4784.8
47	55.0	2.350	20.356	6.613	7.697	14389.0	4945.3
48	55.0	2.400	20.684	6.517	7.831	14599.4	5106.1
49	55.0	2.450	21.007	6.419	7.962	14806.5	5267.0
50	55.0	2.500	21.326	6.321	8.091	15010.5	5428.0
51	55.0	2.550	21.640	6.223	8.219	15211.1	5588.8
52	55.0	2.600	21.948	6.123	8.345	15408.6	5749.3
53	55.0	2.650	22.252	6.024	8.469	15602.9	5909.5

54	55.0	2.700	22.551	5.923	8.591	15793.9	6069.3
55	55.0	2.750	22.844	5.822	8.711	15981.6	6228.3
56	55.0	2.800	23.133	5.720	8.829	16166.2	6386.7
57	55.0	2.850	23.416	5.618	8.946	16347.5	6544.2
58	55.0	2.900	23.695	5.515	9.060	16525.5	6700.7
59	55.0	2.950	23.968	5.412	9.172	16700.3	6856.1
60	55.0	3.000	24.236	5.307	9.282	16871.8	7010.3
61	55.0	3.050	24.499	5.203	9.391	17040.1	7163.1
62	55.0	3.100	24.756	5.097	9.497	17205.0	7314.5
63	55.0	3.150	25.008	4.991	9.601	17366.6	7464.3
64	55.0	3.200	25.255	4.885	9.703	17524.9	7612.4
65	55.0	3.250	25.497	4.777	9.802	17679.9	7758.7
66	55.0	3.300	25.733	4.670	9.900	17831.5	7903.1
67	55.0	3.350	25.964	4.561	9.995	17979.8	8045.5
68	55.0	3.400	26.189	4.452	10.089	18124.6	8185.8
69	55.0	3.450	26.409	4.343	10.180	18266.0	8323.8
70	55.0	3.500	26.623	4.233	10.268	18404.0	8459.5
71	55.0	3.550	26.832	4.122	10.355	18538.6	8592.8
72	55.0	3.600	27.035	4.011	10.439	18669.7	8723.5
73	55.0	3.650	27.233	3.899	10.521	18797.2	8851.6
74	55.0	3.700	27.425	3.787	10.601	18921.3	8976.9
75	55.0	3.750	27.612	3.674	10.679	19041.8	9099.4
76	55.0	3.800	27.793	3.560	10.754	19158.8	9219.0
77	55.0	3.850	27.968	3.446	10.826	19272.2	9335.6
78	55.0	3.900	28.137	3.332	10.897	19382.0	9449.1
79	55.0	3.950	28.301	3.217	10.965	19488.1	9559.4
80	55.0	4.000	28.459	3.102	11.031	19590.6	9666.4
81	55.0	4.050	28.611	2.986	11.094	19689.5	9770.0
82	55.0	4.100	28.758	2.870	11.155	19784.6	9870.3
83	55.0	4.150	28.898	2.753	11.214	19876.1	9967.0
84	55.0	4.200	29.033	2.636	11.270	19963.8	10060.2
85	55.0	4.250	29.162	2.519	11.323	20047.7	10149.7
86	55.0	4.300	29.285	2.401	11.375	20127.9	10235.5
87	55.0	4.350	29.402	2.283	11.423	20204.3	10317.5
88	55.0	4.400	29.513	2.164	11.470	20276.8	10395.7
89	55.0	4.450	29.618	2.045	11.514	20345.6	10469.9
90	55.0	4.500	29.717	1.926	11.555	20410.4	10540.2
91	55.0	4.550	29.811	1.806	11.594	20471.5	10606.5
92	55.0	4.600	29.898	1.686	11.630	20528.6	10668.7
93	55.0	4.650	29.979	1.566	11.664	20581.8	10726.8
94	55.0	4.700	30.055	1.446	11.696	20631.2	10780.8
95	55.0	4.750	30.124	1.325	11.725	20676.6	10830.5
96	55.0	4.800	30.187	1.204	11.751	20718.0	10876.1
97	55.0	4.850	30.244	1.083	11.775	20755.5	10917.3
98	55.0	4.900	30.296	0.962	11.796	20789.1	10954.3
99	55.0	4.950	30.341	0.841	11.815	20818.7	10986.9
100	55.0	5.000	30.380	0.719	11.831	20844.3	11015.1
101	55.0	5.050	30.413	0.598	11.845	20865.9	11039.0
102	55.0	5.100	30.439	0.476	11.856	20883.5	11058.5
103	55.0	5.150	30.460	0.354	11.865	20897.2	11073.6
104	55.0	5.200	30.475	0.232	11.871	20906.8	11084.3
105	55.0	5.250	30.483	0.110	11.875	20912.4	11090.5

computer program. Both values were selected for an initial angle $\beta = 50^\circ$. As can be seen the two curves fit in one line.

The total time required to stop the ship was 5.1 sec; therefore the statical solution is adequate in the solution of the problem as was pointed out in Chapter VI and proved by the load-deflection curves shown in Fig. 31.

h) Shaft, Case and Lever Arms

It is not intended to give a complete design of the shaft, case and lever arms. Only the most important dimensions will be investigated.

The total torque in each device will be (length = 3 ft).

$$\begin{aligned} T &= F \times n \times L \\ &= 21,100 \times 24 \times \sin 80.5^\circ \times 3 \\ &= 1,490,000 \text{ lb-in.} \end{aligned}$$

If a 10 in. ASA-140 pipe is used,

$$\begin{aligned} R_e &= 5.375 \text{ in.} \\ J &= 735.6 \text{ in.}^4 \end{aligned}$$

the shear-stress in the pipe due to the torque is

$$\begin{aligned} f_{V1} &= \frac{T \times R_e}{J} \\ &= \frac{1,490,000 \times 5.375}{735.6} \\ &= 10,900 \text{ psi} \end{aligned}$$

The area of the pipe is 30.63 sq. in. and the shear-stress in the pipe due to the applied load is

$$\begin{aligned} f_{V2} &= \frac{63,300}{30.63} \\ &= 2080 \text{ psi} \end{aligned}$$

and the maximum shear-stress in the pipe is

$$\begin{aligned} f_{\max} &= f_{V1} + f_{V2} \\ &= 10,900 + 2080 \\ &= 13,000 \text{ psi} \end{aligned}$$

A steel with $F_y = 36$ ksi can be used ($F_v = 14,500$ psi).

The case can be cast in two pieces or built using steel plates.

Fig. 32 shows a possible design.

The lever arms should be made of low carbon steel, minimum $F_y = 42$ ksi, and welded to the shaft. The maximum bending stress at the periphery of the shaft is ($f_b = 25,000$ psi).

$$\begin{aligned} M_b &= 21,100 \times 3/2 \times (24 - 5.375) \\ &= 590,000 \text{ lb-in.} \end{aligned}$$

$$f = \frac{MC}{I} \qquad S_y = \frac{I}{C}$$

$$\begin{aligned} S_y &= \frac{590,000}{25,000} \\ &= 23.6 \text{ in.}^3 \end{aligned}$$

The minimum section modulus of the lever arm at the periphery of the shaft should be 23.6 in.^3 . If the longitudinal forces (20% of perpendicular forces are taken into account,

$$\begin{aligned} f_b &= \frac{M_x}{S_x} + \frac{M_y}{S_y} \\ 25,000 &= \frac{M_x}{S_x} + \frac{0.2 M_x}{S_y} \end{aligned}$$

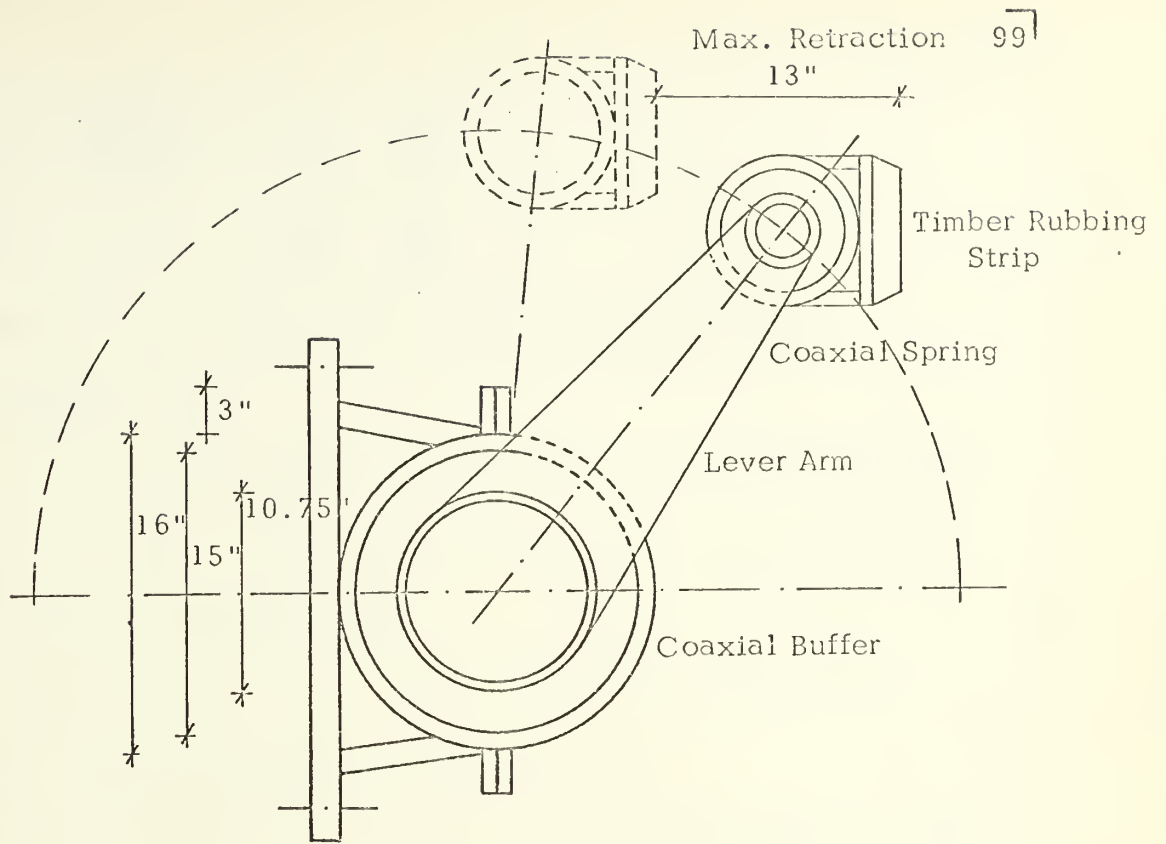

(a) Coaxial Buffer

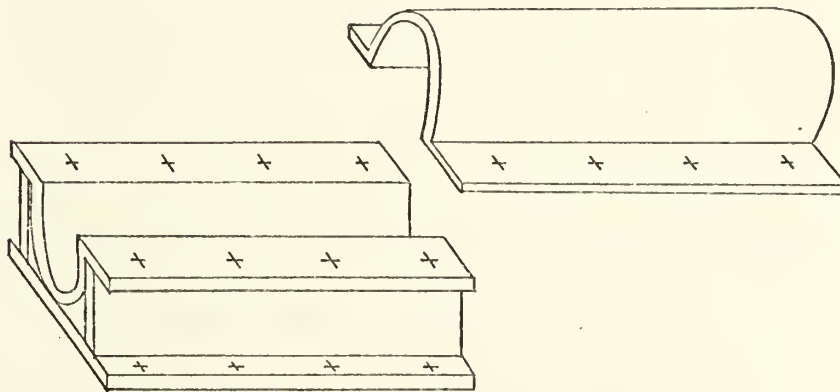

(b) Steel Case

Fig. 32 COAXIAL TUBE BUFFER DETAIL

$$\frac{25,000}{590,000} = \frac{1}{S_y} + \frac{0.2}{S_z}$$

$$0.043 = \frac{1}{S_y} + \frac{0.2}{S_z}$$

and a section that satisfies this relationship should be used.

k) Rubbing strip

In the present problem the tidal range is only 4 ft and fender piles are not needed. The rubbing surface can be built as a steel structure with wood rubbing strips.

From the different designs that are possible, one may be a continuous steel beam attached to the lever arms.

Because the angle between the lever arm and the rubbing surface changes during retraction, an articulated union should be provided and coaxial rubber unions (similar to the principal spring) may be used.

1) In article (b), the contact length of the ship was assumed 20 ft. To find the real contact length the bow curve of the ship should be compared with the load-deflection curve of the fender system (see Reeves³⁶). The problem of equating the total energy absorbed by the fender system can be solved using solutions of beams on elastic foundations. Since the coaxial tube spring does not have a linear load-deflection curve, the stiffness factor for each buffer varied according to the load. To solve this problem, at first, an estimate of the deflection curve can be made and then using a computer, the final answer can be determined. This study should be made for different angles of approach of the ship.

m) Comparison of different types of fenders

Fig. 33 shows approximate load-deflection curves for different types of buffers that could be used in the fender system study in Chapter VII. All the buffers absorb 34,000 lb-ft of energy and retract 12 in.

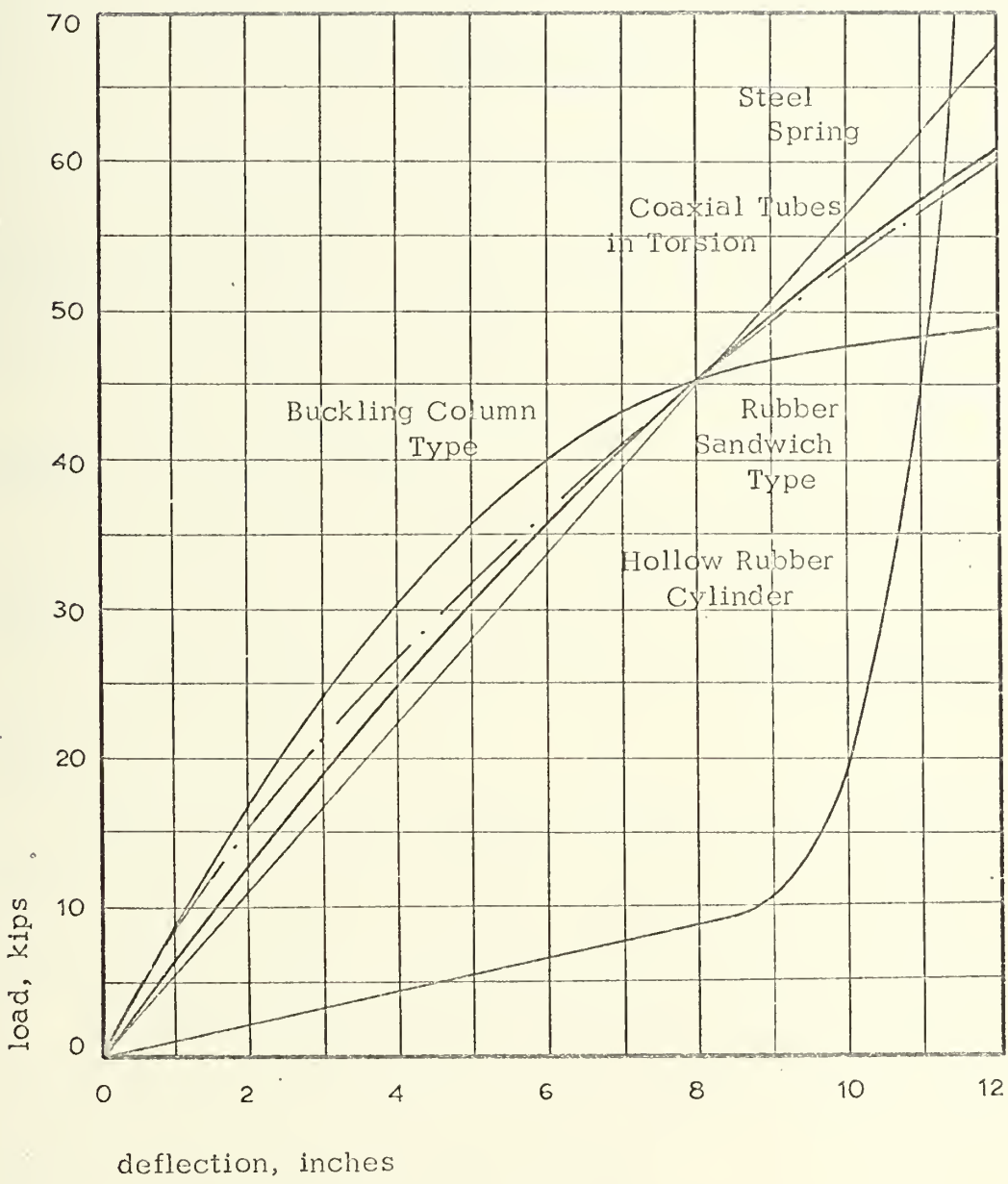

Fig. 33 LOAD-DEFLECTION CURVES FOR DIFFERENT TYPES OF MARINE FENDERS

CHAPTER VIII

CONCLUSIONS

a. A comparison of the coaxial tube buffer with the essential and desirable requirements of a fendering system for general purpose wharfs as given in Chapter III is as follows.

1. High absorbing capacity for impact energy so as to eliminate damages to the main structure.

The coaxial tube buffer complied with this requirement as was shown in the design example in Chapter VII.

2. Appreciable elastic movement so as to eliminate damage to the berthing vessel.

Using a rubber with a durometer hardness of 55 the retraction was 11.5 in. which is considered adequate. Varying the durometer hardness of the rubber is possible to get other deflections if it is desired.

The pressure per linear foot in the ship's hull is $189,900/20 = 9,490$ lb/ft which is less than that recommended by NAVFAC-DM-25, page 25-1-51 (10,000 to 15,000 lb per ft).

3. Adaptability to both wall-sided and belted vessels berthing alongside.

The steel wale supported by the elastic springs has enough flexural capacity to adapt to both wall-sided and belted vessels.

4. Long serviceable life, low maintenance and least renewal.

The life of the coaxial buffer depends on the life of the rubber.

The life of the natural rubber is very long and because the load is not permanently applied to the buffer, the expected creep will be very small.

With proper maintenance of the steel parts, the buffer will have a long life.

5. Minimum capital or annual cost.

The cost of this buffer is very difficult to estimate. The bond-to-metal process will be the determining factor in the increase in cost.

Of course it will be more expensive than the hung cylindrical rubber fender but the reaction of this type is 4 to 5 times the reaction of the coaxial tube fender. If it is compared with other types of fenders working in shear like the Raykin fender, the volume of natural rubber needed for the coaxial tube is less than the rubber needed for the Raykin fender. Both buffers need rubber-to-metal bond but the bond in the coaxial tube looks more difficult than the Raykin sandwiches.

If the tidal range is small and fender piles are not needed, the coaxial tube type has all advantages in cost over the Raykin type because the Raykin type needs additional devices to support the rubbing surface which are not needed in the coaxial tube.

6. Capability of absorbing inclined impacts and rubbing forces to eliminate damage to fendering.

The coaxial tube buffer has the capability to absorb impact in any direction.

7. Having, together with the main structure, sufficient static resistance and mass to cause plastic deformation of the ship's hull in order to save the main structure if hit by an abnormal impact.

The static resistance of the coaxial tube buffer is similar to other types of buffers. Its mass is relatively small compared with the mass of the pier.

8. Capability of absorbing work from a bumping vessel at exposed berths.

The coaxial tube buffer is not affected by rough seas, therefore can meet this requirement without any trouble.

9. Avoidance of over rigidity and stiffness.

The reaction of the coaxial tube buffer increases gradually with the deflection, therefore the movement is gentle.

b. Load-Deflection Curve

The reaction of the coaxial tube buffer is within the values of the rubber sandwich buffer and is approximately 10% higher than the buckling column type buffer, as shown in Fig. 33.

c. Theoretical vs. Practical Application

According to theory it is possible to build a buffer using the coaxial tube principle as was shown in Chapter VII; however, different values were assumed and other values changed during the manufacturing process. The only way to get a realistic solution is by building a model to study its performance in a laboratory.

LIST OF REFERENCES

1. Glenn B. Woodruff, BERTHING AND MOORING FORCES, Journal of the Waterways and Harbors Division, ASCE, Vol. 88, No. WW1, February 1962.
2. B. F. Saurin, BERTHING FORCES OF LARGE TANKERS, Sixth WPC in Francfort/Main, June 1963, Section VII - Paper 10, p. 3.
3. Lord Manufacturing Company, BRIDGESTONE MARINE FENDERS, AIA File No. 32-A-3, p. II.C.2.
4. B. F. Saurin, Paper 10, p. 4.
5. Robert W. Abbet and Zusse Leviton, DESIGN AND CONSTRUCTION OF TERMINALS FOR LARGE SHIPS, XX International Navigation Congress, Baltimore 1961, SII-1.
6. Shu-t'ien-Li, OPERATIVE ENERGY CONCEPT IN MARINE FENDERING, Journal of Waterways and Harbors Division, ASCE, Vol. 87, No. WW3, August, 1961.
7. B. F. Saurin, Paper 10, p. 3.
8. Lord Manufacturing Company, NOMOGRAPH ENERGY CAPACITY REQUIREMENTS FOR MARINE FENDERS, Bulletin 88-C.
9. G. B. Woodruff, Vol. 88, p. 74.
10. G. B. Woodruff, Vol. 88, p. 74.
11. Basil W. Wilson, SHIP RESPONSE TO RANGE ACTION IN HARBOR BASINS, Transaction ASCE, Vol. 116, 1951, Paper No. 2460, p. 1146.
12. Ibid., p. 1148.
13. Shu-t'ien Li, EVALUATION OF MOORING FORCES, Journal of the Waterways and Harbors Division, ASCE, Vol. 88, No. WW4, November 1962, p.33.
14. Shu-t'ien Li, p. 34:

15. H. M. Westergaard, WATER PRESSURES ON DAMS DURING EARTH-QUAKES, Transaction, ASCE, Vol. 98, 1933.
16. Shu-t'ien Li, OPERATIVE ENERGY CONCEPT IN MARINE FENDERING, Journal of Waterways and Harbors Division, ASCE, Vol. 87, No. WW3, August, 1961.
17. Ibid.
18. Robert D. Chellis, PILE FOUNDATIONS, McGraw-Hill Book Company, New York, 1961.
19. Alonzo de F. Quinn, DESIGN AND CONSTRUCTION OF PORTS AND MARINE STRUCTURES, McGraw-Hill Book Company, New York, 1962.
20. Robert N. Endebrok, A STUDY OF MARINE FENDERING SYSTEMS, Unpublished report, Tulane University, 1962.
21. Ibid.
22. Lord Manufacturing Company, FLEXIBLE DOCK FENDERS, Bulletin 800.
23. Robert R. Palmer and Virgil Blancato, NEW RETRACTABLE MARINE FENDERING SYSTEM, Journal of the Waterways and Harbors Division, ASCE, Vol. 84, No. WW1, January 1958.
24. Virgil Blancato and Joseph H. Finger, OFFSHORE MOORING ISLAND FOR SUPERTANKERS, Journal of the Waterways and Harbors Division, ASCE, Vol. 88, No. WW4, November 1962.
25. United States Navy, DESIGN MANUAL, NAVFAC-DM-26, Chapter 5, Section 1, Part 3.
26. United States Navy, DESIGN MANUAL, NAVFAC-DM-25, Chapter 1, Section 3, Part 2.
27. John M. Weiss, and Virgil Blancato, A BREASTING DOLPHIN FOR BERTHING SUPERTANKERS, Journal of the Waterways and Harbors Division, ASCE, Vol. 85, No. WW3, September 1959, Part I.
28. A.L.L. Baker, REPORT OF THE WORK OF THE XVIII CONGRESS, International Navigation Congress, Rome, 1953, Second Question, p. 189.

29. United States Navy, DESIGN MANUAL, NAVFAC-DM-25, Chapter 1, Section 5, Part 2.
30. Walter E. Burton, ENGINEERING WITH RUBBER, McGraw-Hill Book Company, New York, 1949.
31. J. F. Downie Smith, RUBBER SPRINGS-SHEAR LOADING, Journal of Applied Mechanics, December 1939.
32. J. F. Downie Smith, RUBBER SPRINGS-SHEAR LOADING-II, Transaction of the ASME, April 1948.
33. F. Seely and J. Smith, RESISTANCE OF MATERIALS, John Wiley and Sons, New York 1959.
34. Peter A. Stark, INTRODUCTION TO NUMERICAL METHODS, McMillan Company, 1970.
35. B. Carnahan, H. Luther and J. Wilkes, APPLIED NUMERICAL METHODS, John Wiley and Sons, 1969.
36. H.W. Reeves, MARINE OIL TERMINAL FOR RIO DE JANEIRO, BRAZIL, Journal of the Waterways and Harbors Division, Vol. 87, No. WW1, February 1961.

BIOGRAPHY

Enrique R. Malfanti, Lieutenant Commander, Chilean Navy, was born on November 13, 1933, in San Felipe, Chile. He attended high school in Valparaiso, Chile.

In February 1948 he entered the Chilean Naval Academy and was graduated as Ensign, on January 1, 1952.

After serving four years on board he attended the Chilean Naval Engineering School and was graduated as Electrical Engineer in December 1958.

Between 1959 and 1968 he served on board and ashore in different assignments as electrical officer, chief engineer, professor of Electrical Machinery and Applied Thermodynamics in the Naval Engineering School and head of the Electrical Department, Bureau of Ships.

In September 1968 he was awarded a Scholarship by the United States Navy and he began work on a Master of Science Degree in Civil Engineering at Tulane University of Louisiana and is a candidate for this degree in August of 1970.

Upon return to Chile in September 1970, LTCD Malfanti is assigned to the Bureau of Civil Construction, Chilean Navy, Valparaiso, Chile.

He is a registered Engineer in Chile and a member of the "Colegio de Ingeniero de Chile" (Chilean Engineers Association).

Thesis
M2782

120227

Malfanti

Analysis of exist-
ing marine fendering
systems and analysis
of a marine fender

2 DEC 19 1954
system utilizing tor-
sional resistance.

Thesis
M2782

120227

Malfanti

Analysis of exist-
ing marine fendering
systems and analysis
of a marine fender
system utilizing tor-
sional resistance.

thesM2782

Analysis of existing marine fendering sy



3 2768 002 04216 0

DUDLEY KNOX LIBRARY