

6994

Library of the Museum  
OF  
COMPARATIVE ZOÖLOGY,  
AT HARVARD COLLEGE, CAMBRIDGE, MASS.

The gift of the Royal Microscopical  
Society

No. 6994  
Mar. 12, 1894 - Jan. 10, 1895















JOURNAL  
OF THE  
ROYAL  
MICROSCOPICAL SOCIETY;

CONTAINING ITS TRANSACTIONS AND PROCEEDINGS,  
AND A SUMMARY OF CURRENT RESEARCHES RELATING TO  
ZOOLOGY AND BOTANY  
(principally Invertebrata and Cryptogamia),  
MICROSCOPY, &c.

*Edited by*

**F. JEFFREY BELL, M.A.,**

*One of the Secretaries of the Society  
and Professor of Comparative Anatomy and Zoology in King's College;*

WITH THE ASSISTANCE OF THE PUBLICATION COMMITTEE AND

A. W. BENNETT, M.A., B.Sc., F.L.S.,  
*Lecturer on Botany at St. Thomas's Hospital,*  
R. G. HEBB, M.A., M.D. (*Canab.*), AND

J. ARTHUR THOMSON, M.A.,  
*Lecturer on Zoology in the School of Medicine,  
Edinburgh.*

FELLOWS OF THE SOCIETY.

FOR THE YEAR  
1894.



S<sub>W1</sub>

LONDON:

TO BE OBTAINED AT THE SOCIETY'S ROOMS,  
20 HANOVER SQUARE, W.;  
OF MESSRS. WILLIAMS & NORGATE; AND OF MESSRS. DULAU & CO.





THE

# Royal Microscopical Society.

(Established in 1839. Incorporated by Royal Charter in 1866.)

The Society was established for the promotion of Microscopical and Biological Science by the communication, discussion and publication of observations and discoveries relating to (1) improvements in the construction and mode of application of the Microscope, or (2) Biological or other subjects of Microscopical Research.

It consists of Ordinary, Honorary, and Ex-officio Fellows, without distinction of sex.

**Ordinary Fellows** are elected on a Certificate of Recommendation, signed by three Ordinary Fellows, setting forth the names, residence, and description of the Candidate, of whom the first proposer must have personal knowledge. The Certificate is read at two General Meetings, and the Candidate balloted for at the second Meeting.

The Admission Fee is 2*l.* 2*s.*, and the Annual Subscription 2*l.* 2*s.*, payable on election, and subsequently in advance on 1st January annually, but future payments may be compounded for at any time for 3*l.* 10*s.* Fellows elected at a meeting subsequent to that in February are only called upon for a proportionate part of the first year's subscription. The annual Subscription of Fellows permanently residing abroad is 1*l.* 11*s.* 6*d.*, or a reduction of one-fourth.

**Honorary Fellows** (limited to 50), consisting of persons eminent in Microscopical or Biological Science, are elected on the recommendation of five Ordinary Fellows and the approval of the Council.

**Ex-officio Fellows** (limited to 100), consisting of the Presidents for the time being of any Societies having objects in whole or in part similar to those of the Society, are elected on the recommendation of ten Ordinary Fellows, and the approval of the Council.

**The Council**, in whom the management of the property and affairs of the Society is vested, is elected annually, and is composed of the President, four Vice-Presidents, Treasurer, two Secretaries, and twelve other Ordinary Fellows.

**The Meetings** are held on the third Wednesday in each month, from October to June, at 20 Hanover Square, W. (commencing at 8 P.M.). Visitors are admitted by the introduction of Fellows.

In most Sessions there is a *Conversazione* devoted to the exhibition of Instruments, Apparatus, and Objects of novelty or interest relating to the Microscope or the subjects of Microscopical Research.

**The Journal**, containing the Transactions and Proceedings of the Society, and a Summary of Current Researches relating to Zoology and Botany (principally Invertebrata and Cryptogamia), Microscopy, &c., is published bi-monthly, and is forwarded post-free to all Ordinary and Ex-officio Fellows residing in countries within the Postal Union.

**The Library**, with the Instruments, Apparatus, and Cabinet of Objects, is open for the use of Fellows daily (except Saturdays), from 10 A.M. to 5 P.M., and, from November 1st to June 30th, on every Wednesday evening from 6 P.M. to 10 P.M. (except Meeting nights). It is closed for four weeks during August and September.

*Forms of proposal for Fellowship, and any further information, may be obtained by application to the Secretaries, or Assistant-Secretary, at the Library of the Society, 20 Hanover Square, W.*

# Patron

HIS ROYAL HIGHNESS  
ALBERT EDWARD, PRINCE OF WALES,  
K.G., G.C.B., F.R.S., &c.

## Past Presidents.

	Elected
*SIR RICHARD OWEN, K.C.B., D.C.L., M.D., LL.D., F.R.S.	1840-1
*JOHN LINDLEY, Ph.D., F.R.S. ....	1842-3
*THOMAS BELL, F.R.S. ....	1844-5
*JAMES SCOTT BOWERBANK, LL.D., F.R.S. ....	1846-7
*GEORGE BUSK, F.R.S. ....	1848-9
*ARTHUR FARRE, M.D., F.R.S. ....	1850-1
*GEORGE JACKSON, M.R.C.S. ....	1852-3
*WILLIAM BENJAMIN CARPENTER, C.B., M.D., LL.D., F.R.S..	1854-5
GEORGE SHADBOLT ....	1856-7
*EDWIN LANKESTER, M.D., LL.D., F.R.S. ....	1858-9
*JOHN THOMAS QUEKETT, F.R.S. ....	1860
*ROBERT JAMES FARRANTS, F.R.C.S. ....	1861-2
*CHARLES BROOKE, M.A., F.R.S. ....	1863-4
JAMES GLAISHER, F.R.S. ....	1865-6-7-8
*REV. JOSEPH BANCROFT READE, M.A., F.R.S. ....	1869-70
*WILLIAM KITCHEN PARKER, F.R.S. ....	1871-2
*CHARLES BROOKE, M.A., F.R.S. ....	1873-4
HENRY CLIFTON SOBRY, LL.D., F.R.S. ....	1875-6-7
HENRY JAMES SLACK, F.G.S. ....	1878
LIONEL S. BEALE, M.B., F.R.C.P., F.R.S. ....	1879-80
*P. MARTIN DUNCAN, M.B., F.R.S. ....	1881-2-3
REV. W. H. DALLINGER, LL.D., F.R.S. ....	1884-5-6-7
CHARLES T. HUDSON, M.A., LL.D. (Cantab.) ....	1888-9-90
ROBERT BRAITHWAITE, M.D., M.R.C.S., F.L.S. ....	1891-2

\* Deceased.



# COUNCIL.

ELECTED 17TH JANUARY, 1894.

---

## President.

ALBERT D. MICHAEL, Esq., F.L.S.

## Vice-Presidents.

PROF. LIONEL S. BEALE, Esq., M.B., F.R.C.P., F.R.S.

\*ROBERT BRAITHWAITE, Esq., M.D., M.R.C.S., F.L.S.

\*FRANK CRISP, Esq., LL.B., B.A., V.P. & TREAS. L.S.

THOMAS H. POWELL, Esq.

## Treasurer.

WILLIAM THOMAS SUFFOLK, Esq.

## Secretaries.

PROF. F. JEFFREY BELL, M.A.

REV. W. H. DALLINGER, LL.D., F.R.S.

## Ordinary Members of Council.

CONRAD BECK, Esq.

ALFRED W. BENNETT, Esq., M.A., B.Sc., F.L.S.

REV. EDMUND CARR, M.A., F.R.Met.S.

EDWARD DADSWELL, Esq.

RICHARD G. HEBB, Esq., M.A., M.D., F.R.C.P.

\*GEORGE C. KAROP, Esq., M.R.C.S.

EDWARD MILLES NELSON, Esq.

PROF. URBAN PRITCHARD, M.D.

C. F. ROUSSELET, Esq.

\*PROF. CHARLES STEWART, Pres. L.S.

J. J. VEZEY, Esq.

THOS. CHARTERS WHITE, Esq., M.R.C.S., L.D.S.

\* Members of the Publication Committee.

---

## Librarian and Assistant Secretary.

MR. W. H. BROWN.



# CONTENTS.

TRANSACTIONS OF THE SOCIETY—

	PAGE
I. New British Freshwater Algæ. By William West, F.L.S., assisted by G. S. West. (Plates I. and II.) .. .. .	1
II. The President's Address: The Progress and Present State of our Knowledge of the Acari. By A. D. Michael, F.L.S. .. .. .	18
III. The Foraminifera of the Gault of Folkestone.—V. By Frederick Chapman, F.R.M.S. (Plates III. and IV.) .. .. .	153
IV. An Inexpensive Screen for Monochromatic Light. By J. William Gifford, F.R.M.S. (Plate V.) .. .. .	164
V. On <i>Fucitrogus Rhodymenia</i> , a Gall-producing Copepod. By G. S. Brady, M.D., LL.D., F.R.S. (Plate V.).. .. .	168
VI. Notes on the Uropodina. By A. D. Michael, P.R.M.S., F.L.S., F.Z.S., &c. (Plates VI. and VII.) .. .. .	289
VII. The Foraminifera of the Gault of Folkestone.—VI. By Frederick Chapman, F.R.M.S. (Plate VIII.) .. .. .	421
VIII. On the Unreliability of certain Characters, generally accepted for Specific Diagnosis in the Diatomaceæ. By Thomas Comber, F.R.M.S., F.L.S.	428
IX. The Foraminifera of the Gault of Folkestone.—VII. By Frederick Chapman, F.R.M.S. (Plates IX. and X.) .. .. .	645
X. On a Simple Method of Measuring the Refractive Indices of Mounting and Immersion Media. By Edward M. Nelson, F.R.M.S. .. .. .	655

SUMMARY OF CURRENT RESEARCHES RELATING TO ZOOLOGY AND BOTANY (PRINCIPALLY INVERTEBRATA AND CRYPTOGAMIA), MICROSCOPY, &c., INCLUDING ORIGINAL COMMUNICATIONS FROM FELLOWS AND OTHERS.\*

34, 171, 320, 433, 541, 660

## ZOOLOGY.

### A.—Vertebrata :—Embryology, Histology, and General.

#### a. Embryology.

	PAGE
BORN, G., & W. ROUX— <i>Experimental Embryology</i> .. .. .	34
GORONOWITSCH, N.— <i>Ectodermic Origin of Skeletal Rudiments</i> .. .. .	35
MALL, F.— <i>Human Embryo of Second Week</i> .. .. .	35
ABY, F. S.— <i>Development of Hypophysis Cerebri in the Domestic Cat</i> .. .. .	35
HAYCRAFT, J. B.— <i>Development of Wolfian Body in Chick and Rabbit</i> .. .. .	36
KÜKENTHAL, W.— <i>Dentition of Pinnipedia</i> .. .. .	36
RÖSE, C.— <i>Dentition of Wombat</i> .. .. .	37
GORONOWITSCH, N.— <i>Ganglion Ridges in the Head of Birds</i> .. .. .	37
LECHE, W.— <i>Development of Teeth in Iguana</i> .. .. .	38
BEMMELEN, J. F. VAN— <i>Development of Gill-pouches and Aortic Arches in Chelonia</i>	38
FICK, R.— <i>Maturation and Fertilization of Egg of Azolol</i> .. .. .	38
PLATT, J. B.— <i>Ontogenetic Differentiations of Ectoderm in Necturus</i> .. .. .	39
MORGAN, T. H.— <i>Experimental Studies on Eggs of Teleosteans</i> .. .. .	40

\* In order to make the Contents complete, (1) the papers printed in the 'Transactions,' (2) the abstracts of the 'Bibliography,' and (3) the notes printed in the 'Proceedings' are included here.

	PAGE
KOEHLER, R., & E. BATAILLON— <i>Growth of Blastoderm in Teleosteans</i> .. .. .	40
BATAILLON, E., & R. KOEHLER— <i>Karyokinetic Phenomena in Cells of Blastoderm of Teleosteans</i> .. .. .	41
KLAATSCH, H.— <i>Vertebral Column of Fishes</i> .. .. .	41
HOFFMANN, C. K.— <i>Origin of Vascular System in Selachii</i> .. .. .	42
HERFORD, K. V.— <i>Maturation of the Ovum of the Lamprey</i> .. .. .	43
HERTWIG, O.— <i>Experimental Embryology</i> .. .. .	171
BOS, RITZEMA— <i>Breeding in and in</i> .. .. .	172
HAACKE, W.— <i>Origin of Mammals</i> .. .. .	172
LECHE, W.— <i>Dentition of Mammals</i> .. .. .	173
SOBOTTA, J.— <i>Fertilization in the Mouse</i> .. .. .	174
REICHEL, P.— <i>Development of Bladder and Urethra</i> .. .. .	174
GAUPP, E.— <i>Development of the Hypophysis</i> .. .. .	174
HOFFMANN, C. K.— <i>Origin of the Blood</i> .. .. .	175
POLLARD, H. B.— <i>Development of Head of Gobius Capito</i> .. .. .	175
MITROPHANOW, P.— <i>Embryogeny of Selachii</i> .. .. .	175
LOCY, W. A.— <i>Derivation of the Pineal Eye</i> .. .. .	176
HASSE, C.— <i>Development of the Vertebral Column</i> .. .. .	176
MINOT, C. S.— <i>Concerning the Gonotome</i> .. .. .	176
REH, L.— <i>Inheritance of Acquired Characters</i> .. .. .	176
ROUX, W.— <i>Experimental Embryology</i> .. .. .	320
HUBRECHT, A. A. W.— <i>Placentation of the Shrew</i> .. .. .	321
KIP, M. J. VAN ERP TAALMAN— <i>Development of Müllerian Duct in Mammals</i> .. .. .	322
PRENANT, M. A.— <i>Development of Thymus, Thyroid, and Carotid Glands</i> .. .. .	323
BAMBEKE, C. VAN— <i>Median Groove of Triton</i> .. .. .	324
BLANC, H.— <i>Fecundation of Egg of Trout</i> .. .. .	324
HASSE, C.— <i>Vertebral Column of Ganoids</i> .. .. .	324
JUNGENSEN, H. F. E.— <i>Development of Kidneys in Sturgeon</i> .. .. .	325
MINOT, C. S.— <i>Bibliography of Vertebrate Embryology</i> .. .. .	325
SEDGWICK, A.— <i>Von Baer's Law and the Significance of Ancestral Rudiments in Embryonic Development</i> .. .. .	433
WEISMANN, A.— <i>Effect of External Conditions on Development</i> .. .. .	434
ZIEGLER, H. E.— <i>Yolk-nuclei in Meroblastic Ova</i> .. .. .	435
BLANC, H.— <i>Fertilization of Trout's Ovum</i> .. .. .	435
RÖSE, C.— <i>Development of the Teeth in the Adder</i> .. .. .	435
FIELD, H. H.— <i>Development of Excretory System in Amphiuma</i> .. .. .	435
BEARD, J.— <i>Development of the Thymus</i> .. .. .	436
LENDENFELD, R. VON— <i>Haacke's Theory of Gemmaria</i> .. .. .	436
HUBRECHT, A. A. W.— <i>Morphology of Placenta</i> .. .. .	541
HOLL, M.— <i>Maturation of the Ovum in Mammals</i> .. .. .	541
LOCY, W. A.— <i>Segmentation in Medullary Folds and Embryonic Rim</i> .. .. .	542
WOODWARD, M. F.— <i>Succession and Genesis of Mammalian Teeth</i> .. .. .	542
" " <i>Milk Dentition of Rodents</i> .. .. .	542
POULTON, E. B.— <i>Homologies and Origin of Mammalian Hair</i> .. .. .	543
SAINT-REMY, G.— <i>Relations of Notochord and Hypophysis in Birds</i> .. .. .	544
DRASCH, O.— <i>Formation of Somatopleure and Vessels in the Chick</i> .. .. .	544
PLATT, J. B.— <i>Ectodermic Differentiation in Necturus</i> .. .. .	544
MINGAZZINI, P.— <i>Degeneration of Frog Ova</i> .. .. .	545
BORN, G.— <i>Structure of the Nucleus in the Ovarian Ovum of Triton</i> .. .. .	545
RÖSE, C.— <i>Development of Teeth in Fishes</i> .. .. .	546
HILL, C.— <i>Epiphysis of Teleostean Fishes and of Amia</i> .. .. .	546
JUNGENSEN, H. F. E.— <i>Development of the Kidneys in Amia calva</i> .. .. .	546
SCHAPER, A.— <i>Development of Cerebellum in Teleostei</i> .. .. .	547
HARRISON, R. G.— <i>Development of Fins of Teleostei</i> .. .. .	547
HUBBARD, J. W.— <i>Yolk-nucleus in Cymatogaster aggregatus</i> .. .. .	548
HOFFMANN, C. K.— <i>Development of the Selachian Head</i> .. .. .	548
EISMOND, J.— <i>Development of Amphioxus</i> .. .. .	549
HERTWIG, O., & OTHERS— <i>Experimental Embryology</i> .. .. .	660
GIACOMINI, C.— <i>An Abnormal Human Embryo</i> .. .. .	661
KLAATSCH, H.— <i>Origin of the Scleroblasts</i> .. .. .	661
GEGENBAUR, C.— <i>Phylogeny of the Tongue</i> .. .. .	662
HOCHSTETTER, F.— <i>Development of Venous System of Mammals</i> .. .. .	662



	PAGE
HIROTA, S.— <i>Sero-Amniotic Connection and Fœtal Membranes of Chick</i> .. .. .	663
MITSUKURI, K.— <i>Gastrulation in Chelonia</i> .. .. .	664
LANGER, A.— <i>Development of Bulbus Cordis in Amphibians and Reptiles</i> .. .. .	664
HOCHSTETTER, F.— <i>Development of Abdominal Vein in Amphibia</i> .. .. .	665
LUNDBORG, H.— <i>Development of Hypophysis and Saccus vasculosus in Teleostei and Amphibia</i> .. .. .	665
HOLM, J. F.— <i>Development of Olfactory Organ in Teleostei</i> .. .. .	665
M'INTOSH, W. C.— <i>Ova and Larvæ of British Fishes</i> .. .. .	665

### β. Histology.

REINKE, F.— <i>Minute Structure of the Cell</i> .. .. .	43
ROUX, W.— <i>Interactions between Cell-substance and Nucleus</i> .. .. .	43
HEIDENHAIN, M.— <i>Nucleus and Protoplasm</i> .. .. .	44
DEMOOR, L.— <i>Structure of Reticulated Tissue</i> .. .. .	44
NCSEBAUM, J.— <i>Behaviour of Pigment-granules during Karyokinesis</i> .. .. .	44
RATH, O. VOM.— <i>Spermatogenesis in Salamandra maculosa</i> .. .. .	177
HÄCKER, V.— <i>Import of the Chief Nucleolus</i> .. .. .	178
HARDY, W. B., & LIM BOON KENG.— <i>Changes induced by Urari in the Wandering Cells of the Frog</i> .. .. .	178
RAMON Y CAJAL.— <i>Minute Structure of Nerve-centres</i> .. .. .	325
LENHOSSÉK, M. V.— <i>Nerve-cord of Rays</i> .. .. .	326
ZOJA, L. & R.— <i>Altmann's Bioplasts</i> .. .. .	326
DRÜNER, L.— <i>Degeneration of Cells and Nuclei</i> .. .. .	326
HANSEMANN, D.— <i>Specific Character of Cell-divisions</i> .. .. .	326
DEMOOR, J.— <i>Physiology of the Cell</i> .. .. .	326
MINCHIN, E. A.— <i>Bütschli's Microscopic Foam and Protoplasm</i> .. .. .	437
BERNARD, H. M.— <i>Relations of Isotropous to Anisotropous Layers in Striped Muscles</i> .. .. .	437
BERGH, R. S.— <i>The Cell and the Animal Tissues</i> .. .. .	549
RATH, O. VOM.— <i>Number of Chromosomes in Animal-cells</i> .. .. .	549
HAECKER, V.— <i>Generative and Embryonic Mitoses</i> .. .. .	550
SCHAFFER, J.— <i>Histology and Histogenesis of Striped Muscle</i> .. .. .	550
MOORE, J. E. S.— <i>Archoplasm and Attraction Sphere</i> .. .. .	666
CHITTENDEN, R. H.— <i>Chemical Physiology of the Cell</i> .. .. .	666

### γ. General.

WENDT, G.— <i>Chemistry of Protoplasm</i> .. .. .	45
PICTET, R.— <i>Influence of Low Temperature</i> .. .. .	178
WERNER, F.— <i>Phenomena of Convergence</i> .. .. .	179
SCHIMKÉWITCH, W.— <i>Genetic Relations of Metazoa</i> .. .. .	327
JELLIFFE, S. E.— <i>Organisms in the Chicago Water Supply</i> .. .. .	328
WALLACE, A. R.— <i>Zoological Regions</i> .. .. .	437
FREDERICQ, L.— <i>Autotomy in the Animal Kingdom</i> .. .. .	438
HERDMAN.— <i>Zoology of Irish Sea</i> .. .. .	438
FREBAULT, A.— <i>Chemistry of Organisms</i> .. .. .	438
GARSTANG, W.— <i>Phylogeny of Chordata</i> .. .. .	438
KOCHS, W.— <i>Is there a Cell-life without Micro-organisms</i> .. .. .	551
HAACKE, W.— <i>Haacke's Theory of Gemmaria</i> .. .. .	551
KOSSEL, A., & A. NEUMANN.— <i>Disruption Products of Nuclein Acid</i> .. .. .	552
ZACHARIAS, O.— <i>Distribution of Lacustrine Plankton</i> .. .. .	552
BETHE, A.— <i>Function of Equilibration</i> .. .. .	666
RYDER, J. A.— <i>Correlations of the Volumes and Surfaces of Organisms</i> .. .. .	667

### B.—INVERTEBRATA.

MONTICELLI, F. S.— <i>Parasites of Holothurians of Naples</i> .. .. .	45
DANBY, W. H., & OTHERS.— <i>Natural History of British Columbia</i> .. .. .	328
ALCOCK, A.— <i>Deep-sea Invertebrates of Indian Ocean</i> .. .. .	439
GIARD, A.— <i>Dimorphism due to Parasitism</i> .. .. .	439
LAUTERBORN, R.— <i>Winter Fauna of the Upper Rhine</i> .. .. .	440
PLATEAU, F.— <i>False Mimicry</i> .. .. .	52

	PAGE
WALKER, J. J.— <i>Terrestrial Fauna of Damma Island, East Indian Archipelago</i> ..	552
STILES, C. W., & A. HASSALL— <i>Catalogue of Parasites</i> .. .. .	667
COUPIN, H.— <i>Food of two Commensals</i> .. .. .	667

### Mollusca.

FRENZEL, J.— <i>Histology of Mid-gut Gland</i> .. .. .	440
SMITH, E. A.— <i>Indian Deep-Sea Mollusca</i> .. .. .	668

#### a. Cephalopoda.

APPELLÖF, A.— <i>Cephalopoda of North Sea</i> .. .. .	45
PHISALIN, C.— <i>Inhibition in Cephalopoda</i> .. .. .	45
APPELLÖF, A.— <i>Bilateral Hectocotylization in Eledone cirrhosa</i> .. .. .	46
PERRIER, E., & M. A. T. DE ROCHEBRUNE— <i>Brooding Habits of Octopus Diguëti</i>	328
APPELLÖF, A.— <i>Shells of Sepia, Spirula, and Nautilus</i> .. .. .	553
JOUBIN, L.— <i>Cephalopoda of Amboina</i> .. .. .	554
RACOVITZA, E. G.— <i>Copulation of Cephalopoda</i> .. .. .	554
” ” <i>Fecundation of Octopus vulgaris</i> .. .. .	554
KORSCHULT— <i>Spawn and Embryos of Eledone</i> .. .. .	555

#### β. Pteropoda.

KNOWER, H. MCE.— <i>Pteropods with Two Separate Sexual Orifices</i> .. .. .	555
---	-----

#### γ. Gastropoda.

HALLER, B.— <i>Neotænioglossæ</i> .. .. .	46
COLLINGE, W. E.— <i>Absence of Male Reproductive Organs in Two Hermaphrodite</i>	
<i>Molluscs</i> .. .. .	46
BERGH, R.— <i>Doridiidæ</i> .. .. .	46
KÖHLER, A.— <i>Siphonaria</i> .. .. .	47
PLATE, L. H.— <i>The Oncidiidæ</i> .. .. .	47
METCALF, M. M.— <i>Embryology of Chiton</i> .. .. .	49
CARUS, J. V.— <i>Index to the Zoologischer Anzeiger</i> .. .. .	49
BERGH, R.— <i>Doridiidæ</i> .. .. .	179
” ” <i>The Genus Gastropteron</i> .. .. .	180
IHERING, H. VON— <i>Morphology of Sacoglossa</i> .. .. .	180
PELSENEER, P.— <i>Excretory and Reproductive Apparatus of Elysia</i> .. .. .	180
BOUTAN, L.— <i>Nervous System of Nerita and Navicella</i> .. .. .	181
PELSENEER, P.— <i>Shell Cavity of Philinidæ</i> .. .. .	182
GIROD, P.— <i>Kidney of Snail</i> .. .. .	182
BERGH, R.— <i>New Polyceræd</i> .. .. .	182
STERKI, V.— <i>Growth Changes of Radula in Land Mollusca</i> .. .. .	182
LOCARD— <i>Mollusca of Water Mains of Paris</i> .. .. .	182
COCKERELL, T. D. A., & W. E. COLLINGE— <i>Check-List of Slugs</i> .. .. .	183
OSWALD, A.— <i>Proboscis of Prosobranchs</i> .. .. .	328
TOURENG— <i>Nervous System of Dreissensia polymorpha</i> .. .. .	328
PLATE, L.— <i>Gadinia peruviana</i> .. .. .	329
ANDRÉ, E.— <i>Anatomy and Physiology of Ancyclus lacustris and A. fluviatilis</i> ..	329
SAMASSA, P.— <i>Nerves of Oculiferous Tentacle of Helix pomatia</i> .. .. .	440
HENKING, H.— <i>Hydrobia ulvæ</i> .. .. .	440
PLATE, L.— <i>Circulatory and Renal Organs of Chitons</i> .. .. .	440
KOFOID, C. A.— <i>Laws of Cleavage in Limax</i> .. .. .	555
ERLANGER, R. v.— <i>Primitive Nephridia of Lymnæus</i> .. .. .	556
IHERING, H. VON— <i>Peltella</i> .. .. .	556
PLATE, L.— <i>Renal and Circulatory Organs of Chitons</i> .. .. .	556
” ” <i>Oncidiella coquimbensis</i> .. .. .	556
SCHMIDT, F.— <i>Cleavage and Germ-Layer-Formation in Stylommatophora</i>	668
LACAZE-DUTHIERS— <i>Gonads of Ancyclus</i> .. .. .	668
GILCHRIST, J. D. F.— <i>Arrangement, Correlation, and Function of Pallial Organs of</i>	
<i>Tectibranchiata</i> .. .. .	669
CRAMPTON, H. E.— <i>Reversal of Cleavage in a Sinistral Gastropod</i> .. .. .	669
VARIGNY, H. DE— <i>Experimental Nanism</i> .. .. .	670

	PAGE
CUÉNOT, L.— <i>Function of Kidney of Helix</i> .. .. .	670
PELSENER, P.— <i>Branchiate Pulmonates</i> .. .. .	670
HALLER, B.— <i>Notes on Polyplacophora</i> .. .. .	670

### 3. Lamellibranchiata.

KNOLL, PH.— <i>Muscle-Fibres of Mollusca</i> .. .. .	49
STAUFFACHER, H.— <i>Oogenesis and Segmentation in Cyclas</i> .. .. .	330
NAGEL, W. A.— <i>Sense of Light in Eyeless Bivalves</i> .. .. .	441
TOURENG— <i>Circulatory System of Dreissensia polymorpha</i> .. .. .	442
WÖHRMANN, S. VON— <i>Systematic Position of Trigonidæ</i> .. .. .	556
KISHINOUE, K.— <i>Eyes of Cardium muticum</i> .. .. .	671

### Molluscoidea.

#### a. Tunicata.

SEELIGER, O.— <i>Origin of Peribranchial Cavity in Ascidian Embryos</i> .. .. .	50
"   " <i>Formation of Mantle</i> .. .. .	50
HERDMAN, W. A.— <i>British Tunicata</i> .. .. .	50
HEIDEN, H.— <i>Ascidians of Minorca</i> .. .. .	51
BORGERT, A.— <i>New Doliolum</i> .. .. .	51
METCALF, M. M.— <i>Eyes and Subneural Gland of Salpa</i> .. .. .	183
APSTEIN, C.— <i>Salpæ of Berlin Museum</i> .. .. .	183
TRAUSTEDT, M., & W. WELTNER— <i>Tunicata collected by Dr. Sander</i> .. .. .	183
WILLEY, A.— <i>Evolution of Præoral Lobe</i> .. .. .	330
CAULLERY— <i>Genital Products in Polyclinidæ</i> .. .. .	330
SALENSKY, W.— <i>Metamorphosis of Distaplia magnilarva</i> .. .. .	330
TODARO, F.— <i>Visual Organ of Salpa</i> .. .. .	331
SEELIGER, O.— <i>So-called Segmentation of the Tail in Appendicularia</i> .. .. .	442
CAULLERY— <i>Degeneration of Distaplia</i> .. .. .	442
LEFEVRE, G.— <i>Vertebration of Tail of Appendiculariæ</i> .. .. .	557
WARHAM, A. E.— <i>Variations in the Dorsal Tubercle of Ascidia virginea</i> .. .. .	557
CAULLERY, M.— <i>Budding of Diplosomidæ and Didemnidæ</i> .. .. .	671
GOTTSCHALDT, R.— <i>Synascidæ of Spitzbergen Expedition</i> .. .. .	671
RITTER, W. E.— <i>Perophora annectens</i> .. .. .	672

#### B. Bryozoa.

PROUHO, H., & E. EHLERS— <i>Contributions to our Knowledge of Polyzoa</i> .. .. .	183
DUERDEN, J. F.— <i>New and Rare Irish Polyzoa</i> .. .. .	185
VÁNGEL, E.— <i>Bryozoa of Hungary</i> .. .. .	442

### Arthropoda.

PERRIER, E.— <i>Arthropoda</i> .. .. .	51
HANSEN, H. J.— <i>Morphology of Crustacean and Insect Appendages</i> .. .. .	52
KINGSLEY, J. S.— <i>Classification of Arthropoda</i> .. .. .	331
DANA, J. D.— <i>Derivation and Homologies of some Articulates</i> .. .. .	442
DIXON, H. H.— <i>Walking of some Arthropoda</i> .. .. .	557
WAGNER, J.— <i>Germinal Layers, Yolk Cells, and Embryonic Membranes of Arthropoda</i> .. .. .	672

#### a. Insecta.

HAASE, C.— <i>Mimicry</i> .. .. .	52
PATRIZI, M. L.— <i>Muscular Action in Bombyx</i> .. .. .	52
AUERBACH, L.— <i>Spermatozoa of Dytiscus</i> .. .. .	52
VERHOEFF, C.— <i>Copulatory Organs of Male Hymenoptera</i> .. .. .	53
BORDAS— <i>Male Genital Apparatus of Hymenoptera</i> .. .. .	53
INGENITZKY, J.— <i>Copulatory Organs of Libellulidæ</i> .. .. .	53
LUCAS, R.— <i>Mouth-parts of Trichoptera</i> .. .. .	54
BOAS, J. E. V.— <i>Stigmata of Larva of Melolontha</i> .. .. .	54
CAMERANO, L.— <i>Respiratory Movements of Coleoptera</i> .. .. .	55
SCUDDER, S. H.— <i>Orthoptera of Galapagos</i> .. .. .	55
CHILD, C. M.— <i>Antennary Sensory Organs of Insects</i> .. .. .	185

	PAGE
URECH, F.— <i>Pigmentation in Scales of Lepidoptera and Coleoptera</i> .. .. .	186
THOMAS, M. B.— <i>Androconia of Lepidoptera</i> .. .. .	186
JOHANSEN, H.— <i>Development of Compound Eye of Vanessa</i> .. .. .	186
NOGAKUSHI, K. TOYAMA— <i>Spermatogenesis of Bombyx Mori</i> .. .. .	187
PACKARD, A. S.— <i>Life-history of Bombycine Moths</i> .. .. .	187
POULTON, E. B.— <i>Colours of Lepidopterous Larvæ</i> .. .. .	188
"    " <i>Sexes of Larvæ of Smerinthus populi</i> .. .. .	188
GRIFFITHS, A. B.— <i>Reproductive Organs of Noctua pronuba</i> .. .. .	188
HAMPSON, G. F.— <i>Indian Moths</i> .. .. .	189
BORDAS— <i>Salivary Glands of Hymenoptera</i> .. .. .	189
MARCHAL, P.— <i>Reproduction of Wasps</i> .. .. .	190
GRASSI, B., & A. SANDIAS— <i>Termite Societies</i> .. .. .	190
BRUYANT, CH.— <i>A Stridulating Aquatic Hemipteron</i> .. .. .	191
PEYTOUREAU— <i>Anatomy and Development of Female Genital Armature of Orthoptera</i> .. .. .	191
PEYTOUREAU, A.— <i>Anatomy and Development of Male Genital Armature of Lepidoptera</i> .. .. .	332
"    " <i>Female Genital Armature of Lepidoptera</i> .. .. .	332
EMERY, C.— <i>Evolution of the Worker-Caste among Ants</i> .. .. .	332
JANET, C.— <i>Production of Sound by Ants</i> .. .. .	334
"    " <i>Antennary Nerves and Chordotonal Organs in Ants</i> .. .. .	334
KÜNCKEL D'HERCULAIS, J.— <i>Hypermetamorphosis of Cantharidinæ</i> .. .. .	334
BORDAS— <i>Salivary Glands of Crabronidæ</i> .. .. .	334
"    " <i>Tracheal System of Larval Hymenoptera</i> .. .. .	334
GILSON, G.— <i>Formation of Silk</i> .. .. .	334
MALLOCK, A.— <i>Insect Sight and the Defining Power of Composite Eyes</i> .. .. .	443
DIXEY, F. A.— <i>Phylogeny of the Pierinæ</i> .. .. .	443
CHAPMAN, T. A.— <i>Notes on Micro-Lepidoptera</i> .. .. .	443
FRITZE, A.— <i>Seasonal Dimorphism and Polymorphism in Japanese Butterflies</i> .. .. .	444
KIRBY, W. F.— <i>Bees and Dead Carcasses</i> .. .. .	444
JANET, C.— <i>Glandular System of Ants</i> .. .. .	444
BORDAS— <i>Poison-Apparatus of Hymenoptera</i> .. .. .	445
"    " <i>Salivary Glands of Ichneumonidæ</i> .. .. .	445
CUÉNOT, L.— <i>Defensive Ejection of Blood</i> .. .. .	445
VISART, O.— <i>Alimentary Canal of Orthoptera</i> .. .. .	445
MITFORD, C. B.— <i>Flight of Locusts</i> .. .. .	445
KÜNCKEL D'HERCULAIS, J.— <i>Dipterous Parasites of Locusts</i> .. .. .	446
NIETSCHE, V.— <i>Tracheal System of Locusta</i> .. .. .	446
SCUDDER, S. H.— <i>Tertiary Tipulidæ</i> .. .. .	446
HEYMONS, R.— <i>Formation of Germinal Layers in Insects</i> .. .. .	557
ANDEREGG, E.— <i>Alternation of Generations in Insects</i> .. .. .	558
XAMBERN— <i>Metamorphoses of Insects</i> .. .. .	558
STANDFUSS, M.— <i>Relations between Colouring and Habit in Lepidoptera</i> .. .. .	558
SEITZ, AD.— <i>Reproduction in Butterflies</i> .. .. .	559
PACKARD, A. S.— <i>Transformations of Saturniidæ</i> .. .. .	559
PHISALIX, C.— <i>Red Pigment of Pyrrhocoris apterus</i> .. .. .	559
KNOWER, H. MCE.— <i>Origin of the "Nasutus" (Soldier) of Eutermes</i> .. .. .	560
WERNER, F.— <i>Alimentary Canal of Orthoptera</i> .. .. .	560
KÜNCKEL D'HERCULAIS, J.— <i>Oviposition in Acrididæ</i> .. .. .	560
"    "    " <i>Diptera Parasitic on Acrididæ</i> .. .. .	560
MERRIFIELD, F., & F. A. DIXEY— <i>Temperature Experiments on Lepidoptera</i> .. .. .	673
VERHOEFF, C.— <i>Comparative Morphology of Abdomen of Lampyridæ, Cantharidæ, and Malachiidæ</i> .. .. .	673
CAMERANO, L.— <i>Absolute Force of Muscles</i> .. .. .	673
ESCHERICH, K.— <i>Male Reproductive Organs of Beetles</i> .. .. .	673
SCUDDER, S. H.— <i>Tertiary Rhynchophorous Coleoptera of the United States</i> .. .. .	674
MARCHAL, P.— <i>Seminal Receptacle of the Wasp</i> .. .. .	674
"    "    " <i>Fertile Workers among Bees</i> .. .. .	674
"    "    " <i>Diptera destructive of Cereals</i> .. .. .	675
DREYFUS, L.— <i>Anatomy of Phylloxeridæ</i> .. .. .	675
KÖNIG, A.— <i>Larva of Oncodes</i> .. .. .	675
KOWALEVSKY, A.— <i>Heart of Orthoptera</i> .. .. .	675
LEWIS, R. T.— <i>Parasites on a Penguin</i> .. .. .	762



## β. Myriopoda.

	PAGE
VERHOEFF, C.— <i>Chordeuma germanicum</i> .. .. .	191
„ „— <i>Developmental Stages of Iulidæ</i> .. .. .	335
ADENSAMER, TH.— <i>Eyes of Scutigera coleoptrata</i> .. .. .	335
UNDERWOOD, L. M.— <i>Myriopoda of North America</i> .. .. .	447
SCHMIDT, P.— <i>Structure of Pauropus</i> .. .. .	447
VERHOEFF, C.— <i>Classification of Iulidæ</i> .. .. .	675
DUBOSCQ, O.— <i>Poison-Glands of Chilopoda</i> .. .. .	676

## γ. Protracheata.

DENDY, A.— <i>Hatching of a Peripatus Egg</i> .. .. .	191
POCOCK, R. I.— <i>Peripatus</i> .. .. .	561

## δ. Arachnida.

MICHAEL, A. D.— <i>Progress and Present State of our Knowledge of the Acari</i> .. .. .	18
SCHIMKEWITSCH, W.— <i>Endosternite of Arachnida</i> .. .. .	55
BERNARD, H. M.— <i>Stigmata of Arachnida</i> .. .. .	55
POCOCK, R. I.— <i>Instincts of Common English Spiders</i> .. .. .	55
BERNARD, H. M.— <i>Chernetidæ</i> .. .. .	56
WAGNER, W.— <i>Activity of Heart of Spiders</i> .. .. .	56
KARPELLES, L.— <i>Anatomy of Bdella arenaria</i> .. .. .	57
BERNARD, H. M.— <i>Endosternite of Scorpio</i> .. .. .	192
LAURIE, M.— <i>Anatomy and Relations of Eurypteridæ</i> .. .. .	192
SCHIMKEWITSCH, W. M.— <i>Pantopoda of Albatross Expedition</i> .. .. .	193
MICHAEL, A. D.— <i>Notes on the Uropodinae</i> .. .. .	289
PURCELL, F.— <i>Eyes of Harvestmen</i> .. .. .	335
LANCE, D.— <i>Revival of Tardigrades</i> .. .. .	335
BEECHER, C. E.— <i>Appendages of Pygidium of Triarthrus</i> .. .. .	335
PATTEN, W.— <i>Artificial Segmentation of Limulus</i> .. .. .	336
BERNARD, H. M.— <i>Lateral Eyes in Galeodidæ</i> .. .. .	447
SCHIMKEWITSCH, W.— <i>Endosternite of Arachnids</i> .. .. .	448
TROUËSSART, E.— <i>Parthenogenesis of Sarcoptidæ</i> .. .. .	448
PATTEN, W.— <i>Structures resembling Dermal Bones in Limulus</i> .. .. .	448
BERNARD, H. M.— <i>Vestigial Stigmata in Arachnida</i> .. .. .	561
JAWOROWSKI, A.— <i>Development of Pulmonary Sacs in Arachnids</i> .. .. .	561
PURCELL, F.— <i>Eye of Phalangidæ</i> .. .. .	562
CARPENTER, G. H.— <i>Irish Pycnogonida</i> .. .. .	562
BERNARD, H. M.— <i>Systematic Position of Trilobites</i> .. .. .	562
SIMONS, O. L.— <i>Development of Lungs of Spiders</i> .. .. .	676
KISHINOUE, K.— <i>Cælotomic Cavity of Spider</i> .. .. .	676
BRAUER, A.— <i>Development of Scorpion</i> .. .. .	677
TROUËSSART, E.— <i>Parthenogenesis in Plumicolous Sarcoptidæ</i> .. .. .	677

## ε. Crustacea.

PARKER, T. JEFFERY, & J. G. RICH— <i>Myology of Palinurus Edwardsi</i> .. .. .	57
BERGH, R. S.— <i>Germinal Area of Mysis</i> .. .. .	57
MRÁZEK, AL.— <i>Antennæ of Cyclopoidæ</i> .. .. .	58
SCHMEIL, O.— <i>The Genus Cyclops</i> .. .. .	58
CLAUS, C.— <i>The Pontellidæ</i> .. .. .	58
„ „— <i>New Observations on Cyclops</i> .. .. .	59
„ „— <i>Skeleton of Copepoda</i> .. .. .	59
BRAUER, A.— <i>Ovum of Branchipus</i> .. .. .	59
BRAEM, F.— <i>The Genus Apus</i> .. .. .	60
BRADY, G. S.— <i>Fucitrogus Rhodymenizæ, a Gall-producing Copepod</i> .. .. .	168
SABATIER, A.— <i>Spermatogenesis in Decapod Crustacea</i> .. .. .	193
CUËNOT, L.— <i>Physiology of Decapod Crustacea</i> .. .. .	194
WELDON, W. F. R.— <i>Correlated Variations in Carcinus Mænas</i> .. .. .	195
DENDY, A.— <i>Crayfish with Abnormal Appendages</i> .. .. .	195
BERGH, R. S.— <i>Shifting of the Germinal Streak in Gammarus</i> .. .. .	195



	PAGE
HAECKER, V.— <i>Winter and Summer Eggs of Moina</i> .. .. .	196
SAMASSA, P.— <i>Formation of Germinal Layers in Moina</i> .. .. .	196
GRUVEL, A.— <i>Buccal Apparatus of Cirripedia</i> .. .. .	196
HARDY, W. B., & W. MCDUGALL.— <i>Structure and Functions of Alimentary Canal of Daphnia</i> .. .. .	196
RACOVITZA— <i>Ascothoracida</i> .. .. .	197
BEECHER, C. E.— <i>Thoracic Legs of Triarthrus</i> .. .. .	198
CHUN, C.— <i>Luminous Organs and Compound Eyes</i> .. .. .	336
GROOM, T. T.— <i>Early Development of Cirripedia</i> .. .. .	337
AURIVILLIUS, C. W. S.— <i>Post-embryonic Development of Lepadidæ</i> .. .. .	338
BRAUER, A.— <i>Parthenogenesis of Artemia</i> .. .. .	339
SCHMEIL, O.— <i>Harpacticidæ</i> .. .. .	339
CUÉNOT, L.— <i>Physiology of Decapod Crustacea</i> .. .. .	449
BUMPUS, H. C.— <i>Median Eye of Adult Crustacea</i> .. .. .	449
THOMPSON, H.— <i>Correlation of certain External Parts of Palæmon serratus</i> .. .. .	449
LÖNNBERG, E.— <i>Blind Cambarus from Florida</i> .. .. .	450
THOMPSON, I. C.— <i>Copepoda of Liverpool Bay</i> .. .. .	450
GRUVEL, A.— <i>Cirripedia</i> .. .. .	450
ZEHNTNER, L.— <i>Crustacea of Malay Archipelago</i> .. .. .	563
ALLEN, E. J.— <i>Histology of Nervous System of Embryonic Lobster</i> .. .. .	563
BUTSCHINSKY, P.— <i>Development of Gebia littoralis</i> .. .. .	564
MILNE-EDWARDS, A., & E. L. BOUVIER— <i>Galatheidæ</i> .. .. .	565
BOUVIER, E. L.— <i>Lomisinæ</i> .. .. .	566
RACOVITSA, E. G.— <i>Habits of Pilumnus hirtellus</i> .. .. .	567
BELL, F. JEFFREY— <i>Thelphuzæ from Eastern Africa</i> .. .. .	567
SCOURFIELD, D. J.— <i>Entomostraca of Wanstead Park</i> .. .. .	567
PHILIPPI, R. A.— <i>European and Chilian Crustacea</i> .. .. .	677
HERRICK, F. H.— <i>Reproduction of Lobster</i> .. .. .	677
BOUVIER, E. L.— <i>Conversion of Pagurinæ into Lithodinæ</i> .. .. .	678
CHILTON, C.— <i>Subterranean Crustacea of New Zealand</i> .. .. .	678
ORTMANN, A.— <i>Pelagic Schizopoda</i> .. .. .	679
SARS, G. O.— <i>Caspian Crustacea</i> .. .. .	679
SCOTT, T.— <i>Entomostraca from Gulf of Guinea</i> .. .. .	680
MÜLLER, G. W.— <i>Ostracoda of Naples</i> .. .. .	680
CLAUS, C.— <i>Metamorphosis of Freshwater Ostracoda</i> .. .. .	681
ASTROUMOFF, A.— <i>A Flying Copepod</i> .. .. .	681

### Vermes.

LOEB, J.— <i>Cerebral Physiology of Worms</i> .. .. .	681
---	-----

### a. Annelida.

MALACQUIN, A.— <i>Researches on Syllidæ</i> .. .. .	60
MESNIL, F.— <i>Polydora</i> .. .. .	62
FRIEND, H.— <i>New Irish Earthworms</i> .. .. .	62
CROCKEWIT, J. M.— <i>Jaws of Hirudinea</i> .. .. .	62
LEUCKART, R.— <i>Infundibular Apparatus of Hirudinea</i> .. .. .	62
WHITMAN, C. O.— <i>Eye of Ctepsine</i> .. .. .	62
WAWRZIK, E.— <i>Supporting Tissues of Nervous System of Chætopoda</i> .. .. .	198
MCINTOSH, W. C.— <i>Tubes formed by Annelids</i> .. .. .	198
CARAZZI, D.— <i>The Genus Polydora</i> .. .. .	199
RACOVITZA, E. G.— <i>Amœbocytes and Oogenesis in Micronereis variegata</i> .. .. .	199
BUCHANAN, F.— <i>A Polymoid with Branchiæ</i> .. .. .	199
COLE, F. J.— <i>Clitellum of Earthworm</i> .. .. .	200
UDE, H.— <i>Exotic Earthworms</i> .. .. .	200
SPENCER, W. BALDWIN— <i>Victorian Earthworms</i> .. .. .	200
BEDDARD, F. E.— <i>South American Tubificidæ</i> .. .. .	200
HESSE, R.— <i>Structure of Enchytræidæ</i> .. .. .	201
BRAEM, F., & E. KORSCHULT— <i>Development of Ophryotrocha</i> .. .. .	340
SCHAEFFI, TH.— <i>Chloragogen of Ophelia radiata</i> .. .. .	341
MARENZELLER, E. VON— <i>Deep-sea Polychæta of Eastern Mediterranean</i> .. .. .	342
GIARD, A.— <i>New Phreorcytes</i> .. .. .	342

	PAGE
EISEN, G.— <i>Californian Eudrilidæ</i> .. .. .	342
HORST, R.— <i>Earthworms from the Congo</i> .. .. .	343
WILLIAMSON, H. C.— <i>Bijid Earthworm</i> .. .. .	343
GRAF, A.— <i>Excretory System of Nephelis</i> .. .. .	343
BLANCHARD, R.— <i>Leeches of the Iberian Peninsula</i> .. .. .	343
MOORE, J. PERCY— <i>Leech-like Parasites of American Crayfishes</i> .. .. .	343
BLANCHARD, R.— <i>Notes on Hirudinea</i> .. .. .	344
MCINTOSH, W. C.— <i>Structure of Euphrosyne</i> .. .. .	450
” ” <i>Young Stages of Magelona</i> .. .. .	451
BÉRANECK, E.— <i>Auditory Organs of Alciopidæ</i> .. .. .	451
WATSON, A. T.— <i>Habits of Amphiteuidæ</i> .. .. .	567
SMIRNOW, A.— <i>Free Nerve-endings in the Epithelium of the Earthworm</i> .. .. .	568
BEDDARD, F. E.— <i>Oligochæta of Eastern Tropical Africa</i> .. .. .	568
” ” <i>New Genera of Earthworms from Western Tropical Africa</i> .. .. .	569
BOURNE, A. G.— <i>Anatomy and Development of some Earthworms</i> .. .. .	569
” ” <i>Moniligaster</i> .. .. .	569
ST. JOSEPH, DE— <i>Polychæta of Dinard</i> .. .. .	682
HESSE, R.— <i>Septal Glands of Oligochæta</i> .. .. .	682
BEDDARD, F. E.— <i>New or little-known Oligochæta</i> .. .. .	683
ROSA, D.— <i>Revision of Lumbricidæ</i> .. .. .	683
MERRILL, H. B.— <i>Eye of Leech</i> .. .. .	683
BOLSJUS, H.— <i>Efferent Canal of Glossiphoniidæ</i> .. .. .	683
FISCHER, W.— <i>Gill-like Organs of Sipunculus</i> .. .. .	683

### β. Nematelminths.

BRAUER, A.— <i>Spermatogenesis in Ascaris megalocephala</i> .. .. .	63
HAMANN, O.— <i>Schneider's Pore and Esophageal Glands in Nematodes</i> .. .. .	63
REIBISCH, J.— <i>Trichosomum strumosum sp. n.</i> .. .. .	64
HAMANN, O.— <i>History of Filaria uncinata</i> .. .. .	64
JANET, C.— <i>Nematodes of Pharyngeal Glands of Ants</i> .. .. .	64
JANSON— <i>Filaria immittis in a Japanese Wolf</i> .. .. .	65
CERFONTAINE, P.— <i>Trichinosis</i> .. .. .	65
KAISER, J. E.— <i>Acanthocephala</i> .. .. .	65
SALA, L.— <i>Experiments with Ova of Ascaris</i> .. .. .	201
JÄGERSKIÖLD, L. A.— <i>Anatomy of Nematodes</i> .. .. .	202
COBB, N. A.— <i>Australian and Fijian Nematodes</i> .. .. .	202
CAMERANO, L.— <i>Notes on Gordii</i> .. .. .	344
COBB, N. A.— <i>New Genera of Nematodes</i> .. .. .	451
JÄGERSKIÖLD, L. A.— <i>Structure of Nematodes</i> .. .. .	452
LINSTOW, V.— <i>Heterakis Sorsinoi</i> .. .. .	452
GÖLDI, E.— <i>Nematode of Coffee-Disease</i> .. .. .	452
COBB, N. A.— <i>Nematodes and Sugar Cane</i> .. .. .	570
APÁTHY, S.— <i>Conducting Element in the Muscle-fibres of Ascaris</i> .. .. .	570
FONT Y TORNÉ— <i>Filariasis in Europe</i> .. .. .	570
SORSINO, P.— <i>Helminthological Notes</i> .. .. .	570
VEJDOVSKÝ, F.— <i>Development of Organs in Gordiidæ</i> .. .. .	684
GILSON, G., & J. PANTEL— <i>Muscular Cells of Ascaris</i> .. .. .	685
MUELLER, A.— <i>Helminthological Notes</i> .. .. .	685

### γ. Platyhelminthes.

REPIACHOFF, W.— <i>Spermatogenesis of Turbellaria</i> .. .. .	65
NOACK, E. J.— <i>Distomum clavigerum</i> .. .. .	65
HASWELL, W. A.— <i>Monograph of Temnocephalæ</i> .. .. .	65
” ” <i>Apparently New Type of Platyhelminth</i> .. .. .	66
WOODWORTH, W. M. M.— <i>Turbellaria of 'Albatross' Expedition</i> .. .. .	202
DENDY, A.— <i>Land Planarians from Tasmania and South Australia</i> .. .. .	202
PLESSIS, G. DU— <i>Emea lucustris</i> .. .. .	202
LINSTOW, V.— <i>Structure and Life-history of Tæniæ</i> .. .. .	203
BÜRGER, O.— <i>Developmental History of Nemertines</i> .. .. .	344
BERGENDAL, D.— <i>Polypostia similis</i> .. .. .	345
WARD, H. B.— <i>Distomum Westermanni in the United States</i> .. .. .	345

	PAGE
GOTO, SEITARO— <i>Canal of Laurer</i> .. .. .	345
STILES, C. W., & A. HASSALL— <i>Adult Cestodes of Cattle, Sheep, and Allied Animals</i> .. .. .	345
BRAUN, M.— <i>Cystic Worms of Bothriocephalus in German Fishes</i> .. .. .	346
WHEELER, W. M.— <i>Planocera inquilina</i> .. .. .	452
" <i>New Marine Triclad</i> .. .. .	453
GAMBLE, F. W.— <i>Turbellaria of Liverpool Marine District</i> .. .. .	454
BRAUN, M.— <i>Life-history of Holostomidæ</i> .. .. .	454
LINSTOW, V.— <i>Helminthological Notes</i> .. .. .	454
BRAUN, M.— <i>New Human Liver Fluke</i> .. .. .	454
KÖHLER, E.— <i>Valvular Apparatus in Excretory Vessels of Tæniæ</i> .. .. .	454
CHOLODKOVSKY, N.— <i>Tænia Brandii</i> .. .. .	455
HASWELL, W. A., & J. P. HILL— <i>Polycercus</i> .. .. .	455
JOUBIN, L.— <i>French Nemertinea</i> .. .. .	571
FAHRMANN, O.— <i>Turbellaria-Fauna of Basle</i> .. .. .	571
CERFONTAINE, P.— <i>New Tristomid</i> .. .. .	571
"    " <i>Striated Muscular Fibres in a Trematode</i> .. .. .	571
CHATIN, J.— <i>Development and Formation of Excretory Canals in Cercaria echinata</i> .. .. .	572
LÜHE, M.— <i>Anatomy of Tæniidæ</i> .. .. .	572
MONTICELLI, F. S.— <i>Ligula as Food in Italy</i> .. .. .	573
KELLER, J.— <i>Asexual Reproduction in Freshwater Turbellaria</i> .. .. .	685
GRAFF, L.— <i>Notes on Land Planarians</i> .. .. .	686
PLATE, L.— <i>Temnocephala chilensis</i> .. .. .	686
LOOSS, A.— <i>Monograph on Distomum</i> .. .. .	687
IJIMA, I., & T. KURIMOTO— <i>New Human Tape-Worm</i> .. .. .	687
LUTZ, A.— <i>Tænia nana and flavopunctata</i> .. .. .	687
PERRONCITO, E.— <i>Growth of Tænia mediocanellata</i> .. .. .	688

#### 5. Incertæ Sedis.

LAUTERBORN, R.— <i>Rotifers of the Rhine</i> .. .. .	67
IMHOFF, O. E.— <i>Alpine Rotifers</i> .. .. .	67
HOOD, J., & D. BRYCE— <i>New Rotifers</i> .. .. .	67
SPENGLER, J. W.— <i>Enteropneusta</i> .. .. .	203
RITTER, W. E.— <i>Larva of Balanoglossus</i> .. .. .	204
DIXON-NUTTALL, F. R., & J. HOOD— <i>Notes on Rotifers</i> .. .. .	346
HILL, J. P.— <i>Balanoglossus from New South Wales</i> .. .. .	455
MASTERMAN, A. T.— <i>Food of Sagitta</i> .. .. .	456
WHEELER, W. M.— <i>Protrandric Hermaphroditism in Myzostoma</i> .. .. .	456
BILFINGER, L.— <i>Rotifera of Württemberg</i> .. .. .	456
MORGAN, T. H.— <i>Development of Balanoglossus</i> .. .. .	573
LEVANDER, K. M.— <i>Pedalion</i> .. .. .	574
JENNINGS, H. S.— <i>Rotatoria of Michigan</i> .. .. .	574

#### Echinoderma.

GRIEG, J. A.— <i>Ophiuroids of North Sea</i> .. .. .	67
MORTENSEN, T.— <i>Ophiopus arcticus</i> .. .. .	67
BATHER, F. A.— <i>Silurian Crinoids</i> .. .. .	68
STÜRTZ, B.— <i>Recent and Fossil Starfishes</i> .. .. .	204
PERRIER, E.— <i>Asteroidæ of the 'Travailleur' and 'Talisman' Expedition</i> .. .. .	205
FRENZEL, J.— <i>Enteric Canal of Echinoderma</i> .. .. .	206
MACBRIDE, E. W.— <i>Organogeny of Asterina gibbosa</i> .. .. .	206
GARSTANG, W.— <i>Bipinnaria from the English Channel</i> .. .. .	207
MARENZELLER, E. VON— <i>Holothurians of North Atlantic</i> .. .. .	207
HERBST, C., & OTHERS— <i>Experimental Embryology illustrated by Echinoderms</i> .. .. .	346
MARENZELLER, E. V.— <i>Deep-Sea Echinoderms of Eastern Mediterranean</i> .. .. .	348
LORIOU, P. DE— <i>Echinoderms of the Bay of Amboyna</i> .. .. .	349
"    " <i>Ophiuroids of Mauritius</i> .. .. .	349
CAPELLINI, G.— <i>Rhizocrinus Santagatai</i> .. .. .	349
MORTENSEN, T.— <i>Anatomy and Development of Cucumaria glacialis</i> .. .. .	456
KISHINOUE, K.— <i>Development of a Holothurian Spicule</i> .. .. .	457
CHADWICK, H. C.— <i>Haemal and Water-vascular Systems of Asteroidæ</i> .. .. .	574

	PAGE
BELL, F. JEFFREY— <i>Echinoderms of Eastern Seas</i> .. .. .	688
ALCOCK, A.— <i>Illustrations of Indian Echinoderms</i> .. .. .	689
LUDWIG, H.— <i>Asteroidea</i> .. .. .	689
CLARK, W. B.— <i>Mesozoic Echinoderma of the United States</i> .. .. .	689

## Cœlentera.

GOETTE, A.— <i>Development of Pelagia</i> .. .. .	69
LANKESTER, E. RAY— <i>Reappearance of Limnocoedium Sowerbii</i> .. .. .	69
FOWLER, G. H.— <i>Octineon Lindahli</i> .. .. .	208
DUERDEN, J. E.— <i>Irish Hydroids</i> .. .. .	208
BALE, W. M.— <i>Australian Hydroids</i> .. .. .	209
CHAPEAU, MARCELLIN— <i>Digestion of Cœlentera</i> .. .. .	350
CARLGREN, O.— <i>Minyadæ</i> .. .. .	350
STUDER, T.— <i>Aleyonaria of the Albatross</i> .. .. .	350
CLARKE, S. F.— <i>Hydroids of the Albatross</i> .. .. .	351
GÜNTHER, R. T.— <i>Minute Anatomy of Limnocoedium</i> .. .. .	351
GUERNE, J. DE— <i>Freshwater Medusa from the Niger</i> .. .. .	351
OSBORN, H. L., & C. W. HARGITT— <i>Perigonimus</i> .. .. .	351
KOCH, G. V.— <i>Asexual Reproduction of Madrepora</i> .. .. .	457
LACAZE-DUTHIERS, H. DE— <i>Flabellum anthophyllum</i> .. .. .	457
BOURNE, G. C.— <i>Post-embryonic Development of Fungia</i> .. .. .	458
WILLEM, V.— <i>Structure of Tentacles of Apolemia uvaria</i> .. .. .	459
DAVENPORT, C. B.— <i>Regeneration in Obelia</i> .. .. .	459
GÜNTHER, R. T.— <i>Limnocoenida tanganyicæ</i> .. .. .	460
BEAUMONT, W. L.— <i>Lucernaria of Port Erin</i> .. .. .	460
HEIDER, K.— <i>Gastrodes</i> .. .. .	575
MAAS, O.— <i>Craspedote Medusæ of the Plankton</i> .. .. .	575
FOWLER, G. H.— <i>New Veretillid</i> .. .. .	576
BUNTING, M.— <i>Origin of Sex-cells in Hydractinia</i> .. .. .	576
HICKSON, S. J.— <i>Revision of Aleyonaria Stolonifera</i> .. .. .	690
BOURNE, G. C.— <i>Heliopora cærulea</i> .. .. .	690
PHILIPPI, R. A.— <i>Callirhabdos</i> .. .. .	691
LANG, A.— <i>Budding of Hydroids</i> .. .. .	691

## Porifera.

WELTNER, W.— <i>Studies on Spongillidæ</i> .. .. .	69
SCHULZE, F. E.— <i>Revision of Hyalonematidæ</i> .. .. .	70
MAAS, O.— <i>Development of Cornacuspongiæ</i> .. .. .	209
LENDENFELD, R. VON— <i>Systematic Position of Placospongia</i> .. .. .	210
SCHULZE, F. E.— <i>Hexactinellid Spicules</i> .. .. .	352
TOPSENT, E.— <i>New Sponges</i> .. .. .	352
MINCHIN, E. A., & H. V. WILSON— <i>Embryology of Porifera</i> .. .. .	461
MASTERMAN, A. T.— <i>Nutritive and Excretory Processes in Porifera</i> .. .. .	461
DENDY, A.— <i>Comparative Anatomy of Sponges</i> .. .. .	461
HANITSCH, R.— <i>Generic Nomenclature of Bowerbank's British Sponges</i> .. .. .	576
VOSMAER, G. C. J.— <i>Tetractinellidæ of Naples</i> .. .. .	691
IJIMA, I.— <i>New Hexactinellids from Sagami Bay</i> .. .. .	691

## Protozoa.

VERWORN, M.— <i>Physiological Significance of Cell-nucleus</i> .. .. .	70
SASSAKI, C.— <i>A New Heliozoon</i> .. .. .	70
RÖMER, F.— <i>A New Vorticella</i> .. .. .	71
SCHEWIAKOFF, W.— <i>Parasites of Cyclopidæ</i> .. .. .	71
POUCHET, G.— <i>Polymorphism of Peridinium acuminatum</i> .. .. .	71
MINGAZZINI— <i>Classification of Sporozoa</i> .. .. .	71
FLEXNER, S.— <i>Amœbæ in Abscess of Jaw</i> .. .. .	72
THÉLOHAN, P.— <i>Muscle Degeneration in Barbel from presence of Myxosporidia</i> .. .. .	72
BERTRAM, A.— <i>Sarcosporidia of the Gecko, Sheep, and Swine</i> .. .. .	72
PETERSEN, W.— <i>Psorosperms of Darier's Disease</i> .. .. .	73
CHAPMAN, F.— <i>Foraminifera of the Gault of Folkstone</i> .—V. .. .. .	153
BLOCHMANN, F.— <i>Studies on Protozoa</i> .. .. .	210



	PAGE
GRUBER, A.— <i>Microscopic Vivisection</i> .. .. .	210
LINDER— <i>Parasitic Vorticellæ</i> .. .. .	211
WILLACH, P.— <i>Balantidium viride</i> , an Infusorian Pathogenic to Pigeons .. .. .	211
SCHAUDINN, F.— <i>Myxotheca arenilega</i> .. .. .	212
LEGER, L.— <i>New Gregarine in Algerian Acrididæ</i> .. .. .	212
DANGEARD, P. A.— <i>Polysporella</i> .. .. .	212
EPSTEIN, A.— <i>Monocercomonas Hominis and Amœba coli</i> .. .. .	212
MASSARI, G., & E. FERRONI— <i>Supposed Cancer Parasites</i> .. .. .	213
PAWLOWSKY, A. D.— <i>Parasitic Cell-Inclusions in Sarcomatous Tissue</i> .. .. .	213
GRENFELL, J. G.— <i>Dicymida</i> .. .. .	287
SCHEWIAKOFF, W.— <i>So-called Excretory Granules of Infusorians</i> .. .. .	352
GREENWOOD, M.— <i>Food-vacuoles of Infusoria</i> .. .. .	353
SCHAUDINN, F.— <i>Reproduction of Foraminifera</i> .. .. .	353
EGGER, J. G.— <i>Foraminifera of the Gazelle</i> .. .. .	354
SHERBORN, C. DAVIES— <i>Index to Foraminifera</i> .. .. .	354
MASSART, J.— <i>Irritability of Noctiluca</i> .. .. .	354
CELLI, A., & R. FIOCCA— <i>Amœbæ and their Cultivation</i> .. .. .	354
THÉLOHAN, P.— <i>Interrelations of Myxosporidia</i> .. .. .	355
PODYSZOSZKY, W.— <i>Development of Coccidium oviforme in Bile-duct of Rabbits</i> .. .. .	355
KURLOFF, M.— <i>Parasite of Skin Cancer</i> .. .. .	355
SAWTSCHENKO— <i>Cancer Parasite</i> .. .. .	356
SAKHAROFF, N.— <i>Influence of Cold on Vitality of Malaria Parasites</i> .. .. .	357
” ” <i>Hæmatozoa of Birds</i> .. .. .	357
DANILEWSKY, W.— <i>Hæmatozoa in Animals</i> .. .. .	358
SHRUBSOLE, W. H.— <i>Gromia; Lieberkuhnia; “Foul-water” or “May-water”</i> .. .. .	418
CHAPMAN, F.— <i>Foraminifera of the Gault of Folkestone</i> .—VI. .. .. .	421
GREENWOOD, M., & SAUNDERS, E. R.— <i>Rôle of Acid in Protozoan Digestion</i> .. .. .	462
LEVANDER, K. M.— <i>Protozoa of Helsingfors</i> .. .. .	462
WASSILIEWSKI— <i>Protozoa in Herpes Zoster</i> .. .. .	462
ROOS, E.— <i>Infusoria of Diarrhea</i> .. .. .	463
BLOCHMANN, F.— <i>Dimorpha mutans</i> .. .. .	463
GOULD, L. J.— <i>Minute Structure of Pelomyxa palustris</i> .. .. .	463
ISHIKAWA, C.— <i>Nuclear Division in Noctiluca</i> .. .. .	464
RHUMBLER, L.— <i>Enclosure of Globigerina by Orbulina</i> .. .. .	464
GURLEY, R. R.— <i>Classification of Myxosporidia</i> .. .. .	465
THÉLOHAN, P.— <i>Spores of Microsporidia</i> .. .. .	465
LÉGER, L.— <i>New Genus of Gregarines</i> .. .. .	466
SAKHAROFF— <i>Structure of Nucleus of Crescentiform Bodies of Malaria</i> .. .. .	466
JOHNSON, H. P.— <i>Plastogamy of Actinosphærium</i> .. .. .	577
DE AMICIS, G. A.— <i>Pliocene Foraminifera</i> .. .. .	577
BLOCHMANN, F., & KEUTEN— <i>Nuclear Division in Euglena</i> .. .. .	577
BOSANQUET, W. C.— <i>Gregarine of Lunibricus herculeus</i> .. .. .	577
GUILLEBEAU, A.— <i>Coccidium in Cattle</i> .. .. .	577
LABBÉ, A.— <i>Endoglobular Parasites of Blood of Vertebrates</i> .. .. .	578
FRANCÉ, RAOUL— <i>Polytomæ</i> .. .. .	579
LEVANDER, K. M.— <i>Chain-forming Peridinium</i> .. .. .	580
FISCHER, A.— <i>Flagella</i> .. .. .	580
KAHANE, M.— <i>Living Parasites in the Blood of Cancerous Persons</i> .. .. .	580
CHAPMAN, F.— <i>The Foraminifera of the Gault of Folkestone</i> .—VII. .. .. .	645, 763
PRZESMYCKI, M.— <i>Cell-granules in Protozoa</i> .. .. .	691
RITTER, W. E.— <i>Parasite of Perophora annectens</i> .. .. .	692
LINDNER— <i>Morbific Effect of certain Vorticellæ</i> .. .. .	692
RYDER, J. A.— <i>Growth of Euglena confined to two dimensions of space</i> .. .. .	692
ISHIKAWA, C.— <i>Reproduction of Noctiluca miliaris</i> .. .. .	693
CELLI, A., & R. FIOCCA— <i>Classification of Amœbæ</i> .. .. .	694
” ” <i>The Life of Amœbæ</i> .. .. .	694
LISTER, J.— <i>Life-History of Foraminifera</i> .. .. .	694
RHUMBLER, L., & W. ZOPF— <i>Saccamina</i> .. .. .	695
LABBÉ, A.— <i>Double Coccidian Infection</i> .. .. .	696
ROOS & QUINCKE— <i>Amœba-Enteritis</i> .. .. .	696
DORIA, T. R.— <i>Protozoa in Endometritis</i> .. .. .	696
MARCHAND, F., & K. MIURA— <i>Trichomonas in Urine of Men</i> .. .. .	697

	PAGE
RUFFER, M. A., & OTHERS— <i>Parasite of Vaccinia and Variola</i> .. .. .	697
GUEYNATZ & PETROFF— <i>Parasites of Sarcoma</i> .. .. .	698
FOÀ, P., & OTHERS— <i>Parasites of Cancer</i> .. .. .	698
NITSCHÉ, P., & W. WELTNER— <i>Tetranitus Nitschei, a Parasite of Goldfish</i> .. .. .	699
BASTIANELLI & BIGNAMI— <i>Structure of the Malaria Parasites of the Summer and Autumn Fevers</i> .. .. .	700
GRIMM— <i>Protozoa in Abscess of Lung and Liver</i> .. .. .	700

## BOTANY.

## A. GENERAL, including the Anatomy and Physiology of the Phanerogamia.

## a. Anatomy.

## (1) Cell-structure and Protoplasm.

FARMER, J. B.— <i>Nuclear Division in the Pollen-mother-cells of Liliun Martagon</i> ..	74
BIELIAJEW, W.— <i>Karyokinesis in Pollen-mother-cells of Larix</i> .. .. .	74
RACIBORSKI, M.— <i>Nucleus of Germinating Seeds</i> .. .. .	74
WAHRLICH, W.— <i>Anatomy of the Cell in Fungi and Filiform Algae</i> .. .. .	74
MANGIN, L.— <i>Pectic Substances in Tissues</i> .. .. .	75
ZIMMERMANN, A.— <i>Silicified Thickening of Cell-wall</i> .. .. .	75
" <i>Cell-structure</i> .. .. .	214
CORRENS, C.— <i>Internal Structure of the Cell-wall</i> .. .. .	215
GILSON, E.— <i>Crystallization of Cellulose and Chemical Structure of the Cell-wall</i> ..	215
SCHULZE, E.— <i>Chemistry of the Cell-wall</i> .. .. .	216
KNY, L.— <i>Formation of Folds in Cell-walls</i> .. .. .	216
CORRENS, C.— <i>Transverse Lamellation of the Membrane of Bast-cell</i> .. .. .	216
KLEMM, P., & T. BOKORNY— <i>Aggregation of Protoplasm</i> .. .. .	359
CRATO, E.— <i>Physodes</i> .. .. .	359
SCHNEIDER, A.— <i>Plasomes</i> .. .. .	360
KARSTEN, G.— <i>Nucleoles and Centrosomes in Psilotum</i> .. .. .	360
WILDEMAN, E. DE— <i>Formation of Cell-walls</i> .. .. .	360
RIMPACH, A.— <i>Waviness of the Cell-wall of the Exoderm of Roots</i> .. .. .	360
DEMOOR, J.— <i>Independence of the Nucleus and the Cytoplasm</i> .. .. .	467
ELLIOTT, L. B.— <i>Karyokinesis</i> .. .. .	467
MANGIN, L.— <i>Structure of the Cell-wall</i> .. .. .	467
ZIMMERMANN, A.— <i>Growth of the Cell-wall</i> .. .. .	467
RACIBORSKI, M.— <i>Development of Elaioplasts in the Liliaceæ</i> .. .. .	467
ZIMMERMANN, A.— <i>Proteinaceous Crystalloids</i> .. .. .	468
STRASBURGER, E.— <i>Centrospheres of the Nucleus and Size of Cells</i> .. .. .	581
FARMER, J. B., & J. REEVES— <i>Centrospheres in the Spores of Pellia</i> .. .. .	581
ZIMMERMANN, A.— <i>Function of the Nucleus</i> .. .. .	582
ZACHARIAS, E.— <i>Growth of the Cell and Nature of the Nucleus</i> .. .. .	582
ZIMMERMANN, A.— <i>Behaviour of the Nucleoles during Karyokinesis</i> .. .. .	583
HUMPHREY, J. E.— <i>Nucleoles and Centrosomes</i> .. .. .	583
SCHULZE, E.— <i>Chemistry of the Cell-wall</i> .. .. .	583
SCHIPS, K.— <i>Cuticular Formations</i> .. .. .	584
ZIMMERMANN, A.— <i>Eye-spot</i> .. .. .	701
"    " <i>Cilia and Pseudo-cilia</i> .. .. .	701
DANGEARD, P. A., & LÉGER— <i>Structure of the Nucleus in Mucorini</i> .. .. .	701

## (2) Other Cell-contents (including Secretions).

SPATZIER, W.— <i>Myrosin in Plants</i> .. .. .	76
BELZUNG, E.— <i>Sphero-crystals of Euphorbia</i> .. .. .	76
ZIMMERMANN, A.— <i>Elaioplasts</i> .. .. .	76
WINTERSTEIN, E.— <i>Vegetable Amyloid</i> .. .. .	76
RACIBORSKI, M.— <i>Contents of the Trichomes of Myriophyllum</i> .. .. .	76
GAIN, E.— <i>Colouring Matters of Underground Organs</i> .. .. .	77
ZIMMERMANN, A.— <i>Excretions of Calcium Phosphate</i> .. .. .	77



	PAGE
BÜTSCHLI, O.— <i>Structure of Starch-grains</i> .. .. .	217
FLEURENT, E.— <i>Composition of Vegetable Albuminoids</i> .. .. .	217
SAPOSHNIKOFF, W.— <i>Accumulation of Carbohydrates in Leaves</i> .. .. .	217
TANRET, C.— <i>Inulin and its Allies</i> .. .. .	217
GIESSLER, R.— <i>Distribution of Oxalic Acid in Plants</i> .. .. .	217
GUIGNARD, L.— <i>Localization of the Active Principles in the Capparidææ, Tropæoleæ, Limnanthææ, and Resedacææ</i> .. .. .	218
FERMI, C., & L. PernoSSI— <i>Enzymes</i> .. .. .	360
BRAEMER, L.— <i>Localization of the Active Principles of the Cucurbitacææ</i> .. .. .	361
TONI, G. B. DE— <i>Localization of Nicotine in the Tobacco-plant</i> .. .. .	361
REINITZER, F.— <i>Fatigue-Substances</i> .. .. .	361
MESNARD, E.— <i>Localization of Fatty Oils in the Formation of Seeds and Fruits</i> .. .. .	468
GUIGNARD, L.— <i>Active Principles of the Papayacææ</i> .. .. .	468
MOLISCH, H.— <i>Indican</i> .. .. .	469
KRISTELLI, SCHRÖTTER V.— <i>Pigment of the Aril</i> .. .. .	469
DEMOUSSY— <i>Nitrates in Living Plants</i> .. .. .	469
ZIMMERMANN, A.— <i>Chromatophores</i> .. .. .	584
FAMINTZIN, A., & E. BELZUNG— <i>Chlorophyll-grains in Seeds and Seedlings</i> .. .. .	584
MONTEVERDE, N.— <i>Absorption-spectrum of Chlorophyll</i> .. .. .	701
SCHUNCK, E.— <i>Chemistry of Chlorophyll</i> .. .. .	702
ETARD, A.— <i>Occurrence of several Chlorophylls in the same Plant</i> .. .. .	702
MESNARD, E.— <i>Formation and Localization of Fatty and Essential Oils</i> .. .. .	702
CHAUTRIAU, G.— <i>Localization of Alkaloids</i> .. .. .	703
MIELKE, G.— <i>Formation and Function of Tannins</i> .. .. .	703
ZIMMERMANN, A.— <i>Elaïoplasts and Elaïospheres</i> .. .. .	704
RE, L.— <i>Spherocrystals of Agave</i> .. .. .	704
NEUMEISTER, R.— <i>Proteolytic Ferments in Seedlings</i> .. .. .	704
BELZUNG, E.— <i>Calcium Oxalate in Solution</i> .. .. .	704

## (3) Structure of Tissues.

JOST, L.— <i>Relationship between Leaf-development and the Formation of Vessels</i> .. .. .	77
WIELER, A.— <i>Stoppages of Vessels</i> .. .. .	77
GROOM, P.— <i>Aleurone-layer in the Seed of Grasses</i> .. .. .	78
MANGIN, L.— <i>Mucilage-layer in Flax-seeds</i> .. .. .	78
MATSUDA, S.— <i>Anatomy of Magnoliacææ</i> .. .. .	78
QUEVA, C.— <i>Anatomy of the Stem of Dioscoreacææ</i> .. .. .	78
RITTERSCHAUSEN, P.— <i>Anatomy of the Acalypheææ</i> .. .. .	78
ENGLER, A.— <i>Icacinacææ</i> .. .. .	79
WARBURG, O.— <i>Influence of Lignification on the Life of the Cell</i> .. .. .	211
HARTIG, R.— <i>Characteristics of Duramen</i> .. .. .	218
ZIMMERMANN, H.— <i>Comparison of Duramen and Albuminum</i> .. .. .	218
FLOT, L.— <i>Internal Pericycle</i> .. .. .	219
WALLICZEK, H.— <i>Mucilage of the Membrane of Vegetative Organs</i> .. .. .	219
HOULBERT, C.— <i>Secondary Wood of the Apetalææ</i> .. .. .	229
DANGEARD, P. A.— <i>Seedlings of Coniferææ</i> .. .. .	220
CORDEMOY, H. J. DE— <i>Root of Arborescent Liliacææ</i> .. .. .	220
HEIDEN, H., & C. HOLTERRMANN— <i>Anatomy of Combretacææ</i> .. .. .	221
GILG, E.— <i>Anatomy of Afromendoncia and Mendoncia</i> .. .. .	221
FLOT, L.— <i>Perimedullary Zone</i> .. .. .	361
SOHNKE, H.— <i>Flexibility of the Stem of Climbing Plants</i> .. .. .	362
TIEGHEM, P. VAN— <i>Structure of Thymelacæææ and Peneacæææ</i> .. .. .	362
WEYLANDT, J.— <i>Anatomy of Galegæææ</i> .. .. .	362
QUEVA, C.— <i>Anatomy of Atacciaææ</i> .. .. .	362
SABLON, LECLERC DU— <i>Anatomy of the Stem of Wistaria sinensis</i> .. .. .	363
SONNTAG, P.— <i>Connection between Lignification, Firmness, and Elasticity in Cell-walls</i> .. .. .	469
PETERSEN, O. G.— <i>Increase in Thickness of the Stem of Monocotyledons</i> .. .. .	469
LESAGE, P.— <i>Palisade-cells and Transpiration</i> .. .. .	470
HERBST, A.— <i>Medullary Rays of Dicotyledonous Herbs and Shrubs</i> .. .. .	470
MER, E.— <i>Witch-broom of the Fir</i> .. .. .	470

	PAGE
AVETTA, C.— <i>Cystoliths of Coccinia</i> .. .. .	471
SOLEREDER, H.— <i>Anatomy of Rubiaceæ</i> .. .. .	471
GOEBEL, K.— <i>Structure of Aquatic Plants</i> .. .. .	585
SCHILLING, A. J.— <i>Formation of Mucilage by Aquatic Plants</i> .. .. .	585
GODFRIN, J.— <i>Resin-canals in Abies pectinata</i> .. .. .	585
MANGIN, L.— <i>Muciferous and Resiniferous Cells in the Yew</i> .. .. .	586
WILCOX, E. M., & E. W. OLIVE— <i>Histology of Pontederia</i> .. .. .	586
SCHRENK, H.— <i>Parasitism of Epiphegus</i> .. .. .	586
KÜSTENMACHER, M.— <i>Structure and Composition of Galls</i> .. .. .	586
SCHNEIDER, A.— <i>Root-tubercles of Leguminosæ</i> .. .. .	586
MACDOUGAL, D. T.— <i>Root-tubercles of Isopyrum</i> .. .. .	587
JAHN, E.— <i>Wood and Pith at the bounds of the Annual Growth</i> .. .. .	704
MICHEELS, H.— <i>Fruit-bearing Axis of Palms</i> .. .. .	705
ROULET, C.— <i>Anatomy of the Stem of Thunbergia</i> .. .. .	705

(4) Structure of Organs.

REICHE, K.— <i>Anatomical Characters of Cæspitose Plants</i> .. .. .	79
GOEBEL, K.— <i>Insectivorous Plants</i> .. .. .	79
TOGNINI, F.— <i>Female Flower and Fruit of the Chestnut</i> .. .. .	79
MAYOUC, MDLLE.— <i>Staminal Appendages of Aristolochia</i> .. .. .	80
CELAKOVSKY, L.— <i>Stigmatic Lobes of Iris</i> .. .. .	80
" <i>Cupule of Quercus</i> .. .. .	80
KAYSER, G.— <i>Development of the Seed</i> .. .. .	80
GUIGNARD, L.— <i>Development of the Seed and of its Integument</i> .. .. .	81
SHIPS, K., & OTHERS— <i>Cuticle of the Seeds of Papilionaceæ</i> .. .. .	81
STAHL, E.— <i>Protection of Leaves against Excessive Rainfall</i> .. .. .	82
BALDACCI, A.— <i>Branching of Borraginaceæ and Apocynaceæ</i> .. .. .	82
PEIRCE, G. J.— <i>Haustoria of Phanerogamic Parasites</i> .. .. .	82
QUEVA, C.— <i>Bulbils of Dioscoreaceæ</i> .. .. .	83
NYPPEL— <i>Tubers of Apios tuberosa and Helianthus tuberosus</i> .. .. .	83
ANDOUARD, A.— <i>Development of Arachis</i> .. .. .	83
MEEHAN, T.— <i>Female Catkins in Populus</i> .. .. .	222
HUTCHCOCK, A. S.— <i>Opening of the Buds of Woody Plants</i> .. .. .	222
REINCKE, F.— <i>Vernation in the Compositæ, Campanulaceæ, and Lobeliaceæ</i> .. .. .	222
LOTHELIER, A.— <i>Spiny Plants</i> .. .. .	222
CANDOLLE, C. DE— <i>Comparative Anatomy of Leaves</i> .. .. .	222
ROSS, H.— <i>Leaves of Iridææ</i> .. .. .	222
HOLLE, G.— <i>Anatomy of the Leaves of Sapotaceæ</i> .. .. .	223
LIGNIER, O.— <i>Venation of Cycas</i> .. .. .	223
KNY, L.— <i>Laticiferous Hairs of the Cichoriaceæ</i> .. .. .	223
WARMING, E.— <i>Anatomy of Vellosiaceæ</i> .. .. .	223
DROHNIG, M.— <i>Root-tubers</i> .. .. .	223
RECHINGER, C.— <i>Divisibility of Organs</i> .. .. .	363
VUILLEMIN, P.— <i>Spurs of Tropæolum and Pelargonium</i> .. .. .	363
JACK, J. G.— <i>Fructification of Juniperus</i> .. .. .	363
LIGNIER, O.— <i>Fruit of Bennettites</i> .. .. .	363
CELAKOVSKY, L.— <i>Navel of the Apophyse of the Fruit-scales of Pinus</i> .. .. .	364
MACFARLANE, J. M.— <i>Pitched Insectivorous Plants</i> .. .. .	364
KOCH, L.— <i>Vegetative Branching</i> .. .. .	364
HOHENAUER, F.— <i>Stem of Grasses</i> .. .. .	365
LOTSY, J. P.— <i>Knees of Taxodium distichum</i> .. .. .	365
HEINIG, R. L.— <i>Blind Root-suckers of Swamp-forests</i> .. .. .	365
MÜLLER, J.— <i>Succulent Compositæ</i> .. .. .	365
HARSBERGER, J. W.— <i>Anatomy of Maize</i> .. .. .	366
BRAND, F.— <i>Leaves of Nymphæaceæ</i> .. .. .	366
SAUVAGEAU, C.— <i>Leaf of Butomaceæ</i> .. .. .	366
IHERING, R. v.— <i>Fall of Leaves</i> .. .. .	366
LINSBAUER, L.— <i>Stipules of Euonymus</i> .. .. .	366
PENZIG, O., & A. NESTLER— <i>Pearl-glands</i> .. .. .	367
NICHOLS, M. A.— <i>Achenial Hairs of Compositæ</i> .. .. .	367
WIDENMANN, VON— <i>Hairs of Tilia argentea</i> .. .. .	367
CLOS, D.— <i>Classification of Tubers</i> .. .. .	367

	PAGE
CHATIN, A.— <i>Variety and Localization of Organs as Evidence of Gradation</i> .. .. .	471
SCHENCK, H.— <i>Young Form of Gymnosperms</i> .. .. .	471
GOLENKIN, M.— <i>Inflorescence of Urticaceæ and Moraceæ</i> .. .. .	472
KLEIN, J.— <i>Structure of the Flower of Crucifera</i> .. .. .	472
SCHUMANN, K.— <i>Development of the Flowers of Crocus</i> .. .. .	472
ČELAKOVSKY, L.— <i>Cladodes of the Asparagææ</i> .. .. .	472
MEISSNER, R.— <i>Size of the Leaves of Conifers</i> .. .. .	472
TONKOFF, W.— <i>Swellings on the Leaf-stalk of Atragene</i> .. .. .	473
MEINEKE, E. P.— <i>Aerial Roots of Orchidææ</i> .. .. .	473
TIEGHEM, P. VAN— <i>Root of Parasitic Loranthaceæ</i> .. .. .	473
CAVARA, F.— <i>Male Flowers of the Box</i> .. .. .	587
MÜLLER, LUISE— <i>Anatomy of Petals</i> .. .. .	587
RACIBORSKI, M.— <i>Morphology of the Cabombaceæ and Nymphæaceæ</i> .. .. .	588
SCHMID, R.— <i>Embryo of Phanerogams</i> .. .. .	588
ZABRSKIE, J. L.— <i>Endosperm of Phytelphas and Smilacina</i> .. .. .	588
WENT, F. A. F. C.— <i>Aerial Roots of Epiphytes</i> .. .. .	588
JOLY, J.— <i>Bright Colour of Alpine Flowers</i> .. .. .	705
GROOM, P.— <i>Extra-floral Nectaries of Aleurites</i> .. .. .	705
HENSLow, G.— <i>Self-adaptation of Plants to their Environment</i> .. .. .	705
JUNGNER, J. R.— <i>Adaptation of Fruits to Climate</i> .. .. .	706
ÖSENBRUG— <i>Rumination of the Seeds of Areca Catechu</i> .. .. .	706
WEISSE, A.— <i>Mechanical Theory of Phyllotaxis</i> .. .. .	706
ČELAKOVSKY, L. J.— <i>Double Leaves of the Honeysuckle</i> .. .. .	706
BOLLEY, H. L.— <i>Root-tubercles of Leguminosæ</i> .. .. .	707
LECOMTE, H.— <i>Root-tubercles of Arachis</i> .. .. .	707
JAMIESON, T.— <i>Root-hairs</i> .. .. .	707

β. Physiology.

(1) Reproduction and Embryology.

WILLIS, J. C.— <i>Fertilization of Claytonia, Phacelia, and Monarda</i> .. .. .	84
ACQUA, C.— <i>Germination of the Pollen of Vinca major</i> .. .. .	84
SCHILBERSKY, C.— <i>Dimorphism of the Flowers of Convolvulus arvensis</i> .. .. .	84
WESTERMAIER, M.— <i>Embryology of Flowering Plants</i> .. .. .	224
KARSTEN, G.— <i>Embryology of Gnetum</i> .. .. .	224
BUSCALIONI, L.— <i>Embryology of Veronica hederæfolia</i> .. .. .	225
ROBERTSON, C., & OTHERS— <i>Cross-Pollination and Self-Pollination</i> .. .. .	225
CARRUTHERS, W.— <i>Cross-Fertilization of Cereals</i> .. .. .	226
TRELEASE, W.— <i>Pollination of Yucca</i> .. .. .	226
HANSGIRG, A.— <i>Red Colour of the Perianth</i> .. .. .	226
MOTTIER, D. M.— <i>Embryo-sac of Acer rubrum</i> .. .. .	367
KAYSER, G.— <i>Nucellus of the Ovule of Croton</i> .. .. .	368
GILTAY, E.— <i>Influence of the Pollen on the Fruit and Seed</i> .. .. .	368
JURÁNYI, L.— <i>Fertilization of Gymnosperms</i> .. .. .	368
RACIBORSKI, M.— <i>Chromatophily of the Nuclei of the Embryo-sac</i> .. .. .	473
MOLISCH, H.— <i>Physiology of Pollen</i> .. .. .	474
DIXON, H. H.— <i>Fertilization of Pinus</i> .. .. .	474
PAMMEL, L. H.— <i>Hybridism in Cucurbitaceæ</i> .. .. .	475
WAGNER, A.— <i>Pollination of Strelitzia</i> .. .. .	475
BUSCALIONI, L.— <i>Embryo-sac of Plantago</i> .. .. .	589
KNUTH, P., & OTHERS— <i>Cross-pollination and Self-pollination</i> .. .. .	589
GREEN, J. R.— <i>Germination of Pollen-grains</i> .. .. .	590
BENSON, M., & S. NAWASCHIN— <i>Embryology of the Amentiferæ</i> .. .. .	707
JACCARD, P.— <i>Embryology of Ephedra</i> .. .. .	708
GRAEBNER, P.— <i>Occasional Cleistogamy</i> .. .. .	709
GIBELLI, G., & OTHERS— <i>Cross- and Self-pollination</i> .. .. .	709
BEHRENS, J.— <i>Pollination of the Hop</i> .. .. .	710
WAITE, M. B.— <i>Pollination of the Pear</i> .. .. .	710

(2) Nutrition and Growth (including Germination, and Movements of Fluids).

LANDEL, G.— <i>Influence of the Solar Rays on Growth</i> .. .. .	84
GAIN, E.— <i>Influence of External Conditions on Growth</i> .. .. .	85
JACCARD, P.— <i>Influence of the Pressure of Gases on Growth</i> .. .. .	85

	PAGE
DEHÉRAIN, P. P.— <i>Unequal Resistance of Plants to Drought</i> .. .. .	85
WRIGHT, J. S.— <i>Cell-union in Herbaceous Grafting</i> .. .. .	85
LETELLIER, A.— <i>Growth of the Root</i> .. .. .	85
FRANK, B., & OTHERS— <i>Assimilation of Free Nitrogen by Plants</i> .. .. .	86
BOEHM, J.— <i>Capillarity and Ascent of Sap</i> .. .. .	87
JÖNSSON, B.— <i>Internal Bleeding of Plants</i> .. .. .	87
KLEBS, G.— <i>Influence of Light on the Propagation of Plants</i> .. .. .	227
VÖCHTING, H.— <i>Influence of Light on Flowers</i> .. .. .	227
MEEHAN, T.— <i>Rhythmic Growth</i> .. .. .	228
KNY, L.— <i>Physiological Function of Anthocyan</i> .. .. .	228
HEGLER, R.— <i>Influence of Mechanical Traction on Growth</i> .. .. .	228
RAUNKLER, C.— <i>Distribution of Seeds of the Cyperaceæ</i> .. .. .	368
PETER, A.— <i>Germination of Dormant Seeds</i> .. .. .	368
BENECKE, F.— <i>Rapidity of Growth</i> .. .. .	369
SCHWENDENER, S., & G. KRABBE— <i>Relation between Tension and Growth in Length</i>	369
SACHS, J.— <i>Periods of Growth and Causes of Development</i> .. .. .	369
DARWIN, F.— <i>Growth of the Fruit of Cucurbita</i> .. .. .	369
ZIEGENBEIN, E.— <i>Metastasis and Respiration in Germinating Tubers and Seeds</i> ..	370
NOLL, F.— <i>Transpiration of Succulent Plants</i> .. .. .	370
WIESNER, J.— <i>Influence of the Chemical Intensity of Light on the Growth of Plants</i>	475
NOLL, F.— <i>Influence of Phosphorus on the Growth of Plants</i> .. .. .	476
DANIEL, L.— <i>Morphology and Physiology of Grafting</i> .. .. .	476
ROMANES, G. J., & OTHERS— <i>Germination of Seeds</i> .. .. .	476
POTONIE, H.— <i>Pseudo-vascularity of Juncus bufonius</i> .. .. .	477
AMELUNG, E.— <i>Etiolation</i> .. .. .	477
VUILLEMIN, P., & E. LEGRAIN— <i>Symbiosis of Heterodera radicolica with Plants culti-</i>	
<i>ated in the Sahara</i> .. .. .	477
SCHNEIDER, A.— <i>Symbiosis of Algæ and Bacteria with Cycas</i> .. .. .	478
GUÉRIN, C.— <i>Life-history of the Mistletoe</i> .. .. .	478
NOBBE, E., & OTHERS— <i>Assimilation of Nitrogen by Plants</i> .. .. .	478
NOBBE, F., & L. HILTNER— <i>Fixation of Free Nitrogen by the Leguminosæ</i> .. .. .	479
JÖNSSON, B.— <i>Influence of Light on the Germination of Seeds</i> .. .. .	590
TOLMEI, G.— <i>Action of Magnetism on Germination</i> .. .. .	590
PFEFFER, W.— <i>Work and Pressure in Growing Plants</i> .. .. .	590
SACHS, J.— <i>Mechanomorphosis</i> .. .. .	591
SAUVAGEAU, C.— <i>Propagation of Potamogeton</i> .. .. .	591
HABERLANDT, G.— <i>Nutrition of Viviparous Mangrove-plants</i> .. .. .	591
ENGELMANN, TH. W.— <i>Production of Oxygen and Chlorophyll</i> .. .. .	592
KOSSOWITSCH, P.— <i>Fixation of Free Nitrogen by Algæ</i> .. .. .	592
GANONG, W. F.— <i>Absorption of Water by the Green Parts of Plants</i> .. .. .	592
SCHWENDENER, S., & E. STRASBURGER— <i>Ascent of Sap</i> .. .. .	593
STAHL, E., & R. MEISSNER— <i>Transpiration and Assimilation</i> .. .. .	710
BONNIER, G.— <i>Nutrition of Green Parasites</i> .. .. .	711
NEWCOMBE, F. C.— <i>Influence of Mechanical Resistance on the Development of Cells</i>	711
SCHLÆSING, T.— <i>Exchange of Carbon Dioxide and Oxygen</i> .. .. .	711
LECOMTE, H.— <i>Amount of Water absorbed by Roots</i> .. .. .	711

## (3) Irritability.

HANSGIRG, A.— <i>Movements of Flowers and Leaves</i> .. .. .	229
KLERCKER, J. AF.— <i>Movements of the Flowers of Veronica</i> .. .. .	229
SCHOLTZ, M.— <i>Movements of the Flower-stalk of Cobæa</i> .. .. .	229
PFEFFER, W.— <i>Irritability</i> .. .. .	370
NOLL, F.— <i>Geotropism and Epinasty</i> .. .. .	370
McDOUGAL, D. T.— <i>Intertwining of Tendrils</i> .. .. .	371
HALSTED, B. D.— <i>Heliotropism of the Mallow</i> .. .. .	371
ELFYING, F.— <i>Irritability in Plants</i> .. .. .	479
MİYOSHI, M.— <i>Chemotropic Movements</i> .. .. .	479
ROMANES, G. J.— <i>Heliotropism</i> .. .. .	480
FIGDOR, W.— <i>Heliotropic Sensitiveness</i> .. .. .	480
PEIRCE, G. J.— <i>Biology of Cuscuta</i> .. .. .	480
MACFARLANE, J. M.— <i>Irrito-contractility</i> .. .. .	593
JUEL, O.— <i>Mechanism of the Flowers of Schizanthus</i> .. .. .	712
CHAUVEAUD, G.— <i>Movements of the Stamens of Berberis</i> .. .. .	712



	PAGE
WRIGHT, S. G.— <i>Leaf-movement in Cercis</i> .. .. .	712
MEEHAN, T., & J. C. BAY— <i>Compass Plants</i> .. .. .	712

## (4) Chemical Changes (including Respiration and Fermentation).

AMM, A.— <i>Intramolecular Respiration</i> .. .. .	87
MESNARD, E.— <i>Transformations of Reserve-substances during Germination</i> .. .. .	230
SABLON, LECLERC DU— <i>Germination of Ricinus</i> .. .. .	230
LINDET, L.— <i>Production of Saccharose in the Germination of Barley</i> .. .. .	230
WEHMER, C.— <i>Function of Citric Acid in Assimilation</i> .. .. .	230
BARNES, C. R.— <i>Food of Green Plants</i> .. .. .	371
PFEFFER, W.— <i>Causes of the Disappearance of Reserve Food-materials from Seeds</i> .. .. .	371
PALLADINE, W.— <i>Respiration of Green and Etiolated Leaves</i> .. .. .	371
TSCHIRCH, A.— <i>Formations of Resins and Essential Oils</i> .. .. .	372
ACQUA, C.— <i>Formation of Starch in Pelargonium zonale</i> .. .. .	372
LOEW, O.— <i>Alkaline Reaction of Aquatic Plants</i> .. .. .	372
DUCLAUX, E.— <i>Analogies between Fermentation and Solar Combustion</i> .. .. .	481
COSTERUS, J. C.— <i>Storing up and Transport of Starch</i> .. .. .	593
PURJEWICZ, K.— <i>Formation and Decomposition of Organic Acids</i> .. .. .	594
PALLADINE, W.— <i>Intramolecular Respiration dependent upon Carbohydrates</i> .. .. .	594
IWANOWSKIJ, D.— <i>Influence of Oxygen on Alcoholic Fermentation</i> .. .. .	594
MARACCI, A.— <i>Formation and Transformation of Carbohydrates</i> .. .. .	713
SCHLEICHERT, F.— <i>Diastatic Ferment</i> .. .. .	713
AEREOBE, F.— <i>Influence of Light on Respiration</i> .. .. .	713
MAYER— <i>Respiration of Plants in the Shade</i> .. .. .	713
CHUDIAKOW, N. v.— <i>Intramolecular Respiration</i> .. .. .	713

## γ. General.

HENSLow, G.— <i>Origin of Endogens</i> .. .. .	87
MURRAY, G., & A. H. CHURCH— <i>Parasites on Algae</i> .. .. .	87
OLIVER, F. W.— <i>Effects of Fog on Plants</i> .. .. .	231
DEAN, B.— <i>Insectivorous Habit of Dionæa</i> .. .. .	231
TIEMANN, F., & P. KRUGER— <i>Perfume of the Violet</i> .. .. .	231
BONNIER, G.— <i>Vegetable Heat</i> .. .. .	372
MAYER, A. G.— <i>Radiation and Absorption of Heat by Leaves</i> .. .. .	373
GAYON, U., & E. DUBOURG— <i>Presence of Mannite in Wine (Mannitic Ferment)</i> .. .. .	373
MACMILLAN, C.— <i>Archenema, Protonema, and Metanema</i> .. .. .	481
GADEAU DE KERVILLE, H.— <i>Luminous Plants</i> .. .. .	714
BOKORNY, T.— <i>Purification of Streams by Chlorophyllous Plants</i> .. .. .	714
DUCLAUX— <i>Spontaneous Purification of River Water</i> .. .. .	714
GREEN, E. B., & A. W. BENNETT— <i>Parasitic Growths on the Root-hairs of Plants</i> .. .. .	763

## B. CRYPTOGRAMIA.

## Cryptogamia Vascularia.

GIBSON, R. J. HARVEY— <i>Siliceous Deposit in Selaginella</i> .. .. .	88
BOWER, F. O.— <i>Sporophyte of Equisetinae and Lycopodinae</i> .. .. .	88
CAMPBELL, D. H.— <i>Development of Marattia</i> .. .. .	88
BOWER, F. O.— <i>Structure of Lepidostrobus</i> .. .. .	88
ATEKINSON, G. F.— <i>Embryo of Ferns</i> .. .. .	373
"    " <i>Annulus of the Sporangium of Ferns</i> .. .. .	374
POTONÉ, H.— <i>Classification of Sigillariæ</i> .. .. .	374
ZEILLER, R.— <i>Sphenophyllum</i> .. .. .	374
PRANTL, K.— <i>Classification of Ferns</i> .. .. .	481
CAMPBELL, D. H.— <i>Development of Marattia</i> .. .. .	481
HEINSEN, E.— <i>Megaspore and Female Prothallium of Selaginella</i> .. .. .	594
GIBSON, R. J. HARVEY— <i>Stem of Selaginella</i> .. .. .	595
MATOUSCHEK, F.— <i>Bulbs of Cystopteris bulbifera</i> .. .. .	595
HOLLICK, A.— <i>Fossil Salvinias</i> .. .. .	595
POTONÉ, H.— <i>Position of Sphenophyllaceæ</i> .. .. .	595
POIRAULT, G.— <i>Vegetative Organs of Vascular Cryptogams</i> .. .. .	715

## Muscinææ.

PAGE

BESCHERELLE, E., & K. MÜLLER— <i>New Genera of Musci</i> .. .. .	231
BOWER, F. O.— <i>Structure of Buxbaumia</i> .. .. .	232
FARMER, J. B.— <i>Relations of Nucleus to Spore-formation in Liverworts</i> .. .. .	232
BRAITHWAITE'S <i>British Moss-Flora</i> .. .. .	374
GOEBEL, K.— <i>Vegetative Structure of Hepaticæ</i> .. .. .	374
RUGE, G.— <i>Vegetative Organs of Hepaticæ</i> .. .. .	375
REEVES, J.— <i>Stem and Leaves of Physotium</i> .. .. .	375
STEPHANI, F., & J. B. JACK— <i>New Genera of Hepaticæ</i> .. .. .	482
FARMER, J. B.— <i>Pallavicinia decipiens</i> .. .. .	483
LORCH, W.— <i>Anatomy of Mosses</i> .. .. .	596
MORIN, F.— <i>Venation of the Muscinææ</i> .. .. .	596
BRITTON, E. G.— <i>Physcomitrium</i> .. .. .	596
RABENHORST'S <i>Cryptogamic Flora of Germany (Musci)</i> .. .. .	596
BRIZI, U.— <i>Fossil Bryophytes</i> .. .. .	597
JÖNSSON, B.— <i>Respiration and Assimilation in Muscinææ</i> .. .. .	715
TILDEN, JOSEPHINE E.— <i>Elaters of Hepaticæ</i> .. .. .	716
MATTIROLO, O.— <i>Revivification of Grimaldia</i> .. .. .	716

## Characææ.

RICHTER, J.— <i>Action of External Influences on the Characææ</i> .. .. .	716
FILARSZKY, F.— <i>Monograph of Characææ</i> .. .. .	716
KNOWLTON, F.— <i>Fossil Chara</i> .. .. .	717

## Algæ.

WEST, W.— <i>New British Freshwater Algæ</i> .. .. .	1
AGARDH, J. G.— <i>New Genera of Algæ</i> .. .. .	89
SCHMIDLE, W.— <i>Algæ of the Black Forest and Rhine Country</i> .. .. .	89
STOCKMAYER, S.— <i>Pellicle of Algæ</i> .. .. .	89
ISTVÁNFFI, J.—“ <i>Meteorite Paper</i> ” .. .. .	89
HEYDRICH, F.— <i>Pleurostichidium, a New Genus of Floridææ</i> .. .. .	89
SETCHELL, W. A.— <i>Laminariacææ</i> .. .. .	90
LÜTKEMÜLLER, J.— <i>Chlorophores of Spirotænia obscura</i> .. .. .	90
HUBER, J.— <i>Epiphytic and Endophytic Chætophoracææ</i> .. .. .	90
JOHNSON, L. N.— <i>Zoospores of Draparnaldia</i> .. .. .	91
RICHTER, P.— <i>Chætomorpha Henningsii</i> .. .. .	91
WHITTING, F. C., & E. DE WILDEMAN— <i>Chlorocystis</i> .. .. .	92
FRANZÉ, R.— <i>Chlamydomonadineæ</i> .. .. .	92
KLEBAHN, H., & A. HANSGIRG— <i>New Genera of Algæ</i> .. .. .	233
DECKENBACH, K.— <i>Polymorphism of Trentepohlia</i> .. .. .	233
BARTON, B. W.— <i>Stichids and Tetrasporanges of Dasya</i> .. .. .	376
SCHMITZ, F., & M. GOMONT— <i>Actinococcus</i> .. .. .	376
KLEMM, P.— <i>Structure of Caulerpa</i> .. .. .	376
FRANZÉ, R. H.— <i>Low Forms of Algæ</i> .. .. .	376
HANSEN, A.— <i>Metastasis in Marine Algæ</i> .. .. .	483
AGARDH, J. G.— <i>New Genera of Algæ</i> .. .. .	483
ASKENASY, E.— <i>Australian Marine Algæ</i> .. .. .	483
DARBISHIRE, O. V.— <i>Phyllophora</i> .. .. .	484
KJELLMAN, F. R.— <i>Laminaria</i> .. .. .	484
LÜTKEMÜLLER, J.— <i>Pores of Desmidiacææ</i> .. .. .	484
KJELLMAN, F. R.— <i>Acrosiphonia</i> .. .. .	484
SCHMIDLE, W.— <i>Radiofilum, a new Genus of Chlorophyceæ</i> .. .. .	485
KLEMM, P.— <i>Rejuvenescence in the Siphonææ</i> .. .. .	485
COHN, F.— <i>Formation and Erosion of Rocks by Algæ</i> .. .. .	597
CHODAT, R., & J. HUBER— <i>Classification of the Lower Green Algæ</i> .. .. .	597
AGARDH, J. G.— <i>New Genera and Species of Algæ</i> .. .. .	598
SCHMITZ, F.— <i>Schizymenia</i> .. .. .	598
JOHNSON, T.— <i>Systematic Position of the Bangiacææ</i> .. .. .	599
BORDET, J.— <i>Irritability of Spermatozooids of Fuacææ</i> .. .. .	599
HUBER, J.— <i>Bulbils of Chætonema</i> .. .. .	599



	PAGE
CHODAT, R., & J. HUBER— <i>Development of Pediastrum</i> .. .. .	599
DE TONI'S <i>Sylloge Algarum</i> .. .. .	600
JAMES, J. F.— <i>Fucoides</i> .. .. .	600
JOHNSON, T.— <i>New Parasitic Alga</i> .. .. .	717
PALLA, E.— <i>Karyoid, a new Organ of Conjugatae</i> .. .. .	717
WILDEMAN, E. DE— <i>Trentepohlia</i> .. .. .	717
SHAW, W. B., & OTHERS— <i>Pleodorina, a new Genus of Volvocineæ</i> .. .. .	717

### Fungi.

ZUKAL, H.— <i>Saprophytic Fungus becoming Parasitic</i> .. .. .	92
"   " <i>Fungus growing in a saturated solution of salt</i> .. .. .	92
"   " <i>New Genera of Fungi</i> .. .. .	92
PRUNET, A., & OTHERS— <i>Parasitic Fungi</i> .. .. .	93
ATKINSON, G. F.— <i>Symbiotic Fungus of Ophioglossaceæ</i> .. .. .	94
BOURQUELOT & GRAZIANI— <i>Physiology of Penicillium Duclauxi</i> .. .. .	94
JANCZEWSKI, DE, & PIROTTA, R.— <i>Polymorphism of Cladosporium herbarum</i> .. .. .	94
NEUBNER, E.— <i>Calyciæ</i> .. .. .	94
CAVARA, F.— <i>New Zymogenous Saccharomyces</i> .. .. .	95
DANGEARD, P. A.— <i>Histological Structure and Development of Yeasts</i> .. .. .	95
THAXTER, R.— <i>Laboulbeniaceæ</i> .. .. .	95
SABOURAUD, R.— <i>Ringworm in Man</i> .. .. .	97
JONES, A. C.— <i>Fungus found in Phthisical Cavities and Sputa</i> .. .. .	97
MANGIN, L., & OTHERS— <i>Composition of the Cell-wall of Fungi</i> .. .. .	233
PEGLION, V.— <i>Malformations produced by Cystopus candidus and Ræstelia cancellata</i> .. .. .	234
NILSSON, A., & OTHERS— <i>Parasitic Fungi</i> .. .. .	234
NAWASCHIN, S.— <i>Fungus-parasite of Sphagnum</i> .. .. .	235
WEHMER, C.— <i>Fungi which produce Citric Acid</i> .. .. .	235
MOELLER, M.— <i>Spores of Yeast</i> .. .. .	235
MACH, E., & K. PORTELE— <i>Fermenting Grape- and Apple-must with Pure-bred Yeasts</i> .. .. .	235
JÖRGENSEN, A., & J. CH. HOLM— <i>Ejffront's Process for Purification and Preservation of Yeast</i> .. .. .	236
FISCHER, B.— <i>New Form of Propagation in Mycoderma</i> .. .. .	236
LAFAR, F.— <i>Acetic Acid-forming Blastomycete</i> .. .. .	236
MÖLLER, A.— <i>Fungus which forms several Different Lichens</i> .. .. .	237
TAVEL, F. V.— <i>Alternation of Generations in the Uredinææ</i> .. .. .	237
SAPPIN-TROUFFY— <i>Suckers of the Uredinææ</i> .. .. .	237
"   " <i>Pseudo-fecundation in the Uredinææ</i> .. .. .	238
VUILLEMIN, P.— <i>Fertilization of the Puccinææ</i> .. .. .	238
MAGNUS, P.— <i>Puccinias Parasitic on Compositæ</i> .. .. .	238
FLOWRIGHT, C. B., & OTHERS— <i>Puccinia Paridis and interstitialis</i> .. .. .	238
SCHEWIAKOFF, W.— <i>Achromatium oxaliferum</i> .. .. .	239
BOURQUELOT, E.— <i>Ferment in Fungi</i> .. .. .	377
CSAPODI, S.— <i>Fungi which Feed on Arsenic</i> .. .. .	377
WILDEMAN, E. DE— <i>Lagenidium and Chytridiaceæ</i> .. .. .	377
BOULANGER, E., & OTHERS— <i>New Genera of Fungi</i> .. .. .	378
LAPINE, N., & OTHERS— <i>Parasitic Fungi</i> .. .. .	378
WEHMER, C.— <i>Development of Penicillium luteum</i> .. .. .	379
HEIM, F.— <i>Aspergillus developing in Sulphate of Quinine</i> .. .. .	380
MASSE, G.— <i>Trichosphaeria Sacchari</i> .. .. .	380
MÜLLER, J.— <i>Wrinkle-scurf</i> .. .. .	380
CARLETON, C. A.— <i>Germination of the Uredinææ</i> .. .. .	380
WAGER, H.— <i>Nuclear Division in the Hymenomycetes</i> .. .. .	380
FISCHER, E.— <i>Phalloidææ</i> .. .. .	381
JANCZEWSKI, A. DE— <i>Position of Pompholyx</i> .. .. .	381
DANGEARD, P. A., & LÉGER— <i>Sexual Reproduction in Fungi</i> .. .. .	485
VUILLEMIN, P.— <i>Insertion of Spores and Direction of the Septa in Protobasids</i> .. .. .	486
THAXTER, R.— <i>Sapromyces (Naegelia)</i> .. .. .	486
DANGEARD, P. A., & LÉGER— <i>Nuclei of the Mucorini</i> .. .. .	486
DANGEARD, P. A.— <i>Structure of the Ustilaginææ</i> .. .. .	487
VUILLEMIN, P.— <i>Ustilago producing Woody Tumours</i> .. .. .	487

	PAGE
SADEBECK, R.— <i>Eroasceæ</i> .. .. .	487
DANGEARD, P. A.— <i>Structure of Lichens</i> .. .. .	487
PATERNÒ, E., & F. CROSA— <i>New Substance extracted from Lichens</i> .. .. .	488
CROMBIE'S <i>British Lichens</i> .. .. .	488
KANTHACK, A. A.— <i>Recent Researches on Saccharomycetes</i> .. .. .	488
DELAcroix, G., & OTHERS— <i>Parasitic Fungi</i> .. .. .	488
POIRAULT, G.— <i>Uredineæ and their Hosts</i> .. .. .	489
DIETEL, P.— <i>Ravenelia</i> .. .. .	490
BRUNS, E.— <i>Polysaccum</i> .. .. .	490
SCHNEIDER, A.— <i>Rhizobes</i> .. .. .	490
ZOPF, W.— <i>Pigments of Fungi</i> .. .. .	600
"    " <i>Erysiphea-like Fructification in the Saprolegniaceæ</i> .. .. .	600
BACHMANN, J.— <i>Sporanges of Thamnidium elegans</i> .. .. .	601
JACZEWSKI, A. DE— <i>Classification of the Pyrenomycetes</i> .. .. .	601
TRABUT, L., & OTHERS— <i>Parasitic Fungi</i> .. .. .	601
WÖRNIE, P.— <i>Injuries produced by Gymnosporangium</i> .. .. .	601
FISCHER, E.— <i>Sclerote of Rhododendron</i> .. .. .	602
EJMKMANN, C.— <i>Microbiology and Manufacture of Arrack</i> .. .. .	602
BEYERINCK, M. W.— <i>Schizosaccharomyces octosporus</i> .. .. .	602
BOCHICCHIO, N.— <i>Lactomyces inflans caseigrana</i> .. .. .	603
SCHRÖTER, J.— <i>History of Development of the Uredineæ</i> .. .. .	603
DIETEL, P.— <i>Alternation of Generations in the Uredineæ</i> .. .. .	603
"    " <i>Teleutospores of Uredineæ</i> .. .. .	603
LUDWIG, F.— <i>Fungus Flux of Trees</i> .. .. .	604
GASPARINI, G.— <i>Actinomyces</i> .. .. .	604
BIRO & OTHERS— <i>Fungi of Favus</i> .. .. .	604
FERRY, R., & R. HERZER— <i>Fossil Fungi</i> .. .. .	605
LESAGE, P.— <i>Influence of the Tension of Aqueous Vapour on the Growth of Fungi</i> .. .. .	718
ZOPF, W., & A. PRUNET— <i>New Genera of Chytridiaceæ</i> .. .. .	718
ZOPF, W.— <i>Woronina</i> .. .. .	718
"    " <i>Brefeld's Mesomycetes</i> .. .. .	719
DANGEARD, P. A.— <i>Sexual Reproduction in the Ustilaginæ</i> .. .. .	719
"    " <i>Sexual Reproduction among the Ascomycetes</i> .. .. .	719
WEHMER, C.— <i>Sclerote-forming Species of Penicillium</i> .. .. .	720
MAUL, R.— <i>Sclerote in Alder-fruit</i> .. .. .	720
HAUTEFEUILLE, P., & A. PERREY— <i>Wine-Yeasts</i> .. .. .	720
DANGEARD, P. A.— <i>Structure of Yeasts and their Development</i> .. .. .	721
KOCH, A., & H. HOSEUS— <i>Action of Yeasts on Glycogen</i> .. .. .	721
BAY, C.— <i>Spore-forming Saccharomyces</i> .. .. .	722
VUILLEMIN, P.— <i>Pedicel of the Teleutospores of Pucciniæ</i> .. .. .	722
KLEBAHN, H.— <i>Heterœcious Uredineæ</i> .. .. .	722
PEGLION, V., & OTHERS— <i>Parasitic Fungi</i> .. .. .	722
COBB, N. A., & F. A. F. C. WENT— <i>Diseases of the Sugar-cane</i> .. .. .	723
COSTANTIN, J., & L. MATRUCHOT— <i>Parasites of the Mushroom</i> .. .. .	723
LINDAU, G.— <i>Systematic Position of Ditiola</i> .. .. .	723
COSTANTIN, J., & L. MATRUCHOT— <i>Fixity of Race in Mushrooms</i> .. .. .	723
BAMBEKE, C. VAN— <i>Vascular Hyphæ in the Autobasidiomycetes</i> .. .. .	724
CAVARA, F.— <i>Parasitic Hymenogaster</i> .. .. .	724
MONIEZ, R.— <i>Selonosporium aquæductum (Musk-Fungus)</i> .. .. .	724
TERNI, C.— <i>Actinomyces Gruberi</i> sp. n. .. .. .	725

## Mycetozoa.

McBRIDE, T. H., & E. J. DURAND— <i>New Myxomycetes</i> .. .. .	490
HALSTED, B. D.— <i>Plasmodiophora Brassicæ</i> .. .. .	490

## Protophyta.

## a. Schizophyceæ.

SMITH, T. F.— <i>Ultimate Structure of Pleurosigma angulatum</i> .. .. .	141
LAUTERBORN, R.— <i>Structure and Cell-division of Diatoms</i> .. .. .	239
CASTRACANE & P. MIQUEL— <i>Spores of Diatoms</i> .. .. .	239
MIQUEL, P.— <i>Nucleus of Diatoms</i> .. .. .	240

	PAGE
BRUN, J.— <i>New Genera of Diatoms</i> .. .. .	240
SCHMIDT'S <i>Atlas der Diatomaceen-Kunde</i> .. .. .	240
HIERONYMUS, G., AND OTHERS— <i>Structure of the Cells of Phycochromaceæ</i> .. .. .	240
HANSRIG, A.— <i>Oscillatoriaceæ</i> .. .. .	241
GOMONT, M.— <i>Phormidium</i> .. .. .	241
WILDEMAN, E. DE, & OTHERS— <i>Scenedesmus</i> .. .. .	381
WILDEMAN, E. DE— <i>New Pleurococcus</i> .. .. .	382
TONI, G. B. DE— <i>Intra-frustular Reproduction of Diatoms</i> .. .. .	382
MÜLLER, O.— <i>Movements of Diatoms</i> .. .. .	382
SCHÜTT, F.— <i>Relationship between the Morphology and Biology of Diatoms and their Classification</i> .. .. .	382
PALLA, E., & H. ZUKAL— <i>Protoplasts of the Cyanophyceæ</i> .. .. .	383
COMBER, T.— <i>On the Unreliability of certain Characters generally accepted for Specific Diagnosis in the Diatomaceæ</i> .. .. .	428
DAVIS, B. M.— <i>Cryptoglena americana</i> sp. n. .. .. .	490
HÉRIBAUD, J.— <i>Influence of Light and of Altitude on the Striation of Diatoms</i> .. .. .	491
LAGERHEIM, G. V.— <i>Snow-flora of Spitzbergen</i> .. .. .	605
ZOPF, W.— <i>Development of Dictyosphaerium</i> .. .. .	605
CHODAT, R.— <i>Development of Raphidium</i> .. .. .	605
MIQUEL, P.— <i>Re-establishment of the Size of Diatoms</i> .. .. .	606
LAUTERBORN, R., & O. MÜLLER— <i>Movements of Diatoms</i> .. .. .	606
TILDEN, JOSEPHINE E.— <i>Filamentous Form of Protococcus</i> .. .. .	725
JÖNNSSON, B.— <i>Parasite of Gunnera</i> .. .. .	725
DANGEARD, P. A.— <i>Stichococcus bacillaris</i> .. .. .	725
STOLTERFOTH, H.— <i>On the genus Corethron</i> .. .. .	762
COMBER, T.— <i>Cleve's Synopsis of Naviculoid Diatoms</i> .. .. .	765
GROVE, E., & T. COMBER— <i>Diatoms from Natal</i> .. .. .	765

### B. Schizomycetes.

FREUDENREICH, E. V.— <i>Resistance of Bacteria to Pressure combined with a High Temperature</i> .. .. .	97
WINOGRADSKY, S.— <i>Assimilation of Atmospheric Nitrogen by Microbes</i> .. .. .	97
MARCHAL, E.— <i>Bacillus mycoides and Nitrification</i> .. .. .	98
MENY, J., & A. KAISIN— <i>Bactericidal Power of the Blood</i> .. .. .	98
ISSAEFF, B.— <i>Acquired Immunity to Pneumococcus</i> .. .. .	99
MALVOZ, E.— <i>Presence of B. coli commune and B. typhosus in Drinking-Water</i> .. .. .	99
LANDMANN— <i>Streptococcus longus in Drinking-Water</i> .. .. .	100
STRAZZA— <i>Capsule Bacillus of Ozæna</i> .. .. .	100
PFEIFFER, R.— <i>Pfeiffer's Influenza Bacillus</i> .. .. .	100
SANARELLI, J.— <i>Water Vibrios and the Ætiology of Cholera</i> .. .. .	101
BIBLIOGRAPHY .. .. .	102
WARD, H. MARSHALL— <i>Action of Light on Bacteria</i> .. .. .	241
HANSEN, E. C.— <i>Acetic Acid Bacteria</i> .. .. .	242
HESSE, W.— <i>Gaseous Products of Bacteria</i> .. .. .	242
BEYERINCK, M. W.— <i>Respiration-Figures of Mobile Bacteria</i> .. .. .	242
NOACK, F.— <i>Cancer of the Ash produced by Bacteria</i> .. .. .	243
MACCHIATI, L.— <i>Streptococcus Bombycis and the Silkworm Disease</i> .. .. .	243
SCHÜLLER— <i>Microbes in Chronic Rheumatism</i> .. .. .	243
HANKIN, E. H.— <i>Alexocytes</i> .. .. .	243
MÜNTZ, A., & H. CONDON— <i>Ammoniacal Fermentation of Earth</i> .. .. .	244
DUCLAUX, E.— <i>Microbes and Fatty Matter</i> .. .. .	244
VOGES, O.— <i>Chromogenic Water Bacteria</i> .. .. .	245
FISCHER & LEVY— <i>Presence of Diplococcus pneumoniae Fraenkel, and of Streptococcus pyogenes in Osteomyelitis and Periostitis</i> .. .. .	245
DENYS, J., & J. MARTIN— <i>Relations of Friedlaender's Pneumobacillus and of the Lactic Ferment with B. lactis aerogenes and B. typhosus</i> .. .. .	245
MÜLLER, K.— <i>Anthrax in Rats</i> .. .. .	246
DANYSZ, J.— <i>Destruction of Field Mice by means of Pathogenic Microbes</i> .. .. .	247
KIESSLING, F.— <i>Vibrio resembling Cholera Bacillus</i> .. .. .	247
HEIDER, A.— <i>Vibrio danubicus</i> .. .. .	247
ABEL, R.— <i>Viability Period of Diphtheria</i> .. .. .	248

	PAGE
ARLOING, S.— <i>Diagnostic Value of the Soluble Products of the Microbe of Peripneumonia bovina</i> .. .. .	218
JAKOWSKI, M.— <i>Mixed Infection from Tubercle Bacilli and Pyogenic Cocci</i> .. .. .	218
ARLOING, S., & E. CHANTRE— <i>Microbic Origin of Purulent Surgical Infection</i> .. .. .	219
TOLOMEI, G.— <i>Action of Ozone on Micro-organisms</i> .. .. .	383
COHN, F.— <i>Thermogenous Bacteria</i> .. .. .	384
HANSEN, E. C.— <i>Aceto-bacteria</i> .. .. .	384
MAUMUS— <i>Conversion of Starch into Sugar by Bacillus anthracis</i> .. .. .	384
SAKHAROFF, N.— <i>Composite Cilia of Bacillus</i> .. .. .	384
SMITH, TH.— <i>Gas and Acid Production by Bacteria</i> .. .. .	384
BLACHSTEIN— <i>Pathogenic Properties of Water Microbes</i> .. .. .	385
ILKEWICZ, W.— <i>Nuclei of Anthrax Spores</i> .. .. .	385
METSCHNIKOFF, E.— <i>Phagocytosis</i> .. .. .	385
HAMBURGER, H. J.— <i>New Bacterium of the Lymph</i> .. .. .	386
GÄRTNER, F.— <i>New Gas-forming Bacillus</i> .. .. .	387
DAHMEN, MAX— <i>Bactericidal Properties of Vasogen</i> .. .. .	387
SANFELICE, F.— <i>Influence of Physico-Chemical Agents on some Pathogenic Anaerobes of the Soil</i> .. .. .	387
GERMANO & MAUREA— <i>Differences between B. typhosus and Typhoid Bacilli</i> .. .. .	387
DÉLÉPINE, SHERIDAN— <i>Value of Bacteriological Diagnosis of Asiatic Cholera</i> .. .. .	388
TERNI, C.— <i>Characteristic Mobility of the Typhoid Bacillus</i> .. .. .	388
SAINT-SEVRIN, DU BOIS— <i>Red Cocco-bacillus of the Sardine</i> .. .. .	389
LASER, H.— <i>Laser's Bacillus of Mouse-disease</i> .. .. .	390
VINCENT, H.— <i>Parasite of the Madura Foot</i> .. .. .	390
BIBLIOGRAPHY .. .. .	391
BABES, O.— <i>The State and Modern Bacteriological Research</i> .. .. .	491
KLEIN, E.— <i>Morphology of Bacteria</i> .. .. .	491
PELLIEUX, E., & G. DELACROIX— <i>Bacillar Diseases of Plants</i> .. .. .	492
ZELINSKY, N.— <i>Microbes which evolve Hydrogen Sulphide</i> .. .. .	492
KHMELEVSKY, P. A.— <i>Influence of Light on Pyogenic Microbes</i> .. .. .	492
DENYS, J., & J. HAVET— <i>Leucocytes and Bactericidal Power</i> .. .. .	492
SCHOLL, H.— <i>Bactericidal Properties of Potash-Albumen</i> .. .. .	493
SANFELICE— <i>Anaerobic Micro-organisms</i> .. .. .	493
KUPIRANOW, J.— <i>Vibrios and the Production of Lactic Acid</i> .. .. .	494
MIQUEL, P.— <i>Duration of Incubation of Air and Water Micro-organisms on Gelatin</i> .. .. .	494
MÜHSAM, R., & C. SCHIMMELBUSCH— <i>Pigment production of Bacillus pyocyaneus in Symbiosis with other Organisms</i> .. .. .	495
TRAMBUSTI, A.— <i>Physiological Effect of Metabolic Products of B. Hydrophilus fuscus</i> .. .. .	495
KLEIN, E.— <i>Intracellular Bacterial Poisons</i> .. .. .	495
KLECKI, V. VON— <i>Micro-organisms of Rancid Butter</i> .. .. .	496
PASQUALE, A.— <i>Streptococci</i> .. .. .	497
DORNBERGER— <i>Streptococci in the Healthy and Unhealthy Mouth</i> .. .. .	498
CHATIN, P.— <i>Atmospheric Streptococci</i> .. .. .	498
CELLI, A., & S. SANTORI— <i>Transitory Variety of the Cholera Vibrio</i> .. .. .	498
IWÁNOFF, M.— <i>New Species of Choleraic Vibrio</i> .. .. .	498
WERNICKE— <i>Cholera Bacillus and Tobacco</i> .. .. .	499
METSCHNIKOFF, E.— <i>Artificial Variation of the Cholera Vibrio</i> .. .. .	499
STOECKLIN, H. DE— <i>Coli Group of Bacteria</i> .. .. .	499
SITTMANN & BARNOW— <i>Bacterium coli commune in Living Blood</i> .. .. .	500
BRUCE, D.— <i>Etiology of Malta Fever</i> .. .. .	500
LEHMANN, K. B.— <i>Bacillus levans</i> .. .. .	500
LOEWENBERG— <i>Microbe of Ozæna</i> .. .. .	501
WERIGO— <i>Anthrax in the Rabbit, and its Lessons</i> .. .. .	501
DAWSON, W. R.— <i>Manual of Bacteriology</i> .. .. .	502
FISCHER, B.— <i>Bacteriology of the Plankton Expedition</i> .. .. .	502
BIBLIOGRAPHY .. .. .	503
SCHICKHARDT, H.— <i>Effect of Sunlight on the Human Organism and on Micro-organisms</i> .. .. .	607
KOSSEL, H.— <i>Action of Nuclein Acid on Bacteria</i> .. .. .	607
PETRI, R. J., & A. MAASSEN— <i>Formation of Sulphuretted Hydrogen and Mercaptan by Aerobic Bacteria</i> .. .. .	607
LENTI, P.— <i>Influence of Alcohol, Glycerin, and Olive Oil on Disinfectants</i> .. .. .	608
WERTHEIM & SCHANTA— <i>Bacteriology in Surgery</i> .. .. .	608



	PAGE
RUSSELL, H. L.— <i>Bacterial Flora of the Atlantic Ocean</i> .. .. .	608
BEYERINCK, M. W.— <i>Filaments of Tubercles of Papilionaceæ</i> .. .. .	609
BOYCE, R., & OTHERS— <i>Action of Gravity on Bacterium Zopfii</i> .. .. .	609
ARLOING, S.— <i>Experimental Production of Bovine Peripneumonia</i> .. .. .	610
ABBOTT, A. C., & A. A. GHRISKEY— <i>Secondary Foci in Experimental Diphtheria</i> ..	610
HAYET, J.— <i>Bactericidal Power of Dog's Blood, and its Richness in Leucocytes</i> ..	610
SALVIOLI, J.— <i>Physiological Effect of the Soluble Products of Pyogenic Staphylococci</i>	610
PAWLOWSKY & MAKsutOFF— <i>Phagocytosis and Actinomycosis</i> .. .. .	611
WALDVOGEL, R.— <i>Growth of Streptococcus longus in Bouillon</i> .. .. .	611
FREMLIN, H. S.— <i>Differences between Bacterium coli commune and Bacillus typhosus</i>	611
GRUBER, M.— <i>Cholera Vibrio and Diagnosis of Cholera</i> .. .. .	612
DELPECH— <i>Pyelonephritis due to Staphylococcus pyogenes aureus</i> .. .. .	613
LUNKEWITSCH, M.— <i>Bacillus typhi murium and Caucasian Field Mice</i> .. .. .	613
GAWRONSKY, N.— <i>Microbes in Normal Urethra of Women</i> .. .. .	613
KOSSEL— <i>Pathogenic Action of Bacillus pyocyaneus on Human Beings</i> .. .. .	613
CHAPMAN, D.— <i>Urobacillus liquefaciens septicus</i> .. .. .	613
BIBLIOGRAPHY .. .. .	614
GALTIER, V.— <i>Influence of Bacterial Association</i> .. .. .	726
VICENTINI, P.— <i>Leptothrix racemosa</i> .. .. .	726
BÜSGEN, M.— <i>Polymorphism of Cladothrix</i> .. .. .	726
BATAILLON, E.— <i>Disease in Fresh Water</i> .. .. .	726
RANSOME, A., & S. DELÉPINE— <i>Influence of Natural Agents on Virulence of Tubercle</i>	
<i>Bacillus</i> .. .. .	726
CASSEDEBAT, P. A.— <i>Action of Sea Water on Microbes</i> .. .. .	727
MILLER— <i>Bacteriology of Teeth-pulp</i> .. .. .	727
PANE, N.— <i>Liquefaction of Gelatin by Streptococcus pyogenes</i> .. .. .	727
KUPRIANOW, J.— <i>Immunity to Diphtheria</i> .. .. .	727
LASER, H.— <i>Effect of Citric Acid on Diphtheria Bacillus</i> .. .. .	728
LECLEF, J.— <i>Sporicidal Action of Serum</i> .. .. .	728
DENYS, J.— <i>Bactericidal Power of the Body Juices</i> .. .. .	729
KOCH, A., & H. HOSAEUS— <i>New Frog-spawn Fungus</i> .. .. .	729
CATTERINA, G.— <i>Pathogenic Bacillus of Frogs</i> .. .. .	730
YERSIN— <i>Bacillus of Bubo Plague</i> .. .. .	730
METSCHNIKOFF, E.— <i>Cholera and Vibrios</i> .. .. .	730
CLAUSSEN, R.— <i>Variations of the Cholera Vibrio</i> .. .. .	731
SFRONCK, C. H. H.— <i>Cholera Vibrio of the Epidemic in Holland</i> .. .. .	731
SMITH, TH.— <i>Coarse and Fine Spirilla in Gut of Pig</i> .. .. .	731
VAN DER VELDE, H.— <i>Mechanism of the Virulence of Staphylococcus pyogenes aureus</i>	732
HEIM, L., & BORDONI-UFFREDUZZI— <i>Manuals of Bacteriology</i> .. .. .	732
BIBLIOGRAPHY .. .. .	733

## MICROSCOPY.

BIBLIOGRAPHY .. .. .	506
----------------------	-----

## a. Instruments, Accessories, &amp;c.

## (1) Stands. :

LEITZ & E. M. NELSON— <i>Leitz's New Microscope Stand (Fig. 1)</i> .. .. .	103
WIESNER, J.— <i>Microscope for Measurement of Growth of Plants</i> .. .. .	103
LEITZ'S <i>Mechanical Stage (Fig. 2)</i> .. .. .	105
NELSON, E. M.— <i>A Farmer's Microscope (Figs. 3 and 4)</i> .. .. .	106
" <i>Criticism of Nias on the Microscope</i> .. .. .	139
SWIFT'S <i>New Histological and Physiological Microscope (Figs. 17 and 18)</i> .. ..	250
BROWN, G. W., JUN.— <i>New Substage</i> .. .. .	252
DALLINGER, W. H.— <i>Swift's Four-footed Microscope</i> .. .. .	285
AMANN, J.— <i>Some Improvements and Additions to the Microscope Stand</i> .. .. .	392
NEWTON & Co.'s <i>Triple-rotating Electric Lantern</i> .. .. .	411
BROWN, J. W.— <i>A Home-made Microscope</i> .. .. .	414
SWIFT'S <i>Four-legged Microscope (Figs. 37 and 38)</i> .. .. .	505
RO-S & Co.'s " <i>Eclipse</i> " <i>Microscope (Figs. 39 and 40)</i> .. .. .	507
SWIFT'S <i>new Mechanical Stage (Fig. 41)</i> .. .. .	509

	PAGE
DALLINGER, W. H.— <i>Swift's Mechanical Stage</i> .. .. .	537
BECK'S (R. & J.) <i>Large "Continental" Model Microscope</i> (Fig. 55) .. .. .	615
KORISTKA'S <i>Microscopes</i> (Figs. 56-59) .. .. .	616
SWIFT, J.— <i>Practical Instructions for Making a Student's Microscope</i> (Figs. 60-66)	620
ROSS & Co.'s " <i>Eclipse</i> " <i>Microscopes</i> (Figs. 81-83) .. .. .	734
COUTANT, R. B.— <i>Support for the Microscope</i> (Figs. 84-87) .. .. .	737
WATSON'S <i>Grand Model Van Heurck Microscope</i> .. .. .	761
SWIFT'S <i>New Mechanical Stage</i> .. .. .	768
ZEISS'S <i>New Mechanical Stage</i> .. .. .	768
NELSON, E. M.— <i>Zentmayer's Portable Microscope</i> .. .. .	771

## (2) Eye-pieces and Objectives.

STEINHEIL, R.— <i>New Objective Setting</i> (Figs. 42 and 43) .. .. .	509
MICHELS, J.— <i>Spencer &amp; Smith's New 1/5 Objective</i> .. .. .	737
AMANN, J.— <i>Koristka Semi-Apochromatic 1/15 Objective</i> .. .. .	737

## (3) Illuminating and other Apparatus.

GUGLIELMO, G.— <i>New Exact and Easily Constructed Spherometer</i> (Fig. 5) .. .. .	107
NELSON, E. M.— <i>Chimney for a Microscope Lamp</i> (Fig. 6) .. .. .	108
LEITZ'S <i>Micrometer Screw Adjustment</i> (Fig. 7) .. .. .	109
SCHROEDER, HUGO— <i>Production of Exact Micrometer-Screws</i> (Figs. 19-21) .. .. .	252
NELSON, E. M.— <i>Construction of Silvered Lens Mirrors</i> (Fig. 22) .. .. .	254
LAFAR, F.— <i>Counting Apparatus specially adapted for Petri's Capsules</i> (Fig. 28) ..	393
HEARSON'S <i>Biological Incubators</i> (Figs. 44-47) .. .. .	511
REICHENBACH, H.— <i>Incubator for any Source of Heat</i> .. .. .	516
KORISTKA— <i>Camera Lucida after Nacet</i> (Fig. 67) .. .. .	623
CLAY WICK for <i>Microscope Lamps</i> .. .. .	738
MAGNIFIER for <i>Reading Small Print</i> .. .. .	739
CROYA— <i>The New Photometry</i> .. .. .	739
KRÜSS, H.— <i>Colorimeter with Lummer-Brodhun Prism Pair</i> (Figs. 88 and 89) .. .. .	740
NELSON, E. M.— <i>New Reflecting Camera Lucida</i> .. .. .	771

## (4) Photomicrography.

LEITZ'S <i>Photomicrographic Apparatus</i> (Fig. 8) .. .. .	109
MARKTANNER-TURNERETSCHER, G.— <i>On Instantaneous Photomicrography</i> (Fig. 9) ..	110
ZOTH, O.— <i>On the Cooling of Projection Preparations</i> (Fig. 10) .. .. .	112
MONPILLARD— <i>Orthochromatism applied to Photomicrography</i> .. .. .	113
KÖHLER, A.— <i>New Method of Illumination for Photomicrography</i> (Fig. 23) .. .. .	261
BORDEN, W. C.— <i>Stereoscopic Photomicrography</i> .. .. .	262
CUNNINGHAM, K. M.— <i>Remarkable Collection of Photomicrographs</i> .. .. .	262
ATKINSON, G. F.— <i>Photographing Plate Cultivations</i> .. .. .	263
NEUHAUSS, R.— <i>Photomicrography and Projection</i> .. .. .	393
ENGEL, S.— <i>Simple Photomicrographic Camera</i> .. .. .	393
HANSEMANN— <i>Stereoscopic Photomicrography</i> .. .. .	393
KARG, K.— <i>Photomicrograms for Purposes of Instruction</i> .. .. .	394
NELSON, E. M.— <i>Hints on Photomicrography</i> .. .. .	394
CURTIES, C. L.— <i>Apparatus for Obtaining Instantaneous Photomicrographs</i> (Fig. 48)	516
BAKER'S <i>Photographic Microscope</i> (Fig. 49) .. .. .	517
LEMARDELEY'S <i>Photographic Microscope</i> .. .. .	518
KORISTKA <i>Photomicrographic Cameras</i> (Figs. 68-70) .. .. .	623
NEUHAUSS, R.— <i>Comparison between Petroleum, Gas, and the Auer Incandescent Light with respect to their Usefulness for Photomicrographic Work</i> .. .. .	627
NEUHAUSS— <i>Photomicrograms of Ice and Snow Crystals</i> .. .. .	741
VOGEL— <i>The Optics of Photography</i> .. .. .	741

## (5) Microscopical Optics and Manipulation.

WEBER, L.— <i>Chromatic Aberration of Lenses</i> (Fig. 11) .. .. .	116
STREHL, K.— <i>Theoretical Limit to the Capacity of the Microscope</i> .. .. .	263
PIPFARD, H. G.— <i>Increasing the N.A. of Immersion Lenses</i> .. .. .	286
TUTTON, A. E.— <i>An Instrument for producing Monochromatic Light of any desired Wave-length, and its Use in Investigation of Optical Properties of Crystals</i> ..	394
FOCK, A.— <i>The Limits of the Visible</i> .. .. .	395



	PAGE
DALLINGER, W. H.— <i>Piffard's Method for Increasing the N.A. of Immersion Lenses</i> .. .. .	413
PIFFARD, H. G., & W. H. DALLINGER— <i>A Suggested Method of Increasing the N.A. of Old Achromatic Object-glasses</i> .. .. .	518
HOULBERT, C.— <i>Researches on the Optical Properties of Wood (Figs. 50-54)</i> .. .. .	519
NELSON, E. M.— <i>Simple Method for Measuring Refractive Indices of Mounting and Immersion Media</i> .. .. .	655, 771
RÖNTGEN, W. G.— <i>Experiments with a Right-angled Prism</i> .. .. .	742

## (6) Miscellaneous.

THE LATE <i>Dr. Kützing</i> .. .. .	118
PROF. <i>A. Milnes Marshall</i> .. .. .	118
PROF. <i>P. J. Van Beneden</i> .. .. .	118
NELSON, E. M.— <i>Measurement of Light and Colour Sensations</i> .. .. .	119
PATENTS for Inventions .. .. .	120
NELSON, E. M.— <i>Lovibond's Coloured Screens</i> .. .. .	138
GIFFORD, J. W.— <i>Inexpensive Screen for Monochromatic Light</i> .. .. .	141, 164
LIVERPOOL Microscopical Society .. .. .	264
MICROSCOPICAL Society of Calcutta .. .. .	264
THE LATE <i>Mr. C. Haughton Gill, F.R.M.S.</i> .. .. .	264
BEDOT, M.— <i>The late Prof. Fol</i> .. .. .	395
POUND, C. J.— <i>Stock Institute of Queensland</i> .. .. .	415
GILTAY'S (E.) <i>Introduction to the Study of Microscopy</i> .. .. .	522
BEHRENS' (H.) <i>Micro-Chemistry</i> .. .. .	522
A LITTLE <i>Diversion</i> .. .. .	523
COX, JACOB D.— <i>Plea for Systematic Instruction in the Technique of the Microscope at the University</i> .. .. .	627
CASTRACANE, A. F.— <i>Stereoscopic Vision applied to Diatoms</i> .. .. .	628
THE LATE <i>Mr. G. E. Blenkins, F.R.C.S.</i> .. .. .	742
„ <i>Mr. F. R. Cheshire</i> .. .. .	743
SÄUGER— <i>Removal of Rust from Instruments</i> .. .. .	743

## β. Technique.

LEE, A. BOLLES— <i>Microtomist's Vade-Mecum</i> .. .. .	120
NABIAS, B. DE, & J. SABRAZÈS— <i>Several Points of Histological and Bacteriological Technique</i> .. .. .	121
MAREK, J.— <i>Hints in Bacteriological Technique</i> .. .. .	265
BACHMANN, O.— <i>Manual of Microscopical Technique</i> .. .. .	266
PIERSOL'S <i>Histology</i> .. .. .	266
DEL RIO Y LARA, D. LUIS— <i>Manual of Technique</i> .. .. .	396
HUMPHREY, J. E.— <i>Zimmermann's Botanical Micro-technique</i> .. .. .	523
MILLER— <i>Short Notes on Bacteriological Technique</i> .. .. .	524
ACOSTA & GRANDE ROSSI— <i>Bacteriological Technique</i> .. .. .	524

## (1) Collecting Objects, including Culture Processes.

CORI, C. J.— <i>Stage-Aquarium (Fig. 12)</i> .. .. .	121
KOCH, A.— <i>Apparatus for Regulating the Temperature of Hatching-Ovens (Fig. 13)</i> .. .. .	122
OGATA, M.— <i>Cultivating Protozoa</i> .. .. .	123
BENEKE— <i>Puncture Cultivations</i> .. .. .	124
SCHWEINITZ, E. A. DE— <i>Culture Media for Biochemic Investigations</i> .. .. .	124
MÜLLER, K.— <i>Inoculation Apparatus for Rats and Mice</i> .. .. .	125
SCHEPILEWSKY, E. A.— <i>Hot-water Thermostat with Automatic Regulator (Fig. 14)</i> .. .. .	125
WICHMANN, H.— <i>Cultivating Ascospores</i> .. .. .	127
SANARELLI, J.— <i>Cultivating Vibrios</i> .. .. .	127
NOVY, F. G.— <i>Cultivation Media for Anaerobic Bacteria</i> .. .. .	127
SCHLOSSER, H.— <i>Urine-Agar for Cultivating Diphtheria Bacillus</i> .. .. .	128
VOGES, O.— <i>Growth of Cholera Bacilli on Potato</i> .. .. .	128
ABEL— <i>Isolating Bacillus of Diphtheria from Toys</i> .. .. .	128
LUNKEWICZ, M.— <i>Quadrangular Culture-Capsules</i> .. .. .	266
„ „ <i>Cold Stage</i> .. .. .	266
BEHRENDSEN'S <i>Steam Sterilizer</i> .. .. .	266

	PAGE
KIRCHNER, M.—Berkefeld Filter .. .. .	267
LASER, H.—Apparatus for Boiling and Cooling Water .. .. .	267
SCHILD—Formalin as Test for Typhoid Bacillus .. .. .	268
WURTZ & LERMOYER—Germicidal Properties of Human Mucus .. .. .	268
ROHRER, F.—Antibacterial Action of Oxrychinaseptol .. .. .	268
PARASCANDOLE, C.—Egg-albumen as a Cultivation Medium for Micro-organisms .. .. .	268
NASTIUKOW, M.—Egg-yolk Medium for Cultivating Influenza Bacillus .. .. .	269
MAASSEN, A.—Blood-Serum as Diagnostic Cultivation Medium for the Cholera Vibrio .. .. .	269
WORTMANN, J.—Inspissated Must and the Cultivation of Fungi .. .. .	270
ARENS—Plate Cultivations of Anaerobes .. .. .	270
TIMPE, H.—Method for Imparting Correct Reaction to Nutrient Gelatin .. .. .	270
SCHMIDT, A.—Sputum as Cultivation Medium for Pneumonia Cocci .. .. .	271
BIBLIOGRAPHY .. .. .	271
SCHERFFEL, A.—Improvement in J. af Klercker's Arrangement for the Cultivation of Living Organisms under the Microscope (Fig. 29) .. .. .	396
NOVY, F. G.—Apparatus for Cultivating Anaerobic Bacteria (Figs. 30-31) .. .. .	397
CRISTIANI, H.—Apparatus for Bacteriological Examination of Air (Fig. 32) .. .. .	398
KUTSCHER—Absence of Phosphorescence in Cholera Cultures .. .. .	399
WESENER—Preparation of Nutrient Medium for Bacteria from Eggs .. .. .	399
VOGES, O.—Cultivation of Cholera in Uschinsky's Medium .. .. .	400
KUPRIANON, J.—Obtaining Germ-free Blood-serum .. .. .	400
SMITH, J. LORRAIN—New Method of Preparing Culture Media .. .. .	524
MAASEN, A.—Non-albuminous Cultivation Media for Vibrios .. .. .	525
INGHILLERI—The Bujwid Reaction and Bouillon Cultivations .. .. .	525
HUBER—Cultivating Influenza Bacillus .. .. .	526
BOYCE, R., & A. E. EVANS—Growing and Examining Bacterium Zopfii .. .. .	526
ZENTHÖFER—Cultivating Cholera on Eggs .. .. .	526
ELSNER—Plate Diagnosis of Cholera .. .. .	526
DROSSBACH, G. P.—Examining Water for Anaerobic Bacteria .. .. .	527
SIRENA, S., & G. SCAGLIOSI—Experiments as to Vitality of Anthrax Spores in Earth and Water .. .. .	527
CAZENEUVE & ET. & N. RODET—Microbicidal Action of Gallanol .. .. .	527
WALLICZEK, H.—Testing Resistance of Bacterium coli commune to Drying .. .. .	528
KRUSE, W.—Method for Inoculating Gelatin Plates .. .. .	528
WALLICZEK, H.—Technique of Disinfection Experiments .. .. .	528
MIE, G.—Modification of Wolffhügel's Colony Counter .. .. .	529
KÖRBER, B.—Distribution of Bacteria Colonies in Esmarch's Roll Tubes .. .. .	529
MALLY, F. W.—Combination Hot Filter and Steam Sterilizer .. .. .	529
LACOUR-EYMARD—Chamberland Filter Système André .. .. .	529
UNNA, P. G.—Natural Pure Cultivations of Skin Fungi .. .. .	530
ORLOWSKI—Demonstrating Sulphuretted Hydrogen generated by Bacteria .. .. .	530
LUBINSKI, W.—Apparatus for Anaerobic Cultivations (Figs. 71 and 72) .. .. .	628
HEWLETT, R. T.—Bacteriological Examination of Air (Fig. 73) .. .. .	629
"   "   Cultivation of Tetanus Bacillus .. .. .	630
"   "   Cultivating Anaerobes in Agar .. .. .	630
FRIEDRICH, P.—Heating Arrangement of the Microscope for Bacteriological Purposes .. .. .	630
MILLER, C. O.—Aseptic Protozoa Cultures .. .. .	744
KOSSOWITSCH, P.—Apparatus for Pure Cultivation of Algæ (Fig. 90 and 91) .. .. .	744
WAKKER, J. H.—Cultivation Capsule for Fungi (Figs. 92 and 93) .. .. .	746
HEST, J. J. VAN—Air Filter (Figs. 94 and 95) .. .. .	747
BAY, J. C.—Infection Needle (Fig. 96) .. .. .	748
MIQUEL, P.—Setting Cultivations on Solid Media .. .. .	748
BUSSE, O.—Parasitic Cell-inclusions and their Cultivation .. .. .	748
KRÁL & OTHERS—Cultivating Gonococcus .. .. .	749
SCHUTZ, J. L.—Rapid Method for making Nutrient Agar .. .. .	750
DEYCKE—Nutrient Media containing Alkali Albuminates .. .. .	750

## (2) Preparing Objects.

BERKLEY, H. J.—Investigating Histology of Vertebrate Liver .. .. .	129
METCALF, M. M.—Embryology of Chiton .. .. .	129
DEMOOR, L.—Investigation of Reticulated Tissue .. .. .	130

	PAGE
SCHAFFER, J.— <i>Method for Histological Examination of Osseous Tissue</i> .. .. .	130
GIBBS, HENEAGE— <i>Demonstration of Psorosperms</i> .. .. .	130
HAUSER, G.— <i>Conservation of Bacterial Cultivations by means of Formalin</i> .. .. .	130
MIDDLEMASS— <i>Method of Preparing Fresh Sections of Brain</i> .. .. .	271
RATH, O. VOM— <i>Investigation of Spermatogenesis of Salamandra</i> .. .. .	271
BLANG, H.— <i>Preparation of Eggs of Trout</i> .. .. .	272
CONKLIN, E. J.— <i>Preparing Molluscan Ova</i> .. .. .	272
SABATIER, A.— <i>Study of Spermatogenesis of Crustacea</i> .. .. .	272
STILES, C. W.— <i>Preparation of Cestodes</i> .. .. .	273
SCHAUDINN, F.— <i>Investigation of Myxozoea</i> .. .. .	273
BECKER, J.— <i>Method for Obtaining Hæmin Crystals</i> .. .. .	273
FOA, P.— <i>Demonstrating the Cancer Parasite</i> .. .. .	273
WINKLER, F.— <i>Preparing Sections of Living Cultivations without previous Hardening</i> .. .. .	273
POTIKLO, S.— <i>Easy Method for Demonstrating Cholera Vibrios in Water</i> .. .. .	274
BEYERINCK, M. W.— <i>Demonstrating Protozoa and Spirilla in Drinking-water</i> .. .. .	274
BORREL, A.— <i>Technique for Studying Tubercle Bacilli in Lung</i> .. .. .	401
ILKEWITSCH, K.— <i>New Method for Detecting Tubercle Bacilli in Phthisical Sputum</i> .. .. .	402
CLAYPOLE, E. J.— <i>Investigation of Blood of Necturus and Cryptobranchus</i> .. .. .	402
ANDRÉ, E.— <i>Investigation of Ancylostoma</i> .. .. .	402
GROOM, T. T.— <i>Development of Cirripedia</i> .. .. .	403
JULIEN, A. A.— <i>Preparing and Staining Cover-glass Preparations</i> .. .. .	403
WASHBURN, F. L.— <i>Examination of Eggs of Limax maximus</i> .. .. .	531
SAMASSA, P.— <i>Examination of Tentacular Nerves of Helix pomatia</i> .. .. .	531
KRÜCKMANN, C.— <i>Making and Preserving Specimens of Bacteria for Museum Purposes</i> .. .. .	531
PINTNER, TH.— <i>Preservation of Marine Animals in Formaldehyde</i> .. .. .	532
LOEB, J.— <i>Simple Method for Producing two or more Embryos from one Egg</i> .. .. .	630
BORN, G.— <i>Newt Ova</i> .. .. .	631
HILL, C.— <i>Study of Living Fish-Embryos</i> .. .. .	631
SANDERS, A.— <i>Examination of Nervous System of Myxine glutinosa</i> .. .. .	631
BUTSCHINSKY, P.— <i>Embryology of Gebia littoralis</i> .. .. .	631
CHADWICK, H. C.— <i>Examination of Starfishes</i> .. .. .	631
MORGAN, T. H.— <i>Preserving Larvæ of Balanoglossus</i> .. .. .	632
LABBÉ, A.— <i>Study of Endoglobular Parasites</i> .. .. .	632
ROSEN, F.— <i>Botanical Microtechnique</i> .. .. .	632
HEINSEN, E.— <i>Preparing Megaspore and Female Prothallium of Selaginella</i> .. .. .	632
MITSUKURI, K.— <i>Preparation and Preservation of Embryos of Chelonia</i> .. .. .	750
MÜLLER, G. W.— <i>Preserving Ostracoda</i> .. .. .	751
HEDA, V.— <i>Study of Mitosis</i> .. .. .	751

### (3) Cutting, including Imbedding and Microtomes.

LEITZ <i>Microtome</i> (Fig. 15) .. .. .	131
BORN, G.— <i>A New Section-stretcher</i> (Fig. 16) .. .. .	132
SCHIEFFERDECKER, P.— <i>New Double-knife</i> (Fig. 33) .. .. .	403
ELSCHING, A.— <i>Imbedding Delicate Objects in Celloidin</i> .. .. .	404
"    " <i>Air- and Water-free Celloidin Solutions</i> .. .. .	404
PATTEN, W.— <i>Orienting Small Objects for Sectioning</i> .. .. .	532
<i>New Machine for Cutting Thin Sections of Rocks and Minerals</i> .. .. .	533
KORISTKA'S <i>Microtomes</i> (Figs. 74-76) .. .. .	635
PAL, J.— <i>Large Microtome for Brain-sections</i> (Figs. 77 and 78) .. .. .	636
INGHILLESI— <i>Quick Double-staining Method for Examination of Blood and Tissues</i> .. .. .	639
THOMFYEWSKI— <i>Demonstrating Nucleated Red Corpuscles</i> .. .. .	639
LETULLE— <i>Staining Tubercle Bacilli</i> .. .. .	640
BUNGE, R.— <i>Staining Flagella of Bacteria</i> .. .. .	640
BORCHARDT, M.— <i>Demonstration of Influenza Bacillus</i> .. .. .	640
RETTNER, E.— <i>Natural Injection</i> .. .. .	641
KEIBEL, F.— <i>Small Auxiliary Apparatus for Plate Modelling Method</i> (Figs. 97 and 98) .. .. .	752
HAMMER, J. A.— <i>Plate Models of Embryonic Livers</i> .. .. .	752
RABL, C.— <i>Methods for Examining Embryological Material</i> .. .. .	752

	PAGE
JELINEK, O.— <i>Use of Stabilite for Colloidin Preparations</i> .. .. .	753
SCHAFFER, J.— <i>Glass Receptacle for Series of Sections (Figs. 99-101)</i> .. .. .	754
SWIFT & R. SMITH— <i>Swift's Improved Rocking Microtome</i> .. .. .	767

## (4) Staining and Injecting.

FIocca's <i>Method for Spore-Staining</i> .. .. .	133
LIGNIER, O.— <i>Employment of Vesuvín for Fossil Plants</i> .. .. .	133
SÉGALL, B.— <i>Demonstrating Intercalary Rings of Nerve-fibres</i> .. .. .	133
RAMON Y CAJAL, S.— <i>Cox's Method for Demonstrating the Nerve-fibres of Central Nervous System</i> .. .. .	134
MARPMANN— <i>Examining Street Dust for Tubercle Bacilli</i> .. .. .	134
PARKER, G. H.— <i>Staining Nervous Tissue with Methylen-blue</i> .. .. .	274
STROEBE, H.— <i>Demonstrating Axis-cylinders</i> .. .. .	275
ZIMMERMANN, A.— <i>Staining Crystalloids of Cell-nuclei</i> .. .. .	275
MOELLER, H.— <i>Fixing and Staining the Nuclei and Spores of Yeast</i> .. .. .	276
JOHNSON, P.— <i>Staining Spores</i> .. .. .	276
LILIENTFELD, L.— <i>Selective Power of Cells in the Absorption of Pigments</i> .. .. .	276
NASTIUKOW & PEWSNER— <i>Staining Tubercle Bacilli in Sublimate Solutions of Anilin Dyes</i> .. .. .	276
UNNA, P. G.— <i>Simultaneous Double Stain for Leprosy and Tubercle Bacilli</i> .. .. .	277
RACIBORSKI, V.— <i>Staining-differences of Male and Female Cells</i> .. .. .	277
KANTOROWICZ— <i>Use of Thionin</i> .. .. .	405
PIANESE, G.— <i>Formic Acid Hæmatoxylin</i> .. .. .	405
ERMENGEM, E. VAN— <i>New Method of Staining Cilia of Bacteria</i> .. .. .	405
SCLAVO— <i>Method for Staining Flagella</i> .. .. .	405
NICOLLE, M., & V. MORAX— <i>Staining Flagella</i> .. .. .	406
ILKEWICZ, W.— <i>Staining Nuclei of Anthrax Spores</i> .. .. .	406
SAWTSCHENKO— <i>Microchemical Staining Reactions of Mucin</i> .. .. .	407
EHRMANN, S.— <i>Weigert's Fibrin Method</i> .. .. .	407
ANDRIEZEN, W. L.— <i>Modification of Golgi's Method for Study of Human Brain</i> .. .. .	533
LEMAIRE, A.— <i>Two new Staining-reagents for Meristems</i> .. .. .	533
SCHMIDT, A.— <i>Staining Reactions of Sputum</i> .. .. .	534
LIANZ— <i>New Procedure for Staining Gonococcus</i> .. .. .	534
CARAZZI, D.— <i>Bleaching Animals and Sections fixed with Osmic Mixtures</i> .. .. .	534
BERKLEY, H. J.— <i>Modification of Golgi Silver Stain</i> .. .. .	755
"    " <i>Staining Intrinsic Pulmonary Nerves of Mammalia</i> .. .. .	755
"    " <i>Nerve-Supply of Cardiac Ventricles</i> .. .. .	755
GALEOTTI, G.— <i>Staining Living Cells</i> .. .. .	755
SCALA, A.— <i>Artificial Colouring of Wine with Vegetable Substances</i> .. .. .	756
SEELMANN, H.— <i>Rapid Staining of Blood Corpuscles</i> .. .. .	756
HESSERT, W.— <i>Flagella-Staining without a Mordant</i> .. .. .	756
ERNST, P.— <i>Spore-staining after Maceration</i> .. .. .	757
VINCENT, H.— <i>Staining Micro-organisms in the Blood</i> .. .. .	757
TURNER, W. A.— <i>Demonstration on Recent Methods of Staining the Elements of the Central Nervous System</i> .. .. .	768

## (5) Mounting, including Slides, Preservative Fluids, &amp;c.

HERMANN, F.— <i>Formalin as a Hardening and Preservative Medium</i> .. .. .	135
ZETTNOW— <i>Cleaning New Cover-glasses</i> .. .. .	135
ZIMMERMANN, A.— <i>Dr. M. Kuster's Hollow Spheres for Microscopic Objects</i> .. .. .	135
WIESE, M.— <i>Preservative Fluid for Animals</i> .. .. .	277
BLUM, F.— <i>Formaldehyde for Hardening and Preserving</i> .. .. .	277
LEMAIRE, A.— <i>Microscopical Preparations of Algæ</i> .. .. .	277
TEMPÈRE, J., & P. MIQUEL— <i>Cleaning Diatoms</i> .. .. .	278
FABRE-DOMERGUE— <i>Slide-holder (Fig. 34)</i> .. .. .	407
PATTEN, W.— <i>Mounting Small Objects in Cells</i> .. .. .	534
ZETTNOW— <i>Cleaning Dirty Slides and Cover-glasses</i> .. .. .	535
TALMAGE, J. E.— <i>Method of Mounting Artemia fertilis</i> .. .. .	536
HARVEY, J. J.— <i>Method for Mounting Opaque Objects (Fig. 79)</i> .. .. .	641
FUNCK, E.— <i>Cleaning Cover-glasses</i> .. .. .	642
COHN, F.— <i>Uses of Formaldehyd</i> .. .. .	642



	PAGE
DONALDSON, H. H.— <i>Changes caused in Nervous Tissues by Hardening Reagents</i> ..	642
BOHLAND & OTHERS— <i>Collecting and Preserving Urinary Sediment (Fig. 80)</i> ..	643
OILMACHER, A. P.— <i>Production of Artefacts by certain Fixatives</i> .. .. .	757
ZENKER'S <i>Fixatives</i> .. .. .	758
BLUM, J.— <i>Formol as a Preservative Fluid</i> .. .. .	758
LUSTIG, A.— <i>Pacini's Preserving Fluid</i> .. .. .	758
FISCHER, A.— <i>Fixing Methods and the Granula</i> .. .. .	758
RATTRAY, J.— <i>Preserving Tow-net Material</i> .. .. .	759
ZIEGLER, H. E.— <i>New Compressorium (Fig. 102)</i> .. .. .	759

## (6) Miscellaneous.

RIEDER'S <i>Atlas of the Clinical Microscopy of the Blood</i> .. .. .	136
LUSTIG, A.— <i>Diagnosis of Water Bacteria</i> .. .. .	136
KITT'S <i>Bacteriology and Pathological Microscopy</i> .. .. .	137
GEDOELST'S <i>Bacteriology for Veterinary Surgeons</i> .. .. .	137
GÜNTHER'S <i>Bacteriology</i> .. .. .	137
EBERTH, C. J.— <i>Friedländer's Microscopical Technique</i> .. .. .	137
VON KAHLDEN'S <i>Microscopical Technique</i> .. .. .	137
DALAND, JUDSON— <i>New Method of Separating the White from the Red Blood-</i> <i>corpuscles by means of the Hamatokrit (Figs. 24-27)</i> .. .. .	278
SIEBEL, J. E.— <i>Bacteriological Examination of Air</i> .. .. .	280
HOFFMANN, L.— <i>Dithion, a New Antiseptic</i> .. .. .	281
DRÄER, A.— <i>Action of some Soziodol Preparations and of Tribromophenol-Bismuth</i> <i>on Cholera Bacilli</i> .. .. .	281
GOETHART, J. W. CHR.— <i>Drawing imperfectly visible Details with Camera lucida</i> ..	408
DENYS, J.— <i>Diagnosis of Cholera by the Microscope</i> .. .. .	535
WÉVRE, A. DE— <i>Microchemical Reaction of Vegetable Albumen</i> .. .. .	644
BENEKE & A. SEDGWICK— <i>Collection of Microscopic Preparations</i> .. .. .	760
LATAPIE, A.— <i>Fixing-board for Experiments on Animals</i> .. .. .	760

## PROCEEDINGS AND CONVERSAZIONE OF THE SOCIETY—

December 20, 1893 .. .. .	138
January 17, 1894 (Annual Meeting) .. .. .	148
Report of Council for 1893 .. .. .	148
Treasurer's Account for 1893 .. .. .	150
February 21, 1894 .. .. .	282
March 21, 1894 .. .. .	284
April 4, 1894 (Conversazione) .. .. .	409
April 18, 1894 .. .. .	413
May 16, 1894 .. .. .	417
June 20, 1894 .. .. .	536
October 17, 1894 .. .. .	761
November 21, 1894 .. .. .	764

INDEX OF NEW TERMS IN ZOOLOGY AND BOTANY .. .. .	773
--	-----

INDEX .. .. .	775
---------------	-----



MAY 19 1894

JOURNAL  
OF THE  
ROYAL MICROSCOPICAL SOCIETY.

FEBRUARY 1894.

TRANSACTIONS OF THE SOCIETY.

I.—*New British Freshwater Algæ.*

By WILLIAM WEST, F.L.S., assisted by G. S. WEST.

(Read 15th November, 1893.)

PLATES I. AND II.

NONE of the following algæ have hitherto been recorded for Britain, so it was thought that a list of them with descriptions and figures would be of interest to all algological as well as other students.

Mr. R. V. Tellam of Bodmin kindly collected the Cornish material, and Mr. J. Beanland of Bradford that from Slieve Donard. My son G. S. West and myself collected the remainder except where otherwise stated.

EXPLANATION OF PLATES.

(Explicatio iconum.)

a, a', a'', a''' = front view (a fronte visa). | c = side view (a latere visa).  
b, b' = vertical view (a vertice visa). | d = basal view of semicell (a basi visa)

PLATE I.

- Fig. 1.—*Cosmarium exiguum* Arch. var. *pressum* var. n. × 520.
- 2.—*Closterium intermedium* Ralfs var. *Hibernicum* var. n. × 520.
- 3. „ „ *subpronum* sp. n. a × 220; a' × 520.
- 4. „ „ *abruptum* West forma brevior. × 400.
- 5.—*Penium Clevei* Lund var. *crassum* var. n. × 520.
- 6 & 7. „ „ *inconspicuum* sp. n. × 520.
- 8.—*Spondylosium pulchellum* Arch. var. *pyramidatum* var. n. × 520.
- 9.—*Cylindrocystis diplospora* Lund. subsp. *major* West f. *constricta*. × 520.
- 10.—*Cosmarium subundulatum* Wille var. *Beanlandii* var. n. × 400.
- 11. „ „ *Lundellii* Delp. var. *ellipticum* var. n. × 400.
- 12. „ „ *Holmiense* Lund. var. *undatum* var. n. × 400.
- 13. „ „ *furcatospermum* sp. n. × 520.
- 14. „ „ *promontorium* sp. n. × 520.
- 15. „ „ *Thwaitesii* Ralfs var. *Scoticum* var. n. × 400.
- 16. „ „ *prominulum* Racib. var. *subundulatum* var. n. × 520.
- 17.—*Staurastrum amphidoxon* sp. n. × 400.
- 18.—*Cosmarium pyramidatum* Bréb. var. *angustatum* var. n. × 520.
- 19. „ „ *tetragonum* (Näg.) Arch. var. *pumilum* var. n. × 400.
- 20. „ „ *subretusiforme* sp. n. × 830.
- 21. „ „ *asperum* sp. n. × 400.
- 22.—*Staurastrum lanceolatum* Arch. var. *compressum* var. n. × 520.
- 23.—*Cosmarium Scoticum* sp. n. × 400.

## ALGÆ.

## Class CONFERVOIDÆ ISOGAMÆ.

## Order CONFERVACEÆ.

Genus *Aphanochæte* Berth.

- A. GLOBOSA (Nordst.) Wolle, Freshw. Alg. U.S., p. 119, t. cv. f. 5-6; *Herpoteiron globosum* Nordst. De Alg. et Char. Sandwic., p. 23, t. ii. f. 22-23; *Nordstedtia globosa* (Nordst.) Borzi, Alg. d'acqua dolce d. Papuasias, in Nuova Notarisia, 5 Apr. 1892, p. 50.

var. DEPRESSA var. n. Fig. 41.

Var. cum cellulis ellipsoideo-sphæroideis, depressis.

Diam. cell. 10-13.5  $\mu$ ; altit. cell. 6.8-9.5  $\mu$ .

Hab. New Forest, Hampshire.

## Class CONJUGATEÆ.

## Order DESMIDIACEÆ.

Genus *Spondylosium* Bréb.

- S. PULCHELLUM Arch. in Pritch. Infus., p. 724, t. iii. f. 10; *Sphærozozoma pulchellum* (Arch.) Rabh., Fl. Europ. Alg., iii. p. 153.

## PLATE II.

- Fig. 24.—*Oocystis Novæ Semliæ* Wille f. *major* Wille.  $\times$  520.  
 " 25. " " " var. *maxima* var. n.  $\times$  520.  
 " 26. " *elliptica* West f. *minor* West.  $\times$  520.  
 " 27. " *asymmetrica* sp. n.  $\times$  520.  
 " 28. " *gigas* Arch. f. *minor*.  $\times$  520.  
 " 29. " *solitaria* Wittr. var. *notabile* var. n.  $\times$  520.  
 " 30. " " f. *major* Wille.  $\times$  520.  
 " 31. " *nodulosa* sp. n.  $\times$  520.  
 " 32. " *crassa* Wittr.  $\times$  520.  
 " 33-35. " *panduriformis* sp. n. Figs. 33 and 35  $\times$  520; fig. 34  $\times$  120.  
 " 36. " " var. *pachyderma* var. n.  $\times$  520.  
 " 37. " *gigas* Arch. var. *incrassata* var. n.  $\times$  520.  
 " 38.—*Scenedesmus alternans* Reinsch. var. *apiculatus* var. n.  $\times$  520.  
 " 39, 40.—*Nephrocytium obesum* sp. n.  $\times$  520.  
 " 41.—*Aphanochæte globosa* (Nordst.) Wolle var. *depressa* var. n.  $\times$  520.  
 " 42.—*Cosmarium annulatum* (Näg.) De Bary, forma.  $\times$  400.  
 " 43.—*Staurastrum subpygmaeum* West f. *glabra*.  $\times$  520.  
 " 44.—*Xanthidium antilopæum* (Bréb.) Kütz. var. *læve* Schmidle f. *irregularis*.  $\times$  400.  
 " 45.—*Staurastrum dejectum* Bréb. subsp. *Tellamii* subsp. n.  $\times$  520.  
 " 46. " *pyramidatum* West var. *coilon* var. n.  $\times$  400.  
 " 47. " *lunatum* Ralfs var. *subarmatum* var. n.  $\times$  520.  
 " 48. " *asperum* Bréb. f. *monstrosa*.  $\times$  520.  
 " 49, 50. " *irregulare* sp. n.  $\times$  520.  
 " 51. " *grande* Buln. var. *parvum* var. n.  
 " 52.—*Arthrodesmus bifidus* Bréb. var. *truncatus* West f. *succisa*.  $\times$  520.  
 " 53.—*Staurastrum furcatum* (Ehrnb.) Bréb. var. *subsenarium* var. n.  $\times$  520.

var. PYRAMIDATUM var. n. Fig. 8.

Var. *semicellulis pyramidatis, lateribus subrectis, ad apices latissime truncatis; isthmo angustiore.*

Long. cell. 10–11  $\mu$ ; lat. 8·6–9·6  $\mu$ ; lat. isthm. 2–2·6  $\mu$ ; lat. apic. 5·8–5·9  $\mu$ ; crass. 4·8  $\mu$ .

*Hab.* Riccall Common, E. Yorks.

Genus *Pleurotæmium* Näg.

P. TRUNCATUM (Bréb.) Näg., Gattung. Einz. Alg., p. 104.

var. GRANULATUM var. n.

Var. *cum granulis confertis sed distinctis ordinatis, ambitu subpapilloso.*

Long. 405  $\mu$ ; lat. max. 55  $\mu$ .

*Hab.* Ben Laoigh, Scotland.

Genus *Closterium* Nitzsch.

C. ABRUPTUM West, Alg. Eng. Lake Distr. in Journ. Roy. Micr. Soc., 1892, p. 719, pl. IX. f. 1.

forma BREVIOR. Fig. 4.

Forma *cellulis brevioribus curvatoribusque.*

Long. 60–107  $\mu$ ; lat. 15–16  $\mu$ .

*Hab.* Ffestiniog, N. Wales.

C. INTERMEDIUM Ralfs, Brit. Desm., p. 171, t. xxix. f. 3.

var. HIBERNICUM var. n. Fig. 2.

Var. *cellulis subrectis apices versus subito inclinatis et attenuatis; striis 5 in 8·3  $\mu$ .*

Long. 290  $\mu$ ; lat. 19  $\mu$ .

*Hab.* Westport, Co. Mayo, Ireland.

*Cl. intermedium* Ralfs a. *typicum* Klebs (Desm. Ostpreuss., tab. ii. f. 16 non 15) is probably this variety. The two figures of *Cl. lineatum* Wolle (Desm. U.S., pl. vi. fig. 16) are also similar, but a little larger and not so truncate at the apices.

C. SUBPRONUM sp. n. Fig. 3.

*C. angustissimum, circiter diametro 100-plo longius, rectum, levissime curvatum prope apices, lineare, utrinque ab medio semicellularum longe attenuatum, apicibus obtusis sed angustissimis; membrana achroa et glabra.*

Long. 427  $\mu$ ; lat. 3·7  $\mu$ .

*Hab.* Malham Tarn, W. Yorks.

This differs from *Cl. pronum* Bréb. in being much narrower and having a colourless membrane without any striation. In relative length and breadth this species agrees with *Cl. aciculare* T. West, but is somewhat smaller, and does not begin to taper until half-way from the centre to the apices, which are not "very acute."

Genus *Penium* Bréb. ; De Bary.

P. INCONSPICUUM sp. n. Figs. 6 and 7.

P. minutissimum, 3-plo longius quam latus, cylindrico-fusiforme, ad apices subtruncatum, medio distincte sed leve et gradatim constrictum; a vertice visum circulare; membrana lævi et achroa.

Long. 15-17  $\mu$ ; lat. 4.8-5.4  $\mu$ .

Hab. Riccall Common, E. Yorks.; Elter Water, Lake District.

This is a very minute species of a characteristic shape. It occurred in abundance from the first-named locality.

P. CLEVEI Lund. (Desm. Suec., p. 86, tab. 5, fig. 11).

var. CRASSUM var. n. Fig. 5.

Var. cellulis diametro 2-plo longioribus, lateribus convexioribus, ad utrumque polum granulis minoribus, pyrenoidibus singulis, magnis.

Long. 80-98  $\mu$ ; lat. max. 42-43  $\mu$ ; lat. med. 39.5-40  $\mu$ .

Hab. Bog, at side of Angle Tarn, Lake District (1500 feet).

P. CUCURBITINUM Biss. in Journ. Roy. Micr. Soc., 1884, p. 197, tab. 5, fig. 7.

forma MINOR.

Long. 50-58  $\mu$ ; lat. 22.5-25  $\mu$ .

Hab. Craig-an-Lochan, Perthshire, Scotland.

Genus *Cylindrocystis* Menegh.

C. DIPLOSPORA Lund. (Desm. Suec., p. 83, tab. 5, fig. 7) subsp. MAJOR West (Freshw. Alg. of W. Ireland, p. 131, pl. xx. fig. 5.)

forma CONSTRICTA. Fig. 9.

Forma cellulis leve constrictis, cylindrica vel polos versus levissime dilatata.

Long. 109-112  $\mu$ ; lat. 48-54  $\mu$ ; lat. isthm. 45-50  $\mu$ .

Hab. Riccall Common, E. Yorks.

Genus *Euastrum* Ehrnb.

E. OBLONGUM (Grev.) Ralfs, Brit. Desm., p. 80, tab. xii.

var. CEPHALOPHORUM var. n.

Semicellulæ incisuris subapicalibus linearibus et incisuris inferioribus latis rotundatisque.

Long. 155  $\mu$ ; lat. 90  $\mu$ ; lat. isthm. 30  $\mu$ .

Hab. Spittal of Glen Shee, Perthshire, Scotland.

The *E. oblongum* figured by Wolle (Desm. U.S., pl. xxv. fig. 6) dently a form of this variety.

Genus *Cosmarium* Corda ; Ralfs.

## C. SUBRETUSIFORME sp. n. Fig. 20.

C. minutissimum,  $1\frac{1}{4}$ -plo longius quam latius, submodice constrictum. sinu aperto et obtuso; semicellulæ subrectangulares, angulis inferioribus late rotundatis, lateribus prope angulos superiores acutos retusis, apicibus latissime truncatis (rectis); a vertice visæ ellipticæ polis subacutis; a latere visæ subrotundatæ; membrana glabra.

Long.  $7\cdot8$ – $8\ \mu$ ; lat.  $6\cdot2$ – $6\cdot5\ \mu$ ; lat. apic.  $5\cdot5\ \mu$ ; lat. isthm.  $4\cdot5\ \mu$ ; crass.  $3\ \mu$ .

Hab. Borrowdale, Lake District.

This approaches *C. retusiforme* (Wille) Gutw. Flora gl. ok. Lwowa, 1891, p. 55, tab. ii. fig. 12 [= *C. Hammeri* Reinsch var. *retusiforme* Wille (Bidrag til kunds. om Norges Ferskv. Alg., p. 32, t. i. f. 16)] in its front view, but differs in its very much smaller size, its broader apices, and in its different lateral and vertical views.

## C. HOLMIENSE Lund., Desm. Suec., p. 49, tab. ii. fig. 20.

## var. UNDATUM var. n. Fig. 12.

Var. minor, semicellulis truncato-pyramidatis, utrobique triundulatis; latitudo apicis dimidium diametri basis; membrana delicatissime punctata.

Long.  $56\ \mu$ ; lat.  $34\ \mu$ ; lat. isthm.  $13\ \mu$ ; crass.  $27\ \mu$ .

Hab. Glen Shee, Perthshire, Scotland.

C. TETRAGONUM (Näg.) Arch. in Pritch. Infus., p. 732; *Euastrum tetragonum* Næg. Einz. Alg., p. 119, t. vii. A, f. 5.

## var. PUMILUM var. n. Fig. 19.

Var. minor, semicellulis truncato-pyramidatis, apicibus non undulatis.

Long.  $22\cdot5\ \mu$ ; lat.  $12\cdot5\ \mu$ ; lat. isthm.  $7\cdot5\ \mu$ ; crass.  $7\cdot5\ \mu$ .

Hab. Ben Laoigh, Scotland.

This is but half the size of the type and the semicells are more pyramidal with straight apices.

## C. LUNDELLII Delp., Spec. Desm. subalp., p. 109, t. 76, f. 62–64.

## var. ELLIPTICUM var. n. Fig. 11.

Var. minor, longior quam latior, cum isthmo angustiore.

Long.  $68\ \mu$ ; lat.  $53\ \mu$ ; lat. isthm.  $16\ \mu$ ; crass.  $26\ \mu$ .

Hab. Ben Laoigh, Scotland.

Compare with *C. galeritum* Nordst. (Desm. Bras., t. iii. f. 26) and *C. corruptum* Turn. (Freshw. Alg. of E. India, p. 51, t. viii. f. 2).

## C. PYRAMIDATUM Bréb. in Ralfs, Brit. Desm., p. 94, tab. xv. fig. 4.

## var. ANGUSTATUM var. n. Fig. 18.

Var. angustior, pæne duplo longior quam latior, angulis inferioribus non rotundatis sed pæne submamillatis, lateribus rectoribus.



Long. 90–92  $\mu$ ; lat. 48–50  $\mu$ ; lat. isthm. 13·5–15  $\mu$ .

*Hab.* Castletown, Co. Cork, Ireland.

C. SCOTICUM sp. n. Fig. 23.

C. magnum, circiter diametro  $1\frac{1}{2}$ -plo longius, profunde constrictum, incisura sublineari angusta extremo ampliata; semicellulæ truncato-pyramidatæ lateribus convexis, angulis inferioribus et superioribus rotundatis; a vertice visæ late ellipticæ; a latere visæ subcirculares; membrana granulata, granulis parvis subconcentrice margines versus ordinatis, medium versus dispersis; pyrenoidibus binis.

Long. 150  $\mu$ ; lat. 105  $\mu$ ; lat. isthm. 35  $\mu$ .

„ 130  $\mu$ ; „ 98  $\mu$ ; „ „ 46·5  $\mu$ ; crass. 62·5  $\mu$ .

*Hab.* Ben Laoigh, Craig-an-Lochan, and Glas Maol, Scotland.

It differs from *C. Schubelerii* Wille (Bidrag til Kunds. om Norges Ferskv. Alg., p. 34, t. ii. fig. 23) in its larger size, its more elongate cells of different form, its broader isthmus, its different sinus, its broadly elliptic vertical view, and its distinctly granulate membrane. The latter character as well as its form distinguishes it from *C. Ralfsii* Bréb. From *C. pseudopachydermum* Nordst. (Freshw. Alg. of New Zeal. and Austr., p. 53, tab. v. f. 20)—which it much resembles both in form and size as well as in vertical view—it also chiefly differs in its distinctly granulate membrane, which moreover distinguishes it from *C. pyramidatum* Bréb., this latter being comparatively longer and more angular in its front view, and also different in its lateral view as well as in its smaller size.

C. EXIGUUM Arch. in Micr. Journ., 1864, p. 178, t. 6, f. 32 and 33.

Cooke Brit. Desm., p. 92, t. 43, f. 4.

var. PRESSUM var. n. Fig. 1.

Var. duplo minor, paullo angustior, apicibus levissime retusis.

Long. 12·5–14·5  $\mu$ ; lat. 5·8–6·5  $\mu$ ; lat. isthm. 3·5–4·5  $\mu$ ; crass. 5  $\mu$ .

*Hab.* Elter Water, Lake District.

C. PROMINULUM Racib., Nonnul. Desmid. Polon., p. 23, tab. ii. fig. 7.

var. SUBUNDULATUM var. n. Fig. 16.

Var. semicellulis apicibus leve 4-undulatis, marginibus lateralibus superioribus leve biundulatis; a vertice visæ tumoribus medianis utrobique angustioribus, tumoribus prope apices majoribus et distantioribus de polis acutioribus.

Long. 16–18  $\mu$ ; lat. 17–19  $\mu$ ; lat. isthm. 8–9·5  $\mu$ ; crass. 13·5  $\mu$ .

*Hab.* Elter Water, Lake District.

## C. PROMONTORIUM sp. n. Fig. 14.

C. parvum,  $1\frac{1}{3}$ -plo longius quam latius, profunde constrictum, sinu angusto-lineari extremo ampliato; semicellulæ late subrectangulares, lateribus subirregulariter biundulatis, undula superiore subacuta, angulis inferioribus rotundatis, angulis superioribus acutis, apicibus late subconvexo-truncatis, seriebus granulorum parvorum irregularium intra ambitum totum; a vertice visæ ellipticæ, utroque latere medio elevatione parva; a latere visæ rotundo-ovatæ lateribus subretusis; pyrenoidibus singulis.

Long.  $22\ \mu$ ; lat.  $17\ \mu$ ; lat. isthm.  $3\cdot5\ \mu$ ; crass.  $10\cdot5\ \mu$ .

Hab. Oorid Lough, Connemara, W. Ireland.

This species approaches a *Euastrum* in form.

## C. SUBUNDULATUM Wille, Bidrag til Kundsk. om Norges Ferskv. Alg., p. 27, t. i. f. 9.

## var. BEANLANDII var. n. Fig. 10.

Var. diametro  $1\frac{1}{4}$ – $1\frac{1}{2}$ -plo longior, semicellulæ in margine circiter 18-undulatæ, apicibus subtruncatis subretusisque, marginem versus sine granulis distinctis; membrana punctata.

Long.  $65$ – $85\ \mu$ ; lat.  $55$ – $59\ \mu$ ; lat. isthm.  $20\cdot5$ – $22\ \mu$ ; crass.  $33\ \mu$ .

Hab. Newsholme, E. Yorks. (J. Beanland).

This is somewhat similar to *C. speciosum* Lund. var. *simplex* Nordst. (Desm. Spetsberg., p. 31, tab. vi. f. 12) but it is rather shorter and has no granules within the margin; the isthmus is also much narrower.

*C. speciosum* Lund. var. *australianum* Nordst. (Freshw. Alg. of N. Zeal. and Austr., p. 79, tab. v. fig. 9) is also somewhat similar (especially Nordstedt's fig. 9a).

C. ANNULATUM (Näg.) De Bary, Conj., p. 72; *Dysphinctium annulatum* Näg., Gattung. Einz. Alg., p. 111 tab. 6, fig. F.

Forma cellulis tribus concatenatis.

Long.  $34\cdot5$ – $36\cdot5\ \mu$ ; lat.  $14\cdot5$ – $15\ \mu$ . Fig. 42.

Hab. Ben Chiurn, Scotland.

C. BIPAPILLATUM sp. n. [= *C. Bœckii* Wille\* *bipapillatum* West, Freshw. Alg. of W. Ireland, p. 157, pl. xxi. fig. 14].

Hab. Creggan Lough, Co. Mayo, Ireland.

After further consideration this appears to be sufficiently different from *C. Bœckii* Wille to be placed as a distinct species.

## C. FURCATOSPERMUM sp. n. Fig. 13.

C. parvum, paullo longius quam latius, profunde constrictum, sinu lineari; semicellulæ truncato-semicirculares, angulis inferioribus subrectangularibus, apice truncato et subundulato, lateribus 5–6 granulatis, seriebus 1–2 granulorum

parvorum intra ambitum totius, in medio glabræ (vel levissime punctulatæ); a vertice visæ ellipticæ; a latere visæ quadrato-rotundæ.

Zygosporæ globoso-angulares, spinis tenuibus profunde bifurcatis vel trifurcatis (in ambitu 7) ornatae.

Long. 20–22  $\mu$ ; lat. 17·5–19  $\mu$ ; lat. isthm. 5·7  $\mu$ ; crass. 9–9·5  $\mu$ ; diam. zygosp. sine spin. 23–25  $\mu$ ; cum spin. 40–42  $\mu$ .

*Hab.* Orkney Is., amongst *Sphagnum* (E. Naylor).

The nearest species to this is *C. sphaerostichum* Nordst. in Nordst. et Wittr., Desm. et Ædog. in Ital. et Tyrol, p. 29, tab. xii. f. 3, from which it differs in its subundulate apices, in the centre of the semicells being glabrous (or more rarely minutely punctate), in its angular lateral view, and in its spiny zygospore.

C. ASPERUM sp. n. [= *C. scabrum* West in litt. 1891; non Turn.] Fig. 21.

C. parvum, diametro  $1\frac{1}{2}$ -plo longius, modice constrictum, sinu angusto-lineari; semicellulæ quadrato-pyramidatæ, utrobique 4 verrucis truncato-emarginatis, emarginatæ ad apicem 4 verrucis minoribus, iis ad angulos emarginatis, 2 seriebus transversis granulorum ad basim, reliquiis granulorum subregularibus; a vertice visæ oblongo-ellipticæ, ambitu profunde crenato, subinflatæ ad medium utrobique, annulo granulorum intra marginem et granulis perpaucis intra annulum, seriebus 3 transversis granulorum polos versus; a latere visæ pyramidato oblongæ, lateribus rectis scabris, 4 seriebus transversis verrucarum subquadratarum, apicibus granulatis convexis.

Long. 45  $\mu$ ; lat. 31  $\mu$ ; lat. isthm. 12·5  $\mu$ ; crass. 13·5  $\mu$ .

*Hab.* New Galloway, Kirkcudbright, Scotland (J. M'Andrew).

Compare with *C. nasutum* Nordst. (Desm. Spetsberg., p. 33, tab. 7, fig. 17).

C. THWAITESII Ralfs, Brit. Desm., p. 109, tab. xvii. fig. 8.

var. SCOTICUM var. n. Fig. 15.

Var. major, semicellulis inflatis.

Long. 95  $\mu$ ; lat. 42·5  $\mu$ ; lat. 36  $\mu$ .

„ 97  $\mu$ ; „ 43·5  $\mu$ ; „ 37·5  $\mu$ .

*Hab.* New Galloway, Kirkcudbright, Scotland (J. M'Andrew).

Genus *Xanthidium* Ehrhb.; Ralfs.

X. ANTILOPÆUM (Bréb.) Kütz. var. LÆVE Schmidle (Beiträge zur Algenfl. des Schwarzw. u. der Rhein., p. 27, t. iv. f. 7).

forma IRREGULARIS. Fig. 44.

Forma paullo major, spinis obtusis et subirregulariter dispositis; membrana glabra vel levissime punctata.

Long. sine spin. 80–82  $\mu$ ; long. cum spin. 105–115  $\mu$ ;  
lat. sine spin. 62–63  $\mu$ ; lat. cum spin. 85–100  $\mu$ ; lat. isthm.  
21–25  $\mu$ .

*Hab.* Derrycrow Bog, near Lurgan, N.E. Ireland (H. W. Lett).

This also somewhat approaches *f. evolutum* Lützk. (Desmid. aus der Umgeb. des Atters. in Oberöstr., p. 12) but differs in its much larger size and in its longer and more irregularly disposed spines.

Genus *Arthrodesmus* Ehrnb.; Arch.

A. CONVERGENS Ehrnb.

Forma membrana irregulariter punctata.

Long. 50  $\mu$ ; lat. sine spin. 50  $\mu$ ; lat. cum spin. 62  $\mu$ .

*Hab.* Corrie Ceandor, Scotland.

A. BIFIDUS Bréb. var. TRUNCATUS West (Freshw. Alg. of N. Yorks. in Journ. Bot., Oct. 1889, tab. 291, fig. 9). *f. SUCCISA*. Fig. 52.

Forma angulis superioribus truncatis vel levissime emarginatis.

Long. 12·5  $\mu$ ; lat. 11·5  $\mu$ ; lat. isthm. 3  $\mu$ ; crass. 6  $\mu$ .

*Hab.* Bowness, Lake District.

A. CONTROVERSUS sp. n. [= *A. ? glaucescens* Wittr. *f. convexa* West, Freshw. Alg. of W. Ireland, p. 170, pl. xxii. fig. 10; Freshw. Alg. of Eng. Lake District, p. 730, pl. ix. fig. 27. Non *A. ? glaucescens* Wittr., Om Gotl. och Ol. Sötvat. Alg., p. 55, t. 4, f. 11 (= *Tetrapedia glaucescens* (Wittr.) Boldt, Stud. öfv. Sötvattens-alg. och der. Utbredn., 1888, p. 59)].

*A. minutus*, paullo longior quam latior (sine spin.) modice constrictus, sinu obtusangulo et amplissimo extremo subacuminato; semicellulæ cuneatæ cum lateribus et apicibus convexis, angulis superioribus spinis brevibus delicatis ornatis; a vertice visæ circulares; membrana glabra.

Zygosporæ globosæ, aculeis simplicibus longis ornatae.

Long. 12  $\mu$ ; lat. sine spin. 10  $\mu$ ; lat. cum spin. 12·5  $\mu$ ;  
lat. isthm. 5  $\mu$ ; crass. 6·5  $\mu$ ; diam. zygosp. sine spin. 16·5  $\mu$ ,  
cum spin. 29  $\mu$ .

*Hab.* Creggan Lough, Co. Mayo, and Adrigole, Co. Cork, in Ireland. Hawkshead and Wastdale (c. zygosp.) in Lake District.

Wittrock (l.c.) described a plant as *Arthrodesmus ? glaucescens*; this has since been relegated to the genus *Tetrapedia*. I described as a form (*f. convexa*) of this plant, an *Arthrodesmus* of very similar form and dimensions; this having zygosporæ cannot be a *Tetrapedia*, but is undoubtedly a desmid and is therefore described under the above name.



Genus *Staurastrum* Meyen ; Ralfs.

S. DEJECTUM Bréb. (Ralfs, Brit. Desm., p. 121, tab. 20, fig. 5).

\* TELLAMI subsp. n. Fig. 45.

S. mediocre, paullo latius quam longius (sine acul.), profunde constrictum, sinu acutangulo; semicellulæ obverse subsemicirculares, dorso subtruncatæ et retusæ, angulis subobtusis, aculeo longo horizontali instructis; a vertice visæ triangulares, lateribus concavis, angulis subattenuatis, aculeo longo instructis.

Long. 19  $\mu$ ; lat. sine spin. 21  $\mu$ ; lat. cum spin. 48  $\mu$ ; lat. isth. 6.5  $\mu$ .

Hab. Gunwen Moor, Cornwall.

This differs from *S. dejectum* Bréb. in its longer, stouter, almost parallel spines and from *S. megacanthum* Lund. in its retuse apex, its less valid spines, its less attenuated angles, and in its much smaller size.

S. LUNATUM Ralfs. Brit. Desm., p. 124, tab. 34, fig. 12.

var. SUBARMATUM var. n. Fig. 47.

Var. angulis attenuatis in spinam mucronatam.

Long. 30  $\mu$ ; lat. c. mucr. 33  $\mu$ ; lat. isthm. 11.5  $\mu$ .

Hab. Derryclare Lough, Connemara, Ireland.

S. AVICULA Bréb. var. SUBARCUATUM (Wolle) nob. [= *St. subarcuatum*, Wolle Desm. U.S., p. 140, pl. xlv. figs. 15-16; *St. avicula* Bréb. var. *verrucosum* West, Freshw. Alg. of W. Ireland, p. 174, pl. xxiii. fig. 2; *St. denticulatum* (Näg.) Arch. as figured by Elfving, Anteck. Finska Desmid.].

Punctate and finely granulate examples of *St. avicula* occur more frequently than the glabrous forms. It is to the roughly granulate form that this variety applies. Wolle (l.c.) remarked that his species would be equally well placed as a variety of *St. avicula*; and as the Irish and American plants are identical, they are united as a variety of this species.

S. FURCATUM (Ehrnb.) Bréb.

var. SUBSENARIUM var. n. Fig. 53.

Var. cum spina simplici infra utramque spinam dorsalem bifurcatam.

Long. sine spin. 29  $\mu$ ; lat. cum spin. 39  $\mu$ ; lat. sine spin. 32.5  $\mu$ ; lat. isthm. 9.5  $\mu$ .

Hab. Leenane to Westport, Co. Mayo, Ireland.

The vertical view of this variety somewhat resembles that of *S. senarium* (Ehrnb.) Ralfs, but the lower spines of the former are simple.

S. AMPHIDOXON sp. n. Fig. 17.

S. parvum, subduplo latius quam longius, profunde constrictum; semicellulæ subellipticæ granulatae, granulis in



seriebus transversis, dorso subrecto, ventre convexo, utrobique polo in processibus brevibus tridentatis producto; a vertice visæ triangulares lateribus concavis, ad basim processuum prominentiis duabus brevibus divergentibus bifurcatis ornatae.

Long.  $22.5 \mu$ ; lat. cum proc.  $39 \mu$ ; lat. isthm.  $10 \mu$ ,  
*Hab.* New Galloway, Co. Kirkcudbright, Scotland  
(J. M'Andrew).

Compare with *S. arcuatum* Nordst.

S. ASPERUM Bréb. f. monstrosa. Fig. 48.

Long.  $36.5 \mu$ ; lat.  $34.5 \mu$ ; lat. isthm.  $13.5 \mu$ .

*Hab.* Witherslack, N. Lancashire.

S. SUBPYGMÆUM West (Freshw. Alg. of W. Ireland, p. 178, pl. xxiii. fig. 8).

f. GLABRA. Fig. 43.

Forma membrana glabra.

Long.  $42 \mu$ ; lat.  $39.5 \mu$ ; lat. isthm.  $22.5 \mu$ .

*Hab.* Borrowdale, Lake District.

The specimens were surrounded by a gelatinous matrix  $71 \mu$  in diameter.

S. LANCEOLATUM Arch.

var. COMPRESSUM var. n. Fig. 22.

Var. cum sinu angustiore et apice late truncato; a vertice visa lateribus concavioribus.

Long.  $17.3 \mu$ ; lat.  $21.1 \mu$ ; lat. isthm.  $7.5 \mu$ .

*Hab.* New Forest, Hampshire.

S. INCONSPICUUM Nordst. var. CRASSUM Gay (Essai Monogr. Conjug., p. 68, t. 3, f. 10). Forma pentagona.

Long.  $15.5 \mu$ ; lat.  $15 \mu$ ; lat. isthm.  $6.5 \mu$ .

*Hab.* Glen Caragh, Co. Kerry, Ireland.

S. PYRAMIDATUM West (Freshw. Alg. of W. Ireland, p. 179).

*S. muricatum* Bréb. var. *acutum* West. (Freshw. Alg. of N. Wales, p. 294, tab. 5, fig. 14)].

var. COILON var. n. Fig. 46.

Var. spinis numerosioribus; a vertice visa lateribus concavis et angulis subacutis.

Long. c. spin.  $80 \mu$ , sine spin.  $72.5 \mu$ ; lat. cum spin.

$65 \mu$ , sine spin.  $60 \mu$ ; lat. isthm.  $17.5 \mu$ .

*Hab.* Corrie Ceandor, Scotland.

Perhaps *St. spinosissimum* Turn. (Freshw. Alg. of E. India p. 113, t. xiii. f. 7) should be called var. *spinosissimum* (T.) of this species.

S. GRANDE Buln. in Hedwigia, 1861, p. 51, t. ix A, f. 14.

var. PARVUM var. n. [*S. brevispina* Bréb. var. *inerme* Wolle (Freshw. Alg. of U.S., pl. lxii. figs. 9-10) non Wille (Freshw. Alg. fra Nov. Seml., p. 52, t. xiii. f. 62)]. Fig. 51.

Var. minor isthmo angustiore et angulis rotundioribus.  
Long.  $62 \mu$ ; lat.  $60 \mu$ ; lat. isthm.  $13 \cdot 5 \mu$ .

Hab. Glen Shee, Perthshire, Scotland.

S. SUBAVICULA sp. n. [= *St. arcuatum* Nordst., subsp. *subavicula* West, Freshw. Alg. of Eng. Lake District, p. 732, pl. ix. f. 25].

Dr. O. Nordstedt (in litt.) has pointed out that this cannot be a variety of his *S. arcuatum*, consequently it must rank as a distinct species.

S. OPHIURA Lund. (Desm. Suec., p. 69, tab. iv. fig. 7).

var. CAMBRICUM var. n.

Var. cellulis  $1\frac{1}{3}$ -plo latioribus quam longioribus (cum processibus); semicellulæ cuneatæ, lateribus leviter concavis, apicibus cum annulo verrucarum conicarum (*non emarginatarum*) 8 ornata, radiis brevioribus, denticulatis in margine superiore convexo; a vertice visæ 8 (raro 6, 7 et 9) radiatæ.

Long. 75–80  $\mu$ ; lat. cum proc. 98–110 (usque ad 145)  $\mu$ ; lat. isthm. 16–18·5  $\mu$ .

Hab. Capel Curig, N. Wales.

This is the same as *S. Ophiura* Lund. figured by Cooke and Wills, Grevillea, 1880), also in Cooke's Brit. Desm., pl. 59, f. 1, not the description on p. 172 (which is a translation of that of Lundell, where the apical papillæ are described in front view as bifid, and in vertical view as quadrid; Cooke's figure shows that the papillæ of the British examples were entire, and not like the Swedish). The 8-rayed forms are the most common. At the base of each semicell there is a ring of 12 rather long papillæ (not figured by Cooke).

S. IRREGULARE sp. n. Figs. 49, 50.

S. parvum, paullo longius quam latius, modice constrictum, incisura mediana minuta; cellulæ semper tortæ; semicellulæ trapezicæ, apicibus glabris et subconcavis; angulis superioribus in processibus brevibus crenulato-denticulatis divergentibus productis, apice processus bidenticulato; a vertice visæ biradiatæ subirregulares, medio utrobique projectione prominenti truncata subdenticulata ad apicem; a latere visæ subirregulares, projectione ad basim utrobique.

Long. cum proc. 15·3–18·2  $\mu$ ; sine proc. 9·4–9·6  $\mu$ ; lat. cum proc. 13·5–17·3  $\mu$ ; lat. isthm. 4·8–5·7  $\mu$ ; crass. 6·6–7·7  $\mu$ .

Hab. Ballynahinch, Co. Galway, Ireland.

This seems a very characteristic species, probably coming nearest to *St. tetracerum* Ralfs.

Class PROTOCOCCOIDEÆ.

Order EREMOBIUM.

Genus *Nephrocytium* Näg.

N. LUNATUM West (Algæ of the Eng. Lake District, Journ. Roy. Micr. Soc., Dec. 1892, p. 736, tab. x. fig. 49).

Forma cellulis crassioribus.

Long. cell. 17–18  $\mu$ ; lat. cell. 6–6.5  $\mu$ ; long. tegument. 43  $\mu$ ; lat. tegument. 26  $\mu$ .

Hab. Mourne Mts., Co. Down, Ireland.

N. OBESUM sp. n. Figs. 39, 40.

N. cellulis subsemicircularibus, angulis rotundatis, ventre rectis vel levissimè concavis, diametro circiter 1½-plo longioribus; familiis e cellulis 2 formatis; tegumento hyalino, valde incrassato, diametro circiter 1¼-plo longioribus; contentum chlorophyllosum cellularum læte viride granulatum.

Long. cell. 34–42  $\mu$ ; lat. cell. 24–28  $\mu$ ; long. tegument. 82–90  $\mu$ ; lat. tegument. 57–71  $\mu$ .

Hab. Bog at the side of Angle Tarn, Lake District (1500 feet).

The stout subhemispherical cells and the very thick integument sufficiently distinguish this species.

Genus *Oocystis* Näg.

O. NOVÆ SEMLLIE Wille (Ferskv. Alg. fra Nov. Seml., p. 26, tab. xii. fig. 3).

forma MAJOR Wille (l. c., p. 27, tab. xii. fig. 4.)

F. cellulis in familiis e 16 cellulis formatis consociatis.

Long. cell. 11.1  $\mu$ , lat. 7  $\mu$ . Lat.: long. = 1:1.58

„ 11.5  $\mu$ , „ 7.5  $\mu$ . „ = 1:1.53

„ 12  $\mu$ , „ 7.7  $\mu$ . „ = 1:1.56

„ 12.5  $\mu$ , „ 7.9  $\mu$ . „ = 1:1.58

Long. fam. 40  $\mu$ ; lat. fam. 35  $\mu$ . Fig. 24.

Hab. New Forest, Hampshire.

var. MAXIMA var. nov. Fig. 25.

Var. cellulis 2–3-plo major quam forma typica. Familiis e 2–4 cellulis compositis.

Long. cell. 19  $\mu$ , lat. 12  $\mu$ . Lat.: long. = 1:1.58

„ 21.4  $\mu$ , „ 14.2  $\mu$ . „ = 1:1.52

„ 21.6  $\mu$ , „ 14  $\mu$ . „ = 1:1.54

„ 22.2  $\mu$ , „ 14.5  $\mu$ . „ = 1:1.53

„ 23  $\mu$ , „ 15  $\mu$ . „ = 1:1.53

Long. fam. 40–52  $\mu$ ; lat. fam. 23–42  $\mu$ .

Hab. New Forest, Hampshire.

This variety is above twice the size of the typical form, but the ratio of the length and breadth of the cells is too near both that of

the type and of the f. *major* for separation. The apices of the cells are also not incrassated.

O. ELLIPTICA West (Algæ of the Eng. Lake District, Journ. Roy. Micr. Soc., Dec. 1892, p. 736, pl. X. fig. 56) forma MINOR West (l. c.)

Long. cell.	18 $\mu$ ;	lat. cell.	8.2 $\mu$ .	Lat. : long.	= 1 : 2.19
"	19 $\mu$ ;	"	8.8 $\mu$ .	"	= 1 : 2.15
"	20.2 $\mu$ ;	"	9.6 $\mu$ .	"	= 1 : 2.10
"	20.8 $\mu$ ;	"	10 $\mu$ .	"	= 1 : 2.08
Long. fam.	52 $\mu$ ;	lat. fam.	35 $\mu$ .	Fig.	26.

*Hab.* Derryclare Lough, Connemara, Ireland.

The last and the preceding tables show the difference in the comparative length and breadth of the cells between *O. elliptica* f. *minor* and forms of *O. Novæ Semliæ*.

O. GIGAS Arch. in Quart. Journ. Micr. Science, 1877, p. 105 ; Cooke, Brit. Freshw. Alg., p. 26.

*O. magna* ; cellulis solitariis vel in familiis e 2 cellulis formatis consociatis ; cellulis late ellipticis,  $1\frac{1}{4}$ -plo longioribus quam latioribus, apicibus latissime rotundatis et non-incrassatis ; contentum chlorophyllosum cellularum granulosum læte viride.

Long. cell.	41 $\mu$ ;	lat. cell.	32.5 $\mu$ .	Lat. : long.	= 1 : 1.26.
"	50.5 $\mu$ ;	"	40 $\mu$ .	"	= 1 : 1.26.
Diam. fam.	1 cell. 67 $\times$ 52 $\mu$ .				

*Hab.* Lough Shannaclontippen, Connemara, and Slieve Donard, Co. Down, Ireland ; Bowness, Lake District.

f. MINOR. Fig. 28.

F. cellulis minoribus,  $1\frac{2}{5}$ -plo longioribus quam latioribus, singula vel in familiis e 4 cellulis compositis.

Long. cell.	36.2 $\mu$ ;	lat. cell.	26 $\mu$ .	Lat. : long.	= 1 : 1.39
"	38 $\mu$ ;	"	27 $\mu$ .	"	= 1 : 1.40
"	40 $\mu$ ;	"	28.5 $\mu$ .	"	= 1 : 1.40
Fam.	4 cell. 76 $\times$ 63 $\mu$ .				

*Hab.* Derryclare and Shannaclontippen Loughs, Connemara, Ireland.

var. INCRASSATA var. n. Fig. 37.

Var. membrana cellularum incrassata et apicibus incrassatis et subprotuberantibus.

Long. cell. 56  $\mu$  ; lat. cell. 39  $\mu$ .

*Hab.* Gunwen Moor, Cornwall.

This variety has the cells somewhat compressed at the sides, and the apices are thickened and project slightly.

O. ASYMMETRICA sp. n. Fig. 27.

*O. parva* ; cellulis semper solitariis, asymmetricè oblongo-ellipticis,  $2\frac{1}{4}$ -plo longioribus quam latioribus, dorso valde con-



vexis, ventre leviter convexis; apicibus incrassatis et acuminatis; contentum cellularum viride granulatum.

Long. cell. 15  $\mu$ ; lat. cell. 7  $\mu$ .  
 „ 17  $\mu$ ; „ 7.4  $\mu$ .  
 „ 18  $\mu$ ; „ 8.6  $\mu$ .

*Hab.* Chobham Common, Surrey; Bowness, Lake District; Whernside, W. Yorks.; Lough Aunierin, Connemara, Ireland.

A very frequent species, nearest to *O. apiculata* West (Notes on Scotch Freshw. Alg. in Journ. Bot., April 1893, tab. 333, figs. 7 et 8), but having a characteristic and constant form.

*O. SOLITARIA* Wittr. in Wittr. et Nordst. Alg. aq. dulc. exsic., No. 244.

f. MAJOR Wille (Ferskv. Alg. fra Nov. Seml., p. 26).

Forma cellulis subacutis ad unumquemque polum.

Long. 48  $\mu$ ; lat. 25  $\mu$ . Fig. 30.

*Hab.* Scarf Gap Pass, Lake District.

var. NOTABILE var. n. Fig. 29.

Var. cellulis lateribus subrectis et incrassatis; membrana irregulariter punctata.

Long. 29  $\mu$ ; lat. 16.5  $\mu$ .

*Hab.* Amongst *Batrachospermum vagum* Ag., Tore Mt., Co. Kerry, Ireland.

*O. NODULOSA* sp. n. Fig. 31.

*O. mediocris*; cellulis solitariis vel in familiis e 2 cellulis formatis consociatis; cellulis oblongo-ellipticis, 1½-plo longioribus quam latioribus, apicibus late rotundatis et nodulis incrassatis.

Long. cell. 25  $\mu$ ; lat. cell. 16  $\mu$ .  
 „ 25  $\mu$ ; „ 16.5  $\mu$ .  
 „ 26  $\mu$ ; „ 17  $\mu$ . Fam. 44  $\times$  41  $\mu$ .

*Hab.* Cromagloun, Co. Kerry, Ireland.

The nodular thickening at each pole along with the more broadly elliptical cells distinguishes it from *O. crassa* Wittr. (*vide* fig. 32 for comparison).

*O. CRASSA* Wittr. in Wittr. et Nordst. Alg. Exsic., No. 355.

Contentum chlorophyllosum cellularum in massis pulvinatis parietalibus 8.

Long. cell. 19  $\mu$ ; lat. cell. 13.5  $\mu$ . Lat.: long. = 1:1.42. Fig. 32.

*Hab.* Lanlivery Moor, E. Cornwall.

*O. PANDURIFORMIS* sp. n. Figs. 33-35.

*O. magna*; cellulis solitariis vel in familiis e 4-8 cellulis formatis consociatis; cellulis 2-2½-plo longioribus quam latioribus, ovatis, lateribus leviter concavis, apicibus incrassatis et subacutis.

Long cell. 50  $\mu$ ; lat. medio 23  $\mu$ ; lat. max. 25  $\mu$ . Lat.: long. = 1:2  
 „ 57  $\mu$ ; „ 23.5  $\mu$ ; „ 25  $\mu$  „ = 1:2.28  
 „ 58  $\mu$ ; „ 25.5  $\mu$ ; „ 27  $\mu$  „ = 1:2.15  
 „ 61.5  $\mu$ ; „ 23  $\mu$ ; „ 25  $\mu$  „ = 1:2.46  
 Fam. 8-cell. 170  $\times$  146  $\mu$ .

*Hab.* Gunwen Moor, Cornwall.

f. MAJOR.

Long. cell.  $77 \mu$ ; lat. medio  $29 \mu$ ; lat. max.  $32.5 \mu$ .

*Hab.* Lakes, Clifden to Roundstone, W. Ireland.

var. PACHYDERMA var. n. Fig. 36.

Var. membrana cellularum  $2.5-2.8 \mu$  crassa.

Long. cell.  $54 \mu$ ; lat. medio  $23 \mu$ ; lat. max.  $24.5 \mu$ .

*Hab.* Bowness, Lake District.

#### Genus *Kirchneriella* Schmidle.

K. OBESA nob. [= *Selenastrum obesum* West (Freshw. Alg. of Eng. Lake District in Journ. Roy. Micr. Soc., Dec. 1892, p. 734, pl. X. fig. 50-52)].

*Hab.* Bowness, Lake District.

Since this species was described under *Selenastrum*, a new genus has been founded as *Kirchneriella* by W. Schmidle (Beiträge zur Algenfl. des Schwarzwaldes und der Rheins, p. 16, tab. iii. figs. 1-3) to include a plant described as *K. lunatum*, which has the cells enveloped in a gelatinous matrix. In the specimens observed from Bowness the cells were in a practically invisible matrix which held them together at relative distances, and which also prevented other small objects from impinging on the families. This character, along with the irregularly grouped families, brings this species under *Kirchneriella*.

#### Order PROTOCOCCACEÆ (includ. PALMELLACEÆ).

##### Genus *Scenedesmus* Meyen.

S. ALTERNANS Reinsch. (Algenfl. mittl. Frank., p. 81, tab. vi. fig. iii.).

var. APICULATUS var. n. Fig. 38.

Var. cum apiculo ad finem liberum utræque cellulæ.

Long. cell. (cum apic.)  $7.5-9.5 \mu$ ; lat. cell.  $5-5.5 \mu$ .

*Hab.* New Forest, Hampshire.

#### Class PHYCOCHROMACEÆ.

##### Order RIVULARIACEÆ.

##### Genus *Dichothrix* Zanardini.

D. INTERRUPTA sp. n.

Cæspitibus penicillatis gregariis; filis circiter  $1-1\frac{1}{2}$  millim. altis, multum ramosis subdichotome,  $15-25 \mu$  crassis in ramis superioribus; ramis superioribus sæpe adpressis; vagina crassa, lævi, fuscescente in parte inferiore, uniformi, apice hyalino; trichomatibus 2-3 (interdum 4) in vagina communi inclusis, ærugineo-olivaceis, tenuibus et interruptis, in pilum apice productis; articulis diametro æqualibus vel  $1\frac{1}{2}$ -plo longioribus; heterocystis sphericis vel subhemisphericis, basilaribus.

Crass. vag. basim versus  $19-23 \mu$ ; crass. trich.  $2-2.4 \mu$ ; crass. heterocyst.  $2.4-2.7 \mu$ .

*Hab.* Slieve Donard, Co. Down, Ireland.

D. BAUERIANA (Grun.) Bornet et Flahault (Revis. des Nostoc. Hétérocyst, p. 375).

var. HIBERNICA var. n.

Var. vagina crassiore, lamellosa; trichomatibus crassioribus; articulis 3-plo brevioribus prope basim.

Crass. vag.  $23\ \mu$ ; crass. trich.  $9\cdot5$ – $11\cdot5\ \mu$ ; diam. heterocyst.  $12\cdot12\cdot5\ \mu$ .

Hab. Slieve Donard, Co. Down, Ireland. This occurred sparingly with the last.

This variety differs considerably from the type in its thicker sheath, thicker trichomes, and shorter joints. The heterocysts are subhemispherical or semi-elliptical. It may be another species; it was only seen in small quantity.

Order CHROOCOCCACEÆ.

Genus *Chroococcus* Näg.

C. MINOR (Kütz.) Näg. (Gattungen einzelliger Algen, p. 47, t. 1 A, f. 4); Rabh. Fl. Europ. Alg., ii. p. 30 [*Protococcus minor* Kütz.].

f. MAJOR.

Diam. cell. sine tegumento  $4$ – $5\ \mu$ .

Hab. Cronkley Fell, N. Yorks; Llyn-y-cwm-ffynon and Llyn Ogwen, Carnarvonshire, N. Wales.

Genus *Glæothecæ* Näg.

G. LINEARIS Näg. (Gatt. einzell. Alg., p. 58, t. 1 G, f. 2); Rabh. Fl. Europ. Alg. ii. p. 60.

Forma cum cellulis diametro  $10$ – $12$ -plo longioribus.

Diam. cell. sine teg.  $1\cdot3\ \mu$ ; long. cell.  $13\cdot5$ – $15\cdot5\ \mu$ .

Hab. Llyn Teyrn, Snowdon, N. Wales.

Genus *Aphanothece* Näg.

A. SAXICOLA Näg. (Gatt. einzell. Alg., p. 58, t. 1 G, f. 1); Rabh. Fl. Europ. Alg., ii. p. 60.

var. VIOLACEA var. n.

Var. cytoplasmate cellularum violaceo.

Diam. cell.  $1\cdot9$ – $2\cdot1\ \mu$ ; long. cell.  $3$ – $3\cdot5\ \mu$ .

Hab. New Forest, Hampshire. Small floating gelatinous patches of a dark violet colour.

var. SPHÆRICA var. n.

Var. cellulis sphericis subsphæricisve.

Diam. cell.  $1\cdot4$ – $1\cdot7\ \mu$ .

Hab. Llyn Teyrn, Snowdon, N. Wales.

This may be distinct, the cells being smaller than the other variety noticed, and almost uniform in shape; their diameter agrees with the smallest forms of the species. This is like the other forms of this genus except in the shape of the cells, and does not belong to *Aphanocapsa*, on account of the method of division of its cells.

II.—*The President's Address: The Progress and Present State of our Knowledge of the Acari.*

By A. D. MICHAEL, F.L.S.

(*Read 17th January, 1894.*)

THE typical idea of a Presidential Address is probably a review and summary of the work done by the Society to which it is addressed during the year at the close of which the Address is delivered; and, if that Society be one having scientific objects, of the progress of science in the particular branch which the Society endeavours to promote during the same period; but if it be, or ever were, the rule to adhere strictly to that type, it is certainly now-a-days more honoured in the breach than in the observance. When a science or an instrument is young discoveries and improvements come thick and fast, if there be even a small number of earnest and able workers; but when it attains what may be called its maturity they are far from being so abundant, and a larger number of equally gifted students generally produce far less striking and showy results, even though they may be provided with better means of investigation and construction. Our favourite instrument, the improvement of which must be considered the primary object of this Society, has been brought to a high state of excellence during the existence of the Society, and greatly by means of its action. Late years have seen very important steps towards its present efficiency, but, possibly from the very magnitude of those steps themselves, further advances are necessarily few in number and less important; yet it is by the slow accretion of these smaller contributions that something more or less resembling perfection, using that word in the sense of the best that it is possible to do, is ultimately attained. During the past year the improvements have been of this nature, and, however valuable they may prove to those who use the Microscope, they would not form very attractive matter for a Presidential Address; particularly as you are all probably quite as well acquainted with them as I am. There is one point, however, which has forced itself upon my notice of late, and to which it may possibly be worth calling your attention; not altogether on account of the steps that have been made in that direction, although these are not to be despised, but rather on account of the steps which have not been made, and which we may hope to make in the future. Great attention has lately been paid to the optical part of the Microscope, with eminently successful results; but when one has a fine optical arrangement one wants to utilize it in a convenient manner, and Diatomaceæ and Bacteria are not the only things which many of us wish to see. The improvements in apparatus and technique for microscopical research have fully kept pace with those in the instrument, and in nothing are they greater than in the microtome. The introduc-



tion of mechanical means of cutting thin serial sections has so facilitated many branches of biological research that the process has been almost universally adopted, and anatomists and embryologists are inclined to ask themselves how they ever got on at all without serial sections. From the inconvenience of having the series on several slides one wants to fill a slide almost from end to end, and thus, although an inch movement of a mechanical stage is sufficient in a direction transverse to the slide, yet practically at least  $2\frac{1}{2}$  inches are required in the direction of the length of the slide; although this may be roughly accomplished by merely slipping the slide along with the finger, yet this is an unsatisfactory process, as it is difficult to take the finger off without the slide altering a little, both as to position and focus, while non-mechanical stages are infinitely worse. Constructing an elaborate organ from a series of sections is a process requiring the most earnest attention, and stage difficulties in the way are a serious hindrance; moreover, just when one is following the series most attentively the stage is apt to come against the sub-stage condenser and upset the illumination entirely. What is wanted is a smooth and fine working mechanical stage, with rectangular movements of  $2\frac{1}{2}$  inches by 1 inch, which has sufficient rigidity, will act as a finder, and which will not hit against the sub-stage condenser. It is well worth an effort to attain this difficult but most desirable end.

If we turn to what may be considered the other branch of activity of this Society, namely the work done by means of the Microscope, we at once find ourselves in the ocean. The time is past when the use of that instrument was practically confined to a limited number of experts; to-day it is the great working tool in the hands of almost every student of biology; the anatomist, the embryologist, the pathologist, the botanist, the mineralogist, and many others use it alike; and to review or summarize the work done with the Microscope would be as hopeless a task as to review that done with the pen or the knife. It was doubtless these considerations that caused one of your late Presidents to observe that in the future Presidents would be more and more forced to draw the subject-matter of their Addresses from those branches of science to which they respectively had paid special attention. This has proved to be correct; probably it is not altogether a disadvantage, for although it is reported that men who are really orators speak best when they have not anything whatever to talk about, yet plain men who are not orators are usually best worth listening to when they speak upon some subject with which they are well acquainted. Therefore you will probably anticipate that I shall address you upon that group of living creatures to which I have chiefly devoted my attention, namely the Acari; and I have thought that it might perhaps be interesting to you if I shortly brought to your notice the progress that has been made in the study of these minute beings, not merely during the past year, but since Linnæus first

founded the genus *Acarus*, and to the present state of our knowledge on the subject; not going more than I can avoid into the dry details of classification, but rather illustrating it by such of the more striking examples and incidents in life-histories as I may hope that you may be able to listen to without weariness. The genus *Acarus* was, as I said, originated by Linnæus, but the word was not; it is far older. It is found in Aristotle in its Greek form, and was probably originated by him; it is derived from ἀκαρής, uncuttable. The name was not by any means a bad idea on Aristotle's part; the wonder is, not that he thought them uncuttable, but that he ever saw them at all; but naturally, in spite of his marvellous ability, such things as Cambridge rocking microtomes were not dreamt of in Aristotle's philosophy, and I now hold in my hand a set of over 120 serial sections cut from a far smaller "uncuttable" than Aristotle can ever have seen.

When one has a word the next thing one desires to know is what it means, and therefore a clear definition of what an *Acarus* is is requisite, but it is far from easy to obtain. If we omit those few puzzling forms of life which occur on the borderland of almost every group, probably no acarologist when he looks at a living creature has the least difficulty in saying whether it is an *Acarus* or not; but if he comes to give his reasons and formulate an accurately worded definition it is a very different matter. If we refer to any of the text-books of zoology we shall find one leading idea. Claus (English translation) defines the *Acarina* as "Arachnida with stout body, the abdomen unsegmented and fused with the thorax, &c.;" Lang, one of the latest, as "Abdomen fused with cephalothorax, body unsegmented." In every one the want of segmentation, and especially the fusing of the abdomen with the cephalothorax, is the important part of the description; this sounds very clear, but unfortunately, when one becomes well acquainted with the group, it dawns upon one that the unsegmented condition must be taken in a limited sense. It is undoubtedly true of the greater number of species; but it has of late years been pointed out by Kramer and others that certain *Acari*, particularly when in an immature condition, do show very decided signs of segmentation of the abdomen. It may be, and is, said with perfect truth, that the mere transverse ringing of the cuticle is not a proof of segmentation, but when each ring has its own set of muscles it becomes suspiciously like it. The other and principal distinction, the fusing of the cephalothorax and abdomen, is perfectly correct if such creatures as some of the freshwater Mites (*Hydrachnidæ*) or the Itch Mites (*Sarcoptidæ*) be the examples taken; but if, on the contrary, we look at the great families of the *Tyroglyphidæ* (*Cheese-Mites*), the *Trombididæ*, the *Oribatidæ*, the *Phytoptidæ*, and many others, the distinction between cephalothorax and abdomen appears sufficiently plain. Take such a species as *Tyroglyphus corticalis*, described by me in the *Journal* of this Society; it hardly seems possible to deny that there is a plain distinction between cephalothorax and abdomen,

and the whole arrangement of the internal organs and of the musculature seems to favour that view. If we turn to the writings of the specialists in acarology, we find that as a rule they shirk this difficult question, starting their classification from the base-point of Acarina, which group they presume to be sufficiently marked out by the general zoologist. Some, however, have not done this; but they, although they mostly do not wholly discard the fusion of cephalothorax and abdomen as a means of identifying the mites, treat it in a very uncertain manner; and when they come to define the families they usually find themselves compelled to admit the existence of a separate abdomen. Take as an example the classification of Trouessart of Paris, which is the latest and, on the whole, the best: he makes the Mites a sub-class—Acaroidea—of which he says, “Abdomen broadly joined to the thorax and generally fused with it.” He divides his sub-class into two orders, which he calls Acarina and Vermiformia. The latter he defines as “abdomen distinct from the cephalothorax”; the former, in his table, as “abdomen anchylosed to, and fused with, the cephalothorax”; but when he comes to his fuller description of this group he modifies this statement into “abdomen *generally* anchylosed to the cephalothorax and *more or less* fused with it;” and when he comes to define the Trombidieæ, which are a portion of the group, he says, “cephalothorax very distinct from the abdomen.” I might multiply instances almost to any extent. The fact seems to be that the proper definition of the Acarina (treating that word as including all the Mites) would be, “Abdomen fused with the cephalothorax, or united to it by almost the whole breadth”; but if that be adopted, what becomes of the book definitions of the difference between Acari and Phalangidæ? A new means would probably have to be found of distinguishing them. Probably one great reason of the whole thing is that if a separate abdomen be admitted, then it must also be admitted that in such forms as *Tyroglyphus corticalis* and numerous others, if not in all the Acarina, the two hind pairs of legs are abdominal; and this clashes with the ordinary book definitions of Arachnoidea as having a legless abdomen. Nature, however, will not always be bound by classifications, and however unwilling some classifiers may be to admit that a portion of the body which bears well-developed legs can possibly be the abdomen in any of the Arachnida, it may be that it will prove to be so.

Having endeavoured, then, to get more or less of an idea of what an Acarus is we will return for a moment to the single Linnæan genus of that name. Now a Linnæan genus has a great sacredness in the eyes of many excellent zoologists and its preservation becomes a point of honour; accordingly a great struggle has been made to retain the genus *Acarus*; but unfortunately its advocates have not been by any means agreed as to what creatures should be favoured with this time-honoured name. The late Francis Pascoe was a great advocate



for the retention of Linnæan genera, and in his 'Zoological Classification' he gives *Acarus* as equivalent to *Tyroglyphus*, thus taking the common Cheese-Mite as the type. Probably it has most frequently been considered so, because it is very well known; unfortunately it has an equally well-known rival in the Itch-Mite, which many other writers took as the type, besides other competitors; and thus hopeless confusion arose. The fact is that the simple circumstance, that the knowledge of this particular group of creatures had made so little progress in Linnæus' day that he was forced to include all in one genus, is not a sufficient reason for endeavouring to keep up a type genus of Acarina when we do not attempt it in the case of Insects, Crustaceans, or other similar divisions; and accordingly no trace of the genus *Acarus* will be found in the classifications of modern specialists; the genus has expanded into an order or class, and its identity as a genus has been merged, just as a supposed species which is found to include several forms is lost when its specific name is expanded into a generic one. If, however, the genus be lost it is naturally different with the Linnæan species, they are carefully preserved; but it is well to understand what a Linnæan species means in such creatures as the Acari. The botanist, if in doubt as to what was the exact plant to which the Linnæan name was given, can usually refer to that naturalist's own *Hortus siccus* in the possession of the Linnean Society, and examine the plant itself, and, unless the specimen has been injudiciously interpolated at a later period, Linnæus' well-known handwriting will be found on the mounting-paper. The students of many of the departments of zoology are more or less in the same position, but no types have been preserved of such minute creatures as Acari; indeed so entirely has their small size hindered the retention of types, until quite lately, that although Nicolet's 'Oribatidæ of the neighbourhood of Paris,' published in 1855, was written for and appeared in the 'Archives du Muséum d'Histoire Naturelle' of that city, not a single type of any of his species was preserved either in that museum or elsewhere, and when I wrote my book on the Oribatidæ, I was not able to obtain a sight of one of Nicolet's specimens. Thus for the Linnæan species we have to rely upon his descriptions, but when we refer to them it is quite impossible to identify Acari by them. I will take an example. There is an Acarid probably known to most of you called *Gamasus crassipes*, it is a Linnæan species; but the Linnæan description would apply equally well to any one of dozens of species of Gamasidæ, or to any one of hundreds of other species belonging to totally different families. Schrank's description in 1781 might possibly identify the family, but Hermann's in 1804 is the first which would give any chance of identifying the species. Thus a Linnæan species of *Acarus* really means what the first writer who gave a description or figure from which identification is possible supposed to be the Linnæan species.

Now let us look at what, under the influence of modern investiga-



tion the single Linnæan genus of a few species has expanded into. Professor Canestrini of the University of Padua, a well-known and able zoologist, and a specialist in Acarology, in his classification which was the last before Trouessart's, contends that the differences between the Acari and the other Arachnida are too great to allow both to be included in one class, and he proposes raising them to a separate class, which he divides into six orders and thirty-five families. He was not, however, the first to regard them as a separate class, Haller and Oudemans had previously suggested the same thing. The principal reasons which impressed these respective writers were that Acari in the course of their life-histories mostly undergo transformations which have not any parallel in other Arachnida; that many of them pass through what Claparède called the "Deutovum" stage, wherein the hard external chorion of the egg splits longitudinally into two boat-shaped halves, which separate, allowing the lining membrane to become the exterior casing, and thus considerable increase in the size of the maturing egg is permitted; that some of their life-histories include the curious Hypopal stage unknown in other creatures; and certain embryological reasons; besides, possibly, the difficulties above alluded to. Trouessart felt, I think rightly, that the Acari were too closely allied to other Arachnida to be excluded from the class; but yet he thought that the difference between them and the other orders of that class was greater than that of those orders from each other, and therefore he treats them as a sub-class; he makes 10 families, 24 sub-families, and 212 genera; this is what Linnæus's single genus has come to; yet Trouessart rejects numerous genera of other authors, and new genera are springing up every month, although the Acari of the greater part of the world, with the exception of the Ticks, are still almost entirely unknown.

Before referring to any points of interest confined to particular families, I will mention what seem to me to be one or two affecting the whole order (or sub-class in Trouessart's view). A picture was lately shown at one of our exhibitions entitled "Eyes and No Eyes;" now this just expresses one of my supposed interesting points. If we take an *Erythræus* or a *Bdella* we shall find it provided with at least one pair of well-developed and conspicuous eyes. Both are very active predatory creatures, and you will probably say that the possession of eyes is what would be expected. How could they possibly catch their prey without? But most Gamasidæ and many Cheyletidæ are equally active and equally predatory, but they are entirely devoid of anything which we can recognize as an organ of vision; yet they catch such agile things as Thysanuridæ in the open, without constructing any web or trap. How do they do it? That appears a mystery. A rather good and amusing example of this difficulty recently came under my notice. I have of late years paid a good deal of attention to the Gamasidæ, chiefly in respect to their habits and anatomy. I collected one or two *Holotaspis* belonging to a

large species and also some smaller Gamasids and placed them in a cell together. I used to feed them with small insects or parts of insects. When there were plenty of insects, so that each Gamasid could, so to speak, feed at a separate table, all was well; but when a single small insect was given the *Holotaspis* did not at all approve of the smaller Gamasids sharing his meal and used to drive them away, and the small ones could be seen waiting round and watching like a set of little hungry jackals until the *Holotaspis* had finished and gone away, when they rushed in and demolished the scraps. Now how did the blind *Holotaspis* know that the smaller Gamasids were there, and how did the lesser fry know when the *Holotaspis* had finished and departed? Is it smell? I can hardly think so. How could smell enable them to catch Thysanuridæ? Is it the tactile sense? We know that eyeless Infusoria swim about by hundreds in a small quantity of water and do not collide: we can conceive that each may make some current in the water which may affect the tactile sense of its neighbours, and warn them to keep out of the way; but how shall we understand this in the case of Acari standing in air? Or do they see in some way unknown to us? Or, finally, have they some sense which we do not possess or comprehend? It is said that it is impossible for a man really to comprehend a sense which he himself does not possess. I think I remember a statement in one of the books of the writer who assumed the *nom de plume* of "The Old Shikari," to the effect that an Italian guide's warning of "Non è possibile, signore" had sent him over some crazy bridge south of the Alps; and it may be that even the sixth sense impossibility will be overcome some day.

The parasitism of Acari is also curious and interesting, because it is of so many sorts. Most people think that almost all Acari are parasitic; this is an entire mistake; by far the greater number are not anything of the kind. But amongst those that are we find almost every sort of parasitism, including some sorts rare or unknown among other creatures; we have temporary parasites and permanent parasites, parasites during youth only as in the Hydrachnidæ, parasites at all ages such as *Demodex*; parasites which derive their whole nourishment from the host, and if let alone will eventually kill it, such as *Sarcoptes* and the *Cytolichus* found on the serous membranes of the common fowl; parasites that have their food provided by the host, but in a way that is beneficial to the host itself, such as the Analgesinæ which serve to keep the feathers of birds clean without injuring them. We have mutualists, commensalists; parasites such as the Hypopi, about which I shall have something more to say, which only get up to have a ride, and use their host as we use a cab or an omnibus, and no more eat the host than we eat the cab; parasites such as the *Uropoda vegetans* of de Geer, which also seek conveyance only and attach themselves by the matter passing from the anus generally to the legs of ground beetles, so that when the

beetle grubs up anything they are in a favourable position for taking advantage of it; and endless other varieties. But perhaps one of the oddest sorts of parasitism was pointed out by Mégnin of Vincennes. If you examine the skin of a freshly killed old rabbit, you will probably find plenty of a strange and comical-looking truly parasitic Acarid, the male of which strikes one at first rather as if it had put on a microscopic Ethiopian serenader's long-tailed coat; this gentleman is *Listrophorus gibus*. Many Acari which live on mammals have singular apparatus for holding on to their hairs. The *Myobia* of the mouse and bat has a short stumpy front leg, quite different from its other legs, terminated by a great curved and flattened claw which curls round a hair and presses it against a chitinous peg on the tarsus, so that it is held between the two as in a vice. The Hypopi of the *Dermacarus sciurinus* of Haller, a parasite of the squirrel, and of the somewhat similar parasite of the mole, have a longitudinal groove on their ventral surface in which a hair lies, and movable chitinous plates which close above the hair and press it down into the groove. But *Listrophorus* is the oddest of all, for it has the under-lip expanded on each side into a flexible chitinous plate which curls round the hair and holds on very tightly, so that the rabbit could not detach it. But in spite of this the *Listrophorus* does not remain in peace. You will probably also find among the hairs another Acarus, *Cheyletus parasitivorax*, which, like all other members of the genus, is a most ferocious creature. Mégnin wanted to study the *Listrophorus* and put twelve in a glass cell, but he accidentally also put in two of the *Cheyletus*, which is about the same size as the *Listrophorus*; to his astonishment the two killed and sucked the twelve before his eyes in a very short space of time. Thus the *Cheyletus* lives permanently upon the rabbit, not to eat him or do him any harm, but to use his fur as a hunting-ground wherein to chase creatures that really do injure the host.

Now let me treat of a few matters affecting particular families only. I will not tire you by going through all, nor by attempting any systematic treatment, but will confine myself to the development of a few points in some of the leading families. One of the lowest of these great groups is the Sarcoptidæ, which by common consent is divided into at least two sections,—the Sarcoptinæ or Itch-Mites, and the Analgesinæ or Bird's Feather Parasites. The former are minute creatures degraded by parasitism, and by no means rich in number of species; but if you want to attract public attention, probably the best way is to make yourself eminently disagreeable to everybody. Béranger once wrote that "Love was not like fear for paying," and accordingly more attention and literature has probably been devoted to the Itch-Mite than to the whole of the rest of the Acarina put together. In Fürstenberg's magnificent work on these creatures, published in 1861, no less than 172 folio pages are devoted to a summary of the previous literature, as against 50 pages of original matter. 297 books and papers on the subject are enumerated in his



list, and they have been rapidly increasing in number ever since his time. This book of Fürstenberg's contains a good example of how even industrious and careful men may be led away by their fancies. In every one of the really splendid illustrations the mites are clearly depicted as possessed of two pairs of chelate mandibles, a thing not really found in any one of them or in any other known Acarid. The different Itch-Mites have been described not only from man and all his ordinary domestic quadrupeds, but also from the dromedary, llama, wombat, fox, wolf, capybara, lion, hyæna, &c. Scraping hyænas may not at first sight appear to be a pleasant occupation, but probably the investigations were conducted on dead specimens.

Closely allied to the Itch-Mites are the harmless Bird-Parasites, the Analgesinæ, familiar to all of you from the preparations of the late Mr. Cocken. It is a sub-family containing an immense number of species, which have been enormously added to by the researches of Dr. Trouessart among the bird-skins in the Paris and other museums. These creatures, particularly the males, often have very eccentric forms, but there is not amongst them perhaps anything stranger than *Freyana heteropus*, a parasite of the cormorant, which was originally made known in a paper read to this Society in 1881. Probably the male of this species and that of the equally curious *Freyana caput-medusæ*, subsequently discovered by Trouessart on the gannet, are the only instances in the whole family of any departure from strict bilateral symmetry; but in this Acarid the second leg on one side is very greatly enlarged, being much longer than its fellow on the opposite side; not only is this so, but the enlarged leg is supported by a much stronger and quite differently arranged sternal skeleton from that of the other half of the body. Three years after my paper, Trouessart, who had accidentally missed it, published a description of the same species, supposing it to be new; some time afterwards it was remarked that whereas in my drawing the left leg was the enlarged one, in Trouessart's it was the right; and then arose the question which was in error; it turned out that neither was; my specimens had the left leg enlarged and the left side of the body with the strongly arranged skeleton; Trouessart's had the right leg enlarged and the right side with the interlocked skeleton, and it now appears that not only are these two forms about equally common, but also it sometimes happens that one leg of the first pair, or more rarely, the first and second leg on one side is enlarged, and the sternal skeleton varies accordingly. The office of the enlarged leg is to hold the female.

The great group of the Tyroglyphidæ or Cheese-Mites is by many authors included in the Sarcoptidæ; I cannot myself agree in this, they seem to be too different for such an arrangement; but they are undoubtedly allied families. Although it has such a homely type as the common Cheese-Mite, this family includes many of the most beautiful forms in the whole of the Acarina. But perhaps the most striking point in connection with it is that it is here that the curious



Hypopal stage before referred to occurs. A short history of the investigations into the nature of this stage is not a bad illustration of the gradual progress of knowledge of the Acarina. In 1735 de Geer noticed on the house-fly a tiny red mite with an oval body, having a polished chitinous carapace, and having instead of an ordinary mouth a minute tube apparently closed at the end but furnished with two setæ. The two front pairs of legs were well developed, but the fourth pair ended in setæ instead of claws or suckers, in this resembling the Itch-Mites. It was taken as a species, and Linnæus called it *Acarus muscarum*. Other writers added new allied species, until it came to Dugès, who in 1834 created the genus *Hypopus* for them. Other writers continued to add species, and Koch in 1848 divided the genus, forming a new one, *Homopus*, to receive some of the creatures. Gervais next added a new species, which oddly enough he associated with *Tyroglyphus*, although apparently without any idea of the connection which has lately been ascertained to exist between them. Up to 1847 no one doubted that these were adult creatures forming a separate group of Acari, but at this time Dujardin made a great advance; he expressed his opinion that they were all immature forms; he called attention to the numerous ventral suckers by which they attached themselves to other creatures, and to the absence, as he considered, of any mouth-organs and of any reproductive organs. He observed that certain Hypopi immediately before ecdysis contained within their skin, and completely filling it, an Acarus very different from themselves and possessed of chelate mandibles and palpi; he found them associated with Gamasids larger than themselves; Gamasids had chelate mandibles and palpi; the deduction was obvious, and Dujardin announced that *Hypopus* was an immature form of *Gamasus*. In 1861 Fürstenberg found a number of *Hypopi* on the skin of a stuffed elephant; he reverted to the old idea of their being special adult creatures; with his accustomed minuteness he described their maxillæ and the number of joints in their palpi; he carried his measurements to the 1/10,000 of a millimetre. The only unfortunate part is that as these creatures do not possess maxillæ or palpi there has been a little difficulty in understanding what Fürstenberg meant. Next Gerlach tried the subject; he had been studying the Itch-Mites; the hind legs of Hypopus resembled those of Itch-Mites, and had not Fürstenberg found them on the elephant? It was not at all surprising that Gerlach should proclaim them to be Itch-Mites. In 1868 Claparède brought his genius and industry to bear upon the subject. He had been studying the life-history of *Hoplophora*, one of the Oribatidæ, which is soft and white when immature, but hard and brown when adult. Claparède found a new species of *Tyroglyphus*, he kept it in confinement, breeding large numbers over a period of three years, but he never could detect a male; he did not find any Gamasids amongst them, but he did find numbers of Hypopi, and he actually saw nymphs of the *Tyroglyphus*, which greatly resemble the adult, cast the skin and

produce a Hypopus instead of an ordinary *Tyroglyphus*; but Hypopus never contained any eggs. Again the deduction seemed clear, and Claparède announced that Hypopus was the male of *Tyroglyphus*. But Robin and Fumose had found the *Tyroglyphus* as well as Claparède. Of course neither knew of the other's study, but the French paper appeared just before the Swiss, and Robin and Fumose had found the male, which is very like the female. In 1873 Mégnin took up the study and came very near the truth indeed; he experimented on *Tyroglyphus mycophagus* and another species, both found in great numbers on mushrooms; he bred his creatures in cases, supplying them with pieces of fresh mushrooms from time to time; he found that when the mushrooms and cages got dry the *Tyroglyphi* disappeared, but were replaced by swarms of Hypopi; when fresh moist mushroom was added the Hypopi were again replaced by *Tyroglyphi*. Mégnin concluded that when from the dryness of the atmosphere or other unfavourable circumstances the nymphs of *Tyroglyphus* were unable to live, they had the power of turning into *Hypopi*, which could support drought, &c., and of thus passing the period until the conditions had again become favourable. In 1876 our countryman Andrew Murray contributed a suggestion. Dujardin had seen the creature with chelate mandibles inside the Hypopus, Claparède and Mégnin had seen the Hypopus inside the other. Murray suggested that what Dujardin supposed to be inside was really underneath and seen through, and that Hypopus was a ferocious creature which attacked other mites from below, ate its way in, and then devoured its host, leaving only the skin. The absence of mouth-organs in Hypopus did not seem to trouble Murray. Between 1882 and 1884, I myself conducted a series of experiments with a view to settling the question; it would take far too long to detail these experiments, but I found that Hypopus was undoubtedly a stage in the life-history of *Tyroglyphus*, and that every small fly and beetle which emerged from a hot-bed, where the conditions were particularly favourable to *Tyroglyphus* life, and where that creature swarmed, was laden with Hypopi, and that in my cells the more favourable the conditions were the more Hypopi I got; but that, undoubtedly, when desiccation commenced the *Tyroglyphi* died off rapidly, while the Hypopi continued to live for a considerable time. I came to the conclusion that the Hypopal condition is a stage in the life-history of the nymph of *Tyroglyphus*, occupying the period between two ecdyses, generally the second and third, that it was not confined to either sex and did not occur in the life-history of every individual, but only of a moderate proportion, and that it was a provision of nature for ensuring the distribution of the species by enabling its members to cling to passing insects such as flies, bees, &c., and to support the exposure to sun and drought, which they would have to suffer before arriving at fresh favourable localities, and which would assuredly kill *Tyroglyphidæ* in any other stage. This view is now, I think, generally accepted; and it is satisfactory to find that it has

quite lately been confirm'd by Moniez, who has been studying *Tyroglyphus mycophagus*, Ménézin's species, and has come to conclusions absolutely identical with my own. There is a genus of Tyroglyphidæ, called *Glyciphagus*, closely allied to *Tyroglyphus*, and it seemed strange that there should not be an Hypopus-stage here also; but although Ménézin, and I, and others hunted among the millions of *Glyciphagi* which are found in favourable situations, we could not find the Hypopus. About 1885 it struck me that amongst the immense numbers of cast and dried-up skins of *Glyciphagus spinipes* and *G. domesticus* which one finds in old barns, &c., certain of them looked different from the others, having a more opaque cuticle and more apparent contents. I transferred these to my breeding-cells and found that they were not dead at all, but that nearly adult nymphs emerged from them. I also observed that the case, as I called it, from which the nymph of *G. spinipes* emerged did not appear wholly empty; I cut some open and found that each contained a cast skin resembling that of a Hypopus. I then dissected some of the cases at an earlier stage, and there I found a Hypopus in a somewhat imperfect state, alive and just able to crawl a little, but white and soft and unfit for exterior life. It seems, as far as I could trace it, that this Hypopus never emerged, but passed the whole stage inside the case, only the more adult nymph, which is formed within the Hypopus, emerging after the ecdysis. Thus the Hypopal stage appears to be dying out here, and in *G. domesticus* it seems to have become even more vestigial, for all that can be found is a protoplasmic mass, the shape of a Hypopus it is true, but without legs or movement. Ménézin, who found something still more rudimentary, where all shape of a Hypopus is lost, thought that these cases might be blown about by the wind and the species thus distributed.

From the Tyroglyphidæ to the Gamasidæ is a great jump, for, in spite of the absence of eyes before mentioned, the latter is one of the most highly organized of Acarine families; but time is short, and I have been a good deal interested in them of late. Some years ago Sir John Lubbock sent me a very curious Gamasid, which he had found in one of his ants' nests, that of *Lasius flavus*. Haller had previously found an equally strange but quite different Gamasid in the nests of *Formica nigra*. I had long wished to pursue this subject a little further, and in the spring of 1891, when I was staying in Corsica, and in the Tyrol near Innsbruck, I made a systematic hunt of ants' nests, with the result that I found no less than nine species of Gamasids, all except one new to science, living in the ants' nests searched on friendly terms with the ants. Each species of Gamasid associated with one or two species of ant only; so that, after a little experience, I got to know what species of Gamasid I was likely to find when I saw what the sort of ant was. The ants seemed to take some care of the Gamasids, and would sometimes carry them off to a place of safety when the nest was disturbed. It was extremely difficult to find out what office the Gamasids per-



formed, but as far as I could ascertain, some of them ate the dead ants and helped to keep the place clean. It appears, however, that I was not the only person searching ants' nests with the same object. About that time Wasmann, whose studies of the social Hymenoptera are well known, but who was not an acarologist, had, it appears, been for some time collecting Acari and Insects from ants' nests, and amongst other places had actually collected at Innsbruck. He had sent his collection to Prof. Moniez to work out, and Moniez was doing so when my papers appeared. Wasmann had naturally found many of my species, but he had also found two or three others, and it was interesting to see that he had found the creatures under similar circumstances to my own. Prof. Berlese had also been hunting ants' nests, and here a still more curious circumstance occurred. One of my Corsican species which I had observed in the nest had a knack when disturbed of jumping up actively on to the broad flat head of the nearest ant, and sitting there calmly while the ant carried it away, looking exactly as if it were riding it, and in fact doing so; this rendered the Acari very difficult to catch, as although with a glass one could keep the Gamasid in view, yet it was extremely difficult to follow the ant amongst hundreds of others. From this habit I called the creature *Laelaps equitans*. Shortly after I had announced this habit, &c., but doubtless before he knew of it, Berlese also described a Gamasid from ants' nests, which had a similar habit, and he had the same idea as mine, and actually called it *equitans*. Oddly enough the creatures, although both Gamasids, and in spite of the similar habitat and the similar habit, not known in any other species, are different creatures, and Berlese felt compelled to create a new genus for his. In 1892 and 1893 I continued these investigations in Cornwall, and found other species inhabiting ants' nests, most of which are still undescribed; but again each species of Gamasid confined itself to a particular sort of ant, and this I have found when I revisited the place after a year's interval. Amongst my Cornish species collected last autumn is one greatly resembling my Corsican *L. equitans*. I cannot say yet whether it is identical. It did not spring up upon the ants as far as I saw, but when I put it into a small saucer of water with other Acari, as I usually do in collecting or selecting Mites, instead of struggling together in a mass with their legs interlocked, as Acari generally do, this species sprang on to the other floating Acari, with the same jumping action I had seen in the Corsican nests, and sat quietly on their floating bodies. During my stay in Cornwall last autumn I observed another case of association between an Acarus and another creature which seemed to me very interesting, and which I have not hitherto recorded; I am not aware that it has hitherto been observed by any Acarologist. An ant is usually a short-tempered creature, and not one that other small living beings usually come near with impunity; still it does seem to encourage a considerable number of other minute Arthropods, such as Aphidæ, Beetles, &c., in its nest, and therefore it may not be very



startling to find Acari there. But if there be one creature more than another which we suppose to be always on the watch to devour its neighbours, and which we should think that Mites and small insects would avoid if they could, it is probably a spider; there is one called *Amaurobius ferox*, whose character does not belie its name; it lives in a silken tube, which it spins for itself under large stones, with flocculent threads round the mouth of the tube, which serve to catch its prey. I wanted some *Bdellæ* (a sub-family of Trombidiidæ), but it was late in the season, and I could not find many. I, however, found a few scattered specimens under stones on the walls of the fields. One day to my surprise I saw two or three on a web of *Amaurobius ferox*, and thought they had been caught, but I shortly afterwards found another web with some more on. When I looked at them they certainly were not caught, but ran about quite at their ease. Finally I found that this was so common that when I wanted the *Bdellæ* the best way of collecting them was to hunt for the webs of the spider. On these webs I found them of all ages and both sexes, often a great many on a single web. There were active ones and inert ones undergoing ecdysis, but, as far as I could see, the spider never touched any of them. If near the web when disturbed, they usually retreated to its shelter; they ran about it quite easily, and seemed to me to regard it as a home. It is easy to see what benefit the *Bdella* gets from the association, provided it is not eaten; it finds a home on the web, it probably is protected from its own enemies by the terror of the spider, and *Bdella* is generally supposed to be predatory, and though I cannot vouch for this, I should think that it is probably correct; if so, it doubtless gets the benefit of very small flies caught in the web, which are beneath the notice of the spider. But what benefit the spider receives from the *Bdella* is, I confess, at present entirely beyond my comprehension. The *Bdellæ* were all of one species, which was found elsewhere, but far less commonly.

One other matter which arose in my late investigations into the reproductive organs of the Gamasinæ I will mention, because you probably have not seen it in the Transactions of the Linnean Society, and it may interest you, although the whole investigation would be far too lengthy to give even a sketch of to-night. This point is the mode of coition. The male genital opening of most of the Gamasinæ is immediately behind the rostrum, and is simply a hole, not provided with any erectile or extensible intromittent organ. The form of the parts would not allow of this aperture being applied to the female; how, then, was fertilization effected? On that point there was not any reliable information. Gamasidæ mostly have very long, extremely extensible, chelate mandibles. Although those of the females show but little difference, yet in a large number of species the male mandible is entirely different, not only from the female mandible of its own species, but from the males of other species. The variations are most strange and curious, the mandible being provided with great projecting pieces of bizarre and complicated forms, some

rigid, some movable; and these mandibles form the best specific distinctions. It seemed probable that this strong sexual dimorphism had some cause; but was it primary or secondary, did it subserve actual coition, or was it like the mane of the lion? After obtaining all the anatomical information I could by dissection and sections, I endeavoured to watch the actual coition in specimens retained in confinement. It was a long time before I could find species which would copulate in confinement, but at last I found three or four species. Watching for occasions was wearisome work and when they occurred the position of the creatures was such that only partial knowledge could be obtained; I therefore tried killing the creatures instantaneously during the coitus by either boiling water or chloroform; in this way, by getting a series at various stages of the coitus, I was at last able to trace a process which seems to me little, if at all, less curious than that in spiders. The spermatozoa, when they leave the testis, are not free, but a number are enclosed within a sperm-mother-cell or spermatophore: immense accessory glands greatly increase the volume of the secretion. At the moment of coition a hollow flask-like sack is blown from the genital aperture just as a glass-blower blows a flask or a boy blows a soap-bubble; this partially sets but remains elastic; it is filled as it forms by the rush of sperm-mother-cells and mucous secretion, which sets in the end of the flask next the genital aperture, closing the flask as with a stopper. If the creatures be killed at this time the flask is in the genital aperture of the male. The male now, in most species, applies its mandibles one on each side of the flask. Just behind the chela on each mandible there is a small brush of hairs, and to these the still sticky flask adheres firmly; it is removed by the mandibles from the genital aperture of the male. If the creatures be killed at this stage, the flask will be found adhering to the two mandibles of the male; it is now applied by the mandibles to the copulatory orifice of the female; the elasticity of the flask and the pressure of the mandibles drive out the stopper, and if the creatures be killed now the empty flask will be found still adhering to the mandibles of the male, but the contents have passed into the female. The male if not killed may be seen cleaning the empty flask off its mandibles. I found an even more curious variation of this process in the case of *Gamasus crassus*; this species has an oval hole in the movable arm of the chela of each mandible, and instead of the two mandibles being applied to the already formed flask one mandible is applied by the male to its genital aperture, and the flask is blown right through the hole; the flask swells out at both ends so that it cannot come out of the hole, and in this condition the single mandible, bearing the flask threaded through the hole, is plunged right into the vulva of the female. The drawing before you was made from a mandible which I cut out of the vulva in a case where I had killed the creatures during coitus. I have mounted it as a microscopical preparation and it is still in my possession.

Finally, let us glance cursorily at the great question of phylogeny; it can only be very cursorily, for time is short. Whence have the Acarina sprung? Many eminent biologists have lately been of opinion that they are degraded Arachnida; this appears a very probable theory, but there seem to me to be certain difficulties in the way of its immediate acceptance. If the Acari were in course of degradation then we should expect, in accordance with Fritz Müller's well-known law that the ontogeny includes the phylogeny, that the larval forms would be more highly organized than the adults; but the exact contrary is the fact; in every case where there is a difference the adult is the more highly organized. The Tyroglyphidæ are about the lowest forms of free-living Acarina; they have no tracheæ or special breathing-organs of any sort; the adult Oribatidæ have unbranched tracheæ in much the same condition as those of Peripatus, only that their number and the position of their stigmata is fixed; but the immature Oribatidæ are entirely devoid of tracheæ, so that Claparède expressed it that they passed through a Tyroglyphus-stage. In *Sphærogyra* the larval forms are entirely without tracheæ and those organs exist only in the adult female; while in other Trombididæ both sexes have richly branched tracheæ. Adult Halicaridæ,\* which inhabit shallow seas, i.e. the littoral zone, are said by Lohmann to show traces of tracheal folds near the mouth; and examples might be multiplied. Again, the analogy to the Insecta has been pressed, and it has been suggested that the four pairs of legs represent the legs of an insect plus the absent labial palpi; but almost all Acari in their first larval condition have three pairs of legs only, and how does this agree with the "insects' limbs" theory? The pair that develops after the first change of skin is the fourth pair. It is true that Winkler announced the surprising discovery that in the early embryology of *Gamasus* four pairs of legs were developed, one of which atrophied before birth, to be again developed at the first larval ecdysis—a fact which, extraordinary as it is, is not entirely without a parallel in nature; but as far as it has any bearing it would speak equally in favour of a relationship to other Arachnida. I have indicated before the difficulty of finding a sufficiently clear distinction between Phalangidæ and Acarina; if a puzzling intermediate form occurs in the Acarine border-land it is sure to be on the *Phalangium* border. It seems to me that, as far as our present knowledge goes, *Phalangium* is the nearest form morphologically, but how that resemblance has been brought about is a different matter. Shall we ever be able really to decide these points? that is a question which it is beyond my power to answer; if it ever be done it will probably be when both this somewhat rambling address and its author have been long forgotten.



SUMMARY OF CURRENT RESEARCHES  
RELATING TO  
ZOOLOGY AND BOTANY,  
(PRINCIPALLY INVERTEBRATA AND CRYPTOGAMIA),  
MICROSCOPY, ETC.

*Including Original Communications from Fellows and Others.\**

---

ZOOLOGY.

A. VERTEBRATA:—Embryology, Histology, and General.

a. Embryology.†

**Experimental Embryology.**‡—Prof. G. Born has made experiments on the effects of pressure on the segmenting ova of frogs, and his results agree in many respects with those of O. Hertwig which were published after Born's communication was written. The compression was either parallel to the axis of the ovum or at right angles to it, and in some less profitable experiments the ova were compressed in a wedge shaped space. In conditions of axial compression, the first two cleavages were normal, i. e. there were two meridional cleavages crossing at right angles in planes perpendicular to the compressing plates. The third cleavage should be horizontal, but instead of this there appeared on the upper side of the ova two vertical cleavages, one on each side of the first, and more or less parallel to it. The cleavages of the fourth order were again vertical, approximately parallel to the plane of the second cleavage. In conditions of lateral compression, the first cleavage ran from dark to clear pole perpendicular to the direction of the compressing plates. There were slight deviations from the perpendicular, as Pflüger observed in similar conditions. The second cleavage was always horizontal, and again at right angles to the compressing plates, at the boundary between the median and upper third of the axis of the ovum. The cleavages of the third order began in the two upper small cells, usually as two

\* The Society are not intended to be denoted by the editorial "we," and they do not hold themselves responsible for the views of the authors of the papers noted, nor for any claim to novelty or otherwise made by them. The object of this part of the Journal is to present a summary of the papers *as actually published*, and to describe and illustrate Instruments, Apparatus, &c., which are either new or have not been previously described in this country.

† This section includes not only papers relating to Embryology properly so called, but also those dealing with Evolution, Development and Reproduction, and allied subjects.

‡ Anat. Anzeig., viii. (1893) pp. 609-27 (10 figs.).



vertical partitions parallel to the first; those of the lower half were uniformly vertical and parallel to the first cleavage plane. Those of the fourth order varied according to the direction of the third cleavages in the upper cells. Prof. Born discusses the problems which are raised by these observations on abnormal segmentation.

Dr. W. Roux\* discusses Prof. O. Hertwig's recent investigations on the first cleavages of the frog ovum and their relations to organogenesis. He points out several sources of error in Hertwig's work and dissents from his conclusions, holding firm to his own interpretation of the first cleavages as qualitative partitions of the material which serves for the direct development of the four quarters of the embryo.

**Ectodermic Origin of Skeletal Rudiments.**†—Herr N. Goronowitsch complains that Miss Platt has not done justice to his prior research on the ectodermic origin of certain skeletal rudiments in the head of Vertebrates. Moreover, while Miss Platt states that ectodermic structures may be directly modified into cartilage, Goronowitsch maintains that the most one can say is that ectodermic proliferations give rise to skeletal rudiments of a connective tissue nature which become subsequently in part differentiated into cartilage. An ectodermic proliferation (behind the eye) which Miss Platt interpreted as indicative of a lost gill-cleft, and also connected with the basis in which the pterygo-palatine process develops, has nothing to do with either. It is "Froriep's rudiment" in the region of the trigeminal.

**Human Embryo of Second Week.**‡—Prof. F. Mall describes a human embryo 10 mm. by 7 mm., apparently of the second week. He made sections and a reconstruction. The embryonic vesicle is attached to the chorion by a stem, and is composed of two layers between which, at a distance from the stem, there are indications of blood-vessels or a middle embryonic layer. Just beside the attachment of the vesicle to its stem there is a deep and short invagination of both layers. The author believes the specimen shows an inversion of the membranes, and that the invagination is the cavity of the amnion.

**Development of Hypophysis Cerebri in the Domestic Cat.**§—Mr. F. S. Aby, after a review of the very different senses in which the term pituitary body is used, comes to the conclusion that it is not synonymous with hypophysis cerebri, and should not be used for it; nor should the term infundibulum be used for processus infundibuli. The sinus known as Seessel's pocket has an epithelial lining which is only one cell in thickness; that lining the first signs of the hypophysis is several cells thick. The projection between the pocket and the hypophysis is formed by a proliferation of mesoblastic cells, and is not, necessarily, the remains of the oral invagination, although it indicates its position. The anterior end of the notochord is in close connection with this nest of cells, and does not approach the hypophysis cerebri. The epiblast which lines the encephalon and that which lines the stomodæum lie in close contact in the region of the hypophysis. This last is developed from epithelium

\* Anat. Anzeig., viii. (1893) pp. 605-9.

† Morphol. Jahrb., xx. (1893) pp. 425-8.

‡ Anat. Anzeig., viii. (1893) pp. 630-3 (2 figs.).

§ Bull. Laborat. Nat. Hist. Univ. Iowa, ii. (1893) pp. 295-310 (4 pls.).

on the cephalic side of the oral plate, and is, therefore, of epiblastic origin, as is also the processus infundibuli. Both of these outgrowths are the direct result of cell-proliferation. When further developed and united the two form the structure known in adult mammals as the pituitary body, and are assisted by the proliferation of cells from the mesoblast.

**Development of Wolffian Body in Chick and Rabbit.\***—Prof. J. B. Haycraft has a preliminary notice of his investigations. The first sign of the developing duct is a solid growth, which only later becomes differentiated from the rest of the mesoblast, and which runs in the length of the embryo. It is joined at each segment to the walls of the body-cavity by equally solid columns of cells—the primitive segmental tubules. The author can find no evidence that the tubules form first, and then join the Wolffian duct, as has been frequently described. A central cavity appears to be formed between the cells. It sometimes happens that, in a section, a tubule is seen with apparently a free end detached from the duct; this is because the tubules bend, and are often cut across at a bend; if these tubules are traced out in other sections of the series they can invariably be traced to the duct. Prof. Haycraft finds that there are no secondary tubules arising from those first formed, in the chick or rabbit, though, it is true, they have often been described.

**Dentition of Pinnipedia.**†—Prof. W. Kükenthal gives an account of the development of the teeth in the walrus and the seal. In the foetal walrus the dental formula is  $\frac{3-3, 1-1, 3-3, 2-2}{3-3, 1-1, 3-3, 1-1}$ .‡ Two of the incisors above and three below disappear, the permanent lower canine becomes like a premolar, the upper forms the well-known tusk, the three premolars are replaced, the molars disappear. Thus the formula for the adult dentition is  $\frac{1-1, 1-1, 3-3}{0, 1-1, 3-3}$ . There is in the walrus, when compared with other Pinnipedia, a characteristic shortening of the jaw, in adaptation, the author thinks, to the habit of mussel-crushing instead of fish-catching, and the well-worn appearance of the premolars is due to the fact that the upper and lower teeth grind against one another and do not alternate as in other Pinnipedia. In consequence of the shortening of the jaw there is in the upper jaw a fusion of the two molar rudiments, which are originally quite distinct.

Of the seals, *Phoca groenlandica* has been especially investigated. The milk dentition, almost wholly absorbed in intra-uterine life, is  $\frac{3-3, 1-1, 4-4}{2-2, 1-1, 4-4}$ , with two molars, which, according to Kükenthal, belong essentially to the first set. The adult dentition is  $\frac{3-3, 1-1, 5-5}{2-2, 1-1, 5-5}$ . The lateral tubercles of the back teeth are late in developing. Hints of no less than four successive dentitions are found.

\* Anat. Anzeig., xi. (1893) pp. 75-9 (6 figs.).

† Jenaische Zeitschr. f. Naturwiss., xxviii. pp. 76-118 (2 pls.).

‡ It seems to us that in the formula on p. 92 there should be three incisors instead of two.

**Dentition of Wombat.\***—Dr. C. Röse finds that *Phascolumys Wombat* in the foetal state has a double set of teeth—a rudimentary milk-set of limited growth, and a permanent set with prismatic teeth. The teeth of the first set, to which perhaps there belongs a non-calcified premolar rudiment, are probably in part absorbed before they cut, or else they fall out in early youth. Of the incisors of the second series two must have been lost from the upper jaw, and one from the lower jaw.

**Ganglion Ridges in the Head of Birds.†**—Herr N. Goronowitsch begins by noting that the so-called ganglion-ridges (*Ganglienleisten*) are most strongly developed on that part of the embryonic head on which no ganglia develop, namely, in the mid-brain region. Difficulties of this sort led him to reinvestigate the matter. As regards trout and pike he has convinced himself that the entire strongly developed portion of the ridges, in the thalamencephalic and mesencephalic regions, has nothing to do with the development of ganglia and nerves. It forms mesenchyme tissue, connective and probably skeletogenous. The same is true for birds.

We cannot follow the author in his description of the state of affairs in twenty-seven stages in the development of the chick, but some general results may be noted. Goronowitsch distinguishes as primary ridges those which appear first in the region of the thalamencephalon and mesencephalon; secondary and tertiary ridges appear later in the region of the medulla oblongata. For the bird, as for Teleostei and Selachii, it is the case that the ectoderm shares in the formation of mesenchyme tissue, for this is the fate of the whole of the primary ridges. The medullary plate must be regarded as a composite *Anlage*, for it gives origin to things so different as the central nervous system and various structures of a connective-tissue nature.

In the formation of the secondary ridges, the ectoderm and the medullary plate have an equal share. The secondary ridge in birds is never so strongly developed that it could produce the whole, apparently unified, mass of tissue which unites the dorsal arch (*Gewölbe*) of the medullary canal with the "branchial sense-organs." The structure which has been interpreted as the rudiment of a nerve or ganglion passes without break into the axial mesoderm and fuses with the middle plate. The so-called "branchial sense-organs" of early stages represent the points of fusion of the most heterogeneous structures, and soon disappear. The connection of the arch of the medullary tube with the middle plates in the region of the second and third somites occurs through the formation of a tissue-strand, which, like the secondary ridges, is formed from two sources, the tissue of the ridge and the mesoderm arising from a proliferation of the middle plate. This strand the author calls the "second periaxial strand." The "first periaxial strand," which appeared at an earlier stage, established a similar connection between the arch of the medullary tube and the middle plate. Goronowitsch follows the modifications of the periaxial strands and describes the incipient stages of the trigeminus, facialis, glossopharyngeus, and vagus. The appearance of the strands is contemporaneous with the development

\* SB. Preuss. Akad. d. Wiss., 1893, pp. 749-55 (3 figs.).

† Morphol. Jahrb., xx. (1893) pp. 187-259 (4 pls.).



of the visceral arches, with which they have more to do than with the nerves. It seems as if in higher Vertebrates the periaxial strand had a diminishing share in forming the nerve-bearing tissue. The nerve-bearing tissue of the facial in birds is wholly due to the periaxial strand, that of the glossopharyngeal is partially so, that of the vagus not at all.

**Development of Teeth in Iguana.\***—Dr. W. Leche has made some observations on a large number of well-preserved embryos and young of *Iguana tuberculata*. In an embryo twenty-four days old he found the first rudiments of the teeth; these differed from those that appeared later by their smaller size, their superficial position, and their want of function, as they disappear long before birth. The second dentition of *Iguana*, as of other Saurians, differs, first of all, from that of Mammals in that the rudiment of the tooth is much further developed before it is “emancipated” from the enamel ridge.

**Development of Gill-pouches and Aortic Arches in Chelonia.†**—From a study of *Chelonia viridis*, Dr. J. F. van Bemmelen comes to the following conclusions:—

(1) The first formation of gill-pouches and aortic arches in Chelonians agrees completely with that of Lacertilia and Ophidia, but their further development is more like that of Birds than of other Reptiles.

(2) There are primitively five pouches and six arches, and, in addition, there is developed from the hinder wall of the hindermost pouch a pair of pocket-like evaginations, as in Snakes.

(3) The three anterior pouches are without doubt open for a short time, and it is probable that the same is true of the fourth pouch.

(4) The first, as in other Amniotes, gives rise to the Eustachian tube; the outer opening soon closes.

(5) The dorsal tip of the second pouch widens out into a follicular epithelial bud; as in Birds the second pouch aborts in the course of development.

(6) The backward growth of the gill-arches causes the outer cleft-like opening of the most anterior pouch to be pushed far back, and a long thin canal results.

(7) The third pouch enlarges into an epithelial follicle with a number of secondary outgrowths; this becomes constricted off from the branchial enteron, and the enlargements are converted into thymus-tissue, in the interior of which the central epithelial follicle persists.

(8) The fourth and fifth pouches give rise to processes which retain their epithelial character.

(9) The aorta is developed from the fourth gill-arch artery, and the pulmonary artery from the sixth; the fifth early becomes aborted.

**Maturation and Fertilization of Egg of Axolotl.‡**—Prof. R. Fick finds that the eggs of the *Axolotl* vary considerably in size. The “clear directive spot” is not identical with the “directive pit” or fovea germinativa, for the latter is a pit in the surface of the egg, secondarily formed by the pressure of the first polar globule. The egg has two yolk-membranes, the outer of which is thick and derived from the follicular

\* Anat. Anzeig., viii. (1893) pp. 793-800 (7 figs.).

† Tom, cit., pp. 801-3.

‡ Zeitschr. f. wiss. Zool., xlvi. (1893) pp. 529-614 (4 pls.).



epithelium, while the inner, which is delicate, is the cell-membrane of the egg. The cavity around the germinal vesicle does not appear to be an artificial product. A large number of forked chromosomes are to be found in the germinal vesicle. The nucleoli disappear when the chromosomes give rise to the first directive spindle. As the ovum matures, the germinal vesicle migrates to the surface of the egg. The first polar globule has about eight chromosomes. The first spindle appears to be formed from the remains of the germinal vesicle, and no polar rays or centrosome can be seen in it. The first spindle is primarily tangential in position, and then radial. When it is radial its fibres are attached to the cell-membrane of the egg, and to the plasmatic network of the egg-cell. The first polar globule is expelled as the egg passes from the ovary into the oviduct, or in the uppermost portion of the latter. The two directive divisions are true cell-divisions; and the two cells lie between the yolk-membrane and the egg-cell-membrane. The second spindle is derived without any period of repose from the first, is much smaller than it, and, like it, has no signs of polar rays or centrosome. The second cell is not expelled till after fertilization. In its migration the ovarian nucleus, which contains neither spheres nor centrosomes, grows very considerably.

The spermatozoon consists of head, connecting-piece, and tail; in the head a Retzius' spear, a special anterior piece, and an axial filament can be made out; the connecting-piece consists of an axial filament and a mantle; with metallic salts and hæmatoxylin it is stained a deep blackish blue. The tail has an axial filament and mantle, as well as an undulating membrane, and a specially formed terminal piece; the membrane is attached on one side only, and not spirally.

At the point where the spermatozoon enters the egg there is formed a funnel-shaped or conical aggregation of ovarian plasm, and the whole of the spermatozoon passes into the egg. From the connective piece of the spermatozoon an attraction sphere is developed, and from the head the spermatoc nucleus is formed, while the tail disappears completely. This nucleus migrates and exhibits amœboid movements, while it increases considerably in size.

In the Axolotl there is physiological polyspermy; the subsidiary spermatozoa behave exactly like the chief spermatozoon, but they do not copulate with the ovarian nucleus.

**Ontogenetic Differentiations of Ectoderm in *Necturus*.**\* — Miss J. B. Platt has studied the development of the neural crest in *Necturus*, and finds that it presents some differences from what obtains in the Bird. The neural crest arises in two, not three, divisions, and each contributes directly to the formation of the peripheral nervous system. They do not constitute merely a nerve-supporting tissue, but give rise to ganglion-cells which "spin" motor as well as sensory fibres. Cells arising from the ectoderm and endoderm respectively are distinguished from one another, until a late stage of embryonic development, by the yolk-globules they contain; for this purpose the use of the triple stain known as Biondi-Ehrlich may be recommended. There is no homogeneous tissue composed of cells wandering from the neural crest, ectoderm

\* Anat. Anzeig., ix. (1893) pp. 51-6 (3 figs.).

and axial mesoderm, and there is, therefore, no homologue of the "periaxial Strang." Wandering cells from the neural crest and ectoderm give rise to the cartilage of the head, and may contribute to the formation of certain other tissues; but there does not seem to be any evidence that they take part in the formation of the "cutis."

**Experimental Studies on Eggs of Teleosteans.\***—Prof. T. H. Morgan, who has experimented with the pelagic eggs of *Otenolabrus* and *Serranus*, and with the large eggs of *Fundulus*, applied the method of Pflüger, Roux, and others; he has also tried to test by experiment the theory of concrescence of the embryo. After removing one of the first two blastomeres, he found that the resulting embryo was larger than half the normal embryo, but not so large as the whole. In the egg operated on there remains half the segmentation-nucleus, more than half of the protoplasm, and all the yolk; there results an embryo of nearly two-thirds the size of the normal. The author thinks the conclusion seems to follow that the size of the embryo is determined by the amount of protoplasm present, and not by the quantity of nuclear matter. If the first cleavage results in unequal blastomeres, the embryo is smaller when the smaller half is left, and larger when the larger remains.

From experiments made by removing the yolk we find, to state matters generally, that the egg of *Fundulus* is able to adapt itself to most unusual conditions, and still produce an embryo that is distinctly that of *Fundulus*. The author suggests that this points to the conclusion that, while the egg during development adapts itself to the necessities of the occasion, by utilizing the mechanical means placed at its disposal, it is a mistake to suppose that the external conditions determine the series of phenomena, for the same result follows even when the primary conditions are very much altered.

In the study of concrescence two points had to be tested—is the head a fixed point, and does the substance of the germ-ring go to make up the embryo? He finds that the embryo, cut off from all connection with the germ-ring on one side, elongates backwards and produces an embryo in which the right and left sides are alike and equal. From this he concludes that, in the elongation of the embryonic knob backwards, the head remains a fixed point, and the elongation is due to an extension backwards of the mass; the germ-ring takes no important part in the formation of the embryo.

**Growth of Blastoderm in Teleosteans.†**—MM. R. Koehler and E. Bataillon have studied on eggs of *Leuciscus jaculus* the vexed question of the mode of growth of the blastoderm. Their observations lead them to support the views of Kuppfer, for they find that the opaque region remains fixed at the germinal pole, while the blastoderm extends regularly over the vitellus; as it does it describes circles which are more or less exactly parallel to the equator of the egg. When the blastoderm covers half the egg the first rudiment of the embryo is differentiated in the form of a small shield on its thickened edge. While the blastoderm continues its development the embryonic rudiment elongates; when the yolk is almost entirely covered with the blastoderm,

\* Anat. Anzeig., viii. (1893) pp. 803-14.

† Comptes Rendus, cxvii. (1893) pp. 490-3.

and there is only a small blastopore, the embryo has the form of a delicate line which extends from the blastopore along half a meridian of the egg. As Kuppfer and some later observers have noticed, the vitelline pole is not placed exactly at the pole opposite to the germinal pole, but is to the side of the vertical axis of the egg.

So far as concerns the time of appearance of the different organs *Leuciscus* does not agree with the Salmonidæ, which are generally taken as the type of development of Bony Fishes.

**Karyokinetic Phenomena in Cells of Blastoderm of Teleosteans.\***  
—MM. E. Bataillon and R. Koehler find that sections, stained with boracic methylene-blue, of eggs eight days after fertilization present fine karyokinetic figures; the chromatin always exhibits marked selection of this stain; if eosin be used after the methylene-blue the nuclear granulations in a state of repose will be found stained by it. From these observations the authors conclude that, in these conditions, methylene-blue is a true reagent for chromatin in movement, and that, with the exception of the nucleoli, the granulations of the nucleus which are in repose have not the same reaction as the chromatin in division; they must, therefore, change their chemical composition when they enter into the constitution of the filament.

In the early stages of development of *Leuciscus jaculus* the blastodermic cells do not exhibit any individualized chromatin, and the karyokinetic figures are exclusively formed of achromatic elements. This important fact supports the opinion based on the most recent researches that, in the cell, the essential rôle does not belong to the chromatin, as has been hitherto supposed, but to the centrosomes. Chromatin exists at first in a diffused state in the protoplasm, as several authorities have already asserted. It is differentiated and individualized in this protoplasm in the form of colourable granulations; and afterwards it becomes incorporated with the nuclei to form the equatorial plates which are absent from the first stages.

**Vertebral Column of Fishes.†**—Dr. H. Klaatsch finds around the notochord of dogfish embryos a double sheath, an inner, thicker layer, and a thin outer refractive membrane. This ontogenetic stage represents, as Schneider recognized, the permanent state of Cyclostoma and of the cartilaginous Ganoids. The inner perichordal membrane is the notochordal sheath, a secretory product of the peripheral notochord cells; the outer represents the elastica, probably due to perichordal tissue. The common ancestral type of all living fishes had around a cellular notochord a non-cellular fibrillar sheath, and outside this a strong elastic membrane. There is no reason to refrain from collating the vertebral arches of *Amphioxus* with those of Craniota. There is a fundamental similarity throughout; in the primitive fishes cuticular fibrillar arches arose similar to those in *Amphioxus*; “in the inheritance of the possession of these arches we see the reason for the marked differentiation of the skeletoblastic sheath in all fishes.” As primitive possessions the author also claims the longitudinal dorsal ligaments and the ventral ligament. But we cannot do more than indicate the lines along which Herr

\* Comptes Rendus, cxvii. (1893) pp. 521-4.

† Morphol. Jahrb., xix. (1893) pp. 649-80 (1 pl., 1 fig.).



Klaatsch has been working towards a reconstruction of the original vertebral column.

The same author\* draws a sharp distinction between the perichordal and the chordal origin of vertebræ. In the perichordal mode, described by Gegenbaur, and Balfour and Parker for *Lepidosteus*, a continuous cartilaginous tube surrounding the notochord becomes by segmentation divided into vertebræ. The elastica and the non-cellular sheath play no part. In the chordal mode, which the author describes in detail, relations are established between the cartilaginous arches and the elastica; as a closed membrane the latter disappears; the notochord-sheath is opened up to, and invaded by the cartilage; there is a competition of elements, and the cartilage gains the day. Along these two lines of perichordal and chordal evolution, the vertebral column of fishes has evolved. On the one (perichordal) line we have the Cyclostoma, Teleostei, *Lepidosteus*, and *Acipenser*; on the other (chordal) line, we have Dipnoi, Holocephali, and Elasmobranchs.

**Origin of Vascular System in Selachii.**†—Prof. C. K. Hoffmann has investigated this in embryos of *Acanthias vulgaris*, and finds that the endothelium of the entire vascular system arises from hypoblast. In fact, heart, aorta, omphalo-mesenteric veins, truncus arteriosus, &c., are constricted off from the archenteron. The development of the heart and aorta is introduced by a remarkable "struggle for life" among the hypoblast cells of the archenteric wall; and in this struggle a multitude of cells perish. Many of the survivors, destined to become endothelial, exhibit a modification into long spindle-shaped elements; others have numerous exceedingly fine processes and often form chains or a meshwork. This peculiarly modified archenteric epithelium the author calls hæmenchyme-tissue; most of it becomes endothelium, while some elements seem to become blood-cells. But the most important result is the general conclusion stated above that the endothelium of the vascular system is entirely hypoblastic.

Prof. C. K. Hoffmann continues † his investigation of the development of the venous system in Selachians. It is likely that ancestral forms had two omphalo-mesenteric veins, but in extant forms the right vein is represented merely by two rudiments, an anterior portion opening into the sinus venosus, and a smaller posterior portion which unites with the left vein. The posterior part soon aborts; the persistent anterior portion subsequently unites *dorsally* with the left vein directly behind the pancreas. A second *ventral* anastomosis forms a venous ring around the gut. Later on the mesenteric vein (the sub-intestinal of the trunk) unites with the left omphalo-mesenteric vein and forms a second venous ring. Thus the Selachians are shown to agree in an important respect with the Amniota, in all of which there are two such venous rings.

In the sub-intestinal vein, two portions must be distinguished, the caudal and the trunk portion. The former loses connection with the latter, and unites with the cardinal veins. But there is a third portion,

\* Morphol. Jahrb., xx. (1893) pp. 143-86 (1 pl., 6 figs.).

† Op. cit., xix. (1893) pp. 592-648 (4 pls., 6 figs.).

‡ Op. cit., xx. (1893) pp. 289-304 (1 pl.).



which lies between the future mid-intestine and the beginning of the tail, and has an interesting history. It loses connection with the other parts and becomes modified into "hæmenchyme" tissue, absolutely resembling the adenoid or reticular connective tissue from which the submucosa arises.

Prof. Hoffmann had previously concluded that the cardinal veins were direct diverticula of the sinus venosus. But this is true only of the common cross stems, by which the anterior and posterior cardinals join the sinus venosus. The cardinal veins arise as segmental diverticula of the aorta which form a blood-sinus around each cranial and spinal nerve. Of these diverticula the proximal portions may be regarded as arteries, the distal portions as veins, and it is from the fusion of the latter that the cardinal veins arise. As both the sinus venosus and the aorta arise from the archenteron, the same is now shown to be true (though more indirectly) for the duct of Cuvier and the cardinal veins.

**Maturation of the Ovum of the Lamprey.\***—Herr K. V. Herfort believes that all who have previously investigated the fertilization of the ovum in the lamprey have failed to discover the true germinal vesicle and polar bodies. The mature but unfertilized ovum shows (1) a thin layer of formative plasm or pole-plasm at the animal pole, (2) an alveolar cortical zone, (3) a lateral insinking of the periphery containing the first polar body and showing beside this a spindle and a distinct radiation, (4) an outer denser vitellus, and (5) an inner looser vitellus. Immediately after fertilization the pole-plasm shows the well-known amoeboid protrusion between the ovum and the surrounding membrane, the alveolar cortical zone disappears; laterally in the yolk and at some distance from the periphery lies the spindle; the first polar body has degenerated and the depression in which it lay vanishes. The second polar body is smaller than the first, and lasts longer. What Kupffer and Böhm called the polar bodies are hyaline protrusions of the pole-plasm artificially separated.

### β. Histology.

**Minute Structure of the Cell.†**—Dr. F. Reinke is enthusiastic in regard to the results of using his lysol method. He confirms the observations of others as to (1) the likeness between nucleoli and nuclear membrane, (2) the reticular structure of the nuclear membrane, and (3) the complicated structure of the so-called nuclear sap (*Kernsaft*) which seems often to consist of threads with enclosed granules. He corroborates previous hypotheses, e. g. the existence of polar areas in the structure of the resting nucleus. New results are also attained, especially this, that each kind of tissue is characterized by a specific differentiation of the nuclear structure.

**Interactions between Cell-substance and Nucleus.‡**—Dr. W. Roux noted some years ago that the form of the protoplasmic masses within the cell had a directive influence on the nuclear spindle. In the course of his researches in experimental embryology he has gathered some fresh facts. The materials of the cell-substance are disposed in relation to

\* Anat. Anzeig., viii. (1893) pp. 721-8 (7 figs.).

† Tom. cit., pp. 639-46.

‡ Zool. Anzeig., xvi. (1893) pp. 412-6.

the direction and nature of the nuclear division; in other words, the differentiation of the cell-substance shows itself in certain cases markedly dependent on the nucleus. In abnormal cases of modified frog ova the nucleus shows a striking independence of the cell-substance. The segmentation nucleus of the punctured half of the ovum may divide repeatedly and change qualitatively although the yolk takes no share. The nuclei may cause a series of cytoplasmic changes, far from normal, indeed, eventually pathological.

**Nucleus and Protoplasm.\***—Dr. M. Heidenhain has made his observations chiefly on sections stained with acidified Ehrlich-Biondi's mixture. He found in the cell-nucleus, in addition to the chromatic framework and the nucleoli, a chromophilous substance which he calls Lanthanin. This is deposited in the form of small spheres of closely webbed fine threads which are made visible by being stained with rubin.

He finds that the centrosomes in cells with resting nuclei are always double, that the attraction-sphere surrounding is sharply separated from the rest of the protoplasm by Van Beneden's granular stratum, and that, in many cases, a radiate structure can be distinctly made out. In the rest of the cytoplasm there appears to be a filamentar structure, and most filaments can be more or less distinctly seen to be made up of separate microsomes.

**Structure of Reticulated Tissue.†**—M. L. Demoor finds that the structure of adenoid tissue is always the same, whatever be the organ in which it is studied. It is formed by the anastomosis of cells provided with prolongations, and these cells, both in their nucleus and their protoplasm present characters which are sufficiently constant to allow, in most cases, of the differentiation of the elements enclosed in the network. Beside these characteristic elements, other cells (polycaryocytes and megacaryocytes) may come into relation with the plexus by their prolongations, and so contribute to its extension. The development of the reticulated framework may be effected by direct division of the cells which constitute it. All the varieties of leucocytes as yet described may be met with in the meshes of adenoid tissue. The giant-cell with budding nucleus is not a characteristic of hæmatopoetic organs, for it may be met with in the lymphatic ganglion of young animals.

**Behaviour of Pigment-Granules during Karyokinesis.‡**—Dr. J. Nusbaum in studying embryos of the frog observed in many entoblast and mesoblast cells an interesting distribution of the brownish-black pigment-granules. During the spindle stages the granules are mostly peripheral, but as the daughter stars diverge they collect in the equatorial plane, forming first a ring, then a disc, and then a thick plate. In the middle of this plate a thin unpigmented space appears, and the granules diverge towards the poles. Finally, the original distribution throughout the plasma is restored. Nusbaum compares the formation of the equatorial plate to Flemming's "Zwischen-

\* Festschrift zum 50-jährig. Doctorjubiläum von v. Kölliker, Leipzig, 1892, pp. 111-66 (3 pls.). See Bot. Centralbl., lv. (1893) pp. 156 and 7.

† Arch. de Biol., xiii. (1893) pp. 1-40 (2 pls.).

‡ Anat. Anzeig., viii. (1893) pp. 666-8 (5 figs.).

körperchen" and to the "cell-plate" in vegetable cells; all are at least phenomena due to intracellular forces exerted in karyokinesis.

#### γ. General.

**Chemistry of Protoplasm.\***—Herr G. Wendt has an important essay on this subject, in which he advocates "the theory of the specific individual capillary reactions of the protoplasm." A preliminary statement of this was published by Preyer and Wendt in 1891. So far as we have been able to follow the author in his terse discussion of a most difficult problem, we find (1) a sharp contrast drawn between inorganic and vital chemical reactions, the uniqueness of the latter depending on the capillary peculiarities of protoplasm; (2) a contrast between phytoplasma, which is especially the seat of synthetic (*Kondensations*) and reducing processes, and zooplasma, which is especially the seat of analytic and oxidizing changes—a contrast dependent on the possession of different capillary forces or "colligative" properties; (3) a destructive criticism of the micellar or tagma theory of the constitution of protoplasm, against which the author believes that the chemical objections are fatal; and (4) a recognition of the results of morphological investigations which disclose the existence within the cell of capillary spaces disposed in definite specific order.

### B. INVERTEBRATA.

**Parasites of Holothurians of Naples.†**—Signor F. S. Monticelli found an *Agamonema* in the body-muscles of *Synapta*, which is probably sexually mature in Plagiostomous Fishes; *Ctenodrilus pardalis* was found in the coelom of *Synapta* and *Holothuria*; *Anoplodium pusillum* sp. n. in the coelom of *H. Poli*; *Ophryotrocha puerilis*, a Polychæte, in the coelom of *Cucumaria Planci*. Free-living Copepoda, Nematoda, Oligochæta and Foraminifera were—in consequence of the peculiar ingestion of water by Holothurians—recognized in their body-cavity.

#### Mollusca.

##### a. Cephalopoda.

**Cephalopoda of North Sea.‡**—Dr. A. Appellöf, in a short account of the Cephalopods collected by the Norwegian North Sea Expedition, calls attention to the occasional absence of the ink-bag, and asks whether there is not a group of species distinguished by the absence of this organ. In the young stages of *Gonatus Fabricii* the suckers do not exhibit any signs of hooks, but have only distinctly dentated chitinous rings.

**Inhibition in Cephalopoda.§**—M. C. Phisalix has observed that pallor of the chromatophores of Cephalopods may result from the action of certain stimuli. His experiments show that excitation of the supra-oesophageal ganglion by a feeble current often produces extreme pallor; it is probable that this is due to a reflex phenomenon rather than to

\* *Jenaische Zeitschr. f. Naturwiss.*, xxviii. (1893) pp. 53-75.

† *Monit. Zool. Ital.*, iii. (1892) pp. 248-56. See *Centralbl. f. Bakteriöl. u. Parasitenk.*, xiv. (1893) p. 645.

‡ *Bergens Mus. Aarbog for 1892* (1893) No. 1, pp. 1-13 (1 pl.).

§ *Comptes Rendus*, cxvii. (1893) pp. 638-40.



excitation of the cerebral surface. It appears to be clear that there are in the circumoesophageal ganglia chromato-constrictor centres which, when put into activity, can paralyse the chromato-dilatator centres. In all the experiments where chromato-constriction had been suppressed, the cerebral ganglia had been first made unable to act.

It may, therefore, be concluded that the inhibiting centres of the chromatophores are localized in the cerebral ganglion, and that it is the direct action of these centres on the chromato-dilatators that produces the momentary paralysis of the dilating muscles, and the resulting pallor.

For chromatophores, as for blood-vessels, the inhibition of the muscular fibres is not effected directly, but by the intermediation of nerve-centres.

**Bilateral Hectocotylyzation in *Eledone cirrhosa*.**\*—Dr. A. Appellöf calls attention to a specimen of this Cephalopod, in which the third arm on the left as well as on the right side is hectocotylyzed. It is exceedingly rare for more than one to be thus modified, but there are, in the case under consideration, no other abnormalities either in the arms or in the reproductive apparatus.

#### γ. Gastropoda.

**Neotænioglossæ.**†—Herr B. Haller describes *Triton*, *Dolium*, *Strombus*, and other "longicommissurate" Neotænioglossæ of the "Vettor Pisani" collection. The general characteristic is the length of the cerebro-pedal, pleuro-pedal, supra-intestinal, and sub-intestinal commissures. The most primitive family is the Tritonidæ, with the genera *Ranella*, *Triton*, and *Persona*. As chief characteristic of the family the author notes the elongated pedal ganglia. The Dolidæ come next, between Tritonidæ and Strombidæ, characterized by the complete fusion of cerebral and pleural ganglia and by the strong development of the fore-gut. The genus *Cassidaria* is more primitive than *Dolium*. In the family Strombidæ there is a striking structural similarity between *Strombus* and *Rostellaria*, and the genus *Xenophorus*, which the author previously placed near Naticidæ, must be included here. The Pteroceridæ seem to be nearly allied to Strombidæ, but the author has only investigated the nervous system of *Ctenopus*.

**Absence of Male Reproductive Organs in Two Hermaphrodite Molluscs.**‡—Mr. W. E. Collinge has found in two species, normally hermaphrodite, viz. *Helix aspersa* and *Arion intermedius* (?) an absence of male reproductive organs, and he urges that these facts should be considered in view of the generally accepted doctrine that hermaphroditism was the primitive state among multicellular animals.

**Dorididæ.**§—Dr. R. Bergh has some critical notes on *Doris stellata* Cuv., with which *Jorunna Johnstoni* is identical, and gives an account of its anatomy. A full account is given of *D. acutiuscula* which has scarcely been mentioned since the time of Möller; there are also anatomical notes on two species from Port Jackson first described by Anga:—*Chromodoris Bennetti* and *C. festiva*.

\* Bergens Mus. Aarbog for 1892 (1893) No. 1, p. 14.

† Morphol. Jahrb., xix. (1893) pp. 553-91 (4 pls.).

‡ Journ. Anat. and Physiol., xxvii. (1893) pp. 237 and 8.

§ Abh. Zool. Bot. Ges. Wien, xliii. (1893) pp. 408-20 (1 pl.).



*Siphonaria*.\*—Dr. A. Köhler has made a close examination of this Mollusc, and tries to ascertain its exact systematic position, whether with the Pulmonata or Tectibranchiata. With regard to the gill of *Siphonaria*, it has been held by various authorities that (1) it is not homologous with the ctenidium or true Molluscan gill, but is a neomorph; (2) it corresponds to a series of ctenidia, and that each of the "gill-lamellæ" is homologous to a complete ctenidium; (3) the whole gill of *Siphonaria* corresponds to a single ctenidium.

The gill, as to which these very divergent views have been propounded, consists of a series of folded plates which often carry secondary lamellæ; these plates correspond exactly in structure and position to the gill-plates of *Umbrella* or *Pleurobranchus*; they do not arise from an axis, but directly from the roof of the respiratory cavity, just as the anterior gill-plates of *Umbrella* arise from the side of the body. The opisthobranch *Lobiger* has, according to Mazzarelli, a pectiniform gill exactly like that of the young *Siphonaria*. While the gill of this Mollusc may, in its structure, be easily allied to the gill of Pleurobranchidæ, its position, on the other hand, is exactly that which obtains in the Tectibranchiata with well-developed respiratory cavity, e. g. *Bulla*. The differences in the arrangement of the organs which occupy the roof of the respiratory cavity in *Siphonaria* and in most of the Cephalaspideæ appear to be chiefly due to the movement of the heart towards the left, and a prolongation of the gill towards the same side. The distance of the auricle from the gill is thereby increased, and the vessels that return the blood to the heart are broken up into two sets.

The agreements between the gill of *Siphonaria* and those of Tectibranchs seem to the author to show that we have to do with homologous organs, and this view is supported by the innervation of the parts. After a comparison with *Umbrella*, Dr. Köhler expresses his conviction that the gill of *Siphonaria* is a true ctenidium, and not a secondary neomorph due to adaptation to a special mode of life. From this it seems to follow that the genus in question is a true Opisthobranch and not a Pulmonate. Moreover, the nervous system of *Siphonaria* has a great resemblance to that of *Umbrella*, while the generative organs show points of affinity to the Bullidæ.

**The Oncidiidæ.**†—In his second contribution to our knowledge of the Pulmonate Gastropods Dr. L. H. Plate discusses the characters of *Oncidium* and its allies. He is of opinion that the Oncidiidæ form an aberrant side-branch of the stem-form of the Pulmonata, and are therefore to be regarded as primitive forms, notwithstanding such secondary modification as the loss of the shell. From these primitive forms arose first the Basommatophora and later on the Stylommatophora.

The author gives a number of reasons for regarding the Oncidiidæ as Pulmonata and not Opisthobranchiata; he urges that the cavity which serves for respiration is a true pulmonate lung-cavity in the morphological sense, and brings forward evidence in support of this position. There is a close similarity between their central nervous system and that of the Limneæ; the generative organs are really of the Pulmonate type; while, as in that group, the kidney has a lamellar structure, and there is a similarity in position. There is a pedal gland in the

\* Zool. Jahrb. (Anat.), vii. (1893) pp. 1-92 (6 pls.). † Tom cit., pp. 93-234 (6 pls.).

Oncidiidæ, but not in the Opisthobranchiata, while there is no blood-gland, which is very frequently present in Opisthobranchs. Though of less significance, the enteric canal speaks also to the Pulmonate nature of the Oncidiidæ.

If we allow their Pulmonate nature, we find that the forms under discussion are much nearer the Basommatophora than the Stylommatophora. After pointing out the characters in which they agree with the former, he argues against the value of the points in which they resemble the latter.

He concludes that the tectibranchiate stem-forms of the Pulmonata were shore-dwellers, which, in consequence of the ebb and flow of the tide, took to an amphibious mode of life, and converted the gill-cavity into a lung. They were thus, though still retaining their shell, *Oncidium*-like, and further differentiation followed, according as they remained on the sea-coast, wandered into fresh water, or became purely terrestrial animals.

At the same time Dr. Plate allows that the Oncidiidæ have so many points of resemblance to the Opisthobranchiata that the similarity cannot be supposed to be due to chance convergence, but must be regarded as the consequence of a common phyletic origin. These points of resemblance justify us in considering the Oncidiidæ as archaic forms which stand closer to the Opisthobranchiate stem-form of the Pulmonata than any group of Pulmonates now known. Thus, the Oncidiidæ are opisthopneumonous, the liver is tripartite, there are only three ganglia in the visceral chain, and the penis is armed with teeth, as it often is among Opisthobranchs.

Although, then, the Oncidiidæ exhibit the structural characters of the tectibranchiate primitive form of the Pulmonata more truly than any other division, it is equally true that in several points they have undergone secondary modification. In the first place they have lost the shell and the columellar muscle, as well as the olfactory organ and the jaw; the kidney projects so far into the lung-chamber that it becomes partly fused with the base thereof; the anus lies outside the lung-chamber; the aorta does not divide until some distance from its root, and the posterior aorta breaks up into two chief branches, a visceral and a genito-pulmonary artery; the back has developed special eyes, and in some cases arborescent appendages.

The author sums up his results in the following table:—

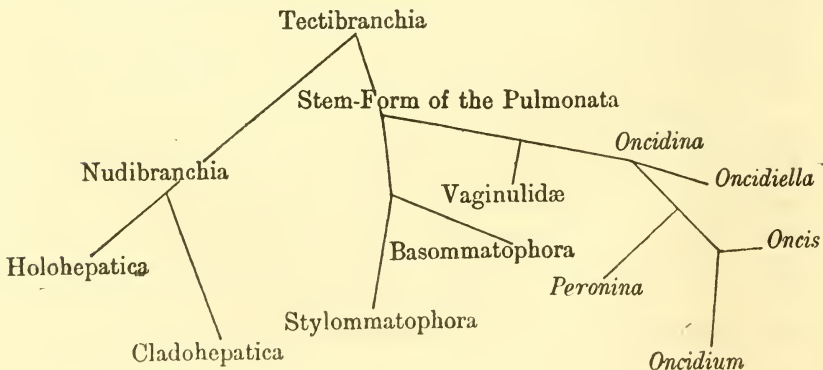

The memoir commences with a series of chapters on the anatomy of the various organs, and is followed by a systematic review, in which the following genera are recognized:—*Oncidium* (emend.), *Oncis* g. n., *Oncidiella*, *Peronina* g. n., and *Oncidina*; a systematic table gives the chief points of difference between them, and descriptive accounts follow of the thirty-two constituent species.

**Embryology of Chiton.\***—Mr. M. M. Metcalf gives an account of the development of *Chiton*, as studied in two species collected at Jamaica. In the segmentation most of the divisions are of the radial type, but in some cases the cells, instead of dividing meridionally and subsequently shifting, divide in the first case obliquely and reach their definite position without any subsequent shifting. This the author regards as a cenogenetic modification of the radial type of segmentation; it is due either to the simplification of development by acceleration or to crowding.

The blastopore is formed at the vegetative pole, and is at first quadrangular with a club-shaped furrow extending from its anterior edge forward along the mid-ventral line to the velum; this furrow disappears. The blastopore sends out an anterior slit-like process, the posterior portion closes, and the anterior part moves still further forward to lie just behind the velum. The mouth forms by the direct re-opening of the blastopore.

The phenomena of gastrulation in *Chiton* suggest comparison with *Peripatus*; but to the interesting question whether the resemblances are fundamental or secondary it does not seem possible to give a definite answer.

**Index to the Zoologischer Anzeiger.†**—Prof. J. V. Carus has had prepared an index to volumes xi.–xv. of his valuable journal; it is very full and has but few errors. With the preceding index to the first ten volumes, and Dr. Taschenberg's continuation of the 'Bibliotheca Zoologica' the zoologist, if not fully "up to date" with his literature, is now admirably supplied up to the end of 1892.

##### 5. Lamellibranchiata.

**Muscle-Fibres of Mollusca.‡**—Herr Ph. Knoll describes those muscle-fibres in various Lamellibranchs which exhibit double oblique striation, and agrees with Engelmann that the appearance is referable to a contraction-process, and that the more strongly refractive particles are disposed in two distinct spiral systems, not in one, as Fol and Ballowitz have maintained. He leaves it doubtful whether these particles retain their spiral arrangement in completely relaxed fibres. The striæ are not due to homogeneous fibrils, but to rows of "Disdiaklast" groups of great mobility arranged in a fibril-like manner. The fibres are regarded as transitional towards the cross-striped type. In *Eledone*, Knoll has found transitions between fibres with a marked double oblique striation and those with longitudinal striation, i. e. with striæ almost parallel to the longitudinal axis. Perhaps they are only contraction states of one type.

\* Stud. Biol. Lab. John Hopkins Univ., v. (1893) pp. 249–67 (2 pls.).

† Register zum Zoologischen Anzeiger, Jahrgang xi.–xv., 8vo, Leipzig, 1893, 329 pp. (double cols.). ‡ SB. K. Akad. Wiss. Wien, ci. (1892) pp. 498–514 (2 pls.).



## Molluscoida.

## a. Tunicata.

**Origin of Peribranchial Cavity in Ascidian Embryos.\***—Dr. O. Seeliger has investigated *Clavelina* and *Ciona*, and concludes that in the embryo of Ascidiæ the whole wall of the peribranchial cavity is formed from ectoderm. In the development of buds, however, the cavity is formed from two endodermic diverticula. The dilemma is immediately suggested, Are the two cavities not homologous, or is an organ of ectodermic origin homologous with one derived from endoderm? Dr. Seeliger accepts the second position, and suggests that when budding began in the phylogeny of Ascidiæ the ectoderm was too highly differentiated to be available for the formation of a peribranchial cavity. So also in regard to the nervous system of the bud, which the author (with Kowalevsky and Hjort) believes to be of endodermic origin. In fact there is little parallelism between the development of the ovum and the development of the bud.

According to the author, the exhalent aperture and cloaca did not arise from a special median invagination into which the two lateral peribranchial sacs secondarily open; they owed their origin to a dorsal expansion of the two peribranchial vesicles, which resulted in a union of the two apertures and the adjacent proximal portion. Finally, with special reference to *Ciona intestinalis*, Seeliger discusses the two different modes in which the branchial slits arise in ontogeny—two different modes which he endeavours to interpret as modifications of one.

**Formation of Mantle.†**—Dr. O. Seeliger has investigated this in *Salpa democratica*, *Clavelina lepadiformis*, and *Oikopleura cophocerca*, and confirms the conclusion recently stated by Kowalevsky and others that the mantle is in great part due to mesenchyme cells which migrate through the ectodermic epithelium. The latter has also a share in the formation, giving off secretory processes and also contributing cells. Indeed, if only the beginning of the formation be studied, it might be thought that the whole was due to ectoderm cells. The process is no cuticle-formation, for into the secreted substance cells and parts of cells pass and undergo modifications.

**British Tunicata.‡**—Prof. W. A. Herdman, returning to this branch of his studies after thirteen years, commences by remarking that with the fuller knowledge he now has of variations in the Tunicata, and after these years' experience, he is inclined to think that he formerly laid too much stress upon minute structural characters, and described as new species several forms which it would be better to regard as varieties. A list of the Ascidiæ in O. F. Müller's 'Zoologia Danica' is given, with the names that are now usually applied to the same forms; this is followed by a similar list of the species enumerated by Edward Forbes in Forbes and Hanley's 'British Mollusca,' and by a consideration of the species of Alder and Hancock. With regard to the variability in the number of tentacles, the published records show differences extending

\* Zeitschr. f. wiss. Zool., lvi. (1893) pp. 365-401 (2 pls.).

† Tom. cit., pp. 488-505 (1 pl.).

‡ Journ. Linn. Soc., xxiv. (1893) pp. 431-53 (4 pls.).



from sixteen to a hundred; this extraordinary range leads to the suspicion (raised by a late experience) that "I and others in the past may have been deceived by a few of the tentacles being very conspicuous, when in reality many others may have been present in addition."

A detailed account is given of the British members of the family Cynthiidae.

**Ascidians of Minorca.\***—Herr H. Heiden found a considerable number of new species in a collection from off this island. *Diazona hyalina* sp. n. is described from a single colony, which showed nowhere any signs of having been fixed. Of *Cystodites* there are three new species—*C. inflatus*, *C. polyorchis*, and *C. irregularis*. *Distomus tridentatus* sp. n. is of a bluish-green colour; *Distaplia intermedia* sp. n. is allied to *D. magnilarva* and *D. lubrica*. Of *Amarœcium*, *A. Blochmanni*, *A. Willi*, *A. fimbriatum*, *A. robustum*, and *A. Rodriguezi* are new; the last is named after Herr Rodriguez, and not the island of that name. *Leptochirum infundibulum* and *L. verrucosum* are also new.

**New Doliolum.†**—Dr. A. Borgert describes *Doliolum nationale* sp. n. from the Atlantic. It is nearly allied to *D. denticulatum*. The branchial apparatus is fastened dorsally beside the second muscle-hoop, and ventrally between the fourth and fifth hoops; the endostyle lies between the second and fourth; the intestine is bent and ends behind the sixth hoop on the right side; the ovary lies in the sixth intermuscular space; the testis lies parallel to the longitudinal axis, and has an elongated club-shape.

#### Arthropoda.

**Arthropoda.‡**—Prof. E. Perrier, in the third part of his 'Traité de Zoologie,' treats of the embryonic, or as they are wrongly called larval, forms of Crustacea methodically, by taking as the initial term the cases where freedom from the egg commences with the Nauplius-stage, where the body is only formed by the successive addition of segments in front of the telson. The free embryonic forms actually known are derived from these normal or primitive types, thus:—(i.) Extension takes place at a more or less advanced period in development; (ii.) instead of the ordinary formation of segments in front of the telson, a second is added behind the cephalothorax, and sometimes there is a third between the primitive head and the true thorax; (iii.) abdominal segments are formed faster and even sooner than the thoracic segments; (iv.) thoracic segments get in advance of the abdominal segments.

Secondary modifications result from the time of appearance of the cephalic segments, the more or less rapid changes undergone by the appendages, and so on. These considerations apply as well to embryos which are developed within the envelopes of the egg as to free embryos, and may be extended to all classes of Arthropods.

With regard to Insects, a methodical grouping of the facts known as to the development of vesicating Coleoptera suffices to show that the metamorphoses of *Sitaris humeralis* are only the end of a series of phenomena of hibernating and larval adaptations, and that they are not

\* Zool. Jahrb. (Syst. Abth.), vii. (1893) pp. 341-64 (1 pl.).

† Zeitschr. f. wiss. Zool., lvi. (1893) pp. 402-8 (1 fig.).

‡ Comptes Rendus, cxvii. (1893) pp. 652-4.

sufficiently exceptional to justify the creation of the new name hyper-metamorphoses.

The classification of the Coleoptera has been primarily based on the form of the jaws, by which these animals may be divided into two series, according as they are adapted for animal or vegetable aliment. In the first series the agile larvæ known as campodæiform predominate, and the tarsi of the adult are nearly always pentamerous. In the second series the larvæ are inactive or melolonthoid, and the tarsi may be tetra-, penta-, or hetero-merous. In each series the families have been arranged according to the degrees of condensation of the abdomen and the coalescence of the nervous ganglia.

**Morphology of Crustacean and Insect Appendages.\***—Dr. H. J. Hansen publishes a preliminary account of his prolonged studies on the homologies of Arthropod appendages. Among his chief conclusions are the following:—The occurrence of three joints in the basal piece of Crustaceans is the primitive state, still frequently persistent. The Malacostraca must be re-arranged, and the basis for this is to be found in part in the diverse structure of the thoracic limbs. In Thysanura and some Orthoptera there are four pairs of mouth-parts, homologous with those of Amphipods. There is a much closer agreement between the head of *Machilis* and that of Malacostraca than has been hitherto supposed. Hansen's particular results, which differ in many respects from current opinions, are summed up in fifty-one conclusions, of which the above afford only a general indication.

a. Insecta.

**Mimicry.†**—Dr. C. Haase continues his elaborate discussion of mimicry in Lepidoptera and in Papilionidæ in particular. The mimetic resemblances between Lepidoptera and other Lepidoptera, harmless beetles, stinging Hymenoptera, &c., are discussed, as well as mimicry in Diptera, Molluses, Batrachians, Reptiles, Birds, and Mammals.

The most general conclusion which the author draws is that the systematic relations of the Papilionidæ confirm the theory of the origin of mimicry in the course of natural selection.

**Muscular Action in Bombyx.‡**—Dr. M. L. Patrizi has made a number of experiments on the contraction of muscles in the silkworm and silkmoth. They are rather physiological than zoological. The duration of the contractions, the temperature changes, the velocity of the muscle-wave, the condition of tetanus, the duration of a reflex movement, &c., are discussed. As to the movements of the wings, Dr. Patrizi notes that just-hatched females showed 21·8 revolutions per second, and similar males 27·4 revolutions, with a maximum and minimum of 40 and 21·2. After interrupted copulation the number in the male was 30·4 (max. 45·2, min. 21·7); after naturally completed copulation the number was 25 (max. 34·7, min. 14·1).

**Spermatozoa of Dytiscus.§**—Prof. L. Auerbach has some remarks on a note which Ballowitz recently published in regard to his (Auer-

\* Zool. Anzeig., xvi. (1893) pp. 193-8, 201-12.

† Bibliotheca Zoologica (Leuckart and Chun), Heft 8, pp. 73-120 (14 pls.).

‡ Atti R. Accad. Sci. Torino, xxviii. (1892-3) pp. 452-69 (16 tracings).

§ Anat. Anzeig., viii. (1893) pp. 627-30.

bach's) researches on the spermatozoa of *Dytiscus marginalis*. It is the old tiresome question of priority. More interesting is the reference to Selenka's description of double spermatozoa in *Didelphys*, which seems rather the results of incomplete separation than of conjugation of spermatozoa.

**Copulatory Organs of Male Hymenoptera.\***—Herr C. Verhoeff asks whether the Hymenoptera possess the homologues of the "laminae basales" of male Coleoptera. These latter are parts which the author regards as of great phylogenetic significance. He concludes that though the parameres of the Coleoptera and Hymenoptera are homologous there are no homologous basal plates in the latter.

They have, however, an organ which is physiologically very like the basal plates, and he proposes to call it the lamina annularis or circular piece; he regards it as of great value in determining natural affinities. The organ in question was discovered by Hoffer and Schmiedeknecht, both of whom gave it the inappropriate names of *cardo* or capsule.

**Male Genital Apparatus of Hymenoptera.†**—M. Bordas, who has examined these organs in *Apis mellifica*, finds reason to differ from many of the results of his chief predecessors. He gives, however, only an account of his own observations, which appear to be limited to points of detail. There are some notes also on the same parts in *Vespa rufa*; other species have also been studied, and there appear to be considerable differences among them.

**Copulatory Organs of Libellulidæ.‡**—Herr J. Ingenitzky gives an account of the male generative apparatus of *Æschna grandis* and *Æ. cyanea*. It consists of six pairs of unjointed chitinous plates, attached to the second abdominal segment and very probably serving as an apparatus for seizing the female copulatory organs, and of a three-jointed penis which arises from a bulb which is attached to the third ventral segment.

This bulb contains a seminal reservoir in which the tubes of spermatozoa lie before copulation; the reservoir is completely separated from the cœlom, and passes into the canal of the penis; the walls of it and of the canal consist of a layer of small cubical cells, which secrete a thin chitinous cuticle. The cavity of the reservoir varies considerably in size at different times, being, when empty, compressed by the elastic sacs which surround it on either side. The walls of these sacs consist of a high epithelial layer, which passes directly into the hypodermis of the bulb; in the interior of the sac there are branched chitinous filaments which are connected with the chitinous wall of the bulb. The sacs are closed invaginations of the hypodermis, into which neither nerves nor tracheæ enter; their function appears to be to cover and protect the seminal reservoir. The musculature of the bulb, notwithstanding the statements of Rathke and Burmeister, is very feebly developed.

The bulb is richly supplied with tracheæ, which are wanting, however, within the seminal reservoir; they are accompanied by nerves from the third ventral ganglion.

\* Zool. Anzeig., xvi. (1893) pp. 407-12 (6 figs.).

† Comptes Rendus, cxvii. (1893) pp. 746-8.

‡ Zool. Anzeig., xvi. (1893) pp. 405-7 (2 figs.).



**Mouth-parts of Trichoptera.\***—Mr. R. Lucas has studied the mouth-parts of *Anabolia furcata*. Those of the larva, which he regards as secondary acquisitions, are first described. The quadrangular upper lip, the strong mandibles, the first pair of maxillæ fused as regards their cardines, and the second pair of maxillæ completely fused, are described in detail. In the head of the larva there are two pairs of salivary glands, the first smaller pair belonging to the mandibular segment, the second large pair belonging to the first maxillary segment. The second pair of maxillæ are associated with a third pair of glands—the spinning glands—of the mechanism and functions of which a careful account is given. In connection with the sensory organs of the larva, Lucas describes various forms of sensory hairs on the mouth-parts, and notes two clefts beside the opening of the spinning glands on the labium. They are openings of two innervated tubes, at the base of each of which lies a sensory cell. There are also several somewhat similar openings on the ventral surface of the labrum.

The author then describes the mouth-parts of the nymph; analyses those of the adult, and has notes on the salivary glands and sensory organs of the adult. He finds direct evidence that the adults eat; fine food-particles occurred from haustellum to œsophagus. It seems likely that the insect first moistens its food with salivary secretion, licks it with the haustellum, and passes it down by help of the fine teased-out hairs associated with the mouth. The mandibles have quite disappeared from the adult; the most important organ is the haustellum—the characteristic Trichopteron modification of the labium. In regard to the development of the parts, two general conclusions are drawn:—(1) The modification of the mouth-parts takes place through the formation of imaginal discs which gradually grow to the final form; (2) the first and second pair of salivary glands entirely disappear, and it is from the third pair (the spinning-glands of the larva) that the single pair of salivary glands in the imagines has its origin.

**Stigmata of Larva of Melolontha.†**—Dr. J. E. V. Boas reports that on each side of the larva of *Melolontha vulgaris* there are nine short and wide tracheal trunks, each of which is shut off from the exterior by a brown plate; this consists of a reniform sieve-plate, and a curved bulla which fits into the cavity of the plate. As a fact the trunk is provided with a large external opening, which corresponds to the ordinary stigmatic orifice of insects, but it is under ordinary circumstances closed by the plate and bulla, and is only open during ecdysis; at first it is circular, but later it becomes a cleft.

A transverse section shows that the bulla is a simple tegumentary fold, the outer chitinous layer of which has become particularly firm. The plate forms a horizontal half-roof, which springs from one side of the tracheal orifice; it is supported by obliquely set bars which spring from the adjoining part of the inner side of the tracheæ. The plate and bars are purely cuticular structures. Further details are reserved for a fully illustrated memoir.

\* Arch. f. Naturg., lix. (1893) pp. 285-330 (3 pls.).

† Zool. Anzeig., xvi. (1893) pp. 389-91 (3 figs.).



**Respiratory Movements of Coleoptera.\***—Sig. L. Camerano does not agree with Plateau's conclusion, that the special expiratory muscles are wholly abdominal, for in *Melolontha vulgaris*, *Hydrophilus piceus*, *Carabus italicus*, and *Dytiscus marginalis*, he finds that the metathorax has proper respiratory movements, produced by special expiratory muscles, which contract at the same time as those of the abdomen.

**Orthoptera of Galapagos.†**—Mr. S. H. Scudder remarks on the extreme poverty of the Orthopterous fauna under the equator; only fifteen species appear to be endemic in the Galapagos, and all these are distinctly allied to fauna from South and Central America. Five are apterous or subapterous, and a sixth has an apterous female. Mr. Scudder thinks that the explanation of these facts is to be found in supposing that the islands are of a very recent origin, and have obtained their present Orthopterous fauna by the chance advent of pregnant females as waifs from the nearest shore; a wingless form would stand the best chance, as it would have less inclination to leave the drift-wood or whatever kept it above the water. Some have, of course, reached the islands by flight.

#### 5. Arachnida.

**Endosternite of Arachnida.‡**—Herr W. Schimkewitsch finds that this structure is composed of two parts:—(1) of a transversal muscle corresponding to the adductor muscle in Crustacea, and (2) of a pair or perhaps several pairs of mesodermic tendons connected with the transverse muscle-strands.

**Stigmata of Arachnida.§**—Mr. H. M. Bernard comes to the conclusion that the tracheal invaginations of the ancestor of the Arachnids were strictly segmental, and that they were of some simple tubular form, from which the laminate form could be easily developed. Every segment appears also to have borne a pair of legs, so that the ancestral form had a considerable resemblance to those of the Myriopoda and Hexapoda, though differing from them in having the rows of stigmata ventral instead of lateral, together with specialized oral appendages.

Later modifications of the primitive Arachnid were the differentiation of the body into cephalothorax and abdomen, and the loss of the abdominal limbs, vestiges of which persist as genital opercula, pectines and spinning mamillæ. The absence of traces of stigmata from the second and third segments may be due to the fact that, in the formation of the mouth-parts, the first three segments early fused together.

Mr. Bernard is of opinion that his investigations on the comparative morphology of the Galeodidæ go far to establish the classification which ranks the Arachnids as an independent group of the tracheate Arthropoda, "as distinguished from that which would deduce them from the specialized Crustacean *Limulus* through the specialized Arachnid *Scorpio*."

**Instincts of Common English Spiders.||**—Mr. R. I. Pocock has some interesting notes and observations on some common English spiders.

\* Atti R. Accad. Sci. Torino, xxviii. (1892-3) pp. 500-5.

† Bull. Mus. Comp. Zool., xxv. (1893) pp. 1-25 (3 pls.).

‡ Zool. Anzeig., xvi. (1893) pp. 300-8 (3 figs.).

§ Nature, xlix. (1893) pp. 68 and 9 (1 fig.).      || Tom. cit., pp. 60-3.

*Agalena labyrinthica* has a special liking for furze bushes; and it seems reasonable to suppose that so prickly a site for the snare saves the young and nest from destruction by the noses and legs of cattle. He thinks that spiders avoid contact with bees for fear of being stung; that *Eristalis* is mistaken for a bee, and that the bite of the spider causes the death of an insect by the injection of poison. The process of pairing is carried on with remarkable pertinacity, and during it, both male and female seem utterly oblivious to all their surroundings.

Though Mr. Pocock could never be sure of attracting *Agalena* to a vibrating tuning-fork *Amaurobius similis* would always come, and even climb along the instrument, but it does not seem to be able to discover whence the sound proceeds, unless its web is actually touched with the tuning-fork.

On the other hand, *Pholcus phalangioides* does not learn of the proximity of the fork by the vibration of its web. Small specimens of *Epeira diademata* behave differently from full-grown examples, and it appears that there is a runaway instinct which comes into play so long as the spider is too small to cope with a wasp.

**Chernetidæ.\***—Mr. H. M. Bernard, in his notes on this family, makes special reference to the vestigial stigmata, and to a new form of trachea. The signs of the stigmata may easily be overlooked as they can only be seen on cleanly macerated specimens with a high (300–500) magnifying power. The “ram’s-horn” organs, described by Menge and by Croneberg, may be found to present features hitherto unnoticed. They are large chitinous organs, capable of considerable extension; they open laterally under the genital operculum, which protects their orifices; they were found to be beset with air-chambers, wherever there was room for their development.

By the older authors these organs were thought to be reproductive, and their presence in males only, and their relation to the genital apertures, are *inter alia*, arguments in support of this view. On the other hand, not only have they a resemblance to tracheæ, but their very position may be said to be in close relation with rudimentary limbs—which is typical of tracheæ; moreover, the air-chambers render the respiratory function of the invagination almost unquestionable. Mr. Bernard thinks that we have here to do with one of the simplest of all known tracheal invaginations—a short blind chitinous tube, without highly specialized crenulations, and without specialized apparatus for the protection of the orifice; and he suggests that the ram’s-horn invaginations opening under the genital operculum, in the Chernetidæ, may be the nearest approach to the primitive form of tracheæ yet discovered.

**Activity of Heart of Spiders.†**—M. W. Wagner has studied the physiology of the heart in *Sparassus virescens*. In its normal state there are three periods—the systole, diastole, and the period of repose, which are all of the same duration. When the activity becomes exaggerated there is no period of repose. The pulse is higher with higher, and lower with lower temperatures; in a period of hunger the pulsations become very rapid but extremely feeble.

\* Journ. Linn. Soc., xxiv. (1893) pp. 410–30 (2 pls.).

† Ann. Sci. Nat., xv. (1893) pp. 311–24 (1 pl.).

**Anatomy of *Bdella arenaria*.**\*—Dr. L. Karpelles gives a detailed account of the anatomy of this Mite, which has a body from 0·6-0·7 mm. long, 0·2-0·3 mm. broad. The endoskeleton is more strongly developed than in any Mite known by the author. The stigmata of the trachea lie at the base of the mandibles. There are three pairs of dilator muscles to the œsophagus. The central venous system is of considerable length; tactile setæ are not well developed. An organ surrounding the mouth is compared with the pre-ventricular gland of the Oribatidæ lately described by Mr. Michael, but the author was unable to find its efferent duct. The concretions in the excretory organ appear to consist of oxalate of calcium or salts of uric acid. The female organs consist of an ovary, two oviducts, the uterus, vagina, and an accessory gland.

#### ε. Crustacea.

**Myology of *Palinurus Edwardsi*.**†—Prof. T. Jeffery Parker and Miss Josephine G. Rich find, contrary to the teaching of all the text-books, that the great ventral mass of muscle in the abdomen is not exclusively a flexor, but gives rise to slips which, being inserted into the terga and pulling in an almost horizontal direction, must act as extensors. The ventral muscles are far more complex than is ordinarily supposed, and the authors have had to make several new terms. The muscle called levator abdominis is found to rotate the abdomen on the cephalothorax. Several bands pass between the telson and the lateral tail-lobes, and so serve to approximate the parts of the fin during extension of the abdomen. The mandible is acted on by three adductors and two abductors.

**Germinal Area of *Mysis*.**‡—Prof. R. S. Bergh has set himself the task of determining the structural relations between the germinal areas of Annelids and Arthropods, and has begun with *Mysis*. His investigations begin at the stage when the blastoderm has spread over the yolk, forming a simple layer of large, flat cells, and when there are as yet no nuclei or yolk-cells. At a definite zone the blastoderm soon thickens, forming a transverse band, lying in a shallow depression. This germinal disc is at first single-layered, but by proliferation in its median region a deeper inner layer is rapidly formed. In the superficial layer an arch of sixteen large cells becomes clearly defined—the “*Urzellen*” of the ectodermic part of the germinal area; and the deeper inner cells are differentiated into (1) yolk (vitellophagous) cells which migrate into the yolk, (2) a compact endoderm-plate from which the epithelium of the mid-gut and liver arises, and (3) eight myoblasts or “*Urzellen*” of the mesoderm.

Subsequently the ectoderm becomes differentiated into what may be called a naupliar and a metanaupliar rudiment. The first consists of polygonal cells which show no regular arrangement in longitudinal and transverse rows, and are derived from ordinary blastoderm cells; the latter consists of regular longitudinal and transverse rows of cells which arise from the “*Urzellen*” proper. From the first rudiment arises the

\* Abh. Zool. Bot. Ges. Wien, xliii. (1893) pp. 421-30 (2 pls.).

† Macleay Memorial Volume, Sydney, 1893, pp. 159-78 (5 pls.).

‡ Zool. Jahrb. (Abth. Anat.), vi. (1893) pp. 491-528 (4 pls.).



whole region of the eyes and the nauplius appendages; from the second arises the region of the body behind the mandibles.

The author gives interesting details in regard to the remarkably strict regularity in the cell-divisions of the ectodermic germinal area. The "Urzellen" always divide so that the equatorial plane is at right angles to the longitudinal axis of the embryo, and their descendants keep up this regularity for a long time, always dividing equally, and spreading in regular rows from the median ventral line sidwards.

As to the ventral nerve-cord, Bergh shows that the ectodermic cells in that region arise as "Urzellen," which by repeated division (budding) form cell-rows, spreading inwards.

When the development of *Mysis* is compared with that of Annelids (Oligochæta and Hirudinea), the first point of resemblance consists in the manner of growth—the budding of "Urzellen" and the serial arrangement of the resulting cells. But in the Oligochæta and Hirudinea the ectoderm cell-rows of the germinal area are generally covered by the epidermis, whereas in *Mysis* they lie quite freely, and even give origin to the epidermis of the related region. Moreover, in the Oligochæta and in *Clepsine* the cell-rows are rudiments of quite definite organs, while in *Mysis* they form the material for all the ectodermic structures of the given region. Perhaps the Polychæta may be more thoroughly congruent. It may also be noted that the number of ectoderm "Urzellen" and of myoblasts in *Mysis* and other Crustacea is much greater than in Annelids. But more material must be collected before any thorough-going comparison can be made.

**Antennæ of Cyclopidæ.\***—Herr Al. Mrázek finds the origin of the antennæ of Cyclopidæ in the type possessed by Calanidæ. A change of life and associated changes in the function of the antennæ brought about the transition from a morphologically many-jointed, but physiologically unjointed, type to one in which the joints become functional. The difference between the physiological and the morphological segments can still be made out. The segments forming a physiological segment are more intimately connected than those which belong to two different (physiological) segments, and eventually they may fuse.

**The Genus Cyclops.†**—Herr O. Schmeil has begun a monograph of the fresh-water Copepods of Germany. At the outset he discusses the recent contributions, progressive and otherwise, which have been made to our knowledge of the systematic relations of these Crustaceans. In 1863 Claus recognized 14 German species, now 49 are known, and additions to the list must be looked for. After giving diagnoses of the three families Cyclopidæ, Harpacticidæ, and Calanidæ, the author gives a general description of the genus *Cyclops*, and the rest of his monograph, so far as the parts have reached us, consists of descriptions of 23 species of *Cyclops*.

**The Pontellidæ.‡**—Prof. C. Claus begins his discussion of this family with an account of the antennæ and their development; he then describes the nauplius larvæ and the cyclopid stages, and finally passes

\* Zool. Anzeig., xvi. (1893) pp. 376-85.

† Bibliotheca Zool. (Leuckart and Chun), Heft 11, pp. 1-184 (8 pls.).

‡ Arbeit. Zool. Inst. Univ. Wien (Claus), x. (1893) pp. 233-82 (5 pls.).



to a consideration of the nomenclature and systematic relations. The characters of the family are stated in the following diagnoses:—The body-form is usually compressed, often large, with much reduced, and in the female markedly shortened abdomen; the head is separate from the thorax, and there is a transverse delimitation of the anterior part of the head; the fourth and fifth thoracic segments are usually fused; the abdomen of the male has five segments, with a short terminal segment and elongated symmetrical furcal branches; the abdomen of the female has from 3–1 joints, is usually unsymmetrical, often bears conical or spine-like outgrowths, with expanded furcal branches and thickly feathered, often fan-like furcal setæ. The tripartite median eye protrudes spherically beneath the rostrum, and there are two dorsal eyes usually with corneal lenses. The anterior antennæ have 24 or 25 joints, often reduced by fusion of certain joints of the basal half. The right antenna of the male is prehensile, usually with a much swollen median region of 13–16 or 17 joints, and with four smooth or toothed setal ridges on the geniculate joints. The accessory branch of the posterior antenna is reduced, with no intermediate joint, and with short terminal joints. The mandibles have a strong toothed blade and two-branched palps. The maxillæ have a rudimentary third basal piece, elongated inconspicuous epipodial pieces, and short reduced inner and outer branches. The anterior maxillipede is very well developed, with strong spinose hooked setæ. The basal piece of the posterior maxillipede is strongly developed, with three finger-like lobes on the inner margin, each bearing spinose setæ; the simple intermediate joint is much reduced; the terminal piece has 3–5 joints. The inner branch of the four swimming feet is short, slight, and two-jointed, that of the first pair is three-jointed. The fifth pair of feet in the female are symmetrical, with quite rudimentary inner branches; in the male, that on the right has a prehensile chela, that on the left has a hooked terminal joint. A revision of species is given.

**New Observations on Cyclops.\***—Prof. C. Claus describes five stages in the development of *Cyclops*, the characters of the integument and of the furcal setæ, the receptaculum seminis and its glandular apparatus for forming egg-sacs, the minute structure and the development of the antennæ and of the male's prehensile antennæ in particular.

**Skeleton of Copepoda.†**—Prof. C. Claus discusses the so-called "abdominal vertebra" (*Bauchwirbel*) on the integumentary skeleton of Copepods and the associated median plates between the natatory appendages. He refers especially to the researches of Zenker and of Hartog, expands his own previous description of the complex structures in question, and compares their relations in the different families of Copepods.

**Ovum of Branchipus.‡**—Dr. A. Brauer has followed the ovum of *Branchipus Grubii* v. Dyb. from its origin until the time of laying. The most important result of his work is his corroboration, in almost all important points, of the results reached by Van Beneden and Boveri in regard to *Ascaris*. We shall restrict ourselves to giving Brauer's

\* Arbeit. Zool. Inst. Univ. Wien (Claus), x. (1893) pp. 283–356 (7 pls.).

† Tom. cit., pp. 217–32 (3 pls.).

‡ Abh. K. Preuss. Akad. d. Wiss., 1892, p. 66 (3 pls.).

observations on the reducing divisions. In the germinal vesicle six chromatin loops arise by transverse division, and another division raises their number to twelve. Then follows a double longitudinal cleavage, with the result that twelve tetrapartite chromosomes form the equatorial plate of the first directive spindle. In the male and female pronuclei 6 chromatin loops arise by transverse division, another division raises their number to 12, a single longitudinal division follows, and thus 24 bipartite chromosomes form the equatorial plate of the first segmentation spindle. In the segmentation nuclei, it is likely that 6 loops arise by transverse division, and two subsequent divisions increase the number to 12 and then to 24. A longitudinal cleavage follows. The result is that there are 24 bipartite chromosomes in the equatorial plate of the spindle.

**The Genus *Apus*.**\*—Dr. F. Braem describes a new species of *Apus* from Syria, and has made the study of this form an occasion for revising the other species of the genus. He begins with Brauer's *Lepidurus Grubei* and shows that an exaggerated appreciation of minutiae has complicated the taxonomy beyond endurance. We need not go into details; the point is that the systematists seem to have forgotten that distinct species must be established on account of differences greater than those which may occur between the members of a family. Of *Apus productus* the author recognizes two varieties, var. *Schäfferi* (Regensburg, Wien, Berlin, Breslau, Königsberg, &c.), and (?) var. *glacialis* Kröyer (Greenland). Distinct from these are the varieties *Sieboldii* (Rouen) *Lubbocki* (Sicily), *Dayi* (Syria), *Middendorffii* (Kiew), which are united by Braem in *Apus extensus* n. sp. He also deals with *Apus caneriformis*, *A. numidicus*, and *A. sudanicus*.

## Vermes.

### a. Annelida.

**Researches on Syllideæ.**†—Dr. A. Malaquin has a monograph on these Worms, which he arranges in four groups —1, Exogones, e.g. *Exogone*; 2, Euxyllides, e.g. *Syllides*; 3, Syllides, e.g. *Syllis*, and 4, Autolytes, e.g. *Autolytus*. The cuticle, which is generally delicate, is thick in the Syllides; various forms of glandular cells are to be found in the epidermis; the muscles of the body-wall are always arranged in very simple bundles, as in the Archannelida, and are never pennate.

The brain has no limiting membrane, and there is no sharp demarcation between the nervous and epidermal elements; the medullary substance contains several masses or centres, and the œsophageal connectives are always superficial or lie in the epidermis. The ventral medulla is formed of one median and two lateral cords, and is nearly always in contact, by its ventral surface, with the epidermis; in *Syllis* it is, indeed, removed from it, but is still connected by a pedicel. There are typically two pairs of eyes, the development of which shows that the different layers which compose the eye arise from the differentiation of a single layer of cells. Whatever be their degree of development, and there is in this considerable variation, the eyes are always formed of

\* Zeitschr. f. wiss. Zool., lvi. (1893) pp. 165-87 (1 pl.).

† Lille, 1893, 8vo, 477 pp., 14 pls. From Mem. Soc. Sci. Lille.

rods, which secrete by their distal extremity a refractive or crystalline body; the anterior refractive portions of the rods form the vitreous body, the median pigmented parts the retina, and the thread-like ends put the rods into relation with the nerve-cells of the ganglionic layer. A similarly simple eye has been described by Fraisse in the molluscan *Fissurella græca*.

The cervical organ may be in the form of ciliated pits, ciliated fins, ciliated or non-ciliated epaulettes; they always consist of much elongated epithelial cells encrusted at their base with direct prolongations of the brain or with large nerves which are given off from its hinder portion.

A synonymical table is given of the very various names that have been applied to the different portions of the pharynx, which is in all cases lined by a thick layer of chitin. The proventriculus is essentially formed of radial columns of muscular substance disposed around the axis of the organ; each row is separated from the next by a transverse fibrillar diaphragm. Considerable differences are exhibited in the construction of these columns.

The vascular system is very simple, and has no superficial ramifications, though respiration is purely cutaneous, except when it is effected by the digestive tube. The nephridia do not play an important part in excretion, but at the period of reproduction they increase considerably in size, and serve as efferent ducts for the genital products.

Reproduction is effected by schizogamy (misnamed alternation of generation) in which a sexual bud separates from a non-sexual stolon, and epigamy (so-called direct reproduction), in which the whole of the individual acquires secondary sexual characters at the time of maturity. The formation of stolons may be effected by gemmation or fission. Schizogamy and epigamy may exist independently of one another, but the distinction is not of generic value, while there are some forms in which both modes of reproduction are to be seen.

The different modes of growth of the body are fundamentally forms of one phenomenon—the production of zoonites; the tissues contained in a formative zoonite are not differentiated, but at the same time one may recognize in them the three primary layers. The differentiation of tissues may be followed in proceeding from behind forwards. At sexual maturity the reproductive elements lie freely in the general cavity and compress the intestine.

The segmentation of the ovum is epibolic, and the larva is achæitous. The larva may have a musculo-glandular pharynx (“larve monopharyngienne”) which may be free, or it may also have a proventriculus (“larve dipharyngienne”); the latter type is peculiar to the Syllideæ. The larvæ leave the eggs at different times in different forms.

With regard to the appendages of the cephalic segment and their homology with the appendages of other segments, the author gives the following table:—

Anterior lateral antennæ	=	Ventral rami.
Median antennæ	=	Dorsal cirri.
Palpi	=	Ventral cirri.
Posterior lateral antennæ	=	Dorsal rami.

The author believes that the segments of the Annelid type are all morphologically similar, and that their constitution is determined by serial repetition and bilateral symmetry.



**Polydora.\***—M. F. Mesnil contributes an account of his study of some of the species of this Annelid. *P. cæca* appears to be the most primitive, while *P. ciliata* is much more differentiated; *Pygospis elegans* has a number of the characteristics of *Polydora*, and *Spio Meczniokowianus* has a close relation to the same type. *P. Giardi* sp. n. has been taken at Wimereux (Pas-de-Calais).

**New Irish Earthworms.†**—The Rev. H. Friend describes two new species of Earthworms found in Ireland, which he calls *Lumbricus papillosus* and *Allurus macrurus*. It is remarked that the habitat of an earthworm is related to the shape of its hinder end. It is only the species which expose a portion of their body when in search of food, while the other remains in the burrow, that have a distinctly flattened tail.

**Jaws of Hirudinea.‡**—Herr J. M. Croockewit finds that the number of unicellular glands in the head of *Aulastomum* are much less numerous than in *Hirudo*; their secretion contains a large number of small granules, which stain deeply with hæmatoxylin; by their means the glands and efferent ducts can be easily made out. The teeth, which are completely enclosed in the cuticle, may be isolated by caustic potash; or, for purposes of sections, they may be decalcified in picric acid and alcohol.

In sections it may be seen that the cuticle which invests the epithelium of the jaw, increases greatly in thickness on the anterior and hinder surface of the jaw, as soon as it reaches the free edge. Between the cuticle of the anterior and that of the hinder surface there is a cleft-like space; in this the efferent ducts open, but, wherever there is a tooth, the space is closed. The decalcified teeth stain well with hæmatoxylin, but the cuticle remains free from it; the tips of the teeth do not project beyond the free edge of the cuticle.

The teeth may be considered as the supporting apparatus of the cutting cuticle; as soon as the wound is made by the jaws it is impregnated with the secretion which pours out between the teeth, and the coagulation of the blood is thus prevented; for, as Hayercraft has shown, there is in the head of *Hirudo* a substance, which delays the coagulation of the blood. Further details are promised.

**Infundibular Apparatus of Hirudinea.§**—Prof. R. Leuckart corrects what he takes to be some errors in the descriptions given by preceding writers on the nephridia of Leeches. He finds that the masses of granular structures which Bourne regarded as degenerative are cells which, but for their size, closely resemble typical nephridial cells. The spaces amongst them, whether canalicular or lacunar, are all in direct connection with the canal system of the nephridia. The author gives a short sketch of the differences exhibited by various genera of Hirudinea.

**Eye of Clepsine.||**—Prof. C. O. Whitman criticizes severely some conclusions reached by B. L. Maier ¶ in regard to the eye of *Clepsine*. "A theory of the development is put forward without so much as a

\* Comptes Rendus, cxvii. (1893) pp. 643-5.

† Proc. R. Irish Acad., ii. (1893) pp. 453-62 (5 figs.),

‡ Zool. Anzeig., xvi. (1893) pp. 427-9.

§ Ber. Verhandl. Sächs. Ges. Wiss. Leipzig, 1893, 325-30.

|| Zool. Jahrb. (Abth. Anat.), vi. (1893) pp. 616-25 (5 figs.).

¶ Op. cit., v. p. 552.



single fact of development to support it; and this theory happens to be all wrong from beginning to end."

According to Whitman's previous studies,\* both the eyes and the segmental sense-organs develop as local thickenings of the epidermis. The ordinary metameric sensillæ are serially homologous with the eyes, and are connected with them by gradual steps of structural elaboration. They are double organs, both in structure and function, having an axial cluster of tactile cells and large, clear visual cells around and beneath these. So is it also with the eye. A double innervation of the eye in *Hirudo* and *Aulastomum* has been detected by Maier, but he has failed to notice its significance. This is plain when we take the eye of *Clepsine* as our starting-point. There the eye-nerve is composed of two parts—(1) optic fibres terminating in the visual cells, and (2) tactile fibres ending in the hair-cells. In the *Hirudo* eye it is likely that the tactile cells have been turned into visual cells, but the double nerve persists. The eye of a leech can form no image of external objects, but it has a "photesthetic" sensibility, shared by the metameric sensillæ when these have visual cells. The suggestiveness of a series beginning with pure tactile organs and ending with pure visual organs is again pointed out.

#### β. Nematelminthes.

**Spermatogenesis in *Ascaris megalocephala*.**†—Dr. A. Brauer finds in the spermatogonia of the *univalens* variety a simple splitting of the chromatin grains; these arrange themselves in a long thread, which separates into two segments—the final chromosomes. The result is two split or bipartite chromosomes. In the spermatocytes of the same variety there is a double splitting of the chromatin grains, and these arrange themselves on a thread which is not divided. The result is a doubly split or tetrapartite chromosome.

In the variety *bivalens* there is a simple splitting of the chromatin grains, and these form a thread which divides first into two, then into four. The result is four bipartite chromosomes. In the spermatocytes there is a double splitting of the chromatin grains, and these form a thread which divides into two segments. The result is two tetrapartite chromosomes.

The author has a long discussion of his results, which harmonize with those which he obtained from his study of *Branchipus*.

**Schneider's Pore and Œsophageal Glands in Nematodes.**‡—Prof. O. Hamann has lately found Schneider's pore and its canal in a large number of Adriatic *Ascaridæ*, *Strongylidæ*, and in *Lecanocephalus*. In the last-named the pore lies a short distance below the lips on the dorsal and inner wall of the Œsophagus, and forms a communication between the lumen of this tube and an organ which lies in the wall of the Œsophagus. The pore leads into a capillary membranous canal, which is surrounded by a granular substance, and may be traced to the neighbourhood of the sucking apparatus, which separates the Œsophagus from

\* Journ. Morphol., i. (1887); ii. (1889).

† Arch. f. Mikr. Anat., xlii. (1893) pp. 153-213 (3 pls.).

‡ Zool. Anzeig., xvi. (1893) pp. 432-4.

the mid-gut; at the end of this organ are stellate cells, which have probably an excretory function.

The organ which is described as a cæcum, and lies in the anterior region, is shown by transverse sections to be solid, and to be a continuation of the ventral side of the œsophageal wall. It appears to be a gland, made up of cells, and traversed by an intracellular canaliculus. It is divisible into two halves, and there are two canaliculi, one in each; these open into the wall of the œsophagus. The gland has, fundamentally, the same structure as the excretory organ of the lateral line.

In parasitic Nematodes there are other organs in the cœlom which are connected with the lateral lines. *Lecanocephalus* possesses several peculiar organs, 0·4 mm. in diameter, which are distinguished by their digitate ramifications, and have a disproportionately large nucleus in their centre. The branches carry small pyriform structures, which, by their granulated, highly refractive substance, lead to the supposition that they may be homologous with the ciliated organs; no cilia, however, have been detected. A fuller account is promised.

*Trichosomum strumosum* sp. n.\*—Herr J. Reibisch describes this new parasite, which he found in the œsophageal epithelium of *Phasianus colchicus*. It appears to be the cause of great mortality among young pheasants. The body is very slender; at the anterior end there is a vesicular dilatation of the cuticle; the anal end is obliquely truncate, and bears in the male two valves beside the cloaca; the female apertures lie laterally 5 mm. behind the beginning of the intestine; the male genital duct extends forwards to the pear-shaped cells. The male measures 17·4 mm. in length by 1 mm. in maximum breadth; the female, 37 mm. by 15 mm.

**History of *Filaria uncinata*.**†—Prof. O. Hamann has been able to find the intermediate host of *F. uncinata*, which is so frequently found in the digestive tract of Ducks and Geese, where masses several centimetres in size are often to be seen. These worms are sexually mature, and they give rise to embryos which either escape actively by the mouth, or, as is more ordinary, are carried away with the fæces. These last are greedily eaten by *Daphniæ*, which thus become infected by the parasite; the worm makes its way into the body-cavity, where it remains till the *Daphnia* is eaten by a Duck or Goose.

**Nematodes of Pharyngeal Glands of Ants.**‡—M. C. Janet describes a form of *Pelodera* which lives in the pharyngeal glands of *Formica rufa*, *Lasius flavus*, and other Ants, just as *Leptodora flexilis* lives in the salivary glands of *Limax cinereus*. To obtain a number of these Nematodes it is only necessary to tease out the head of an individual from a spot infected by these parasites. On examination they are found to be a larval stage of a species which in its free state lives in the débris of the ants' nests. This parasite does not appear to be found in the abdomen of ants.

\* Arch. f. Naturgesch., lix. (1893) pp. 331-40 (1 pl.).

† Centralbl. f. Bakteriol. u. Parasitenk., xiv. (1893) pp. 555-7.

‡ Comptes Rendus, cxvii. (1893) pp. 700-3 (1 fig.).

*Filaria immitis* in a Japanese Wolf.\*—Herr Janson reports the presence of a large number of examples of this parasite in the heart of a Japanese wolf. This is the first time that *F. immitis* has been found in any other animal than the dog, and the author believes it is common to all species of the genus *Canis*.

Trichinosis.†—Dr. P. Cerfontaine gives a more detailed account of his studies on Trichinosis, to the preliminary notice of which we have already called attention.‡

Acanthocephala.§—Dr. J. E. Kaiser continues his monograph on *Echinorhynchus*. The first part contained a description of nine species, including two new forms, *E. uncinatus* and *E. spinosus*, and an account of the structure and development of the cuticle, the hypodermic tissue, and the musculature. The second part deals with the structure and development of the nervous and reproductive systems, and with the embryonic and post-embryonic development. To this is added an appendix containing a critical review of Hamann's recent monograph on Acanthocephala.

#### γ. Platyhelminthes.

Spermatogenesis of Turbellaria.||—Herr W. Repiachoff describes the origin of the spermatozoa from the spermatids of an undescribed "transparent pelagic acelous" Turbellarian. His most important result is his corroboration of the view that the spermatozoa are distinctly cellular rather than nuclear. In various stages it is possible to distinguish an outer protoplasmic substance from an enclosed chromatin mass. The author believes that what often seems to be absence of protoplasm from the head of a ripe spermatozoon is only apparent.

*Distomum clavigerum*.¶—Dr. E. J. Noack has investigated the anatomy and histology of this Fluke, which is equally common in the green and brown frog. It is distinguished from most other members of its genus by the lateral position of the genital pores. It is also remarkable for the fact that the oral sucker is more powerfully developed than the ventral; in the latter there are no meridional fibres, and the equatorial fibres stand so far apart that they cannot be said to form a layer. Self-fertilization does not seem to occur.

Monograph of *Temnocephaleæ*\*\*—Prof. W. A. Haswell has prepared a monograph of this interesting group of parasites, which forms part of the handsome volume which has been prepared as a memorial to the late Sir W. Macleay. In making a revision of the species he has found it necessary to establish a new genus *Craspedella* (*C. Spenceri*) for a parasite which lives in the branchial cavities of *Astacopsis bicarinatus*. Of the genus *Temnocephala* twelve species have been recognized, which

\* Berl. Tierärztl. Wochenschr., 1892, No. 29. See Centralbl. f. Bakteriol. u. Parasitenk., xiv. (1893) p. 499.

† Arch. de Biol., xiii. (1893) pp. 125-45 (1 pl.).

‡ See this Journal, 1893, p. 634.

§ Bibliotheca Zoologica (Leuckart and Chun), Heft 7, pp. 1-148 (10 pls.).

|| Zeitschr. f. wiss. Zool., lvi. (1893) pp. 117-37 (1 pl.).

¶ 8vo, Leipzig, 1892, 56 pp., 2 pls. See Centralbl. f. Bakteriol. u. Parasitenk., xiv. (1893) pp. 565 and 6.

\*\* Macleay Memorial Volume, 4to, Sydney, 1893, pp. 93-152 (6 pls.).



are to be found in South America, Australia, New Zealand, the Philippines, Madagascar, and North-Eastern India. After dealing in separate chapters with the various organs and systems, the author proceeds to discuss the affinities of the family.

If we regard them as ectoparasitic Trematodes, then their integument is quite exceptional, for they have a complete distinct epithelial layer; in this respect, indeed, they approach the Rhabdocœle Turbellaria, and the presence of vibratile cilia in *T. minor* and *T. Dendyi* makes the resemblance very close. Other points of similarity are the presence of rhabdites in the integument and the characters of the intestine and its epithelium. The excretory system is quite peculiar, but more nearly resembles that of ectoparasitic Trematodes than that of Rhabdocœles.

The comparatively large brain, the rich development of nerves running forwards, the three pairs of posterior trunks, and the highly developed subcutaneous nerve-plexus give *Temnocephala* a high place among Platyhelminths; but, as has been shown by Lang, all these points are to be seen in *Tristomum molæ*. In the structure of the reproductive organs the resemblances to Rhabdocœles are more marked than those to ectoparasitic Trematodes; perhaps the resemblance is closest in the Vorticidæ. A remarkable point of resemblance is in the system of accessory glands secreting rounded granules connected with the male apparatus; von Graff's account of these structures as seen in Rhabdocœles applies equally well, word for word, to *Temnocephala*. In having a direct development it agrees equally well with the monogenetic Trematodes and the Rhabdocœla.

On the whole, Prof. Haswell is inclined to think that the Trematode affinities of this parasite somewhat predominate over the Turbellarian. The large ventral sucker, the excretory sacs, and the nervous system may be set down as decidedly Trematode and not Turbellarian in character. The preponderance, however, is only slight, and little fault can be found with a systematist who should regard the *Temnocephalæ* as aberrant Rhabdocœles specially modified in accordance with a peculiar mode of life.

**Apparently New Type of Platyhelminth.\***—Prof. W. A. Haswell has found in the burrowing crayfish of Gippsland, Victoria (*Eugæus fossor*), a remarkable new parasite which may be a Trematode. He proposes to call it *Actinodactylella Blanchardi*. The whole animal, which is very soft, measures about 1 mm. by 0·3 mm., and is pear-shaped in form. There is a pair of tentacles on the cephalic lobe, and behind these there radiate out from the lateral margins of the body five more pairs of tentacles of relatively considerable length when fully extended. The animal moves exactly after the manner of a leech. At first sight Prof. Haswell was inclined to regard his find as allied to *Temnocephala*.

Although, however, it is Trematode-like in general form, in the possession of anterior and posterior suckers, in the absence of vibratile cilia, and in the general characters of the alimentary canal and reproductive apparatus, it differs in very important points. Not only has it marginal tentacles and a nucleated epidermis, but it has a remarkable

\* Macleay Memorial Volume, 4to, Sydney, 1893, pp. 153-8 (1 pl.).



buccal proboscis, which is highly extensile, and is armed at its extremity with a minute stylet. While the tentacles and epidermis appear to ally it to the Temnocephalæ, it differs from them in having an anterior sucker, and a bursa copulatrix, as well as in wanting contractile excretory sacs.

### δ. Incertæ Sedis.

**Rotifers of the Rhine.\***—Herr R. Lauterborn has for some years been studying the fauna of the Rhine and the associated basins. At present he reports on the Rotifers, of which about 100 species were found. These he discusses in relation to their habitats in flowing or stagnant water, &c. The following new forms are described:—*Mastigocerca hudsoni* sp. n., *M. setifera* sp. n., *Chromogaster testudo* g. et sp. n., *Dictyoderma hypopus* g. et sp. n., *Brachionus rhenanus* sp. n.

**Alpine Rotifers.†**—Dr. O. E. Imhof notes the occurrence of *Floscularia regalis* and *Melicerta Janus* in Alpine lakes. They have hitherto been found in England only. Two species of *Notholca*, *N. labis* and *N. scapha*, are also notable finds. Altogether fifteen species of Eurhalyine Rotifers have been found in lofty water-basins of central Europe. Three have a very wide distribution: *Polyarthra platyptera* in twenty-six Alpine lakes, *Anuræa cochlearis* in sixteen, and *Notholca longispina* in forty-one. The author touches lightly on the problems raised by the fauna of these high-lying lakes, but a full discussion is promised.

**New Rotifers.‡**—Mr. J. Hood describes *Floscularia spinata*, which is distinguished by the presence of short spines on the circumference of the coronal cup; *Polyarthra aptera* differs from *P. platyptera*, the only other known species of the genus, by its want of the lateral appendages; *Brachionus tridens* is marine in habitat, and is chiefly peculiar for having only three spines on the occipital edge of the lorica.

Mr. D. Bryce § describes *Metopidia parvula* from Epping Forest; it is only 1/350 in. when extended.

### Echinoderma.

**Ophiuroids of North Sea.||**—Mr. J. A. Grieg gives an account of the twenty-four species and one variety of Ophiuroids collected during the Norwegian North-Sea Expedition. The absence of genital fissures in *Ophiopus arcticus* is confirmed; the fold noticed by Lyman appears to be a scar due to repeated ruptures, for while the species is perfectly capable of reproduction when it has a disc-diameter of 3 mm., the fold is not found in any individual which is not, at least, twice as large.

**Ophiopus arcticus.¶**—The structure of this species has also been investigated by Herr T. Mortensen, who points out that of the species which have been said to resemble *Ophiopus*, *Ophiomusium pulchellum* and *O. flabellum* have no bursæ at all, and must be placed in a special

\* Zool. Jahrb. (Abth. Syst.), vii. (1893) pp. 254-73 (1 pl.).

† Biol. Centralbl., xiii. (1893) pp. 607-12.

‡ Journ. Quek. Club, v. (1893) pp. 281-3 (1 pl.). § Tom. cit., pp. 284 and 5.

|| Den Norske Nordhavs-Expedition, xxii. Ophiuroiden, fol., Christiania, 1893, 41 pp., 3 pls., and 1 map.

¶ Zeitschr. f. wiss. Zool., lvi. (1893) pp. 506-28 (2 pls.).

genus; *Ophiopus* has very rudimentary bursæ, while *Ophiocymbium cavernosum* and *Ophiothammus vicarius* have true bursæ; as to the distinction drawn by Lyman between a "crease" and a "bursa," it does not exist morphologically.

The opening of the ovary of *Ophiopus* is at its tip, and is formed below the first ripe egg; the openings are not surrounded by epithelium; as they are formed there is an absorption of a calcareous plate and rupture of the fibrillar connective tissue. Herr Mortensen thinks that this species never attains a larger size than a disc-diameter of 5 mm.; it is only sexually mature once, and dies after oviposition.

**Silurian Crinoids.\***—Mr. F. A. Bather begins a detailed study of "The Crinoidea of Gotland," with "Part I. The Crinoidea Inadunata," in which forty species, belonging to ten genera, are systematically described. The work supplements and corrects the *Iconographia Crinoideorum*, &c. of Angelin, which is regarded as "splendide mendax"; but its chief interest lies in the morphological details described and illustrated. The discovery of the anal tube of *Pisocrinus* necessitates a fresh orientation of the radii in this and allied genera. Similarly an investigation of the evolution of the Calceocrinidæ, based largely on specimens from rocks in America older than those of Gotland, shows how this aberrant family can be brought into line with the Heterocrinidæ. The structure of the cup in *Herpetocrinus* is correctly described for the first time, and the minute structure of its peculiarly modified stem is illustrated and explained. It now seems certain that many of the Inadunata with Monocyclic base are all built upon one plan, having certain radials bisected and not others. Such genera were formerly supposed to differ in fundamental structure and were divided between Larviformia and Fistulata. The author considers that such a division has no logical basis, and prefers to erect the suborders of Inadunata "Dicyclia" and "Monocyclia." Apart from questions of homology, minor points of morphological importance are described for the Calceocrinidæ, such as the hinge, supplementary or patelloid plates, the anal tube, and the peculiarly complicated arm-branching. Several of the Gotland species of *Calceocrinus* are shown to present a very perfect evolutionary series. Under the Dicyclia we have first a thorough revision of *Homocrinus*, now first known from Europe. Under *Euspiocrinus* and *Cyathocrinus* a description of the various modifications of the tegmen and of the madreporite is given; but the author prudently declines to advance any homologies. It is suggested that *Gissocrinus* is not so akin to *Cyathocrinus* as has always been supposed, and it is shown that the fusion of the infrabasals in this genus is so irregular that no morphological importance can be attached to it, nor can theories of orientation be based on it. In dealing with *Gissocrinus* and *Cyathocrinus* Mr. Bather gives elaborate dissections of the brachials and ambulacra; the latter were often very complicated, and were provided with articular facets and with a nerve-supply from the aboral nervous system.

There is a note on the colour of fossils, à propos of the differences seen to exist between species of *Cyathocrinus*. *Streptocrinus* is a little-known but a singularly interesting form; it differs from all known

\* Kongl. Svenska Vet.-Akad. Handl., xxv. (1893) No. 2, 200 pp. and 10 pls.

Crinoids in the possession of "false pinnules," that is to say structures apparently resembling pinnules but springing from the middle of the sides of the brachials, not from their distal angles, and often being one on each side of a single brachial. So inexplicable is this arrangement that, in another part of this very paper, the author stigmatizes it as "an evolutionary impossibility." Not the least valuable part of this monograph are the very beautiful drawings by Mr. G. Liljevall, which are superior to all illustrations of fossil Crinoids that we have ever seen.

#### Celentera.

**Development of *Pelagia*.**\*—Prof. A. Goette finds that the alleged contrast between *Pelagia* and *Aurelia*, as regards development, does not exist. The larva of *Pelagia noctiluca* falls short of a *Scyphostoma* only in the absence of tentacles and funnel-muscle; the whole internal structure is that of a reduced *Scyphostoma*. One may regard *Aurelia*, *Cotylorhiza*, and *Pelagia* as three stages in the reduction of the Anthozoon-like ancestral form of the Scyphomedusæ.

**Reappearance of *Limnocodium Sowerbii*.**†—Prof. E. Ray Lankester makes the appearance of this freshwater Medusa in the Sheffield Botanic Gardens the text for an interesting note of what is certainly known as to its history, and points out that we have still to learn how the polyps which give rise to the Medusæ themselves originate.

#### Porifera.

**Studies on Spongillidæ.**‡—Dr. W. Weltner begins with a description of the structure of the gemmule as observed by himself and by others. The shell consists of several layers:—(1) an internal chitinous cuticle with a pore, or pore-tube, or several pores, closed during winter; (2) an air-containing layer, probably hydrostatic, and containing the characteristic spicules; and in some cases (3) an external cuticle. The germ within consists of numerous closely packed uniform cells, whose plasma contains many refractive yolk-granules. In each cell there is at first a single nucleus, but in many cases two or more appear, perhaps by direct nuclear division. The changes within the germ before it emerges from the cell, and its behaviour in liberating itself are then discussed.

The green gemmules of *Euspongilla lacustris* are described in detail. The zoochlorellæ are associated with some plasma in addition to the chlorophyll, and they are absent from some cells of the gemmule as from some cells of the adult. As to the brown pigment of *Spongilla fragilis*, Weltner notes that it is apparently affected by light, and lies in granules in some of the internal cells of the sponge. When this sponge shows green colouring, as it sometimes does, zoochlorellæ are present. The brown granules are absent in sponges living under stones, and are probably closely allied to the brown pigment of *Hydra fusca*.

Weltner then gives the results of a number of experiments on the influence of cold on the gemmules. Many are not killed after remaining

\* SB. K. Preuss. Akad. d. Wiss., 1892, pp. 853-61.

† Nature, xlix. (1893) pp. 127-8.

‡ Arch. f. Naturgesch., lix. (1893) pp. 245-84 (2 pls.).

for a considerable time in ice. Observations on the development of deformed sponges show that larvæ for the most part bereft of their ectoderm may grow into young sponges.

**Revision of Hyalonematidæ.\***—Prof. F. E. Schulze discusses this interesting family, contrasting the genera, and giving diagnoses and tabular keys of the species, 6 of *Pheronema*, 2 of *Poliopogon*, 20 of *Hyalonema*, and *Semperella Schultzei*. He expresses his conclusion as to the phylogenetic relations of the genera in this scheme.

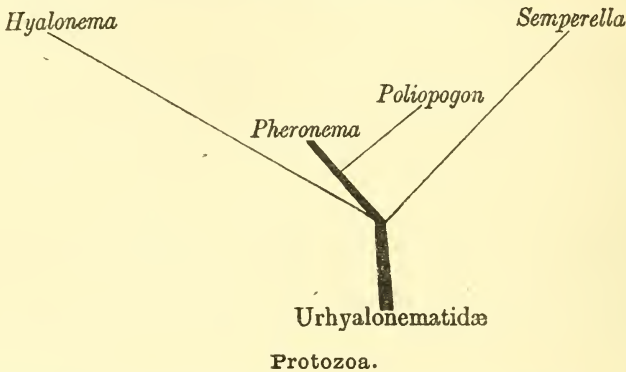

**Physiological Significance of Cell-nucleus.†**—Herr M. Verworn, from an examination of some marine Radiolaria, comes to the conclusion that portions deprived of the central capsule are able to again become complete spheres, and for some time to exhibit normal formation of pseudopodia, until they die down under the influence of certain degeneration-phenomena. Parts without a capsule may be saved by the introduction of a central capsule, even though it be that of another individual, and isolated central capsules are able to become regenerated into complete individuals by the fresh formation of pseudopodia, gelatinous envelopes, vacuolar layer and pigment. Isolated non-nucleated capsular contents may, under suitable conditions, live for a time, and exhibit normal formation of pseudopodia, and central capsules which have not been much injured, but whose nucleus is extirpated, may live still longer; during this period they regenerate a layer of pseudopodia, secrete a definite quantity of gelatinous substance, and begin to form vacuoles. Isolated nuclei, in all cases, die after a more or less short period, without exhibiting any regeneration-phenomena.

The author's views as to the importance of the nucleus may be judged from his statement that the physiological significance of the cell-nucleus depends on its metabolic relations to the rest of the cell-body. It is only by these that it possesses any influence on the function of the cell.

**A New Heliozoon.‡**—Prof. C. Sasaki describes a small marine Heliozoon, which he names *Gymnosphaeria albida* g. et sp. n. In the

\* SB. Akad. Preuss. d. Wiss., 1893, pp. 541-89.

† Arch. f. Ges. Physiol., li. (1892) pp. 1-118 (6 pls.). See Bot. Centralbl., lv., (1893) pp. 332-4.

‡ Jenaische Zeitschr. f. Naturwiss., xxviii. (1893) pp. 45-52 (1 pl.).



absence of skeleton and in being polynuclear it agrees with *Actinosphaerium*, but the plasma is not vacuolated, and there is a definite centre from which the axial filaments radiate. The diameter does not exceed .14 mm. Three layers—medullary, cortical, and enveloping—are described. Fission and conjugation (binary and multiple) were observed.

**A New Vorticella.\***—Dr. F. Römer describes *Vorticella vaga* sp. n., an unstalked species. Its internal structure is like that of other species, and the external characteristics are only slightly divergent. It is pear-shaped or bell-shaped, with a posterior ring of cilia in a shallow groove, with the usual adoral spiral, with horseshoe-shaped macronucleus, and two contractile vacuoles which empty themselves about once every minute. Longitudinal division was observed, and encystation, but no conjugation.

**Parasites of Cyclopidae.†**—Dr. W. Schewiakoff describes *Tokophrya cyclopium* Cl. and L., one of the Acinetæ, an ectoparasite of *Cyclops* and *Gammarus pulex*, and *Trichophrya cordiformis* sp. n., on *Cyclops phaleratus*; and gives diagnoses of the four known species of *Trichophrya*. In many freshwater Cyclopidae certain endoparasitic Sporozoa are common, occurring in amoeboid, encysted, and spore-forming states. That these are Myxosporidia the author doubts, nor does he find that they correspond with the forms which Henneguy and Thélohan have described as *Thelohania* g. n., but what they are he does not decide.

**Polymorphism of Peridinium acuminatum.‡**—M. G. Pouchet shows chiefly by a figure the extraordinary polymorphism of this species. At least eight distinct types can be recognized, and of these at least three should, in the present mode of systematically classifying Peridineæ, be placed in another genus.

**Classification of Sporozoa.§**—Sig. Mingazzini proposes the following new classification:—

Body formed by one segment	{ Coccidiea .. Monocystidea	{ Rounded or ovate, immobile, not conjugating, living in cells and tissues. Variable in form, mobile, generally free. If conjugation obtains it is almost always by apposition.

\* Biol. Centralbl., xiii. (1893) pp. 464-7 (2 figs.).

† Bull. Soc. Imp. Nat., 1893, pp. 1-29 (1 pl.).

‡ Comptes Rendus, cxvii. (1893) pp. 703-5 (1 fig.).

§ Ricerche Lab. Anat. Norm. Univ. Roma. See Biol. Centralbl., xiii. (1893)

**Amœbæ in Abscess of Jaw.\***—Dr. S. Flexner records a case of abscess of the lower jaw in which amœbæ were found in the pus on microscopical examination. The pus evacuated contained a large number of bacteria, pus-cells, detritus, red-corpuscles, and larger cells possessing the power of altering their form. These cells, recognized as Amœbæ, were most numerous in the thicker portion of the discharge. The author describes the parasite under two forms, the mobile and the resting. In the resting state they were either round or oval, and more highly refractive than leucocytes. No division into ectosarc and endosarc was observed, but vacuoles were seen in both the resting and active conditions. The movements were progressive in character, consisting in the extension and retraction of pseudopodia. The pseudopodia were usually blunt. The peripheral zone of protoplasm was homogeneous and less refractive than the central part. The contents of the Amœba consisted of granular material, vacuoles, and red-corpuscles.

**Muscle Degeneration in Barbel from presence of Myxosporidia.†**—M. P. Thélohan, who has made repeated investigations into the Myxosporidia disease of the barbel (*Barbus fluviatilis*), states that the presence of Myxosporidia in muscle leads to a vitreous degeneration of the fibres. The degenerated fibres are thoroughly destroyed by the action of phagocytes, and in consequence become transformed into fibrous tissue, and hence the spores of the Myxosporidia are eventually found enclosed in fibrinous cysts. An outbreak of tumours on the body of the barbel is not of unfrequent occurrence. From these tumours is evacuated a mass containing spores and not unlike pus; but this affection is the result of the presence of a large bacillus which rapidly liquefies gelatin, forming large white or yellowish-white colonies. It is easily stained and inoculated on rabbits, producing local abscesses. In the degenerated muscular tissue of barbel affected with myxosporidia disease the bacillus finds favourable conditions for its development.

**Sarcosporidia of the Gecko, Sheep, and Swine.‡**—Dr. A. Bertram describes the Sarcosporidia found in the muscular fibres of *Platydictylus facetanus* as tubes 2 mm. long and 0.4 mm. broad, which are enclosed in a bilaminated investing membrane; from the inner layer proceed membranous processes to the interior of the tube and form a system of closed chambers, of which those situated peripherally are quite filled with sickle-shaped bodies 0.003–0.004 mm. long; towards the centre the number of spores materially diminishes, and many of the central chambers merely contain granular masses. Earlier developmental stages were not observed.

Researches as to spore development of *Sarcocystis Miescheri*, a sarcosporidium found in the muscle of pigs, were without result. These formations are also invested with a double membrane, the thickness of which is not dependent on the size of the tube. As in *Sarcocystis platydictyli* there is a system of cavities filled with sickle-shaped bodies heaped up into balls.

\* Johns Hopkins Hospital Bull., iii. (1892) pp. 104–6.

† CR. Soc. Biol. Paris, v. (1893) pp. 267–70. See Centralbl. f. Bakteriol. u. Parasitenk., xiv. (1893) p. 532.

‡ Zool. Jahrb. (J. W. Spengel) Abth. f. Morph., v. (1892) pp. 581–604 (3 pls.). See Centralbl. f. Bakteriol. u. Parasitenk., xiv. (1893) pp. 499–500.

The sarcosporidia of sheep (*Sarcocystis tenella*) and the large psorosperm-sacs are, according to the author, stages of one and the same species; their structure is very much the same as in the other forms. In the youngest stage these may be seen in some places beneath the cuticular cells (sporoblast mother-cells) from which sporoblasts are produced by nuclear fission and simultaneous division of the plasma; the latter are cells with homogeneous plasma and large nucleus. The cells derived from these mother-cells form ball-like aggregations, and from these are produced in their turn sickle-shaped bodies. In the medium-sized tubes, cell-division, ball-formation, and growth of the tube in the longitudinal direction of the muscle-fibres are continually taking place. As soon as the resistance of the sarcolemma is removed by the size of the parasite cell-division and sheath-formation take place at the periphery, that is to say, the sarcosporidium-tube becomes a psorosperm-sac. Why the sarcosporidia should attain a greater size in the muscles of the larynx, tongue, and œsophagus than elsewhere, as for example in the heart, is unknown.

The author appends some remarks on tubes which he has observed in Rotatoria (*Brachionus*). Their development could be followed, but whether they were related to the Sporozoa or to the Chytridiaceæ was uncertain.

**Psorosperms of Darier's Disease.\***—Dr. W. Petersen considers that there is no doubt that the "corps ronds" and "grains" met with in Darier's disease, are not psorosperms, but that they are degeneration forms of the epidermic cells; for between the forms in question and the epidermic cells there is every variety of transition forms. The cell-inclusion appearances are only rarely met with, and these are easily explicable on mechanical grounds. These appearances are not of constant occurrence in Darier's disease, and the same or similar appearances are found in other cases of hyper- and para-keratosis, where their origin is still more clear. They contain at definite stages keratohyalin and eleidin, and no kind of preparation shows appearances resembling the developmental stages of known psorosperms. Inoculation and cultivation experiments fail.

From the foregoing it would appear that the author does not admit the usually accepted facts, and therefore his inferences differ altogether from those who see in these appearances evidence of a parasite.

\* Centralbl. f. Bakteriol. u. Parasitenk., xiv. (1893) pp. 477-88 (1 pl.).



## BOTANY.

A. GENERAL, including the Anatomy and Physiology  
of the Phanerogamia.

## a. Anatomy.

## (1) Cell-structure and Protoplasm.

**Nuclear Division in the Pollen-mother-cells of *Lilium Martagon*.**\*—Prof. J. B. Farmer finds that when the pollen-mother-cells in this plant are dividing, there are scattered in the cytoplasm a number of granules, and that these granules are coloured by those stains which differentiate the chromatic elements of the nucleus. They occur for the most part, though by no means exclusively, in the region of the achromatic spindle, and are obviously related to the spindle-fibres, marking the position of attraction-centres for portions of the spindle, which is thus broken up and becomes multipolar. The structure resembles the multipolar spindles observed by Strasburger in endosperm-cells, and a similar behaviour of dividing cells has been observed in animals. When preparing for division, the nucleus contains a nucleole of enormous size, which itself usually encloses several endonucleoles. Frequently this nucleole subsequently breaks up into a number of granules, which have precisely the same staining properties as those which occur in the cytoplasm.

**Karyokinesis in Pollen-mother-cells of *Larix*.**†—Herr W. Bieliajew finds the pollen-mother-cells of *Larix* to be a very favourable object for observing the various stages in karyokinesis; since they are large, and contain but little chromatin. *Mutatis mutandis* the processes correspond very closely to those in *Fritillaria Meleagris*.

**Nucleus of Germinating Seeds.**‡—From experiments made on *Lupinus luteus*, *Pisum sativum*, and *Zea Mays*, Herr M. Raciborski finds that, during the swelling of the seed in germination, the nuclei increase in size and become more and more rounded. The protoplasm of the nucleus appears to be homogeneous; during germination the chromosomes are ill-defined; the chromatin-framework makes its appearance suddenly in the whole of the nucleus. Small vacuoles appear in the protoplasm, increase in size, and coalesce. The protoplasm and the nucleus of the dormant seed takes up staining reagents without fixing much more readily than those of the germinating seed.

**Anatomy of the Cell in Fungi and Filiform Algæ.**§—Herr W. Wahrlich has established the existence of protoplasmic connection between the cells in all Fungi examined, with the single exception of *Oidium lactis*; not only between the vegetative cells of the hyphæ, but also between the asci and the ascospores, and in some cases between the

\* Ann. Bot., vii. (1893) pp. 392-6 (2 figs.).

† SB. Warschauer Naturf.-Gesell., 1892, 6 pp. See Bot. Centralbl., 1893, Beih., p. 446.

‡ Anzeig. Akad. Wiss. Krakau, 1893. See Bot. Centralbl., lv. (1893) p. 159.

§ St. Petersburg, 60 pp. and 3 pls. (Russian). See Bot. Centralbl., lv. (1893) p. 363.



cells of multicellular spores. In all cases the septum exhibits a simple central pore traversed by a string of protoplasm of uniform breadth. The protoplasm of the string was frequently seen to be of a granular structure. The pore is not formed by resorption of a portion of the membrane, but exists from the first. This is especially well seen in young cultures of *Achorion Schaenleinii*, and was also evident in cell-formation by budding. In a number of filiform Algæ—*Spirogyra*, *Ulothrix*, *Edogonium*—protoplasmic connection between the cells was also established.

The septum does not arise from a circular thickening of the side-wall, gradually penetrating into the cell-cavity; but a new membrane is formed round the protoplasm-body, apparently from its parietal utricle; and, as the protoplasm becomes constricted, this follows its contour, until, when it finally divides, each daughter-cell is surrounded by its own layer of cellulose. The layers of which the membrane of filiform Algæ are composed are "so many special membranes, which belong to the successive encapsuled generations of cells.

From the absence of these protoplasmic connections in those organisms in which each cell is independently nourished—*Oidium* and some filiform Algæ—the author concludes that they are the agents for the transport of food material, by means of which the granular protoplasm is carried from cell to cell. This was observed directly in the mycelium of *Eurotium repens*.

**Pectic Substances in Tissues.\***—M. L. Mangin recapitulates the conclusions arrived at in previous papers respecting the constant presence of pectic substances in the tissues of plants, and the part which they play in the composition of the cell-wall. When a new cell-wall has been completely formed, it always possesses a central lamella composed of insoluble pectates and destitute of cellulose, flanked on each side by secondary lamellæ composed of cellulose and pectic substances. The formation of intercellular spaces in tissues is explained by the readiness with which pectic acid is transformed into isomeric substances which are more or less readily converted into mucilage. These spaces are frequently clothed with a layer of calcium pectate, probably formed by a filtration through the cell-wall resulting from osmotic pressure. The insoluble pectates form a cementing substance by which the particles of cellulose are held together during the formation of the cell-wall. The dissociation of tissues may be effected by organisms which are nourished by pectic substances, such as *Bacillus amylobacter*.

**Silicified Thickening of Cell-wall.†**—Herr A. Zimmermann finds in the epiderm of the leaf of *Cyperus alternifolius*, peculiar projections, usually hemispherical and of circular or elliptical outline. They occur especially on the side-walls, and frequently extend to several cells. They consist almost entirely of silica, with a matrix of cellulose, and contain no lime. The author regards them as a transitional structure to true cystoliths, which have not yet been found in Monocotyledons.

\* Journ. de Bot. (Morot), vii. (1893) pp. 325-43 (2 pls.). Cf. this Journal, 1893, p. 495.

† Beitr. z. Morph. u. Phys. d. Pflanzenzelle (Zimmermann) (1893) p. 306 (1 fig.). See Bot. Centralbl., lv. (1893) p. 211.

## (2) Other Cell-contents (including Secretions).

**Myrosin in Plants.\***—According to Herr W. Spatzier, the presence of this substance is not confined to the Cruciferæ; it occurs also in certain genera and species of Resedaceæ, Violaceæ, and Tropæolaceæ. In the first of these it was found, as in the Cruciferæ, both in the seeds and in the vegetative organs; in the latter two in the seeds only. In the seeds and vegetative organs of Cruciferæ, and in the seeds of *Tropæolum*, myrosin occurs in special cells, the myrosin-sacs; in the aerial vegetative organs of Resedaceæ only in the guard-cells of the stomates. In the myrosin-sacs of the vegetative organs, this substance always occurs in the soluble form; while in the seeds it has the form of granules, which are again converted into the soluble state on germination.

Myrosin is an enzyme, and a product of the protoplasm. Its formation is not dependent on light. In its physiological functions it appears to stand midway between a product of excretion and a reserve-food-material; it is sometimes partially, but never wholly, resorbed, after having once been formed. It has, in common with potassium myronate and sinalbin, the property of splitting up glucosides. A substance similar in its properties to myrosin was found in the seeds of the Amygdaleæ.

**Spherocrystals of Euphorbia.†**—M. E. Belzung has investigated the nature of the spheroids and spherocrystals precipitated in the parenchyme of the cactus-like *Euphorbias*—*E. cærulescens*, *resinifera*, and *Caput Medusæ*—by the action of alcohol. The spheroids, which are at first amorphous, but are afterwards formed of radiating needles, are composed of a calcium malo-phosphate, soluble in water; the spherocrystals of calcium malate. Calcium malo-phosphate and calcium phosphate dissolved in malic acid appear to be the forms in which phosphoric acid is assimilated by the plant.

**Elaioplasts.‡**—Herr A. Zimmermann finds elaioplasts in a few scattered genera of Monocotyledons, most commonly in the flower- or fruit-stalk. They are usually spherical, though occasionally of other forms; there is generally only one in each cell; in the living cell they appear to be finely granular. They consist of a proteinaceous matrix with deposits of oily substances. They appear to be normal organs of the cells in which they are found.

**Vegetable Amyloid.§**—Herr E. Winterstein has studied the properties and reactions of the amyloid obtained from the seeds of *Tropæolum majus*, *Pæonia officinalis*, and *Impatiens Balsamina*, and contrasts them with those of starch. It is not acted on by diastase. Although coloured blue by iodine, it is probably not nearly related to starch, but belongs to the group of saccharo-colloids.

**Contents of the Trichomes of Myriophyllum.||**—Herr M. Raciborski has investigated the nature of the substance contained in the trichomes

\* Jahrb. f. wiss. Bot. (Pringsheim), xxv. (1893) pp. 39-78 (1 pl.).

† Journ. de Bot. (Morot), vii. (1893) pp. 221-9, 261-7 (7 figs.).

‡ Beitr. z. Morph. u. Phys. d. Pflanzenzelle (Zimmermann) (1893) pp. 185-97 (2 figs.). See Bot. Centralbl., lv. (1893) p. 151.

§ Zeitschr. f. Phys. Chemie, xvii. (1892) pp. 353-80. See Bot. Centralbl., lv. (1893) p. 149.      || Ber. Deutsch. Bot. Gesell., xi. (1893) pp. 348-51.

on the young leaves of *Myriophyllum*, and finds it to be probably of the nature of a glucoside. The chemical reactions are given in detail; they do not agree with those of tannin. Like tannin-vacuoles, these "glucoside-vacuoles" are protoplasmic secreting organs, and have much in common with elaioplasts.

**Colouring Matters of Underground Organs.\***—From observations made on several roots and tubers, M. E. Gain asserts that the formation of colouring matters in underground organs is not due to the direct influence of light, but depends on the accumulation in them of reserve food-materials. This accumulation is in general promoted by the dryness of the soil.

**Excretions of Calcium Phosphate.†**—Herr A. Zimmermann finds spherites of calcium phosphate in the living epidermal cells of the stem and leaves of a species of *Cyperus*, and in the fundamental parenchyme of older stems. They vary considerably in form—nearly round, irregular, or clustered—and consist of a nucleus of calcium oxalate, which is often crystalline, of a matrix of calcium phosphate, and of a delicate organic envelope.

### (3) Structure of Tissues.

**Relationship between Leaf-development and the Formation of Vessels.‡**—Herr L. Jost has investigated this subject in the case of a number of herbaceous and woody plants. The most marked results were obtained with *Phaseolus multiflorus*, where there is an abundant supply of reserve food-materials in the cotyledons. The leaf-traces of the first leaves are here completely distinct in the epicotyl, at least in the young plant, and some of them run from the leaf as far as the node of the cotyledons without anastomosing, and belong therefore entirely to the leaf. The results are on the whole not conclusive, but they show that the formation of tissues, and especially the development of the xylem, and its dependence on external and internal factors, is a very complicated process.

**Stoppages of Vessels.§**—Dr. A. Wieler has investigated the causes and the results of stoppages of vessels in the case of a large number of dicotyledonous and monocotyledonous plants. They may be caused either by living tissues (thyllæ), by gum, by resinous substances, or by excretions of calcium carbonate; while in many cases their nature is still unknown. They may occur in all kinds of vessels—annular, spiral, and pitted. The depositions of calcium carbonate are apparently purely physical; while in all other cases the stoppage appears to result from a vital process in the parenchymatous cells which adjoin the vessel. Stoppages occur normally in the vascular bundles, in the duramen and alburnum, and in the scars of fallen leaves and twigs. They hinder the transport of water into the vessels, and result in the current being confined, in the wood, to the last, or the few last, annual rings. They also protect the vessels from the injurious influences of atmospheric

\* Bull. Soc. Bot. France, xl. (1893) pp. 95-102.

† Beitr. z. Morphol. u. Phys. d. Pflanzenzelle (Zimmermann) (1893) pp. 311-7 (1 fig.). See Bot. Centralbl., 17. (1893) p. 272.

‡ Bot. Ztg., li. (1893) 1te Abtheil., pp. 89-138 (1 pl. and 4 figs.).

§ Biol. Centralbl., xiii. (1893) pp. 513-24, 577-607.



changes, and from the entrance of parasites. In a few cases stoppages of sieve-tubes were also observed.

**Aleurone-layer in the Seed of Grasses.\***—Mr. P. Groom states that the cells which compose this layer contain a rich store of oil in the protoplasmic network, whilst in the meshes of the protoplasm are numerous aleurone-grains, which form the greatest part of the cell-contents. In most other cases the aleurone-grains consist chiefly of globoids, with only envelopes of proteid matter. The aleurone-grain is hence often a receptacle for phosphates. In the oat, rice, rye, wheat, maize, sorghum, and *Coix lachryma*, the aleurone-layer is only one cell thick, while in barley it is for the most part several cells in thickness.

**Mucilage-layer in Flax-seeds.†**—M. L. Mangin has studied the development of the mucilage-layer in the seeds of *Linum usitatissimum*, and dissents from the statement of Brandza that it is a result of the transformation of starch contained in the cells of the integument. He finds, on the contrary, that it consists essentially of a substance allied to arabin, formed by gelification of layers of the external wall. It is always accompanied by a quantity of cellulose. The same results were obtained in *Linum grandiflorum*, *perenne*, and *campanulatum*.

**Anatomy of Magnoliaceæ.‡**—Prof. S. Matsuda has examined and describes in detail the anatomical characters of species belonging to four tribes of this order, viz. Magnoliæ, Illicieæ, Schizandreæ, and Trochodendreæ, with a view to ascertain whether there are any anatomical peculiarities characteristic of the whole order. He does not find any such, but on anatomical grounds classifies the genera in four groups, nearly coincident with the four acknowledged tribes.

**Anatomy of the Stem of Dioscoreaceæ.§**—M. C. Queva states that in the stem of the Dioscoreaceæ three vascular bundles proceed from the stem into each leaf. At the base of the petiole these branch into five, the intermediate ones being the result of the union of a lobe from the median bundle with one from a lateral bundle. The insertion of the axillary bud is determined by three vascular groups, a median and two lateral. The typical course of the bundles is seen in *Tamus communis*, where the phyllotaxis is  $3/8$  and sinistral; in *Testudinaria elephantipes* it is also  $3/8$ , but dextral; in the various species of *Dioscorea* the leaves are opposite or verticillate, or have a  $2/5$  phyllotaxis.

**Anatomy of the Acalypheæ.||**—Herr P. Rittershausen describes the anatomical structure of the stem and leaf of this tribe of Euphorbiaceæ, especially in reference to the laticiferous system. True laticiferous tubes occur only in a few genera,—septated in *Hevea*, unseptated in *Aleurites*, *Macaranga*, *Mallotus*, *Johannesia*, and *Pachystroma*. In all the genera there are rows of specialized cells which contain tannins and often latex-like substances. The stinging-hairs contain in their terminal cell an acicular crystal of calcium oxalate. Stellate stinging-hairs also

\* Ann. Bot., vii. (1893) pp. 387-92.

† Bull. Soc. Bot. France, xl. (1893) pp. 119-35 (1 pl.).

‡ Journ. Coll. Sci. Imp. Univ. Japan, vi. (1893) pp. 115-49 (4 pls.).

§ Comptes Rendus, cxvii. (1893) pp. 295-8.

|| 'Anat.-syst. Unters. v. Blatt u. Axe d. Acalypheæ,' Erlangen, 1892, xv. and 123 pp. and 1 pl. See Bot. Centralbl., lv. (1893) p. 164.



occur. The vascular bundles are simply collateral, and contain interxylary phloem only in a few genera. Raphides were never observed.

**Icacinaceæ.\***—Herr A. Engler discusses the value of anatomical characters in the classification of the genera of this natural order, nearly allied to the Olacaceæ. The genera are all characterized by the ovules being anatropous, and possessing two integuments; they are suspended in pairs from the apex of the loculus, presenting their raphe outwards and their micropyle upwards, the latter being covered by a swelling of the funicle. The four suborders, Icacinæ, Iodeæ, Sarcostigmateæ, and Phytocrenæ, may be distinguished by characteristics belonging to the structure of the vascular tissue; the aberrant Phytocrenæ being characterized by the mixed leptom-hadrom bundles in the leaves, the cambium always producing alternately tracheids and sieve-tubes on the outside.

#### (4) Structure of Organs.

**Anatomical Characters of Cæspitose Plants.†**—Dr. K. Reiche describes the characteristics of the plants which form dense tufts or cushions in the higher Cordilleras of Chile. They present the usual peculiarities of plants which require protection from excessive evaporation—a low growth, small leaf-surface, and thick epiderm. The cortical parenchyme is very strongly developed, with a central vascular bundle or woody ring to the stem.

**Insectivorous Plants.**—Prof. K. Goebel ‡ gives a *resumé* of the present state of our knowledge with regard to insectivorous plants. In the Droseraceæ the structure of the absorbing glands is similar, whether they are seated on tentacles, as in *Drosera*, *Roridula*, *Byblis*, and *Drosophyllum*, or not, as in *Dionæa* and *Aldrovanda*. In *Utricularia* the mode of germination and the development of the bladders are described in detail; the latter he regards as metamorphosed foliar organs. *Genlisea* and *Utricularia* have probably been derived from *Pinguicula*.

In another communication § Prof. Goebel states that the pitchers of *Genlisea* are modified leaves which have usurped the function of roots, the plant being entirely destitute of true roots. These modified leaves are at first destitute of chlorophyll, and present all the appearance of true roots. They gradually assume the form of two-armed pitchers, and the portion which appears above the soil becomes green. The pitchers are truly carnivorous.

**Female Flower and Fruit of the Chestnut.||**—Sig. F. Tognini describes in detail the structure of the female flower and of the fruit of *Castanea vesca*. Of the styler canals the central one is more developed than the others, and is the only one capable of fecundation. In the other styles the conducting tissue is replaced by a vascular bundle. Only one ovule in each ovary is fertilized.

\* SB. K. Preuss. Akad. Wiss. Berlin, 1893, pp. 247-69 (1 pl. and 8 figs.).

† Verhandl. Deutsch. Wiss. Ver. Santiago, ii. (1893) pp. 306-17.

‡ Pflanzenbiol. Schilderungen. Th. ii, Lief. 1; iv. and 160 pp., 57 figs. and 16 pls. Marburg, 1891. See Bot. Centralbl., liv. (1893) p. 270.

§ Flora, lxxvii. (1893) pp. 208-12 (1 fig.).

|| Atti R. Ist. Bot. Univ. Pavia, 1892. See Bull. Soc. Bot. France, xl. (1893) Rev. Bibl., p. 82.

**Staminal Appendages of Aristolochia.\***—According to Mdlle. Mayoux, the morphological value of the supra-staminal appendages of *Aristolochia* differs in the different species, according as the six stamens are equidistant or are arranged in groups of two. In the former case (*A. elegans*) the appendages must be regarded as six stigmas, originally bifid, which have become conerescent with the stamens; while in the latter case (*A. siphon*) three only of the stigmas have become so attached, the other three being suppressed.

**Stigmatic Lobes of Iris.†**—Dr. L. Celakovsky compares the petaloid stylar leaf of an *Iris* to the petal of a member of the *Sileneæ*, e. g. *Saponaria*; the two teeth of the latter, which run down into the wings on the upper side of the claw, correspond to the two stigmatic lobes in the former. The excrescences of *Saponaria* differ from those of *Iris* only in their growth being less vigorous than that of the main leaf.

**Cupule of Quercus.‡**—From an examination of an American oak (*Q. ilicifolia*), Dr. L. Celakovsky confirms his previous view that the amentaceous inflorescence, both of the *Amentiferæ* and of the *Cupuliferæ*, is derived originally from hermaphrodite flowers; and that, while the scales of the cupule are of a foliar nature, the cupule itself is axile. Certain oak-galls found in the axils of the leaves bear such a remarkable resemblance to an acorn enclosed within a scaly cup as to suggest the origin of the cupule from a hypertrophy resulting from the injury caused by the puncture of an insect.

**Development of the Seed.§**—Herr G. Kayser has investigated the development of the seed in those orders—especially the *Umbelliferæ* and the *Convolvulaceæ*—in which the ovule has only one integument, and in the *Onagraceæ*, *Sapindaceæ*, and *Tropæolacæ*, where it has two; with particular reference to the structure of the testa.

In all the monochlamydeous ovules examined the integument is from the first strongly developed in comparison with the nucellus, and this is especially the case with the pendent epitropous ovules of the *Convolvulaceæ*. The nucellus is in these cases absorbed very early by the embryo-sac, which lies immediately beneath the nuclear protuberance; scarcely a trace of it remains at the time of impregnation, and the micropylar canal is long and narrow. Only a portion of the integument is used up in the formation of the testa, the greater number of its layers having been consumed in the formation of the nutrient tissue. In the *Umbelliferæ* there remains in the testa nothing but the epiderm of the ovule.

In the seeds which result from dichlamydeous ovules there is a much greater variation in the mode of formation of the testa, and in the period of disappearance of the nucellus. In *Tropæolum* both the nucellus and the basal portion of the inner tegument disappear so early that at the time of impregnation the ovule has retained its dichlamydeous character only at its apex. In *Eriogonum* all the layers of both integuments are preserved in the testa; in *Æsculus* the leathery testa is the product of

\* Ann. Univ. Lyon, 1892. See Bull. Soc. Bot. France, xl. (1893) Rev. Bibl., p. 69.

† Oesterr. Bot. Zeitschr., xliii. (1893) pp. 269-72 (1 pl.).

‡ Tom. cit., pp. 272-7 (1 fig.). Cf. this Journal, 1887, p. 613.

§ Jahrb. f. wiss. Bot. (Pringsheim), xxv. (1893) pp. 79-148 (4 pls.).

the outer integument only; in *Tropæolum* the testa is derived from the outer layers of the chalaza. The seed of *Tropæolum* consists almost entirely of a chalazal tissue rich in protoplasm, the development of which is closely connected with that of the raphe and of its branches.

**Development of the Seed and of its Integument.\***—Pursuing his investigations on this subject, M. L. Guignard now discusses the natural orders Borragineæ, Labiatæ, Compositæ, and Valerianaceæ. In the Borragineæ the facts differ in the two tribes Borrageæ and Heliotropiæ. In the former the seminal integument is formed from the external layers (variable in number) of the integument of the ovule, and the endosperm disappears during maturation, with the exception of its superficial layer; while in the latter the integument of the seed is reduced to the external layer of that of the ovule, and a considerable thickness of endosperm remains. In the Labiatæ the presence or absence of endosperm corresponds to the classification into tribes. In the Compositæ the integument of the seed is developed from the single one of the ovule; one or two layers derived from the endosperm are always present in the ripe seed.

As a general *resumé*, it is stated that in those Dialypetalæ in which the ovule has a double envelope, the origin of the various parts varies, not only with the family, but even within the family. In all the natural orders here referred to, which are generally described as having exalbuminous seeds, there always remains, in the ripe seed, at least one layer derived from the endosperm, the "aleurone-layer" of authors. This is also the case in some other "exalbuminous" orders, e. g. Rosaceæ and Bignoniaceæ; while in a few others, such as Limnanthæ and Lythraceæ, the mature seed is entirely destitute of endosperm. In the Geraniaceæ the form of the embryo-sac corresponds to that which occurs in campylo-tropous ovules.

**Cuticle of the Seeds of Papilionaceæ.†**—Herr K. Schips has examined the structure of the cuticle and of the lining of the intercellular spaces in the testa of the seeds of a number of species of Papilionaceæ, and has come to somewhat different conclusions from those of Mattiolo and Buscalioni.‡ He states that the testa has a true cuticle, beneath which is frequently found a more or less strongly developed mucilaginous layer. Both these layers are distinct from the lining of the intercellular spaces, which is composed of three substances of different chemical and morphological characters. The outer of these layers is not identical with the cuticle; nor are its protuberances which project into the intercellular spaces identical with the mucilaginous layer.

To these remarks Drs. O. Mattiolo and L. N. Buscalioni § reply, supporting their former conclusions by fresh arguments. The outer layer of the investing membrane of intercellular spaces they consider as allied to a cuticle in its nature, though not necessarily identical with it. On the question of the mucilaginous layer, the reactions obtained by them do not in all cases agree with those of Schips.

\* Journ. de Bot. (Morot), vii. (1893) pp. 205-14, 241-50, 282-96, 303-11 (78 figs.). Cf. this Journal, 1893, p. 498.

† Ber. Deutsch. Bot. Gesell., xi. (1893) pp. 311-8.

‡ Cf. this Journal, 1893, p. 62.

§ Malpighia, vii. (1893) pp. 305-12.



**Protection of Leaves against Excessive Rainfall.\***—Prof. E. Stahl describes the contrivances (in Java) for the protection of leaves against the injurious effects of excessive rainfall in the tropics. One of the most frequent of these—especially characteristic of trees and shrubs growing in a very wet climate—is the prolongation of the apex of the leaf into a very long acuminate point, which serves as a conduit for carrying off the water from the upper surface of the leaf, as in *Ficus religiosa*. Another is the velvety structure of the upper surface of the leaf caused by the papillose form of the epidermal cells, a contrivance which prevents the moistening of the upper surface of the leaf, and facilitates rapid evaporation. The acuminate apex is never found associated with this structure, nor with a coating of wax on the upper surface. Other contrivances for carrying off the water are deeply channelled veins and rows of hairs on the stem. Heterophylly of the leaf, as in *Platynerium*, and reversal of the upper and under surfaces, are also of frequent occurrence. Protection against the mechanical injury caused by very heavy rain is afforded by a thick and leathery texture, by the leaf being split, as in *Musa*, or very deeply divided, as in most ferns, or by its great flexibility or pendent position.

**Branching of Borraginaceæ and Apocynaceæ.†**—Sig. A. Baldacci describes in detail the mode of branching in *Symphytum orientale*, with which also other species of the genus agree in essential points. It presents two peculiarities:—the constant elevation of the sympodiophorous axes and of their ultimate branches in respect to their supporting leaves; and the atrophied rudimentary cone of growth which indicates the termination of the principal axis.

In other genera of Borraginaceæ the author asserts that the statement of some authors that the branching is monopodial rests on erroneous observation. The inflorescence is always a sympode or dichotomous scorpioid cyme.

The species of Apocynaceæ examined exhibit, on the other hand, in all cases a monopodial branching. In *Vinca major* we find an axillary floriferous axis, a dormant axillary bud, and an enormously developed vegetative shoot.

**Haustoria of Phanerogamic Parasites.‡**—Mr. G. J. Peirce describes in detail the structure and development of four species of *Cuscuta*, *C. americana*, *glomerata*, *epilinum*, and *epithimum*, growing on different host-plants. In the same species of *Cuscuta* the growth of the haustoria differs in accordance with the structural peculiarities of the host.

In *C. americana*, if two or more stems twine around one another at a distance from the host, haustoria are not developed; but if one of them touches the host and sends haustoria into it, the others will also develop haustoria. The epiderm of the stem of the parasite bears no trichomes, and seldom contains stomates. The haustorium originates in the cortical parenchyme just beyond the pericycle, in a longitudinal row of cells, and consists of these and their offspring only. An opening into the host is effected by the exudation from the epidermal cells of

\* Ann. Jard. Bot. Buitenzorg, xi. (1893) pp. 98-182 (3 pls.).

† Bull. Soc. Bot. Ital., 1893, pp. 337-41, 393-401.

‡ Ann. Bot. vii. (1893) pp. 291-326 (3 pls.).



the parasite of a solvent which attacks and dissolves, first the epidermal and then the underlying cortical cells of the host. The haustoria are arranged in groups along the stem. From a morphological point of view the haustorium of *Cuscuta* is a lateral root, which develops into a structure, the bicollateral vascular bundles of which are united with the vascular bundles of the host by two strands of tracheids, and two strands of sieve-tubes and their companion-cells. Its xylem and phloem unite directly with the xylem and phloem of one or more bundles of the host; and an unbroken connection exists between the conducting tissues of the parasite and its host. The growing point of the haustorium is covered by a single layer of cells, which the author terms collectively the "sucker."

The structure and development of the haustoria in the other three species of *Cuscuta* examined differ in no essential respect from those of *C. americana*.

After the comparatively small amount of food stored in their seeds is consumed, the species of *Cuscuta* are absolutely dependent upon their hosts for food; and it is through the sieve-tubes in the haustoria, and their direct union with the sieve-tubes of the host, that the parasite obtains from it its elaborated substances and reserve food-materials.

Comparing these results with those obtained in other phanerogamic parasites, the author states that in those which do not contain chlorophyll (species of *Rafflesiaceæ* and *Balanophoreæ*) the structure of the haustoria is the same; they obtain the whole of their nutriment through the connection of their sieve-tubes with those of their host. In the mistletoe, on the contrary, the haustoria contain no sieve-tubes. It is a "water parasite," its host performing for it only the functions of a root,—absorption, conduction, and mechanical support.

**Bulbils of Dioscoreaceæ.\***—M. C. Queva describes in detail the structure of the bulbils on the stem of *Dioscorea Batatas* and *Helmia bulbifera*. They are always the result of the growth of a hypertrophied axillary bud; occasionally one will be the product of the concrecence of two buds.

**Tubers of Apios tuberosa and Helianthus tuberosus.†**—M. Nypels has examined the structure and development of the tubers in these plants, and states that in both their formation is mainly due to the closing of the non-differentiated elements of the central bundle, i.e. of the primitive central fibres and of the pericycle, secondarily also to the closing of the cortical parenchyme. The result is a hypertrophy of the cells of the pith, and a production of secondary parenchyme.

**Development of Arachis.‡**—M. A. Andouard describes the little-known bacterial tubercles in the root of *Arachis hypogæa*. All the parts of the plant contain a sugar, which appears to be exclusively saccharose, the largest proportion being in the root and stem. This is associated with starch, proteinaceous substances, oily substances, and pectic principles.

\* Comptes Rendus, cxvii. (1893) pp. 316-8.

† Bull. Soc. R. Bot. Belgique, xxxi. (1893) pp. 216-30 (2 pls.).

‡ Comptes Rendus, cxvii. (1893) pp. 298-300.

## B. Physiology.

## (1) Reproduction and Embryology.

Fertilization of *Claytonia*, *Phacelia*, and *Monarda*.\* — Mr. J. C. Willis has investigated the mode of pollination in two species of *Claytonia*, five of *Phacelia*, and three of *Monarda*, and describes the changes which take place in the position of the organs concerned.

*Claytonia alsinoides* and *sibirica* are both adapted for cross-pollination by insects; but self-pollination may sometimes occur in the later stages by the agency of sleep-movements.

All the species of *Phacelia* examined are proterandrous. *P. tanacetifolia* and *divaricata* have small inconspicuous flowers, which are apparently as a rule self-pollinated. *P. Whitlavia*, *Campanularia*, and *Parryi* have larger and more strongly proterandrous flowers, and are better adapted for cross-pollination.

*Monarda didyma*, *kalmiana*, and *fistulosa* have strongly proterandrous flowers, adapted for the visits of macroglossate Lepidoptera, though they may occasionally be self-pollinated during the movements of the stamens.

Germination of the Pollen of *Vinca major*.† — Dr. C. Acqua states that the pollen-grains of this plant germinate readily in about an hour in a 20 per cent. solution of sugar at the ordinary spring temperature. The apex of the pollen-tube is apparently formed entirely of hyaline protoplasm; the region of microsomes is lower down. At the commencement of germination the tube appears to be filled with non-granular protoplasm. The formation of new cell-wall takes place in the same way as Buscalioni has observed in other plants, and the author in the hairs of *Lavatera* ‡; but the larger microsomes appear not to take any direct part in the process; they probably break up into smaller bodies in the apical region; and these, interspersed among layers of hyaline protoplasm, are transformed into the substance of the cell-wall.

Dimorphism of the Flowers of *Convolvulus arvensis*.§ — M. C. Schilbersky points out the two forms of flower of this plant, one with longer, the other with shorter filaments. Both kinds of flower are self-pollinated by the aid of small Coleoptera, or cross-pollinated by Hymenoptera and Diptera. In the short-stamened flowers there is great abundance of fungus-hyphæ, which the author regards as belonging to an undescribed species which he names *Thecamphora Convolvuli*.

## (2) Nutrition and Growth (including Germination, and Movements of Fluids).

Influence of the Solar Rays on Growth.|| — M. G. Landel records a number of observations on plants both in nature and under cultivation. He finds the effect of a varying intensity of the solar rays to be the same in kind, though varying in intensity, in different plants, both as regards the number of flowers and the production of the red pigment. In some plants the pigment is well developed in the shade; in others,

\* Journ. Linn. Soc. (Bot.), xxx. (1893) pp. 51-62 (1 pl.).

† Bull. Soc. Bot. Ital., 1893, pp. 373-8

‡ See this Journal, 1893, p. 752.

§ Jub. Gedenkb. K. Ungar. Naturw. Gesell., 1892, pp. 623-34. See Bot. Centrall., 1893, Beih., p. 447.

|| Comptes Rendus, cxvii. (1893) pp. 314-6.

under the same conditions. the plant remains altogether green. In some the inflorescence is hardly affected by shade; in others the number of flowers is diminished, and in certain Compositæ the number of capitula. The effect of shade is always seen in a diminution of the reproductive power, either in a smaller number of seeds in the fruit, or in abortion of the fruits themselves.

**Influence of External Conditions on Growth.\***—Pursuing his investigations on the influence of the moisture of the soil on the growth of plants, M. E. Gain states that the power of absorption of water depends on the anatomical structure of the axial organs; and this is influenced by the nature of the soil. In a dry soil the fibro-vascular bundles are more numerous and further apart, ensuring a more perfect irrigation of the tissues; while in a moist soil the conducting tissue is protected externally by a sclerenchymatous layer. In a dry soil there is often a thick and continuous hypodermal collenchyme.

**Influence of the Pressure of Gases on Growth.†**—From a series of experiments made on about 50 different species, M. P. Jaccard states that a moderate increase beyond the normal pressure of the air, to the extent of from 3–6 atmospheres, promotes the growth of plants containing chlorophyll; and this is still more strikingly the case with a moderate decrease of pressure. An excessive change, on the other hand, in either direction retards growth. The results are somewhat different when the air is super-oxygenated. Very little morphological or histological change is caused by a moderate increase of pressure.

**Unequal Resistance of Plants to Drought.‡**—M. P. P. Dehérain shows that different plants—wheat and rye-grass—have a very different power of resistance to long-continued drought, from the difference in their capacity of putting out long roots which strike into the lower and moister layers of soil. The former of these two plants has a great advantage over the latter in this respect.

**Cell-union in Herbaceous Grafting.§**—Mr. J. S. Wright has produced successful grafts between the following herbaceous plants:—tomato on tomato, potato on tomato, geranium on geranium, geranium on tomato, (tomato on geranium failed), cactus on cactus, *Tradescantia zebrina* on itself and on tomato, the last an instance of grafting a monocotyledonous scion on a dicotyledonous stock. He states that in herbaceous grafting the union occurs in one of two ways; either by long exerted pressure holding old cell-walls together, and gradually causing them to cohere permanently; or through the development of meristematic tissue by one or both members of the graft, after which the boundary walls meet and unite through pressure.

**Growth of the Root.||**—Prof. A. Letellier propounds the following rules as governing the growth and direction of the root. The direction taken by the young portion of the root is that which corresponds to its

\* Bull. Soc. Bot. France, xl. (1893) pp. 142–5. Cf. this Journal, 1893, p. 356.

† Rev. Gén. de Bot. (Bonnier), v. (1893) pp. 289–302, 348–54, 382–8 (4 pls.); and Comptes Rendus, cxvi. (1893) pp. 830–3.

‡ Comptes Rendus, cxvii. (1893) pp. 269–72.

§ Bot. Gazette, xviii. (1893) pp. 285–93 (2 pls.).

|| Essai de statique végétale. See Bull. Soc. Belg. Micr., xix. (1893) p. 131.



position of stable equilibrium in hydrostatic suspension. In its natural direction the root always curves at a definite point, which presents a coefficient of minimum flexion, and the position of which depends on the order of the root. The orientation of the extremity of a root in hydrostatic suspension depends on the form of the extremity. The laws of gravity are sufficient to cause roots to grow in a vertical direction, and to bring them back to this direction when they have departed from it.

**Assimilation of Free Nitrogen by Plants.**—Herr B. Frank\* sums up the results obtained by the researches hitherto made on this subject, and reiterates his own previous conclusions, viz. that (1) The Leguminosæ assimilate free nitrogen, even when not in symbiosis with the tubercle-fungus. (2) The symbiotic fungus of Leguminosæ, when cultivated apart from its host-plant, develops vigorously when it can avail itself of an organic compound of nitrogen, but only feebly when nitrogen is presented to it in the elementary form. (3) The quantity of combined nitrogen which accumulates in the root-tubercles is not nearly sufficient to supply the amount which mature Leguminosæ, even when grown in soil destitute of nitrogen, possess in their seeds and other organs. (4) Plants not belonging to the Leguminosæ also assimilate free nitrogen, viz. fungi, certain algæ and mosses (especially species of *Oscillatoria*, *Nostoc*, *Ulothrix*), and certain flowering plants (*Avena sativa*, *Polygonum Fagopyrum*, *Spergula arvensis*, *Brassica Napus*, *Sinapis alba*, *Solanum tuberosum*, *Acer platanoides*). (6) The value of nitrates as manures is greatest when the plant is young and its power of assimilating free nitrogen is still very small.

On the other hand, Herr A. Petermann† states that fresh experiments have led him to doubt the correctness of his previous results, as far as barley is concerned, and rather confirm those of Hellriegel, Wilfarth, Schloesing, and Laurent, that the power of fixing free nitrogen belongs to the Leguminosæ alone, and is not possessed by plants belonging to other natural orders.

MM. T. Schloesing and E. Laurent‡ also give further experimental evidence that flowering plants not belonging to the Leguminosæ have no power of fixing free nitrogen. This property is, however, possessed by some algæ of low organization which occur commonly on the surface of the soil, such as *Nostoc*, *Phormidium*, *Cylindrospermum*, &c. It may, in these cases, be due to a symbiotic connection of the algæ with bacteria.

Experiments by Mr. C. D. Woods§ on several leguminous plants confirm previous results.

Prove|| suggests that the predisposition to form root-tubercles is transmitted to certain individuals by heredity, while it is absent from others.

\* Bot. Ztg., li. (1893) I<sup>re</sup> Abtheil., pp. 139-56.

† Bull. Acad. R. Belg., xxv. (1893) pp. 267-76. Cf. this Journal, 1893, p. 357.

‡ Ann. Inst. Pasteur, vi. (1892), pp. 824-40. See Journ. Chem. Soc., 1893, Abstr., p. 336.

§ Rep. Storrs School Agric. Exp. Stat., 1892, p. 17. See Bot. Centralbl., 1893, Beih., p. 303.

|| Zeitschr. Landwirthsch. Ver. Bayern, lxxii. (1892) pp. 85-100 (2 figs.). See Bot. Centralbl., lv. (1893) p. 185.



**Capillarity and Ascent of Sap.\***—From experiments on living and dead branches, the late Herr J. Boehm adduces fresh arguments in favour of his view that capillarity is the main agent in bringing about the ascent of sap and the absorption of water, and that the cells of the epiderm and mesophyll play the part of elastic vesicles in replacing the loss of water by suction from the vascular bundles.

**Internal Bleeding of Plants.†**—By this term Herr B. Jönsson understands the excretion of water from the cells into the intercellular cavities of plants. He has observed the phenomenon especially in the Balsamineæ and Cucurbitacæ, but also in other plants. It takes place chiefly in the leaf-stalk and stem, small drops making their appearance first of all on the walls of the parenchymatous cells which bound the intercellular cavities; and is the result of an increase in the moisture of the air accompanied by a fall of temperature.

(4) **Chemical Changes (including Respiration and Fermentation).**

**Intramolecular Respiration.‡**—Herr A. Amm has made a series of observations on this subject, chiefly on seedlings of the lupin and wheat, and on the leaves and petals of the marigold and rose. The carbon dioxide produced was carried off in a stream of hydrogen, precipitated in baryta water, and the baryta determined as oxalate. The experiments show that intramolecular respiration is a normal, not a pathological, process in plants. Representing the intensity of the intramolecular respiration by I, and that of the normal by N, the value of the fraction  $\frac{I}{N}$  increases with the development of the plant; is nearly constant with different organs of the same species; but differs greatly in different organs of the same plant. The minimum of temperature lies, with intramolecular as with ordinary respiration, below zero C.; the optimum temperature, with seedlings, is about 40° C., agreeing nearly with that for normal respiration; the maximum temperature for intramolecular respiration varies with the presence or absence of oxygen.

γ. **General.**

**Origin of Endogens.§**—Rev. G. Henslow argues in favour of the origin of Endogens from an early type of Exogens, the more immediate cause of their origin being an aquatic habit of life assumed by certain primitive exogenous plants. This view is supported by arguments drawn from various points of structure in exogens and endogens, especially from coincidences in this respect between endogens generally and aquatic and subaquatic exogens, and such of this latter class as may reasonably be supposed to have had an aquatic ancestry.

**Parasites on Algæ.**—Mr. G. Murray || gives an account of some of the animal and vegetable parasites known to attack various algæ, including the following:—The galls on *Vaucheria* and the malformations

\* Ber. Deutsch. Bot. Gesell., xi. (1893) pp. 203-12.

† Bot. Notiser, 1892, pp. 225-53. See Bot. Centralbl., lv. (1893) p. 245.

‡ Jahrb. f. Wiss. Bot. (Pringsheim), xxv. (1893) pp. 1-38 (2 pls.).

§ Journ. Linn. Soc. (Bot.), xxix. (1893) pp. 485-528.

|| Natural Science, ii. (1893) pp. 120-3.

on several seaweeds caused by animals; the Chytridiaceæ which inhabit freshwater and marine algæ; the algal parasites *Chlorochytrium* and *Phyllosiphon*; and the bacteria which cause tubercles on the fronds of Floridææ.

Mr. A. H. Church\* records the frequent occurrence of a pyrenomycetous fungus on the swollen fertile pods of *Ascophyllum nodosum*.

## B. CRYPTOGRAMIA.

### Cryptogamia Vascularia.

**Siliceous Deposit in Selaginella.**†—Mr. R. J. Harvey Gibson has examined the siliceous deposit in the cortex of a large number of species of *Selaginella*. He thinks it probable that the silica is an excreted product, and that calcium and magnesium are absorbed, at least in great part, in the form of soluble silicates, the silica being then eliminated in the soluble form.

**Sporophyte of Equisetineæ and Lycopodineæ.**‡—Prof. F. O. Bower discusses several theoretical points respecting the general morphology of the sporophyte of the Archegoniataæ, and the modes in which plants with numerous separate archesporia may have originated from plants of the bryophytic type. There is no definite position for the archesporium which applies to all Vascular Cryptogams. The author argues that there is no essential difference between the tissue which will form septa or trabeculae and that which will form spores, since they can mutually undergo conversion.

**Development of Marattia.**§—Prof. D. H. Campbell has investigated the development of *Marattia Douglasii*, and considers that his observations confirm the view that the eusporangiate ferns are primitive forms, and show that *Marattia* is the nearest form to the Hepaticæ yet examined, especially approaching the Anthocerotæ. The antherids most nearly resemble in structure those of *Equisetum*. The archegones are on the under side of the prothallium; and the embryo, in its development, retains its direct upward growth, and bursts through the prothallium, which remains surrounding the base of the young plant, and continues to supply nutriment to the sporophyte after the latter becomes independent.

**Structure of Lepidostrobos.**||—From a careful examination of *Lepidostrobos Brownii* Prof. F. O. Bower concludes that the synange of the Psilotaceæ is homologous with the sporangium of other Lycopods; that the sporangiophore is a branched leaf homologous with the simple sporophyll of *Lycopodium* or *Lepidostrobos*; and that the single fruiting axis of *Tmesipteris* or *Psilotum* is comparable to a lax lycopodinous strobilus. The lacunar structure which is so frequent in cortical tissues of various fossil lycopodinous plants he regards as attaining a specialized development in the trabeculae of *Selaginella*.

\* Ann. Bot., vii. (1893) pp. 399-400. † Tom. cit., pp. 355-66 (1 pl.).

‡ Proc. Roy. Soc., liv. (1893) pp. 172-6. Cf. this Journal, 1893, p. 761.

§ Bot. Gazette, xviii. (1893) p. 337.

|| Ann. Bot., vii. (1893) pp. 329-54 (2 pls.).

## Algæ.

**New Genera of Algæ.\***—Prof. J. G. Agardh publishes, as a supplement to his 'Species, genera, et ordines Algarum,' a detailed account of the genus *Callithamnion*, which he divides into sixteen genera or subgenera, of which the following are new:—*Microthamnion* (*C. interruptum*), *Platythamnion* (*C. heteromorphum* and *orbignianum*), *Acrothamnion* (*C. pulchellum*), *Heterothamnion* (*C. Muelleri*), *Gymnothamnion* (*G. elegans*), *Perithamnion* (*P. ceramioides*), *Ceratothamnion* (*C. Pikeanum*), *Lophothamnion* (*L. comatum*), and *Aristothamnion* (*C. purpuriferum*).

The following new genera are also described:—*Blastophye* (*Cryptonemia Wilsonis* and *Kallymenia phyllophora*), *Meredithia* (*K. microphylla*, &c.), *Hormophora* (*H. australasica* sp. n.), *Ozophora* (*O. California* sp. n.), *Leptosomia* (*Chrysymenia Cliftoni* and *gelatinosa*), *Leptocladia* (*L. Binghamiæ* sp. n.), *Erythronæma* (*E. ceramioides* sp. n.), *Amylophora* (*A. Coleæ* sp. n.), *Peltasta* (*P. australis* sp. n.), and *Amphiplexia* (*A. hymenocladoides* sp. n.).

The genera of Rhodomelaceæ are then described in detail and classified into eleven suborders, and the following new genus established:—*Cyclospora* (*C. Curtissiæ* sp. n.).

Descriptions are also given of a number of new species belonging to other families of seaweeds.

**Algæ of the Black Forest and Rhine Country.†**—Herr W. Schmidle states, in some preliminary remarks accompanying a classified list, that waters containing but little lime are especially rich in desmids, but contain few filiform algæ, while these abound in calcareous waters. The latter are often entirely barren of desmids, but sometimes afford some rare and little-known forms. A new genus of Palmellaceæ is described, *Kirchneriella*, separated from *Raphidium*; and the following new species:—*Kirchneriella lunata*, *Cladophora striata*, *Cœlastrum pulchrum*, *Cosmarium subcucumis*, *C. insigne*, *C. subpachydermum*, *C. lobulatum*, *C. subbroomei*, *Staurastrum nigræ sylvæ*.

**Pellicle of Algæ.‡**—Dr. S. Stockmayer describes a dense coat formed on overflow-water of the Danube, and composed of masses of *Microcoleus chthonoplastes* and *Calothrix parietina*, the latter a freshwater form found on rocks, walls, &c., the former properly a marine alga or halophyte.

**"Meteoric Paper."§**—Herr J. Istvánfi has examined the object which goes by this name obtained from several localities in Germany and Hungary, and finds it to be composed, in the different cases, of the following Algæ:—*Microspora floccosa*, with about thirty other species involved in its web; *Lyngbya turfosa*; *Cladophora fracta*; and *Sphæroplea annulina* in a fructifying condition.

**Pleurostichidium, a New Genus of Florideæ.||**—Herr F. Heydrich describes, under the name *Pleurostichidium Falkenbergii*, the type of a new genus of seaweeds from New Zealand, epiphytic on *Fucodium*

\* Acta Univ. Lund., xxviii. (1892), 182 pp. and 3 pls.

† Ber. Naturf. Gesell. Freiburg-i.-B., vii. (1893) pp. 68-112 (5 pls.).

‡ S.B. Zool.-Bot. Gesell. Wien, xliii. (1893) pp. 28-30.

§ S.B. Bot. Fachver. K. Ungar. Gesell. Naturwiss., March 8, 1893. See Bot. Centralbl., lv. (1893) pp. 395. Cf. this Journal, 1891, p. 777.

|| Ber. Deutsch. Bot. Gesell., vii. (1893) pp. 344-8 (1 pl.).



*chondrophyllum*, and places it in the tribe Polysiphoniceæ of Rhodomeleaceæ. The following is the diagnosis of the genus:—Thallus forming a very short spherical primary shoot, from which spring flat moderately stiff-branched dorsiventral secondary shoots, cartilaginous, consisting of a polysiphonous axis and 15–20 pericentral cells. Cystocarps spherical, shortly stalked, on the inner side of the secondary shoot; antherids in a similar position to the cystocarps, forming an ovoid or catkin-like shortly stalked mass; tetraspores in a similar position, in dorsiventral septated stichids, divided tetrahedrally. A peculiarity of the plant is that sexual organs in all stages of development are found on the same individual at the same time. It has no attachment-disc, the organs of attachment penetrating deeply into the host-plant.

**Laminariaceæ.\***—Prof. W. A. Setchell gives a *resumé* of the general structure of this family of Phæosporeæ, and a proposed classification of the nineteen genera now included in it under three tribes, as follows:—(1) Laminariideæ:—Fronds simple (except in *Thalassiophyllum*):—made up of two sub-tribes, Laminariæ (*Chorda*, *Saccorhiza*, *Laminaria*), and Agareæ (*Cymathære*, *Costaria*, *Agarum*, *Thalassiophyllum*, *Arthrothamnus*). (2) Lessoniideæ. Frond compound; new blades arising from the old by a splitting process at the transition-place:—two sub-tribes, Lessoniæ (*Dictyonereuron*, *Lessonia*, *Postelsia*, *Nereocystis*), and Macrocytææ (*Macrocystis*). (3) Alariideæ; Frond pinnately compound; sporophylls arising as outgrowths at the transition-place:—three sub-tribes, Eckloniæ (*Ulopteryx*, *Ecklonia*, *Eisenia*); Egregiæ (*Egregia*); and Alariæ (*Pterygophora*, *Alaria*).

**Chlorophores of Spirotænia obscura.†**—Dr. J. Lütkenmüller states that in young specimens of this desmid the chlorophores do not consist of parietal bands, as in *S. condensata*, but resemble essentially those of *Penium*. A central band, with a row of pyrenoids, passes through the entire length of the cell, and gives off towards the cell-wall lamellæ which are twisted spirally and thickened outwards. The structure of the cell-wall and of the gelatinous envelope agrees with that of *S. condensata*.

**Epiphytic and Endophytic Chætophoraceæ.‡**—M. J. Huber gives an exhaustive account of the endophytic and epiphytic genera and species of Chætophoraceæ. The epiphytic genera are six, viz.:—*Endoclonium*, *Herpoteiron*, *Ochlochæte*, *Pringsheimia*, *Uvella*, and *Chætopeltis*. *Endoclonium* is very nearly allied to *Stigeoclonium*, and several species included by authors under the former must be referred to the latter genus. Braun's genus *Aphanochæte* must be sunk in Nägeli's earlier *Herpoteiron*. *Ochlochæte* resembles *Herpoteiron*, with the hairs transformed into bristles; *O. dendroides* is probably identical with *Phæophila Floridearum*. A new species *O. ferox* is described epiphytic on *Chætomorpha Linum*. *Uvella* is destitute of hairs, and is nearly allied to the Ulvaceæ; *Chætopteris* exhibits an affinity with the Trentepohliaceæ.

The endophytic genera are eight, viz.:—*Chætonema*, *Acrochæte*, *Bolbocoleon*, *Gonatoblaste* g. n., *Endoderma*, *Phæophila*, *Blastophysa*, and *Chætosiphon* g. n. *Acrochæte* has not the sheathed hairs which have been

\* Trans. Connecticut Acad., ix. (1893) pp. 333–75.

† SB. Zool.-Bot. Gesell. Wien, xliii. (1893) pp. 38–9.

‡ Ann. Sci. Nat. (Bot.), xvi. (1892) pp. 265–359 (11 pls.).



attributed to it. *Gonatoblaste* is founded on a new species, *G. rostrata*, endophytic on a *Zygnema*. The zoospores germinate within the gelatinous envelope of the host, developing a hyaline bristle which is cut off by a septum, and sharply bent at the base. *Endoderma* is divided into two subgenera,—(1) *Entocladia*, in which the cells are destitute of hairs, and contain usually only a single pyrenoid; it is made up of a new species, *E. perforans*, endophytic on dead leaves of *Zostera*, together with others previously described; (2) *Ectochæte*, which includes one species hitherto known and two new ones,—*E. leptochæte*, endophytic on a marine *Chætomorpha*, and *E. Jadinianum* on a freshwater *Cladophora*. *Phæophila Floridearum* occurs on a great variety of marine algæ. *Chætosiphon* is founded on a new species, *C. moniliformis*, found on *Zostera* and associated with *Endoderma perforans*. The following diagnosis is given:—Thallus tubulosus, continuus, per cellulas lacunasque foliorum *Zosteræ marinæ* longe excurrans, irregulariter ramosus, septa cellularum perforans, ibique valde constrictus, extus setas longas hyalinas leniter contortas emittens. Chlorophora parietalia discoidea polyedria, pyrenoidea singula foveantia. Sporangia ex partibus thalli septo discretis formata; zoogonidia 2-ciliata, ex divisione contentus sporangii orta, per tubulum hyalinum emittuntur. *Blastophysa* and *Chætosiphon* form together a group presenting strong resemblances both to the Siphonocladæ and to the Valoniaceæ, for which the author proposes the name **CHÆTOSIPHONACEÆ**.

The epiphytic and endophytic groups are distinguished by the portion of the thallus which is in contact with the substratum being dorsiventral in the former, but not in the latter; the membrane is less mucilaginous in the latter than in the former. The hairs are enclosed in a sheath only when the thallus is disc-shaped. The cells of the epiphytic species have only one pyrenoid, while there are several in the endophytic species, with the exception of *Chætonomia*, *Gonatoblaste*, and *Entocladia*. The zoospores in each zoosporange are more numerous in the marine than in the freshwater species. A sexual mode of reproduction by isogametes has been observed in some genera.

**Zoospores of *Draparnaldia*.**\*—Mr. L. N. Johnson has observed the structure and the mode of formation and escape of the zoospores of *Draparnaldia plumosa*. Their production is confined to the branchlets, but to no particular part of them. The zoospores germinate freely, and no sign of conjugation between them was detected. Resting spores were also observed, which are probably modified zoospores, but differ from them in the absence of the pigment-spot and of the two contractile vacuoles.

***Chætomorpha Henningsii*.**†—Herr P. Richter has observed the escape of swarm-spores from this alga; they are sometimes formed in isolated cells, sometimes in several adjoining cells; they have no red eye-spot. The escape takes place through an opening in a previously-formed papilla. No conjugation of swarm-spores was observed. Some of the vegetative cells develop, at the end of the season, into akinetes. In addition to the ordinary mode of vegetative multiplication, a separa-

\* Bot. Gazette, xviii. (1893) pp. 294-8 (1 pl.).

† Hedwigia, xxxii. (1893) pp. 310-5.

tion of the filament sometimes takes place into two or more pieces, which may be compared to the hormogones of the *Phycocromaceæ*.

**Chlorocystis.**—Under the name *Chlorocystis Sarcophyci* sp. n., Miss F. C. Whitting\* describes a new endophytic alga which causes malformations in the frond of *Sarcophycus potatorum*. The endophytic cells produce large numbers of zoospores, sometimes more than 100 in each cell. *Chlorocystis* is nearly allied to *Chlorochytrium*, but differs in the zoospores being formed by free-cell-formation.

M. E. De Wildeman † has studied the structure of *Chlorocystis Cohnii* parasitic on a *Schizonema*. In its form and mode of growth it recalls certain Chytridiaceæ, and the author considers it probable that some genera included in this family of Fungi are descended from Algæ allied to *Chlorocystis*, which have lost their chlorophyll in acquiring a parasitic habit.

**Chlamydomonadineæ.**‡—Herr R. Franzé proposes to retain in this family only 5 out of the 17 genera at present placed in it, viz. *Chlamydomonas*, *Sphærella*, *Chlorogonium*, *Corbiera*, and *Carteria*; of which *Chlorogonium* forms a group by itself and the other four genera a second group. *Pithiscus* is united with *Carteria*; *Polytoma*, *Hymenomonas*, and *Spondylomorom* are referred to other groups of Flagellatæ; and *Polyblepharides*, *Pyramimonas*, and *Chloraster* are placed under the *Polyblepharideæ*. *Chlorangium* and *Physocytium* constitute a connecting link between this family and the Tetrasporeæ. The Chlamydomonadineæ have probably developed out of the Tetrasporeæ, and lead in one direction to the Volvocineæ, in another to the Conjugatæ.

### Fungi.

**Saprophytic Fungus becoming Parasitic.**§—Herr H. Zukal records a remarkable instance of a sudden change of habit from saprophytic to parasitic, in the case of a fungus *Sordaria fimicola*. This species and *S. bombardoides* were both cultivated on hare's dung; when some individuals of the former species attacked the latter, becoming parasitic on the peritheces, and completely destroying them. This was not for want of their ordinary nutriment, but apparently from preference.

**Fungus growing in a saturated solution of salt.**||—Herr H. Zukal records an instance of a fungus, *Halobyssus moniliformis*, growing in a saturated solution of sodium chloride, and producing conidia or chlamydo-spores. It would appear as if the protoplasm of the fungus exercised a greater attractive force over water than does sodium chloride.

**New Genera of Fungi.**¶—Herr H. Zukal describes the following new genera of Fungi:—

*Cleistotheca* (Perisporiaceæ). Peritheces without an ostiole, more or less spherical, single or in groups, but not confluent, black, opaque,

\* Phycol. Mem. (Murray) ii. (1893) pp. 41-6 (8 figs.).

† Bull. Soc. Belge Micr., xix. (1893) pp. 140-4.

‡ SB. Bot. Fachver. K. Ungar. Gesell. Naturwiss., Dec. 14, 1892. See Bot. Centralbl., lv. (1893) p. 392.

§ Oesterr. Bot. Zeitschr., xliii. (1893) pp. 277-9 (3 figs.).

|| Tom. cit., pp. 279-81 (1 fig.).

¶ Oesterr. Bot. Zeitschr., xliii. (1893) pp. 160-6, 211-15, 241-7 (2 pls.).

brittle, with thick coat, sessile on the surface of the substratum; asci broad; ascospores eight, large, divided, yellow-brown. *Stachybotrys* is a conidial form of this genus.

*Lecythium* (Hypocreaceæ). Without a stroma; peritheces solitary, soft, entirely superficial, flask-shaped, light blue-green, with long neck and distinct ostiole; asci linear, mixed with paraphyses; ascospores eight, fusiform, four-celled, colourless, with an appendage at both ends.

*Cyanocephalum* (Pyrenomycetes). Without a stroma; peritheces solitary, superficial, ovate or spherical, yellowish white, smooth, very hard, with a distinct ostiole at the apex; asci flask-shaped; ascospores numerous, very small, colourless, two-celled.

A new family of Pyrenomycetes is also established, the THELOCARPEÆ, with the following diagnosis:—Without a stroma; peritheces superficial, solitary or in groups, with a distinct ostiole at the apex; asci ventricose, flask-shaped; ascospores numerous, very small, two-celled, hyaline. It comprises the two genera *Thelocarpon* and *Cyanocephalum*, and is intermediate between the Hypocreaceæ and the Sordarieæ.

**Parasitic Fungi.**—M. A. Prunet\* describes the rhizoctone which attacks the roots of the lucerne, and which is known as *Rhizoctonia Medicaginis*. It develops within the tissues of the host sclerotes of two kinds, larger and smaller, and produces also an ascosporous form identical with *Byssothecium circinans*, *Trematosphæra circinans*, and *Leptosphæra circinans*.

Mr. L. H. Pammel† enumerates the parasitic fungi which attack the beet crop, including *Cystopus Bliti*, *Cercospora Betæ*, and *Rhizoctonia Betæ*.

Herr F. Ludwig‡ finds on beech-stumps a mucilaginous flux which he determines to be an oidium-form of *Ascobolus Costantini*.

Sig. F. Cava § has established the parasitic character of *Gibellina cerealis* on cereal crops. He also affirms the identity of *Septoria graminum* and *S. Tritici* as forms of the same species. *Phoma lophiostomoides* is not a true parasite. In the haulms of cereals he finds a new hyphomycetous fungus, *Acremoniella occulta*. On the leaves of barley he has also detected a new fungus *Ophiocladium Hordei*, the type of a new genus of Mucedineæ with the following diagnosis:—Hyphæ fertiles fasciculatæ, anguineo-tortuosæ; conidia acrogena, hyalina, continua. It bears a close resemblance to *Oidium anguineum*.

M. E. Prillieux|| finds that *Monilia Linhartiana*, parasitic on the quince, develops under cultivation an apothecial form very similar to the *Sclerotinia* parasitic on *Vaccinium*. He proposes therefore to call the fungus *Peziza Linhartiana*.

M. C. Schilbersky¶ finds, in the short-stamened flowers of the *Convolvulus arvensis*, a quantity of fungus hyphæ which produce yeast-like

\* Comptes Rendus, cxvii. (1893) pp. 252-5.

† Bull. Iowa Agric. Cult. Exp. Stat., No. 15, 16 pp. and 1 pl. See Bot. Centralbl., lv. (1893) p. 183.

‡ Forstl.-naturw. Zeitschr., 1893, 3 pp. See Bot. Centralbl., 1893, Beih., p. 398.

§ Zeitschr. f. Pflanzenkrankheiten, iii. (1893) 11 pp. and 1 pl.

|| Bull. Soc. Bot. France, xl. (1893) pp. 219-20.

¶ Jub. Gedenkb. K. Ungar. Naturw. Gesell., 1892, pp. 623-34. See Bot. Centralbl., 1893, Beih., p. 447.



cells bearing a close resemblance to *Saccharomyces apiculatus*. He names the fungus *Thecamphora Convolvuli* sp. n.

**Symbiotic Fungus of Ophioglossaceæ.\***—In all the species of *Ophioglossum* and *Botrychium* examined, Prof. G. F. Atkinson finds hyphæ of a symbiotic fungus in the cells of the cortical parenchyme of the root. Since the roots of the Ophioglossaceæ do not possess true root-hairs, this symbiotic organism probably plays an important part in the nutrition of the plant.

**Physiology of Penicillium Duclauxi.†**—Investigating the nature of the ferments formed by this fungus, MM. Bourquelot and Graziani state that it does not produce diastase, but can form invertin. The morphological character of the fungus, and its power of producing club-shaped structures are very greatly influenced by the kind of sugar contained in the culture-fluid. Galactose, which is not ordinarily assimilated, can be if a small quantity of glucose is added.

**Polymorphism of Cladosporium herbarum.**—M. de Janczewski ‡ has studied the history of development of this polymorphic fungus, and states that the peritheces identify it with *Leptosphæria Tritici*, which has both a *Phoma* and a *Septoria* form. The mycele, when transferred to a more nutritive medium, gives rise to *Hormodendron cladosporioides*. *Cladosporium* forms occur not only in *Leptosphæria*, but also in *Pleospora* (*Alternaria*), and in *Fumago*.

Sig. R. Pirotta § confirms this statement, and states that *Cladosporium herbarum* is a stage in the cycle of development of a Pyrenomycetous fungus belonging to the genus *Leptosphæria*, which has five conidial forms, three of them—*Cladosporium*, *Hormodendron* and *Dematium*—springing from conidiophorous hyphæ; the other two—*Phoma* and *Septoria*—from conidiophorous conceptacles.

**Calyciæ.||**—Herr E. Neubner has studied the structure of this, the lowest family of Lichens. There is never any hypothallus, the structure which has been described as such being a collection of foreign Algæ and Fungi. The first growth from the gonid is a thallus, and not a protothallus, and this becomes surrounded by filiform hyphæ; both these and the original gonid continue to divide and develop into a minute ball, which may be transported by wind or rain; or a number may collect, on the bark of trees, into a powdery mass. The most common mode of propagation is by soredes. The sexual organs are in a state of great degeneration; no pycnids were observed; the apothecies spring directly from the thallus. A formation of oidium-structures takes place, similar to that in the Basidiomycetes and Ascomycetes, but not previously observed in Lichens. The gonidial element belongs to the Pleurococcaceæ or to *Stichococcus*.

\* Bull. Torrey Bot. Club, xx. (1893) pp. 356-7.

† Bull. Soc. Mycol. France, viii. (1892) pp. 147-52. See Bot. Centralbl., lv. (1893) p. 326.

‡ Bull. Acad. Sci. Cracovie, 1892. See Bull. Soc. Bot. France, 1893, Rev. Bibl., p. 90. Cf. this Journal, 1890, p. 73.

§ Atti R. Accad. Lincei, ii. (1893) pp. 288-90.

|| Wiss. Beil. iv. JB. K. Gymn. Plauen, 1893, 12 pp. and 1 pl. See Bot. Centralbl., lv. (1893) p. 143.



**New Zymogenous Saccharomyces.\***—Sig. F. Cavara describes a disease which attacks the dura, *Sorghum Caffrorum*, due to a hitherto undescribed species of *Saccharomyces*, of which he gives the following diagnosis, with the name *S. Comesii*:—In cellulis vaginalium et culmorum *Sorghii* nidulans; mycelio hyphis cylindræis septatis constituto, hinc inde ramulos seu sporophora ramosa exhibente; conidiis acrogenis, solitariis v. catenulatis, cylindræis v. longe ellipsoideis,  $7-9 \times 2-3 \mu$ .

**Histological Structure and Development of Yeasts.†**—M. P. A. Dangeard finds that when *Saccharomyces cerevisiæ* is fixed with absolute alcohol and stained with hæmatoxylin, beneath the investing membrane there becomes evident a dense homogeneous layer of protoplasm which stains deeply. This protoplasmic mass encloses a vacuole and a nucleus, the latter limited by a well-defined membrane, and containing a nucleole. The nuclear plasma between the nucleole and membrane remains unstained, but not unfrequently shows chromatin arcs. The budding process may start from a part of the yeast right opposite to the position of the nucleus. The bud is at first almost spherical, and contains, like the mother-cell, protoplasm and a vacuole, the parent and offspring remaining united by a delicate cord-like attachment.

Hitherto the nucleus has remained passive, but now it moves towards the point of attachment of the bud, and there divides into two, usually by the direct method. The young nucleus has a nucleole and hyaloplasm, but no nuclear membrane, this not appearing until it has quite arrived within the daughter-bud. Even before separation has taken place, the mother-nucleus may move off towards a younger bud, of which several, though of different ages, may be present in the same cell.

**Laboulbeniaceæ.‡**—Mr. R. Thaxter describes a large number of new species of this order of Fungi, chiefly from America, including the following new genera:—

*Ceratomyces*.—Receptacle reduced, consisting of a small number of basal cells, above which it is directly continued by the basal cells of the perithece and antheridial appendage. Peritheces highly developed, the walls composed of four longitudinal rows of superposed cells, the outer row continued into a horn-like appendage. Antheridial appendage arising at the base of the perithece, composed of a series of superposed cells. Asci subclavate, 4-spored; spores fusiform or acicular, once septate, involved in mucus.

*Corethromyces*.—Receptacle reduced to a basal with two or three terminal cells, giving rise on one side to the free perithece, on the other to several long straight rigid cylindrical jointed appendages, which bear externally at short intervals numerous secondary appendages.

*Acanthomyces*.—Peritheces as in *Laboulbenia*, clearly differentiated from the receptacle. Main axis of the receptacle composed of superposed squarish cells, and, above its basal cell on the inner side, of a series of smaller appendages, bearing cells extending up to and around the base of the perithece; the appendages simple, rigid, septate; spores as in *Laboulbenia*.

\* L'Agricoltura Ital., xix. (1893) p. 7. See Bot. Centralbl., lv. (1893) p. 279.

† Comptes Rendus, cxvii. (1893) pp. 68-9.

‡ Proc. American Acad. Arts and Sci., xxvii. (1892) pp. 29-45, and xxviii. (1893) pp. 156-88. Cf. this Journal, 1892, p. 82.

*Dimorphomyces*.—Sexual organs borne on separate individuals. Male individual consisting of a series of several superposed cells, the sub-basal one bearing the large cellular long-necked antherid. Female individual consisting of several superposed cells, from the basal of which arise one or several peritheces and simple sterile appendages. Peritheces asymmetrical; spores indistinctly septate.

*Amorphomyces*.—Sexual organs borne on separate individuals. Receptacle of male individual consisting of two superposed cells bearing terminally a single one-celled long-necked antherid. Receptacle of female individual consisting of a few superposed cells, without true appendages, bearing terminally a single large perithece. Asci arising from a lateral placenta-like ascogenous area.

*Haplomyces*.—Receptacle consisting of two small superposed cells, from which arise the single perithece and the single antheridial appendage. Perithece large, pointed, borne on a single pedicel-cell, surmounted by two basal cells. Antheridial appendage consisting of a basal cell surmounted by a terminal body, the antherid, divided by anastomosing septa into numerous small cells, and furnished with a short lateral projection, together with a sub-terminal short spine-like process, arising from a rounded base. Asci four-spored, arising from four main ascogenous centres, each of which is divided into two secondary centres.

*Idiomyces*.—Receptacle short, flattened, terminated on one side by a series of superposed cells, bearing externally a vertical row of closely set appendages, on the opposite side by one or more stalked peritheces, at the base of which on one side arises a second transverse series of similar appendages. Peritheces straight, symmetrical, borne on a pedicel composed of a single basal and several terminal cells. Appendages consisting of a series of antheridial cells, their projecting necks forming a comb-like appendage, which may be terminated by short branches.

*Chaetomyces*.—Receptacle slender, consisting of numerous superposed cells, from which arise successively the appendages and one or more peritheces in a unilateral series. Perithece flattened, the symmetrical apex prominent, borne on two pedicel-cells surmounted by several basal cells. Fertile appendages arising from cells of the receptacle immediately below the perithece; sterile appendages arising from its terminal cells.

*Rhadinomyces*.—Receptacle consisting of two superposed cells, from the upper of which arise one or several stalked peritheces and an antheridial appendage; the appendage consisting of a series of several superposed cells, each of which may bear from its distal end one or more short fertile branches, producing flask-shaped antherids more or less irregularly; the distal cell of the series terminated by one or more long sterile branches. Peritheces sub-conical, borne on a pedicel made up of a single basal cell surmounted by several smaller cells.

*Dichomyces*.—Receptacle flattened, bilaterally symmetrical, multicellular above a narrow pedicel-cell, terminated by two clearly defined transverse rows of cells; the sub-terminal cells of the lower row modified to form, anteriorly, single projecting tooth-like antherids; the upper series bearing a pair of peritheces and several sterile appendages, all symmetrically arranged. Appendages as in *Peyritschia*, simple, cylindrical. Peritheces symmetrical.

*Teratomyces*.—Receptacle consisting of several superposed cells surmounted by a series of smaller cells which surround certain central cells, from which the peritheces arise, and produce distally a circle of appendages, from within which the long-stalked perithece is exerted. Peritheces one or more in number, symmetrical, the pedicel consisting of an elongate basal and three distal cells. Appendages consisting of one or more superposed cells, each producing externally a single row of branches.

Ringworm in Man.\*—M. R. Sabouraud, after a microscopical examination of 100 cases of ringworm, has determined that this disease is caused by two different parasites. The one is characterized by aggregations of small spores,  $3\ \mu$ , and by the absence of mycele, the other by large spores, 7 or  $8\ \mu$ , and the presence of a mycele. The small spores not only fill the hair, but encase it in a sort of sheath; the large spore growth is always inside the hair and does not form an investment. Cultivation experiments confirmed the opinion derived from microscopical examination. The small spore *Tinea* is almost entirely confined to the hair of the scalp. The large spore *Tinea* affects the skin of the body generally and the hair of the beard.

Fungus found in Phthysical Cavities and Sputa.†—Mr. A. C. Jones describes a new fungus which he has often found in the sputum of phthysical persons when the pulmonary tissue is breaking down. The principal features of the fungus are that it overgrows the elastic fibres, around which it is seen as a complete investment formed of little club-shaped elements. These club-shaped elements are also to be seen in rosette-like aggregations, having some resemblance to Actinomyces-grains. From the club-shaped elements there may develop a mycele exhibiting transverse partitions. Another feature is the presence of spicules much like those of barley.

### Protophyta.

#### $\beta$ . Schizomycetes.

Resistance of Bacteria to Pressure combined with a High Temperature.‡—As the result of a series of experiments, Dr. E. v. Freudenreich states that certain bacteria will resist a carbon-dioxide pressure of 80–90 atmospheres, and a pressure of 60 atmospheres in oxygen, combined with an elevation of temperature to about  $65^{\circ}\text{C}$ .

Assimilation of Atmospheric Nitrogen by Microbes.§—M. S. Winogradsky makes a preliminary communication relative to the assimilation of gaseous atmospheric nitrogen by micro-organisms, the first intention of the author being to ascertain if there exist in the soil specific fixative microbes. The procedure adopted was that of methodic cultivation carried out in a medium strictly devoid of nitrogen but containing a fermentable substance, a solution of mineral salts and sugar. The salts were specially prepared, and the dextrose did not contain a

\* Ann. de Micrographie, v. (1893) pp. 329–33.

† Centralbl. f. Bakteriol. u. Parasitenk., xiii. (1893) pp. 697–701 (1 pl.).

‡ SB. Naturf. Gesell. Bern, 1892 (1893) pp. viii.–x.

§ Comptes Rendus, cxvi. (1893) pp. 1385–8. Cf. this Journal, 1893, p. 357.



trace of nitrogen. The cultivations were made in flat-bottomed vessels covered over with bell-jars. The external air reached the cultivations only after it had passed through washing-bottles filled with potash and sulphuric acid. The cultivations were distinguished by specific characters,—the development of gas and the formation of acid, and the presence of zooglyca masses. The acid was chiefly butyric, and the zooglyca masses were formed of and by a large bacillus often containing spores. There were other organisms, but their development was poor, sometimes abnormal; they did not produce either gas or butyric acid. The morphological characters of the bacillus which possesses the property of assimilating free nitrogen are somewhat striking. The young cells are rodlets  $1.2 \mu$  broad and from twice to four times as long. They are motionless, and stain deeply with anilin pigments. Spore-formation is preceded by a general swelling of the cell, which becomes ellipsoidal in shape, and at this period iodine stains the organism black, leaving the two poles uncoloured. Ripening of the spore is indicated by the conversion of the mother-cell into a sort of sac, open or expanded at one end.

**Bacillus mycoides and Nitrification.\***—According to M. E. Marchal the gradual oxidation that takes place in the soil when the nitrogen of organic matter is converted into nitrates (nitrification) is accomplished in three stages:—transformation of organic nitrogen into ammonia; formation of nitrous acid from ammonia; conversion of the nitrites thus formed into nitrates. The first stage is effected by microbial agency, bacteria yeasts and moulds which swarm in the upper layers of the earth. Amongst these, *Bacillus mycoides* (the earth bacillus) possesses not only the widest distribution but the most energetic action; and under its influence oxygen is carried to the elements of albumen, carbon is changed to carbonic acid, sulphur into sulphuric acid, hydrogen partly into water, leaving ammonia as the residue of the oxidation. Small quantities of peptone, leucin, tyrosin, and fatty acids are also produced.

The optimum conditions for this ammonia-making microbe are: a temperature about  $30^{\circ}$ ; perfect aeration; slight alkalinity of the medium; the albuminous solutions must be thin. Besides egg-albumen, the other forms of albumen, and also creatine, leucin, tyrosin, and asparagin are affected in the same way, while urea and nitrate of urea are unaffected. *Bacillus mycoides*, though a former of ammonia and an aerobe in presence of azotized organic matter, has a denitrifying action, and becomes anaerobic when associated with easily reducible bodies (nitrates); and in the absence of free oxygen in solutions containing organic matter (sugar albumen) reduces nitrates to nitrites and ammonia. Hence it has the power of setting free ammonia by two quite opposite processes: by oxidation in one case, by reduction in the other.

**Bactericidal Power of the Blood.†**—Prof. J. Denys and M. A. Kaisin made a series of experiments to test the value of some objections recently raised to the bactericidal property of the blood. These objections were:—(1) The destruction of microbes is due to sudden change of medium. (2) The destruction is proportional to the number of microbes, and this shows that the cause is not to be sought in the blood but in the

\* Bull. R. Acad. Sci. Belg., xxv. (1893) pp. 727-71 (2 figs.).

† La Cellule, ix. (1893) pp. 337-93. Cf. this Journal, 1893, p. 517.



microbes. (3) Destruction is followed by revival, a fact which proves that the microbes have adapted themselves to their new environment. (4) The bactericidal power is not a property peculiar to the blood while in the vessel, but appears only after extravasation. (5) The bactericidal power is not correlated with the animal's resistance; thus rabbit's blood is as bactericidal as dog's blood to anthrax, yet the receptivity is quite different.

In these experiments the authors used *B. coli communis* and *B. anthracis*, and their conclusions are entirely favourable to the view held by Buchner and others that the body-juices play a considerable part in the defence of the organism against infection. They are antiseptic solutions, in fact.

Besides controverting the foregoing objections, two new views on the subject are put forward:—That there is an antagonistic action between the bactericidal substance and the microbic poison; and that there is a reaction of the organism during the infection, even when this is inevitably fatal.

**Acquired Immunity to Pneumococcus.\***—M. B. Issaëff, who has been making some experiments on rabbits with *Pneumococcus*, finds that phagocytosis plays an important part in the preservation of rabbits against this micro-organism. The author's object was apparently to ascertain whether there was any basis for the bactericidal, the attenuation, or the antitoxic theories of immunity to *Pneumococcus*. According to the bactericidal theory the humours (body-juices) and blood-serum of the vaccinated organism prevent the development of the microbes, which perish in the humours. The attenuation theory, while admitting the possibility of microbes developing in a vaccinated organism, asserts that the microbe loses its pathogenic properties owing to the influence of the vaccinated serum, and in this way become harmless to the organism. The antitoxin theory would explain acquired immunity to *Pneumococcus* by the property the serum of vaccinated animals possesses of neutralizing the toxins of *Pneumococcus*. As the experiments showed that these three theories received no support from the facts, the leucocyte is pronounced to play the chief part in this acquired immunity. The general conclusions of the author are that: (1) The toxins of the *Pneumococcus* (Fraenkel) excite a more energetic reaction in rabbits previously vaccinated with this microbe than in the control animals. (2) The blood-serum of rabbits vaccinated against the *Pneumococcus*, though possessing therapeutic properties, is not endowed with any antitoxic power. (3) The serum of vaccinated rabbits does not possess the property of attenuating the virulence of the *Pneumococcus*. (4) The *Pneumococcus* when cultivated in the serum of vaccinated rabbits does not lose the power of producing toxins. (5) The *Pneumococcus* when inoculated on a vaccinated rabbit preserves its pathogenic properties for about 18 hours, and its vitality for about 48 hours after inoculation. (6) In the acquired immunity to *Pneumococcus* phagocytosis plays a most important part.

**Presence of Bacterium coli commune and Bacillus typhosus in Drinking-Water.†**—M. E. Malvoz, who examined the water from

\* Ann. Inst. Pasteur, vii. (1893) pp. 260-79.

† Mém. Soc. d'Hygiène et de Salubrité Pub. de Liège, 1892. See Centralbl. f. Bakteriol. u. Parasitenk., xiv. (1893) p. 69.

twenty-seven houses in which cases of enteric fever had occurred, found *Bacterium coli* thirteen times, the typhoid bacillus five times, and both of them together twice. In seven instances these bacteria were not discovered, though the water contained many germs. In two specimens there were few organisms.

As a rough standard of comparison the author gives the result of an examination of the water of twenty houses in which enteric fever had not occurred. Only a few organisms were found in thirteen instances; in six cases there were many; and once *Bacterium coli*, together with some others, was found.

**Streptococcus longus in Drinking-Water.\***—Dr. Landmann examined water from a well suspected of containing diphtheria bacilli, and found therein a *Streptococcus* fatal to mice. On gelatin plates inoculated with 1, 1/2, 1/4, and 1/8 ccm. of the water, only saprophytes were found, but on agar plates inoculated with the sediment obtained by centrifuging, colonies of streptococci developed. The chain consisted of from three to six cells. Alkaline sugar-bouillon became turbid in 24 hours, and long chains of 100 links or more were formed. 0.3 ccm. of this cultivation killed mice in from 5–8 days, though a minority of the animals survived.

The samples were obtained without previously pumping off the water, and the author advises this procedure in cases of suspected well infection.

**Capsule Bacillus of Ozæna.†**—Sig. Strazza isolated from the secretion on the nasal mucosa of persons suffering from ozæna a capsule bacillus. It develops in the usual media, does not liquefy gelatin, is a facultative anaerobe, immobile, and does not develop at temperatures lower than 10°. If imperfectly stained, a clear space resembling a spore remains in the middle, but this disappears if alkaline methylen-blue or strong aqueous solution of fuchsin be used. The organism is pathogenic to guinea-pigs, which die in from 24–48 hours. Pure cultivations of the bacillus are odourless, but if contaminated with the organisms found in the secretion they do smell.

The author found this bacillus in twenty-five cases of ozæna, usually in conjunction with *Staphylococci* and *Streptococci*.

**Pfeiffer's Influenza Bacillus.‡**—Dr. R. Pfeiffer gives in full an account of his researches on influenza. Considering that it was more probable that the exciting cause would be more easily discovered in the discharge from the lungs than in that from the nasopharyngeal mucosa, cases with copious secretion were selected and the sputum spread out in sterilized glass capsules. Particles indicating the presence of pus were then selected for examination. The best stains were found to be Loeffler's methylen-blue solution and dilute phenol-fuchsin. In the latter, which gave the best results, the preparations were stained for

\* Deutsche Med. Wochenschr., 1893. See Centralbl. f. Bakteriolog. u. Parasitenk., xiv. (1893) p. 431.

† Geneva, 1893. See Centralbl. f. Bakteriolog. u. Parasitenk., xiv. (1893) p. 327.

‡ Zeitschr. f. Hygiene u. Infektionsk., xiii. (1893) pp. 357–85 (8 pls.). See Centralbl. f. Bakteriolog. u. Parasitenk., xiii. (1893) pp. 528–31. Cf. this Journal, 1893, p. 776.

five to ten minutes. The bacilli were found, sometimes as absolutely pure cultivations, chiefly in mucus, but also in the pus-cells. They are not quite so thick as the bacillus of mouse septicæmia, and usually are two to three times as long as they are broad. Occasionally shorter forms, or even quite long filaments are observed. The ends of the rodlets are rounded, and as two not unfrequently lie together they resemble diplococci. They do not possess a capsule; do not show any movements when cultivated in hanging drops, and are decolorized by Gram's method.

Artificial breeding of the bacillus was at first attended with considerable difficulty, and, indeed, there was practically no success until it was discovered that the presence of blood was a necessary adjunct to the cultivation medium, the indispensable constituent being the hæmoglobin. A drop or so of blood, obtained with the usual precautions for preventing its contamination, was placed on an oblique agar surface, and was then inoculated with a trace of influenza sputum. By this method colonies which could be propagated from generation to generation were cultivated in abundance. The colonies of pure cultivations were always of a glass-like transparency; they are strongly aerobic, and the limits of their growth were  $42^{\circ}$  and  $26^{\circ}$ - $27^{\circ}$ . The author was never able to demonstrate the presence of his bacillus in the blood either by microscopical or bacteriological examination.

Numerous infection experiments were made on animals, but no success was obtained, except with monkeys. By injecting these (into the lungs) with 0.5 ccm. of cultivation, a fever lasting some days was set up, and by increasing the dose a toxæmia and death resulted.

The author mentions that he has thrice discovered a bacillus having many features in common with his influenza bacillus, and calls it pseudo-influenza bacillus.

**Water Vibrios and the Ætiology of Cholera.\***—The dogmatic position taken up by Koch and his followers on the ætiology of cholera necessarily implied that if a certain organism is to be regarded as the one and only cause of Asiatic cholera, then this organism would present definite morphological and physiological characters, and would respond to certain tests. These characters and tests were described quite recently,† and the procedure for making a certain and rapid diagnosis of cholera consisted in a microscopical examination of the dejecta; cultivations in pepton solution; on gelatin and agar; the nitro-indol reaction; and experiments on animals. In connection with water vibrios and the ætiology of cholera Dr. J. Sanarelli contests the position of Koch, points out that the microscopical and cultivation appearances have nothing specific about them, and that the nitro-indol test and the pathogenic action on animals are the only characteristics of the cholera vibrio which need discussion.

The author then proceeds to describe some thirty-two vibrios obtained in the city and vicinity of Paris. Nearly all these vibrios were found capable of forming indol, and some of them of giving the cholera-red reaction. With regard to the pathogenic properties of these thirty-two vibrios, only four were found to be extremely pathogenic.

\* Ann. Inst. Pasteur, vii. (1893) pp. 692-735 (2 pls.).

† See this Journal, 1893, p. 552.



After having demonstrated the inexactness of Koch's criteria for the diagnosis of cholera, the author gives the result of his vaccination experiments on guinea-pigs, and sums up in favour of several pathogenic types, and in conclusion makes some remarks on the saprophytic condition of vibrios. The view expressed is that between the vibrios found in cholera dejecta and water vibrios there is a close alliance, and that possibly both may have a common origin. The virulence of vibrios is not retained for any length of time, their pathogenic properties, together with the power of forming indol and of reducing nitrates, passing off as the organism becomes a definite saprophyte.

- BUCHNER, H.—Ueber den Einfluss des Lichtes auf Bakterien und über die Selbstreinigung der Flüsse. (On the Influence of Light on Bacteria, and on the Self purification of Rivers.) *Arch. f. Hygiene*, XVII. (1893) pp. 179-204.
- BURRI, R.—Ueber einige zum Zwecke der Artcharakterisierung anzuwendende Bakteriologische Untersuchungsmethoden nebst Beschreibung von zwei neuen aus Rheinwasser isolierten Bakterien. (On some Bacteriological Investigations undertaken with a view to discover the characteristics of species, with the description of new Bacteria isolated from the water of the Rhine.) *Arch. f. Hygiene*, XIX. (1893) pp. 1-37.
- DUNBAR—Untersuchungen über choleraähnliche Wasserbakterien. (Investigation of Cholera-like Aquatic Bacteria.) *Deutsch. Med. Wochenschr.*, 1893, pp. 799-800.
- GAMALEIA—The Bacterial Poisons. Translated by E. V. Hurd. Detroit, 1893, xiii. and 136 pp.
- GÉRARD, E.—Présence dans le penicillium glaucum d'un ferment agissant comme l'émulsine. (Presence in *P. glaucum* of a Ferment which acts like emulsin.) *Compt. Rend. Soc. Biol.*, 1893, pp. 651-3.
- GOTTSTEIN, A.—Ueber die Zerlegung des Wasserstoffsperoxyds durch die Zellen, mit Bemerkungen über eine makroskopische Reaktion für Bakterien. (On the Destruction of Peroxide of Hydrogen by Cells, with Remarks on a Macroscopic Reaction for Bacteria.) *Arch. f. Pathol. Anat. u. Physiol.*, CXXXIII. (1893) pp. 295-307.
- HESSE, W.—Ueber die gasförmigen Stoffwechselprodukte beim Wachstum der Bakterien. (On the Gaseous Products of Metabolism in the Growth of Bacteria.) *Zeitschr. f. Hygiene*, XV. (1893) pp. 17-37.
- JOHNE—Zur Kenntnis der Morphologie der Milzbrandbacillen. (On the Morphology of Anthrax Bacilli.) *Deutsch. Zeitschr. f. Tiermed.*, XIX. (1893) pp. 244-60.
- KIESSLING, F.—Das *Bacterium coli commune*. Zusammenfassendes Referat. (General Report on *B. coli commune*.) *Hygien. Rundschau*, 1893, pp. 724-43 and 765-91.
- KNORR, R.—Beitrag zur Lehre von der Identität des *Streptococcus pyogenes* und des *Streptococcus erysipelatis*. (On the Identity of *S. pyogenes* and *S. erysipelatis*.) *Berl. Klin. Wochenschr.*, 1893, pp. 699-700.
- MAROT, F.—Un Streptocoque à culture apparente sur pomme de terre. (A *Streptococcus* cultivated on the potato.) *Arch. de Méd. Expér. et d'Anat. Pathol.*, 1893, pp. 548-62.
- PODWYSSOZSKI, W. W.—Zur Morphologie der Choleravibrien. (On the Morphology of Cholera Vibrios.) *Centralbl. f. Allg. Pathol.*, 1893, pp. 673-82.
- RUBNER—*Vibrio Berolinensis*, ein neuer Kommabacillus. (*V. Berolinensis*, a new Comma Bacillus.) *Hygien. Rundschau*, 1893, pp. 717-9.
- SANFELICE, F.—Untersuchungen über anaërobe Mikroorganismen. (Researches on Anaerobic Micro-organisms.) *Zeitschr. f. Hygiene*, XIV. (1893) pp. 339-92.
- STUTZER, A., & O. KNOBLAUCH—Untersuchungen über den Bakteriengehalt des Rheinwassers oberhalb und unterhalb der Stadt Köln. (Investigations on the Bacteria of the Rhine above and below Cologne.) *Festschr. d. Niederrhein. Vereins f. ö. Gesundheitspfl.*, 1893, pp. 95-120.



## MICROSCOPY.

## a. Instruments, Accessories, &amp;c.\*

## (1) Stands.

**Leitz's Microscope.**†—The large Microscope of Leitz, No. 1a, shown in fig. 1 on the next page, can be inclined at any angle; the coarse-adjustment is by rack and pinion, the fine by micrometer screw with divided head; the draw-tube is provided with a millimetre scale; the Abbe condenser, with iris diaphragm, can be raised and lowered by rack and pinion. The ordinary cylinder diaphragm is readily adjusted by simply turning aside the iris diaphragm and slipping out the condenser. The instrument is provided with a triple nose-piece.

**Leitz's New Microscope Stand.**‡—Mr. E. M. Nelson points out that Leitz's new stand is a nearer approach to the "English" model than any Continental instrument hitherto constructed. Instead of the heavy horse-shoe foot, there is a bent claw with a spread of 5 by 6 inches. Mr. Nelson's horse-shoe stage has been adopted, but the spring clips on the sliding bar ought to be removed.

An altogether novel procedure in Microscope construction is to be found in the substage rackwork; the rack is not in the groove, but on one side of it; there is no U-shaped groove at all, but a flat piece of steel which is pressed downwards by a spring; this is tightened up by a screw. Experience alone can decide whether, as seems probable, we have here a very simple and smooth form of slide.

**Microscope for Measurement of Growth of Plants.**§—Herr J. Wiesner describes the apparatus, constructed for him by C. Reichert of Vienna, which he made use of in his experiments on the influence of light on the increase in length of the organs of plants.

The instrument consists of two separable parts, the stand and the body-tube of the Microscope. The stand is composed of a horse-shoe base and a vertical column, which serves to support the body-tube of the Microscope in the horizontal position.

The column has a height of about 119 mm. and can be lengthened by 70 mm. At the back of the movable part of the column is a divided scale, 60 mm. long, which is read off against the vernier attached to the fixed part of the column. The raising of the column, and with it the Microscope, is effected in the usual way by rack and pinion.

The Microscope is connected with the stand by a pin, and is fixed by a screw. The body-tube can be displaced in the horizontal direction by rack and pinion for the purpose of adjusting the object. The whole Microscope can also turn in the horizontal plane about the pin, mentioned above, on the loosening of a screw.

As objective the Reichert system 1a was used. With a tube-length

\* This subdivision contains (1) Stands; (2) Eye-pieces and Objectives; (3) Illuminating and other Apparatus; (4) Photomicrography; (5) Microscopical Optics and Manipulation; (6) Miscellaneous.

† Catalogue No. 34 of Microscopes and Accessory Apparatus. Ernst Leitz, Wetzlar, 1892, p. 19.

‡ Journ. Quekett Micr. Club, v. (1893) pp. 309-11 (3 figs.).

§ Zeitschr. f. wiss. Mikr., x. (1893) pp. 145-8 (1 fig.).

FIG. 1.

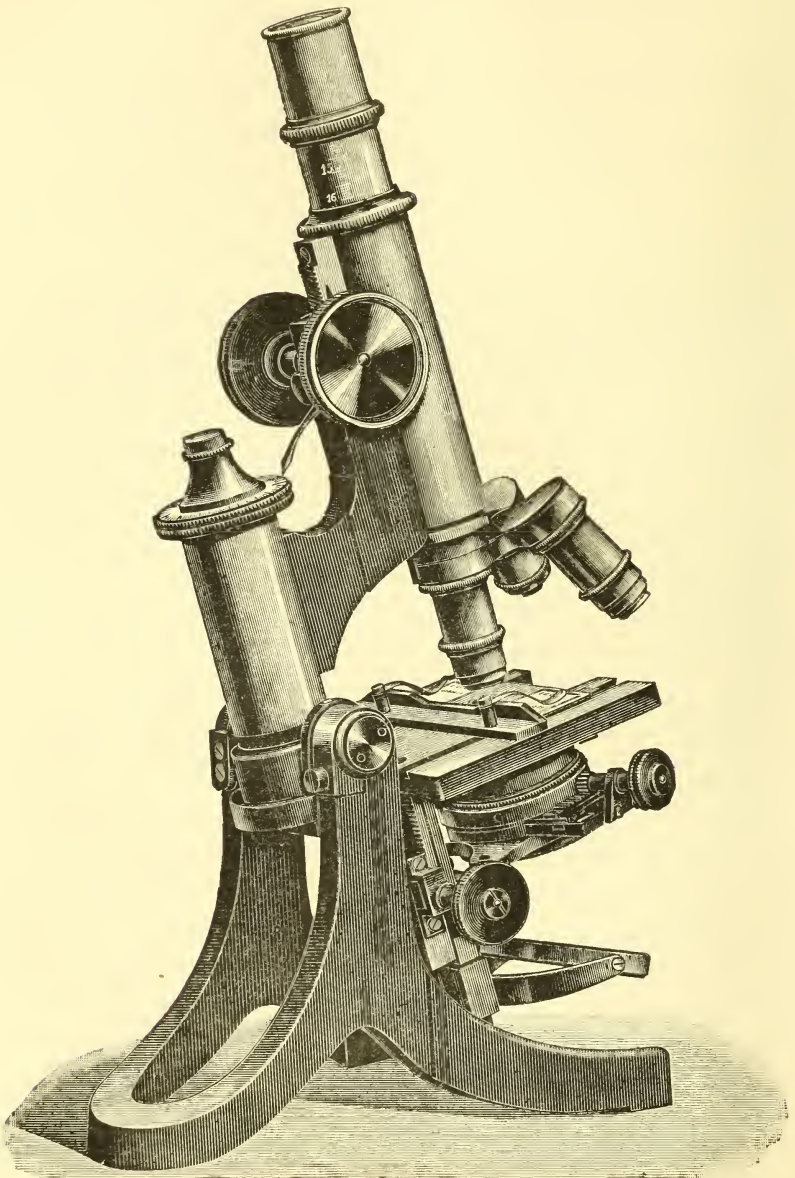

LEITZ'S MICROSCOPE.

of 160 mm. a magnification of twenty times was obtained, for a focal distance of more than 30 mm.

The difference in height of the growing plant can be determined with this instrument in two ways. One method consists in adjusting on a determined fixed point in the Microscope at the beginning and end of the experiment, each time taking the reading on the vernier. This determination is, however, only exact to about 0.1 mm. The more precise method is to take a reading on the micrometer at the beginning and end of the experiment. A difference in height of 0.06 mm. can then be directly determined, and a difference of 0.03 mm. can be conveniently estimated.

**Leitz's Mechanical Stage.\*** — This stage, shown in fig. 2, is adapted to the Leitz stands I, I a, and II. The movement from front to back is effected by two racks and pinions, that from right to left by means of a screw. The movements are measured by two millimetre

FIG. 2.

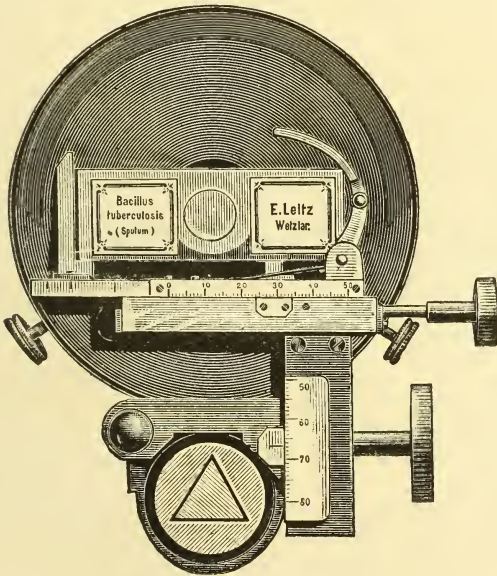

scales. To fit the stage to the Microscope the screw on the right is loosened so that the arc lever can turn about the axis. The stage is then placed on the ordinary Microscope stage, so that the angle-pieces opposite the lever are in contact with the column; the lever is then put in its place and the screw fastened. Lastly, the stage is fixed to the column by means of the other screw.

\* Catalogue No. 34 of Microscopes and Accessory Apparatus. Ernst Leitz, Wetzlar, 1892, p. 45.

**A Farmer's Microscope.**—Mr. E. M. Nelson writes:—"Two or three months ago a scientific farmer asked me if Watson's histological Microscope was suitable for a certain kind of investigation, which he described. To this I replied that in its present condition it was not suitable, but with a few alterations it could be made serviceable for the purposes he had named. He desired me to have these alterations carried out, and, as he gave me a free hand with regard to all the details, the result is the Microscope before you.

Two features are noticeable at once:—(1) There is no fine-adjustment; (2) The main stage is very large for the size of the instrument, viz. 4 by 4 in. The body and the foot are of the usual form, but the principal alterations will be found in the stage.

FIG. 3.

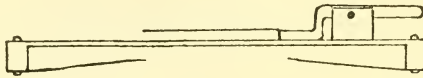
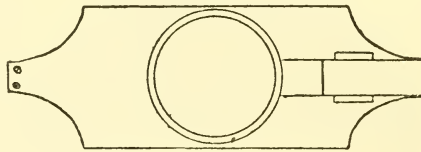

FIG. 4.



The hole in the stage is 1 in. in diameter, and it can be closed by a sliding plate underneath. When it is closed it forms a dark well for the observation of seeds and similar objects under a low power. The stage has two carriers, one of the ordinary sliding type which need not be described. The other, which is much larger, viz.  $6\frac{1}{2}$  by  $2\frac{1}{4}$ , has no aperture in it, but has a ring compressor 2 in. in diameter, which is worked by a lever and spring, precisely like a letter-clip (see figs. 3 and 4, drawn one-third scale). This is for the purpose of holding leaves and similar objects.

The mirror is a silvered equiconvex lens, an invention dating from the last century.

The instrument has, however, another mirror on the same principle for superstage opaque illumination. At the right-hand side underneath the stage is a rotating bar to hold this mirror, which is mounted on a rod. The focus of the mirror is made equal to the distance of the dark well, and in practice its performance will be found most satisfactory. It is  $1\frac{3}{4}$  in. in diam., and concentrates a powerful beam on the object. We have here a cheap and thoroughly practical piece of apparatus, which might with benefit be applied to other instruments. This will be found preferable to the old plan of a bull's-eye placed in front of the stage, where it is always in the way. The mirror being at the back of the stage interferes with stage manipulations no more than the limb of the Microscope.

The lenses selected for use with this instrument also demand notice.



The highest power is a No. 4 Leitz; this has been chosen, not only on account of its being of the power that was required, but also because it makes a very fair low-power lens when the front lenses are removed. The complete lens gives a power of 100 diameters with the tube extended, and 66 with the tube closed; when the front lenses are removed and the tube extended, a power of 32 is obtained. We have, therefore, a range of power from 30 to 100 diameters with the one objective.

The other lens, which Messrs. Watson have constructed at my suggestion, is somewhat of a novelty. It is made on the plan of the Zeiss *a*\* with a concave front, but it differs from those lenses in as much as its aperture is greater and its mount is a rigid one. The range of power in this lens is more than twice as great as in the case of Zeiss *a*\*. For example, on this instrument my Zeiss *a*\* gives a range of power from 6 to 10 diameters, while the new lens on the same instrument gives from 5 to 20 diameters. This lens will be valuable for all kinds of low-power work, as it will do the work which now falls to the 3-, 4-, and 5-in. lenses.

In bringing forward this instrument let me express a hope that it will open a wider field for research and extend the ever-growing popularity of the Microscope.'

### (3) Illuminating and other Apparatus.

**New Exact and Easily Constructed Spherometer.\***—Signor G. Guglielmo has devised a new form of spherometer which can be easily constructed out of ordinary laboratory apparatus without the use of a micrometer screw.

The apparatus is represented in fig. 5. A is a cylindrical or prismatic vessel covered with a glass plate in which two holes are bored. Through one of these holes there passes nearly to the bottom of the vessel the glass or indiarubber tube which is connected with the burette B. Through the other opening projects a glass or metal rod (C or C<sub>1</sub> in the figure) which possesses two points *a* and *b* and slides in the holder D. In order to work the apparatus, a liquid is poured into the cylindrical vessel and into the burette, and the level in A adjusted exactly to the point *b*. The plate, of which the thickness is to be measured, is then placed on the glass plate beneath the point *a*. This will have the effect of raising *b* above the surface of the liquid. More liquid is then introduced from the burette until the level in the vessel is again flush with *b*. The

FIG. 5.

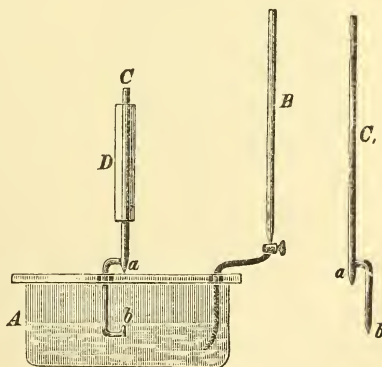

\* Atti d. R. Acc. d. Lincei. Rndct. (1893) I. 4. See Zeitschr. f. Instrumentenk., xiii. (1893) p. 393.

quotient of the liquid used (as measured by the burette) by the area of the cylindrical vessel gives the thickness required. If an arrangement be attached to the burette by which the liquid can be drawn back into it, a great number of adjustments may be made for the same determination. Mercury is the best liquid to use, and in this case a rod of the form  $C_1$  is employed, but in the case of water, one of the form  $C$ . The exactness of the determination naturally depends on the correct adjustment of this rod; it must stand vertically and must not rotate during a determination; the glass plate also on which the point  $a$  rests must be exactly plane and horizontal. According to the author, when these conditions are fulfilled the new spherometer is in no way inferior in exactness to the ordinary instrument with micrometer screw. By a number of adjustments of the same level an exactness up to 0.001 mm. was effected.

**Chimney for a Microscope Lamp.**—Mr. Nelson writes:—"This chimney, which Messrs. Watson have made from my designs, would at first sight appear to be an elaboration of the existing illuminating apparatus for a Microscope, whereas it is an attempt at simplification.

While working with the superstage illuminator of the "Farmer's" Microscope, it occurred to me that an equiconvex lens silvered mirror would form an excellent parallelizer for a Microscope lamp.

A reflector to parallelize a wide-angled beam can be constructed on that principle with shallow curves, it is therefore apparent that the aberrations will be less than that of a single plano-convex lens,\* whose ratio of aperture to focus is the same.

FIG. 6.

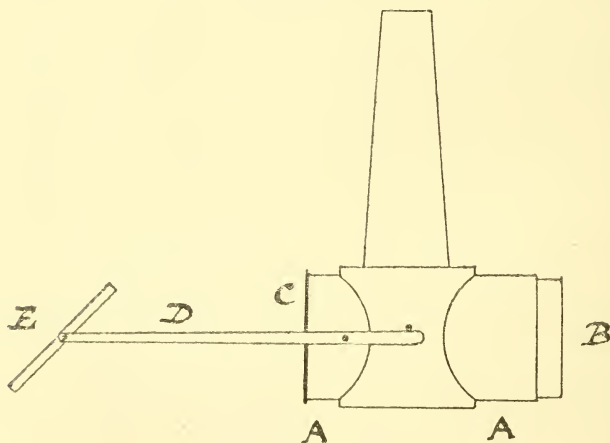

The adaptation of such a mirror to the chimney itself was only one step further. The chimney, fig. 6, is the same as my ordinary one with a horizontal tube AA inserted, which is of course cut away inside the

\* Calculation shows that it is less than a half.

flame chamber; at the back another short tube B slides easily, one end of this inner tube carries the equiconvex lens mirror, while the other is closed and made dead black.

When parallel rays are wanted the mirror is inserted, and the tube pushed home, as in fig. 6, as far as it will go, it will then be found to be centered and focused to the flame. This plan saves all trouble of adjustment.

The front C is a circular piece of plane glass, fitted to a small piece of tube, which slides into A. Fastened to each side of the lamp are two aluminium arms D, which carry at their extremities a plane mirror E. This will be found convenient, not only for the illumination of small Microscopes when used in an inclined position, because the light can be reflected downwards on to the mirror of the Microscope, but also for dissection, opaque illumination, &c.

When divergent rays from the edge of the flame are required for direct illumination in the ordinary manner, the arms D with the attached mirror E are turned upwards, the tube B is withdrawn, and replaced with the dead black surface inwards, the mirror being then outside. The sliding-tube C with the plane glass can be withdrawn, and a plate having the usual  $1\frac{1}{2}$  by  $\frac{3}{4}$  rectangular opening, closed by a 3 by 1 slip, inserted in its place; some observers preferring all extraneous light cut out."

**Leitz's Micrometer Screw Adjustment.\***—This micrometer screw, which is shown in section in fig. 7, is constructed with particular attention to the elimination of all lateral motion. The spindle is hollow and contains a freely movable steel cylinder, the point of which transmits the pressure to the spring. The micrometer thread is carefully cut so that the screw works freely in either direction, and stops in any position without slipping.

#### (4) Photomicrography.

**Leitz's Photomicrographic Apparatus.†**—In this instrument, represented in fig. 8, the camera is supported by a metal column which rises from a broad iron base on which the Microscope stands. This column is adjustable in height and can be fixed in any position by thumb-screws, so that the apparatus can be used with Microscopes of various sizes. The neck of the camera admits diaphragms of various

FIG. 7.

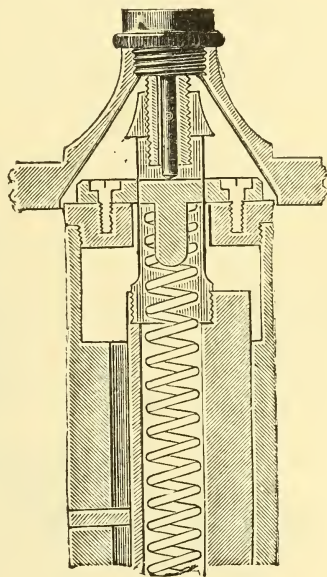

\* Catalogue No. 34 of Microscopes and Accessory Apparatus. Ernst Leitz, Wetzlar, 1892, p. 12.

† Op. cit., p. 44.

sizes, by which the size of the picture may be regulated. Accurate focusing is effected by means of a simple lens which moves over the

FIG. 8.

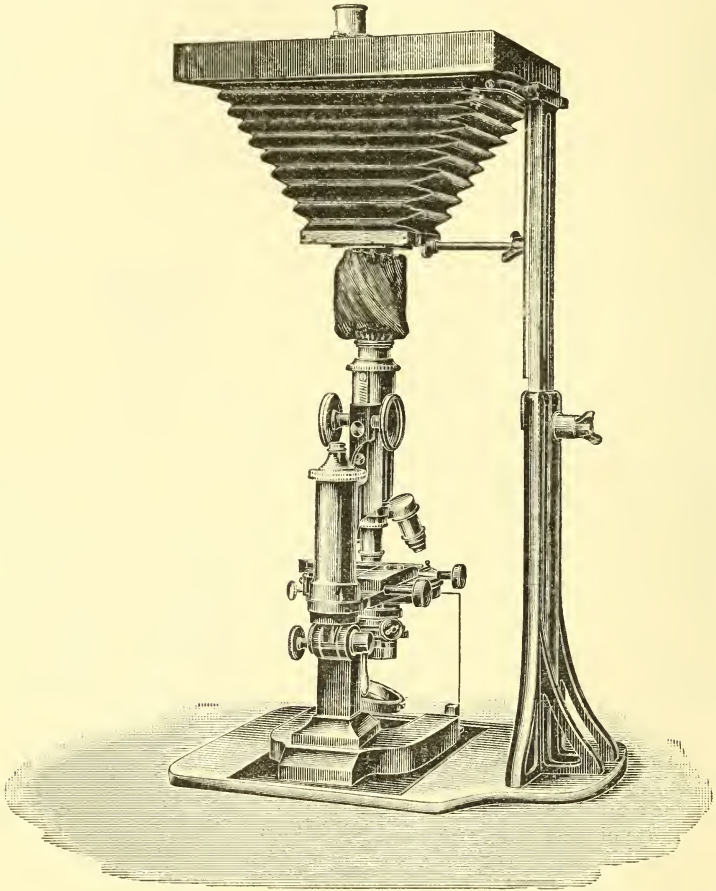

image-plate. The plate-holders are made for plates of the sizes, 9 by 12 cm. ( $3\frac{1}{2}$  by  $4\frac{3}{4}$  in.) and 13 by 18 cm. (5 by 7 in.).

**On Instantaneous Photomicrography.\***—Herr G. Marktanner-Turnercscher remarks that three methods of making instantaneous photographs of microscopic objects have been proposed besides the primitive process of simply placing an instantaneous shutter between the source of light and the object.

In the first method, which requires the most intense illumination, the light from the object is reflected by a suitable arrangement of prisms

\* American Annual of Photography, 1894, pp. 245-8 (1 fig.).



into a side tube through which the living object is observed. At the moment selected for the exposure, the prism is rapidly pushed aside, its motion being followed by a slit cut into the movable portion of the shutter attached to the objective, so that the plate enclosed in the camera is illuminated for an instant.

The disadvantages of the method are the blinding of the eyes by the intense light when watching for the most favourable moment for exposure, and the continuous exposure of the object to light and injurious heat rays.

The second method consists in the employment of a source of light which flashes up instantaneously. For this purpose magnesium powder is used; but the method is improved by adding to the powder substances which render the flame greenish-yellow, so that photographs can be obtained with but imperfectly corrected lenses. The objection to this method is the impossibility of selecting the moment of exposure.

The third method, designed by the author in order to obviate the difficulties in the preceding methods, is necessarily more complicated and consists of two principal parts. The first part is represented by a slide shutter interposed between the source of light and object and showing successively:—

(1) A circular opening covered with coloured glass or gelatin, by which the light and heat rays can be reduced as much as is desired.

(2) A rectangular slit which makes the exposure by sliding forward.

(3) A non-perforated portion of the shutter which excludes all light after the exposure is made.

The second part of the apparatus consists of another slide carrying a reflecting prism by which the light is thrown into a side tube. When the slide is released the prism is rapidly pushed aside, and passage is opened for the light to the main tube. Both shutters must be pneumatically released at exactly the same time. The prism-carriage, which is

FIG. 9.

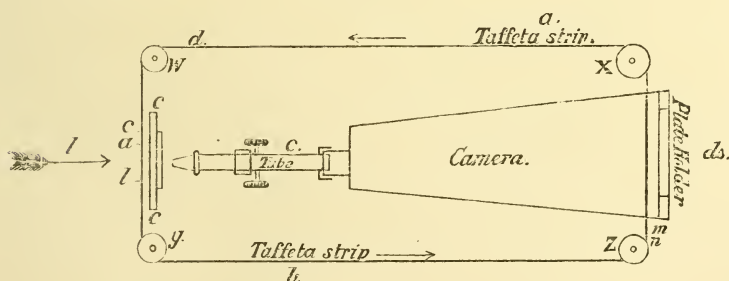

best fastened directly behind the objective, then moves rapidly aside, opening a path for the light rays to the sensitive plate; the slit of the first slide passes across and the exposure is made.

The only difficulty which can occur in this method is insufficient rapidity of the two shutters.

The author makes an improvement on the ordinary Anschuetz

shutter by passing the strip of taffeta, as seen in fig. 9, over four rollers in such a way that a circular aperture cut in one end of the taffeta passes directly in front of the plate at exactly the same time that a rectangular opening cut in the other end of the taffeta passes between the source of light and the object. The prism arrangement remains the same as above described, and must be released by a device similar to the mechanism by which the propelling of the taffeta strip is effected.

In fig. 9 *m n* represents the slit for exposure, *ab* the circular aperture covered with a red gelatin pellicle, *cd* the rectangular aperture, allowing light to enter during exposure, *w, x, y, z*, the rollers upon which the taffeta strips are propelled.

**On the Cooling of Projection Preparations.\***—Dr. O. Zoth points out the difficulties attending projection by means of very intense sources of light, when the object is sensitive to a rise in temperature, as in the case of living animals or plants. The usual method for absorbing the heat rays consists in the use of troughs of water and concentrated solutions of alum, or of plates of alum. The author gives the following table showing the effect of different thicknesses of water in the absorption of the heat rays in the case of the Locatelli lamp :

Layer of water in mm.	Percentage of heat-rays transmitted.
1	.. 19.3
5	.. 9.1
10	.. 7.7
50	.. 2.4
100	.. 1.3
150	.. 0.7
200	.. 0.7

The table shows that no very great advantage is obtained by increasing the thickness of water beyond 50 mm.

The best and simplest heat-absorption apparatus consists of a trough about 5 cm. thick, which is filled with distilled water and placed in the path of the illuminating pencil. An experiment made in order to test the utility of such an absorption-cooler showed, in the case of a Duboscq projection lantern, that whereas the rise in temperature without the absorption apparatus was as much as 35° within two minutes, after the cooler had been introduced the rise in five minutes only amounted to 10° and the temperature then remained constant at 30° to 35°. The absorption-cooler, however, does not suffice for all cases; even preparations mounted in resin which are to be observed under very high powers begin to shrink, and the resin softens as soon as the focus of the Abbe illuminating apparatus is brought near to the preparation. For such cases, therefore, the author recommends, besides the cooling by absorption of the heat rays, the direct cooling of the preparation by conduction.

The apparatus which he has designed for this purpose consists, as seen in fig. 10, of a brass plate 6.25 mm. thick, 70 mm. long, and 40 mm. broad, in the middle of which is bored a circular hole of 18 mm.

\* Zeitschr. f. wiss. Mikr., x. (1893) pp. 152-6 (1 fig.).

diameter which is closed on both sides by round cover-glasses 21 mm. in diameter. The latter are let into the plate so that their upper surfaces are exactly in the same plane as the surfaces of the plate. The two borings made in the side of the plate at *a* and *b* communicate, as seen in the figure, with the cylindrical space enclosed between the cover-glasses. The object-holder is fastened to the cooler by means of the two clamps *f*, and the whole apparatus is set in a movable object-slide. The cooling is effected by a stream of cold water which enters by the pipe at *a*, and is carried off at *b*. Experiments made as before to determine the effect of the cooler showed that, when both coolers were used, in five minutes the temperature only rose  $1^{\circ}\cdot5$ , from  $25^{\circ}$  to  $26^{\circ}\cdot5$ , and then remained constant at  $26^{\circ}$  to  $27^{\circ}$ . In these experiments the thermometer was mounted in a mercury trough, 5 mm. thick, the sides of which were thickly coated with lamp-black.

FIG. 10.

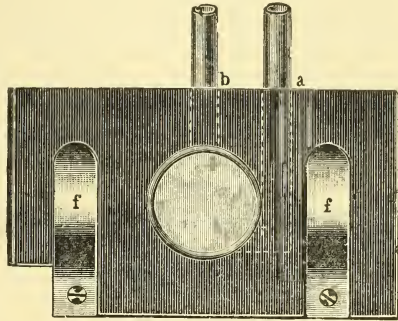

The cooler has the disadvantage that it limits the use of the ordinary Abbe condenser since it is impossible, owing to the thickness of the cooler (6·25 mm.), to adjust the focus in parallel light on the plane of the object or near it. A special condenser, however, of greater focal length can be used, since for projection purposes an aperture higher than 1·0 is not required.

**Orthochromatism applied to Photomicrography.\*** — Before the Société Française de Photographie on May 5th, M. Monpillard read a paper on this subject, in the course of which he said that the design of photomicrography is, given an object visible to the naked eye, to obtain an enlarged image of it, scrupulously accurate both in form and detail. Nothing is more easy in the case of colourless objects, such as diatoms, sections of bones, &c., the great perfection of modern objectives permitting of the obtainment of great sharpness and detail of image. It is not equally so when the objects are coloured, either naturally or artificially, and it may be said—for experience has proved it to be so—that all coloration degrades the perfection of the photographic image, obtained with ordinary gelatin plates, so that if the object be of blue or violet colour (the most actinic colours), it stands out badly from the ground, and has its details poorly rendered. On the other hand, if it is yellow, orange, or red, the object is vigorously rendered on the ground, but the details, bathed, as it were, in a light that is powerless to affect the sensitive salt, will, if the object be green, be very small, and less so with yellow and red.

In all cases, the employment of orthochromatic plates requires also the use of coloured screens.

\* Anthony's Photographic Bulletin, xxiv. (1893) pp. 608-11.

*Orthochromatic Sensitiveness.*—Though commercial orthochromatic plates are sensitive for the green and red, and generally give satisfaction, M. Monpillard says that, for scientific purposes, he prefers ready orthochromatized plates, which, when used shortly after preparation, have a maximum of sensitiveness to the luminous radiations. The operation of orthochromatization demands only elementary care. The dark-room lamp should have two thicknesses of deep ruby glass, the flame being reduced to as small a degree as convenient during the bathing of the plates. After the plates are bathed they are passed through three dishes of distilled water, and are finally dried in a drying cupboard containing a vessel in which calcium chloride is placed.

For photomicrographic purposes the following colours give the best results:—(1) Erythrosin (for green-yellow, yellow, and yellow-orange); (2) Cyanine (for red-orange and red).

M. Monpillard says the following formulas have given him satisfaction:—

Erythrosine (stock solution):—Erythrosine 1 part; distilled water 1000 parts.

Sensitizing bath:—Stock solution of erythrosine 4 ccm.; water 100 ccm.; ammonia, 0.5 ccm.

Cyanine (stock solution):—Cyanine 0.1 part; alcohol (95 per cent.) 100 parts. Only a small quantity of the solution should be prepared and it should be kept in the dark.

Sensitizing bath:—Stock solution of cyanine 4 ccm.; water 100 ccm.; alcohol (95 per cent.) 5 ccm.; ammonia 1.5 ccm. The plates are immersed in either of the foregoing baths for two minutes, and are then washed and dried as directed.

Erythrosine and cyanine plates bathed in both erythrosine and cyanine are rendered sensitive to yellow and red. The first bath consists of:—Stock solution of erythrosine 20 ccm.; distilled water 80 ccm. After two minutes' immersion the plates are washed in two waters, and are then bathed in the cyanine solution given, washed and dried.

Plates so treated are, it is pointed out, very much slower, but this is no disadvantage in photomicrography, and, on the other hand, they do not fog in development, which frequently happens when, to raise their general sensitiveness, the orthochromatizing bath is preceded by an alkaline bath.

*Coloured Screens.*—Coloured screens may be used either in the form of stained collodion, or, preferably, a small glass trough with parallel faces may be fitted with either of the following solutions:—

(1) For light-yellow screen:—Neutral chromate of potash 1 gram.; water 100 parts.

(2) For deep-yellow screen:—Neutral chromate of potash 5 gram.; water 100 parts.

(3) For orange screen:—Bichromate of potash 8 gram.; water 100 parts.

(4) For red screen:—Erythrosine 0.2 gram.; water 100 parts.

No. 1 weakens the blues and yellows; No. 2 extinguishes them; No. 3 cuts off the blue; No. 4 accentuates the action of the red.

With those coloured screens, and having sensitized the plates for given colours, it will be easy to obtain in their true values reproductions



of objects coloured or uncoloured. It is necessary, however, that the focus and the exposure should be made in the same monochromatic light, corresponding to a determined spectrum colour; this method of working assures the perfect sharpness of the image, inasmuch as the chemical focus is corrected. For this reason it is desirable to avoid, in exposing on one object, the use of screens of two different colours, except in the case where, on account of the presence of a deep red, it would be useful to prolong the exposure. The plates, after treatment with erythrosine and cyanine, being sensitive to the red and blue it is indispensable, to give the image its maximum of effect, to illuminate the object with a yellow or orange light, arresting or moderating the action of the actinic rays, and leaving free to pass the radiations corresponding to the colour of the object, if that is green, yellow, orange, or red.

The following table will give an idea of the employment of coloured screens with plates sensitized with cyanine and erythrosine:—

*Object in Monochrome—Actinic Rays.*

Colour.	Sensitizer.	Screen.
Blues or violets {deep } ..	Erythrosine .. .. .	{Pale yellow.
{pale } ..		{Deep yellow or orange.

*Chemical Rays.*

Greens .. .. .	} Erythrosine .. .. .	Deep yellow or orange.
Yellows .. .. .		
Yellow-orange .. .. .		
Orange-red .. .. .	} Cyanine .. .. .	{Deep yellow or orange.
Red .. .. .		
Deep red .. .. .		

*Coloured Objects—Non-Actinic Colours.*

Green and yellow .. .. .	Erythrosine .. .. .	Deep yellow.
Green and red .. .. .	} Erythrosine .. .. .	{Deep yellow or orange, then red.
Yellow and red .. .. .		
Green and red .. .. .	} Erythrosine and cyanine	Deep yellow or orange.
Yellow and red .. .. .		

*Actinic Colours in the Presence of Non-Actinic Colours.*

Blue or violet with yellow.	Erythrosine .. .. .	Light or deep yellow, or orange, according to the intensity of the blue or violet.
Blue or violet with red ..	Cyanine .. .. .	Same screens; in case red is very deep continue the exposure with a red screen.

At first sight it might seem abnormal to attempt to photograph an object of a blue or violet colour with an emulsion sensitized for yellow, but M. Monpillard says nothing is more rational. It will suffice to obtain an image showing vigorously, with the shadows and half tones well rendered. Now, with an emulsion which is particularly sensitive to the blue and violet, the object in question will appear so luminous that the ground will be slightly lost, and the half tones will not come up well. The interposition of a yellow or orange screen will retard the

luminous impression, by neutralizing the rays emanating from the blue or violet parts of the object; but the emulsion not being sensitive to the yellow, a general cutting off will result, both for the ground as well as for the object, and the image will not have gained. Retaining the same screen and substituting for the ordinary plate a plate sensitized for the yellow, the ground will be forcibly rendered, while the blues and the violets, partly reduced by the coloured screen, will act with less rapidity, and will be rendered on the plate in their proper value. In a word, the plate sensitized for the yellow will reproduce the object as if it were grey and black on a white ground.

Where an object combines red and yellow colours it would be possible, at a push, to obtain a true rendering with a plate sensitized for yellow by commencing the exposure with a yellow screen, and continuing for the red with a screen equally red; although, for the reasons already given, the substitution of one screen for the other would endanger the sharpness of the image. It would be better to sensitize for red and yellow and, according to the intensity of the former, expose with a deep yellow or orange screen. If blues and violets are found in the presence of yellows, oranges, or reds, it would suffice to use a plate sensitized for the least actinic colour (yellow or red), and as the plate is, of course, sensitive to the blues and violets, a yellow screen, pale or deep, could be used according as the more actinic parts of the object are more or less coloured.

For development the author recommends hydroquinone with an alkaline carbonate and bromide, and the use of a feeble light in the dark room.

#### (5) Microscopical Optics and Manipulation.

**Chromatic Aberration of Lenses.\***—Prof. L. Weber gives the following practical method of demonstrating in the simplest way from the law of refraction the chromatic aberration of a lens:—

The aperture of a simple, moderately large lens  $LL$  (fig. 11) is covered with an opaque screen  $SS$ , in which two small holes  $oo$ , 1–2 mm. in diameter, are bored near the rim of the lens on the horizontal middle line. If a point of light be then brought into the focus  $F$  of the lens, the rays proceeding from the holes  $oo$  will be parallel. The eye at a distance of 10 to 20 m. from the lens, looking along  $r$ , will then see one of the holes in the screen as a bright point of light, and in order to see the other hole will have to be displaced through a distance equal to the distance between the holes. If the distance be exactly equal to the distance between the pupils of the two eyes, the two holes will be seen simultaneously by both eyes. The smallest movement of the head will then cause the two points of light to appear unequally bright.

The difficulty of getting a point of light, such as a needle-hole in a screen in front of a lamp, in the focus of the lens may be obviated by the use of a vertical slit about  $1/2$  mm. broad.

The above observations will only be rigidly exact provided that monochromatic light (e. g. soda light) is used, and that the slit is exactly in the focus of the lens which corresponds to this particular colour.

The observation will be quite different if the slit is illuminated

\* Central-Ztg. f. Optik u. Mechanik, xiv. (1893) pp. 241–2.

by light of all colours, e. g. by ordinary lamp-light, since the lens has a special focus for each special colour. If the slit is exactly in the focus of the red light, only the red rays through the two holes will be parallel, while the rays of other colours will converge.

The consequence of this is that the two holes in the screen will be seen as two stars shining in spectral colours. The eye in moving in the direction *abcd* will first see a red star and then successively an orange, yellow, green, blue, indigo and violet one. From *b* to *c* there will be a short extinction of the light; then the second hole will come into view and will appear at first violet, and then the other colours in inverse order. By simultaneous observation with both eyes, in the direction *rr*, two equally bright red stars will be seen. The focus belonging to the red rays lies farthest from the lens. If, therefore, the slit be brought a little nearer the lens, the red colour of the two stars will change to orange.

Since for this observation with both eyes the distance of the holes in the screen must be equal to the distance between the pupils, two observers with different pupil-distances will, under otherwise the same conditions, see different colours.

If the slit is moved farther from the lens than the focus of the red rays, then all the rays converge, but the point of intersection of the red rays lies farthest from that of the violet nearest to the lens. This point of intersection is easily found by observing with one eye and finding the point where both stars appear equally bright and equally coloured.

The spherical aberration may also be demonstrated by the same method. For this purpose, beside the first pair of holes, a second pair may be bored nearer to the centre. The marginal rays in all colours will then be found to converge nearer to the lens than those nearer the centre.

FIG. 11.

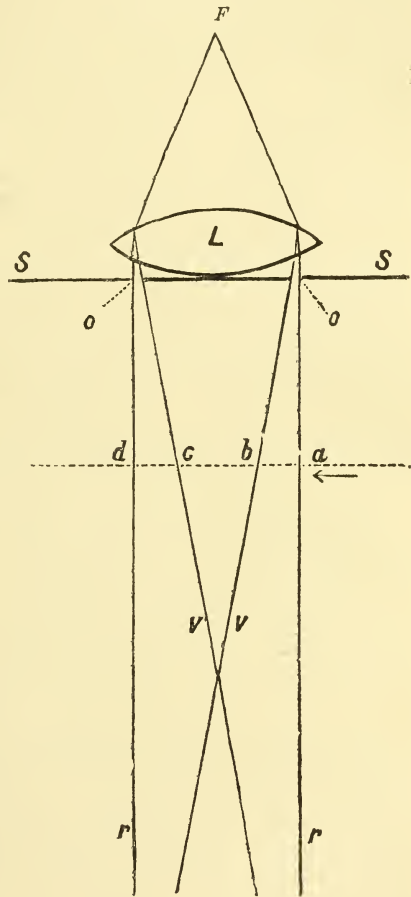

## (6) Miscellaneous.

The late Dr. Kützing.—Trangott Friedrich Kützing, the Nestor of European algologists, died at Nordhausen on the 7th of September, 1893, in the eighty-seventh year of his age. Kützing had withdrawn for so many years from practical scientific work and from scientific literature, that he belongs altogether to a past generation. He was one of the first to place the study of Algæ, and especially of seaweeds, on a scientific foundation. As a describer and delineator he was almost unrivalled, and a very large number of his genera and species still hold their place in all works on algology. His 'Phycologia Generalis,' published in 1843, his 'Tabulæ Phycologicæ,' issued in 20 volumes between 1845 and 1870, with 2000 illustrations which are still of the greatest use to all workers on the lower forms of vegetable life, and his 'Species Algarum,' published in 1849, were among the first general systematic works on Algæ in which modern principles of classification were employed. This was a period of great activity in algology. Nearly contemporaneously with these classical works appeared also Harvey's 'Phycologia Britannica' (1846-1851), Hassall's 'British Freshwater Algæ' (1845), Nägeli's 'Die neuern Algensysteme' (1847), and Agardh's 'Species, genera, et ordines Algarum' (1848-1880). Even before that time Kützing had published (in 1841) his 'Umwandlung niederen Algenformen in höhere'; and in 1844 appeared his 'Die kiesel-schalige Bacillarien oder Diatomeen,' the first important work on the structure of diatoms. The first discovery of the siliceous nature of the shell of the diatom is due to Kützing rather than to Ehrenberg. Since 1870 nothing has appeared from his pen. Kützing's extensive type-collection of Algæ is at the University of Leyden.

Prof. A. Milnes Marshall.—We have to express our sympathy with the Manchester Microscopical Society in the sudden death of their President, who, as the daily papers will have informed our readers, met with a fatal accident on Scawfell on December 31st last. But it is not only the Manchester Microscopical Society, nor Owens College, which has lost one of the most distinguished of its Professors, that has to lament his loss. He was in the van of morphological science in this country, and his text-books on the 'Frog,' on 'Practical Zoology,' and on 'Embryology' have taken the first place among the handbooks for the biological student. He was associated with the late Prof. Balfour in the early stages of the formation of the now famous School of Morphology at Cambridge, and as Professor in Manchester he was the teacher of several morphologists who have already distinguished themselves. His early death at the age of 41 calls to mind that of A. H. Garrod and of W. A. Forbes, like himself Fellows of St. John's College, Cambridge, and adds another to the many severe losses which morphology has suffered in this country during the last fifteen years. Lately he assisted in the editorship of our valued contemporary the 'Quarterly Journal of Microscopical Science.'

Prof. P. J. Van Beneden.—The Society has lost, by the death of Prof. Van Beneden, on the 8th of January last, one of the most venerable and distinguished of its Honorary Fellows. Somewhat younger than Owen, for he had only just entered his eighty-fifth year, P. J. Van



Beneden was the oldest of Belgian zoologists, and one of that band of pioneers of whom Svén Lovén is alone now left to us. It is to him that we owe much of what is now elementary knowledge with regard to the wonderful "alternations of generations" exhibited by the Hydroid Polyps, and the history of the changes undergone by tapeworms in their different hosts. He was devoted to the study of parasitic Crustacea, and he was the first to show that *Pentastomum* is a modified and degraded Arachnid. So far we have spoken of his work as a student with the Microscope, but it is not to be forgotten how largely he added to our knowledge of the hugest of living creatures—the Octacea, and the admirable use to which he put the opportunities afforded him to study the fossil Whales, of which the deposits near Antwerp are so full.

**The Measurement of Light and Colour Sensations.\***—Mr. E. M. Nelson writes:—Mr. J. W. Lovibond in 'Measurement of Light and Colour Sensations,' deals with an instrument invented and called by him a "Tintometer." Before describing this instrument, it is important to bear in mind that the ground traversed is in the main psychological rather than physical, because it is light and colour as appreciated by the human eye, that are only taken account of. If, for instance, we look at monochromatic light of wave-length  $\cdot 52 \mu$ , we should call it green, and would be unable to distinguish it from light passed through a piece of green glass. But if we examine by a spectroscope the light transmitted through the green glass we shall find it composed of blue as well as of green light. Thus while there exists an essential difference between the two greens the unassisted eye is wholly unable to recognize it.

It would seem, therefore, that all measurements of light and colour, which depend solely for their appreciation on the human eye, must be valueless. In other words, such measurements in order to be trustworthy must be on a physical, and not on a psychological basis.

That this, however, is only a shallow view of the question is amply proved in this work, for by means of the "tintometer" minute differences of colour may be perceived and measured, which are quite beyond the range of the spectroscope. To adequately describe the "tintometer" and its applications would exceed the limit of this note, because intricate and complex combinations arise before one has proceeded very far, but an elementary idea of the principle which underlies its construction can be conveyed in a brief description.

Pure white diffused daylight, such as that observed in a sea mist, can be totally absorbed by passing it through certain thicknesses of red, yellow, and blue glass. These red, yellow, and blue glasses are divided into arbitrary units, so that an equal number of red, yellow, and blue units always yield a neutral tint of a certain depth.

Although the units are arbitrary they are *uniform* and *recoverable* if lost; thus they in no wise differ from ordinary measures of length, weight, and capacity. The limit of perception is  $\cdot 006$  of a unit. The mechanism of the instrument is very simple. A tube is longitudinally divided into two halves, through one half the object to be tested is viewed, and its colour is matched in the other half by the insertion of the requisite number of red, yellow, and blue units.

\* 'Measurement of Light and Colour Sensations,' London, 8vo, 1893, 132 pp., 12 pls. and 13 figs.

The simplest example is that of "carmine," which is exactly balanced by 38 units of red.

"French mauve" is balanced by 8.4 units of red, .6 units of yellow, and 6.8 units of blue. Here we have .6 units common to the three colours, therefore we find as a first result .6 neutral tint units, viz. .6 units of black. We have left  $8.4 - .6 = 7.8$  units of red, and  $6.8 - .6 = 6.2$  units of blue; but as red and blue form violet, 6.2 units of violet may be taken out of the 7.8 units of red and the 6.2 units of blue, leaving as a remainder 1.6 units of red. The total result is, therefore, 6.2 violet + 1.6 red + .6 black.

Another comparison result is of interest. "Ivory-black" is balanced by 10.6 units of red, 9.2 of yellow, and 11.0 of blue. Proceeding as in the former case, we obtain 9.2 units of black, 1.4 of violet, and .4 of blue. "Lamp-black," however, gives 9.2 units of black, 1.4 of violet, and 1.9 of blue. There is, therefore, a difference between "ivory-black" and "lamp-black" amounting to 1.5 units of blue. The recognition and measurement of such a difference would not be possible with a spectroscope. The economic value of this instrument is great; for example, the price of flour, which is dependent on its colour, can be indisputably fixed by the "tintometer"; and the percentage of carbon in steel can be determined by inspection, without the trouble of a difficult chemical analysis.

Perhaps microscopists will be more interested in the values obtained from drinking water. A thickness of two feet from a chalk well gave .14 green, .24 blue; when filtered it gave .29 green, .05 yellow; when distilled .37 green, .15 yellow; but after aeration with  $\text{CO}_2$  it gave .16 green, .24 blue. The restoration of the blue by means of aeration is an interesting result.

A thickness of 2 feet of river water, taken above a sewage outfall, gave .5 green, .7 blue; but two inches of the same river, taken below the sewage outfall, gave 1.9 black, 1.4 yellow; this when filtered gave .44 green, .86 yellow.

After such examples it will be needless to call attention to the scientific value of the "tintometer," which is so thoroughly and clearly explained in Mr. Lovibond's book.

**Patents for Inventions.**—The Comptroller-General of Patents, Designs, and Trade Marks has submitted to us a volume dealing with "abridgments of specifications" of Class 97, Philosophical Instruments,\* for the years 1877-83. A glance through it is sufficient to show that it will be of much value to the microscopist whose experience leads him to suggest what he thinks to be an improvement in our favourite instrument.

#### B. Technique.†

**Microtometist's Vade-Mecum.‡**—Mr. A. Bolles Lee is to be congratulated on the appearance of the third edition of his now well-

\* London, 1893, sold at the Patent Office Sale Branch, 105 pp., with figs. in text.

† This subdivision contains (1) Collecting Objects, including Culture Processes; (2) Preparing Objects; (3) Cutting, including Imbedding and Microtomes; (4) Staining and Injecting; (5) Mounting, including slides, preservative fluids, &c.; (6) Miscellaneous.

‡ London, 8vo, 1893, viii. and 509 pp.

known handbook, which is a distinct advance on the two earlier editions. His knowledge and experience fully entitle him to select the methods which he thinks should be recommended to the worker, and to bury in the cold shade of absence from his book those that have been superseded or have not stood the test of work. It is difficult to select where so much is admirable, but we think the severest critic will be satisfied with the paragraph on methyl-green or those on carmine staining. The chapter on Hæmatein and other organic stains must be studied by every microscopist. But it is not only he who makes microscopical preparations that should obtain this book, it has many useful hints for the dissector of animals or the preparer of parts or specimens for museums.

The microscopist who is unacquainted with the German tongue—and we fear there are still one or two left in out-of-the-way villages—will be misled by the term “juice of fruits” in par. 358; retranslation into German shows, however, that liquor amnii is meant. The author informs us that there is an error in par. 151, where 1 per cent. salicylic acid should read 0·1 and 5 per cent. salicylate 0·5; those who use the book must note this correction.

NABIAS, B. DE, & J. SABRAZÈS—*Remarques sur quelques points de technique histologique et bactériologique.* (Remarks on several points of Histological and Bacteriological Technique.) *Arch. Clin. de Bordeaux*, 1893, pp. 165-72.

(1) Collecting Objects, including Culture Processes.

**Stage-Aquarium.\***—Dr. C. J. Cori has made some improvements in the stage-aquarium described by him in ‘Lotos,’ xiii. (1893). The apparatus there described consisted of an object-holder, 5 by 10 cm. in size,

FIG. 12.

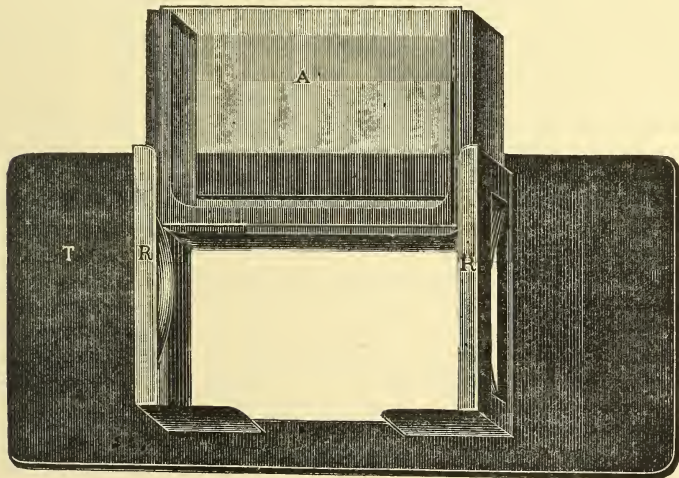

on which a strip of glass bent into the form | \_\_\_ | was cemented. This bent strip of glass served as side walls and bottom of the aquarium,

\* *Zeitschr. f. wiss. Mikr.*, x. (1893) pp. 148-51 (1 fig.).



while the object-holder formed the back wall, and a cover-glass, 30 by 40 mm., the front wall. The whole apparatus was fastened by clamps on the stage of a horizontally inclined Microscope. This aquarium could thus be very easily made; but it had the drawback, which made itself especially felt in embryological investigations, that it only allowed of observations being made from the side of the front wall.

On this account, in the new form of apparatus the aquarium proper is detachable from the holder. As seen in fig. 12, the aquarium A consists of a strip of glass 8 mm. broad, bent into the form , which serves as side-walls and bottom, and of two cover-glasses, 30 by 40 mm., which are cemented by Canada balsam to the glass strip and form the front and back walls.

The holder T for the reception of the aquarium consists of a metal plate of dimensions 4 by 9 cm. with a large rectangular aperture, on the sides of which two strips of metal bent at right angles are riveted. In the frame R thus formed, which is provided with two springs, the aquarium is inserted with either cover-glass in front, so that creatures which have attached themselves to either one or the other cover-glass can be brought under observation.

**Apparatus for Regulating the Temperature of Hatching-Ovens, &c.\***  
—Herr A. Koch describes the method of regulating the temperature made use of in the hatching-ovens supplied by Sartorius of Göttingen. For this purpose there is in the interior of the oven a metal capsule containing a liquid, with a high co-efficient of expansion, which, as the temperature rises, causes the walls of the capsule to bulge outwards. This has the effect of raising the rod S (fig. 13) which rests upon it. This rod then acts upon the lever *j g h*, from the free end of which *h* hangs a chain, carrying a cover *d*, which fits over the chimney *s* of the heating apparatus. From the side of the chimney projects at right angles a tube *c*, which traverses the water-jacket of the oven and emerges again near the place where it entered.

When the cover *d* closes the top of the chimney, the hot air from the flame passes into the horizontal tube and warms the water of the oven. As the temperature in the interior rises up to a certain point, the capsule *k* (represented more particularly at B) expands until the rod S acts on the adjusting screw *j* of the lever, and the cover is lifted off the chimney. As soon as this happens the hot air from the flame passes out freely from the upper end of the chimney *s*, and ceases to warm the oven. The latter therefore begins to cool, the capsule works in the opposite way, the cover closes over the chimney, and the oven is again heated.

The adjustment of the apparatus for definite temperatures is easily effected by means of the adjusting screw *j* of the lever, and the sliding weight *g*, which can be fixed in any position on the arm. The apparatus allows of temperatures from 20° to 70° being kept constant, but for the production of the different temperatures, in all, six different capsules *k*, each covering an interval of 10°, are necessary.

To prevent, as far as possible, the apparatus from being affected by the variations in temperature of the surrounding air, the space be-

\* Zeitschr. f. wiss. Mikr., x. (1893) pp. 161-4.



tween the water-jacket and the outer walls of the oven is filled with non-conducting earth X.

In filling the water-jacket, water is poured in through a hole in the upper surface of the oven, until it begins to flow out from a side opening at *a*.

To prevent the condensation of water, the chimney and side tube projecting from it are covered with a metal jacket *m*, which tends to reduce the cooling of the parts of the tube outside the oven.

FIG. 13.

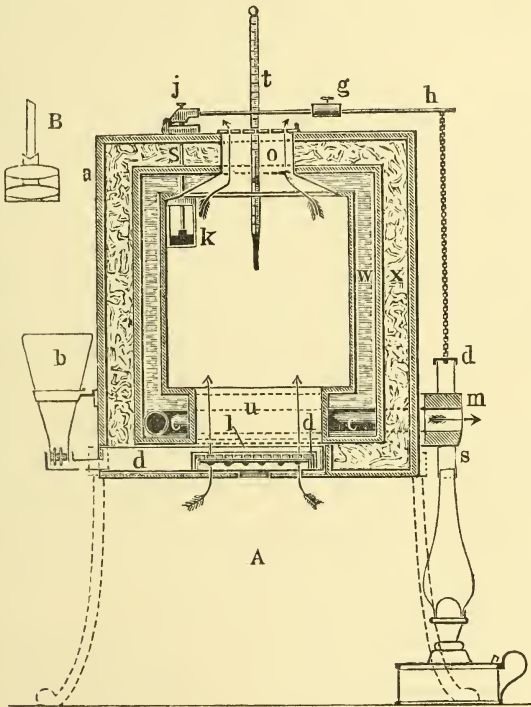

The oven, finally, possesses an arrangement for ventilation by moist air. For this purpose the insulating jackets are cut through above and below at *o* and *u*. The upper opening is closed by two metal plates, which are pierced by two holes, and can be adjusted so that the holes fit over each other and give passage to the air, or not. The air entering from below passes over a box *d d*, in which a piece of moist linen *l* is stretched. The water for keeping this linen moist is supplied by an inverted Erlenmeyer flask *b* outside the oven, which is in communication with the box *d d*.

**Cultivating Protozoa.\***—Prof. M. Ogata has obtained pure cultivations of a few Infusoria, e. g. *Polytoma wella*, *Paramæcium aurelia*, on

\* Centralbl. f. Bakteriol. u. Parasitenk., xiv. (1893) pp. 165-9.

artificial nutrient media. The medium is composed of meat-broth 500 ccm. (250 grm. meat), grape sugar 12·5 grm., and 25·0 grm. of an alga mixture, chiefly *Porphyra vulgaris*. This is boiled, neutralized, filtered, and sterilized in glass vessels.

A single species is isolated from its natural habitat and separated from bacteria, &c., by means of a capillary glass tube; the external diameter of this is 0·4–0·6 mm., the lumen about 0·3–0·5 mm., and the length 10–20 cm. One end of the tube is immersed in the medium, and when all but 1–2 cm. is filled it is removed to the fluid containing the Bacteria and Infusoria, and the remaining space completely filled. The two fluids must not be separated by an air-bubble. Both ends of the capillary tube are then sealed up in the flame. In from 5–30 minutes the Infusoria will be found on microscopical examination to have invaded the medium, and when they have removed several centimetres from the original fluid the spot is marked under the Microscope, broken off, and the end melted up. In this way one or several Infusoria may be isolated and kept alive for a month, but on the whole they do not thrive in the capillary tube. So the medium, placed in test-tubes, is inoculated with the contents of a tube which has been ascertained to be pure. The ends are broken off and the contents blown in. The Infusoria grow slowly, and clouding of the medium is not visible to the naked eye for 7 or 8 days, though microscopical examination will reveal presence of the organisms before this. After a time a distinct scum forms on the surface.

*Polytoma uvella* can also be grown on solid media by making plate cultivations and inoculating them from the fluid in which they are contained.

The colony on the plate may be recognized as a little white point in from 7 to 8 days. In 2 to 3 weeks it attains size of a millimetre. There is no liquefaction of the gelatin. The colonies are mostly round, and the centre of the larger ones dark and somewhat yellowish, while the periphery is greenish. The form and structure of the cells is easily made out, but their movements are sluggish.

Puncture cultivations also succeeded, though the colonies along the track were less strong than those on the surface.

**Puncture Cultivations.\***—Dr. Beneke points out that puncture cultivations can be rendered much more useful if the needle be thrust into the medium close to the glass instead of being stuck down the centre of the tube. This could be done with the ordinary straight needle, but better if it be bent to the shape of a bayonet. In this way the growing colonies can be observed microscopically even with objectives of short focus.

**Culture Media for Biochemic Investigations.†**—Dr. E. A. de Schweinitz finds that Fermi's solution—which consists of 1000 ccm. H<sub>2</sub>O, 0·2 grm. magnesium sulphate, 1·0 grm. acid potassium phosphate, 10 grm. ammonium phosphate, and 45 grm. glycerin—forms an excellent basis for general cultivation purposes when mixed with nutrient substances appropriate to the particular organisms. Thus, for hog-cholera and swine-plague 1 per cent. agar is added, and in this medium the

\* Centralbl. f. Bakteriol. u. Parasitenk., xiv. (1893) pp. 174–5.

† New York Med. Journ., lvii. (1893) p. 267.

germs of these diseases grow quite characteristically. For tuberculosis the above-mentioned solution of salts containing 7 per cent. glycerin and 1 per cent. pepton, and for solid media this latter liquid without pepton plus 1 per cent. agar was used. The growth of the germ in both these media is rapid and characteristic.

For the cultivation of glanders the mode of preparation was the same as for tuberculosis except that only 5 per cent. glycerin was used, the solution was allowed to remain slightly acid instead of being neutralized, and no pepton was added.

The solution of salts used for these media when first prepared is alkaline, but by boiling it can be rendered neutral or acid as ammonia is given off.

**Inoculation Apparatus for Rats and Mice.\***—Dr. K. Müller uses an apparatus for fastening down rats and mice when required for inoculation purposes. It merely consists of a board with a couple of spring clamps, one at either end; one of these serves to fix the tail, and the other the forceps which hold the neck. To ensure perfect stillness, a second pair of forceps applied to the loose skin about the neck or lower jaw, and fetters for the feet are necessary.

**Hot-water Thermostat with Automatic Regulator.†**—Dr. E. A. Schepilewsky has devised a thermostat which is heated by a current of hot water, and in which the desired temperature is maintained by means of an automatic regulator. In general plan the apparatus somewhat resembles that of Kurtzschinski,‡ and the regulator is not unlike that of Heydenreich.

The apparatus consists of three parts, the thermostat A, the boiler B, and the regulator C, C'. In the water-jacket of the thermostat is a worm (only partially represented in the illustration, fig. 14) made of thin copper tubing with a diameter of 7–8 mm. The boiler is a copper vessel incased in asbestos. At its top are two apertures *a* and *b*; the former, always open, is for pouring in water, the latter is closed by a cork through which passes a glass tube with an elbow. The lower end of the tube reaches below the water-level in the boiler, and its upper end is connected with a rubber tube *d*, through which the water passes to the thermostat. At the bottom of the boiler is the short tube *e*, connected with the rubber tube *e e*, by which the water is returned from the thermostat to the boiler. The source of heat is a petroleum lamp. The regulator consists of two parts, a glass reservoir C, and a set of tubes C' fixed to a piece of board. The Y-piece *fff* is intercalated in the course of the rubber tube *d*. It is a glass tube with a diameter of 6–7 mm. the arms of which are set at an angle of about 80° while the leg *i*, 8 cm. long and 3 mm. in diameter, is connected by means of a rubber tube *o o* with the glass cylinder K (8 mm. in diameter and 10–12 cm. long). The upper end of K is connected with the reservoir C, by a thick rubber tube *l*, having an internal section of only 1–2 mm. The reservoir C, made of thin glass, is 2 cm. in diameter, and 24 cm. long. Passing through its upper end and reaching nearly to the bottom is a stout glass tube, the external extremity of which is T-shaped, one arm

\* Centralbl. f. Bakteriol. u. Parasitenk., xiii. (1893) pp. 596–7 (1 fig.).

† Op. cit., xiv. (1893) pp. 131–8 (1 fig.). ‡ See this Journal, 1893, pp. 384–5.

being connected with the rubber tube *b* and the other with a clamped tube *t* plunged into a vessel filled with water. The large reservoir *C* is filled with ether and water, the small reservoir *k* with mercury and water. The water in the apparatus is distilled. The boiler must always stand at a lower level than the thermostat, in order that the heated water may flow upwards easily. The apparatus is regulated

FIG. 14.

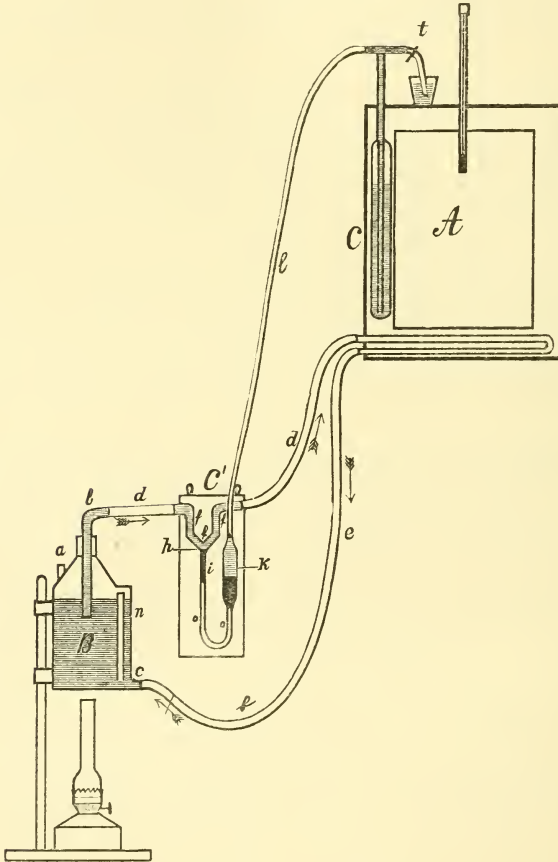

for any desired temperature by raising or lowering the small reservoir *k*, if the difference do not amount to more than  $2^{\circ}$ ; if, however, higher temperatures be desired, the clamp at *t* is undone and some water allowed to escape from the reservoir *C*; if a lower temperature be required, the petroleum lamp is removed, the clamp at *t* opened and some water allowed to be sucked in from the glass vessel. The general principle of the regulator is that as the water in the jacket



of the thermostat gets hotter the ether expands in the reservoir C, drives the water on to the mercury in *k*, and this ascending into the Y-shaped tube *fff*, cuts off the hot stream from the boiler. Numerous and complicated details are given for the avoidance of air-bubbles, but for this the original must be consulted.

**Cultivating Ascospores.\***—Dr. H. Wichmann says that he has cultivated ascospores on firebrick blocks since 1888. They are shaped like a truncated cone, the upper surface having a diameter of 55 mm., the lower 65 mm., and the height being 30 mm. The broader surface is somewhat hollowed out. The blocks are cleaned by first scrubbing and drying them, after which they are sterilized by exposure for two hours to a dry heat at 150°. During the sterilizing they are placed inside a glass vessel, the lid of which is left loose, the whole contrivance being wrapped up in filter-paper.

The conical form of these blocks prevents the cultivation surface from coming in contact with the side of the containing glass vessel, and thus prevents the condensation water from damaging the cultivation.

**Cultivating Vibrios.†**—In his experiments with water vibrios Dr. J. Sanarelli used large quantities of water for isolating these organisms. Usually 200 ccm. of liquid were poured into a sterilized flask sufficiently large for a large surface of water to be in contact with air, and then 8 ccm. of the following mixture were added:—Gelatin 20; pepton 10; sodium chloride 10; potassium nitrate 1.

This mixture, made in advance, is kept in sterilized tubes, and when dissolved up for cultivation purposes has the following composition:—Gelatin 2; pepton 1; sodium chloride 1; potassium nitrate 0.1; water 100. In this medium vibrios thrive excellently well when incubated at 37°, and in twelve hours form a surface scum, from which loopfuls may be removed for microscopical or further bacteriological experiments. In the latter case the loopful should be plunged into a tube full of sterilized water, and from this dilution gelatin plates may be made. In this way perfectly pure cultivations are easily obtained.

The author further notes that the presence of too much albuminoid matter, e. g. meat broth, more especially with agar, is detrimental to the development of vibrios, and replaces it with distilled water. By this substitution is obtained a medium of exceptional transparency, which is peculiarly adapted for the cultivation of all kinds of vibrios at incubation temperatures; it has also been employed for differential diagnosis of various species of vibrios.

**Cultivation Media for Anaerobic Bacteria.‡**—Prof. F. G. Novy recommends the following media, all of which he has used with success, for the cultivation of anaerobic bacteria:—

(1) Meat broth, to which are added 1/2 per cent. sodium chloride, 2 per cent. grape-sugar, and 2 per cent. pepton. (2) The foregoing, plus the addition of 2 per cent. gelatin. (3) 10–15 per cent. gelatin to which salt, pepton, and grape-sugar have been added as above. (4) 1/2–2 per cent. agar, with the addition of salt, pepton, and grape-sugar

\* Centralbl. f. Bakteriol. u. Parasitenk., xiv. (1893) pp. 62–3.

† Annales Inst Pasteur, vii. (1893) pp. 700–2.

‡ Centralbl. f. Bakteriol. u. Parasitenk., xiv. (1893) pp. 595–9.

as before. To all of these media litmus may be added; and their reaction should be slightly, but distinctly alkaline.

The addition of litmus would seem to be valuable, not only as an indication of the reaction excited in the media, but also because it seems to possess some action protective of anaerobic bacteria.

**Urine-Agar for Cultivating Diphtheria Bacillus.\***—Dr. H. Schlosser obtained very favourable results from using urine-agar for cultivating the bacillus of diphtheria, though the method has no superiority over that of Loeffler, who used blood-serum mixed with 25 per cent. grape-sugar meat-broth.

Urine-agar is a mixture of 2 parts of meat-pepton-agar and 1 part sterile urine. Sterile urine was obtained by first washing the external meatus with sublimate, and then passing the urine into sterilized test-tubes. The urine was used in this condition or was sterilized by heating for half an hour to 70°–80°.

**Growth of Cholera Bacilli on Potato.†**—Dr. O. Voges found that cholera bacilli inoculated on ordinary potato do not grow, but when 2–3 per cent. common salt is added, the organisms develop freely. A very similar result to the latter is obtained when the potato is treated with 1/4–1/2 per cent. soda. The temperatures used in the experiments were 37° and 20°, and the only difference was that growth was less rapid at the latter.

It would seem that the effective factor is the presence of sodium chloride rather than the chemical reaction, for the reaction of the potatoes treated with common salt was acid, and the others alkaline, the results being in both instances approximately equal.

**Isolating Bacillus of Diphtheria from Toys.‡**—Dr. R. Abel adopted the following procedure for determining the presence of diphtheria organisms in a box of bricks which were suspected of being the source of contagion. After several unsuccessful attempts made by scraping the surface of some of the bricks and sowing the scrapings in blood-serum, agar, and bouillon, the whole lot of bricks were finally soaked for about half a minute in sterilized bouillon.

Serum and agar tubes were inoculated with some drops of the bouillon. A guinea-pig was inoculated with 1 ccm., and the residue was incubated in a flask. On the third day after the inoculation the guinea-pig died with symptoms of diphtheria, and undoubted diphtheria bacilli were found at the inoculation site. Apparently only one serum-tube took with diphtheria, while in the bouillon diphtheria bacilli were found on the sixth day, and urine-serum subcultures from this bouillon showed diphtheria colonies. Some of this was mixed with salt solution, and 0·1 ccm. was injected into a guinea-pig, which died of diphtheria on the third day. Round about the inoculation wound there was hæmorrhagic œdema of the subcutaneous tissue, with considerable hyperæmia of the skin, effusion in the pleural sacs, hæmorrhagic consolidations in the lungs, catarrhal nephritis, swelling and redness of the adrenals. Pure cultivations were obtained from the inoculation site, cultures from other parts remaining sterile. It was therefore concluded that the bricks were the source of the contagion.

\* *Centralbl. f. Bakteriologie u. Parasitenk.*, xiv. (1893) pp. 657–62.

† *Op. cit.*, xliii. (1893) pp. 543–50.

‡ *Op. cit.*, xiv. (1893) pp. 756–61.

## (2) Preparing Objects.

**Investigating Histology of Vertebrate Liver.\***—Dr. H. J. Berkley recommends the following as a method for showing the hepatic nerves. Liver tissue is cut into slices not more than 1.5 mm. thick, and while quite warm, is immersed in a saturated solution of picric acid, diluted with an equal volume of warm water. After remaining in this for from 15 to 30 minutes, it is immersed for 48 hours in a hardening fluid composed of 100 parts of aqueous solution of bichromate of potash (saturated in sunlight) and 16 parts of 2 per cent. osmic acid; this solution must be made several days before, and exposed to full sunlight. The specimens, however, must be hardened in absolute darkness at a temperature not lower than 25°; after hardening, the tissue is to be treated with 0.25 and 0.75 per cent. silver solutions in the usual manner, and allowed to remain in them for five or six days. After very rapid washing in running water they must be rapidly dehydrated, immersed for a few minutes in celloidin, placed on a cork, and the celloidin hardened in 75 per cent. alcohol in a closed jar; this jar is to be cooled either by ice or under a current of cool water, so as to harden the celloidin as rapidly as possible. The sections are then to be cut under 95° alcohol, rapidly dehydrated, cleared in oil of bergamot and mounted in xylol-balsam without cover-slip. The details obtained by this method are clearer than if the rapid silver process is used.

**Embryology of Chiton.†**—Mr. M. M. Metcalf found that of the agents used to fix embryos of *Chiton* the best results were, perhaps, got with an aqueous solution of picric acid to which sufficient sodium chloride was added to bring the solution to the density of sea-water. In the early stages it was necessary to remove the chorion and the yolk with which all the cells were crowded; for this purpose eau de Labarraque (hypochlorite of soda) was used; the embryos were passed from water into the ordinary eau de Labarraque, cold and of full strength; after one-third to three-quarters of a minute they were removed to water, where the chorion soon swelled to more than twice its usual size, and could be removed by agitation of the water or by currents from a pipette.

The sodium hypochlorite, if allowed to act for three minutes or more on the embryos, completely dissolves them. As it acts, however, much more rapidly on the yolk than on the protoplasm and nuclei, it is possible, by regulating the time of immersion, to obtain embryos with the yolk almost wholly dissolved, and the protoplasm and nuclei almost uninjured. Though the method is crude it was the only way by which Mr. Metcalf was able to successfully get rid of the yolk.

In staining early stages, after treatment with the eau the embryos were placed in weakly acidulated water, and passed thence into Delafield's hæmatoxylin. As the acid washes out from the protoplasm before it leaves the yolk-granules, one may, by regulating the time of immersion, obtain preparations in which the nuclei and cell-boundaries are well stained, while the yolk-granules are unstained.

\* Anat. Anzeig., viii. (1893) pp. 772 and 3.

† Stud. Biol. Lab. John Hopkins Univ., v. (1893) pp. 251-3.



**Investigation of Reticulated Tissue.\***—M. L. Demoor found that the most satisfactory results were obtained with organs fixed in Hermann's fluid for from six to fifteen days. After this the pieces should be washed in running water, and left for a day in absolute alcohol; they should then be put in acetic acid, again washed, and again placed in absolute alcohol. By this means the protoplasm is more deeply stained, and there is no need for double staining. A concentrated solution of corrosive sublimate or of chrom-acetic acid may also serve as the fixing agent. Safranin was found to give very good results as a staining reagent. The author did not make use of several ingenious methods, such as artificial digestion with trypsin, which have been proposed, as he feared they would produce artificial or pathological changes.

**Method for the Histological Examination of Osseous Tissue.†**—Dr. J. Schaffer, in a review of the technique of the minute anatomy of bone, has put in a compendious form the advice of most well-known histologists on the preparation of osseous tissue for microscopical demonstration. In the course of his remarks the author mentions the experience of eighty different writers who have devoted some attention to the finer structure of bone, and discusses the procedures for examining bony tissue under the following heads:—Examination of fresh bone tissues; making sections of undecalcified bone; sections from decalcified bone; demonstration of bone cells, canals, and canaliculi; examination of the ground substance and of the soft parts of bone; how to examine for the developmental appearances; and the examination of bone by polarized light.

**Demonstration of Psorosperms.‡**—Dr. Heneage Gibbes makes a saturated solution of anilin oil, to which he adds a 2 per cent. solution of rosanilin sulphate for his No. 1 stain, and a 1 per cent. solution of iodine-green for his No. 2 stain. Stain No. 1 is filtered into a watch-glass, and in it there are left for 10 minutes some sections of rabbit's liver, hardened in alcohol. After washing in water and then in alcohol, they are placed in stain No. 2. The staining may be considered to be sufficient when the original red colour has changed to a dull purple. If the sections are now washed in water, alcohol, clove-oil, balsam (xylol) the parasites are stained red, nuclei and leucocytes green, fibrous tissue and protoplasm of liver cells purplish-red. Dr. Gibbes was unable by this method to demonstrate parasites in sections of fresh cancer, and he appears to doubt their presence.

**Conservation of Bacterial Cultivations by means of Formalin.§**—Dr. G. Hauser has observed that gelatin which has been exposed for some time to the action of formalin can no longer be liquefied at any temperature, even in the flame of a Bunsen's burner or by boiling in soda. At the same time it seems to have a permanently disinfecting action. If a plate fixed by means of formalin be exposed for a whole day, the development of aerial germs is never observed, nor can other cultures be successfully inoculated thereupon.

\* Arch. de Biol., xiii. (1893) pp. 5-7.

† Zeitschr. f. wiss. Mikr., x. (1893) pp. 167-211.

‡ Amer. Journ. Med. Sci., July 1893. See Brit. Med. Journ., 1893, No. 1703, p. 32.

§ Münchener Med. Wochenschr., 1893, No. 33. See Centralbl. f. Bakteriol. u. Parasitenk., xiv. (1893) pp. 468-9.



Thus tube and plate cultivations can be permanently preserved provided that they be prevented from drying. Formalin may also be used for making permanent microscopical preparations. A flat piece containing the colony is cut out of the gelatin plate with a sharp knife; this is placed on a slide, imbedded in gelatin, and a cover-glass put over. The preparation is then put in a formalin-chamber for 24 hours, by which time the imbedding gelatin is fixed as well as the rest of the specimen. The preparation is then run round with some protective.

The cultivations may also be stained by placing the pieces from the gelatin plates for 24 hours in a weak aqueous solution of fuchsin; the bacteria are deeply stained, while the gelatin is only of a pale red hue.

Stained preparations may be imbedded and mounted as before, or they may be allowed to dry on the slide, and then mounted in Canada balsam.

(3) Cutting, including Imbedding and Microtomes.

**Leitz's Microtome.\***—In this instrument, represented in fig. 15, the preparation is firmly held in a carriage moving vertically in a groove

FIG. 15.

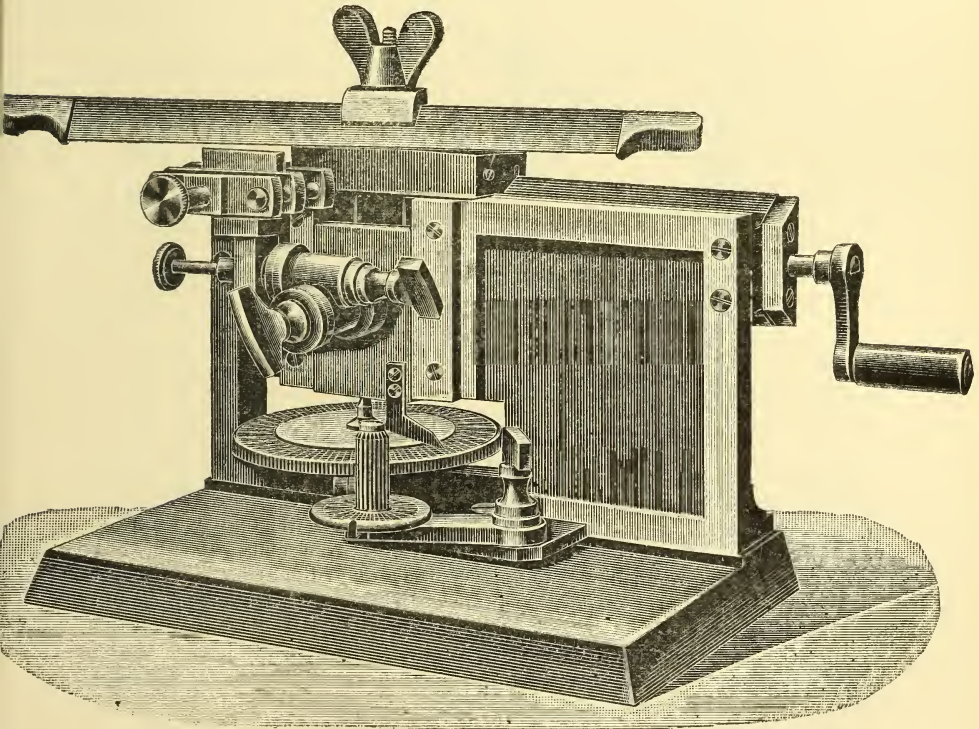

\* Catalogue No. 34 of Microscopes and Accessory Apparatus, Ernst Leitz, Wetzlar, 1892, p. 41.

and is raised by means of a graduated micrometer screw. The sliding of the knife is effected by a crank so that the irregularities of movement, inevitable when the hand alone is used, are avoided.

**A New Section-stretcher.\***—Prof. G. Born describes a new device for preventing paraffin-sections from rolling up. It depends upon the principle of holding down the section with a minimum amount of force. The apparatus employed for this purpose consists, as shown in fig. 16, of an equilibrated lever *a* which turns very easily about a horizontal axis *x* fixed in a fork *g*. This fork can be displaced along a horizontal rod and

FIG. 16.

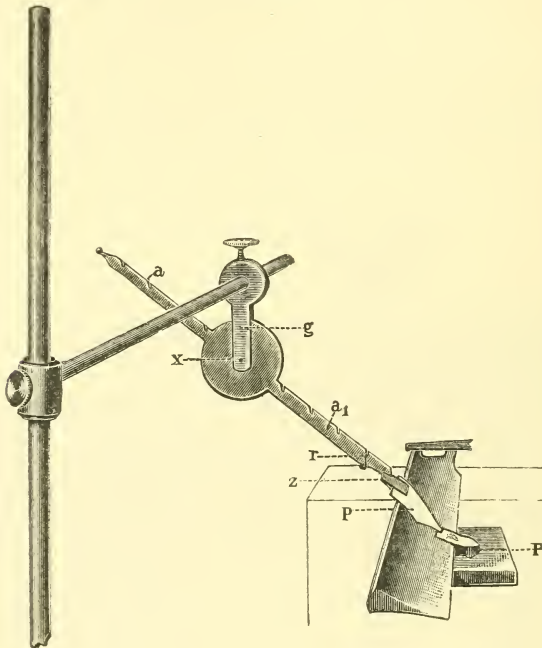

fixed in any position by means of a screw. The horizontal rod can be adjusted in height on a vertical holder. The lever carries at one end a small flat spring-clamp *z*, in which is fastened a piece of paper *p*, rounded or cut square at the free end. The weight of the paper is not sufficient to disturb the equilibrium of the lever in favour of the arm *a*<sub>1</sub>. A small rider of wire is therefore placed in one of the notches on the upper edge of the lever. The instrument is so adjusted that the free end of the paper lies on the front edge (the edge turned towards the knife) of the paraffin-block *P*. During the forward motion of the knife through the paraffin-block the paper keeps the section on the blade. The section can then be very easily removed with a broad needle. When the knife

\* *Zeitschr. f. wiss. Mikr.*, x. (1893) pp. 157-60.

is brought back, the paper again falls on the edge of the paraffin-block, and the process can be repeated.

Another mode of using the instrument, which may be advantageous in certain cases, consists in fixing the fork *g* on the horizontal arm in the opposite direction so that the clamp-arm *a*, of the lever points away from instead of towards the microtome. In this case in the forward motion of the knife the effect of the paper is to push the section up the blade.

The thinner the sections, the smaller should be the rider and the nearer to the axis should it be suspended. The kind of paper used should also vary with the thinness of the sections.

#### (4) Staining and Injecting.

**Fiocca's Method for Spore-Staining.\***—Dr. R. Fiocca states that by the following method spores can be stained with great efficiency and certainty. The reagents necessary for the process are a 10 per cent. solution of ammonia, an alcoholic solution of an anilin dye, a 20 per cent. decolorizing solution of sulphuric or nitric acid, and an aqueous solution of a contrast stain. Into a capsule are poured about 20 ccm. of ammonia solution, and then are added 10 to 20 drops of the alcoholic solution of the anilin pigment. The solution is warmed until it begins to vaporize, and then the already prepared cover-glasses are treated therewith in the usual manner.

On the average, spores are stained in from 3 to 5 minutes, and only in the case of very resistant spores, such as anthrax, are 10 to 15 minutes required. When sufficiently stained, the preparations are treated with the decolorizing fluid; they afterwards are washed in water and then contrast-stained.

For staining spores, alcoholic solutions of gentian-violet, fuchsin, methylen-blue, safranin give excellent results; and for contrast, aqueous solutions of vesuvin, chrysoidin, methylen-blue, malachite-green, and safranin may be used.

By this method not only are the spores stained, but those protoplasmic granules which precede spore-formation, while degenerative conditions are unaffected.

As in Gabbett's formula for bacilli of tubercle the contrast-stain may be dissolved in the decolorizing solution; but in such case the solution must be less strong (not more than 10 per cent. of acid), and the preparations remain therein a correspondingly longer time.

**Employment of Vesuvin for Fossil Plants.†**—Herr O. Lignier recommends the use of an alcoholic solution of vesuvin for staining sections of fossil plants which have first been cleaned by chloroform. It is especially useful for bringing out the xylem portion of the vascular bundles.

**Demonstrating Intercalary Rings of Nerve-fibres.‡**—M. B. Ségall adopts the following procedure for examining medullated nerve-fibres. A quite fresh nerve, from a frog or a guinea-pig, a day old, is rapidly teased out in a few drops of 1 per cent. osmic acid. When the nerve

\* *Centralbl. f. Bakteriologie u. Parasitenkunde*, xiv. (1893) pp. 8-9.

† *Bull. Soc. Linn. Normandie*, vi. (1892) pp. 9-10. See *Bot. Centralbl.*, lvi. (1893) p. 18.

‡ *Journ. Anat. et Physiol.*, xxix. (1893) pp. 586-603 (1 pl.).



has turned brown it is transferred to distilled water, in order to remove excess of osmic acid, and then teasing out is resumed in a 2 per cent. solution of silver nitrate. The nerve-bundle is exposed to light for 20, 30, or 40 minutes, and must be occasionally moved about. The excess of silver nitrate is removed in distilled water and the preparation mounted in glycerin.

Impregnation is much facilitated if the nerve-fibres are treated with an aqueous 1 per cent. solution of eosin, neutral carmine or even hæmatoxylin before mounting in glycerin.

By this method the author claims that a series of rings situated at the level of the myelin segments can be demonstrated, and from the illustrations it would seem that the overlapping of two myelin segments is related to the well-known appearance called Ranvier's node, the cuff of the outer myelin tube overlapping the inner segment being the transverse bar of the Latin cross.

**Cox's Method for Demonstrating the Nerve-fibres of Central Nervous System.\***—Prof. S. Ramón y Cajal found that Cox's method gave very satisfactory results when employed for demonstrating nerve-fibres in the cornu Ammonis and elsewhere. This procedure consists in placing pieces, not too large, in the following fluid:—5 per cent. bichromate of potassium, 20 parts; 5 per cent. sublimate, 20 parts; distilled water, 30–40 parts; 8 per cent. chromate of potassium with strongly alkaline reaction, 16 parts. In this fluid the pieces remain for 2–3 months in the winter, and at least one month in the summer. Before being imbedded the pieces are immersed in 36° alcohol for 30 to 60 minutes. The sections are placed in 40° alcohol, cleared up in oil of cloves, mounted in xylol-dammar without a cover-glass.

The author also used the Weigert-Pal and Golgi's rapid methods, and also tried Berkeley's rapid method (osmic-copper-hæmatoxylin), of which he speaks very favourably.

**Examining Street Dust for Tubercle Bacilli.†**—The examination of dust from the street, dwelling-rooms, of dirty water, &c., depends, says Dr. Marpmann, for its success on the recognition of those granules into which the bacilli have become disintegrated rather than finding the intact organisms. The staining reaction is exactly the same, but the red particles require to be sought for with an apochromatic immersion instead of with the ordinary 1/12. The dust used for the examination was just scraped up and digested for some hours in water at 40°; it was then strained through a woollen cloth. Some of the filtrate, about 50 ccm., was then treated with a drop of iron chloride, and 10 drops of carbonate of ammonia in solution. A precipitate of iron oxide and earthy carbonates slowly formed, and this was separated either by sedimentation for twenty-four hours in a conical glass or by centrifuging.

The sediment was then stained on cover-glasses with phenol-fuchsin treated with hydrochloric acid-alcohol (HCl, 0·5; 80 per cent. C<sub>2</sub>H<sub>6</sub>O, 100) and examined in fat-blue (*Fettblau*) in xylol.

It only remained to find out whether these fragments of bacilli were infectious, and cultivations were made therefrom in agar tubes and

\* Zeitschr. f. wiss. Zool., lvi. (1893) pp. 616–8.

† Centralbl. f. Bakteriol. u. Parasitenk., xiv. (1893) pp. 229–24.



in bouillon. After an incubation of four weeks a microscopical examination showed that tubercle bacilli were as constantly present in the agar and as constantly absent from the bouillon.

(5) Mounting, including Slides, Preservative Fluids, &c.

**Formalin as a Hardening and Preservative Medium.\***—Prof. F. Hermann writes very enthusiastically on the fixative and preservative properties of formaldehyde, known commercially as formalin. Used in 0·5 to 1·0 per cent. solution it is found to thoroughly fix and harden not only pieces but whole organs (e. g. a calf's heart) in from 12 to 24 hours. Its particular advantage is that the transparency of living tissues is almost perfectly retained, the best examples of which are those of the eyes of small animals. Formalin also preserves the natural colours of the skin, though it rapidly extracts blood-pigment, and thus bleaches portions of the preparation, yet its fixative property, coupled with the advantages of preserving the transparency of tissues and structure, and its conservation of the natural colours of integuments indicate that it is especially adapted for museum purposes. As a fixative for microscopical preparations formalin has no advantage over the ordinary fixative media. It fixes as well but not better, and its use is associated with the inconvenience that tissues previously treated with formalin are not suited for after hardening with alcohol. It is obvious, therefore, that until this inconvenience has been surmounted, the use of formalin cannot be recommended when microscopical sections are required.

**Cleaning New Cover-glasses.†**—Prof. Zettnow finds that the best way to remove all traces of grease, which prevents the regular distribution of fluids, from new cover-glasses is to burn it off, and for this purpose he uses a piece of sheet iron 8–10 cm. square. The imperfectly cleaned cover-glass placed on the iron is held in the flame of a Bunsen's burner for several minutes. The glasses never crack, and twelve to fifteen can be cleaned at a time.

**Dr. M. Kuster's Hollow Spheres for Microscopic Objects.‡**—Dr. A. Zimmermann gives the result of his examination of Dr. Max Kuster's hollow spheres. They are made of thin glass, and have a diameter of about 15 mm., with a circular opening about 3 mm. wide, through which the objects to be observed are introduced. For observation, the spheres can be brought directly under the Microscope, and serve at once as object-holder and cover-glass. The use of the spheres is naturally confined to small objects suspended in liquids; they are therefore especially recommended for preparations of bacilli.

A further advantage claimed for them is that the reagents, which are simply introduced into the hollow space, in this way act much more uniformly and intensely, while no air-bubbles or displacements are produced as when a cover-glass has to be raised.

A disadvantage in the new method consists in the difficulty experienced in the observation and in the displacement of the preparation.

\* Anat. Anzeig., ix. (1893) pp. 112–5.

† Centralbl. f. Bakteriol. u. Parasitenk., xiv. (1893) pp. 63–4.

‡ Zeitschr. f. wiss. Mikr., x. (1893) pp. 164–6.

The spheres can only be used when the object-stage of the Microscope possesses an opening suitable in size for their reception. Even where this is the case, the displacement of the spheres is not so easy as with the ordinary object-holders. The last two defects, however, may be remedied by the use of a metal plate having a suitable opening in the centre and provided with a rectangular screw-motion.

The use of the Abbe illuminating apparatus with the spheres is impossible, and this defect is not adequately remedied by filling the spheres with a strongly refracting liquid.

Altogether the author is not inclined to recommend the spheres in their present form for general use, although he does not deny that, if properly modified, they might be of good service in many cases.

#### (6) Miscellaneous.

**Atlas of the Clinical Microscopy of the Blood.\***—The object of Rieder's Atlas is to present in a few plates the numerous deteriorations in the histological characters of the blood for clinical purposes. The text is very condensed and serves merely for the explanation of the plates. All the illustrations are from original drawings, chiefly from stained preparations, though a few are uncoloured. The introduction gives the methods for the clinico-microscopical examination of the blood and describes the way to obtain a drop of blood, the fixation of dry preparations, eosin-hæmatoxylin staining, the demonstration of the nuclear structure of leucocytes, Ehrlich's granules, the blood-plates, the amoeboid movement of leucocytes, and a short recital of the course of clinical blood-examination.

The illustrations are well executed; the magnifications are 300, 400, and 1100, except three in which 1600 has been used for showing myelæmia and malaria plasmodia.

It would have added to the value of the work if there were a table of contents or an index.

**Diagnosis of Water Bacteria.†**—The second edition of this work by Dr. A. Lustig is published in Italian and German. It deals with water bacteria and pathogenic bacteria found in water, and describes 181 species. The first part deals with bacteria pathogenic to man, the second with those pathogenic to animals, and the third with non-pathogenic bacteria. The third group is subdivided into (a) Micrococci, (b) Bacilli, (c) Spirilla, (d) Schizomycetes of different developmental forms.

Micrococci and bacilli are further distinguished according as they liquefy gelatin or not. In each division the bacteria discussed therein are fully described in reference to form, arrangement, mobility, spore-formation, and development in different media. The diagnoses are in tabular form and resemble in this respect Eisenberg's tables, though the arrangement is different and less clear. The greatest share is devoted to bacilli found in water, yet it should be noted that the author's description of a bacillus does not accord with de Bary's conception. Of

\* Leipzig, 1893, 12 pls. and 48 figs. See *Centralbl. f. Bakteriol. u. Parasitenk.*, xiv. (1893) p. 208.

† Jena and Turin, 1893, 128 pp. See *Bot. Centralbl.*, liv. (1893) p. 335.

Micrococci forty-six are described, and among them are figured some species of *Sarcina*. Nine spirilla and twenty-one pathogenic bacteria are mentioned. With regard to *Crenothrix*, *Beggiatoa*, and *Cladothrix*, the old views controverted by Winogradsky about pleomorphism are still upheld. That writer's work on the sulphur bacteria appears to be quite unknown to the author, for *Beggiatoa* is full of contradictions throughout and it decomposes sulphur compounds with development of sulphuretted hydrogen.

**Kitt's Bacteriology and Pathological Microscopy.\***—Dr. Th. Kitt has published the second edition of his 'Bacteriology and Morbid Histology,' with an alteration of title. The work is intended for the use of veterinary surgeons and students; it is a text-book, in fact, but of a superior kind, and well adapted to the wants of those to whom it is addressed. The illustrations are numerous, and superior to those of the first edition.

**Gedoelst's Bacteriology for Veterinary Surgeons.†**—This book, which deals with the diseases of animals from a bacteriological standpoint, is intended chiefly for veterinarians, though much of it will be found useful to those occupied with human pathology. The first portion of the work is occupied with micro-biology, immunity, and other general questions; the second section deals with the bacteriology of separate diseases; and the third portion deals with bacteriological technique.

**Günther's Bacteriology.‡**—Dr. C. Günther has just published the third edition of his 'Introduction to the Study of Bacteriology and Microscopical Technique.' The work, which has been revised throughout, is much enlarged and brought up to date.

**Friedländer's Microscopical Technique.§**—The fifth edition of Friedländer's 'Microscopical Technique' has just been brought out by Prof. C. J. Eberth. The present edition is intended not only for beginners, but also for experienced histologists. The whole work has been thoroughly revised, and the most recent methods of researches are given in their appropriate places. Special attention has been devoted to the examination of the central nervous system, the demonstration of micro-organisms in tissues, and to photomicrography.

**Von Kahlden's Microscopical Technique.||**—The third edition of Von Kahlden's Technique for the Histological Examination of Pathologico-Anatomical Preparations has been improved, and enlarged to 122 pages. Special attention has been paid to the chapters on staining bacteria, the skin and the central nervous system, and to that on the examination of the blood. In the last chapter the examination of blood-spots, hairs, seminal fluid, and fragments of decidua are described.

\* Vienna, 1893, 450 pp., 140 figs. and 2 pls. See Centralbl. f. Bakteriologie u. Parasitenk., xiv. (1893) p. 858.

† Lierre, 1892. See Centralbl. f. Bakteriologie u. Parasitenk., xiv. (1893) p. 729.

‡ Leipzig, 8vo, 376 pp., 12 pls. See Centralbl. f. Bakteriologie u. Parasitenk., xiv. (1893) p. 729.

§ Berlin, 1894, 336 pp. See Centralbl. f. Bakteriologie u. Parasitenk., xiv. (1893) p. 741.

|| Jena, 1893. See Centralbl. f. Bakteriologie u. Parasitenk., xiv. (1893), p. 787.

## PROCEEDINGS OF THE SOCIETY.

MEETING OF 20TH DECEMBER, 1893, AT 20 HANOVER SQUARE, W.,  
THE PRESIDENT (A. D. MICHAEL, ESQ., F.L.S.) IN THE CHAIR.

The Minutes of the meeting of 15th November last were read and confirmed—subject to a slight alteration as under—and were signed by the President.

Dr. W. H. Dallinger on the reading of the minutes said that his remarks as there recorded on the subject of tube-length scarcely conveyed the idea he had intended. He did not for a moment suggest that the Society should be charged with the duty of such a committee, because the interest in the matter was world-wide and therefore the microscopists of other countries should be equally concerned in it. He would therefore like to make a slight modification by substituting for the last sentence “that the whole question should be dealt with by the appointment of an *International* Committee for the purpose.”

The List of Donations (exclusive of exchanges and reprints) received since the last meeting was submitted, and the thanks of the Society were given to the donors.

Eleventh Report of the State Mineralogist. (Svo, Sacramento, 1893)	From <i>The California State Mining Bureau.</i>
R. Lauterborn, Ueber Bau und Kerntheilung der Diatomeen. (Svo, 1893)	<i>The Author.</i>
4 Photomicrographs ( <i>Trichina spiralis</i> and blood-corpuscles)	<i>Dr. W. N. Sherman.</i>
Slide of <i>Arachnoidiscus</i>	<i>Mr. B. W. Priest.</i>

Mr. E. M. Nelson exhibited and described a new pattern Microscope specially designed for agricultural purposes, for the examination of seeds, leaves, &c., with low powers (see p. 107). Also a new form of metallic chimney for a Microscope-lamp fitted to carry a silvered convex lens, by means of which a powerful parallel beam of light can be projected through the glazed opening on the opposite side (see p. 109).

Mr. Nelson also, on behalf of Mr. J. W. Lovibond, exhibited some new coloured screens for use with the Microscope; he said that Mr. Lovibond, who was unfortunately prevented from coming that evening, had for some time past been experimenting with screens for microscopical work.

Screens or light-modifiers were an old invention, but partly owing to photomicrography their importance had of late become more fully recognized.

Mr. Nelson, who had for many years been using two thicknesses of pot cobalt glass, had received from Mr. Lovibond a piece of flashed peacock green. This glass, when used in combination with one thickness of the cobalt glass, gave better results than any hitherto obtained. The red was cut out, and a large quantity of blue passed; unfortunately



some orange rays were also transmitted. Notwithstanding this defect the screen was an excellent one for visual purposes. In order that these glasses might be accurately matched at any time, he appended the following tintometer values:—

Green glass = 6·2 Green + 10·3 Blue + 1·4 Excess of light.

Blue glass = ·46 Violet + 5·94 Blue.

Green and Blue glass = 2·7 Green + 16·3 Blue.

Mr. Lovibond had lately sent him a new screen composed of methylen-blue dissolved in water. A few granules of the powder of this highly concentrated dye were sufficient for one of the ordinary light filter bottles. This screen gave a broad dark band in the red, orange, yellow, and yellow-green portions of the spectrum, cutting them all out, with the exception of a small portion at the lower end of the red. Visually, it was a blue screen, the red being too weak to affect the eye, except when an exceedingly delicate test was used with an achromatic lens having a very red correction.

Photographically, the red had absolutely no effect, and as the screen passed freely those rays belonging to the higher portions of the spectrum, exposures were not unduly lengthened with ordinary plates.

The value of this screen consisted in the suppression of the yellow-green, yellow, orange and brightest part of the red, while the pure green, blue-green and blue were transmitted at almost full intensity.

Mr. Nelson felt sure that these excellent qualities possessed by Mr. Lovibond's screen would be appreciated by microscopists in general.

With regard to the density of the screen, he said in conclusion that it was better to err on the side of too light rather than of too dark a screen.

The President—in moving a vote of thanks to Mr. Nelson for his communications—said that the Microscope exhibited was one which might no doubt be very useful for the purpose for which it was designed, but it struck him that if it was to be used very much, some of the parts would require much more steady fixing than they seemed at present to possess; as it was, the reflecting mirror would almost fall out of position by its own weight and seemed very much in need of some means of clamping it. He thought also that it might be difficult to get the light in such a direction that the shadow of the objective would not fall upon the mirror if anything like a short focus was required.

Mr. Nelson said that all the movable fittings were sprung so that they could very easily be tightened up to any extent required to take up the wear. The Microscope was intended only for the examination of large objects with low powers, so that very short focus objectives would never be used.

---

Mr. Nelson said he had been prevented from attending the last meeting, otherwise he had intended pointing out several errors in the statements of facts made by Dr. J. B. Nias in his paper on the Continental form of Microscope.\* He said it was not his intention to criticize

\* See this Journal, 1893, p. 596.

any of the views Dr. Nias held concerning the Continental Microscope, but merely to point out some inaccuracies upon questions of fact. On page 596 it is stated that "the Continental stand has maintained its form without substantial alteration for nearly fifty years."

Mr. Nelson said that from his own knowledge he could not go back as far as fifty years, but during the past twenty-five he had personally witnessed the ceaseless changes the Continental Microscope had undergone. Those changes throughout had been in a direction away from the Oberhaeuser type, and towards the English model. Even while Dr. Nias was reading his paper Leitz was adapting a claw foot and horseshoe stage to his Microscope. It must be pointed out that the typical Continental Microscope had not followed the Oberhaeuser, for the Oberhaeuser had a large stage (4 in. in diameter) whereas the typical Continental Microscope had an absurdly small one. The reason for this is apparent. A large stage was possible with the Oberhaeuser model, because it had a foot as large as, if not larger than, the stage; but when the narrow horseshoe foot was introduced it was necessary to materially lessen the diameter of the stage, otherwise a slight pressure on one side of the stage would have careened the instrument. It was difficult now to find a typical Continental Microscope, but No. V<sup>b</sup> in Zeiss's 1885 catalogue might be taken as an example. This Microscope, which was not inclinable, had a horseshoe foot, a sliding tube coarse-, and direct acting screw fine-adjustment, its height was 12·2 in., the size of the stage 3·2 × 3·4 in., and price 4*l.* 15*s.* without lenses. This Microscope, which was remarkable for the large size of its stage when compared with others of its kind (a shade larger than Zeiss No. II.), did not quite conform to type inasmuch as it lacked the peculiar rotation of the limb and stage. If, however, one of that kind were selected a still smaller stage would be found, viz. one a trifle less than 2½ × 2¾ in. (Zeiss No. VI. 1885 catalogue; the microscope is however shorter, viz. 10·6 in.)

This kind of rotation was disappearing from Continental Microscopes, for Zeiss' 1885 catalogue, out of fourteen varieties of Microscopes, had four fitted with it, while his 1889 catalogue had only a single example out of twelve varieties. Concurrently with the disuse of this limb and stage rotation we found an increasing adaptation of the English method of rotation, for in the 1889 catalogue we had the No. II. stand fitted on the English plan, instead of on the Oberhaeuser, as in 1885.

Secondly, Dr. Nias has credited Strauss-Durckheim with priority of invention with regard to three points in the construction of the Microscope, the date of such inventions being given, viz. 1830-5. They are as follows:—

- (1) Rotating stage.
- (2) Provision for changing from compound Microscope to simple.
- (3) Erecting Microscope.

Mr. Nelson said he would not attempt to give the names of the first inventors of these several features of microscopical construction, his purpose would be served if he quoted an instance predating Strauss-Durckheim, viz. *ante* 1830-5.

- (1) A rotating stage (with rack and pinion movement!) was made by Benjamin Martin, 1782.
- (2) During the latter half of the last century many Microscopes had

their bodies made removable, so that the objective could be used as a simple Microscope.

The arm carrying the body and the objective was made so that it could rotate on a pivot, and further it was often fitted with rackwork extension, so that it could traverse the stage in any direction. This feature of swinging the body to one side had however long disappeared from the Continental Microscope. Messrs. Powell & Lealand were the only makers to retain it. In this they did not plagiarize the Strauss-Durckheim model, but they preserved the continuity of an English idea, which at that time had become the common property of Microscope-makers, both here and in France.

(3) A Microscope with an inner tube for an erecting lens was made by James Smith in 1826.

With regard to this point Mr. Nelson said that, apart from absolute certainty of the fact, he thought that the erecting Microscope was about 230 years old, having been invented by Eustachio Divini.\*

Dr. W. H. Dallinger said it was pointed out during the discussion † upon the paper, that so far from having remained the same, the Continental Microscope had been perpetually changing until at length it had actually put on a mechanical stage.

Mr. Nelson said it had not only been changing, but it had been progressing towards the English model all the time.

---

Mr. J. W. Gifford read his paper "On a new Monochromatic Light Screen," illustrating his subject by the exhibition of a number of photographs of spectra of the colouring matters used, and also by the various colour screens which were shown by means of the lime light lantern.

Mr. Nelson said he had listened with great interest to Mr. Gifford's communication and regarded the work done as being most valuable and just what had been wanted for a long time. His investigations had solved some very important questions and the results attained would be of use not only for ordinary microscopical work, but also for photographic purposes. A new feature was getting a solution so strong that a sufficient depth of colour was obtained by the quantity which could be put between two cover-glasses.

The President was sure that the Fellows of the Society would join in a hearty vote of thanks to Mr. Gifford for the account which he had given them of this very excellent piece of work in a direction where perhaps as much still remained to be done as in any other. The thanks of the meeting were unanimously voted to Mr. Gifford.

---

Mr. T. F. Smith read the following paper "On the Ultimate Structure of the Valve of *Pleurosigma Angulatum*," illustrating his remarks by numerous photographs shown through the lantern on the screen:—

"It is now four years ago that I had the pleasure of reading before you a paper ‡ on the ultimate structure of the *Pleurosigma* valve; in which I claimed to have figured, for the first time, structure which up to then had only been guessed at by prior observers. My remarks then

\* See this Journal, 1887, p. 149, fig. 16. † See this Journal, 1893, p. 577.

‡ See this Journal, 1889, p. 812.



were mostly confined to the structure of *P. formosum* as the coarser form and one likely by analogy to determine that of the finer forms of the same genus. At that time I had no positive evidence to offer as to the structure of *P. angulatum*, and so far my case was incomplete; but since then further investigation has given me the evidence required to complete my case, and this I beg to lay before you to night.

In the paper read I attempted to prove that each valve of this genus was composed of at least two layers of structure, differing from each other, that each side of the valve had different curves and each curve its distinctive structure. Of these layers the inner one was the more robust of the two, and the outer the one from which all my examples of torn structure had been taken. I further said that this outer layer consisted of bars of siliceous set lengthways on the valve in such a manner that the alternate interspaces allowed an image to be formed between them, giving rise to the well-known diagonal 'markings,' an example of which I showed that night under the Microscope. Subsequently to this I sent a paper to the New York Microscopical Society\* on the same subject; in which I claimed that my results were the outcome of a large illuminating cone of central light, but in a paper by Dr. Cox,† read on the same night, strong doubts were raised as to my light being either central or consisting of a large cone.

The greater part of Dr. Cox's paper has been reproduced verbatim—without any quotation from my own paper to accompany it—in the Journal‡ of this Society, and I think it is only fair to myself that I should be allowed to make some remarks to show that I was not so much mistaken, as to the character of my illumination, as Dr. Cox seems to think. He says, 'I am bound in candour to say that in most of Mr. Smith's prints I recognize similar effects to those which in my own work I attribute to oblique light.' And again: 'Going back from these to prints Nos. 10 and 11, we now find reason to accept these also as evidence of the same structure, though distorted by obliquity of light, so that they would not have been satisfactory taken by themselves.' Let me admit at once, that judging the two prints by their appearance only, and not taking into consideration the circumstances under which they were produced, Dr. Cox is quite justified in his strictures; but let it be remembered also that we are here dealing with a valve in which the layers lie so close together, that even a water-immersion objective of about 1.15 N.A. will not separate them when at the normal distance from each other. Then again there was the necessity of getting contrast enough to produce an image of sufficient density to print from, and at that time my photographic skill was not equal to getting this without stopping down somewhat the aperture of the sub-stage condenser. But while admitting the reasonableness of the conclusions, I was certain of the character of my illumination, and it only remained for me to try to produce photographically the same results as I was able to do visually. In this I have succeeded, and will now place the same objects, taken with the full aperture of the condenser, side by side of the old ones on the screen. Nos. 10 and 11 of my paper were taken, as I said, with the aperture of the condenser stopped down, and certainly the structure is

\* Journ. New York Mic. Soc., vii. (1891) p. 61.

† Tom. cit., p. 73.

‡ See this Journal, 1891, p. 657.



somewhat mixed up and distorted, but the new slides show only the barest indications of the structure underneath and the upper is quite free from distortion.

I said just now that even a water-immersion of about 1·15 N.A. failed to separate the two structures when at the normal distance on the valve, not because the resolving power is insufficient, but because the depth of focus pierces through both layers; which the next example will show you. This is the same as the last only taken with a dry 1/4 in., instead of the oil-immersion with which all the others are taken. Over the greater part of the valve there is no appearance of a double structure, but one strip is sufficiently isolated to allow it to be seen by itself, and I wish to point out that here the fibrils almost follow a straight line, while in the oil-immersion they are shown in short broken lengths, and on a line decidedly crooked.

I take it that the 1/4 in. dry stands in about the same relation to *P. formosum*, with regard to resolving power, as the 1/12-in. oil immersion does to the finer forms of this genus, and analogy here would decide us to come to the conclusion that although the fibrils on the latter may appear straight they are not necessarily so. The next slide is a case in point, where we see straight fibrils projecting over a hole in the valve, and was taken with the widest aperture of the oil-immersion.

We now come to *P. angulatum* proper, and my justification in treating somewhat minutely on its structure will be found in the fact that from the time when it was first resolved at all, it has been taken as the test with which to measure every advance in the performance of objectives; and before giving my own ideas of the structure, I propose to throw on the screen a few slides to represent the visual results obtained by objectives of different periods.

The first is from a photograph taken by myself with an old 1/12 in. of Andrew Ross—date 1850—and it was with a similar objective I suppose that Mr. Wenham took his celebrated photograph of this diatom. Unfortunately I have not done justice to this lens, but the characteristic appearance of *P. angulatum* at one particular focus is shown fairly enough. The next of the same diatom is also taken by myself with a Powell and Lealand 1/12-in. water-immersion of about 1·15 N.A.—date 1877.

Next on the table there is a print taken by Dr. Woodward with one of the earlier oil-immersions of Zeiss, and the fourth a copy of the same diatom taken with an apochromatic oil-immersion of 1·30 N.A. by Dr. Roderick Zeiss. Now, practically there is no difference between the images taken with the first lens made in 1850 and the last in about 1888, and had we to judge alone by the appearances here presented, we should say there had been no advance in the definition of micro-objectives whatever—that is in the sense of showing something new and not in the relative sharpness of the photographic images; but how unfair such an inference as this would be, I need not say to an assembly like this. We now come to a copy of one taken by Dr. Van Heurck with the new apochromatic of 1·63 N.A.; but with all respect I must say that I am afraid he has not done justice either to himself or to the objective, but owing to a preconceived idea of the structure has focused down into a sort of no-structure-land where all the spectra meet and jostle each other. My warrant for saying this is his statement that he focused on the inter-

mediate layer; a layer that I certainly have never been able to demonstrate in this genus except in *P. formosum*, and what is more to the point, does not seem to be demonstrated in this photograph.

To me the weak point in all these photographs is that there is nothing to show the difference in appearance between the two sides of the valve; the first four from the want of sufficient aperture in the lenses themselves, and the last two because the increased aperture has not been allowed to act owing to the stopping down of the sub-stage condenser. All the pictures are true enough as far as they go; the outer side of the valve, with the widest aperture of the lens, does give this appearance of white hexagons with dark interspaces, but when you examine the other side of the valve with the same aperture the appearances are exactly reversed, and you have dark hexagons with white interspaces. I wish it to be understood that I am using the word hexagons in a conventional sense only, for it is a question with me whether they have any real existence on any side of the valve. I have no doubt in my own mind that the structure on the outer side of the valve of *P. angulatum* is of exactly the same character as that on the corresponding side of *P. formosum*, and likewise consists of short bars of siliceous lengthways on the valve as the following examples will show.

The inner side of the valve seems to offer the greater difficulty of the two, owing to its being the more robust, and showing but few examples of torn structure; but lately I have found what may be considered a unit of structure for this side which should help us a little towards understanding its true meaning. To procure an appearance of dark fields with white interspaces when the inner side is uppermost, is purely a result of wide aperture, when the valve is mounted dry on the cover; but the shape of the fields will depend on how much of that aperture is utilized. With a small aperture of the condenser they conform to the appearance of the other side of the valve and are white; but when the aperture is enlarged sufficiently they assume the shape of dark rectangles. With full aperture of the dry condenser and bull's-eye they become hexagonal, and photographically the boundaries of the hexagons are often split up into six intercostals. I say photographically, for visually intercostals are not in evidence, or at least not to me, having spent two whole evenings trying to see them without doubt. Of course I have seen them, but every microscopist knows what that means when looking for some minute detail which he knows ought to be there, and imagination takes the place of actual vision.

The fact of not being able to see them ought not, however, to be conclusive evidence against their existence, when we consider within how minute a space all these subdivisions are contained—the whole structure in a blaze of light—and it is easy to suppose that the photographic plate is more sensitive to such minute differences in illumination than the eye would be. Still I am awake to the danger of trusting to appearances only when minute details are concerned, and remember that Mr. Nelson has shown us how in many cases intercostals are the result of the secondary spectra and that a wide-angled objective becomes a small one in relation to very minute structure. But while it may not be possible to determine from the appearances alone that the intercostals are real,

there is no evidence that they are not, and if we can derive this from another quarter in favour of their existence, I do not see why we should reject it. I think this evidence in favour of their truth is found in the fact that fractures occur at the point where the dark lines divide one from another, as we shall see by at least two examples from different valves.

I have called the appearances produced in my photographs, intercostals, but I may state that they differ from what has hitherto gone under that name, both in character and their mode of production. Having carefully examined the whole series from the Eichhorn pattern to those produced purposely by Mr. Nelson from *Triceratium favus* and the eye of the fly, I find that they all possess this common characteristic; that they seem to be miniature images of the centre spot, thrown off in a circle around it and are light or dark as that is; and that they are all the production of a small aperture. In mine, however, the centre is dark but the intercostals light, and the divisions between them are only shown with the widest aperture of an oil-immersion objective of at least 1.40 N.A. Two slides will well show this. In the first, taken with the condenser stopped down, there is no appearance of a division of the bars, while in the second are shown thin dark lines cutting them in two.

In the June number of the Journal of this Society for 1892, p. 428, there is a review of Dr. Van Heurck's work on the Microscope, where in speaking of test-objects the writer of the article says, 'What we now need are objects which will specially differentiate the qualities of the apochromatic objectives from their achromatic predecessors, especially when it is considered that for lined (or dotted) objects the table so long and usefully printed at the back of this Journal gives the theoretical power of any lens.'

Now, with all deference I submit that this evidence of the minute division of structure around the dark hexagons of the inner layer of *P. angulatum* is just the test-object required to fulfil this purpose, as far as oil-immersions are concerned, and one that proves at least that the apochromatic with which this structure was taken works to the theoretical limit of its aperture (1.40). Mr. Nelson has kindly worked out the measurements for me, and assuming the diameter of a hexagon to be  $1/50,000$  in., each side would be  $1/86,600$  in., and the intercostal itself  $1/173,200$  in. in diameter. Indeed, the diameter is considerably less than this, there being a space to divide one intercostal from another.

Unfortunately, while within the photographic, it is without the visual limit of the resolving power of the lens, and unless the aperture of the objective can be considerably increased by true monochromatic light, we cannot hope to see them. Of course, the dimensions given will depend upon the size of the hexagons being correct, but anyway the dividing up of the interspaces seems to point to a great advance of definition on any objective of pre-apochromatic days.

As to the nature of the structure, I consider that its unit consists of short bars of silex of the same character as that on the outer side of the valve, only much more minutely divided, and with sufficient aperture we should find them square instead of round.

Recurring to the question of the hexagons, I do not think that on



either side of the valve there is any even boundary of dividing bars to produce this figure, no matter how realistic the picture. We have seen from the photographs that on the outer side the appearance is produced by a swelling out of the bright patches when the focus is depressed, and on the inner it seems to be due to the short bars—or intercostals—being disposed around the dark fields in such a manner that the intermediate bars are set at an oblique angle to the top and bottom ones. On this question, however, I speak with all diffidence, as it seems to be one on which we require more light in the shape of N.A.”

Mr. Nelson said it became an interesting question, what were the conclusions which they must logically come to if these intercostals were realities? The matter was one which certainly required some further light, unless they were to experience an entire alteration of their opinions of the Abbe theory. By means of blackboard diagrams he then showed what ought to appear according to theory and what seemed to be seen in practice. He expressed his suspicion that there was probably some truth in each, and that it would be found that they had a very strong structure of 50,000 and a very slight structure of 100,000, and that as regarded the spectra they had really the six strongly shown, but the others were also to be detected very faintly outside.

Mr. J. E. Ingpen said he could quite corroborate what Mr. Nelson had said—speaking from memory as to a photograph of a diffraction grating which had strong lines well photographed, but owing to some circumstance there was a very faint indistinct line between them, apparently not capable of giving a spectrum.

Mr. T. Comber said he had been studying the structure of diatom-valves for some little time, and in one respect at least he could confirm what Mr. Smith had said, for he believed that all the specimens of *Pleurosigma* had valves consisting of two layers. He had brought with him two photographs to show the existence of these two layers, as they could there be very clearly seen, the one projecting beyond the other. The other parts mentioned in Mr. Smith's paper he had not been able to see himself, although he had tried his best to do so. Mr. Smith said that they could not be seen in the case of diatoms mounted in styrax or other highly refractive media—but that he could see them in specimens mounted dry. He thought if this was so, they were very likely to reach conclusions which might be very misleading, supposing that diatoms believed to be dry became damp—as they were very apt to do.

The thanks of the meeting were voted to Mr. Smith for his communication and exhibition.

The President said it would no doubt be remembered that some time ago the Society sent to the Chicago Exhibition some very beautiful photomicrographs supplied by Mr. Nelson, Mr. White, and Mr. Pringle. He believed that these exhibits had obtained a medal; and though they had at present received no official intimation of the fact, the news had come to them in a way which was so thoroughly characteristic of their friends on the other side of the water, that they might like to hear the communication read.

Dr. Dallinger then read the circular, greatly to the amusement of the Fellows present.



The President reminded the meeting that as the next would be the Annual Meeting of the Society, it was necessary to nominate those who were to be elected as Officers and Council for the ensuing year. He accordingly read the list of those recommended by the Council, as follows:—

As *President*—Albert D. Michael, Esq., F.L.S.

As *Vice-Presidents*—Prof. Lionel S. Beale, M.B., F.R.C.P., F.R.S.; Robert Braithwaite, Esq., M.D., M.R.C.S.; Frank Crisp, Esq., LL.B., B.A., V.P. and Treas. L.S.; Thomas H. Powell, Esq.

As *Treasurer*—William Thomas Suffolk, Esq.

As *Secretaries*—Prof. F. Jeffrey Bell, M.A.; Rev. W. H. Dallinger, LL.D., F.R.S.

As *Members of Council*—Alfred W. Bennett, Esq., M.A., B.Sc.; Rev. Edmund Carr, M.A., F.R.Met.S.; Edward Dadswell, Esq.; Charles Haughton Gill, Esq., F.C.S.; Richard G. Hebb, Esq., M.A., M.D., F.R.C.P.; George C. Karop, Esq., M.R.C.S.; Edward Milles Nelson, Esq.; Prof. Urban Pritchard, M.D.; Charles F. Rousselet, Esq.; Prof. Charles Stewart, Pres. L.S.; John Jewell Vezey, Esq.; Thomas Charters White, Esq., M.R.C.S., L.D.S.

The President said it would be necessary also to elect two Fellows as Auditors of the Society's accounts, which would have to be presented at the Annual Meeting. On behalf of the Council he appointed Mr. E. Dadswell as one Auditor, and he asked the Fellows to elect another on behalf of the Society.

Mr. J. J. Vezey was thereupon proposed by Mr. Ingpen, seconded by Mr. C. F. Rousselet, and unanimously elected.

Formal notice was then given by the President that the Annual Meeting of the Society would be held on January 17th, at 8 p.m.

The following Instruments, Objects, &c., were exhibited:—

Mr. J. W. Gifford:—Coloured Screens illustrating his paper.

Mr. J. W. Lovibond:—Coloured Screens.

Mr. E. M. Nelson:—New Model of a Microscope; Metal Chimney for a Microscope Lamp.

Mr. B. W. Priest:—*Arachnoidiscus ornatus* on Coralline, Mauritius.

Mr. C. F. Rousselet:—Mounted Rotifers.

Dr. W. N. Sherman:—Photomicrographs of *Trichina spiralis*, and Blood-corpuscles.

Mr. T. F. Smith:—Lantern Exhibition.

New Fellows:—The following were elected *Ordinary* Fellows:—Dr. Martin L. Belsler, Dr. Augustus Walter Reed, and Mr. Gerald Sturt.

ANNUAL MEETING, HELD 17TH JANUARY, 1894, AT 20 HANOVER SQUARE, W.  
THE PRESIDENT (A. D. MICHAEL, ESQ., F.L.S.) IN THE CHAIR.

The Minutes of the Meeting of 20th December last were read and confirmed, and were signed by the President.

The List of Donations (exclusive of exchanges and reprints) received since the last meeting was read, and the thanks of the Society were voted to the donors.

	From
Annual Report of the Geological Survey of Canada. Vol. v., 1890-1. (8vo, Ottawa, 1893) .. .. .	<i>The Survey.</i>
Ninth Annual Report of the Bureau of Ethnology, 1887-8. (8vo, Washington, 1892) .. .. .	<i>The Smithsonian Institution.</i>
R. Braithwaite, The British Moss Flora. Part xv. (4to, London, 1893) .. .. .	<i>The Author.</i>

Prof. F. Jeffrey Bell then read the Annual Report of the Council for the past year as follows:—

#### REPORT OF THE COUNCIL FOR 1893.

*Fellows.*—During the year 1893, 37 new Fellows, or distinctly more than the average of the last two years, were elected, whilst 12 have died and 27 resigned; the number of resignations is therefore declining.

One Honorary Fellow, Prof. Oscar Hertwig of Berlin, the distinguished embryologist, was elected in place of Prof. Herman Fol, who is believed to have been lost at sea.

Among the Ex-officio Fellows who have died, the Council regret to find the name of Prof. Milnes Marshall, President of the Manchester Microscopical Society, one of the editors of the 'Quarterly Journal of Microscopical Science.'

The List of Fellows now contains the names of 620 Ordinary, 1 Corresponding, 50 Honorary, and 86 Ex-officio; or a total of 757.

*Finances.*—It is with extreme regret that the Council have to report that the annual income from subscriptions is considerably below that of many previous years. The Council earnestly impress upon the Fellows the great necessity for a prompt payment of the annual fees, as the Society has to depend principally upon this source of income for the means to meet their very heavy expenses. Had the full amount of subscriptions due for 1893 been duly paid, the Society's income from this source would have been almost 20 per cent. more than it actually was.

The Council have great pleasure in announcing that the amount obtained by the sale of the Journal continues to increase. They received from their publishers 342*l.* 9*s.* 10*d.*, as against 361*l.* 12*s.* 4*d.* paid in the previous year; but of this latter sum 48*l.* 15*s.* was overpaid in 1892, and would otherwise have been received this year. The real increase for 1893 is therefore 78*l.* 7*s.* 6*d.* over that of last year.

*Rooms.*—The Council note with regret that the Fellows appear to take but slight advantage of the arrangement by which the Library is open on Wednesday evenings; they trust that by calling the attention

of the Fellows to the convenience that is thus afforded them, they may make the knowledge of the fact more widely spread.

*Library.*—The circulation of books to Fellows has considerably increased during the past year; and the Council hope that when the Catalogue is published, referred to in last year's Report, the value of the Library will be further increased to the Fellows; they have to report that a beginning has been made with a subject Catalogue, which ought to be, when completed, of immense advantage.

*Instruments and Apparatus.*—A rough inventory of the Society's instruments has been prepared, and the Council will be glad to receive information from the Fellows as to the past history of many of the instruments. They hope when the inventory is made more complete to issue it to the Fellows.

*Journal.*—A consideration of the state of the Society's finances led the Council last year to request the Editor to diminish the size of the December number of the Journal, and to do his best to keep the Journal within more moderate limits; this request has been faithfully attended to, and the Council hope that no further reductions will be found necessary; but they can only permit the abstracts in the Journal to be as full, and the illustrations to be as numerous as they have been in the past, if the income of the Society be kept up to its old standard by the punctual payment of the Annual Subscriptions of the Fellows.

The communications printed in the Transactions, which were 12 in 1892, and 11 in 1891, were 13 in 1893; slight as the increase is, the Council are glad to note an increase instead of a decrease in the memoirs presented to the Society.

Some idea of the extent of information given in the Journal last year may be gathered from the fact that the number of references in the Indices amount to more than 4800.

Mr. J. J. Vezey said he had much pleasure in moving the adoption of the Report which had just been read; he thought it showed that the Society was in a satisfactory condition, although it appeared to have shared in the general financial depression of the year.

Mr. F. W. Hembrey having seconded the motion,

The President put it to the meeting and declared it to be carried unanimously.

---

The Treasurer (Mr. W. T. Suffolk) then read his Statement of Account for the year 1893, and submitted the Balance Sheet duly certified by Mr. E. Dadswell and Mr. J. J. Vezey, the Auditors appointed at the preceding meeting.

The President said that they could hardly regard the Treasurer's Report as being otherwise than satisfactory, although their balance in hand was not so large as it might have been owing to the large number of subscriptions which seemed to be in arrear; this matter would, however, no doubt receive the attention of those whom it concerned. He had great pleasure in moving that the Treasurer's Report be received and adopted. This motion having been put from the chair was carried unanimously.

---

## THE TREASURER'S ACCOUNT FOR 1893.

Dr.

Cr.

1893.		1892		1893.			
	£	s.	d.		£	s.	d.
To Balance brought from 31st December, 1892	..	..	108 13 9	By Rent, Coals, and Attendance	..	..	133 14 0
" Interest on Investments	..	..	81 5 10	" Salaries, Reporting, and Commission	..	..	143 13 6
" Admission Fees	..	..	71 8 0	" Books and Binding	..	..	88 2 0
" Annual Subscriptions	..	..	787 6 0	" Expenses of Journal	..	..	940 0 4
" Sale of Journal	..	..	342 9 10	" Postage of Journal	..	..	28 7 2
" Advertisements	..	..	38 1 0	" Reprints of Papers	..	..	3 12 9
" Reprints sold	..	..	14 4 2	" Stationery and Miscellaneous Printing	..	..	23 12 7
" Catalogues sold	..	..	0 7 0	" Refreshments	..	..	11 17 6
" Woodblocks sold	..	..	2 1 8	" Fire Insurance	..	..	1 10 0
" Tools sold	..	..	0 9 0	" Petty Cash	..	..	35 5 9
			<u>£1446 6 3</u>	" Balance remaining 31st December, 1893	..	..	£1409 15 7
							<u>£1446 6 3</u>

## Investments, 31st December, 1893.

1200*l.* Freehold Mortgages. 780*l.* 17*s.* 3*d.* India Three per Cents. (including 100*l.* Quekett Memorial Fund).W. T. SUFFOLK, *Treasurer.*

The foregoing Account examined and found correct.

J. J. VEZEY,  
EDWARD DADSWELL, } *Auditors.*



The President said that their next business would be to elect Officers and Council for the ensuing year, and for this purpose he appointed Mr. J. M. Allen and Mr. F. W. Hembrey to act as Scrutineers on the occasion, and the ballot was at once proceeded with.

The Scrutineers having handed in their Report,

The President declared that the whole of the gentlemen whose names had been printed upon the balloting papers were duly elected to serve as Officers and Council during 1894 as under :—

*President*—Albert D. Michael, Esq., F.L.S.

*Vice-Presidents*—\*Prof. Lionel S. Beale, M.B., F.R.C.P., F.R.S.; Robert Braithwaite, Esq., M.D., M.R.C.S.; Frank Crisp, Esq., LL.B., B.A., V.P. and Treas. L.S.; \*Thomas H. Powell, Esq.

*Treasurer*—William Thomas Suffolk, Esq.

*Secretaries*—Prof. F. Jeffrey Bell, M.A.; Rev. W. H. Dallinger, LL.D., F.R.S.

*Twelve other Members of Council*—Alfred W. Bennett, Esq., M.A., B.Sc.; Rev. Edmund Carr, M.A., F.R.Met.S.; Edward Dadswell, Esq.; Charles Haughton Gill, Esq., F.C.S.; Richard G. Hebb, Esq., M.A., M.D., F.R.C.P.; George C. Karop, Esq., M.R.C.S.; Edward Milles Nelson, Esq.; Prof. Urban Pritchard, M.D.; \*Charles F. Rousselet, Esq.; \*Prof. Charles Stewart, Pres. L.S.; \*John Jewell Vezey, Esq.; Thomas Charters White, Esq., M.R.C.S., L.D.S.

The President then read his Annual Address.†

Dr. R. Braithwaite, in moving a hearty vote of thanks to the President for the very admirable address to which they had just had the pleasure of listening, said he felt sure that all who were present must agree that it had afforded a confirmation of his opening remarks that no amount of oratory could have satisfactorily replaced the extremely interesting description of facts of which this address so largely consisted. The wonderful way in which these minute creatures were adapted to the conditions under which they existed, and the extraordinary care and skill with which the President had followed out his observations were most remarkable, and there was, he believed, no one else either in this country or, perhaps, even in Europe, whose knowledge of the subject was greater.

Mr. T. C. White said he should be very proud to second this vote of thanks to the President for his address; he felt sure that the name of Mr. Michael would be associated for ever and ever with the Acari. They had not only his monumental work on the Oribatidæ but they found he was still carrying on his researches with the successful results which had been laid before them. This work was one which evidenced in a surprising manner the delicacy of manipulation acquired so as to be able to undertake the dissection of these mites, and to cut a series of sections of them. The great interest which Mr. Michael had thrown around the subject, not only in this address, but by the record of all that he had previously done, would, he hoped, be the means of inducing many others to take up the subject for themselves.

\* Those with an asterisk (\*) have not held during the preceding year the office for which they were nominated.

† See *ante*, p. 18.

Dr. Braithwaite having put his motion to the meeting, it was carried by hearty acclamation.

The President said that at so late an hour of the evening he would not respond at any length to the extremely kind remarks of the mover and seconder of this resolution, but would only thank the Fellows present for the very cordial manner in which they had passed this vote of thanks.

Mr. J. J. Vezey thought they would not be doing their duty if they allowed the meeting to close without expressing their thanks to the Treasurer, Secretaries, and other Officers of the Society for their services during the past year. When they remembered the efficient way in which these gentlemen had discharged their duties, their unflagging energies and courtesy to all with whom they came in contact, he was sure it would be felt that the best thanks of the Society were due to them. He therefore had great pleasure in proposing that this should be done.

The President hoped he might be allowed to second this proposal, knowing so well as he did how deeply the Society was indebted to its Council and Officers for the attention which they had given to its affairs during the year. Having put the resolution to the meeting, it was carried unanimously, amidst considerable applause.

Prof. Bell said he thought that the most important of the Officers of the Society was the Treasurer, on whom, had he still been present, he should have called to reply; but if the duty did not lie with him, it had always been recognized as the office of the Junior Secretary to respond to such a vote of thanks. He suggested that the cause of the absence of Dr. Dallinger that evening might be due to his anxiety to escape that ordeal. But, however that might be, he had himself been thinking if it might not be possible that the falling off in their balance, and the large number of subscriptions which were in arrear, might not after all be in some way due to the fact that the Senior Secretary had been too long in office—he would just throw this out as a suggestion. Really, however, he hardly thought that they deserved all the kind things which had been said of them, for, after all, the work was not very great, considering how cheerfully they were assisted by the Fellows of the Society; and it was some pleasure to serve a Society where so much interest was taken in the proceedings, and the meetings of which were far better attended than was the case with those of many other Societies whose membership was much larger. Of course, it would be obvious that they could not do everything from that side of the table, but with the co-operation of the Fellows of the Society they would spare no effort to make the meetings as interesting in the future as they had been in the past.

---

**New Fellows:**—The following were elected *Ordinary* Fellows:—Mr. Frederick William Watson Baker, Dr. William A. Campbell, Mr. Arnold W. Cooper, Mr. Henry T. Pease, Lieut.-Colonel Henry George Fombelle Siddons, R.A.

JOURNAL  
OF THE  
ROYAL MICROSCOPICAL SOCIETY.

APRIL 1894.

TRANSACTIONS OF THE SOCIETY.

III.—*The Foraminifera of the Gault of Folkestone.*—V.\*

By FREDERICK CHAPMAN, F.R.M.S.

(Read 18th October, 1893.)

PLATES III. AND IV.

*Sub-family NODOSARIINÆ—continued.*

LINGULINA d'Orbigny [1826].

*Lingulina nodosaria* Reuss (plate III. fig. 1 a, b).<sup>1</sup>

*Lingulina nodosaria* Reuss, 1862, Sitzungsber. d. k. Ak. Wiss. Wien, vol. xlv. p. 59, plate v. fig. 12 a, b. *L. nodosaria* Berthelin, 1880, Mém. Soc. géol. France, sér. 3, vol. i. No. 5, p. 64, plate iv. fig. 10.

This species has been recorded from beds of Neocomian age in North Germany (Reuss), and also from the French Gault (Berthelin).

EXPLANATION OF PLATES.

PLATE III.

- |              |   |       |
|--------------|---|-------|
| Fig. 1 a, b. | — <i>Lingulina nodosaria</i> Reuss.             | × 60. |
| 2 a, b.      | — <i>semiornata</i> Reuss.                      | × 60. |
| 3 a, b.      | — <i>dentilocarinata</i> sp. n.                 | × 60. |
| 4 a, b.      | — <i>Fronidicularia</i> <i>Loryi</i> Berthelin. | × 60. |
| 5 a, b.      | — <i>Archiaciana</i> d'Orbigny.                 | × 60. |
| 6.           | — <i>gaultina</i> Reuss.                        | × 60. |
| 7.           | — <i>inversa</i> Reuss.                         | × 45. |
| 8.           | — <i>pinnæformis</i> sp. n.                     | × 30. |
| 9, 10, 11.   | — <i>Karveri</i> Berthelin sp.                  | × 30. |
| 12.          | — <i>strigillata</i> Reuss.                     | × 30. |
| 13, 14.      | — <i>lanceola</i> Reuss.                        | × 30. |
| 15.          | — <i>Ungeri</i> Reuss.                          | × 60. |
| 16.          | — <i>Parkeri</i> Reuss.                         | × 60. |
| 17.          |   |       |

PLATE IV.

- |              |  |       |
|--------------|--|-------|
| Fig. 1 a, b. | — <i>Fronidicularia planifolium</i> sp. n. | × 45. |
| 2.           | — <i>Guestphalica</i> Reuss.               | × 30. |
| 3.           | — <i>microdiscus</i> Reuss.                | × 32. |
| 4.           | — <i>quadrata</i> sp. n.                   | × 30. |

\* For Part IV. see this Journal, 1893, p. 579.

In the Folkestone-Gault collection it is represented by a single specimen only, from zone v.

*Lingulina semiornata* Reuss (plate III. figs. 2 a, b, 3 a, b).

*Lingulina semiornata* Reuss, 1862, tom. cit., p. 91, plate xii. fig. 11.

This species was first described by Reuss from the Gault of Folkestone in the paper above quoted, and it has been subsequently recorded from the Gault of France by Berthelin. I have also found one specimen in the Chalk-Marl of Eastwear Bay, Folkestone. The shell usually possesses seven chambers, as noted by Reuss, though one specimen in my collection has only four, and another, which is figured, has eight chambers. The two specimens figured are the varieties that can be easily recognized in the Gault series, and may represent differences referable to "dimorphism." This species is by no means a common one in the Gault, but is nevertheless fairly well distributed through the formation. It is found in zone i., specimen b, very rare; zone iii., very rare; zone v., very rare; zone vi., very rare; zone x., very rare; zone xi., 55 ft. from the top, very rare; 50 ft., very rare; 45 ft., frequent; 40 ft., very rare; 35 ft., rare; 30 ft., rare; 25 ft., frequent.

FRONDICULARIA DeFrance [1824].

*Frondicularia Loryi* Berthelin (plate III. fig. 5 a, b).

*Frondicularia Loryi* Berthelin, 1880, Mém. Soc. Géol. France, sér. 3, vol. i. No. 5, p. 60, plate iv. fig. 5.

This species and the one next to be described may be regarded as links between the genera *Lingulina* and *Frondicularia*; but since their chambers are decidedly chevroned, they can more reasonably be assigned to the latter genus. *F. Loryi* has been recorded from the

PLATE IV.—continued.

- Fig. 5 a, b. *Frondicularia perovata* sp. n. × 30.  
 " 6. " *Cordai* Reuss. × 45.  
 " 7.—*Flabellina didyma* Berthelin sp. × 60.  
 " 8 a, b.—*Rhabdogonium tricarinatum* Reuss, var. *acutangulum*  
 Reuss var. × 60.  
 " 9 a, b. " *exoovatum* Reuss. × 60.  
 " 10 a, b. " *Maertensi* Reuss. × 60.  
 " 11 a, b.—*Marginulina glabra* d'Orbigny. × 50.  
 " 12. " *inæqualis* Reuss. × 65.  
 " 13 a b. " *hamulus* sp. n. × 60.  
 " 14. " *linearis* Reuss. × 60.  
 " 15. " *debilis* Berthelin. × 60.  
 " 16, 17. " *Folkestoniensis* sp. n. × 60.  
 " 18. " *aspera* sp. n. × 60.  
 " 19. " *tenuissima* Reuss. × 60.  
 " 20. " *æquivoca* Reuss. × 60.  
 " 21. " *striatocostata* Reuss. × 60.  
 " 22. " *Munieri* Berth. × 60.  
 " 23. " *robusta* Reuss. × 50.  
 " 24. " *Jonesi* Reuss. × 60.



French Gault; and in the Gault of Folkestone it was found at one horizon only, zone vii., one specimen.

*Frondicularia denticulocarinata* (plate III. fig. 4 *a, b*).

Shell elongate; somewhat compressed, but swollen interruptedly along the central axis; sides denticulo-carinate. The shell tapers slightly towards the aboral end, and consists of from six to nine chambers, denticulate at their extremities; the sutural lines arched, and the chambers impressed in the lower third, above which is an inflated portion. The primordial chamber is spheroidal, and the earlier segments are greater in breadth than height, but rapidly become equal; the aperture a simple slit. Length of the longest specimen 1/33 in. This elegant form was found in the Gault of Folkestone in zone x., very rare; zone xi., 55 ft. from the top, very rare; 40 ft., very rare; 35 ft., very rare.

*Frondicularia Archiaciana* d'Orbigny (plate III. fig. 6).

*Frondicularia Archiaciana* d'Orbigny, 1840, Mém. Soc. Géol., France, vol. iv. p. 20, plate i. figs. 34-6. *F. Archiaciana* Reuss, 1845, Verstein. böhm. Kreidef., pt. i. p. 31, plate xiii. fig. 29. *F. Archiaciana* Burrows, Sherborn and Bailey, 1890, Journ. Roy. Micr. Soc., p. 558, plate X. fig. 6 *a, b*.

The Folkestone specimen resembles more closely Reuss's figure than d'Orbigny's, as the former has striations on the shell-surface. This species has been recorded from the Chalk of Meudon, &c. (d'Orbigny); the Chalk of Kent and Chalk-detritus of Charing (Rupert Jones); the Chalk of the North of Ireland (Wright); the Chalk of Bohemia and Westphalia (Reuss); and from the Red Chalk of Speeton (Burrows, Sherborn and Bailey). In the Folkestone Gault, zone i., specimen *b*, one specimen.

*Frondicularia gaultina* Reuss (plate III. fig. 7).

*Frondicularia gaultina* Reuss, 1860, Sitzungsber. d. k. Ak. Wiss. Wien, vol. xl. p. 194, plate v. fig. 5. *F. gaultina* Burrows, Sherborn and Bailey, 1890, Journ. Roy. Micr. Soc., p. 558, plate X. fig. 5.

This species is occasionally met with in the Folkestone Gault, but is by no means common. It was found by Reuss in the *Mimimus*-clay of the Rhine; it also occurs in the Red Chalk of Speeton (Burrows, Sherborn and Bailey). It is found in the Gault in zone i., specimen *a*, very rare; zone v., very rare; zone x., rare.

*Frondicularia inversa* Reuss (plate III. fig. 8).

*Frondicularia inversa* Reuss, 1845, Verstein. böhm. Kreidef., pt. i. p. 31, plate viii. figs. 15-19; plate xiii. fig. 42.

The Folkestone specimens resemble the broader figures of Reuss's species, and the form is very confined in its range in the Gault. It has been found in the Bohemian Chalk (Reuss); the Chalk-Marl of

Dover and Charing, and the Gault of Kent (Rupert Jones). This species is found in zone x., frequent.

*Fronidicularia pinnæformis* (plate III. figs. 9, 10, 11).

[In the Gault series of *Fronidulariæ* numerous examples occur of a two-ribbed species, which is perhaps somewhat closely allied to *F. inversa* and *F. hastata* Röm. It seems necessary, however, to treat our species as distinct, since it is always characterized by the two superficial ribs, and the form also occupies a prominent place among the Gault Foraminifera. Prof. T. Rupert Jones has already made MS. notes of this form, which he noticed many years ago, and he has with great generosity allowed me to make full use of his MS.]

Shell elongate, acutely oval, more strongly compressed at the ends than at the centre; tapering to an obtuse point at the distal end; the aboral end acuminate. Chambers numbering from five to sixteen, finely striate or smooth, slightly convex, forming acute angles, the limbs of the last three or four extending to within one-half of the entire length of the shell. The edge of the shell in the earlier half rounded, afterwards more or less square. Two sharply-edged longitudinal ridges occupy the central surface, wider apart at the distal than at the aboral end. Length 1/40–1/10 inch.

One of the specimens here figured has the primordial chamber singularly like that of *Nodosaria bactroides*. A species of *Fronidularia* has been recorded from the Phosphate beds of Cambridge\* by G. R. Vine as "*Fronidularia* var. with two parallel longitudinal ribs," which is evidently the same as *F. pinnæformis*. This species is found in the Gault of Folkestone in zone ix., rare; zone x., very common; zone xi., 55 ft., from the top, common; 45 ft., common; 40 ft., rare; 35 ft., very rare; 30 ft., frequent; 25 ft., rare.

*Fronidularia Karreri* Berthelin sp. (plate III. fig. 12).

*Flabellina Karreri* Berthelin, 1880, Mém. Soc. géol. France, sér. 3, vol. i. No. 5, p. 62, plate iv. figs. 1–3.

This species is here placed in the genus *Fronidularia* since the irregular development of the commencing series of chambers is by no means *Cristellarian*; that is, the unequal increase in size of one or other side of the shell produces no marked tendency to a curved axis of growth. This species evidently bears some affinity towards *F. pinnæformis*, but in *F. Karreri* the longitudinal or radial ribs are not so prominent and are more numerous and irregular. It has previously been recorded from the French Gault. It is found at Folkestone in zone v., frequent; zone vii., common; zone viii., very rare; zone x., very rare; zone xi., 55 ft., from the top, rare; 45 ft., very rare.

\* Proc. Yorks. Geol. and Polyt. Soc., xi. p. 273.

*Frondicularia strigillata* Reuss (plate III. figs. 13 and 14).

*Frondicularia strigillata* Reuss, 1860, Sitzungsab. d. k. Ak. Wiss. Wien, vol. xl. p. 195, plate vi. fig. 3.

This species is an exceedingly variable one in the Folkestone series. Few of the specimens exactly resemble Reuss's figure, but the feeble appearance of the nuclear chamber and the interrupted strigillate ornamentation tend to clear away any doubt as to their identity. In some specimens one side of the shell is developed almost wholly at the expense of the other. Reuss's Cretaceous specimens were obtained from detrital sand of Westphalia. In the Gault it is found in zone vi., very rare; zone vii., very rare; zone x., very rare; zone xi., 55 ft. from the top, frequent; 45 ft., very rare.

*Frondicularia lanceola* Reuss (plate III. fig. 15).

*Frondicularia lanceola* Reuss, 1860, tom. cit., p. 198, plate v. fig. 1.

The Gault specimen does not exactly agree with Reuss's figure since it has the aboral end of the shell abnormally developed or sub-*Flabelline*; but there is no doubt of its affinity with this species. Reuss's specimens are recorded from the Lower Senonian marl of Westphalia. One specimen only was found in the Gault, in zone xi., 20 ft. from the top.

*Frondicularia Ungerii* Reuss (plate III. fig. 16).

*Frondicularia Ungerii* Reuss, 1862, Sitzungsab. d. k. Ak. Wiss. Wien, vol. xlvi. p. 54, plate iv. fig. 11 *a, b*. *F. Ungerii* Berthelin, 1880, Mém. Soc. géol. France, sér. 3, vol. i. No. 5, p. 61, plate iv. fig. 4.

This species has been recorded from the *Minimus*-clay of North Germany (Reuss) and from the French Gault (Berthelin). In the Gault of Folkestone it is a well-distributed form; and though clearly the same species as that figured by Reuss, it varies considerably, in a long series of specimens, in regard to the number of its chambers. At Folkestone it is found in zone v., very rare; zone vii., very rare; zone ix., common; zone xi., 55 ft. from the top, rare; 45 ft., rare; 40 ft., frequent; 35 ft., common; 30 ft., frequent; 25 ft., rare; 20 ft., rare; 12 ft., rare; 6 ft., frequent.

*Frondicularia Parkeri* Reuss (plate III. fig. 17).

*Frondicularia Parkeri* Reuss, 1862, Sitzungsab. d. k. Ak. Wiss. Wien, vol. xlvi. p. 91, plate xii. fig. 7.

This species was originally described by Reuss from the Folkestone Gault, and I have also met with it in the Gault of Godstone, Surrey. At Folkestone it occurs in zone v., rare; zone vi., rare; zone vii., rare; zone ix., very rare; zone x., common; zone xi., 55 ft. from the top, rare; 50 ft., rare; 45 ft., frequent; 40 ft., very rare; 20 ft., very rare; 6 ft., very rare.

*Frondicularia planifolium* (plate IV. fig. 1 a, b).

Shell ovate, pointed at the ends, the outline undulated; very thin, and with surfaces quite flat; the primordial chamber small, sub-oval, and with a central costa; chambers numerous, often as many as thirteen. The surface of the shell sometimes faintly striate. Length  $1/18$  in.

This elegant species can be distinguished from the nearly allied *F. Guestphalica* by its thinness and its possessing a smaller and more spherically shaped initial chamber.

*F. planifolium* is found at Folkestone in zone vi., very rare; zone vii., rare; zone x., rare.

*Frondicularia Guestphalica* Reuss (plate IV. fig. 2).

*Frondicularia Guestphalica* Reuss, 1860, Sitzungsb. d. k. Ak. Wiss. Wien, vol. xl. p. 195, plate vi. fig. 2.

The specimens which were described by Reuss were obtained from the *Minimus*-clay of Westphalia. The initial chamber of this species is usually more lanceolate than that of the other species of Gault *Frondiculariæ*. It is found at Folkestone in zone xi., 20 ft. from the top, frequent; 12 ft., very rare.

*Frondicularia microdiscus* Reuss (plate IV. fig. 3).

*Frondicularia microdisca* Reuss, 1860, Sitzungsb. d. k. Ak. Wiss. Wien, vol. xl. p. 195, plate v. fig. 4.

This species was described from the Cretaceous detrital sand of Hamm in Westphalia, and from the Gault of Folkestone (Reuss). One of the Gault specimens in my collection is feebly costulate. This species is found at Folkestone in zone x., rare; zone xi., 20 ft. from the top, very rare.

*Frondicularia quadrata* (plate IV. fig. 4).

Shell trapezoidal in outline, consisting of six chambers with obscurely-marked sutures; the nuclear chamber small, circular, slightly inflated, and surrounded by a carinate border; the edge of the shell square. The surface of the test traversed by about eight broken undulating costæ. Length  $1/20$  in.

This conspicuous form is represented by one specimen only, from the Gault, in zone x.

*Frondicularia perovata* (plate IV. fig. 5 a, b).

Shell of sub-oval form, pointed at the extremities, the edge grooved. Chambers from four to eight in number; the nuclear chamber inflated, but small; the others with convex surfaces. The limbs of the last two chambers embracing three-fourths of the length of the shell. Surface of the test sometimes faintly striate. Length  $1/16$  in., breadth  $1/24$  in.



The species here figured somewhat resembles Roemer's *F. ovata*; \* but the latter differs from it in the contour of the shell, which is more regularly ovate, and it also has more numerous, narrower, and shorter chambers. *F. perovata* is found at Folkestone in zone ix., very rare; zone xi., 50 ft. from the top, very rare; 45 ft., very rare; 12 ft., very rare.

*Frondicularia Cordai* Reuss (plate IV. fig. 6).

*Frondicularia Cordai* Reuss, 1844, Geogn. Skizzen aus Böhmen, vol. ii. p. 302. *F. Cordai* Reuss, 1845, Verstein. böhm. Kreideform., pt. 1, p. 31, plate viii. figs. 26-28; plate xiii. fig. 41.

This species is recorded from the Lower Plänerkalk and Plänermergel of Bohemia (Reuss); the Gault of Kent, the Chalk of Gravesend, and the Chalk-detritus of Charing (Rupert Jones in Morris' Catalogue); and from the Phosphatic beds of Cambridge (G. R. Vine). At Folkestone it is found in zone ii., specimen *b*, very rare; zone vii., very rare; zone ix., very rare; zone x., frequent; zone xi., 55 ft. from the top, rare; 50 ft., very rare; 45 ft., rare.

FLABELLINA d'Orbigny [1826].

*Flabellina didyma* Berthelin sp. (plate IV. fig. 7).

*Frondicularia didyma* Berthelin, 1880, Mém. Soc. Géol. France, sér. 3, vol. i. No. 5, p. 61, plate ii. fig. 18 *a, b*.

This species, which has been described by Berthelin from the Gault of Montelely, is especially interesting since it has a very neat, inflated *Cristellarian* commencement, whilst from the third chamber the ordinary *Frondicularian* form of growth is assumed. It is perhaps one of the simplest and most striking forms of *Flabellina* known to us, and, if we except the irregular, acuminate *Frondiculariæ*, the only species of the genus which is of Gault age. In the Chalk facies, however, *Flabellina* is prominent. In the Folkestone Gault this species is found in zone iii., very rare; zone v., very rare; zone vii., rare; zone ix., very rare; zone x., frequent; zone xi., 55 ft. from the top, common; 45 ft., frequent; 35 ft., very rare; 25 ft., very rare; 12 ft., rare; 6 ft., rare.

RHABDOGONIUM Reuss [1860].

*Rhabdogonium tricarinatum* d'Orbigny sp., var. *acutangulum*  
Reuss var. (plate IV. fig. 8 *a, b*).

*Rhabdogonium acutangulum* Reuss, 1862, Sitzungsber. d. k. Ak. Wiss. Wien, vol. xlvi. p. 55, plate iv. fig. 14. *R. tricarinatum* Burrows, Sherborn and Bailey, 1890, Journ. Roy. Micr. Soc., p. 558, plate x. fig. 7 *a, b*.

This variety is recorded from various strata in the Hils formation of North Germany (Reuss); and the Gault of France (Berthelin).

\* F. A. Roemer, 'Die Versteinerungen des norddeutschen Kreidgebirges' (1840-1), p. 96, pl. xv. fig. 9.

The specimen noted from the Red Chalk of Speeton (Burrows, Sherborn and Bailey) appears to belong to this variety. It occurs in the Gault of Folkestone in zone x., very rare; zone xi., 55 ft. from the top, very rare; 50 ft., very rare; 35 ft., very rare; 12 ft. common; 6 ft., very common.

*Rhabdognonium excavatum* Reuss (plate IV. fig. 9 a, b).

*Rhabdognonium excavatum* Reuss, 1862, tom. cit., p. 91, plate xii. fig. 8. *R. minutum* (?) Burrows, Sherborn and Bailey, 1890, Journ. Roy. Micr. Soc., p. 559, plate x. fig. 8 a, b.

This species has been found in the Gault of Folkestone (Reuss); the Gault of France (Berthelin); the Red Chalk of Speeton (Burrows, Sherborn and Bailey); and the Chalk of Ireland (Wright). It is the most ubiquitous species of *Rhabdognonium* in the Gault of Folkestone, and is found in zone x., common; zone xi., 55 ft. from the top, frequent; 50 ft., rare; 45 ft., frequent; 40 ft., rare; 35 ft., rare; 30 ft., rare; 25 ft., rare; 12 ft., very common; 6 ft., very common.

*Rhabdognonium Maertensi* Reuss (plate IV. fig. 10 a, b).

*Rhabdognonium Maertensi* Reuss, 1862, tom. cit., p. 56, plate v. fig. 4.

Reuss records this form from the Middle Hils-clay of Germany. At Folkestone one specimen only was found in zone ix.

#### MARGINULINA d'Orbigny [1826].

*Marginulina glabra* d'Orbigny (plate IV. fig. 11 a, b).

*Marginulina glabra* d'Orbigny, 1826, Ann. Sci. Nat., vol. vii. p. 259, No. 6;—Modèle, No. 55. *M. glabra* Brady, 1884, Chall. Rep., vol. ix. p. 527, plate lxxv. figs. 5, 6.

The smooth varieties of *Marginulina* from the Gault are a somewhat difficult series to separate. To the species *M. glabra* may be referred those examples which are nearly circular across the shell, and which have few and well-inflated chambers. It is, however, possible that the form next mentioned, *M. inæqualis* Reuss, may, after all, be a variety of the above, but with the initial series of chambers small, but subsequently increasing suddenly in size. Typical examples of *M. glabra* appear to be rare in the Folkestone Gault. It is recorded from the Red Chalk of Speeton (Burrows, Sherborn and Bailey); and altogether it is a well-distributed species in regard to geological time. Found in zone xi., 45 ft. from the top, very rare; 40 ft., very rare.

*Marginulina inæqualis* Reuss (plate IV. fig. 12).

*Marginulina inæqualis* Reuss, 1860, Sitzungsber. d. k. Ak. Wiss. Wien, vol. xl. p. 59, plate vii. fig. 3. *M. inæqualis* Reuss, 1862,

Sitzungsber. d. k. Ak. Wiss. Wien, vol. xlvi. p. 59, plate v. fig. 13; plate vi. fig. 8.

This form, which is more attenuate and irregular than *M. glabra*, was found by Reuss in the *Minimus*-clay of the Rhine, &c.; also from the French Gault (Berthelin), and from the Red Chalk of Speeton (Burrows, Sherborn and Bailey). In the Folkestone Gault it is found in zone iii., rare; zone iv., very rare; zone v., very rare; zone x., rare; zone xi., 40 ft. from the top, rare; 30 ft., very rare; 12 ft. rare.

*Marginulina hamulus* (plate IV. fig. 13 a, b).

Shell consisting of about seven chambers, the first five of which are very low in proportion to their breadth, the latter ones being about half as high as broad, and well-inflated. The general contour of the shell bears some resemblance to that of *M. inæqualis*, but it has the aboral pointed end bent into a sharper or hook-shaped curve. Length 1/48 in.

This form is found in the Folkestone Gault in zone i., specimen *b*, very rare; zone xi., 12 ft. from the top, very rare.

*Marginulina linearis* Reuss (plate IV. fig. 14).

*Marginulina linearis* Reuss, 1862, Sitzungsber. d. k. Ak. Wiss. Wien, vol. xvi. p. 60, plate v. fig. 15.

This species has been recorded by Reuss from the *Minimus*-clay of North Germany; and also from the French Gault (Berthelin). It is found at Folkestone in zone iii., frequent; zone xi., 30 ft. from the top very rare; 12 ft., very rare.

*Marginulina debilis* Berthelin (plate IV. fig. 15).

*Marginulina debilis* Berthelin, 1880, Mém. Soc. géol. France, sér. 3, vol. i. No. 5, p. 35, plate iii. fig. 28.

This very elegant species is a characteristic one in the Gault. It may possibly be a depauperated variety of *Nodosaria legumen* Reuss, with more marginally disposed apertures than is usually found in that species. This form is described by Berthelin from the Gault of France. At Folkestone it is found in zone iii., common; zone iv., very rare; zone v., common; zone vi., very rare; zone vii., very rare; zone x., very rare; zone xi., 55 ft. from the top, very rare; 50 ft., common; 45 ft., common; 35 ft., rare; 30 ft., very rare; 25 ft., rare.

*Marginulina Folkestoniensis* (plate IV. figs. 16 and 17).

The shell consists of from 3-7 chambers or more in the example found, arranged in a slightly curved line, well-inflated, and with the sutures deeply marked; the initial chamber is globose, and with a sharp spike. The surface of the shell is decorated with a few fine longitudinal costæ, generally more strongly developed towards the proximal portion of each segment, and sometimes bridging the sutural line. Length 1/55 to 1/24 inch.

In the general contour of the shell this species resembles *M. soluta* Reuss, but that the latter has the surface of the shell quite smooth, and the aboral end is not mucronate. *M. Folkestoniensis* is found in zone v., very rare; zone x., very rare; zone xi., 50 ft. from the top, very rare; 35 ft., very rare; 25 ft., rare.

*Marginulina aspera* (plate IV. fig. 18).

The shell consists (in the specimen found) of two chambers, both flask-shaped and well inflated, the last chamber with a long-necked orifice. The surface of the shell is decorated with conspicuous prickles, not very thickly distributed. Length 1/60 inch.

This species is similar in the decoration of the surface of the shell to *M. armata* Reuss,\* but is distinguished from the latter by the great obliquity of the chambers. One specimen only, found in zone xi., 6 ft. from the top.

*Marginulina tenuissima* Reuss (plate IV. fig. 19).

*Marginulina tenuissima* Reuss, 1862, Sitzungsb. d. k. Ak. Wiss. Wien, vol. xlvi. p. 61, plate v. fig. 18; p. 92, plate xii. fig. 12 (*M. tenuissima* var. Reuss).

This species was recorded by Reuss from the *Minimus*-clay of North Germany, and the variety of the type was also recorded by that author from the Gault of Folkestone. There seems, however, no occasion to separate the two forms figured by Reuss, since the series of specimens from Folkestone now under discussion shows all gradations with regard to the relative height and breadth of the chambers of the shells, and the number of the fine riblets. This species is found at Folkestone in zone xi., 55 ft. from the top, very rare; 45 ft., very rare; 35 ft., very rare; 30 ft., very rare; 12 ft., very rare.

*Marginulina æquivoca* Reuss (plate IV. fig. 20).

*Marginulina æquivoca* Reuss, 1862, tom. cit., p. 60, plate v. fig. 17.

This species is probably the commonest of the Gault *Marginulina*, and is easily distinguished by the thinness and paucity of its costæ. It has been previously recorded from the *Minimus*-clay of North Germany (Reuss); and from the Gault clay of France (Berthelin). At Folkestone it seems most characteristic of the Lower Gault. It is found in zone i., specimen *b*, very rare; zone ii., specimen *a*, frequent; zone ii., specimen *b*, very rare; zone iii., very common; zone iv., very common; zone v., frequent; zone vi., very rare; zone vii., rare; zone viii., rare; zone ix., very rare; zone x., very rare; zone xi., 55 ft. from the top, very rare; 50 ft., very rare; 25 ft., very rare.

\* Sitzungsb. d. k. Ak. Wiss. Wien, 1860, xl. p. 209, pl. vii. fig. 7.



*Marginulina striatocostata*, Reuss (plate IV. fig. 21).

*Marginulina striatocostata* Reuss, 1862, tom. cit. p. 62, plate vi. fig. 2.

This species is recorded by Reuss from the Upper Hils formation near Brunswick. It is found at Folkestone in zone iii., very common; zone iv., very common; zone x., very rare; zone xi., 40 ft. from the top, very rare; 25 ft. very rare.

*Marginulina Munieri* Berthelin (plate iv. fig. 22).

*Marginulina Munieri* Berthelin, 1880, Mém. Soc. géol. France, sér. 3, vol. 1, No. 5, p. 33, plate 1, fig. 19 *a*, *b*.

This species is not a common one in the Folkestone series. It was first described from the French Gault (Berthelin). At Folkestone it is found in zone v., very rare; zone x., very rare; zone xi., 50 ft., very rare; 45 ft., frequent; 40 ft., frequent.

*Marginulina robusta* Reuss (plate IV. fig. 23).

*Marginulina robusta* Reuss, 1862, Sitzungsab. d. k. Ak. Wiss. Wien, vol. xlvi. p. 63, plate vi. figs. 5, 6.

This species has thick and rounded costæ, which is one of the characters that distinguish it from the foregoing.

*M. robusta* is recorded from the Upper Hils clay, the Speeton clay, and the *Tardefurcatus*-clay of North Germany (Reuss). At Folkestone it is found in zone i., specimen *a*, very rare; zone i., specimen *b*, very rare; zone ii., specimen *c*, very rare; zone v., very rare; zone x., rare; zone xi., 55 ft. from the top, frequent.

*Marginulina Jonesi* Reuss (plate IV. fig. 24).

*Marginulina Jonesi* Reuss, 1862, tom. cit., p. 61, plate v. fig. 19.

This species was originally described from the Upper Hils clay of Germany (Reuss). It is not uncommon in the Gault series. Possibly it is only an attenuated variety of species like *M. Munieri*. It is found at Folkestone in zone iii., frequent; zone xi., 55 ft. from the top, frequent; 50 ft., very rare; 45 ft., frequent; 40 ft., rare; 35 ft., rare; 30 ft., frequent; 25 ft., common; 12 ft., very rare; 6 ft., very rare.

---

## IV.—An Inexpensive Screen for Monochromatic Light.

By J. WILLIAM GIFFORD, F.R.M.S.

(Read 20th December, 1893.)

## PLATE V.

MONOCHROMATIC light for use with the Microscope may, as far as I know, be obtained in three different ways:—

- (1) By the use of a prism.
- (2) By an incandescent gas or vapour.
- (3) By means of a coloured screen.

The beautiful apparatus used and shown by Mr. Nelson some time since is an instance of the first. By this the rays proceeding from an incandescent, lime, or other radiant, after passing through a slit, are dispersed by a prism of glass, and by means of a second slit any portion desired may be selected from the spectrum and used for the purpose required. But this apparatus is expensive, and, unless a second prism be used with the second slit to recompose it, the light thus obtained, although good in practice, does not really produce a uniformly monochromatic field of view, that is to say, the illumination at any one point is not exactly the same as at any other point, and one side of the object in the microscopic field will be illuminated by light many wave-lengths behind that by which the other side is illuminated.

As an example of the second method I will refer to the light produced by burning metallic sodium or thallium, or a salt of either, in the flame of a Bunsen burner, using a suitable support. By this method I was enabled, two years ago, to resolve *Amphipleura pellucida* into distinct dots. But it is difficult to feed the flame continuously, so as to make this method available for photography, and the plates used have to be bathed in erythrosine or cyanine, or some other dye, in order to make them sensitive to these wave-lengths.

The third method, that of the coloured screen, is not subject, as far as I know, to any of these drawbacks, but, in the form in which it has hitherto been mostly used, that of the trough containing chrome-copper solution, either the light is insufficiently monochromatic, that is to say, the band seen in the spectrocope, when it is so examined, is

## EXPLANATION OF PLATE V.

Fig. 1.—Solar spectrum without screen.

- |      |   |   |
|------|---|---|
| " 2. | "   | with screen, malachite-green in aqueous solution, prolonged exposure. |
| " 3. | "   | yellow glass.   |
| " 4. | "   | malachite-green, glycerine and picric acid.                           |
| " 5. | "   | effect of 3 followed by 4.  |
| " 6. | —Podura scale $\times$ 960, by P. and L. 1/10 in. achromatic N.A. 1.5, with screen as in fig 4. |   |

too broad, or it lies among the rays less refrangible and less suitable for photography. There is also great loss of light.

While at work on the various aniline dyes in connection with their photographic effect on the salts of silver when these are exposed to the light of the solar spectrum, it came to my notice that the absorption spectrum of benz-aldehyde green, commonly known as malachite green, was a very remarkable one.

We have two very broad dark absorption bands (fig. 2), one which has for its centre a point slightly less refrangible than line D in the solar spectrum, and extending from about B to E, with an aqueous solution of mean strength. A second band, having G for its centre and extending from a position slightly more refrangible than F to the calcium lines  $H_1H_2$ . These absorption bands, to which I shall not again refer, leave us bands of light at three distinct points, viz. (1) From A to B, a narrow red band of low intensity; (2) from E to a little beyond F, a rather wider, intense band; (3) from  $H_1H_2$  to M, a feeble, invisible band, the position of which can only be ascertained photographically. The band of light from E to F is the one to which I wish more particularly to direct your attention. It is in this region of the spectrum that blue graduates into green, and we may imagine a central point in the band which is neither blue nor green.

Now by dissolving the dye in different liquids, the position of this blue-green band may be modified to a considerable extent. I need not dwell on the fact that in common with most substances in solution which show absorption phenomena, these bands, and especially that one with which we are most concerned, will be widened by further dilution with the *same* solvent. But by the use of *different* solvents the position of the blue-green band in the spectrum may, within certain limits, be so shifted that a line drawn through its centre shall occupy a place more refrangible, or less refrangible, as the case may be, and in this way, and by the addition of other substances, the red band, as shown in aqueous solution, may be considerably reduced in intensity, and the faint band in the ultra-violet entirely removed.

Thus, by solution in glycerin the blue-green band is narrowed and shifted, so that it almost exactly fills the space between E and F when a given thickness or strength of solution is used, and, although narrowed, it is much brightened. At the same time the red band becomes much fainter, so that even for purposes of focusing it may be neglected.

If glycerin-jelly be used for the solvent, the blue-green band occupies a place midway between that of the same band in aqueous and glycerin solutions, transmits almost as much light as glycerin, and photographs more rapidly.

A solution in cedar-oil may be made without great difficulty, and in this case the band is even less refrangible than in the case of glycerin, and broader, and there is slightly more light, less being lost by reflection from the glass surfaces in contact with it.

A crystal of picric acid may be added to all malachite-green solutions containing glycerin; this removes the band in the invisible violet entirely (fig. 4), but it must be borne in mind that this band is extremely faint, even when a quartz prism is used, and I have been unable to detect it after the light has passed through the Microscope; probably it will not pass balsam. It is rather difficult to add the picric acid, which is apt to throw down the dye, unless care is taken always to add the picric acid in crystals after the dye has all been dissolved and the solution filtered. With a flame or lime-light spectrum this band is hardly to be traced, and the picric acid is quite unnecessary. In any case both this and the red band may be entirely removed by passing the light through a blue-green glass, such as Messrs. Baker supply with their Microscope-lamp, and this may be useful for focusing with the aqueous solution where the red band is strong. After focusing, the blue-green glass may be removed.

Malachite-green may also be dissolved in plain collodion, or in balsam, or any white varnish, and in this form it gives the blue-green band, brilliant and narrow, almost identical with that given by the glycerin solution.

By the gradual addition of almost any acid to any of these solutions, the band may be moved down towards the red, until it finally coalesces with the red band and is lost. Except in this case, the blue-green band appears to be movable up and down the spectrum *pari passu* with the refractive index of the solvent used, and for photographic purposes a solution in absolute alcohol would be the most useful, were it not for the small amount of visual effect and consequent difficulty of focusing, the band then lying almost entirely on the more refrangible side of F. And were it not for this same difficulty, a still greater shifting towards the violet might be accomplished by the addition of a small quantity of cyanine.

Almost any of these solutions may be made of sufficient strength for mounting between two cover-glasses in a layer little thicker than one of them, or in shallow cells on a glass slip. There is considerable advantage in mounting between glass-covers, which may then be inserted in the substage condenser in place of a diaphragm, or may occupy a position on a rotating wheel of stops.

The advantages I venture to claim for malachite-green used in this way are as follows:—

- (1) It gives a field of view uniformly monochromatic.
- (2) There is more light than with chrome-copper solutions, and the light is more monochromatic if certain precautions are taken.
- (3) It need not be used in solution, but, if so used, a very thin stratum is sufficient, and no large troughs or bottles are necessary.
- (4) No bathing of plates in erythrosine, or cyanine, or phosphine N is necessary, an ordinary rapid plate being sufficiently sensitive in this part of the spectrum; in fact, more refrangible light cannot conveniently be used, or there would not be enough light to focus by.



Monochromatic light in this form is therefore well adapted for photography with powers from  $1/20$  in. to  $1/50$  in., which may thus do work little inferior to that with apochromatics, provided they are of corresponding aperture, and I do not think that these highest powers have yet been made apochromatic.

In conclusion, and although out of place here, I hope you will allow me to call attention to an advantage which might be gained by the use of malachite-green screens for colour-correct landscape photography. I need not refer at length to the well-known gap which remains in the spectrum impressed on a cyanine-bathed plate, and which lies between lines E and F, in the case of an unboiled, between E and D in the case of a boiled emulsion. By over-exposure this gap may be filled up, but to the detriment of the remainder of the spectrum. Instead of this, by using a suitable malachite-green screen after a preliminary exposure without a screen, the gap may in either case be filled without damage to the remainder, and the plate be very uniformly impressed by all rays of the solar spectrum from A to H, and further, if an ordinary yellow-brown glass screen be used for the preliminary exposure, a photographed spectrum very nearly identical with the visual spectrum may be obtained. The gap appears to me to be due to the colour of the gelatin, which absorbs less light of this refrangibility than of any other, the absorption of light by the gelatin possibly accentuating its action as a sensitizer. With erythrosin-bathed plates the same defect is noticeable, and I have always found landscapes taken with these or cyanine plates lacking in the greens. Possibly this application might also be useful for reproducing objects in their natural colours by the Lippmann method, but I have as yet made no experiments in this direction.

---

V.—On *Fucitrogus Rhodymenia*, a Gall-producing Copepod.

By G. S. BRADY, M.D., LL.D., F.R.S.

(Read 21st February, 1894.)

## PLATE V.

SOME time ago, Miss Ethel S. Barton described certain malformations or galls which she had found upon various marine algæ\*—*Rhodymenia palmata* Grev., *Ascophyllum nodosum*, and *Desmarestia aculeata* Lin.—and she was kind enough to send me specimens of some Entomostraca (Copepoda) which occurred in the cavities of the galls. Some of these belonged to well-known free-swimming species whose association with the galls must be looked upon as purely accidental, but there were others of an unknown type, and quite abnormal in structure, which I believe to be the active agents in the production of the *Rhodymenia* galls, and which I propose here to describe. In the outgrowths of *Ascophyllum*, Miss Barton records that she found numerous specimens of a nematoid worm, which Dr. de Man, of Middelburg, believed to be undescribed, and which is presumably the cause of the galls in that plant. It would appear, therefore, that there is a large and extremely interesting field open for investigation in this direction.

I have as yet had no opportunity of seeing the living animal of the *Rhodymenia* gall, and the few specimens sent to me by Miss Barton have not sufficed to render the structure altogether clear. An examination of the living animals would, doubtless, do much to elucidate many points which are now obscure. Yet, from what has been made out, I see little reason to doubt that the creature is a permanent inhabitant of the gall-cavity, and that the gall is probably produced by it. I have come to this conclusion for the following reasons:—First, the shape and generally degenerate condition, which are those characteristic of many parasitic Crustacea; secondly, the apparently suctorial character of the mouth; thirdly, the build of the mouth-organs, which approach more nearly those of some of the Ascidiicolous species than to any free-living forms; lastly, the absence of any appendages adapted for creeping or swimming.

As this species cannot be placed under any of the three sections (Gnathostomata, Pœcilostomata, Siphonostomata) which, following

## EXPLANATION OF PLATE V.

*Fucitrogus Rhodymenia*, magnified 110 diameters.

- a*, mandible. *b*, antennule. *c*, antenna.  
*d*, mandible-palp (?) *e*, maxilla-palp (?) *f*, maxilla (?)  
*g*, maxilliped with setæ (*h*) and tentacular cirri (*i*).  
*k*, papilla with genital aperture. *ll*, setæ.  
*ph*, pharynx. *st*, stomach.

\* "On the Occurrence of Galls in *Rhodymenia palmata* Grev.," Journ. of Botany, March 1891. "On Malformations of *Ascophyllum* and *Desmarestia*," Murray's Phycol. Memoirs, 1892.

M. Thorell, I have previously adopted, I propose to institute provisionally, for its reception, a new section *Choneostomata*.\* Further investigation will, doubtless, remove the many imperfections and omissions of the following description:—

## Order COPEPODA.

## Section CHONEOSTOMATA.

## Genus FUCITROGUS † g. n.

## FUCITROGUS RHODYMENIÆ sp. n. Plate V.

Length 0·5 mm. Body broadly ovate, widest in the middle, produced at the posterior extremity; showing little or no trace of segmentation. There is a well-marked pharynx and digestive cavity anteriorly, the boundaries of which are defined by distinct chitinous bands, and are corrugated behind, so as to form something like a gastric mill. The median portion of the digestive canal has not been traced, but there is a distinct anus in the middle line at the posterior extremity of the animal. The oral opening is situated in the middle of what appears to be a protrusible proboscis, and is probably suctorial: its margins are covered with minute cilia; immediately within the orifice, at each side, is a mandible composed of three strong and rather blunt teeth (*a*). There are two pairs of antennæ (*b*, *c*), each consisting of a single joint terminated by three or four setæ, and a little behind these is a pair of similar limbs (*d*) with stouter setæ, which may, perhaps, be looked upon as mandible-palps. Considerably behind these, and about on a level with the hinder portion of the gastric cavity, are the two most conspicuous appendages, each consisting of a large triangular, chitinous base, to the distal end of which is attached (*f*) a group of five stout fusiform processes (somewhat like miniature fir-cones), which are beset on all sides with slender lateral setæ; four of these processes are of about equal length, but the distal process is twice as long as the rest, and is setose only on its outer margin. Nearer the base of the chitinous support are two fascicles, each composed of three long, simple setæ (*e*). These two sets of appendages, together with the setiferous bodies (*f*), may perhaps represent the maxillæ and maxillary palps. In some cases these organs are thrown forward, projecting in front of the mouth like a couple of horns. Considerably further behind and more removed from the median line is a pair of limbs (? maxillipeds), bearing two strong tooth-like processes (*g*) and five or six long setæ (*h*), while near the base of the appendage is an elevated circular disc bearing a crown of tentacular cirri (*i*). Still nearer the median line is a simple seta (*k*) elevated on a papilliform base, beneath which is a circular (? genital) aperture. Near the posterior extremity of the body are tufts of ciliated setæ (*l l*).

\* χώνη, a funnel.

† τρώγω, I gnaw.

My impression, on first examining this creature, was that it might perhaps be a naupliiform stage of some higher crustacean, but this view can scarcely, I think, be entertained, the general condition of the appendages being much more in accordance with the idea of retrogression arising from parasitic habits.

The views here expressed and the names applied to the various appendages must be taken as purely tentative and provisional. The animal is to a large extent anomalous, and some of the parts—as, for instance, those which I have called “maxillæ” and “tentacular cirri”—are so entirely unlike anything known to me in other Entomostraca, that their true nature and homologies must be left for future investigation.

What I mainly hope to achieve by bringing the subject before this Society is to point the way into a field of investigation which, I think, is likely to prove of the very highest interest.

I must, in conclusion, express my sincere thanks to Miss Barton for having allowed me to examine and describe her specimens.

---



SUMMARY OF CURRENT RESEARCHES  
RELATING TO  
ZOOLOGY AND BOTANY  
(PRINCIPALLY INVERTEBRATA AND CRYPTOGAMIA),  
MICROSCOPY, ETC.

*Including Original Communications from Fellows and Others.\**

---

ZOOLOGY.

**A. VERTEBRATA:—Embryology, Histology, and General.**

*a. Embryology.†*

**Experimental Embryology.‡**—Prof. O. Hertwig gives an elaborate account of his experiments and observations on Amphibian ova, made with the view of determining the rôle of the various segmentation cells in forming the organs of the embryo, and of deciding for or against Roux's mosaic theory of development.

By various compressions and modifications of the ovum's shape the course of segmentation, the direction and succession of the cleavage planes, and the size of the blastomeres are profoundly modified. The direction of the cleavage planes is always determined by the form and disposition of the cytoplasm. The position of the median plane of the embryo is *not* determined by the position of the first or second cleavage plane. In the various modifications of segmentation the nuclei, accompanied by portions of the yolk, are disposed in the most diverse fashion, "like a heap of balls thrown together." Qualitatively different portions of the segmentation nucleus are not separated in the segmentation; Weismann and Roux are wrong; in spite of the disordered distribution of the nuclear material normal embryos always arise. The ovum is certainly differentiated, e. g. into formative protoplasm and yolk, but it is "isotropic," i. e. it is not made up of predetermined organ-forming areas or specialized substances definitely arranged. Gravity has a directive influence in determining the distribution of material and the

\* The Society are not intended to be denoted by the editorial "we," and they do not hold themselves responsible for the views of the authors of the papers noted, nor for any claim to novelty or otherwise made by them. The object of this part of the Journal is to present a summary of the papers *as actually published*, and to describe and illustrate Instruments, Apparatus, &c., which are either new or have not been previously described in this country.

† This section includes not only papers relating to Embryology properly so called, but also those dealing with Evolution, Development and Reproduction, and allied subjects.

‡ Arch. f. Mikr. Anat., xlii. (1893) pp. 662-807 (6 pls.).

planes of cleavage, and its effects can be traced even in the form of the embryo.

If one of the first two blastomeres be completely destroyed, the surviving half forms a fairly normal embryo, with defects of slight importance; if the destruction be partial, division may still occur in the injured half, either in its own strength or with help from the uninjured half. But a destroyed half cannot be re-vitalized, nor does Roux's post-generation occur. The development in an uninjured half is quite normal. No semi-gastrula lateralis, nor hemi-embryo lateralis, nor the like is ever formed when one of the first two blastomeres is destroyed! The mosaic theory of development, the theory of organ-forming germinal areas, and the germ-plasm theory, are all contradicted by the facts.

The ovum is a specifically organized "Elementarorganismus," which develops epigenetically, i. e. with gradual differentiation according to the mutual relations of the embryonic cells, for a normal embryo may develop from one of the first four blastomeres; a disordered disposition of the nuclear materials has no effect; by artificial devices the medullary plate, &c., may be made to arise from cell material quite different from that which is used in normal development. These and many other facts and conclusions does Hertwig bring together in formidable antagonism to Roux's mosaic theory of development and Weismann's theory of the germ-plasm.

**Breeding in and in.\***—Dr. Ritzema Bos discusses the results of prolonged inter-breeding among nearly related animals. His experiments were made with the rat (*Mus decumanus*). From seven of one family and an unrelated male which died after two crossings, he continued breeding for six years without introducing fresh blood. There were about thirty generations. In 1887 the average number of a litter was  $7\frac{1}{2}$ , in 1891 it suddenly sank to  $4\frac{1}{2}$ , in 1892 to  $3\frac{1}{2}$ . The rate of mortality increased enormously after about twenty generations, and the number of infertile pairings likewise increased.

He concludes from his own and other experiments that continued breeding in and in lessens the reproductive capacity, may result in complete sterility, is associated with reduction of size, and perhaps causes greater predisposition to disease and malformations.

**Origin of Mammals.†**—Dr. W. Haacke returns to the subject of a speculative paper which he published in 1887 on the origin of Mammals. He then associated the rise of Mammals with the Permian glacial epoch, but he is not so precise now. Their origin illustrates "constitutional selection," he says, which seems to mean that in the process of natural elimination those forms with less suitable constitutions would be most likely to go to the wall. We should hardly have thought that a new phrase was necessary to express the idea.

He is pessimistic on the question of phylogeny. "We know nothing about the pedigree of Echinoderms, Crustaceans, Insects, Molluscs, and Annelids; we know absolutely nothing about the origin of Vertebrates, and are not in a position to say anything about the ancestors of Amphibians and Reptiles, Birds and Mammals." This is refreshingly

\* Biol. Centralbl., xiv. (1894) pp. 75-81.

† Op. cit., xiii. (1893) pp. 719-32.

cautious, but is the case really so bad? Haacke has no hope of our ever finding the parent stocks of the great types, his interest is in the possible physiological factors in the evolution.

"Constitutional selection" leads to increase of size, to differentiation. An ancestral blastula becomes invaginated and variously folded. Folding is the great process of differentiation, but he does not tell us why the folding occurs, except that it is due to "constitutional selection." The increased temperature of Mammals is referred to the increase of the lung surface by folding, which would have especially marked effects in a body so small as that of the early Mammals seems to have been. Hairs arise from the stimulus of the hot blood in the skin, and a case is cited where an unwonted difference of temperature between skin and outer world was associated with strong growth of hair. Perhaps the increased temperature of the blood was also associated with the origin of sebaceous glands, which probably arose in correlation with hairs.

It is startling to find it suggested that brood-pouch and mammary glands were more likely to have been acquired by the males than by the females. The early Mammals were possibly squirrel-like in their pose, and the males are supposed to have carried the eggs in their lap, as it were, till folds and a pouch naturally arose. By-and-by the males tired of this little way of theirs, but not before the presence of the eggs and young in the pouch had stimulated the integumentary glands into milk-giving. This acquisition has also been handed over to the females, though it is interesting to notice that the mammary glands of the male *Echidna* are exceedingly large. Moreover, Haacke does not exclude the possibility that when the Waitoteke of New Zealand is found it will be a male of the old-fashioned sort.

Dr. Haacke knows as well as any one else how bold some of his speculations are, and submits that they can do no harm as long as their purely speculative character is recognized. Though he solves no problems, his vigorous essay is stimulating, and it is refreshing to read such trustful Lamarckianism.

**Dentition of Mammals.\***—Prof. W. Leche adds to his recent important essay on the development of the dentition in Mammals an appendix dealing with *Myrmecobius fasciatus*, four types of Chiroptera, and *Phoca groenlandica*. In young forms of *Myrmecobius* he finds traces of a dentition acquired by lower Vertebrates, and preceding the first or milk-dentition of placental Mammals. As to the bats, he notes the peculiarity of *Desmodus rufus* in having the most anterior deciduous premolar laid down but not developed. Divergent as is the adult dentition of *Desmodus*, the milk-dentition agrees generally with that of the related *Stenoderma*. Important is the great independence of the enamel ridge, as seen in the very complete constriction off of the enamel germ, and in the occurrence of a swollen end of the ridge beside the premolars. In this, as also in *Phoca*, Leche finds evidence of a predisposition towards, or possibility of, a third set of teeth. After describing some stages in the dental development of *P. groenlandica*, the author discusses certain general questions.

\* Morphol. Jahrb., xx. (1893) pp. 113-42 (12 figs.).



In several Mammals the most anterior cheek-tooth is not replaced. Does it belong to the first or to the second dentition? In some cases it is preceded by a rudimentary milk-tooth, but in others, e. g. *P. groenlandica*, there is no distinct evidence of this. Yet from the nature of the tooth in question it seems to belong to the second set. But in other cases decision is difficult. It seems clear that each set or dentition should be regarded as a *generation* of teeth. The teeth which form the first set in higher Mammals form in more primitive types (in Marsupials, excepting Pm 3, and in Odontoceti) the only and the persistent set. Those of the first set retain ancestral characters which are lost in the second set. The rudiments of teeth belonging to the same set or generation differentiate contemporaneously, or almost contemporaneously, from the enamel ridge. This is the real criterion.

**Fertilization in the Mouse.\***—Dr. J. Sobotta has succeeded about a dozen times in observing the spermatozoon after it has penetrated into the ovum, and finds that the completion of the division which leads to the extrusion of the polar body does not take place until *after* the spermatozoon has entered.

**Development of Bladder and Urethra.†**—Dr. P. Reichel has studied this in embryos of the pig. The inner cloaca formed by the ventral folding of the tail end of the embryo is divided by two folds from the lateral-posterior wall (Rathke's folds) into a posterior narrow portion, the rectum, and an anterior wider portion which receives the Wolffian ducts and becomes the urinogenital sinus. The folds grow in and coalesce, the lower part of the cloaca is narrowed into the cloacal duct, the anterior main portion becomes the central part of the urethra and the bladder. Neither arise from the allantois, which opens into the upper part of the anterior bladder wall, in the pig by a canal which remains for a long time open, in man by a strand which has a narrower lumen and is soon closed—the urachus.

The cloaca is closed by the anal membrane, a residue of the primitive groove; this membrane grows into the cloacal septum, and the adjacent tissue grows into the genital tubercle. This is traversed from tip to base by the cloacal or urethral septum, which splits from behind forwards and forms the cloacal cleft or genital groove, thereby opening the cloaca. By fusion of the free, lip-like margins of the genital or urethral groove, the urethral canal is gradually formed. Clitoris and penis, clitoris-groove and the urethra of the penis are thoroughly homologous. But it is difficult to do more than indicate Reichel's general position, so complex are the structural relations of these urinogenital parts. It is evident, at least, from his and other researches that there is a departure from the old view which derived the bladder from an expansion of the stalk of the allantois.

**Development of the Hypophysis.‡**—Herr E. Gaupp has studied this in *Anguis fragilis* and *Lacerta agilis*, and finds that the hypophysis has a triple rudiment (*Anlage*). The epithelium of the oral cavity gives rise to a large roundish "median bud" and two elongated "lateral buds."

\* Anat. Anzeig., ix. pp. 220-3 (1 fig.).

† Verh. Phys. Med. Gesell. Würzburg, xxvii. (1893) pp. 147-89 (3 pls.).

‡ Arch. f. Mikr. Anat., xlii. (1893) pp. 569-80 (2 pls.).



The median bud undergoes modifications essentially similar to those which Mihalkowics has described for Mammals; the two lateral buds are temporarily united to the median bud, but acquire independent relations with the brain, and separate from the main mass of the hypophysis as two solid epithelial bodies.

**Origin of the Blood.\***—Prof. C. K. Hoffmann has studied this in the yolk-sac of Selachians (*Acanthias*), and corroborates his previous conclusion that the mesoblast has no share in forming the blood, but that blood and endothelium arise wholly and solely from the hypoblast. Some corpuscles appear to arise from the free nuclei of the yolk, which undergo fragmentation. But of greater importance is the remarkable process by which part of the hypoblast loses its epithelial character and is modified into the hæmenchyme tissue from which blood and endothelium develop. The author emphasizes the likeness of this tissue to adenoid or reticular connective tissue, and just suggests the physiological interest of the hypoblastic origin of the blood.

**Development of Head of *Gobius Capito*.†**—Mr. H. B. Pollard finds that, in this fish, the neural axis terminates at a point near the optic stalk, just as in the Salmon. An indentation and the arrangement of the cells at this point may be taken as indications of a neuropore. In later embryos there is evidence that the corpora striata belong to the upper part of the wall of the brain. The mouth and hypophysis arise as solid ingrowths of ectoderm, but there is nothing to show that the mouth was ever anything but a mouth. From a condensation of mesoderm round the ectodermic ingrowth of the mouth there arise the skeletal structures of both upper and lower jaws.

**Embryogeny of Selachii.‡**—Prof. P. Mitrophanow finds that the organs of the lateral line commence with a general thickening, along the sides of the head, of the epidermis; the median part is detached below the hyoid arch to form the auditory lamella; when this last is converted into the auditory pit, the parts of the hyoid and branchial arches become detached from the branchial thickening; this happens in order from before backwards. When the conversion of the auditory pit into the auditory vesicle is accomplished, there is a further detachment of epidermic thickenings. The anterior part which separates from the thickening of the hyoid arch divides into two epidermic rod-like structures which surround the eye; these, later on, form the supra- and infra-orbital mucous canals.

In connection with the general thickening of the hyoid arch a special thickening is formed which gives rise to the mandibular part of the lateral organs. Each branchial thickening undergoes a further dismemberment and six branchial organs are developed. Above each of these the part of the lateral organs is formed, and simultaneously with their development, there appear small suprbranchial nerve-branches. This lateral part gives rise to the lateral line of the trunk.

The author concludes that the lateral organ in the Selachians studied is primitively formed by the germs of the mucous canal:—(a) supra-

\* Verh. K. Akad. Wetenschap. Amsterdam, iii. 4 (1893) 26 pp., 3 pls.

† Quart. Journ. Micr. Sci., xxxv. (1894) pp. 335-52 (2 pls.).

‡ Arch. Zool. Expér. et Gén., i. (1893) pp. 161-220 (6 pls.).

orbital, (b) infra-orbital, (c) mandibular; by the portions above the suprabranchial branches, (d) of the ramus buccalis, (e) of the glosso-pharyngeal, (f and g) of the first and second branches of the vagus, and (h) by the germ of the lateral line strictly so called.

Derivation of the Pineal Eye.\*—Mr. W. A. Lacy has a preliminary notice on this interesting subject, of which the summary states that:—

(1) There are preserved on the cephalic plate of Elasmobranchs (*Squalus acanthias*) at least two pairs of accessory optic vesicles.

(2) These, taken with the primary optic vesicles, give to the embryo three pairs of rudimentary eyes.

(3) The anterior pair develop into the lateral eyes, and the first accessory pair form the walls of the thalamencephalon, and give rise to the principal outgrowth from it.

(4) The epiphysis, therefore, is double in origin, being formed from a united pair of accessory optic vesicles.

(5) Since the latter are homologous with the lateral eyes, their derivate—the epiphysis—is also homologous with the lateral eyes. But, as is pointed out, the differences in their structure need explanation.

(6) It is thought to be highly probable that the enlarged distal end of the epiphysis in *Squalus* is homologous with the pineal eye in those forms in which the eye is differentiated.

Development of the Vertebral Column.†—Dr. C. Hasse publishes a sixth communication on this subject. This is concerned with the vertebral column of the Cyclostoma and of *Petromyzon fluviatilis* in particular. There is no intercuticular layer and no *cuticula sceleti* (*Elastica externa* aut.), but besides the *cuticula chordæ* (*Elastica interna* aut.), there is a fibrous sheath formed from the cells of the chorda-epithelium. The Cyclostoma are thus essentially different, as regards vertebral column, from Elasmobranchii and Urodela; the development represents a distinct type, which the Ganoids and perhaps also the Dipnoi have followed.

Concerning the Gonotome.‡—Prof. C. S. Minot maintains that there is no such thing. The word and the idea are due to van Wijhe, who credited Rückert with discovering that the gonads of *Pristiurus* were segmented. But Rückert made no such discovery. Minot also points out that the “primitive ova” have a very wide distribution, e. g. in the mesothelium of the mesentery in young *Acanthias* embryos, in the nephrotome, in the splanchnopleure of bird-embryos. In fact, under the title “primitive ova” are included cells which cannot form part of the future gonads. It is suggested that the characteristic features may be due to an increase of cell-sap associated with mitosis.

Inheritance of Acquired Characters.§—Dr. L. Reh points out, as has been pointed out before, that experiments as to the transmissibility of mutilations are not of great importance in regard to the problem of the inheritance of acquired characters. As far as we understand him, however, he does not adequately realize that the transmission of certain

\* Anat. Anzeig., ix. (1893) pp. 169–80 (5 figs.).

† Zeitschr. f. wiss. Zool., lvii. (1893) pp. 290–305 (1 pl.).

‡ Anat. Anzeig., ix. (1894) pp. 210–3 (1 fig.).

§ Biol. Centralbl., xiv. (1894) pp. 71–5.

results of mutilations would prove that the germ-cells could be specifically affected by the body. According to Reh, whose paper has a pleasant cirenic tone, acquired characters are certainly transmitted, but they presuppose a definite rudiment, *Anlage*, or predisposition. It is evident that, if there were not the possibility of their arising, they would not arise! A somatogenic adaptation, he says, is not a completely new acquisition, it is only the outcrop of latent qualities; latent, not in Weismann's sense, but in a purely physico-chemical manner, as there is in water the latent quality of becoming steam at 100° C. The whole question seems to him so simple that he wonders there has been so much argument over it.

### β. Histology.

Spermatogenesis in *Salamandra maculosa*.\* — Dr. O. vom Rath devotes the first half of his paper to the "Reduktionsfrage." As a preliminary he points out that, to avoid error, he will make use of Hertwig's terminology. That is to say, the *primordial genital cells* give rise by mitosis to *indifferent germ-cells*, from which, on sexual differentiation, *primitive sperm-* and *primitive egg-cells* arise. This is the first period. In the second there are periods of growth and rest, and the sexual cells become *sperm-mother-cells* or *egg-mother-cells*. In the third period, or that of maturation, the mother-cells divide and give rise to daughter- and granddaughter-cells. The sperm-granddaughter-cells (spermatids or unripe sperm-cells) undergo a more or less complicated metamorphosis and form spermatozoa (spermatosomes or ripe sperm-cells); the fourth period, which obtains only in spermatogenesis, is the period of conversion. By "Reduktionstheiling" the author means, with Weismann, every division of the nucleus in which the number of ids present in the resting nucleus is reduced to a half for the daughter-nuclei.

The author finds that in all cases of spermatogenesis or oogenesis investigated by him the quadripartite groups arise before the maturation period in the same way; in the coil-stage two adjoining segments remain connected with one another, and are in connection with the two similarly connected sister-segments, which have been formed by longitudinal cleavage of the chromatin-filament; this connection may be more or less intimate. From each of these four segments there then arise, by contraction, four rod-like or spherical chromosomes. Dr. vom Rath thinks, therefore, that it is most natural to regard each quadripartite group as consisting of four separate chromosomes.

Dr. O. vom Rath discusses in a second paper † the significance of amitosis in sexual cells, and its appearance in the genital apparatus of *Salamandra maculosa*. He comes to the conclusion that the amitotic phenomena observed in sexual cells support the empirical and theoretical results which he has established by observations on amitosis in somatic cells. When amitosis occurs in the testis, ovary, or as yet undifferentiated rudiment of a gonad, it occurs either in temporary investing cells or in sexual cells which develop no further and degenerate. The statements of those who suppose that amitotic phenomena must always

\* Zeitschr. f. wiss. Zool., lvii. (1893) pp. 97-40 (1 pl.).

† Tom. cit., pp. 141-85 (2 pls.).



enter into the division-cycle of ovarian or seminal cells must be received with the greatest caution; all such statements should be re-investigated, and it is probable that in all cases they will be found to be without foundation. The view of some authors that there is no important distinction between amitosis and mitosis is, in the present state of our knowledge of the processes of nuclear division, seen to be erroneous.

**Import of the Chief Nucleolus.\***—Dr. V. Häcker distinguishes the numerous accessory nucleoli from the single large chief nucleolus. The former, as seen in the germinal vesicles of many Vertebrates, are said to contain the products of metabolism in the chromatin; the latter, as seen in Echinoderm ova for instance, is a more differentiated “organulum”—a “rhythmically pulsating organ of excretory and probably also of secretory (or secretion-storing) importance.” Häcker’s observations, of which a full account is promised, relate chiefly to the nuclei of *Cyclops*, *Cryptochilum*, *Canthocamptus*, and the like.

**Changes induced by Urari in the Wandering Cells of the Frog.†**—Mr. W. B. Hardy and Dr. Lim Boon Keng find that the introduction of urari leads to an increase in the number and in the size of the cells in the lymph, followed by a decrease which is greater than the increase. This increase is due both to immigration and to proliferation. The destruction of cells is, at first, of the nature of a passive death and dissolution of the cells in the plasma; later on, cells with apparently normal granulation and nuclei are bodily ingested by enlarged hyaline cells. These latter manifest phagocytosis at an early period, and during the resolution of the disease they mainly destroy the eosinophile cells.

#### γ. General.

**Influence of Low Temperature.‡**—M. R. Pictet has made since 1869 numerous experiments on the influence of extreme cold on organisms. Selecting forms whose normal life is well known he plunges them into vessels containing dry air at temperatures varying from +10 to -200° C. and observes the effect on the various functions. In a dog thus subjected to -92° the breathing becomes more rapid, the heart-beats become more frequent, and for some minutes the temperature actually rises about half a degree. The animal becomes agitated, and though lately fed it eats hungrily. After forty minutes, the temperature is still about 37°, but within the next half-hour a sudden lowering sets in, and resuscitation is impossible.

Freshwater fishes were slowly frozen at from -8° to -15°, but all survived; but a temperature below -20° was fatal. Frogs survived -28°, but most were killed by -30° to -35°. A snake survived -25°, but died at -35°. Centipedes resisted -50°, but succumbed at -90°. A snail escaped death at -110° to -120°, but two others died at the same temperature. Below -1° the eggs of birds died, frog ova survived slow cooling to -60°, ant-eggs were all killed between zero and -5°. The eggs of silk-moths survived -40°, and this temperature seemed to free them from microbes. Rotifers and Infusorians

\* Ber. Nat. Ges. Freiburg, vii. (1893) pp. 113-6.

† Journal of Physiology, xv. (1893) pp. 361-74 (1 pl.).

‡ Arch. Sci. Phys. Nat., xxx. (1893) pp. 293-314.



survived  $-60^{\circ}$ , were mostly killed at  $-80^{\circ}$  to  $-90^{\circ}$ , and were wholly destroyed at  $-150^{\circ}$  to  $-160^{\circ}$ .

Bacteria, spores, diatoms, seeds and the like seem to defy the lowest temperatures. Even exposure to about  $-200^{\circ}$  in liquefied air did not kill either germs or seeds. Vaccine fluid, however, was rendered innocuous.

The simpler the organism is, the greater its power of resistance. Each grade of structure has its limit of temperature, rising as we ascend the series. Thus mammals and flowering plants are relatively very sensitive. Sudden cooling of the higher animals is followed by an energetic reaction which may be found to have therapeutic importance.

At  $-100^{\circ}$  chemical processes cease; much more so in seeds, germs, and spores subjected to  $-200^{\circ}$ . Yet these seeds, germs, and spores revive! Life is a phenomenon analogous to gravitation: it does not die as long as the structure in which it manifests itself is intact; it is one of the constant forces of nature.

**Phenomena of Convergence.\***—Dr. F. Werner describes convergence as the independent occurrence of similar organs, colourings, markings, movements, protective and aggressive adaptations, and the like, in types which are phylogenetically distinct, but which agree in having similar functions, habits, surroundings, &c. In short, the term convergence is applied to cases where similar adaptations occur in unrelated forms; or convergence is, in Prof. Ray Lankester's terminology, a case of "homoplasy," but not of "homogeny."

But the distinction, easy enough in theory, is not quite so easy in practice. Thus, there are three snakes, *Coluber oxycephalus*, *C. frenatus*, and *C. prasinus*, sometimes united under the title *Gonyosoma*, and closely alike in adaptation to arboreal life. Do they illustrate the *divergence* from one ancestral *Gonyosoma* type, or the *convergence* of three distinct species of *Coluber*? In regard to forms of relatively close affinity, the question is difficult; in regard to kangaroo and jerboa it is easy.

Werner goes on to discuss (1) "horns," from those of a beetle to those of a rhinoceros; (2) the extension of the skin to form webs, parachutes, and the like; (3) the adaptations to arboreal life seen among snakes; (4) adaptations to aquatic life; (5) the characters of burrowing animals, e.g. reduction of appendages, tail, and eyes, obliteration of the distinction between upper and under surface, and increase of the rostral region; and scores of other examples of convergence.

## Mollusca.

### γ. Gastropoda.

**Doridiidæ.†**—Dr. R. Bergh states the characteristics of this group as follows. The body is covered by two separate shields. The anterior shield, hardly separable in front from the small head, has slightly projecting lateral margins, and the hind margin may overlap the posterior shield. The posterior shield has its hinder part prolonged laterally in two flat wing-like processes. The strongly developed foot is continued laterally into two large pleuropodia, curved upwards to cover the sides of the body and part of the back. The shell is sometimes of considerable

\* Biol. Centralbl., xiii. (1893) pp. 471-6, 571-6.

† MT. Zool. Stat. Neapel, xi. (1893) pp. 107-35.

size, covers the hermaphrodite organ, part of the liver, &c., consists of a small spire, and a wide coil, and is either quite cuticular or partially calcified. The pharyngeal bulb is of immense size, prismatic in form, exceedingly muscular, and without mandibles or tongue. The penis has a superficial lateral groove, and the large prostate is bilobed or simple. The Doridiidæ are predacious, darkly but strongly coloured, restricted to warm and tropical seas, and include two genera—*Doridium* and *Navarchus*. Six species of *Doridium* (four new) and two species of *Navarchus* (one new) are described.

**The Genus Gastropteron.\***—Prof. R. Bergh publishes a systematic study of the genus *Gastropteron*, the only type of the family Gastropteriidæ, which occupies a somewhat terminal position among the aspidoccephalous Steganobranchii (Tectibranchs).

As to the characteristics of the genus: the anterior body is covered by a cephalic disc or shield, whose posterior end projects freely, is very mobile, and is evidently a tactile organ; the enormously developed pleuropodia are at once distinctive; the posterior body is short and sack-like, and quite free from the hind part of the foot or tail; along the anterior half of the right margin there is a small mantle flap which covers the gill and the openings beside it; in the typical species the flap is continued backwards as a mobile flagellum; the internal shell is extremely thin, its large terminal portion covers a great part of the posterior viscera, its small posterior end is nautiloid with two coils, more or less calcified; the pharyngeal bulb is divided into two parts; the radula has but a few rows of teeth, the stomach is without armature, the glans penis has no groove; the prostate is very long and cylindrical.

Two species are described, *G. Meckeli* Blainv. from the Mediterranean, and *G. pacificum* sp. n. from the Pacific.

**Morphology of Sacoglossa.†**—Dr. H. von Ihering, after describing more or less in detail various forms, points out that the ordinary doctrine that, in hermaphrodite animals, the sperm and ova mature at different times is absolutely false. With regard to the affinities of the group the Æolidiidæ are not at all close to it, for they differ in important points of the structure of digestive and genital organs, while the dorsal papillæ contain branches of a tubular gland. The closest affinity appears to be to the Doridiidæ.

The author does not seem to be at all satisfied with recent speculations as to the origin of the Mollusca, and declares, apparently in all seriousness, that no explanation remains for him save the supposition that the Vermes were derived from the Mollusca.

**Excretory and Reproductive Apparatus of Elysia.‡**—Prof. P. Pelseneer finds that the most striking character in the renal organ of *Elysia*, and one that is unique among Molluscs, is the multiplicity of the reno-pericardiac ducts, of which there are, at least, ten. These ducts are short, and have a high ciliated epithelium. The author believes that the most anterior or ventral of the pericardiac orifices is the

\* Zool. Jahrb. (Abth. Anat. Ontog.) vii. (1893) pp. 281–308 (2 pls.).

† Nova Acta Acad. Leop. Car. Nat. Cur., lviii. (1893) pp. 363–435 (2 pls.) Also separately, Halle, 1892.

‡ Zool. Anzeig., xvi. (1893) pp. 458–60.

homologue of the single orifice of other Molluscs; the other ducts appear to be secondary or cenogenetic, and are probably due to the many points of contact between the pericardium and the kidney. As the kidney of *Elysia* is a single unpaired nephridium and not derived from the fusion of several nephridia, as is probably the case in flat Worms, this multiplicity of ducts is no support to the view that the Mollusca are allied to the Platyhelminthes.

The gonad is much broken up and scattered in the posterior part of the body; it is made up of globular acini which are entirely hermaphroditic; at the same time, the hermaphroditism is protandric. Of the three genital ducts the most ventral is the spermoviduct, the median is the duct of the so-called prostate, and the most dorsal is the duct of the tubular gland, which extends through the whole of the body. The true genital duct divides into two branches, of which the left is oviducal, and has on its course a uterine enlargement; the uterus receives the duct of the large copulatory pouch, a second branch from which opens into the oviduct; the right branch is connected with the penis. In addition to the orifices of these two ducts there is a third which is connected by a fine duct with the uterus, and has a vaginal function. It is remarkable that this third orifice and its canal are developed later than the two other genital openings; *Limapontia* exhibits a similar bifurcation of the female ducts.

**Nervous System of *Nerita* and *Navicella*.**\*—From a study of the nervous system of these Molluscs, and a comparison thereof with that of *Turbo*, M. L. Boutan is led to conclude that there are no orthoneurous Aspidobranchs, and that the division into chiasmoneurous and orthoneurous Aspidobranchs is based on an incomplete study of the nervous system. In *Nerita* we find the same ganglion as in other Aspidobranchs, and the homology between the different parts of the nervous system is complete. The cerebral ganglia are connected with one another by a commissure which passes below the digestive tube, and is independent of the stomatogastric ganglia. The pedal ganglia have the form of a ganglionic chain, but only supply the foot proper. The two first ganglia of the visceral centre innervate the mantle and the muscles of the shell; they are connected with the rest of the visceral system by two crossing commissures, which form a figure of 8 before passing to the ganglia situated above the digestive tract. The fifth ganglion of the visceral or asymmetrical centre is represented, in its usual position, by a ganglion which sends out branches to the anterior part of the digestive tube.

The special character of the nervous system of *Nerita* is due to the special importance of the pallial nerves, and to the fact that one enters into close relations with the left gill. This pallio-branchial nerve is prolonged into the respiratory organ, which is therefore innervated by the first asymmetrical ganglion of the right side by means of the crossed branch of the commissures, and also by the left ganglion by means of the pallio-branchial. It would appear that the gill which is primitively innervated by the right ganglion has a tendency to be innervated exclusively by the left, for the branch from the right side is very delicate, and seems to be undergoing atrophy.

\* Arch. Zool. Expér., i. (1893) pp. 221-66 (2 pls.).



The study of the pallial nerves shows that the epipodium is innervated only by the nerves which arise from the two first ganglia of the asymmetrical centre, and that all the other pallial nerves which are distributed in the median lobe of the mantle also have their origin in the two first ganglia of the asymmetrical centre.

**Shell Cavity of Philinidæ.\***—Prof. P. Pelseneer finds that the shell cavity of *Philine*, or the cavity formed by the mantle which covers the shell, is not, as is generally supposed, completely closed; it communicates with the exterior by a canal, the wall of which is formed by a ciliated epithelium of some height. The allied *Doridium* presents much the same arrangement.

The presence of this canal in two Gastropods with a shell cavity said to be closed raises the question if Mollusca with an internal shell have not also an external orifice to the shell cavity. In a *Sepia*, and in a *Pleurobranchus*, no canal could be seen. The author suggests that various Mollusca with an internal shell have retained a communication with the exterior, so that the pressure in the cavity may be the same as that outside, whatever changes in depth the animal may undergo.

**Kidney of Snail.†**—M. P. Girod finds in the urinary bladder of *Helix pomatia* a special alkaline gland, the function of which is to transform, by secretion, into urate of soda the uric acid excreted by the kidney. It will be interesting to see if this is true of other Mollusca in the excretory cells of which uric deposits have been found.

**New Polycerad.‡**—Dr. R. Bergh describes from the Adriatic a new Dorid which he calls *Greilada* (*G. elegans* sp. n.); it stands very near to *Polycera*, but is distinguished by the absolute want of dorsal appendages. The mandibles are connected with one another by a cuticular intermediate piece. In the radula and many parts of the male apparatus it is almost exactly like *Polycera*.

**Growth Changes of Radula in Land Mollusca.§**—Dr. V. Sterki finds great variations in the number and shape of the teeth on the radula at different stages of life; it is not yet certain whether new teeth are added and changes go on after maturity or not; in some cases the forms of teeth in the embryo are quite different from those of post-embryonic life. As the new formation and transformation of teeth is, as a rule, not exactly symmetrical on the two sides of a radula, the formula of one side is often only approximately true. The increase of width of the whole is effected exclusively by the addition of new longitudinal rows. The new formation of the radula as a whole is more rapid than is generally supposed.

**Mollusca of Water Mains of Paris.||**—M. Locard finds that at least forty-four species of Mollusca dwell in the water mains of Paris, and four of them are regarded as new. The apparently strange fact of the absence of *Unio* and *Anodon* is explained by the absence of fish, to which the larvæ of these common freshwater forms are in the habit of attaching

\* Comptes Rendus, cxvii. (1893) pp. 810 and 11.

† Op. cit., cxviii. (1894) pp. 294-6.

‡ Arch. f. Naturg., lx. (1894) pp. 1-6 (1 pl.).

§ Proc. Acad. Nat. Sci. Philad., 1893, pp. 388-400 (2 pls.).

|| Rev. Scient., 1893. See Amer. Natural, xxvii. (1893) p. 1094.



themselves. The main-dwellers are reduced in size, and less strongly coloured, in consequence of the want of light; a steady rapid current has caused a lengthening of the shell, and the shells themselves are polished, brilliant, and uniform.

**Check-List of Slugs.\***—Prof. T. D. A. Cockerell has prepared a check-list of the slugs, to which Mr. W. E. Collings has added an appendix and notes. Six hundred and twenty-eight species are enumerated. The difficulty of a worker who knows only British forms is that they are, for the most part, very distinct from one another, whereas in Southern Europe and elsewhere there are many forms closely allied to the British.

### Molluscoida.

#### a. Tunicata.

**Eyes and Subneural Gland of Salpa.†**—We gave such a full notice of Mr. M. M. Metcalf's preliminary paper,‡ that we must content ourselves with calling attention to the publication of the paper in full. In three appendices he brings the work up to date by critical references to recently published memoirs.

**Salpæ of Berlin Museum.§**—Dr. C. Apstein has made a revision of the collection of Salpæ at Berlin, and finds that there are twelve species and two varieties, represented by 849 specimens. *Salpa bicaudata* Q. and G. is found to be equal to *S. scutigera confœderata* form *bicaudata*. *S. quadrata* Herdm. = the solitary form of the same. *S. democratica mucronata* var. *flagellifera* Traust. = *S. flagellifera* Traust. *S. aspera* Cham. = *S. runcinata fusiformis* var. *echinata* (Herdm.); and *S. antarctica* Meyen = *S. africana maxima* prol. sol. This last species has been taken in the Pacific.

**Tunicata collected by Dr. Sander.||**—Herren M. Traustedt and W. Weltner found three new species among the six Ascidiacea collected by Dr. Sander during the voyage of the German war-ship 'Prinz Adalbert'; these are *Cynthia Sanderi* (Nagasaki and Yokohama), *Styela longitubis* (Yokohama), and *Phallusia princeps* (Cape Town). Five Thaliacea were collected. The compound forms have not been worked out.

#### β. Bryozoa.

**Contributions to our Knowledge of Polyzoa.¶**—Dr. H. Prouho continues his investigation of marine Polyzoa. He begins with a few notes on terminology. The term *Bryozoite* may be conveniently applied to any member of the colony, either to the single oozoite or to any one of the numerous blastozoites. He will continue to use the terms zoecium, cystid, and polypide, though he regards the Bryozoite as an indivisible unity; the zoecium or cystid is the protective external skeleton, the

\* London, 8vo, 1893, 58 pp. Reprint from *Conchologist*, ii, pp. 168-76 and 185-232.

† Baltimore, 1894, 4to, 65 pp., 11 pls. Reprinted from part 4 of W. K. Brook's *Memoir on the Genus Salpa*. ‡ This Journal, 1892, pp. 466 and 7.

§ *Arch. f. Naturg.*, lx. (1894) pp. 41-54 (1 pl.).

|| *Tom. cit.*, pp. 10-14 (1 pl.).

¶ *Arch. Zool. Expér.*, x. (1892) pp. 557-656 (8 pls.).

polypide includes the digestive, nervous, and muscular organs. But the dual or polypo-cystid interpretation of the individual Bryozoite is rejected.

Taking *Flustrella hispida* as a type of *Gymnolæma*, the author discusses the relations of the adult tissues to those of the larva. The walls of the oozite consist of a cellular layer ("endocyst" of some), which secretes the chitinous ectocyst, and this layer arises directly from the larval ectoderm. Below it is a delicate parietal cellular layer, reflected around the invagination destined to form the orifice, and continued down the gut to the funiculus. This is wholly derived from the larval mesoderm, and it gives rise to the muscles and gonads. It is simplest to call it the mesodermic tissue. As the endoderm of the larva disappears by histolysis, ectoderm and mesoderm form the whole of the adult, the former giving origin to the external sheath, the epithelium lining the gut, and the nervous system, the latter producing all the other structures.

Prouho proceeds to describe *Pherusa tubulosa*, *Alcyonidium variegatum* sp. n., *A. albidum*, *A. duplex* sp. n., *Membranipora pilosa*, *Hypophorella expansa*. Important as his descriptions are, we shall restrict ourselves to summarizing what he has to say in regard to the development of the larva (of the *Cyphonautes* type), as observed in *Membranipora pilosa*, *Alcyonidium albidum*, and *Hypophorella expansa*.

There is, however, an important discussion of the "intertentacular organ," the result of which must be noted. "The intertentacular organ of *Gymnolæma* is a genital duct existing only in the sexual Bryozoites, never exhibiting the structure of a nephridium, but having the same position as the orifice of the metanephridium in *Phylactolæma*, and serving, secondarily, for the evacuation of the débris of the degenerated polypides."

The ovum, which is detached from the ovary into the general cavity of the body, is irregular in form, and exhibits sluggish amœboid movements. Before fertilization and oviposition the ovum shows a very delicate vitelline membrane. Shortly after the egg is laid this membrane is separated off, and two polar bodies are extruded. In the three species above-named there is self-fertilization. Segmentation is equal and regular to the stage of sixteen blastomeres. Thereafter the primitive radial symmetry is changed for a bilateral arrangement. At the 32-cell stage four granular cells are invaginated or surrounded by the others, and form the beginning of the endoderm, but the gastrula is a sterogastrula without archenteric cavity. The region of the blastopore is soon closed. Soon thereafter two mesodermic cells appear, but their precise origin was not discovered. Then follows a series of modifications which lead to the stage with an oral invagination and an excentric endodermic mass. The larval gut consists of an endodermic mesenteron, a proctodæum, and the oral invagination or stomodæum. Prouho ventures the generalization that all ectoproctous Bryozoa with a free development have a larva of the *Cyphonautes* type. He compares this with the bivalved larva of *Flustrella hispida*, with the larva of *Pedicularina*, and, incidentally, with a *Pilidium*.

In a final chapter the author discusses some more general questions.

(1) It is characteristic of Bryozoa that the ectoderm retains the power

of forming a fresh endoderm or intestinal epithelium. Perhaps the suppression of the primary endoderm is one of the results of a simplification of ontogeny induced by perfected viviparity. In this connection, the five known types of development in Bryozoa are contrasted in a table. (2) The author holds strongly to the opinion that the Ectoprocta and the Endoprocta should be kept in one class. (3) The dual or polypo-cystid theory must be entirely abandoned. (4) He agrees with Ostroumoff and Harmer that the degeneration of the polypide may be related to the absence of an excretory system. (5) In the loss of the calyx in Ectoprocta there is not, however, any real analogue of the formation of "brown bodies," i. e. of the moulting of the polypide, which occurs in Ectoprocta. (6) The absence of an excretory organ may explain the degeneration of the gut in the *Cyphonautes* larva at the time of metamorphosis, while in the larva of *Pedicellina*, which has an excretory apparatus, the gut is handed on to the adult.

Prof. E. Ehlers\* reviews Prouho's investigations. He discusses, in particular, the openings to the exterior, showing at a glance in a diagram, what cannot be briefly stated in words, the relative positions of mouth, anus, ganglion, excretory aperture (in *Pedicellina*), nephridial aperture (in *Phylactolæma*), intertentacular organ (in *Membranipora* and *Alcyonidium*), and genital openings (in *Pedicellina* and *Hypophorella*). He briefly indicates how his conclusions bear upon the relationships of the different types.

New and Rare Irish Polyzoa.†—Mr. J. E. Duerden finds that the west coast of Ireland is proving very rich in the rare species of Polyzoa; very little attention has as yet been given to them, and it is expected that full investigation will prove of great interest in relation to geographical distribution. The present paper only deals with *Retepora*, *Crisia*, the *Triticellidæ*, and *Barentsia*. *R. couchi* is for the first time recorded from Ireland, and the five colonies found are of a larger size than any yet reported from England. All the ten British species of *Crisia* enumerated by Mr. Harmer in his recent revision have been found in Ireland. The abundance of *Triticella* enables the author to add a generic character—the presence of a continuous horny crust from which the peduncles arise; the south-west of Ireland appears to be the home of the *Triticellidæ*.

## Arthropoda.

### a. Insecta.

Antennary Sensory Organs of Insects.‡—Mr. C. M. Child has a preliminary notice of his investigations on a sensory organ found at the base of the antennæ of various Insects. He is inclined to think that the organ has not an olfactory but an auditory function; the nerve-endings lie in such a way that every movement of the distal part of the antennæ act as a stimulus.

\* Nachricht. Univ. Göttingen (1893) pp. 483-90 (sheet disarranged in printing).

† Proc. R. Irish Acad., iii. (1893) pp. 121-36 (1 pl.).

‡ Zool. Anzeig., xvii. (1894) pp. 35-8.



**Pigmentation in scales of Lepidoptera and Coleoptera.\***—Dr. F. Urech gives a detailed discussion of this subject, to which he has previously made numerous contributions.† In these he gave evidence in support of the conclusions that the simplest pigments are greenish-yellow to yellow, and that, with increasing molecular weight in the pigments, orange, red, violet, blue, and green may successively arise, and that sometimes there is in the ontogenetic succession of colour a recapitulation of the phylogenetic progress. Another important general conclusion, to which Urech has contributed, is this,—that the pigments of the scales in Lepidoptera belong to the uric acid group and to related groups, including the “nuclear-bases” (xanthin, hypoxanthin, adenin, guanin), which are so-called because they are the spontaneous decomposition-products of nuclein along with albumen and phosphoric acid. Individually, these nuclein-bases are colourless, but their mutual actions produce green and violet and otherwise coloured by-products. Perhaps the nuclein-bases arise from leucocytes which part with their pigment to epithelial cells.

After explaining his chemical and physical methods, Dr. Urech gives a summary of his results as to the behaviour of the pigments in relation to various reagents. These results are stated in over two dozen pages of tables. The most general result is that from white to yellow, and onwards through red and brown, the pigments are less and less soluble in water, until solution in water becomes impossible, as is the case with blackish pigments which are usually soluble only in nitric acid.

**Androconia of Lepidoptera.‡**—Mr. M. B. Thomas discusses the so-called scent-scales or hairs of male Lepidoptera. He finds them to be the outlet of certain glands in the tissue of the wing beneath the androconia-bearing surfaces. When the surface of the wing is covered with a large number of papillæ, from the end of which the scent-scales project, the latter are quite small, and there is but one to each papilla; this gives the scale the appearance of a small rod placed in a flask. The material elaborated by the glands and distributed on the surface of the wing by the androconia gives to many Lepidoptera their characteristic odour.

**Development of Compound Eye of Vanessa.§**—Mr. H. Jobansen denies that the first step in the formation of the eye is, as Patten states for *Vespa*, an invagination. The cells of the epidermis unite to form ommatidia soon after the eyes of the larva are detached from the epidermis. Of the numerous leucocytes which owe their origin to the dissolution of the organs of the larva, thirteen take part in forming an ommatidium; the cells which carry Claparède's “nuclei of Semper” may, the author suggests, be called Semper's cells. There appears to be sufficient evidence that the faceted eye of tracheate Arthropods should be considered as, phylogenetically, an assemblage of simple eyes. The

\* Zeitschr. f. wiss. Zool., lvii. (1893) pp. 306-84.

† Zool. Anzeig., xv. (1892) pp. 284-90, 293-306.

‡ Amer. Natural., xxvii. (1893) pp. 1018-21 (1 pl.).

§ Congrès Internat. de Zoologie, ii., part 2 (1893) pp. 124-6.



formation of crystalline cones is not an external excretion, as Claparède thought, but an internal excretion; within each of Semper's cells there appears a small mass of substance of the crystalline conc. The rhabdom is not an excretion of the cells of the retina, but a modification of the protoplasm of these cells. The facets of the cornea are not formed by a layer of cells different from those which form the crystalline cones. The leucocytes convey the pigment of the eyes of the larva to the epidermic cells which become converted into ommatidia, and they transform the pigment of the eyes of the larva into the pigment of the eyes of the imago.

The optic ganglion of the latter is derived from that of the former; the only new formation is the layer of nerve-bundles.

**Spermatogenesis of Bombyx Mori.\***—Mr. K. Toyama Nogakushi was struck with the varieties of cellular elements which are to be found in the testes of a larva after the fourth moult. Near the blind end of each testicular follicle there is a large cell, around which small cells are arranged concentrically. If the early history of this cell be traced it will be found that it is not a germ-cell, as Verson states, but corresponds rather to the supporting cells of the testes of Vertebrate, or the rachis of the *Ascaris* egg-string. Though not constantly present in the gonads of Lepidoptera this cell is not rare.

As the more developed sperm elements always lie near the vas deferens, while the younger elements lie near the blind end of the follicle, it is possible to distinguish the formative, the growing, the ripening zones, and the zone of metamorphosis. Brief notes are given on each of these, and a more detailed and illustrated account is promised.

**Life-history of Bombycine Moths.†**—Prof. A. S. Packard, in view of the philosophical importance of the study of caterpillars, recommends that:—

(1) The larvæ should be treated as though they were adult, independent animals, and their specific and generic as well as family characters should be worked out.

(2) The origin of mimetic and protective characters should be traced, and the time of larval life when they are assumed ascertained.

(3) This will involve the history of the development of the more specialized setæ, spines, tubercles, spots and other markings.

(4) Facts should be obtained regarding the ontogeny of American species and genera; as these, when added to what is known of the life-histories of Bombyces from other continents, may lead to at least a partial comprehension of the phylogeny of the higher Lepidoptera.

The author proceeds to give notes on the early stages of *Dryopteris rosea*, the larva of *Lacosoma chiridota*, and of that of *Perophora melshheimerii*; as to this last he notes the adaptational characters, among which we may note its wonderful power of shortening its body and thus dilating it so as to enable it to retain its hold in its case and prevent its being drawn out by birds, as well as its stout jaws which enable it to

\* Zool. Anzeig., xvii. (1894) pp. 20-4.

† Annals New York Acad. Sci., viii. (1893) pp. 41-92.

bite firmly, and its unusually fierce and courageous disposition, which has undoubtedly been developed as the result of successfully withstanding the attacks of birds. The life-history is given of *Orgyia antiqua*, and there are notes on the early stages of *O. leucostigma*, and on the transformations of *O. cana*. There are notes on a number of other species.

**Colours of Lepidopterous Larvæ.\***—Prof. E. B. Poulton supplies the experimental proof that the colours of certain Lepidopterous larvæ are largely due to modified plant pigments derived from food. To do this he selected a species (*Tryphæna pronuba*) the larva of which normally eats green leaves, and fed it from the egg with parts of the plant from which all colouring-matter is absent. The fact that brown pigments may be due to modified plant-pigments is a discovery, but it is not to be supposed that in many cases the brown colour is not proper to the larvæ.

Although Prof. Poulton's experiments were successful in establishing the conclusion they were intended to test, they point, as he shows, rather to the beginning of an investigation than to its end. It is now known that certain larval colours are dependent on the existence of modified plant-pigments, and this naturally leads to an inquiry into the nature and causes of the processes by which chlorophyll and etiolin are, in the animal body, converted into a comparatively stable brown or green substance, which is far removed from its original position in the digestive tract, and situated so as to form an important element in the effective colouring of the individual.

**Sexes of Larvæ of *Smerinthus populi*.†**—Prof. E. B. Poulton has made an investigation on the sexes of larvæ emerging from the successively laid eggs of *Smerinthus populi*. He was struck with the comparative rarity of death from internal causes, and is strongly impressed with the overwhelming importance of the struggle with highly organized enemies in determining the vast amount of destruction which occurs in the natural state. The period of development within the egg appears to be extremely uniform. The total number of eggs laid by one female were 193, from which 68 female and 59 male pupæ were obtained. The results afford no support to the opinion that the sex of Insects can be determined by external conditions during larval life; it may, however, be admitted that the larger female larvæ require more food, chiefly to prepare for the amount of material to be stored up in the ova. It would not, therefore, be surprising if, with a minimum of food, the female larvæ were starved before the males, but the consequent emergence of a number of males would in no way support the view that a scanty diet "determines" this sex. Prof. Poulton suggests that some writers on this subject have mistaken favouring for determining conditions.

**Reproductive Organs of *Noctua pronuba*.‡**—Dr. A. B. Griffiths gives a short account, which is purely descriptive, of the reproductive organs of this moth; it would appear that this is the first account of the organs of generation in the genus *Noctua* [sic].

\* Proc. Roy. Soc. Lond., liv. (1894) pp. 417-30 (2 pls.). See this Journal, 1893, p. 734.

† Trans. Entomol. Soc. London, 1893, pp. 451-6.

‡ Proc. Roy. Soc. Edinb., xx. (1893) pp. 94-102 (1 pl.).

**Indian Moths.\***—In our April part last year we noticed Mr. G. F. Hampson's first volume on Moths in the Fauna of India series, and now the second has just appeared; it consists of 610 pages, as against 530 in vol. i., though almost the same number of genera are dealt with—325 against 333—as is shown by the process-block illustrations, of which there is one to each genus.

The scheme of classification sketched out in vol. i. in the key to the families is here carried on, and three families are dealt with, the Arctiidae, Agaristidae, and the greater portion of the large family Noctuidae. These three families are held to be very closely related and to have sprung from a common Tortricid ancestor; the lowest group of the Arctiidae—the Nolinæ—and the lowest group of the Noctuidae—the Sarrothripinæ—being very closely allied in form, markings, structure, and the presence of raised buttons of scales on the forewing to some members of the Tortricidae. This affinity of structure and pattern is, however, to be seen also in many genera in the Acontiinæ of the Noctuid series, and the Nycteolinæ of the Arctiid series, bearing out the relationship indicated by *Nola* and *Sarrothripa*; the latter genus has always been held by students of European forms to be an extremely isolated one, but in the oriental region is found to be connected with the main body of the Noctuidae by a continuous chain of genera.

The Lithosid section of the Arctiidae is especially interesting in the oriental region from the many extreme modifications of structure which are presented, especially in the males, which often branch out in many different directions within the same genus; of this *Cyana* is a very good example.

The Noctuidae are primarily divided into subfamilies in accordance with the amount of development and position of vein 5 of the hindwing, which give an excellent character for dividing them into two main groups, with which the number of prolegs developed by the larvæ closely correspond; this being done, Lederer's excellent key to the genera is followed, modified to suit the requirements of the oriental genera, especially in the second group, which has its headquarters in the tropics.

The other family—the Agaristidae—is a small one, and is a development of the higher Noctuidae modified for day-flying purposes.

**Salivary Glands of Hymenoptera.†**—M. Bordas arranges in seven chief groups the salivary glands of *Sphecodes fuscipennis*. The thoracic salivary glands are either pro- or meso-thoracic, the ducts of each half of which fuse under the brain. The post-ocellar glands are much less well developed than in *Apis mellifica*; a number of ducts are given off, and unite in an unpaired canal which opens on the dorsal surface of the anterior part of the oesophagus. The supracerebral glands vary in form and size in different individuals; but they are, as a rule, much more developed in males than females. Their efferent duct describes four or five longitudinal convolutions, enlarges into a vesicle, and opens a little behind the buccal orifice. There is an internal and an external pair of

\* 'The Fauna of British India, including Ceylon and Burma. Edited by W. T. Blanford. Moths.' Vol. ii. by G. F. Hampson, London, 1894.

† Comptes Rendus, cxviii. (1894) pp. 296-9.



mandibular glands, formed of cells with a large central nucleus in the external, and having in the internal a small nucleus. The sub-lingual glands are only separated from the buccal orifice by a delicate chitinous lamella. The maxillary glands are very rudimentary, and look like two small white dots in the midst of the muscular bundles which pass to the anterior pair of maxillæ.

**Reproduction of Wasps.\***—France, like some parts of Britain, having been severely plagued with wasps during the summer of 1893, M. P. Marchal had no difficulty in finding material for an investigation into some points of their reproductive history. Using *Vespa germanica* he found by experiment that the workers lay eggs parthenogenetically; that the eggs thus laid can develop without the aid of the male, and that they produce males only. These results are in entire conformity with those of Siebold on *Polistes*. It was also found that there are among the workers (or, as they are often wrongly called, neuters) a considerable number of individuals which have a predisposition to become fertile; abundance of nourishment determines this fertility. This observation explains how it is that the most fertile period corresponds with the time of year when food is most abundant. As the number of males in a colony increases with the fertility of the workers, there would appear to be a kind of division of labour between these latter and the queen; one producing males, the other females and workers. It is not, however, to be hastily concluded that the queen does not produce males, at any rate towards the end of the summer.

**Termite Societies.†**—Prof. B. Grassi and Dr. A. Sandias have investigated the nature and origin of the Termite society in *Calotermes flavicollis* and *Termes lucifugus*. A *Calotermes* society may include (a) indifferent larvæ, capable of becoming soldiers or sexual members; (b) larvæ and pupæ of sexual members with rudiments of wings; (c) soldier-larvæ and soldiers which may arise from (a) and (b); (d) winged sexual insects; (e) a true royal pair with vestiges of wings; (f) larvæ of "reserve" sexual members and the reserve kings and queens which arise from these. These last larvæ may be developed from (a) or from various stages of (b).

In the *Termes* nest there is a special caste of workers and no distinctive royal pair. The society includes (a) very young indifferent larvæ; (b) larger larvæ and the workers and soldiers to which they give rise; (c) winged sexual animals; (d) various stages of reserve and complementary sexual animals.

The one type, that illustrated by *Calotermes*, is founded by a king and queen, who may be replaced by a pair of reserve royal individuals, i. e. by a "neotenic" couple. The second, less primitive type, illustrated by *Termes*, contains several neotenic couples, while kings are only temporary; in this case the nest arises in a secession from an older colony.

\* Comptes Rendus, cxvii. (1893) pp. 584-7.

† Biol. Centralbl., xiii. (1893) pp. 758-66; Atti Accad. Gioenia Sci. Nat., vi. and vii., 150 pp., 5 pls.



One of the most interesting results concerns the influence of nutrition in producing polymorphism. Thus the reserve sexual members are fed, not only in the larval state but afterwards, from salivary secretion only, a nutritive diet which probably hastens the rapid development of the reproductive system.

**A Stridulating Aquatic Hemipteron.\***—M. Cb. Bruyant finds that the minute *Sigara minutissima*, 1-1.2 mm. in length, produces a very distinct stridulation by working the tarsus (or palette) of the first pair of appendages against the rostrum. Buchanan White has described a somewhat similar arrangement of hairs in *Corixa*, and Schmidt Schwedt has noted the stridulation of *Corixa Geoffroyi*. M. Bruyant also records that *Sigara minutissima* is a casual commensal with *Spongilla lacustris*, like the larva of *Sizyra Spongillæ* and like *Nais proboscidea*.

**Anatomy and Development of Female Genital Armature of Orthoptera.†**—M. Peytoureau has followed the development of this apparatus in *Periplaneta americana*, and finds that the female genital armature belongs exclusively to the eighth and ninth urosternites; the three pairs of genital apophyses, without occupying the position of appendages, arise early in a way which recalls the development of those parts. The other pieces are merely modifications of the sternites or are chitinized membranes. After the last ecdysis the parts which are nearest the orifices of the nidamental gland and the copulatory pouch are often quite the first to become chitinized.

#### β. Myriopoda.

**Chordeuma germanicum.‡**—Dr. C. Verhoeff, in a note on this Myriopod, calls attention to a point of general interest, namely the morphological resemblance of two not homologous, metamorphosed appendages—the second pair of legs of the sixth segment of *C. germanicum* and the second pair of legs of the seventh segment of *C. silvestre*. In other words, almost identical results are obtained with pairs of legs which, originally, were morphologically identical but not homologous, in consequence of almost similar functions and notwithstanding enormous changes.

#### γ. Protracheata.

**Hatching of a Peripatus Egg.§**—Dr. A. Dendy describes the hatching out of an egg of *Peripatus* which had been laid for about seventeen months; he supposes the long period to be due to the eggs having been kept in a very cool room. At any rate, there can now be no doubt that the larger Victorian *Peripatus* lays eggs which may hatch after the lapse of a year and five months.

\* Comptes Rendus, cxviii. (1894) pp. 299-301.

† Op. cit., cxvii. (1893) pp. 749-51.

‡ Zool. Anzeig., xvi. (1893) pp. 477-9.

§ Proc. Roy. Soc. Victoria, 1893, pp. 118 and 9.

## 5. Arachnida.

**Endosternite of *Scorpio*.**\*—Mr. H. M. Bernard compares the endosternite of *Scorpio* with the homologous structure in other Arachnida. He comes to the conclusion that these parts in Arachnids are apodemalous structures due to fusion and compression of the cephalothoracic segments, and later specialized for muscular attachments. He considers that the endosternite of *Limulus* is a derivative of the ventral musclebands, and that it is homologous with that of *Apus*, and not with that of Arachnids; and that it is clear there is no direct genetic relationship between *Limulus* and the Arachnida.

**Anatomy and Relations of Eurypteridæ.**†—Mr. M. Laurie, after giving an account of *Simonia*, *Pterygotus*, *Eurypterus*, and *Stylonurus*, discusses the relations of Eurypterids among themselves, and suggests the following scheme:—

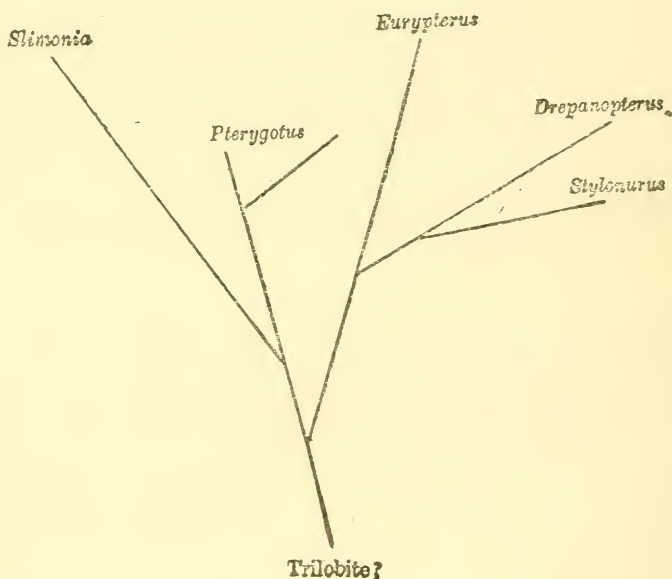

Little can be usefully done in comparing the Eurypterids with Trilobites, for we know very little as to the details of the different appendages of the latter, and what little we do know of their anatomy is based on the more highly specialized forms. There appears to be little reason for regarding the Eurypterids as related at all closely to the Crustacea; to *Limulus*, which is a more primitive type than they, the relationship is not by direct descent, but through a comparatively unspecialized ancestor; this may possibly have been one of the Trilobites.

The relationship of these three groups to "Arachnida" is shown in the table on the next page.

\* Ann. and Mag. Nat. Hist., xiii. (1893) pp. 18-26 (1 pl.).

† Trans. Roy. Soc. Edinb., xxxvii. (1893) pp. 509-28 (2 pls.).

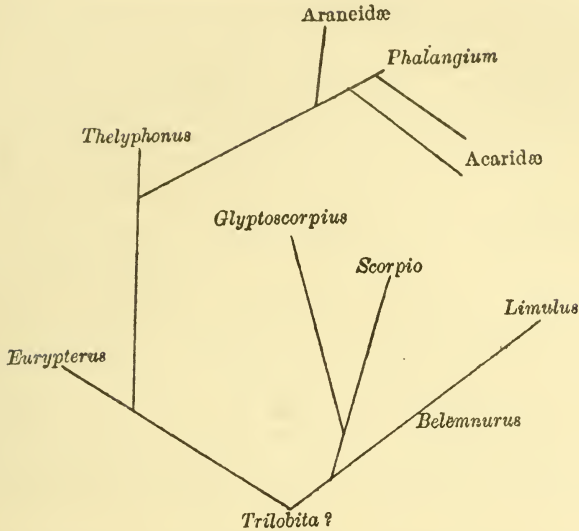

If these views are correct the term Arachnida must have its significance limited or extended; the author proposes the latter, and suggests the following tabular arrangement:—

- Class. Pœcilopoda.
- Sub-class A. Trilobita.
- „    B. Arachnida.
- Order 1. Xiphosura.
- „    2. Scorpionina.
- „    3. Eurypterida.
- „    4. Pedipalpi.
- „    5. Araneæ.

**Pantopoda of Albatross Expedition.\***—M. W. M. Schimkéwitsch describes the Pantopoda collected by the U.S. Fish Commission steamer off the west coast of Mexico and Central America and in the Gulf of California. A useful diagnostic table is given of the characters of seven species and one variety of the genus *Colossendeis*, of which *C. bicincta* and *C. subminuta* are new species. *Ascorhynchus Agassizi*, and *Pallenopsis Californica* are likewise new.

e. Crustacea.

**Spermatogenesis in Decapod Crustacea.†**—M. A. Sabatier has a lengthy memoir on this subject, to which he has given much attention for several years past. He finds the spermatozoa of Decapods to consist of a cephalic cap, which is derived from the atrophied and transformed nucleus, and he regards it as the nuclear appendage; there is a head formed by the vesicle or secondary nucleus, and there are radiate filaments derived from the cytoplasm. This globular or radiate form is,

\* Bull. Mus. Comp. Zool., xxv. (1893) pp. 27-43 (2 pls.).

† Acad. de Montpellier Mem. Sec. Sci., i. (1893) pp. 19-407 (10 pls.).

it is interesting to note, observable also in the spermatozoa of the *Locustidæ*, which are of the filiform type; for, in them, there is a cap and head of similar origin, and a single caudal filament which is derived from the cytoplasm. After briefly summarizing the very divergent views of Schweigger-Seidel and Bütschli, the author explains that the differences are due to the fact that the spermatozoon is a modification of the cell which may present a more varied morphology than is generally supposed; but he is content for the present to promise to prove this proposition.

Our knowledge of the habits of the higher Crustacea is so imperfect that it is difficult to give any answer to the question, what is the aim of the remarkable cellular transformations that occur. It is, indeed, probable that in most of them fecundation is external; if so, we may presume that the male elements are provided with stiff points as fixing organs or hooks, either to seize on the filamental abdominal appendages of the female, or on the surface of the ova. It is to be especially noted that it is in the *Macrura* and *Carida* that the radial filaments are long, fixed, and resisting; in the *Brachyura*, where the abdomen is so folded on the thorax as to form a kind of chamber in which the spermatozoa can be retained, the radial filaments are feeble or even absent.

The modifications of the primitive nucleus and the rise of the secondary one may be due to an early differentiation, the object of which was to make the two nuclear elements, which are found in the nuclei of most cells, independent of one another. If this be so the male reproductive cells of decapod Crustacea may be referred to the primitive type of the ciliated Infusoria.

**Physiology of Decapod Crustacea.\***—M. L. Cuénot has a preliminary notice of the results of his physiological studies, which have been chiefly made with *Astacus fluviatilis*. The process of excretion has been studied by the injection of various colouring matters into the coelom of vigorous animals. The green glands and the branchial glands are both organs of excretion. The two divisions of the labyrinth of the former excrete a certain number of substances, such as acid fuchsin, saffranin, vesuvin, &c., but indigo is only eliminated by the green portion, and helianthin only by the white; this shows that the two parts of the labyrinth have different functions. The whole of the labyrinth has a strong alkaline reaction, but the second is distinctly acid, and eliminates various substances.

The branchial glands, which the author was the first to describe, are so disposed that the blood is forced to pass between their cells. They are made up of cells, with one or several nuclei, which contain products of katabolism identical with those in the cells of the sacculæ. Their action on colouring matters is exactly that of the sacculæ, and they have an acid reaction. They have no excretory canal, but it is probable that they have a function comparable to the liver of Vertebrates, for there is no doubt that they form carcinuric acid. But these branchial glands have also a function in the process of phagocytosis, so that they are exactly comparable to the cells of Leydig in Gastropods.

\* Arch. Zool. Expér., i. (1893) pp. xxi-iv.



By mixing with the food various anilin colours or fat, the author has been able to assure himself that there exist two absorbing organs; the liver, especially at the extremities of its cæca, absorbs soluble bodies, such as peptones and sugars, while the short mid-gut absorbs fatty bodies, which are taken in by the cells in the form of fine droplets, and the whole phenomenon is very similar to the absorption of fat by the cells of the small intestine of Vertebrates.

The "liver" of Decapod Crustacea, besides secreting digestive ferments and accumulating reserve products, plays an important part in absorbing the soluble products of digestion, and in regulating the amount of water in the blood.

**Correlated Variations in *Carcinus Mænas*.**\*—Prof. W. F. R. Weldon has studied the variations of eleven individual parts in a set of 1000 adult females of the shore crab at Plymouth and Naples respectively. The principle which is animating him in the laborious investigation he has undertaken may be gathered from the following passage: "It cannot be too strongly urged that the problem of animal evolution is essentially a statistical problem: that before we can properly estimate the changes at present going on in a race or species we must know accurately (a) the percentage of animals which exhibit a given amount of abnormality with regard to a particular character; (b) the degrees of abnormality of other organs which accompanies a given abnormality of one; (c) the difference between the death-rate per cent. in animals of different degrees of abnormality with respect to any organ; (d) the abnormality of offspring in terms of the abnormality of parents, and *vice versâ*. These are all questions of arithmetic; and when we know the numerical answers to these questions for a number of species, we shall know the direction and the rate of change in these species at the present day, a knowledge which is the only legitimate basis for speculations as to their past history and future fate."

**Crayfish with Abnormal Appendages.**†—Dr. A. Dendy has found a specimen of the Australian Crayfish (*Astacopsis bicarinatus*), which agrees very closely with the European form as regards the thoracic appendages, with small exopodites on three of the ambulatory appendages. He regards their presence as an additional proof of the generally accepted view as to the derivation of the ambulatory appendages from a primitive biramose type.

**Shifting of the Germinal Streak in *Gammarus*.**‡—Dr. R. S. Bergh points out that the germinal streak of *Gammarus pulex* undergoes in its early stages a very remarkable displacement. At first it extends transversely across the oval egg, afterwards it lies obliquely, and finally it assumes its definite position with its median plane in the longitudinal axis of the ovum. The dorsal organ is from the first in the middle of the back, and it remains there unmoved. Its unpaired origin in *Gammarus* must be homologous with its paired origin in *Mysis*; there has been either fusion or splitting. The cell-divisions in the anterior and middle portion of the germinal streak of *Gammarus* show the same

\* Proc. Roy. Soc., liv. (1894) pp. 318-29.

† Proc. Roy. Soc. Victoria, 1893, pp. 160 and 1.

‡ Zool. Jahrb. (Abth. Anat. Ontog.), vii. (1893) pp. 235-48 (1 pl.).

orderliness which Bergh has described in *Mysis*, the equatorial planes of mitoses lying at right angles to the longitudinal axis of the streak, but in *Gammarus* there are no primitive cells (*Urzellen*).

Winter and Summer Eggs of *Moina*.\*—Dr. V. Haecker thus contrasts the development of the winter and summer eggs of *Moina paradoxa* Weism.

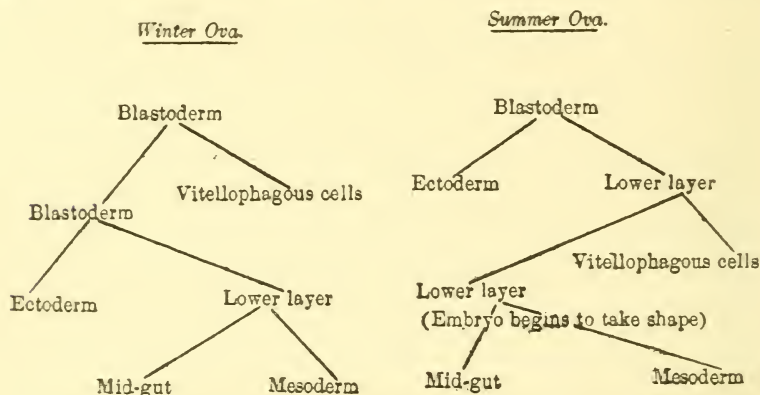

Formation of Germinal Layers in *Moina*.†—Dr. P. Samassa answers some recent criticisms of Prof. Grobben, and urges that the observations he has made on the development of *Moina* are supported by his own on the Cladocera, and by Häcker's statement that even in the winter eggs of *Moina* a lower germinal layer is formed by the growth of a blastozone.

Buccal Apparatus of Cirripedia.‡—M. A. Gruvel calls attention to a hitherto unnoticed arrangement in the mouth of Cirripedes. In *Balanus tintinnabulum* there is internally to the labrum a chitinous piece formed of two symmetrical halves which are fused in the middle line and leave a deep groove on the upper part. The upper edge is thickened, and on the thickening there are fine but rigid rodlets; on each side of the central cavity on each of the halves there are some very strong chitinous setæ, much larger than the rodlets. Small pads, each carrying six to eight rigid setæ, are formed on the lower surface in the line corresponding to the upper groove. These processes appear to form combs which aid in the trituration of food.

The organs which Nussbaum called enigmatic are shown to be true salivary glands, and they have been found in all species that have been examined.

Structure and Functions of Alimentary Canal of *Daphnia*.§—Messrs. W. B. Hardy and W. McDougall find that, though the mesenteron of *Daphnia* appears to be a simple tube, it is divided into three

\* Ber. Naturf. Gesell. Freiburg, vii. (1893) pp. 193-6.

† Zool. Anzeig., xvi. (1893) pp. 434-9.

‡ Comptes Rendus, cxvii. (1893) pp. 858-61.

§ Proc. Cambridge Phil. Soc., viii. (1894) pp. 41-50.

regions; of these the anterior is devoted to the absorption of the products of digestion; in the middle region digestion occurs, and in the hinder region the fæces are found.

The fact that digestion occurs in a region of the gut posterior to that which is occupied in the absorption of the products, is probably without a parallel in the Animal Kingdom, except perhaps among the simplest Coelentera.

The authors give an account of the processes of digestion as studied in specimens fed by pouring beaten yolk of egg, milk, carmine, &c., over the bottom of the dish in which they are living. Owing to the transparent nature of the living *Daphnia*, observation is quite easy. For the details of these observations reference must be made to the original, but it is of importance to note that there is here a profound difference from the higher Crustacea, in so far as the stomodæal and proctodæal portions only take part in the deglutition and defæcation of food; the injecta and ejecta are not lodged in them, but merely hurried through.

The cells of the mesenteron have a hyaline border, which is best developed in the region in which the absorption of fat was found to take place; this corresponds with observations made on other animals. Histological characters of the cell-substance of the cells lining the mesenteron afford further evidence of a differentiation of the epithelium into regions corresponding to those which actual observation of the processes of digestion shows to exist. The cells of the middle region of the mesenteron are specially characterized by the presence under certain conditions of granules which appear to be secretory; so that the cells which bear them are gland-cells, engaged in the elaboration of a digestive ferment or ferments. At the posterior end of the mesenteron the gland-cells secrete remarkably compact groups of granules which appear to glue together the scattered fæcal particles into a compact mass.

The stomodæum consists of a muscular tube lined by a simple low epithelium, which is covered internally by a cuticle; the proctodæum has much the same structure, but its basement membrane is especially well developed. The basement membrane of the gut is the actively contractile organ which brings about peristalsis. It is continuous over the whole mesenteron, and is thin, but very high and very elastic; it has imbedded in it protoplasmic strands which are presumably the contractile elements. These are flattened and are arranged in a longitudinal and a circular series. No traces of nuclei have yet been detected in the basement membrane.

**Ascothoracida.\***—M. Racovitza has an analysis of a memoir by M. N. Knipowitsch on the Ascothoracida; of this group he has studied the *Laura Gerardix* of Lacaze-Duthiers and *Dendrogaster astericola*, a new genus from the White Sea, which inhabits the cœlom of *Echinaster sanguinolentus* and of *Solaster endeca*. In addition to these forms which, like *Petrarca bathyactidis*, are endoparasitic, there is *Sinagoga mira*, which is ectoparasitic. The author regards the group as a suborder of the Cirripedia, the other suborder being composed of the thoracic,

\* Arch. Zool. Expér., i. (1893) pp. xvii.-xix.



abdominal, and apodal Cirripedia, and by the Rhizocephala. The relationship may be shown by the following table:—

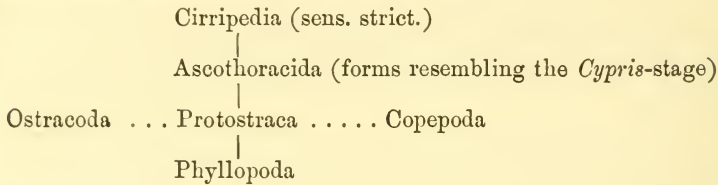

On the descriptions and criticisms of the author Prof. H. de Lacaze-Duthiers\* makes a few remarks. Though denying the name of liver to the large yellow arborescent canals which are connected with the digestive tube, the Roumanian naturalist allows their connection and offers no suggestion as to the function of the parts. What the French anatomist has to say in favour of calling them glands and liver, applies, indeed, to other animals besides *Laura Gerardæ*: "Cette catégorie de glandes digestives, que nous gratifions du nom de foie sans autre raison plausible que leur ouverture dans le tube digestif, et par une habitude qu'il est et sera encore longtemps difficile de faire perdre aux anatomistes."

**Thoracic Legs of Triarthrus.**†—Mr. C. E. Beecher gives some preliminary details as to the structure of the thoracic legs of this Trilobite. Enough has been seen to make it evident that the relations of the Trilobites are with the Entomostraca and Malacostraca. Like the Leptostraca they probably constitute an intermediate type having affinities with the Entomostraca chiefly in the irregular segmentation, and with the lower forms of the Malacostraca (such as Schizopoda, Cumacea and Anisopoda) in the detailed structure of the limbs.

#### Vermes.

##### a. Annelida.

**Supporting Tissues of Nervous System of Chætopoda.**‡—Herr E. Wawrzik finds that in the lowest Chætopoda the supporting tissue which encloses the nervous elements is connected with the subcuticle for the whole length and breadth of the ventral cord. In the higher forms it is connected only by cords, which arise from the tissue around the ganglionic cells. In the highest and in all Oligochæta it is completely cut off from the subcuticle except in the tail. The supporting tissue is to be regarded as a product of the subcuticle, and is comparable to the neuroglia of Vertebrates; it does not only enclose, it also penetrates, the nervous elements.

**Tubes formed by Annelids.**§—Prof. W. C. McIntosh has an interesting article on the homes of Annelids. He remarks that no basket-insect's work is more ingenious, and even the combs of Bees and Wasps, or the nests of the most skilful birds are not more complex

\* Arch. Zool. Expér., i. (1893) pp. xix.-xx.

† Amer. Journ. Sci., xlvi. (1893) pp. 467-70 (3 figs.).

‡ Schneider's Zool. Beiträge, iii. (1892) pp. 107-27 (6 pls.). See Zool. Jahrbesb. for 1892 (1893) Vermes, p. 63.

§ Ann. and Mag. Nat. Hist., xiii. (1894) pp. 1-18 (8 figs.).



examples of workmanship than the tube of *Amphictione*, or that of *Terebella*, with its terminal fringe. Even man, with all his ingenuity, has to make frames for constructing arches and circular buildings, and moulds for circular casts; his cement has to be brought from a distance and carefully manufactured, and he requires good sight and much aid to form his dwelling; some of the most skilful and beautiful formations of these marine Annelids are executed by creatures devoid of eyes, and with a soft and delicate body, whose mortar is secreted by the glands of their skins, and whose inherent instinct enables them to dispense with all artificial aid in the construction of their homes.

**The Genus Polydora.\***—Sig. D. Carazzi describes the Mediterranean species of *Polydora* Bosc. (*Leucodore* Johnston), and discusses briefly the other four known species.

More interesting is his account of the way in which *P. ciliata* and *P. hoplura* attack oysters. The first does serious damage, the second much less. The second species is a true borer, making galleries in the oyster-shell. It may destroy the insertion of the adductor muscle, and thus kill the mollusc. The first species enters when the valves are gaping, and nestling near the mantle-edge accumulates patches of mud which have a disastrous effect. Whitelegge appears to have confused the two species. Neither can be called a parasite, they are rather commensals.

**Amœbocytes and Oogenesis in *Micronereis variegata*.†**—M. E. G. Racovitza finds that the amœbocytes of this worm are not formed in the adult segments of the animal, but are derived directly from the undifferentiated mesodermic mass of a developing segment. This mass is an active centre of mitotic division, and in it there are to be found nuclei which are larger than the rest; these are the nuclei of the oospores. These last begin to divide very early and give rise to ten daughter-cells, each of which forms a small morula-like mass. The nuclei form and a homogeneous nucleolus appears; one of the cells, the future egg, grows very rapidly. Its cytoplasm is charged with droplets of fat, which gradually disappear to make way for small spherical globules. The nucleus and nucleolus have, meantime, both increased in size. The other daughter-cells, the cytoplasm of which has not increased in volume, form a small mass at one of the poles of the egg, and finally disappear.

The mature ovum has a delicate vitelline membrane surrounding a yolk which, in the first state, is formed of apparently homogeneous globules, all of the same size. The germinal vesicle, surrounded by a delicate membrane, has finely granular contents, and in the interior of the nucleolus there is a small spherical vesicle. As the eggs are very large (240  $\mu$ ) in relation to the size of the animal (350  $\mu$  wide), and as there are no segmental organs, the evacuation of the ova must be effected in a special way; they would appear to pass out by an orifice placed superiorly to the anus.

**A Polynoid with Branchiæ.‡**—Under the name of *Eupolyodontes Cornishi* Miss F. Buchanan describes a new Polychæte taken off the

\* MT. Zool. Stat. Neapel, xi. (1893) pp. 4-45 (1 pl.).

† Comptes Rendus, cxviii. (1894) pp. 153-5.

‡ Quart. Journ. Micr. Sci., xxxv. (1893) pp. 433-50 (1 pl.).

mouth of the Congo. It is one of the sub-family Acoëtidae, of which only fifteen species are known, and of these the new form most resembles *Polyodontes gulo*, which should be placed in the new genus. Other genera of the family are critically revised, and an investigation has been made into the characters of the branchiæ of the Amphinomidæ. From this latter it results that within the same genus there are forms with vascular and non-vascular "branchiæ." From this it may be concluded that the so-called branchiæ of Polychæta do not always serve as respiratory organs, and indeed may not do so at all; it is in the sense that we call them branchiæ, on account of their representing the respiratory organs of allied forms, that Miss Buchanan claims to be allowed to apply the same term to the branching processes on the parapodia of *E. Cornishi*. When these outgrowths are not respiratory or mainly so, they may have to do with excretion, serving to store the excretory products, and probably, in the case of *Amphinome* at least, and those forms with blood-vessels immediately underlying the epidermis and with concretions in the epidermis cells, to form them from the blood; in this category the "branchiæ" of *E. Cornishi* are probably to be found.

**Clitellum of Earth-worm.\***—Mr. F. J. Cole throws doubt on the commonly received doctrine that the clitellum secretes the cocoon, and thinks that "it must be admitted that the position of the clitellum points to the conclusion that its only office is to meet the exigencies of an otherwise difficult copulation." An account is given of the histology of the clitellum of *Lumbricus herculeus*, and it is urged that there are no hypodermic cells in it.

**Exotic Earthworms.†**—Dr. H. Ude has made a revision of the earthworms in the collection of the Zoological Institute at Göttingen. In the Rhinodrilid genus *Anteus* he has found two new species, which he calls *A. distinctus* and *A. teres*, as he has also of *Perichæta* (*P. pusilla* and *P. parva*). Among the Acanthodrilidæ he makes a new genus *Geodrilus* (*G. singularis* sp. n. from Danville, Ill.), but he refrains from discussing the generic distinctness of allied genera, or of his new type. Of *Eudrilus erudiens* sp. n., as of his other new species, the author is careful to describe the internal organization.

**Victorian Earthworms.‡**—Prof. W. Baldwin Spencer, in the second part of his preliminary notice of Victorian Earthworms, gives sufficient details to serve for the identification of twenty-two species, of which twenty are new, referred provisionally to the genus *Perichæta*. Most of them are found to have a very limited area of distribution.

**South American Tubificidæ.§**—Mr. F. E. Beddard has a preliminary notice of the Tubificidæ collected in South America by Dr. Michaelsen. Four of the five species belong to *Hesperodrilus*, a new genus characterized by the presence of capilliform setæ only in the dorsal bundles, and of two setæ only in each ventral bundle, as well as the opening of the spermatheca in segment xiii., and the fact that the sperm-duct opens independently of the spermiducal gland into the penis. The first species

\* Zool. Anzeig., xvi. (1893) pp. 440-6 and 453-7 (2 figs.).

† Zeitschr. f. wiss. Zool., lvii. (1893) pp. 57-75 (1 pl.).

‡ Proc. Roy. Soc. Victoria, v. (1893) pp. 1-26 (6 pls.).

§ Ann. and Mag. Nat. Hist., xiii. (1894) pp. 205-10.

of this genus is remarkable for the presence of branchiæ, which are attached a little below the lateral setæ; and in *Branchiura* they are limited to the tail end of the body.

**Structure of Enchytræidæ.\***—Dr. R. Hesse has found two new littoral Enchytræids at Naples, for one of which it is necessary to establish a new genus, which may be called *Parenchytræus* (*P. litteratus*); the other may be called *Pachydrilus litoreus*. A careful study has been made of the musculature, with the result that it has been discovered that all of it, with the exception of the exterior portion, consists of muscle-cells, which belong to the Nematoid type. The septal glands appear to have the function of secreting an adhesive material. Special glands have been observed in those segments which succeed the genital segments; these glands have no lumen, but form essentially a bundle of unicellular glands with separate efferent ducts, which traverse the cuticle; they are, in fact, hypodermic cells modified for some special purpose. This purpose appears to be the secretion of a material which binds the worms more closely together during copulation, and we may therefore call them copulatory glands.

In conclusion the author has a note on the so-called enteric blood-sinus; he thinks that instead of speaking of a sinus supposed to be formed by the outgrowth of the enteric epithelial layer and the exterior muscular layer, we ought rather to consider that we have to do with a vascular plexus which extends over the intestine, and which is comparable to that of *Dero* and some Naims, although not so well developed.

### β. Nemathelminthes.

**Experiments with Ova of Ascaris.†**—Dr. L. Sala has observed the effect of cold on the maturation and fertilization of the eggs of *Ascaris megaloccephala*. The living worms were enclosed in a glass, and this was placed in a freezing mixture, at a temperature of  $+3^{\circ}$  to  $-5^{\circ}$  C., for periods varying from half an hour to two hours. Thereafter the glass was gradually restored to a temperature of  $16^{\circ}$ – $18^{\circ}$  C., and afterwards raised to  $20^{\circ}$ – $30^{\circ}$  C. for a day or two. Among the consequences of this treatment, the following phenomena were frequent. Polyspermy often occurred. The yolk-substance was slightly affected, appearing, for instance, more vacuolated than is normal. The egg-membrane became soft and viscid, and eggs fused together into strange double forms. Sometimes the number of chromosomes was increased, sometimes it was decreased; their form and arrangement was also altered. The typical spindle-like arrangement of the achromatin substance of the directive spindle was more or less altered, and replaced by a variety of complicated and often remarkable forms. Not unfrequently only one polar body was formed, and in many cases the formation was abnormal. In consequence of such modifications as the above, others occurred in the formation of the ovum-nucleus, sperm-nucleus, and segmentation-nucleus. In one case as many as six centrosomata were seen in the fertilized ovum.

\* Zeitschr. f. wiss. Zool., lvii. (1893) pp. 1–17 (1 pl.).

† SB. K. Preuss. Akad. Wiss., 1893, pp. 657–74 (1 pl.).



**Anatomy of Nematodes.\***—Dr. L. A. Jägerskiöld treats of the digestive organs of the Nematode parasites of various fish, birds, and beasts, and with the glands found therein, and also the excretory organs. There do not seem to be sufficient anatomical distinctions to justify the separation of *Peritrachelius* from *Ascaris*.

**Australian and Fijian Nematodes.†**—Mr. N. A. Cobb, in this memoir, which deals chiefly with Australian and Fijian Nematodes, describes eighty-two species, of which about half have not been hitherto described, and he illustrates his descriptions by more than 170 figures. It is stated that the edible part of three bunches of nice-looking celery was cut up as far as it was tender, and on washing gave 200–300 Nematodes, belonging to six species, among which *Mononchus longicaudatus* was abundantly represented. A key is given to the species of *Mononchus* and of *Diplogaster*, another free-living, not marine genus. For *Tripyla* three keys are offered. For all these, as for a number of other genera, the species are fully described, and that in a way that will make the accounts of interest to the morphologist as well as to the systematist or to the student of the enemies of plants.

#### γ. Platyhelminthes.

**Turbellaria of 'Albatross' Expedition.‡**—Mr. W. M. Woodworth states that the Turbellaria collected by the 'Albatross' were few in number; *Planocera pellucida* being now found in the North Pacific, and having been known from the Indian Ocean and North and South Atlantic, has the widest distribution of any pelagic Planarian now known. *Stylochoplana californica* is certainly, and *Prostheceræus panamensis* probably new.

**Land Planarians from Tasmania and South Australia.§**—Dr. A. Dendy has notes on some new or little-known Land Planarians. He finds that the Tasmanian form, which he referred to *Geoplana alba*, has no eyes, and he proposes, therefore, to call it *G. typhlops*. Special attention is drawn to the variations in marking exhibited by *G. fletcheri*; these, though very conspicuous, are all clearly due to the intensification or suppression of parts of what may be regarded as the typical pattern of the species; indeed, as far as the author knows, this statement holds good for all Land Planarians.

**Emea lacustris.||**—Dr. G. du Plessis gives an account of the organization and mode of life of this freshwater Nemertine, which he has discovered in and near Geneva. It is one of the Enopla, and has in many points a close resemblance to *Tetrastemma*, but agrees exactly with Leidy's genus *Emea*; indeed, its only important difference from the North American *E. rubra* is the presence of only two instead of four cephalic pits. From *Tetrastemma* the points of difference are the varia-

\* Akad. Afhandl. Stockholm, 1893, pp. 1–86 (5 pls.). See Centralbl. f. Bakteriöl. u. Parasitenk., xv. (1894) pp. 125 and 6.

† 4to, 1893, Sydney, 59 pp., 7 pls. Reprinted from the Macleay Memorial Volume.

‡ Bull. Mus. Comp. Zool., xxv. (1894) pp. 49–52 (1 pl.).

§ Proc. Roy. Soc. Victoria, 1893, pp. 178–88 (1 pl.).

|| Revue Suisse de Zool., i. (1893) pp. 329–57.



tion in the number of the eyes, the fusion of the proboscis and œsophagus in front of the mouth, and the frontal (not ventral) position of the mouth.

**Structure and Life-history of Tæniæ.\***—Dr. v. Linstow describes *Tænia ursina* sp. n. from *Ursus arctos*; *T. (Davainea) Struthionis* Houttoyn from *Struthio molybdophanes*; and *T. serpentulus* Schrank from *Corvus corone*, &c. In the second, as in other species of *Davainea*, the ova remain in the ovaries, where the spermatozoa and yolk-cells are brought to them, and the shell-substance is secreted by the ovaries themselves, there being neither "ootyp" nor shell-gland. The cysticerci of *T. serpentulus* were found in the dung-beetle, *Geotrupes sylvaticus*.

### 5. Incertæ Sedis.

**Enteropneusta.†**—Prof. J. W. Spengel has published his long looked-for monograph on *Balanoglossus* and its allies. The old and wide generic name is now more strictly limited, and, in addition to it, *Ptychodera*, *Schizocardium*, and *Glandiceps* are recognized. As to the significance of Della Chiaje's original name, about which there has been much discussion, the author comes to the conclusion that the illustrious Italian naturalist desired to give a name which should signify that the worm was like a *Balanus* anteriorly, and an ox's tongue posteriorly.

Nineteen species in all are recognized—*Ptychodera minuta* Kow., *P. sarniensis* Koehler, *P. aperta* sp. n., *P. clavigera* D. Ch., *P. gigas* F. Müller, *P. aurantiaca* Girard, *P. erythræa* and *P. bahamensis* spp. nn., and *P. flava* Esch.; *Schizocardium brasiliense* and *S. peruvianum* spp. nn.; *Glandiceps talaboti* Marion, *G. Lachsi* Marion, and *G. abyssicola* sp. n.; *Balanoglossus Kuppferi* Will.-Suhm, *B. canadensis* sp. n., *B. Kowalevskii* A. Ag., *B. Mereschkowskii* N. Wagner, and *B. sulcatus* sp. n.

A comparative table is given of the generic characters of the four divisions adopted, and it is suggested that provisionally the Ptychoderidæ should be further subdivided, so as to include, in addition to *Ptychodera*, the genera *Tauroglossus* and *Chlamydothorax*.

The Ptychoderidæ are all littoral; *Schizocardium* is as yet only known from either side of the South American continent. *Glandiceps* is not only known from the Mediterranean and from Japan, but contains the only deep sea form (2500 metres) and is from the Atlantic. *Balanoglossus* appears to be confined to the northern hemisphere, and extends, indeed, as far north as the White Sea and Greenland; *B. sulcatus* is from Japan, and *B. canadensis* from the St. Lawrence.

The second section of the work is devoted to ontogeny, and the third to the special morphology of the Enteropneusta; the fourth deals with the general morphology of the group, and the last with its affinities. A critical study results in the conclusion that, in none of the points in which the Tunicata differ from the Vertebrata do they approach the Enteropneusta, and the doctrine of the affinity of the last with the Chordata finds no support from this side. Even if we allow that there are some points which justify a belief in a relationship between Enteropneusta and Annelids, that relationship cannot be close. The differences

\* Arch. f. Mikr. Anat., xlii. (1893) pp. 442-59 (2 pls.).

† 'Fauna und Flora des Golfes von Neapel, &c., xviii. Enteropneusta,' Berlin, 4to, 1893, 758 pp., 37 pls.

are so great that one can only imagine a connection at the root; one supposes, that is, that there arose from the Platodes, by the formation of a metameric cœlom, forms which became, some Annelids and some Enteropneusta.

In Prof. Sprengel's opinion no relationship can be admitted between the Enteropneusta and the Nemertinea, and there does not appear to be any better case for the Echinoderma. If we allow there is an affinity to *Cephalodiscus* we are not much advanced in our search, for with what other animal is *Cephalodiscus* itself certainly allied?

We cannot refrain from again expressing our admiration for the plates in this fresh volume of Dr. Dohrn's great faunistic monographs.

**Larva of *Balanoglossus*.**\*—Prof. W. E. Ritter has a notice of a new *Balanoglossus* larva from the coast of California; it is distinguished from all known Tornariæ except the Bahama form by the possession of tentacles on the longitudinal ciliated bands, but they differ both in number and length.

The most noteworthy points in internal structure are that, like some species, but unlike the New England form, the œsophageal evaginations which are the beginnings of the first pairs of gills do not appear until metamorphosis sets in; and that there is in the floor of the œsophagus a band of high epithelium. The author thinks that this is, functionally, at any rate, comparable to the endostyle of *Amphioxus* and the Tunicates. The development of the dorsal nerve-cord is more on the lines of *Amphioxus* than of the *Balanoglossus* larva described by Bateson.

#### Echinoderma.

**Recent and Fossil Starfishes.**†—Herr B. Stürtz finds that palæolithic starfishes are, in general, provided with the characters which are now used for dividing recent forms into families and genera. Most of them, however, unite in themselves characters which are now distributed among several genera or even several allied families. There has, therefore, since then been not only further development, but still further differentiation of the families and genera. The Encrinasteriæ, with their alternating ambulacral plates, do not otherwise contain any lower types than the palæozoic Eustelleridæ. The importance of the alternating arrangement of the ambulacral plates is marked by the fact that it is seen also in palæolithic Ophiurids. A characteristic of scarcely less importance for certain Palæostelleridæ is the actual position of the madreporite. As this obtains in Ophiuroids it is clear that both divisions are to be referred to a stem-form, which had the madreporite, or its equivalent, on the ventral surface. The palæolithic Starfishes are not allied to recent littoral forms, but to those that are exclusively abyssal. The fossil fauna of Bundenbach is particularly rich in forms which stand near recent abyssal species.

Another striking fact is the wealth of palæolithic deposits in Starfishes which unite the characters of the recent Pterasteridæ (Hymenasteridæ) and Brisingidæ. Allies of the Archasteridæ, Astropectinidæ, Pentagonasteridæ, Pentacerotidæ, Gymnasteriidæ, Linckiidæ,

\* Zool. Anzeig., xvii. (1894) pp. 24-30 (2 figs.).

† Verh. Nat. Ver. Preuss. Rheinl., l. (1893) pp. 1-92 (1 pl.).

Solasteridæ, Pterasteridæ, Echinasteridæ, Asteroiidæ, and Brisingidæ are to be found in palæozoic deposits, but as yet there are no indications of the Porcellanasteridæ, Antheneidæ, Zoroasteridæ, Stichasteridæ, Heliasasteridæ, or Pedicellasteridæ. While adopting Mr. Sladen's classification of Asteroidea, Herr Stürtz points out that, for palæontologists, neither the presence of papulæ nor of papular pores is of service; even more rarely can he say whether the pores were confined to one surface of the body. This character is of no more use than Perrier's pedicellariæ. It is suggested that, for the palæontologist, characters drawn from the mouth-parts would be of greater service. With regard to the presence (Phanerozonia) or absence (Cryptozonia) of evident marginal plates it is remarked that the intermediate forms render this character of comparatively little service. The author thinks that under these circumstances the general structure, and especially that of the hard parts, is of much greater value for palæontologists, and he laments that our knowledge of these facts in recent Starfishes is still so incomplete.

While Sladen holds that the Phanerozonia are older than the Cryptozonia, Perrier holds exactly the opposite; our author thinks Sladen's view is probable, but finds that the question is not to be settled by palæontology; the oldest layers, as far as the Lower Devonian, contain all the types and even the so-called intermediate forms of both, and the older and the younger groups.

No facts are known to Herr Stürtz which would justify the conclusion that pre-Jurassic Asteroids had the great regenerative and fissive power of their recent descendants.

What is true of Asteroids appears to be also true of Ophiuroids; the palæozoic forms are not so different to the recent that they should be classified apart from them.

Asteroidea of the 'Travailleur' and 'Talisman' Expeditions.\*—Prof. E. Perrier, in a handsome and well-illustrated volume, gives a full account of the Starfishes collected by these two deep-sea dredging vessels. He finds that the deep-sea Asteroids do not present any type the equivalent of which is not to be found in shallow waters. To find, however, the littoral representatives of the deep-water fauna it does not suffice to mount to a definite region, for example, towards the north; it is necessary to go a little everywhere. As the author has already urged, the animals of great depths may be considered as animals descended from the free surface of the ocean or shores, but that the shores of all regions of the globe seem to have furnished their contingent to this emigration.

An account is given of the general anatomy of the skeleton, and a number of fresh descriptive terms are introduced; Mr. Sladen's classification is submitted to close examination, and some of its characters are regarded as artificial, while reasons are given for thinking that the Brisingidæ and allied forms are the least, not the most differentiated of the Starfish stock.

After some discussion a series of five orders is adopted; these are called Forcipulata, Spinulosa, Velata, Valvata, and Paxillosa; the first begins with the Brisingidæ, and the last ends with the Archasteridæ.

\* 'Expeditions Scientifiques du 'Travailleur' et du 'Talisman' . . . Echinodermes,' Paris, 4to, 1894, 431 pp., 26 pls.



The so-called teeth are pressed into the service of classification in a quite new way.

In the three expeditions of the 'Travailleur' and the single one of the 'Talisman' there were collected about 630 Starfishes; these belonged to 78 species, 61 of which were then new. The expeditions ranged from 26 to 5005 metres in depth, from 46° to 15° of N. latitude, and 6° E. to 30° W. in longitude.

**Enteric Canal of Echinoderma.\***—Dr. J. Frenzel has examined the enteric epithelium of various common Echinoderms, and finds that the cells are always cylindrical, and have characteristic brownish contents; in some cases there are found between these cells migratory elements, which are principally secretory in character. When these are absent the cylindrical cells, which are always absorptive, are also secretory. No part of an Echinoderm gut can be said to be hepatic in function.

**Organogeny of *Asterina gibbosa*.†**—Mr. E. W. MacBride gives a preliminary account of his observations on the development of this Starfish, in which he deals especially with the later larval stages and the metamorphosis. He finds that the cœlom becomes segmented, and that the arrangement of its divisions strongly recalls that of *Balanoglossus*. The right and left hydrocœle are compared to the collar cavities of *Balanoglossus*, and support for this view is found in the structure of *Cephalodiscus*, where the collar cavities are prolonged into long, pinnately branched arms, comparable to the radial canals of the water-vascular system of Echinoderms, with their rows of tube-feet.

There is no hæmocœle in *A. gibbosa*, all cavities lined with epithelium being derived from the cœlom. The so-called dorsal organ is nothing more than an ingrowth of the left posterior cœlom into the septum separating the posterior cœlomic cavities from the axial sinus. It soon becomes solid, and from its upper end in the adult the genital rachis grows out. As the genital organs are formed as local swellings of this rachis, the ultimate origin of the sexual cells in *Asterina*, as in Vertebrates and Annelids, is cœlomic epithelium.

Ludwig, who discovered that the preoral part of the larva becomes a special locomotor organ, failed to observe that it is connected with a fixing organ or stalk. This arrangement persists for some time after the larva has acquired the adult form, for it is for a time unable to use its tube-feet, and when displaced from its attachment floats helplessly about.

In *Antedon*, which is likewise stalked, there is an excessive growth of the ventral surface, which rotates mouth and hydrocœle backwards and upwards away from the stalk, with the result of placing the mouth in a favourable position to catch pelagic prey. In *Asterina*, however, the body is flexed ventrally on the stalk, so that the ends of the hydrocœl meet round it, and the mouth is approximated to the substratum. The general conclusion to be drawn is that the abactinal plates of *Asterina* and *Comatula* are not comparable with each other, and that all conclusions based on the supposed homology of the dorsocentral in

\* Arch. Anat. and Physiol., Physiol. Abth., 1892, pp. 81-114 (2 pls.). See Zool. Jahresber., 1892 (1893) Echinoderma, p. 5.

† Proc. Roy. Soc. Lond., liv. (1894) pp. 431-6 (4 figs.).



Echinoids and Asteroids and that in Crinoids are incorrect. This is revolutionary indeed, in face of the speculations and generalizations of the last twenty years.

Bipinnariæ from the English Channel.\*—Mr. W. Garstang records the discovery near Plymouth of Bipinnaria-larvæ of the type described by Sars in 1846, and, since then, not known to have been found. Those which form the basis of the present paper agree with Sars' *B. asterigera* in the great development of the pre-oral lobe, but they resemble the commoner type and differ from Sars' larva in the less concentrated arrangement of the paired ciliated arms. So far as the author's experience goes, the mode of swimming is quite unique. During locomotion, which is usually in an upward direction, the pre-oral lobe is anterior, and the body itself is held quite rigid. Movement is effected by seemingly indolent, but regularly repeated strokes of the dorsal arm of the pre-oral lobe in an antero-posterior direction over the back of the larva. The number of strokes during three consecutive minutes were 80, 81, 81. The ventral arm and all the paired processes of the body were entirely inert, but the arm may play the part of an anterior rudder.

Mr. Garstang points out that a great development and specialization of the pre-oral lobe for locomotive purposes is found in *Balanoglossus*, though all traces of ciliated bands are lost in the course of its development from *Tornaria*. The existence of Asteroid larvæ in which the pre-oral lobe is specially developed for the purpose of swimming in the open sea seems to the author to point to the idea that the pelagic ancestor of *Balanoglossus* was also provided with a muscular, pre-oral, flexible lobe, bounded by the two ciliated bands, and used for swimming. In *Balanoglossus*, after the adoption of life on the sea-bottom, the pre-oral lobe, developed under pelagic influences, was used for moving about in the mud, where it rapidly lost its primitive ciliated bands.

Holothurians of North Atlantic.†—Dr. E. von Marenzeller has published a detailed account of the Holothurians collected by the Prince of Monaco in the Bay of Biscay and off the Azores; to the preliminary notice of this paper we have already called attention. Fourteen species in all were collected. The new species *Holothuria lentiginosa* was represented by a single example, which was 160 mm. long; it is allied to *H. signata*, *H. Polii*, &c. The examples of *H. verrilli* show how much the cabinet naturalist is dependent on the collector; specimens simply put into alcohol measured 110 mm. long, and had the skin deeply creased; while others, which had been injected with alcohol after ligation of the vent, were 200 mm. long and had the skin smooth. This species appears to be closely allied to *H. intestinalis*.

*Benthodytes janthina*, though presenting signs of close affinity to *B. abyssicola*, is certainly distinct from it; the single specimen found was a female. A study of *Peniagone azorica* serves to show that the genera *Elpidia* and *Peniagone* should be united. There are some interesting notes on the much misunderstood species *Cucumaria Montagu*. The discovery of *Chiridota abyssicola* at a depth of 2870 metres is the

\* Quart. Journ. Micr. Sci., xxxv. (1894) pp. 451-60 (1 pl.).

† 'Résultats des Campagnes Scientifiques, &c.,' vi. Monaco, 4to, 1893, 24 pp., 2 pls.

first indication that this genus is found in deep waters. The plates deserve a special word of praise.

#### Cœlentera.

**Octineon Lindahli.**\*—Dr. G. H. Fowler gives an account of a remarkable Anthozoon, the investigation of which by Dr. Carpenter and by Prof. Moseley was, in each case, stopped by death. The only known specimens were dredged by the 'Porcupine' in 1870, not far from Cape St. Vincent, in 364 fathoms.

The whole exterior is densely covered by particles of micaceous sand, Foraminifera, and sponge-spicules, and dissection was a matter of difficulty. Notwithstanding its Zoanthid habit of forming a sandy incrustation, Octineon is a Hexactinian, for it has twelve primary mesenteries, but of these only eight carry the extraordinarily powerful retractor muscles, and these are arranged in the manner characteristic of the Edwardsiæ. We have, then, here an Actinarian with the characteristic habit of a Zoanthid, the twelve mesenteries of a Hexactinian, and the eight muscles of an Edwardsia.

The structure of the retractor muscles is so unlike that known in any other Anthozoon, that a new family—Octineonidæ—characterized by a specialization of the retractor muscle-fibres into a muscle separate, or nearly so, from the mesentery, must be established.

The author proceeds to criticize the phylogenetic views of Boveri and M. Murrich, both of which regard the Edwardsiæ as the modern representatives of the starting point from which all existing groups of Anthozoa have been derived; it is pointed out that there are three possible lines of descent, though it is allowed that it is almost impossible to deny that an eight-rayed ancestor is common to the several groups of the Anthozoa. The Aleyonaria and Edwardsiæ are permanently eight-rayed, while the Madreporaria, Hexactiniæ, and Ceriantheæ all pass through an eight-rayed stage; this arrangement may be reasonably derived from a four-rayed condition. Indeed, the evolution of a Scyphostomoid ancestor into the Lucernariæ, the Anthozoa, and the Scyphomedusæ is very generally accepted.

It is easy to conceive that, the mesenteries having the threefold function of carrying digestive, reproductive and muscle-cells, a special localization of digestive cells on ridges would lead to a concentration of reproductive cells in their neighbourhood for better nutrition; while the general musculature of the body-wall, probably both at first circular and longitudinal, might, when carried out along the ridge, become specialized on one side into retractor (longitudinal), and on the other side into protractor (circular) muscles.

The suggestion must be borne in mind that it is possible that the group Hexactiniæ as now constituted includes ten or more groups, not clearly distinguishable in the present state of our knowledge.

**Irish Hydroida.**†—Mr. J. E. Duerden enumerates forty-six species, of which fourteen are new to Ireland and some are rare. Among these may be mentioned the Atractilidæ, five species of these minute forms

\* Quart. Journ. Micr. Sci., xxxv. (1894) pp. 461-80 (2 pls.).

† Proc. R. Irish Acad., iii. (1893) pp. 137-50.

having been found. The discovery of *Diphasia fallax* in the south of Ireland gives this species a much wider southern range than has hitherto been assigned to it.

**Australian Hydroids.\***—Mr. W. W. Bale has some further notes, chiefly on specimens collected at Port Phillip; nine, inclusive of Prof. Spencer's *Plumularia procumbens* and *Clathroozon wilsoni*, were found to be new. The genus *Halocordyle*, not hitherto known to occur in Australia, was represented by a single specimen. The author thinks that the presence of a secondary envelope in *Diplocheilus mirabilis* is illusory, and that the genus should be sunk in *Kirchenpaueria*.

#### Porifera.

**Development of Cornacuspongiæ.†**—Dr. O. Maas has an important paper on the development and metamorphosis of Cornacuspongiæ. The first part of his memoir describes the metamorphosis of *Axinella cristagalli* sp. n., the development of the larva of *Myxilla rosacea* O. S., the metamorphosis of the larva of *Gellius varius* Bwk., the development of the larva of *Chalinula fertilis*, and includes notes on the development of the horny sponges (*Hircinia variabilis* and *Euspongia officinalis*) and of *Spongilla*.

It will be more profitable to restrict our attention to the general results. Dr. Maas is quite convinced that the Sponges are true Metazoa, probably descended from diploblastic ancestors, but they are markedly divergent in that the flagellate locomotor cells of the embryo come to lie internally. The Sponges are in no case Cœlentera, for their layers are not homologous with the inner and outer layers of Cœlentera, and their canal system is absolutely divergent, as also is the differentiation of the tissues after sedentary life begins.

The more we know of sponges, the more variety is discovered in their ontogeny, as is perhaps not unnatural in so primitive a phylum. Apart from the larvæ of the horny sponges and Spongillidæ which are completely flagellate, the Cornacuspongiæ show two types of larva, which in no case have flagella at the posterior pole. In *Esperia*, *Myxilla*, *Desmacidon*, *Clathria*, *Dictyonella*, and *Axinella*, the flagellate cells simply stop towards the posterior end; in *Reniera*, *Chalinula*, *Gellius*, *Pachychalina*, and *Toxochalina* the flagellate cells end in a distinct ring of large cells with large flagella. There are also characteristic differences of pigmentation between the two types. It is supposed that in the completely flagellate larvæ, apparently not heteropolar like the rest, the flagellate annulus of the second type has simply been extended backwards.

After considering such difficult cases as that of *Sycandra*, and comparing the development of Sponges with that of Cœlentera and other Metazoa, Maas comes to the conclusion that one must choose between denying all homology between the germinal layers of sponges and those of other animals, and regarding the flagellate cells as representing the ectoderm and the large cells the endoderm. He regards the formation of the two

\* Proc. Roy. Soc. Victoria, 1893, pp. 93-117 (4 pls.).

† Zool. Jahrb. (Abth. Anat. Ontog.), vii. (1893) pp. 331-448 (5 pls.).



layers in siliceous sponges as an "epibolic pseudogastrulation," and the immigration of flagellate cells, subsequent to settling down, as representing the true gastrulation. His memoir is one which none interested in embryology can afford to overlook.

**Systematic Position of Placospongia.\***—Prof. R. von Lendenfeld finds that the resemblance between the *Geodia-sterraster* and the *Placospongia-sterraster*, on account of which Sollas ranked *Placospongia* among the Tetractinellids, is superficial. The sterrasters differ both in structure and development. It seems, therefore, that Keller is right in referring the genus to the Monactinellida, and placing it near the Spirastrellidæ.

#### Protozoa.

**Studies on Protozoa.†**—Dr. F. Blochmann brings together a number of short notes on Protozoa. The first concern *Pelomyxa*. On the surface of this well-known Rhizopod he observed, on living and preserved specimens, numerous fine threads, 10–15  $\mu$  in length, not unlike attached bacteria, but longer and finer. Observing the median forward streaming of the plasm, and the external current of water (as marked by suspended carmine), Blochmann observed that the threads also moved forward at the same rate, apparently borne by the streaming of a very fine hyaline cortical layer. This observation also corroborates an *à priori* conclusion of Bütschli's.

Every day for about a week, the author noticed that 60–80 specimens of *Pelomyxa* crept during the night from their shelter in the mud up the glass sides of the aquarium, and retired again when the daylight became intense. The daily journey was about 20 cm. It is likely that putrefaction in the mud drove them out, as it is certain that the light drove them back. When twigs of *Elodea* were placed in the water, and made the aquarium more wholesome, the migrations ceased. Besides *P. villosa*, *P. viridis*, and *P. palustris*, Blochmann recognizes a fourth species which he calls *P. Greeffi*. He has also an interesting note on the way in which *Amœba proteus* catches the lively *Cyclidium glaucoma*, often at the rate of 3–5 in 10–15 minutes!

The author then notes the occurrence of karyokinesis in *Polytoma uvella* and *Monas vivipara*; and describes a new heterotrichous Infusorian (*Cœnomorphina Henrici* g. et sp. n.), nearly allied to *Cœnomorpha*, in which he was able very clearly to observe the contractile vacuole emptying itself externally at the hind end of the cell, where a depression seemed also to serve at once as an anus and as the canal of the vacuole.

**Microscopic Vivisection.‡**—Dr. A. Gruber has published under this title an interesting popular lecture in which he describes the division and conjugation of *Stentor coerules* and its behaviour when cut into pieces. A portion of the necklace-like nucleus is essential if a fragment is to regenerate the whole; it is the nucleus which gives the cell its "physiognomy"; but the behaviour of a fragment shows that each particle of protoplasm has "its own independent Psyche," and that the

\* Biol. Centralbl., xiv. (1894) pp. 115–6.

† Tom. cit., pp. 82–91 (3 pls.).

‡ Ber. Nat. Ges. Freiburg, vii. (1893) pp. 47–67 (13 figs.).



nucleus is not the psychological centre of the cell. These and other conclusions based on experiment are vividly restated.

**Parasitic Vorticellæ.\***—In some recent cultivation experiments Herr Lindner noted the development of an iridescent scum on the surface of the medium, and in this observed small round bodies endowed with lively movements. They were about three to six times less in size than a red corpuscle, and multiplied with extraordinary rapidity. These forms were often associated with *Bacilli*, *Spirilla*, &c., and if these latter predominated, then only the lower developmental stages of *Vorticella* were found, that is, coccoid and cercomonad forms, which like bacteria, appeared to increase independently by fission. When the round microbe had the upper hand then the development of large *Vorticellæ* proceeded apace. The very great resistance of *Vorticellæ* to drying enabled the author to procure pure cultivations by immersing wood splinters in the scum and allowing them to dry for four to even twelve weeks, by which time the Schizomycetes were dead. By the same method the author also obtained pure cultivations of *Vorticellæ* in their lowest stages of development. These lowest developmental stages were also found in pig's blood-serum, and by cultivating in dilute meat-broth countless *Vorticellæ* were obtained in seven to eight days. The author observed that living unstalked *Vorticellæ* meander for considerable distances in the intermuscular connective tissue of animals before they encapsule themselves.

In the earlier part of the author's paper are recapitulated his previous observations, one of which in connection with parasitism may be mentioned. The author says he found *Vorticellæ* very frequently in nasal and pharyngeal catarrh, and also in the hairy scalp of man, where they produce eczema. By inoculating *Vorticella* fluid on the scalp he succeeded in producing an eczematous eruption, accompanied by lymphangitis and swelling of the lymphatic glands.

**Balantidium viride, an Infusorian Pathogenic to Pigeons.†**—Herr P. Willach describes a disease of pigeons in which the principal post-mortem appearances were a greyish-red hepatization of the lungs, the adjacent bronchi being filled with a granular detritus. In the liver and muscles numerous small yellow nodules were found. Parasitic Infusoria were discovered in all these necrotic foci. In shape they were oval, and in size somewhat larger than the bird's red corpuscle. There was a faintly granular nucleus, a bright nucleolus, and the protoplasm, except of the nucleus, had a decided green colour. The whole body was covered with short thick cilia, and these were clearly visible even about the mouth, which was a triangular depression at one extremity. No anus was observed. Slow movements were visible in all the parasites when inspected under the Microscope.

The author considers these organisms to belong to the subclass Holotricha, and designates them on account of their resemblance to *Balantidium* and of their green colour as "*Balantidium (Paramœcium) viride.*"

\* Deutsche Med. Zeitung, 1893, No. 82. See Centralbl. f. Bakteriol. u. Parasitenk., xv. (1894) pp. 84-6.

† Arch. f. Wiss. u. Prakt. Tierheilkunde, xix. (1893) Nos. 1 and 2. See Centralbl. f. Bakteriol. u. Parasitenk., xv. (1894) pp. 83-4.

Besides the foregoing, still larger individuals of a brownish-green hue were observed. These were closely beset with tubercles, on which were cilia, and at one extremity was a triangular oral aperture. Whether these forms are to be classed with *B. viride* is left undecided.

*Myxotheca arenilega*.\*—Under this name Herr F. Schaudinn describes a new marine Rhizopod: it was discovered by the naked eye, owing to its pseudopodial tufts being several centimetres long. It is amoeboid in form and surrounded by a gelatinous investment which may be naked or have sand-grains and other foreign bodies attached to its outer surface; moreover, it has reticular pseudopodia and a nucleus which may be from 39–75  $\mu$  long. The species have been obtained from Rovigno and from Naples.

With regard to its systematic position the author reminds us that Neumayr, who was the first to try to fix the natural affinities of the Foraminifera, showed how probable it was that those with calcareous tests were derived from agglutinating forms. Of these latter the most primitive appear to be Astrorhizidæ, of which the simplest are *Psammosphæra* and *Sorosphæra*. Herr Schaudinn thinks that he has sufficient proof that *Myxotheca* is lower than either of these, and he concludes, therefore, that it is the most primitive of extant Foraminifera, and that it is possible that it or some allied form served as the starting point for the whole group of Astrorhizidæ.

In a postscript the author adds that the study of a low Foraminifer has revealed to him developmental stages which have a certain resemblance to *Myxotheca*. The possibility, therefore, that the new form is an incompletely developed arenaceous Foraminifer must not be lost sight of.

*New Gregarine in Algerian Acrididæ*.†—M. L. Léger describes, under the name of *Clepsidrina acridiorum*, a new Gregarine which differs in important characters from *C. Munieri* which infests *Timarcha*, and *C. macrocephala* which is found in *Gryllus sylvestris*. It was found in abundance in the intestinal tract of species of *Pamphagus* and *Truxalis* which live in Algeria.

*Polysporella*.‡—Dr. P. A. Dangeard discusses the nature of *Polysporella Kützingii*, which Zopf ranked among the Monadineæ, beside *Colpodella*, *Pseudospora*, *Protomonas*, and *Diplophysalis*, distinguishing it by the occurrence of several spores in the sporocysts. But Dangeard finds that this alleged form consists (a) of the normal sporangial state of *Pseudospora Nitellarum*, and (b) of modifications due to the presence of *Nuclearia simplex* as the parasite inside the sporangia. There is, in short, no such genus as *Polysporella*.

*Monocercomonas Hominis* and *Amœba coli*.§—Dr. A. Epstein examined the contents of the alimentary canal of a number of children suffering from diarrhœa, and in twenty-six cases found Protozoa. The contents were obtained by means of a hollow sound which was passed

\* Zeitschr. f. wiss. Zool., lvii. (1893) pp. 18–31 (1 pl.).

† Comptes Rendus, cxvii. (1893) pp. 811–3.

‡ Botaniste, 3 série, fasc. 5 (1893) pp. 205–14 (1 pl.).

§ Prag. Med. Wochenschr., xviii. (1893) pp. 463, 475, 486 (2 figs.). See Centralbl. f. Bakteriol. n. Parasitenk., xiv. (1893) pp. 781–5.

up the gut. The pear-shaped parasites, at the thicker end of which were two flagella, were 0·006–0·024 mm. long, and exhibited lively oscillating movements. The numbers varied in the same child from day to day, and on the whole were more numerous the more liquid the stool. In formed motions they are infrequent and only found on the surface.

Neither conjugation, nor fission, nor resting stages were observed. Cultivations in water, in pepton, and meat broth failed. Diarrhœas associated with the presence of *Monocercomonas* are indistinguishable from diarrhœas of other origin; as a rule there are numerous and copious evacuations which resemble pea-soup or milk-coffee; their reaction is usually acid, though sometimes alkaline. The course of the disease may be acute or chronic, and the parasite may be observed for a series of weeks. The connection between the parasite and the disease is supported by the observation that six children inhabiting one room were almost simultaneously affected, the source of infection probably being drinking-water.

In five of the twenty-six cases *Amœba coli* was also observed; its presence apparently did not aggravate the disorder. In fresh preparations *Amœba coli* lived longer than *Cercomonas*.

**Supposed Cancer Parasites.\***—Drs. G. Massari and E. Ferroni are convinced that all the appearances described as being cancer bodies and parasites of cancer belonging to the Sporozoa are nothing more than the products of pathological changes in the tissues, and therefore originate directly from epithelial cells and their nuclei. This view is supported by the observation that similar appearances can be demonstrated in non-cancerous tissues.

**Parasitic Cell-Inclusions in Sarcomatous Tissue.†**—Dr. A. D. Pawlowsky examined fourteen sarcomata for parasitic cell-inclusions. He found in more or less abundance polymorphic bodies about the size of a *Macrococcus*, usually round, but sometimes oval. They lay either free in the cell-plasma, or more rarely were surrounded by a single or even doubly contoured capsule. Sometimes they were met with between the cells. As a rule the cell-nucleus, the capsule, and the contents stained differently and presented the phenomena of metachromatism. The author considers these forms to be true parasites, to be Microsporidia, a group of the Protozoa. The oval bodies are spores from which sporocysts arise by fission. The latter burst and their contents, the spores, are set free and penetrate neighbouring cells, which are thereby excited to proliferate. On the other hand degeneration phenomena may be observed with sporocysts. The author considers there is an ætiological connection between these forms and the development of sarcoma.

\* La Riforma Med., 1893, No. 154. See Centralbl. f. Bakteriol. u. Parasitenk., xiv. (1893) p. 812.

† Virchow's Archiv, cxxxiii. (1893) No. 1. See Centralbl. f. Bakteriol. u. Parasitenk., xiv. (1893) p. 810.





## BOTANY.

A. GENERAL, including the Anatomy and Physiology  
of the Phanerogamia.

## a. Anatomy.

## (1) Cell-structure and Protoplasm.

Cell-structure.\*—Dr. A. Zimmermann gives a very complete and valuable *resumé* of recent observations on the structure of the vegetable cell and of vegetable protoplasm.

In reference to the mode of cell-formation, he alludes to the remarkable observations of Mme. Weber-van-Bosse on the formation of spores in a thick peripheral layer within the tubes of *Phytophysa Treubii*, which he considers to correspond very closely with the formation of cells in the higher plants.

With regard to the consistency of protoplasm, the evidence is altogether in favour of its being more fluid than solid, though it is locally denser, especially at its bounding-surfaces, both towards the cell-wall and towards the cell-sap.

On the subject of the finer structure of the protoplasm, the author discusses the three principal theories, the filament-theory (including Fayod's theory of spirospiral and spirofibrillæ), the honeycomb theory, and the granular theory, and gives the arguments for and against each of these views. The spiral theory he has not been able to confirm by his own observations; he considers it most probable that vegetable protoplasts always have a granular structure. The position of the chromatophores within the protoplasts is affected by external factors; and it is probable also that the position of other substances enclosed within the cytoplasm is due to other causes than structural differences.

Under the head of the chemical composition of the protoplast, the existence of nuclein and nucleic acid is discussed, as is Loew and Bokorny's theory of the aldehyd nature of living protoplasm. A full account is given of the various instances in which protoplasmic connections from cell to cell have been detected, and of the views with regard to their function. The composition and finer structure of the resting nucleus are then treated of, with especial reference to (1) the chromatic (cyanophilous) constituents of the nucleus or nuclear framework, (2) the nucleolæ or erythrophilous constituents of the nucleus, (3) the nuclear membrane, (4) the nuclear sap, (5) protein-crystalloids. The next subjects are the centrosomes or attraction-spheres, all the various observations on these structures being referred to, and the division of the nucleus.

A separate section is then devoted to the special behaviour of the nucleus in the different groups of plants, viz. in the Algæ (including diatoms, Cyanophyceæ, bacteria, and Characeæ), Fungi (including Myxomycetes), Bryophytes, Pteridophytes, Gymnosperms, and Angiosperms.

Under each heading there is a copious citation of literature down to the year 1893.

\* Bot. Centralbl., 1893, Beih., pp. 206-17, 321-54, 401-36 (6 figs.).



**Internal Structure of the Cell-wall.\***—Herr C. Correns has investigated the inner structure of the cell-wall, chiefly in Algæ belonging to the Cladophoraceæ, Bryopsidæ, and Valoniaceæ. He does not find in these Algæ different systems of striation in the same lamella. Stratification depends on differences in the amount of water contained in the tissue; each lamella consists of two layers, a dense and a soft one. Striation is due, on the contrary, to a delicate folding of the lamellæ; each lamella is folded in one direction only, while the folds in two contiguous lamellæ are usually at right angles to one another. The readiness with which the lamellæ break up into fibres is due to their being differentiated, parallel to the folding, into striæ of different chemical and physical properties. The striation is the result of a process of growth, the innermost and youngest lamellæ appearing to be unstriated. The inter-crossing of the different systems shows that the folding cannot be due to external mechanical forces.

In the Characeæ the phenomena appear to be the same as in the classes of Algæ mentioned. In *Trentepohlia* there is a very peculiar structure of the cell-wall, the striation depending on cushion-like thickenings which arise centrifugally. In the Florideæ the striation depends, as in most Chlorophyceæ, simply on a folding of the membrane. In *Bornetia secundiflora* the cell-wall encloses masses of protoplasm, which form threads running within or on the surface of the denser lamellæ near to the septa.

Taking the whole vegetable kingdom, striation may be due to four causes, viz.:—(1) differences in the amount of water contained in smooth lamellæ (bast-fibres of Apocynaceæ, cuticle of the leaf of *Hyacinthus*); (2) a delicate folding of the denser lamellæ (cell-walls of Cladophoraceæ, Valoniaceæ, &c.); (3) a delicate centripetal thickening of the wall (tracheids of Coniferæ, hairs of *Cereus*); (4) a delicate centrifugal thickening of the wall (*Trentepohlia*, hairs of *Urtica*, and those on the filaments of *Narthecium ossifragum*).

**Crystallization of Cellulose and Chemical Structure of the Cell-wall.†**—M. E. Gilson has succeeded in crystallizing cellulose within the vegetable cell, by dissolving in cupric ammonium oxide and precipitating by ammonia. The aggregates of crystals are spherocrystalline or dendritic according to the concentration of the ammonia, and are rendered more visible by staining with chlor-zinc-iodide or congo-red. They exhibit all the characteristic reactions of cellulose. The authors obtained them from all membranes which are coloured blue by chlor-zinc-iodide, and from no other. They were procured also from the cellulose of Tunicates, but not from the cell-wall of Fungi. The reserve-cellulose appears to be a mixture of true cellulose and other carbohydrates.

The author distinguishes three distinct lamellæ in cell-walls, the middle lamella common to contiguous cells, an intermediate, and an inner lamella. Since the crystals are always formed in the interior of the cell, he concludes that the innermost lamella is always rich in cellulose; the intermediate lamella consists of cellulose and other substances,

\* Beitr. z. Morph. u. Phys. d. Pflanzenzelle (Zimmermann), i. (1893) pp. 260-305 (2 pls. and 1 fig.).

† La Cellule, ix. (1893) pp. 397-441 (1 pl.).

such as suberin, lignin, paragalactan, &c.; the middle lamella never contains cellulose.

The crystals always yield dextrose as the result of hydrolysis; and there is therefore only one kind of cellulose. The so-called mannose-cellulose obtained from coffee-seeds is a mixture of true cellulose and a new carbohydrate with the formula  $C_{12}H_{22}O_{11}$ , which he calls "paramannan." Cellulose appears to occur in different physical modifications, distinguishable by their solubility in alkalis. Under the term "hemicelluloses" Gilson includes all the carbohydrates present in the cell-wall which are not coloured blue by chlor-zinc-iodide, such as pectineous substances, reserve-cellulose, paragalactan, paramannan, &c.

**Chemistry of the Cell-wall.\***—Herr E. Schulze gives a detailed account of the chemical differences between true celluloses and hemicelluloses. The latter are distinguished by being readily soluble in hot dilute mineral acids, with formation of glucoses. On hydrolysis they form galactose, arabinose, xylose, &c., never true dextrose. The author finds these substances in the seeds of Leguminosæ (*Lupinus luteus*, *Soja hispida*, *Pisum sativum*, *Vicia Faba*), and in the bran of wheat and rye. They are also soluble in organic acids and in dilute alkalis, and are readily oxidized. True cellulose is readily transformed into grape-sugar by hydrolysis, mannose being, in some cases, produced in addition; galactose is never produced. It is probably therefore a polymerous anhydride of grape-sugar, or occasionally of mannose. Mannose-cellulose presents otherwise all the properties of ordinary cellulose, and has the same composition.

**Formation of Folds in Cell-walls.†**—Herr L. Kny discusses the so-called folds in the cell-walls of the antherids of *Chara*, and in the epidermal cells of the petals and the branched palisade-cells of the leaves of certain plants. As the result of measurements at different periods of their growth, he concludes that, with the single exception of the palisade-cells in the leaves of *Pinus austriaca*, the folding is only apparent. The deepest spots of the folds are the places where there has been the least superficial growth, on each side of which the membrane has protruded outwards in a sharp curve. In the branched palisade-cells of *Pinus austriaca*, there has been, on the other hand, an active growth of new cell-wall.

**Transverse Lamellation of the Membrane of Bast-cells.‡**—Herr C. Correns has investigated this structure, chiefly in the case of species of Apocynaceæ. He finds that the transverse lamellation depends on the formation of strongly refractive lamellæ, which cross the stratification nearly at right angles, sometimes anastomosing, but not forming a true network. Either all or only a few of the layers in a cell-wall may show this transverse lamellation. In the outer layers the lamellation may occur together with striation. The light-coloured transverse lamellæ are always very thin. They have become infiltrated by an unknown substance which is not albuminoid.

\* Zeitschr. f. phys. Chemie, xvi. (1892) pp. 387-438. See Bot. Centralbl., lv. (1893) p. 157. † Ber. Deutsch. Bot. Gesell., xi. (1893) pp. 377-91 (2 figs.).

‡ Tom. cit., pp. 410-25 (1 pl. and 2 figs.). Cf. this Journal, 1892, p. 56.

## (2) Other Cell-contents (including Secretions).

**Structure of Starch-grains.\***—As the result of very careful observations Dr. O. Bütschli concludes that the lamination of starch-grains is connected with a honeycomb-like structure. The regular formation of the layers is especially well seen in slightly swollen grains of arrow-root starch. Each layer has a distinct radial striation, and the striation of any one layer does not correspond in direction with that of the layers on each side of it. The honeycomb structure was even more distinctly seen in artificial starch-grains. The phenomena above described appear to agree rather with the theory of growth by apposition than with that of intussusception.

**Composition of Vegetable Albuminoids.†**—M. E. Fleurent has analysed some of the more important albuminoids found in plants—gluten, gluten-caseine, gluten-fibrine, legumine, and albumine—and finds that they have a somewhat different constitution from that determined for animal albuminoids by Schützenberger. The crude fixed residue of gluten and caseine contain carbon and hydrogen nearly in the proportion  $C_8H_{2n}$ . In the former the percentages are C 49·70, H 8·87; in the latter C 48·55, H 8·20.

**Accumulation of Carbohydrates in Leaves.‡**—Experiments made by Herr W. Saposchnikoff on vine-leaves show that where the atmosphere contains a more than normal amount of carbon dioxide, the limit of the accumulation of carbohydrates is more quickly reached.

**Inulin and its Allies.§**—According to M. C. Tanret, the inulin extracted from *Inula Helenium* and *Helianthus tuberosus* is not pure inulin, but is accompanied by two other allied substances, which he calls “pseudo-inulin” and “inulenin.” The mode of separating these substances is described. Pure inulin is very soluble in warm, but only very slightly soluble in cold water; moderately soluble in dilute alcohol. Both pseudo-inulin and inulenin are much more soluble than inulin in cold water.

**Distribution of Oxalic Acid in Plants.||**—Herr R. Giessler finds (in *Rumex*, *Oxalis*, and *Begonia*) that the oxalic acid is chiefly localized in the epiderm, or at least in the superficial tissues, where it is of the greatest use in protecting the plant against the attacks of animals. There is no oxalic acid, or but very little, in the underground organs. By far the largest quantity is found in the epidermal tissues of the leaves; in the stem it occurs chiefly in the cortical parenchyme. The function of oxalic acid is the same as that of tannins, and there is a close correspondence also in its local distribution. The amount of calcium oxalate in a plant generally increases with its age.

\* Verhandl. Natur.-Hist. Ver. Heidelberg, v. (1893) pp. 89–102. See Bot. Centralbl., lvi. (1893) p. 150.

† Comptes Rendus, cxvii. (1893) pp. 790–3.

‡ Ber. Deutsch. Bot. Gesell., xi. (1893) pp. 391–3. Cf. this Journal, 1891, p. 370.

§ Comptes Rendus, cxvi. (1893) pp. 514–7.

|| Jena'sch. Zeitschr. f. Naturwiss., xxvii. (1893) pp. 344–78. See Bot. Centralbl., lvi. (1893) p. 35.



Localization of the Active Principles in the Capparideæ, Tropæoleæ, Limnantheæ, and Resedaceæ.\*—M. L. Guignard finds myrosin to be widely distributed in all these natural orders.

In the Capparideæ (*Capparis*, *Cleome*, *Polanisia*, *Gynandropsis*) special ferment-cells containing myrosin are general in the root and stem; their morphological characters resemble those of the Cruciferae. They are most abundant in *Capparis*, as is also the glucoside which they decompose; they occur especially in the flower and in the pulp of the fruit. In all Capparideæ the seed contains but a small quantity either of the ferment or of the glucoside, and the ferment is localized in the embryo.

In the Tropæoleæ (*Tropæolum*) and Limnantheæ (*Limnanthes Douglasii*) all the organs contain myrosin; but the essence (a nitrile) does not exist in any of the tissues, and can be formed only by the action of the ferment.

In the Resedaceæ (*Reseda odorata* and *lutea*) the author finds myrosin to be present not only in the aerial organs, but also, in opposition to the observation of Spatzier,† in the root; in the stem it occurs in the cortical and liber-cells, as well as in the guard-cells of the stomates. Its presence in the root can be proved by macerating in water, leaving the mixture exposed to the air for some hours at a temperature of about 50° C., and evaporating. If the residue is then treated with water to which potassium myronate is added, a strong odour of essence of mustard is given off, demonstrating the decomposition of the glucoside by myrosin. That the essence of mustard does not occur as such in the root can be proved by treating with boiling absolute alcohol, which would dissolve out the essence if it were present.

### (3) Structure of Tissues.

Influence of Lignification on the Life of the Cell.‡—Herr O. Warburg refers to the cases in which it has been shown that cells the walls of which have become lignified, are still in a vital condition, and capable of segmentation, and discusses the question whether a production of meristem can take place from such cells. In opposition to the statement of some previous observers, he asserts that this is not the case. The new formations which take place in the woody tissue of climbing plants always proceed from the unligified cells, which are intercalated among the lignified. Thin-walled tissue can be formed from the lignified cells of medullary rays only when the protoplasts have lost their lignified coating as the result of gummosis.

Characteristics of Duramen.§—Prof. R. Hartig has carefully examined the differences in the structure of different parts of the trunk of the oak (*Quercus pedunculata*), some of the trees being as much as 400 years old. The formation of the annual ring begins about April 20th, and is completed in the lower part of the trunk by the middle of August, in the upper portion by the beginning of September. The

\* Journ. de Bot. (Morot), vii. (1893) pp. 345-64, 377-82, 393-400, 444-60 (18 figs.), and Comptes Rendus, cxvii. (1893) pp. 493-6, 587-90, 751-3, 861-3. Cf. this Journal, 1891, p. 362. † Cf. this Journal, ante, p. 76.

‡ Ber. Deutsch. Bot. Gesell., xi. (1893) pp. 425-41 (3 figs.).

§ S.B. Bot. Ver. München, Nov. 13, 1893. See Bot. Centrabl., lvi. (1893) p. 357.



formation of duramen begins about the middle of July. It is distinguished from the alburnum by the absence of starch, by the presence of thyllæ, by an increase of substance of about 6 per cent., and by an increase in the specific gravity of the substance of which the cell-wall is composed from 1.55 to 1.59; the proportion of carbon has increased by about 1 per cent. The various tissues of the oak contain different tannins. The brown colour of the duramen is due to subsequent changes.

**Comparison of Duramen and Alburnum.\***—From a series of experiments on the composition of the ash, Herr H. Zimmermann finds that the alburnum of trunks (chiefly elm) usually contains no lime, while large quantities of calcium carbonate are often stored up in the duramen. The largest quantity was found in the innermost rings of wood.

**Internal Pericycle.†**—According to M. L. Flot the vascular portion of the inner pericycle does not originate on the inner margin of the procambium. On the inner side of the vascular bundle a larger or smaller portion of the procambium is retained, and this the author proposes to call the *internal pericycle*. It forms a continuous zone when the bundles are connected laterally; while it is composed of distinct bands when they are free. Various kinds of tissue are regarded by the author as products of the inner pericycle:—long-celled parenchyme in the Cruciferae, Papaveraceae, and Euphorbiaceae; lignified elements in many trees, also in some Compositae and Umbelliferae; sieve-tube elements in the Apocynaceae, Asclepiadaceae, Solanaceae, Enothereae, &c.; a meristem, from which either sieve-tube or vascular bundles may subsequently be formed; the bundle-sheath of Monocotyledons; and a band of elongated cells uniting the bundles, in *Achyranthes*, *Fagopyrum*, *Begonia*, Labiateae, &c.

**Mucilage of the Membrane of Vegetative Organs.‡**—Herr H. Walliczek has investigated the structure and origin of the mucilaginous epiderm of leaves, and classifies the various instances under three types, viz.:—(1) the lowermost wall of the epidermal cells is simply thickened by a secondary mucilaginous membrane; (2) a layer of cellulose is subsequently deposited upon this mucilage (this has been misinterpreted as an epiderm composed of two layers of cells); (3) the upper and lower wall of certain epidermal cells are both thickened by a secondary mucilaginous membrane, on which is deposited a layer of cellulose, the lateral wall remaining unthickened; (4) an alternate deposition of mucilage and cellulose takes place on the wall of nearly all the epidermal cells. The mucilage is always formed as such, and is not the result of the transformation of other substances.

In a large number of trees and shrubs, of which *Tilia grandifolia* may be taken as a type, mucilage cells occur in the interior of all the vegetative organs, the thickening-layers of which are subsequently for the greater part absorbed. The mucilage is never formed, as has been stated by some writers, within the protoplasts, but always on the boundary between the primary cell-wall and the protoplasm. Within

\* Zeitschr. f. angewandte Chemie, 1893, pp. 426–30. See Bot. Centrallbl., lvi. (1893) p. 37.

† Comptes Rendus, cxvi. (1893) pp. 332–4.

‡ Jahrb. f. wiss. Bot. (Pringsheim), xxv. (1893) pp. 209–77 (3 pls.).

the pith the development of the mucilage is completed about the period of blossoming, and it may then take as much as five years to become completely absorbed. After its first formation it becomes gradually differentiated into layers.

As regards its function, the accumulation of mucilage is to be regarded neither as an excretory product nor as a reserve food-material, but probably as a contrivance for the storing up of water.

**Secondary Wood of the Apetalæ.\***—By the use of histological characters derived from the structure of the wood, M. C. Houlbert classifies the natural orders belonging to the Apetalæ into eight families, having but little genetic affinity to one another. Of these eight families, five, viz. the Urticaceæ, Piperaceæ, Polygonaceæ, Chenopodiaceæ, and Proteaceæ, have a superior, the remaining three, viz. the Cupuliferæ, Santalaceæ, and Aristolochiaceæ, an inferior ovary. The special features presented by transverse, radial, and tangential sections are described in the case of a large number of genera and species. The Proteaceæ are divided into three sections, the *Banksia*, the *Orites*, and the *Protea* groups. Nearly related to the Proteaceæ are the Elæagnaceæ, Myricaceæ, and Casuarineæ; while the Thymeleaceæ are much more remote. With the Piperaceæ may be associated the Chloranthaceæ and Garryaceæ. The Chenopodiaceæ are divided into two groups, the Amarantheæ and Chenopodieæ, with the Phytolaccaceæ, Batideæ, and Nyctagineæ as allies. The Myristicaceæ show strong affinities to the Polygonaceæ. The Urticaceæ are divided into two groups, the Urticoideæ and Ulmoideæ. The Salicineæ are nearly allied to the Cupuliferæ through the Betulaceæ. The Cupuliferæ themselves may be divided into two groups, the Betuloideæ and Castaneoideæ. The Juglandæ are allied to the Cupuliferæ, while the true position of the Platanaceæ is much more obscure.

As a *resumé*, the general plan of structure of the wood is usually uniform within a family. The woody parenchyme diminishes as the number of vessels increases, and *vice versâ*; and the thicker the woody fibre the broader are the medullary rays, and *vice versâ*.

**Seedlings of Coniferæ.†**—Following Van Tieghem's classification,‡ M. P. A. Dangeard divides Conifers firstly into those with inverted and those with erect ovules, and the former again into four sub-tribes, viz. (1) Pineæ, with one pericyclic secreting canal in front of each vascular bundle; (2) Cedreæ, with an axile secreting canal; (3) Araucarieæ, with several pericyclic secreting canals in front of each bundle, the secreting canals of the leaves being cortical; (4) Podocarpeæ, resembling the Araucarieæ, but the secreting canals of the leaves peridesmic. In the Pineæ and Cedreæ the ovary has two ovules, in the Araucarieæ and Podocarpeæ only one. In all Conifers with inverted ovules the root has secreting canals in its primary structure; those with erect ovules include the Cupresseæ and Taxeæ. Detailed description of the anatomical structure of the seedling is given in the case of a number of species belonging to the genera *Pinus*, *Picea*, *Larix*, *Tsuga*, *Araucaria*, *Cupressus*, *Actinostrobus*, *Thuja*, and *Taxus*.

\* Ann. Sci. Nat. (Bot.), xvii. (1893) pp. 1-183 (8 pls.).

† Le Botaniste, iii. (1893) pp. 126-204 (6 pls.). Cf. this Journal, 1890, p. 479.

‡ Cf. this Journal, 1892, p. 61.

Among the more general results obtained are that in *Pinus* there is a continuity between the secreting canals of the leaf and those of the cortex of the stem; each foliar bundle, when it enters the stem, is accompanied by two secreting canals. Secreting tubes are very widely distributed in seedling Conifers, and consist of intercellular spaces, usually situated below the epiderm in the pericycle and the pith. The foliar bundle is frequently accompanied by a vascular wing, composed of transfusion tissue, which attains its greatest development in the Cupressæ. This forms an independent circulating system, after the foliar bundle itself has lost its function of carrying sap from the root. The augmentation in the number of cotyledons in many Gymnosperms appears to result from the division of two large cotyledons, which have broken up into a number of equivalent structures.

**Root of Arborescent Liliaceæ.\***—M. H. J. de Cordemoy describes a remarkable development of metaxylem in the root of *Lomatophyllum borbonicum*, *Dracæna marginata*, and *Cohnia flabelliformis*. The large vessels of metaxylem, proceeding from the differentiation of conjunctive cells of the central cylinder, develop not only on the internal margin of the phloem-bundles, but also on that of the protoxylem-bundles, which they prolong towards the centre of the root, and also in the medullary parenchyme properly so called. These vascular bundles disturb in a remarkable way the symmetry of the central cylinder of the root.

In the root of *Dracæna marginata* the secondary formations originate, not from the pericycle, but from the cortex. There is in these cases a centrifugal increase in the size of the central cylinder, causing a rupture of the endodermal ring, and bringing the pericycle into contact with the secondary cortex. A communication is thus established between the primary and secondary conducting systems, i. e. between the central cylinder and the cortical zone.

**Anatomy of Combretaceæ.**—Herr H. Heiden † gives a full account of the structure of the various organs in this natural order, followed by descriptions of all the genera and of a number of the species. Among the more noteworthy characters are the usually bicollateral structure of the vascular bundles; the vessels with bordered pits even in the walls in contact with the medullary rays; the absence of mucilaginous epidermal cells; the wood-parenchyme with simple pits; the absence of special auxiliary cells to the stomates; and the invariable presence of simple unbranched and unicellular but two-chambered hairs.

Herr C. Holtermann ‡ also describes the structure of a number of genera and species of Combretaceæ, but finds very few general characters which distinguish them from the allied orders.

**Anatomy of Afromendoncia and Mendoncia.§**—According to Herr E. Gilg, the splitting of the xylem in these genera of Acanthaceæ is due to the formation of wedges of leptome. The medullary cambium is

\* Bull. Soc. Bot. France, xl. (1893) pp. 42-6, 145-7.

† Bot. Centralbl., lv. (1893) pp. 353-60, 385-91; lvi. (1893) pp. 1-12, 65-75, 129-36, 163-70, 193-200, 225-30 (1 pl.).

‡ 'Beitr. z. Anat. d. Combretaceæ,' 47 pp., Bonn, 1893. See Bot. Centralbl., lvi. (1893) p. 305.

§ Ber. Deutsch. Bot. Gesell., xl. (1893) pp. 351-64 (1 pl.).



formed, not from the cells which have passed over into a resting condition, but either from the meristem of the growing point or from the cambium of these leptome wedges.

#### (4) Structure of Organs.

**Female Catkins in Populus.\***—Mr. T. Meehan records an instance of a young tree of *Populus tremuloides* in which some of the catkins consisted entirely of female flowers, while in others about one-third of the scales bore stamens only, and about two-thirds pistils only.

**Opening of the Buds of Woody Plants.†**—Mr. A. S. Hitchcock describes and delineates the mode in which a number of native American trees and shrubs unfold their leaves.

**Vernation in the Compositæ, Campanulaceæ, and Lobeliaceæ.‡**—Herr F. Reinecke has examined the mode in which the leaves are folded up in the bud in a large number of species of Compositæ belonging to different tribes, and finds no general characteristics in this respect for the different groups. In the Campanulaceæ the mode of vernation is much more constant.

**Spiny Plants.§**—M. A. Lothelier discusses the morphological nature of the spines in various plants, classifying them under three heads, viz.—(1) branch-spines; (2) leaf-spines; (3) spurs (*aiguillons*), by which he understands a spine not containing any vascular bundle. There are also various intermediate conditions between the typical forms. The spines of *Xanthoxylon* and of *Capparis spinosa* are spurs; those of *Xanthium spinosum* are peduncles conerescent with stipules; those of the cupule of *Castanea vulgaris*, and of the fruit of *Datura*, *Æsculus Hippocastanum*, *Ricinus communis*, and *Caucalis daucoides*, have the morphological value of leaf-teeth. The author finds the formation of spines to be largely dependent on the external conditions of the individual. The saturation of the air with moisture, and the diminution of light, have a tendency to reduce the differentiation of tissues, and consequently the production of spines. Under these conditions the number of stomates is also reduced.

**Comparative Anatomy of Leaves.||**—According to M. C. de Candolle vascular bundles occur in the pith of the leaf-stalk and veins of a large number of Dicotyledons. In most Rosaceæ the xylem-elements are wanting towards the upper side of the leaf.

**Leaves of Irideæ.¶**—Dr. H. Ross completes his account of the leaves of Irideæ by the description of those belonging to a large number of different genera. The leaves are completely bifacial and dorsiventral only in the genera *Crocus* and *Syringodea*, in the section Juno of *Iris*, and in *Romulea crocifolia*; in all other cases examined the surface of the lamina corresponds morphologically to the under surface

\* Proc. Acad. Nat. Sci. Philadelphia, 1893, p. 289.

† Trans. Acad. Sci. St. Louis, vi. (1893) pp. 133-41 (4 pls.).

‡ 'Ueb. d. Knospenlage d. Laubblätter b. d. Compositen u.s.w.,' 63 pp. and 1 pl., Breslau, 1893. See Bot. Centralbl., lvi. (1893) p. 100.

§ Rev. Gén. de Bot. (Bonnier), v. (1893) pp. 48<sup>o</sup>-3, 518-28 (8 pls.).

¶ Ber. Schweiz. Bot. Gesell., 1892, pp. 35-6. See Bot. Centralbl., lvi. (1893) p. 372. ¶ Malpighia, vii. (1893) pp. 345-90. Cf. this Journal, 1893, p. 500.



of bifacial leaves. In some species the mechanico-conducting bundles are provided with mechanical elements on their outer side. Calcium oxalate is generally diffused through the leaves, but never in the form of raphides, except in the genera *Tecophilæa* and *Campynema*, which should probably be excluded from the order.

**Anatomy of the Leaves of Sapotaceæ.\***—Herr G. Holle describes the structure of the epidermal cells, hypoderm, trichomes, stomates, vascular bundles, bundles of sclerenchyme, and laticiferous vessels, in the Sapotaceæ. The family is characterized by the presence of two-armed unicellular hairs. The mesophyll is invariably permeated by laticiferous vessels which contain caoutchouc. The palisade-tissue, and sometimes also the spongy parenchyme, likewise contain particles of caoutchouc.

**Venation of Cycas.†**—The venation of the leaves of *Cycas* and *Stangeria* differs from that of other Cycadeæ; and M. O. Lignier finds these two genera to agree more nearly with one another than has generally been supposed. In *Cycas revoluta* and *circinalis* a number of very fine vascular bundles run from the midrib to the margin of the leaflet, resembling the arrangement in *Stangeria*. The venation of these two genera approaches that of ferns, and is noteworthy from a phylogenetic point of view.

**Laticiferous Hairs of the Cichoriaceæ.‡**—Herr L. Kny states that hairs containing latex are widely distributed through the Cichoriaceæ, and describes them in detail in the case of *Lactuca Scariola*. They form papillæ on the involucre, and are in connection with the laticiferous system of the rest of the plant through a narrow canal at their base.

**Anatomy of Vellosiaceæ.§**—Prof. E. Warming describes the anatomical structure of this South American natural order (twenty-three species of *Vellosia*, eight of *Barbacenia*). The texture and structure of the leaves are adapted to their universal xerophilous habit. In *Vellosia* the stem is clothed with a covering of roots which form a complete mantle round it. They do not break through the leaf-sheaths, but penetrate between them outside the bark, whence the author terms them "inter-vaginal" roots.

**Root-tubers.||**—Herr M. Drohnig describes the structure of the root-tubers in a large number of species of Dicotyledons and some of Monocotyledons. In *Ficaria ranunculoides*, *Tradescantia crassifolia*, and *Echeandia* their formation depends on an excessive development of the cortical parenchyme, no pericambial cork being formed, and in some cases not even a phellogen. In *Œnanthe* and *Aconitum* their origin is from a secondary growth of the central cylinder of the root. In *Oxalis*,

\* 'Ueb. d. anatom. Bau d. Blattes in d. Sapotaceen u.s.w.,' 59 pp. and 1 pl., München, 1892. See Bot. Centralbl., lvi. (1893) p. 334.

† Bull. Soc. Linn. Normandie, 1893, 7 pp. See Bot. Centralbl., lvi. (1893) p. 151.  
‡ SB. Gesell. Naturf. Freunde Berlin, July 18, 1893. See Bot. Centralbl., lvi. (1893) p. 392.

§ Overs. K. Danske Vidensk. Selsk. Forhandl., 1893, 44 pp. and 15 figs. See Bot. Centralbl., lvi. (1893) p. 94.

|| 'Beitr. z. Kenntn. d. Wurzel-knollen,' 80 pp., Breslau, 1892. See Bot. Centralbl., lvi. (1893) p. 89.

*Dahlia*, *Cirsium*, and *Pæonia*, the secondary growth produces a secondary meristem, chiefly on the xylem side; the new masses of tissue are not usually lignified. The development of the secondary epidermal tissue varies greatly. In *Oxalis* there is no formation of cork. In *Dahlia* the phellogen is formed from the primary cortex. The primary epidermal tissue may pass into the permanent condition by suberization of the epiderm and exoderm; or the tuber is protected outwardly by formation of periderm. The formation of cork may be accompanied or not by a throwing off of phelloderm. The phellogen originates either in the primary cortex or in the pericambium.

The structure of the conducting tissue varies according as it is intended for the transport of water or of plastic substances; the number of vessels is always small. The strengthening elements, bast-fibres, and libriform are also greatly reduced. The reserve-system is distinguished by a great development of active parenchyme. Calcium oxalate and tannins are excreted abundantly.

### B. Physiology.

#### (1) Reproduction and Embryology.

**Embryology of Flowering Plants.\***—Dr. M. Westermaier has investigated the processes which take place in the embryo-sac after fertilization—chiefly in certain Ranunculaceæ and Gramineæ—especially in relation to the function of the antipodals. In *Nigella* (*sativa* and *damascena*), the antipodals come finally to occupy a lateral position in the embryo-sac, nearer to its micropylar than to its chalazal end, owing to the unilateral growth of the sac. The same is the case in many Gramineæ. The swollen appearance of the antipodals, and the mode of distribution of the starch in these cases, indicate that antipodals are not mere functionless survivals, but play an important function in the formation of the endosperm-cells and in the conveyance of nutrient materials to the growing embryo. In other cases (*Zea Mays*, *Salvia pratensis*, and many other Dicotyledons and Monocotyledons), the part played by the antipodals appears to be less important; though here also it is not without significance; they occupy the chalazal extremity of the embryo-sac, and must be regarded as the portion first formed of the endosperm-tissue.

**Embryology of Gnetum.†**—Pursuing his investigations on this subject, Herr G. Karsten describes in detail the development of the male, of the imperfect female, and of the perfect female flowers. The first division of the pollen-mother-cells originates from a contraction of the chromatin framework of the nucleus. The imperfect female flowers form a terminal whorl in the male inflorescence. About twenty free parietal nuclei are formed in the embryo-sac. When these disappear, a drop of fluid exudes from the micropyle, which probably served, in the first place, to detain the pollen-grains carried by the wind, while it now performs the function of a nectary. This temporary embryo-sac attains

\* Nova Acta Acad. Cæs. Leopold-Carol., lvii. (1892) pp. 1-39 (3 pls.). Cf. this Journal, 1891, p. 766.

† Beitr. z. Biol. d. Pflanzen (Cohn), vi. (1893) pp. 337-82 (4 pls.). Cf. this Journal, 1892, p. 506.

its fullest development in *G. Gnemon*; in *G. Rumphianum* it could not be detected.

In the perfect female flowers there are always at first numerous embryo-sacs. In *G. verrucosum* sp. n., *ovalifolium* sp. n., and *Rumphianum*, these are finally reduced to one; in *G. Gnemon* and *funiculare* there are often still two or three at the period of fertilization, all capable of impregnation. While the pollen-grains are still within the anther they contain three nuclei, one of which becomes subsequently absorbed. Within the pollen-tube the generative nucleus (in *G. funiculare*) divides, as in Coniferæ, though it is doubtful whether two distinct generative cells are formed. The two generative nuclei appear to enter the embryo-sac, and to coalesce with one of its nuclei. The staining reactions of the sexual nuclei do not correspond with the observations of Rosen and Schottländer. The author's previous statements with regard to the changes which take place in the generative nucleus before impregnation must be modified. After impregnation, either the primary germ-nuclei divide, become enclosed in the endosperm, and develop into long tubular embryos, or they become enclosed in one of the endosperm-cells, and produce, by division, the secondary true embryo-cells which subsequently develop into pro-embryos.

Herr Karsten establishes six species of *Gnetum*, two of them new.

**Embryology of *Veronica hederæfolia*.**\*—According to Dr. L. Buscalioni the ovule of this plant is of the monochlamydeous type, consisting of a very small nucellus, and of an integument formed from the epiderm of the ovular tubercle. The hypodermal cell of the ovular tubercle divides into four cells, one only of which develops, and becomes the embryo-sac. The endosperm is formed only in the central part of the embryo-sac, the two ends growing into appendages which the author calls the chalazal and the micropylar arms. The originally anatropous ovule thus assumes a somewhat campylotropous appearance. The raphe has no xylem-vessels nor sieve-tubes. The endosperm divides into a central and a peripheral portion, the cells of the latter being in protoplasmic communication with one another. A little before the seed is ripe, a cushion of endosperm is formed round it, which brings the two arms together on the concave side of the seed, and gives it a shell-like form. The suspensor forces itself into the micropylar arm of the embryo-sac, and consists of a long row of cells full of starch. It serves to supply food-material to the ovule, and, at a later period, becomes entirely absorbed. The epiderm, and partially also the subjacent layers of the integument of the ovule, become converted before maturity into a spongy mass, the innermost layer alone forming the testa of the ripe seed. The membranes of both ends of the embryo-sac, and those of the cells of the chalazal branch of the endosperm, increase in thickness by the apposition of granules of cellulose produced from the microsomes of the protoplasm.

**Cross-Pollination and Self-Pollination.**—Mr. C. Robertson † describes the adaptation of the flower for cross-pollination in a number of

\* Mem. R. Accad. Sci. Torino, xliii. (1893) pp. 477-522 (2 pls.).

† Trans. Acad. Sci. St. Louis, vi. (1893) pp. 101-31. Cf. this Journal, 1893, p. 503.



American species of Labiatae. By far the larger number are specially adapted for the visits of bees.

In another paper \* Mr. Robertson contributes notes on the mode of pollination and the insect visitors of *Stellaria media*, *Malva rotundifolia*, *Sida spinosa*, *Abutilon Avicennæ*, *Hibiscus lasiocarpus*, *H. Trionum*, *Geranium carolinianum*, *Oxalis violacea*, and *Melilotus alba*.

Mr. J. McLeod † explains the contrivances for pollination in nearly 400 species, natives of Belgium.

Mr. T. Meehan ‡ records a number of further observations. In *Malva rotundifolia* the flowers are never visited by insects and are abundantly fertile. Pollination generally takes place within the unopened bud. The flowers of *Brunella (Prunella) vulgaris* are visited by a small species of humble-bee; but it apparently takes no part in the pollination of the stigma, which seems to take place before opening. In *Lythrum Salicaria* cross-pollination appears sometimes to take place without the aid of insects. In *Bidens bipinnata* and *Heliopsis lævis* the stigmas are apparently self-pollinated, as in most Composite. *Scutellaria galericulata* also appears to be self-pollinated; it is difficult for insects to reach either the anthers or the stigmas. In *Trifolium pratense* the author has observed humble-bees to enter the mouth of the corolla, and not to perforate its tube.

**Cross-Fertilization of Cereals.**§—Mr. W. Carruthers epitomizes the results which have been obtained from experiments in crossing the various varieties of cereals. Self-fertilization is shown to be the rule in wheat, by the simultaneous ripening of the stamens and stigma, and the partial discharge of the pollen on the stigma before the flower opens. Barley is completely self-pollinated in the bud. Of the seven types of cultivated wheat, the author regards five, *Triticum Spelta*, *dicoccum*, *vulgare*, *turgidum*, and *durum*, as forms of one species of which *T. Spelta* is probably the nearest living representative of the original form; *T. monococcum* is certainly, and *T. polonicum* probably, a distinct species. All the cultivated forms of barley appear to belong to one species; and the same is probably the case with the oat.

**Pollination of Yucca.**||—Mr. W. Trelease describes all the American species of *Yucca*, with their contrivances for pollination. *Pronuba Yuccasella* is the chief agent in the pollination of several species. *Y. Whipplei*, belonging to the subgenus *Hesperoyucca*, has the pollen agglutinated into coherent masses. It is ordinarily pollinated by *P. maculata*; but, when not visited by this moth, can self-pollinate.

**Red Colour of the Perianth.**¶—Prof. A. Hansgirg discusses the biological meaning of the blood-red colour of the club-shaped appendage to the inflorescence of *Arum maculatum*, of the flowers of *Cynoglossum officinale* and *Sanguisorba officinalis*, and of the central flower of the

\* Bot. Gazette, xviii. (1893) pp. 267-74.

† Bot. Jaarb. (Gheut), 1893, pp. 156-462 (many figs.). See Bot. Centralbl., lvi. (1893) p. 177.

‡ Proc. Acad. Nat. Sci. Philadelphia, 1893, pp. 294-6, 297-9, 301-6, 308-9.

§ Journ. R. Agric. Soc. England, iv., 19 pp. and 7 figs.

|| Ann. Rep. Missouri Bot. Garden, iv. (1893) pp. 181-226 (19 pls.). See Bot. Centralbl., 1893, Beih., p. 498. Cf. this Journal, 1893, p. 209.

¶ Bot. Centralbl., lvi. (1893) pp. 262-3.



inflorescence of *Daucus Carota*, &c. It is usually associated with a peculiar odour, and is connected with the attraction of certain insects which are useful for the pollination of the species, and the repulsion of others.

(2) Nutrition and Growth (including Germination, and Movements of Fluids).

**Influence of Light on the Propagation of Plants.\***—Dr. G. Klebs discusses this subject in detail, especially in reference to the non-sexual propagation of the lower plants.

In some Algæ, as *Chlorococcum infusionum* and *Ulothrix zonata*, light has very little or no influence on the formation of the swarmspores, acting only through the stimulus to nutrition. In *Vaucheria* and *Hydrodictyon reticulatum* the favourable effect of light on the production of swarmspores is much more evident; in the latter case especially the influence of light is apparently direct.

In those Mosses in which the product of germination of the spore is an alloid filiform protoneme—e. g. *Funaria hygrometrica*—the formation of buds on the protoneme is essentially dependent on light; if light is excluded, the protoneme continues to grow without producing buds, a phenomenon which the author compares to the production of *Chantransia* from *Batrachospermum* in the dark. When, however, a protoneme is developed from a cut leaf of *Funaria*, it forms buds in the dark much more readily than does a protoneme resulting from a spore. The substances required for the formation of the bud are probably already present in the leaf. The germination of the spores of the Hepaticæ is also dependent on light, as is likewise the production of the sexual organs on the prothallium of ferns.

In sexual reproduction the processes are much more complicated. In the majority of Algæ light is an important factor in the production of sexual organs. This is remarkably the case with the formation of these organs in *Vaucheria* and *Cedogonium*, with the process of conjugation in *Spirogyra*, *Closterium*, and *Cosmarium*, and with the production of the female organs in the Hepaticæ and Musci.

As respects Flowering Plants the statements of different observers with regard to the influence of light on growth appear at first sight to be at variance with one another. According to the researches of Sachs,† the leaves contain all the substances necessary for the formation of flowers, which can, therefore, be developed in the dark. The ultraviolet rays are especially effective in the production of the sexual organs; and with algæ the blue-violet half of the spectrum is much more efficient for this purpose than the red-yellow half. Parasites destitute of chlorophyll can develop flowers in perfect darkness.

**Influence of Light on Flowers.‡**—Dr. H. Vöchting discusses the influence of light on the form and position of flowers. Experiments on the growth of a great variety of species under different degrees of illumination showed that a minimum of illumination is essential for the

\* Biol. Centralbl., xiii. (1893) pp. 641-56. † Cf. this Journal, 1892, p. 510.

‡ Jahrb. f. wiss. Bot. (Pringsheim), xxv. (1893) pp. 149-208 (3 pls.) Cf. this Journal, 1887, p. 266.

development of normal flowers, but that this minimum varies greatly according to the species. On this point plants may be roughly divided into the two classes of sun- and shade-plants. If the illumination falls below the minimum for the species, either the size of the whole flower or of its parts is greatly diminished, or the formation of flowers is completely suspended. The corolla is the part first affected. The attracting organs are superfluous when the visits of insects cease, as is the case with a low illumination, and the flower becomes dependent on self-fertilization.

Many species have only one kind of flower, which varies in structure according to the external conditions, being open and capable of cross-pollination when the conditions are favourable, closed and self-pollinated when the conditions are unfavourable. In other species two kinds of flower are produced, differing only slightly from one another, one open and chasmogamous, the other closed and cleistogamous. This leads to those cases where the plant possesses cleistogamous flowers of very different structure from the chasmogamous; and further to those in which cleistogamous flowers only are produced.

In the formation of zygomorphic flowers, recent observations show that light has a decided influence, in addition to gravitation; the upper lip becomes gradually reduced as the result of diminished illumination, or even disappears altogether, as in some Labiatae. Natural selection appears to play only a secondary part, assisting the direct action of external physiological factors.

Diminished illumination has the further effect of hindering or even entirely suppressing the production of flowers in flowering plants.

**Rhythmic Growth.\***—Mr. T. Meehan gives illustrations of rhythmic or interrupted, in contrast to continuous growth, in the case of the fruit of a number of species of *Citrus*, especially in the Tangerine orange and in a variety known as the "navel orange," in which there is an attempt to form another fruit at the apex, usually accompanied by a failure to produce seeds. Further instances are afforded by the prolific growth of the flower frequent in many Rosaceae, and in the development of the inflorescence of two species of Compositae, *Heliopsis laevis* and *Bidens bipinnata*.

**Physiological Function of Anthocyan.†**—By experiments with an alcoholic solution of leaves of *Beta vulgaris* var. *rubra* and var. *Rapa*, Herr L. Kny has determined that anthocyan has the property of hindering the decomposition of chlorophyll by light. Further experiments also showed that it has, in some cases, the power of converting the luminous rays of the sun into heat, and that the elevation of temperature in leaves containing anthocyan is less behind a blue than behind an orange fluid, and less behind the latter than behind a colourless fluid.

**Influence of Mechanical Traction on Growth.‡**—From experiments made by Herr R. Hegler, chiefly on *Cannabis sativa*, *Dahlia variabilis*, *Phaseolus multiflorus*, *Helianthus annuus*, and *Tropaeolum majus*,

\* Proc. Acad. Nat. Sci. Philadelphia, 1893, pp. 292-4, 303-6.

† Atti Congr. Bot. Internat., 1892 (9 pp.). See Bot. Centralbl., lvi. (1893) p. 272.

‡ Beitr. z. Biol. d. Pflanzen (Cohn), vi. (1893) pp. 383-432 (4 pls.).

he concludes that the retardation of growth caused by mechanical traction on a growing organ is a typical phenomenon of irritation. It is not the result of a decrease of hydrostatic pressure in the cells of the organ submitted to traction.

(3) Irritability.

**Movements of Flowers and Leaves.\***—Prof. A. Hansgirg adduces further illustrations of the following phenomena:—Periodic opening and closing of flowers; ephemeral flowers; pseudo-cleistogamic flowers; sensitive stamens; nyctitropic movements and paraheliotropic curvatures of leaves; positively heliotropic curvatures of flower-stalks; carpotropic curvatures belonging to the seven different types; periodic curvatures of flower-stalks; and nodding of inflorescences.

**Movements of the Flowers of Veronica.†**—Herr J. af Klercker has observed by means of a camera lucida the movements during flowering of those species of *Veronica* in which the flowers are arranged in spikes or racemes. He classifies the species examined under four types; of the first *V. longifolia* may be taken as a good example.

In this species the axis of the inflorescence and the flower-stalks are always brought, before the flowers open, into a definite position with respect to the horizon; and, if disturbed from this position, again return to it. This movement ceases after the flowers open. After the opening of the flower the style assumes successively three different positions. In the first there is a geotropic curvature downwards, the maximum of which coincides with the period of maximum growth. In the second movement the style again raises itself to a horizontal position; while in the third it again curves downwards, but does not regain this position if reversed. This movement is attributed by the author to positive geotropism.

The three other types do not differ essentially from the first, but in the fourth, of which *V. virginica* is an example, the first geotropic downward curvature of the style does not take place.

The author propounds the theory that the power of growth of any definite zone of an organ is constant. When, therefore, one side of an organ increases in length by geotropism, the other side must subsequently grow more rapidly, and the geotropic curvature must be neutralized.

**Movements of the Flower-stalk of Cobæa.‡**—The late Dr. M. Scholtz described the changes in position of the flower-stalk of *Cobæa scandens* before and after flowering. During the development of the bud it is negatively geotropic and positively heliotropic. Its end bends in a horizontal direction, and the calyx opens. The upper side of the stalk then grows more rapidly than the under side, and gives the flower a pendent position. The flowers are strongly proterandrous, and the two upper stamens, which stand in the front of the flower, open before the others. Their filaments then curve inwards, and the other three stamens take

\* Bot. Centralbl., lvi. (1893) pp. 257-62. Cf. this Journal, 1893, p. 69.

† Bih. K. Svensk. Vet.-Acad.-Handl., xviii. (1893) Afd. 3, 29 pp. and 31 figs. (German).

‡ Beitr. z. Biol. d. Pflanzen (Cohn), vi. (1893) pp. 305-36 (2 pls. and 10 figs.).



their place. It is only after their filaments have curved back in the same way that the style increases in length, and brings the stigma, now ready for pollination, into the same position that the anthers previously occupied. At the time when the first anthers open the corolla is green, with a disagreeable odour; after the last have opened it becomes dark purple, with a strong odour of honey. After pollination, which is probably effected by insects, geotropic movements again take place in the flower-stalk, which bring the fruit into a pendent position. The flower-stalk of *Cobæa* affords an instance of an organ with complicated anisotropy. Its anatomical structure is dorsiventral.

(4) Chemical Changes (including Respiration and Fermentation).

**Transformations of Reserve-substances during Germination.\***—

M. E. Mesnard has investigated this subject in the case of oily seeds and those of grasses, and states the following general conclusions:— Except in the case of grasses, the fatty oils are not localized in special layers, but are found in cells belonging to the various tissues of the endosperm or of the cotyledons. Like the albuminoids, they disappear gradually as needed for the formation of fresh tissues. The oil is always formed independently of starch or glucose. The author disputes the hypothesis of the doubling of the oils by saponification under the influence of a special diastase; the presence of fatty acids may be explained by the oxidation of the oils or of the albuminoids which always accompany them. It is probable that certain reserve-substances always exist from the first in the same cells as the oils.

**Germination of Ricinus.†**—M. Leclerc du Sablon finds that, in the germination of the castor-oil plant, the amount of oil in the endosperm diminishes with the growth of the radicle, falling from about 67 to about 10 per cent. of the dry weight. The proportion of fatty acid (ricinic acid) increases irregularly as germination proceeds. The quantity of glucose in the resting seed is very small; during germination it increases rapidly, being formed more or less directly by the transformation of starch. After reaching a maximum it again decreases, being converted into starch and other substances.

**Production of Saccharose in the Germination of Barley.‡**—In the artificial germination of barley M. L. Lindet finds a progressive increase in the amount of saccharose, which is produced at the expense of starch.

**Function of Citric Acid in Assimilation.§**—Herr C. Wehmer believes that the sphaerocrystals and raphides, which have hitherto been considered to consist invariably of calcium oxalate, are frequently composed rather of calcium citrate. Their chemical reactions agree with this hypothesis. He suggests also that the carbonic acid set free in respiration need not always be the result of the breaking up of molecules of albumen, but may also be derived from the splitting up of acids rich in oxygen.

\* Bull. Soc. Bot. France, xl. (1893) pp. 35-42.

† Comptes Rendus, cxvii. (1893) pp. 524-7. ‡ Tom. cit., pp. 668-70.

§ Ber. Deutsch. Bot. Gesell., xl. (1893) pp. 333-43 (10 figs.).



## γ. General.

**Effects of Fog on Plants.\***—Prof. F. W. Oliver records the results of a large number of observations on the effects of urban fog on cultivated plants. The foliage is affected chiefly by the decrease of light, which causes a withdrawal of starch from the chlorophyll-corpules; by the action of acids, especially sulphurous; and by the action of organic substances contained in the sooty deposit, chiefly phenol and some form of pyridine. In addition to its directly poisonous effect, sulphurous acid acts by diminishing transpiration. With flowers the period of expansion appears to be an especially sensitive time. The effects on them of fogs may be referred to plasmolysis, loss of colour, a yellowing due to oil, and a browning, caused by a fine precipitate in the protoplasm. Monocotyledons suffer from fog less than Dicotyledons, and Ferns much less still.

**Insectivorous Habit of *Dionæa*.†**—From observation of *Dionæa muscipula* in its native habitat, Mr. B. Dean states that the position of the trap is more adapted for the capture of creeping than of winged insects. A far larger quantity of the remains of the former were found in the traps than of the latter, the escape of larger winged insects being also facilitated by the slowness with which the trap acts. The leaves frequently close on vegetable and even on inorganic objects when captured. After digestion has taken place, the position of the trap, when re-opened, allows the undigested particles to fall to the ground. The sensitiveness is not confined to the bristles, but belongs in a modified degree to the whole of the upper surface of the leaf.

**Perfume of the Violet.‡**—MM. F. Tiemann and P. Krüger have analysed the perfume which occurs both in the flower of the violet and in the rhizome of *Iris*, and find it to be a cetone with the formula  $C_{13}H_{20}O$ , to which they give the name *irone*. The mode of extraction of irone, and its chemical properties and compounds, are described.

## B. CRYPTOGAMIA.

## Muscineæ.

**New Genera of Musci.**—In a collection of Mosses from Japan M. E. Bescherelle § describes a number of new species, and the following new genera:—

*Fauriella* (Leskeæ). Plantæ tenellæ, repentes et adscendentes, fragiles, molles, glaucovirides, ramis erectis, ramulis patentibus plumosis; folia ovata, cymbiformia, ecostata, subtus papillosa, serrata v. obsolete dentata, areolatione rhomboidea; capsula minuta, erecta, post sporosim cernua et horizontalis, operculo conico, apiculato; peristomii dentes colorati, dense trabeculati, siccitate incurvi, interni membrana brevi perfecti, siccitate erecti; cilia breviora, terna in uno coalita; calyptra cucullata, elongata, contorquata, lævis.

\* Journ. R. Hort. Soc., xvi. (1893), 59 pp.

† Trans. New York Acad. Sci., xii. (1893) pp. 9-17.

‡ Comptes Rendus, cxvii. (1893) pp. 548-52, and Atti R. Accad. Lincei, ii. (1893) pp. 350-4.

§ Ann. Sci. Nat. (Bot.), xvii. (1893) pp. 327-93.

*Myuroclada* (Brachythecieae). Caulis illecebrinus, ramis turgide julaceis, simplicibus, fasciculatis, interdum arcuatis, ramulosis; folia dense imbricata, vernicosa, cochleari-concava, rotunda v. ovata, acuminata, areolatione subrhomboidea, semi-costata; capsula in pedicello unciali laevi inclinata, ovato-cylindrica v. cernua; operculo conico, longe rostrato; peristomium hypnoideum, magnum; dentes interni valde hiantes.

Under the name *Struckia*, Dr. K. Müller\* separates from *Hypnum* the species *argentatum*, and forms it, together with three new species, into a genus with the following diagnosis;—Folia e basi plus minus constricta, latiuscule ovata, in acumen longissimum cuspidata; theca in pedunculo longissimo glabro erecta, ovalis, microstoma; annulus latus; peristomium simplex; dentes externi 16, breves, lineari-lanceolati, parce trabeculati; calyptra dimidiata, caulis plumosus.

Structure of *Buxbaumia*.†—Prof. F. O. Bower criticizes Goebel's explanation of the peculiarities in the structure of *Buxbaumia*, and argues that they may be largely the result of reduction rather than an indication of the survival of an archaic structure. Prof. Bower further contests Goebel's statement ‡ that it can be experimentally proved that the sporophylls of leptosporangiate ferns are modified leaves.

Relations of Nucleus to Spore-formation in Liverworts.§—Prof. J. B. Farmer reminds us that, as a general rule, during the formation of spore-tetrads from their mother-cells, the nucleus of the latter undergoes two successive bipartitions. Each of the resulting four nuclei ultimately becomes a centre for the aggregation of a portion of the original protoplasm. The deviations he has observed are probably modifications of this method.

After briefly describing what may be seen in *Aneura multifida* and *A. pinguis*, the author remarks that the most conclusive and striking results were obtained with *Steetzia decipiens*, which he collected in Ceylon. The nucleus is invested by a dense mass of protoplasm (archoplasm), and this, as in *A. pinguis*, forms a quadripolar achromatic spindle, while the nucleus is still in the resting condition. The ends of the spindle severally reach out to a point beyond the centre of each lobe. Though he calls the spindle achromatic, following the common usage, the author found that it stains deeply with hæmatoxylin, saffranin, or gentian-violet; the chromatic portion of the nucleus forms a large mass in the centre, and becomes four-lobed, the lobes being united centrally till quite late. When they separate each breaks into two chromosomes of a rod-like shape, and they speedily arrange themselves in pairs; each pair furnishes the chromatic element to the daughter-nucleus. The cell walls rapidly meet in the centre, and their union is effected before the reconstruction of the daughter-nuclei. The spindle mass contracts up to the middle of each of the four cells, and invests the young nucleus in the same manner as was the case with the original body.

\* Rev. Bryol., xx. (1893) pp. 94-5.

† Ann. Bot., vii. (1893) pp. 367-80. Cf. this Journal, 1893, p. 216.

‡ Cf. this Journal, 1888, p. 261.

§ Proc. Roy. Soc. Lond., liv. (1893) pp. 478-80.

## Algæ.

**New Genera of Algæ.\***—Dr. H. Klebahn describes two new genera of Algæ, viz. :—

*Dicoleon*.—Filamenta articulata, ramosa, in muco valde evoluto sub-hemisphærico vegetantia et quasi thallum disciformem formantia, ramis repentibus pluricellularibus prædita; cellulæ arcte in filamenta concretæ et præterea utriculis brevissimis arctis conjunctæ, partim in dorso setigeræ; setæ longissimæ, vaginis duabus, altera longa tubuliformi, altera quæ est externa brevissima, in inferiore parte circumdatæ. *Dicoleon Nordstedtia*, mixed with *Aphanochæte globosa* f. *major*.

*Conochæte*.—Cellulæ in filamenta non conjunctæ, in muco valde evoluto subgloboso v. subhemisphærico vegetantes; cellulæ filiæ post divisionem membranis cellulæ matris extensis inclusæ, sed mox muco separatæ; membranæ in setas plures longissimas caducas, vagina conica gelatinosa in basi præditas, productæ. *C. polytricha* (*Aphanochæte polytricha* Nordst.), and *C. comosa* sp. n. This genus belongs to the Palmellaceæ.

He further gives a new diagnosis of *Aphanochæte* (which generic name he considers must stand, to the exclusion of Hansgirg's *Herposteiron*), and of *Chætosphæridium*, from which *Nordstedtia* Borz. is quite distinct.

Prof. A. Hansgirg † criticizes various points in this paper; and Dr. Klebahn ‡ rejoins.

**Polymorphism of Trentepohlia.§**—Herr K. Deckenbach claims to have proved by cultivation the identity of *Trentepohlia lagenifera*, *aurea*, and *umbrina*, which he unites into one species with the name *T. polymorpha*. *T. umbrina* was taken in winter and cultivated. At first some of the cells became sporanges with red zoospores. The cells then began to divide and to develop into filaments, the red pigment becoming at the same time transformed into chlorophyll. Some of the cells assumed a red colour, and developed into pear-shaped zoosporanges, and the plant was typical *T. aurea*. In the beginning of the summer the whole plant again became green, formed flask-shaped sporanges, and was then *T. lagenifera*. In July the colour became a deep orange; the terminal cells of some of the branches became thick-walled and hemispherical, an ovate sporange being finally abstricted from the apex. The plant is transformed into *Chroolepus uncinatum*.

## Fungi.

**Composition of the Cell-wall of Fungi.**—From observations made on fungi belonging to a large number of different classes :—Peronosporaceæ, Saprolegniaceæ, Mucorini, Uredineæ, Ustilagineæ, Basidiomycetes, Ascomycetes—M. L. Mangin || observes that the terms fungine, metacellulose, and fungus-cellulose are misleading, as implying the existence of a single substance in all fungi, which is not the case.

\* Jahrb. f. wiss. Bot. (Pringsheim), xxv. (1893) pp. 278-321. Cf. this Journal, 1893, p. 361. † Bot. Centralbl., lvi. (1893) p. 31. ‡ Tom. cit., p. 323.

§ Script. Bot., 1893, 16 pp. and 1 pl. See Bot. Centralbl., lvi. (1893) p. 77.

|| Comptes Rendus, cxvii. (1893) pp. 816-8. ,



Cellulose is most commonly altogether wanting, and when present displays different properties from those which it ordinarily possesses; it is insoluble in Schweizer's reagent, and is inert towards iodine reagents. The fundamental substance of the mycelium is usually callose; and this furnishes a very valuable character for detecting the presence of fungus-parasites. In *Agaricus campestris*, *Boletus purpureus*, and *Cantharellus cibarius*, the callose is replaced by substances apparently of a pectic nature.

From experiments on various fungi (*Boletus edulis*, *Polyporus officinalis*, *Agaricus campestris*) Herr E. Winterstein\* confirms the ordinary view that the substance of which the cell-wall is composed differs in its chemical properties from ordinary cellulose.

Herr I. Dreyfuss† states, on the contrary, that he has found true cellulose in *Polyporus*, *Agaricus campestris*, and *Aspergillus glaucus*, also in *Bacillus subtilis* and in pus bacilli.

**Malformations produced by *Cystopus candidus* and *Røstelia cancellata*.**—Sig. V. Peglion‡ has studied the hypertrophy of the tissues of *Raphanus Raphanistrum* caused by the attacks of *Cystopus candidus*, especially in the axis of the inflorescence and in the ovary. The epidermal cells of the axis are greatly lengthened in the tangential and transverse directions, causing the fissure of the stomates to stand nearly at right angles to the axis. The cortical parenchyme consists of very large cells with only small intercellular spaces. At the spots where the parasite develops its fructification large accumulations of starch are formed, which are used up in the formation of the conidia. The distribution of the vascular bundles is affected, which is the case also in the seed-vessels.

The same author§ describes the tumours produced in the leaves and branches of the pear by the attacks of *Røstelia cancellata*.

**Parasitic Fungi.**—Herr A. Nilsson|| describes the ravages committed on the pine-forests of Scandinavia by the attacks of *Peridermium Pini*, *Agaricus melleus*, and *Hypoderma sulcigenum*. The relationships of the various species of *Peridermium* to their *Cronartium* form are discussed.

M. A. de Janczewski¶ describes a new parasitic fungus, *Scolecotrichum Boudieri*, found on *Reseda odorata*.

M. E. Mer\*\* gives details of the injury inflicted on *Abies excelsa* by the attacks of *Phoma abietina* (*Fusicoccum abietinum*).

M. P. Hariot†† identifies *Æcidium carneum* and *Uromyces carneus*, parasitic on *Phaca astragalina*, with *Æ. Hippocrepidis* and *Æ. Astragali*.

Prof. B. D. Halsted‡‡ describes, under the name *Exobasidium Peckii*, a new species parasitic on *Andromeda Mariana*, which causes the flowers

\* Ber. Deutsch. Bot. Gesell., xi. (1893) pp. 441-5.

† Zeitschr. f. phys. Chemie, xviii. pp. 358-79. See Journ. Chem. Soc., 1894, Abstr., ii. p. 24.

‡ Riv. di Patologia Vegetale, i. (1893) pp. 265-84. See Bot. Centralbl., lvi. (1893) p. 312.

§ Op. cit., ii. (1893) pp. 23-37. See Bot. Centralbl., lvi. (1893) p. 339.

|| Tidskr. Skosk., xii. (1893) pp. 38-71. See Bot. Centralbl., lvi. (1893) p. 184.

¶ Bull. Soc. Mycol. France, 1893. See Bull. Soc. Bot. France, xl. (1893) Rev. Bibl., p. 151.

\*\* Journ. de Bot. (Morot), vii. (1893) pp. 364-75. †† Tom. cit., pp. 375-6.

‡‡ Bull. Torrey Bot. Club, xx. (1893) pp. 437-40 (1 fig.).



to assume an erect position, and the corolla to be deeply divided. The other American species of the genus are enumerated, all, with one exception, parasitic on Ericaceæ.

A disease of the apricot-tree which is causing great destruction of the crop in parts of Germany, was found by Herr R. Aderhold\* to be always accompanied by a great development of *Cladosporium herbarum*, and especially by the form of that fungus known as *Dematium pullulans*, together with a species of *Hendersonia*; but whether the former is the cause of the disease he was unable to determine. The latter is certainly not parasitic.

Fungus-parasite of *Sphagnum*.†—M. S. Nawaschin describes the parasitic fungus the spores of which have been described as "microspores" of species of *Sphagnum*. He gives it the provisional name *Tilletia Sphagni*.

Fungi which produce Citric Acid.‡—Herr C. Wehmer has found, in carrying on experiments on the production of oxalic acid by fungi, a genus, to which he gives the name *Citromyces*, which has the remarkable power of converting carbohydrates into citric acid. Of the genus he describes two species, *C. Pfefferianus* and *glaber*. Their ordinary mode of multiplication is by conids; but they occasionally produce other structures, which may be sclerotes or asci; and a yeast-like budding also occurs. The production of citric acid is in the first place due to oxidation of the carbohydrate, and is dependent on the presence of oxygen. The most favourable nutrient substratum for its formation is a moderately concentrated solution of sugar. To both species the parasitic fungus *Penicillium luteum* is very destructive.

Spores of Yeast.§—Herr M. Moeller records fresh experiments which disprove the statement of Krasser,|| that no true nucleus is to be found in yeast-cells. In the mature spores he always finds, by the use of the proper reagent—a preparation of hæmatoxylin—a membrane and nucleus, as also in the vegetative cells. His observations throw no certain light on the systematic position of the Saccharomycetes.

Fermenting Grape- and Apple-must with Pure-bred Yeasts.¶—The fermentation experiments made by Herren E. Mach and K. Portele with *S. cerevisiæ*, *S. Pastorianus* i. and iii., *S. ellipsoideus* i. and ii., *S. apiculatus*, and *Monilia candida*, on grape- and apple-must, show that the quantity of alcohol and glycerin produced depend directly on the ferment. Thus, for 100 parts by weight of alcohol, 6.42 parts of glycerin were formed by *S. apiculatus*, 3.88 by *Monilia candida*, and 4.68 by *S. cerevisiæ*. The last-named yeast produced 11.82 volumes of alcohol in the same time that 2.9 volumes were produced by *S. apicu-*

\* Landwirthsch. Jahrb., xxii. (1893) pp. 435-67 (1 pl.). See Bot. Centralbl., lvi. (1893) p. 153.

† Bull. Acad. Imp. Sci. St. Petersburg, xiii., pp. 349-58. See Bot. Centralbl., 1893, Beih., p. 526. Cf. this Journal, 1891, p. 73.

‡ Comptes Rendus, cxvii. (1893) pp. 332-3; and Beitr. z. Kenntn. einheimischer Pilze; see Bot. Ztg., lii. (1894), 2<sup>te</sup> Abtheil., p. 6.

§ Ber. Deutsch. Bot. Gesell., xi. (1893) pp. 403-9 (1 pl.).

|| Cf. this Journal, 1893, p. 366.

¶ Landwirthsch. Versuchs-stationen, xli. (1892) pp. 233 and 261. See Bot. Centralbl., lv. (1893) pp. 57-8.

*latus*; and this latter ferment was found to evolve no inconsiderable quantity of volatile acids, e. g. 40 times as much as *S. Pastorianus*, when inoculated on wine-must.

When inoculated on apple-must, only feeble fermentation was excited by all the organisms, and this was attributed by the authors to the small quantity of nitrogen in the medium; for when tartrate of ammonia was added fermentation became significantly greater.

The authors regard *S. apiculatus* as a weed among the yeasts, the development of which should be suppressed, and express the opinion that pure-bred yeasts should be used not only for grape, but for apple fermentation.

The attention of these authors was also turned to the question of the time when fermentation is most active; and it would seem that the first part of the process is marked by proliferation of the yeast, and that the production of alcohol becomes greater in the course of the process.

**Effront's Process for Purification and Preservation of Yeast.\***—MM. A. Jörgensen and J. Ch. Holm have tested the value of Effront's process for the purification of yeast by means of hydrofluoric acid and the fluorides, and show, from a series of thirty-nine experiments, that this method is associated with great danger, and becomes in practice quite useless. Of their experiments the following are examples:—If a distillery yeast be mixed with a very small quantity of *Mycoderma* and *Bact. acetii*, and then treated by Effront's method, it will be found that these organisms have multiplied extraordinarily. If a pure cultivation of a specially selected distillery yeast be mixed with 20 per cent. of top or bottom yeast and then treated by the fluoride method, the growth of the distillery yeast is quite suppressed by that of the top or bottom yeast. If *S. Pastorianus* iii. be mixed in very small quantity with a bottom brewery yeast or a distillery yeast, and then treated by Effront's method, the disease-yeast will be found to have multiplied excessively and may actually exterminate the cultivation yeast.

**New Form of Propagation in Mycoderma.†**—Prof. B. Fischer describes a new form of propagation which he has observed in three species of *Mycoderma*. The observations were made from hanging drop cultivations in beer-wort and beer-wort gelatin. The cells described are distinguished by a certain brilliancy and a bluish shimmer. Under high powers there can be seen in their interior a small spheroidal body which attains a diameter of about 2  $\mu$ . This body, which at first is scarcely distinguishable from a single endogenous spore, soon alters its position, betaking itself to the periphery, either at one of the poles or at the equator, and passes through the wall of the mother-cell, close to which it remains. When free it gradually attains adult proportions, and at the same time its brightness diminishes. The whole process takes about one hour and it may be repeated in the same mother-cells as often as three consecutive times.

**Acetic Acid-forming Blastomycete.‡**—Dr. F. Lafar describes the physiological characters of a blastomycete discovered in beer which had

\* *Moniteur scientifique* du Dr. Quesneville, vii. (1893). See *Centrabl. f. Bakteriologie u. Parasitenk.*, xiii. (1893) pp. 566-8.

† *Centrabl. f. Bakteriologie u. Parasitenk.*, xiv. (1893) pp. 653-6.

‡ *Tom. cit.*, pp. 684-96 (2 figs. and 1 pl.).

undergone acetic fermentation. Hence the usually received opinion, viz. that *Mycoderma aceti* is the one and only cause of acetic fermentation, appears likely to be upset, and it is probable that this function will be found to be shared by other organisms. The new blastomycete was cultivated in sterilized beer, and in 92.5 cm. of fluid 1.098 grm. of acetic acid were produced, or 1.19 per cent.

The morphology and the classification are promised later, the author's preliminary communication being concerned only with two points, viz. that Turpin had no share in the discovery of the acetic acid bacteria, and the merit thereof is to be ascribed to Kützing alone; and that the contention of Pasteur, who maintained in the 'Études sur le Vinaigre' that *Mycoderma vini* could split up alcohol directly into carbonic acid and water without an intervening formation of acetic acid, can no longer be upheld.

**Fungus which forms several Different Lichens.\***—Herr A. Möller has found in Brazil a fungus belonging to the Thelephoreæ which has the remarkable property of entering into the composition of three different lichens belonging to the genera *Cora*, *Dictyonema*, and *Laudatea*, of Hymenolichenes. The fungus was found associated with *Cora*, which grows abundantly on the ground; and a connection was determined between the hyphæ of the two. The gonids of *Cora* belong to *Chroococcus*, while those of *Dictyonema* and *Laudatea* are *Scytonemata*. These two algal genera were proved to be identical, the latter being the form assumed when creeping on the substratum, the former when rising erect on the branches of trees. The fungus-element is in both the same species of *Thelephora*. The passage of the hyphæ from one lichen-form to the other was observed in several cases. The advantage gained by the fungus from its symbiosis was shown by the fact that when it grows on the summits of lofty trees or on small trees on the high mountains, it is never without its nutritive symbiont.

**Alternation of Generations in the Uredineæ.†**—Herr F. v. Tavel points out that, while in some cases each generation of heterœcious Uredineæ is confined to a particular family or even genus of host-plants, e. g. *Gymnosporangium*, this is not usually the case. Especially in regard to the æcidio-generation, which is mostly found on a host-plant growing in a similar situation to that attacked by the uredospore-generation, rather than on one genetically allied to it. A number of examples of this law are given; also a few exceptions, such as the occurrence of *Coleosporium Tussilaginis* on *Tussilago farfara*, which has no connection, either in affinity or habit, with Conifers.

**Suckers of the Uredineæ.‡**—According to M. Sappin-Trouffy the Uredineæ possess suckers as well developed as those of the Peronosporæ and Ustilagineæ. They are described in detail in the case of *Puccinia graminis*, *Uromyces Betæ*, and *Coleosporium Senecionis*. They result from a slight swelling, which may assume various forms, of a cell of the mycele; the swollen part is entirely enclosed in a cell of the host-plant,

\* Flora, lxxvii. (1893) pp. 254-78.

† Ber. Schweiz. Bot. Gesell., 1893, pp. 97-101. See Bot. Ztg., li. (1893), 2te Abtheil., p. 297.

‡ Le Botaniste (Dangeard), iii. (1893) pp. 215-9 (1 pl.).



its pedicel perforating the wall of the cell. They ultimately attack and deform the nucleus of the host-cell.

**Pseudo-fecundation in the Uredineæ.\***—M. Sappin-Trouffy describes the three stages of this process in the case of *Gymnosporangium Sabinæ*, viz. the formation of the teleutospore, the fusion of the nuclei, and the germination of the spore. The teleutospore is formed on a hymenial layer differing perceptibly from the subjacent hymenial stroma, and each cell of this layer may produce two or three spores. All the cells of the hymene are bi-nucleated; the nuclei of those which are to produce teleutospores are especially large, and contain nucleoles; the two nuclei of the spore may eventually be separated by a septum or not. The process of pseudo-fecundation consists in the fusion of these nuclei. The teleutospore has four pores, whether it be unicellular or bicellular. The promycete resulting from the germination of the teleutospore consists of four cells, each with a single nucleus. Each of these cells gives birth to a slender tube, which swells up at the apex to form a conid.

**Fertilization of the Puccinieæ.†**—M. P. Vuillemin describes the process of the formation of the æcidiospores in *Peridermium Pini* (the æcidio-form of *Coleosporium Senecionis*) termed by Dangeard pseudo-fecundation, which he regards as a true process of fertilization, the æcidiospore being the generator of a new plant. The two nuclei of the fertile cell which conjugate are gametes identical in their origin and in their morphological value. The process may be compared to the fusion, in the embryo-sac of Angiosperms, of the two nuclei, the result of whose union is the formation of the thallus known as the endosperm. The previous separation of an abortive cell is analogous physiologically to the throwing off of a polar cell.

**Puccinias Parasitic on Compositæ.‡**—Herr P. Magnus describes in detail the various forms of *Puccinia* belonging to the type *P. Hieracii*, parasitic on different species of Composite. They belong to four sections, viz. :—(1) Auteupuccinia; these develop spermogones, æcidia, stylospores, and teleutospores on the host; (2) Brachypuccinia; develop spermogones, stylospores and teleutospores in the first generation; from the stylospores small masses are formed, which again develop stylospores and teleutospores; (3) Pucciniopsis; only spermogones and æcidia are produced in the first generation, only teleutospores in the second; (4) Micropuccinia; only teleutospores are produced, and only one generation in a year; the teleutospores fall off readily, and germinate in the next spring. Forms of the second and fourth types occur, especially at high altitudes, where the period of vegetation is short.

**Puccinia Paridis and interstitialis.**—Dr. C. B. Plowright and Mr. W. Thomson § have established the genetic connection between the rare æcidium found on *Paris quadrifolia* and a *Puccinia* parasitic on *Phalaris arundinacea*. Four other species of *Puccinia* are already known to be parasitic on this grass, viz. *P. sessilis*, *Phalaridis*, *Digraphidis*, and *coronata*. The æcidia of these species occur on four different

\* Le Botaniste (Dangeard), iii. (1893) pp. 205-8. Cf. this Journal, 1893, p. 666.

† Comptes Rendus, cxvi. (1893) pp. 1461-7.

‡ Ber. Deutsch. Bot. Gesell., xi. (1893) pp. 453-64 (1 pl.).

§ Journ. Linn. Soc. (Bot.), xxx. (1893) pp. 43-4.



host-plants, which are not interchangeable, viz. respectively on *Allium ursinum*, *Arum maculatum*, *Convallaria majalis*, and *Rhamnus Frangula*.

Herr W. Tranzschel\* identifies *Cœoma interstitiale*, parasitic on *Rubus saxatilis*, with *Puccinia Peckiana*, found on various species of *Rubus*, which must now be known as *P. interstitialis*.

*Achromatium oxaliferum*.† — Herr W. Schewiakoff describes an organism which he designates *Achromatium oxaliferum*. It was obtained from the mud of the Altrhein and appears to have a wide distribution. In shape it is elliptical to spherical, and occasionally exhibits slow intermitting movements, but no locomotive organs were observed. Some examples were imbedded in a gelatinous sheath. The membrane of *Achromatium* has a honeycombed structure and a proteid composition. Within the meshes of this honeycomb structure are peculiar highly refractive corpuscles which in the living organism render the central body quite invisible. From their chemical and optical reactions the author concluded that these corpuscles are composed of oxalate of lime, and considers that they are analogues of chromatin corpuscles. The fission stage of the organism is marked by a constriction about the centre; by the gradual deepening of this constriction the organism finally separates into two equal halves.

### Protophyta.

#### a. Schizophyceæ.

**Structure and Cell-division of Diatoms.**‡ — Herr R. Lauterborn has detected an actual perforation in the wall of a species of *Surirella*, at the spot where foreign bodies become attached and are driven rapidly backwards and forwards. The furrows of *Pinnularia* are chambers communicating with the interior of the cell, and in the living state, are filled with protoplasm. In the larger forms the protoplasm is often differentiated into strings. The so-called "red granules" of Bütschli (stained red by Delafield's hæmatoxylin) were detected in a number of diatoms, and in some desmids and Rhizopods. They are stained a deep-red violet by methyl-blue. Pyrenoids were observed only in a very few instances, forming elliptic or fusiform structures within the chromatophores. A single nucleus is present in all diatoms; in the resting condition it has a reticulate honeycomb-like framework. It is always nucleolated. In some large species a centrosome is seen near the nucleus; as long as the nucleus is in a resting state, there is never more than one. The mode of division of the nucleus is always karyokinetic, and the various stages of the process are described in detail.

**Spores of Diatoms.**—L'Abbé Comte Castracane§ gives a *resumé* of the evidence on which he has arrived at the conclusion that the most frequent mode of reproduction in diatoms is by a process of sporulation or production of germs. That the bodies which he regards as diatom-spores are not the spores or germs of parasites, he considers to be proved

\* Hedwigia, xxxii. (1893) pp. 257-9.

† Heidelbergger Habit.-Schr., 36 pp., 1 pl. See Bot. Centralbl., liv. (1893) pp. 264-5.

‡ Verhandl. Naturhist. Ver. Heidelberg, v. (1893) 26 pp., 1 pl. and 1 fig.

§ Le Diatomiste, ii. (1893) pp. 29-36, 41-9.

by the fact that he has detected in these bodies a very delicate siliceous coat.

Dr. P. Miquel,\* on the other hand, is unable to confirm the correctness of this statement in a very large number of cultures of diatoms, in which he has been able to follow out their life-history. The bodies within the cells of diatoms which have the appearance of spores, have, according to his experience, no power of germination.

**Nucleus of Diatoms.**†—Dr. P. Miquel asserts that cell-division in diatoms is invariably preceded by a division of the nucleus. The best reagent for observing this he finds to be methylene-blue in an aqueous solution, either pure or slightly boric, which stains the nucleus a light violet-blue, while the stipe is coloured only with difficulty, and other spherical corpuscles of a different nature contained within the valves assume a dark blue or almost black tint. The nucleus is often rendered exceedingly difficult of observation by the phæoleucites by which it is surrounded, or from its refrangibility being only slightly in excess of that of the surrounding protoplasm. Species specially favourable for its detection are *Coscinodiscus concinnus* and *Biddulphia aurita*. Dr. Miquel asserts that there is no intimate contact between the protoplasm and the enclosing siliceous valve. Whether the division of the nucleus takes place by karyokinesis or by simple fragmentation is still uncertain. It is only after the division of the nucleus has taken place that the cytoplasm divides into two nearly equal portions. The nucleus is always surrounded by a mass of circumnuclear protoplasm, which differs in its reactions from the rest of the cytoplasm.

**New Genera of Diatoms.**‡—Among a large number of new pelagic and fossil diatoms, Prof. J. Brun describes the following new genera:—

*Cotyledon*.—Valve more or less circular, with an elevated crest, and irregularly folded. Near to *Mastogonia* and *Stephanogonia*.

*Hydrosilicon*.—Valve lamellar (sometimes panduriform), bearing, both transversely and longitudinally, a pseudo-raphe with simple or double bifurcations towards the extreme curves of the valves; margin thick, ribbon-like, covered by a row of large pearls; the centres of the radiation of the striæ are the axes of crossing of the raphes.

*Radiopalma*.—Frustule pellicular, with more or less regular orbicular outline; ribs linear, running from the edges towards the centre, irregular in size and often dichotomous; surface punctated or striated.

**Schmidt's Atlas der Diatomaceen-Kunde.**—The most recently published part (Heft 47) of this splendidly illustrated work consists of 4 plates (185–8), almost entirely devoted to species of *Mastogloia*, with a few also belonging to *Orthonelis* and *Dictyonelis*. The author defines the genus *Mastogloia* as including those diatoms which have in the interior four free canals or double canals.

**Structure of the Cells of Phycchromaceæ.**—Herr G. Hieronymus § reaffirms his conclusions on several points respecting the structure of the cells of the Phycchromaceæ. The green pigment he believes to be connected with coloured granules or grana, while the blue pigment is

\* Tom. cit., pp. 26–9. † Ann. de Micrographie, v. (1893) pp. 437–61 (3 pls.).

‡ Mém. Soc. Phys. et Hist. Nat. Genève, xxxi. (1893) 48 pp. and 12 pls.

§ Bot. Ztg., li. (1893) 1<sup>re</sup> Abtheil., pp. 73–80. Cf. this Journal, 1890, p. 371.

dissolved in the cell-sap. The grana—granules or crystalloids of cyanophycin—are apparently only of one kind, presenting uniform chemical and physical characters.

Herr E. Zacharias,\* replying to the observations of Hieronymus, asserts that he has not, at present, been able to detect in the Cyanophyceæ chromatophores surrounded by protoplasm. The protoplasm with green punctations does not appear to be surrounded by a colourless layer of protoplasm specially differentiated and in contact with the cell-wall.

Prof. R. Chodat and Madame O. Malinesco † find, in the protoplasm of the Cyanophyceæ, only one kind of refringent corpuscle. These vary in number and size according to age and other circumstances; but they all exhibit the same chemical reactions, being stained by aluminated hæmatoxylin, vesuvin, nigrosin, saffranin (imperfectly), acetic methyl-green, and gentian-violet, and are then decolorized by alcohol. They are not the result of the breaking up of a central nucleus, they take no part in cell-division, they do not correspond to the chromatin of the nucleus of higher plants, and their identity with the corpuscles of Bütschli has not been established.

**Oscillatoriaceæ.**‡—Prof. A. Hansgirg criticizes Gomont's monograph of the Oscillatoriaceæ in several points, especially in that he has in some instances united under the same species forms which are essentially different, while in others he has separated forms which are but stages of development of the same species.

**Phormidium.**§—M. M. Gomont calls attention to the fact that in some species of *Phormidium* the thallus has a more or less complicated ramification, as e. g. in *P. tinctorium*, *fasciculatum*, and *uncinatum*. The plant which has been described as *Calothrix putida* is a branched variety of *P. Retzii*, and is identical with *P. fasciculatum*. Under the name *P. penicillatum* the author describes another new marine species from the island of Réunion, in which the thallus is also branched, the upper portion of the fascicles being cemented together by a firm gelatinous sheath.

### β. Schizomycetes.

**Action of Light on Bacteria.**||—Prof. H. Marshall Ward has published an abstract of his third memoir on this subject. He has succeeded in obtaining photographic records by throwing the spectrum on an agar film evenly charged with the spores and bacilli to be investigated, and has observed the behaviour of the illuminated regions after incubation. Broadly speaking, the action begins at the blue end of the green, rises to a maximum as we pass to the violet end of the blue, and diminishes as the ultra-violet regions are reached; the bactericidal effect, however, extends far into the ultra-violet.

The results suggest that the naked arc-light may prove to be a very efficient disinfecting agent in places where the rays can be projected

\* Bot. Ztg., li. (1893) 2<sup>o</sup> Abtheil., pp. 225-9.

† Arch. Sci. Phys. et Nat., xxix. (1893) pp. 108-10.

‡ Bot. Centralbl., lv. (1893) pp. 72-6. Cf. this Journal, 1893, p. 514.

§ Bull. Soc. Bot. France, xl. (1893) Sess. Extraord., pp. lxxxvi.-xc. (1 pl.).

|| Proc. Roy. Soc. Lond., liv. (1894) pp. 472-5 (2 figs.).



directly on the organism; and it is extremely desirable that experiments should be made on the action of light on living cells of animals, as the results obtained would probably be of importance as regards sun-burn, sun-baths, and other matters.

**Acetic Acid Bacteria.\***—Prof. E. C. Hansen finds that acetic acid bacteria occur under three chief forms—chains, filaments, and swollen forms. Cultivated on a suitable medium at 34° C. the vegetation consists of chains; if this be cultivated at 40 $\frac{1}{4}$ ° it is replaced by filaments. Under these conditions filaments 200  $\mu$  and more long are developed from individuals measuring only 2–3  $\mu$ . Transferred to 34° the long filaments are reduced to the chain form again. If the development from 34°–40 $\frac{1}{4}$ ° be followed step by step, it will be found that the organism, or rather its elements, increases not only in length but in thickness, and often to such a degree that striking swellings or dilata-tions are apparent. So different are the three forms, that they would be assuredly taken for three distinct species if observation had not proved them to have arisen one from the other.

**Gaseous Products of Bacteria.†**—The researches of Dr. W. Hesse on the gaseous metabolic products of bacteria, and especially on their relation to oxygen and carbonic acid, have led him to conclude that bacteria respire just like animals. For his experiments the author used Hempel's apparatus and the following organisms:—the bacilli of cholera, anthrax, typhoid, glanders, tubercle, and Pfeiffer's capsule bacillus, as well as the three anaerobes, symptomatic anthrax, tetanus, and malignant œdema. The results may be summed up very shortly. Bacteria take in oxygen and give off carbonic acid; the more freely they grow the more copiously they do so. Under exactly similar circumstances the interchange of gases will be exactly the same. Therefore the oxygen present in the cultivation vessel will be used up at a rate different for different organisms, and varying with difference in the environment, e.g. the medium, the temperature, &c. The quantity of the oxygen used up and that of the carbonic acid produced are therefore different for different bacteria and under different conditions of environment. This quantity can be measured. And if the quantity of oxygen lost or of carbonic acid gained can be practically estimated, this quantity might become a factor for differential diagnosis or for determining the age of a cultivation.

**Respiration-Figures of Mobile Bacteria.‡**—By respiration figures, Dr. M. W. Beyerinck means the arrangement assumed by mobile microbes under the influence of oxygen and nutritive media.

The figures were studied under two conditions, in test-tubes and as wedge-shaped layers between a slide and cover-glass. In the first case a test-tube is nearly filled with water, and a bean (*Phaseolus vulgaris* var. *nanus*) dropped in. In a day or two bacteria will be found forming a cloudy band across the tube at some distance between the bean and the water surface. This band is called the bacterial level. Levels

\* Ber. Deutsch. Bot. Gesell., xi. (1893) Gen.-Versammlungs-Heft, pp. 69–73.

† Zeitschr. f. Hygiene u. Infektionskrankh., xv. (1893) No. 1. See Centralbl. f. Bakteriolog. u. Parasitenk., xiv. (1893) p. 730.

‡ Centralbl. f. Bakteriolog. u. Parasitenk., xiv. (1893) pp. 827–45 (1 pl., 12 figs.).



were also obtained by using a small quantity of gelatin placed at the bottom of the tube and inoculated with some bacteria, and then filling up the tube with water.

In the second case a wedge-shaped layer of fluid inoculated with some bacteria is obtained by tilting up one side of a cover-glass, by inserting a piece of wire between the cover-glass and the slide. The respiration-figures obtained in this way were found to exhibit three chief types, the aerobic, the spirillar, and anaerobic. In the aerobic the mobile bacteria collect at and near the surface, beneath them being a bacterium-free zone, while the central zone is formed by a mass of resting bacteria. In the spirillar type the arrangement is reversed, the middle zone is filled with lively bacteria, the outer and central zone being either free or merely cloudy. In the anaerobic type the bacteria collect in the middle of the fluid wedge.

Besides the preceding the author describes and depicts respiration figures of three species of *Chromatium*.

**Cancer of the Ash produced by Bacteria.\***—Herr F. Noack traces this disease, which is occasionally epidemic in the ash-tree, to a Schizomycete which produces a mucilaginous mass beneath the bark, extending thence to the interior of the stem and branches.

**Streptococcus Bombycis and the Silkworm Disease.†**—Sig. L. Macchiati asserts that *Streptococcus Bombycis* is certainly the cause of the destructive disease which produces flaccidity in the silkworm larva. The germs of this microbe are constantly floating in the air, and reach the interior of the body with the food. *Bacillus Bombycis* or *Cubonianus* is only found on the death of the insect.

**Microbes in Chronic Rheumatism,‡**—Dr. Schüller has found a microbe in the synovial membrane of joints affected with chronic rheumatoid arthritis. It is a short bacillus, constricted in the middle, and can be stained by carbol-fuchsin. It grows best in the dark at about 77° F., and may be cultivated on potato and in various culture-fluids. Acute rheumatism is probably quite a different disease, but may cause the affected joints to be less resistant to Schüller's bacilli.

**Alexocytes.§**—Mr. E. H. Hankin, in answer to the criticism of Metschnikoff on the theory of alexocytes, || admits that in describing the granules in leucocytes as eosinophilous he erred, and withdraws this term in favour of amphophilous, or pseudo-eosinophilous. With this exception the author thinks that Metschnikoff's criticisms do not require answering, though he quotes facts in favour of his arguments, and points out that the objection as to whether alexins have an actual existence gives him little concern, as numerous proofs of their existence have been given by various writers. The objection against a cell origin of alexin from the absence of cells in the aqueous humour is disposed of by ask-

\* Zeitschr. f. Parasitenk., iii. (1893) p. 193 (1 pl.). See Bot. Centralbl., lvi. (1893) p. 311.

† La Staz. sperim., xxiii. (1892) 11 pp. See Bot. Centralbl., lvi. (1893) p. 203. Cf. this Journal, 1892, p. 661.

‡ Brit. Med. Journal, No. 1717 (1893) p. 88.

§ Centralbl. f. Bakteriöl. u. Parasitenk., xiv. (1893) pp. 252-7. Cf. this Journal, 1893, p. 515.

|| Cf. Ann. Inst. Pasteur, vii. (1893) p. 50.

ing if this fluid does not come from cells, and turning his opponent's flank by discussing if it really possess bactericidal properties. The experiments of Metschnikoff on the immunity of guinea-pigs to *Vibrio Metschnikovi* are recalled in support of the alexocyte theory. As to the objection of making a general theory of immunity from experiments in vitro, the author minimizes its force by pointing out that by suitable means the granules can be driven from the cells into the plasma, which then shows increased bactericidal power, and he concludes by referring to the observations of Kanthack and Hardy, who found that the bacteria were rendered harmless by the action of alexin granules before they were attacked by the phagocytes.

**Ammoniacal Fermentation of Earth.\***—MM. A. Müntz and H. Condon have made experiments for the purpose of ascertaining whether the formation of ammonia is due to chemical or microbic action, or is the result of the conjoint action of these forces. Earth from different localities (Champagne, Limousin, Joinville) was first sterilized at 120°. Equal quantities, 100 grm., of sterilized and non-sterilized earth were mixed with like quantities of dried blood, and after 67 days the amount of ammonia formed was determined. No ammonia was formed in the sterilized mixture, while by the three samples of non-sterilized earth, 111, 41, and 59 mgrm. of ammonia were formed.

Further experiments were made in order to ascertain if the production of ammonia was due to the action of a special ferment, or was to be ascribed to several or indeed any of the microbes inhabiting the soil. Seven different micro-organisms were isolated, and experiments made from pure cultivations of these in bouillon and in earth mixed with inorganic manure. All these organisms produced ammonia; and as these seven species, isolated haphazard, were able to do this, the authors consider it a legitimate conclusion that the ammoniacal fermentation of the soil is, unlike the process of nitrification, a function common to the various micro-organisms infesting it.

**Microbes and Fatty Matter.†**—Prof. E. Duclaux finds that microbes protect fatty matter against the too intense action of the oxygen of the air. This protective action would appear to be due to the fact that saponification is notably increased under the influence of certain micro-organisms, while oxidation predominates under circumstances which prevent the development of these microbes; thus, for example, when cheese is kept in the cold oxidation prevails and saponification proceeds very slowly. Both these destructive processes seem to act on fatty substances when exposed to the air simultaneously, though independently one of the other, and each process is of a different nature, saponification splitting up the fatty substance into fatty acids and glycerin, while oxidation acts first of all on the oleic acid, though it eventually attacks the whole mass. The author's researches were undertaken at the instance of a large cheese manufacturer who tried to postpone the maturation of newly-made cheeses by keeping them at 0°. The result was that the cheeses did not ripen, but acquired that soapy tallowy taste which fatty substances acquire as the result of oxidation.

\* Comptes Rendus, cxvi. (1893) pp. 395-8.

† Ann. Inst. Pasteur, vii. (1893) pp. 305-24.

**Chromogenic Water Bacteria.\***—Dr. O. Voges describes two pigment bacteria which were obtained from soil-water. One of these, *Bacillus cæruleus*, produces a grey-blue pigment. It is a rodlet 0·9–1·4  $\mu$  long and 0·7–0·9  $\mu$  broad. It is easily stained with anilin-water-fuchsin, methylen-blue, or gentian-violet, but is decolorized by Gram. Hanging-drop cultivations showed that it possesses lively movement. Stained by Loeffler's method, a flagellum thrice as long as the bacterium and having 2 or 3 turns showed itself. The formation of pigment was found to depend on the presence of air, and it occurred on most media. It was found to be soluble in water or alcohol, but not in ether or chloroform. The bacterium grew well in all the usual media.

*Bacillus indigoferus*, isolated from the same source, is an organism 0·18  $\mu$  long and 0·06  $\mu$  broad. Cultivated in bouillon it forms a scum consisting of rodlets, the interior of which is of a violet-blue hue, just as if they had been stained with gentian-violet; it is a mobile organism, and possesses a flagellum thrice as long as the bacillus itself. The bacillus was found to grow well on the usual media.

**Presence of *Diplococcus pneumoniae* Fraenkel, and of *Streptococcus pyogenes* in Osteomyelitis and Periostitis.†**—Drs. Fischer and Levy have enriched the literature of osteomyelitis and periostitis unconnected with staphylococci by four cases. In two of these *Diplococcus pneumoniae* was found. Both cases occurred in young children (7 and 16 months), and in neither was there any necrosis. One case ended in fatal meningitis, and was examined microscopically and bacteriologically. In the other the micro-organism was farther identified by experiments on animals.

From two other cases of osteomyelitis the author isolated *Streptococcus pyogenes*. Both of these did well, though a considerable thickening of the limb remained.

**Relations of Friedlaender's *Pneumobacillus* and of the Lactic Ferment with *B. lactis aerogenes* and *B. typhosus*.‡**—Profs. J. Denys and J. Martin conclude that the pneumobacillus of Friedlaender and *Bacillus aerogenes* are merely varieties of the same species. The authors began their researches with four different pneumobacilli, and the only essential differences they observed between these and *B. aerogenes* were that the latter developed faster and more luxuriantly on artificial media, except on potato, whereon *Pneumobacillus* developed as rapidly as the bacillus from the intestine. Cultivation in milk brought out the fact that there was a difference in the vitality, not only as between the pneumobacilli and the *B. aerogenes*, but also between different specimens of pneumobacilli. By successive cultivations in milk the differences gradually disappeared, and the pneumobacilli were found to coagulate milk just as quickly as *B. aerogenes*. On the rabbit, the dog, and the guinea-pig, the same pathogenic action and anatomical lesions resulted from the action of either of these organisms. For these and other reasons the authors find that it is unnecessary to make two distinct species of them. On making a second series of experiments, the authors found

\* Centralbl. f. Bakteriol. u. Parasitenk., xiv. (1893) pp. 301–15.

† Deutsche Zeitschr. f. Chirurgie, xxxvi. (1893) Nos. 1 and 2. See Centralbl. f. Bakteriol. u. Parasitenk., xiv. (1893) pp. 434–5.

‡ La Cellule, ix. (1893) pp. 261–93. Cf. this Journal, 1893, p. 678.



that their pneumobacilli had become profoundly modified. They had lost the power of developing gas from glucose and lactose, and the growth on potato had become scarcely visible. Hence there was a striking approach towards *B. typhosus*, though they still continued to coagulate milk and to decompose lactose; and this resemblance would furnish some support to the doctrine of Rodet and Roux, viz. that *B. coli communis* and *B. typhosus* are identical. The authors confirm the statement of Wurtz and Leudet as to the identity of the lactic ferment and *B. aerogenes*.

**Anthrax in Rats.\***—Dr. K. Müller's experiments with anthrax were made on rats, most of which were bred by crossing the white with the dark grey rat; and he used white, black and white, grey-white, grey, and black rats, all of which therefore had different degrees of resistance. The food was chiefly bread, though one lot was confined to meat. The inoculation material was agar cultures and spleens of animals dead of anthrax. The subcutaneous inoculations were made with a loopful (1 mm. diam.) of agar culture in 1 ccm. of water. Sometimes the skin was snipped up without drawing blood, and some anthrax-spleen rubbed in. The author's results may be summed up as follows. About four-fifths of the rats inoculated with small doses of anthrax die. Of the more resistant fifth, the majority succumb on further inoculation. Previous inoculation confers no immunity, indeed rather a susceptibility. Black rats are more resistant than grey, grey than black and white, and the latter than white; the degrees of resistance would be about  $5\frac{1}{2}$  —  $2\frac{3}{4}$  —  $1\frac{3}{4}$  — 1. Yet even among the white, and black and white races, individuals are found with a degree of resistance which would be represented by the figure 5; and taken generally, rats exhibit considerable difference in their resistance. The difference in individual resistance may be explained partly by breeding, and partly by feeding (this amounts to heredity plus environment).

The appearances observed post mortem are roughly divided into two types, though there is no strict line of demarcation. In the white bread-fed rats the spleen is very large, often enormous, the liver is increased in size, and there is intestinal catarrh. In the dark races, fed on flesh, the spleen is little if at all enlarged; there are serous, often sanious, exudations in the pleural sacs compressing the mottled lungs. In both cases the bladder is filled with bloody urine, and the kidneys are swollen.

A third type, called chronic rat-anthrax, was observed in the parti-coloured animals who succumbed to the fourth, fifth or sixth inoculation. The chief characteristics were numerous small necroses, chiefly in the liver, but some in the spleen.

The author found that alkaline methylen-blue was the most suitable stain, and the longer the disease had lasted, the more difficult it became to demonstrate the bacilli. The bacilli were always free and never enclosed in phagocytes. The author agrees that the organism of the rat is endowed with bactericidal properties, but these are neutralized by the metabolic products of the anthrax-bacilli. The immunizing principle is not associated with the serum, but is a product of the cells of the body. Though leucocytes may share in conferring immunity, it is

\* Fortschr. d. Med., 1893, pp. 225 and 309. See Centralbl. f. Bakteriol. u. Parasitenk., xiv. (1893) pp. 779-83.



not by phagocytosis, but only in the same power as is possessed by the cells of the whole organism. The process is a chemical, rather than a morphological one.

**Destruction of Field Mice by means of Pathogenic Microbes.\***—In February 1893, an epidemic of field mice was observed by M. J. Danysz at Charny, Seine-et-Marne, and on bacteriological examination, the constant presence of a micro-organism in the organs and secretions of the body was revealed.

The organism, when stained by Gram's method, was seen to be a small bacillus with rounded ends, the polar points often being more deeply coloured. It developed well and quickly on the usual cultivation media, though agar, on the surface of which it spread in a uniform yellowish-grey layer, seemed to suit it best.

Inoculated on healthy mice (*Mus arvalis* and *M. sylvaticus*) it gave rise to the same disorder as the natural disease, and all the animals died. Inoculation experiments showing that it was not pathogenic to other animals such as poultry, cats, dogs, and cattle, it was determined to attempt the destruction of small rodents in a district much infested and ravaged by them.

Twenty agar tube cultivations, 5-6 days old, were mixed with 50 litres of water and about 80,000 pieces of bread 1 ccm. square were soaked therein. One piece of bread was placed close to every sixth hole. Three days afterwards the fields were found strewn with the dying and dead bodies of mice.

**Vibrio resembling Cholera Bacillus.†**—Dr. F. Kiessling isolated from a sample of water sent from the Altona waterworks a vibrio having some resemblance to the cholera bacillus. The water was suspected because, a few yards from it, four persons had died of cholera. The vibrio is a plump rodlet with rounded ends, 1.5-2.0  $\mu$  long and 0.6  $\mu$  thick. At room-temperature it is slightly curved and exhibits well-marked comma-forms. When incubated involution forms are frequent. There is a flagellum at one end. Between this organism and the cholera vibrio are well-marked differences. It grows but slowly in neutral pepton solution. There is no growth visible to the naked eye on potato. It does not give the cholera red reaction.

**Vibrio danubicus.‡**—Dr. A. Heider describes a vibrio which was isolated from Danube water, having characters extremely like that of the cholera bacillus. In young cultures the comma form having a moderate curve and rounded ends is far more frequent than the *sigma*-shape, while in the older cultivations long screw-like forms are seen. In short, the morphological characters vary with the age of the culture and the composition of the medium, natural or artificial. In hanging drops lively movements are visible, the motile organ being a flagellum  $1\frac{1}{2}$  times as long as the vibrio, with two or three turns; each individual possesses one flagellum at one pole. On gelatin plates this vibrio grows quickly, and in the earlier stages the colonies are remarkably like those

\* Comptes Rendus, cxvii. (1893) pp. 869-72.

† Arbeit. Kaiserl. Gesundheitsamte, iii. (1893) pp. 430-8. See Centralbl. f. Bakteriolog. u. Parasitenk., xiv. (1893) pp. 776-9.

‡ Centralbl. f. Bakteriolog. u. Parasitenk., xiv. (1893) pp. 341-57.

of cholera; later on they resemble *V. Metschnikovi*, from which they are distinguishable by the slower liquefaction. In puncture cultivations the liquefaction appearances are extremely similar, and on agar the colonies are indistinguishable. The behaviour of *V. danubicus* was further tested in milk, potato, litmus-bouillon, pepton water, and by the iodoform reaction. Milk was coagulated in from 48-72 hours. On potato the vibrio formed yellowish-brown tufts when incubated. Litmus-bouillon was strongly reduced, a deep-blue bouillon being almost or entirely decoloured in 12-16 hours at 37°. The red nitro-indol reaction with sulphuric acid was obtained in five or six hours. When the iodoform test was applied, gelatin was found to be liquefied in four or five days. The author then gives the result of numerous experiments on animals, and it is chiefly from these that he infers that *V. danubicus* is a new species, though on the whole it is strangely like cholera vibrio, and has many features in common with *V. Metschnikovi*.

**Viability Period of Diphtheria.\***—Dr. R. Abel narrates a case of diphtheria, the chief interest in it being the possibility that the contagion was nine years old. It was proved beyond doubt that the suspected source of contagion, a box of bricks, was actually infected with diphtheria, and that the diphtheria poison was at least six months old. After considering the question from the light of other cases, the author rejects the period of nine years on account of its improbability, for at present about twelve months is the longest period through which the bacilli of diphtheria have been known to survive.

**Diagnostic Value of the Soluble Products of the Microbe of Peripneumonia bovina.†**—M. S. Arloing states that pneumobacillin, a fluid prepared from *Pneumobacillus liquefaciens* on lines similar to those used in the preparation of tuberculin and mallein, manifests, when injected into the connective tissue of the ox, goat, and guinea-pig, inflammatory, hyperpyrexial, and congestive properties, phenomena similar to those produced by the filtered pulmonary serum or by filtered bouillon cultivations. Like tuberculin, it possesses the property of exciting inflammatory reaction about old peripneumonic lesions, e. g. synovitis. So far as the experiments have gone, they simply indicate that animals affected with chronic peripneumonia are more sensitive than healthy animals to the action of pneumobacillin.

**Mixed Infection from Tubercle Bacilli and Pyogenic Cocci.‡**—Dr. M. Jakowski records some interesting observations made on the blood of patients in the hectic conditions of phthisis. Cultivations were made with the blood, drawn from the fingers and obtained with antiseptic precautions, on agar and gelatin plates, and also on oblique agar tubes. The microscopical preparations were stained with aqueous solutions of gentian-violet and methylen-blue.

*Staphylococcus pyogenes aureus* and *Streptococcus pyogenes* were found alone or in conjunction. From the small number of observations (nine) it is impossible to draw a positive conclusion, but as the author's results

\* Centraltbl. f. Bakteriologie u. Parasitenkunde, xiv. (1893) pp. 756-61.

† Comptes Rendus, cxvi. (1893) pp. 166-9.

‡ Centraltbl. f. Bakteriologie u. Parasitenkunde, xiv. (1893) pp. 762-6.

agree in the main with those of previous observers, their accuracy may be admitted.

**Microbic Origin of Purulent Surgical Infection.\***—MM. S. Arloing and E. Chantre, after reciting their views at length, sum them up as follows:—The essential agents of purulent surgical infection are the ordinary microbes of suppuration. Should other microbes be present in the lesions with any frequency, they are to be regarded in the light of complications, and not as necessary factors in the development of the purulent infection. A purulent infection can only result when the streptococcus (the authors confine themselves to that form) is endowed with the same virulence as it possesses in the acute and severe forms of puerperal septicæmia, and not with that which it exhibits in simple phlegmon or erysipelas.

Though ætiological relations between purulent infection, puerperal septicæmia, and erysipelas may be suspected, yet it cannot be proved where and how the change in the pathogenic properties of the streptococcus, productive of different clinical conditions, is effected.

\* Comptes Rendus, cxvii. (1893) pp. 324-7.





## MICROSCOPY.

## a. Instruments, Accessories, &amp;c.\*

## (1) Stands.

FIG. 17.

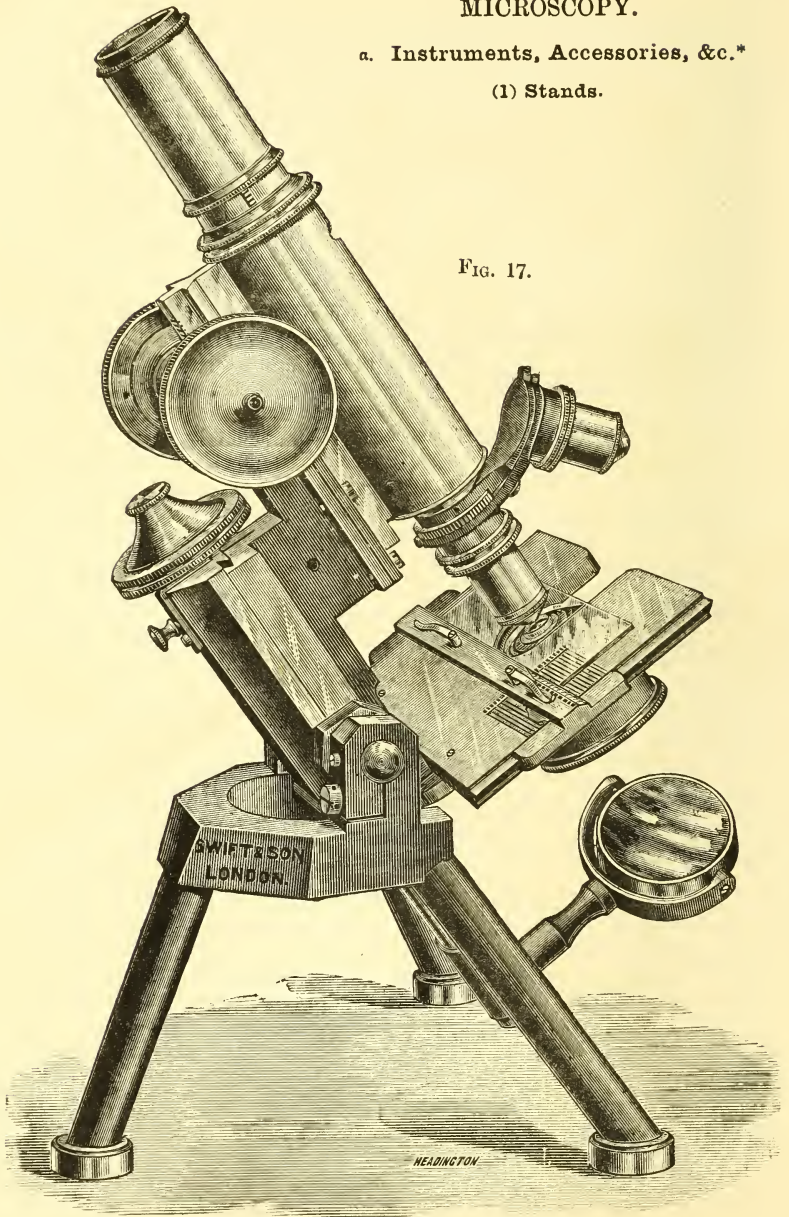

\* This subdivision contains (1) Stands; (2) Eye-pieces and Objectives; (3) Illuminating and other Apparatus; (4) Photomicrography; (5) Microscopical Optics and Manipulation; (6) Miscellaneous.



Swift's New Histological and Physiological Microscope.—This instrument, represented in figs. 17 and 18, is specially designed to meet the requirements of students in general biological work. The optical

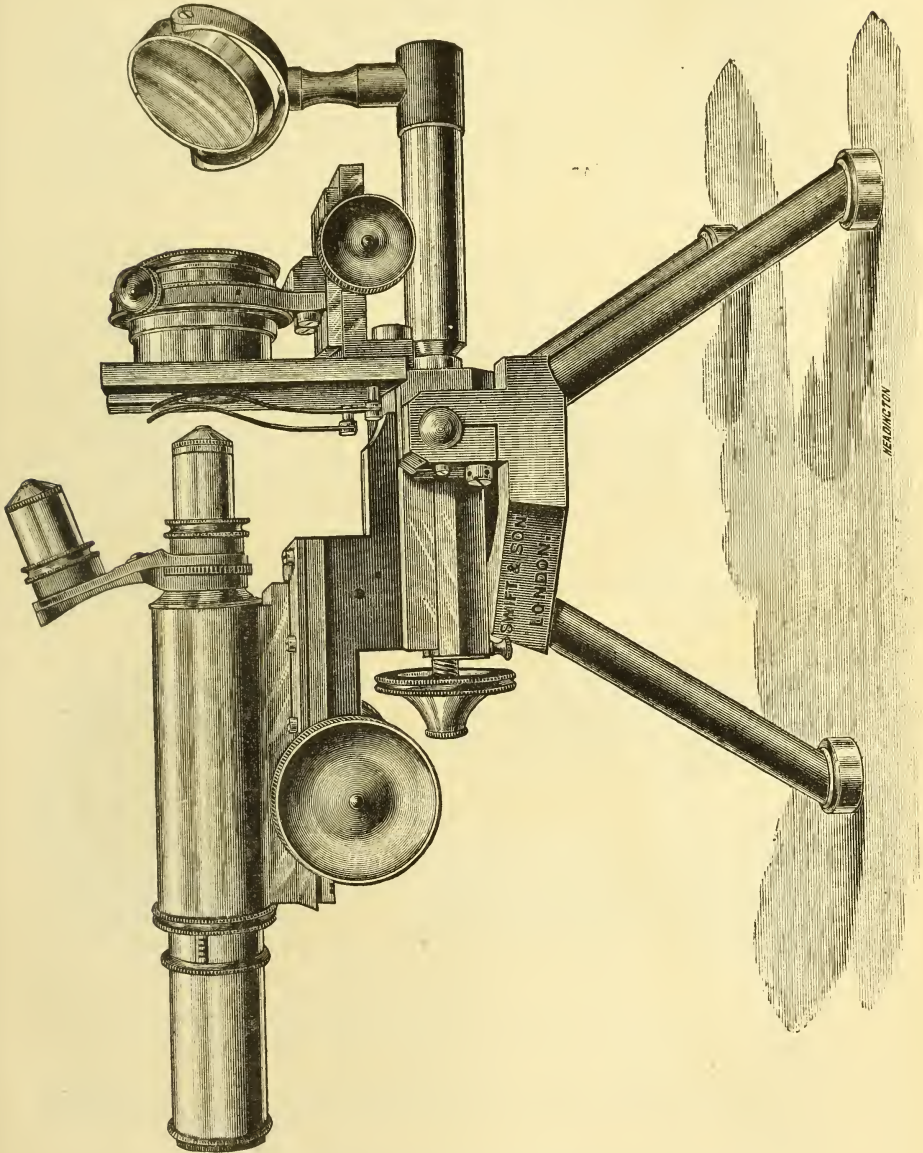

tube is provided with a draw-tube divided in mm. The coarse-adjustment is by the spiral rack-and-pinion motion patented by the makers, while the fine-adjustment is by micrometer-screw of entirely new cons

struction. The action of the latter, it is claimed, is direct and perfectly steady with the highest amplification.

The stage is large and of the horse-shoe form; below it is a fitting for receiving all illuminating apparatus.

The stand is a modified form of Powell and Lealand's tripod.

In fig. 18 the Microscope is represented in the horizontal position, with the addition of a substage provided with universal adjustments for centering and focusing the illuminating apparatus. The special form of the tripod-stand renders the Microscope very steady when used in the horizontal position for photomicrographical purposes; for, as seen in the figure, the pillar of the fine-adjustment rests squarely on the top of the tripod, and the centre of gravity falls well within the triangle formed by the supports.

**New Substage.\***—Mr. G. Whitfield Brown, jun., describes a substage made by Zentmayer, of Philadelphia, according to his specifications, which "has given perfect satisfaction."

The substage consists of a double elbow with two arms, each of which contains a tubular holder for receiving accessory apparatus. A centering set-screw secures it to a bracket which slides or is moved by rack and pinion on the tail-piece. Between the upper and lower holders is a removable iris diaphragm. The lower arm of the substage is provided with a revolving plate, upon which there is a sliding plate moved by rack and pinion. In the central opening of this sliding plate the iris diaphragm fits by means of a flange, and can be readily inserted and removed. For the iris diaphragm may be substituted revolving receivers for the reception of selenites, mica-plates, diaphragms, &c.

In this substage the Abbe condenser is fitted into the upper holder from above.

### 3) Illuminating and other Apparatus.

**Production of Exact Micrometer-Screws.†**—Dr. Hugo Schroeder gives a detailed description of the mode of production of exact screws. A short account of the process employed will be found in the *Encyclopædia Britannica*, 9th edition, Part 83, p. 552.

The principle of the method consists in first preparing as exact a screw as possible by the best of the ordinary methods, and then in eliminating the errors by systematic grinding and polishing.

For this purpose a nut (fig. 19) is prepared of brass, or better, of Bessemer steel, the length of which is to that of the screw as 11 to 9. The nut is made up of four segments *a* (fig. 20), which are fastened together by means of the collars *b b*, the rings *d d*, and the screws *c c*, so that during the polishing the screw and the nut may be always kept in contact. The long nut is brought slowly over the screw and moved backwards and forwards over it after oil and emery have been introduced. Towards the end of the grinding finer emery is used, and finally oxide of iron only.

Copies of a perfect screw thus prepared can be made by the following process:—The normal screw is set in the support instead of the ordinary

\* *Amer. Micr. Journ.*, xiv. (1893) pp. 347-50 (2 figs.).

† *Zeitschr. f. Instrumentenk.*, xiii. (1893) pp. 217-29.

guiding screw, and is provided with a toothed wheel which engages in another toothed wheel attached to a so-called "Spitzenfutter" screwed on the spindle of the lathe. The screw is then cut slowly and carefully by the tool C (fig. 21), consisting of a three-sided prism, which can be easily removed for sharpening by loosening the steel wedge B, and can then be replaced in the holder A with the cutting plane in exactly the same position as before.

The author also describes the so-called "Spiegelfühlhebel," an instrument which may be used for all purposes of very fine adjustment and measurement, as e. g. in the fine-adjustment of large Microscopes.

FIG. 19.

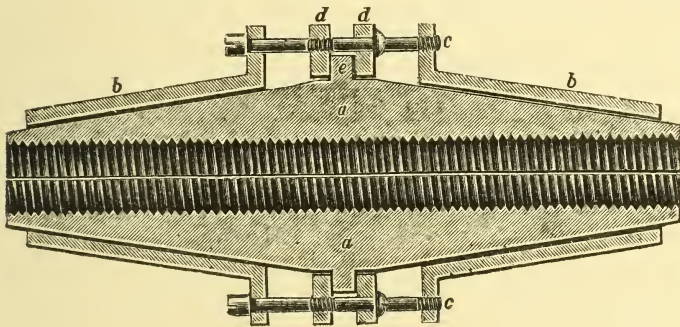

FIG. 20.

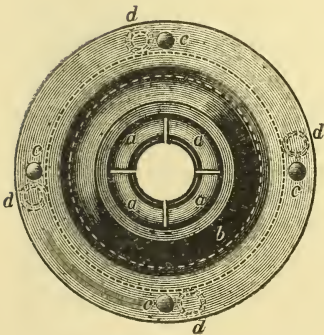
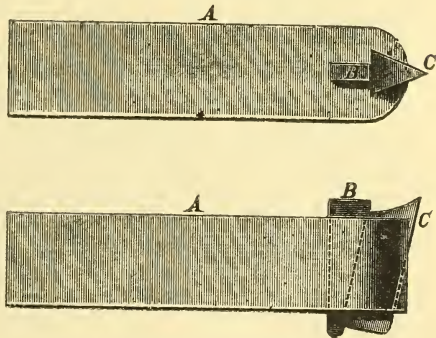

FIG. 21.



The micrometer screw moves in a nut which is regulated by screws, and is terminated by a small, hard, highly polished ball. This screw carries a nut, on the edge of which is cut a screw-thread (usually 100 teeth) in which an endless screw engages. This endless screw is fixed in a metal piece, and carries on its head a division; so that with this arrangement  $1/1000$  of a screw rotation can be measured, i. e. in this case  $1/20,000$  mm. The screw is not in direct connection with the



nut, so that it can be used without having any influence on the fine-adjustment. To bring the fine-reading apparatus into play it is only necessary to turn one screw, which then by means of a screw segment presses on another screw. With this instrument it is possible to measure the depth of the furrow produced on a piece of glass by making a finger-stroke upon it with some fine polishing powder.

For the cutting of normal screws the author recommends a tool which he calls a "Schneideneisen." The teeth of the tool cut the thread quite gradually up to the right depth, for the first tooth only cuts a slight dent in the material, which each of the succeeding teeth deepens by a certain amount.

**Construction of Silvered Lens Mirrors.**—Mr. Edward M. Nelson contributed the following to the meeting last December:—

Although the idea of making a mirror by silvering one side of a convex lens is an old one (probably dating back more than 100 years),\* it has more than once been reinvented and brought forward as something quite new. It is, however, strange that such a simple, excellent, and cheap contrivance, and one so eminently suited for microscopical purposes, should have received so little attention.

With the object of keeping the price of the Farmer's Microscope as low as possible, I had two silvered equiconvex lens mirrors fitted to it, one being for substage, and the other for superstage illumination.

While experimenting with these mirrors, their practical usefulness so greatly impressed me that I at once proceeded to investigate the theory of their action. On looking up the subject, I was fortunate to find in an article by Sir D. Brewster a passing notice of a reflecting telescope, designed by the late Astronomer Royal, which was composed of silvered lenses.

Referring to the original paper in the 'Cambridge Philosophical Transactions for 1822,' we find that Sir G. Airy was led to investigate the optical principles of lens mirrors, both on account of the difficulty he experienced in obtaining flint discs for achromatics, and also because he found that metallic specula were liable to tarnish.

He had two Cassegranian telescopes made from formulæ he had computed. After trial he said that "the image of a star or planet was surrounded with radiations which made the telescope quite useless for practical purposes;" the reason of this he did not discover, but he did not think it arose from any residual chromatic error.

In his paper the foci, radii, and refractive indices of the glasses are not given, but there is an able mathematical analysis of the destruction of the aberrations of one lens mirror by those of another, which was of assistance.

The problem now before us, viz. the aplanatism of a single-lens mirror for parallel rays independently of chromatic aberration, though fortunately simpler, nevertheless requires a cubic equation for its mathematical solution. I say mathematical solution, because with much additional labour, a result sufficiently near for all practical purposes might be obtained without mathematical knowledge. The data,

\* See this Journal, 1890, p. 88.



however, given at the end of this paper have not, so far as I am aware, been published before.

In order that all the points may be perfectly clear, a few lines of elementary optics are necessary. It is obvious that the rays pass twice through the lens and undergo one reflection from the mirror. If  $f$  be the focus of the lens, and  $f'$  that of the mirror,  $F$  the focus of the combination, when its thickness is neglected, will be

$$\frac{1}{F} = \frac{2}{f} + \frac{1}{f'} \quad (i.)$$

Now if  $\mu$  is the refractive index,  $r$  the radius of the incident surface, and  $s$  that of the silvered surface,  $f$  the focus of the lens taken alone will be  $\frac{rs}{(\mu - 1)(s - r)}$  and  $f'$  that of the mirror  $\frac{s}{2}$ .

Putting these values in equation (i.) we have in terms of the radii the focus of the entire system.

$$F = \frac{rs}{2\{\mu(s - r) - s\}} \quad (ii.)$$

When  $\mu = \frac{3}{2}$

$$F = \frac{rs}{s - 3r} \quad (iii.)$$

Therefore, if  $\mu = \frac{3}{2}$ , and the lens is equiconvex  $s = -r$ , then  $r = 4F$ ; but if the lens is a plano-convex,  $r$  being the plane side  $= \infty$ , and  $s = 3F$ , that is the radius of the silvered side is four and three times the focus respectively.

With regard to the aberration of lens mirrors, it is obvious that in the equiconvex form an amount of refraction equal to that of an equiconvex lens is obtained with only a fourth of the depth of curvature.

In the plano-convex form the incident parallel rays pass through the plane surface without aberration, but then there is the spherical aberration of the concave mirror, as well as the aberration on the final emergence of the rays at the plane surface; in addition to this, the radius of the curvature of the mirror is less in the proportion of 3 to 4; nevertheless, calculation shows that the aberration of the plano-convex is less than that of the equiconvex form. For example, when  $y$  is the semi-aperture,  $F$  the focus, and  $\mu = \frac{3}{2}$ , the aberration of an equiconvex lens mirror is  $\frac{32 \cdot 4 y^2}{r^3}$ , or  $\cdot 5 \frac{y^2}{F}$ , that of a plano-convex mirror lens being  $\frac{8 \cdot 5 y^2}{s^3}$ , or  $\cdot 315 \frac{y^2}{F}$ ; whereas the aberration of an ordinary plano-convex

bull's-eye when in its best position is  $1.16 \frac{y^2}{F}$ , viz. more than double that of the equiconvex lens mirror.

Now, if we consider carefully the action of the plano-convex lens mirror, we see that we have the aberration of the concave mirror plus that of the plane surface, these aberrations being positive, or the same as those of converging lenses; it is evident that if we wish the system

FIG 22..

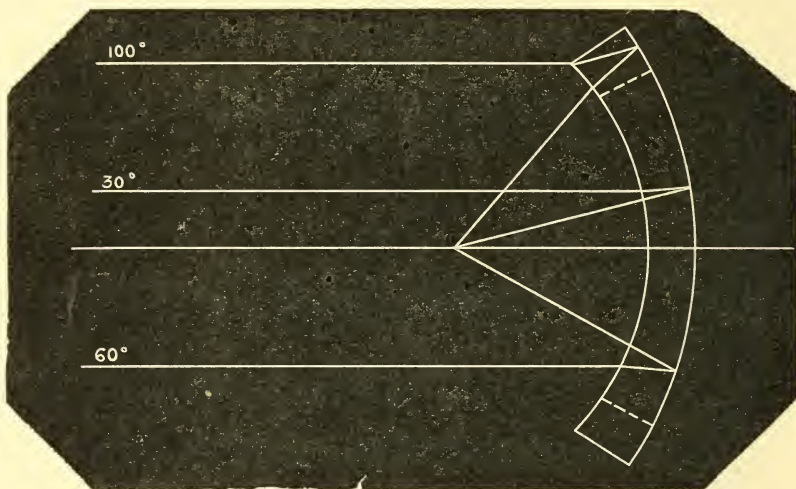

to be aplanatic we must neutralize these positive aberrations by introducing the negative aberration of some concave surface. Suppose we make the first surface concave, and of a radius equal to the focus of the system. It is obvious, in the first place, that there will be no aberration on the emergence of the rays, because they will be normal to the surface, and, further, the aberration of the first curve for the incident parallel rays will be of an opposite kind to that of the concave mirror. We may therefore conclude, without entering into any mathematical calculation, that the total aberration of such a system will be greatly reduced, and also we may infer that aplanatism is a possible condition. Hence the problem in the determination of the ratio of the curvatures of the incident and silvered surfaces. Following out the argument above, if we put  $F = -r$  in equation (iii.) we shall find that  $\frac{r}{s} = \frac{2}{3}$ ; as both are negative, the lens will be a diverging meniscus. We have therefore arrived at the following conclusions:—(1) That aplanatism is possible. (2) The form of the lens will be a diverging meniscus. (3) That the ratio of the curvature is about  $\frac{2}{3}$ . Further than this by mere inspection we cannot go; but, as hinted above, by a laborious method of trial and

error, a result sufficiently correct for practical purposes might be arrived at.

By solving a cubic equation,\* the details of which possess no special interest, the ratio of the radii is found; then by means of equation (ii.) we obtain this final result:

$$r = -1.165 F \quad \text{and} \quad s = -1.608 F.$$

There are, however, some quantities which, for the sake of simplifying the calculation, have been neglected, and one of these is the thickness of the lens. If a lens mirror is of large size the thickness must be considerable, in order that it may stand the strain of grinding and polishing, and as thickness influences the aplanatism of the system we cannot disregard it.

Further, one of the great advantages of the lens mirror is, that it permits a very wide-angled system to be usefully employed, because no ray makes an excessive angle with its normal; the incident ray makes the largest angle, and that must always be less than half the angle of aperture. The effect of thickness and large aperture can be very well seen by making a drawing of a lens mirror on a large scale, and by tracing out wide, medium, and narrow angled rays.

If the lens is drawn on the above formula, and with no thickness, it will be seen that the medium and narrow rays have both been spherically aberrated to the extent of  $-\frac{F}{66}$ , but the extreme ray will be further displaced to  $-\frac{F}{40}$ .

If in a drawing of a lens mirror, on the same formula, which possesses sufficient thickness for practical construction, say  $\frac{F}{5}$ , we

have three similar rays, we shall obtain  $-\frac{F}{12}$  for the values of the aberration of the medium and narrow-angled rays, and  $-\frac{F}{8}$  for that of the

extreme ray. From this we learn that the results obtained by the solution of the cubic equation are not suitable for the construction of an aplanatic lens mirror. A glance at the drawing of the thick lens will show that the curvature ratio is not large enough, and on trial a ratio of 2:3 will be found to yield far better results.

No great difficulty will be experienced in determining curves that will bring an extreme and a central ray to an identical focal point; but it is by no means easy to find the precise curves that will render a lens mirror strictly aplanatic for all zones. I thought the subject sufficiently important to justify the trouble of working out the following curves for three different thicknesses of lens mirrors. These curves, when drawn on a large scale and tested by tracing three rays for apertures of 100°, 60°, and 30°, show perfect aplanatism. A slight deviation from these curvatures will destroy the aplanatism. It is probable that errors arising from the thickness of the lenses were the cause of the fluffiness which Sir G. Airy observed in his telescopes, as he distinctly states that no

\* The equation is given in some of the text-books, but not its solution.

allowance was made for thickness in his calculations. Let  $r$  be the radius of the incident, and  $s$  that of the silvered surface,  $t$  the thickness, and  $d, D$ , the diameter when the mirror has an aperture of  $80^\circ$  and  $100^\circ$  respectively,  $F$  being the true focus, and the refractive index  $\mu = 1.516$ , then the following are the formulæ for aplanatism :

$r$	$s$	$t$	$80^\circ$ $d$	$100^\circ$ $D$
$- 1.086 F$	$+ 1.652 F$	$\frac{F}{5}$	$1.26 F$	$1.56 F$
$- 1.086 F$	$+ 1.627 F$	$\frac{F}{6.3}$	$1.3 F$	$1.58 F$
$- 1.089 F$	$+ 1.611 F$	$\frac{F}{9}$	$1.32 F$	$1.61 F$

It must be remembered that the focus  $F$ , given in the above formulæ, is the true focus, measured from the silvered surface, but, to save those intending to construct a lens-mirror trouble, I have drawn out the appended table (see p. 260) of the actual radii, thicknesses, and diameters of such lens mirrors as are likely to be useful to the microscopist. In this table  $f$ , the working focus, viz. the focus measured from the incident surface, is given, instead of  $F$ , the theoretical or true focus, which is measured from the silvered surface. The diameters given in the table are the lengths of the chord of the incident surface, and as the edge of the lens should be a radius of the silvered surface (see fig. 22) the diameter of the silvered surface will be somewhat larger. If the lens is edged parallel to its axis the aperture of the mirror will be reduced. It is clear that the mirror must have a diameter greater than that portion which subtends the angle of aperture. For example, the extreme ray in the fig. makes an angle of  $50^\circ$  with the axis, but if the mirror had only just sufficient aperture to include that angle the ray would never pass out of the lens.

In the aplanatic lens mirror the chromatic aberration is less than in a bull's eye, because the greater part of the angular bending of the ray is performed by reflection instead of by refraction. In the following aplanatic lens mirrors of  $100^\circ$  of aperture,  $\frac{3}{5}$  of the total bending is accomplished by reflection without any dispersion.

If an aplanatic lens mirror be compared with a bull's-eye of two planos of best form its superiority is at once manifest.

First, the bull's-eye cannot approach the lens mirror in aperture; secondly, in the bull's-eye all the bending is accompanied with dispersion, whereas in the lens mirror only  $\frac{2}{5}$  of the total bending suffers dispersion; thirdly, the spherical aberration, even with two planos of the best form, amounts to no less than  $.36 \frac{y^2}{F}$ ; fourthly, the diameter of the bull's-eye soon reaches a limit, because of the thickness of the lenses.



Before concluding it will be as well to investigate for the sake of comparison the aberration of the commonest form of mirror, which is found in every Microscope, viz. a silvered shell of glass, in other words a lens mirror, where  $-r = -s$ . Formula (ii.) shows that when  $-r = -s, r = 2 F$ ; this is precisely the focus of a metallic concave mirror, therefore the glass part of the system has no influence at all. The equation for aberration, however, indicates a reduction in the aberration from  $\cdot 125 \frac{y^2}{F}$ , that for a concave mirror, to  $\cdot 1 \frac{y^2}{F}$ , that for the silvered shell. Practical experiments with thick shells yield somewhat different results; with a thickness of  $\frac{F}{7.3}$ , it will be found that the focus has been lengthened by  $\frac{F}{8}$ , and the aberration slightly reduced to  $\cdot 085 \frac{y^2}{F}$ .

Thickness therefore is, in this case, an advantage.

Aplanatic lens mirrors will be found useful for lieberkuhns, side reflectors, superstage and substage illuminators; they are especially adapted for parallelizing wide-angled beams, and would therefore advantageously take the place of bull's-eyes or parallelizing condensers. They would of course be invaluable for search lights and lighthouses.\*

As the manufacture of these aplanatic lens mirrors can present no difficulties but what are met with in the most ordinary optical work, I can see no reason why they should not be largely used, and I trust that this effort of mine may be the means of not only improving, but also of cheapening a common and useful portion of microscopical apparatus.

*Note.*—The radius of the silvered surface  $s$  is throughout this paper considered negative, because it is measured from the surface to the centre, that is from right to left, but in the table it is entered positive, so that it may agree with the practice of manufacturing opticians.

Fig. 22 is drawn to scale from one of the formulæ in the third block of the table, it therefore illustrates an aplanatic lens mirror of the thickest type.

The following are some of the angles of the lens mirrors of the middle block having an aperture of  $100^\circ$ . The extreme ray parallel to the axis makes an angle of  $46\frac{1}{2}^\circ$  with its normal at the incident surface. The corresponding angle in glass is  $28\frac{1}{2}^\circ$ , viz.  $13^\circ$  less than the critical angle. This ray undergoes a reflection of  $28\frac{1}{2}^\circ$ , therefore this reflected ray in glass is parallel to its normal at the incident surface. In the thin lenses of the first block the angles of the extreme rays are slightly greater, but in the third block they are a trifle less than  $28\frac{1}{2}^\circ$  in glass.

\* The following are the radii, &c., of large mirrors :—

D	$f$	$t$	$-r$	$+s$
$100^\circ$				
12.0	6.62	0.82	8.11	12.0
12.0	6.40	1.20	8.25	12.36
12.0	6.15	1.54	8.35	12.71

Two and three foot mirrors will of course have twice and three times those values respectively.

$t$	$-r$	$+s$	$d$ 80°	D 100°
·062	·339	·516	·39	·49
·125	·679	1·032	·78	·97
·187	1·018	1·549	1·18	1·46
·250	1·357	2·065	1·57	1·95
·312	1·697	2·581	1·96	2·44
·375	2·036	3·097	2·35	2·92
·437	2·376	3·614	2·75	3·41
·500	2·715	4·130	3·1	3·9
·56	3·05	4·65	3·5	4·4
·62	3·39	5·16	3·9	4·9
·69	3·73	5·68	4·3	5·4
·75	4·07	6·19	4·7	5·8
·87	4·75	7·23	5·5	6·8
1·00	5·43	8·26	6·3	7·8

$t$	$-r$	$+s$	$d$ 80°	D 100°
·017	·322	·483	·39	·47
·094	·645	·966	·77	·94
·141	·967	1·449	1·16	1·41
·187	1·290	1·932	1·55	1·87
·234	1·612	2·416	1·94	2·34
·281	1·935	2·899	2·32	2·81
·328	2·257	3·382	2·71	3·28
·375	2·580	3·865	3·1	3·7
·42	2·90	4·35	3·5	4·2
·47	3·22	4·83	3·9	4·7
·52	3·55	5·31	4·3	5·2
·56	3·87	5·80	4·6	5·6
·66	4·51	6·76	5·4	6·6
·75	5·16	7·73	6·2	7·5

$f$	$t$	$-r$	$+s$	$d$ 80°	D 100°
1	·031	·306	·453	·37	·45
1	·062	·612	·906	·74	·91
1	·093	·918	1·359	1·12	1·36
1	·125	1·225	1·812	1·49	1·81
1½	·156	1·531	2·266	1·86	2·27
1½	·187	1·837	2·719	2·23	2·72
1½	·218	2·143	3·172	2·60	3·17
2	·250	2·450	3·625	3·0	3·6
2½	·28	2·76	4·08	3·3	4·1
2½	·31	3·06	4·53	3·7	4·5
2½	·34	3·37	4·98	4·1	5·0
3	·37	3·67	5·44	4·5	5·4
3½	·44	4·29	6·34	5·2	6·3
4	·50	4·90	7·25	6·0	7·2

$f$ , Focus measured from incident surface.

$r$ , Radius of incident surface.

$d$ , Diameter of incident surface when aperture = 80°.

D, Diameter of incident surface when aperture = 100°.

$t$ , Thickness measured on principal axis.

$s$ , Radius of silvered surface.

Refractive index = 1·516.

(4) Photomicrography.

**New Method of Illumination for Photomicrographical Purposes.\***—Dr. A. Köhler's method of illumination consists in so adjusting the relative positions of the condenser beneath the object and the source of light that an image of the source is formed approximately in the plane which is the common base of all of the pencils proceeding from the projection system to the several points of the image. This plane will usually be near the hinder focal plane of the objective. The source of light must therefore be placed approximately in the hinder focal plane of the condenser. The course of the rays in this case is seen in the upper part (above the line A B) of fig. 23.  $L_1 L_2$  is the source of light in the hinder focal plane of the condenser C. O is the plane of the object in which three points  $o_1 o o_2$  are marked. The position of the object is chosen so that it is beyond the focal length of the condenser.  $p$  is the objective serving for the projection, with the iris diaphragm J in its hinder focal plane. In this plane there is produced an inverted real image  $l_1 l_2$  of the source of light  $L_1 L_2$ .

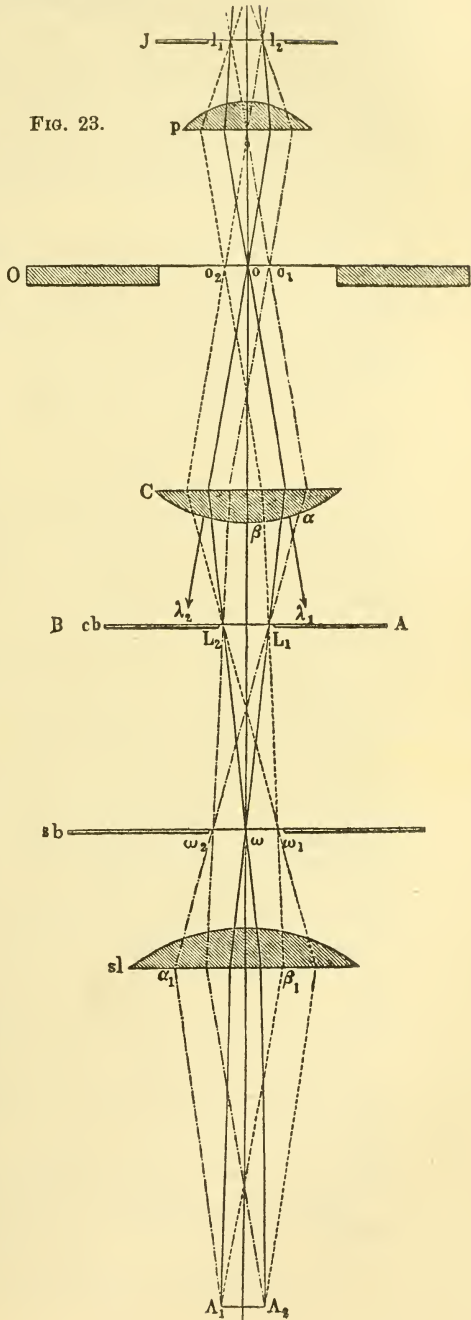

FIG. 23.

The angular aperture of the pencil which meets the plane of the object in the optic axis is equal to the angle under which the virtual magnified image of the source of light  $\lambda_1 \lambda_2$ , produced by the condenser, appears from the plane of the object. This can be regulated by diaphragms placed directly in front of the source of light. The figure shows that the illumination of the whole field of view is uniform, even if

\* Zeitschr. f. wiss. Mikr., x. (1893) pp. 433-40.

the brightness of the different points of the source is different; for every part of the plane of the object is illuminated by a pencil to which every single point of the source contributes rays.

A disadvantage to this method of illumination is that the source of light comes too close to the object. Other difficulties are that a graduation of the angular aperture of the illuminating pencil cannot be conveniently obtained, and that a sharp limitation of the illuminated surface in the plane of the object is impossible.

The author succeeds in obviating these three difficulties by the following devices.

The heating of the object due to the close proximity of the source of light is avoided by not bringing the source itself into the hinder focal plane of the condenser, but rather a magnified or diminished image of it produced by a suitable condensing lens of not too small focal length. The second difficulty is then also removed by the use of suitable diaphragms in the plane of this image.

The third difficulty is got rid of by the use of what the author calls a field of view diaphragm (*Sehfeldblende*) placed in the conjugate plane of the condenser to the plane of the object. The condenser then throws a real image of this diaphragm in the plane of the object, the size and form of which depend upon the size and form of the diaphragm.

The whole path of the rays is seen in fig. 23, taking into account now also the part below the line  $A B$ . The source of light is no longer in this plane, but far below at  $\Lambda_1 \Lambda_2$ , and  $L_1 L_2$  now represents its image produced by the condensing lens  $s l$ . The "*Sehfeldblende*" is at  $s b$  and  $\omega_1 \omega_2$  represent conjugate points to  $o_1 o_2$ .

The author adds some practical suggestions as to the adjustment of the apparatus, and choice of lenses and sources of light.

**Stereoscopic Photomicrography.\***—Dr. W. C. Borden points out the advantages offered by stereoscopic photomicrographs in representing microscopic objects in their real form through the effect of relief. The advantage generally claimed for a drawing over a photomicrograph is that the former may be constructed so as to represent an object as it appears viewed at different focal planes; but by means of stereoscopic photomicrography a similar result may be obtained, for the two most important planes of an object may be superimposed and combined so that a picture having natural relief and sharpness is produced. This result is attained by using a different focus for each exposure in the two negatives necessary for the stereoscopic picture. When viewed in the stereoscope the sharp outlines of each negative are found to override the blurred outlines of the other, and a single stereoscopic picture is produced presenting different planes of the object in sharpness and relief.

In taking stereoscopic photomicrographs the necessary lateral views of the object are obtained either by tilting the object or by using different halves of the objective for each view. With low power objectives the first method is the best to employ. In tilting the slide the axis of the tilt must be parallel with the upright axis of the object.

**Remarkable Collection of Photomicrographs.†**—Mr. K. M. Cunningham calls attention to a remarkable collection of photomicro-

\* Amer. Micr. Journ., xiv. (1893) pp. 329-33.

† Tom. cit., pp. 339-42.



graphs which were prepared about the year 1860 by a physician, Dr. Henderson, residing in Mobile, Alabama. The collection consists of sixty-five silver prints, each 6 in. in diameter, mounted on a page of an album about 12 in. square. Traced on the negative with a pin are the words "Dr. Herapath's 1/4 in. lens, 'Ross,' April 25th, 1860." The name of the object and the magnification employed are given with each photomicrograph. The collection includes specimens derived from insect or parasitic life, specimens of diatoms, specimens from plant life, specimens from sea life, and histological specimens.

**Photographing Plate Cultivations.\***—In the usual method of lighting for photographing plate cultures, says Mr. G. F. Atkinson, the finer characteristics are often lost, and in case of very transparent colourless organisms the image is throughout very dim. By covering the bottom and top of the culture dishes (Petri's capsules) with an opaque screen, the light is admitted only through the sides of the vessel, and the object is thus photographed by reflected instead of transmitted light. In this way very clear and minute details are obtained.

(5) Microscopical Optics and Manipulation.

**Theoretical Limit to the Capacity of the Microscope.†**—Herr K. Strehl gives an investigation of the limit to the resolving power of the Microscope. In his book 'Theorie des Fernrohrs auf Grund der Beugung,' he has given a theoretical proof on the ground of diffraction that the limit of the resolution of a double star occurs for the value  $Z = 3 \cdot 2$ .

Here  $Z = \frac{2 \pi r \sigma}{\lambda p}$ , where  $r$  denotes the radius of the aperture of the wave-surface,  $p$  the radius of the wave surface or the focal length,  $\sigma$  the distance apart of the two points of light in the focal plane, and  $\lambda$  the wave-length of the light, all measured in mm.

Taking the case of a pencil of rays from the Microscope objective, and considering wave-surfaces drawn as normals to the rays through the hinder focus,  $p$  will represent the so-called "optical tube-length," and  $r$  must be measured in the hinder focal plane of the objective. Now according to Abbe  $r = f a$  where  $f$  is the hinder focal length of the objective and  $a$  its numerical aperture. If  $\epsilon$  denote the minimum distinguishable distance in the object, then in the plane of the image

$$\sigma = \epsilon \frac{p}{f}.$$

We have now, corresponding to the limiting value  $Z = 3 \cdot 2$ , the following:

$$\sigma = \frac{3 \cdot 2 \lambda p}{2 \pi r}; \quad \sigma = \frac{1 \cdot 6 \lambda p}{\pi a f}; \quad \epsilon = \frac{1 \cdot 6 \lambda}{\pi a} = 0 \cdot 5093 \frac{\lambda}{a}.$$

Thus for extremely obliquely illuminated objects  $\epsilon = 0 \cdot 5 \frac{\lambda}{a}$ ; and for  $\lambda = 0 \cdot 00055$  mm. and  $a = 1$  we obtain  $\epsilon = 0 \cdot 28 \mu$ , i. e. 3570 striæ in

\* Bot. Gazette, xviii. (1893) p. 333.

† Central-Ztg. f. Optik u. Mechanik, xiv. (1893) p. 277.

1 mm., as the limit of resolving power. This result,  $\epsilon = 0.5 \frac{\lambda}{a}$ , is the same as that obtained by Helmholtz in the case of self-illuminating objects and full aperture; so that even if it were possible to make all microscopic objects self-illuminating and to observe them with full aperture, no advantage would be gained over observation with as narrow as possible and extremely oblique illumination.

(6) Miscellaneous.

**Liverpool Microscopical Society.**—From the twenty-fifth Annual Report\* of this Society we are glad to learn that its affairs are prospering, and that the ordinary meetings have been well attended. A new departure is the holding of field meetings during the summer months.

**Microscopical Society of Calcutta.**—We are glad to learn from the sixth Report of this Society (for the year 1893) that its meetings have been well attended, and that the finances are in a more satisfactory condition than they have ever been; the always present *aliquid amari* is, in this case, the regret felt at the death of the President, Prof. Wood-Mason.

The late **Mr. C. Haughton Gill, F.R.M.S.**—We regret to announce the sudden death, on February 21st, from heart disease, of Mr. C. Haughton Gill. Mr. Gill was born at Wells on the 12th June, 1841. He received the greater part of his scientific education at University College, London, and in 1858, at the age of seventeen years, gained the Gold Medal for Chemistry. The following year he took the Silver Medal for Analytical Chemistry, and about two years afterwards he was appointed assistant to Dr. A. W. Williamson, then Professor of Chemistry at the College. He remained at the College about fifteen years, when he was offered and accepted the appointment of analytical chemist and scientific manager to the firm of David Martineau and Sons, sugar refiners; when the business was a few years back turned into a limited company Mr. Gill was made the managing director, and from this position he retired only a few months ago.

While at University College Mr. Gill published a text-book of chemistry for schools, which is still esteemed as a text-book.

Some five years ago Mr. Gill devoted the greater part of his time to microscopical research, chiefly in connection with the life-history of the Diatomaceæ, and on this subject he made some important discoveries, which he communicated to our own and other Societies. But his interest in microscopy was wide and deep.

Mr. Gill joined the Society in 1889, and was elected a member of the Council in February of last year; he was also a Fellow of the Chemical Society and a member of the Quekett Microscopical Club.

The following are the papers which Mr. Gill contributed to the Journal of the Society:—

1889. Preparing Diatoms, pp. 834–5.

1890. On some Methods of Preparing Diatoms so as to exhibit clearly the Nature of their Markings, pp. 425–8, plate VII.

\* Liverpool, 1894, 8vo, xii. pp.

1891. On the Structure of certain Diatom-valves as shown by sections of charged specimens, pp. 441-2, plate VIII.

1893. On an Endophytic Parasite of Diatoms, pp. 1-4, plate I.

### B. Technique.\*

Hints in Bacteriological Technique.†—For examining bacteria in hanging drops, Prof. J. Marek instead of using a cover-glass run round with vaselin, paraffin, or the like, takes a hollow-ground or plane slide and sticks on with cedar oil a plate of black "patent-gum." The gum plate is about 1 mm. thick, and a circular hole with diameter 8-10 mm. is cut out of the middle. In the hollow is placed a droplet of water, and the cover-glass with hanging-drop put over. The cover-glass is then covered with a slide from which a circle with a diameter of 16-20 mm. has been cut out. The whole is held together by rubber rings and then examined under the Microscope, or it may be held together and kept in position by means of the stage clips.

For simultaneously staining many preparations of bacteria, a modification of the method suggested by Kutner and Tröster is advised. On a piece of plate glass 6 by 12 cm. and about 1 mm. thick are scratched vertical and horizontal lines at a distance of about 6 mm. apart. From the same kind of glass are cut four strips, 6 and 10·8 cm. long and about 6 mm. broad. Two of each of these strips are well smeared with soluble glass, and having been accurately adapted to the edges of the plate and with moderate pressure, are allowed to dry for some hours and then incubated for half an hour at 120°-150°. When cold the inner edges of the strips are smeared with soluble glass, and the drying and heating repeated. When cold the plate can be used as a slide. The bacteria are fixed by heating the slide for 5-10 minutes to 120°-130°, and then the stain is poured on into the slide-pan, the rest of the manipulation being as usual.

By enlarging the size of the glass plate and the strips to be fixed on a capsule can be made for the cultivation and examination of micro-organisms which possesses advantages over those of Petri, Soyka, and others. The glass plate should be 12 by 16 cm., and about 1-1·15 mm. thick; of these plates two are required, one serving as the lid. The strips, eight in number, are 8 and 13·2 cm. long. A capsule having a superficial area of 96 ccm. is thus formed and is especially convenient for photographic and enumeration purposes.

Doubt as to whether a certain colony has been inoculated from or not may be avoided by the use of a chart subdivided into definite areas by vertical and horizontal lines. The chart is placed underneath the capsule or plate, the position of the colony noted and then registered.

A moist chamber for plates or double capsules is conveniently made with a large glass rectangular pneumatic trough, the edge of which is protected with cotton-wool and covered with a glass plate larger than the

\* This subdivision contains (1) Collecting Objects, including Culture Processes; (2) Preparing Objects; (3) Cutting, including Imbedding and Microtomes; (4) Staining and Injecting; (5) Mounting, including slides, preservative fluids, &c.; (6) Miscellaneous.

† Centralbl. f. Bakteriol. u. Parasitenk., xv. (1894) pp. 112-4.



opening. At the bottom of the pan is placed a 1:1000 solution of sublimate forming a layer about 2 cm. high. In each corner of the trough is placed a cube made of some material which is unacted on by water or mercury (side of cube about 4 cm.). On these four cubes a glass plate rests, and the plates or capsules are placed on this. They may be put upon each other or near together, though it is advisable that they should be separated by strips of glass plate.

**Manual of Microscopical Technique.\***—Herr O. Bachmann has published the second edition of his handbook, which will, no doubt, be found useful. Whether there are not now in English manuals of various sizes and degrees of merit which will make the work unnecessary to the English microscopist is another question.

**Piersol's Histology.†**—This is stated to be the only American manual of histology that has yet been published to meet the requirements of modern methods of teaching. One great point appears to be the large number of original figures, and another the inclusion of sufficient embryology for medical students.

(1) Collecting Objects, including Culture Processes.

**Quadrangular Culture-Capsules.‡**—Dr. M. Lunkevicz uses quadrangular capsules for cultivation purposes, the sides being luted on with Leyboldt's cement, the composition of which is kept secret. This cement answers quite well and is fireproof at 200°. Capsules of this form have many advantages over the ordinary circular capsules with their uneven bottom; thus the enumeration of the colonies is more easily made either with the counter or by having the bottom of the capsule divided into squares; the distribution of the medium and of the colonies is much more regular, and as the lid and the bottom are exactly parallel and only a short distance—1 cm.—apart, the growths may be examined with Zeiss objectives  $a_3$  and A.

**Cold Stage.§**—Dr. M. Lunkevicz states that in Tiflis, where the summer temperature is often 30°–35° R. in the shade, examination of gelatin cultures is difficult unless precautions be taken for preventing the liquefaction of the gelatin. The device he has adopted is to place the capsule, &c., to be examined on a cold stage. This is nothing more than a glass box, the sides of which are parallel, and is somewhat larger than the hot stage. At one end ice-water flows in and at the other flows out.

**Behrendsen's Steam Sterilizer.||**—Herr Behrendsen's apparatus is chiefly intended for the sterilization or disinfection of surgical dressings and instruments. It consists of an ordinary cylindrical boiler and of the receiver which fits inside; the latter is of the same shape, but not of the same size. Both are closed by the same lid. The steam from

\* 'Leitfaden zur Anfertigung mikroskopischer Dauerpräparate,' Munich and Leipzig, 1893, 8vo, 332 pp., 104 figs.

† 'Text-book of Normal Histology,' by G. A. Piersol, Philadelphia, 1893, 8vo, 439 pp. and 409 figs.

‡ Centralbl. f. Bakteriol. u. Parasitenk., xv. (1894) pp. 42-3. § Tom. cit., p. 44.

|| Deutsch. Med. Wochenschr., 1893, Nos. 28 and 29. See Centralbl. f. Bakteriol. u. Parasitenk., xiv. (1893) p. 676.



the water in the boiler finds its way into the receiver through a number of holes made through the sides near the top, and escapes therefrom through a pipe running from the bottom up the side to the top.

It is stated that condensation water deposits only on the lid, and thus the articles to be disinfected are not damped. For the sterilization of instruments a special receiver is required, and this is filled with 1 per cent. soda solution and then boiled in the sterilizer. Is it superfluous to add that all this trouble might be saved by means of an ordinary tin saucepan?

**Berkefeld Filter.\***—This filter, which has been much bemoaned, has received some severe criticism at the hands of Dr. M. Kirchner, who stated that it became used up in a comparatively short time, and that it had the inherent defect of being brittle, so that, as it required sterilizing every few days, it was really an expensive luxury. The filter proper consists of calcined infusorial earth, and the special property of this material was supposed to reside in the sharpness of the edges and angles of the passages through which the water percolated; pathogenic bacteria were cut up as they hurtled by.

These remarks were replied to by Prof. M. Gruber, who seems to have expressed a favourable opinion of the apparatus. This author appears to consider that it is rather hard on filters to expect them to be immaculate, and in estimating the value of a filter he lays it down that the appearance of germs is to be assigned to one of two causes. Either the germs percolate through along with the water, and so form part of the filtrate, or they grow through. If germs percolate through the filter, the principle or the make of the filter may be considered essentially bad, but if they grow through, this is to be regarded somewhat in the light of an unfortunate accident, and one not indicative of danger.

In reply to Prof. Gruber, Dr. M. Kirchner reiterates his former statement, and points out again that while he thinks this filter is a good one as filters go, yet it soon becomes clogged, or allows the transit of pathogenic and non-pathogenic bacteria, and that it is constructed of material too brittle for general use. It possesses good features, and if it were made so as to be more durable it might be recommended for general purposes.

**Apparatus for Boiling and Cooling Water.†**—Dr. H. Laser gives a short description of an apparatus made by the Continental Gas Company in Dessau, which seems to be practical and effective. It consists of two parts, one in which the feed-water is partially heated before it gets into the boiler proper in which it is heated for ten minutes. It is then returned to the feeder through a pipe, and so becomes cooled down.

The author's observations chiefly deal with the freedom of the water from bacteria. On the whole the water is fairly well sterilized, and is delivered at a temperature varying from 15° to 25°, usually nearer the latter. The apparatus is only made to be heated by gas.

\* Zeitschr. f. Hygiene u. Infektions., xiv. (1893) p. 299. Centralbl. f. Bakteriologie u. Parasitenk., xiv. (1893) pp. 488-93, 516-27.

† Centralbl. f. Bakteriologie u. Parasitenk., xiv. (1893) pp. 749-55 (1 fig.).

**Formalin as Test for Typhoid Bacillus.\***—According to Dr. Schild formalin may be used for distinguishing between the bacillus of typhoid fever and other bacteria resembling it. After exposure of gelatin cultivation of typhoid to the vapour from 5 ccm. of formalin for 75 minutes, no results were obtained when subcultures in other media were incubated. On the other hand a water bacterium resembling the typhoid bacillus or *Bacterium coli commune* was found to be still capable of development even after two hours' exposure.

When a solution of formalin was added to the medium the difference was still more striking; the growth of the typhoid bacilli was stopped by 1 part per 15,000, while *Bacterium coli* grew strongly at 1 per 3000, and the water bacterium at 1 per 6000.

Pure cultivations of the three kinds of bacteria were also examined in the following way. To test-tubes containing 7 ccm. of sterilized neutral bouillon 0.1 ccm. of formalin was added. The formalin was therefore present in the proportion of 1 per 7000. The medium cannot of course be sterilized after the addition of the formalin, as the volatile aldehyd would be driven off by the heat. Tubes prepared in this manner were isolated with pure cultivations of typhoid bacilli, *Bact. coli com.* and the water bacterium, and then incubated. Only the typhoid tubes remained clear, those inoculated with *Bact. coli com.* or with the water bacterium becoming cloudy in 24 hours.

**Germinicidal Properties of Human Mucus.†**—According to Drs. Wurtz and Lermoyez, mucus collected with suitable precautions from the nasal mucosa possesses a bactericidal influence on some micro-organisms, e. g. *Bacillus anthracis*, the spores of which are killed after three hours' exposure to its action. Nasal mucus exerts a similar action on many other pathogenic organisms, but this action is of variable intensity.

**Antibacterial Action of Oxychinaseptol.‡**—Dr. F. Rohrer finds that oxychinaseptol (diaphtherin) has a highly inhibiting action on the development of micro-organisms, as shown by experiments with pure and mixed cultivations of pyogenic bacteria, and with pure anthrax cultivations. Oxychinaseptol in 1 per cent. solution prevents the development of *Staphylococcus pyogenes aureus* if 2-4 drops be added to 9-12 ccm. bouillon; mixed cultivation 3-4 drops, and 1-4 drops for anthrax.

**Egg-albumen as a Cultivation Medium for Micro-organisms.§**—Sig. C. Parascandole finds that hen's egg albumen is not inferior to other media for cultivation purposes. His experiments were made with *B. anthracis*, *B. typhi*, *Sp. cholerae*, *Sp. Deneke*, *Sp. Finkler-Prior*, *St. pyogenes aur.*, *Str. pyogenes*, *B. cholerae gallinae*, *M. tetragenus*. New-laid eggs were first cleaned with 90 per cent. spirit, and then washed for 10 minutes in 1-1000 sublimate, and after a second cleaning were coated with paraffin in order to preserve them. When required for experiment most of the paraffin layer was scratched off with a sterilized knife and the rest removed with turpentine. This was followed by alcohol, sub-

\* Centralbl. f. Bakteriologie u. Parasitenk., xiv (1893) pp. 717-8.

† Journ. British Dental Assoc., xiv. (1893) p. 713.

‡ Centralbl. f. Bakteriologie u. Parasitenk., xiv. (1893) p. 551.

§ La Riforma Med., 1893, p. 101. See Centralbl. f. Bakteriologie u. Parasitenk., xiv. (1893) p. 291.

limate, and again alcohol. An opening was next made at one end with a red-hot iron and the egg inverted over a sterilized test-tube. Another opening was then made at the opposite end and the contents of the egg evacuated into the test-tube. The medium was immediately inoculated and the tube closed with cotton-wool. All the tubes were kept at the room-temperature, and in all a copious growth was observed. Thus cultivated, the micro-organisms could be successfully transferred to the ordinary media.

**Egg-yolk Medium for Cultivating Influenza Bacillus.\***—Dr. M. Nastiukow prepares an artificial medium in which influenza bacilli thrive wonderfully and can be cultivated through several generations. One litre of distilled water is made alkaline by mixing with 5 gm. of 10 per cent. solution of caustic soda, and in this are dissolved 100 ccm. of yolk of egg. This is the liquid medium, and to obtain a solid one 15–25 gm. agar are dissolved in one litre of the yolk solution by boiling, and then passed through a Plantamur's filter. The media are sterilized in Koch's steam sterilizer. The cultivations were made from saliva, and on plates formed small round transparent yellowish colonies. In the liquid medium, after an incubation of twenty-four hours, little white wedge-shaped lumps sank to the bottom of the test-tube.

**Blood-Serum as Diagnostic Cultivation Medium for the Cholera Vibrio.†**—The method devised by Dr. A. Maassen for diagnosing cholera bacilli depends on the observation that these organisms flourish freely on solid serum, and that they have the power of liquefying the medium, a property in which they excel all other bacteria found in fæces or in the contents of the alimentary tract.

The procedure is very simple, and merely consists in smearing some of the soft portions of the dejecta or flakes, &c., with a platinum instrument on the serum surface of several tubes. When cholera vibrios are present the inoculated places seem as if they had been eroded in from 6–12 or at latest in 20 hours. From the holes or fissures thus formed cholera vibrios in almost pure cultivations may be fished out. The proliferation of the vibrios may often be demonstrated even before the softening and liquefaction is apparent (3–4 hours). In many cases it may be necessary to inoculate from the first to a second serum surface or a pepton-salt solution.

For the demonstration of cholera in water the blood-serum may be used directly after the preliminary pepton-salt solution. Such experiments have shown that spirilla and vibrios which do not grow on other media thrive in this solid serum, and can be easily obtained in pure cultivations. The advantages of oblique blood-serum have been found to be that in non-diarrhœic stools which contain only few comma-bacilli more material can be sown than in pepton-tubes. The liquefaction of the serum within 24 hours renders it probable that cholera vibrios are present, and if this indication be absent these organisms are not present. The cholera vibrios are not so easily overgrown by other bacteria as in other media.

\* Wratsch, 1893, Nos. 30, 32, 33. See *Centralbl. f. Bakteriol. u. Parasitenk.*, xiv. (1893) pp. 815–6.

† *Arbeiten a. d. Kaiserl. Gesundheitsamte*, 1894, pp. 122–6. See *Centralbl. f. Bakteriol. u. Parasitenk.*, xv. (1894) pp. 251–2.



**Inspissated Must and the Cultivation of Fungi.\***—Though grape must is especially suitable for cultivating fungi it has been little used, because it is only obtainable at certain times of the year and in small quantities. This inconvenience can be obviated, says Dr. J. Wortmann, by obtaining inspissated must, and he recommends that made from white grapes which has been filtered before concentration. The must is evaporated down to about one-fourth of its original bulk, and, when used, four vols. of water are added to one vol. of must. Owing to the large quantity of sugar present, about 65 per cent., inspissated must does not deteriorate and has the special advantage for experimental purposes of possessing a fixed composition (20 per cent. sugar, 0.24 per cent. acid, and 0.027 per cent. nitrogen). The amount of nitrogenous matter is from one-fourth to one-half of natural must and if desirable may be increased by adding tartrate of ammonia when diluting.

**Plate Cultivations of Anaerobes.†**—Dr. Arens uses the following simple but efficacious method for cultivating anaerobic organisms. A small exsiccator such as is found in every laboratory is nearly filled with a mixture of sand and pyrogallic acid, space being left for one or more small Petri's capsules. The plates are made in the usual way, except that it is advisable that they should consist of the contents of two tubes instead of one. A sufficient quantity of 10 per cent. caustic potash is then added to the sand and pyrogallic acid mixture, the capsule is laid on the surface, and then the exsiccator, the lid of which must fit well and be greased, is closed.

Detection of growth may be facilitated by covering the sand surface with blackened paper, and the absorption of oxygen hastened, when the plate has set, by just tilting up the exsiccator. As the absorption of air takes place quickly there is no fear either of the growth of aerobic bacteria before this has happened or of the suppression of anaerobic fungi owing to slowness of absorption. Of course, for cultivation purposes the whole apparatus is incubated.

**Method for Imparting Correct Reaction to Nutrient Gelatin.‡**—Dr. H. Timpe gives the following procedure for making nutrient gelatin. The meat broth is freed from albumen by boiling and then as usual mixed with 1 per cent. pepton, 1/2 per cent. cooking salt, and 10 per cent. gelatin. This mixture is for some time kept at a gentle heat until the gelatin is completely dissolved, and is finally allowed to boil. The boiling-hot solution is then treated with 25 per cent. caustic potash until a drop of it on a piece of filter paper moistened with an alcoholic solution of phenolphthalein leaves a red-edged spot. When a small portion and a couple of drops of the phenolphthalein solution are brought together in a test-tube there should be a distinct red colour; if not the alkali must be added drop by drop until the reaction occurs. This step must be taken with great care, for excess or defect of alkali results in an imperfect medium. Should the medium have cooled down too much during this process of neutralization it must be reboiled, but for a short time only as too prolonged boiling injures the property of gelatinization. The precipitate of calcium phosphate is rapidly thrown down in gelatin

\* Bot. Zeitung, li. (1893) p. 177.

† Centrabl. f. Bakteriöl. u. Parasitenk., xv. (1894) pp. 15-7.

‡ Op. cit., xiv. (1893) pp. 845-52.



solutions neutralized in this way, the filtrate is quite clear and 1 litre of fluid is obtainable in about 15 minutes without having recourse to the hot water filter. A portion of the filtrate, which should still give an alkaline reaction with phenolphthalein, is mixed with an estimated quantity of acid, e. g. for cholera cultures the most favourable acidity is that which is equivalent to 16 ccm. 1/10 acid in 100 ccm. gelatin.

**Sputum as Cultivation Medium for Pneumonia Cocci.\***—Dr. A. Schmidt finds by cultivating pneumonia cocci on sputum that noteworthy differences occur in the microscopical appearances. When grown in agar small bacilli, devoid of capsules, with tendency to form chains, appear, while on sputum the cocci assume the form as observed in the body and blood of infected animals. Inoculations from agar cultures to a sputum-medium reproduce the well-marked capsule bacilli. Pneumonic sputum, which is highly albuminous, was treated as serum, the only difficulty being the presence of air-bubbles. The most suitable sputum was that before the crisis. It was sterilized by heating it five times to 55° for one hour at a time.

NASTÜKOW, M. M.—Eigelb als Nährstoff für Bakterien. (Yellow of Egg as a Nutrient Material for Bacteria.) *Wratsch*, 1893, pp. 912-4, 950-1 [Russian].

#### (2) Preparing Objects.

**Method of Preparing Fresh Sections of Brain.†**—Dr. Middlemass recommends a few alterations in Bevan Lewis's excellent method of cutting fresh sections of brain. He advises that the sections should be floated out on to ice-cold water as soon as they are cut, as it prevents any considerable breaking up of the section. The result is still better if sufficient solution of permanganate of potash be added to the water to give it a fairly dark-red colour. With thick sections it is especially necessary to free them as much as possible from water. As anilin-blue-black is not a pure chemical substance, but a mixture, the best way to get a good stain is to take one which already gives a fairly satisfactory result, make a saturated watery solution of it, and pour it into a considerable quantity of absolute alcohol. This is quickly filtered, washed, and dried. The black amorphous powder which is precipitated dissolves completely in water, and gives a more delicate and a blacker stain than the original, while its action is more uniform.

**Investigation of Spermatogenesis of Salamandra.‡**—Dr. O. vom Rath reports that, in addition to better known aids to preservation of the testis, he got particularly good results with a mixture of picric-acetic acid and platinum-chloride-osmic acid. This mixture was prepared by adding 500 ccm. saturated watery and filtered solution of picric acid, 3 ccm. of acetic acid, 5 gm. platinic chloride (dissolved in about 5 ccm. of water), and 2 gm. crystalline osmic acid. The testes were placed whole in this mixture, and, after they had become hardened to a certain extent, they were punctured with a fine entomological needle, whereby the preservative fluid and, later on, stains, xylol, and paraffin were the better able to enter. After staying for three to five days in this mixture it was washed off with methyl-alcohol, and the objects were placed for several days in absolute alcohol which was several times renewed. Some

\* Centralbl. f. Klin. Med., xiv. p. 625. See Centralbl. f. Bakteriol. u. Parasitenk., xv. (1894) pp. 70-1.

† Proc. Scott. Micr. Soc., 1892-3, pp. 86-8.

‡ Zeitschr. f. wiss. Zool., lvii. (1893) pp. 102 and 3.

of the preparations thus treated were placed for one to two days in acetic acid, when subsequent staining was usually unnecessary; others were stained, either in mass or on slides, by means of Flemming's safranin-gentian-orange method.

The advantage of the picric and platinum method is that there are revealed not only the most subtle details of the nucleus, but also the finest structural relations, and that with great clearness and regularity; while there is no crumpling or swelling of the cell or nucleus. Careful measurement has convinced the author that the size and general habit of the cells and nuclei are remarkably similar to those of the living tissue.

**Preparation of Eggs of Trout.\***—Prof. H. Blanc had some difficulty in studying the eggs of *Trutta lacustris*, as they are too large to be observed directly under the Microscope, and are somewhat opaque. As they have a thick shell-membrane, and as the yolk hardens more than the blastoderm, it was necessary to discover some special method. At last, eggs fertilized by the Russian method were fixed in a mixture of 600 vols. water, 2 vols. concentrated sulphuric, 100 vols. concentrated picric, and 8 vols. glacial acetic, acids. After remaining for several hours, or even days, in this mixture, the eggs were opened in 10 per cent. acetic acid; this partly dissolved the nutrient yolk and allowed the germs to be picked out. The latter were then treated with 80 per cent. alcohol till they were completely colourless, then preserved in absolute, and afterwards stained with borax-carmin, before being placed *in toto* in glycerin or balsam. This method is recommended as giving good results even in the hands of beginners.

**Preparing Molluscan Ova.†**—Mr. E. J. Conklin finds the following to be the best method of preparing surface-views of the whole egg or embryo:—Transfer the object, previously fixed in Kleinenberg's stronger picro-sulphuric, 70 per cent. and 95 per cent. alcohol, gradually from alcohol to water; stain from five to ten minutes in a solution of Delafield's (Grenacher's) hæmatoxylin diluted about six times with distilled water, and rendered slightly acid by a trace of hydrochloric acid; dehydrate and clear in oil of cedar or cloves; mount in balsam, supporting the cover-glass, so as to prevent crushing. By occasionally softening the balsam with a drop or two of xylol, and slightly moving the cover-glass, the objects can be rolled into any position desired. This method has also been successfully employed in the preparation of surface-views of the embryo chick, English sparrow, and the eggs and embryos of Annelids and Echinoderms. One great advantage of it is that the preparations are permanent.

**Study of Spermatogenesis of Crustacea.‡**—M. A. Sabatier made use of very numerous and various reagents, always dealt with organs taken from living specimens, and used most of the known fixing reagents. In rapid teasings he found admirable Ripart and Petit's cupric fluid, whether used pure or with the addition of 1 per cent. osmic acid solution. With this and acetic-methyl-green he was able to very profitably study nuclein, whether in or out of the nucleus.

\* Ber. Naturf. Gesell. Freiburg i/B., viii. (1894) p. 163.

† Amer. Natural., xxvii. (1893) pp. 1026 and 7.

‡ Acad. de Montpellier, Mem. Sec. Sci., i. (1893) pp. 21 and 2.

Organs were well fixed and adapted for sections after having been fixed in a cold saturated solution of bichloride of mercury, to which 5, 10, or even 20 per cent. of (crystallized) acetic acid were added. Many staining reagents were used and served as controls on one another.

**Preparation of Cestodes.\***—Dr. C. W. Stiles states that the fixation of Cestodes for the Bureau of Animal Industry has lately been effected by adding 50 parts of alcohol of 70 per cent. and a few drops of glacial acetic acid to 50 parts of an aqueous solution of corrosive sublimate. The liquid was heated to 45° to 53° C., before adding; it was then allowed to cool for an hour or less; the parasites were next washed in running water and passed through 30 per cent., 50 per cent., 70 per cent., 95 per cent. and absolute alcohol.

**Investigation of Myxotheca.†**—Herr F. Schaudinn recommends strongly a mixture of hot watery sublimate solution with twice the quantity of absolute alcohol; the alcohol accelerates the entrance of the fluid, while the sublimate preserves the nucleus excellently.

**Method for Obtaining Hæmin Crystals.‡**—Mr. J. Becker describes the following method for obtaining hæmin crystals from blood-stains mixed with rust. Place some rust in a test-tube, add a little powdered ammonium chloride, and pour over them a little strong solution of ammonia. Cork the test-tube, and shake at frequent intervals. Filter, evaporate by gentle heat a little of the filtrate on a slide, add cover-glass, introduce glacial acetic acid, gently heat and allow to cool. If blood be present hæmin crystals will be seen under a high power.

**Demonstrating the Cancer Parasite.§**—Dr. P. Foà found the best way to demonstrate the cancer parasite was to fix in Hermann's solution, stain for 2-3 hours in a solution of five parts hæmatoxylin and two parts saffranin in twenty parts water, the cell nuclei appearing red and the parasites blue. The latter were distinguishable by the tone of the colour from different kinds of cell degeneration, fragmentation of the nuclei, and from paranuclei. In sixty carcinomas there were only twenty undoubted parasites, and there were special forms in each case. The author notes the presence of numerous granules, frequently in groups, and distinguished as cyanophilous and erythrophilous. He considers these are derived from the cell nuclei, from which they separate to form independent cells, and hence they may form a factor in carcinoma development.

**Preparing Sections of Living Cultivations without previous Hardening.||**—Dr. F. Winkler recommends the following method for obtaining sections of cultivations. Of paraffin the melting point of which is 42° he takes a block of a size sufficient to be easily fitted in a microtome clamp, and through this block makes a small hole with a fine cork-borer. By filling up one end with paraffin a culture-tube is made. The paraffin block is then laid in sublimate for one hour, after which

\* U.S. Dep. of Agriculture, Bureau of Animal Industry, Bulletin No. 4, 1893, pp. 13 and 14. † Zeitschr. f. wiss. Zool., lvii. (1893) p. 19.

‡ Brit. Med. Journ., 1894, No. 1729, p. 350.

§ Archivio per le Scienze Med., xvii. p. 253; Arch. Ital. de Biol., xx. No. 1. See Centralbl. f. Bakteriolog. u. Parasitenk., xiv. (1893) p. 813.

|| Fortschr. d. Med., xi. (1893) No. 22. See Centralbl. f. Bakteriolog. u. Parasitenk., xiv. (1893) pp. 814-5.



the hole is filled with inoculated medium, or the medium may be poured in first and inoculated afterwards. By stopping the opening with paraffin an apparatus for the cultivation of anaerobes is obtained. The block is sectioned under alcohol and may be stained with dilute phenol-fuchsin.

**Easy Method for Demonstrating Cholera Vibrios in Water.\***—Dr. S. Pouiklo has frequently adopted the following procedure when examining water suspected of containing cholera bacteria. From the top of the sample of water one litre is placed in a sterilized flask, and 10 per cent. sterilized bouillon added. After having been incubated for 24 hours the scum is examined by the ordinary plate method. If large incubators are available two or more litres of water can be used, and the chance of discovering the bacilli much enhanced.

**Demonstrating Protozoa and Spirilla in Drinking-water.†**—Dr. M. W. Beyerinck finds that the "bacteria-level" procedure adopted by him for describing the respiration figures of micro-organisms is very suitable for demonstrating the presence of Protozoa and spirilla in drinking-water. In this method a small quantity of nutrient gelatin, agar, &c., is placed at the bottom of a test-tube and the latter then filled up with the water to be examined. Very favourable conditions for the development and growth of micro-organisms are found in the column of water exposed to the air on one side, and to an absorbable pabulum on the other. Among the organisms isolated by this method are mentioned the following:—*Oikomonas termo*, *Spirillum undulata*, *Colpoda cucullus*, *Cladotrix dichotoma*, a *Crenothrix*, and various Bacteria.

#### (4) Staining and Injecting.

**Staining Nervous Tissue with Methylen-blue.‡**—Mr. G. H. Parker demonstrates the nervous elements of crawfish as follows. Into the ventral sinus of the animals 1/10–1/20 ccm. of a 0·2 per cent. aqueous solution of methylen-blue are injected and the animal is kept alive for about 15 hours. By that time special elements are stained dark blue, and in order to fix the colour, the parts are excised and washed with physiological salt solution and then immersed in a cold saturated aqueous solution of sublimate for about 10 minutes. The water is extracted with a mixture of 5 ccm. methylal and 1 grm. sublimate, in which an abdominal ganglion is allowed to stay for about 15 minutes.

In order to extract the sublimate and to replace the methylal by xylol the preparation is placed in a mixture of 1 vol. pure methylal, 1 vol. of the mixture of methylal and sublimate first used, and 2 vols. pure xylol. After 10 minutes the preparation is placed in pure xylol, wherein it remains for 4–5 days until the methylal is entirely replaced by xylol and the last trace of sublimate is extracted. In order to obtain a good result the preparation must remain in the xylol for a longish time because sublimate is but little soluble in this fluid. When saturated with xylol the preparation may be imbedded in xylol-balsam and inspected

\* Wiener Klin. Wochenschr., 1893, No. 14. See Centralbl. f. Bakteriol. u. Parasitenk., xv. (1893) p. 27.

† Centralbl. f. Bakteriol. u. Parasitenk., xv. (1894) pp. 10–15.

‡ SB. Gesell. Naturforsch. Freunde zu Berlin, 1892, pp. 97–8.



as a transparent object, or it may be imbedded in the usual way in paraffin and sectioned. The sections may be stuck on with the Schällibaum mixture of clove oil and collodion, and though they gradually lose colour, are quite useful for a few weeks.

**Demonstrating Axis-cylinders.\***—Dr. H. Stroebe demonstrates axis-cylinders in the central and peripheral nervous system as follows. The specimens are hardened in Müller's fluid (4–5 months and afterwards for a short time in a thermostat). The hardening is completed in spirit and absolute alcohol, and the specimen having been imbedded in celloidin sections of about  $10\ \mu$  are cut in the usual manner. The sections are stained in a saturated aqueous solution of anilin-blue for from 10–60 minutes, and then having been washed in distilled water are differentiated in absolute alcohol to a capsuleful of which 20–30 drops of 1 per cent. caustic potash-alcohol have been added. The latter solution is prepared by mixing 100 ccm. of absolute alcohol with 1 grm. of caustic potash, and allowing it to stand for 24 hours and then filtering.

The sections are next washed in distilled water for 5 minutes or so, after which they should be of a bright blue hue. They are then contrast-stained with a saturated aqueous solution of safranin diluted with an equal volume of distilled water. This takes from 15 to 30 minutes. They are next washed to dehydration in absolute alcohol, and then cleared up in origanum oil or xylol, and mounted in xylol balsam.

**Staining Crystalloids of Cell-nuclei.†**—Dr. A. Zimmermann finds that while nuclear crystalloids and nucleoli have very similar tinctorial relations, yet there are methods which allow of their being differentiated and, further, of showing that they belong to the erythrophilous constituents of the nucleus.

The material was fixed with alcoholic solution of sublimate, with absolute alcohol, or with Merkel's fixative (1 vol. 1 per cent. chromic acid, 1 vol. 1 per cent. platinum chloride, and 6 vols. water).

The preparations were then stained with: 1, acid fuchsin; 2, acid fuchsin-picric acid; 3, fuchsin-picric acid; 4, fuchsin-iodine-green (in this case the sections, after having been stained with a mixture of aqueous solutions of fuchsin and iodine-green, were placed in a solution of 100 ccm. alcohol, 1 ccm. acetic acid, and 0.1 grm. I, then in xylol, and afterwards mounted in balsam); 5, anilin-water-safranin (in this case, also, the sections were treated with the alcohol-acetic-acid-iodine mixture); 6, hæmatoxylin: the solutions used were those known as Mayer's hæmalum, Delafield's, Ehrlich's, Friedlaender's; 7, hæmatoxylin and ammonia-sulphate of iron  $(\text{NH}_4)_2\text{Fe}_2(\text{SO}_4)_4$ . When these last were used the solutions were first placed for 30 minutes to 3 hours in 2 per cent. iron solution, and then in an aqueous solution of pure hæmatoxylin for 1/2–12 hours (4 ccm. saturated alcoholic solution of hæmatoxylin, water 100 ccm.). The sections were then washed with water and once more treated with the iron solution, and having been washed in water were mounted in balsam. With this method the results vary with the method of fixation.

\* Centralbl. f. Allgem. Pathol. u. Pathol. Anat., iv. (1893) pp. 49–57 (1 colord. pl., 2 figs.).

† Zeitschr. f. wiss. Mikr., x. (1893) pp. 211–9.

**Fixing and Staining the Nuclei and Spores of Yeast.\***—Herr H. Moeller, after trying many fixatives for yeast preparations, such as 1 per cent. iodo-potassic iodide, absolute alcohol, boiling in amyl-alcohol, and boiling in glycerin, finds that boiling for 1 to 2 minutes in distilled water succeeds best. The author has given up gentian-violet and taken to Heidenhain's method, which consists in treating the fixed cover-glass preparations with ammonium ferric sulphate  $[(\text{NH}_4)_2\text{Fe}_2(\text{SO}_4)_4]$ . In a 3 or 4 per cent. solution of this ammonia-iron fluid the preparations are immersed for two hours at least. They are next washed in water and then stained for half an hour in a saturated aqueous solution of pure hæmatoxylin. After removal the preparations are again washed in water and then differentiated in the iron solution (1/2 to 2 minutes). This last procedure should be watched under the Microscope.

**Staining Spores.†**—Dr. P. Jaisohn recommends the following modification of Möller's method. After preparing a slide so that a drop of water spreads evenly on the surface, he gently passes a needle that has touched a recent culture a few times through the water. The slip must then be kept in a thermostat at 35° to 38° till the water is entirely evaporated; the slide is then passed three times through a flame, and placed in 5 per cent. chromic acid for two minutes, washed in water, and placed for three minutes in a solution of 3.5 grm. fuchsin, 35 ccm. absolute, 13 grm. phenol, and 230 ccm. water. After the superfluous stain is washed off, put in Loeffler's solution for two minutes; wash and mount. The bacteria will stain blue and the spores red.

**Selective Power of Cells in the Absorption of Pigments.‡**—Herr L. Lilienfeld states that nuclein acids derived from various sources take up the same pigment as the framework of the nucleus, while pure albuminoids behave in the same way as the cell-protoplasm. The nuclein-substances of the nucleus always take up the basic, while the albuminoids of the cell-body absorb the acid pigment out of a mixture. If a blue basic and a red acid pigment are mixed, the framework of the nucleus assumes a blue, the cell-protoplasm a red colour. The staining of nuclein-acids by basic pigments suggests the formation of a salt.

**Staining Tubercle Bacilli in Sublimate Solutions of Anilin Dyes.§**—Drs. Nastukow and Pewsner have devised the following method for staining tubercle bacilli. A 1 : 2000 solution of sublimate is mixed with anilin oil and then filtered. Of this 10 ccm. are mixed with 1 ccm. of a 10 per cent. alcoholic solution of gentian-violet, methyl-violet or fuchsin, and in this solution the preparations are immersed for five minutes. After having been washed in distilled water they are completely decolorized in dilute hydrochloric acid. The preparation may be contrast-stained in one per thousand solution of malachite-green, or one per two thousand of eosin in sublimate. Preparations thus stained need not be fixed in the flame, nor need the staining fluid be warmed.

\* Centralbl. f. Bakteriol. u. Parasitenk., xiv. (1893) pp. 358-60.

† Amer. Mon. Micr. Journ., xiv. (1893) pp. 321 and 2.

‡ Verhandl. Phys. Gesell. Berlin, 1893, No. 2. See Bot. Ztg., li. (1893) 2<sup>te</sup> Abtheil., p. 297.

§ Wratsch, 1893, No. 3. See Centralbl. f. Bakteriol. u. Parasitenk., xiv. (1893) p. 816.

**Simultaneous Double Stain for Leprosy and Tubercle Bacilli.\***—Dr. P. G. Unna describes a new method of staining leprosy and tubercle bacilli with polychrome methylen-blue, a pigment which must be obtained from Grübler. The method resulted from the observation that some sorts of methylen-blue contained methylen-red as well. By adding alkaline carbonates the red hue was found to be greatly improved, and it is well differentiated by acids, but still better by saturated aqueous tannin solution. The sections are stained for ten minutes to some hours in polychrome methylen-blue solution. On removal they are washed in water and then differentiated by immersion in 33 per cent. tannin solution. They are again washed in water and then dehydrated in absolute alcohol, cleared up in bergamot oil, and mounted in balsam.

After removal from the tannin solution, and having been carefully washed, the process may be varied as follows: immersion in spirituous gold-orange solution or 25 per cent. nitric acid; then dilute spirit, water, absolute alcohol, bergamot oil, balsam.

**Staining-differences of Male and Female Cells.†**—According to Dr. v. Raciborski, these differences, while well displayed in all higher plants, are wanting in many of the Coniferæ. This author has come to the conclusion that even in the higher plants there is no essential difference between the male and female nuclei, and that their staining phenomena present no argument against the theory of impregnation propounded by Hertwig, Strasburger, and Boveri.

(5) Mounting, including Slides, Preservative Fluids, &c.

**Preservative Fluid for Animals.‡**—M. Wiese (*sic*) is reported to recommend the following fluid for preserving the bodies of animals in their natural form and colours. 600 grm. of hyposulphite of soda are dissolved in 5 litres of water, and 75 grm. of chloride of ammonia in 250 grm. of water. The two solutions are mixed, and 4 to 6 litres of spirits of wine added.

**Formaldehyde for Hardening and Preserving.§**—Dr. F. Blum calls attention to the importance of formaldehyde (formol) as a reagent which does not affect the transparency of the tissues, does not precipitate mucin, often allows the natural colours to persist, and causes no shrinkage. He refers to his father's use of this fluid in preserving eyes,|| and criticizes a recent communication by Hermann.¶ Formol is a 40 per cent. solution of formaldehyde, and the hardening fluid is formal diluted ten times with water.

**Microscopical Preparations of Algæ.\*\***—M. A. Lemaire recommends the following process for permanent preparations of green algæ. Fix in a saturated solution of uranium acetate with 0.3 per cent. chrome-alum; leave for from 6–12 hours in the solution, and then wash thoroughly; place on the slide in 2 or 3 drops of a 10 per cent. solution of glycerin;

\* Monatshefte f. prakt. Dermatol., xvi. (1893) pp. 399–403.

† SB. Bot. Ver. München, Jan. 8, 1894. See Bot. Centralbl., lvii. (1894) p. 168.

‡ Rev. Scientif., 1893, p. 543. See Bull. Soc. Zool. France, xviii. (1893) pp. 211 and 2.

§ Anat. Anzeig., ix. (1894) pp. 229–31.

|| Zool. Anzeig., 1893, No. 434.

¶ Anat. Anzeig., ix. No. 4.

\*\* Journ. de Bot. (Morot), vii. (1893) pp. 434–40.



concentrate the glycerin under a bell-glass by means of calcium chloride ; and finally mount in Kaiser's glycerin-gelatin or Behrens' glycerinated ichthyocol.

**Cleaning Diatoms.\***—M. J. Tempère gives a variety of instructions for obtaining diatoms in a condition perfectly free from impurities, including the use of a "sieve-filter" made of silk.

Dr. P. Miquel † states that diatoms even of the length of 50–80  $\mu$  will pass through ordinary filter-paper ; and that Berzelius filter-paper is permeable to *Cyclotellæ* of 13–14  $\mu$  diam. Diatoms of which both the longitudinal and transverse dimensions are from 20–40  $\mu$  do not easily pass these filters, but are liable to be drawn up by capillary attraction.

(6) Miscellaneous.

**New Method of Separating the White from the Red Blood-corpuscles by means of the Hæmatokrit. ‡**—Dr. Judson Daland, in a

FIG. 24.

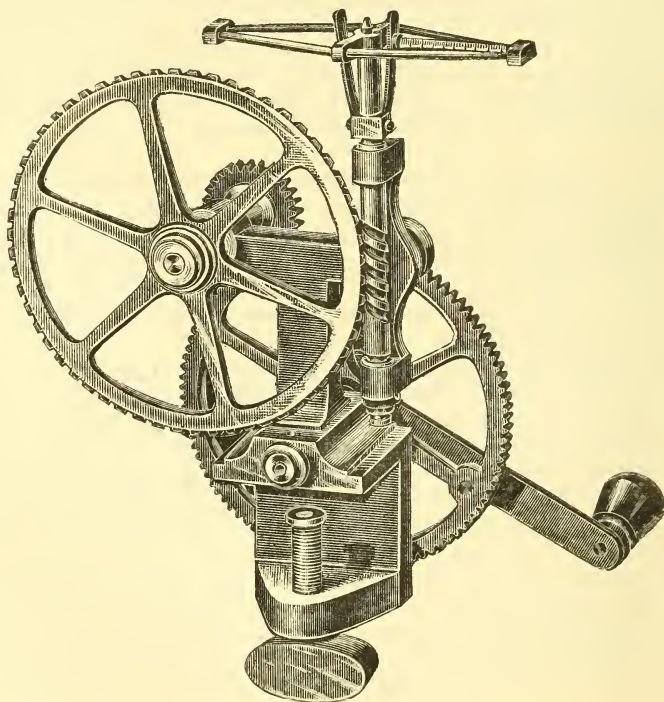

lecture delivered before the Franklin Institute, December 9, 1892, described a modification of the apparatus for separating the white from

\* *Le Diatomiste*, ii. (1893) pp. 21–6 (3 figs.). † *Tom. cit.*, pp. 26–9.

‡ *Journal of the Franklin Institute*, cxxxvi. (1893) pp. 204–14 (5 figs.).



the red blood-corpuscles which was first suggested in 1885 by Prof. Blix and later perfected by Dr. Hedin.

In Dr. Hedin's apparatus, represented in fig. 24, the glass tubes containing the blood are held securely by a spring in a brass frame at the top of an upright which is caused to revolve 104 times for one turn of the handle. In determining the volume of corpuscles the blood is mixed with an equal quantity of a fluid preventing coagulation and is then rotated, when the red corpuscles form a column at the periphery of the tube.

FIG. 25.

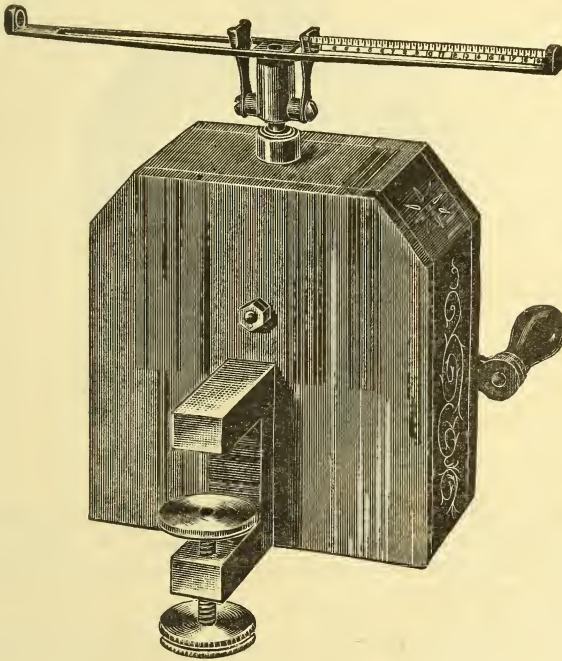

The author's improved hæmatokrit (see figs. 25 and 26) presents the following advantages:—The tubes are double the length of those used in Dr. Hedin's apparatus, viz. 70 mm., the lumen is reduced from 1 to 1/2 mm. in diameter, while the divisions on the scale outside the tubes are increased to 200, so that the percentage is at once determined. A series of experiments made by the author on nineteen different solutions led to the choice of a 2½ per cent. solution of bichromate of potassium as the most useful liquid with which to dilute the blood for counting red blood-corpuscles. When this diluting liquid was employed, 100 revolutions of the large wheel or 10,000 revolutions of the frame containing the tubes was found to be amply sufficient to secure a constant volume of red blood-corpuscles. Experiments made by the author upon twenty-five healthy men, with an average age of twenty-six years, in order to determine the normal volume and its

variations, showed that the percentage volume varied from 66 to 44, averaging 51.8. To determine the probable number of corpuscles for each percentage volume, the red blood-corpuscles in each case were carefully counted by means of the Thoma-Zeiss Hæmacytometer.

FIG. 26.

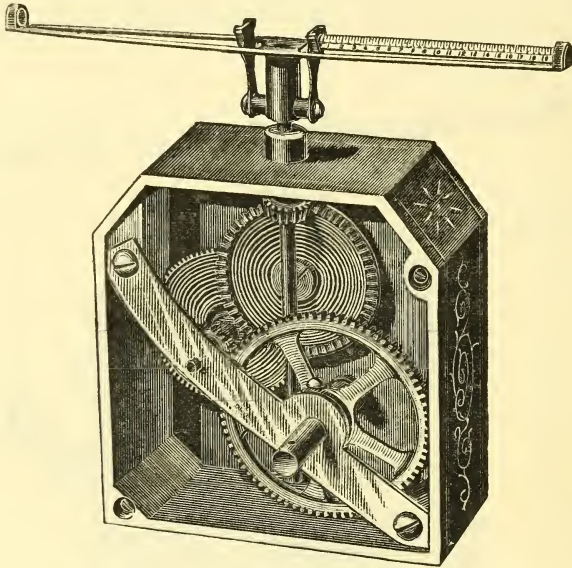

The average of all the counts was 5,088,442, so that 1 per cent. volume was the equivalent of 98,578 red blood-corpuscles. One percentage volume may therefore for convenience be considered as representing 100,000 red corpuscles.

From his various experiments the author deduces the opinion "that the hæmatokrit gives as accurate, if not more accurate, results than the Thoma-Zeiss apparatus as ordinarily employed, requires less skill, calls for no eye-strain, and the volume of red blood-corpuscles and number per cubic millimetre, and volume of white corpuscles, may be determined within ten minutes."

FIG. 27.

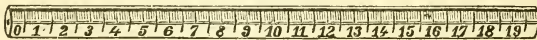

A table is added showing the variation in the volume of the blood-cells in a variety of diseases.

**Bacteriological Examination of Air.\***—Mr. J. E. Siebel made a bacteriological examination of air by passing it at about 40° through a

\* Mittheil. d. Zymotech. Inst. zu Chicago, ii. No. 9. See Centralbl. f. Bakteriologie u. Parasitenk., xiv. (1893) p. 140.

Mitscherlich's apparatus, which contained sterilized water. In this way it became saturated with moisture, and this, together with the contained germs, was deposited when the current was transmitted through a Liebig's tube kept quite cold. The deposit was collected and examined bacteriologically, and the quantity of air used was determined by means of an aspirator.

**Dithion, a New Antiseptic.\***—From his experience in veterinary practice Herr. L. Hoffmann finds that dithion has pretty strong antiseptic action. The medium appears to be useful in the treatment of wounds. A case of tetanus in a horse turned out favourably under the influence of large doses of this substance.

**Action of some Soziodol Preparations and of Tribromophenol-Bismuth on Cholera Bacilli.†**—Dr. A. Dräer finds from experiments that soziodol preparations, especially the mercurial and acid, have a powerful disinfecting property as regards cholera, while tribromophenol, even when used of twice the strength (4 per cent.) is not nearly so effective.

\* Repertorium d. Tierheilkunde, 1893, No. 1. See Centralbl. f. Bakteriol. u. Parasitenk., xiii. (1893) p. 634.

† Centralbl. f. Bakteriol. u. Parasitenk., xiv. (1893) p. 97.

## PROCEEDINGS OF THE SOCIETY.

MEETING OF 21ST FEBRUARY, 1894, AT 20 HANOVER SQUARE, W.  
THE PRESIDENT (A. D. MICHAEL, ESQ., F.L.S.) IN THE CHAIR.

The Minutes of the Annual Meeting of 17th January, 1894, were read and confirmed, and were signed by the President.

The List of Donations (exclusive of exchanges and reprints) received since the last meeting was submitted, and the thanks of the Society were given to the donors.

	From
Cobb, N. A., Nematodes, mostly Australian and Fijian ..	<i>The Author.</i>
Metcalf, M. M., Eyes and Subneural Gland of <i>Salpa</i> ..	<i>The Author.</i>
Manual de Técnica Micrográfica general. (Svo, Madrid, 1893) .. .. .	<i>Prof. Ramón y Cajal.</i>
Four Photomicrographs .. .. .	<i>Mr. J. B. Shearer.</i>
Congrès International de Zoologie. Pt. ii. .. .. .	<i>The Congress.</i>
Den Norske Nordhavs-Expedition. Pt. xxii. .. .. .	<i>The Commission for the Expedition.</i>
Report in Gynecology. Vol. iii. Nos. 7-9 .. .. .	<i>John Hopkins Hospital.</i>
Boston Society of Natural History—	
Proceedings. Vols. xiv.-xix., xxvi. } .. .. .	<i>The Society.</i>
Memoirs. Vols. i.-iii., iv. 4-11 }	
Bulletin from the Laboratories of Natural History of the State University of Iowa. Vol. ii. No. 4 .. .. .	<i>The University.</i>

Prof. F. Jeffrey Bell said that several of these donations were worth calling attention to as being of special interest to the Fellows of the Society. Mr. J. B. Shearer had written a letter saying that he read with great interest the Proceedings of the Society, especially with reference to photomicrography, and he had sent over four photomicrographs which he thought would perhaps be of interest. There was also a manual of practical micrography—the first work of the kind, he believed, which had been published in Spanish. The Spaniards had in times gone by distinguished themselves in matters of geographical discovery, but they had not hitherto been known very much in connection with histology. Part 22 of the Report of the Norwegian North Sea expedition had also been sent to them; the illustrations in the preceding numbers were specially remarkable for their excellence, and no higher praise could be given to those in the present part than to say that they were in all respects equal to those which had previously appeared. Some time ago the Boston Society of Natural History pointed out that their set of the Journal of the Royal Microscopical Society was not complete, and in responding to their request for such numbers as were deficient, it had been mentioned that there were similar deficiencies in the Society's series of the Proceedings and Transactions of the Boston Society. The result was the large pile of numbers upon the table, which had been forwarded in order to make the sets complete. These would prove a valuable addition to the Library.

The President thought the photographs from Mr. Shearer were most



beautifully done, and the mode of noting at the bottom all the particulars as to the power employed—the exposure and other matters—was an extremely good one. He proposed that special thanks should be given for these and also for the number of parts sent to complete their sets of the Boston Natural History Society's publications.

This was put to the Meeting and carried unanimously.

Mr. T. Charters White said he had looked at the photographs with a critical eye and thought they were the sharpest of the kind which he had seen for many years. Most of those shown in that room seemed to have been taken with too high powers and were consequently more or less blurred. These now exhibited were taken with a low power,  $\times 25$ , and therefore they would bear enlargement without detriment.

Mr. E. M. Nelson did not see anything specially excellent about these as photomicrographs, they were very simple objects taken with low powers with an ordinary camera lens and a gas-lamp.

The President thought, with all deference to Mr. Nelson, that though these were, as he said, low-power objects, they were extremely fine specimens, and showed a large amount of useful detail for ordinary purposes.

Mr. White said these would of course hardly rank with some higher power objects, of which he exhibited a specimen taken with an oil-lamp and power of  $\times 156$ . The object was rather a favourite one of his—the developing tooth of a foetal kitten.

Mr. Nelson said that on inspection it was clear that this was quite a different class of thing.

---

The President said he might mention that he had received from Dr. Trouessart of Paris a single slide by post, in a kind of box which was new to him. It struck him as being extremely simple in construction, just a deep groove planed out of a strip of wood and another piece made to fit over it, so that they could be made in lengths and cut up to take the slides. And in addition to being cheap they were much more solid and therefore less liable to get crushed in the post.

Mr. G. C. Karop said it was rather curious that he had himself received a box of the same kind a few days previously containing three slides, but unfortunately every one of them was broken badly in the transit.

---

The President said they had a paper that evening by Prof. G. S. Brady, F.R.S., "On *Fucitrogus Rhodymenizæ*, a Gall-producing Copepod." It was hoped that Prof. Brady would have been present and would have read his paper to them, but he had been prevented from coming.

Prof. Bell then, at the President's request, gave a *resumé* of the contents of the paper.

The President said this form was one of great interest to the naturalist, and when a description of it came from a gentleman so well acquainted with the group as Prof. Brady it became doubly interesting. This struck him as being a most exceptional and remarkable form, and therefore as one of extreme interest. So far as he knew it was entirely unprecedented, and the fact that a copepod should be a gall-making creature was, to say the least, very extraordinary.

Prof. Bell said there was no group which entertained so many bizarre creatures or presented such anomalous forms as the one which formed the subject of Dr. Brady's communication. It was hoped that when the paper was published the attention of other naturalists would be drawn to the subject, and that those who met with specimens would forward them to Dr. Brady for examination. It was clear that the specimen before him was not a complete one, the digestive tract was broken and it was therefore very desirable that they should have further and more perfect examples for the purpose of completing the observations.

Upon the motion of the President the thanks of the Society were given to Prof. Brady for his paper, great regret being at the same time expressed that the author had been unable to be present.

---

The President announced that arrangements had been made for holding a *Conversazione* on April 4th at St. Martin's Town Hall.

---

The following Instruments, Objects, &c., were exhibited:—

The Society:—Mr. J. B. Shearer's Photomicrographs.

Mr. T. Charters White:—Photomicrograph of Section of Tooth of Foetal Kitten.

The President:—New Form of Postal Slide-box.

---

New Fellows:—The following were elected *Ordinary* Fellows:—The Hon. Sir Ford North, and Messrs. Samuel Robert Brewerton and Thomas Mansell. *Honorary* Fellow:—Prof. Edouard Van Beneden, of Liège.

---

MEETING OF 21ST MARCH, 1894, AT 20 HANOVER SQUARE, W.

THE PRESIDENT (A. D. MICHAEL, ESQ., F.L.S.) IN THE CHAIR.

The Minutes of the Meeting of 21st February last were read and confirmed, and were signed by the President.

---

The President said it was with great regret that he had to announce to the Society the loss they had suffered by the sudden death of Mr. C. Haughton Gill, one of the Members of their Council. Mr. Gill had recently retired from active business, and it was hoped that with additional leisure at his disposal he would have been able to follow up those lines of inquiry which—from the communications he had made to the Society—seemed to promise so much. This hope had, however, been frustrated, and he was sure it would be felt by all that they had lost one who was not only a pleasant companion, but also a useful Member of the Council of the Society.

---

Prof. F. Jeffrey Bell read a letter received from Prof. Edouard Van Beneden expressing his thanks for his election as an *Honorary* Fellow of the Society, in place of his late father.

The List of Donations (exclusive of exchanges and reprints) received since the last meeting was submitted, and the thanks of the Society were given to the donors.

	From
Monograph of the Palæontographical Society. Vol. xlvii. ..	} <i>Mr. Frank Crisp.</i>
Proceedings of the Royal Institution of Great Britain. Vol. xiv. pt. 1 .. .. .	
Memoirs of the Californian Academy of Sciences. Vol. ii. No. 3 .. .. .	} <i>The Academy.</i>
Crombie, J. M., Monograph of British Lichens. Vol. i. ..	} <i>The Trustees of the British Museum.</i>
A Stereoscopic Photomicrograph of <i>Heliopelta</i> .. .. .	} <i>Dr. W. C. Borden</i>

Prof. Bell called special attention to the volume presented by the Trustees of the British Museum as being the first descriptive catalogue issued by the Botanical Department.

On the motion of the President, the special thanks of the Society were voted to the Trustees of the Museum and to Mr. Frank Crisp for their valuable donations.

Mr. C. L. Curties exhibited and described a new form of photographic camera and apparatus for drawing microscopic objects designed by Prof. Edinger, and sent over for exhibition by Herr Leitz, of Wetzlar. Mr. Curties said that he had taken some photographs with it, and found it to work well; for drawing, the camera was removed and the image of the object was projected distinctly upon a sheet of paper placed upon the base-board.

Dr. W. H. Dallinger said he had not used this apparatus for photography, but he had for drawing, up to about 120 diameters, and found that it worked extremely well; for this purpose he thought it would be far more useful than anything of the kind which he had yet met with, especially where it was desired to draw large objects rapidly. Mr. Curties appeared also to have found it useful for photography—of course, for low powers only—and therefore it was likely to prove doubly useful.

Dr. Dallinger exhibited a new pattern Microscope recently made by Mr. Swift, which was, perhaps, not remarkable in any special way, save one. He had long striven to get an inexpensive instrument of thoroughly good quality suitable for histological work, so that the student need not go to Germany to get his Microscope. One of the conditions laid down was that it should have a tripod stand, as affording a firmer basis than the heavy horse-shoe foot. In practice, however, he had found that most of the inexpensive instruments made on this plan would tilt comparatively easily at right angles to the sides of the triangle. Mr. Swift had now adopted a plan by which in a method which was most ingenious he had succeeded in getting over this difficulty. It was obvious that if they added a fourth foot, the freedom from lateral tilt would be secured, but this, as they also well knew, would be at the risk of destroying the general steadiness whenever the instrument was placed upon a surface not perfectly even. Mr. Swift had, however, got over this by making a four-footed instrument which—paradoxical as it might sound—was still in reality

a tripod. It would be seen that this was achieved by making the back leg double, and as this was pivoted to the body and capable of considerable lateral movement, it readily adapted itself to any surface on which it might be placed, and secured at the same time all the advantages of a non-tilting four-footed instrument, with the stability of the tripod. The instrument was fitted also with a sliding bar, a horse-shoe opening to the stage, a very well arranged substage which would take an Abbe condenser, and a coarse- and fine-adjustment with differential screw, and it could be supplied at so low a price as to come within the means of any English student. He was very glad to see such an instrument in the English market.

The President thought this was very likely to prove a very useful instrument; it was certainly superior in point of steadiness to anything of the kind yet produced. His only doubt about it was whether, in spite of the strong spring fitted to the joint of the back leg, it might not at some time or other work loose.

---

Messrs. Watson and Sons exhibited a new superstage-plate which was fitted with two steel springs which pressed against the upper plate. It was intended to be fitted to the top stage-plate of an ordinary Microscope. They also showed a Ramsden's screw micrometer made of aluminium, resulting in a reduction in weight from 11 oz. to 5 oz.; and an Abbe camera lucida, also in aluminium, in which the weight had been diminished in similar proportions.

The President said this was not the first time that Mr. Watson had taken advantage of the superior lightness of aluminium, and it would be readily understood how great the advantage was in the present instances, of relieving the eye-piece from the weight of the apparatus placed upon it.

---

Mr. R. T. Lewis said he had brought for exhibition two slides recently sent to him by Mr. Arnold W. Cooper, of Natal (elected a Fellow of the Society at their meeting in January last) which he thought would be of some interest. The objects were the larval and perfect forms of a kind of scale insect which appeared to be doing some mischief to lemon-trees in the colony. He had been able to identify it as being one of the *Psyllidæ*, a family of Homopterous Insects occupying a place between the Coccididæ and the Aphides, and it appeared to be identical with *Trioza pellucida*, a species originally found and described by Mr. Maskell in the Transactions of the New Zealand Institute in 1878. Its appearance in Natal was worth noting, as possibly another instance of importation. Mr. Cooper was intending to establish a vivarium, in which it was hoped he might be able to trace out the life-history of many similar creatures with equal success.

---

Dr. Dallinger said that the following letter had been received from Dr. H. G. Piffard, of New York, but as he did not state if the condenser he used was chromatic or achromatic, it was very difficult to come to any conclusion as to the results which he seemed to have arrived at.

"I have recently ascertained that several of Powell and Lealand's water-immersion lenses belonging to their series of N.A. 1.26 will



correct not only with oil, but also with monobromide of naphthaline. To neutralize the over-correction introduced by the monobromide it was necessary to close the systems and shorten the tube to about 155 mm. to 160 mm. The result is an increase of aperture to N.A. 1.56 with manifest improvement of the image, and incidentally also a partial obliteration of the secondary spectrum.

I have further found that a number of American oil-immersions will behave in a similar manner.

To obtain the best results, it is important to provide efficient substage illumination. For this purpose I have at command nothing better than an Abbe, making either oil or monobromide contact with the slide. Doubtless a P. and L. achromatic N.A. 1.40 would be much better."

---

Mr. J. G. Grenfell exhibited and described specimens of the Dicyemida, which are parasites on the renal organs of *Octopus sepiæ* and other Cephalopods. Their structure is very remarkable, as they consist of a long central cell, in which the complicated reproductive processes take place, and a few nucleated cells loosely attached to this. There is thus no central body-cavity. Hence their discoverer, E. van Beneden, who has just been made an honorary Fellow of the Society, claimed for them a position on a par with the Protozoa and Metazoa, calling them the Mesozoa. But they are generally regarded as Metazoa altered and degraded by parasitism. They are not to be found in our museums or private collections, and very few persons have ever seen them. One of the principal reasons for this, apart from the difficulty of getting live Cephalopods, is the fact that when killed by the ordinary reagents they break up into their constituent cells. He had, however, succeeded in getting over this difficulty by hanging bits of the kidney by threads beneath the surface of sea-water in a tumbler, and then adding enough chromic acid solution to give a very pale colour. Under these circumstances the Dicyemida left their hold on the kidney and fell to the bottom without disintegration, and died there. They could then be transferred to the ordinary preservative reagents. The method has the further advantage of obtaining the specimens free, or nearly so, from the mass of disintegrated kidney-cells which always accompany the Dicyemida when a bit of kidney is teased on a slide.

Mr. Grenfell illustrated the subject by drawings upon the board.

The President said this creature was certainly a very remarkable one. The communication had been very clearly put, and had been a most interesting one.

---

Mr. T. C. White having taken the chair,

The President read a paper on the *Uropodinæ*, which he explained might be considered as in continuation of some papers read in 1889 and 1890, on the Anatomy of the *Oribatidæ*. He had then purposed doing the same thing in regard to the *Gamasinæ*, but had been struck with the anatomy of these *Uropodinæ*, and had given some attention to them.

Mr. T. C. White said they knew very well that whatever their President touched was sure to be dealt with most lucidly, and his com-

munication to them that evening had been no exception. Personally, he was only sorry that they had not taken up this branch of Natural History after the example shown, so that they might have been better able to support him, and to enter into the subject more thoroughly for themselves, as a result of the interest which had been excited by the descriptions which the President had from time to time given them in a manner not easily to be excelled.

The thanks of the meeting were, upon the motion of the Chairman, unanimously voted to the President for his valuable communication.

---

Prof. Bell reminded the Fellows of the Society of the *Conversazione* arranged for April 4th, and expressed a hope that as many as possible would send in their names as exhibitors at once—the responses up to that evening not having been so numerous as they had expected.

---

The following Instruments, Objects, &c., were exhibited:—

The President:—Specimens illustrating his paper.

The Society:—Dr. W. C. Borden's Stereoscopic Photomicrograph of *Heliopelta*.

Mr. C. Lees Curties:—Edinger's Drawing and Photomicrographic Apparatus.

Dr. W. H. Dallinger:—A new Model Microscope by Messrs. Swift.

Mr. J. G. Grenfell:—Specimens of *Dicyemida*.

Mr. R. T. Lewis:—Larva and Imago of *Trioza pellucida*, from Mr. A. W. Cooper, of Natal.

Messrs. Watson and Sons:—New Stage-plate, Ramsden Screw Micrometer and Abbe Camera Lucida in Aluminium.

---

New Fellows:—The following were elected *Ordinary* Fellows:—  
Mr. Thomas Daniel Ersser, Dr. John Macintyre.

---

JOURNAL JUL 6 1894  
 OF THE  
 ROYAL MICROSCOPICAL SOCIETY.  
 JUNE 1894.

TRANSACTIONS OF THE SOCIETY.

VI.—Notes on the Uropodinae.

By A. D. MICHAEL, P.R.M.S., F.L.S., F.Z.S., &c.

(Read 21st March, 1894.)

PLATES VI. AND VII.

THIS paper must be considered a continuation of my memoirs in this Journal in the years 1889 and 1890. Those papers dealt entirely with the anatomy; I intended to follow them by some observations on the classification, and by a list of such British species as I or others

EXPLANATION OF PLATES.

PLATE VI.

- Fig. 1.—*Glyphopsis Bostocki* (p. 301) sp. n., ♂; dorsal surface. × 38.  
 " 2. " " ♀; ventral surface. × 25.  
 " 3. " " ♂ three proximal joints (coxa, &c.) of first left leg seen from below. × 120.  
 " 4. " " ♂ genital opening. × 38 (placed between the coxae of the third pair of legs).  
 " 5.—*Uropoda hamulifera* (p. 298) sp. n., ♂; dorsal surface. × 70.  
 " 6. " " ♀; ventral surface. × 50.  
 " 7. " " some of the dorsal hairs; *a*, from the side; *b*, from above; *c*, from below. × 350.  
 " 8.—*Cylliba (Discopoma) pandata* (p. 300) sp. n., ♀; dorsal surface. × 90.  
 " 9. " " ♀; ventral surface. × 90.

PLATE VII.

*Glyphopsis formicariæ* Lubbock (p. 310).

- Fig. 1.—Dorsal surface of ♀. × 60.  
 " 2.—Ventral " "  
 " 3.—The two distal joints, and part of the proximal joint, of the mandible of the ♂, × 350. *a*, levator, *b*, depressor muscle of the movable arm of the chela with their respective tendons. *c*, chitinous block in the course of the tendon, forming a fulcrum.  
 " 4.—Hypostome from below, × 350. *li*, lingua. *gal*, galea (of Mégnin). *st*, stylus.  
 " 5.—Palpus from the side. × 170.  
 " 6.—One of the pair of median spines from the under-side of the oral tube. × 700.

had been able to observe, as there is absolutely no existing record of which are British species. I have not hitherto had time to accomplish this, but I now do so; I have also endeavoured to elucidate the synonymy, which, in my opinion, is greatly in want of it; and I have described some of the principal new species in my possession. I really have several others; but to properly illustrate them all would require more plates than can be allotted to this paper. I have also made some further observations on the anatomy of one species.

The Uropodinæ are a well-marked sub-family of the Gamasidæ; Berlese in his late work, hereinafter referred to, distinguishes them from other Gamasidæ by the genital plate of the female being wholly surrounded by the sternal plate; this does not seem to me to be a good means of differentiating them. The genital plate is in the same position as in most other Gamasidæ; if the sternal plate has the appearance of surrounding it it is only because in most Uropodinæ all the ventral plates except the genital which is required to be movable, are fused; and it is impossible to say where one ends and the other commences. Moreover, the genital plate is partly surrounded by the sternal in many other Gamasidæ.

To me the essential characters of the Uropodinæ seem to be, first, that the camerostoma (camerostrum) or opening for the passage of the oral tube (in effect the rostrum) is in the ventral surface, and that the dorsal surface projects beyond it, so that it is hidden on the under-side of the creature; whereas the oral tube when exerted forms an anterior continuation of the body in other Gamasidæ. Second, that the first pair of legs are inserted actually within the same opening as the oral tube instead of at the side of it. To these principal characters should be added that the Uropodinæ are possessed of very long and slender mandibles, with small and fine chelæ, similar in the two sexes; and that the genital opening of the male is within

PLATE VII. (continued).

- Fig. 7.—Alimentary canal, &c., ♀, × 85. *æ*, œsophagus. *br*, brain. *v*, ventriculus. *cæ*, *cæ*, larger cæca of the ventriculus. *c*, colon. *r*, rectum. *mv*, Malpighian vessels.
- „ 8.—Genital organs of the male, × 85. *cr*, chitinous ring with supporting pieces. *ga*, genital aperture. *de*, ductus ejaculatorius. *vs*, central chamber or vestibule (vesicula seminalis?). *t*, *t*, testes. *ag*, accessory gland. *gl*, oil-glands.
- „ 9.—Epigynium (external genital plate of ♀) seen from within, × 85. *mp*, membranous portion.
- „ 10.—Perigynium (inner membranous genital plate of ♀) seen from below, × 170. The spines are seen through the membrane.
- „ 11.—Coxa, &c., of the second leg, with the coxal gland and duct *in situ*. × 85.
- „ 12.—Coxal gland and duct seen on edge. × 170.
- „ 13.—One of the two largest racemose glands. × 350.
- „ 14.—One of the expulsive vesicles. × 350.
- „ 15.—Peritreme, × 175. 2, excavation for second leg. 3, ditto for third leg. *r*, ridge between the two. *p*, peritreme.



the sternal plate instead of at its edge or anterior to it. This last character is, however, shared by some genera of Gamasinæ.

We do not at present know for certain what the Uropodinæ feed upon. They are chiefly sluggish creatures, slow in their movements and not moving much. They are frequently solitary, inhabiting moss, old wood, &c., or hiding under stones; many species, however, such as *Uropoda Krameri*, *U. ovalis*, &c., are often found in great numbers together in old barns and hay-lofts, hot-beds, &c. A considerable number of the species inhabit ants' nests, and live on friendly terms with the ants.

#### THE PRINCIPAL BIBLIOGRAPHY RELATIVE TO THE UROPODINÆ.

De Geer was the first observer of any of the *Uropoda*. In his well-known work\* he describes what he calls *Acarus vegetans*; this was doubtless an immature creature, and de Geer probably did not distinguish between the nymphs of several species.

Latreille, in 1806,† instituted the genus *Uropoda* for de Geer's *Acarus vegetans*, correctly making it a genus of Gamasidæ.

Hermann, in 1804, had described another species (*cassideus*) which really should have been of the same genus of Gamasidæ as *vegetans*,‡ but Hermann did not recognize this; he was deceived by its appearance, and included it in his genus *Notaspis*, a genus which did not apply to *Gamasidæ* at all, but was really synonymous with Latreille's *Oribata*. Some little confusion has arisen from this, as some modern authors have adopted Hermann's name instead of Latreille's, relying probably on the order of date, but forgetting that Hermann's numerous *Notaspides* were not Gamasids, and that this species was only included by mistake. This use of the term *Notaspis* has, I believe, now been generally abandoned. In 1826 von Heyden proposed the genus *Cilliba* for Hermann's *cassideus*.§

Of late years several attempts have been made to divide the *Uropodinæ* into genera. These are noticed further on.

In addition to the works above referred to, the following are

\* 'Mémoires pour servir à l'histoire des Insectes,' Stockholm, 1778, t. vii. p. 123, pl. vii. figs. 15-19.

† 'Genera Crustac. et Insec.,' Paris, 1806, genus 62, t. i. p. 157.

‡ 'Mémoire aptérologique,' Strasbourg, 1804.

§ 'Versuch einer systematischen Eintheilung der Acariden,' Oken's Isis, Bd. 10, p. 613. This paper is difficult to obtain, and consequently is generally known from Gervais' imperfect summary of it, which contains several mistakes. Gervais gives the genus as *Cillibano*, which has been often quoted; but it is an error; the original is *Cilliba*; Agassiz has it correctly. Agassiz says the name is derived from *κίλλος*, a Doric word for an ass. I doubt if this can be the direct and sole derivation; I should think it is derived from *κίλλιβας* or *κίλλιβαντες*, the props on which the Greek soldiers, when tired, supported their shields; the form of the shield on its props would resemble that of the *Acarus*. Of course *Cilliba* would be a contraction, possibly not very correctly made. Probably the better word would have been *Cillibas*. Of course the word *κίλλιβαντες* is probably derived from *κίλλος* and *βαω* (*βαινω*), to go, or cause to go.

the principal authorities for the identification and organization of Uropodinæ.

- KOCH, C. L.—'Deutschlands Crustaceen, Miriapoden und Arachniden.' Regensburg, 1835–41. This work describes several species, but Koch's species are often difficult to identify, and often based on immature forms, &c.
- MÉGNIN, P.—"Mémoire sur l'organisation et la distribution zoologique des Acariens de la famille des Gamasidés." Journ. de l'Anat. et de la Physiol. (Robin), May 1876, pp. 288–336. This valuable work refers chiefly to anatomy, &c., but is of little use in identifying species.
- KRAMER, P.—"Zur Naturgeschichte einiger Gattungen aus der Familie der Gamasiden." Archiv für Naturges., 1876, pp. 47–105.—"Ueber Gamasiden." Op. cit., 1882, p. 374.
- HALLER, G.—"Acarinologisches" (second paper of that name). Archiv für Naturges., 1881, p. 182.
- CANESTRINI, G., & F. FANZAGO—"Intorno agli Acari italiani." Atti del R. Ist. Veneto di Sci. Let. ed Arti, 1877.
- CANESTRINI, G.—"Acari nuovi o poco noti." Op. cit., 1884.—"Prospetto dell' Acarofauna italiana." Padua, 1885.
- CANESTRINI, G., & A. BERLESE—"Sopra alcune nuove specie di Acari italiani." Atti della Soc. Veneto-Trentina di Sci. Nat., 1884.
- BERLESE, A.—"Acari, Miriapodi e Scorpioni italiani," Padua, Florence and Naples, commenced 1882, still publishing, but Gamasidæ, including Uropodinæ, apparently finished.—"Acari Austro-Americani quos collegit Aloysius Balzan." Bull. Soc. Entom. Ital., 1888.
- THORELL, T.—"Descrizione di alcuni Arachnidi inferiori dell' Archipelago Malese." Ann. del Mus. Civ. di St. Nat. di Genova, February 1882, vol. xviii. p. 21. It is doubtful whether the species here described are really Uropodinæ.
- WINKLER, W.—"Anatomic der Gamasiden." Arbeiten Zool. Inst. Univers. Wien, 1888, Bd. vii. Heft iii. p. 318.
- MICHAEL, A. D.—"Observations on the Special Internal Anatomy of *Uropoda Kramerii*." This Journal, 1889, p. 1.—"On the Variations of the Female Reproductive Organs, especially the Vestibule, in different Species of *Uropoda*." Op. cit., 1890, p. 142.—"On the Association of Gamasids with Ants." Proc. Zool. Soc. Lond., December 1st, 1891, p. 638.

#### CLASSIFICATION OF THE UROPODINÆ.

Until the year 1876 the Uropodinæ consisted of the single genus *Uropoda*; because Koch's proposed genus *Celæno* was a genus of Oribatidæ, not of Gamasidæ; although one species of the latter family (*ægrota*) was placed in it by mistake; but in that year Kramer instituted the genus *Trachynotus* for a species (*pyriformis*) which he subsequently identified, I think erroneously, with the very species which Koch had placed by mistake among the Oribatidæ. Unfortunately Kramer's name cannot be sustained, because it had been used

previously by Latreille, in 1829, for a genus of Coleoptera, also by Gravenhorst in the same year (1829) for a genus of Hymenoptera, also by Bell in 1862 for a genus of Crustaceans; and *Trachinotus* had been used by Lacépède and subsequently by Cuvier in 1817 for a genus of fishes, besides the frequent use of *Nototrachus*, &c. Although Kramer's name cannot be maintained, his creature may well be the type of a separate genus, and the distinction upon which he founded it, viz. that the excavations in the ventral plate for the reception and protection of the legs when folded, which exist in most other Uropodinæ, are absent in this genus, ought to be, and is preserved; although later discoveries have shown that the species without excavations require more than one genus. The genus *Dinychus* was added by Kramer in 1886; the other existing genera have been all added either by Canestrini, Berlese, or Thorell. The table of the second author, at p. 87 of his 'Ordo Mesostigmata,' published in 1892, is practically the only general classification including all the genera up to this time (it will be seen that they are few in number); it also, of course, shows Prof. Berlese's views on the subject of the classification; it will be most convenient to discuss the classification from this standpoint. The following is a translation of his table:—

With excavations for reception of legs.	{	First pair of legs with ambulacra (claws and caruncle) .. .. .	<i>Uropoda.</i>						
		"    "    without ambulacra .. .. .	<i>Discopoma.</i>						
Without such excavations.	{	Body of adult and nymph protected by a fused dorsal and ventral plate .. .. .	<i>Dinychus.</i>						
			Plates disappearing in adult, or body protected by numerous plates, dorsal and ventral .. .. .	{	Plates, especially the ventral, disappearing in the adult; margins of all except the genital plate obsolete .. .. .	<i>Uroseius.</i>			
		Dorsal and ventral plates conspicuous .. .. .				{	Genital plates well marked and distinct from the sternal .. .. .	{	First legs with ambulacra ..
					First legs without ambulacra				<i>Polyaspis.</i>
		Genital plate of the female fused with the sternal plate .. .. .	<i>Uropodella.</i>						

It will be seen that Berlese's first general division of the Uropodinæ is that adopted by Kramer to distinguish his genus *Trachynotus*; as stated above, I think that this method of differentiation should be utilized, and I have adopted it. Berlese, following Canestrini, next divides the creatures having excavations according to whether they have or have not ambulacra (i. e. claws and caruncles) to the first leg. I regret to say that I cannot agree that this is a

good method of dividing; it may be preserved to differentiate smaller groups, but it seems to me very artificial and to divide the species into very unnatural genera. In considering the importance of the character it must be remembered that the ambulacra are not functional in any of the creatures; the first pair of legs in all of them have entirely ceased to be walking organs; they are solely tactile (possibly also auditory), and are not ever used for walking. The same is true also of many other Gamasidæ, and as a result the ambulacra are often so vestigial as to be almost obsolete; and it is sometimes very difficult to say whether a species should be said to possess ambulacra or not; small chitinous fixed projections sometimes take the place of the claws, and the distinction between one and the other is not always clear. With regard to the naturalness of the groups created by this mode of division, it seems to me that they are not happy; for instance, Canestrini's genus *Discopoma*, which consists of creatures without ambulacra, contains very few species at present recorded, but amongst them are Kramer's *splendida* and Berlese's *venusta*, Acari far more closely allied to *Uropoda carinata*, *U. Berlesiana*, *U. lamellosa*, &c., than to *cassidea* and *romana*, which form the remainder of the genus *Discopoma*; while the two last-named species are very similar in all respects, except the absence of ambulacra, to such species as *Uropoda Ricasoliana*, *U. vegetans*, *U. tecta*, &c.

It seems to me that the only distinction which will divide the Uropodinæ with excavations for the legs into two really natural groups of closely-allied creatures is that between the species regular in form and with dorsal shields smooth, or simply pitted or areolated, and those of irregular form with dorsal shields sculptured. I admit that this does not sound very well on paper, but I do not think that any one who will take the trouble to arrange the creatures themselves into the two series by this rule will doubt that those in each group are closely related, and differ considerably from those in the other group; if they will take the trouble to dissect them, this will become still more apparent. The mode of differentiation may not be quite as sharp and easy as a purely artificial distinction, but then a natural arrangement seldom is. The first group, of regular form, contains creatures mostly oval or round in form, with the dorsum regularly domed or arched, becoming quite thin at the periphery, and the dorsal and ventral plates quite distinct. Those of irregular form vary greatly in shape; the dorsum is sculptured, mostly in a rough and irregular manner; it is not regularly domed or arched; seldom becomes thin at the edges, often indeed becoming thicker; and the dorsal and ventral plates are generally so much fused that it is difficult to distinguish the demarcation between them. It is necessary to find a name for the genus to consist of the irregular-shaped species; Kramer's name of "*Trachynotus*," had it been available, would have been an appropriate one; but, unluckily, that and every other really suitable name expressing exactly what I wish appears to be pre-



occupied. The best available name which I have been able to hit upon is *Glyphopsis*,\* and that name I propose to adopt. I believe it has not yet been used.†

"*Uropoda*" must, of course, be retained for the typical genus, on the type of De Geer's *vegetans*; this will include the larger part of the Uropodinæ. As Canestrini and Berlese have thought it best to separate those without ambulacra, and I wish to adhere to their classifications as far as I can, I have divided off the species in that condition from *Uropoda*; although I scarcely think that I should have originated the distinction, and I have not thought it necessary to introduce it into the rough and irregular (sculptured) group.

*Discopoma* is the name which Canestrini and Berlese have employed; it is a very good name, and I should be glad to retain it. I rather doubt, however, if it be possible to do so. The position is this. The type of the genus must be considered to be Hermann's *cassidea*. That is the species which Berlese figures in the adult stage to illustrate his description of the genus,‡ and the name itself shows that it was the species which Canestrini very properly based the genus upon; but in 1826 C. von Heyden (loc. cit.) published a classification of the *Acarina*, which has been a difficulty in the way of acarologists ever since; in that classification he found a new genus, "*Cilliba*," expressly on the type of *cassidea*, and makes the absence of claws on the front legs the distinctive character; it is not intended to be instead of *Uropoda* because von Heyden gives *Uropoda* also, and it cannot be suggested that *cassidea* differs from other species of *Uropoda*, except in the absence of ambulacra on the front legs. Heyden states erroneously that the other legs have tridactyle claws; they really are didactyle.

In reply to my inquiry, Prof. Berlese was kind enough to inform me that he had not used the earlier name of "*Cilliba*" because he and Canestrini had agreed some time since that Heyden's work was so imperfect that it would be better to disregard it altogether. I fully agree that it would be better and much more convenient to do so, if possible. Heyden's was the mere sketch of a classification of which the fuller details were intended to appear later, but they never did appear. It creates forty-eight new genera; most of them are based upon entirely incorrect anatomy, often morphological characters which do not exist in any of the *Acarina*, and which it would be impossible to retain. In far the greater number of new genera the type given is a species of his own (so stated), but the species, as far as I know, were never described; doubtless Heyden intended to describe them, but did not, and we cannot be sure even what families they belonged to. In about a quarter of the new genera, however, a well-

\* γλυφή, a sculpture, and οψίς, appearance.

† The term *Trachyuropoda* used by Berlese (*Acari* Austro-Amer., p. 39, note) seems to be descriptive, not classificatory. It would not suit my purpose, as it does not include such forms as *splendida*.

‡ *Acari*, &c., Ital., fasc. 68, No. 7.

known type-species, described by other authors, is given. Many of these genera fail, as for instance "*Galumna*" for *Notaspis alatus* of Hermann, which is considered the type of the genus *Oribata*, which is earlier than Heyden's time, and *Spinturnia*, which was equivalent to Dufour's earlier genus *Pteroptus*; *Cunaxa*, which is equivalent to Hermann's older genus *Scirus*, &c. In some cases acarologists have not considered that any new genus is required; but the question is, are we at liberty to disregard Heyden's name in the few cases where it is considered that a genus is required distinctly based on the very type, and that a well-known one, which Heyden gives and on his generic characters? With regard to this question, it must be remembered that Heyden's genus "*Myobia*," for Schrank's *Pediculus musculi*, has been universally adopted. Berlese's view, I believe, is that this is because Claparède used it; but Claparède only employed it on account of Heyden's earlier publication. Again, Berlese and Canestrini, the former as lately as 1892, employ Heyden's genus "*Belba*" instead of Koch's "*Damæus*"; and Berlese in his description of the genus expressly refers it to Heyden. It is true that I do not think that the genus *Belba* can be maintained, because it was founded on Hermann's *Notaspis corynopus* as a type; and that Acarid is not a *Damæus*, but a *Notaspis* (an earlier genus), even in the restricted sense in which that name is now employed; therefore Trouessart, very properly, I think, uses *Damæus*, and not *Belba*. The anatomy on which *Belba* is founded is utterly wrong; it is "Head, prothorax (sic), and metathorax separate." This in the Acarina does not need any comment; Heyden was perhaps partly deceived by Hermann's drawing. On the other hand, Berlese, Canestrini, and Trouessart adopt Koch's name of "*Ammonia*" instead of Heyden's earlier name of *Cyta* for *Scirus latirostris* Hermann, which is unfortunate, because *Ammonia* had been used long before Koch's time, for a genus of Mollusca, whereas *Cyta* had not to my knowledge been previously used. The same authors also adopted Koch's name "*Actineda*" instead of Heyden's earlier *Amystis* for the genus founded upon the type of *Trombidium cornigerum* Hermann; but this they were probably justified in doing, because *Amystis* had been employed by Savigny for a genus of Vermes in 1826, I think before Heyden's date. I have thought it best to use the name "*Cilliba*" for the genus of Uropodinæ; giving *Discopoma* in brackets, and if zoologists consider that they are at liberty to adopt the latter name I shall be glad.

*Dinychus*.—It has been suggested that Canestrini's genus *Fedrizzia*, of which there is not any European representative, is closely allied to *Dinychus*; there seem to me, however, to be substantial differences.

*Uroseius*.—I have not seen the adult of the only species constituting this genus. Judging from the nymph (Haller's *Uropoda elongata*), I should say that it is properly included in the Uropodinæ;

Berlese's description of the adult makes it rather doubtful whether it should be so included; but as he is the only person who has seen the adult and he classifies it amongst the *Uropodinæ*, I treat it as being so, relying upon his opinion.

*Celæno*.—This generic name, which is adopted by Berlese and Canestrini, cannot be maintained, because before Koch used it for a genus of Acari in 1835 it had been used by Leach for a genus of Mammalia in 1822; and *Celæna* was used by Stephens for a genus of Lepidoptera in 1829. Even if the name had not been pre-occupied it could not, in my opinion, have been properly used for the present purpose, because, as already pointed out by Kramer, Koch's *Celæno* was a genus of *Oribatidæ*, and the characters of that family, which is widely separated from the *Gamasidæ*, must be included in it. Koch only put *ægrola* into the genus because he mistook it for one of the *Oribatidæ*, to which family all the other species belong. Koch himself in the 'Uebersicht' (Heft 3, p. 108), points out the absence of some of the principal characters of the *Oribatidæ*, and says that *ægrola* cannot remain in the genus *Celæno*, and is only put there because he did not know where else to put it. It is true that probably all these species are immature forms, and therefore it might be argued that the genus had failed and that a subsequent writer had a right to use the name for something else; but surely no one had a right to use it for the very creature which Koch had introduced in error, and refer the genus to Koch; so that Koch's definition of it, including all the *Oribatid* characters, would be supposed to mark out a group of creatures to all of which they were utterly inapplicable. As the generic names *Trachynotus* and *Celæno* have failed I have called the genus "Trachytes," as being, I believe, the nearest unused name to Kramer's.

*Polyaspis*.—This is a genus on the very borderland of the *Uropodinæ*. There is not any recorded species which is known to have been found in Britain. I possess a species, but it is unrecorded; there is not any room on the plates accompanying the present paper for its illustration, and therefore I do not describe it.

*Uropodella*.—There is not any known European species of this genus, nor have I ever seen a specimen. I have doubts whether it is properly included in the *Uropodinæ*; I only do so because Berlese, who has seen the only known specimens, has done so.

The following table will express my ideas. I have kept as closely to Berlese's table as I could.

#### UROPODINÆ.

*Gamasidæ* with the genital aperture of the male within the sternal plate; the camerostoma (camerostrum), or opening for the oral tube, ventral; the dorsum projecting beyond it, and the first pair of legs

inserted within it. Mandibles long and thin, with fine chelæ similar in both sexes.

With excavations of the ventral surface for the reception of the legs.	{	Body regular in form. Dorsum regularly vaulted or arched, and without sculpture except pitting or areolation ..	{	First pair of legs with ambulacra (claws and caruncles) }	<i>Uropoda</i> .		
			{	First pair of legs without ambulacra .. .. . }	<i>Cilliba</i> ( <i>Discopoma</i> ).		
		Body irregular in form; dorsum not regularly vaulted or arched, but sculptured .. .. . }			<i>Glyphopsis</i> .		
Without such excavations	{	Body of adult protected by fused dorsal and ventral plates ..			<i>Dinychus</i> .		
		Dorsal and ventral plates not fused .. .. . }	{	Adult without ventral plate except the genital operculum (epigynum) .. .. . }	<i>Uroseius</i> .		
				Dorsal and ventral plates conspicuous ..	{	Genital plate of female distinct from the sternal	{
		{	First legs without ambulacra				<i>Polyaspis</i> .
						Genital plate of female fused with the sternal ..	<i>Uropodella</i> .

DESCRIPTIONS OF NEW SPECIES.

*Uropoda hamulifera* sp. n., plate VI. figs. 5-7.

	♀	♂
Length about .. .. .	·71 mm.	·68 mm.
Greatest breadth about .. .. .	·60 "	·58 "
Length of legs, 1st pair, about .. .. .	·26 "	·25 "
"    2nd and 3rd pairs, about .. .. .	·29 "	·28 "
"    4th pair, about .. .. .	·35 "	·34 "

The striking characteristic of this species consists in the hooked hairs on the dorsal surface. There is hardly any sexual dimorphism, except that the female is a trifle the larger and of course the difference of the genital plates.

*Colour* rather pale yellow-brown.

*Texture* chitinous, dull, without any polish.

*Shape* nearly elliptical, a trifle wider posteriorly than anteriorly; very round posteriorly. The anterior portion projects a little, forming a short, broad, truncated trigon; the anterior (truncated) edge of this trigon is quite straight, and measures about 0·09 mm. There is also a very slight, wide, lateral projection of the periphery commencing at the base of the trigon. The whole margin is broken and irregular.

*Dorsal Surface*.—This may be considered as divided into two areas, a central slightly-domed space and a flatter, but not really flat, margin. The central space is strongly areolated, areolations about



60 to the millimetre and cup-like; the ridges between them very thin, not level, but undulated on the upper edge, rising into a sharp point between each two depressions. Rather more than half the width of the posterior and lateral portions of the margin, and the whole of its anterior portion until behind the first pair of legs is occupied by a smooth, non-areolated, chitinous band continuous with the central area, but composed of thinner chitin and having an undulated exterior margin. Beyond this edge a thin line of unchitinized cuticle is seen. The actual margin is formed by a series of about twenty-two small chitinized plates; the anterior of these on each side is narrow and triangular; the others more quadrate; each plate is rough on its exterior edge and slightly concave or undulated on its inner edge. Underneath the cuticle runs an undulated chitinous ring or bar; one or two undulations of this bar support each marginal plate at its inner edge; this is not seen by pure reflected light, but if there be any transmitted light each plate appears to have a chitinized crescent on its inner edge and the white line between the plates and the plain band looks moniliform. The plates are separated from each other by a very thin line of unchitinized cuticle.

The dorsal hairs, fig. 7, form the chief peculiarity of the species; each hair is like a longitudinal section of an inverted wedge curled over at its distal end so as to form a broad hook; it is nearly pointed at its proximal, broad and rounded at its distal end; it is flattened in the sense of being formed of a lamina, and not having a circular section like ordinary hairs. The distal hook is directed upward, or sideways, and the hairs themselves are somewhat radially placed. Sometimes the hook is imperfectly formed, and the hairs are more trumpet-shaped; they are dirty yellowish-white. There is a double row of these hairs round the margin, the outer set just under the margin, the inner on the margin plates. The central area has a row of similar hairs near its outer edge; two straight longitudinal rows, one on each side of the median line; and an imperfect ring and a few scattered hairs between the outer line and the median pair of rows.

*The Ventral Surface* (fig. 6).—There are three well-marked depressions on each side for the reception of the legs. The epigynium (genital plate) of the female is rounded anteriorly, straight posteriorly, and occupies almost the whole space between the coxæ of the fourth, third, and second pairs of legs, but does not reach much further than to the middle of the lastly-named pair. The genital aperture of the ♂ is between the coxæ of the fourth pair of legs.

*Legs* short, the second pair slightly the thickest in both sexes. The coxæ of the first pair without tooth-like projections or apophyses. All legs furnished with claws and caruncles.

*Habitat.*—I found two specimens only, ♂ and ♀, on the dead stump of a pine-tree which had been cut down, at 1 gls, near Innsbruck, Tyrol.

Unfortunately I have been forced to draw and describe this species from balsam preparations, and my memory of what they were when living. I prefer drawing and describing from the life, but had mounted these two specimens for preservation, expecting to get others.

*Cilliba (Discopoma) pandata\** sp. n., plate VI. figs. 8 and 9.

Length of ♀ about ..	·35 mm.
Breadth „ „ ..	·32 „

This is a very small species, chiefly distinguished by the form of the anterior edge of the dorsal shield.

*Colour* moderately dark red-brown.

*Texture* chitinous, polished, but not highly so.

*Shape* nearly round, but a trifle longer than broad. The central portion of the anterior edge instead of projecting, as is usual in the Uropodinæ, is bent downward and backward, *thus causing a slight incurving of the margin* which is characteristic of the species.

*Dorsal surface* very *convex*, quite smooth, without markings or large hairs; there is, however, a row of extremely fine short hairs near the periphery, rather far apart, and a few sparse rows of similar hairs on the notogaster. These hairs are too small to be shown in the figure.

*Palpi* rather long, projecting nearly as far as the first pair of legs do.

*Ventral surface* without true markings; deeply excavated to receive the legs; the excavations for the fourth tarsi are but little wider than the tarsi themselves, and run almost parallel to the edge of the body. All the excavations are bordered on the inner side by broad chitinous ridges or strengthening-pieces. The genital plate (epigynium) of the female and the ridge bordering the aperture which it closes occupy the whole space between the ridges bordering the depressions for the last three pairs of legs. The epigynium is lanceolate, the anterior end not quite pointed, the posterior end truncated, but not nearly so broad as the middle of the plate; the ridge bordering the epigynium is joined anteriorly to that bordering the hinder edge of the aperture for the oral tube; a narrow band of chitin joins the anterior edge of the same aperture to the deflexed edge of the dorsal shield. I have not found the male.

*Legs* short and thin; the fourth pair is situated rather far back. The tarsi of the first pair are thicker than those of the others, and of course, in this genus, terminate in long hairs only, without claws or caruncles.

*Habitat*.—I found this species at Kensworth in Hertfordshire, in moss.

\* *Pandatus*, bent downward in the middle.

*Glyphopsis Bostoeki* sp. n., plate VI. figs. 1-4.

Length about .. .. .	♂ and ♀.
Greatest breadth about .. .. .	1.5 mm.
Length of legs, 1st and 4th pairs, about ..	1.0 "
"    2nd pair, about .. .. .	0.67 "
"    3rd "    "    "    "    "    "    "	0.58 "
"    "    "    "    "    "    "    "	0.62 "

This is the largest and one of the handsomest species of Uropodinæ which I am acquainted with.

*Colour* darkish, chitinous, red-brown.

*Texture* very rough and quite dull.

*Shape* very irregularly pyriform.

*Dorsal surface* irregular and complicated in formation and markings; it is difficult to describe and will be best understood from the drawing (fig. 1); but I will attempt its description. The rostrum is really small and triangular, but is bordered laterally by very broad, chitinous lamellæ joined to the rostrum by their inner edges and sloping upward gradually to the outer edges, which are thus considerably raised. These two lamellæ meet in the median line at the point of the rostrum, and are fused at the lower, but free and rounded at the upper part. These lamellæ serve as protections for the first pair of legs, and are continuous with the first part of the edge of the dorsal surface, which is extremely rough and irregular. The edge, or lamella, bends suddenly outward, forming a great round projection above the ridge which divides the hollow for the reception of the second leg from that for the first leg. At this point the edge (or lamella) dips downward and runs along the lateral surface of the body on a lower level than the actual dorsum; it first forms an extremely large irregular projection above the ridge which separates the hollows for the second and third legs; this is much the largest projection and curls downward. The lamellar edge then becomes smoother and narrower, but expands again into a smaller and less well-marked rough projection above the ridge between the hollows for the third and fourth legs. After the fourth leg the edge loses its lamellar character and becomes a series of great, blunt, tooth-like projections or crenations, which border the whole posterior part of the body. Just at the rear of the projection between the first and second legs an inner ridge commences and runs all round the part of the body posterior to this point. This inner ridge is rough, undulated, and irregular; it bears a small, crest-like, lamellar expansion along its anterior part, which forms a conspicuous projection between and above the second and third projections of the lower lamella, and a number of somewhat similar, but smaller, projections along its course. Bordering the inner edge of this second, or inner ridge is a narrow but deepish trench, the chitin of which is smooth. On the inner border of this trench is a third ridge of rough chitin, much less irregular or undulated in form

than the other two, and bearing a regular series of short, fine, curved hairs directed outward. Thus the whole abdomen is bordered by three nearly parallel ridges or lamellæ; the extent to which one projects beyond the other varies in different specimens. From the inner of the three there are four small projecting ridges on each side of the body, the first two are annular, the outer side of the small ring being joined to the inner side of the outer ridge. In each of the two hinder projections the inner part of the ring is absent, leaving a semicircular ridge projecting inward from the principal ridge.

*Dorsal surface* divided into two unequal parts by a straight trench running from the inner of the three parallel ridges on one side to the same ridge on the other side. The anterior of these parts is slightly raised along the median line, and has a more or less defined, nearly triangular median space bordered by a rough, irregular, broken ridge; which anteriorly is little more than a series of small lumps or dots. Within this space, and much nearer the median line, are two other longitudinal ridges, still more irregular and broken, which approach each other in the middle, and then separate again in hour-glass fashion; at the rear part of their course there is a shallow concavity between these last-named ridges. There are four or more rough chitinous lumps on the dorsum between the two sets of ridges. The posterior part of the body has its median portion divided into three slightly concave spaces by ridges which are in effect continuations of those on the anterior part, but far less broken or irregular. All the ridges bordering or in the median space on either part of the dorsum are provided with hairs similar to those on the inner of the three peripheral ridges; except that along the transverse sulcation the hairs are spatulate, thick, and dirty white. The hinder portion of the dorsal surface, and part of the median space in the anterior portion, is coarsely and irregularly areolated (areolations from about  $\cdot 015$  mm. to about  $\cdot 035$  mm. in diameter), and the whole surface is rough and uneven.

*Ventral surface* (fig. 2).—The camerostoma is triangular; from its anterior point a short chitinous bar runs to the place where the two lamellæ fuse above the rostrum; from this point a pair of smaller and darker, but well-defined, lamellæ run along the sides of the camerostoma. The excavations for the reception of the legs are very deep and well-defined; those for the fourth pair have narrow prolongations for the tarsi directed inward and backward. The femora, when in the excavations, lie in what may almost be called pockets; having a chitinous expansion below them. There are two curved, rough ridges near the inner side of the depressions for the fourth pair of legs, running from near the coxæ of that pair to about the level of the anus. In my male specimen there are also one or two short irregular ridges behind the anus; and there is an indication of areolation of that part of the ventral plate. The junction between the dorsal and ventral plates is not easy to detect. The epigynium (genital plate of the



female) commences between the coxæ of the third pair of legs and nearly reaches those of the first pair; it does not fill up the whole space between the coxæ, being rather narrow; it is rounded anteriorly, truncated posteriorly, and slightly curved at the sides. It has a low and fine, longitudinal, median ridge. The genital aperture of the male (fig. 4) is rather broader than long, and is placed between the coxæ of the third legs.

*Legs* rather long and set far under the body; there is a considerable distance between the coxæ of the third and fourth pairs. The first pair (fig. 3) have one large and one smaller blunt tooth projecting from the outer side of the coxæ in both sexes. The femora of all the legs have a median crest underneath. The tibia of the first leg bears on its inner side a curved, blunt, chitinous rod; the tarsus of the same leg, two shorter blunt rods on its upper surfaces; a thick brush of fine, but not long, hairs near its distal end, and some other hairs. The femur of the same leg bears a fine spine on the inner side, and those of the other legs a similar, but stouter, spine on their posterior side, all directed backward and inward. There is also a sparse whorl of small hairs or spines on each genu and tibia, and some on the tarsi. All legs terminated by claws on longish peduncles, and rather small caruncles.

*Habitat.*—One pair, male and female, were found by Mr. E. Bostock in an ant's nest (that of *Lasius flavus*) near the Land's End, Cornwall, in 1892. I have named the species after him; I am not aware of any other capture of the species.

#### LIST OF THE BRITISH SPECIES OF UROPODINÆ.

This list includes all such species as are known to me, except that it does not, however, include a few species which are in my cabinet, but are still undescribed.

##### *Uropoda ovalis* Koch.

- Notaspis ovalis*, Koch, 'Deutschlands Crustaceen,' &c., Heft. xvii. fig. 21.  
 „ „ Julius Muller, "Insecten Epizoen der Mährischen Fauna," Jahresheft der Naturwiss. Sec. der Mähr-Schles. Ges., 1859, pp. 157-84.  
*Uropoda scutulata* Mégnin? "Mém. sur l'organisation, &c., des Acariens de la famille des Gamasides," Journ. de l'Anat. et de la Physiol. (Robin), May 1876.  
 „ „ Haller? "Acarinologisches," ii. Archiv für Naturges., 1881, p. 185.  
*Notaspis obscurus* Berlese, "Indag. sulle metam. di alcuni Acari insetticolli," Atti del R. Ist. Ven. di Sci., &c., 1877, p. 59.

*Uropoda obscura* Canestrini, 'Prospetto dell' Acarofauna Ital.,' vol. i. 1885, p. 103.

„ „ Berlese, 'Acari &c. Ital.,' fasc. xi. No. 8.

This species is not the *Uropoda ovalis* of Kramer, Canestrini, or Berlese. It is not the *Notaspis obscurus* of Koch with which Canestrini and Berlese identify it, neither is it the *Notaspis marginatus* of Koch nor the *Notaspis immarginatus* of the same author, with both of which Canestrini and Berlese identify it, nor is it the *Trachynotus elongatus* of Kramer with which Canestrini is inclined to identify it. Haller says that it is the *Uropoda vegetans* of Mégnin, but this does not appear to be so.

It will be seen above that great confusion has arisen in the synonymy of this species. Koch's *Notaspis ovalis* is a large species, pointed posteriorly similar to Berlese's excellent figure which is called *Uropoda obscura*. The *Uropoda ovalis* of Kramer, Canestrini, and Berlese is a smallish species quite rounded at the posterior end and not resembling Koch's species; it is probably the *Uropoda vegetans* of de Geer.

Mégnin's *Uropoda scutulata* is inserted here as a synonym with a ? in order to draw attention to it, and because Haller drew and described a creature as Mégnin's *U. scutulata* which Berlese and Canestrini identify with their *U. obscura* (the present species); but Kramer has already pointed out that it would be quite impossible to identify it from Mégnin's description; and that, as far as it goes, it is extremely doubtful (to say the least of it) whether it is the same creature as Haller describes. I thought at one time that Haller's *U. scutulata* was certainly identical with this species; Canestrini and Berlese treat it as being so, but I have since observed that Haller states that in his species the first leg is terminated by a tactile hair only without claw or caruncle; the present species has both on the first leg; if Haller be correct in his statement then his creature would belong not only to a different species but also, according to Canestrini and Berlese, to a different genus *Cilliba* (*Discopoma*).

*Notaspis obscura* Koch is a species with a broadly truncated posterior end very different from Berlese's drawing.

I have found this species in great abundance in newly mown grass thrown on top of a hot-bed (cucumber-bed) at Kensworth, Hertfordshire; I have also found it not uncommon in hot-beds and moss generally over England.

#### *Uropoda vegetans* de Geer.

*Acarus vegetans* De Geer, 'Mémoires pour servir à l'histoire des Insectes,' Stockholm, 1778, t. vii. p. 123, pl. vii. figs. 15-19.

„ „ Linnaeus, Syst. nat., t. i. p. v. p. 2933, No. 78.

„ „ Schrank, Ins. Aust., 1781, p. 524, No. 1084.

- Uropoda vegetans* Dugès? "Recherches sur l'ordre des Acariens," 3me Mémoire, An. Sci. Nat., 1834, t. 2, Zool. p. 29, pl. 33.
- " " Contarini, 'Cataloghi degli uccelli e degli insetti della provincia di Padova,' Bassano, 1843, p. 16.
- " " Mégnin? "Mém. sur l'organisation &c. des Acariens de la famille des Gamasidés," Journal de l'Anat. et de la Physiol. (Robin) May 1876, p. 327.
- " " Haller, "Acarinologisches" (2nd paper), Archiv für Naturges., 1881, p. 187.
- Uropoda ovalis* Kramer, "Ueber Gamasiden," Archiv für Naturges., 1882, p. 408.
- " " Berlese, Acari &c. Ital., fasc. xli. No. 9.
- Notaspis* " Kramer, "Zur Naturgeschichte einiger Gattungen aus der Familie der Gamasiden," Archiv für Naturges., 1876, p. 73.
- Uropoda vegetans* Latreille, Gen. crust. et ins., i. p. 158, 1806, No. 1.
- " " Koch? 'Deutschlands Crustaceen,' &c. Heft 38, pl. 19.
- " " Muller, J., "Ins. Epizoen der Mährischen Fauna," Jahreshefte der Naturwiss. Section der Mähr-Schles. Ges., 1859, p. 157.

The *Uropoda vegetans* of Canestrini ('Prospetto dell' Acarofauna Ital.') is *Uropoda tecta* Kramer, not the present species.

This is the original species of *Uropoda* upon which the genus was founded, but for no species is it more difficult to be certain what precise creature the original finder intended to describe, or to elucidate the synonymy. The description given by de Geer in his original notice of the species is evidently taken from an immature creature, a nymph, but in *Uropoda* the nymph so closely resembles the adult that this alone would not prevent the identification; but de Geer's description is not sufficient for that purpose; his plate, however, does give the form. Most of the early writers merely copied de Geer, Dugès however gives a figure which he himself remarks differs in form from de Geer's; it is very doubtful if it was taken from de Geer's species; the same may be said about Koch's figure, he not improbably really had *U. tecta* before him when he drew it. Probably the first really distinct figure was Mégnin's, but Mégnin's description does not assist it; the figure agrees well in shape with de Geer's, but the first leg in Mégnin's drawing terminates in a bunch of hairs without caruncle or unguis; de Geer's description and plate do not show how the first leg terminates (Dugès clearly has a caruncle and claws) Probably Mégnin's plate should be considered equivalent to the first correct description if it were not for the fact that, I believe, no subsequent acarologist has ever been able to find a creature corresponding to Mégnin's figure; inasmuch as the species which I think must be *U. vegetans*, and which agrees with Mégnin's in other respects, has a caruncle and claws on the first leg; and all other known species of anything like the shape of

de Geer's figure also have the first leg with caruncle and claws. It seems, therefore, probable either that Mégnin's must be some very rare French species, in which case it is not likely to have been de Geer's *Uropoda*; or else that Mégnin had overlooked the small caruncle and claws on the first leg, or that his specimens had lost them; in which case his specimens and de Geer's might well be one species. It is odd that in his figure of the under side of the female Mégnin actually drew a caruncle and claw to the first leg. I suppose this must be an oversight.

I have found the adults of this species tolerably common and generally distributed in England, in moss. I also once found a large number in the nest of one of the bumble-bees (*Bombus*). The nymph is found attached to the legs of beetles, such as *Geotrupes stercorarius*, &c., and to some other insects.

#### *Uropoda Kramerii* Can.

- Uropoda Kramerii* Can., 'Acari nuovi o poco noti,' p. 8 (1884).  
 " " " 'Prospetto dell' Acarofauna Ital.,' Parte 1  
 (1885) p. 105.  
 " " Berl., 'Acari, Scorp. e Miriap. Ital.,' fasc. 11,  
 No. 7.  
 " " Michael, "Obsns. on the Special Internal Anat. of  
*U. Kramerii*," this Journal, 1889, p. 1.

There has been a doubt whether this species might not also be the *Notaspis ovalis* of Kramer\* and the *Uropoda ovalis* of the same author; † but the genital plate (epigynium) of the female is broader in *Kramerii* than in Kramer's *ovalis*, and also is set further back, its hind edge being considerably behind the coxæ of the fourth legs, whereas in Kramer's *ovalis* it is on a level with them, and there are other differences. Anyhow Kramer's name cannot stand because he gives it identifying the species with Koch's *Notaspis ovalis*, which is an error; neither Kramer's nor Canestrini's are Koch's species.

I found this species in great numbers on the floors and walls of a hay-barn in Derbyshire. I have also found it in Cornwall, near the Land's End.

#### *Uropoda campomolendina* Berlese.

*Uropoda campomolendina* Berl., 'Acari &c. Ital.,' fasc. xlv. No. 2.

I found one pair of this species, male and female, at Kensworth in Hertfordshire in 1889, in moss.

\* "Zur Naturgeschichte einiger Gattungen," &c., Archiv Naturges., 1876, p. 73.

† "Ueber Gamasiden," op. cit., 1882, p. 408.



*Uropoda tecta* Kram.

- Notaspis tectus* Kramer, "Zur Naturges. einiger Gattungen aus d. Familie d. Gamasiden," Archiv für Naturges., 1876, p. 79.
- Uropoda tecta* Berlese, 'Acari &c. Ital.,' fasc. xli. No. 10.
- " " Haller, "Acarinologisches," 2nd paper, Archiv für Naturges., 1881, p. 184.
- " *vegetans* Can., 'Prospetto dell' Acarofauna Ital.,' vol. i. 1885, p. 104.

Canestrini\* states this species to be a synonym of *U. vegetans*, but this seems to be an error; *U. tecta* is a particularly well-marked species, sharply distinguished by the division of the dorsal shield into a large anterior and a small posterior plate; but Canestrini's *U. vegetans* is really *U. tecta*.

I have found this species several times in England in moss; it is not common, but does not seem to be local as far as I can judge.

*Uropoda minima* Kram.

*Uropoda minima* Kram., 'Ueber Gamasiden,' p. 416.

Not uncommon in dead leaves, moles' nests, &c.

*Uropoda elegans* Kram.

*Uropoda elegans* Kram., 'Ueber Gamasiden,' p. 406.

Two specimens in Epping Forest, in moss.

*Uropoda Ricasoliana* Berlese.

*Uropoda Ricasoliana* Berl., 'Acari &c. Ital.,' fasc. liv. No. 10.

Two specimens, male and female, probably of this species, found in an ant's nest near the Land's End, Cornwall. They are, however, more pointed anteriorly than Berlese's figure, and rather smaller than his measurements. Berlese found two specimens in ants' nests in Italy; I believe these are the only recorded specimens.

*Cilliba (Discopoma) cassidea* Herm.

- Notaspis cassideus* Hermann, 'Mémoire aptérologique,' p. 93, tab. 6, fig. 2.
- " " Koch, 'Uebersicht des Arachnidensystems,' Abth. iii. p. 94.
- " " Can. e Fan., "Intorno agli Acari Ital.," Atti del R. Ist. Veneto di Sci., &c., 1877, p. 59.
- " *ovalis* " Ibid.

\* 'Prospetto dell' Acarofauna Ital.'

<i>Cilliba cassideus</i>	Heyden, Oken's Isis, Bd. x. No. 2, 1828, gen. 58.
<i>Cillibano</i> "	Gervais, 'Walckenaer's Hist. nat. des Insectes aptères,' 1844, t. iii. p. 260.
<i>Oribata cassidea</i>	"     "     Tom. cit., p. 260.
<i>Uropoda</i> "	"     "     Tom. cit., p. 221.
" <i>moneta</i> ?	"     "     Tom. cit., p. 221, Nymph.
" <i>clavus</i>	Haller, "Acarinologisches" (2nd paper), Archiv für Naturgesch., 1881, p. 182.
"     "	Kramer, "Ueber Gamasiden," Archiv für Natur- gesch., 1882, p. 411.
<i>Discopoma cassidea</i>	Can., 'Prospetto dell' Acarofauna Ital.,' 1885, pt. i. p. 112.
"     "	Berlese, 'Acari &c. Ital.,' fasc. xxxii. No. 9.

Mégnin says that his *Uropoda truncata* is identical with this species, but his description hardly seems to agree with it, and if it were identical why did he name it (in the same paper as the statement)? Berlese in the paper first mentioned below favours the idea that *truncata* is *cassidea*, but this species is not the *Notaspis cassideus* of Berlese in his 'Indagini sulle metam. di alcuni Acari insetticoli,' nor his *Discopoma cassidea* in 'Acarofauna Sicula'; these are both *romana*.

Canestrini identifies it with Koch's *Notaspis orbicularis*,\* but I do not think that this is correct.

Common and generally distributed.

#### *Cilliba (Discopoma) romana* Canestrini.

<i>Discopoma romana</i>	Canestrini, G. and R., "Acari Ital. nuovi o poco noti," Atti del R. Ist. Veneto di Sci., &c., 1882, p. 15 (927).
"     "	Berlese, 'Acari &c. Ital.,' fasc. xi. No. 2.
<i>Notaspis cassideus</i>	"     "     "Indagini sulle metam. di alcuni Acari insetticoli," Atti del R. Ist. Veneto di Sci., &c., 1877, p. 32.
<i>Discopoma cassidea</i>	Berlese, "Acarofauna Sicula," Bull. Soc. Entom. Ital., 1882, p. 338.

Two specimens near Tamworth in Warwickshire, captured in the larval condition and reared to the adult.

#### *Cilliba (Discopoma) pandata* sp. n.

See descriptions of new species, p. 300.

\* 'Deutschlands Crustaceen,' &c., Heft 27, fig. 24.

*Glyphopsis splendida* Kramer.

- Uropoda splendida* Kramer, 'Ueber Gamasiden,' p. 414.  
*Discopoma splendida* Can., 'Prospetto della Acarofauna Ital.,' pt. i.  
 1885, p. 115.  
 " " Berlese, 'Acari &c. Ital.,' fasc. xi. No. 3.  
*Discopoma clypeata* G. and R. Can., "Acari Ital. nuovi o poco noti,"  
 Atti del R. Ist. Veneto di Sci., &c., 1882, p. 13.

It may be well to mention that when this handsome species is mounted in balsam, or prepared in any way which causes the thin chitin of the dorsal shield to become semi-transparent, the thick and elaborately formed supporting ridges situate on the inner (under) surface of the shield show through and give the creature a totally different appearance; so that it might easily be mistaken for a different species.

Found in moss, generally distributed in England and not uncommon, but solitary.

*Glyphopsis lamellosa* Canestrini and Berlese.

- Trachynotus troguloides* Can. e Fanzago, 'Intorno agli Acari Italiani,'  
 Atti R. Ist. Veneto di Sci., &c., ser. v. vol. iv.  
 1877, p. 62.  
*Uropoda lamellosa* Can. e Berl., "Sopra alcune nuove specie di  
 Acari Italiani," Atti Soc. Ven. Trent. di Sci.  
 Nat., vol. ix. (1884) fasc. i. p. 6.  
 " " Can., Prospetto dell' Acarofauna Ital., vol. i.  
 1885, p. 110.  
*Uropoda laminosa* Berl., 'Acari &c. Ital.,' fasc. xiii. No. 1.

The synonymy of this species is curious; Canestrini and Fanzago in 1877 called it *Trachynotus troguloides*, considering it to be the *Argas troguloides* of Gervais.\* Canestrini subsequently abandoned this idea and in July 1884 in the above-named joint paper by Canestrini and Berlese it is named *Uropoda lamellosa*, a name which Canestrini adheres to in 1885; but Berlese in his 'Acari &c. Ital.,' July 1884, and again in 1892, calls it *Uropoda laminosa* without saying why he alters the name.

This species was found by Canestrini under stones near Trent prior to 1877; the only existing specimens which I know of have, until lately, been his two or three type specimens. In the autumn of 1892 I found a considerable number of specimens of a *Uropoda* closely resembling Canestrini's and Berlese's figures and descriptions in the nests of *Formica fusca* near the Land's End, Cornwall. Prof. Canestrini was kind enough to compare some of these with his type specimens, and he informs me that they are identical. I had not felt quite

\* 'Aptères,' vol. iii. p. 262.

certain, because in 1891 I captured in Corsica a single specimen of a *Uropoda* also very similar to the drawings and descriptions of *lamellosa*, and which I had supposed to be that species, but which was not quite the same as the Cornish species, although very like it.

*Glyphopsis coccinea* Michael.

*Uropoda coccinea* Michael, Proc. Zool. Soc. London, Dec. 1891, p. 646.

Several specimens of this species have been found by Mr. Bostock at Buxton in Derbyshire in the nests of *Formica fusca*, and by him and myself in the nests of the same ant near the Land's End, Cornwall.

*Glyphopsis Bostocki* sp. n.

See descriptions of new species, p. 301.

*Glyphopsis formicarix* Lubbock, pl. VII.

*Uropoda formicarix* Lubbock, Journ. Linn. Soc. Zool., xv. (1881) p. 386.

This curious species, one of the most remarkable known, was found by Sir John Lubbock in the nests of an ant (*Lasius flavus*) which he was keeping for observation. When I drew up the description of the species for Sir John Lubbock's paper quoted above, I had only the two or three specimens which Sir John had been able to send me to describe from; I consequently was not aware that when really perfect this creature carries upon its dorsal surface a large number of thick, yellowish-white, spatulate hairs, which are so extremely caducous and easily detached that there was not a sign of them on the specimens described from; and, indeed, although I have lately obtained a considerable number of specimens, it is only rarely that I have found the hairs at all perfect.

In addition to the hairs mentioned in the original description a perfect specimen will bear the following, viz. the inner edge of each of the two great, elevated, chitinous blocks which stand on the outer sides of the central depression of the hinder part of the abdomen is bordered by a close row of large, curved, spatulate yellowish-white hairs pointed at the ends and directed almost horizontally across the body; two (paired) bunches of about three similar hairs pointing backward are situated not far from the hind margin and a little nearer to the median line; and two other bunches of similar hairs, pointing outward, project from the anterior parts of the lateral edges of the irregular rough elevated triangle on the anterior part of the abdomen. A little within these last-named lateral edges is a row of spatulate hairs similar in colour and texture, but much shorter and not pointed; a short double row of similar hairs is placed on the anterior part of this triangle in the median line, and a single row of similar hairs is



borne by a raised chitinous ridge parallel to, and some little way within, the lateral margin of the abdomen on each side. This ridge stops at the so-called shoulder, but the line of hairs, after a short break, continues a'l round the cephalothorax, and there are some scattered similar hairs on the flat of that part of the body.

I originally suggested that it was possible that the great chitinous blades which project over the second legs might be more or less flexible, but I find they are not so.

The first pair of legs are provided with caruncles and claws, which however are both small.

It will be seen from pl. VII. fig. 3 that the mandibles are not in the form most usual in the genus *Uropoda*.

Some information relative to the internal organs of this species will be found later in this paper (p. 314).

Sir John Lubbock sent me this species in 1881, but I never was able to find any specimens myself until the autumn of 1892, when I found a considerable number in the nests of *Lasius flavus* near the Land's End, Cornwall.

As the creature has not ever been figured I have thought it well to give a plate of it.

#### *Dinychus perforatus* Kramer.

*Dinychus perforatus* Kram., "Ueber Milben" (2nd paper of that title),  
Archiv. für Naturgesch., 1886, p. 255.

*Celæno inermis*? Can., 'Prospetto dell' Acarofauna Ital.', pt. i. 1855,  
p. 101.

There seems to me to be some confusion about this species, and it is difficult to say for certain what is the synonymy. The following are the facts. In 1881 Berlese, in a paper on the life-histories of Gamasidæ,\* treated of a species which he called *Trachynotus inermis*, identifying it with the *Sejus inermis* of Koch.† I do not see why it should have been supposed to be Koch's species, I should say that it is not so. It is frequently impossible to identify Koch's species with any certainty, and probably would be so in the present instance; but Koch described his species as highly polished, whereas Berlese's is covered with conspicuous perforations and is not polished; and Koch describes and draws his species as having two longitudinal sulcations on the dorsal surface, extending the greater part of its length, and Berlese's species does not show a trace of these; as, however, Berlese placed his creature in a different genus his specific name of "*inermis*" might stand if the creature were new, although it might not be Koch's "*Sejus inermis*." The genus *Trachynotus* cannot stand, having been used before Kramer, as explained in the classificatory part of this

\* "Il polimorfismo e la partenogenesi di alcuni Acari (Gamasidi)," Bull. Soc. Ent. Ital., 1882, fasc. 1, and Archives Ital. de Biol., t. ii. fasc. i.

† 'Deutschlands Crustaceen,' &c., fasc. 39, fig 20.

paper. Berlese's figure shows a female with a genital plate pointed anteriorly. In 1885 Canestrini (*loc. cit.*) described a creature under the name of *Celæno inermis*, which is evidently intended to be the same as Berlese's, Koch's *Sejus inermis* being again referred to; Canestrini, however, described the genital plate of the female as rounded anteriorly, and as coming rather farther forward than Berlese draws it; in other respects it seems very similar to Berlese's species; if they be not identical then the name of "*inermis*" clearly belongs to Berlese's species and not to Canestrini's. The genus *Celæno* cannot stand any more than *Trachynotus*, having also been previously used (before Koch) as above explained. In 1886 Kramer (*loc. cit.*) described a species which he considered new; he founded the genus *Dinychus* for it; his figures and description are not very perfect, and he did not find the female, so that the shape of the genital plate cannot be traced. In his later work\* Berlese adopts Kramer's genus and calls his species *Dinychus inermis*; he gives more careful figures which show the whole creature more parallel-sided and broader posteriorly than Kramer's drawing; two strong spines on the first joint of the palpus in Kramer's species are apparently absent in Berlese's. The English specimens which I have hitherto found are all of one species, which agrees in form rather with Kramer's species than Berlese's; Canestrini's description of the form also seems more like Kramer's; the English specimens have the genital plate of the female quite rounded anteriorly without any sign of a point; the plate extends far forward as Canestrini describes, and fills up almost the whole sternal space from near the front of the coxæ of the second legs to the middle of the coxæ of the fourth legs. As the shape of the genital plate of the female is an important matter in identifying Uropodinae, I think that the species of Kramer, Canestrini, and my own are probably identical, and I have therefore called it "*Dinychus perforatus* Kr.," and I imagine Berlese's to be a different species; if they should ever turn out to be the same then the name of "*inermis*" should stand.

I have found the species widely distributed, but rare, in England. I have also found it at Loch Maree in Scotland.

#### *Uroseius acuminatus* Koch.

*Uropoda acuminata* Koch, 'Kritische Revision der Insectfauna Deutschlands,' Bd. iii. 1847, p. 260, pl. 10, fig. 110.

*Uroseius* .. Berlese, 'Acari &c. ital.,' fasc. lix. Nos. 3 & 4.

*Uropoda elongata* Haller, "Acarinologisches," Archiv für Naturges., 1881, p. 186, Nymph.

Three or four specimens of this creature in the nymphal stage were found by Mr. Newstead in a wild-bees' nest at Colwyn Bay, Wales.

\* 'Acari &c. Ital.'

*Trachytes ægrota* Koch.

*Celæno ægrota* Koch, 'Deutschlands Crustaceen,' &c., fasc. 32, fig. 5.

„ „ Berlese, 'Acari &c. Ital.,' fasc. 38, No. 10.

For further remarks as to the identification and synonymy of this species see the next species—*Trachytes pyriformis*.

Kramer, Canestrini and Berlese assert that either this or the next species (they do not distinguish between the two) is the *Gamasus lagenarius* of Mégnin. I do not see the reason for this; I should say that it was not possible to identify anything from Mégnin's description, but Mégnin's species is not his own but Dugès', to whom he refers; and Dugès' description would not suit the present or the next species.

Found by Mr. E. Bostock at Colwyn Bay, Anglesea, and by myself in Cornwall; local and rather rare.

*Trachytes pyriformis* Kramer.

*Trachynotus pyriformis* Kram., "Zur Naturgeschichte einiger Gattungen aus der Familie der Gamasiden," Archiv für Naturges., 1876, p. 80.—"Ueber Gamasiden," op. cit., 1882, p. 420.

„ „ Can. e Fan., "Intorno agli Acari Italiani," Atti del R. Ist. Veneto di Sci. &c., 1877, p. 63.

*Celæno ægrota* .. Canestrini, 'Prospetto dell' Acarofauna Ital.,' vol. i. 1885, p. 101.

A good deal of confusion has arisen as to this species and the last (*ægrota*). What seems to me to have happened is this; Koch originally described what he called *Celæno ægrota* (I have already explained that his genus cannot stand); Koch's figures and descriptions were never very good. Long subsequently Kramer found a creature which he called *Trachynotus pyriformis* (his genus cannot stand any more than Koch's); he does not seem to have known of Koch's prior description, &c.; but he subsequently discovered it, and as this species is very like *ægrota*, there not being more difference than there often is between Koch's figure and description and the creatures he was actually drawing and describing, and as Kramer only knew of one species, he naturally thought it was Koch's *ægrota*, and he says it is in his "Ueber Milben"; he gives very good reasons for not adopting the genus *Celæno*, but it is not quite apparent why, thinking them identical, he did not drop his specific name of *pyriformis* and adopt *ægrota*; luckily he did not do so. Canestrini and Fanzago seem, from their figures, to have found Kramer's species; they adopted his name and his synonymy, they do not seem to have known that there was more than one species. Berlese seems to have found what really was Koch's species and not Kramer's; he did not think that there were two species, he had one, and as Kramer said his was Koch's Berlese

naturally supposed that his own and Kramer's were identical; he knew that Kramer's genus could not stand but does not seem to have known that Kceb's could not; he called his species *Celæno ægrota*, falling back on Koch's name, and he was perfectly correct in saying that his species was *ægrotæ* (judging from his figure); but he was, in my opinion, incorrect in identifying it with Kramer's species. Canestrini in his later work follows Berlese in adopting the name of *Celæno ægrota*, but as he identifies it with the former description and figure of Fanzago and himself, it must be presumed that the species he has is really *pyriformis*. The confusion arises from neither naturalist having the two species. There are, however, two species which, although closely allied, are clearly distinct; both are British, and I have several specimens of each. The best figure and description of *ægrotæ* are Berlese's; the best of *pyriformis* Kramer's. Berlese in his description of the genus *Celæno*, published long after his description of the species, gives a rough figure of Kramer's species and says it is *ægrotæ* with the nymphal skin persisting. This seems to me an error, and it would not account for the different shape of the genital plate of the female. The principal differences are as follows:—1. The rostrum of *pyriformis* is much broader and more rounded anteriorly than that of *ægrotæ*, and is bordered laterally by horizontal blades of thin chitin not found in *ægrotæ*; these blades are marked with diagonal parallel lines. 2. The median line of the abdomen in *pyriformis*, particularly the hinder part, bears a strong and conspicuous chitinous ridge not found in *ægrotæ*, and there are some minor ridges proceeding from it; on the other hand the anterior part of the body in *ægrotæ* bears a longitudinal median trench well shown in Berlese's figure, but not found in *pyriformis*. 3. The genital plate (epigynium) of the female of *pyriformis* is narrower anteriorly and broader posteriorly than that of *ægrotæ*, which is much more oblong, although not quite oblong. 4. *Pyriformis* is somewhat the larger species.

Generally distributed in England, but rather rare.

#### OBSERVATIONS ON THE ANATOMY OF *Glyphopsis formicariæ*, plate VII.

In this Journal, 1889, pp. 1–15, I have dealt with the internal anatomy of *Uropoda Kramerii*, and in 1890, pp. 142–52, with some variations of the female reproductive organs in other species. I only propose here to mention those points in which the present species differs from those before described, without repeating what has been already said where the organs are nearly similar.

#### *The Exo-skeleton and Trophi.*

The first remark here is that if the dorsal shield be dissected off and turned over so that the inner surface is exposed to view it will be seen that the large spoon-shaped depression in the hinder part of



the dorsum, which forms such a characteristic feature of the species, is formed of thinner chitin than the remainder of the notogaster; while in the elevated parts at the side the chitin is extremely thick and dense. It will also be seen that the curved transverse markings which cross the depression are not mere outer thickenings or differences of colour, but are actual foldings inwards of the dorsal shield itself, and project on the inner surface of the tergum; the two sides of the fold have coalesced so as to form one ridge; but these ridges are not all quite similar, some are deeper and larger than others; the more shallow ridges usually have quite sharply pointed ends, whereas the deeper ones, where the folding of the ends has not been effected in the same manner, mostly swell out, forming slightly bulbous terminations. It may also be roughly said that almost all the numerous irregularities and sculpturings of the dorsal surface are produced partly or entirely by out-pushings or in-pushings of the chitinous cuticle, not by mere thickenings.

The *mandibles*, fig. 3, are scarcely of the type most usual in the Uropodinæ, they are somewhat shorter and thicker, and the chelate portion is more powerful. They contain a very good example of what is not very unusual among Acarina, viz. that the tendon by which the muscle communicates with the movable chitinous part which it works is not attached directly to the movable part, but is attached to a small loose chitinous piece (*c*) from the opposite end of which another short tendon runs to the working part; this chitinous piece probably serves to some extent as a fulcrum, and enables a slight change in the direction of the line of force to be obtained.

The *hypostome* (maxillary lip), fig. 4, is characterized by the extreme fringing with long hairs of the paired lateral parts (*gal*) which Mégnin calls the "galeæ"; they stand out like great brushes of hair in a very unusual manner. The long rod or spine, which Berlese calls the "style" (*st*) is also much developed for one of the Uropodinæ.

The *palpi* (fig. 5) are very short, thick, and conical; the basal joints being much larger than is usual in the sub-family.

*Oral tube.* There is a rather remarkable median pair of serrated spines articulated to the under-side of this organ; one of them is drawn (fig. 6).

#### *The Alimentary Canal.*

It will be seen on comparing fig. 7 with the drawing of the alimentary canal of *Uropoda Kramerii* (fig. 8 of the plate illustrating my paper published in this Journal in 1889) that there are considerable differences between them, although of course the general principle is the same. The present species much more resembles the short description given (without a special figure) by Winkler of what he calls *Uropoda obscura* (Koch).\*

\* Winkler does not figure or describe his species; there is a little uncertainty as to what it was, as he possibly followed Canestrini and Berlese in their nomenclature, which, in this case, I do not think correct. See the synonymy of *Uropoda ovalis* Koch, at p. 303 of this paper.

Instead of the large square ventriculus, the cæca of which are mere shallow projecting corners, which we find in *U. Krameri*, the present species has the ventriculus considerably smaller and longer in shape, and the cæca (cæ) which arise from the corners are very long and important; probably no two specimens exactly agree, but all are sufficiently similar to be immediately identified by any one knowing the organs, even if he were not told the species. The hind pair of cæca are the wider, and are of nearly equal width throughout; where they arise from the posterior corners of the ventriculus they run outward and backward until they are opposite the middle of the colon, they then turn sharply inward and backward and terminate about opposite the posterior end of the colon, which organ they thus almost surround. The two cæca at the anterior corners bifurcate as in Winkler's species, but in *G. formicariæ* the two branches are very unequal; the posterior branch is directed transversely across the body, and is practically a continuation of the proximal portion of the cæcum before the branching. At its distal end this cæcum is suddenly enlarged so as to form a great irregular lobe which has somewhat the shape of a human foot turned backwards; this lobe not only widens greatly superficially, but also becomes suddenly thicker dorso-ventrally than the remainder of the cæcum. The anterior branch is the thinner, and does not enlarge at its distal end; it is directed at first forward, then curves slightly outward, and lastly more strongly inward; it and its fellow on the opposite side of the body practically nearly surround the brain. Instead of the five small anterior cæca found in *U. Krameri* two only are present in *G. formicariæ*. Winkler does not mention any in his species. Almost the whole of the ventriculus and its cæca is decidedly, but irregularly, scalloped, i. e. divided up into minute shallow lobes or corrugations.

#### *The Reproductive Organs.*

The female genital organs differ so little from the usual type in *Uropoda*, e. g. *Uropoda Krameri*, that it is not, I think, worth saying anything about them here, except as regards the perigynium, or inner, membranous, genital plate. This organ seems to vary in form and construction in every species; that of *G. formicariæ* is shown at pl. VII. fig. 10, as seen from below; viewed from that direction, the oval space at the anterior end is concave, and the keyhole-shaped portion in the centre is elevated; the row of spines directed inward from the edge of this portion is on the surface of the organ furthest from the eye (the true upper surface) and is only seen in consequence of the transparency of the parts.

The male reproductive organs show considerably more difference from the type of *U. Krameri* than the female do. Five sacs or organs exist in addition to the central chamber, but as the fifth shows signs of being formed from two paired organs the number fairly agrees

with the six of *U. Krameri*; but it is very difficult to homologize them with the parts in that species, or with the five organs without central chamber shown by Winkler in his short description and diagram. In the present species the central chamber (pl. VII. fig. 8, *vs*) is very much smaller than in *U. Krameri*, and the testes, &c., seem to communicate with it directly, not by means of a small antechamber, as in that species. The five sack-like organs which communicate with it consist, *firstly*, of a very large accessory gland (*ag*), far larger than any of the other organs of the system; this at its hind-margin, &c., shows plain signs of having arisen from the coalescence of two paired glands; it is clearly the homologue of Winkler's unpaired gland; but it is not at all apparent that there is any homologue to it in *U. Krameri*; for the two posterior sacks in that species are evidently the homologues of what Winkler, I believe correctly, considers as the testes.

The paired organs (*tt*) are evidently the testes in this species; and they contained filiform spermatozoa as well as spermatogenous cells in the specimens which I dissected; it is rather difficult to say whether this single pair of testes is the homologue of the anterior pair or the posterior pair in *U. Krameri*; it is probably the latter, although the appearance is rather of being the former; if they represent the posterior pair, which is most probable, then they may also be considered to represent the single pair of testes in Winkler's species; which is what would be anticipated. The form of each testis in *G. formicariæ* is much more that of a nearly globular gland with a longish duct than of the gradually diminishing flask-shaped organ found in the other species; in fact, it is much more plainly differentiated into testis and vas deferens. About half-way between the anterior and posterior ends of the great accessory gland, and half covered by that organ, lie a pair of almost globular glands (*gl*) not as large as the testes, but still of substantial size; they are formed of moderately large columnar cells with thin walls, and appear to function much like the "oil-glands" of *U. Krameri*; they are, however, much further back than those organs; still it is not improbable that they are really the homologues both of the oil-glands and of Winkler's secondary accessory glands (*Nebenanhangsdrüsen*), but undoubtedly the position is not exactly what might be expected if they be.

The ductus ejaculatorius in this species is short and wide; its opening to the exterior is a simple round hole (*ga*) surrounded by a thick chitinous ring (*cr*) projecting exteriorly; from this a supporting lamina of thin chitin runs along each side and part of the ventral surface of the ductus ejaculatorius, but it does not extend to the upper surface. I have not found this support in the other species of Uropodinæ which I have dissected.



*Coxal and Racemose Glands, and Expulsory Vesicles.*

It is in these glands that the most marked departure from anything yet described in the Uropodinæ occurs.

*Coxal Glands.*—These are not unknown among the Gamasidæ. Winkler figures one as attached to the third leg of *Gamasus fucorum*; it appears small, and is furnished with a duct which is very small in diameter, but rather long; he says very little about it in his letter-press, but there he puts a query to the expression "coxal gland." As far as I understand the intention of his few words, he implies that he found these glands connected with all the legs.

*G. formicariæ* possesses a well-marked and rather large coxal or super-coxal gland on each side of the body, but it is attached to the second leg only; I was not able to find any similar organ attached to either of the other legs. The gland is rather flattened, somewhat irregular in shape, but more or less oval, and is composed of medium-sized secreting-cells; it communicates with the coxa by a largish, irregularly undulated duct. The form of the parts and the size and position relatively to the coxa may be judged of from fig. 11, which is drawn to scale; and the appearance of the gland and duct seen on edge is shown by fig. 12 more highly magnified.

The remarkable feature of the organ is the extremely large size and fleshy nature of the duct, which almost appears like a prolongation of the gland and as if it had some glandular function itself. The duct is very large and thick, and varies much in width in different parts, but in a wholly irregular manner; its lumen, however, is small.

*The racemose glands*, or perhaps I should rather say the organs to which I propose giving that name, are new to me; I cannot recollect any really similar organs in the Gamasidæ, or indeed in any other Acarina; they lie immediately under the cuticle of the dorsal surface, and are composed of smallish rounded cells which stain deeply with carmine, &c.; they are paired organs, those on the opposite sides of the body corresponding, although each may vary somewhat in detail from its fellow. These glands are numerous, and exhibit considerable differences in form and size; but they are all organs of the same character; composed of similar cells, branching in a tolerably similar manner, all the branches of one gland being in one plane, so that the organ may be said to be flat; the whole plane may be somewhat curved, but the individual branches do not spread over or under those adjoining them. Far the largest of these organs is placed near the lateral edge of the dorsal surface immediately beneath the cuticle, on each side of the body, near the third leg. One of these is drawn (fig. 13), and the drawing will probably convey a better idea of it than any description. It will be seen that it is a richly-branched organ, the branches all of more or less equal width, and each branch maintaining a tolerably even width throughout, except for a tendency to become slightly enlarged at its distal end. It will also be seen that all



branches communicate directly, or indirectly, with a nearly central point; which probably is the point of discharge. A smaller similar organ is found further back, behind the insertion of the fourth leg; also near the lateral edge of the dorsum, on each side, immediately under the cuticle; and a whole row of pairs underlie the two nearly median, rough, elevated ridges on the anterior part of the dorsum; these, however, are much smaller than either of the two pairs before mentioned.

I cannot say with any certainty what is the function of these organs, but I suppose them to be dermal glands. Dermal glands are common in many of the Acarina; the Hydrachnidæ, as a rule, are particularly richly provided with them, and they are well known in other families; it is true that they are usually globular or discoidal glands, and that I cannot point to any other known instance in the Acarina of the richly branched condition of the dermal glands which we find in the present species; but then, as before stated, I cannot point to any similar organs at all in the order; yet here they are present, and they appear to be glandular. Their position and distribution seem to favour the idea that they are dermal glands.

*Expulsory vesicles*, the organs to which I gave this name in the Oribatidæ, had long been well known in the Tyroglyphidæ, having been described by Claparède and others; I myself have lately recorded their existence in some Gamasidæ,\* and they exist in other families; but I am not aware that their presence in any of the Uropodinæ has been hitherto ascertained.

They are more or less flattened sacs lying near the surface in the lateral part of the posterior half of the abdomen; they contain an oily fluid, most often yellow, and discharge to the exterior by a fine pore; they are usually looked on as excretory. *G. formicariæ* is provided with one of these organs on each side of the body; it is a slightly flattened sac (fig. 14), and lies between the second and third legs just below the great raised block of dark chitin which is placed at the side of the median spoon-shaped depression.

\* "On the Variations in the Internal Anatomy of the Gamasinæ, &c.," Trans. Linn. Soc., 2nd ser., Zool., vol. v. pt. 9 (1892) p. 311.

---

SUMMARY OF CURRENT RESEARCHES  
RELATING TO  
ZOOLOGY AND BOTANY  
(PRINCIPALLY INVERTEBRATA AND CRYPTOGAMIA),  
MICROSCOPY, ETC.

*Including Original Communications from Fellows and Others.\**

ZOOLOGY.

A. VERTEBRATA:—Embryology, Histology, and General.

a. Embryology.†

Experimental Embryology.‡—Dr. W. Roux defends his position against the criticisms of Driesch and Hertwig. It will be remembered that according to Roux's results, each of the first four blastomeres of the frog ovum forms, with a measure of independence, a quarter of the embryo, and that if one of the first blastomeres be punctured, the remaining half forms a half-embryo (right or left, anterior or posterior), and that the development generally proceeds like mosaic work. Each of the early blastomeres is specialised according to Roux, whereas according to Driesch and Hertwig they are all equivalent.

The first part of his paper contains a detailed answer to some of Driesch's criticisms, a counter-criticism, and an explanation of what is meant by self-differentiation as contrasted with dependent differentiation. Driesch shows that when pressure on the segmenting Echinoid ovum produces great disarrangement of cells, or that when some are entirely removed, a normal *Pluteus* larva is still formed, therefore, Driesch concludes, the blastomeres are for some time mutually equivalent. But he does not show that the normal result is attained in anything like the normal way. Roux would explain the normal result as due to the residual powers of regeneration and post-generation.

The processes of regeneration and post-generation are then discussed.

\* The Society are not intended to be denoted by the editorial "we," and they do not hold themselves responsible for the views of the authors of the papers noted, nor for any claim to novelty or otherwise made by them. The object of this part of the Journal is to present a summary of the papers *as actually published*, and to describe and illustrate Instruments, Apparatus, &c., which are either new or have not been previously described in this country.

† This section includes not only papers relating to Embryology properly so called, but also those dealing with Evolution, Development and Reproduction, and allied subjects.

‡ Biol. Centralbl., xiii. (1893) pp. 612-25, 656-72.

According to Roux, the regenerative mechanism is set at work mainly by the absence of the normal neighbour-influences, and the process spreads from the area of defect to the other cells. He recognizes two modes of development: the normal or direct, in which there is a typical system of definitely determined processes; and the indirect or atypical, in which the post-generative processes are at work—when, for instance, the half-embryo of a frog forms a whole embryo. He goes the length of speaking of the idioplasm of direct development, and the idioplasm of indirect development, the latter being awakened by the now well-known methods of artificial embryology.

The main antithesis is obvious. Roux and Weismann believe in the specific character of the early blastomeres; Driesch and Hertwig believe in their mutual equivalence. When a part of a segmented ovum gives rise to a normal whole, the latter say the fact proves the mutual equivalence of the early blastomeres; the former say that it illustrates regenerative and post-generative processes.

**Placentation of the Shrew.\***—Prof. A. A. W. Hubrecht devotes the third of his ‘Studies in Mammalian Embryology’ to this Insectivore. He finds that the placentation of the shrew is brought about by sets of processes in the maternal tissue and the blastocyst that are at first independent of one another; later on, when the blastocyst has come to adhere against the maternal tissue, they are closely related; still later the mother contributes nothing but blood.

The maternal processes are unexpected and somewhat peculiarly shaped local distensions of the wall of the uterus, with changes in the distribution of glandular tissue, &c., in this wall; there are, also, considerable local proliferations of maternal uterine epithelium.

The embryonic processes are local changes in the outer wall of the blastocyst, with special development of certain portions of the trophoblast which finally constitute a syncytium, in which the allantois-villi and the embryonic blood are in the closest contact with maternal blood; the latter circulates in spaces of embryonic tissue without any endothelial lining.

The result of the changes in the tissue of the uterine wall is the formation of a concave bell-shaped surface, opposite the mesometrium, on which there open a number of newly formed epithelial crypts, between which there are some glandular openings. Lateral cushion-shaped surfaces are also formed, against which the blastocyst first adheres by means of a zonary strip. Against this strip the blood-vessels of the area vasculosa on the yolk-sac spread out. In the embryonic syncytium already mentioned there may be distinguished a zonary syncytium in the region of the area vasculosa; this owes its origin to that portion of the surface of the blastocyst that the author calls the “omphaloidean trophoblast.” Opposite the mesometrium there is a bell-shaped syncytium, which owes its origin to that part of the outer wall of the blastocyst which expands simultaneously with the formation of the amnion, and which the author calls the “allantoidean trophoblast.”

In the course of further changes this trophoblast is applied against the concave maternal surface, and sends knob-like projections into the

\* Quart. Journ. Micr. Sci., xxxv. (1894) pp. 481-537 (9 pls.).

mouths of the maternal crypts, with the result that the maternal epithelium is destroyed wherever the trophoblast adheres; it then undergoes a differentiation into an outer layer which assumes the syncytial character more fully and contains paler nuclei, and an inner layer, the nuclei of which stain more strongly. Internuclear spaces are developed in the plasmodioblast, and enter into communication with the maternal spaces that have been laid bare after the disappearance of the maternal epithelium. The trophoblastic protuberances that have penetrated into the crypts are hollowed out, and allantoidean villi enter into these cavities. Later on, newly formed villi are enclosed by a trophoblastic matrix identical with that around their earliest predecessors. As the placental region increases in breadth, space is gained for the free development of these secondary villi; at the same time the maternal proliferation flattens out and becomes a covering for the growing placenta, and is finally reduced to isolated nuclear remnants. In the final stage of the placenta the allantoidean villi are no longer recognizable as such, and the intervening trophoblast is stretched to the utmost; the thinnest layer of plasmodioblast tissue is then the only separation between the maternal and the embryonic blood-fluids.

Prof. Hubrecht thinks it is clear that the placenta is essentially an embryonic neo-formation which is permeated by maternal blood that circulates in spaces devoid of endothelium. This embryonic neomorph is preceded by a considerable proliferation of maternal epithelium, which does not enter into the constitution of the ripe placenta, but affords facilities of fixation and nutrition for the new formation in its earliest stages.

**Development of Müllerian Duct in Mammals.\***—Dr. M. J. van Erp Taalman Kip first examined the development of this duct in various Insectivora, *Tupaia*, *Talpa*, *Erinaceus*, and *Sorex*. Of these the first is the easiest to understand; in it the Müllerian duct consists of two parts which are genetically quite distinct; the ostium and the part of the duct nearest it arise from the peritoneal epithelium, while the remainder of the duct is largely derived from the Wolffian duct. The number of infundibular orifices laid down to form the permanent ostium varies somewhat; generally three are laid down, of which two are further developed. Much the same conditions obtain in *Talpa*. In *Erinaceus* the part derived from the peritoneal epithelium is shorter than its homologue in the two preceding genera.

These observations appear to the author to afford a simple explanation of the difference between Selachians and Urodeles, where the Müllerian duct arises from the archinephric duct, and Reptiles, where it is independent of it. The difference between the upper and lower parts of the duct is widely diffused among Vertebrates; in Selachians it becomes independent from behind forwards, while the complete independence seen in Reptiles, many Birds, and perhaps, also, many Mammals, is cenogenetic. Animals closely related to one another may show great differences, and as the same is true of varieties of one and the same species, we can understand why observers have obtained contradictory results.

\* Tijdschr. Nederl. Dierk. Vereen., iv. (1894) pp. 71-174 (Dutch), pp. 175-84 (German *resumé*), 3 pls.



The author is, further, of opinion that different mammals may have ostia tubæ which are not homologous; in the Mouse and the Rabbit the ostium is found in a different part of the Wolffian body from that of Insectivora. In the Mouse the vertical piece of the Müllerian duct is laid down at the same time as the ostium of Insectivora, while the definite ostium of the mouse is formed much later, and only acquires a secondary connection with the vertical piece of the duct. The Müllerian duct of the Mouse arises from a rudimentary ostium, which must be homologized with the ostium of the Insectivora. In the Rabbit there is a rudimentary ostium which is doubtless homologous with that of Insectivora, while the definite ostium does not appear till later, and then at quite a different place.

**Development of Thymus, Thyroid, and Carotid Glands.\*** — M. A. Prenant finds that the carotid is a blood-vascular gland, that is to say, it is an epithelial organ penetrated by vessels, which, like the head of the thymus, arise at the expense of the third endodermic branchial pouch. The author's observations on the thymus confirm essentially the facts stated by Kölliker, de Tourneux, and Herfmann for the histogenesis of this gland, those of Flemming for the histological arrangement of the parenchyma, and those of Hansemann for the cytogenesis of the elements of the thymus. In sheep-embryos of 85 mm. or more, the thymus becomes differentiated into a cortical mass and a medullary substance, the latter being clearer, of looser texture, and much poorer in lymphatic elements. In the cortical substance a peripheral zone becomes differentiated, and is, without doubt, a proliferating zone, for there are to be seen in it mitotic figures which are wanting in the rest of the cortical substance. It is probable that the epithelial cells, after having multiplied actively by kinesis, give rise to lymphoblasts, either by kinesis or by nuclear stenosis. In the latter case small nuclear buds may be observed to be produced, and small nuclei may be seen near larger nuclei, or even in the same cell. It is probable that a certain number of epithelial cells persist in the completely developed organ under the form of supporting cells; these may be compared, both in destiny and form, as well as by the constitution of their nucleus, to the supporting cells of the testicle, while the masses of lymphocytes would be comparable to the seminal elements.

Summing up his results as to the thyroid gland, the author remarks that the fourth endodermic branchial pouch is formed of two branches, the inner of which is prolonged and dilated into a pyriform vesicle. In the angle of the two branches there is formed, by the thickening of the epithelial wall of the pouch, a body which may be called the thyroid gland. By its trabeculated and reticulated structure, by the histological character of its epithelial elements, and because of its great and precocious vascularity, and above all by its mode of formation, this body is comparable to the carotid gland. It has nothing in common with the thymus. In the course of development a cavity appears, the wall of which is formed by an epithelium that is at first stratified, and afterwards simple; around it is produced a dense tissue of cellular and reticulated appearance, which disappears later on.

\* La Cellule, x. (1894) pp. 87-184 (4 pls.).

**Median Groove of Triton.\***—Prof. C. Van Bambeke finds that in Urodeles, and especially in *Triton alpestris*, the median, or dorsal, groove is a vestige of the primitive groove. It may be admitted, with Hertwig, that this median groove represents the line of suture along which the lips of the blastopore became fused; and it is, therefore, comparable to what Hatschek called the gastrular raphe in Ascidians, *Amphioxus*, and Annelids. If this be correct, we may say that the mesoblast on either side of the groove is a peristomial mesoblast, in the sense of Rabl; and this is the view almost simultaneously taken by F. Keibel, who has been investigating the development of the domestic pig.† No less than the evidence brought forward by O. Hertwig and Davidoff, that afforded by the history of *T. alpestris* favours the theory of concrecence.

**Fecundation of Egg of Trout.‡**—Prof. H. Blanc has had the opportunity of making some experiments on the artificial breeding of *Trutta lacustris*. He finds that the germinal vesicle does not disappear towards the end of the maturation of the egg, but is transformed into a polar spindle even while the egg is contained in the abdominal cavity. The first polar globule is expelled as soon as the egg leaves the body. On contact with water the germ and yolk execute movements which, though slight, and short in duration, suffice to vary the position of the nucleus of the egg in relation to the micropyle. Fertilization takes place half a minute after the commingling of the sexual products; it is rare for more than one spermatozoon to enter. At this time the second spindle prepares for the expulsion of the second polar globule and the elaboration of the attractive sphere of the female pronucleus. The maturation of the egg is not complete till the two attractive spheres have been elaborated by the two sexual nuclei.

The fact that the two polar globules are expelled from non-fecundated eggs, shows that fertilization has nothing to do with the phenomenon. Although the protoplasm of the germ of the egg may play the part of a nutritive structure to the pronuclei, it does not remain indifferent to the centres of the future attractive sphere, which rapidly find in it the contractile elements which allow of their playing their “dynamic rôle.”

The male and female pronuclei are attracted towards one another with equal intensity by the attractive spheres, but it may happen that one of them acts for a moment with the greater intensity. When the attractive spheres have fused, and although the nuclear membranes have disappeared, the identical contents of the two pronuclei do not at once mix. This, however, is effected, and there results a nucleus with a single reticulum enclosed in a distinct membrane.

In cases of polyspermy it is the first spermatozoon which succeeds in penetrating into the micropylar canal that alone is transformed into the male pronucleus.

**Vertebral Column of Ganoids.§**—Herr C. Hasse, in his fifth communication on the development of the vertebral column, discusses the

\* Arch. de Biol., xiii. (1893 [published 1894]) pp. 147-62 (1 pl.).

† Cf. p. 123 of Morphol. Arbeiten, iii. (1893).

‡ Ber. Naturf. Gesell. Freiburg i/B, viii. (1894) pp. 163-91 (1 pl.).

§ Zeitschr. f. wiss. Zool., lvii. (1893) pp. 76-96 (2 pls.).

state of affairs in Ganoids. His chief result is that the cartilaginous and bony Ganoids are, like the Anura, without an intercuticular sheath. Thus they differ essentially from Elasmobranchs, Dipnoi, and Urodela, in which the intercuticular sheath is present.

**Development of Kidneys in Sturgeon.\***—Dr. H. F. E. Jungersen communicates some observations on the development of the kidneys in *Acipenser sturio*, in regard to which there is a lack of definite information. His most important result appears to be that the pronephros, which extends over five to six segments, has numerous funnels, but only one capsule and one glomerulus. It is thus more primitive than that of *Lepidosteus*, and shows a considerable resemblance to that of Amphibian larvæ.

**Bibliography of Vertebrate Embryology.†**—Mr. C. S. Minot has prepared a list of 3555 papers dealing with this subject, and he has, he says, brought together about seven times the number of titles found in any previous bibliography of the subject, known to him. "Nevertheless it is far from complete." It will, however, be of great service, and may well be the foundation for a more perfect bibliography. The titles are grouped under subjects, which are arranged alphabetically, and there is an index of authors.

### β. Histology.

**Minute Structure of Nerve-centres.‡**—Prof. Ramon y Cajal, in his Croonian lecture, reminded his hearers that Golgi, who was the first to use the silver impregnation method, showed that the protoplasmic expansions of nerve-cells terminate by free extremities in the grey matter, and that the prolongations of the nerve-cells give off in their course through the grey matter very fine ramifying collateral branches; Cajal has shown that axis-cylinders, in addition to their protoplasmic prolongations, end freely in the grey substance. His investigations do not admit of his allowing the sharp difference noted by Golgi between sensory and motor cells; for example, in the olfactory bulb and retina there are cells which are morphologically motor, and others which are sensory; it is clear, therefore, that the function of a cell cannot be deduced from its shape and mode of branching.

The grey matter of the spinal cord, in addition to commissural, connecting and motor cells, has others which are called "pluricordonal," as in them a complex axis-cylinder furnishes two, three or more medullated fibres in connection with the columns of one side or of both.

After entering into numerous details the lecturer expressed his belief that mental activity is not able to improve the cerebral apparatus by augmenting the number of cells, for the nervous elements lose their power of dividing during embryonic life; it is, however, probable that intellectual exercise may produce in certain regions of the brain a large development of the protoplasmic apparatus, and of the system of nervous collaterals, so that associations already existing between certain groups of nerve-cells would be perfected by a further development of terminal twigs, of protoplasmic endings, and of nervous collateral branches, while

\* Zool. Anzeig., xvi. (1893) pp. 464-7, 469-72 (1 fig.).

† Mem. Boston Soc. Nat. Hist., iv. (1893) pp. 487-614.

‡ Nature, xlix. (1894) pp. 464-6.



quite new intercellular connections might be established by a new formation of collaterals and of protoplasmic expansions.

As compared with the theory of networks, that of the free branching of cellular expansions capable of growth appears not only more probable but also more encouraging.

**Nerve-cord of Rays.\***—M. v. Lenhossék finds that the nerve-cells of the spinal cord of Rays are much more similar to those of Amphibia than to those of Teleostei, while there are points of resemblance to the Reptilian cord. The most striking peculiarity is the fine protoplasmic marginal plexus, the morphology and physiology of which require further examination.

**Altmann's Bioplasts.†**—Drs. L. and R. Zoja support a modification of Altmann's theory, according to which protoplasm is a colony of elementary organisms or bioplasts united by an indifferent matrix. They find peculiar little fuchsinophilous plastidules in all sorts of animal cells, characteristically disposed in the various types, and believe that the particles have a nutritive function in the cell.

**Degeneration of Cells and Nuclei.‡**—Herr L. Drüner has studied the cause of certain forms of cellular degeneration. He begins with that observed in the testes of *Salamandra maculosa* during the summer months. As to the actual facts of the degeneration, he has little to add to what has been observed by Flemming and Hermann, but his interpretation is different, for he finds that the degeneration is due to a parasite. The same is true of the epithelial cells of the gut. More than one cell-parasite seems to occur; for the one which is responsible for the "karyolysis" described, the author proposes the name *Micrococidium caryolyticum*.

**Specific Character of Cell-divisions.§**—Dr. D. Hansemann recently published a paper entitled "Studien über die Specificität, den Altruismus und die Anaplasie der Zellen," in which he sought to show that the cells of various tissues show quite characteristic differences in their mitoses. In that paper all his observations related to the tissues of Man. Now, however, he has extended his observations to other organisms with similar result. Thus he has studied, in the larva of *Salamandra maculosa*, the epithelium of the mylohyoid plate, the connective-tissue cells of the branchial lamellæ, and the red blood-corpuscles, and finds that the mitosis of each kind of cell is specifically characteristic, as regards form and arrangement of the chromosomes, the position of the spindle, and the size of the centrosomes.

**Physiology of the Cell.||**—Dr. J. Demoor claims to have demonstrated for two well-marked and essentially different cases that there is a marked independence between the life of the protoplasm and that of the nucleus. The former is only manifested in the presence of oxygen, the latter goes on regularly in a medium which is insufficient to maintain the active life of the protoplasm. Chemical reagents produce very

\* SB. Phys.-Med. Ges. Würzburg, 1893, pp. 156-7.

† Rend. R. Ist. Lombardo, xxiv. (1891) pp. 981-8.

‡ Jenaische Zeitschr. f. Naturwiss., xxviii. (1894) pp. 294-327 (2 pls.).

§ Arch. f. Mikr. Anat., xliii. (1894) pp. 244-51 (1 pl.).

|| Arch. de Biol., xiii. (1893 [published 1894]) pp. 163-244 (2 pls.).



different effects on the two parts of the cell. Reacting on one another, owing to their very distinct functional attractiveness for one another, the two parts have different duties in the individual life of the cell. A close "mutualism" is established between the different regions of the cell, each of which is the seat of numerous diverse activities.

The life of the physiological unit—call it energid, tentorium, or cell—is not the result of a function which owes its origin to the combined work of its different parts; it is the consequence of the regular combination of a large number of very dissimilar activities which arise in various organs, and which converge towards one resultant, while preserving their own existence and value.

Just as the physiology of the higher animals has succeeded in breaking up the life of an organism into a series of more or less special functions, some of which may cease for the moment without bringing about the definite ruin of the whole, so cellular physiology has succeeded in showing that the same is true of the primordial organism. The final conclusion of the author's work is that the life of the nucleus is essentially different from that of the protoplasm.

The cell is exceedingly complex; we must not forget that we know only some lines of its history; the new conception of its physiology is unknown to all but students of cytology; it would be well for physiology and general pathology if it were more widely known.

#### γ. General.

**Genetic Relations of Metazoa.\***—Mr. W. Schimkéwitsch is of opinion that the Metazoa derived from the hypothetical Trochozoon passed through a stage which may be called that of the Enterocœlula, in which there was a pair of cœlomic sacs. In the next stage this cœlom divided into two parts, the cœlom of the cephalic trunk and tentacles and the cœlom of the trunk; this may be called the Tentaculiger-stage. The Bryozoa, the Phoronidæ, the Sipunculidæ (?) and the Echinozoa are arrested at this stage; in the first three the metanephridial system is developed in the hinder part, and in the last in the anterior part of the body-cavity. In the Chætognatha and Brachiopoda (?) the hinder part of the body-cavity is divided into two, and, in consequence, the number of metanephridial tubes is increased to two pairs; the Chætognatha have lost the tentacles.

In the Enteropneusta the anterior part of the cœlom is divided into two portions, the anterior of which corresponds to the cephalic lobe, while the posterior is prolonged into the tentacles. These last are retained by *Cephalodiscus*, but lost in the polybranchiate Enteropneusta (*Balanoglossus* and *Saccoglossus*). In the Acrania we may see the part homologous with the anterior section of the body-cavity of the Tentaculiger-stage; the hinder part is divided into a series of segments, and the metanephridial system is developed in the hinder part. The relationships of the groups are indicated by a table, in which the Tentaculiger-stage is above the Enterocœlula; to the right branches off the Notoneura Chordata, and to the left the Triarticulata (Brachiopoda and Chætognatha) and the Tentaculata (Rhabdopleuridæ, Bryozoa, Phoronida, Sipunculida, and Echinozoa).

\* Congr. Intern. Zoologie, ii. 2 (1893) pp. 215-40.

**Organisms in the Chicago Water Supply.\***—As there may still be some microscopists who regret that they did not visit the World's Fair at Chicago, they may like to know what was to be found in the water supplied in the grounds. Dr. S. E. Jelliffe found one Crustacean, two Rotifers, six Infusoria, seventeen Diatoms, and nine other Plants. This was indeed a place for collecting material.

## B. INVERTEBRATA.

**Natural History of British Columbia.**—A beginning has been made with the preparation of lists of the Invertebrata of British Columbia. Messrs. W. H. Danby and C. de B. Green report on the Entomology,† and Dr. C. F. Newcomb on the Crustacea‡ and Marine Shells.§

### Mollusca.

#### a. Cephalopoda.

**Brooding Habits of Octopus Digueti.**||—Prof. E. Perrier and M. A. T. de Rochebrune describe the habits of this new Californian *Octopus*; it lays its eggs in the empty valves of Lamellibranchs and broods over them. Each egg, of which there may be sixty in one bivalve, is contained in a thick ootheca, attached to a valve by a filament 4 mm. long. The young Octopod is, at birth, 5.5 mm. long and 3 mm. wide, while the yolk-sac is of considerable size.

#### γ. Gastropoda.

**Proboscis of Prosobranchs.**¶—Herr A. Oswald has particularly studied the proboscis of *Buccinum undatum* and *Nassa reticulata*, which belong to what Ray Lankester calls the pleurembolic type. Oswald proposes to call the space between the introvert or proboscis and its sheath the *rhynchodæum*, its anterior opening the *rhynchostome*, the opening at the apex of the proboscis the *pharyngostome*, and the oral aperture proper, where ectoderm joins endoderm, the *gastrostome*. After describing the complex musculature, he notes that the salivary glands open (ventrally) some distance in front of the boundary between the cuticularized (ectodermic) epithelium and the ciliated (endodermic) epithelium, and are therefore to be regarded as originally ectodermic glands. The musculature of proboscis, foot, pharynx, &c., is peculiar since its fibres do not consist of homogeneous contractile substance, but have the fibrils limited to the periphery around an axis of granular sarcoplasm. The author also discusses the mechanism of evagination and invagination.

**Nervous System of Dreissensia polymorpha.\*\***—M. Toureng points out the existence of a supplementary, reniform ganglion between the cerebro-visceral connection and the branchial nerve. From this ganglion

\* Amer. Mon. Micr. Journ., xiv. (1893) pp. 310 and 11.

† Bull. Nat. Hist. Soc. Brit. Columbia, 1893, pp. 11-18 (1 pl.).

‡ Tom. cit., pp. 19-30 (4 pls.).

§ Tom. cit., pp. 31-72.

|| Comptes Rendus, cxviii. (1894) pp. 770-3.

¶ Vierteljahrsschrift Naturf. Gesell. Zürich, xxxviii. (1893) pp. 346-53.

\*\* Comptes Rendus, cxviii. (1894) p. 544.

there arise (1) a fine connective which, after a more or less long course, fuses with the cerebro-visceral connective; (2) a series of fine nerves which pass to the gill of their own side; (3) a nerve-trunk which fuses with the branchial nerve, and gives off fine branches to the median part of the gill, and (4) a prolongation which, by union with other nerves, forms a large-meshed network.

*Gadinia peruviana*.\*—Dr. L. Plate has had the opportunity of finding a number of this Gastropod on the coast of Chile. The mantle forms a circular fold around the whole body, as in *Patella*, and is divisible into a central smooth zone, and a peripheral zone which is rich in glands. The opening of the air-space can be closed by a sphincter, when the animal goes under water. From before backwards there follow one another the mantle-cavity, the kidney, part of the gonads, and the liver with a few intestinal coils. The first of these is asymmetrical in form, and has the kidney in its roof; anteriorly this roof widens out as a delicate membrane, but has no aggregation of blood-vessels. The kidney has a large cavity in its interior, and on its walls there are a number of villi and folds, which produce a spongy appearance. There is no special ureter, the urine being emptied into the commencement of the respiratory duct by a small papilla.

The pharynx, which is elongated, has no jaw; the teeth of the radula are extraordinarily delicate and small. The cesophagus is remarkable for having opening into either side of it, posteriorly, a sac 2 mm. long; these would appear to be salivary glands. There is no sharply defined stomach. The animal is a vegetable-feeder.

The seven centres of the nervous system are easy to demonstrate, as all the commissures are distinctly developed. The central ganglia are connected by a long commissure. The two small buccal ganglia are easily overlooked, as they lie deep in the wall of the pharynx. The hermaphrodite gland, which is large, is composed of a number of vesicles loosely connected with one another; the copulatory organ is a simple muscular tube without glands or stimulating apparatus.

The author thinks that *Gadinia* is not a Pulmonate Gastropod, but an aberrant Opisthobranch which has lost its gills, and breathes by its integument.

**Anatomy and Physiology of *Ancylus lacustris* and *A. fluviatilis*.**†—M. E. André finds that the muscular system of these Molluscs is only slightly differentiated; there are two columellar muscles. The renal organ is said to be quasi-embryonic in character. There is no pulmonary cavity, nor any organ specially adapted for respiration; this process is largely effected by the pallial pad, and slightly by the auriform lobe. This last is not a gill, but the homologue of the appendix of the pneumostome of *Physa* and *Planorbis*; the animal respire air dissolved in water, but respiration is not active, and the creature can without harm remain for a pretty long time in a medium deprived of oxygen. Circulation is almost entirely lacunar, as there is a total absence of veins. The central nervous system is composed of eight ganglia in *A. fluviatilis*, and of seven in *A. lacustris*.

\* SB. Ak. Berlin, 1893, pp. 959-62.

† Rev. Suisse. Zool., i. (1893) pp. 427-61 (1 pl.).

## 5. Lamellibranchiata.

**Oogenesis and Segmentation in *Cyclas*.**\*—Herr H. Stauffacher gives an account of the first stages in the segmentation of *Cyclas cornea*, which have not been previously described. The ovum divides into a macromere and a micromere, then the micromere divides equally, and its daughter-cells likewise, so that the five-cell stage consists of a macromere and five micromeres. The mesoderm arises directly from the division of the macromere into two equal parts, and is paired from the outset. Ziegler's supposition that the invaginating cylindrical cells of the endoderm might arise from one large cell, conspicuous during segmentation, is correct.

## Molluscoïda.

## a. Tunicata.

**Evolution of Præoral Lobe.**†—Mr. A. Willey, who has lately tried to show that the fixing organ of the Ascidian larva is both morphologically and actually a præoral lobe, suggests that the relations it holds in Protochordates and Vertebrates, as compared with those that obtain in Invertebrates, is due to its complete emancipation from the central nervous system; simultaneously with this emancipation there has been a change in the formation of the lobe, so that the nervous elements of the Invertebrate præoral lobe are entirely lacking in Vertebrates, while the mesodermal element is represented by the præmandibular head-cavities which give rise to most of the eye-muscles.

**Genital Products in Polyclinidæ.**‡—M. Caullery gives a brief account of his observations on the degeneration of the genital products in the Compound Ascidians *Circinalium concrescens* and *Polyclinum luteum*. He is led to adopt the view of Kowalewsky, that, in the germination of the Polyclinidæ, the genital organs of the bud arise directly from those of the parent. He has, in fact, observed in them, at all stages, a continuous genital tube which appeared to him to arise directly from the indifferent epithelial portions of the genital apparatus of the parent. As, on the other hand, he has observed a very distinct rudiment of a genital cord in the oozoid there would seem to be a continuity between the genital products of all the individuals derived from one egg.

**Metamorphosis of *Distaplia magnilarva*.**§—Prof. W. Salensky has studied this form in order to test his theory as to the origin of metagenesis in Tunicates. He describes the structure of the larva, the origin of the primordial bud, and the degenerative metamorphosis. Comparing the degeneration of *Distaplia* with that of *Botryllus*, the author notes that in both cases the phenomena consist in the disassociation and liberation of cells; that some of the freed cells, most in fact, pass into the cavity of the bud or nutritive stolon to become mesenchyme elements; that others (the muscular cells of the body-wall in *Distaplia* and of the tail also in *Botryllus*) serve as nourishment for phagocytic wandering cells; that a third set—a small remainder—form a mass of débris which is probably

\* Vierteljahrsschrift Naturf. Gesell. Zürich, xxxviii. (1893) pp. 361-70 (4 figs.).

† Anat. Anzeig., ix. (1894) pp. 329-32.

‡ Comptes Rendus, cxviii. (1894) pp. 666-8.

§ Morphol. Jahrb., xx. (1893) pp. 449-542 (5 pls., 1 fig.).



also absorbed; that the muscle-cells undergo partial degeneration—especially nuclear—before they fall victims to the phagocytes; that the free phagocytic cells behave in two ways; some devour the dead muscle-cells (and probably also the notochord-cells), while others serve for absorption of yolk and form packets along with the endoderm-cells. Salensky calls these “necrophagocytes” and “synphagocytes” respectively.

The author’s general conclusion is that the buds of *Distaplia* are homologous with the buds of other Ascidians and with the stolo prolifer of the metagenetic Tunicates, representing a transition between these two forms of asexual reproduction. He believes that the nurse-generation of metagenetic Tunicates has arisen from the larval stage of ascidian-like forms, which had the power of multiplying by buds, and attained sexual maturity, and that the stolo prolifer of metagenetic Tunicates has arisen from a bud in which budding has been replaced by fission.

**Visual Organ of *Salpa*.**\*—Sig. F. Todaro is convinced as to the structural correspondence between the visual organ of *Salpa* and the Vertebrate eye. The organ in question consists of a pigmented layer and a retina, derived from a common rudiment which arises by delamination from the upper part of the cerebral vesicle. In the aggregate forms it is transformed into a variable number of secondary eyes, some of which are rudimentary. These also vary from species to species. The primitive eyes or the well-developed secondary eyes show the following layers: (1) a layer of nerve-fibres (the cerebral part); (2) a nuclear layer of visual elements; (3) a layer of supporting rods, cuticular modifications of the epithelial cells and (4) a pigmented layer. The supporting rods are comparable to those in the Vertebrate eye. An answer to the recent observations of Göppert and Metcalf, who deny any homology between the visual organ of *Salpa* and the Vertebrate eye, is promised in a forthcoming memoir.

#### Arthropoda.

**Classification of Arthropoda.**†—Mr. J. S. Kingsley proposes a scheme of classification which he thinks adequate to the present state of our knowledge of this group. The first sub-phylum of Branchiata contains the two classes Crustacea and Acerata; the former are divided into two sub-classes, the Trilobitæ or Palæocarida, and the Eucrustacea—a term for which we cannot say *sit venia verbo*. For the latter, Grobben’s classification is adopted as follows:—

- Super-order I. Phyllopoda.
  - Order 1. Euphyllopoda.
  - „ 2. Cladocera.
- Super-order II. Estheriæformes.
  - Order 1. Ostracoda.
- Super-order III. Apodiformes.
  - Order 1. Copepoda.
  - „ 2. Cirripedia.
- Super-order IV. Malacostraca or Branchipodiformes.

\* Atti R. Accad. Lincei (Rend.), 1893, pp. 374–81 (1 fig.).

† Amer. Natural., xxviii. (1894) pp. 118–35, 220–35.

## I. Leptostraca.

Order 1. Nebaliidæ.

## II. Eumalacostraca.

Order 1. Stomatopoda.  
,, 2. Thoracostraca.  
,, 3. Arthrostraca.

The Acerata are divided into two sub-classes; the first, Gigantosthraca or Merostomata, contains as order i. the Xiphosura with the Limulidæ, and Hemiaspida for sub-orders, and the Eurypterida; the second subclass is that of the Arachnida, in which eight orders are recognized, Scorpionida, Thelyphronida, Araneidæ, Solpugida, Pseudoscorpia, Phalangida, and Acarina.

The second sub-phylum is that of the Insecta or Antennata, and contains two classes, the Chilopoda and the Hexapoda, while the third sub-phylum is that of the Diplopoda or Chilognatha. The author is uncertain as to the position of the Pycnogonida, Linguatulina, Pauropoda, Tardigrada, and Malacopoda; in using this last name he reverts to Blanchard's name given in 1847 for the group now generally known by Moseley's name of Protracheata.

## a. Insecta.

**Anatomy and Development of Male Genital Armature of Lepidoptera.\***—M. A. Peytoureau, who has had an opportunity of examining the development of the armature in *Bombyx mori*, considers that the abdomen of male Lepidoptera is formed of ten urites, for the uncus is to be regarded as the tenth urotergite and the scaphium as a tenth urosternite. The penis is placed between the ninth and tenth urosternites.

**Female Genital Armature of Lepidoptera.†**—M. A. Peytoureau thinks that the more or less complete monographs which have, in recent years, dealt with the genital armature of female Insects have not looked at the subject from the morphological point of view; it is necessary to study the changes which go on during development. When that is done it is found that the abdomen of female Lepidoptera is really composed of ten urites; of these the eighth is generally modified, but is always recognizable in the adult; the ninth is atrophied and united to the tenth, and this last is formed by a tergite only. The canal of the copulatory pouch, which is chitinized in several species (e. g. *Acherontia atropos*) opens between the seventh and eighth sternite. The anus and the copulatory orifice occupy the same position as in Orthoptera cursoria, while the orifice of the oviduct is distinctly modified.

**Evolution of the Worker-Caste among Ants.‡**—Prof. C. Emery arranges ants in the following series, according to the relations of the worker-caste to the rest of the colony.

I. Ants with only large workers. This is the primitive state, illus-

\* Comptes Rendus, cxviii. (1894) pp. 542 and 3. † Tom. cit., pp. 358-60.

‡ Biol. Centralbl., xiv. (1894) pp. 53-9.

trated by almost all Poneridæ, many Myrmicidæ, several Dolichoderidæ and Camponotidæ. In most Poneridæ, the workers differ but slightly from the queens, and in some species (*Odontomachus hæmatodes* and *chelifer*, *Pachycondyla villosa*) there are transitional forms between workers and queens.

II. Ants with large and small workers (Di- and Polymorphism of workers). Here (*a*) the extreme forms may be connected by intermediate grades, as in many Myrmicidæ, most Camponotidæ, *Azteca* among the Dolichoderidæ; or (*b*) the large and the small forms are distinct castes without intermediate forms:—the soldiers and workers of *Pheidole*, *Acanthomyrmex*, some species of *Camponotus*, and among these most species of the sub-genus *Colobopsis*. Here it may be noted that it seems a general fact true of both ants and termites that the reduction of the reproductive organs is associated with a stronger development of the head.

III. Ants with only small workers, which are very different from the females. This state is supposed to have arisen from the dimorphic condition, through the disappearance of the large workers. To this grade belong only a few genera, such as *Solenopsis*, *Carebara*, and perhaps *Monomorium*. In some there are hints of dimorphism.

IV. Ants with only one kind of worker, much smaller than the females, but differing from III. inasmuch as they seem not to have sprung from dimorphic forms, but to owe their relative inferiority in size to an increase in the size of the females. There are often slight differences in the size of the workers. This condition seems to have arisen "polyphyletically," and occurs in species of *Iridomyrmex*, *Dorymyrmex*, in many species of *Lasius*, and in most species of *Crematogaster*. The small males give some hint of the original size of the females, which is retained in some species.

V. Lastly, there is a disappearance of the worker-caste, in consequence of parasitism. This is completely illustrated by *Anergates* and probably by *Epoecus*, and is hinted at in *Strongylognathus*. In *Tomognathus* there seem to be no normal queens, but only parthogenetic workers.

The phylogeny of ants is unfortunately unknown; Emery presupposes merely a primitive society such as is found in many Poneridæ and Myrmicidæ. He supposes that in such a society the art of rearing sterile workers had been discovered, and that the origin of workers depends on a special capacity of the germ-plasm to react to a certain nutrition which hastens the development of some parts and retards others, of jaws and brain, as against wings and gonads. Besides qualitative differences in nutrition there are also quantitative differences, probably older, in consequence of which the workers remain smaller than the queens. Presupposing an instinct for rearing workers, Emery believes that their origin depends mainly on the quality of the food, their differentiation more on the quantity. His general idea is that the qualities which distinguish the workers from the sexual animals are not innate or blastogenic, but acquired or somatogenic. They are not transmitted as such, but in the form of a capacity which the germ-plasm has to react to given conditions. Similarly, myopia is somatogenetic, but has a blastogenic foundation.

**Production of Sound by Ants.\***—M. C. Janet has made some experiments with ants which lead him to think that the numerous rugose surfaces on the bodies of ants are so placed that two of them can be rubbed together on the organs which produce the stridulating sounds of the Formicidæ; it is allowed, however, that these rugosities have other uses, as those about the articulations seem to hold the body stiff at those points.

**Antennary Nerves and Chordotonal Organs in Ants.†**—M. C. Janet has found chordotonal organs in various regions of the body of Ants other than the tibiæ. One of the most remarkable accompanies the nerves of the antenna, and may be called the pre-antennary organ. Another is placed on the prothoracic ganglion. The latter has been found in the wasp and bee, but the former appears to be peculiar to ants.

**Hypermetamorphosis of Cantharidinæ.‡**—M. J. Künckel d'Herculais finds that it is under the form of a "pseudo-chrysalis" that vesicating Insects with retarded development pass, in a lethargic sleep, several summers and several winters. In fact they are encysted like Gregarines, many Infusoria and Nematodes; in this encysted state development is arrested, and life remains latent until the external media become favourable. This so-called hypermetamorphosis is, therefore, comparable to encystation.

The author objects to the term pseudo-chrysalis, and proposes to replace it by that of *hypnotheca*, while for the similarly objectionable term hypermetamorphosis that of *hypnodia* may be substituted. The latter new term may be applied to analogous phenomena of arrest of development with encystation, in which there is no histolysis or histogenesis.

**Salivary Glands of Crabronidæ.§**—M. Bordas finds that these organs, which have never been investigated, consist of five pairs—thoracic, supracerebral, mandibular, sublingual, and lingual. He gives some details as to the form and structure of each, but offers no generalizations.

**Tracheal System of Larval Hymenoptera.||**—M. Bordas appears to be the first who has investigated the anatomy of the tracheal system of the larvæ of Vespidæ. He finds that it consists of two long lateral and parallel cylinders, which give off transversely numerous ramifications; these are united anteriorly by a large trunk, and posteriorly by two branches of unequal size, which form a circumrectal ring.

**Formation of Silk.¶**—Prof. G. Gilson finds that the silk-producing apparatus of the larvæ of Phryganidæ is very similar to that of the larvæ of Lepidoptera, and that the silk is formed in the same way. The chitinous tube of the anterior portion of the glandular tube forms an interesting object for the study of the genesis and signification of the cellular membrane. As the origin and cytoplasmic nature of this part of the cell are evident, it is impossible to consider the cellular membrane

\* Rev. Scient., 1894. See Amer. Natural., xxviii. (1894) pp. 270 and 1.

† Comptes Rendus, cxviii. (1894) pp. 814-7 (2 figs.).

‡ Op. cit., cxviii. (1893) pp. 360-3.

§ Tom. cit., pp. 363-5.

|| Op. cit., cxviii. (1894) pp. 664-6.

¶ La Cellule, x. (1894) pp. 39-61 (1 pl.).



as a product excreted by protoplasm and solidified; it is really a peripheral differentiation of this last in which certain parts of the general reticulated system are enclosed.

### β. Myriopoda.

**Developmental Stages of Julidæ.\***—Dr. C. Verhoeff finds what he has called a *Schaltstadium* in the life-history of *Julus italicus* Latzel. This species has a flagellum which is absent in those other Julidæ in which the author has observed a *Schaltstadium*, with a many-jointed first pair of legs. The possession of a well-developed flagellum is regarded as characteristic of the genus *Julus*, which the author separates from five genera previously included within it, and divides into nine subgenera.

**Eyes of Scutigera coleoptrata.†**—Dr. Th. Adensamer describes the minute structure of the eyes of this Myriopod, corroborating in great part the results previously reached by Grenacher. In external appearance and in pigmentation the eye resembles that of Insects and Crustaceans. But while the crystalline cone in the latter is usually formed by the one-sided secretory modification of four cells whose nuclei persist, that of *Scutigera* is formed from five to seven cells whose cell-substance and nuclei are transformed into the crystalline body, which is surrounded by a persisting membrane. The crystalline cone of Insects and Crustaceans lies in front of the retinula; that of *Scutigera* is enveloped by the retinula. In the sensitive part of the ordinary faceted eye there are usually seven cells; the retinula of *Scutigera* consists of two rows, the upper of nine to twelve cells, the lower of four or three. On account of these and other peculiarities, the author proposes to call this type of eye a "pseudo-faceted eye."

### δ. Arachnida.

**Eyes of Harvestmen.‡**—Dr. F. Purcell homologizes the two eyes or Phalangids with the median eyes of Scorpions; but the former have no central cell and no inter-retinular pigment-cells. The work is without any illustrations.

**Revival of Tardigrades.§**—The note by M. D. Lance on this subject does not state exactly to what extent "dessication" was carried; only those Tardigrades revived after it which live in media that are alternately wet and dry. The drying must be slow, and when it is it is not followed by death but by slowing down of all the vital functions. The power of revival is due to adaptation to the conditions of the medium.

**Appendages of Pygidium of Triarthrus.||**—Mr. C. E. Becher, continuing his observations, states that the material lately worked out in the Yale Museum leaves little to be desired in the way of perfect preservation.

\* Zool. Anzeig., xvi. (1893) pp. 479-82.

† Verh. Zool. Bot. Gesell. Wien, xliii. (1893) pp. 573-8 (1 pl.).

‡ 'Ueber den Bau der Phalangiden-Augen,' Berlin, 1894. See Amer. Natur., xxviii. (1894) pp. 345 and 6.

§ Comptes Rendus, cxviii. (1894) pp. 817 and 8.

|| Amer. Journ. Sci., xlvi. (1894) pp. 298-300 (1 pl.).

In *Triarthrus* the thoracic legs near the head are composed of comparatively long joints, and the endopodite is seen to be adapted for crawling, and the exopodite for swimming. In the pygidial region the proximal part of the endopodite forms a paddle-like organ. In a young form a striking resemblance may be seen to the endopodites of *Apus* or to a typical phyllopod limb.

**Artificial Segmentation of *Limulus*.**\*—Mr. W. Patten finds that gravity seems to determine the position of the blastopore, but has no influence on the position of the embryo, or on its planes of symmetry in reference to the blastopore. He notes that apparently insignificant changes in external conditions are capable of producing profound modifications of the normal mode of growth. One result of his observations is to confirm him in his belief in the relationship of *Limulus* to Vertebrates. If, that is, the eggs of *Limulus* under abnormal conditions segment mesoblastically and develop "yolk blastopores" like those of Ganoids and Amphibia, it is regarded as almost certain that if these conditions became constant their result would become constant too.

#### e. Crustacea.

**Luminous Organs and Compound Eyes.**†—Prof. C. Chun makes an interesting contribution towards an understanding of the conditions of vision at great oceanic depths. His investigations relate to the Euphausiæ, which are of especial interest, since they occur both at the surface, and in abyssal darkness. It is therefore possible to study their adaptations comparatively.

*The luminous organs.*—Besides the stalked eyes, there are similar organs on the sides of the thorax, and between the four anterior abdominal legs. Claus called them (1863) "accessory eyes," Murray and Sars proved their intense "phosphorescence." Sars also isolated the striated body in the centre of the organs, and showed that it was the seat of the luminosity.

In young forms there is, as Sars showed, a small luminous organ beneath the eye, except in the blind *Bentheuphausia*.

It lies on the posterior external surface of the faceted eye, and is simpler than those on thorax and abdomen. It consists (1) of a parabolic reflector or tapetum, perforated by the nerve and covered by transient cinnabar-red pigment; (2) of concentrically disposed lateral lamellæ; (3) of the central "fibrous fascicle," or "striated body," or "luminous body,"; and (4) of a layer of cells between the luminous body and the reflector. The essential luminous body is formed of a radially arranged series of lamellæ enclosing a central space with elongated cylindrical cells. Sars spoke of this organ as fixed, but, in *Euphausia gracilis*, Chun has seen it move, and has demonstrated the associated striped muscle fibres.

The thoracic and abdominal organs are usually smaller, but they are more complicated. Thus they have a dioptric lens arrangement. They are moved by muscles, and throw their light in various directions. If compared with an eye, the lens would represent a crystalline cone, the

\* Zool. Anzeig., xvii. (1894) pp. 72-8.

† Biol. Centralbl., xiii. (1893) pp. 544-71 (8 figs.).

reflector a tapetum, the striated body a rhabdom, the surrounding cells a retinula; but Chun and Sars agree in regarding the organs in question as *sui generis*. Some of the results of R. Vallentin and J. T. Cunningham (1888) are confirmed, but Chun's analysis is more complete.

*The faceted eyes.*—The structure of the stalked eye of *Euphausia* corresponds closely with that described in *Mysis* by Grenacher. In some abyssal forms, the eye is very distinctly divided into a front and a lateral region, the former with enlarged facets. This is very well seen in *Nematoscelis mantis*, and in extreme differentiation in *Stylocheiron*. The most important deviation from the *Mysis*-type is in the absence of pigment-cells between the rhabdoms, these being replaced by pigmentation of the retinal cells themselves.

The cornea in *Euphausia* is flat, while in all other genera it has a convex curvature unusual in aquatic animals. It consists of at least two shell-like lamellæ; its formative cells lie in pairs above the crystalline cells, and are remarkable for their vesicular sickle-shaped nuclei. As in Decapods, there are four crystalline cells, but on two planes, not on one. Seven visual cells are grouped around each rhabdom. But it may be enough to state that in his description and interpretation Chun agrees with Grenacher and Exner, and disagrees as emphatically with Patten.

*Vision in the Deep-sea Schizopods.*—The "front eyes" of *Nematoscelis mantis* and *Stylocheiron* are the most perfect "darkness-eyes" that we know. They see objects which are not illumined by light from the luminous organs of the animal itself, while the lateral part of the eye perceives what the luminous organ shines upon. The "front eye" will perceive shadowy outlines, the "side eye" is adapted to receive more detailed pictures. In connection with what is known as to the movement of the pigment in illumination and in darkness, it is interesting to find that in the abyssal forms above-mentioned, the retinal pigment has disappeared, and the iris pigment is constantly in the position proper to darkness. Even in *Stylocheiron mastigophorum*, which comes to the surface occasionally, no displacement of the iris-pigment could be detected. The absence of retinal pigment is a sure sign of abyssal life, and forms with "front eyes" are almost certainly "day-blind." The peculiar convexity of the cornea may act as a compensation for the lack of pigment.

Prof. Chun's communication is one of great interest, deserving an even longer summary, but in conclusion we shall only add that he applies his results to corroborate the otherwise probable conclusion that *Euphausia* is the more primitive type, whence have been derived in ascending order, *Thysanoëssa*, *Nematoscelis*, and *Stylocheiron*.

**Early Development of Cirripedia.\***—Mr. T. T. Groom, after an introductory statement as to methods, times of oviposition, and the size and shape of the ova, &c., gives an account of the embryonic development of Cirripedes, chiefly illustrated by *Lepas anatifera*. He next discusses the free nauplius, and the first two larval stages, and afterwards proceeds to an account of their physiology. The fifth part of the memoir is devoted to general considerations, and the sixth to a bibliography.

\* Phil. Trans., 185 (1894) B, pp. 119–232 (15 pls.).

The details of the division of the cells of the blastoderm and yolk-endoderm show so much variation that the process may be termed irregular. These differences show well the morphological insignificance of the details of cell-division in the present case, for the Nauplii vary proportionately much less; every one of the numerous bristles or spines of the Nauplius has its definite character and position, which are maintained with surprising constancy throughout, and this though they must have been produced by epiblast cells of very different modes of origin and arrangement.

Early observations (1869) of Van Beneden have been neglected, and the law which he deduced from them overlooked, yet it seems certain that in Cirripedes and Copepods the surface of the embryos on which the median longitudinal and transverse furrows appear, and which has been described as ventral, is really dorsal. The mesoderm of the Nauplius shows no trace of an arrangement into somites, and the body cavity is continuous from one end of the body to the other. The author believes that the appendages of the Nauplius are all of the same kind, and may represent, as Prof. Lankester contends, for Crustacea generally, primitively post-oral appendages. At the same time it must be noted that the first two pairs of appendages are never ontogenetically post-oral.

Of the peculiar features of the Cirripede Nauplius, the most important are the shape of the carapace, with its fronto-lateral horns and caudal spine; the presence and structure of the fronto-lateral glands; the size, shape, and structure of the labrum, and the structure of its axial gland; the character of the setose region; the structure of the appendages; and the size and form of the tail. The perfect similarity which obtains in all the species examined by the author in the number, disposition and minute character of the very numerous bristles and other processes on the appendages of Nauplii of the second stage, demonstrates that the character of the appendages is a primitive one, actually possessed by the common ancestor of the Thoracica at some stage in its life-history.

The permanence of such minute characters as the arrangement of the bristles on the appendages for the vast time represented by the Tertiary, Cretaceous, and probably, at least, part of the Jurassic periods, is highly remarkable, and well shows the slow rate of evolution which may take place in so highly specialized a group.

The differences between the various larvæ are next pointed out, and it is shown that most of them affect structures peculiar to the Nauplius, and lost by the adult. The author remarks that it is evident that the variation in the Nauplii (and the same may be said of the ova and embryos), though always accompanying adult variation, has taken place in a perfectly distinct direction. Few, probably, of the other characters can be referred to larval precocity.

Mr. Groom refrains from entering on a discussion as to the origin and meaning of the Nauplius-stage, since, as the late Prof. Milnes Marshall pointed out, the origin of this larval form is outside the group.

**Post-embryonic Development of Lepadidæ.\***—Herr C. W. S. Auri-villius describes the divergences in the development of certain deep-sea

\* Öfversigt K. Vetensk-Akad. Förhand., 1. (1893) pp. 657-76.



species of *Scalpellum*. In most Lepadidæ, such as *Lepas*, *Conchoderma virgatum*, or *Scalpellum vulgare*, six stages are recognized, a nauplius, a modified nauplius (with slight modifications in shield and appendages), a metanauplius (with a fourth pair of limbs, rudiments of cirri and attaching disc, &c.), a *Cypris* stage (with a bivalve shell), a *Cypris*-pupa (after attachment), and finally a Cirriped. In certain deep-sea species of *Scalpellum* the developmental stages found within the capitulum are divergent. In *Sc. septentrionale* and *Sc. erosum* the first stage is distinctly a metanauplius, which is, however, unable to swim; in *Sc. obesum*, *Sc. cornutum*, and *Sc. prunulum* the stage observed within the capitulum was a *Cypris*, also with limited powers of locomotion. Thus there is (1) an abbreviation of the normal post-embryonic development, for the nauplius stage is passed before hatching; (2) a peculiar metanauplius and *Cypris* stage, modified apparently in relation to prolonged retention within the maternal capitulum. As the author points out, we have here a good illustration of the manner in which nearly related forms may show divergent developmental adaptations to different conditions of life.

**Parthenogenesis of *Artemia*.**\*—Dr. A. Brauer describes the process of maturation in the parthenogenetic ova of *Artemia salina*. It takes place in two ways; in the one case the segmentation spindle contains 84 chromosomes, in the other 168; the half of the first directive spindle may directly become the segmentation-nucleus, or a second division may occur without extrusion, and the two halves may form the segmentation spindle. The first process is by far the more frequent. The remarkable difference in the number of chromosomes may be seen in later cleavage stages; it persists; but the author believes only some of the ova with 168 chromosomes are capable of development. There is a single centrosome, which is very distinct in association with the segmentation nucleus, but very indistinct in association with the directive spindles, and Brauer is not inclined to credit it with any import except in connection with division. He calls it a *Theilungsorgan*.

A study of abnormal segmentation, which is very common, leads Brauer to the conclusion that the abnormality is not due to environmental conditions, but is directly associated with the parthenogenetic development, that it is due to deficiency of chromatin caused by the extrusion of a second polar body. This extrusion has been observed, and Brauer points out that in the cases of *Liparis* where two polar bodies have been observed to be extruded from parthenogenetic ova, it has not been sufficiently proved that the ova are in such cases capable of development. In the case of the bee, Blochmann's proof of the extrusion of a second polar body is not very satisfactory.

**Harpacticidæ.**†—Dr. O. Schmeil continues his description of the freshwater Copepods of Germany, dealing now with the Harpacticidæ. Hitherto the subfamily of Canthocamptinæ has included all the German forms, but the author has discovered *Ectinosoma Edwardsi* which represents the subfamily Longipedinæ. The absence of a prehensile hook on the second maxillipedes is distinctive of this subfamily. Schmeil

\* Arch. f. Mikr. Anat., xliii. (1894) pp. 162-222 (4 pls.).

† Bibliotheca Zoologica (Leuckart and Chun), Heft 15 (1893) pp. 1-101 (8 pls., 2 figs.).

describes nine species of *Canthocamptus*, of which one (*C. bidens*) is new, and his list also includes *Nitocera hibernica* Brady, *Ophiocamptus Sarsii* Mrázek, and *Ectinosoma Edwardsi* Richard.

### Vermes.

#### a. Annelida.

**Development of Ophryotrocha.\***—Dr. F. Braem gives an account of the development of *Ophryotrocha puerilis*, a small Polychæte, "like a many-jointed Trochophore, with a ring of cilia round the middle of each segment." His specimens were larger than those described by Claparède, Metschnikoff, and Viguiet; they had 30–35 segments with parapodia and a length of 10–12 mm. The frontal segment bears two pairs of antennæ with tactile hairs; the head also shows two pairs of ciliated grooves; the eyes resemble those of a *Polygordius* larva. Septa begin between the third and fourth segment, and occur regularly thereafter; each of the posterior segments bears dorsally a pair of knob-like glandular swellings projecting externally; there is a short proctodæum. The sexes are separate, the males smaller and thinner than the females. A case of hermaphroditism was also observed.

The ovaries lie on the posterior wall of the septa, underneath the gut, on each side of the ventral vessel. Among the ovarian cells there is an interesting division of labour, for some become large, nutritive cells, dark when preserved, and very rich in chromatin, while the others form the smaller ova. There appears to be a sort of competition among the ova for association with the nutritive cells, which are in the minority. Each successful ovum liberated into the body-cavity is associated with a nutritive cell much larger than itself, but gradually the proportions are reversed. Dr. Braem has an interesting comparative discussion of the relations between ova and nutritive cells. The state of affairs in *Piscicola* closely resembles that in *Ophryotrocha*.

The testes lie like the ovaries, and arise from a double longitudinal row of primitive mesoderm cells above the nerve-cord. These rows have their origin in the vegetative zone of the last segments, and the most mature testes are thus the most anterior. Spermatogenesis appears to be effected by direct division, and no polyplast stage was to be seen.

Dr. Braem has also made some observations on regenerative processes. The vegetative zone of the anal segment is the seat of the formation of new segments. After injury, regeneration begins at that spot of the wounded surface which is nearest the tail end, and progresses centripetally. The further forward the cells are the less is their regenerative power. If the hind end be cut off, the first product of regeneration is a new anal segment with a new vegetative zone. Further defects are then made good centrifugally; first the anterior and then the posterior segment are repaired. No copulation nor process of fertilization was observed. The ova issue by simple clefts of the body-wall between the parapodia, and were laid, surrounded by mucus from the ectoderm cells, on the glass sides of the aquarium. Two polar bodies are given off immediately after laying. The first cleavage is meridional

\* Zeitschr. f. wiss. Zool., lvii. (1893) pp. 187–223 (2 pls.).

and divides the ovum into two very unequal cells; the second is also meridional; the third equatorial.

The youngest larva described had a head and trunk segment; the anterior end bore a ciliated cap; below the mouth lay the first ring of cilia, the second was in the middle of the trunk segment. On each side of the anus, where paired cirri afterwards develop, there was a tuft of stiff tactile hairs, and there were similar hairs here and there on the body. The head segment becomes secondarily divided into two, and further multiplication of segments proceeds by strobilation from the anal segment.

Prof. E. Korschelt\* has studied the same animal, and the two papers are found side by side. In many respects there is of course complete agreement, but Korschelt's account is more detailed.

On the head only two ciliated grooves were seen; the first two segments of the trunk have no parapodia; the parapodia become smaller and have fewer setæ towards the hind end; the terminal segment bears two paired cirri and a more ventral, somewhat smaller, unpaired cirrus, but numerous variations occur; the abundant secretion which exudes from the very numerous epidermic glands helps the worm to attach itself.

A number of larval stages are described, but an interruption prevented the investigator from following the development completely. The structure and development of the jaw apparatus are described in detail, the point of general interest being that the successive stages resemble the conditions to be found in various subdivisions of the Eunicidæ. Like Braem, Korschelt found no nephridia, nor is there a circulatory system.

The association of each ovum with a nutritive cell is corroborated. The equatorial plate of the first polar spindle is represented by a single tetrapartite chromosome, a condition only known elsewhere in *Ascaris megalcephala* var. *univalens*. No genital pores were satisfactorily observed, though the intactness of the females after laying proves their presence.

Besides males and females, Korschelt found apparent females with male cells as well as ovaries, and apparent males with ova as well as testes. Hermaphroditism is frequent, and both ova and spermatozoa may develop at the same time in the same organ.

The author also describes the larva *Harpochaeta cingulata* g. et sp. n., apparently one of the Syllidæ, notable for the occurrence of hooked setæ, which are rare among Annelids.

**Chloragogen of *Ophelia radiata*.**†—Dr. Th. Schaeppi finds that the lymph cells of this Chætopod arise from the peritoneum which accompanies the branchial veins. Cells with and without rod-like concretions have the same origin; the chloragogen of the rods always arises around the nucleus and is secreted within vacuoles; the origin of the rod-form and the terminal growth of the rods depend on differences of tension in the walls of the vacuoles.

The vascular system of *Ophelia* is represented, in the abdominal

\* Tom. cit., pp. 224-89 (4 pls., 6 figs.).

† Jenaische Zeitschr. f. Naturwiss., xxviii. (1894) pp. 247-93 (4 pls.).



region, by a gut-sinus homologous with the dorsal vessel and by a ventral vessel; in the thoracic region, by a dorsal vessel and a gut-sinus homologous with the ventral vessel. The oxidation of the blood is effected posteriorly by the gills, anteriorly by the gut. The "cardiac body" is not a gland but a valve.

Where the peritoneum invests the abdominal intestine and the nephridia, it is a chloragogen-bearing connective tissue. In the intestinal epithelium there are chloragogen grains and granules differing in structure and chemical composition. They are especially abundant about the stomach and gullet.

The chloragogen of the peritoneum, of the nephridia, and of the connective tissue between the intestinal sinuses contains guanin. The chloragogen of the lymph-cells, blood-cells, and gut contains no guanin, but is chitinoid, and perhaps includes ferment as well. At any rate the term chloragogen is applied to concretions differing in physiological import and origin.

**Deep-sea Polychæta of Eastern Mediterranean.\***—Dr. E. von Marenzeller thinks that the twenty-five species of Polychætes dredged in deep water of the Mediterranean do not represent the whole Annelid-fauna, but rather afford an indication of the difficulty of obtaining them. Three new species:—*Pholoë dorsipapillata*, *Protula Marioni*, and *Vermilia agglutinata* are described. *Panthalis oerstedii*, which extends from the Scandinavian coasts to outside Gibraltar, the similarly high northern but also Madeiran *Apomatus globifer*, and the North American *Eunice floridana* are now known to enter the Mediterranean. Twelve species of Serpulidæ were collected.

**New Phreoryctes.†**—Prof. A. Giard describes a new species of this rare type of earthworms, which he found near Boulogne-sur-mer, and which he calls *P. endeka* as the setæ are not developed beyond the eleventh metamere. A short description is given of the new species, and a key is added by which the now five described species may be distinguished.

**Californian Eudrilidæ.‡**—Mr. G. Eisen has lately established a new genus of this family which he calls *Deltania*; under it he groups all species which would be referred to *Microscolex*, but for their having a deltoid arrangement of the ventral setæ surrounding the generative and especially the male pores. In California there are at least three species of the genus, all of which appear very sensitive to dryness and heat, and are difficult to find except from February to April, in the neighbourhood of San Francisco. Detailed descriptions are given of *D. elegans*, *D. Troyeri*, and *D. Benhami*, and a table shows their differences and their points of distinction from *D. Poultoni* and *D. dubia*. *Argilophilus* is a new genus which extends from California to British Columbia; its species are the most common of Californian earthworms, but to find them in summer it is necessary to dig down six feet or more, when they may be found encysted in a chamber of clay, where they pass the dry season. A very full account is given of the anatomy of this genus, which stands nearest

\* Denkschr. K. Akad. Wiss. Wien, lx. (1893) pp. 25-48 (4 pls.).

† Comptes Rendus, cxviii. (1894) pp. 811-4.

‡ Mem. Calif. Acad. Sci., ii. (1894) pp. 21-62 (18 pls.).



to *Plutellus*, but differs in having a ventrally imperfect clitellum, two pairs of sperm-funnels and of testes, a very large and coiled prostate, ventral papillæ, copulatory setæ, and a small typhlosole, as well as in other characters. Two kinds can be distinguished, but they do not appear to be specifically distinct, so that the author adopts the trinomial system of nomenclature, and calls one *A. marmoratus ornatus* and the other *A. m. papillifer*. This memoir is most profusely illustrated.

**Earthworms from the Congo.\***—Dr. R. Horst describes *Benhamia congica* sp. n. from the Upper Congo; it is closely allied to *B. Stuhlmanni* and *B. affinis* from the Zambesi, but a comparison with types of these species sent to the author by Dr. Michaelsen shows that there are distinctive external specific characters.

**Bifid Earthworm.†**—Mr. H. C. Williamson describes a bifid earthworm in which the two "tails" were of unequal size, and suggests that the smaller half was due to budding on a normal earthworm. A new question raised is whether the worm burrowed, and if so, how it effected its movements.

**Excretory System of Nephelis.‡**—Herr A. Graf has studied this in *Nephelis vulgaris (octocolata)*. It includes the nephridia and the chloragogen cells. The nephridium consists of terminal vesicle, gland, and ciliated funnel. Under the title chloragogen cells the author describes the botryoidal or vaso-fibrous tissue, the elements of which are disposed in dorsal strands and in the 42 blood-spaces which Jacquet calls ampullæ. In the former case the chloragogen cells are extravascular, in the latter intravascular. Kükenthal's observations on *Tubifex* are confirmed; the chloragogen cells of *Nephelis* are excretory lymph-cells. The relations between the nephridia and the hæmolympathic excretory system are twofold; the ciliated funnels convey the débris of chloragogen cells from the ampullæ to the exterior, and the chloragogen cells may fix themselves directly to the nephridial gland, and breaking up allow their waste-products to pass into the nephridia by osmosis. In young forms some rudimentary nephridia without internal or external connections occurred beside the pharynx.

**Leeches of the Iberian Peninsula.§**—Dr. R. Blanchard communicates what seems to be the first paper published on Iberian leeches. The list includes a dozen species:—*Pontobdella muricata* L., *Glossiphonia bioculata* Bergmann, *Gl. marginata* O. F. Müller, *Gl. sexoculata* Bergm., *Gl. algira* Moquin-Tandon (= *Batrachobdella Latastii* Vignieŕ), of which a particular discussion, *Placobdella catenigera* Moquin-Tandon, *Hirudo medicinalis*, *H. troctina*, *Limnatis nilotica* Savigny (= *Hæmopsis sanguisuga* Moquin-Tandon), with notes on its occurrence in man, *Nephelis octocolata* Bergm., and *Dina Blaisei* A. Blanchard.

**Leech-like Parasites of American Crayfishes.||**—Mr. J. Percy Moore describes four species of *Branchiobdella*, three of which—*B. illuminata*,

\* Tijdschr. Nederl. Dierk. Vereen., iv. (1894) pp. 68-70 (3 figs.).

† Ann. Mag., xiii. (1894) pp. 217-25 (1 pl.).

‡ Vierteljahrsschrift Naturf. Gesell. Zürich, xxxviii. (1893) pp. 354-60.

§ Ann. Soc. Españ. Hist. Nat., xxii. (1894) pp. 243-58 (6 figs.).

|| Proc. Philad. Acad., 1893, pp. 419-28 (1 pl.).

*B. pulcherrima*, and *B. instabilis*—are new. They agree with *B. philadelphica* (Leidy) and differ from the European species in having two pairs of vasa deferentia. It should be pointed out that the author is by no means certain that they should be placed in the genus to which he assigns them.

**Notes on Hirudinea.\***—Dr. R. Blanchard points out that *Nepheleis sexoculata* Schneider is really *N. octoculata*; he has shown that in Nephelids the eye may present various anomalies, among which the atrophy of the antero-lateral eyes is not rare. These anomalies are more common in certain localities, and it looks as if segregation had given rise to a special race.

The species described by Schneider as *N. scripturata* is to be referred to *N. atomaria* of Carena; it must not be forgotten that Leeches vary greatly in their coloration. *N. crassipunctata* Schneider is likewise *N. atomaria*.

#### β. Nemathelminthes.

**Notes on Gordii.†**—Prof. L. Camerano describes *Gordius Raphaelis* sp. n. from the Orthopterous genus *Phyllodromia* taken in the French Congo. He expresses the belief that a revision should be made of the American species referred to *G. verrucosus* Baird by Baird and by Örley; he has found the species in a Mantis from the French Congo. *G. varius* Leidy is probably not a distinct species, but a series of specimens are necessary to settle the question.

#### γ. Platyhelminthes.

**Developmental History of Nemertines.‡**—Dr. O. Bürger, in face of the very contradictory results of Hubrecht and Salensky, has made a revision of this subject. It is of importance to note that the Pilidium is made up of ectoderm, endoderm, and mesoderm. The germinal plate of the germinal discs consists, in its earliest stage, of two cell-layers—a high external cylinder epithelium, and an inner flattened epithelium; the former arises from the ectoderm of the larva, and the inner from the mesoderm or cells of the gelatinous substance of the Pilidium. Dr. Bürger confirms Hubrecht's statement that the proboscis is derived from a special invagination of the larval skin, and not from the head-discs.

The nephridia arise from hollow evaginations of the wall of the oesophagus which are laid down at the point where the wall of the pharynx passes into the subumbrellar surface of the Pilidium. The sacs which are pushed into the gelatinous mass fuse with the hinder germinal discs, and are completely cut off from the oesophagus. They become shut off from the outer world. A canal-system is developed from the saccular rudiments. The efferent duct of the nephridia does not correspond to their primitive orifice, but is a secondary invagination of the epithelium of the young Nemertine.

The blood-vessels are derived from a space (archihæmal cavity) which appears in the jelly (mesoderm) of the Pilidium after the conerescence of the anterior pair of discs, and, later on, it is further developed posteriorly.

\* Bull. Soc. Zool. France, xviii. (1893) pp. 194-8 (1 fig.).

† Tom. cit., pp. 213-6 (1 fig.).

‡ Ber. Naturf. Gesell. Freiburg i/B, viii. (1894) pp. 101-41 (1 pl.).

The cerebral organs are evaginated from the germinal plate of the hinder germinal discs at a time when these still form invaginations of the Pylidium-ectoderm open to the exterior. They are laid down in the form of hollow cones, and the cavity passes into the canal of the cerebral organs; both spaces communicate with the amniotic cavity during the embryonic life of the Nemertine. The cone bends backwards at its hinder end, and the bent part fuses with the straight. In this way the canal becomes curved, and the cerebral organ spherical in form. This organ never becomes completely separated from the hinder germinal plate.

The œsophagus of the Pylidium passes into the fore-gut of the Nemertine, while the mid-gut is formed from the endodermal sac.

**Polypostia similis.\***—Dr. D. Bergendal describes, under this name, a new Polyclad, which resembles the Leptoplanidæ, but is remarkable for the number of its male copulatory organs. Of these there are about twenty, and they completely surround the large female genital orifice. Of the male organs one is larger than the rest, and is placed more horizontally; each of them receives from large seminal canals a short vas deferens. At the hinder part of the body there are about fifty organs similar to the male copulatory apparatus, but they have no vasa deferentia. Mature females have not yet been detected.

This genus must be placed with *Cryptocelides* in a special family, which the author proposes to call the Polypostia[i]dæ. *Polypostia* is very probably an extremely primitive acotylar Polyclad, which gave rise to the Leptoplanidæ.

The discovery of this form is of great importance, as it affords support to the hypothesis of Lang that the male copulatory organs of Polyclads are derived from other organs by transformation of function.

**Distomum Westermanni in the United States.†**—Dr. H. B. Ward has found in the lungs of a cat a parasite which careful examination shows to be the Asiatic *D. Westermanni*. It is possible that it was introduced into the United States by the Chinese, but this much is certain, that the ova have found a host in which they can live; it is only to be hoped that it may prove to be a solitary case.

**Canal of Laurer.‡**—Mr. Seitaro Goto has made a comparative study of this enigmatic organ of Distomes, and has come to the conclusion that it, the blind sheath of *Amphilina*, and the genito-intestinal canal of ectoparasitic Trematodes are homologous structures; and that the vagina of the last corresponds to the uterus of *Amphilina*. As the latter is clearly homologous with the organ of the same name in *Bothriocephalus* and the Tæniidæ, it follows that the many-jointed Cestodes have no canal of Laurer at all.

**Adult Cestodes of Cattle, Sheep, and Allied Animals.§**—Dr. C. W. Stiles and Mr. A. Hassall have made a careful revision of the tapeworms

\* Rev. Biol. du Nord de la France, v. (1893) 3 pp. (separate copy). See also Fysiograf. Sällskapets Hdgr., 1892-3, Bl. 4.

† Centralbl. f. Bakteriöl. u. Parasitenk., xv. (1894) pp. 362-4.

‡ Op. cit., xiv. (1893) pp. 797-801 (4 figs.).

§ U.S. Dep. of Agriculture, Bureau of Animal Industry, Bulletin No. 4, Washington, 1893, 134 pp., 16 pls.

of cattle and their allies. *Moniezia planissima* sp. n., *M. Benedeni*, *M. Neumanni*, *M. expansa*, *M. oblongiceps* sp. n., *M. trigonophora* sp. n., *M. denticulata*, *M. alba*, *Thysmura actinioides*, and *T. Giardi* are described. The genus *Stilesia* proposed by Raillet for *Tænia globipunctata* and *T. centripunctata* is accepted. *Moniezia nullicollis*, *Tænia Vogti*, *T. crucigera*, *T. capreoli*, and *T. capreæ* are forms as to which further information is desirable.

It is remarkable that the life-history of not one of these tapeworms is known; for more than a year the authors have been making experiments, but have as yet only negative results to report. Experiments in feeding sheep directly with eggs have been without result, as have experiments in infecting various insects and earthworms. The authors are confident that cattle cannot become infected with tapeworms by swallowing their eggs.

**Cystic Worms of Bothriocephalus in German Fishes.\***—Prof. M. Braun states that the larval stage of the Broad Tape-worm has been observed by him in *Lota vulgaris*, which is sold in quantities at Königsberg in the winter and spring; they are particularly abundant in the pyloric appendages, and these, Schauinsland states, are, when slightly dried, used for the cure of pains in the stomach. Such a habit might well tend to human infection by this dangerous parasite.

#### 5. Incertæ Sedis.

**Notes on Rotifers.†**—Mr. F. R. Dixon-Nuttall gives an account of the male of *Copeus pachyurus*, and describes them as restless little fellows, very much like a young female in general outline.

Mr. J. Hood describes ‡ *Floscularia cucullata* sp. n., found in a marsh pool in Perthshire; it is most remarkable for the shape and structure of the corona, the large dorsal lobe calling to mind a monk's cowl, but the long sleeve-like processes of *F. Hoodi* are wanting. Three kinds of eggs were observed in the hyaline tubes which these animals inhabit. A male was seen and was found to have a prominent dorsal antenna, such as is known in the male of no other Floscule.

#### Echinoderma.

**Experimental Embryology illustrated by Echinoderms.§**—Herr C. Herbst continues his investigation on the effects of lithium salts on the development of sea-urchin embryos. To 97.5 ccm. of sea-water he adds 2.5 ccm. of 3.7 per cent. lithium chloride solution, and the result is a strange modification of development. As yet he has not succeeded in rearing "lithium larvæ" of other forms besides sea-urchins (*Sphaeræchinus granularis* and *Echinus microtuberculatus*); he tried ova of *Asterias glacialis* and of Ascidians without result.

Fertilized ova are placed in the sea-water, to which the lithium salt has been added. The first observed change is that the cells of the blastula-stage are more vacuolar than is normal. The blastula lasts

\* Centralbl. f. Bakteriöl. u. Parasitenk., xiv. (1893) pp. 801-4.

† Journ. Quek. Micr. Club, v. (1894) pp. 333 and 4 (1 pl.).

‡ Tom. cit., pp. 335-7 (1 pl.).

§ MT. Zool. Stat. Neapel, xi. (1893) pp. 136-220 (2 pls., 5 figs.).



longer than usual, and becomes elongated. It is succeeded by a form constricted in the middle into two vesicles—a thin “gastrula-wall portion” and a thick “enteron-portion,” which vary greatly in relative size. The constriction usually becomes complete, and by secondary growth a more or less narrow connecting portion is formed. The thick part frequently becomes divided into two. A ciliated band, homologous with that of the *Pluteus*, appears in varied form, and the development of the lithium larva ends. If less lithium be used, the type of larva which results is an exogastrula, i.e. with the endoderm part turned the wrong way, outwards instead of inwards, and it is this type which gives the key to the other. If the thick-walled vesicle correspond to endoderm, what takes place in many cases is a disproportionate growth of endoderm, in fact the series ends in a form in which the thin-walled vesicle (i.e. ectoderm) has disappeared. This remarkable form Herbst calls a holoentoblastia; it is distinguished in size, ciliation, structure and number of cells from an ordinary blastula or from Hertwig’s stereoblastulæ, which are filled up with mesenchyme cells. The chief results, then, are two, the process of “exogastrulation” and an increase in the archenteric or endoderm-forming zone which leads to the two-vesicled type.

Incompletely formed lithium larvæ, returned to ordinary sea-water, continue their abnormal development, but not unless they have as blastulæ remained 18–20 hours (at a temperature of 14–15° C.) in the lithium water. After a short stay in the lithium water the embryos may form a calcareous skeleton when returned to normal conditions. The effect of the lithium is less, the further advanced the stage at which the eggs come under its influence; indeed typical lithium larvæ are not certain to be formed unless the lithium has acted on the early segmentation stages. The first expression of the influence, however, is in the blastula, when the endoderm begins to be formed.

Another interesting result of a short stay in the lithium water is the displacement of the *Pluteus* outgrowths of the larva. They may of course be entirely inhibited, but if the calcareous needles are formed and show displacement, the *Pluteus* outgrowths arise under their stimulus from groups of ectoderm cells which do not normally form them. This is against the doctrine of specific areas. So is it also with the ciliated band. The cells which ought to form it, don’t, but take on the characters of endoderm cells. Therefore, against Roux and Weismann, the author maintains “idioplasmatic equivalence” of the cells in early stages.

The author concludes with asking what kind of organism the lithium larvæ would form if they grew up? Would it illustrate “saltatory evolution.” He points out, also, that each ovum has its individuality, each reacts differently, and the results form a graded series. Therefore the caution is suggested, that a gradual series of adults does not, in itself, prove continuous descent; “the series may have arisen because different individuals reacted in varying degrees to the same influences.”

Herr Hs. Driesch\* continues his investigation of the effect of artificial conditions on the development of sea-urchin eggs.

His first chapter is entitled “Exogastrula and Anenteria, or the influence of warmth on the development of Echinoid ova.” When blastulæ of *Sphærechinus granularis*, for about 26 hours after fertilization,

\* *MT. Zool. Stat. Neapel*, xi. (1893) pp. 221–54 (1 pl.).

are kept on a stove heated to about 30° C., the great majority show in about 18 hours the exogastrula state. The rudiment of the archenteron is turned outwards. There is, however, no such increase of the growing zone as Herbst describes.

Some 24 hours after exogastrulation, the larva assumes the familiar prismatic form, calcareous needles appear, the gut is divided into three parts, but these are not expanded. On the contrary they shrivel and an "Anenteria" larva, preceded by an "Anentoblastia" stage, results.

The second chapter is entitled "Variations in the formation of Micromeres, or the result of diluting the sea-water." Various degrees of dilution induce numerous variations in the formation of micromeres, and yet normal Plutei often resulted.

A third set of experiments concern the relations of ectoderm and endoderm. The micromeres were removed, cells of the "animal" and "vegetative" half remained, and a normal Pluteus was formed. From cells of the "vegetative" half alone (4-8) a normal gastrula developed, and likewise from cells of the "animal" half alone. Driesch therefore concludes that the micromeres are not essential, and that the formation of the two layers does not imply previous qualitative differences in the blastomeres.

Thus, according to Driesch, the cells of the segmented ovum are equivalent, and organogenesis is induced by differences of position and by external stimulus, acting on the self-differentiating plasma.

Dr. T. H. Morgan\* has made experiments on *Arbacia punctulata*, *Asterias Forbesi*, and on crossing *Arbacia* and *Asterias*, the one an Echinoid, the other an Asteroid. With regard to normal cleavage the author made the interesting observation that as early as the two-cell stage the protoplasm of the *Arbacia*-egg is not isotropic, as the micromere area is already foreshadowed. The details of various experiments are given, but their interest is shadowed by the author's conviction that he has succeeded in fertilizing the eggs of *Asterias* with the sperm of *Arbacia*.

Deep-Sea Echinoderms of Eastern Mediterranean.† — Dr. E. v. Marenzeller reports that twenty-six species have been collected. As in other cases it is found that species supposed to be more or less littoral extend to considerable depths; thus *Astropecten pentacanthus* was taken at 629 metres, *Palmipes membranaceus* from 400-600 metres, *Spatangus purpureus* at 620, and *Synapta digitata* at 629 metres. Some of the dredged species were known only from the Atlantic, like *Echinus norvegicus* or *Holothuria intestinalis*. Others are described for the first time, and of these *Gnathaster* [*Odontaster*] *mediterraneus* and *Kolga ludwigi* are perhaps the most interesting. The high temperature of the water of the Mediterranean appears to be the cause of the general absence of deep-sea Holothurians, most of which are inhabitants of cold water. At certain points the extreme outposts of the littoral forms mix with the species proper to deep waters. The author expresses the belief that improved methods of dredging will reveal the presence of at present undiscovered species.

\* Anat. Anzeig., ix. (1893) pp. 141-52 (4 figs.).

† Denkschr. K. Akad. Wiss. Wien, lx. (1893) pp. 1-24 (4 pls.).

*Luidia paucispina*[is] sp. n., has only five arms; *Pentagonaster hystricis* is, among other points, distinguished from *P. granularis* by the possession of pedicellariæ. *Asteropsis capreensis* of Gasco is shown to be a *Marginaster*. Eighty-three examples of *Echinus norwegicus* were taken. *Pseudostichopus occultatus* was taken at a number of stations. The form of the calcareous ring and its joints is used to arrange the decachirote Elpidiinae, thus:

- (A) Joints more or less closely connected.
  - (a) All arms and joints undivided—*Elpidia glacialis*, *Irpa*.
  - (b) The arms of the anterior cross divided—*Kolga*.
- (B) Joints not connected.
  - (a) All arms of the joints undivided—*Scotoplanes*.
  - (b) (?) All arms divided—*Elpidia* (except *E. glacialis*), *Par-elpidia*, *Peniagone*, and ? *Scotoanassa*.

Echinoderms of the Bay of Amboyna.\*—M. P. de Loriol has an interesting notice of the specimens collected by MM. Pictet and Bedot; perhaps the most important form found was *Asthenosoma varium* which came from comparatively shallow water, and the young of which, if correctly determined, have a test that is not at all elastic. *Ophiopezella luetkeni* is a new species which tends to show that *Ophiopezella* is a good genus. *Ophiactis Brocki* is allied to *O. modesta* from the same locality; but reasons are given for distinguishing it. *Ophiocnida Picteti* is described from a single specimen. *Ophiothrix Bedoti* and *O. Picteti* swell the list of species of this genus. An account of the Crinoids is promised later.

Ophiuroids of Mauritius.†—M. Paul de Loriol devotes the third part of his "Catalogue raisonné" of the Echinoderms of this island to the Ophiuroids. He finds 29 species, 12 of which are here described for the first time. It is considered that Ljungman's genus *Ophiopezella* should be retained, and a new species *O. dubiosa* is placed in it. Twelve specimens show that the specific characteristics of *Pectinura venusta* sp. n. are very constant; it stands nearest *P. ramsayi*. *Ophiarachna* has two new species, *O. Robillardi*, named in honour of the deceased collector, on whom M. de Loriol depended for his specimens, and *O. mauritiensis*, which is near *O. incrassata*. In *Ophiarthrum lymani* sp. n. we have the third species of this genus. A comparatively large number of new species are added to the already more than unwieldy *Ophiothrix*; these are called *mauritiensis*, *Robillardi*, *lepidus*, *fallax*, *picturatus*, and *tristis*; Robillard is again commemorated in *Ophiomyxa*.

The only Crinoid M. de Loriol knows from Mauritius is *Antedon carinata*, which is already known to have an exceedingly wide range.

Rhizocrinus Santagatai.‡—Sig. G. Capellini has made a careful study of this form, which Meneghini included among the Crinoids, and in regard to which there has been some controversy. He has convinced himself that it is identical with the Foraminifer *Bathysiphon filiformis* Sars, as Andreæ maintained, and with *B. taurinensis* Sacco.

\* Rev. Suisse Zool., i. (1893) pp. 359-426 (3 pls.).

† Mem. Soc. Phys. Genève., xxxii. I. No. 3 (1894) 64 pp., 3 pls.

‡ Atti R. Accad. Lincei (Rend.), 1894, pp. 211-8.



## Cœlentera.

**Digestion of Cœlentera.\***—M. Marcellin Chapeau finds that in the Siphonophora digestion appears to be exclusively intracellular. In Actiniæ there is also a secretion of fluids capable of dissociating albuminoid bodies, and very slowly peptonizing them; the fluid in the cavity is more alkaline than sea-water, and is able to emulsify fatty substances. The intracellular action rapidly peptonizes albuminoids, and produces the saponification of fats and the dissolution of starch. The intracellular action is to be considered as preparatory to the final and principal process of digestion which is realized within the phagocytoclements of Actinians. The reduction of the food into fine particles makes it possible for the cells to ingest them. All the cells of the gastrovascular cavity seem to take part in the intracellular digestion.

The digestion of Actinians may be considered as a stage in physiological evolution; below them there is only intracellular digestion; in them a new function begins which, in higher forms, becomes very perfect.

**Minyadæ.†**—Mr. O. Carlgren has some notes on these pelagic Actinians. In a form whose external appearance recalled Bell's description of *Minyas torpedo* a peculiar arrangement of the septa was observed; each pair of septa ordinarily consists of a complete and an incomplete one; and has on its outer side a well-developed pad of longitudinal muscles, and on the inner the more feebly developed transverse muscles. Four pairs, however, form an exception to this rule; in these the longitudinal muscles occupy the same position in both septa of a pair. The author thinks that this arrangement may be explained by supposing that the Minyadæ are descended from a ten-rayed Hexactinian in which there has been an enlargement of the entosepta (*Binnenfächer*) and a diminution of the exosepta (*Zwischenfächer*). It would be a matter of interest to examine the arrangement of the septa in young forms.

With regard to the systematic position of the group the author does not share the inclination of McMurrich or of Haddon and Shackleton to place the Minyadæ with the ordinary Actiniæ (Hexactiniæ). He thinks it would be better to attach weight to the arrangement of their septa, and to their peculiar pneumatic apparatus, and to form for them a special tribe of Minyæ; this, however, he abstains for the present from characterizing.

**Alyconaria of the Albatross.‡**—Prof. T. Studer has a preliminary notice of the Alyconaria collected by the 'Albatross' in the Pacific. Only thirty-four species were collected, but of these fifteen were the only forms already described. The new forms are *Clavularia gregaria*, *Voeringia pacifica*, *Pennatula alata*, which is about 90 mm. long, *P. Koellikeri*, which is as much as 300 mm. long, and is a magnificent form, *Stachyptilum superbum*, *Kophobelemnon affine*, which is very near *K. stelliferum*, *Umbellula geniculata*, *Cladiscus Agassizii*, a fine species nearly 300 mm. high, *Distichoptilum Verrilli*, allied to *D. gracile*, *Anthothela argentea*, very near *A. grandiflora*, *Dasyggorgia fruticosa*,

\* Arch. Zool. Expér., i. (1893) pp. 139-60.

† Öfv. K. Vet. Akad. Förh., li. (1894) pp. 19-24.

‡ Bull. Mus. Comp. Zool., xxv. (1894) pp. 53-69.



*Lepidisis Verrilli*, which must be a fine growth when complete, a magnificent *Calyptrophora* (*C. Agassizii*), *Stachyodes ambigua*, the richly branching *Stenella ramosa*, *Amphilophis abietina*, allied to *A. regularis*, *Acanthogorgia brevispina*, *Psammogorgia variabilis*, and *Callistephanus Wrightii*. Some of the known forms, such as *Pennatula phosphorea* and *Umbellula eucrinus* are inhabitants of the Atlantic.

**Hydroids of the Albatross.\***—Mr. S. F. Clarke has a report on the ten Hydroids collected by the 'Albatross' off the west coast of Central America. *Obelia castellata* sp. n. may, when its manner of reproduction is known, prove to be a *Campanularia*; it has, however, many points of agreement with *O. gelatinosa*. *Lictorella geniculata* sp. n. has a very rigid, angulate habit. The new *Halecium argenteum* is allied to *H. macrocephalum*. *Sertularia variabilis* sp. n. sometimes has the stems monosiphonic throughout, while others are polysiphonic except at the extremities.

**Minute Anatomy of Limnocodium.†**—Mr. R. T. Günther makes some additions to our knowledge of the minute anatomy of this interesting freshwater Medusa. He finds that the descriptions of Allman and of Ray Lankester apply only to the younger and smaller tentacles, and that the older and larger are always hollow throughout their length; in many sections the lumen of the tentacles was found to be directly continuous with the lumen of the ring-canal. Morphologically, then, the tentacles of *Limnocodium* are hollow tentacles, though it is quite possible that, under certain circumstances, they often contract to such an extent that the lumen vanishes; indeed, at the bases of the ectodermal cells there is a powerful circular muscular coat. Lankester's account of the velar sense-organs is confirmed in every particular. The author was able to make some observations on the development of the spermatozoa, and to prove the correctness of de Varenne's statement that "Dans toute la durée du développement des spermatozoides, en prenant la cellule mère dès son début, le noyau n'a pas changé."

With regard to the systematic position of this jelly-fish, Mr. Günther remarks that it appears to be a case in which an increase of knowledge is correlated with an increase of difficulties; to include *Limnocodium* in the Trachomedusæ is to make that group more unnatural than it is at present; it is perhaps best to say of it that it is a Medusa descended from Leptomedusan ancestors which has developed sense-organs with an endodermal axis independently of the Trachomedusæ.

**Freshwater Medusa from the Niger.‡**—M. J. de Guerne has a notice of a letter from Dr. Tautain, who reports that in January 1888, he found, near Bamakou, on the Niger, a freshwater Medusa of which he collected about 50 specimens; these he unfortunately failed in successfully preserving. The attention of better equipped travellers should be called to this statement.

**Perigonimus.§**—Messrs. H. L. Osborn and C. W. Hargitt describe a supposed new species of this Hydroid from Long Island, which they pro-

\* Bull. Mus. Comp. Zool., xxv. (1894) pp. 71-7 (5 pls.).

† Quart. Journ. Micr. Sci., xxxv. (1894) pp. 539-50 (1 pl.).

‡ Bull. Soc. Zool. France, xviii. (1893) pp. 225-30.

§ Amer. Natural., xxviii. (1894) pp. 27-34 (12 figs.).

pose to call *P. Jonesi*. They point out that its interest is due to the many primitive characters united in it. It seems not unlikely that the higher calyculate Campanularian Hydroids have descended from athecate ancestors, more or less like *Perigonimus*; though a "naked hydroid," it has a covering, and that such a one as an animal like a hydroid might have in the earlier stages of the acquisition of a strong skeleton. It is not a highly differentiated product, but a delicate slightly compacted slime, though very unlike the mucous secretions that all animals are so commonly throwing off from their bodies. If a semi-fluid coat of this sort were stiffened only a little, we should, the authors say, arrive at the more compact chitinous cuticle of the calyculate forms. It is urged that the differences between the gelatinous and the chitinous cuticle are such differences in the chemical or metabolic functions of cells as could conceivably come within the range of the operation of natural selection.

#### Porifera.

**Hexactinellid Spicules.\***—Prof. F. E. Schulze discusses the derivation of the very varied and often complex Hexactinellid spicules from the regular hexactine or triaxial type. This is particularly difficult where more than six rays arise from the centre, but in 1887 Schulze showed how these forms might be due to a deep cleavage of one or more of the main rays of an original hexaster. Still more difficult are the eight-rayed discostasters of certain species of *Acanthascus* and *Rhabdocalyptus*. Schulze's ingenious interpretation is that each of the main rays of an original hexaster divided into four, and that these coalesced in threes, thus resulting in an apparent octaster. He also discusses the peculiar pearl-like spherules occurring in *Pheronema giganteum*.

**New Sponges.†**—Mr. E. Topsent has had his researches at Roscoff and Banyuls rewarded by the discovery of several Sponges, some of which are new to the localities, and others quite new to science. From Roscoff there come, of the latter, *Bubaris constellata* and *B. gallica*; *Pocillon* and *Batzella* are suggested as new genera for *Myxilla (Pocillon) implicita* and *Halichondria inops* respectively. The new species from Banyuls are *Dendrilla cirsioides*, *Darwinella intermedia*, *Halisarca sputum*, *Reniera parietalis*, *R. flavescens*, *R. fulva*, *Gellius Lacazei*, *Stylorella Marsillii*, *Myxilla versicolor*, *Stylostichon fibulatus*, *Pilochrota Mediterranea*, and *Stelletta stellata*. *Prosuberites* is a new genus of delicate Clavulida with no microscleres instituted for *P. longispina [is]*, and *P. rugosus* spp. nn. A fuller account is given of a new generic type which the author calls *Desmanthus*, a representative of a new family—the Desmanthidæ—of the Hoplophora trianosa, than was possible in 1889. The sponge-fauna of Banyuls is remarkable for its wealth in Hexaceratina.

#### Protozoa.

**So-called Excretory Granules of Infusorians.‡**—Dr. W. Schewiakoff has studied the doubly refractive granules or crystals which occur freely

\* SB. K. Preuss. Akad. Wiss., 1893, pp. 991-7.

† Arch. Zool. Expér. et Gén., i. (1893) pp. xxxiii.-xliii.

‡ Zeitschr. f. wiss. Zool., lvii. (1893) pp. 32-56 (1 pl.).

in the endoplasm or in special vacuoles of ciliated Infusorians and some other Protozoa. His researches relate chiefly to *Paramœcium*. The bodies consist for the most part of calcium and phosphoric acid, perhaps along with some organic substance in combination with calcium phosphate. It seems likely that they are dissolved in plasmic fluids and excreted through the contractile vacuoles.

**Food-vacuoles of Infusoria.\***—Miss M. Greenwood discusses the constitution and mode of formation of food-vacuoles in Infusoria, as illustrated by the history of the processes of digestion in *Carchesium polypinum*. As a result of feeding experiments she finds that the solid particles become gathered to a cluster with a rapid centripetal movement; those which are more peripheral leave the boundaries of the vacuole, and a composite solid mass lies in clear fluid surroundings. This process she calls aggregation, and proceeds to consider by what force it has been effected. The most probable explanation is that the solid particles which undergo change of position in aggregation are dragged together by the comparatively rapid retraction of some substance contained in the vacuole; this substance is probably viscous. The aggregated spherical ingesta join through the endoplasm of *Carchesium* for a variable time. Solution appears to be capricious, so far that all nutrient ingesta present are not of necessity digested synchronously. When it does set in, however, certain features of the process are invariable; it is effected in a fluid medium, but is rarely complete; innutritious remains travel with varying rapidity towards the anal ridge, whence they are discharged. Other things being equal the intracellular sojourn of ingesta tends to vary directly with their digestibility; masses of carmine or Indian ink are got rid of comparatively soon. It is suggested that the process of aggregation will be found to be "an expression of obscure histological change bound up with the digestion of food, or more nearly with its preparation for digestion."

**Reproduction of Foraminifera.†**—Herr F. Schaudinn, from the study of reproduction in a large number of Foraminifera, comes to the conclusion that it is effected by division of the protoplasm into a number of pieces which secrete the test, and grow up in the way that is characteristic of the proper species. To this general statement some modifications must be made.

(1) The division of the protoplasm, the form taken by the parts, and the secretion of the test are effected within the maternal test. The embryos leave this test by the mouth (*Ammodiscus*) or, if that is too narrow, by breaking down the test (*Discorbina*).

(2) The division of the protoplasm is effected within the test, but the shaping of the form and the secretion of the new one are effected outside it; that is, the parts leave the maternal test as naked plasmodia (*Calcituba*).

(3) Division, shaping, and test-formation are all effected outside the maternal test; that is, after the protoplasm of the mother has left its test as a connected mass (*Miliolina*).

Before reproduction the mother-animal is always multinuclear, the

\* Proc. Roy. Soc. Lond., liv. (1894) pp. 466-72.

† Biol. Centralbl., xiv. (1894) pp. 161-6.



young are generally uninuclear, but in some cases there are two or three or even many nuclei.

So far as the author has been able to show there is never a division of the nucleus into two, but it, after having gone through a series of changes, breaks up into a number of daughter-nuclei.

**Foraminifera of the Gazelle.\***—Dr. J. G. Egger has a monograph of the Foraminifera collected during the voyage of the German corvette 'Gazelle' in the years 1874–6. Four hundred and ninety-three species are enumerated, of which forty-four are new. The late Mr. H. B. Brady's 'Challenger' Report has, very properly, been taken as the basis, and the author appears to have much the same wide view as to the limits of species as was taken by the accomplished English student.

**Index to Foraminifera.†**—Mr. C. Davies Sherborn has issued the first part of an index to the genera and species of Foraminifera, the character of which may be judged by the following quotation:—

“BDELLOIDINA, Carter, 1877. Carter, Ann. Mag. Nat. Hist. [4] xix., 1877, 201; Brady, Report Challenger, 1884, 319.

—AGGREGATA, Carter. Ann. Mag. Nat. Hist. [4] xix., 1877, 201, xiii., 1–8.

— — — — Brady, Report Challenger, 1884, 319, xxxvi., 4–6.”

Indices of this kind are of the greatest value to specialists, and as Mr. Sherborn is known to be a careful and accomplished bibliographer, we feel sure we may recommend the index under notice to the many workers at the Microscope who are interested in the Foraminifera.

**Irritability of Noctiluca.‡**—M. J. Massart finds that this phosphorescent animalcule is sensitive to a slight agitation of the water, as, indeed, most of us have observed, to sudden variations in the temperature and density of the water, and to a number of chemical substances. Experiment showed that the agitation of the water produces a deformation of the body of the *Noctiluca*, and it is this deformation which causes the phosphorescence. Even under artificial conditions the creature responds more readily to stimuli at night than in the daytime.

**Amœbæ and their Cultivation.§**—Prof. A. Celli and Dr. R. Fiocca state that they have succeeded in cultivating *Amœbæ* on a specially devised medium, and communicate some of the observations they have made during the past two years. All *Amœbæ* exhibit two phases, the amœboid and cystic. In the latter the *Amœbæ* consist of granular contents and an investment, the inner surface of which is smooth and circular, and the outer smooth or wavy. In the amœboid phase may be distinguished more or less granular contents (endoplasm) and an external hyaline substance (ectoplasm). In the endoplasm a vesicular nucleus is constantly visible, and often vacuoles of variable number. In

\* Abh. Bayer. Ak. Wiss., xviii. 2 (1893) pp. 195–458 (21 pls.). Cf. Ann. and Mag. Nat. Hist., xiii. (1894) pp. 368–70.

† 'Smithsonian Miscellaneous Contributions 856. An Index to the Genera and Species of the Foraminifera. Part I. A to NON,' City of Washington, 1893 [received April 1894], 8vo, ii. and 240 pp.

‡ Bull. Sci. de la France et de Belgique, xxv. (1893). See Amer. Natural., xxviii. (1894) pp. 270 and 1.

§ Centralbl. f. Bakteriol. u. Parasitenk., xv. (1894) pp. 470–3.



the amoeboid stage the *Amœbæ* exhibit movements effected either by the whole mass, or by means of processes. They incorporate solid particles such as bacteria, spores, and red corpuscles. The only observed method of reproduction was by division. Spore-formation was never detected. The contents of the cystic form become granular, a crack appears in the cyst wall; through this the contents escape and two young *Amœbæ* are formed. This process was watched in hanging-drop cultivations, and lasted from 24 to 72 hours. Both forms were able to survive a temperature of 0°–15° for a considerable period, while 45° was soon fatal in the amoeboid stage and 60° in the encysted. To sunlight and drying they were more resistant, while to antiseptics and acids their resistance is slight. They were better able to withstand alkalies, e. g. 4·5 ccm. of carbonate of soda in 10 ccm. of the cultivation medium. Hence alkalinity of the medium is a necessity for their cultivation, though absolute purity was never obtained by either chemical or mechanical means. Further communications are promised.

**Interrelations of Myxosporidia.\***—M. P. Thélohan, recalling the fact that there are some Myxosporidia which develop only two spores, asks whether they should be regarded as the primitive type, and answers the question in the affirmative. Not only do they exhibit the highest organization, but in the more degraded the number of spores is greater, and those that live in tissues have an enormous number of them. An exaggeration in the number of reproductive bodies is, as is well known, one of the most constant attributes of parasitism.

**Development of *Coccidium oviforme* in Bile-duct of Rabbits.†**—Herr W. Podwysoszky has determined that when the young *Coccidium* or spore penetrates an epithelial cell of a bile-duct a vacuole appears to be formed in the cell plasma. In this hollow there is neither albuminous nor mucous fluid. Once within, the spore loses its spindle or fish-like form and becomes a spherical homogeneous little mass of protoplasm, the nucleus of which appears as a clear vesicle with a dark-staining nucleolus. As the *Coccidium* grows larger, its protoplasm becomes more granular. Young intracellular *Coccidia* are possessed of a crescentiform body of unknown import and previously undescribed. This body the author suggests is of a decidual nature, and is not observable in the adult condition. The process of spore-formation is marked by extraordinary polymorphism, the size and number of these fish-like spores appearing to be directly associated with the size of the adult and conditions of space. Infection of the liver cells was once observed, and in these cells the vacuoles were found to contain mucus, and the *Coccidia* seemed able to retain their spindle shape, which is never the case in the epithelial cells of the bile-ducts. In both, i. e. in the hepatic and bile-duct cells, the presence of *Coccidia* leads to flattening and compression of the cell nucleus, the cell itself being greatly distended, and finally disappearing from atrophy.

**Parasite of Skin Cancer.‡**—Prof. M. Kurloff describes a cancer parasite which has much resemblance to the *Rhopalocephalus carcinoma-*

\* Comptes Rendus, cxviii. (1894) pp. 428–30.

† Centralbl. f. Bakteriol. u. Parasitenk., xv. (1894) pp. 481–5.

‡ Tom. cit., pp. 341–9 (1 pl., 9 figs.).

*tosus* Korotneff.\* The new parasites, found mostly in the centre of epithelioma nests, are of variable size and shape. They are sometimes round, sometimes elongated, and frequently irregular, and occasionally give off lateral branches. When small they lie in the cell protoplasm, and as they become larger pseudopodial processes are extended which may stretch for some distance and even penetrate other cells. The parasite appears to lie in a vacuole, for a clear space between its outline and the cell plasma is clearly distinguishable. In the larger, older forms one, two, or three nuclei are discernible; these are faintly granular bodies, and stain more strongly than the rest of the protoplasm; they do not contain chromatin threads or nucleoli. In some of the parasites a dark brown pigment could be perceived.

The author is convinced of the parasitic nature of these bodies, and states that they are easily seen under medium powers ( $\times 300-400$ ) and can be made out without staining the preparations if these have been hardened in a fluid containing osmic acid, as then they assume a dark brown hue.

The specimens were hardened in Flemming's fluid and the sections stained in various ways, e.g. borax-ammonia-alum and picrocarmin, hæmatoxylin, safranin, methyl-violet, &c. The most successful preparations were treated with safranin and afterwards with picric acid-alcohol.

**Cancer Parasite.**†—Herr Sawtschenko considers that the reason why some observers deny the presence of Sporozoa in carcinoma, is due to confusion between true Sporozoa and appearances having a superficial resemblance thereto. He holds that the round intracellular bodies, apparently invested with a capsule and exhibiting metachromatism, are non-parasitic cell inclusions, and that certain colour reactions are merely indicative of mucin and not of Sporozoa. Yet there is a close connection, for the formation of the mucous vacuole is brought about by the penetration of Sporozoa into the cell plasma, the parasite not unfrequently being found in the vacuole, though the vacuole may contain only mucin.

The author states that both plasma and nucleus of parasitic Sporozoa are stainable at all stages of development with anilin dyes, and have the same staining reaction as the tissue cells of the tumour. With magenta-red for example the mucin is metachromatized to violet, while the nucleus of the parasites and of the cancer cells is coloured red. In size the parasite is usually very small, and in its amœboid form is spheroidal or oval, with deeply staining nucleus and finely granular protoplasm. Propagation takes place after the manner common to Gregarinæ and Coccidia, and the spores when fully formed are spindle-shaped or fish-like. The number of spores is variable, and when they have penetrated into the cell plasma they may either assume the characters of the adult parasite or retain for some time the pyriform shape. Both the embryonic and amœboid forms are mobile and may wander from one cell to another and leave behind as legacy large vacuoles filled with mucus.

The author has never observed an encapsuled parasite, which if they

\* See this Journal, 1893, p. 649.

† Centralbl. f. Bakteriol. u. Parasitenk., xv. (1894) pp. 485-7.

were Coccidia must have been the case, and he therefore regards them as amœbo-sporidia.

**Influence of Cold on Vitality of Malaria Parasites.\***—Dr. N. Sakharoff finds that the malaria parasite can retain its vitality for about a week, though exposed to a freezing temperature. The parasites were obtained by cutting off and freezing the limbs of birds, and also by leeching men suffering from malaria. The leeches were then packed in ice. In the latter instance a drop of blood was squeezed out daily and the leech replaced in ice. The non-pigmented plasmodia were found to have preserved their mobility. In dried preparations of this blood stained with a mixture of methylen-blue and eosin the nucleus of the parasite was completely demonstrated.

The author inoculated himself with the blood of one of these leeches, and twelve days after the symptoms of malaria declared themselves. In the blood a very small number of parasites were found; these were non-pigmented, circular, nucleated bodies, identical in appearance with those of the original source.

Further observations from a case of double tertian ague, in which all forms of the parasite were present, led to the conclusion that the younger forms of the malaria parasite are more resistant to cold than the older and larger.

The author's observations on preparations stained with methylen-blue and eosin indicate that the flagellate forms are the result of influences affecting the nucleus, the chromatic filaments becoming split up, and thus forming the flagella. The general conclusion drawn from this is that the degree of sensitiveness depends on the complexity of the nuclear structure and on the chromatin of the nucleus, because in the course of development the nuclear structure becomes more complicated and mitosis occurs, while in the younger stages the chromatin is condensed into a compact little mass.

**Hæmatozoa of Birds.†**—Dr. N. Sakharoff inquires into the nature of the flagellate bodies, regarded as independent organisms (malarial parasites) by Laveran, as Infusorians (*Polimitus*) by Danilewsky, as abnormal forms by Grassi and Felletti, as stages in the development of hæmatozoa by Canalis. By following the history of the Hæmatozoa and their nuclear changes, Sakharoff has convinced himself that the flagellate bodies are the disrupted and liberated chromatin filaments of moribund Hæmatozoa.

He goes on to discuss the "leucocytozoaires" described by Danilewsky—colourless, slightly granular, nucleated spheres or spindles which may give rise to flagellate bodies, and which the discoverer regarded as intracellular stages in the development of *Polimitus*. In ravens, Sakharoff finds that these parasites destroy the nuclei of the leucocytes; they are karyophagous. In rooks they occur in cells with normal nuclei, and there are several within one leucocyte. They destroy the leucocyte, but leave the nuclei intact. Young forms and spores are most frequent in lymphocytes and hæmatoblasts, whose phagocytic properties are insufficient to destroy them. The spores are oval or fusiform bodies; as they

\* Centrabl. f. Bakteriöl. u. Parasitenk., xv. (1894) pp. 158-62.

† Ann. Inst. Pasteur, vii. (1893) pp. 801-11 (1 pl.).

grow their nucleus loses its definiteness, in the large forms it disappears, and this is a symptom of the parasite's degeneration.

**Hæmatozoa in Animals.\***—Herr W. Danilewsky calls attention to the extensive distribution of some Flagellata and Sporozoa in the blood of Vertebrata, and more especially to the resemblance between the Hæmatozoa of birds and man. In both cases the parasite would seem to belong to the same zoological group (genus as well as species), for the similarity in structure, in biological characters, and in general appearance is very great, and besides this the author has been able to demonstrate that an acute malarial infection occurs in birds, and that this disease is brought about by Cytamœbæ, parasitic in the red corpuscles, which sporulate in the same way that they do in man (rosette form). The author would explain some unimportant differences between the Hæmacytozoa of avian and human malaria by taking into consideration the modifying effect of the blood, regarding this as a cultivation medium. Besides this the virulence of the microbes and the resistance of the organism must also be taken into consideration. Taking all the circumstances and appearances together the author is inclined to regard malaria infection of Vertebrata as a sporozoosis.

\* Centralbl. f. Bakteriol. u. Parasitenk., xv. (1894) pp. 480-1.





## BOTANY.

A. GENERAL, including the Anatomy and Physiology  
of the Phanerogamia.

## a. Anatomy.

## (1) Cell-structure and Protoplasm.

**Aggregation of Protoplasm.**—Dr. P. Klemm\* urges further objections against the application of the term “active albumin” to the precipitations caused in living cells by the action of coffeeine or other alkaloids, or of ammonia or ammonium salts, on the protoplasm of the living cell. He considers it probable, either that the aggregated substance and the albumen of living protoplasm are different bodies, or that the silver reaction is not an infallible diagnostic for the hypothetical active albumen.

As the result of observations on very thin sections, Dr. Klemm adduces further arguments against Bokorny's view that the aggregation-precipitates produced in this way in the hypodermal cells of Crassulaceæ take place in the parietal utricle of protoplasm; he states that they are located exclusively in the cell-sap.

Dr. T. Bokorny replies,† especially on the second of these two points, basing his arguments on observations made on the living cell rather than on microscopic sections.

**Physodes.**‡—Herr E. Crato records the result of further observations on these structures, which he regards as an essential constituent of living cells. The protoplasm has always a reticulate structure, the size of the meshes varying greatly; sometimes they are comparatively large, as in *Cladophora*, sometimes visible only under the highest powers of the Microscope. In the lamellæ which separate these meshes are imbedded the nucleus, the chromatophores, and the physodes; and the spaces are filled up by a hyaline fluid which he calls the “chamber-fluid,” comprising the cell-sap and the enchylema. The physodes, to which most of the microsomes belong, serve especially for the transport of assimilable substances; they contain the most readily oxidizable substances of the cell, and travel periodically between the nucleus and the periphery of the cell. This movement is independent of the streaming of the protoplasm.

The author has investigated these structures, especially in the brown algæ (Fucaceæ and Phæophyceæ), where they are of almost constant occurrence. They occur also abundantly in the hairs and in the green cells of many flowering plants. Their size varies greatly, even within the same cell. The physodes almost invariably contain substances allied to phenol, especially phloroglucin. Their micro-chemical reactions are given in great detail. The author has come to the conclusion that neither the physodes nor the lamellæ of the reticulate protoplasmic framework contain albumen; the staining reactions from which its presence has been concluded are due to substances allied to phenol.

\* Bot. Centralbl., lvii. (1894) pp. 193-9, 225-9 (2 pls.). Cf. this Journal, 1893, p. 345.

† Tom. cit., pp. 270-2.

‡ Bot. Ztg., li. (1893) 1<sup>te</sup> Abtheil., pp. 157-96. Cf. this Journal, 1893, p. 58.

**Plasomes.\***—Mr. A. Schneider confirms the observation of Wiesner with respect to the occurrence of plasomes in the living cell, in the case of the palisade-cells in the root-tubercles of *Cycas revoluta*. These plasomes were capable of being introduced into other cells by inoculation. They develop into dermatosomes outside the living cell, although they do not divide under these circumstances. As soon as all plasomes capable of growth have reached maturity, apparent reproduction ceases. Further illustrations were afforded by the tuber of the potato and the root of maize.

**Nucleoles and Centrosomes in Psilotum.†**—Herr G. Karsten calls attention to the behaviour of the nucleoles during the division of the nucleus in the sporanges of *Psilotum triquetrum*. They occur both in the tapetal cells and in the sporogenous tissue, having a more elongated shape in the former, more spherical in the latter. In the resting condition of the nucleus these nucleoles always occupy a peripheral situation; shortly before division takes place they emerge from the accompanying chromosomes into the surrounding protoplasm, assuming the form of sharply defined red-stained spheres. The number of nucleoles which emerge is very rarely more than two, one from each side of the nucleus. These appear to be the points at which the separating elements of the nucleus are formed. They move each to one pole of the nuclear spindle, and there divide at the time when the chromosomes break up into two longitudinal halves. From the time of their entrance into the protoplasm they behave precisely in the same way as centrosomes; the author proposes for them the term "nucleo-centrosomes." He thinks that they are, in all probability, identical with the bodies described by Strasburger as being thrown off in the division of the nucleus, which he terms secretion-bodies.

**Formation of Cell-walls.‡**—M. E. de Wildeman contests Zimmermann's theory of the mode of formation of septa in cells, and maintains that the membranes are at first semi-fluid, but rapidly become solid.

**Waviness of the Cell-wall of the Exoderm of Roots.§**—Herr A. Rimpach finds that the radial cell-walls of the exoderm of roots are, in both Monocotyledons and Dicotyledons, frequently wavy in a similar way to those of the endoderm, though in a slightly different manner, which is described in detail. The author has proved by experiment that this waviness is caused, not by any peculiarity in the internal structure of the cell-wall, but by the contraction of the root, as is also the case with the endoderm.

(2) Other Cell-contents (including Secretions).

**Enzymes.||**—Sigg. C. Fermi and L. Pernossi record the results of their observations on the action of enzymes under various conditions. Most of the experiments were made with pepsin and trypsin, though

\* Bull. Torrey Bot. Club, xx. (1893) pp. 379-83.

† Ber. Deutsch. Bot. Gesell., xi. (1893) pp. 555-62 (1 pl.).

‡ Atti Congr. Bot. Internaz. Genova, 1892 (1893) pp. 308-13. See Bot. Centralbl., lvii. (1894) p. 209.

§ Ber. Deutsch. Bot. Gesell., xi. (1893) pp. 467-72. Cf. this Journal, 1893, p. 652.

|| Centralbl. f. Bakteriol. u. Parasitenk., xv. (1894) pp. 229-34.

ptyalin, diastase, and emulsin were also used. The points they directed their attention to were:—the effect of temperature; the action of sunlight, of gases, and of various chemicals; the effect of filtration and dialysis; the mutual action of ferments; their fate within the organism; and lastly, their supposed poisonous properties. Contrary to the opinion of all preceding writers, the authors state that the enzymes are not poisonous, even when 2 grm. are injected daily for a week, and they state that the poisonous effect attributed to enzymes must have been due to the presence of microbes.

**Localization of the Active Principles of the Cucurbitaceæ.\***—M. L. Braemer finds the bryonin of *Bryonia dioica*, the colocynthin of *Citrullus Colocynthis*, and the elaterin of *Ecbalium Elaterium*, located in special elements which have the form of tubes arranged in straight or curved rows, and situated chiefly in the periphery of the liber, the pericycle, and the cortical and fundamental parenchyme. They differ altogether from normal sieve-tubes, and more nearly resemble laticiferous tubes of the septated type.

**Localization of Nicotine in the Tobacco-plant.†**—Dr. G. B. De Toni has investigated the occurrence of nicotine in *Nicotiana Tabacum* and other species of the genus. The alkaloid does not occur in the seeds nor in the very young plant. In the root of the mature plant it is found in the cortical tissue. In the aerial organs—branches, leaf-stalk, lamina, calyx, corolla—it is chiefly localized in the epiderm, and especially in the basal cells of the hairs. It was not found in the mesophyll or assimilating tissue of the leaf. The author does not regard nicotine as having any defensive function; it appears to be an excretory product, the result of a process of deoxidation. The various micro-chemical reactions are given.

**Fatigue-substances.‡**—By the name “fatigue-substances” (*Ermüdungsstoffe*) Herr F. Reintzer proposes to designate those bodies which are thrown off from the plant, and which act in a restraining or poisonous manner on its own life. With the Schizomycetes and Saccharomycetes these substances often entirely prevent the further growth of the organism from which they are thrown off. But in the higher plants they are generally found in special receptacles separated from the living tissue by impermeable walls. Here they may serve a secondary and useful purpose in the life of the plant, by shielding it from the attacks of enemies which would otherwise destroy it.

### (3) Structure of Tissues.

**Perimedullary Zone.§**—As the *perimedullary* || zone of the stem M. L. Flot defines the peripheral region of that portion of the inner tissue which is bounded outwardly by the protoxylem. When the vascular bundles are not united by a continuous cambium ring, this zone is visible only on the inside of the bundle. In this case it either remains

\* Comptes Rendus, cxvii. (1893) pp. 753-4.

† Atti R. Ist. Veneto, iv. (1893) pp. 1736-44.

‡ Ber. Deutsch. Bot. Gesell., xi. (1893) pp. 532-7.

§ Ann. Sci. Nat. (Bot.), xviii. (1893) pp. 37-112 (4 pls.).

|| *Rectius*, circummedullary.

parenchymatous or becomes sclerenchymatous. But when, as is the case with most Dicotyledons, there is an unbroken cambium ring which forms secondary xylem and phloem, the perimedullary zone is developed in various ways. It may either remain unligified, or the inner part only, or the outer part only, may be lignified; or it may consist entirely of cellulose; or it may become completely lignified. In all cases the cells of the perimedullary zone are longer than those of the pith. They may become the seat of new formations. At the apex of the vascular bundle a meristem may be formed that either undergoes no further differentiation, or produces bundles of sieve-tubes and vessels. The formation of the internal phloem of bicollateral bundles is due to this zone. The inner is therefore always a later formation than the outer phloem.

The special development of the perimedullary zone is described in a large number of species, woody and herbaceous, belonging to various natural orders, mostly dicotyledonous.

**Flexibility of the Stem of Climbing Plants.\***—Herr H. Schenk discusses the cause of the greater flexibility of the stem of climbing shrubs as compared with those which do not twine. The species specially examined were *Aristolochia tomentosa*, *Olematis Vitalba*, *Wistaria chinensis*, and *Periploca græca*. The last shows a normal growth, while the other three present the peculiarity of the new formation of successive layers of cambium forming xylem and phloem, outside the original normal cambium. In the first two species named the xylem is composed of detached plates separated by thin-walled parenchyme, the layers of cambium and the sieve-bundles being still in close connection at the periphery.

**Structure of Thymeleaceæ and Peneaceæ.†**—From an examination of the histological characters of a large number of genera and species belonging to these two natural orders, M. P. van Tieghem concludes that the Thymeleaceæ should be placed among the Dialeptalæ with inferior ovary, near to the Combretaceæ, and that the Peneaceæ belong also to the same group, but show the greatest affinity to the Melastomaceæ. The Thymeleaceæ are divided into three sub-orders—the Drapeteæ, Thymeleæ, and Aquilarieæ. In the genera *Enkleia* and *Stephanodaphne* (Thymeleæ), and *Lophostoma* (Aquilarieæ), the cortical cells of the leaf contain remarkable filiform sclerites, which branch in all directions, ending beneath the epiderm, mostly between this layer and the palisade cells of the upper surface.

**Anatomy of Galegeæ.‡**—According to Herr J. Weylandt, the most marked characteristic of this tribe of Papilionaceæ is that the stomates are almost invariably surrounded by several bounding-cells arranged irregularly round the guard-cells. Tannin-sacs occur, as in the other tribes, containing not only tannin but also albumen.

**Anatomy of Ataccia.§**—M. C. Queva describes the anatomical structure of the stem and root of *Ataccia cristata* (Tacciaceæ). The stem

\* Flora, lxxvii. (1893) pp. 313-26 (2 pls.).

† Ann. Sci. Nat. (Bot.), xvii. (1893) pp. 185-294 (1 pl.).

‡ 'Beitr. z. anatom. Charakt. d. Galegeen,' München, 1893. See Bot. Centralbl., lvi. (1893) p. 33.

§ Comptes Rendus, cxvii. (1893) pp. 409-12.



contains a massive axial vascular cylinder, the anterior bundles of which are foliar. The axillary bud is inserted on the three or five foliar bundles nearest to the surface of the leaf and on the outermost peripheral bundles of the stem.

**Anatomy of the Stem of *Wistaria sinensis*.**\*—According to M. Lecercler du Sablon, the peculiarity in the structure of the stem of this plant consists in the occurrence of a supernumerary generating fibro-vascular layer in the internal portion of the cortex. *Wistaria* presents, in this respect, a resemblance to certain Menispermaceæ.

#### (4) Structure of Organs.

**Divisibility of Organs.**†—Dr. C. Reehinger finds that fragments of potato of a cubic measurement of 4 cm. taken from the interior of a tuber can put out adventitious shoots; the production of the growing point proceeding from the cambium-cells of the vascular bundle. In the root of the horse-radish the limit of divisibility was found in discs 1.5 mm. thick, and consisting of twenty-one rows of cells; the new organs were formed exogenously in the callus. A distinct polarity was determined in a callus containing chlorophyll formed at the end of pieces of root of the dandelion 15–20 cm. in length, and in pieces of the root of lucern 6–7 cm. long and 0.75 cm. thick. The callus may perform four different functions, viz.:—(1) The healing of wounds; (2) the nutrition of the organs formed from it; (3) assimilation; and (4) as a connecting tissue between the old tissue and the new organs.

**Spurs of *Tropæolum* and *Pelargonium*.**‡—M. P. Vuillemin gives an exhaustive account of a variety of modifications which occur in the form and structure of the spur of the corolla in these genera; and draws the general conclusion that they are nearly allied to one another, and that they present relationships with the polysymmetrical Geraniaceæ on one hand and with the Sapindaceæ on the other hand.

**Fruetification of *Juniperus*.**§—Mr. J. G. Jack states that, in America, the fruit of *Juniperus communis* does not mature until the autumn of the third year after flowering; while, of the two other American species of that genus, *J. virginiana* requires only one year, and *J. Sabina* var. *procumbens* two years, to mature. By the end of the second autumn the galbuli of *J. communis* have attained to three-fourths or four-fifths of their ultimate size; the seeds are filled with soft milky endosperm. In the third spring and summer the endosperm grows firm and solid, and by the autumn of the third year the fruit is fully ripe.

**Fruit of *Bennettites*.**||—M. O. Lignier describes in detail the fruit of *Bennettites Morierei* (formerly known as *Williamsonia Morierei*), which he considers fully establishes the separation of the Bennettiteæ as an independent family of Gymnosperms distinct from the Cycadeæ.

He further describes a remarkable transformation of the epiderm of

\* Rev. Gén. de Bot. (Bonnier), v. (1893) pp. 474–9 (1 pl.).

† Abhandl. Zool.-Bot. Gesell. Wien, xliii. (1893) pp. 310–34.

‡ Journ. de Bot. (Morot), vii. (1893) pp. 377–82, 409–16 (1 pl.).

§ Bot. Gazette, xviii. (1893) pp. 369–75 (1 pl.).

|| Comptes Rendus, cxvii. (1893) pp. 867–9; cxviii. (1894) pp. 158–9.

the atrophied seminiferous peduncles into an envelope of dissociated tubes.

**Navel of the Apophyse of the Fruit-scales of *Pinus*.**\*—Dr. L. Celakovsky has followed the development of this structure in the sections *Pinaster* and *Strobus* of *Pinus*; and finds therein a fresh argument against the theory of Sachs and Eichler that the fruit-scale is an excrescence on the inner side of the bract, which latter organ they regard as a true carpel.

**Pitchered Insectivorous Plants.**†—Dr. J. M. Macfarlane describes in detail the adaptations for insect-catching in various species of *Nepenthes*, *Sarracenia*, *Darlingtonia*, and *Heliamphora*. From the structure both of the vegetative and of the reproductive organs he considers the Sarraceniaceæ and the Nepenthaceæ to be much more nearly allied to one another than has hitherto been supposed, and proposes to unite them together into a single natural order which he names ASCIDIACEÆ. The general morphology and histology of the flowers in the four genera are also described, and the arrangements for pollination. In the structure of the flowers, *Sarracenia* and *Darlingtonia* exhibit a very close resemblance, while *Heliamphora* differs widely. The pitchers of *Nepenthes* are frequented by running insects, while those of the Sarraceniaceæ are practically visited only by flying insects. In a rather small pitcher of *N. Hookeri* as many as seventy-three cockroaches were caught within a fortnight.

Dr. Macfarlane replies to the criticisms on his previous paper by Bower,‡ and to some of the conclusions of Goebel, as to the morphology of the pitchers in these plants.

**Vegetative Branching.**§—Herr L. Koch has made a large number of observations on flowering plants—trees, shrubs, climbing plants, aquatic plants, herbaceous perennial, and annual plants—for the purpose of determining the following points:—Whether the vegetative shoot is to be regarded as a derivative from the growing point; the relationship of the leaf to the shoot; and whether there are histological differences between these two.

The author confines the term growing-point to that portion of the apex of the shoot which still consists of embryonal tissue. Hanstein's plerome is simply the pith in process of formation. The axillary shoot arises partly from a superficial comparatively small portion of embryonal, partly from a deeper already differentiated tissue. While the growing point of the primary axis displays a marked differentiation of the young internodes, this is not the case with the axillary bud. Cases occur in which the primary growing-point breaks up into two unequal portions. In other cases the branching takes place lower down in the primary axis, without the growing-point taking any direct share in it. Nearly all axillary shoots of trees and shrubs arise from masses of embryonal tissue which are only indirectly derived from the growing-point.

There is only a marked difference between plants with decussate and those

\* Oesterr. Bot. Zeitschr., xliii. (1893) pp. 314-6 (6 figs.).

† Ann. Bot., vii. (1893) pp. 403-58 (3 pls.). Cf. this Journal, 1889, p. 779.

‡ Cf. this Journal, 1890, p. 480.

§ Jahrb. f. wiss. Bot. (Pringsheim), xxv. (1893) pp. 380-488 (8 pls.).

with spiral phyllotaxis; in the former the growing-point is usually flat; in the latter it is more or less conical; the axillary buds are far more highly developed in the latter case than in the former.

**Stem of Grasses.\***—With respect to the comparative anatomy of their stem, Herr F. Hohenauer classifies grasses into three groups, viz.:—(1) With solid stem; this includes only a few species, e. g. *Zea Mays*, *Saccharum officinarum*; (2) an intermediate type, e. g. *Bambusa stricta*; and (3) with hollow stem. This last group includes by far the largest number of species, which may again be divided into those in which the strengthening sheath is continuous, and those in which it is interrupted.

In most grasses the stomates are arranged in rows, and present the appearance of having four guard-cells. A strengthening sheath is always present, and its cells are often lignified. Assimilating tissue sometimes occurs between this sclerenchymatous ring and the epiderm. The vascular bundles are always enclosed in a sheath, which is often lignified. The phloem always occupies the outer part of the bundle; the vessels are annular, spiral, or pitted. The distribution of the bundles on a transverse section varies in different species.

**Knees of Taxodium distichum.†**—Dr. J. P. Lotsy describes the formation and histological structure of the remarkable processes which grow from the roots of this tree only when growing in swampy situations. Morphologically the knee is a limited local hypertrophy on the upper side of the curve of a root springing from the base of the stem and running near the surface of the soil. When young the cells of the knee contain abundance of the spores of a fungus probably belonging to the Ustilagineæ. The author was unable to come to any definite conclusion as to the function of these structures.

**Blind Root-suckers of Swamp-forests.‡**—Mr. R. L. Heinig describes the contrivances by which the trees which constitute the forests in a swampy portion of the Ganges Delta are enabled to resist the uprooting effects of storms. One of the most important of these is the development of blind root-suckers, which are found in species of *Avicennia*, *Sonneratia*, and other genera, and especially in *Heritiera fomes*. They are woody processes, growing in an upward direction, and developed at irregular distances along the whole course of the roots. They project from 1 to 3 feet above the surface of the ground, and apparently cease to grow when the apex has reached the level of the highest spring tides. They are destitute of buds, and are incapable of producing them; but are abundantly supplied with cavities for the aeration of the root.

**Succulent Compositæ.§**—Herr J. Müller describes the peculiarities of the structure of a number of species of succulent Compositæ, chiefly belonging to the genera *Kleinia*, *Sonchus*, *Senecio*, and *Othonna*, the succulence being manifested sometimes in the stem, sometimes in the

\* Abhandl. Zool.-bot. Gesell. Wien, xliii. (1893) pp. 552-68.

† Studies Biol. Lab. Johns-Hopkins Univ., v. (1893) pp. 269-77 (2 pls. and 3 figs.). Cf. this Journal, 1890, p. 626.

‡ Journ. Asiatic Soc. Bengal, lxii. (1893) pp. 158-61 (1 pl.).

§ 'Beitr. z. Anat. holziger u. succulenter Compositen,' Berlin, 1893, 42 pp. and 4 pls. See Bot. Centralbl., lvii. (1894) p. 53.



leaves. The strong development of latex-tubes favours the supposition that these structures perform the function of retaining water in the tissues. In *Sonchus* the latex-tubes occur, not, as in other genera, by the side of the phloem-bundles, but in the cortex and pith of the stem. This genus again differs from the others in the absence of sclerenchymatous elements. Sphero-crystals are formed in many species by treatment with alcohol, or on drying; they usually consist of inulin, sometimes of calcium phosphate. Crystals of calcium oxalate are widely distributed. The author finds that, as a general rule, morphological differences are correlated with differences in histological structure.

**Anatomy of Maize.\***—Dr. J. W. Harshberger gives a brief description of the anatomy of *Zea Mays*, together with a detailed account of its origin, distribution, cultivation, and uses.

**Leaves of Nymphaeaceæ.†**—Dr. F. Brand points out that our European water-lilies have three distinct kinds of leaf, an aquatic (submerged), a floating, and an aerial form. The primordial leaves of the seedling are aquatic, long, narrow, folded and shortly stalked, and with a thin epiderm. In *Nuphar luteum* the greater number of the leaves are aquatic, the production of floating leaves being limited to the warmest portion of the year; the minimum [temperature for their formation appears to be about 10° R. (12·5° C.). The aquatic leaves have a much longer length of life than the floating, and are the most important in their biological functions. A well-developed floating leaf has, however, about three and a half times the weight of the best developed aquatic leaf. The aerial leaves, which are formed especially in shallow water, resemble the floating leaves, except in the absence of a palisade layer. In *Nymphaea alba* the aquatic leaves have a shorter term of life and play a less important part in the biology of the plant. Aerial leaves are more frequent than in *Nuphar*.

**Leaf of Butomaceæ.‡**—M. C. Sauvageau describes the structure of the leaf of the four genera belonging to this natural order of aquatic Monocotyledons:—*Lymnocharis*, *Hydrocleis*, *Tenagocharis*, and *Butomus*. The last-named genus differs from the other three in having equitant leaves; in the complete absence of laticiferous vessels, and of an apical opening to the leaf; and in the presence of spiral fibres in the vicinity of the vascular bundles.

**Fall of Leaves.§**—Herr R. v. Ihering adduces several instances of trees belonging to the tropical and subtropical zone of Brazil which lose their leaves when growing in moist, but are evergreen in dry situations. He gives his opinion that the evolution of species with deciduous leaves took place only in the Tertiary period.

**Stipules of Euonymus.||**—Herr L. Linsbauer has studied the structure and development of the minute deciduous stipules which occur in several species of *Euonymus*, and probably in all the Celastraceæ.

\* Contrib. Bot. Labor. Univ. Pennsylvania, i. (1893) pp. 75-202 (4 pls.). †

† SB. Bot. Ver. München, Jan. 8, 1894. See Bot. Centralbl., lvii. (1894) p. 168.

‡ Ann. Sci. Nat., xvii. (1893) pp. 295-326 (9 figs.). Cf. this Journal, 1892, p. 63.

§ Atti Congr. Bot. Internaz. Genova, 1892 (1893) pp. 247-59. See Bot. Centralbl., lvii. (1893) p. 50.

|| Oesterr. Bot. Zeitschr., xliii. (1893) pp. 301-5, 340-6 (1 pl.).



Although occupying the position of leaf-structures, they are of purely epidermal origin, and consist entirely of parenchymatous cells without any vascular elements. These organs present therefore a further illustration of transitional structures intermediate between phyllomes and trichomes. They also occur on the bud-scales, and are apparently in all cases functionless.

**Pearl-glands.**—According to Prof. O. Penzig,\* these structures vary in their morphological value in different instances. In the Piperaceæ and Begoniaceæ they are trichomic, in the Ampelideæ they are emergences. Their structure in the case of the grape-vine is described in detail. The epiderm of the gland is usually furnished with a stomate. The cells contain drops of oil and small granules of starch and proteinnaceous substances. They appear to furnish food for Acari.

Dr. A. Nestler † describes the structure of the remarkable spherical glands which, under certain conditions, produce a pearl-like appearance on all the aerial organs of *Artanthe cordifolia*. They are simply protuberances from special epidermal cells. Within them were found protoplasmic threads and a fatty oil.

**Achenial Hairs of Compositæ.**‡—Miss M. A. Nichols has examined the structure of the hairs on the achene of a large number of American Compositæ. She finds two types of hair, which do not closely correspond to the established lines of group division, viz.:—(1) a simple pointed hair having apparently no median line or division-wall; (2) a compound or double hair, branching so as to form a double-pointed apex.

**Hairs of *Tilia argentea*.**§—Herr von Widenmann points out a remarkable connection between the hairy covering of the leaves of the silver lime and the production of fruit. The purpose of this covering seems to be the protection of the leaves in their pendent position, which is necessary in order to allow a sufficient access of air and light to the flowers to permit of the development of the fruit.

**Classification of Tubers.**||—M. D. Clos proposes a classification of tubers into four classes, viz.:—(1) Germination-tubers (present in the earliest stage of the plant); (2) Gemmation tubers (formed at a later period); (3) Pseudorhizal tubers (formed on adventitious roots); (4) Tubers of the ascending axis. The first two classes are again divided into a number of sub-classes. A list is also given of the species of Leguminosæ on which the root-tubers have been observed.

### β. Physiology.

#### (1) Reproduction and Embryology.

**Embryo-sac of *Acer rubrum*.**¶—Mr. D. M. Mottier has followed out the development of the embryo-sac in this tree, and finds that it presents

\* Atti Congr. Bot. Internaz. Genova, 1892 (1893) pp. 237-45 (1 pl.). See Bot. Centralbl., lvii. (1894) p. 76.

† Oesterr. Bot. Zeitschr., xliii. (1893) pp. 333-5, 386-90 (1 pl.).

‡ Bot. Gazette, xviii. (1893) pp. 378-82 (1 pl.).

§ J. Heft. Ver. Vaterl. Naturk. Württemberg, xlix. (1893) 6 pp. and 1 pl. See Bot. Centralbl., lvii. (1894) p. 141.

|| Mém. Acad. Sci. Toulouse, v. (1893) pp. 381-405.

¶ Bot. Gazette, xviii. (1893) pp. 375-7 (1 pl.).

no special peculiarities. The mother-cell of the embryo-sac is a single cell, probably originally hypodermal, in the apex of the nucellus. The position of the endosperm-nucleus varies greatly; it may be close to the egg-apparatus, or more nearly midway between the two ends. The antipodals are absorbed soon after the maturity of the embryo-sac. The pollen-grains formed in the anthers of female flowers develop normally, though they never become functional.

**Nucellus of the Ovule of Croton.\***—Herr G. Kayser states that, in *Croton flavens* var. *balsamifer*, the ovule is dichlamydeous, not monochlamydeous as previously described, the caruncle being developed from the outer integument. The nucellus curves slightly, and passes through both the endostome and the exostome, projecting through the micropyle as a long sausage-shaped protuberance, with a wrinkled slightly papillose surface, which curves behind the caruncle, reaching to the axis of the ovary. After impregnation the projecting portion of the nucellus becomes cut off by the constriction of the micropyle, and the portion enclosed within the integuments is completely absorbed by the embryo-sac.

**Influence of the Pollen on the Fruit and Seed.†**—Dr. E. Giltay offers a contribution to the settlement of the question whether the pollen can have any direct influence on the impregnated embryo or on the fertilized plant outside the embryo; from the result of experiments on varieties of peas and of rye. He finds, in the one case, the colour of the cotyledons, and in the other that of the aleurone-layer of the seed, to correspond with that of the male parent, and therefore to have been directly influenced by the pollen-grain.

**Fertilization of Gymnosperms.‡**—Dr. L. Jurányi corrects a misapprehension of Strasburger § as shown in a sentence in his last work on the fertilization of Gymnosperms. Jurányi has never stated that the division of the nucleus in the pollen-grain of *Ceratozamia* takes place without any longitudinal splitting of the nuclear filaments.

(2) Nutrition and Growth (including Germination, and Movements of Fluids).

**Distribution of Seeds of the Cyperaceæ.||**—Herr C. Raunkiaer states that the transport of the seeds of most species of Cyperaceæ is effected by the agency of water. In many paludose species of *Carex* the fruit is heavier than water, and is buoyed up by a floating apparatus.

**Germination of Dormant Seeds.¶**—According to observations made by Herr A. Peter, seeds of about 70 species of plants which must have lain dormant in the ground for periods varying between 20 and 46 years, germinated when the soil was loosened, moistened, and exposed to light, although the germinating processes were carried on with less energy than in fresh seeds.

\* Ber. Deutsch. Bot. Gesell. xi. (1893) Gen.-Versamml.-Heft, pp. 61-5.

† Jahrb. f. wiss. Bot. (Pringsheim), xxv. (1893) pp. 489-509 (1 pl.).

‡ SB. K. Ungar. Naturwiss. Gesell. Budapest, Nov. 8, 1893. See Bot. Centralbl., lvii. (1894) p. 232.

§ Cf. this Journal, 1893, p. 655.

|| Bot. Tidskr., xviii. (1893) pp. 19-23. See Bot. Centralbl., lvii. (1894) p. 207.

¶ Nachr. K. Gesell. Wiss. Göttingen, 1893, pp. 673-91.

**Rapidity of Growth.\***—Herr F. Benecke has measured the rate of growth of the leaf-sheath of *Musa sapientum* in Java in May. He found the most rapid growth to be between 7·40 and 7·45 a.m., when the increase was at the rate of 1·1 mm. per minute. This is higher than any rate of growth recorded by Pfitzer, except in the case of the filaments of *Triticum*.

**Relation between Tension and Growth in Length.†**—By experiments on a considerable number of woody and herbaceous plants, Prof. S. Schwendener and Herr G. Krabbe have tested the correctness of Sachs's and de Vries's theory that the growth in length in any organ is a factor of the degree of tension in the cells which compose it. Their results are in all cases unfavourable to this conclusion. The observations were made on roots, internodes of stems, leaf-stalks, and flower-stalks. They find that the growth of an organ may vary greatly with the same turgor-tension; in the cases where the increase in length is distributed over a large space, there is neither any zone of maximum growth nor any zone of maximum turgor-tension. Not unfrequently zones of rapid growth have a low degree of turgor-tension, and *vice versa*. The growth in length of an organ is dependent on other factors which have much more influence than the degree of turgor-tension, such as the production of the formative substances, their adaptation for the formation of the cell-wall, their chemical transformations, &c.

**Periods of Growth and Causes of Development.‡**—Prof. J. Sachs argues that a large number of morphological facts may be correlated and explained by a methodical study of the phases of the growth of the plant in relation to the external causes of or incitives to development (*Bildungsreize*). It must be regarded as an axiom that every new organ is a product of those already in existence.

Four phases of growth may—somewhat roughly and arbitrarily—be distinguished in any organ; its embryonal condition; its emergence from the growing point; its growth in length; and its maturity. The first two may be regarded especially as morphological, the last two as physiologico-biological periods. The third period is the one in which the organ is especially sensitive to influences of a purely mechanical nature,—light, gravitation, pressure, contact, &c.; the fourth is characterized by the activity of chemical processes in the cell-walls.

Some help is given to arriving at a true theory of growth by a study of the phenomena of abnormalities. It is during the embryonal condition that the substances of which the flowers are formed travel from the leaves to the rudimentary floral organs; and abnormalities may result from some of these molecules taking a wrong way in their distribution through the microscopically small organs; or arriving too late or too soon. The highly organized and differentiated forms of galls resulting from the punctures of insects are also very instructive in this respect.

**Growth of the Fruit of Cucurbita.§**—Mr. F. Darwin has made a number of observations on the rate of growth of the fruit of various

\* Ber. Deutsch. Bot. Gesell., xi. (1893) pp. 473-6 (2 figs.).

† Jahrb. f. wiss. Bot. (Pringsheim), xxv. (1893) pp. 323-69.

‡ Flora, lxxvii. (1893) pp. 217-53. § Ann. Bot., vii. (1893) pp. 459-87 (2 pls.).



species of *Cucurbita*. The following are his more important conclusions. Increase in size or in weight is either continuous, or is interrupted by periods of loss in weight or shrinkage in diameter. Both increase and decrease may take place at the rate of 0.1 gm. per minute in weight, and of 0.01 mm. per minute in diameter. Variations in the rate of growth are chiefly dependent on the hygrometric condition of the atmosphere, increased humidity causing increased growth, and *vice versa*. Changes in the amount of light have but little effect. Syringing the leaves and watering the soil cause a rapid increase in growth. The curve of growth shows a minimum in the afternoon, followed by a rapid rise towards evening, and this is followed by a fall as the night proceeds. The rate of growth is more uniform by night than by day.

**Metastasis and Respiration in Germinating Tubers and Seeds.\***—Herr E. Ziegenbein records the results of a series of experiments on germinating potatoes and seeds of *Lupinus luteus* and *Vicia Faba*, from which he derives the following conclusions. Free oxygen is not necessary for the breaking up of protoplasm in the living plant; nor is light necessary for the same purpose in the potato. Variations of temperature up to 30° C. have no effect upon the rapidity of germination; a still higher temperature (42°–43.5°) acts prejudicially on germination. The optimum temperature for respiration varies, for different plants, between 35° and 40°. The production of carbon dioxide goes on at temperatures below the freezing-point.

**Transpiration of Succulent Plants.†**—Dr. F. Noll describes an experiment by which he demonstrates the relation between the transpiration of a typical succulent (*Echinocactus*) and a typical non-succulent plant (leaf of *Aristolochia Siphon*). Comparing similar weights, the transpiring surface is 300 times greater in the latter than in the former case. Taking now *Opuntia* instead of *Echinocactus*, it was found that, for a unit of surface, the amount of transpiration was 17 times greater in the herbaceous than in the succulent plant. It follows that, for the same weight of substance, the amount of transpiration is 5100 times greater in a thin-leaved than in a succulent plant.

### (3) Irritability.

**Irritability.‡**—Prof. W. Pfeffer defines irritability as the phenomena produced by the “release” (*Auslösung*) process following after any impact. He regards the faculty as a fundamental property of all living organisms, whether animal or vegetable. The most recent researches in this department of physiology are referred to in detail. The sensitiveness of bacteria and of the antherozoids of ferns and mosses is so delicate, that the trillionth part of a milligram, say of malic acid, or of sugar of milk, will exercise a sensible attractive force.

**Geotropism and Epinasty.§**—Dr. F. Noll describes a modification of the clinostat by means of which he has determined that the strong median curvature which takes place in the flower-stalk of dorsiventral

\* Jahrb. f. wiss. Bot. (Pringsheim), xxv. (1893) pp. 563–606.

† Flora, lxxvii. (1893) pp. 353–6.

‡ Verhandl. Gesell. Deutsch. Naturf. u. Aerzte, 1893, 31 pp. See Arch. Sci. Phys. et Nat., xxx. (1893) p. 397.

§ Flora, lxxvii. (1893) pp. 357–62 (1 fig.).



flowers (*Aconitum*, *Dictamnus*, *Delphinium*) is the result of geotropism only without the co-operation of epinasty. The slight natural curvature of the upper portion of the stalk is, on the other hand, due to epinasty.

**Intertwining of Tendrils.\***—In opposition to the statement of Darwin, Mr. D. T. McDougal finds that the tendrils of *Micrampelis echinata* (*Echinocystis lobata*) display no lack of sensitiveness of contact to tendrils of the same plant as contrasted with foreign bodies. In this respect this species agrees with other climbing plants, which have not developed the contact sensitiveness in such a manner as to be able to distinguish portions of their own or of an allied plant from foreign objects.

**Heliotropism of the Mallow.†**—Prof. B. D. Halsted states that in the two common American mallows, *Malva borealis* and *rotundifolia*, the leaves are heliotropic. In the morning, if the day is clear, the leaves are placed with their upper surface at right angles to the rays of the sun, and, by slowly turning, this position is maintained throughout the day. The leaves of *Gossypium* are also heliotropic.

#### (4) Chemical Changes (including Respiration and Fermentation).

**Food of Green Plants.‡**—Reviewing the results of recent researches on the chemical processes which take place during the nutrition of plants, Mr. C. R. Barnes proposes to classify these processes under three heads, viz.:—(1) *Photo-syntax*, or the synthesis of carbon compounds out of carbon dioxide in the presence of chlorophyll, under the action of light: (2) Digestion, or the chemical change and solution of the solid foods; this is due in large measure, perhaps entirely, to the action of alterative enzymes: (3) Assimilation, or the conversion of the food into the living or mechanical substances of the plant tissues for repair of waste and growth. The author adopts the view that complex carbon compounds arise by condensation of formic aldehyde, and that these substances need not necessarily pass through the condition of starch.

**Causes of the Disappearance of Reserve Food-materials from Seeds.§**—According to Prof. W. Pfeffer, experiments carried on by B. Hansteen show that the transformation of starch into sugar in the endosperm is largely dependent on the rapidity with which the glucose is carried away. The presence of diastase is not essential to this transformation, although the scutellum has the power of producing this secretion. The mucilage-layer takes no part in the process. The absorption of reserve-cellulose and the disappearance of proteinaceous substances are effected in the same way as the transformation of starch.

**Respiration of Green and Etiolated Leaves.||**—As the result of a series of experiments made chiefly on *Vicia Faba*, *Lupinus luteus*, and *Triticum vulgare*, M. W. Palladine states that, if etiolated leaves are rich in carbohydrates, they develop well; but if not, they remain in a rudimentary condition, notwithstanding that they may contain a large

\* Bot. Gazette, xviii. (1893) pp. 396-7. Cf. this Journal, 1893, p. 660.

† Bull. Torrey Bot. Club, xx. (1893) pp. 489-90.

‡ Bot. Gazette, xviii. (1893) pp. 403-11.

§ Ber. K. Sächs. Gesell. Wiss., 1893, pp. 421-8.

|| Rev. Gén. de Bot. (Bonnier), v. (1893) pp. 449-73.

quantity of proteinaceous matters. Light is essential to the growth of green plants because it brings about conditions favourable to the greatest activity of the proteinaceous substances which they contain; it causes, by the promotion of transpiration, a flow of water from the root, and consequently a continuous supply of carbohydrates and mineral substances. It has no influence on the changes in the nature of the proteinaceous substances.

**Formation of Resins and Essential Oils.\***—Herr A. Tschirch states that resins or ethers are the principal constituents even of many solid hairs. Saponification produces aromatic acids, and a peculiar group of alcohols to which the author gives the name resin-alcohols or resinols. The resins and essential oils are not simply excreta, but perform a biological function for the plant. The formation of resin does not take place in the epiderm of the secreting organ, but in the wall of special greatly swollen cells which faces the secreting canal, and in a particular mucilaginous portion of the wall.

**Formation of Starch in *Pelargonium zonale*.†**—According to Dr. C. Acqua this plant belongs to the class in which the chloroplasts form starch-grains derived from substances already assimilated, or, in other words, in which the chloroplasts may be transformed into leucoplasts or starch-formers. But, although at first the starch-grains are developed entirely from the leucoplasts, a layer of cytoplasm soon takes part in the process, and subsequently continues exclusively the formative process. Layers of protoplasm are thus transformed into layers of starch. The microsomes in the protoplasmic layer are probably the first to initiate the transformation; they separate themselves from the hyaline protoplasm, and thus give rise to the formation of two distinct zones, which produce successively two layers of starch possessing different degrees of refrangibility. Hence the striated appearance of the layers of starch.

**Alkaline Reaction of Aquatic Plants.‡**—Dr. O. Loew has investigated the cause of the alkaline reaction of the water in which aquatic plants (*Elodea*, *Chara*) are growing vigorously. He determined that it is not due, as has been suggested, to the formation and excretion by the plant of an alkaline carbonate; but either to the separation of an organic calcium salt, or to the passing of the calcium carbonate excreted by the leaves into a colloidal condition, in which it is dissolved by organic substances.

#### γ. General.

**Vegetable Heat.§**—M. G. Bonnier states, as the result of a series of observations on the heat evolved by generating seeds and by opening flowers, that the rise of temperature is by no means necessarily the result of the production of carbon dioxide; it may be produced by the oxidation of other substances than carbon, or by doubling, or by hydration. This last is a very important source of heat, which has commonly been neglected. There are two maximum periods of the evolution of heat,

\* Jahrb. f. wiss. Bot. (Pringsheim), xxv. (1893) pp. 370-9.

† Malpighia, vii. (1893) pp. 393-6.

‡ Flora, lxxvii. (1893) pp. 419-22.

§ Ann. Sci. Nat. (Bot.), xviii. (1893) pp. 1-35 (2 pls.).

during the early period of the germination of the seed, and immediately after the opening of the flower.

**Radiation and Absorption of Heat by Leaves.\***—Herr A. G. Mayer states that, with one exception (*Arctium Lappa*), in all the plants examined by him the dark heat-rays are radiated with equal intensity from the two sides of the leaf. In *Arctium Lappa* the radiation from the under side was only 81 per cent. of that from the upper side. A slight deposit of dew reduced the radiation to 78 per cent., a heavy deposit to 66 per cent. of the normal intensity. The absorption of heat by leaves varied between 67 and 86 per cent., according to the species.

**Presence of Mannite in Wine (Mannitic Ferment).†**—The presence of mannite in wine, especially the red wines of Algeria, Spain, and Italy, has only excited the attention of chemists during the past few years. MM. U. Gayon and E. Dubourg have isolated and cultivated on various natural and artificial media the mannitic ferment which was obtained in the first place from a white Algerian wine. The organism is a very small motionless rodlet, which collects in little heaps. In grape must or sweet wine it grows well, but still better in solutions of invert sugar to which 20–30 grm. of Liebig's extract per litre have been added. Whatever the medium there is no cloudiness, no gas formation, and the ferment sinks to the bottom, where it forms a thin whitish deposit. It lives in the presence or absence of air equally well. The mere presence of mannite in any wine is easily detected by slowly evaporating without heat 2 or 3 ccm. of wine in a watch-glass; if any mannite be present, there will be found after the lapse of 24 hours delicate acicular crystals which have a silky look and a radiating arrangement. The mannitic fermentation is favoured by the elevated temperature, and thus an indication for its prevention is afforded. By keeping the temperature of the fermentation vats below 30°, the production of mannite is quite prevented, and the alcoholic fermentation not interfered with.

The authors further show that the mannite disease of wine is not the same as that when wine becomes tart or sour; for the former does not develop in wines that are devoid of sugar, while the souring ferment is easily cultivated in such fluids. The volatile acid product of the mannitic fermentation is exclusively acetic acid, while in soured wine it is a mixture of propionic and acetic acids. From sour wine the cream of tartar disappears, but it is not decomposed by the mannitic ferment. The mannitic ferment differs in shape, size, and general arrangement from the ferment of sour wine.

## B. CRYPTOGRAMIA.

### Cryptogamia Vascularia.

**Embryo of Ferns.‡**—Prof. G. F. Atkinson has observed that in *Pteris serrulata* and *Adiantum cuneatum* the two cells which result from the primary division of the oosphere are of unequal size (corresponding also to Goebel's figure of the process in *Adiantum capillus Veneris*). The

\* Amer. Journ. of Sci., xlv. (1893) pp. 340–6. See Bot. Centralbl., lvi. (1893) p. 36.

† Ann. Inst. Pasteur, viii. (1894) pp. 108–16 (1 fig.).

‡ Bull. Torrey Bot. Club, xx. (1893) pp. 405–8.

anterior segment, from which the stem is developed, is smaller, and has a smaller nucleus, than the posterior segment from which the root is developed. This is probably dependent on the larger requirements for nutrition of the latter than of the former segment.

The same author also records the occurrence of two fully developed embryos on a prothallium of *Adiantum cuneatum*.

**Annulus of the Sporangium of Ferns.\***—Prof. G. F. Atkinson describes in detail the structure of the annulus of the sporangium—both the incomplete annulus of the Polypodiaceæ and the so-called “complete” annulus of the other orders. In no cases is it truly complete. In the Cyatheaceæ, Gleicheniaceæ, Hymenophyllaceæ, Schizæaceæ, and Osmundaceæ, as well as in the Polypodiaceæ, the true cells of the annulus are always interrupted by “connective” cells which connect the lip-cells and the anterior end of the annulus on the one hand with the pedicel on the other. They take no part in the dehiscence of the sporangium, but remain passive, and thus prevent the rupture of the membrane of the sporangium, retaining the spores in their place until they are violently scattered by the rupture of the annulus.

**Classification of Sigillariæ.†**—Herr H. Potonié points out that the five groups of Sigillariæ proposed by Weiss, and founded on the sculpturing of the surface of the stem, cannot be retained, since sculpturing characteristic of two different groups may be found in the same species, and even on different parts of the same specimen. The growth of the Sigillariæ, like that of the Cycadeæ, appears to have been characterized by an alternation of zones of growth.

**Sphenophyllum.‡**—Fresh observations by M. R. Zeiller confirm his view that *Sphenophyllum* should be constituted into a distinct class of Vascular Cryptogams, most nearly allied to the Filicineæ, but having analogies also with the Marsileaceæ and Ophioglossaceæ. The species appear to have only one kind of sporangium; the sporocarp is a lobe of a leaf corresponding to the spike of *Ophioglossum* or *Botrychium*.

#### Muscineæ.

**Braithwaite's British Moss-Flora.**—Part xv. of this beautiful work includes a description of the remainder of the Bryaceæ, and of the whole of the Bartramiaceæ of the British flora. 38 species of *Bryum* are enumerated. The British representatives of the Bartramiaceæ include 1 species of *Conostomum*, 5 of *Bartramia*, 7 of *Philonotis*, 1 of *Breutelia*, and 1 of *Catoscopium*.

**Vegetative Structure of Hepaticæ.§**—Prof. K. Goebel describes the structure of the auricles and other structures for the collection of water in a number of Hepaticæ. This purpose is in many cases served by the occurrence of lamellæ on the leaf, or by its being cut up into linear

\* Bull. Torrey Bot. Club, xx. (1893) pp. 435-7.

† Gesell. Naturf. Freunde Berlin, Oct. 17, 1893. See Bot. Centralbl., lvii. (1894) p. 65.

‡ Mém. Soc. Géol. de France, iv. (1893) 39 pp. and 3 pls. See Morot's Journ. de Bot., viii. (1894) Bull. Bibl., p. 111. Cf. this Journal, 1892, p. 827.

§ Flora, lxxvii. (1893) pp. 423-59 (2 pls. and 18 figs.).



segments. Good instances of the latter are afforded by *Trichocolea tomentosa* and *Lophocolea muricata*; and of lamellæ on the leaf by *Gottschea sciurea*. Water-sacs occur even in a thallose species, *Metzgeria saccata*. In no case do these receptacles appear to be intended for the capture of insects; their object is simply to render it possible for the surface of the plant to be kept constantly moist, without which the majority of the epiphytic species could not exist. The water-sacs are especially well developed in the genera *Lejeunia*, *Colura*, *Frullania*, and *Physotium*; in *Colura* and *Physotium* they are furnished with a movable lid. That assimilation takes place in the water-sacs is shown by the fact that the air-bubbles which they usually contain increase considerably in size under strong illumination.

**Vegetative Organs of Hepaticæ.\***—Herr G. Ruge has studied the structure of the vegetative organs in a large number of Hepaticæ. The following are the more important results:—

*Cyathodium* (Marchantiaceæ) presents the simplest case of a sharp differentiation between the assimilating and the storing tissue; the cells of the dorsal side contain chlorophyll, those of the ventral side starch. In *Monoclea Forsteri* minute crystals of calcium oxalate were detected, the first time this substance has been observed in any of the Muscineæ. The development of the male and female organs in this species is described in detail, the former being now observed for the first time.

In addition to its occurrence in the frondose Jungermanniæ, a distinct mid-rib exists also in *Dendroceros* among the Anthocerotæ. The highest development of assimilating tissue occurs in the Ricciaceæ and Marchantiaceæ. In many Hepaticæ there is found also a specially differentiated mucilage-tissue; an excretion of mucilage in some form is characteristic of all Hepaticæ; the special mucilage-tissue in the thallus occurs only in the Anthocerotæ and Marchantiaceæ.† That of the Anthocerotæ is now described for the first time. *Nostoc* is very commonly found in the mucilage-cavities, and its parasitism greatly modifies their structure. At the base of the female fructification of *Monoclea Forsteri* is a dense tuft of mucilage-hairs.

The vegetative multiplication of the Hepaticæ takes place in a great variety of ways. It is effected either by the regeneration of the thallus or by means of special organs. Adventitious shoots occur in the Jungermanniaceæ, in *Cyathodium*, and in *Metzgeria*. In some tropical species tubercles are formed which have not hitherto been described; they appear to be a protection against periodic desiccation. Gemmæ (*Brutknospen*) are not uncommon in the Anthocerotæ.

**Stem and Leaves of Physotium.‡**—Mr. J. Reeves describes the development and structure of the auricles or water-sacs in *Physotium giganteum*, and the provision for the conduction of water into their cavity. The stem of this species presents the remarkable peculiarity that it grows by a two-sided apical cell, instead of the three-sided cell hitherto supposed to be universal in the acrogenous Jungermanniæ.

\* Flora, lxxvii. (1893) pp. 279-312 (1 pl. and 15 figs.).

† Cf. this Journal, 1884, p. 262. ‡ Journ. of Bot., xxxii. (1894) pp. 33-5 (1 pl.).

## Algæ.

Stichids and Tetrasporanges of *Dasya*.\*—Mr. B. W. Barton describes the development and structure of these organs in *Dasya elegans*. The stichids are scattered along the axis without any apparent order, and spring from ordinary vegetative cells. The tetrasporanges are produced in them in acropetal succession, and their cells are connected with one another by protoplasmic threads.

*Actinococcus*.†—Prof. F. Schmitz adduces additional arguments in favour of his view that the so-called "nematheces" on the frond of species of *Phyllophora* are in reality the sporangial fructification of an epiphytic alga of doubtful position among the Phæosporeæ, since the sexual organs are unknown. The typical species of this epiphytic genus, *Actinococcus roseus*, constitutes the so-called cystocarps of *P. Brodiaei* and of *P. interrupta*. Other species occur as epiphytes on different species of the genus *Gymnogongrus*. On three other species of *Phyllophora*, *P. Heredia*, *nervosa*, and *rubens*, nematheces have also been described; and these prove also to be the tetrasporanges of an epiphytic alga resembling *Actinococcus*, which, however, the author separates as a distinct genus under the name *Colacolepis*. The diagnoses of these two genera are given in detail. The filaments of the epiphyte penetrate into the tissue of the host, and the cells of the two become closely united with one another. The epiphyte develops as an incrustation on the outer surface of the stalk-like basal portion of proliferous lateral shoots of the host-plant, the appearance of which they sometimes altogether change.

M. M. Gomont ‡ confirms, in a general manner, the observations of Schmitz. The parasitic alga is composed of two parts, an epiphytic and an endophytic. Two kinds of tubercular protuberances are found on *Ahnfeltia plicata*, one due to the attacks of animals or bacteria, and of the nature of a gall; the other the fructification of a parasitic alga allied to *Actinococcus*.

Structure of *Caulerpa*.§—Herr P. Klemm objects to the term "unicellular" as applied to *Caulerpa prolifera* and similar organisms. They should be regarded rather as "symplasts," composed of a number of energids in Sachs's use of the term. The plasmode contained in the symplast is capable of independent nourishment, through its chlorophyll. He considers also the ordinary view of the purpose of the cellulose beams—viz. that they serve to give solidity to the plant—to be the correct one, rather than Noll's,|| that their main purpose is the conveyance of nutritive substances. By growing specimens in the dark, and on the klinostat, the author established the fact that the formation of the foliar proliferations is entirely dependent on light.

Low Forms of Algæ.¶—Herr R. H. Franzé gives details of the structure and life-history of the following freshwater Algæ (and Proto-

\* Studies Biol. Lab. Johns-Hopkins Univ., v. (1893) pp. 279-82 (6 figs.).

† Flora, lxxvii. (1893) pp. 367-418 (1 pl. and 8 figs.).

‡ Journ. Bot. (Morot), viii. (1894) pp. 129-35.

§ Flora, lxxvii. (1893) pp. 460-86 (5 figs.). || Cf. this Journal, 1889, p. 558.

¶ Oesterr. Bot. Zeitschr., xliiii. (1893) pp. 202-5, 247-52, 282-6, 346-50, 381-6 (1 pl. and 2 figs.).

phyta): — *Eudorina elegans*, *Phacotus lenticularis*, *Euglena sanguinea*, *Phacus longicaudus*, *Dictyosphaerium Ehrenbergianum*, *Raphidium polymorphum*, *Scenedesmus dimorphus*, *Sciadium Arbuscula*, *Celastrum microporum*, *Sorastrum echinatum*, *Pleurotænium Trabecula*, *Arthrodesmus convergens*. Wolle's *Eudorina stagnalis* he states to be indistinguishable from *E. elegans*. Of *Phacotus lenticularis* he describes two new varieties, *P. globulosus* and *spinifer*. Of *Dictyosphaerium* there are three distinct species, *D. Ehrenbergianum*, *reniforme*, and *Hitchcockii*; *D. pulchellum* and *globosum* are forms of the first, *Dimorphococcus cordatus* of the second of these. *Raphidium falcula* and *convolutum* must be united with *R. polymorphum*. The cells of *Sciadium Arbuscula* contain a true chlorophore, having the form of about five discs running obliquely across the cell, corresponding to the six swarm-spores which are produced in each cell. The genus appears to be nearly related to *Ophiocytium* and *Actidesmium*. The propagation of *Celastrum microporum* was followed in its various stages. In *Pleurotænium Trabecula* the author states that there are always as many as ten, and usually twelve longitudinal bands of chlorophyll. In *Arthrodesmus* the spines are simply prolongations of the cell-membrane.

#### Fungi.

**Ferment in Fungi.\***—M. E. Bourquelot finds, in 23 species of fungi parasitic on living trees or growing on dead wood, a soluble ferment, which has the power of decomposing glucosides such as amygdalin, salicin, and coniferin. It appears probable that, by the aid of this ferment, the fungi are able to utilize as food the various glucosides present in the bark, cambium, and woody tissues of the tree. No similar ferment was obtained from nine species of fungi growing on the soil.

The same author has further investigated † the inverting power of *Aspergillus niger* on a nutrient solution containing sugar, and finds that the following ferments have been produced:— (1) invertin, (2) maltase, (transforming maltose into glucose), (3) trehalase (changing trehalose into glucose), (4) emulsin, (5) inulase (transforming inulin into levulose), (6) diastase, (7) albumen-ferments, e. g. trypsin and pepsin.

**Fungi which Feed on Arsenic.‡**—Herr S. Csapodi records the remarkable fact that several mould-fungi, especially *Mucor Mucedo*, will grow on solid compounds of arsenic, dissolving them, and giving off arsenical vapours.

**Lagenidium and Chytridiaceæ.§**—M. E. de Wildeman gives a revised monograph of the species of *Lagenidium*, from characters derived in great part from the oosperm. A new species is described, *L. Closterii*, parasitic on *Closterium striolatum*. Two new species of Chytridiaceæ are described:— *Cladochytrium Hippuridis* on *Hippuris vulgaris*, and *Myzocytium megastomum* on various desmids.

\* Comptes Rendus, cxvii. (1893) pp. 383-6.

† Bull. Soc. Mycol. France, 1893, p. 230. See Bot. Centralbl., lvi. (1894) p. 200.

‡ SB. K. Ungar. naturw. Gesell. Budapest, Oct. 11, 1893. See Bot. Centralbl., lvii. (1894) p. 101.

§ Ann. Soc. Belge Microscopie, xvii. (1893) pp. 42-63 (2 pls.). Cf. this Journal, 1893, p. 765.



**New Genera of Fungi.**—Under the name *Matruchotia varians*, M. E. Boulanger \* describes a fungus found on the bark of a South American root, which he makes the type of a new genus belonging to the Basidiomycetes, but which, cultivated under certain conditions, may assume all the characters of the Mucedineæ. The genus is thus defined:—Thallus filamentous, aggregated, with an erect branched sporiferous apparatus; hymene wanting; fertile hyphæ bearing numerous lateral and a single terminal basid, each basid producing two smooth ovoid colourless spores, 6 by 4 to 4.5  $\mu$ .

M. E. de Wildeman † finds among freshwater algæ a lowly-organized fungus allied to *Titea*, which he describes as *Tetracladium Marchalianum* g. et sp. n. The following is the diagnosis of the genus:—Pluricellular, composed of four diverging branches springing from the same point; branches more or less acute; protoplasm colourless, destitute of a chromatophore; gemmæ are produced in the axils of the three upper branches and at the base.

M. J. Costantin ‡ has found on starch an Ascomycetous fungus forming the type of a new genus which he names *Eurotiopsis*. It is allied to *Eurotium*, but differs in the nature of its peritheces, and in the structure of its conidial apparatus.

**Parasitic Fungi.**§—Herr N. Lapine finds that in many cases cancer of the apple-tree is produced directly by the attacks of *Nectria ditissima*.

Dr. C. v. Tubeuf || describes the effects of the following parasitic fungi:—*Valsa oxystoma* and *Polyporus ignarius* on *Alnus incana*; *Gibbera Vaccinii* on *Vaccinium Myrtillus*; *Exobasidium Rhododendri*, *Cenangella Rhododendri*, *Sclerotinia Rhododendri*, and *Chrysomyxa Rhododendri*, on the alpine species of *Rhododendron*; *Gymnosporangium juniperinum* and *clavariæforme* on *Juniperus communis*; *Herpotrichia nigra* sp. n. on various conifers; *Exobasidium Vaccinii* on *Vaccinium Vitis Idæa*, *uliginosum*, and *Myrtillus*; *Uromyces Primulæ* on *Primula villosa*; *Rhytisma salicinum* on *Salix reticulata* at the highest altitudes; *Cronartium asclepiadeum* on *Cynanchum Vincetoxicum*; *Ustilago Jensenii* on barley; *U. Maidis* on maize; *Rhytisma acerinum* and *punctatum* on the sycamore.

Herr B. Frank ¶ describes the injuries inflicted on cucumbers by the attacks of *Cladosporium Cucumeris*, which may possibly be identical with the *Sporidesmium* found on the fruit.

M. G. Delacroix \*\* records the parasitism of *Isaria dubia* sp. n. on insects; of *Phyllosticta Cyclaminis* on *Cyclamen persicum*; of *P. glaucispora* on *Nerium Oleander*; and the growth of *Frachizæa rostrata* on dead roots of the vine, from the pycnids of which fungus springs a luxuriant growth of *Fusarium Muntzii*.

\* Rev. Gén. de Bot. (Bonnier), v. (1893) pp. 401-6 (3 pls.).

† Anu. Soc. Belge Microscopie, xvii. (1893) pp. 35-40 (1 pl.).

‡ Bull. Soc. Bot. France, xl. (1894) pp. 236-8.

§ Landwirthsch. Jahrb., xxi. (1892) p. 937. See Bot. Centralbl., lvii. (1894) p. 23.

|| Zeitschr. f. Pflanzenkrankheiten, iii. (1893) pp. 140-3, 201-5. See Bot. Centralbl., lvii. (1894) p. 86.

¶ Zeitschr. f. Pflanzenkrankheiten, iii. (1893) pp. 30-1. See Bot. Centralbl., lvii. (1894) p. 121.

\*\* Bull. Soc. Mycol. France, 1893, p. 264 (1 pl.). See Bot. Centralbl., lvii. (1893) p. 133.



Herr C. Raunkjær\* describes two new parasitic fungi, *Peronospora stigmaticola* on the stigmas of *Mentha aquatica*, and *Entomophthora Nebriæ* on a coleopter *Nebria brevicollis*.

M. E. Prillieux† states that *Polyporus hispidus* is exceedingly destructive to pears, mulberries, and other fruit-trees. The hyphæ excrete a ferment which destroys the starch in the parenchymatous tissue, and reduces the cellulose to a brown gummy mass.

A similar disease is, according to Prof. R. Hartig,‡ produced in the trunk of oak-trees by *Aglaospora taleola*.

Herr E. Rostrup § describes the injuries inflicted on a large number of forest trees in Denmark by parasitic fungi, viz.:—*Agaricus melleus* and *Trametes radiciperda* on many conifers; and the latter also on the root of the ash; *Polyporus fomentarius* on the elm; *P. radiatus* on the alder, birch, and beech; *P. vegetus* on the beech, elder, and other trees; *Melampsora pinitorqua* on *Pinus montana*, especially in the neighbourhood of *Populus tremula*; *Taphrina cerulescens* on the leaves of the oak; *Lophodermium Pinastris* and *Hypoderma sulcigenum* on conifers; *Nectria ditissima* on the oak, *Populus alba*, and *Salix alba*; *Myxosporium devastans* sp. n. on the birch; *M. carneum* on the beech; *M. lanceola* on the oak.

The same author || enumerates the species of Entomophthoraceæ, Hypocreaceæ, and Hyphomycetes parasitic on Arthropoda in Denmark. Three new species are described:—*Isaria aspergilliformis* sp. n., parasitic on small spiders, *Verticillium Aphidis* on aphides; *Botrytis Muscæ*, sp. n., probably, like the last, the conidial form of a *Cordyceps*.

Herr C. v. Tubenff ¶ describes the structure and life-history of *Empusa Aulicæ*, and the injuries inflicted by it on a Noctuid larva.

MM. E. Prillieux and G. Delacroix \*\* find *Cercospora Odontoglossi* parasitic on *Odontoglossum crispum*, *Macrophora suberis* on *Quercus suber*, *Ramularia Onobrychidis* on *Onobrychis sativa*, *Phyllosticta cicerina* on *Cicer arietinum*, *Vermicularia conidifera* on *Dracæna*, *Cytispora Pandani* on *Pandanus utilis*, *Septoria Carrubi* on *Ceratonia siliqua*, *Cladosporium herbarum* on *Cycas*. They also describe the spermogones of *Fusicladium pirinum*, parasitic on the pear.

According to the same authors †† a cancer-like disease is produced on the trunk of *Castanea vulgaris* by the attacks of *Diplodia Castanææ* sp. n.

**Development of *Penicillium luteum*. ††**—Herr C. Wehner describes in detail the structure and development of this very common green mould on fruits, and the characters by which it is distinguished from *P. glaucum*. The ascus-fructification is formed abundantly in this species.

\* Bot. Tidskr., xviii. (1893) pp. 108–111. See Bot. Centralbl., lvii. (1894) p. 134.

† Bull. Soc. Mycol. France (1893) p. 255. See Bot. Centralbl., lvii. (1894) p. 175.

‡ Forstl.-naturw. Zeitschr., 1893, pp. 1–6 (4 figs.). See Bot. Centralbl., lvii. (1894) p. 180.

§ Tidskr. f. Skovvæsen, 1893, pp. 97–117. See Bot. Centralbl., lvii. (1894) p. 182.

|| Vidensk. Meddel. naturh. Foren. Kjöbenhavn, 1893, pp. 78–95. See Bot. Centralbl., lvii. (1894) p. 184.

¶ Forstl.-naturw. Zeitschr., 1893, pp. 31–47 (7 figs.). See Bot. Centralbl., lvii. (1894) p. 185.

\*\* Bull. Soc. Mycol. France (1893) p. 230. See Bot. Centralbl., lvii. (1894) p. 200.

†† Bull. Soc. Mycol. France (1893) p. 257 (1 fig.). See Bot. Centralbl., lvii. (1894) p. 180.

‡‡ Ber. Deutsch. Bot. Gesell., xi. (1893) pp. 499–516 (1 pl.).

The mode of germination, both of the conids and of the ascospores, is also described.

*Aspergillus* developing in Sulphate of Quinine.\*—M. F. Heim has found in solutions of sulphate of quinine an abundant fungus-mycete producing fructifications which show it to belong to the genus *Aspergillus*. He proposes for it the name *Aspergillus quininae* sp. n. (?)

*Trichosphæria Sacchari*.†—Mr. G. Massee describes the life-history of this ascomycetous fungus, which is very destructive to the sugar-cane in the West Indies. Its life-cycle consists of three stages, the *Melanconium*, the megaconidial, and the ascigerous stage. The hyphæ developed from *Melanconium*-conids eventually give rise to stout lateral branches, which in turn bear apical chains of megaconids (macroconidia). Both forms of conid are produced in chains; in the chains of megaconids the apical one is very large and spherical, while the rest are smaller and elliptical; their mode of formation somewhat resembles that of the hormogones of the lower Algæ. Although a true parasite in its later stages, *Trichosphæria* almost invariably commences its existence as a saprophyte.

Wrinkle-scurf.‡—Dr. J. Müller has studied the fungi which cause the diseases known as "wrinkle-scurf" (*Runzelschorf*), a term hitherto confined to those produced by species of *Rhytisma*, belonging to the Discomycetes. Of this genus he describes a new species, *R. symmetricum*, on leaves of *Salix purpurea*. *R. acerinum*, on species of *Acer*, and *R. salicinum*, on species of *Salix*, are also described in detail. Besides these the author establishes two new genera, *Discomycopsis*, for *D. rhytismoides* g. et sp. n., on the maple; and *Diachora*, for *D. Onobrychidis* g. et sp. n., on *Onobrychis sativa* and *Lathyrus tuberosus*.

Germination of the Uredineæ.§—Mr. C. A. Carleton describes a series of experiments on the germination of these fungi, especially on the effect of different chemicals, and on the vitality and vigour of the summer spores. He also records the occurrence of a new form of sporid, catenulate instead of pedicellate, in three species, *Puccinia Grindeliæ*, *P. variolans*, and *P. Sporoboli*.

Nuclear Division in the Hymenomycetes.||—Mr. H. Wager has studied the phenomena connected with the division of the nucleus in the cells of the Hymenomycetes, especially in the basids, where they are unusually large. The species examined were *Agaricus stercorearius* and *A. muscarius*.

The young basids contain a single nucleus formed by the fusion of two or more pre-existing nuclei. The structure of the nucleus is similar to that in the higher plants; it possesses a nuclear membrane, nucleole, and granular network. On staining with carmine and nigrosin the network becomes blue, the nucleole a deep reddish purple. The mode of division of the nucleus is karyokinetic, resembling generally that which takes place in the higher plants, but with slight differences of

\* Bull. Soc. Mycol. France, 1893, p. 239. See Bot. Centralbl., lvii. (1894) p. 239.

† Ann. Bot., vii. (1893) pp. 513-52 (1 pl.).

‡ Jahrb. f. wiss. Bot. (Pringsheim), xxv. (1893) pp. 607-27 (3 pls.).

§ Bot. Gazette, xviii. (1893) pp. 447-57 (2 pls.).

|| Ann. Bot., vii. (1893) pp. 489-514 (3 pls.). Cf. this Journal, 1892, p. 654.

detail. The daughter-nuclei divide in the same manner as the parent-nucleus. The four nuclei thus produced pass at once to the base of the basid and present the appearance of fusing together. After a time they separate again, pass to the apex of the basid, and place themselves immediately at the base of the sterigmata. Previous to their entry into the spores the nuclei decrease in size, their outline and network become indistinct, and they are hardly distinguishable from the surrounding protoplasm.

The observations on the staining reactions of the nuclei in the various stages of division seem to point to the conclusion that a portion of the dissolved nucleolar substance is taken up into the chromatic elements as fast as the nucleole becomes dissolved.

Phalloideæ.\* — Pursuing his investigations on the structure and life-history of this group of Fungi, Dr. E. Fischer calls special attention to the following points of structure. In *Lysurus* the glebe lies outside the receptacle; but the first differentiation of the fructification agrees with that of *Clathrus*, and the genus belongs to the Clathreæ. In *Ithyphallus impudicus* the pileus is derived only from a single zone of tissue, the rudiment of the indusium remaining in the condition of a loose web. In *I. Ravenelii* the pileus has a chambered structure, and there is no indusium.

In the Clathreæ we find a transitional series of forms from the clathrate, like *Clathrus*, to the stalked, with free arms, like *Aseroe* and *Calathiscus*. In this series the glebe becomes more and more localized, between the condition in *Clathrus*, where it occupies the whole of the space enclosed by the receptacle, and that in *Calathiscus*, where it surrounds only the border of the mouth of the stipe. The transitional forms occur especially in Australia.

The affinity of the Clathreæ on their lower side appears to be with the Hymenogastreæ through *Hysterangium*; there are no transitional forms between the Phalleæ and the Clathreæ. These two groups are distinct series springing respectively from *Hysterangium* and probably *Hymenogaster*, and reaching their highest development, the one in *Aseroe* and *Calathiscus*, the other in *Ithyphallus* and *Dictyophora*.

Position of *Pompholyx*.†—M. A. de Janczewski has examined the structure and development of *Pompholyx sapidum*, the white truffle of Bohemia, and considers it to belong to the Gasteromycetes, the genus being nearly allied to *Phlyctospora*, from which it differs in the absence of the hyaline cells surrounding the spores.

### Protophyta.

#### a. Schizophyceæ.

*Scenedesmus*.—As the result of culture experiments M. E. de Wildeman‡ reduces the known species of *Scenedesmus* to six well-marked (divided into two groups of Acuti and Obtusi) and four uncertain species. Many of the varieties and even of the species described by authors are

\* Denkschrift. Schweiz. Naturf. Gesell., xxxiii. (1893) 51 pp., 3 pls. and 5 figs. See Bot. Centralbl., lvii. (1894) p. 240. Cf this Journal, 1891, p. 78.

† Bull. Soc. Mycol. France, 1893, p. 169. See Bull. Soc. Bot. France, xl. (1893), Rev. Bibl., p. 151.

‡ La Notarisia, 1893, pp. 85-106 (1 pl.).



but stages of development of the same form. Neither the presence or absence, nor the arrangement, of the spines can be relied on as specific distinctions. On escaping from the mother-cell *Scenedesmus* consists of four daughter-cells arranged alternately at different levels, which are set at liberty by the irregular splitting of the membrane of the mother-cell. The nearest alliance of *Scenedesmus* appears to be with *Pediastrum*.

Prof. R. Chodat and Mme. O. Malinesco\* state that *Scenedesmus* is exceedingly polymorphic under cultivation. From a *Pleurococcus* form resembling *Glæocystis Naegeliana* they obtained, in distilled water, a form identical with *Raphidium minutum*. In an alkaline nutrient solution states were produced indistinguishable from *Dactylococcus infusionum* and *Scenedesmus acutus*. *Scenedesmus* has therefore a *Protococcus*, a *Raphidium*, and a *Dactylococcus* form.

**New Pleurococcus.**†—Under the name *Pleurococcus nimbatus* Herr E. de Wildeman describes a remarkable new species, in which the single cells or colonies of cells are surrounded by an aureole of a radial-fibrillar structure, invisible in water, but very visible in a solution of Indian ink.

**Intra-frustular Reproduction of Diatoms.**‡—Dr. G. B. de Toni confirms the observation of Castracane of the formation of new frustules within the old ones in the case of *Amphora ovalis*. The young frustules agree altogether with the description of the alleged species *A. minutissima*.

**Movements of Diatoms.**§—Herr O. Müller repeats his former explanation of the movements of diatoms as depending on forces connected with protoplasmic currents on the surface, and criticizes the conclusions which Bütschli has drawn from his own observations.¶ The threads which this authority describes as proceeding from the central node are, according to Müller, composed not of mucilage, but of protoplasm; they do not project through the mouth of the canal, but are entirely external. He asserts that there is no gelatinous envelope, as described by Bütschli and Lauterborn; that which has this appearance is the result of the treatment to which the diatoms have been subjected. A close examination of the phenomena negatives the hypothesis that the movement of the diatom is the result of the springing back of the thread; it is rather due to currents of cytoplasm passing in and out of the canal and along the surface.

**Relationship between the Morphology and Biology of Diatoms and their Classification.**¶—Herr F. Schütt reviews the various systems which have been proposed for the classification of diatoms. Those of Pfitzer and H. L. Smith are to a certain extent in harmony, the Placochromaticæ of the former corresponding in the main to the Raphideæ of the latter, the Coccochromaticæ to the Cryptoraphideæ (or Araphideæ). The author proposes to divide the Diatomaceæ into two primary divisions, the ground-forms or those attached to a substratum, and the plancton or floating forms; the latter are mostly Araphideæ, the former Raphideæ. Among the ground-forms two types

\* Bull. Herb. Boissier, i. (1893) pp. 184-90 (1 pl.). See Bot. Centralbl., lviii. (1894) p. 69. † Tom. cit., p. 337. See Bot. Centralbl., lvi. (1893) p. 78.

‡ Ber. Deutsch. Bot. Gesell., xi. (1893) Gen.-Versamml.-Heft, pp. 74-5.

§ Tom. cit., pp. 571-6 (1 fig.). Cf. this Journal, 1889, p. 793.

¶ Cf. this Journal, 1893, p. 769.

¶ Ber. Deutsch. Bot. Gesell., xi. (1893) pp. 563-71 (1 pl.).



may be distinguished from a biological point of view, the free and the stalked; the latter are chiefly Pseudoraphideæ, and form, both biologically and morphologically, a connecting link between the other two. The Raphideæ or Euraphideæ are the most highly developed type; the formation of auxospores is often preceded by the apparently sexual union of two cells; in the Araphideæ or plancton-forms, on the other hand, the auxospore is the product of a single mother-cell, as in *Chaetoceras* and *Rhizosolenia*. A similar process is now described for the first time in *Skeletonema costatum*. Although not without exception, the arrangement of the chromatophores is usually more or less uniform in the species of a genus, and even in nearly related genera.

**Protoplasts of the Cyanophyceæ.\***—Herr E. Palla has examined the structure of a number of species of Cyanophyceæ—*Glæotrichia Pisum*, *Tolypothrix lanata*, *Sphærozyga oscillarioides*, *Anabæna Azollæ*, *Nostoc humifusum*, *Oscillaria* sp., *Lyngbya papyrina*, *Chroococcus turgidus*, *Glæocapsa* sp., and the gonids of *Peltigera canina*—with the view of determining the nature of the central body. The protoplast contains uniformly a colourless and apparently homogeneous central portion, which divides by constriction and is stained by methyl-blue in the living state. The chromatophore has apparently a reticulate structure, and is separated from the central body by a colourless layer of protoplasm. The cells contain large vacuoles; and outside the central body are granular structures of two kinds—cyanophycin-granules and mucilage-globules. The cyanophycin-granules are apparently solid, and are usually found in the outermost portion of the chromatophore. The mucilage-globules are generally situated close to the central body; they are identical with the so-called nucleoles. When the spores of *Glæotrichia* germinate an oil makes its appearance in the cells.

The central body differs, according to Palla, in several important points from a true nucleus,—in the absence of a chromatin-framework and of nucleoles, and in its direct mode of division, which has nothing in common with the process of karyokinesis. If the central body is not a true nucleus, it follows that the Cyanophyceæ (and the Schizomycetes) are not a degraded type descended from higher organisms, but are an archaic type standing at the base of both the animal and the vegetable kingdoms.

Herr H. Zukal † believes one of the principal functions of the cyanophycin-granules to be the excretion of that substance. It is in these granules that cyanophycin, oil, and a red pigment are stored up. When the cyanophycin is expelled, it takes either a crystalline form or that of minute drops in the cytoplasm. These are frequently transformed into mucilage-globules, or into the “central mass” of authors, when they assume a great resemblance to a cell-nucleus.

### β. Schizomycetes.

**Action of Ozone on Micro-organisms.‡**—Sig. G. Tolomei states, from observations made chiefly on *Saccharomyces ellipsoideus* and *cerevisiæ* and

\* Jahrb. f. wiss. Bot. (Pringsheim), xxv. (1893) pp. 511-62 (2 pls.); and Ber. Deutsch. Bot. Gesell., xi. (1893) pp. 394-5. Cf. this Journal, 1892, p. 655.

† Ber. Deutsch. Bot. Gesell., xii. (1894) pp. 49-52.

‡ Atti R. Accad. Lincei, ii. (1893) pp. 354-61.

*Mycoderma aceti*, that, in very small quantities, so far from having a microbicidal influence, ozone favours the development of some organisms. A similar series of experiments is recommended on the pathogenic bacteria.

**Thermogenous Bacteria.\***—Experiments carried on by Prof. F. Cohn on the cause of the so-called “spontaneous combustion” of masses of cotton, grass, tobacco, &c., have led him to the conclusion that it is invariably due to a fermentation caused by thermogenous bacteria. No perceptible rise of temperature takes place in heaps of cotton, whether dry or moist, or even if saturated with oil, when the presence of bacteria is carefully excluded. The special micro-organism concerned in the combustion of cotton appears to be a *Micrococcus* which is present in great quantities in the soil of the cotton-plantations.

**Aceto-bacteria.†**—Herr E. C. Hansen gives further details respecting the life-history of the bacteria which produce acetic fermentation, viz. *Mycoderma aceti* and *M. Pasteurianum*, to which he now adds a third species, *M. Kützingianum*. All these species occur in three distinct forms,—as long filaments, as swollen bodies, and as chains; and the author has determined, by culture-experiments, that the second of these forms is an intermediate stage of development between the other two.

**Conversion of Starch into Sugar by *Bacillus anthracis*.‡**—M. Maumus states that when *Bacillus anthracis* is grown on potato, the starch contained in the substratum is gradually transformed into sugar, which subsequently disappears, being probably used up as nutriment by the microbe.

**Composite Cilia of *Bacillus*.§**—M. N. Sakharoff describes a microbe, *Bacillus asiaticus*, which was isolated from cholera stools. It is a mobile bacillus,  $4\ \mu$  at least long by  $1\ \mu$  broad, with rounded ends, and sometimes forms long threads and chains. It can be cultivated on the usual media, liquefies gelatin rapidly, is aerobic, and not pathogenic to guinea-pigs. The colonies on plates are circular or oval, and white or yellowish in colour. The chief interest of the organism is the presence of spiral cilia, easily observed without staining, and best from puncture gelatin cultivations at 24–36 hours after inoculation. They are motionless; the turns are quite regular, but the number of turns and the thickness of the cilia are variable. The author thinks that the spirals are the result of the union of the cilia of several bacilli. The Loeffler mordant was found to be inapplicable; but after weakening the action of the sulphate of iron by making the solution at the ordinary temperature satisfactory results were obtained. This modified solution was allowed to act for 5–10 minutes, and after staining with Ehrlich fuchsin the cilia were well seen.

**Gas and Acid Production by Bacteria.||**—Dr. Th. Smith finds, from experiments made with *Bacterium coli commune*, the hog-cholera group,

\* Ber. Deutsch. Bot. Gesell., xi. (1893) Gen.-Versamml.-Heft, pp. 66–9.

† Tom. cit., pp. 69–73.

‡ Compt. Rend. Soc. Biol., 1893, pp. 107–9. See Journ. Chem. Soc., 1894, Abstr., p. 62.

§ Ann. Inst. Pasteur, vii. (1893) pp. 550–3 (3 figs.).

|| Wilder Quarter-Century Book, 1893, pp. 187–232. See Centralbl. f. Bakteriologie u. Parasitenk., xiv. (1893) pp. 864–7.

*Bacterium lactis aerogenes*, *Bacillus œdematis maligni*, &c., relative to the production of gas in saccharose and lactose bouillon, that gas-production and acid-formation only take place in the presence of sugar or carbohydrates; fermentation phenomena are at once recognizable by the mere formation of acid, or by that of gas and acid; many bacteria form acid in the presence of sugar; gas and acid formation are valuable group-reactions. The quantity of gas and the formula  $\frac{H}{CO_2}$  are pretty constant for the same species of bacterium in fluids of the same composition; fermentation phenomena should be examined on different carbohydrates; when testing with saccharose and lactose the bouillon must be free from muscle sugar.

**Pathogenic Properties of Water Microbes.\***—Dr. Blachstein points out that the pathogenic properties of water are determined rather by the quality than the quantity of microbes it contains, and holds that if animals suffer from no ill effects after inoculation with cultivation from water, then the water thus tested may be considered hygienic and pure. By mixing 1 ccm. of the water to be examined with 10 ccm. bouillon, a mixture of different species of bacteria was obtained, and the effect of this tried on various animals. Most of the inoculations made with the Institute water had no harmful results, though 1 ccm. produced peritonitis, and a lesser quantity failed.

These results are held to show that the water supplied to the Institute Pasteur can be drunk without danger. The results of experiments made with Seine water taken from different places are mentioned to show the different effects produced on animals when injected with cultivations from different samples of water. The specimens taken from Point-du-jour were very fatal, those from St. Cloud inoffensive, and those from Billancourt, situate between the two former localities, less dangerous than those from Point-du-jour. The cultivations were found to contain coliform bacilli, *Proteus*, *Bacillus d'Hericourt*, and other liquefying bacteria. The more active mixtures were found to contain more coliform bacilli than the less active in which the liquefying forms predominated. The author isolated three species of vibrio having much resemblance to the *Vibrio cholerae asiaticæ*, though on the whole it had more likeness to the vibrio isolated by Netter.

**Nuclei of Anthrax Spores.†**—By a special method of staining, Herr W. Ilkewicz has been able to show that the protoplasm of *Bacillus anthracis* has a granular structure, and while it assumes a dark grey colour the spores either do not stain at all or are of a pale grey hue. The spores are described as being of three sizes, large, medium, and small. In the centre of the larger spores is located a black granule, and in very large ones there may be two such granules. The smallest spores are always devoid of the granules which the author considers to be the nuclei of the spores.

**Phagocytosis.‡**—In a reply to two attacks which have been made on the theory of Phagocytosis, M. E. Metschnikoff first criticizes the position

\* Ann. Inst. Pasteur, vii. (1893) pp. 689-92.

† Centralbl. f. Bakteriol. u. Parasitenk., xv. (1894) pp. 261-7 (1 fig.).

‡ Ann. Inst. Pasteur, viii. (1894) pp. 58-64. Cf. this Journal, 1893, p. 232.



of Kurt Müller,\* who, after experimenting on over 300 rats, the pedigree of which had been carefully ascertained, failed to discover that the resistance of rats to anthrax was in any way due to the action of phagocytes. The leucocytes, according to Müller, have no more to do with this resistance than many other elements of the tissues, and if they do, it is only as cells secreting bactericidal substances. This deduction was drawn from the observation that the degenerated bacteria were always found outside the cells and not within, though they may be seen in vacuoles of the hepatic tissue. M. Metschnikoff points out that as long ago as 1890 he demonstrated these vacuoles to be vacuoles in the macrophages, and a common phenomenon in the spleen and liver of rats dead of anthrax. Müller has overlooked the existence of the macrophage, and has made a phagocyte the equivalent of a leucocyte, and hence his position is untenable. The author then replies to Mr. E. H. Hankin who advocates the theory of alexocytes.† The alexocytes are the eosinophilous leucocytes, and the granules the source of the bactericidal property of the blood. Hankin has lately withdrawn (*vide ante*, p. 243) the word eosinophilous, substituting amphophilous for it. Of this alteration the author takes no notice, though he raises three principal objections to Mr. Hankin's scheme. The first is that the bactericidal property as observed in a medium devoid of eosinophilous granules is thoroughly maintained. The second is that bacteria are incorporated by living phagocytes and are not previously killed by the action of "alexines." The third is the fact that the phenomena of phagocytosis and of intracellular digestion can be observed in Invertebrata which do not possess eosinophilous granules. In addition to these objections the author points out that Mr. Hankin has not yet proved that the eosinophilous granules are secretion products, and expresses the opinion that these granules represent a nutritive deposit heaped up in the phagocytes, and are analogous to vitelline granules and aleurone grains, all three being coloured alike by eosin.

In conclusion, the author criticizes the statements of Messrs. Kantschack and Hardy, whose experiments on the frog with anthrax are put forward by Hankin in favour of his views. The deductions of those writers are dismissed by M. E. Metschnikoff on the ground that the observations are imperfect and the conclusions erroneous; they remarked that the eosinophilous cells approached the bacteria before the phagocytes proper did. The two kinds of cells afterwards fused into plasmodesms and then destroyed the bacteria previously rendered harmless by the granules.‡ The author has no hesitation about saying that the phenomena thus described have no foundation in fact, and therefore it is impossible for Hankin to support his theory of alexocytes from the observations recorded by Messrs. Kantschack and Hardy.

**New Bacterium of the Lymph.**§—Dr. H. J. Hamburger describes, under the name *Bacterium lymphagogen*, a new microbe whose presence quickens the lymph-stream, and produces, by altering the osmotic con-

\* Cf. *ante*, p. 246.

† Cf. this Journal, 1893, p. 515.

‡ Cf. this Journal, 1893, p. 158.

§ Verh. K. Akad. Wetenschap Amsterdam, iii. 5 (1893) 27 pp.



ditions, &c., a dropsical state. He gives an account of its occurrence in man, and of its influence when inoculated into the calf, and describes at length its morphological and biological characters.

**New Gas-forming Bacillus.\***—Dr. F. Gärtner describes a bacillus which was isolated from the guinea-pig. It is a short rodlet with rounded ends; its length is variable, being 4–12 times greater than the breadth, which is constant. It grows slowly on gelatin, and does not liquefy the medium. The growth on gelatin and agar is of a greyish-white colour, and on potato the growth varies with the temperature, the optimum being 24°, while that for agar is 37°. It is endowed with slight movement and possesses a single polar flagellum. The organism, which is a facultative aerobe, is best stained by Pfeiffer's method in Ziehl's fuchsin solution, and then decolorized with acetic-acid-alcohol, though cover-glass preparations are stainable by Gram's or Loeffler's methods. The most characteristic feature of the organism was the large amount of gas it gave off when cultivated in grape-sugar bouillon, 1½ and 3 per cent. The gases collected were carbonic acid and hydrogen. Pure cultivations were fatal to guinea-pigs and rabbits.

**Bactericidal Properties of Vasogen.†**—Dr. Max Dahmen records some experiments as to the bactericidal properties of vasogen. Vasogen is a vaselin impregnated with oxygen under a high pressure. This excess of oxygen imparts to the mixture the singular power of forming an emulsion with water, the product being named *Vaselinum oxygenatum vel Vasogen*. Many pharmacopœial substances are soluble in vasogen, e. g. iodoform, kreasot, ichthyol, menthol, pyoktanin, pyrogallol. It seemed useful therefore, to test the bactericidal property of the mixture. Experiments with *Vibrio cholerae asiaticæ* showed that vasogen itself had no influence, but, in conjunction with other substances having anti-septic properties, it forms a valuable adjunct.

**Influence of Physico-Chemical Agents on some Pathogenic Anaerobes of the Soil.‡**—The conclusions arrived at by Dr. F. Sanfelice as to the influence of physico-chemical agents on anaerobic pathogenic organisms found in the soil, such as those of malignant œdema, tetanus, symptomatic anthrax, are that the spores of pathogenic anaerobes are capable of resisting a high temperature for several hours; consequently they are not destroyed by heat in a short time, though they are killed in a comparatively short time by sunlight independent of heat. Spores of pathogenic anaerobes can remain alive for several days in water, whether this be fit for drinking, or contain putrefying animal or vegetable substances. These spores are very resistant to desiccation, to the action of gases constantly or occasionally present in the soil, and to chemical substances dissolved in the soil. The spores the most resistant to heat, sunlight, and chemical elements dissolved in the soil, are those of tetanus; those of the bacillus of malignant œdema are less so, and those of symptomatic anthrax the least.

\* Centralbl. f. Bakteriol. u. Parasitenk., xv. (1894) pp. 1–10.

† Op. cit., xiv. (1893) pp. 720–4.

‡ Ann. de Micrographie, v. (1893) pp. 409–36, 473–92.

Differences between *Bacillus typhosus* and "Typhoid" Bacilli.\*—Sigg. Germano and Maurea point out that terms like *Fæces-bacillus* (*Bac. neapolitanus*) and *Bacterium coli commune* are unsuitable, as they include a whole series of bacilli having different characters. From the same fæces or the same body quite a number of "typhoid" bacilli may be isolated. Though the morphological and biological characters of the typhoid-like bacteria are not absolutely constant, there are differences in their pathogenic properties, in their fermentation in milk and different sugars, their reducing power, and excretion of acid. Between these and the bacillus entericus or typhosus are numerous gradations, but the authors do not accept the view advocated by Rodet and Roux, who hold that there exists a definite transition between the "typhoid" like bacilli and *Bacillus typhosus*.

Of the numerous species three are frequent; one of these is a mobile bacillus, pathogenic to mice, which coagulates milk, gives the indol reaction, has great reducing power, decomposes, with development of gas, grape, milk, and cane sugars, and decolorizes jequirity solution.

Another typhoid bacillus differs from the foregoing in that it does not ferment cane sugar or decolorize jequirity solution. The third does not coagulate milk.

According to the authors there are no real differences between the typhus-bacilli of different origin, though some grow more strongly than others. From comparing 88 cultivations of typhoid bacilli, and 12 typhus cultures of different origins, the authors found that the occurrence or non-occurrence of gas development in puncture cultivations in agar with 2 per cent. grape sugar may be considered a certain diagnostic criterion, for the typhus bacillus does not excite gas formation, and this is all the more useful, as diagnosis may be made in 24 hours.

Other characteristics, such as absence of indol reaction, non-coagulation of milk, fermentation on sugar, pathogenic action, mobility, cilia, &c., have but a restricted value.

Value of Bacteriological Diagnosis of Asiatic Cholera.†—Prof. Sheridan Délépine comes to the conclusion that it is as yet impossible to speak dogmatically of the infallibility of the bacteriological diagnosis of cholera asiatica. As is well known, Cunningham and Klein have demonstrated the existence of a large number of varieties of spirilla in choleraic dejecta, and the observations of the former have not, perhaps, yet received the attention they deserve. The scepticism, therefore, of those who doubted whether some cases, which occurred in England last summer, were true cases of Asiatic cholera, seems to be justified.

Characteristic Mobility of the Typhoid Bacillus.‡—In experiments made for the purpose of determining the differential diagnosis of *Bacillus typhosus* and bacteria of a similar kind, Dr. C. Terni made some interesting observations on the mobility of this organism. The medium on

\* Ziegler's Beiträge, xii. p. 494. See Centralbl. f. Bakteriol. u. Parasitenk., xv. (1894) p. 60.

† Brit. Med. Journ., 1894, No. 1725, pp. 120-2.

‡ Ann. Ist. d'Igiene Speriment. d. R. Univ. d. Roma, iii. N.S. fasc. 3. See Centralbl. f. Bakteriol. u. Parasitenk., xv. (1894) pp. 249-50.

which the mobility is best exhibited was a pepton-free bouillon, with three per cent. glycerin, and having an acidity equivalent to 0.01 HCl. In this *Bacillus typhosus* retained its mobility for eight days and longer. In 1 per cent. pepton-bouillon it ceased to move after 72 hours, though during that time it was extremely lively when the medium was neutral or slightly acid. As the microbes move they pass in long strings parallel to the side of the drop. During observation the temperature should not sink below 12°. The mobility is diminished or destroyed by many conditions affecting the chemical and physical composition of the medium, such as too prolonged boiling, excess or defect of alkalinity and acidity, the presence of certain salts or substances, and so on. In clean spring, river, or sea water the typhoid bacillus is motionless, but it becomes mobile in the presence of a small quantity of organic matter. If it should lose its mobility it may regain it when the conditions are favourable. *Bacterium coli* and other typhoid-like organisms examined by the author are motionless in acid media, and their mode of progression is quite different from that of the typhoid bacillus, which has a characteristic motion of its own.

**Red Cocco-bacillus of the Sardine.\***—Dr. Du Bois Saint-Sévrin describes a chromogenic micro-organism which had contaminated the fish at a sardine factory. The contamination was the more interesting as seven out of the ten solderers were affected with whitlow. At the factory itself there was a strong odour of trimethylamin. Pus was taken from a suppurating whitlow and inoculated on gelatin and in bouillon; from the former subcultures were made on potato and on sterilized sardines in oil.

After an incubation of some hours at 37° there appeared an abundant bright red growth, exhaling the odour of trimethylamin. On microscopical examination there was found a very small cocco-bacillus, indeed the same organism which had been detected in the infected sardine boxes.

The cocco-bacilli are very mobile; they occur in pairs, are scarcely longer than broad, measuring 0.5–0.6  $\mu$ . They are easily stained, and as easily part with anilin colours. Liquefaction of the medium and the rose or ruby colour are prominent culture characters. Besides the bacilli, hanging drop cultivations show round red bodies, which may attain a diameter of 4–5  $\mu$ ; these disappear when treated with nitric acid, and hence are probably a mixture of colouring matter and crystals. The colouring matter is soluble in alcohol and water. The alcoholic solution is heightened by addition of acid, and turned yellow by alkalis.

Inoculation experiments on animals showed that the red microbe was devoid of pathogenic properties. The author, however, had also isolated an anaerobic micro-organism. This was a thin bacillus of variable length which did not liquefy gelatin but produced gas and exhaled a fetid odour. When inoculated on a rabbit, this organism also failed to produce any morbid action by itself, but a mixture of the two microbes caused an abscess, in the pus of which both were found. From this it is supposed that the whitlows were the result of a mixed infection.

\* Ann. Inst. Pasteur, viii. (1894) pp. 152–60 (2 figs.).



**Laser's Bacillus of Mouse-disease.\***—Dr. H. Laser makes a communication relative to the pathogenic action of the bacillus of mouse-disease on wether sheep. The experiments on geese, swine, and cows were negative, while the two sheep died. In both were found a short plump bacillus, not resembling at all in appearance the bacillus of mouse-disease, but which, like the latter, was fatal to mice. The bacillus of mouse-disease was not detected in either case. These results of course raised the question whether it would or not be dangerous to use the mouse-disease bacillus for killing off mice. The author thinks that the danger to sheep is one that may be neglected, as cultivations made from pieces of bread which had been soaked in bouillon cultures and placed on the ground were found to have become inert on the fourth day. Two extensive experiments were carried on, one in East, the other in West Prussia, and the results in both cases were satisfactory, and no ill-effects on other animals ensued. The author concludes by asserting that the employment of his mouse bacillus is practicable, and only requires that the pieces of bread should be put right down into the holes to ensure a successful result.

**Parasite of the Madura Foot.†**—M. H. Vincent describes a case of madura foot, a disease almost entirely confined to India, which occurred in a patient in Algeria. Many of the phenomena observed had some resemblance to those occurring in actinomycosis. From the foot, which had for years been getting larger from the presence of slow-growing tumours, exuded yellowish pus in which numerous "grains" about the size of a large pin's head were constantly present. Microscopical examination of these grains, which are insoluble in potash or acetic acid, showed, when stained with some anilin dye (methylene-blue, fuchsin) that they are composed of a dense and intricate network formed of a fine mycele. The filaments present a true branching, and hence the parasite belongs to the genus *Streptothrix*, and the author calls it *S. maduræ*. The filaments are from 1 to 1.5  $\mu$  thick, and, though they are arranged somewhat after the manner of *Actinomyces*, present no club-shaped appearances. Successful cultivations were made in vegetable infusions, the optimum temperature being 37°, though even in ordinary gelatin *S. maduræ* forms along the needle track as a white deposit. The following medium was found to answer best:—Infusion of hay or potato, 100 ccm.; gelatin, 9 grm.; glycerin, 4 grm.; glucose, 4 grm. On some cultivations on potato there formed rose or red colonies after incubation at 37° for four to five weeks. The microbe is aerobic, does not liquefy gelatin, does not coagulate milk, but peptonizes it slowly.

*Streptothrix maduræ* forms spores; these are larger than the mycele elements, being about 1.5  $\mu$  broad and 2  $\mu$  long; these were found to develop at points in contact with the air, and best in hay infusion.

Inoculation experiments on animals failed.

There is in some respects a striking resemblance between actinomycosis and madura foot, but there are also marked differences. Thus treatment with potassium iodide is of great service in actinomycosis; it is of no avail in madura foot. *Actinomyces* liquefies gelatin, *S. maduræ*

\* Centralbl. f. Bakteriöl. u. Parasitenk., xv. (1894) pp. 33-6.

† Ann. Inst. Pasteur, viii. (1894) pp. 129-51 (1 pl.).



does not. Cultivations of *Actinomyces* on potato are yellow, those of *S. maduræ* red. The former is a facultative anaerobe, the latter is essentially aerobic. *Actinomyces* has been successfully inoculated on the rabbit, guinea-pig, and calf.

- BECK, S.—Bakteriologische Untersuchungen des Wassers. (Bacteriological Examination of Water.) *Orvosi hetilap.*, 1894, No. 8 [Hungarian].
- CAPITAN, L.—Le rôle des microbes dans la société. (The part played by Microbes in Society.) *Rev. Scientif.*, 1894, pp. 289-94.
- D'ARSONVAL & CHARRIN—Influence de l'électricité sur la cellule microbienne. (Influence of Electricity on the Microbe-cell.) *Arch. de Physiol.*, 1893, pp. 664-72.
- DE FREUDENREICH, ED.—Les microbes et leur rôle dans la laiterie. (Microbes and the part they play in the Milk-Industry.) Paris, 1894, Svo, 2 figs.
- DIETEL, P.—Ueber Uredo Polypodii Pers. *Oesterr. Bot. Zeitschr.*, 1894, p. 46.
- DU CAMP & PLANCHON, L.—Étude Bactériologique de l'eau d'alimentation de Montpellier. (Bacteriological Study of the Drinking Water of Montpellier.) *Annal. d'Hygiène Publ.*, 1894, pp. 224-34.
- DUCLAUX, E.—Le rôle agricole des microbes. (The part played by Microbes in Agriculture.) *Rev. Scientif.*, 1893, pp. 834-8.
- HANKIN, E. H.—On Microbes in Soda-water. *Indian Med. Gaz.*, 1893, pp. 401-3.  
 „ „ An Account of Bacteriological Observations in an Indian Dairy. *Brit. Med. Journ.*, 1894, pp. 181-3.
- IVÁNOFF, M.—Ueber eine neue choleraähnliche Vibrionenart. (On a new Cholera-like species of *Vibrio*.) *Zeitschr. f. Hygiene*, XV. (1894) pp. 434-8.
- JOHNE—Zur Morphologie des Milzbrandbacillus. (On the Morphology of the Bacillus of Splenic Fever.) *Deutsche Tierärztl. Wochenschr.*, 1894, p. 73.
- KLETT, R.—Zur Frage von der Morphologie des Milzbrandbacillus. (On the Morphology of the Bacillus of Splenic Fever.) *Tom. cit.*, pp. 67-8.
- KELLERMANN—Kleine Bakteriologische Studien. (Short Studies in Bacteriology.) *Aerztl. Mitteil. a. und f. Baden*, 1893, pp. 188-91.
- KÜTHE, F. PH.—De ontwikkeling en het tegenwoordig standpunt der bacteriologie. Eerste stuk. (The Development and the Present Standpoint of Bacteriology.) Part 1, Haarlem, 1893, Svo, 153 pp.
- LINDNER, P.—Schizosaccharomyces Pombe n. sp., ein neuer Gärungserreger. (*S. pombe* sp. n., a new Ferment-producer.) *Zeitschr. f. Spiritusindustrie*, 1893, pp. 413-14.
- PAMMEL, L. H.—An Aromatic Bacillus of Cheese, *Bacillus aromaticus* n. sp. Extracts from the *Iowa Agric. Exp. Stat. Bull.* No. 21, 1894, pp. 1-5.
- STRECKLIN, H. DE—Recherches sur la mobilité et les cils de quelques représentants du groupe des Coli-Bacilles. (Researches on the Mobility and the Cilia of some representatives of the Group of Coli-Bacilli.) *Mitteil. a. Kliniken u. med. Instituten der Schweiz. Annal. Suisses d. Scienc. Méd.*, 1. Reihe, Heft 6, 44 pp., 1 pl.



## MICROSCOPY.

## a. Instruments, Accessories, &amp;c.\*

## (1) Stands.

Some Improvements and Additions to the Microscope Stand.†— Herr J. Amann points out some slight improvements and additions to the Microscope stand which might be easily realized without raising the price of the instrument to any great extent.

In the first place, he considers that, at least in the larger stands, the lens-system of the Abbe condenser should be made perfectly centering, and remarks that the centering of the condenser has for a long time past been regarded by English authorities as an indispensable condition for any perfect Microscope.

The method of introducing the polarizer employed in most Continental stands, viz. by supporting it in the diaphragm-holder of the condenser, is also capable of improvement, and a simple arrangement which would allow gypsum and mica plates to be rotated independently of the polarizer in a plane at right angles to the optic axis of the instrument is much to be desired.

A further desideratum concerns the use of the fine-adjustment for exact measurements in the direction of the axis. By long use of a Fuess stand, in which the fine division of the screw-head allowed of readings, with the help of a vernier, of a thousandth of a millimetre, the author has convinced himself that an exactness of from 1 to  $2\mu$  can be attained, and that the usual division of the screw-head into 0.01 mm. is not sufficient to bring out the advantages of the present highly perfect construction of the fine-adjustment. For the coarse-adjustment a division which would allow the displacement of the whole optic system to be measured, would be very useful, e.g. in the determination of the focal length of lens-systems. Such a division could be easily made on the body-tube, while a fixed index, or better still, a vernier, was screwed to the arm which connects the body-tube with the fine-adjustment.

It would be further desirable that in all stands the diaphragm on the lower end of the draw-tube should be provided through an intermediate piece with the English or Hartnack screw, in order to be able to adjust weak objectives on the upper focal plane of the stronger objective which serves for the observation. This simple arrangement serves a number of useful purposes; it allows of the micrometric measurement of the iris of the objective, and thus of the numerical aperture; the observation of the diffraction spectra and that of the axial figures in convergent polarized light; it simplifies further the introduction of an analyser immediately above the objective. This arrangement of the adjustment of the Microscope on the upper focal plane of the objective is besides indispensable in the use of the micro-refractometer.

Finally the author expresses the wish that the lacquer of the lower part of the objective should be replaced by an electro-deposit of platinum

\* This subdivision contains (1) Stands; (2) Eye-pieces and Objectives; (3) Illuminating and other Apparatus; (4) Photomicrography; (5) Microscopical Optics and Manipulation; (6) Miscellaneous.

† Zeitschr. f. wiss. Mikr., xi. (1894) pp. 1-4.

or palladiridium, and better still, that the whole objective and even the whole instrument should be protected from the deleterious effect of chemical reagents by a similar deposit.

### 3) Illuminating and other Apparatus.

**Counting Apparatus specially adapted for Petri's Capsules.\***—Dr. F. Lafar has devised a circular counting apparatus in which the area of the main sectional divisions is equal to 1 qcm. Each of these six divisions has an angle of  $60^\circ$  and these are further subdivided into smaller compartments of  $20^\circ$ , so that the whole field is in 18 divisions. The radii of the circles are 13.8 mm., 27.6 mm., 36.6 mm., 43.7 mm., and 50 mm. Three of  $20^\circ$  sectors are further subdivided by cross lines for counting very closely set colonies.

FIG. 28.

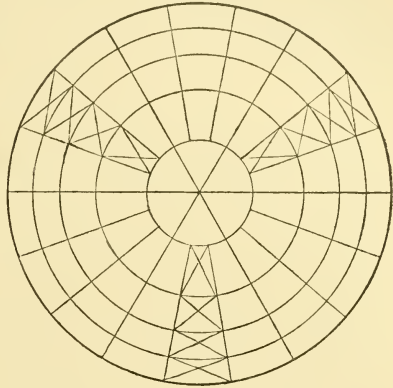

The glass plate in which these lines and circles have been etched is mounted in a circular frame of wood or brass, about 8 mm. high and 9.5 cm. in diameter.

### (4) Photomicrography.

**Photomicrography and Projection.†**—Dr. R. Neuhauss contributes the article on Photomicrography to the Photographic Encyclopædia published by W. Knapp, of Halle a. S. It is intended especially for those who have no time to study the more comprehensive text-books, and yet wish to be instructed in the methods which are proposed to obtain useful photomicrograms by simple means.

**Simple Photomicrographic Camera.‡**—Herr S. Engel has constructed a small camera, resting at right angles on three feet, and considers that the Francotte camera and all other photomicrographic apparatus are greatly inferior to it. Dr. R. Neuhauss, however, states that the Engel model does not differ essentially from apparatus which saw the light forty or fifty years ago, and that the photomicrograms which were taken by Engel with his camera were greatly inferior to most of the photomicrograms taken by others with the Francotte camera and all other photomicrographic apparatus.

**Stereoscopic Photomicrography.§**—Herr Hansemann describes a method for obtaining stereoscopic photomicrograms which is essentially

\* Zeitschr. f. Nahrungsmitteluntersuchung, 1893, p. 429. See Centralbl. f. Bakteriol. u. Parasitenk., xv. (1894) pp. 331-3 (1 fig.).

† Encykl. d. Photographie, W. Knapp, Halle a. S., 1894. See Zeitschr. f. wiss. Mikr., xi. (1894) p. 25.

‡ Berliner Klin. Wochenschr., 1893, No. 47. See Zeitschr. f. wiss. Mikr., xi. (1894) p. 26.

§ Verhandl. der Berliner Physiol. Gesellsch., 1892-3; Arch. f. Physiol., 1893, H. 1, 2, p. 193. See Zeitschr. f. wiss. Mikr., xi. (1894) p. 26.

the same as that employed by Dr. W. C. Borden, as described in the April number of this Journal, p. 262.

**Photomicrograms for Purposes of Instruction.\***—Herr K. Karg recommends the use of photomicrograms for purposes of instruction in preference to the drawings used hitherto. The want of colour is the great drawback, but in spite of this, the beauties of a good photomicrogram are so manifest as to make it preferable to any drawing, even when the latter is really exact.

**Hints on Photomicrography.†**—Those interested in photomicrography should consult Mr. E. M. Nelson's Presidential Address to the Quekett Microscopical Club, where this experienced and expert worker gives some of the results of his work.

(5) Microscopical Optics and Manipulation.

**An Instrument of Precision for producing Monochromatic Light of any desired Wave-length, and its Use in the Investigation of the Optical Properties of Crystals.‡**—Mr. A. E. Tutton has devised an instrument for use in the investigation of the optical properties of crystals, which enables the whole field of any optical instrument whose aperture does not exceed 2 inches to be evenly and brightly illuminated with monochromatic light of any desired wave-length.

In this instrument, which resembles a compact spectroscope in appearance, the exit slit is fixed, while the dispersing apparatus is rotatory.

The apparatus consists of a strong stand, carrying a fixed horizontal circle about which two exactly similar optical tubes are capable of counterpoised rotation. These tubes carry at the ends nearest the centre of rotation lens-combinations of 2 in. aperture and 9 in. focal length, and at the other ends a special form of slit with jaws capable of equal movement on each side of the central line, which thus remains fixed. The lenses of the combinations are not cemented together, but held in metal frames, so that no alum cell is required to protect them from the heat rays.

The dispersing apparatus, consisting of a single 60° prism, with large faces, 4½ in. by 2½ in., is carried by a divided and rotating circle, parallel with and above the fixed circle.

One of the optical tubes is chosen as collimator, and sunlight is reflected along it from a mirror attached to a tapped annulus projecting from the slit frame. The other tube is converted into a telescope by the similar attachment of one of three eye-pieces.\* By the proper adjustment of prism and telescope, it is then possible by rotation of the prism to bring the whole of the spectrum past the exit slit, and to mark the readings of the prism when prominent solar lines are adjusted between the edges of the slit. The mirror and eye-piece are then removed, and by illuminating the receiving slit with any artificial source of light, light of any wave-length may be made to issue from the exit slit by setting the prism to the reading corresponding to that wave-length. The issuing light is diffused by means of a screen of ground glass of fine texture, which is contained in a tube of 2 in. diameter attached to the

\* Verhandl. d. Anatom. Gesellsch. 7. Vers. in Göttingen vom 21-24. Mai 1893. See Zeitschr. f. wiss. Mikr., xi. (1894) pp. 25-6.

† Journ. Quek. Micr. Club, v. (1894) pp. 348-65.

‡ Proc. Roy. Soc., lv. (1894) pp. 111-3.



tapped annulus of the frame of the exit slit. The instrument to be illuminated is brought close up to the diffusing tube, which is best distant about  $1\frac{1}{2}$  in. from the slit.

**The Limits of the Visible.\***—Dr. A. Fock discusses the limits of the power of the Microscope, and in view of recent bacteriological discoveries, seeks to answer the question whether there may not be still many enemies to mankind, which our present Microscopes are unable to render visible.

The magnification of a Microscope depends essentially on three factors, viz. the curvature of the lenses, the degree of perfection in their compensation of the so-called chromatic and spherical aberration, and lastly the angle of aperture of the objective. 

Now the image formed by the Microscope will only perfectly correspond to the object if all the rays into which the incident light is split up by the dispersive effect of the object are again collected by the objective. If this condition is not fulfilled, an image, it is true, will result, but it will not perfectly correspond to the object; and, according as different parts of the pencil are admitted into the Microscope, one and the same object can give quite different images.

The angle enclosed by the rays resulting from diffraction on the object is smaller, the greater the number of diffracting parts. When those parts have dimensions many times greater than the wave-length the diffracted light forms a narrow pencil, and a small angle of aperture of the Microscope suffices in order to receive all the light. But when the dimensions of the parts of the object are comparable to or less than the wave-length, then the diffracted rays may occupy half the angular space. In this case the Microscope can no longer give a perfectly exact image, since the extreme angle of aperture which the objective can give with the help of immersion lenses is  $130^\circ$ .

Our best Microscopes can resolve with central illumination 2500 divisions in 1 mm. Thus, with central illumination the minimum distinguishable distance is 0.0004 mm. or  $0.4 \mu$ . With oblique illumination this can be reduced one-half, and by the use of the ultra-violet rays in producing photographic pictures to  $0.12 \mu$ . All objects and structures then, which do not reach these limits, must for ever remain hidden from the human eye.

Now determinations of the size of molecules, made from the kinetic theory of gases, have given for water the molecular diameter of  $0.00017 \mu$ , and for carbonic acid  $0.00009 \mu$ . The smallest visible object is thus about a thousand times larger than a molecule. From the stand-point of the atomic theory therefore, the existence of an invisible world of life, which would represent a continuation of the micro-organisms known at the present day, is not altogether impossible.

#### (6) Miscellaneous.

**The late Prof. Fol.†**—M. M. Bedot has a biographical notice of our late Honorary Fellow, whose fate will, we suppose, remain for ever wrapt in mystery. Hermann Fol was born near Paris, on July the 23rd, 1845; at Geneva, whence his parents came, he was brought under the

\* Central-Ztg. f. Optik u. Mech., xv. (1894) pp. 76-8.

† Arch. Sci. Phys., xxxi. (1894) pp. 264-83.

influence of the illustrious Claparède, by whose advice he went to Jena to continue his studies under those two great naturalists, Gegenbaur and Haeckel, with whom the biologists of our time will always associate the name of that little German town. In 1866-7, Fol went with Haeckel to the Canary Islands, having for companions Richard Greef and Nicolas de Michelis-Maelay. On his return to Europe, Fol studied at Heidelberg, Zurich, and Berlin, presenting at the last his thesis for the doctorate of medicine in the form of a treatise on the anatomy and development of Ctenophores.

At Messina and at Villefranche he devoted himself to the study of the development of marine Invertebrates, and in 1879 he published his well-known "Recherches sur la fécondation et le commencement de l'hénogénie chez divers animaux." For some time he filled the chair of Comparative Embryology in the University of Geneva.

In bacteriology, photomicrography, and the teaching of histology he took considerable interest, and made important additions to our knowledge.

In 1892 he left Havre in the yacht 'Aster' for the coast of Tunis, but the vessel was never heard of after touching at Benodet.

A bibliographical list of 143 papers is appended to M. Bedot's memoir.

### B. Technique.\*

**Manual of Technique.** †—Dr. D. Luis del Rio y Lara has published a manual of technical micrography. It is prefaced with a commendation from Dr. Ramón y Cajal. The first part deals with instruments, the second with reagents, the rest of the book with special methods. It appears to us to be a terse and clear practical guide.

#### (1) Collecting Objects, including Culture Processes.

**Improvement in J. af Klercker's Arrangement for the Cultivation of Living Organisms under the Microscope.** ‡—Herr A. Scherffel's

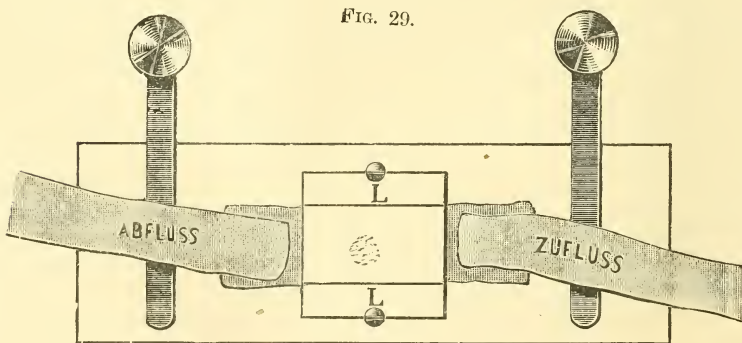

\* This subdivision contains (1) Collecting Objects, including Culture Processes; (2) Preparing Objects; (3) Cutting, including Inbedding and Microtomes; (4) Staining and Injecting; (5) Mounting, including slides, preservative fluids, &c.; (6) Miscellaneous.

† 'Manual de Técnica Micrográfica general,' Madrid, 1893, 8vo, x. and 277 pp., 208 figs.

‡ Zeitschr. f. wiss. Mikr., x. (1893) pp. 441-3 (1 fig.).

modification of J. af Klercker's arrangement consists in substituting for the caoutchouc ring a quickly setting cement with which to fasten on the cover-glass, fig. 29. The disadvantage of the caoutchouc ring was that it prevented the observation of the whole cultivation space, and necessitated the use of a second object-holder, the effect of which was to raise the preparation so far above the stage that the use of the diaphragms was injuriously affected.

By the author's simplification in the mode of fixing the cover-glass it is possible to observe the whole of the cultivation space and to dispense with the second object-holder.

**Apparatus for Cultivating Anaerobic Bacteria.\***—The apparatus devised by Prof. F. G. Novy consists of a cylindrical glass vessel closed by a hollow glass stopper, at opposite sides of which are two apertures (fig. 30). From one of these openings a glass tube runs nearly to the

FIG. 30.

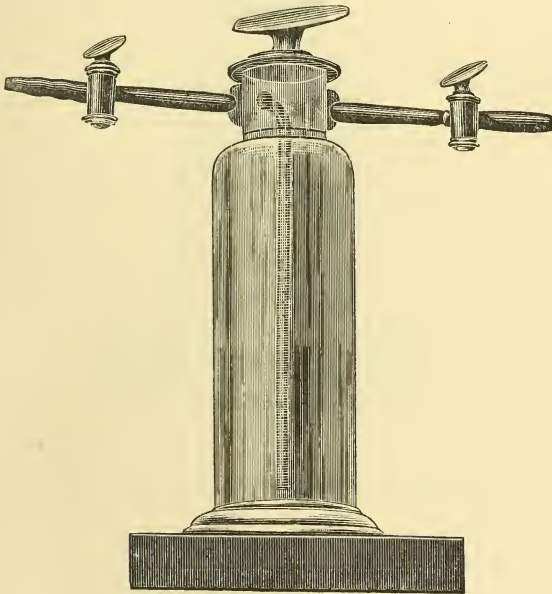

bottom of the flask. From the neck of the flask project at right angles two glass tubes which can be closed by means of stopcocks. The openings of these tubes in the neck of the flask are made to correspond with the openings in the stopper. It is, of course, obvious that if a half turn be given to the stopper the flask will be closed.

The apparatus can be used for anaerobic cultivation either by filling it with some gas or by exhausting the air. The apparatus is used by first putting the inoculated tubes inside the flask. The stopper is then

\* Centralbl. f. Bakteriol. u. Parasitenk., xiv. (1893) pp. 591-5 (2 figs.).

inserted so that the openings therein coincide with those in the neck. The air can then be exhausted by an aspirator attached to one of the tubes or the vessel filled in an analogous way with hydrogen or carbonic acid. If hydrogen, it is advisable to put the gas in at the top and draw out from the bottom, i. e. through the tube opening, and conversely with carbonic acid.

The apparatus is also adapted for the absorption method of cultivation. A strong solution of caustic potash or soda is placed at the bottom

FIG. 31.

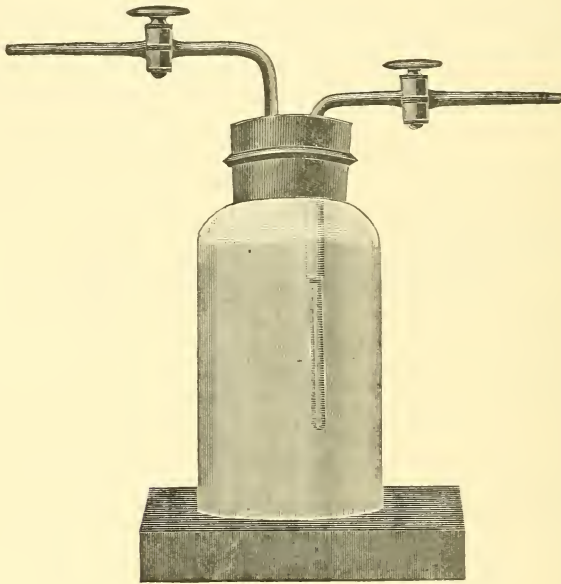

of the vessel, the inoculated tubes are put in, and the stopper having been inserted, a strong solution of pyrogallie acid is aspirated through the tube in the stopper.

A less costly substitute is easily made out of a wide-mouthed bottle fitted with a caoutchouc stopper perforated with a couple of holes, into which are inserted a couple of glass tubes bent at right angles. Both of these are fitted with stopcocks, and one reaches nearly to the bottom of the bottle (fig. 31).

**Apparatus for Bacteriological Examination of Air.\*** — Dr. H. Cristiani describes the following method for examining air obtained at considerable altitudes from a balloon. A flat-bottomed flask is hermetically closed with a rubber plug perforated by two holes for the passage of two glass tubes (fig. 32). The tube *a* is bent, and is stopped in two places with cotton-wool plugs. Its lower leg only just reaches below the

\* Ann. Inst. Pasteur, vii. (1893) pp. 665-71 (1 fig.).



rubber plug. The tube *b* reaches nearly to the bottom of the flask while its upper end is expanded. Over the expansion fits the glass cap *c*, the free end of which is plugged with cotton-wool. This apparatus is termed an *aëroscope*. The bottom of the flask is covered with a layer of nutritive medium composed of 10 grm. bouillon containing 20 per cent. gelatin. The apparatus and its contents having been sterilized in the usual way, the gelatin bouillon layer is covered with a similar bulk of sterilized bouillon. The tube *b* almost, but not quite, touches the solid layer.

A known volume of air, say 10 litres, is drawn through the apparatus by attaching an ordinary pump at *a*. The air bubbles through the liquid medium and deposits its germs there. The two nutritive layers are then melted together by placing the flask in warm water; after which plate or rod cultivations can be made, or what is better, the whole mass may be left in the flask. In the last case the rubber stopper should be replaced by a cotton-wool plug. From the author's experiments made with this apparatus he determined that the atmosphere at an altitude of 1000 metres is extremely pure.

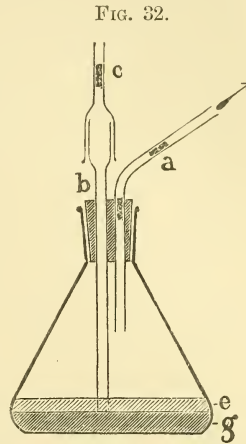

**Absence of Phosphorescence in Cholera Cultures.\***—In the course of some experiments made for comparing the cholera vibrio with other organisms having some resemblance to it, Dr. Kutscher remarked that two cultivations were distinguished by a strong greenish-white phosphorescence. Further observations made on material from various sources such as water, dejecta, &c., established the fact that no considerable number of these vibrios were endowed with phosphorescence, but that in the cholera vibrio this was absent. The optimum temperature for phosphorescence was found to be about 22° C. Hence the absence of phosphorescence may occasionally be found useful as a negative criterion in the diagnosis of cholera.

**Preparation of Nutrient Medium for Bacteria from Eggs.†** — In Koch's original method of employing eggs there was the disadvantage that there was a want of uniformity in the composition of the medium; this has been overcome by Dr. Wesener who mixes the yolk and albumen by shaking the egg before boiling; when the egg has been well shaken it should be placed in water at 75° to 80° C. for 1/2 to 3/4 of an hour. It is then transferred to sublimate solution for cooling and for sterilization of the surface; after drying with sterilized wool the shell and its membrane are removed, when the contents are seen to be of a uniform golden-yellow colour. Three or four slices are cut with a sterilized knife, placed in Esmarch's dishes, and sterilized as usual. Among the advantages of this medium are its alkaline reaction, its richness in albumen, and the fact that it is unfavourable to the growth of moulds.

\* Centralbl. f. Bakteriol. u. Parasitenk., xv. (1894) pp. 44-6.

† Centralbl. f. Allgem. Path., Jan. 1894; see Brit. Med. Journ., No. 1736, 1894, p. 56.

**Cultivation of Cholera in Uschinsky's Medium.\*** — Dr. O. Voges finds that Uschinsky's medium (see this Journal, 1893, p. 796) is eminently suitable for the cultivation of cholera, and in many respects decidedly superior to the pepton solution. The experiments showed that cholera bacilli not only formed a fine scum after eight hours' incubation, but that with the exception of *Bact. coli*, other organisms had little tendency to develop and thus complicate the process as they do with the pepton solution. In other words the cholera bacillus can exist on a more scanty diet than many other organisms and are therefore found to predominate. The experiments were conducted in three stages, the first cultivations being made in test-tubes, the second on gelatin plates in Petri's capsules, and the third in Erlenmeyer's flasks in order to ascertain the behaviour when large quantities of the medium and of the material to be consumed were used.

When prepared in large quantity the author found that the medium became cloudy and threw down a precipitate of calcium chloride. This was purposely omitted after it was found that the cholera bacillus thrived equally well without it.

The author further found that the medium could be adapted for the examination of water suspected of containing cholera germs. As ordinary water contains the salts suitable for the cholera bacillus it was merely necessary to compose a medium of the following composition:—sodium chloride 4, biphosphate of potash 1, lactate of ammonium 3, asparaginate of soda 2, are dissolved in 100 aq. dest. and the mixture sterilized. By adding 400 ccm. of the water to be examined to this solution a fluid of similar composition to the original Uschinsky's medium is obtained. It is not, however, necessary that a special solution should be made, it is quite sufficient to put the salts alone in the water to be examined.

The chief merit of this medium is that after an incubation of eight to ten hours a thick scum of cholera vibrios in almost pure cultivations is obtained. By admixture with 2 per cent. of agar a good solid medium is obtained and on this the cholera colonies grow readily and in characteristic shape. One peculiarity of this medium is noticeable, it never gives the indol reaction.

**Obtaining Germ-free Blood-serum.†**—It is of the greatest importance to obtain blood-serum quite uncontaminated by mixture with air, says Dr. J. Kuprianon, as then its qualities need not be damaged by the action of heat or disinfectants. A sheep is brought into the laboratory and having been properly fixed the neck is shaved, and the vein and artery are exposed with the usual precautions. The blood is received into flasks holding about 1 litre; these are stopped with caoutchouc plugs in which are two holes for the passage of glass tubes. One of these, bent at a right angle, is joined on to a rubber tube, to which is fixed a glass cannula. The vein or artery having been clamped the cannula is inserted into the distended part of the vessel and then ligatured. The other tube is stopped with cotton wool. It may be necessary to use several cannulas as they occasionally break. When the blood ceases to flow

\* Centralbl. f. Bakteriol. u. Parasitenk., xv. (1894) pp. 453-7.

† Tom. cit., pp. 458-62 (2 figs.).

from the vein or chokes the cannula, the artery is tried. In this way a large quantity of perfectly germ-free blood is obtained.

The flasks containing the blood are to be kept in a cool place, and by the next day the pale red clear serum has separated. This is removed from the flasks into similar vessels by siphoning the serum from a first flask into another empty one. Air contamination is prevented during this procedure by joining the flasks with a rubber tube, which passes by the intervention of glass tubing through the stopper of one vessel into that of the other. The end of this tube dips into the serum of the first tube. Each stopper has another perforation through which passes a glass tube plugged with cotton wool for filtering the air. If the blood have been carefully taken, and the vessels filled without a mistake, serum thus obtained can be kept for a long time. The quantity of blood obtainable from a lamb weighing 50-60 lbs. amounts to 2-2½ litres, and the blood-serum from this is about 700-800 ccm.

In order to distribute the serum into test-tubes without being contaminated, the author uses the following apparatus. A burette, the upper opening of which is stopped with cotton wool, is connected below with a glass Y-tube, the other two arms of which are joined by clamped rubber tubes; one of these is long and connects with the glass tube dipping into a serum flask. The serum from the flask is put into the burette by siphon action and when a sufficient quantity is obtained the connecting tube is clamped, and then the other tube from which the tubes are to be filled is unclamped, and so on.

## (2) Preparing Objects.

**Technique for Studying Tubercle Bacilli in Lung.\***—Dr. A. Borrel, who has been studying pulmonary tuberculosis after intravenous injection, recommends as fixative saturated aqueous solution of sublimate to which 5 per cent. glacial acetic acid has been added, or a mixture of sublimate and Flemming's fluid. The whole of the lungs are immersed for five or six hours in the fixative, they are then incised to aid the penetration of the fluid. Fixation is complete in about 12 hours. From the sublimate the pieces are transferred at intervals of 24 hours to alcohols of increasing strength (50, 80, 96, 100), after which they are immersed in toluene for 24 hours, then in a mixture of equal parts of paraffin and toluene and finally in paraffin. The sections are fixed to the slide and stained by a method devised by Kühne of Wiesbaden, not published but communicated orally to the author. It consists in using hydrochlorate of anilin (salzsaures Anilin) as a decolorant, and its special advantages are that it is less harmful to the tissues than acids, and while it will decolorize the tissues in a few seconds it does not remove the stain from tubercle bacilli. The preparations are stained for 10-15 minutes in Ziehl's solution and then treated with an aqueous 2 per cent. solution of anilin hydrochlorate. They are then differentiated and dehydrated in alcohol and mounted in balsam, or the following procedure may be adopted:—(1) Stain the sections in hæmatoxylin or better still in hæmatein. The latter is preferable and the solution is thus made:—(A) dissolve 50 grm. of alum in 1000 grm. water by aid

\* Ann. Inst. Pasteur, vii. (1893) pp. 593-627 (3 pls.).



of heat; (B) dissolve 1 grm. of hæmatein in 50 grm. absolute alcohol. Mix the two while still warm, allow to cool and filter. (2) Wash in water; (3) stain with Ziehl 15 minutes; (4) anilin hydrochlorate 2 per cent. a few seconds; (5) decolorize in alcohol; (6) xylol; (7) balsam.

After decolorizing the preparation may be contrast-stained in aqueous solution of aurantia or of Indian yellow in order to show up the red corpuscles in the blood-vessels and the protoplasm.

**New Method for Detecting Tubercle Bacilli in Phthisical Sputum.\***—Dr. K. Ilkewitsch dilutes about  $1/2$  ccm. of sputum with 20 ccm. distilled water and some drops (8–12) of a 30 per cent. solution of KHO. When by the aid of heat and constant stirring the sputum is completely dissolved, some casein, which has also been dissolved by heat-stirring, and 1–2 drops of KHO, are added. This imparts a milky appearance to the hitherto transparent fluid. The mixture is then poured into a test-tube, a few drops of acetic acid are added, and the whole is transferred to a brass tube (about 20 ccm. contents), the end of which is conical. The tube is then fixed in the centrifuge by means of a special apparatus devised by the author, but which is unimportant so far as the principle of the process goes. After centrifuging for 5–10 minutes the sediment which has collected in the conical end is removed by unscrewing the cap. The cap is just like the end of a pencil or stylograph, and the sediment is prevented from escaping by dropping down a little ball which shuts it in during removal. The sediment is then removed, spread on cover-glasses and treated in the usual manner.

The principle on which the foregoing method is founded is derived from the fact that casein of milk (lactoglobulin) is of all proteids the most sensitive to the action of acetic acid. Hence in this mixture of casein, sputum, and acetic acid, the casein is the first to coagulate, and accordingly, after centrifuging, so much sediment is obtained as casein has been added.

**Investigation of Blood of Necturus and Cryptobranchus.†**—Miss E. J. Claypole prepared the tissues of these Amphibians by hardening them according to Prof. Gage's picric-alcohol method—95 per cent. alcohol 250 ccm.; water 250 ccm.; and picric acid crystals 1 grm. After two or three days the animal was transferred to 67 per cent. alcohol for from 24 to 36 hours, and then placed in 82 per cent. alcohol. For imbedding, small pieces were dehydrated in 95 per cent. alcohol for 12 to 24 hours, soaked in chloroform for the same time, infiltrated four to five days in an incubator, and imbedded in pure, hot paraffin. For acid staining, hydrochloric acid carmine was found to be most successful.

**Investigation of Ancyclus.‡**—M. E. André found grave disadvantages in the two methods often recommended for fixing Gastropods—the use of picro-sulphuric acid or boiling sublimate. He found that he got the best results by placing the animals on their ventral surface on the bottom of a capsule containing a very little water, and then killing them by suddenly adding boiling water. They should then be placed in a tepid

\* Centralbl. f. Bakteriol. u. Parasitenk., xv. (1894) pp. 162–5.

† Proc. Amer. Micr. Soc., xv. (1893) pp. 66 and 7.

‡ Rev. Suiss. Zool., i. (1893) pp. 429–31.



fixing liquid containing 90 parts of saturated solution of bichloride of mercury and 10 parts of glycerin. After staying in this for a quarter of an hour the animals may be treated with a series of alcohols, beginning with alcohol at 70° containing in solution a small quantity of camphor. Borax-carminé was found to be the best stain.

**Development of Cirripedia.\***—Mr. T. T. Groom was able to trace in watch-glasses part of the development of ova of Cirripedes obtained by direct removal from the ovaries, but after a certain time the process invariably ceased; the cause of this could not be discovered. Most of the embryos were sufficiently transparent to show most of the details of their anatomy by transmitted light; Abbe's condenser was frequently found to be of considerable assistance, the oblique light often being very necessary in order to make out the cell boundaries.

For the histology of the embryos picro-nitric, picro-acetic, and picro-sulphuric acids and Perenyi's fluid were good. For examination of unstained Nauplii weak osmic acid, as recommended by Dr. Koch, was found useful, as was also weak iodine. Embryos preserved with corrosive sublimate or with Perenyi's fluid stained well with borax-carminé, but those that had been treated with chromic acid were difficult to stain, as might indeed be expected.

A useful table is given of the months in which eggs, Nauplii or Cypris-stages have been obtained by the author or others.

**Preparing and Staining Cover-glass Preparations.†**—Dr. A. A. Julien describes at some length procedures for obtaining undistorted and well stained preparations of micro-organisms and their cilia, and suggests that the dried bacterium film should be obtained in the following way:—A drop of the cultivation is to be diluted with sterilized distilled water. Some of this fluid is distributed on cover-glasses and the organisms there killed and fixed by the addition of some suitable reagent (e. g. tannin or chromic acid). The covers are allowed to dry slowly and at a low temperature. Before staining the film is treated with some mordant. The mordant recommended is a mixture of tannin and acetate of iron. (To 10 ccm. of 20 per cent. aqueous solution of tannin a solution of acetate of iron is added until it becomes violet-black; then add 5–10 drops of acetic acid, and 4 ccm. of 12 per cent. carbolic acid, and filter.) For staining the films, a solution is made by mixing 100 ccm. of anilin with 1 per cent. sodium hydrate added drop by drop until a neutral reaction is obtained. Then 1/2 grm. of fuchsin is dissolved therein, with shaking. The solution must be filtered before using, and when it loses colour more fuchsin must be shaken up with it.

The author lays considerable stress on two points, rapid fixation and slow drying of the film.

### (3) Cutting, including Imbedding and Microtomes.

**New Double-knife.‡**—Herr P. Schiefferdecker describes a new double knife made by W. Walb, of Heidelberg. As seen in fig. 33 the blades have the razor form. The handle, which like the blades is

\* Phil. Trans., 183 B. (1894) pp. 122–5.

† Journ. New York Micr. Soc., x. (1894) pp. 1–14.

‡ Zeitschr. f. wiss. Mikr., xi. (1894) pp. 4–5 (1 fig.).

nickel-plated, consists of the two shanks belonging to the two blades, and a metal piece between them, which in longitudinal section forms a very acute-angled isosceles triangle. To the base of this is attached a rod provided with a screw-thread which works in a nut at the end of the handle. By means of the screw the rod and, with it, the metal prism can be moved up and down; the effect of this is to separate the

FIG. 33.

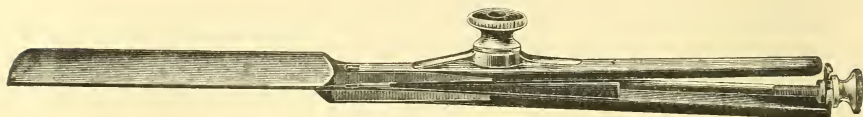

knife-handles, and therefore also the blades, more or less apart. A second nut at the side, by means of a strong spring acting on one handle and a pin on the other, serves to fix the blades in the required position, and at the same time to make them practically parallel. The parallel position is not mathematically exact, but is sufficiently so for many purposes. The knife can be easily taken to pieces to be cleaned.

**Imbedding Delicate Objects in Celloidin.\***—Dr. A. Elsching recommends that very delicate objects should be immersed in thin celloidin solution for 3–8 days. They are then placed in a glass capsule on the bottom of which the necessary description has been already marked with a coloured oil-pencil. Thick celloidin solution is then poured over them and the capsule closed with a glass plate smeared with thin celloidin solution. This effectually excludes the air, though it is advisable to cover the apparatus with a bell-jar in case of accidents. In 24 hours air-bubbles are removed by turning the preparation over with a needle dipped in the thin solution, and then reclosing the capsule as before. After a few hours, all the air-bubbles will have disappeared and then the capsules may be closed with a dry glass plate. In a few days the celloidin will have become stiff enough to be completely set in 85 per cent. spirit.

**Air- and Water-free Celloidin Solutions.†**—It is important, says Dr. A. Elsching, that celloidin solutions should be free from air and water. To effectually deprive celloidin of water, the tablets should be cut up into little blocks, the sides of which are not bigger than 5 mm. These are placed between folds of blotting-paper, and first allowed to dry at the room temperature, and then desiccated in an incubator. At this stage they should be of a yellowish hue and of horny consistence. Absolute alcohol may be easily obtained entirely free of water, by repeated treating with freshly dried copper sulphate. The dried cubes are placed in a narrow-necked bottle, with air-tight stopper, and form a layer not exceeding one-fourth the volume of the bottle. The celloidin is then just covered with absolute alcohol, and allowed to stand for about 24 hours, after which the ether is poured in. In a very short time the celloidin is all dissolved, and thus, as no stirring is required, the solution is kept free of air-bubbles.

\* *Zeitschr. f. wiss. Mikr.*, x. (1893) pp. 445–6.† *Tom. cit.*, pp. 443–5.

## (4) Staining and Injecting.

**Use of Thionin.\***—Dr. Kantorowicz recommends thionin, which is related to methylen-blue, for staining tissues affected by amyloid changes. While ordinary cells, nuclei, and connective tissue are stained blue or violet-blue, amyloid material stains a light blue or lilac. Preparations should be hardened in alcohol or sublimate, and imbedded in celloidin; sections, after being in 80 per cent. alcohol and washed in water, should be placed for from three to five minutes in a saturated aqueous solution of thionin. The tint may be preserved by removing the section from water to a slide, drying with filter-paper, and dehydrating and cleaning by means of a mixture of anilin oil and xylol (2 parts to 1), or carbolic acid and xylol (1 to 3). Wash off the mixture with xylol and mount in dammar; in other words, avoid alcohol.

**Formic Acid Hæmatoxylin.†**—Dr. G. Pianese commends the following hæmatoxylin stain, which is made by mixing 6 ccm. of a saturated alcoholic solution of hæmatoxylin with 50 ccm. of a saturated aqueous solution of alum. The solution is exposed to daylight for eight days, and then 20 ccm. of formic acid and 5 ccm. neutral glycerin are added and the mixture filtered. The solution is quite clear and of a reddish hue. It is said to give excellent results in the examination of nerves and their finest ramifications, though, of course, as might have been expected from its composition, it is valuable as a general stain.

**New Method of Staining Cilia of Bacteria.‡**—M. E. Van Ermengem recommends (1) washing of slides in a solution of 60 grm. bichromate of potash, 60 grm. of concentrated sulphuric acid, and 1000 grm. water; (2) recent agar-cultures; (3) a fixing-bath of 1 part of 2 per cent. solution of osmic acid and 2 parts of a 10 to 25 per cent. solution of tannin, to every 100 ccm. of which 4 or 5 drops of acetic acid may be added. This mixture forms a black ink, a drop of which should be left on the slide for from 5 to 30 minutes according to the temperature. The preparations, after washing in water and in alcohol, should be placed in a nitrate of silver bath (0.5 to 0.25 per cent.). They should then be put into a bath of 5 grm. gallic acid, 3 grm. tannin, 10 grm. acetate of soda, and 330 grm. of distilled water. After a few seconds, replace in silver bath, wash, and mount in balsam.

**Method for Staining Flagella.§**—Sig. Sclavo states that the flagella of certain micro-organisms are easily stained if cover-glass preparations be treated in the following way. (1) One minute in tannin solution (tannin 1.0 in 100 ccm. of 50 per cent. alcohol). (2) Wash in distilled water. (3) One minute in 50 per cent. phosphomolybdic acid. (4) Careful washing in distilled water. (5) 3–5 minutes in warmed staining

\* Centralbl. f. Allgem. Path., Feb. 1894. See Brit. Med. Journ., No. 1736 (1894) p. 56.

† Giornale Internaz. Sci. Med. Napoli, xiv. (1892) pp. 881–94. See Zeitschr. f. wiss. Mikr., x. (1893) p. 501.

‡ Ann. Soc. Med. Gand, June 1893. See Bull. Soc. Belg. Micr., xx. (1894) pp. 29–32.

§ Ministero del Interno: Laboratori Sci. d. Direz. di Sanità, Roma, 1893. See Centralbl. f. Bakteriolog. u. Parasitenk., xv. (1894) pp. 507–8.



solution of powdered fuchsin dissolved to almost saturation in anilin water and filtered. (6) Wash in distilled water. (7) Dry on blotting-paper and mount in balsam.

By this method the author stained the flagella of *Bac. cyanogenes*, *Proteus vulgaris* and *mirabilis*, *Bac. megaterium*, *mesentericus vulgatus*. With the "typhoid" group the results were variable and inconstant; thus, with *Bac. typhosus* the flagella sometimes stained and sometimes did not. Among the "typhoid-like" bacteria some varieties stained and others did not. The method failed with *Bact. coli*, and the Spirilla of Koch, Metschnikoff, Prior-Finkler and Deneke, though beautiful flagella were seen in some water-organisms.

**Staining Flagella.\***—MM. M. Nicolle and V. Morax have simplified the somewhat complicated procedure invented by Loeffler for staining the flagella of vibrios. A small piece taken from a recent agar cultivation is placed in a watchglassful of tap-water; the mixture should be only just cloudy. Some of this fluid is spread on clean cover-glasses which have been further purified by passing them frequently through the flame. The cover-glass held with forceps by the edge is inclined at an angle, and the superfluous fluid removed by means of a pipette. It is then allowed to dry without fixation in the flame. The surface is then covered with the mordant (aqueous solution of tannin 20 per cent., 10 ccm.; aqueous solution of cold saturated ferrous sulphate, 5 ccm.; saturated alcoholic solution of fuchsin, 1 ccm.) and heated for 10 seconds. When the fluid begins to vaporize the mordant is tossed off and the surface washed by a stream of water from a dropper. The mordanting and washing are repeated three or four times more. After each washing the under surface of the cover-glass should be dried carefully. The preparation is next stained with phenol-fuchsin and heated once or twice for a quarter of a minute. It is then washed and examined in water. If the staining have been successful the cover-glass is dried and mounted in balsam.

The points on which the authors lay most stress are that the cover-glasses should be perfectly clean, the mordant applied several times, and that the tannin must be pure.

**Staining Nuclei of Anthrax Spores.†**—Dr. W. Ilkewicz has succeeded in staining the nuclei of anthrax spores by a modification of Kolosow's method, which consists in first treating the preparation with osmic acid and afterwards with tannin or pyrogallic acids. The details of the process are as follows:—The cover-glasses smeared with anthrax are first fixed in the flame and afterwards in the osmic acid mixture, heated until the fluid begins to vaporize. It is then washed and treated a second time in the same way and afterwards goes through a similar process in the reducing fluid. It is then dried and examined in glycerin or balsam.

The fixative is composed of 7 ccm. of a 1/2 per cent. osmic acid solution and 3 ccm. of formic acid. Kolosow's reducing fluid is made by dissolving 30 gm. tannin in 100 ccm. of distilled water and allowing this to stand in an open vessel for 24 hours. It is then filtered and the filtrate mixed with 30 gm. pyrogallic acid dissolved in 100 ccm. distilled water. The mixture is further diluted with 250 ccm. distilled

\* Ann. Inst. Pasteur, vii. (1893) pp. 554-61 (15 figs.).

† Centralbl. f. Bakteriol. u. Parasitenk., xv. (1894) pp. 261-7 (1 fig.).



water, 100 ccm. 85 per cent. spirit, and 50 grm. glycerin. This was modified by the author in the following way; instead of 85 per cent. spirit, 95 per cent. was used, and then with the original reducing fluid two different solutions made. One of these consisted of equal parts of Kolossow's fluid and a mixture of 8.0 pyrogallic acid, 3.0 citric acid, 17.0 natrum sulfurosum, and 150.0 distilled water. The other was composed of 10 ccm. of the Kolossow solution, 3 ccm. spirit, 2 ccm. 20 per cent. tannin, and 1 ccm. glycerin.

**Microchemical Staining Reactions of Mucin.\***—Besides the already known microchemical staining reactions for mucin, Sawtschenko proposes the following:—Hardening in sublimate; staining with borax-carmin followed by Gram. The smallest particles of mucin, the mucous degeneration of cells of mucous glands, the contents of cancer cells simulating Coccidia and designated by some Sporozoa, assume when stained by this method a deep violet-blue hue, while the capsules of these bodies, as well as the whole of the protoplasm of the cells, are of a pink or red hue.

**Weigert's Fibrin Method.†**—Dr. S. Ehrmann points out that his previous work on pigmentation has not been duly recognized by Kromayer in his recent application of Weigert's fibrin-method. What is new in Kromayer's communication is the conclusion that the pigment-lines in the epithelial cells represent a breaking-down of the protoplasmic fibres, and this, Ehrmann says, is not true. He believes that the blood-pigment is the material out of which the cell-protoplasm forms the pigment just as the plasmodium malariae forms melanin. Ehrmann discusses Weigert's method in some detail and has further criticism of Kromayer's work.

(5) Mounting, including Slides, Preservative Fluids, &c.

**Slide-holder.‡**—Dr. Fabre-Domergue has devised a contrivance for holding a number of slides, so that the preparations thereon may be treated by various fluids or reagents without disturbance, and with little trouble and loss of time.

It is a disc of copper, 40 mm. in diameter, on the surface of which are soldered six metal clips. The clips are simply brass plates bent on themselves into a U-shape. In these clips the slides are slipped and fixed with Mayer's albumen and heat. The slide-holder is then transferred successively to a series of bottles containing the various stains and re-agents. These bottles are 85 mm. high and 35 mm. broad, and are placed in a common wooden support.

\* Centralbl. f. Bakteriol. u. Parasitenk., xv. (1894) p. 485.

† Arch. f. Mikr. Anat., xliii. (1894) pp. 79-95.

‡ Annales de Micrographie, vi. (1894) pp. 84-6 (1 fig.).

FIG. 34.

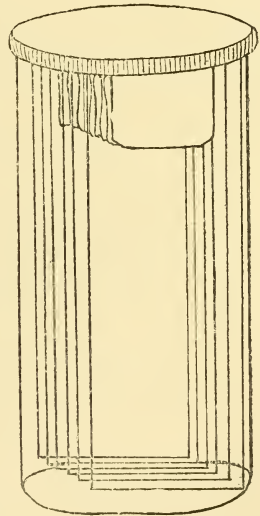

## (6) Miscellaneous.

Drawing imperfectly visible Details with Camera lucida.\* — Dr. J. W. Chr. Goethart uses red-tinted paper for drawing with the camera lucida, and thus obviates the inconvenience arising from the glare of the paper which, under high powers especially, often renders the picture or its details difficult to be seen. One volume of a saturated alcoholic solution of fuchsin is mixed with two or three volumes of 96 per cent. spirit, and the sheets of drawing-paper are immersed in the solution for a few seconds. The paper is then hung up by one corner to dry. After drawing the paper may be decolorized by immersing it in 1-2 per cent. solution of nitrite of potash or soda, to which, while the dish is being moved to and fro, a small quantity of sulphuric acid is gradually added. At a temperature of 40-50° decoloration rapidly ensues, while at room-temperature it is rather slow. As soon as the paper assumes a light yellow tone it is to be carefully washed in clean water, and then dried. The point of the lead pencil should be painted white.

\* *Nederlandsch Kruidkundig Archief*, vi. (1892) pp. 161-5. See *Zeitschr. f. wiss. Mikr.*, x. (1893) p. 467.

---

## PROCEEDINGS OF THE SOCIETY.

## THE CONVERSAZIONE.

THE CONVERSAZIONE was held on April 4th, 1894, in the Town Hall of St. Martin's-in-the-Fields, Charing Cross, W.C., and was attended by 378 persons. The following is the list of objects exhibited at the Meeting:—

J. M. Allen, Esq.:—Rotifera: *Brachionus pala*, *Asplanchna priodonta*, *Conochilus*.

Rev. G. Bailey:—Foraminifera from the Neocomian Clay: *Pleurostomella*, *Vaginulina*, *Ammodiscus tenuis*, *Cristellaria*, &c.

Messrs. C. Baker & C. Lees Curties:—Arranged Diatoms, Scales, &c., by E. Thum, Leipzig. Diatoms on Coralline. *Podura* Scale, green screen—Leitz Pantachromatic 1/8 N.A. ·87, Abbe Achromatic Condenser. Pond-life. Arranged Diatoms—Zeiss Apochromatic 1 in. N.A. ·30, Abbe Achromatic Condenser; *Coccinodiscus asteromphalus*, fracture through secondary markings—Zeiss Apochromatic 1/8 N.A. 1·40, Abbe Achromatic Condenser.

Messrs. R. & J. Beck:—Cheese-mites; *Daphnia vetula*; *Diaptomus Castor*.

W. Burton, Esq.:—Rotifera: *Asplanchna*, *Brachionus*, &c.

Mons. A. Certes:—*Spirobacillus gigas* Certes, from the water-supply of Aden.

W. J. Chapman, Esq.:—Rotifera: *Brachionus quadratus*, &c.

H. G. Coombs, Esq.:—Larvæ of Lobster.

T. R. Croger, Esq.:—Vertical Section of *Æcidium*; Group of Seeds.

E. Dadswell, Esq.:—*Frustrella hispida*; *Coryne fruticosa*.

C. G. Dunning, Esq.:—*Limnocodium Sowerbii*, Royal Botanic Gardens, April 1888; *Serialaria lendigera* with polyyps expanded.

F. Enock, Esq.:—Fairy Fly, *Camptoptera*. These flies lay their eggs in those of injurious insects.

T. D. Ersser, Esq.:—Frog's Foot showing the circulation, the corpuscles magnified about 450 times—1/7 Ob., B eye-piece.

J. W. Gifford, Esq.:—*Surirella gemma* (axial illumination) in realgar, Spectrum of Malachite-green, glycerin screen.

Commander C. E. Gladstone, R.N.:—Young Sole.

F. Goddard, Esq.:—*Lophopus crystallinus*.

J. G. Grenfell, Esq.:—*Oscillatoria* Tracks and Diatom Threads and Films.

H. Groves, Esq.:—*Nitella flexilis*, showing cyclosis.

J. D. Hardy, Esq.:—Marine Life, &c.

Dr. Hebb:—The, "Cancer Parasite" × 600; Psorosperms from Rabbit's Liver; Leukhæmic Blood; Bacilli of Leprosy in Nerve.

F. W. Hemby, Esq.:—*Cladonia coccinea*; *Lamium album*.

E. Heron-Allen, Esq.:—Foraminifera from Torres Straits, 80 varieties.

Rev. R. Hollis:—An African Diamond in the rough condition.

- Messrs. W. Johnson & Sons:—Advanced Students' Microscopes; *Filaria sanguinis hominis*; Anthrax Bacilli; Larva of *Anthomyia*; Young Star-fish; Head of *Syrphus ribesii*; Spicules of *Synapta*.
- G. C. Karop, Esq.:—Transverse Section of Echinus Spine (*Echinothrix* ?); Chromatoscope.
- T. J. Lambert, Esq.:—Indian Tortoise Beetle; Head of Earwig.
- R. T. Lewis, Esq.:—Eggs and Larvæ of Hemiptera from Natal.
- R. Macer, Esq.:—A living Blow-fly.
- G. Mainland, Esq.:—*Asterina gibbosa*.
- Marine Biological Association (Dr. G. H. Fowler):—Crustacea Decapoda, and Mollusca Nudibranchiata—Collection illustrating the Plymouth Fauna. Collection of Oysters (*Ostrea edulis*), showing local variations.
- H. S. Martin, Esq.:—Precious Opal from Queensland.
- The President (A. D. Michael, Esq.):—A new and undescribed Acarus from New Zealand, intended to be called *Notaspis spinulosa*. Eggs of the Stone-mite (*Petrobium lapidum*); these eggs appear suddenly, generally in a single night, and often cover large districts; the specimens came from near Bath, where 12 acres were covered as thickly as the stone shown. They may not appear again for many years. *Plumularia setacea* with extended tentacles as in life.
- H. Morland, Esq.:—Starch-grains of *Euphorbia splendens*; *Syndetoneis amplexans*.
- E. T. Newton, Esq.:—Kerosine Shale with *Reinschia*.
- Messrs. Newton & Co.:—Triple Rotating Electric Lantern. (Figs. 35 and 36.)
- The body of this instrument is made entirely of bronzed brass, mounted on four brass pillars and mahogany stand; the base is fitted to a traversing table of polished gun-metal and steel, and has screw movements for centering the arc light and for keeping it centered during use. There are three fronts to the lantern, each placed at an angle of 120 degrees from each other; between each front is a door and sight-hole through which the light may be observed. The front on the left carries a 4½-in. condenser with slide-stage and double achromatic objective for exhibiting ordinary slides and diagrams. The second front is also fitted with a 4½-in. double condenser for parallel beam work, and has a slit front having screw motions and rotating diaphragm. The third front carries the Microscope and micro-polariscope (fig. 36), and is fitted with quadruple 5-in. primary condensers, alum-cell, rotating stage, diaphragms, coarse- and fine-adjustments, and rotating polarizing and analysing prisms, &c. All the parts are interchangeable, and are so arranged that the instruments can be bolted on at will.
- W. J. Parks, Esq.:—Water-flea, *Daphnia pulex*; House-fly.
- F. A. Parsons, Esq.:—*Perophora Listeri*; *Daphnia Schæfferi*; Larvæ of *Corethra plumicornis*.
- Dr. H. G. Plimmer:—Living Cultures made by Dr. Král, of Prague, of Non-pathogenic Micro-organisms, and of the Bacilli of



FIG. 35.

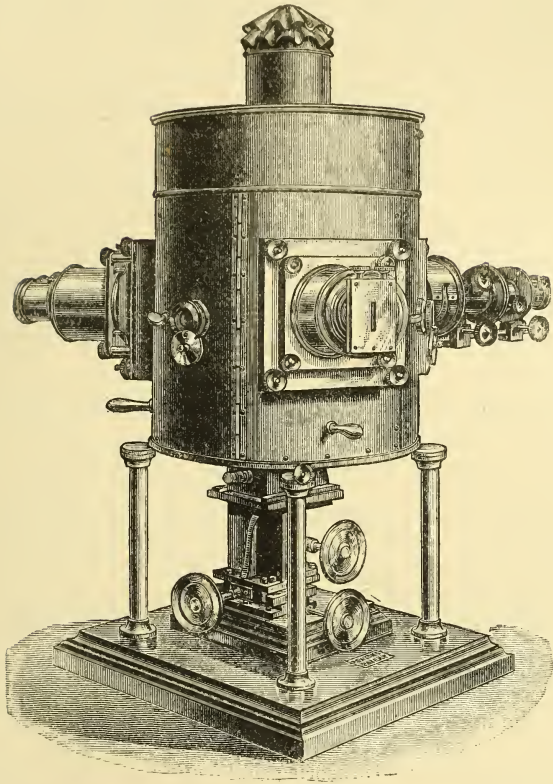
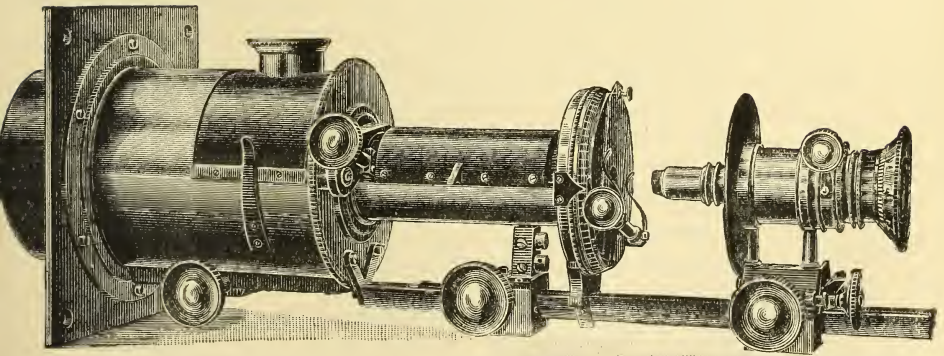

FIG. 36.



Third front.

Tubercle (Consumption), Influenza, Whooping-cough, Thrush, and of various other Pathogenic Bacteria. Protozoa found in Cancer; Flagella of *Spirillum undula*; various Pathogenic Micro-organisms.

T. H. Powell, Esq.:—Circulation in *Vallisneria* with 4/10 Apochromatic Objective, 1/4 Eye-piece, and Dry Apochromatic Condenser.

B. W. Priest, Esq.:—Fossil Sponge Spicules; Sponge—*Lanuginella pupa* Schmidt, 'Challenger' Expedition, Station 192.

J. W. Reed, Esq.:—Puckered Schist from Rocks above the Garner Glacier, Zermatt; Granitite from Montanvert; Gneiss.

F. Reeve, Esq.:—Stem of *Eucalyptus globulus*; Stem of *Andromeda floribunda*; Stem of *Pteris aquilina*.

C. F. Rousselet, Esq.:—Micro-aquarium and Aquarium Microscope; Rotifera and Infusoria; Preserved and Mounted Rotifers: *Melicerta ringens*, *Limnias ceratophylli*, *Stephanoceros Eichhornii*.

D. G. Simpson, Esq.:—*Salticus*, Eyes, &c. (Jumping Spider); Arranged Diatoms; Mildew on Wheat (*Puccinia graminis*).

A. Smith, Esq.:—*Bostrychia scorpoidea* with Tetraspores.

G. J. Smith, Esq.:—Rock Sections under polarized light: Andesite from Kremnitz, Hungary, Melaphyre (Palatinite) from Martinstein, and Mica Schist from the Malvern Hills.

A. W. Stokes, Esq.:—Menthol, with a little Fatty Acid (polarized).

W. T. Suffolk, Esq.:—Lips and Mouth of Blow-fly killed with chloroform while feeding.

Messrs. J. Swift:—Alloxanate of Ammonia; Oxalate of Soda; Platinocyanide of Strontia.

J. Terry, Esq.:—*Conochilus volvox*.

J. J. Vezey, Esq.:—Specimens of elaborate mounting: A vase of flowers—the flowers composed of scales from the wings of butterflies, the vase composed of diatoms.

H. J. Waddington, Esq.:—Infusoria: *Folliculina ampulla*; Coelenterata: *Hydra tuba*, Strobila and Ephyra forms; Ascidia: *Perophora Listeri*; *Clavellina* just commencing development from winter stage; Annelida: *Cirrhatus*, &c.; Nudibranchiata: *Doris tuberculata*, the embryos almost mature; Preserved specimens of *Asterina gibbosa* at various stages.

For preserving the *Asterinæ* as permanent objects and at any stage of their development, the best method is to use cocaine hydrochlorate and to allow them to come under its influence very gradually. In this way they die without undergoing any distortion, and may be transferred to weak alcohol of 30 or 35 per cent., and preserved in this fluid, or carried through higher percentages of alcohol to oil of cloves, this removed with re-distilled turpentine, and then mounted in Canada balsam.

Messrs. W. Watson & Sons:—Palate of *Haliotis*; *Actinomyces* in Tongue of Cow; Scales and Hairs of Insects arranged as a "Wreath of Flowers"; Winter Bud of Plane-tree; Type-slide of Eggs of Butterflies and Moths; Group of Diatomaceæ from Japan; Young Lobster; Parasol Ant from Trinidad; Bacillus of Leprosy in Section of Skin.

- W. West, Esq. :—Tube-building Rotifer, *Melicerta ringens*.  
 G. Western, Esq. :—Rotifera: *Melicerta tubicularia*, *Hydatina senta*,  
*Conochilus volvox*, &c.  
 T. C. White, Esq. :—Vertical Section of Eye of Dragon-fly; Horizontal  
 Section of Human Scalp.  
 W. D. Wickes, Esq. :—Crystal of Sulphate of Copper and Magnesia;  
 Platinocyanide of Tetrium.

MEETING OF 18TH APRIL, 1894, AT 20 HANOVER SQUARE, W.  
 THE PRESIDENT (A. D. MICHAEL, ESQ., F.L.S.) IN THE CHAIR.

The Minutes of the Meeting of 21st March last were read and confirmed, and were signed by the President.

The List of Donations (exclusive of exchanges and reprints) received since the last meeting was submitted, and the thanks of the Society were given to the donors.

From

- S. H. Gage, The Microscope and Microscopical Methods. (5th  
 edition, 8vo, Ithaca, N.Y., 1894) .. .. . The Author.  
 Two Photomicrographs of young Fat Cells from foetal Cat .. .. Dr. W. C. Borden

Prof. F. Jeffrey Bell called attention to the copy of the 5th edition of Prof. Gage's work 'On the Microscope and Microscopic Methods,' which would be found to be a distinct advance upon previous editions. It would be seen that the author had in this edition largely availed himself of Dr. Dallinger's work, which had been published since the last issue. The present book could be well recommended as likely to be useful to students; it was illustrated by 153 figures.

Dr. W. H. Dallinger said that a stereoscopic photomicrograph had been sent for exhibition by Dr. W. C. Borden, the object being a specimen of *Helicopelta*. It might possibly have its advantages, but he was not yet quite able to see what these were. It was a photo-slide on which were two photomicrographs, but the stereoscopic result was not very apparent. The result, however, might be judged by the Fellows who would have the stereoscope and the photograph passed round to them.

Dr. Dallinger also said that at the last meeting of the Society he read a letter\* from Dr. H. G. Piffard in reference to a method which he had adopted for the examination of some of the old immersion objectives, and that he had found that one of them by Powell and Lealand had an angle as a water-immersion of  $143^\circ$ , which was equal to a numerical aperture of 1.26, and that this same objective worked well with cedar oil and gave N.A. of 1.44. More recently he had found that this objective would correct perfectly with monobromide of naphthaline. His next investigation showed that this objective of  $143^\circ$  with the

\* See this Journal, p. 286.



systems half closed gave  $144^\circ$ , and when quite closed also  $144^\circ$ , equal to a numerical aperture of 1.56 in monobromide of naphthaline, this being the highest yet obtained with a lens of that character. In looking over the work which Dr. Piffard had done he was himself unable to find any advantage over the results obtained by the use of monochromatic light. If they remembered that by its use a numerical aperture 1.40 was converted into one of 1.75, they would see what an immense advantage was to be obtained by employing it where a wide angle was desired. The Fellows of the Society would no doubt be glad to read Dr. Piffard's paper, and to test practically what results the use of monobromide gave.

---

The President said those present were no doubt aware that their recent *Conversazione* had proved a great success. It was attended by 378 Fellows and visitors, a number largely in excess of anything previously recorded on any similar occasion. The calibre of the exhibits and the mode of showing them was also a distinct advance upon what had hitherto been usual. He thought their thanks were due to the Committee, and especially to Mr. Dadswell, to whose exertions these successful results were largely due.

---

Mr. J. W. Brown exhibited a Microscope and its accessories, the history of which was of considerable personal interest. He described how, while a boy, his interest in the Microscope had been aroused at school in France, and how it had been strengthened whilst being further educated in Birmingham under the care of the present Cardinal Newman. Subsequently, on being placed in a business establishment at Brighton, he one day discovered a second-hand French Microscope for sale in a pawnbroker's window, and his desire to become the possessor of it led him to pay frequent visits of inspection. Having attracted the attention of the pawnbroker, he was questioned as to the object of his interest, and having explained what it was he came to gaze at, he was allowed to make a closer acquaintance with the instrument, and it was agreed that he should be permitted to call and use it and should be its owner on completion of the payment by instalments of the sum asked—25s. Eventually on his payments reaching 20s. it was handed over to him, and he began to work with it. Since that time he had made and added numerous accessories to it, and though as amateur work it was probably open to much criticism, he had been able to do a great deal of interesting work with it and hoped still to do more.

The President thought that Mr. Brown was not the only one in the room who had made his own Microscope, but he thought all would agree with him that any one who had sufficient persistence and enthusiasm to do as Mr. Brown had done was a person of the class that they wanted in the ranks of science. It had been a matter of frequent remark that many distinguished observers had worked with very rough instruments, and that very excellent work had been done with those which were even more primitive than the one before them. What Mr. Brown had told them that evening was another instance of how much could be done by persistence under difficult circumstances.

---



Prof. Bell said they would no doubt remember Mr. C. J. Pound, one of the Fellows of the Society, who used to be a regular attendant at their meetings. He was brought up in the Physiological Laboratory at King's College, whence he was taken by Dr. Crookshank to assist him in the new Bacteriological Laboratory. Mr. Pound some time ago went out to Australia to take up an appointment there, and had written a letter from which it appeared that he had been recently appointed Government Bacteriologist and Director of the Stock Institute in Queensland. Mr. Pound writes: "The Institute, which will be the first of its kind in Australasia, is intended for the study of diseases in live stock. It will possess both bacteriological and pathological laboratories, fully equipped with Microscopes, microtomes, and all the latest improved necessary apparatus for carrying on original investigations into the nature and causes of animal diseases, some of which, it is needless to say, are more or less peculiar to this colony. Another laboratory will be fitted with specially designed incubators and apparatus for the purpose of preparing and cultivating the attenuated vaccines of anthrax, symptomatic anthrax, tetanus, pleuro-pneumonia, &c. Adjoining the laboratories there will be a photographic department, furnished with a series of cameras for taking photographs of animals and morbid specimens; also a complete plant of apparatus for obtaining photomicrographs. In connection with the laboratories there will be a museum, specially devoted to the collection and preservation of specimens illustrative of the various manifestations of diseases in stock; also a collection of normal dissections and skeletons of comparative anatomy. As the colony of Queensland does not possess a Microscopical Society, the establishment of this institution will afford an admirable opportunity for those interested to take up the study and use of the Microscope, and in order to facilitate matters in this direction it has been recommended that classes be formed and arrangements made to deliver courses of lectures on microscopy and other subjects connected with the work of the Institute. From the geographical situation of Queensland, with its extraordinary climate and remarkable fauna and flora, it will at once be seen that there is a wide field and ample scope for prosecuting original research in any particular branch of biological science. It is therefore naturally expected that valuable results will be obtained from the investigations and special work which are to be carried on at the Stock Institute, thus affording much necessary information to the stock-breeders and pastoralists throughout the colony."

The President, in moving the thanks of the Society to Mr. Pound for his very interesting communication, expressed a hope that this would not be the last they should hear of the Stock Institute, which seemed happily founded in a district where there was a wide field of usefulness open to its investigations.

---

Mr. J. G. Grenfell read a paper "On the Tracks, Threads, and Films of Oscillatoria and Diatoms," the subject being illustrated by diagrams and by specimens shown under the Microscope in the room.

Mr. T. Comber said it was a little difficult to make observations on the things described by Mr. Grenfell, because the point raised was quite a new one; he thought, however, that they must be composed of some

substance such as had long been known to surround diatoms in the living state—mucus, gelatinous, “sticky stuff” would be good names to apply to it. Sometimes it surrounded the diatom as a sort of sheath, enabling it to be observed by staining; sometimes it consolidated itself at one end, forming a sort of stalk; sometimes it formed a film under the water, in which the diatoms were massed in large quantities; and sometimes it was consolidated into a tube, inside which the diatoms existed and could be seen moving up and down. These conditions were all known, but he had not seen it noticed that it formed things like those which Mr. Grenfell had described. He thought, however, that it was very probable that what Mr. Grenfell had seen was the earliest stage of what they were all well acquainted with; if so, the observation was a new one. But as to the nature of these things, he could offer no opinion at all.

The President said the subject was somewhat a novel one, and, therefore, it was not likely that any one would be prepared to say much about it without some further investigation. It was quite out of his own department, but it struck him that if a diatom really made the sheath of mucus in such quantity as to leave a train behind it, they ought to be able to see by microscopic examination of the organism that something was breaking down in order to give place and passage to it, and, as it must have come from somewhere, if it was produced in such a quantity it ought also to be possible to see the cells which were broken down in order to give rise to so large a quantity. It seemed, therefore, to him that microscopic examination should offer a promise of some chance of determining whether it was mucus streaming behind, or whether it was something of a different nature. He hoped that Mr. Grenfell would be able to make further investigations on the subject.

The thanks of the Meeting were voted to Mr. Grenfell for his paper.

---

The following Instruments, Objects, &c., were exhibited:—

Mr. J. W. Brown:—A Home-made Microscope.

Mr. J. G. Grenfell:—Diatoms in a network of threads, *Oscillatoria* with long trails, Pellets and network formed of indigo and threads by Diatoms in 48 hours, and Diagrams illustrating his paper.

Mr. C. F. Rousselet:—*Epistylis plicatilis*, mounted.

The Society:—A Stereoscopic Photomicrograph of *Heliopelta*, and Photomicrographs of young Fat Cells from foetal Cat, presented by Dr. W. C. Borden.

---

New Fellows:—The following were elected *Ordinary* Fellows:—Dr. Albert Abrams, Dr. Cuthbert Bowen, Mr. Edwin Charles Lacey, and Mr. Frederick Gwilym Treharne.

MEETING OF MAY 16TH, 1894, AT 20 HANOVER SQUARE, W.  
THE PRESIDENT (A. D. MICHAEL, ESQ., F.L.S.) IN THE CHAIR.

The Minutes of the Meeting of 18th April last were read and confirmed, and were signed by the President.

Prof. F. Jeffrey Bell said it was a most unusual occurrence for them to be without any list of Donations to announce, but on that occasion—whether from the hardness of the times or from other causes he could not say—not a single person had made a donation to the Society during the preceding month.

Mr. C. L. Curties exhibited and described a Microscope which had been specially made for photographic purposes, a feature of which was that the nose-piece was removable so that an ordinary short focus photographic lens could be substituted for the objective if required. He also exhibited a new form of apparatus for obtaining instantaneous photographs of objects under the Microscope, which he thought would be found of value where it was desired to obtain photomicrographs of living objects. The box, which formed the body of this camera, was fitted with a shutter carrying a right-angled prism, by means of which the object could be observed so as to determine when it was in the best position, the focus and amount of illumination being ascertained by previously examining an object requiring the same power as the living specimen. As examples of what could be done with this apparatus he showed two photomicrographs of blood-corpuscles taken with powers of  $\times 300$  and  $\times 600$  diameters, and also some low-power pictures of living specimens of *Lophopus* with tentacles extended. In taking these photographs Zeiss's apochromatic lenses had been used. He thought it would at least be seen from the specimens shown that it was quite possible to take instantaneous photographs of objects under the Microscope.

Dr. W. H. Dallinger thought that these photomicrographs were really very good, and was sure the Society would regard the successful manner in which they had been taken as a matter of great interest, especially as it had previously been thought to be hardly possible for such a thing to be done. He noticed in the immediate neighbourhood of the *Lophopus* there were some *Vorticellæ*, and this suggested that it might be possible to take them in the act of closing, so as to get an idea of how the movement was performed.

The President said that he was not himself in the habit of taking photographs, but he thought the Microscope exhibited was a very practical and handy instrument, supplying two or three wants felt by those who practised this kind of photography. The apparatus for taking instantaneous photographs under the Microscope was a thing they had not been in the habit of seeing. It would no doubt be of great service to many because these rapidly moving objects were most difficult to draw in what were really their natural positions. If, therefore, by this means only a good outline could be obtained, the details could be afterwards filled in by hand, and much more natural drawings might be thus obtained than were at present possible.

The thanks of the Society were voted to Mr. Curties for his communication.

Mr. W. H. Shrubsole said he had brought to the meeting a few living specimens of *Gromia*, and as now shown under one of the Microscopes upon the table the pseudopodia were to be seen all extended, rendering it a very interesting object. One peculiarity to be noticed was that instead of there being but one aperture there was a zone of small apertures round a central aperture, which he thought was a good reason why this object should be removed from the *Monostomia*. Another object he exhibited was a naked Rhizopod closely allied to *Lieberkuhnia*, and answering the description of it so nearly that the only difference appeared to be that the one had an investing envelope of something, and the other had not. It was known that *Gromia* had the power of throwing off its outer coating, in fact, when first taken the whole of the forms would be found with their investing coatings, but after a few days the naked forms would appear, and it was, he thought, very likely that *Gromia* could become *Lieberkuhnia* by thus throwing off its outer robe. A third object, which he was showing, consisted of some Foraminifera belonging to the *Reticulosa*, which might be described as "linear-tubular" with slightly tapering ends, and with a single aperture at either end, so that it was very beautiful to see the pseudopodia extended from both ends and to see the currents produced by them. They were not very easy to examine, because they would not separate themselves from the mud, and when shaken up they would generally fix themselves to the glass very firmly by the two ends pulling against each other. In principle this organism resembled *Shepherdella*, but it was not exactly like it. In recently looking into the 'Challenger' reports he found a form called *Astrorhiza granulosa*, the description of which might apply to nearly every form he was showing. Though alike in appearance the difference between them in one respect was great, the one being found in the mud in the salt marshes, whilst the other came from deep water of not less than 1000 fathoms.

The *Gromia* had a remarkable faculty for collecting dirt particles about it, so that very often small patches of mud might be seen with cilia proceeding from the ends. And these tenacious things could hold on to and kill infusoria much larger and higher in the scale of life than themselves. He had also on the previous day obtained from the water off Sheerness some masses of a dirty looking substance containing all sorts of forms of gelatinous objects in which were imbedded a number of granules. He had first called attention to these some years ago in 'Nature,' and had since tried without success to develop them. They were the cause of what the fishermen called "foul water" or "May water"; they were only seen at certain seasons and for a short time, and it would be an interesting inquiry to find out what became of them.

Prof. Bell felt sure when Mr. Shrubsole called upon him a short time ago, that he would be able to interest the Society with an account of what he had been observing. Mr. Shrubsole was well known to many of those present on account of his investigations of the organisms found at the mouth of the Thames, but he believed this was the first time he had come amongst them with a communication of this kind, and he hoped that it would not be the last, but that he would be able to continue the study of these organisms, and that at some future time they



might hear something more about them. Mr. Shrubsole mentioned that he had not been able to gain any information from any naturalist upon the subject of foul water; this of course pointed to the desirability for pursuing the inquiries. He had just been present at the annual inspection of the Marine Biological Laboratory at Plymouth, and he found that one of the greatest troubles there had been the condition of the water. Only two fish had died during the last year, and these were flat fish that did not appear to be able to feed themselves—in this respect the aquarium could not be said to have suffered much, but there were appearances which made the Director desirous of obtaining information as to the Diatomaceous and Desmidaceous condition of the water in the tanks. Very little was at present known of marine bacteria, and the first thing they wanted to determine, was whether the water was better or worse for containing the bacteria. Other inquiries naturally suggesting themselves would be, what the organisms really were, which caused this “foul water.” Was the foul water due to their presence? were they a great number of larvæ undergoing transformation? In a Society like theirs, he thought they ought to be able to find means of determining such questions, and he would venture to suggest that some one should go down to Plymouth and make a minute study of the water there. He might remind the Fellows that when this marine station was established, their Society gave a donation of 100*l.* towards the funds, and that they were consequently entitled to nominate a worker at one table for one month in each year. Mr. Shrubsole had brought before them a number of facts of which he could give them no explanation, and what he had just mentioned tended to show that there were a great many other people who were in the same position with regard to this subject. Mr. Shrubsole must not think therefore that his want of success in obtaining information was due to his own ignorance, rather than to the ignorance of mankind at large.

The President was sure all who had heard Mr. Shrubsole’s statement, must have done so with great pleasure. The subject was one to which he had devoted special attention, and one also which involved many points of special interest. One which occurred to him was whether the peripheral coat of protoplasm was always permanently in one condition, or whether its differentiation might be a condition of the animal at one particular period of its existence. This was a matter which had not been very well worked out, and it was only by working it out that their knowledge on a subject of the highest interest could be advanced. They would therefore all hope that Mr. Shrubsole would be able to continue his investigations and would be in this way able to assist at least some portion of the way towards its elucidation.

The thanks of the Society were, on the motion of the President, unanimously voted to Mr. Shrubsole for his communication.

Mr. Shrubsole said he was greatly obliged to the Fellows present for the way in which his communication had been received. He should like to supplement what he had said by mentioning that the fishermen found it useless to attempt to carry on their fishing operations whilst the water was foul, so that it seemed evident that whatever the organisms were, they were distasteful to fish. He might perhaps be allowed to correct one remark made by Prof. Bell, as to his not having been a

contributor to the Society's Proceedings before, as on one occasion, at King's College, he had read a paper on the Diatoms of the London Clay.

Prof. Bell called attention to three frames placed upon the table in the room, containing the photomicrographs forming the Society's exhibit at the Chicago Exhibition; the Fellows would have now the opportunity of seeing them, and determining whether they were worthy of the medal which they were told had been awarded them. Having read to the meeting the letter from the Society of Arts communicating the official announcement of the award, he said they would keep this carefully as a proof of their deserts.

The President was quite sure that those who had not had a previous opportunity of examining these photographs would be very glad to do so now; they arrived so late that there was only just time to send them with the other things forwarded by the Society of Arts, and the present was therefore the first opportunity of showing them in that room. He thought they would be found well worthy of inspection; the careful way in which Mr. Nelson had mounted his contribution would no doubt be noticed.

Prof. Bell thought that the Fellows of the Society would be glad to hear that Mr. Nelson appeared to be improving in health; he had been very ill indeed, but had now so far recovered as to be able to go into the country, and reported himself as "beginning to pick up again."

The President said they were much obliged to Prof. Bell for the interesting remarks made as to his recent visit to Plymouth. He did not know whether it was owing to the Whitsun holidays, or to the summer coming on, that there was no formal paper to bring before the Society that evening.

The following Instruments, Objects, &c., were exhibited:—

Mr. C. L. Curties:—A new form of Microscope; Instantaneous Apparatus for use in Photomicrography.

Mr. R. Macer:—*Pedalion*.

Mr. C. F. Rousselet:—Mounted Rotifers.

Mr. W. H. Shrubsole:—*Gromia*, *Lieberkuhnia*, *Shepherdella*, and other organisms from Sheerness.

The Society:—Photomicrographs from the Chicago Exhibiton.

New Fellows:—The following was elected an *Ordinary* Fellow:—  
Rev. W. Arthur Bird.

AUG 24 1894

JOURNAL  
OF THE  
ROYAL MICROSCOPICAL SOCIETY.

AUGUST 1894.

---

TRANSACTIONS OF THE SOCIETY.

---

VII.—*The Foraminifera of the Gault of Folkestone.*—VI.

By FREDERICK CHAPMAN, F.R.M.S.

(Read 20th June, 1894.)

PLATE VIII.

*Sub-family NODOSARIINÆ—continued.*

VAGINULINA d'Orbigny [1826].

THE group of the *Vaginulinæ* from the Gault formation is an important one, since it bears characters distinct from those found in the Jurassic and other deposits. It is, moreover, an exceedingly difficult genus to deal with, as the specimens present few distinguishing points which will serve to separate them into specific or varietal forms. The *Vaginulinæ* of the French Gault formation have been very carefully worked out by M. Berthelin, who gives in his admirable and comprehensive monograph 'Sur les Foraminifères fossiles de l'étage Albien de Montcey'\* a system of classification which embraces some

---

EXPLANATION OF PLATE VIII.

- Fig. 1.—*Vaginulina recta* Reuss. *a*, side view; *b*, back edge view. × 45.  
,, 2.—*V. recta* var. *tenuistriata* var. nov. × 45.  
,, 3.—*V. strigillata* Reuss sp., typical form. *a*, side view; *b*, back edge view.  
× 35.  
,, 4.—*V. strigillata* Reuss sp., slender variety. × 35.  
,, 5.—*V. truncata* Reuss. *a*, side view; *b*, back edge view. × 45.  
,, 6.—*V. truncata* Reuss. × 45.  
,, 7.—*V. truncata* Reuss var. *robusta* Berthelin and Chapman. *a*, side view;  
*b*, back edge view. × 45.  
,, 8.—*V. gaultina* Berthelin. *a*, side view; *b*, back edge view. × 45.  
,, 9.—*V. arguta* Reuss. *a*, side view; *b*, back edge view. × 45.  
,, 10.—*V. striolata* Reuss. × 45.  
,, 11.—*V. comitina* Berthelin. × 45.  
,, 12.—*V. sparsicostata* Reuss. *a*, side view; *b*, back edge view. × 60.  
,, 13.—*V. discors* F. Koch. × 45.  
,, 14.—*V. Biochei* Berthelin. *a*, side view; *b*, front edge view. × 45.  
,, 15.—*V. Priceana* sp. nov. *a*, side view; *b*, front edge view. × 60.

---

\* Mém. Soc. géol. France, 1880, sér. 3, vol. i. No. 5.

of their more constant characteristics.\* The intimate relations existing between the groups of the *Froniculariæ* and the *Vaginulinæ* are also discussed by the same author.

In the series of Foraminifera from Folkestone a number of monstrous specimens of *Vaginulinæ* occur, which are very interesting from a morphological standpoint; and the notes upon these aberrant forms I propose to introduce at the end of this series of papers.

*Vaginulina recta* Reuss (plate VIII. fig. 1 a, b).

*Vaginulina recta* Reuss, 1862, Sitzungsab. d. k. Ak. Wiss. Wien, vol. xlvi. p. 48, plate iii. figs. 14, 15. *V. recta* Berthelin, 1880, Mém. Soc. géol. France, sér. 3, vol. i. No. 5, p. 41, plate ii. figs. 5a-6b. *V. recta* Burrows, Sherborn and Bailey, 1890, Journ. Roy. Micr. Soc., p. 559, plate X. figs. 10-13.

This species is distinguished by the elongate and narrow form of the shell, and its more or less parallel edges; moreover the diameter of the initial spherical chamber is nearly equal to the width of the lateral aspect of the shell at its commencement. The surface of the primordial chamber is sometimes decorated with one, or more rarely two crescent-shaped costulae. The surfaces of the succeeding chambers are slightly convex.

*V. recta* was first described by von Reuss from beds equivalent to the Gault in North Germany, and it is also noted by that author from the Gault of Folkestone. It is also common in the Gault of Montcley (Berthelin), and mentioned as frequent from the Red Chalk of Speeton (Burrows, Sherborn and Bailey).

It is well distributed through the Gault formation at Folkestone, zone ii., spec. a, very rare; zone iii., frequent; zone iv., frequent; zone v., common; zone vi., very rare; zone vii., very rare; zone ix., rare; zone x., very common; zone xi., 55 ft. from the top, very common; 50 ft., very common; 45 ft., common; 40 ft., common; 35 ft., common; 30 ft., common; 25 ft., common; 20 ft., very rare; 12 ft., frequent; 6 ft., rare.

*Vaginulina recta* Reuss var. *tenuistriata* (plate VIII. fig. 2).

This variety resembles the specific form *V. recta* in having a rectilinear manner of growth, and a large and well-inflated initial chamber. The variety usually possesses a larger number of chambers, sometimes as many as fourteen. The surface of the shell is decorated with five vertical or oblique striae which are interrupted and very rarely appear to bridge over the sutural costae. The surface of the initial chamber is marked with striations, and is sometimes strongly costulate. It is distinguished from *V. paucistriata* Reuss,† by the absence of the four vertical ribs running down the back of the

\* Mem. Soc. géol. France, 1880, sér. 3, vol. i. No. 5.

† Sitzungsab. d. k. Ak. Wiss. Wien, 1862, vol. xlvi. p. 48, pl. iii. figs. 16 a-c.



shell, and two on the front or inner side, the edge views of *V. recta* var. *tenuistriata* being unornamented and slightly convex. Von Reuss' variety, moreover, has two strong costulae on the central area of each chamber. The length of the figured specimen measures 1/14 in.

It occurs at Folkestone in zone v., rare; zone vi., rare; zone vii., frequent; zone ix., rare; zone x., very common; zone xi., 50 ft. from the top, very rare; 35 ft., rare; 30 ft., very rare; 25 ft., very rare; 12 ft., frequent; 6 ft., rare.

*Vaginulina strigillata* Reuss sp. (plate VIII. figs. 3 a, b, and 4).

*Citharina strigillata* Reuss, Verstein. böhm. Kreidef., part ii., 1846, p. 106, plate xxiv. fig. 29.

The specimens from the Gault are easily recognized by the fine but sharp vertical striation of the shell-surface, the markings running uninterruptedly over the sutural lines of the chambers; the sutural costae being depressed in this species nearly to the general level of the surface of the shell. The initial chamber is more or less well inflated and sometimes elongated in the direction of the length of the shell. The edges of the test are strongly costate. The coarser varieties of this form may, perhaps, be comparable with the fragmentary specimen figured by von Reuss under the name of *V. angustissima*.\*

*V. strigillata* was described from the Plänermergel of Bohemia (Reuss); recorded from the Gault of Kent, probably Folkestone (Rupert Jones in Morris' Catalogue and the "Weald" Memoir); and I have since found it in the Chalk Marl of Folkestone and the "Chalk detritus" of Charing, Kent.

This species is found in the Gault of Folkestone in zone viii., very rare; zone x., very common.

*Vaginulina truncata* Reuss (plate VIII. figs. 5 a, b, and 6).

*Vaginulina truncata* Reuss, 1862, Sitzungsber. d. k. Ak. Wiss. Wien, vol. xlvi. p. 47, plate iii. fig. 9. *V. truncata* Berthelin, 1880, Mém. Soc. géol. France, sér. 3, vol. i. No. 5, p. 39, plate i. figs. 25-28.

The figure given by von Reuss under the above name is taken by M. Berthelin for the type of a series of *Vaginulina* which occur abundantly in the Gault of France and elsewhere, and though presenting great variation in the general outline of the shell, are distinguished by the presence of a smaller initial chamber as compared with that of *V. recta*, by the more or less flat surface of the chambers between the sutural costae, and by the absence of superficial ornamentation, with the exception of the initial chamber which is often decorated with lunar-shaped or branching costae. This latter

\* Sitzungsber. d. k. Ak. Wiss. Wien, 1862, vol. xlvi. p. 45, pl. iii. fig. 3.

characteristic is illustrated by M. Berthelin (loc. cit.) on plate i. figs. A-F. M. Berthelin also recognizes two varieties of *V. truncata*, one of which he terms "var. *délicate*" and the other "var. *robuste*." Both of these varieties are well represented in the series from Folkestone, and since the robust variety is fairly distinct from the delicate form (the latter being more like the figure given by Reuss), I propose to retain the thinner and neater variety as the type species, and to call the coarsely grown specimens *V. truncata* var. *robusta*. This separation of the two forms may be useful in studying their zonal distribution in the Gault. *V. truncata* is recorded from the Upper Hils formation and the Speeton clay of North Germany (Reuss); and from the Gault of Monteley (Berthelin). It also occurs not unfrequently in the Chalk-marl of Folkestone and the "Chalk detritus" of Charing.

The species *V. eurynota*, which was described by von Reuss from Folkestone,\* and which has subsequently been obtained from the Red Chalk of Speeton (Burrows, Sherborn and Bailey)† appears to be closely related to *V. truncata*, to which name I have relegated the Gault specimens which show a curvature in the line of growth; these varieties are however impossible to separate in a large series of specimens.

*V. truncata* is found in the Folkestone Gault in zone ii., specimen *b*, very rare; zone iii., frequent; zone iv., rare; zone v., rare; zone vi., rare; zone vii., rare; zone viii., rare; zone ix., frequent; zone x., very common; zone xi., 45 ft. from the top, rare; 40 ft., frequent; 20 ft., very rare; 12 ft., rare; 6 ft., frequent.

*Vaginulina truncata* Reuss var. *robusta* Berthelin and Chapman,  
plate VIII. fig. 7 *a*, *b*.

*Vaginulina truncata* (pars) Berthelin, 1880, Mém. Soc. géol. France, sér. 3, vol. i. No. 5, p. 40 ("var. *très-robuste*"), plate ii. fig. 4 *a* and *b*.

This variety differs from the type form of *V. truncata* in having a test of much thicker and coarser growth; the vertical costulate margins and the transverse sutural costæ being of thicker proportions than in the type form. The whole shell has a rough and ragged appearance, and the surfaces between the sutural ridges are in many cases deeply excavate. The edge view of the shell on the apertural side shows a surface sometimes curiously ornamented with short and twisted strigillations.

This variety was found in the Gault of France; at Folkestone it occurs in zone v., very rare; zone vii., common; zone viii., very rare; zone ix., rare; zone x., very common; zone xi., 55 ft. from the

\* Sitzungsab. d. k. Ak. Wiss. Wien, 1862, vol. xlvi. p. 90, pl. xii. fig. 9.

† Journ. Roy. Micr. Soc., 1890, p. 559, pl. x. fig. 9.

top, common; 50 ft., common; 45 ft., common; 40 ft., common; 35 ft., common; 30 ft., common; 25 ft., common; 20 ft., common; 12 ft., frequent; 6 ft., very rare.

*Vaginulina gaultina* Berthelin, plate VIII. fig. 8 a, b.

*Vaginulina gaultina* Berthelin, 1880, Mém. Soc. géol. France, sér. 3, vol. i. No. 5, p. 39, plate i. figs. 22 a-24.

This species has been described from the Gault of Montcley by M. Berthelin, and it is a characteristic fossil at Folkestone. I have also met with very good examples of *V. gaultina* from the "Chalk detritus" of Charing, Kent. In outline the shell is broader and more equi-triangular than *V. truncata*. It is easily distinguished by its strongly and obliquely striated sutural ridges. The initial chamber is inflated, and resembles that of *V. truncata* in point of size. The surfaces of the inter-sutural spaces are flat or slightly excavate.

*V. gaultina* is found in the Folkestone Gault, in zone iii., very rare; zone iv., very rare; zone v., rare; zone vii., frequent; zone viii., very rare; zone ix., rare; zone x., very common; zone xi., 55 ft. from the top, frequent; 35 ft., very rare; 30 ft., very rare; 25 ft., very rare.

*Vaginulina arguta* Reuss, plate VIII. fig. 9 a, b.

*Vaginulina arguta* Reuss, 1860, Sitzungs. d. k. Ak. Wiss. Wien, vol. xl. p. 202, plate viii. fig. 4. *V. arguta* Reuss, 1862, op. cit., vol. xlvi. p. 47, plate iii. fig. 13. *V. arguta* Berthelin, 1880, Mém. Soc. géol. France, sér. 3, vol. i. No. 5, p. 42, plate ii. figs. 7 a-8 b. *V. arguta* Burrows, Sherborn and Bailey, 1890, Journ. Roy. Micr. Soc., p. 559, plate x. figs. 14, 15.

The above name can be conveniently applied to those forms which do not possess a salient initial chamber, but which in other respects resemble *V. truncata*.

*V. arguta* is by no means a common form in the Gault series. It has previously been recorded from the Flammenmergel and the *Minimus*-thon of North Germany and the Gault of Folkestone (Reuss); from the Red Chalk of Speeton (Burrows, Sherborn and Bailey) and from the Gault of France (Berthelin).

It is found in the Gault of Folkestone in zone x., rare; zone xi., 55 ft. from the top, rare; 50 ft., very rare; 45 ft., rare; 25 ft., rare; 20 ft., rare; 12 ft., frequent; 6 ft., rare.

*Vaginulina striolata* Reuss, plate VIII. fig. 10.

*Vaginulina striolata* Reuss, 1862, Sitzungs. d. k. Ak. Wiss. Wien, vol. xlvi. p. 46, plate iii. fig. 7.

This species resembles *V. arguta* in respect of the non-salient initial chamber, but differs from it in having the surface of the shell

striated obliquely, somewhat like that of *V. gaultina*. *V. striolata* was recorded from the Flammenmergel of North Germany by von Reuss.

One specimen only was found in zone x. of the Gault at Folkestone.

*Vaginulina comitina* Berthelin, plate VIII. fig. 11.

*Vaginulina comitina* Berthelin, 1880, Mém. Soc. géol. France, sér. 3, vol. i. No. 5, p. 38, plate i. fig. 21 a-d.

Some of the *Vaginulinæ* with striate costæ from the Gault, on careful observation are seen to possess an initial chamber which is not exactly in line with the rest of the shell, that is not terminal, but placed towards the inner side of the usually incurved commencement; the specimens showing this variation from the characters found in *V. gaultina* have been named *V. comitina* by M. Berthelin. The initial chamber is also smaller in this form, and, though more or less salient, is deeply set, and therefore scarcely seen when the edge view is taken. The costal ridges are not so conspicuously striate as in *V. gaultina*.

Besides occurring in the Gault, *V. comitina* is found in the "Chalk detritus" of Charing; and some of the specimens I have met with from the latter material are exceedingly beautiful and extreme varieties of the species.

It is found in the Gault at Folkestone in zone x., frequent; zone xi., 40 ft. from the top, very rare; 30 ft., very rare; 25 ft., very rare; 12 ft., rare; 6 ft., rare.

*Vaginulina sparsicostata* Reuss, plate VIII. fig. 12 a, b.

*Vaginulina sparsicostata* Reuss, 1862, Sitzungsab. d. k. Ak. Wiss. Wien, vol. xlvi. p. 50, pl. iv. fig. 4.

A fragmentary specimen was found in the Gault of Folkestone which is clearly referable to the above species. *V. sparsicostata* belongs to the series of triangular *Vaginulinæ*, with obscure segmentation and vertical or radial strigillate markings on the surface of the shell; the initial portion of the shell is distinctly pointed.

The above species is recorded by von Reuss from the Upper Hils-ton of N. Germany, and the same species is noted in the author's MS. as associated with the Foraminifera from the Neocomian (Lower Greensand) beds of Guildford, in Surrey.

The only specimen found at Folkestone was from zone v. of the Gault.

*Vaginulina discors* F. Koch, plate VIII. fig. 13.

*Vaginulina discors* F. Koch, 1848, Palæontographica, vol. i. p. 172, plate xxiv. figs. 1, 2. *V. discors* Reuss, 1862, Sitzungsab. d. k. Ak. Wiss. Wien, vol. xlvi. p. 50, plate iii. figs. 10-12.



This beautiful and variable form is rare in the Gault. It is strongly suggestive of an arrested or uni-laterally developed variety of *Frondicularia Karreri* or *F. strigillata*.

*V. discors* is recorded from beds of Neocomian age (Speeton Clay) in N. Germany. It occurs in the Gault at Folkestone in zone vii., very rare; zone xi., 6 ft. from the top, very rare.

*Vaginulina Biochei* Berthelin, plate VIII. fig. 14 *a, b*.

*Vaginulina Biochei* Berthelin, 1880, Mém. Soc. géol. France, sér. 3, vol. i. No. 5, p. 42, plate ii. fig. 9 *a, b*.

This elegant little species is apparently peculiar to the Gault formation; and, moreover, it is very rarely met with there, two specimens only occurring in an extremely large assemblage of *Vaginulinæ* obtained from the Folkestone Gault-clay. It is also rare in the Gault of France.

*V. Biochei* was found at Folkestone in zone i., specimen *b*, very rare; zone xi., 6 ft. from the top, very rare.

*Vaginulina Priceana*, plate VIII. fig. 15 *a, b*.

Shell sub-oval, produced at the oral extremity, and well rounded at the commencement. The sides are flat, and the margin rounded. Chambers numerous, eleven in the specimen found; the first chamber oval, as in *V. Biochei* (to which species this form bears some general resemblance), the rest narrow and recurved. The sutures of the chambers in the later growth of the shell are marked by a thickening or ridging of the shell, and this filleting extends beyond the general outline at the aboral end, appearing as blunt prickles. The first half of the shell is obliquely and sinuously striated, but the sutures of the 8th, 9th, and 10th chambers are regularly decorated with short oblique strigillæ; the margin of the last chamber is relieved by a sharp and interrupted ridge running more or less paralld with the edge of the shell. The aperture is situated just under the extremity of the last chamber, and consists of a simple but slightly elongated orifice. Length of shell,  $1/35$  in.; greatest breadth,  $1/66$  in.

I have much pleasure in naming this species after Mr. F. G. Hilton Price, F.G.S., to whom students of Cretaceous geology are indebted for his valuable work towards defining the various zones of the Cretaceous strata, and especially of the Gault.

*V. Priceana* was found at Folkestone in zone xi., 45 ft. from the top, very rare.

---

VIII.—*On the Unreliability of certain Characters, generally accepted for Specific Diagnosis in the Diatomaceæ.*

By THOMAS COMBER, F.R.M.S., F.L.S.

(Read 20th June, 1894.)

WHEN the systematic study of diatoms was first taken up, those engaged in it, being mostly concerned with the discrimination of the various forms which they met with, naturally adopted, for their diagnostic characters, such features as were the most readily perceptible. Amongst these, there were none more easy of recognition, and of description, than those regarding number and size; and accordingly we find, in the works of Ehrenberg and Kützing, many specific characters based upon these.

Any differences in the number, whether of the elevations on the dorsal margins of the valves of *Eunotia* and *Himantidium*; of the rays or radial segments of those of *Actinocyclus*, *Actinoptychus*, *Asterolampra*, and other discoid genera; of the processes in *Eupodiscus* and *Aulacodiscus*; or of the constrictions in *Biddulphia* and *Eunotogramma*; were alike regarded as justifying the formation of so many distinct species.

As an instance of the extent to which this was carried, may be cited Ehrenberg's species quoted by Ralfs as synonyms of his *Actinocyclus Ehrenbergii*. They are 119 in number, and all based upon the varying number of the rays, from *A. ternarius* with three rays to *A. Panhelion* with 120.

Nor was a difference in number regarded as constituting a character of only specific value, for, according to the number of angles which a valve might have, it was referred to the different genera *Triceratium*, *Amphitetras*, or *Amphipentas*; although such valves may now be regarded as not even specifically distinct. Ehrenberg also proposed the genera *Tripodiscus*, *Tetrapodiscus*, and *Pentapodiscus*, for what is now seen to be a single species, *Aulacodiscus Argus* A. Schmidt, according to the number of processes. Yet this may be different in the two valves of the same frustule.

Prof. W. Smith, in his 'Synopsis of the British Diatomaceæ,' followed the older observers in using such characters for the separation of species, but with some doubt, for he remarks regarding *Actinoptychus duodenarius*, *A. sedenarius*, and *A. octodenarius* Ehrenberg, that the "three forms are probably the same species in different stages." He even goes so far as to refuse to recognize as distinct species *Biddulphia tri-ocularis*, *B. quinque-ocularis*, and *B. septem-ocularis* Kützing, and refers them all to *B. pulchella* Gray.

A few years later, Ralfs, in Pritchard's 'Infusoria,' rejected such characters, explaining that he considered species founded on them as "altogether unscientific and erroneous." He therefore constituted

*Actinocyclus Ehrenbergii*, *Eunotia Ehrenbergii*, and *E. robusta*, to include many forms, varying in this respect, previously regarded as distinct species; and his action has been generally approved by subsequent authors.

Forms differing in size alone, or with only a slight difference in the fineness of the striation, such as *Navicula rhomboides*, *N. crassinervia*, and *Frustulia saxonica*, are now generally regarded as not constituting distinct species. They are, however, still considered by some to form distinct varieties, as the names of the numerous varieties denominated by Prof. Grunow as "maxima," "major," "media," "parva," "minor," "minima," "minuta," and "minutissima," sufficiently indicate. It is probable, however, that these are, for the most part, mere stages of growth, especially as the formation of megafrustules, by a process more or less resembling conjugation, has now been observed in so many species, that the increase of size thus attained may be regarded as a normal phase in the life-history of the organisms. It would, consequently, be as reasonable to describe an oak sapling and a full grown oak tree as distinct varieties, worthy of distinguishing names.

This now generally admitted insufficiency of two of the principal characters formerly relied on as a sufficient distinction of species, renders it desirable to inquire how far dependence can be placed upon other characters, even yet usually accepted as of specific importance.

The first to be noticed may be the very slight differences in the outline of the valve, such as are portrayed in plate vii. of Prof. Van Heurck's 'Synopsis des Diatomées Belges,' illustrating § Radiosæ of *Navicula*. When we consider that forms having valves triangular, square, pentagonal, and hexagonal, which would formerly have been referred to several different genera, are by most observers now included in a single species of *Triceratium* or *Stictodiscus*, it is plainly questionable whether the very slight differences of shape, which some of Prof. Van Heurck's figures show, can be reasonably held to constitute separate species. Prof. Gregory was the first to appreciate the variability of outline in diatoms. As far back as 1855 he wrote:—"The more that the Diatomaceæ are studied the more do we perceive that in many species the shape or outline is subject to endless variations." He therefore proposed two comprehensive species, *Pinnularia varians* and *P. mutabilis*, each to include several reputed species of previous authors. The step was in advance of the day, and Gregory's species have not been generally adopted. But his view was correct, and the yet more extended knowledge of the present day proves that, although species formerly considered distinct are met with in many gatherings, each retaining its own character, and without any intermediate forms, in other gatherings they occur with every gradation of form, constituting a perfect and unbroken transition from one to the other. Under these circumstances it seems to me undesirable to retain between them the distinction of "species." Instances of an undue

multiplication of species on similar grounds occur in the groups containing *Pinnularia nobilis*, *P. major*, and *P. viridis*; in § Asymmetrica of *Gomphonema*; and in forms allied to *Navicula aspera*, to *N. liber*, to *N. firma*, to *Rhaphoneis amphiceros*, and to *Triceratium Favus*.

The character upon which Prof. Smith chiefly relied, regarding it as "sufficiently constant to form a safe guide" to the determination of species, was striation, and especially the relative fineness or coarseness of the striæ. In this belief he maintained that "striation is the best guide." A more extended examination of forms from different localities has, however, shown that the supposed constancy of this character does not exist. The range of variation, so gradual that each step is almost imperceptible, is, on the contrary, very great. Striation is, in fact, only another term for cellulation, which in one form or other is observable in almost all diatom valves; and although the relative fineness or coarseness of the cellulation of discoid forms is a character still frequently made use of for specific distinction, it is in reality one of extreme variability. Of this any one may be convinced by examining any gathering which contains in abundance such a form as *Cocconodiscus concinnus* variety *Jonesianus*. Valves will be found with the cellules three times as fine as those on other valves, with a complete series connecting the two. In other species, as for example *Cocconodiscus elegans*, *Cestodiscus pulchellus*, and *Melosira granulata*, the two valves of the same frustule not unfrequently differ greatly in the size of their cellules. In *Denticula* the costæ on the two valves of the same frustule, and in *Pinnularia* even those on the two sides of the same valve, occasionally differ considerably from each other. In *Cocconeis* the different striation of the upper and lower valve is now well known; but before it had been fully recognized, it sometimes led to the two valves being placed in different genera. Thus *Mastogloia maxima* Grunow is nothing but the lower valve of a form of the common and extremely variable *Cocconeis scutellum*. In view of the magnitude of these differences in valves, which can be shown to belong to the same species, distinctive characters based upon comparatively very slight differences in the spacing of striation, in other words of the cellulation, are clearly inadmissible.

Not only does the spacing of the striation vary, but occasionally its character also. When a frustule is in course of subdividing, the appearance of the striation on the two newly formed inner valves is sometimes entirely different to that on the two older outer valves. The difference obviously arises from the valves being in different stages of development; yet, if the older and younger valves were observed apart from each other, they would probably be regarded as distinct species, and might even be referred to quite different sections of the genus.

A character dependent upon the so-called striation, which is equally subject to variation, is the position and extent of the blank



spaces. In Raphidieæ, they may lie on either side of the raphe; or transversely to the valve, forming a pseudo-stauros; or midway between the raphe and the margin. In discoid forms they may be either central or radial. All are more or less inconstant; yet numerous species have been proposed for extremely slight variations; and in *Navicula* two of the main sections of the genus, adopted by Prof. Grunow, the "Lyratæ" and the "Hennedyæ," have been based upon them, although even the two typical species, *N. lyra* and *N. Hennedyi*, are themselves connected by a series of intermediate forms.

The arrangement of the striæ in the megafrustule of a species, in some cases differs from that in the ordinary form. A slide, for which I am indebted to the late Mr. Haughton Gill, shows the megafrustule of a species of *Amphora*, with a large central blank. It therein differs so materially from the parent frustules, that it would certainly be regarded as a distinct species, had not its formation by their union been observed. The cultivation of diatoms, as originally suggested by Dr. Miquel of Paris, has probably much to teach us in this respect.

The distinction formerly relied on, as separating the two genera *Eupodiscus* and *Aulacodiscus*, was the presence or absence of radial blanks between the processes and the centre of the valve; but more complete observation has shown that this feature is quite unreliable, and consequently Mr. Rattray, in his monograph of *Aulacodiscus*, includes in that genus even the original typical species of *Eupodiscus*, such as the old *E. Argus* and *E. Rogersii*.

A character used for specific diagnosis, chiefly in the Cryptoraphidieæ, which is also very variable, is the relief of the valve. The valve may be flat, or more or less convex, or with an elevation or depression in the centre; and on such characters numerous species have been formed; yet the two valves of a frustule may differ completely in this respect; or the terminal valves of a filament differ considerably from the others. A notable instance occurs in *Triceratium Montereyi* Brightwell, described as differing from *T. arcticum* in the centre of the valve being elevated in a very peculiar manner; but the front view of a frustule sometimes shows that one valve is quite flat, the other quite conical, in fact, in the same gathering, specimens of these forms and of *Biddulphia balæna*, which is only another form of the same species, may be found, some with both valves flat, some with one valve flat and the other convex, and some with both valves convex.

There only remains to notice one more character too variable to be at all relied on, namely, the presence or absence of spines or apiculi, whether marginal or variously placed on the surface of the valve. The species of *Stephanopyxis* and *Systephania* were mostly distinguished from each other by differences in these appendages; but there can be little doubt that several of them should be united. By such a character, too, Ehrenberg distinguished his genus *Odontodiscus*, now

abandoned. *Coscinodiscus* (*Odontodiscus*) *excentricus* is a good example, for it exhibits a complete gradation from the entire absence of teeth, to a thick-set coronet.

The natural result of the adoption, for specific diagnosis, of such characters as have been mentioned above, has been the undue multiplication of specific names, and the overburdening of diatom nomenclature with an enormous mass of synonyms. Apart from the too frequent description of altogether identical forms by different authors, under different names, specific designations have been given to forms differing from each other only in characters which are quite inconstant. Some observers justify the practice, maintaining that it is convenient to have distinctive names for forms, however unimportant the points in which they differ from each other, without entering into the question as to what constitutes a "species."

Fortunately, that is a question into which it is quite unnecessary for us to enter. All that we have to consider, in connection with our present subject, is the much simpler one, what does *not* constitute a species. The two valves of an oyster differ considerably from each other, but none would suggest that they belong to two species, or that it is desirable to give them different specific names. The plumage of a young bird is sometimes very unlike that of the adult form; but it is not, on that ground, to be regarded as a distinct species. In like manner, neither the two valves of a diatom, nor the stages of growth through which it passes, however unlike they may appear, should be so regarded: and, however convenient it may be to give distinctive names to each slight variation in diatoms, I venture to maintain that the practice is unscientific.

No true conception of the limits of a species in diatoms can be formed until the complete life-history of these organisms has been, at any rate in some instances, traced out; and this has yet to be accomplished. Meanwhile it will be better to refrain from designating as "species," not only forms which, by actual observation, are known to appertain to an already established species, but also forms which, from what we know of other species, may be reasonably believed to belong to or spring from established species.

---

SUMMARY OF CURRENT RESEARCHES  
RELATING TO  
ZOOLOGY AND BOTANY  
(PRINCIPALLY INVERTEBRATA AND CRYPTOGAMIA),  
MICROSCOPY, ETC.

*Including Original Communications from Fellows and Others.\**

ZOOLOGY.

A. VERTEBRATA:—Embryology, Histology, and General.

a. Embryology.†

Von Baer's Law and the Significance of Ancestral Rudiments in Embryonic Development.‡—Mr. A. Sedgwick recognizes that von Baer's law, that embryos of different members of the same group are more alike than the adults, and that the resemblances are the greater, the younger the embryos, is generally regarded as one of the fundamental postulates of zoological science. He sets himself to show that this view is not in accordance with the facts of development, and first takes the case of the fowl and the dog-fish; he cites the chief points of difference between them, and sums up the comparison by saying that a blind man could distinguish between them. It is, of course, freely admitted that there are striking similarities between them, but it is questioned whether the differences, when set off against them, leave sufficient to justify Baer's law. That law should, therefore, be replaced by the following: "Embryos of different members of the same group often resemble one another in points in which the adults differ, and differ from one another in points in which the adults resemble; and it is difficult, even if possible, to say whether the differences or the resemblances have the greater zoological value, since we have no clearly defined standard of zoological value."

Again, if von Baer's law have any meaning at all, animals so closely allied as the fowl and duck would be indistinguishable in the early stages of development; yet the author says he can distinguish a fowl

\* The Society are not intended to be denoted by the editorial "we," and they do not hold themselves responsible for the views of the authors of the papers noted, nor for any claim to novelty or otherwise made by them. The object of this part of the Journal is to present a summary of the papers *as actually published*, and to describe and illustrate Instruments, Apparatus, &c., which are either new or have not been previously described in this country.

† This section includes not only papers relating to Embryology properly so called, but also those dealing with Evolution, Development and Reproduction, and allied subjects.

‡ Quart. Journ. Micr. Sci., xxxvi. (1894) pp. 35-52.

from a duck embryo on the second day by the inspection of a single transverse section through the trunk; *Peripatus capensis* and *P. Balfouri* are so alike when adult, that if it had not been for their embryonic differences, Mr. Sedgwick would not have instituted the second species. Indeed, it may be concluded that a species is distinctly distinguishable from its allies from the very earliest stages all through the development, although the embryonic differences do not necessarily implicate the same organs as do the adult differences.

With regard to the significance of ancestral rudiments in embryonic development, Mr. Sedgwick points out that the assumption that the repetition of ancestral characters in embryogeny is the intelligible rule is not warranted by the fact that in the vast majority of ontogenies there are no phylogenetic traces, nor by the consideration that a number of important organs, such as teeth in birds, limbs in snakes, gill-clefts in fishes, have recently disappeared without leaving a trace in ontogeny.

The balance of evidence appears to Mr. Sedgwick to point most clearly to the fact that the tendency in embryonic development is to directness and abbreviation, and to the omission of ancestral stages of structure. The fact that some organs are represented by vestiges, while others leave no trace, is perhaps to be explained by the differences between the embryonic and the larval modes of development; modes which have generally not been properly distinguished by naturalists who have written on the subject.

In embryos the organs are for the most part functionless, and without relation to the maintenance of life, so that there is nothing to counteract the tendency to the appearance of a variation at all stages in the life of an organ. In larvæ, on the other hand, the organs are functional, and if a variation of an organ at one stage is injurious to the same organ at a previous or a subsequent stage, it will be eliminated at the stages at which it is injurious.

The conclusion to which the author arrives is that, whereas larval development must retain traces of ancestral stages of structure, because they are built out of ancestral stages, embryonic development need not necessarily do so, and very often does not; embryonic development, in so far as it is a record at all, is a record of structural features of previous larval stages.

Mr. Sedgwick points out that the principles which he sets forth explain why it is that in higher animals it is the early stages of development which have the greatest interest for us, the later stages having been added at a time when, as now, the immature stages of free life were but little marked, and consequently there was but little chance of the incorporation of any ancestral features in the embryonic development. They help us, further, to understand why the most interesting of the ancestral embryonic features were related to the passage from the aquatic to the terrestrial condition, because when this took place in phylogeny there must have been a most pronounced aquatic larval stage such as we find to-day in Amphibia.

**Effect of External Conditions on Development.\*** — The pith of Prof. A. Weismann's Romanes lecture appears to lie in the doctrine that even when "to all appearance external influences have had direct action in causing purposeful modifications, a more careful examination will

\* Nature, 1. (1894) p. 31.



always show that they have only served to bring some preformed adaptation into activity."

**Yolk-nuclei in Meroblastic Ova.\***—Prof. H. E. Ziegler discusses these bodies as illustrations of nuclear degeneration. He believes still, as he did some years ago, that they are elements left behind in the development of the embryo. In *Torpedo* he is quite convinced that from the beginning of gastrulation the "meganuclei" take no part in the formation of the germinal layers. He discusses some of the interpretations of the yolk-nuclei, all of which, his own included, leave one with the impression that not very much is certainly known about them.

**Fertilization of Trout's Ovum.†**—Prof. H. Blanc finds that the formative "germ" is present in the ovum before submergence and that fertilization has nothing to do with its appearance. The germinal vesicle does not disappear towards the end of maturation; a polar spindle is formed while the ovum is still in the abdominal cavity; the first polar body is expelled immediately after laying. In contact with the water the contents of the egg (germ and vitellus) exhibit certain movements which alter the position of the nucleus in relation to the micropyle. Fertilization occurs half a minute after mixing the elements, polyspermy is exceptional, but not pathological. The second polar spindle gives rise to the second polar body and to the attractive sphere of the female pronucleus. Maturation is only completed when the two nuclei have each their attractive sphere. Unfertilized eggs form two polar bodies; the process is quite independent of fertilization. The pronuclei come together 9–10 hours after fertilization; the attractive spheres fuse; the nuclear membranes disappear; the segmentation nucleus is formed. The first cleavage is in a plane perpendicular to the equatorial plane in which the segmentation spindle lies. Thus Prof. Blanc has confirmed in regard to trout some of the general results of recent studies of fertilization.

**Development of the Teeth in the Adder.‡**—Dr. C. Röse describes the origin of the dental ridge and the appearance of the tooth-germs. As in other Reptilian embryos, there are on the premaxilla *two* germs of "egg-teeth." The same bone bears rudimentary germs of other teeth. Ten rudiments of fangs were observed. As to the structure of the teeth, Tomes was right in maintaining the presence of a thin layer of enamel; it extends from the cap downwards as far as the tooth projects from the mucus-membrane. As in Crocodylians and Chamæleons, there is a transitory enamel-pulp with stellate cells; it lies in the poison canal and disappears. The origin of the various layers of the tooth are carefully described.

**Development of Excretory System in Amphiuma.§**—Mr. H. H. Field finds that the rudiment of the mesonephros in *Amphiuma* is strictly metameric, as in Cæcilians. There is a subsequent irregular duplication of the nephrostomes and nephrostomial canals in the anterior segments of the kidney. The *canalis principalis* remains undivided, while the *canalis nephrostomialis* is doubled.

\* Ber. Nat. Ges. Freiburg, viii. (1894) pp. 192–209 (4 figs.).

† Tom. cit., pp. 163–91 (1 pl., 1 fig.).

‡ Anat. Anzeig., ix. (1894) pp. 439–51 (10 figs.).

§ Comptes Rendus, cxviii. (1894) pp. 1221–4.

In other Urodela the pronephros consists, with two exceptions, of only two canals, each with a single nephrostome. In *Amphiuma* the pronephros is in relation with three primitive segments. There is but one true pronephric canal for each segment. Field's observations led him to decide against regarding the pronephros as a definite ancestral organ distinct from the mesonephros.

In *Ielthyophis*, which has a pronephros related to 12 or 13 segments, the pronephros and the mesonephros are in contact, or even superposed. The pronephros of the other Batrachians which have been studied is followed by an interval of 2-4 segments without an excretory canal, before one reaches the mesonephros. In *Amphiuma* the interval extends to 22 segments.

**Development of the Thymus.\***—Mr. J. Beard has had an opportunity of studying this in an extensive series of embryos of *Raia batis*. There seems to be little doubt that the organ is, in the main, hypoblastic in nature, and Mr. Beard has evidence that the thymus is actually a portion of the lining of each gill-cleft, but there are no thymus-elements in connection with the spiracle or the mouth, though the author inclines to the view that the vesicular follicle of the spiracle and of the angle of the mouth are rudimentary equivalents of such elements.

It has been found that the ordinary teaching that the cell-elements of the thymus retain their epithelial characters after their proliferation is completed, is incorrect; the original cells of the thymus are somewhat rounded bodies possessing more the characters of lymph or adenoid cells than of epithelium.

The migration of lymph-cells into the thymus is generally accepted, Kölliker alone having given a true account of the facts; he showed that the thymus cells become at first arranged in epithelial fashion, forming glandular-like tubes; in *Raia* and other fishes the similar cells, immediately on their birth from the parent epithelium, take on the lymphoid characters which are only later acquired by Mammals. All Mr. Beard has seen leads him to deny the migration of lymph-cells into the thymus at any period; he considers that the lymph-elements of the thymus are the direct offspring of the epithelial cells of a gill-cleft. In other words, a leucocyte-forming structure arises from the hypoblastic epithelium of gill-clefts.

This formation of leucocytes in the immediate neighbourhood of the gills must be for the protection of the gills themselves; it is suggested that they may serve to devour and remove parts of the gills which have undergone necrosis, while their importance as guards against microbes need not be dilated on. To Mr. Beard the thymus in its function bears some resemblance to the tonsils, which, in the higher Mammals, where respiration is on a different type, usurp their duties.

**Haacke's Theory of Gemmaria.†**—Prof. R. von Lendenfeld summarizes and criticizes this theory, recently elaborated by Dr. W. Haacke.‡ The plasma of the egg-cell or any cell consists of the smallest organized

\* Anat. Anzeig., ix. (1894) pp. 476-86.

† Biol. Centralbl., xiv. (1894) pp. 413-6.

‡ 'Die Schöpfung der Thierwelt,' Leipzig, 1893; 'Gestaltung und Vererbung,' Leipzig, 1893.

particles or gemmæ, built up of gemmæ, which in turn consist of albuminoid molecules. Moreover, the gemmæ are rhombic prisms, and arranged in columnar bundles—the gemmæria! As the gemmæ change in arrangement, the gemmæria change in shape, and the whole animal varies. Fertilization strengthens the system of gemmæria, and enables the offspring to ward off injurious influences more readily. “Haacke clears away the ruins of older theories and the weeds of Weismannism which have sprung from among them,” and bases on this Gemmæria-theory his doctrine of evolution. This is an old acquaintance—Lamarckianism. “The facts proving the inheritance of acquired characters are as abundant as the sand on the shore,” but the critic regrets that not a grain is in evidence. The system of gemmæria is in internal equilibrium, and, like a wave, an external influence spreads through the soma to the germ-cells. Von Lendenfeld has something to praise, however, namely, Haacke’s arguments in favour of Northern Eurasia being the cradle of the higher terrestrial races. There is also some well-done expository work in the ‘Schöpfung der Thierwelt.’

#### β. Histology.

**Microscopic Foam and Protoplasm.\***—Attention is called to Mr. E. A. Minchin’s translation of Prof. Bütschli’s work on this subject, which has more than once been referred to in this Journal or at the Society’s Meetings. The writer ventures to express scepticism as to the correctness of Bütschli’s view, urging that we ought not to conclude that the causes of movement in protoplasm are the same as those in artificial foam. It is pointed out that Bunge, who may be taken as an example of the new school of vitalists, argues with much force that vital manifestations cannot at present be explained by any known physical or chemical forces. A perusal of this author’s lectures on physiological chemistry is recommended as a corrective to Bütschli’s theories. Although the latter has succeeded better than his predecessors in making something like protoplasm, the experiments of Rainey, Harting, and Ord, are not to be forgotten—still less those of Montgomery, who (in 1867) obtained movements in a kind of artificial protoplasm by mixing myelin with water, and obtained forms which simulated varicose nerve-fibres, the broken-down matter of brain and spinal cords, and even cells. To the work of his non-German predecessors Prof. Bütschli makes no reference.

**Relations of Isotropous to Anisotropous Layers in Striped Muscles.†**—Mr. H. M. Bernard arrives at the following “provisional conclusions.” The isotropous layers retreat into the anisotropous; this retraction is alone sufficient to account for muscle contraction; and there is a certain amount of evidence to show that the anisotropous layer is a mass of nuclear substance.

#### γ. General.

**Zoological Regions.‡**—Mr. A. R. Wallace urges that zoological regions, to be at once natural and useful in the highest degree, must be founded on a combination of essential features:—

\* Brit. Med. Journal, No. 1741 (1894) p. 1027.

† Zool. JB. (Anat. Abth.) vii. (1894) pp. 533-44 (1 pl.).

‡ Nature, xlix (1894) pp. 610-3.

(1) They should be founded on and approximate to the great primary geographical divisions of the earth, as these seem to have been permanent during considerable geological periods.

(2) They should be rich and varied in all the main types of animal life.

(3) They should possess great individuality, either by the possession of numerous peculiar forms, or the entire absence of forms which are abundant and widespread in adjacent regions.

Mr. Wallace thinks that the Scattered regions seem all that can be desired. As there is such difference of opinion as to the subdivisions of the primary regions he suggests that, for the present, no attempt should be made to name definite subdivisions. All proposed regions are, from some points of view, natural, but the whole question of their grouping and nomenclature is one of convenience and of utility in relation to the object aimed at.

**Autotomy in the Animal Kingdom.\***—M. L. Fredericq, who has devoted much attention to this subject, has a general essay on it, in which there are many interesting observations. He concludes that autotomy was at first a voluntary and intentional movement, due to an instinct of self-preservation. This movement was gradually perfected and adapted more perfectly to the end in view; simultaneously it lost its intentional character and became a purely reflex action.

**Zoology of Irish Sea.†**—Prof. Herdman was appointed chairman of a Committee of the British Association to report on this subject. It is pointed out that the region round the Isle of Man, made classical by the investigations of Edward Forbes, is interesting from the considerable diversity of shore, of depth, and of bottom, and it possesses an abundant fauna, which includes a number of rare and novel forms. The members of the committee have collected and identified about 1000 species of marine animals, of which 38 are new to the British fauna, 224 to the district, and 17 to science.

**Chemistry of Organisms.‡**—Dr. A. Frebault has gathered together a number of more or less well-known facts in regard to the chemical composition and changes characteristic of organisms. He shows how scientific conceptions have been changed by modern advances in physiological chemistry, without however himself appreciating some of these. He makes a point of illustrating the unity of animal and plant life, suggesting that the biologists have not yet assimilated Claude Bernard's lessons.

**Phylogeny of Chordata.§**—Mr. W. Garstang has a preliminary note on a new theory of the phylogeny of the Chordata. It postulates a common ancestor for the Echinoderma, Enteropneusta and Chordata; this was bilaterally symmetrical and had the external appearance of a young *Auricularia* larva; at the apical pole were a pair of pigmented ciliated pits, resembling the eye-spots of *Tornaria*; this pelagic ancestor had at least two pairs of bilaterally symmetrical enterocoelae, of which

\* Bull. Acad. Roy. Belg., lxiii. (1893) pp. 738-72.

† Rep. Brit. Ass., 1893 (1894) pp. 526-36 (1 map).

‡ Mem. Acad. Sci. Toulouse, v. (1893) pp. 277-322.

§ Zool. Anzeig., xvii. (1894) pp. 122-5.



the first pair communicated by water-pores with the exterior; the central nervous system consisted of an elongated nerve-ring which lay exactly underneath the circumoral ciliated ring.

The Echinoderma were derived from this hypothetical ancestor by a series of changes mainly correlated with the secondary assumption of a radial symmetry; the right anterior enterocœle atrophied, and the nerve-ring became separated from the circumoral ciliated band.

In Chordata the circumoral ciliated ridges of the two sides approximated dorsally and fused along their entire length in the mid-dorsal line, and constituted a canal which was ciliated internally, and communicated with the gut by means of the blastopore (neurenteric canal). The præoral pigmented pits represent the optic vesicles of Vertebrate embryos. The number of enterocœles became greatly increased with the evolution of the Chordate type.

The Enteropneusta are to be derived from the hypothetical Auricularian ancestor by a rather more complicated series of changes; the ciliated bands fused only in the middle region of the body, which eventually became the collar region of the adult; this limitation of the area of fusion explains the curious fact that the præ-oral sense-organs are not enclosed in a medullary tube as they are in Vertebrates, but remain on the external surface of the body, and also that there is no neurenteric canal in *Balanoglossus*, where the blastopore persists as the anus. It is probable that an adoral ciliated band, comparable to that of *Auricularia*, persists in some form of *Tornaria*; Mr. Ritter's recent discovery of a ventral ciliated (?) tract suggests to Mr. Garstang that Mr. Ritter has very probably come across the desired homologue of this adoral band.

## B. INVERTEBRATA.

Deep-sea Invertebrates of Indian Ocean.\*—Dr. A. Alcock reports on a small but interesting collection; *Cerianthus* and *Cyathohelia* are for the first time reported from the Bay of Bengal. *Dipsacaster* (*D. pentagonalis* sp. n.) is a new genus of Astropectinidæ, *Astroschema flosculus* is a new species from the lately discovered coral bank north of Madras; *Echinolampas*, though known as a Sind fossil, has not till now been found living in the Bay of Bengal; interesting Mollusca and Crustacea were also found.

Dimorphism due to Parasitism.†—Prof. A. Giard points out that the variations of crabs and the like, which require double "curves of Galton" to express them, may be, and in some cases seem demonstrably due to the dimorphism which the presence of parasites produces. Biological statistics alone, as elaborated by Bateson and Weldon, are insufficient to solve the problem; a minute examination of each case is necessary. Besides parasitism, other ethological factors may determine multiple states of biological equilibrium on which segregation and selection operate. In the case of dimorphism due to parasitism, the condition of the infested forms is generally, to use his new term, pædomorphic.

\* Journ. Asiatic Soc. Bengal, lxii. (1894) pp. 169-77 (1 pl.).

† Comptes Rendus, cxviii. (1894) pp. 870-3.

**Winter Fauna of the Upper Rhine.\***—Herr R. Lauterborn has studied the pools and water-basins of the Upper Rhine. He gives lists of the Protozoa and Rotifers, and notes that some Protozoa and all the species of *Notholca* predominate in winter. Among Flagellata, *Bicosæca socialis* sp. n., *Sphærocæca Volvox* g. et sp. n., *Mesostigma viride* g. et sp. n., *Gymnodinium tenuissimum* sp. n., *Holophrya nigricans* sp. n., *Disematosoma Bütschli* g. et sp. n., and *Bursaridium Schewiakowii* g. et sp. n. are briefly described.

#### Mollusca.

**Histology of Mid-gut Gland.†**—Prof. J. Frenzel discusses the minute structure of the mid-gut gland (liver) of no less than 64 Lamellibranchs and Gastropods. His previous researches (1886) led to the conclusion that this variable gland was a pancreas but not a hepato-pancreas. The present paper contains histological contributions which the author believes to be necessary before any further conclusions are risked. One misses, however, amid the long array of individual results, any general summary, which a promised continuation will probably supply.

#### γ. Gastropoda.

**Nerves of Oculiferous Tentacle of *Helix pomatia*.‡**—Dr. P. Samassa has been able to distinguish the following parts; central processes of sensory cells which branch in an arborescent manner; fibres of unknown origin arising from the lower part of the ganglion and having branched endings which form a plexus with the sensory branches; thirdly, there are fibres which arise from the tentacular nerve, divide into two branches in the upper part of the ganglion, and send their branches into the processes; in the lower part of the ganglion there are coiled fibres with lateral branches; there are other fibres which send out a branch towards the layer of ganglion-cells, which is probably the process of a ganglionic cell; and, lastly, there are ganglion-cells with one or several processes, which are generally branched. The tentacular ganglion probably differs in structure from the brain only in the want of motor elements; it is a sensitive part of the central nervous system, and the tentacular nerve is to be considered as a connective.

***Hydrobia ulvæ*.§**—Dr. H. Henking describes the structure of this Gastropod, and the way in which the eggs are protected within small clumps of agglutinated sand. For although no positive proof was forthcoming that the egg-clumps were those of *Hydrobia*, they were found on the majority of the shells dredged, as well as on many different kinds of animals living in the same locality. The ciliated larvæ were observed. Of the anatomy, hitherto but imperfectly described, a full account is given.

**Circulatory and Renal Organs of Chitons.||**—Dr. L. Plate has been so fortunate as to obtain, on the coast of Iquique, some Chitons as much

\* Biol. Centralbl., xiv. (1894) pp. 390-8.

† Verh. K. Leop.-Carol. Akad. Halle, lx. (1894) pp. 321-408 (4 pls.).

‡ Zool. JB. (Anat. Abth.), vii. (1894) pp. 592-608 (2 pls.).

§ Ber. Nat. Ges. Freiburg, viii. (1894) pp. 89-110 (1 pl.).

|| SB. Akad. Wiss. Berlin, 1893, pp. 962-6.

as 10 cm. long, with which he has made observations on the circulatory and renal organs; in all, four species have been studied.

The structure of the heart is the same in all, but differs in many points from the description given by Bela Haller; each auricle pours its blood into the ventricle by two openings, an anterior which is clearly identical with that seen by Haller, and by a posterior one which is some distance from the hinder end of the ventricle. With regard to the supply of vessels from the aorta to the gonad, there is a constant difference in the two sexes; in the male, there are given off from the ventral side of the aorta numerous delicate vessels, which pass into the lumen of the testis, and are arranged in two rows; in the female, the ovarian vessels are arranged in one row, and are stronger. A good many details are given; the author finds there is no direct connection between the aorta and the pedal vessels; the venous blood does not collect in the cœlom, and pass thence by a transverse lacuna into the branchial artery, but is collected in the deepest part of the body, the foot, and passes thence directly by means of the pedal sinus to the branchial artery.

Sedgwick's account of the structure of the kidney is preferred to that of Haller, as he correctly distinguished the efferent duct from the renopericardial canal. Both, however, overlooked a considerable part of the organ; there are in the foot two delicate canals which run parallel to the median blood-sinus; these the author calls the median renal ducts in contrast to the already known lateral ducts; they give off a large number of small, arborescent lateral branches, some of which project freely into the cœlom. There are also other canals in the foot given off from the renal sacs, the presence of which has been altogether overlooked.

The renopericardiac duct varies in length somewhat in the different species, and there are also differences in the size of the renal sac.

#### δ. Lamellibranchiata.

**Sense of Light in Eyeless Bivalves.\***—Dr. W. A. Nagel notes that many eyeless bivalves have a very keen sense of light. The critical experiment implies observing that the animal moves on being suddenly shaded or illumined. Animals may be "skioptic," or "photoptic," or "photoskioptic," without being "ikonoptic." Graber's wider term "photodermatic" includes all the reactions due to the influence of light on skin sense-organs.

Nagel's experiments show that *Ostrea edulis*, *Cardium oblongum*, and *Venus gallina* are almost exclusively skioptic; *Cardium tuberculatum*, *C. aculeatum*, *Venus verrucosa*, *Cytherea chione*, *Macra stultorum* vary from being skioptic to being also photoskioptic; *Pholas dactylus*, *Lithodomus dactylus*, *Macra helvacea*, *Tellina complanata* are photoskioptic; *Tellina nitida*, *Solen siliqua* and *S. ensis*, *Tapes (Venus) decussata* vary from being photoptic to being photoskioptic; *Lima hians*, *Psammobia vespertina*, and *Capsa fragilis* are photoptic; *Solecortus strigillatus*, *Loripes lacteus*, and *Cardita sulcata* are not sensitive to either light or shade, but perhaps the slight opening of the shell should be more considered.

\* Biol. Centralbl., xiv. (1894) pp. 385-90.

Circulatory System of *Dreissensia polymorpha*.\*—M. Toureng notes that this form, divergent from the Mytilidæ as regards its nervous system, is remarkable in its circulatory arrangements. Thus, there is a large posterior aorta, and the rectum occupies its cavity. A cross section shows the doubly contoured blood-vessel surrounding the gut, and its structure suggests that it arises from the confluence of two vessels. At the anterior third of the adductor, the posterior aorta gives off two pallial arteries, each of which divides into a dorsal and a ventral branch. The ventral branches unite with the anterior pallial arteries to form the circum-pallial vessels. Pericardial, rectal, gastro-intestinal, visceropodal, and hepatic arteries are also described.

### Molluscoida.

#### a. Tunicata.

So-called Segmentation of the Tail in Appendicularia.†—Dr. O. Seeliger finds in *Fritillaria furcata* and *Oikopleura cophocerca* that each of the seven so-called "muscle-segments" is a large muscle-cell. The contractile substance forms parallel lamellæ of fibrils on the side of the cells towards the chorda, and extending continuously along the whole length of the tail. Moreover, it is to be noted that the ganglia do not correspond in number nor in distribution with the segments, and are variable.

Degeneration of *Distaplia*.‡—M. Caullery has studied a degenerative process affecting colonies of *Distaplia rosea* D. V., and confirms some results recently published by Salensky. But he does not seem to believe in Salensky's "symphagocytes," nor in the return of liberated cells to the tunic and nutritive stolons, there to be transformed into mesenchyme. The dominant phenomenon of the whole degenerative process is phagocytosis.

Caullery also notes that the testa-cells arise by mitosis from follicular cells and not by a budding of the germinal vesicle; that the cells of the testa do not contribute to the formation of the tunic; that the peribranchial cavity of the oozoite is formed entirely from two ectodermic invaginations; that the tail of *D. rosea* degenerates as Kowalewsky described in *Phallusia*; that the colonies of *D. magnilarva* are unisexual, for one of the sexual organs of the hermaphrodite bud degenerates finally at an early date.

#### β. Bryozoa.

Bryozoa of Hungary.§—Dr. E. Vángel finds that about two-thirds of the European Bryozoa occur in Hungary, though only two species have been hitherto recorded. His preliminary list takes notice of ten species.

### Arthropoda.

Derivation and Homologies of some Articulates.||—Prof. J. D. Dana prefers the term Articulates to Arthropods, as he considers that Crustacea

\* Comptes Rendus, cxviii. (1894) pp. 929-30.

† Zool. Anzeig., xvii. (1894) pp. 162-5.

‡ Comptes Rendus, cxviii. (1894) pp. 598-600.

§ Zool. Anzeig., xvii. (1894) pp. 153-5.

|| Amer. Journ. Sci., xlvii. (1894) pp. 325-9; reprinted in Ann. and Mag. Nat. Hist., xiii. (1894) pp. 502-6.



and Insects are less closely related to one another than Annelids and Insects. He thinks there is reason for believing that Annelids, Crustaceans, and probably Limuloids, were derived independently from the Rotifera. The Nauplius-larva shows that the Crustacean type is not successional to a many-jointed Annelid, but rather to some Pedalion-like Rotifer.

The diversities and agreements of Limuloids from and with Crustaceans suggest a derivation nearly like that of the Crustacean type, but probably not from Crustaceans.

A line of succession from Worms to Myriopods and from Myriopods to Insects has not been proved by geological discovery, but is suggested by *Peripatus* and by certain resemblances between Annelids and Myriopods; Scudder has pointed out the resemblance of the Carboniferous *Paleocampa* to the caterpillar of *Arctia*.

In both Insects and Spiders the rise of grade involved a general concentration of the structure towards the cephalic nervous centre. The fact that as higher Insects rise in grade the larval stage becomes lower and lower in embryonic level suggests that the larval stage results from an attendant retrograde embryonic change to a line parallel with the Myriopod, and beyond to the memberless condition of a worm. If we accept the view that, as many zoologists hold, the two pairs of maxillæ of Insects belong to a single body-segment, we find that the thorax and head of an Insect are essentially homologous with the head of a tetradecapodous Crustacean.

#### a. Insecta.

**Insect Sight and the Defining Power of Composite Eyes.\***—Mr. A. Mallock is led by his observations and calculations to conclude that Insects do not see well, at any rate as regards their power of defining distant objects, and their behaviour favours this view. They have, however, an advantage over simple-eyed animals in the fact that there is hardly any practical limit to the nearness of the objects they can examine. With the composite eye the closer the object the better the sight, for the greater will be the number of lenses employed to produce the impression; in the simple eye, on the other other hand, the focal length of the lens limits the distance at which a distinct view can be obtained. Of the various forms of Insects examined, the best eye would give a picture about as good as if executed in rather coarse wool-work, and viewed at a distance of a foot.

**Phylogeny of the Pierinæ.†**—We must be content with calling attention to Dr. F. A. Dixey's paper on this subject; he confines himself to the evidence afforded by wing-markings and by geographical distribution. The subject is treated with great detail, but is intelligible only to the professed student of the group in the present state of the investigation.

**Notes on Micro-Lepidoptera.‡**—Dr. T. A. Chapman deals with such forms as have larvæ that are external feeders, and expresses his belief that the Zygenidæ, Limacodidæ and Eriocephalidæ form a group which

\* Proc. Roy. Soc. Lond., lv. (1894) pp. 85-90 (3 figs.).

† Trans. Entomol. Soc. Lond., 1894, pp. 249-334 (3 pls.).

‡ Tom. cit., pp. 335-50 (2 pls.).

has been evolved, on its own lines, from a common source, as a separate branch of the Heterocera. Particular attention is given to the early stages of *Eriocephala cathella*.

**Seasonal Dimorphism and Polymorphism in Japanese Butterflies.\***—Dr. A. Fritze describes these phenomena in *Papilio machaon*, *P. xuthus*, *Pieris napi*, *Colias hyale*, *Terias biformis*, *T. multiformis*, *Thecla arata*, *Polyommatus phlaeas*, *Vanessa levana*, *V. burejana*, and *V. c. aureum*. He refers the extraordinary frequency of the phenomena to the peculiar climatic and physical conditions of the Japanese islands. The ends of the chain exhibit Arctic and tropical conditions; and even within narrow range very diverse climates are combined. The winter of central Japan is not very different from that of South Germany, though the snow melts almost at once, but the summer is much hotter. Thus the winter generations are very like, the summer generations very different in these two widely separated countries. The variety of climate within narrow range may account for the great variability of many Japanese butterflies. It seems that, in general, higher temperature is associated with darker pigmentation of the scales.

**Bees and Dead Carcasses.†**—Mr. W. F. Kirby directs attention to an article by Baron C. R. Osten Sacken ‡ on the production of Bees from the carcasses of dead oxen, in which it is pointed out that the original cause of this mistaken belief is to be found in the fact that the common drone-fly (*Eristalis tenax*), which does lay its eggs on carcasses, has in shape, hairy clothing, and colour, a remarkable resemblance to Bees. The wasps said to be bred from horses are really examples of *Helophilus*, a genus of Diptera allied to *Eristalis*. From Mr. Kirby's extracts it is clear that the Baron's article is well worth reading in its entirety.

**Glandular System of Ants.§**—M. C. Janet has chiefly studied the glands of *Myrmica rubra*, but other ants examined show no essential differences from it. All the salivary glands which he describes are formed of very large cells, each of which has a large nucleus and a small excretory canal. The cells may be isolated, when they are spherical or pyriform, or they may be packed more closely and have plane surfaces of contact, or they may, lastly, be fused into more or less large masses. The gland situated at the base of the antennæ of Hymenoptera has not, so far as the author knows, been seen by any author. The mandibular gland is extremely well developed in Ants, its excretory ducts are grouped in bundles and abut on a perforated plate situated on the inner side of a large reservoir with very delicate walls; this reservoir varies in volume, and the variations are partly effected at the expense of the large tracheal trunk which passes near it.

After giving details as to some other glands, the author states that he has till now failed to discover groups belonging morphologically to the thoracic segments, but he has found two enormous groups of glandular cells which ought to be regarded as belonging to the first post-thoracic

\* Ber. Nat. Ges. Freiburg, viii. (1894) pp. 152-62.

† Nature, xlix. (1894) pp. 555 and 6.

‡ Boll. Soc. Entomol. Ital., xxv. (1893).

§ Comptes Rendus, cxviii. (1894) pp. 989-92.

segment; he is inclined to think that the products have the function of charging with odours the air in a tegumentary chamber which is connected with these glands. Near the abdominal stigmata and near the anus there are groups of small glandular cells.

**Poison-Apparatus of Hymenoptera.\***—M. Bordas has found both the alkaline gland (gland of Dufour) and the acid gland in a hundred species, not only among Aculeata, but among Ichneumonidæ, Tenthredinæ, &c. It may be safely said to be of general occurrence. The acid gland consists of three parts, the glandular portion, the reservoir for the poison, and the excretory canal. The alkaline gland is an irregular tube, with a striated surface and without a reservoir. In most Hymenoptera there is yet a third gland—unpaired, granular, rectangular or lanceolate—with a short filamentous duct which opens beside the orifice of the alkaline gland.

**Salivary Glands of Ichneumonidæ.†**—M. Bordas has also a preliminary notice of his work on the salivary glands of these Hymenoptera, of which he recognizes six sets—the thoracic, the supracerebral, the mandibular, the sublingual, the lingual, and the maxillary; the last are so reduced as to be almost atrophied.

**Defensive Ejection of Blood.‡**—M. L. Cuénot finds that Leydig was right (1859) in asserting that certain Coleoptera ejected their blood in self-defence. He has proved this in *Timarcha tenebricosa* Fabr., *T. coriaria* Fabr., and *Adimonia tanaceti* Fabr., among the Chrysomelidæ; in *Coccinella septempunctata* L. and *C. bipunctata* L., among the Coccinellidæ; in *Meloe proscarabeus* L., *M. majalis* L., and *M. autumnalis* Oliv., among the vesicating insects. When the insect “feigns death,” drops of blood are squeezed through the cuticle; its repulsive qualities are known chemically and have been proved experimentally.

**Alimentary Canal of Orthoptera.§**—Sig. O. Visart describes the minute structure of various Orthoptera. The fore-gut shows external longitudinal muscles, a zone of transversal or annular muscles, internal longitudinal muscles, a chitinogenous matrix, and a chitinous intima. The mid-gut has longitudinal and annular muscles, a sub-epithelial connective membrane or tunica propria, and the glandular epithelium with four types of cells, whose distribution, secretory activity, chromatolysis, and gemmation are minutely described. In connection with the hind-gut special attention is given to the “pore-canals.”

**Flight of Locusts.||**—Mr. C. B. Mitford gives an interesting account of what was, he says, a more marvellous sight than he has ever seen. The changed appearance of the “bush” at Freetown, Sierra Leone, on the 25th November, 1893, led him to call the attention of a native, who told him that locusts were coming. In a short time huge black clouds appeared above the hills, and those first seen gave the idea that the whole of the sides of the hills, three miles off, were on fire; at 2.45 p.m. these

\* Comptes Rendus, cxviii. (1894) pp. 873-4.

† Zool. Anzeig., xvii. (1894) pp. 131-3.

‡ Comptes Rendus, cxviii. (1894) pp. 875-7.

§ Atti Soc. Tosc. Sci. Nat., xiii. (1894) pp. 20-54 (34 figs.).

|| Proc. Zool. Soc. Lond., 1894, p. 2.

supposed clouds reached Freetown and proved to be a continuous mass of locusts, which passed without intermission till 5.10 p.m. Myriads settled but made no apparent difference in the size of the swarms. The whole town was covered with their excrement. At 9.45 a.m. the next day the stream began again, but not in such dense masses, and continued up to 1 p.m. The species has been found to be *Pachytylus migratoroides*, originally described from Abyssinia.

**Dipterous Parasites of Locusts.\***—M. J. Künckel d'Herculais notes a number of cases now known in which Bombyliidæ are parasitic in the eggs of Acridiidae, and not as usual in the larvæ of Hymenoptera. He has himself studied the Bombylid larvæ found in the ova of *Stauronotus maroccanus*. The larvæ emerges from the egg in August, reaches the limit of its growth in October, passes the winter in "hypnodic" within the egg-case, and is hatched the following summer. The hypnodic state may be prolonged for as many as three winters. The metamorphosis is divided into two stages; in the first the nymph is active, in the second very inactive; the usually continuous phenomena of histolysis, associated with metamorphosis, are here interrupted by an interval of several days.

He † finds that *Stauronotus maroccanus*, *Acridium ægyptium*, and other Acridiidae are followed on their devastating march by various viviparous Diptera, e. g. *Sarcophaga atropos*, Meigen, *S. cruentata* Meigen, *S. nurus* Rondani, which deposit their larvæ in the bodies of the locusts. The parasitism of these larvæ results in a sort of rachitic condition; the fatty body is devoured, the wing-muscles are enfeebled, the gonads atrophy. In short, parasitic castration and "aptenia" result, for which the Diptera deserve acknowledgment.

**Tracheal System of Locusta.‡**—Dr. V. Nietsch notes the rarity of precise figures or descriptions of the tracheal system of insects. He figures and describes that of *Locusta viridissima*. There are ten stigmata. The 1st leads to five branches, two dorsal, two ventral, and a very strong one to the tibia of the first leg, where the auditory organ lies; the 2nd has two branches, to second leg and anterior wing; the 3rd has four branches, a ventral, two dorsals, and one to the third leg; the 4th has five, two ventral, two dorsals, and a visceral; the 5th and 6th have four, a ventral, two dorsals, and a visceral; the 8th–9th have five branches, a ventral, two dorsals, a branch to the intestine, and one to the reproductive organs; the 10th has three branches, two dorsally, and a ventral which gives off three viscerals.

**Tertiary Tipulidæ.§**—Mr. S. H. Scudder has published an important monograph on the remains of these insects; several hundred specimens collected in the famous Florissant deposits have "not only the venation of the wings completely represented, with all their most delicate markings, but also the slender and fragile legs with their clothing of hair and spurs, and to some degree at least the antennæ and palpi. Even the facets of the compound eyes are often preserved as in life." With such

\* Comptes Rendus, cxviii. (1894) pp. 926-9. † Tom. cit., pp. 1106-8.

‡ Ver. Zool.-Bot. Ges. Wien, xlv. (1894) pp. 1-8 (1 pl.).

§ Proc. Amer. Phil. Soc., xxxii.; see Amer. Natural., xxviii. (1894) pp. 532 and 3.



material it is not to be wondered at that many interesting results were obtained.

Twenty-nine new species belonging to ten genera of Limnobiinæ, and twenty-two belonging to five genera of Tipulinæ are described; they are all now extinct, and none are identical with any of the few described tertiary Tipulidæ of Europe; eight of the fifteen genera of the Florissant basin appear to be extinct; there are no extinct groups higher than genera, though some of them are of a somewhat striking character.

The relative importance of the two sub-families of Tipulidæ, though differing in Europe and America both in tertiary and recent times, was much the same, on each continent, in tertiary times as now; in the relative preponderance of the different tribes of the Limnobiinæ the American tertiary fauna exhibits a somewhat closer agreement with the European tertiary than with the existing American fauna.

No certain indications of a warmer climate, such as is shown by other groups, is given by the American tertiary Tipulidæ.

### β. Myriopoda.

**Myriopoda of North America.**\*—Dr. L. M. Underwood edits the already published and the posthumous papers of the late C. H. Bollman; that of the latter which is of greatest interest deals with the classification of the Myriopoda. The great differences between the two principal orders of the group as generally understood are recognized, and it is proposed to call Etymochila the group which contains, as subclasses, the Syngnatha and the Hexapoda (Insecta), as it is the only group of Arthropods that has a true labium. The name Myriopoda is confined to the Diplopoda and Pauropoda; for the latter subclass the name Monopoda is proposed.

The Diplopoda are divided into two suborders, the Chilognatha and Podochila (Polyxenidæ); the former break up into three orders:—(1) Colobognatha, with the family Polyzoniidæ; (2) Helminthomorpha, with the families Julidæ, Craspedosomidæ, Callipodidæ; and (3) Oniscomorpha for the Glomeridæ.

The Syngnatha† are divided into the Anamorpha and the Epimorpha; the former containing the Lithobiidæ, Cermatobiidæ, and the Seutiggeridæ, and the latter the Scolopendridæ and Geophilidæ. For the diagnoses reference must be made to the original.

**Structure of Pauropus.**‡—Herr P. Schmidt gives a preliminary report of his investigation of the structure of *Pauropus Huxleyi* Lubbock. It may be enough at present to note his general conclusions:—(1) *Pauropus* has no primitive characters, less at any rate than the Chilopoda; (2) it is the simplest Myriopod as yet described, but its simplicity is secondary and degenerative; (3) it is most nearly related to the Diplopoda, and among these to the Pselaphognatha (Polyxenidæ).

### δ. Arachnida.

**Lateral Eyes in Galeodidæ.**§—Mr. H. M. Bernard announces the discovery of lateral eyes in Galeodidæ, a group supposed to be unique

\* Bull. U.S. Nat. Mus., No. 46 (1893) pp. 153-62. † Tom. cit., pp. 163-7.

‡ Zool. Anzeig., xvii. (1894) pp. 189-96 (2 figs.).

§ Ann. and Mag. Nat. Hist., xiii. (1894) pp. 517-20 (3 figs.).

among the larger Arachnida from not possessing them. They have probably been missed from the alteration in position, for they have been shifted over the edge of the dorsal surface on to the lateral so that they look downwards and forwards. Their irregular form and, perhaps, their position indicate that they are undergoing atrophy; they have lost all traces of a lens, and as the chitin is thinned away over them, we have merely minute eyes that are little more than plugs of pigment in deep chitinous pits.

**Endosternite of Arachnids.\***—Mr. W. Schimkéwitsch refers to Mr. Bernard's recent attempt to homologize the apodemes of *Galeodes* with the endosternite of other Arachnids,† and points out that treatment of *Androctonus bicolor* with caustic potash and a series of transverse sections of a young Scorpion will show that the apodemes of *Galeodes* are entirely represented by the less developed apodemes of the Scorpion.

**Parthenogenesis of Sarcoptidæ.‡**—M. E. Trouessart finds distinct parthenogenesis in *Syringobia chelopus* Trt. and Neum., a Sarcoptid of the sub-family Analgesinæ, and a parasite on the feathers of the wader *Totanus calidris*.

At the time of the annual moult, which precedes the southward migration of the bird, a few nymph-individuals of *Syringobia* enter the young feathers by the superior umbilicus. If there are individuals of both sexes, the colony illustrates the normal series; but if all be female, the nymphs increase in size and become parthenogenetic. In the warm country the young forms issue from the quill, and normal colonies live on the barbs as usual. On the approach of the spring migration northward, the young enter the quill by the superior umbilicus, and form both normal and parthenogenetic colonies, while the external colonies disappear. Thus the parthenogenesis is determined by two factors—hibernation in the quill, and the absence of males in a given colony.

**Structures resembling Dermal Bones in Limulus.§**—Dr. W. Patten finds, under the external chitinous covering of the body of *Limulus*, remarkable bone-like structures; they consist of a network of chitinous bars with irregular spaces through which blood-vessels and nerves ramify. In some, probably very old, individuals, the axis of each bar is densely crowded with spindle-shaped cavities or lacunæ; their long axes are parallel to the long axis of the bar, and at times many may be seen to be connected at one end with a very fine tubule, or canaliculus, which runs radially towards the periphery. The lacunæ arise on enlargements of the distal ends of these canaliculi.

The author insists on the remarkable character of this dermal structure, quite unlike anything known in any other Invertebrate; though he ventures to predict that similar structures will be found in Trilobites and Merostoma, when they are properly investigated. Indeed, the only animals known to show such an exoskeleton as *Limulus* are some of the fossil fishes which are called Cephalaspidæ, and the most striking resemblance is shown by *Pteraspis*.

\* Zool. Anzeig., xvii. (1894) pp. 127 and 8.

† See *ante*, p. 192.

‡ Comptes Rendus, cxviii. (1894) pp. 1218–20.

§ Anat. Anzeig., ix. (1894) pp. 429–38 (4 figs.).

In addition to its dermal skeleton *Limulus* has three other kinds of skeletal structures of very obvious significance; (1) cartilaginous gill-bars, which are histologically very much like the cartilage of *Petromyzon*; (2) segmentally arranged cartilages partially surrounding the ventral cord; and (3) the cartilaginous cranium. This last is not a simple plate, as described by Lankester and others, but "the whole forms a perfect picture of a simple cartilaginous cranium such as we might expect to find in some primitive Vertebrate."

The author urges that we can only fail to regard these facts as proof positive of genetic relationship at the cost of destroying the very foundations of the science of Morphology.

#### e. Crustacea.

**Physiology of Decapod Crustacea.\***—M. L. Cuénot has published an extended memoir detailing the results which we have already† noted. New paragraphs deal with the presence in the connective tissue of cells containing albuminoid spheres; these may be considered as elements of reserve, for their contents disappear completely after a prolonged fast. In *Galathea* and *Palinurus* fat-cells were sometimes observed.

In the Brachyura the integument, on each side of the pericardium, is provided with a pouch formed by connective tissue, which is traversed by strong muscular bundles; these pouches, the function of which is unknown, are found in a rudimentary condition in the Anomura and the Palinuridæ.

The amœbocytes of the blood represent the different stages in the development of one and the same element; the young (hyaline cells) gradually form eosinophilous grains; when the eosinophilous or mature cell degenerates the grains appear to be dissolved in the blood. The degenerate cells are swallowed by the young, and so disappear from the circulation. The lymphatic gland which produces the hyaline cells invests the dorsal surface of the masticatory stomach.

There is only one type of phagocytes in Decapods; this is seen in the young stages of amœbocytes; they have either a neutral (*Astacus*) or acid reaction, and are capable of slowly digesting albuminoids. These phagocytes are attracted by solid injected particles, degenerate or diseased organs, or dead parasites; they free the organism from them, either by enclosing them in a sort of isolating cyst or by digesting them, but they are always inactive towards living parasites of every kind; this peculiarity is, no doubt, related to the presence of a chitinous carapace.

**Median Eye of Adult Crustacea.‡**—Dr. H. C. Bumpus has a preliminary note stating that he has been able to trace the median eye, so generally present in larvæ and lower Crustacea, through several Brachyura, Macrura, Schizopoda and Stomatopoda, and in no case has he found the organ absent. In some, but not all cases it is easily seen from the exterior. Further details are promised.

**Correlation of certain External Parts of *Palæmon serratus*.§**—Mr. H. Thompson, following the methods of Prof. Weldon, has deter-

\* Arch. de Biol. xiii. (1894) pp. 245-303 (3 pls.). † See *ante*, p. 194.

‡ Zool. Anzeig., xvii. (1894) pp. 176 and 7.

§ Proc. Roy. Soc. Lond., lv. (1894) pp. 234-40.

mined the values of correlated variations in a number of the hard exoskeletons of the common Prawn. One thousand adult females were obtained from Plymouth, and twenty-two measurements were made of each. The values were found to range themselves with a fair degree of symmetry round the median value, and to correspond more or less accurately to calculated probability curves.

**Blind Cambarus from Florida.\***—Dr. E. Lönnberg has found in subterranean water in Florida a blind species which he proposes to call *Cambarus acherontis*; this is the third blind species found in the United States, and is quite distinct from the more northern forms.

**Copepoda of Liverpool Bay.†**—Mr. I. C. Thompson, in his revised report, states that whereas, before 1885, only six species of marine Copepods were known from the Liverpool area, 136 are now enumerated, of which 18 are new to the British species, and of these 11 are new to science. The report must, therefore, be studied both by those who are interested in the British fauna, and those who are specialists in Copepoda.

**Cirripedia.‡**—M. A. Gruvel, in an extended memoir, deals with what he calls normal Cirripedes; he finds little differences in the broad lines of their organization; owing to the restricted area investigated he is unable to generalize or to consider the relations of these Cirripedia to the other Entomostraca. The structure of the calcareous plates of the test of *Balanus tintinnabulum* has been fully investigated, and salivary glands, the presence of which was not suspected, have been demonstrated to exist. The possession by *Balanus* of respiratory setæ is described, and the resemblance of the nervous system of the Balanidæ to that of the Lepadidæ is pointed out; ganglia, whose function is to augment the tactile secretion, have been discovered in the cirri, and vesicular organs in *Lepas anatifera*. The resemblances between the eye of Cirripeds and of other Entomostraca are pointed out.

In the gastric juice two free acids have been found, one organic and present in small quantities, the other mineral and in greater quantities. The acid reaction of the leucocytes is demonstrated, and the author describes the part that they play in digestion and excretion. Experiment has shown that the red pigment of the blood has no respiratory function; excretion is effected by the renal glands, the pigmented wall of the body, and the cement glands. Cirripedes are able both to taste and to smell, but not to hear. M. Gruvel has seen for himself the process of reciprocal fecundation, and has reason to believe that self-fertilization also occurs.

#### Vermes.

##### a. Annelida.

**Structure of Euphrosyne.§**—Prof. W. C. McIntosh gives an account of some parts of the anatomy of this Annelid—the body-wall, the aruncle or highly sensitive tongue-shaped organ, the branchiæ, the

\* Zool. Anzeig., xvii. (1894) pp. 125-7.

† Trans. Liverpool Biol. Soc., vii. (1893) pp. 175-230 (26 pls.).

‡ Arch. Zool. Gén. et Expér., i. (1893) pp. 401-610 (9 pls.).

§ Quart. Journ. Micr. Sci., xxxvi. (1894) pp. 53-66 (2 pls.).



dorsal cirri, the alimentary canal, the circulatory system, the nephridia, and the generative elements are respectively passed in review, but details only are given.

**Young Stages of Magelona.\***—The same author takes the opportunity of the discovery of several stages of the young of this worm to add to our knowledge of some details. Claparède's unknown larval *Spio* appears to be the larva of a species not unknown at St. Andrews.

**Auditory Organs of Alciopidæ.†**—M. E. Béranek notes that although Greef was wrong in interpreting glandular structures near the eyes of Alciopidæ as auditory sacs, otocysts are indeed present. They are two little sacs attached in the larva to the first segment of the trunk; they arise as ectodermic buds, include external epidermis, internal sensory cells, unicellular glands and organic (granular) otoliths of nuclear origin, and are innervated by the sub-œsophageal ganglion. In *Asterope* there are four sacs, the second pair innervated from the second ventral ganglion, and on the other segments of the body the parapodial cirri are sensory. In fact, the otocysts of these Annelids are transformed cirri. The type found in *Arenicola* and other forms, and in the Trochophore larva, is of course quite different and doubtless more primitive.

Béranek is not inclined to accept the view of Eisig and others that the lateral sense-organs of Vertebrates are homologous with those of Annelids. He believes that the auditory organs of bilateral Metazoa arise independently in each phylum. In Molluscs and Crustaceans, the otocysts combine the two functions of hearing and orientation; those of Vertebrates are (*pace* several authorities) for hearing only. It may be said that the two functions are dependent on one—that of receiving vibrations from the surrounding medium; but the sense of orientation is a complex physiological resultant in which various sensory organs besides otocysts may concur.

### B. Nematelminthes.

**New Genera of Nematodes.‡**—Mr. N. A. Cobb describes ten new genera and twenty new species of Nematodes; they were all free-living and marine, and came from the Atlantic, Indian, and South Pacific Oceans. *Tricoma* (*T. cincta*) has the cuticle so coarsely striated as to suggest the segmentation of an Annelid. *Pelagonema* (*P. simplex*, from Ceylon) is related to *Oncholaimus*, but there are no teeth on the walls of the pharynx. *Demonema* (*D. rapax*, from Naples) is allied to *Enoplus*, but wants the distinct teeth characteristic of that genus. For *Platycoma* (*P. cephalata*, from Naples) the generic are not distinguished from the specific characters. *Bathylaimus* (*B. australis*, from Port Jackson) is apparently related to *Oncholaimus*, but, like *Pelagonema*, has not its teeth. *Synonchus* (*S. fasciculatus* and *S. hirsutus*, from Naples) is also related to *Oncholaimus*; the dorsal gland has the peculiarity of emptying into the lumen of the œsophagus at some distance from the mouth, a fact which supports the opinion that these organs are salivary glands.

\* Quart. Journ. Micr. Sci., xxxvi. (1894) pp. 66-74 (1 pl.).

† Rev. Suisse Zool., i. (1893) pp. 463-500 (1 pl.).

‡ Proc. Linn. Soc. N.S.W., viii. (1894) pp. 389-421 (50 figs.).

*Laxus* (*L. contortus*, from Naples, and *L. longus*, from Port Jackson) is short-necked, slender, and flexible. *Chroma*[*o*]*gaster* (*C. nigricans*, from Naples, and *C. purpurea*, from Port Adelaide) is probably closely allied to, if not identical with, De Man's new genus *Siphonolaimus*. *Solenolaimus* (*S. obtusus*, from Naples), is short-necked, has a narrow pharynx, and asymmetrical female sexual organs. *Fimbria* (*F. tenuis*, from Ceylon) has hairs abundant on the tail, but not conspicuous elsewhere; the mouth is surrounded by minute bristles, or bristle-bearing papillæ.

**Structure of Nematodes.\***—Dr. L. A. Jägerskiöld has examined *Ascaris spiculigera* which has been found in thirty-one species of Birds, *A. osculata* found in six, *A. decipiens* in seven, and *A. simplex* in eight species of Cetacea, as well as a few other Ascarids. Of most of these, as of *Oxyuris flagelloides* sp. n., from the cocoon of *Atherura armata*, and of *Ichthyonema pellucidum* sp. n. from the body-cavity of *Tetrodon stellatus*, he gives somewhat fully detailed accounts.

Diesing and v. Drasche, on account of the structure of the excretory organ and digestive canal, formed the genus *Peritrachelius* for *Ascaris osculata*, *spiculigera*, *lobulata*, *decipiens*, and *simplex*; the same kind of digestive canal is, however, found in many other species of *Ascaris*, and their type of excretory organ is not confined to them. At present we know the anatomy of too few Ascarids to justify us in breaking up the genus. For the details of anatomy of the described species, reference must be made to this somewhat lengthy paper.

**Heterakis Sonsinoi.†**—Dr. v. Linstow gives one of his careful descriptions of a new Nematode from the terminal part of the intestine of *Chamocles vulgaris* where it was found by Dr. Sonsino. The spicula are of the same length, and not unequal, as is often the case in this genus. The female was 6 mm. long, and 0.37 mm. broad; the ova appear to be deposited in the intestine of the host.

**Nematode of Coffee-Disease.‡**—Dr. E. Göldi describes the Anguillulid parasite—*Meloidogyne exigua* g. et sp. n.—which he has discovered as the primary cause of the disastrous coffee-disease in Brazil. The memoir gives full particulars of the disease, of its effect on the plant, and of what is known of the life-history of the parasite.

#### γ. Platyhelminthes.

**Planocera inquilina.§**—Mr. W. M. Wheeler describes this new species of Polyclad which is found commonly at Vineyard Sound, living on *Sycotypus canaliculatus*. The adult is 6 mm. long by 4 mm. broad, and is devoid of pigment; in consequence of this the nervous system may be traced without difficulty, and seems to closely agree with Lang's descriptions of the same system in *P. Graffi*. Remarkably clear pictures of the beautiful plexus and its connection with the brain may be obtained by killing in hot corrosive, staining for twelve hours in

\* Zool. Jahrb. (Anat. Abth.), vii. (1894) pp. 449-532 (5 pls.).

† Centralbl. f. Bakteriol. u. Parasitenk., xv. (1894) pp. 733-5 (3 figs.).

‡ Archiv. Mus. Rio de Janeiro, viii. (1892) pp. 9-121 (5 pls., 1 map).

§ Journal of Morphology, ix. (1894) pp. 195-201 (2 figs.).

Czokor's alum cochineal, and after dehydrating, mounting in gum Sandarac dissolved in absolute alcohol.

The reproductive organs are remarkable for their simplicity, and no seminal vesicle or granule gland could be detected; a great number of spermatozoa were found in all parts of the body, and there is, undoubtedly, in this species a true "hypodermic impregnation" (Whitman). In the aquarium the sexually mature animals crawl over one another, and thrust their stylet-shaped penes into one another's bodies at any point. From this point, which may be found in sections, the spermatozoa travel through the tissues to the uteri.

As soon as the mature ova pass into the uteri the wall of the germinal vesicle fades away, and a spindle is formed with distinct polar suns, containing centrosomes. The small chromosomes, nine to ten in number, form an equatorial plate, and perhaps, undergo fission. The polar asters then grow faint and vanish, and the nucleus returns to the resting-stage. The author was unable to follow the development beyond the first cleavage stages.

The animals did not survive long in the aquarium; a slow process of dissolution set in at some point on the body and gradually more and more of the tissue melted away till only the tentacle- and brain-region remained; this crept about for a few days, but finally it, too, disintegrated.

**New Marine Triclad.\***—Mr. W. M. Wheeler describes, under the name of *Synœolidium pellucidum*, a Triclad found in the gill-books of *Limulus polyphemus*. One of its most striking characters is its apparent metamerism, for the nervous system is quite as regularly metameric as in *Gunda*, and preliminary observation pointed to a pair of gut-diverticula, a pair of testes, and a pair of vitellaria to each transverse and each pair of lateral nerves; closer observation, however, showed that the gut-diverticula are very irregular in arrangement and number, and that the generative organs varied with them. We have, therefore, a condition which is intermediate between *Gunda* and the freshwater Triclads.

The most striking peculiarity of the Triclad parasite of *Limulus* is the duplicity of the uterus, and the independent openings on the surface of the body; this, coupled with the complete absence of rhabdites, leads Mr. Wheeler to the institution of the family Bdellouridæ, as co-ordinate with the Planariidæ and Geoplanidæ; they may be defined as ectoparasitic marine Triclads without auricular folds at the cephalic ends, without pigment, except in the two eyes, and without rhabdites; with two uteri opening by discrete ostia lateral to the longitudinal nerves, and with ejaculatory ducts opening separately very near the penis. The genus *Bdelloura* has two (large) species, *B. candida* Girard, and *B. propinqua* sp. n.; *Synœolidium pellucidum* g. et sp. n. is small. The characters assigned by Verrill to the family which he has proposed for *B. candida* are not in all respects satisfactory.

*B. candida* oviposits during May and early June when the King-Crabs return from the deep water to the sandy beaches to breed, and the passage of the parasites from one crab to another must be favoured by the

\* Journal of Morphology, ix. (1894) pp. 167-94 (1 pl.).

prolonged coitus of their hosts. *Syncelium* oviposits in late July and early August, when the gills are deserted by the young of *B. candida* for the basal joints of the cephalothoracic appendages.

**Turbellaria of Liverpool Marine District.\***—Mr. F. W. Gamble who has already investigated the Turbellaria of Plymouth, has made a hasty inspection of those in the Liverpool district. Twenty-eight species representing twenty-three genera have been found at Port Erin, and of these five are new to Britain. Indeed, it seems that we are only beginning to ascertain the richness of this portion of the British fauna. An interesting account is given of the observed species.

**Life-history of Holostomidæ.†**—Prof. M. Braun reports the results of a series of feeding experiments conducted by Herren A. and O. Ehrhardt. They have shown that *Diplostomum volvens* v. Nordm., abundant in the eyes of *Leuciscus rutilus*, becomes *Hemistomum spathæcum* Dies. in the food-canal of *Larus ridibundus*; *Tetracotyle ovata* v. Linst., common in *Acerina cernua*, becomes in the same gull *Holostomum variegatum*; *Hemistomum excavatum* from *Ciconia alba* comes from a larva in *Rana temporaria*; *Holostomum variabile* Nitzsch arises in *Ulula aluco* and *Buteo vulgaris* from *Tetracotyle colubri* v. Linst.

**Helminthological Notes.‡**—Dr. v. Linstow describes *Tetracotyle typica* from *Limnæa stagnalis* and *Nepheleis vulgaris*, *Distomum* (*Echinostomum*) *pungens* n. sp. from *Podiceps minor*, *D. macrolaimus* n. sp. from *Vesperugo pipistrellus*, *Tænia* (*Davainea*) *spiniosissima* n. sp. from *Turdus merula*, *Filaria ochracea* n. sp. in *Thymallus ochracea*, *F. pulicis* n. sp. in *Gammarus pulex*, and some other parasites.

**New Human Liver Fluke.§**—Prof. M. Braun calls attention to the species of *Distomum* described by Winogradoff as *D. sibiricum*, and expresses his opinion that it is identical with *D. felineum* of the cat and dog. It is, however, a new observation that it invades and has a serious effect on the human liver; in some parts of Russia it would appear to be not rare.

**Valvular Apparatus in Excretory Vessels of Tæniæ.||**—Herr E. Köhler has investigated the distribution of this apparatus, in regard to which there has been much difference of opinion. In Cysticeroid forms (*T. solium*, *T. saginata*, *T. crassicollis*, *T. crassiceps*, *T. polyacantha*, *T. serrata*), the valvular apparatus is present. The parenchymatous tissue of the body is continued into it; the free margin is a structureless membrane; there are no muscular elements. Among cystoid forms the conditions are different; in the short-jointed *T. perfoliata* there is no valvular apparatus; in the Dipylidea (*T. cucumerina* and *T. expansa*) no trace was found; in the bird-tapeworms (*T. serpentulus* and *T. gutturosa*) it was likewise sought for in vain; finally, in *T. litterata* it is well developed.

\* Trans. Liverpool Biol. Soc., vii. (1893) pp. 148-79 (3 pls.).

† Zool. Anzeig., xvii. (1894) pp. 165-7.

‡ Jenaische Zeitschr. f. Naturwiss., xxviii. (1894) pp. 328-42 (2 pls.).

§ Centralbl. f. Bakteriol. u. Parasitenk., xv. (1894) pp. 602-6.

|| Zeitschr. f. wiss. Zool., lviii. (1894) pp. 385-401 (2 pls., 2 figs.).



*Tænia Brandti*.\*—Dr. N. Cholodkowsky describes a new species of Tapeworm of which he has obtained 8 specimens, 5 from cattle and 3 from pigs. The fact that the fully formed tapeworm occurs in the intestine of pigs imparts a certain interest to *T. Brandti*, which in many respects resembles *T. ovilla* Rivolta, chiefly if a ripe proglottis of *T. ovilla* be compared with an unripe one of *T. Brandti*. The latter is distinguishable from *T. ovilla* by the following characters:—(1) its greater size; (2) by the greatly branched shape of uterus, which in *T. ovilla* is quite simple; (3) by the peculiar relations of the vesiculæ seminales; (4) by presence of accessory male sexual organs.

*T. Brandti* is about 3 m. long and 10 mm. broad at its distal end. The head is a roundish cube, devoid of hooklets, has four large suckers and a short stumpy rostellum.

*Polycercus*.†—Prof. W. A. Haswell and Mr. J. P. Hill give an account of this remarkable cystic worm, which was first found at Odessa in *Lumbricus terrestris*, and does not seem to have been reinvestigated since. A form of undoubted affinities with it has been found in *Didymogaster sylvicola*, a common earthworm in New South Wales. Feeding experiments to breed the *Tænia* have not been successful.

The infested earthworms usually contain an immense number of cysts, which adhere to the outer surface of the alimentary canal; each cyst contains a number of fully formed cysticeroids, but nothing was seen of hooked embryos. The history appears to be this—the hooked embryo develops into a rounded cellular body, which becomes enclosed in a cyst, which is probably entirely of an adventitious character; buds are given off from the periphery of the mass and develop into cysticeroids which become free in the interior of the cyst; the head, with its hooks and suckers, is developed from the central portion of the solid bud; the middle layers form the “body” and the outermost the caudal vesicle.

The authors point out that in many cysticeroids there appears to be a progressive invagination of the anterior parts within those lying behind; this condition of things is clearly secondary, being brought about in adaptation to special circumstances. In *Polycercus* this adaptation may be said to reach its furthest known limit; there is no invagination in the strict sense, but the parts of the cysticeroid are actually developed one within the other, and it is not till the cysticeroid is about to pass into the adult Cestode, that by a process of evagination the parts assume their normal and primitive relations to one another.

In some respects *Polycercus* is more nearly related to *Staphylocystis* than any other known form of Cestode larva; in both the development is a process of external proliferation from the product of the hooked embryo, though the essential similarity is somewhat disguised by the development in *Polycercus* of an adventitious investment, which is not represented in *Staphylocystis*.

#### δ. Incertæ Sedis.

*Balanoglossus* from New South Wales.‡—Mr. J. P. Hill makes the interesting announcement that a species of *Balanoglossus* has been

\* Centralbl. f. Bakteriöl. u. Parasitenk., xv. (1894) pp. 552-4 (2 figs.).

† Proc. Linn. Soc. N.S.W., viii. (1894) pp. 365-76 (2 pls.).

‡ Tom. cit., p. 324.

found in abundance on the coast of New South Wales. Some are bright orange anteriorly, and colourless posteriorly, while others are colourless throughout; this is probably a sexual difference. The largest example measured, when moderately extended, seven inches.

Food of *Sagitta*.\*—Mr. A. T. Masterman's article under this head consists of two parts; attention is drawn to Mr. T. Scott's proof that *Sagitta* is one of the enemies of our food-fishes; the original portion of the article deals with young *Sagittæ* serving as food for *Obelia*, on which, as the author thinks, they had themselves meant to browse.

Protandric Hermaphroditism in *Myzostoma*.†—Dr. W. M. Wheeler, from a study of the four Mediterranean species of this parasite, finds that the true ovaries have been overlooked. He finds that they are the organs which Nansen noticed, and called problematical organs; under high powers they are seen to be solid proliferations of the peritoneal epithelium over a very restricted area. Especially in young forms karyokinetic figures may be detected in the minute cells. Three-celled clusters are formed, and break away, migrating into the ducts leading to the smaller cæcal ramifications of the "ovary"; they ultimately attach themselves to the epithelial walls of the cæca and begin to grow. Their course of development so much resembles that of *Chætopods* as to afford an additional indication that the *Myzostomida* are degenerate Annelids; it follows also that the so-called ovary is the true body-cavity.

As these bodies are also found in the complemental males, it is clear that these small individuals are not really males, but hermaphrodites, functionally male in youth, functionally female in old age.

Rotifera of Württemberg.‡—Herr L. Bilfinger has done good service in publishing, in two papers, a list of the 208 species of Rotifers which, in the course of five years, he has found in various parts of Württemberg, with critical remarks, sometimes confirming and sometimes correcting and amplifying previous observations.

This is the kind of work most needed, and will greatly assist in rendering perfect a second edition of Hudson and Gosse's Monograph whenever such a work may be undertaken.

Herr Bilfinger has not only recorded as occurring in Württemberg most of the commoner species, but has also found a number of very rare Rotifers, such as *Apsilus cutiformis*, *Floscularia mutabilis*, and *F. Hoodi*; the last named has previously been found in Scotland only. Two species, *Stephanops emarginatus* and *Proales caudata*, are described as new.

#### Echinoderma.

Anatomy and Development of *Cucumaria glacialis*.§—Herr T. Mortensen finds that the long calcareous corpuscles of this Holothurian have a smooth, thin edge, which allows the corpuscles to slide a little over one another when the animal is contracted. The corpuscles in the

\* Ann. and Mag. Nat. Hist., xiii. (1894) pp. 440 and 1 (2 figs.).

† Zool. Anzeig., xvii. (1894) pp. 177-82.

‡ Jahreshefte Ver. Vaterl. Naturkunde in Württ., 1892, pp. 107-18, and 1894, pp. 35-65 (2 pls.).

§ Zeitschr. f. wiss. Zool., lvii. (1894) pp. 704-32 (2 pls.).

anterior invaginable part of the skin all have their long axes set transversely to the long axis of the body, so as to afford the least resistance on contraction. The skin of this part of the body is much thinner and weaker than the rest.

The whole of the water-vascular system is surrounded by an elastic membrane, as is probably the case in all Echinoderms; the degree of development of the membrane in the podia depends on the needs of the animal. The stone-canal is fused with the efferent duct of the gonads. Spermatogenesis is so far different from that of all other known Echinoderms that long spermatogemmæ are formed. The brood-pouches are invaginations of the skin which are always open to the exterior; from the way in which the ova pass into them it may be supposed that the eggs are deposited on the sea-bottom, and that the animal creeps over them, and takes them into the pouches; at this time there are probably peristaltic movements of the circular musculature of the efferent ducts of the pouches. There is no direct connection between gonads and brood-pouches. The generative products are formed at different periods, separated from one another by intervals of unknown length, during which no generative products are formed.

Cleavage of eggs 1 mm. in diameter is not, as in other Echinoderms, total; the cleavage-nuclei are scattered in the midst of the large unsegmented yolk, and migrate, as they increase in size, to the periphery, where they form the ectoderm. The yolk breaks up into large spheres. When the young are almost complete they have the mouth closed by a plate of cells, so that no nutriment can be ingested at this stage. The brood-pouches probably serve only for the protection of the young. The gonads arise in the mesentery in the form of a small mass of cells, which at first gives off a pair of genital tubes, and later on the duct. Later on other genital tubes arise by pairs from those already formed.

**Development of a Holothurian Spicule.\***—Mr. K. Kishinouye describes and figures the various stages in the growth of the spicules of a Japanese Holothurian, an abstract of which would be hardly intelligible without the ten illustrative figures.

#### Coelentera.

**Asexual Reproduction of Madrepora.†**—Dr. G. v. Koch has studied the gemmation of the skeleton in *M. echidnæa* and *M. surculosa*. The buds arise from processes of the costæ of the mother calycele, which first form blunt triangular projections above the edge of the costa, and then form thin bridges of connection, which are the first signs of a wall. The later swallow-nest-like form of the bud is due to the more rapid growth of the two outer costal processes; of the septa the two primaries are direct continuations of one costa of the mother-polyp, while the others are partly direct continuations of the costæ and partly new formations. In older buds the costæ increase by fission.

**Flabellum anthophyllum.‡**—Prof. H. de Lacaze-Duthiers points out that this coral, which he has studied on the shores of the Gulf of Lyons,

\* Zool. Anzeig., xvii. (1894) pp. 146 and 7.

† Abh. Nürnberger Nat. Gesellsch., 1893, 18 pp., 1 pl. and 3 figs. See Zool. Centralbl., pp. 101 and 2 (2 figs.).

‡ Comptes Rendus, cxviii. (1894) pp. 1013-9.

offers a remarkable example of the modifications which may be effected in the form and mode of fixation of an animal by the different development of one of its parts. When quite young the polyp is cylindrical, and its septa form two cycles which may be represented by the formula  $6 + 6$ . As is well known, the adult has an oval calyx. By the continuous study of growing forms the author has been able to explain how the change is effected. When a polyp is 2 to 3 mm. high, one of its tentacles, the corresponding cavity, and the edge of the peristome become more developed. The deposit of calcareous particles follows the activity of this lateral growth, and the result is that the edge of the calyx is prolonged, by curving towards the surface by which the polyp is fixed. When the tissues, thus elongated, come in contact with that surface, a connection is established between it and them, sclerites are deposited at this point, and henceforward, the polyp is doubly fixed, first by its primitive base, and, secondly, by the edge of its calyx. On the prolonged and curved part deposits are formed as in the rest of the calyx, but they are also curved, while retaining the size proportional to the order of cycle to which they belong. The calyx now begins to be oval, and the whole of its edge is no longer tangential to a plane perpendicular to the axis of the cylinder. As the animal grows and its tentacles increase in number, the side which was at first inclined is again gradually raised. It is especially at this end of the long axis of the oval that there are produced the increase of the elements and of new groups of chambers. The oval thus gets longer, and the flabellate form becomes more and more marked. It is, moreover, at this end that the new groups of septa which are added are sometimes very different in size as compared with the lateral groups.

Prof. Lacaze-Duthiers points out that we have here an instance of the utility of following the development of organisms so as to recognize and properly interpret the successive changes through which they pass; it is too in this way that Zoology may be called experimental.

**Post-embryonic Development of Fungia.\***—Mr. G. C. Bourne has been able to study the various phases in the life-history of *Fungia*, from the youngest fixed form with twelve septa up to the fully formed free disc-shaped adult, and of these he now gives a detailed account.

For convenience and clearness he makes use of a definite terminology, applying the term trophozooid to the individual Caryophyllia-like form which is developed directly from the ovum; this may give rise to one or more *anthoblasts*, by which name the buds may be distinguished from the individual which gave rise to them; two or more anthoblasts united to form a colony may be called an *anthocormus*. The discoid Fungia-form, whether free or attached, is an *anthocyathus*, while the term *anthocaulus* is applied to the pedicle which carries the anthocyathus, and after the detachment of the latter remains in connection with the cormus, or, in the case of isolated trophozooids, remains fixed to a foreign body, and usually gives rise to a new anthocyathus.

Attention is called to the fact that the septa in the trophozooid, and in the anthoblasts formed from it, arise in the same way and have the same relations as in any ordinary solitary coral; that the anthocyathus

\* Sci. Trans. Roy. Dublin. Soc., v. (1893) pp. 205-38 (4 pls.).



is formed by the growth of these selfsame septa in a horizontal direction, and the intercalation of one or two orders, in addition to those already existing, and that the whole coral structure of the adult *Fungia* is directly derived from the pre-existing similar structures in the trophozooid or anthoblast.

With regard to the presence or absence of a theca, Mr. Bourne is opposed to Ortmann, and is on the same side as Von Koch; he declares that from the first the young *Fungia* has a compact lateral theca which is not porous, is not formed by casual fusion of synapticulæ, and is represented by a basal theca in the adult.

The detachment of the anthocaulus appears to be due to a degeneration of the tissue-cells in the region where detachment takes place, and the decay of the corallum appears to follow on the degeneration of the tissues. This view is based on the assumption that the hard parts of the living coral are in some manner intimately connected with the living protoplasm of the tissues, and that their integrity is dependent on the integrity of the tissues which give rise to them. At any rate, in any coral a marked distinction can be observed between those parts of the corallum which are clothed by the living tissues of the polyps and those which are not. The former are pearly white, translucent, and very hard; they seem to be more resistant to the action of solvents, and especially to the attacks of boring parasites; *Achlya penetrans*, for example, is an invariable accompaniment of the detachment of the anthocyathus. Between such coral and that which has been deserted by living tissue, microscopical examination shows no difference in structure, the greater transparency and the more distinctly crystalline structure being the only feature of the former.

In conclusion, some of Dr. Ortmann's generalizations are criticized, and it is pointed out that he has been led to adopt an untenable hypothesis by neglecting the salutary rule that, in the explanation of adult structure, due weight must be given to developmental history.

**Structure of Tentacles of *Apolemia uvaria*.**\*—M. V. Willem has investigated the tentacles of this Siphonophore; they have a central cavity which has at its free end a hitherto unnoticed orifice, which probably serves for the evacuation of some effete products. The cells of the lining endoderm vary in character in different parts, but they are chiefly absorbing in function, and the author has been able to trace into them the fluid substances digested by the gastrozooids, and injected by them into the general nutrient system of the colony. The funnel-shaped cells are provided with a vibratile flame which drives the nutrient substances into them, and they are, therefore, not excretory, as Chun thought, but absorbent. Other absorbing cells have a simpler mechanism, fatty globules penetrating directly into them. More distally in the tentacle, there are three longitudinal pads which can close the cavity; the cells of these are able to emit fine pseudopodia which seize on nutrient particles. Still more distally the cavity dilates, and here disintegrated particles are found, which probably escape by the terminal orifice.

**Regeneration in *Obelia*.**†—Mr. C. B. Davenport has experimented on *Obelia commissuralis* by cutting it at different levels in order, if

\* Bull. Acad. Roy. Belg., lxiv. (1894) pp. 354-63 (1 pl.).

† Anat. Anzeig., ix. (1894) pp. 283-94 (6 figs.).

possible, to discover something as to the distribution and possibilities of embryonic tissue.

The whole stem and the hydranth may be reproduced after a cut through the stalk at any of the levels. A few rings only and the hydranth may be reproduced after a cut through the stalk at any of the levels. The nearer the cut to the proximal end, the greater the percentage of cases of reproduction of an entire stalk (with unsegmented tract). The nearer the cut to the distal end, the greater the *definiteness* of regeneration, the less the mean number of rings regenerated, and the smaller both the upper and lower limit in the number of rings regenerated. Such are some of his concrete results.

More generally, Davenport concludes that the regenerative tissue is not differentiated at different levels to produce different things, independent of environment; but on the contrary the embryonic tissue at all levels may produce the same things. Wholly aside from the necessary production of definite things, there may be acquired in certain embryonic tissues a *usual* method of development, independent of environment. The definiteness is a function of the distance of the cut edge from the base of the stem, and, in more general terms, of the natural frequency of a demand for regeneration. The curves of regeneration show no important indication of difference in the germ-plasma at different levels in respect to the size or form of the parts which regenerate; but there is a tendency of the regenerative tissue at all levels to produce preferably certain forms.

*Limnocnida tanganyicæ*.\*—Mr. R. T. Günther, in his second paper on this African freshwater Medusa, gives the results of his more minute examination of the material at his disposal. We know so little of the life-history of the form that it is impossible to say with certainty whether or no it is one of the *Narcomedusæ*; it is suggested that the striking similarity of the sense-organs in it and *Limnocodium* is the result of homoplasy.

A list is given of freshwater Cœlentera, and it is pointed out that there is no reason for doubting that they are all descended from marine ancestors; with regard to Lake Tanganyika, in which *Limnocnida* is found, it has been shown by Mr. Edgar Smith that it is associated with several genera of Mollusca which are perfectly unique in fresh water, and which would most certainly be considered to be marine forms, if their true habitat was unknown. A suggestion is made as to the origin of the marine fauna of this lake, but our knowledge of the geology of the country is not sufficient to enable us to be certain of its propriety.

*Lucernaria* of Port Erin.†—Mr. W. I. Beaumont, who has been working at the Isle of Man station, has found three species of this group; *Depastrum cyathiforme* is fairly abundant, *Haliclystus auricula* and *H. sp.* (? n. sp.) are rarer. The first of these, unlike most *Lucernaria*, appears to be unable to reattach itself if it becomes detached; an account is given of the various names which have been applied to this species. It is to be noted that *Depastrum*, and apparently other members of the group, are subject to much variation, especially in the

\* Quart. Journ. Micr. Sci., xxxvi. (1894) pp. 271-93 (2 pls.).

† Trans. Liverpool Biol. Soc., vii. (1893) pp. 253-63.

number and arrangement of the tentacles; the gonads vary also, though not so much. A description is given of what seems to be a new species of *Halicystus*, but it is not named.

#### Porifera.

**Embryology of Porifera.\***—Mr. E. A. Minchin gives a useful summary of the present state of our information regarding the development of Sponges, a group as to which such diverse views are held, and such opposing explanations given. Specially are the works of Delage and Maas considered.

On this subject Mr. H. V. Wilson's review † should also be consulted.

**Nutritive and Excretory Processes in Porifera.‡**—Mr. A. T. Masterman, from the study of *Grantia compressa*, finds that food-particles are chiefly ingested by the choanocytes, and that their absorption by other parts is practically of no importance. The choanocytes may become transformed into amœbiform cells, which in no way differ in appearance from the so-called mesoderm cells. These cells migrate inwards and exhibit intracellular digestion; their place is taken by fresh choanocytes which arise from transformed "mesoderm cells." The solid waste particles are excreted by amœboid nephrocytes, which burst through the limiting layer of pinnacocytes, and leave the colony, probably to disintegrate.

Although the author does not discuss the bearing of his facts on the much disputed point of the origin of the Porifera, it is clear that the fact that the cells of the inner layer are, under different conditions, mastigopod or myxopod strengthens the argument in favour of the Choanoflagellate relationship, while the absence of intracellular digestion distinguishes Sponges from Cœlentera.

**Comparative Anatomy of Sponges.§**—In the sixth of his "Studies," Dr. A. Dendy deals with the anatomy and relationships of *Lelapia australis*, a living representative of the fossil Pharetrones. This very remarkable calcareous Sponge is very rare, and has only been dredged off the coast of Victoria. As the author had suspected, the canal system belongs to the Leuconoid type, but what is most interesting is the as yet unobserved reticulated fibrous character of the skeleton; unknown in any other living calcareous Sponge, this character forms the most prominent feature in the great fossil group Pharetrones.

The spicular fibres are believed by the author to be derived from the articulate tubar skeleton of a Syconoid ancestor; reasons are given for this view, and it is pointed out that, while in *Leucandra* the spicules of the primitive articulate skeleton become scattered and disjointed, they retain their mutual relationships in *Lelapia*, where the very peculiar shape of the spicules facilitates the formation of fibres. *Lelapia* may continue to be looked on as an offshoot from the great family Grantiidæ, in proximity to *Leucandra*.

\* Science Progress, i. (1894) pp. 208-33.

† Amer. Natural., xxviii. (1894) pp. 439-41.

‡ Ann. and Mag. Nat. Hist., xlii. (1894) pp. 488-96.

§ Quart. Journ. Micr. Sci., xxxvi. (1894) pp. 127-41 (1 pl.).

Dr. Dendy does not think it advisable, in the present state of our knowledge, to introduce the family Pharetrones into the system of recent Calcarea, but to regard *Lelapia* simply as a very specialized form of the Grantiide.

#### Protozoa.

**Rôle of Acid in Protozoan Digestion.\***—Misses M. Greenwood and E. R. Saunders have made a careful investigation into the question of the intracellular formation of acid in Protozoa; their aim was to determine the relation of acid to the solution of nutritive matter in these simple organisms, rather than its actual formation; widely different types were made use of—the Infusorian *Carchesium polypinum* and the plasmodia of certain Mycetozoa. In the habits of the latter they found a striking likeness to the physiological actions of *Amœba*; the fashion of ingestion, the exclusive digestion of proteid matter, the localization of solvent processes in marked vacuoles served to recall vividly the corresponding phenomena in Rhizopods. They consider, therefore, that they are entitled to draw generalizations from these unlike forms.

The ingestion of solid matter, whatever its nature, stimulates the surrounding cell-substance to secrete acid fluid, the presence of which may be demonstrated by colour change in litmus, in Congo red, and in alizarin sulphate, and by the solution of calcium and magnesium phosphate. The outpouring of acid is not accompanied by any digestive change on nutritive matter; ingesta may indeed be stored for many hours before they are dissolved, but the formation of the digestive vacuole, whether immediate or delayed, is preceded by the development of the acid reaction, and followed by its diminution. Later on, the vacuoles and ingesta reddened by litmus become violet, and the end of normal digestion finds them pale blue, so that acid and acid combinations are alike absent. The acid is certainly free at one time, and is not carbonic, though it is, probably, an inorganic acid.

The authors contrast the relation of the secretion of acid to proteolytic activity in Protozoa with the fundamental structural changes which accompany digestion in Vertebrates, and point out that although the secretion of acid is excited by all ingesta, the true digestive vacuole is only formed under the stimulus supplied by nutritive matter.

**Protozoa of Helsingfors.†**—Dr. K. M. Levander publishes a preliminary list of Protozoa found in fresh, salt, and brackish water around Helsingfors. It includes 16 Rhizopoda, 27 Flagellata, and 72 Ciliata, of which six are new.

**Protozoa in Herpes Zoster.‡**—M. Wassiliewski, who has examined 274 cases of zona, has found among the normal epithelial cells larger cells containing a foreign body. These large cells contained 6-8 diaphanous corpuscles usually enclosed in a cyst. Similar bodies were found in epithelial cells when only slightly enlarged. They lay near

\* Journal of Physiology, xvi. (1894) pp. 441-67 (1 pl.).

† Zool. Anzeig., xvii. (1894) pp. 209-12.

‡ Correspondenz-Blätter des Allg. Aertzl. Vereins f. Thüringen, Année 24. See Ann. de Micrographie, vi. (1894) pp. 178-9.



the nucleus. From the early stage of infection up to the cystic form numerous transitions could be traced. The bodies resembled Protozoa by their mode of development at different stages, and by the spontaneous movements they evinced when heated on a slide. The author thinks that any one conversant with protozoic infection in animals would easily recognize these corpuscles.

**Infusoria of Diarrhœa.\***—Dr. E. Roos describes some Infusoria which he has found in cases of diarrhœa. In the first were Flagellata, called by Grassi *Megastoma entericum*, *Trichomonas intestinalis*, and encysted forms of *M. entericum*. In the second *Balantidium coli*, and in the third *Cercomonas hominis*. In the fourth an awl-shaped Infusorian 14–16  $\mu$  long and 3–4  $\mu$  broad. This was actively mobile, possessed an oral aperture surrounded by cilia and also a nucleus.

‡ The author recommends that the pan containing the recently passed stool should be placed inside another filled with hot water, in order to prevent the Infusoria from catching cold, and that the stools should be examined as soon as possible, for changes in the chemical reaction soon kill Infusoria.

**Dimorpha mutans.†**—Herr F. Blochmann was so fortunate as to discover some examples of this remarkable form. He is able to confirm, in general, the description of its discoverer Gruber, and to add some important details. There are six to ten small, superficially placed contractile vacuoles, and a slow streaming of the granules was observed in the pseudopodia. The presence of axial filaments is particularly interesting; they converge to a central point, where lies also the origin of the two flagella. The substance of the nucleus exhibits a distinct radial striation, and the rays appear to pass into the axial filaments. In prepared specimens the protoplasm may be seen to be separated from the nucleus by a distinct cleft.

As matters of more general interest we may note that it is now certain that flagella are not connected only with the outermost layer of protoplasm, but have a deeper origin. The fact that the axial filaments of the flagella and those of the pseudopodia arise from the same central granule affords support to Bütschli's view of the close relation between flagella and pseudopodia. *Dimorpha* is clearly more closely allied to the typical Heliozoa than was supposed, though its relations to the Flagellata are not loosened. The forms recently placed by Klebs in the genus *Dimorpha* should be placed in a new genus, for which the author proposes the name of *Dimastigamœba*.

It must not be thought that pseudopodia are never found in typically flagellate forms; Herr Blochmann has observed them in *Monas vivipara*.

**Minute Structure of Pelomyxa palustris.‡**—Miss Lilian J. Gould has studied this freshwater Rhizopod by means of sections. The protoplasm surrounding the vesicles was not homogeneous, but showed very distinct structure. The examination of sections under very high powers lent strong support to the views of Prof. Bütschli as to the foam-like

\* Zeitschr. f. Klin. Med., 1892. See Centralbl. f. Bakteriolog. u. Parasitenk., xv. (1894) pp. 616–11.

† Biol. Centralbl., xiv. (1894) pp. 197–200 (3 figs.).

‡ Quart. Journ. Micr. Sci., xxxvi. (1894) pp. 295–301 (2 pls.).

structure of protoplasm; Miss Gould was able to confirm the existence of the very fine vacuolization which he describes in *P. palustris*. The peripheral radiate alveolar border of Bütschli, said to be characteristic of froths, was clearly distinguishable in some sections.

In a consecutive series of sections of one individual, a central, more deeply staining, irregularly oval ring of apparently denser protoplasm was traceable through many sections; this appeared to be a more or less oval or spherical mass, which called to mind somewhat a central capsule.

The refringent bodies were very numerous, but were only to be seen when certain stains were used, such as fuchsin, eosin, dahlia, and others; with all stains except picric acid in turpentine, they appeared perfectly homogeneous, but with it they showed plainly a fine granulation, and sometimes contained a small, bright, crescentic area which might represent a space or cavity in the interior. Miss Gould concludes that they are almost certainly either solid structures, or are filled with a coagulable fluid.

The rod-like bodies which Greef took for crystals, are almost certainly Bacteria; in a *Pelomyxa* killed with osmic acid, stained in bulk with eosin-alum, and teased up in glycerin, it was found that the rods were not constricted, but very distinctly jointed; the rods were always straight, and had two to nine joints; their refractive index seemed to be nearly the same as that of Canada balsam. Mr. M. D. Hill has attempted, but without success, to get a pure cultivation of these bodies.

**Nuclear Division in Noctiluca.\***—Dr. C. Ishikawa describes the peculiar phenomena of nuclear division in the budding of *Noctiluca miliaris*. As all previous observers have described, the living nucleus appears clear and homogeneous; but reagents display numerous granules in about ten straight or curved strands, which look like, and probably are chromosomes. In the budding there is a centrosoma which divides and is associated with archoplasm. Longitudinal cleavage of the chromosomes was clearly seen. There was no evidence of the nuclear origin of the archoplasm, indeed the nuclear membrane remained very distinct. The connecting threads between the separating nuclear segments appear to arise from the linin-threads of the nucleus, and have nothing to do with the cytoplasm.

**Enclosure of Globigerina by Orbulina.†**—Dr. L. Rhumbler discusses this strange occurrence about which much has been said. An original *Globigerina* shell, grown to a certain size, becomes surrounded by an *Orbulina* shell, and seems thus to be protected against the violence of the waves. The thick-walled stronger forms are not enclosed. The author shows that the *Globigerina* cannot have had its origin within the *Orbulina*, and dismisses some other interpretations. He has convinced himself that the thin-walled specimens of *Globigerina bulloides* d'Orbigny are the young stages of *Orbulina universa*, and believes that *Orbulina universa* makes in its youth 12-14 chambers of the *Globigerina* type

\* Ber. Nat. Ges. Freiburg, viii. (1894) pp. 54-69 (1 pl.).

† Zool. Anzeig., xvii. (1894) pp. 196-202.

before the enclosing *Orbulina* shell is formed. Various stages in the absorption of the enclosed *Globigerina* shell are described.

**Classification of Myxosporidia.\***—Mr. R. R. Gurley has a preliminary notice of a new classification of these spore-bearing forms. He suggests the use of pansporoblast for the plasma-sphere from which the sporoblasts arise; sporoplasm for the protoplasm of the spore; capsulated index for the ratio of the length of the capsule to the antero-posterior diameter of the shell-cavity; pericornual nuclei for the two nuclei ("granules" or "globules") at the antero-lateral angles of the sporoplasm, or on the posterior extremities of the capsule.

The author's classification is based on the symmetry of the spores as the most important taxonomic criterion; two orders with five families are recognized. The arrangement is as follows:—

Subclass Myxosporidia; pansporoblast produces—

- I. Many (at least 8) minute spores, lacking distinct symmetry and possessing but one capsule . . . Order, Cryptocytes
  - A. Spores numerous, inconstant; pansporoblast membrane
    - a. Not subpersistent; a myxosporidium . . . . . *Glugea*
    - b. Subpersistent; no myxosporidium . . . . . *Pleistophora* g. n.
  - B. Spores constant (8); pansporoblast membrane subpersistent, no myxosporidium . . . . . *Thelohania*
- II. Few (7 at most) rather large spores, with distinct symmetry and two or more capsules . . . . . Order, Phænocytes
  - Spores symmetrical bilaterally; antero-posterior symmetry
    - A. Present . . . . . *Cystodiscus*
    - B. Absent; capsule on
      - a. Two groups, right and left wings; not bivalve . . . . . *Myxidium*
      - b. One group, at anterior end; bivalve; capsules
        - α. Four . . . . . *Chloromyxum*
        - β. Two; inclination of plane of junction of valves to longitudinal plane
          - i. 0°; a vacuole . . . . . *Myxobolus*
          - ii. 90°; no vacuole; sporoplasm unilateral . . . . . *Ceratomyxa*

**Spores of Microsporidia.†**—M. P. Thélohan has found that the spores of a certain number of Myxosporidia have a striking resemblance to those of the Microsporidia. This discovery led him to see whether the spores of the latter contained, like the former, a capsule with a filament. This he has succeeded in observing. One of the difficulties in the way is due to the very small size of these spores, and the extreme tenuity of the filament. The best way to demonstrate them is, after treatment with nitric acid, to allow of the entrance of a few bubbles of air under the cover-glass. As the spore of the Microsporidia has altogether the same constitution as that of the Glugeidæ among the Myxosporidia, those organisms ought to be considered as belonging to this last group.

\* Bull. U.S. Fish Comm., 1891 (1893) pp. 407-20. See Amer. Natural., xxviii. (1894) pp. 404-6. † Comptes Rendus, cxviii. (1894) pp. 1425-7.

**New Genus of Gregarines.\***—M. L. Léger describes a new genus of the Dactylophoridae, which he calls *Rhopalonia*. The specific name *Geophili* refers to its presence as a parasite in Geophilidae, the only group of Chilopoda in which Gregarines have not till now been found. The parasite is found in the digestive tube, and is half a millimetre long. Unlike other Dactylophoridae, this new form has one, and not two segments, but its history is the same as that of the four already known genera, which are confined to Myriopods, and appear to form a very homogeneous family.

**Structure of Nucleus of Crescentiform Bodies of Malaria.†**—Dr. Sakharoff stained the blood of callow ravens taken from nests in malaria districts with Romanowski's mixture of eosin and methylen-blue. The nuclei of the plasmodia were clearly stained, and the staining showed that they were composed of fibrillae which not unfrequently presented karyokinetic figures. The flagellate bodies by this method of staining appeared like parasites the nuclei of which had split up into chromatin filaments. The author infers that the formation of flagellate bodies depends on a karyokinetic fission process disturbed by the influence of cooling. With the blood of men sick of malaria in which crescentiform bodies were to be found, the author obtained the same results as he did when he procured blood from malaria patients by means of leeches and allowed it to dry for half an hour after removal.

\* Comptes Rendus, cxviii. (1894) pp. 1285-8.

† Protokolle d. Kaukasischen Med. Gesellsch., 1893-4, Nos. 7 and 12. See Centralbl. f. Bakteriol. u. Parasitenk., xv. (1894) p. 962.





## BOTANY.

A. GENERAL, including the Anatomy and Physiology  
of the Phanerogamia.

## a. Anatomy.

## (1) Cell-structure and Protoplasm.

**Independence of the Nucleus and the Cytoplasm.\***—From experiments made on the staminal hairs of *Tradescantia virginica* and on animal leucocytes, Dr. J. Demoor argues that the functions of the nucleus and of the protoplasm (cytoplasm) are independent of one another. Mitosis can proceed in a cell where the protoplasm has become immobile, the nucleus continuing to manifest an activity after the cytoplasm has ceased to be active. It is possible for the nucleus to carry on an anaerobic existence. The formation of a new cell-wall in the process of cell-division requires the intervention of the cytoplasm.

**Karyokinesis.†**—Mr. L. B. Elliott recommends, as affording good examples of the karyokinetic figures in the division of the nucleus, the young cells of the terminal pinnæ and of the sporanges in *Botrychium virginianum*.

**Structure of the Cell-wall.‡**—Referring to his previous observations on the presence of pectic substances in the cell-wall, M. L. Mangin criticizes in several respects the statements of Gilson,§ especially his description of the median lamella of the cell-wall as being of an unknown chemical composition, whereas the author has shown that it is composed of insoluble pectates. He also objects to the use of the term hemi-cellulose, because it implies, for the substances included in it, a relationship with cellulose which has not been established; and also because the definition of it given by Gilson would include all the reserve carbohydrates of the cell-wall.

**Growth of the Cell-wall.||**—Dr. A. Zimmermann adduces arguments in contravention of the theory of Wortmann,¶ that the growth of the cell-wall takes place mainly by tension and by apposition, and in favour of the view that intussusception plays an important part in the phenomenon. The displacement of the molecules of cell-wall which takes place during its growth must be largely the result of turgidity.

**Development of Elaioplasts in the Liliaceæ.\*\***—M. M. Raciborski recommends for the demonstration of these structures the use of a dilute tincture of alkanna in 1 per cent. acetic or formic acid. In from one to five minutes the elaioplasts are stained a beautiful red, while the dilute

\* Bull. Soc. Belge Microscopie, xx. (1894) pp. 36-40.

† Bull. Lab. Nat. Hist. State Univ. Iowa, ii. (1893) pp. 175-7.

‡ Bull. Soc. Bot. France, xl. (1894) pp. 273-80. Cf. this Journal, *ante*, p. 75.

§ Cf. this Journal, *ante*, p. 215.

|| Beitr. z. Morph. u. Phys. d. Pflanzenzelle (Zimmermann), i. (1893) pp. 159-84.

¶ Cf. this Journal, 1889, p. 548.

\*\* Anz. Akad. Wiss. Krakau, 1893, pp. 259-71. See Bot. Centralbl., lvii. (1894) p. 305. Cf. this Journal, *ante*, p. 76.

acid fixes the protoplasmic stroma and the other protoplasmic contents of the cell. The sections may then be secondarily stained by iodine-green or iodine-green and fuchsin.

Of seven species of *Ornithogalum* examined, all were found to contain elaioplasts. In *O. umbellatum* they appear in the spring within the epidermal cells of the ovary, as small strongly refringent globules, always lying at one pole of the elongated nucleus. They take no part in the division of the nucleus, and multiply by new formation out of the cytoplasm. At the time of flowering they have a granular structure, and contain numerous cavities; finally they assume a mulberry-like form. In *O. stachyoides* their multiplication has a strong resemblance to budding. Similar results were obtained from *Albuca altissima* and species of *Funkia*. In all the species of *Gagea* examined the elaioplasts were distinguished by a feeble development of the stroma.

The chemical reactions show that the elaioplasts are identical with the so-called oil-drops of the chromatophores; their stroma gives proteinaceous reactions. They are also morphologically interchangeable with the oil-structures of the Hepaticæ, the resin- and oil-globules of grasses, with those vacuoles the tonoplast of which does not produce oily substances, and with tannin-vesicles.

**Proteinaceous Crystalloids.\***—Dr. A. Zimmermann gives the results of a series of observations on crystalloids of a proteinaceous character found in the nucleus, in the chromatophores, and in the cytoplasm or cell-sap. Within the nucleus they are very much more common than has hitherto been supposed, and vary greatly in size and form. A list is given of the species in which they were detected. They are especially frequent in the Scrophulariaceæ and Oleaceæ; while they have not yet been detected in the Labiatae. They occur in the most various organs, and their presence or absence appears to have no relation to the mode of life of the species. Within the chromatophores crystalloids occur also in the most widely separated families. Only in a few plants were they detected outside the protoplasts.

#### (2) Other Cell-contents (including Secretions).

**Localization of Fatty Oils in the Formation of Seeds and Fruits.†**—In accordance with previous observations on the localization of fatty oils in the germination of seeds, M. E. Mesnard finds that, where these substances occur in seeds and fruits, they are distributed through all the cells. Wherever albuminoid substances are present as reserve-materials in the endosperm, they are accompanied by fatty oils; but the oil may frequently occur without any accompanying albuminoid. The oils are apparently formed out of the chlorophyllaceous protoplasm of the stems and leaves.

**Active Principles of the Papayaceæ.‡**—In the species of Papayaceæ examined (*Carica Papaya*, *C. condinamarcensis*, *Vasconcellea quercifolia*), M. L. Guignard finds—in harmony with the facts observed in the

\* Beitr. z. Morph. u. Phys. d. Pflanzenzelle (Zimmermann), i. (1893) pp. 112-58 (2 pls. and 2 figs.). Cf. this Journal, 1891, p. 362.

† Bull. Soc. Bot. France, xli. (1894) pp. 114-20. Cf. this Journal, 1893, p. 346.

‡ Journ. de Bot. (Morot), viii. (1894) pp. 67-79, 85-92; and Comptes Rendus, cxviii. (1894) pp. 545-7. Cf. this Journal, *ante*, p. 218.

Crucifere and allied orders—a soluble ferment possessing the properties of myrosin, and a glucoside analogous to potassium myronate. These principles are present in the largest quantity in the root; but occur also in the stem and other vegetative organs of *C. Papaya*. They have nothing to do with the papaine and carpaine which have also been extracted from these plants. The properties of the seeds resemble those of the Capparideæ; the myrosin is found only in the embryo; the ferment only in the endosperm.

Indican.\*—Prof. H. Molisch finds indican in about ten genera of plants belonging to several natural orders,—*Isatis*, *Polygonum*, *Phajus*, *Calantha*, *Marsdenia*, *Indigofera*, &c. It may be detected by exposing the part of the living plant which contains it, usually the root, to the action of vapour of alcohol; the chlorophyll is then extracted by absolute alcohol, and the indican transformed into indigo-blue by the action of concentrated chloral hydrate. Indigo-blue never occurs in the living cell.

In the rhizome of *Lathræa squamaria* he finds a colourless chromogen, yielding, with dilute hydrochloric acid, a blue pigment which is certainly not identical with indigo.

Pigment of the Aril.†—Ritter Schrötter v. Kristelli has investigated the nature of the pigment contained in the aril of *Afzelia Cuanzensis* (Leguminosæ) and *Ravenala madagascariensis* (Musacæ), and finds it (in the first-named plant) to be a lipochrome identical with carotin, combined with a fatty oil. The pigment of the aril of *Ravenala* is of a totally different character, and differs in some respects from any hitherto found in the vegetable kingdom, though presenting some analogies with indican. The structure of the seed, of the aril, and of the funicle, is described in detail in each case.

Nitrates in Living Plants.‡—M. Demoussy explains the absence of nitrates from dead roots and from withered leaves, by the fact that in living tissues their extreme solubility is counteracted by their entering into a very close mechanical association with protoplasm. When released from this they are again readily dissolved out by water.

### (3) Structure of Tissues.

Connection between Lignification, Firmness, and Elasticity in Cell-walls.§—From experiments made on a number of woody plants, Herr P. Soumtag derives the law that there is an inverse relationship between lignification and increase in diameter. Tissues which consist of cells that are but little or not at all lignified offer a much greater resistance to traction than those which are greatly lignified. The degree of elasticity stands in an inverse, that of extensibility in a direct, relation to lignification.

Increase in Thickness of the Stem of Monocotyledons.||—From an examination of the stem of about thirty species of Monocotyledons,

\* SB. K. Akad. Wiss. Wien, cii. (1893) pp. 269-90.

† Tom. cit., pp. 381-421 (2 pls.).

‡ Comptes Rendus, cxviii. (1894) pp. 79-82.

§ Landwirthsch. Jahrb., 1892, pp. 839-69. See Biol. Centralbl., xiv. (1894) p. 138.

|| Bot. Tidsskr., xviii. (1893) pp. 112-26 (12 figs.). See Bot. Centralbl., lviii. (1894) p. 388.

Herr O. G. Petersen has come to the conclusion that the ordinary conception that the increase is effected by means of a special meristem only in the case of the arborescent Liliaceæ is incorrect. There is, on the contrary, a gradual passage from the type of *Dracæna* to that of the Orchideæ, where there is a complete absence of meristem. This latter is the case in the stem of *Vanilla Pompona* and *Vanda tricolor*, in the green aerial tubers of species of *Epidendron*, and in the thick rhizome of *Typha*. From an anatomical point of view the author distinguishes, in the stem of Monocotyledons, the cortex and the central cylinder, the latter being again composed of the pericycle (when present), the bundle-layer, and the pith.

**Palisade-cells and Transpiration.\***—M. P. Lesage adduces arguments in favour of the view that the palisade-tissue of leaves is an apparatus for protecting the plant from excessive transpiration. These are derived from the following facts:—Palisade-cells attain a fuller development in the light than in the shade, and in dry than in moist air. In submerged leaves they are entirely wanting. In Alpine plants, and in plants growing in a salt soil, the palisade-tissue is especially strongly developed.

**Medullary Rays of Dicotyledonous Herbs and Shrubs.†**—Herr A. Herbst has made a study of the structure of the medullary rays in herbaceous and shrubby plants belonging to a great number of different natural orders of Dicotyledons. Several points are, he says, of considerable use for purposes of classification, especially the number of rows of cells of which the rays are composed. Although the thickening of the wall of these cells is usually only slight, yet there are considerable variations in this respect. The medullary rays consist either of so-called "palisade-cells" only, or of "mesenchyme-cells" only, or of both kinds, but this character can be used only in the determination of species. Both in the summer and in the late autumn there is in the medullary rays an abundant intercellular system. This may often run through the whole of the ray and through the cambium as far as the bark, and communicate with the external air through stomates or lenticels.

The author confirms the hypothesis of Russow, that the bordered pits of the medullary rays serve for the conveyance not only of water, but also of air. The imperfectly bordered pits on the sides of the cells which face intercellular spaces appear to indicate that the latter are of schizogenous origin.

**Witch-broom of the Fir.‡**—M. E. Mer describes in detail the structure of the excrescence (*chaudron*) from which grows the tuft of fasciated branches known as "witch-broom," caused by the attacks of a parasitic fungus, *Æcidium elatinum*. While the cortex and liber of the trunk acquire a hypertrophied development, those of the vascular bundles are partially suppressed. The cambium, which is at first excited to an increased activity, finally perishes. The ultimate result is always the death of the tree.

\* Comptes Rendus, cxviii. (1894) pp. 255-8.

† Bot. Centralbl., lvii. (1894) pp. 257-66, 289-98, 321-30, 353-61, 401-13 (1 pl.).  
Rev. Gén. de Bot. (Bonnier), vi. (1894) pp. 153-73.



**Cystoliths of Coccinia.\***—Sig. C. Avetta describes the cystoliths found in the leaves of some species of this genus of Cucurbitaceæ. Unlike those of *Momordica*, they occur only in the epiderm of the upper surface. When mature they completely fill up the cavities of their mother-cells; they are inserted, not on the outer wall of the epidermal cells, but at the edges of the cells which form the centre of each group.

**Anatomy of Rubiaceæ.†**—Herr H. Solereder describes in detail the anatomical structure of this order, and makes several suggestions with regard to the systematic position of the genera. The most invariable characters are the presence of two or more auxiliary cells accompanying the guard-cells of the stomates; the absence of glandular hairs on the leaves; and the invariably simple collateral vascular bundle in the axis. In *Pavetta* and *Strumpfia*, crystals arise in the cells of the pith, liber, and primary cortex of the stem, which become surrounded by a wall of cellulose, and finally constitute a peculiar sclerenchymatous tissue. Cystoliths were not detected in any species of Rubiaceæ.

#### “(4) Structure of Organs.

**Variety and Localisation of Organs as Evidence of Gradation.‡**—According to M. A. Chatin, a variety or multiplicity of organs, as contrasted with a multiplicity of homologous parts, is a sign of elevation of structure. Various degrees of degradation are exhibited by parasites, by aquatic plants, and by those in which one of the floral envelopes is suppressed. The presence of endosperm in the seed is evidence, not of high, but of low organization, since it indicates an arrest of development, those processes being delayed till after germination which, in exalbuminous seeds, are completed before germination.

Dicotyledons exhibit, in many points, a greater differentiation of organs than Monocotyledons, and are, therefore, higher in the scale. Thus the primary root of Monocotyledons is generally arrested in its development; and this is still further the case in Vascular Cryptogams; the stem of Monocotyledons is much less branched, and has no strongly differentiated pith, pericycle, or endoderm; the leaves are not usually stalked. The author places the Gamopetalæ with superior ovary at the head of the various divisions of the vegetable kingdom.

Hermaphroditism must, by the same law, be treated as a higher type of structure than unisexuality; and this occurs most universally in the Gamopetalæ with superior ovary.

**Young Form of Gymnosperms.§**—Dr. H. Schenck notes that, in many Coniferæ and some Cycadææ, the young plant differs in biological characters from the mature plant. In the larch this is especially shown in the fact that, during the first four years at least, a portion of the

\* Ann. R. Ist. Bot. Roma, v. pp. 181-4. See Morot's Journ. de Bot., 1893, Rev. Bibl., p. ci.

† Bull. Herb. Boissier, i. (1893) pp. 167-83, 268-86, 308-26. See Bot. Centralbl., 1894, Beih., p. 26.

‡ Comptes Rendus, cxvii. (1893) pp. 604-7; cxviii. (1894) pp. 773-7; and Bull. Soc. Bot. France, xl. (1893) pp. 328-30; xli. (1894) pp. 217-23. Cf. this Journal, 1893, p. 754.

§ SB. Niederrhein. Gesell. Naturk. u. Heilk. Bonn, l. (1893) pp. 27-38 (5 figs.).

leaves remain through the winter. A number of Cupressineæ, the mature leaves of which are scale-like and adpressed, have, when young, typical needle-like leaves.

**Inflorescence of Urticaceæ and Moraceæ,\***—Herr M. Golenkin has investigated the structure and development of the inflorescence in a large number of genera belonging to these two natural orders. He classes the various forms under two types. The first is dichasial, which may be simple (*Parietaria*, *Pellonia*, *Memorialis*, and some species of *Urtica*); or a number of dichasial inflorescences may be combined on branched dorsiventral axes (*Laportea*, *Fleurya*, *Girardinia*, *Bœhmeria*); or the inflorescences may be borne on shoots covered with bracts (*Cannabis Humulus*). The second and much less common type is that which occurs in *Ficus* and *Dorstenia*, and is not dichasial, but is characterized by the tissue of the receptacle retaining for a long period its meristematic character.

**Structure of the Flower of Cruciferæ.†**—From observations made on the genera *Matthiola* and *Cheiranthus*, Herr J. Klein maintains the view that the suppression of two of the shorter stamens which constitute the outer whorl is due to the presence of the honey-glands; and that two out of the originally four carpels have become suppressed in the course of development, and constitute the septum or replum.

**Development of the Flowers of Crocus.‡**—Herr K. Schumann distinguishes between two different kinds of apparently terminal flowers, *euacranthic* and *pseudacranthic*. The former spring immediately from the apex of a shoot which has produced leaves or other lateral structures, and there is no contact with any supporting axis or leaf; while the latter term is applied to the apparently terminal flowers of dichasial shoots. True terminal (euacranthic) flowers blossom earlier than the lateral, and have a tendency to differ from them in the number of members of each floral whorl.

In all the species of *Crocus* examined either the solitary flower or the central one is euacranthic. The rudiments of both spring and autumn flowers make their appearance in the latter half of July.

**Cladodes of the Asparagæ.§**—Dr. L. Celakovsky discusses the nature of the cladodes in the Asparagæ (*Danae racemosa*, *Semele androgyna*, *Ruscus aculeatus*, *R. hypoglossum*, *R. hypophyllum*, *Myrsiphyllum asparagoides*, *Asparagus officinalis*), and decides beyond question on their being caulomic in character—branches, in fact, which have assumed the form and appearance of leaves.

**Size of the Leaves of Conifers.||**—According to Herr R. Meissner the leaves of conifers vary in size from year to year; but, on the same tree, are, as a rule, larger, the higher the order of the branch on which they grow. No increase in length could be detected after the first year in those which live for several years, but a very slight increase in thick-

\* Flora, lxxviii. (1894) pp. 97-132 (4 pls. and 1 fig.).

† Ber. Deutsch. Bot. Gesell., xii. (1894) pp. 18-24 (1 pl.).

‡ Bot. Ztg., lii. (1894) 1<sup>o</sup> Abtheil., pp. 29-54 (1 pl.).

§ Czech. Franz Josephs Akad. Prag, 1893, 66 pp. and 4 pls. See Bot. Centralbl., lvii. (1894) p. 279.

|| Bot. Ztg., lii. (1894) 1<sup>o</sup> Abtheil., pp. 55-82 (1 pl.).

ness, this being chiefly due to an increase in the elements of the sieve-portion of the vascular bundles.

**Swellings on the Leaf-stalk of *Atragene*.**\*—Herr W. Tonkoff describes the structure of the swellings which are found on the concave side of the leaf-stalk of *Atragene alpina*, at the spots where it curves in consequence of contact with a support. They differ from similar swellings on the tendrils of *Ampelopsis* in being rich in chlorophyll, in the cell-walls being thickened and lignified, and in their not forming a viscid exudation.

**Aerial Roots of Orchideæ.**†—Herr E. P. Meinecke has examined the structure of the aerial roots in a large number of genera of Orchideæ belonging to a number of different tribes.

The velamen is composed of a very variable number of layers of cells; their walls are almost always strongly thickened; the most common form of thickening is spiral, though the pitted and reticulate also occur; the wall which bounds the endoderm is usually furnished with peculiar ridges; and these are in places provided with the characteristic rod-like bodies. The endoderm forms a cylinder composed alternately of longer and shorter cells, the former having thicker walls than the latter. The development of the cortical parenchyme varies greatly; its walls are usually very strongly thickened, and its mucilage is usually infested with fungus-hyphæ, which penetrate also to the smaller endoderm-cells. The projecting sheath and the pericambium each consists of a single layer of cells. The degree of lignification of the vascular bundles is very variable.

As a general rule the variations in the anatomical structure of the aerial roots correspond with the accepted limitations of the various tribes of Orchideæ.

**Root of Parasitic Lorantheæ.**‡—According to M. P. Van Tieghem, the root of some parasitic Lorantheæ presents two remarkable peculiarities not found elsewhere in the root,—the entire absence, in the cortex, of a framework to the endoderm, and the presence, in the stele, of fibrous pericyclic bundles outside the phloem-bundles. The greater number of parasitic Lorantheæ are entirely destitute of roots; but in others adventitious roots of endogenous origin are produced either at the base of the stem only, or along the internodes, or at the nodes. The peculiar structure described was found in the lateral aerial roots of species belonging to six genera, *Macrosolen*, *Oryctanthus*, *Loranthus*, *Phrygilanthus*, *Phthirusa*, and *Struthanthus*. Similar modifications of the primary structure have long been known in the stem and leaf.

### B. Physiology.

#### (1) Reproduction and Embryology.

**Chromatophily of the Nuclei of the Embryo-sac.**§—From an examination of the embryo-sac of a number of plants (chiefly Monocotyledons) M. M. Raciborski states that in all the Angiosperms examined,

\* Ber. Deutsch. Bot. Gesell., xii. (1894) pp. 40-8 (1 pl.).

† Flora, lxxviii. (1894) pp. 133-203 (2 pls.).

‡ Bull. Soc. Bot. France, xli. (1894) pp. 121-7.

§ Anzeig. Akad. Wiss. Krakau, 1893. See Bot. Centralbl., 1894, Beih., p. 24.

the nuclei of the antipodals differ in their chromatophily from the other nuclei of the embryo-sac. Among Gymnosperms there is, in *Biota*, no difference in the size, structure, or chromatophily of the male nuclei, while they are still in the pollen-tube before impregnation. In Angiosperms the male nucleus of the pollen-tube becomes, in contrast to the vegetative nucleus, cyanophilous at the moment of impregnation. The nuclei of the antipodals contain also a larger number of chromosomes than the synergids or the oosphere. The erythrophily of the endosperm-nuclei disappears slowly on further segmentation.

The author is disposed to attribute the difference in the chromatophily of the pollen-nuclei to differences in their nutrition; the erythrophilous nuclei containing a larger quantity of the (erythrophilous) nucleohyaloplasm than the cyanophilous nuclei. He also lays stress on the differences in the morphological structure of the two kinds of nucleus, especially in that of their framework.

**Physiology of Pollen.\***—Prof. H. Molisch states that the pollen-grains of many plants (Compositæ, Umbelliferae, Malvaceae, Urticaceae) will germinate only in contact with the stigma; others will germinate in pure water; others again in a solution of sugar, the concentration of which may be as high as 40–50 per cent. The pollen-grains of Ericaceae will not germinate in pure water, nor in a solution of sugar; but they will in a 0·01 per cent. solution of malic acid, or in a 0·05–1·0 per cent. solution of calcium malate. The power of germination is retained, in different species, for a period varying from 12 to 72 days.

The pollen-tube is either negatively aerotropic or indifferent to oxygen in the culture-fluid, never positively aerotropic. It is positively chemotropic to the secretion of its own stigma, and sometimes to that of the stigma of another species, even if not nearly related. This chemotropism must often have an important influence in directing the pollen-tube to the oosphere.

The pollen-grain frequently contains starch. In most Compositæ and in some other plants the membrane of the pollen-grain is partially composed of a substance which is coloured red-violet by concentrated sulphuric acid.

**Fertilization of Pinus.†**—Mr. H. H. Dixon reviews the results arrived at by Strasburger, Belajeff, and Overton, with regard to the impregnation of Gymnosperms. In the ripe pollen-grain of *Pinus sylvestris* there is a small prothallium-cell and a large nucleus, which is the nucleus of the pollen-tube, and passes into the tube which is formed immediately after pollination. The prothallium-cell remains attached to the wall of the pollen-grain; and in this condition the pollen remains during the winter. The pollen-tube reaches the nucellus about thirteen months before fertilization takes place.

Next spring the pollen-tube becomes filled with starch, and the prothallium divides to form a small pedicel-cell and a larger body-cell; this latter then breaks away from the pedicel-cell and divides into two cells, which are the male sexual cells. These two male cells then move slowly down into the pollen-tube, closely followed by the nucleus of the

\* SB. K. Akad. Wiss. Wien, cii. (1893) pp. 423–48 (1 pl.).

† Ann. Bot., viii. (1894) pp. 21–34 (3 pls.). Cf. this Journal, 1893, p. 756.



pedicel-cell, which ultimately overtakes them; all three eventually approach close to the nucleus of the pollen-tube. The growth of the pollen-tube is now extremely slow; it eventually penetrates the nucellus, exercising a destructive influence on the cells in its immediate neighbourhood, which lose their nuclei and become filled with a brown substance. At this period the pollen-tube sometimes branches, but ultimately only one branch is continued; its growth being now very much more rapid. When the pollen-tube reaches the oosphere, not only the two sexual, but also the two non-sexual nuclei pass into it; but only one of the male nuclei unites with the female nucleus, the other remaining in the protoplasm of the oosphere.

With regard to the number of chromosomes in the gametophyte,\* the nuclei of the prothallium or endosperm contain 8, the nuclei of the walls of the archegone 8, 12, or 24, and the nuclei of the oosphere and of the ventral canal-cell each probably 8. After the first division of the oosperm 16 chromosomes were found. The nuclei of the primary meristem of the growing-point contain 16.

**Hybridism in Cucurbitaceæ.**†—According to experiments made by Mr. L. H. Pammel on a great variety of cucumbers, gourds, and pumpkins, fertilization takes place only within the limits of the same species, not with different species. Where the flowers are hermaphrodite, they are not self-fertile. Well-marked cases of prepotency occur in the order.

**Pollination of *Strelitzia*.**‡—Herr A. Wagner ascribes the peculiarities of the flowers of *Strelitzia reginæ* to its ornithophilous mode of pollination, it being visited largely by humming-birds. They consist in the union of two of the petals into a winged spear-shaped structure, forming a firm sheath, within which the five anthers are concealed; and in the union of the pollen-grains with one another by means of cellular filaments. The peculiar structure of the stigma is described in detail.

(2) Nutrition and Growth (including Germination, and Movements of Fluids).

**Influence of the Chemical Intensity of Light on the Growth of Plants.**§—According to observations made by Prof. J. Wiesner, the rate of growth of the stem is, as a general rule, in inverse proportion to the chemical intensity of the light, attaining a maximum in absolute darkness; while that of the leaves increases to a certain limit with the increase in the chemical intensity of the light, and then falls when the intensity is further increased. But there are exceptions to these rules. In evergreen trees and shrubs, the buds must be located in the periphery of the mass of foliage, in order to obtain sufficient light for their development; while in deciduous trees they are found also in the centre of the foliage. The normal habit of "sun-plants" disappears under a relatively high chemical intensity of the light; thus the leaves of *Sempervivum tectorum* become etiolated under these conditions. The size

\* Cf. this Journal, 1893, p. 495.

† Bull. Iowa Agric. Exp. Stat., 1893, pp. 906-17 (1 pl. and 2 figs.).

‡ Ber. Deutsch. Bot. Gesell., xii. (1894) pp. 53-72 (1 pl. and 5 figs.). Cf. this Journal, 1890, p. 628, and 1891, p. 621.

§ SB. K. Akad. Wiss. Wien, cii. (1893) pp. 291-350.

of leaves is dependent, on the one hand, on the degree of moisture of the air, on the other hand on the chemical intensity of the light.

Very sensitive parts of plants (*Amaranthus melancholicus*) exhibit heliotropism when exposed to light amounting only to a fraction of a millionth of Bunsen and Roscoe's unity of intensity; in the case of etiolated stems of *Vicia sativa* to only a ten-millionth. Heliotropic organs may either suspend their growth entirely in the dark, as the hypocotyl of *Viscum album*, or their growth may be promoted, as in the case of ordinary positively heliotropic organs, or retarded, as the cotyledons of *Pinus sylvestris*, or the intensity of growth may be nearly the same in the dark as in the light, as the cotyledons of *Abies excelsa*.

**Influence of Phosphorus on the Growth of Plants.\***—By a series of experiments on *Tradescantia Selloi*, Dr. F. Noll claims to have determined that phosphorus is of great importance to the growth of plants, not only for the seeds but also for the formation of the vegetative organs.

**Morphology and Physiology of Grafting.†**—As the result of a series of experiments on the grafting of annual, biennial, and perennial plants, M. L. Daniel states that grafting often succeeds between genera belonging to different sub-tribes, or even to different tribes of the same family. In herbaceous plants, root-grafting is especially successful. Annual or biennial, grafted on perennial plants, remain respectively annual or biennial. The host and the graft exercise a reciprocal influence on one another; but if seeds from a root-graft germinate the seedlings display a return to the original properties of the grafted species.

Reserve-materials accumulated in a root-host before grafting are rarely used by the graft, unless it belongs to the same family as the host. When the graft is first made, the passage of the crude sap from the host is effected only with great difficulty. The absorption of water is reduced without any decrease in the transpiration. The passage of sugar, starch, and other substances between the host and the graft is subject to different laws in different cases.

**Germination of Seeds.**—The late G. J. Romanes‡ carried out a series of experiments for the purpose of determining the extent to which the power of germination of dry seeds is affected by preventing their respiration for long periods. To this end they were sealed in vacuum-tubes of high exhaustion (one-millionth of an atmosphere) for three months, and then transferred, for a period of twelve months, to other tubes containing pure gases or vapours (carbon dioxide, nitrogen, chloroform, &c.). In no case was their power of germination deteriorated to any considerable extent.

M. R. Pictet§ states that many seeds may be exposed, when dry, to a temperature of  $-200^{\circ}$ , without in the least injuring their vital activity. Similar results were obtained with various bacteria.

According to M. C. Chauveaud,|| the germination of grape-seeds can

\* Naturwiss. Wochenschr., viii. (1893). See Biol. Centralbl., xiv. (1894) p. 258.

† Rev. Gen. de Bot. (Bonnier), vi. (1894) pp. 5-21, 60-75 (2 pls.). Cf. this Journal, 1893, p. 211.

‡ Proc. Roy. Soc., liv. (1894) pp. 325-7.

§ Arch. Sci. Phys. et Nat., xxx. (1893) pp. 293-314.

|| Comptes Rendus, cxviii. (1894) pp. 211-2.

be greatly accelerated by removing the hard integument of the beak. This is the result partly of allowing free entrance of water to the embryo, partly of the removal of the mechanical obstacle to the emergence of the radicle.

Mr. H. H. Dixon \* has proved by experiment the incorrectness of the assertion that the presence of bacteria is essential to the germination of seeds.

Herr C. Nesgenyi † has followed out the various stages in the germination of the seeds of the chicory, especially in reference to the chemical changes which take place, and to those which are brought about by the absence of light. Before the complete exhaustion of the reserve food-materials contained in the cotyledons, the parenchyme of these organs, and of the uppermost portion of the hypocotyl, is filled with nearly assimilated starch. If light is excluded, this starch is, in the etiolated hypocotyl, replaced by glucose. This, and the remains of the reserve-starch and proteids, are then rapidly consumed, and the plant dies.

**Pseudo-vivipary of *Juncus bufonius*.** ‡—Dr. H. Potonié calls attention to the fact that the so-called viviparous condition of this cosmopolitan plant is not an example of true vivipary, understanding by that term the production of deciduous shoots or buds in the place of flowers, as occurs in *Poa bulbosa* and *Allium vineale*. The "pseudo-vivipary" of the toad-rush consists in the production of leafy rooting shoots in the floral region by the side of the flowers.

**Etiolation.** §—Dr. E. Amelung records the result of a series of observations on the effect on the growth of *Cucurbita maxima* of shutting off the light from the growing part, while the lower portion remained under normal conditions. The first leaves formed in the dark, although etiolated, were of the normal size; but when a large number were formed in the dark, they became gradually smaller. The male flowers are much more unfavourably affected by darkness than the female. Female flowers formed in the light were sterile to the pollen of male flowers formed in the dark; while, on the other hand, female flowers formed in the dark could be impregnated by pollen from normal male flowers. No fertile seeds were formed in the dark.

**Symbiosis of *Heterodera radicola* with Plants cultivated in the Sahara.** ||—MM. P. Vuillemin and E. Legrain state that, while this roundworm is very destructive to the roots of cultivated plants growing in moist localities, it is actually advantageous to those growing in the desert. In the Sahara it attacks almost every cultivated crop, even those free from it in other situations, and causes the young vessels to swell into bladders with thin walls and numerous nuclei, which serve as reservoirs of water, and enable the plant to thrive in an excessively arid and sandy soil. No tubercles produced by bacilli were observed in the Leguminosæ under similar conditions.

\* Sci. Trans. R. Dublin Soc., v. (1893) pp. 1-4 (1 fig.).

† 'Beitr. z. Keimungsgesch. v. Cichorium Intybus,' Prag, 1893, 55 pp. and 2 pls. See Bot. Centralbl., 1894, Beih., p. 65.

‡ Biol. Centralbl., xiv. (1894) pp. 11-21 (1 fig.).

§ Flora, lxxviii. (1894) pp. 204-10. Cf. this Journal, ante, p. 371.

|| Comptes Rendus, cxviii. (1894) pp. 549-51.



**Symbiosis of Algæ and Bacteria with Cycas.\***—Mr. A. Schneider states that the roots of *Cycas revoluta* are constantly furnished with tubercle-like growths, the palisade-layer of which is commonly infested with a *Nostoc*. The alga is certainly not the cause of the development of the tubercle, and it appears not to be harmful to the host. Nearly all the cells of the tubercle also contain bacteria and rhizobes, among which were detected a coccus, and two rhizobes resembling *Rhizobium Frankii* and *R. mutabile*.

**Life-history of the Mistletoe.†**—According to M. C. Guérin, the slime of the mistletoe-berry serves no purpose in glueing the berry to the branch, its function being the absorption of water; propagation is effected almost entirely by insectivorous birds, and especially by the missel-thrush, on which it has a purgative effect. Freezing does not destroy the germinating power of the berries. The seeds germinate only in the light; the branches are at first negatively geotropic; but afterwards grow straight. The majority of the seeds contain more than one embryo. The author was able to make the mistletoe grow parasitically on itself, although this does not occur in nature. Even in winter the parasite, and especially the male plant, absorbs a considerable amount of moisture from the host. The structure of the bark of the host is an important condition in the germination of the mistletoe, and this may account for its comparative rarity on the pear.

**Assimilation of Nitrogen by Plants.**—A further series of experiments on this subject carried on by M. E. Bréal ‡ show that the soils of forests and natural prairies are highly charged with organic matter, forming a medium in which the nitric ferments cannot transform ammonia into nitrate, and the vegetation is obliged to assimilate nitrogen in the form of ammonia. Grass land, therefore, becomes rich in organic nitrogen, in consequence of the small amount of nitrification which takes place.

Further experiments by M. S. Winogradsky§ show that the absorption of free nitrogen by bacilli, which he has already demonstrated, is due to the contact of the gas which they give off in the fermenting process with nascent hydrogen within the living protoplasm; the result being that ammonia is formed.

According to Herr G. Liebscher|| experiments on peas, oats, buckwheat, and mustard establish that there is only a difference in degree between the nitrogen-fixing power of the Leguminosæ and that of other plants.

Experiments by Herr J. B. Lotsy¶ on black and white mustard showed that neither is able to live in the absence of combined nitrogen.

Prof. H. Marshall Ward\*\* gives a very useful summary of recent

\* Bot. Gazette, xix. (1894) pp. 25-32 (2 pls.).

† Bull. Soc. Linn. Normandie, vi. pp. 183-229. See Bot. Centralbl., 1894, Beih., p. 30.

‡ Ann. Agron., xix. pp. 274-93. See Journ. Chem. Soc., 1893, Abstr., p. 500. Cf. this Journal, 1893, p. 357.

§ Comptes Rendus, cxviii. (1894) pp. 353-5. Cf. this Journal, ante, p. 97.

|| Journ. Landw., xli. pp. 133-98. See Journ. Chem. Soc., 1894, Abstr., p. 201.

¶ Exp. Stat. Bull., 1894, No. 18. See Journ. Chem. Soc., 1894, Abstr., p. 205.

\*\* Nature, xlix. (1894) pp. 511-4.



investigations and ideas on the fixation of nitrogen by plants. He does not regard as conclusive Frank's evidence in favour of the theory that this is a general property of all green plants, believing that no positive conclusion can be drawn from the result of experiments on plants growing in the open air. He calls attention to the enormous practical importance of the subject to agriculture.

**Fixation of Free Nitrogen by the Leguminosæ.\***—Pursuing their investigations on this subject, Herren F. Nobbe and L. Hiltner confirm their previous statement that the assimilation of nitrogen by the plant is connected with the conversion of the bacteria into bacteroids; and they compare the processes in the nodules to those in insectivorous plants. Unchanged bacteria appear to be unable to fix the free nitrogen of the atmosphere, the absorption commencing only with the production of bacteroids. The bacteroids are formed by the division, without separation, of bacteria. In the first stage the rod divides in the middle; the two poles are coloured like the unchanged bacteria, the intermediate space remaining colourless; branches may ultimately be formed. Many leguminous plants, especially *Robinia*, yield a larger final gain of nitrogen when grown in a soil free from nitrogen than in one supplied with combined nitrogen, owing to the very large nodules produced.

### (3) Irritability.

**Irritability in Plants.†**—The explanation offered by Errera † of the bending of hyphæ of *Phycomyces* towards iron—that it is a case of positive hydrotropism—is criticized by Herr F. Elfving, who dissents from this conclusion on the ground that other bodies which eagerly absorb water, such as caustic potash and calcium sulphate, do not attract the hyphæ of *Phycomyces*. He regards the phenomenon as a case of radiation depending on the molecular state of the radiating body. This may be compared with the case of platinum which, in its ordinary condition, is inactive on *Phycomyces*, but, after exposure for a time to direct sunlight, will, without undergoing any apparent change, attract the filaments.

**Chemotropic Movements.§**—Dr. M. Miyoshi has carried out a series of experiments on the chemotropic movements of fungus-hyphæ and pollen-tubes. The fungi experimented on were chiefly species of *Mucor*, *Phycomyces*, *Penicillium*, *Aspergillus*, and *Saprolegnia*; also of *Botrytis* and *Uredo*. Certain chemical substances exercise either an attractive (positive) or a repulsive force (negative chemotropism) on the growing hyphæ, thus greatly assisting their entrance into living organisms. The substances which produce the greatest effect are salts of phosphoric acid and of ammonia; and next to them, extract of meat, peptone, asparagin, and grape-sugar. In contrast to the results with bacteria, nitrates and chlorides of potassium, sodium, and calcium produced no effect. The irritating property of a fluid does not depend on

\* Landwirth. Versuchs-Stat., xlii. pp. 459-78. See Journ. Chem. Soc., 1893, Abstr., p. 588.

† Öfers. Finsk. Vet. Soc. Förhandl., xxxvi. (1894). See Nature, xlix. (1894) p. 466.

‡ Cf. this Journal, 1893, p. 358.

§ Bot. Ztg., lii. (1894) 1<sup>te</sup> Abtheil., pp. 1-28 (1 pl.), and Flora, lxxviii. (1894) pp. 76-93.

its nutritive value for the organism attracted. The attraction will often be either positive or negative, according to the concentration of the fluid. The movements are not the result of either geotropism or heliotropism. The actual perforation of the living cell-wall was seen, under the influence of an attractive fluid within the cell.

Precisely the same phenomena were observed in the case of pollen-tubes; they could in the same way be made to enter the stomates of leaves or to perforate cell-walls. For them sugar is an especially good irritant; extract of meat, asparagin, peptone, and glycerin are neutral; ammonium phosphate and sodium malate more or less repulsive. Not only the stigma, but a portion also of the style, the ovary, and the ovule, excrete a fluid which is attractive to pollen-tubes. Pollen-tubes are more or less hydrotropic, and often negatively aerotropic. The fluid excreted by one species is, as a rule, attractive also to the pollen-tubes of other species.

**Heliotropism.\***—From experiments made chiefly on seedlings of *Sinapis nigra*, the late Mr. G. J. Romanes drew the conclusion that the heliotropic influence of electric sparks or flashes is greater than that of continuous illumination. Heliotropic curvature could be detected in vigorous seedlings within from 15 to 30 minutes, under the influence of bright sparks applied at as low a rate as 1 per minute.

**Heliotropic Sensitiveness.†**—From experiments made on a variety of seedlings Dr. W. Figdor concludes that, as a general rule, shade-plants are more sensitive to heliotropic influences than sun-plants. With *Lepidium sativum* and others the lower limit of heliotropic sensitiveness was not reached at a distance of 7 m. from the source of light; this is represented by less than 0.0003262 of a candle-power.

**Biology of Cuscuta.‡**—Mr. G. J. Peirce describes the phenomena connected with the parasitism and the twining of *Cuscuta*, the observations having been made chiefly on *C. Epilinum*, *europæa*, and *glomerata*. Before the haustoria are formed by means of which the parasite receives food from its host, the supply of food takes place through certain papillate epidermal cells, to which the author gives the name *pre-haustoria*. The seedlings exercise a distinct selective power with respect to the objects round which they twine. The penetration into the host of the haustorial cells is accomplished by means of chemical action.

The stems of *Cuscuta* have two distinct modes of twining. The first resembles that of ordinary climbers; it is always in the direction in which they nutate, and is comparatively loose. At other stages, which alternate regularly with these, they make short, close, much more nearly horizontal turns about a vertical support, embracing it closely, and bringing their concave surfaces into intimate contact with it. The former mode of coiling is entirely the result of circumnutation and geotropism; the latter of contact-irritation. Haustoria are ordinarily formed only upon the concave surfaces of the close coils, and are the result of irritation.

\* Proc. Roy. Soc., liv. (1894) pp. 333-5.

† SB. K. Akad. Wiss. Wien, cii. (1893) pp. 45-59.

‡ Ann. Bot., viii. (1894) pp. 53-118 (1 pl. and 1 fig.). Cf. this Journal, ante, p. 82.

## (4) Chemical Changes (including Respiration and Fermentation).

**Analogies between Fermentation and Solar Combustion.\***—Prof. E. Duclaux points out that certain analogies exist between the processes of fermentation and of solar combustion. Thus, for example, if glucose and lactose in alkaline solution be put in the sun, they are gradually burnt up, the products of their combustion being formic acid, alcohol, and carbonic acid; this is just what happens in alcoholic fermentation, though the quantity of alcohol produced is but small, barely 3 or 4 per cent. of the weight of sugar. In the earlier experiments the liquids were alkalinized with baryta or lime; but when these are replaced by potash or soda, lactic acid is formed instead of alcohol, and this may amount to 50 per cent. of the weight of sugar. Moreover, the acid formed is not the same, sometimes being lævolactic, sometimes dextrolactic, and sometimes inactive lactic acid.

In solar combustion this appears to depend on the particular rotatory property of the sugar used. It is also noted that saccharose, so long as it is not inverted, resists solar combustion just as it does the action of ferments.

## γ. General.

**Archenema, Protonema, and Metanema.†**—Prof. C. Macmillan proposes to limit the term “gametophyte” to any structure derived directly or indirectly from a sporophytic spore or its analogue, and itself capable of producing, directly or indirectly, a gamete or gametes. Examples are afforded by *Cedogonium*, *Coleochæte*, leafy moss-plants, fern-prothallia, the endosperm of *Araucaria*, the pollen-tube of *Burmanna*, and the embryo-sac nuclei of *Narcissus*. The gametophyte of any species of Hepaticæ or of Mosses consists of two distinct developmental stages which may be termed respectively protonema and *metanema*. For gametophytic structures lower than the Hepaticæ, which do not show any differentiation into protonema and metanema, the author proposes the term *archenema*.

## B. CRYPTOGAMIA.

## Cryptogamia Vascularia.

**Classification of Ferns.‡**—The late Prof. K. Prantl proposed a new classification of the Pteridophyta—viz. a primary division of the Filicinæ into the two sections of Pteridales and Osmundales, depending on the mode of formation of the sporange. In the former division are included the Hymenophyllaceæ, Cyatheaceæ, and Polypodiaceæ; and the author considers that the Salviniaceæ and Marsileaceæ are also more nearly allied to them than are the Osmundales. In the latter family are included the Schizæaceæ, Gleicheniaceæ, Osmundaceæ, Ophioglossaceæ, and Marattiaceæ. The Polypodiaceæ are further divided into the Aspidicæ, Asplenicæ, Pterideæ, and Polypodieæ.

**Development of Marattia.§**—Prof. D. H. Campbell has followed out the early stages in the development of *Marattia Douglasii*. The spores

\* Ann. Inst. Pasteur, vii. (1893) pp. 751-4.

† Bot. Gazette, xix. (1894) pp. 19-24

‡ Arb. K. Bot. Garten Breslau, i. pp. 1-38. See Bot. Centralbl., lvii. (1894) p. 384.

§ Ann. Bot., viii. (1894) pp. 1-20 (2 pls.).

germinate readily, but the subsequent growth is very slow. The prothallium is distinguished by its very massive character; it is more than one cell thick, except at the edge, and has a strong mid-rib. It is remarkably persistent, remaining more than a year after the appearance of the young plant; and, if unfertilized, is apparently capable of unlimited growth and duration. The prothallia are monœcious, the antherids being found mostly on the lower surface of the mid-rib, but also on the upper surface of the prothallium; the archegones are formed later, and entirely on the lower surface of the mid-rib. The antherid arises from a single superficial cell, which first divides into an inner cell (the mother-cell of the antherozoid-cells) and an outer lid-cell. It would appear that any superficial cell of the apical meristem can develop into an archegone. In the early stages of the development of the embryo, *Marattia* agrees closely with *Angiopteris*. The first leaf is destitute of the stipules characteristic of the older plant.

The author regards these observations as confirming his previous views as to the primitive nature of the eusporangiate Pteridophytes, and as to their origin from the Bryophytes through the Anthocerotæ.

#### Muscineæ.

**New Genera of Hepaticæ.**—Under the name *Schiffneria hyalina* g. et sp. n., Herr F. Stephani \* describes a new genus of Jungermanniaceæ from the Moluccas, with the following diagnosis:—*Planta frondosa, radice fasciculatis repens; ramificatio postica, e latere costæ orta; frondes planæ, costatæ, alis attenuatis inciso-lobatis, lobi in plano falcati succube imbricati, folia fimbriata; amphigastria pro more nulla; cellulæ centrales costæ valde elongatæ, reliquæ parenchymaticæ, magnæ.* The plant is diœcious, and presents, according to the author, a transitional form between the thallose and the foliose Jungermanniaceæ.

Among the descriptions of a large number of new species of Hepaticæ by the same author † is one of a new genus from China which he names *Delavayella*:—*Planta bilateralis, mollis, cæspitans, erecta, parum ramosa, ramis ubique lateralibus, e basi caulis solum radicans; folia conferta, distiche patula, medio infero conduplicata, superne aperta, dimidio postico plano erecto, ad basim in sacculo commutato, antico decurvo revoluta in caulem longe decurrente, apice bifida serrata acuta. Cellulæ magnæ, trigonis distinctis instructæ; flores feminei terminales, pistilla numerosa; folia floralia 2, perianthium vaginatim amplectentia, longe carinata, superne bifida, patula, serrata; perianthium valde elongatum, compresso-cylindricum, haud plicatum, ore aperto quadrifido dentato; propagula in apice caulis subnudi, e margine squamarum orta, hyalina, globosa; inflorescentia dioica; mascula ignota.*

Herr J. B. Jack ‡ finds, among Hepaticæ gathered in Argentina and Bolivia, a remarkable species which he makes the type of a new genus *Stephaniella*, but the exact position of which he is unable to define, owing to the absence of reproductive organs. It is distinguished by its long and greatly branched rhizome, and by the great number of paraphylls which fill up the spaces between the leaves.

\* Oesterr. Bot. Zeitschr., xlv. (1894) pp. 1-5 (1 pl.).

† Hedwigia, xxxiii. (1894) pp. 1-10 (5 figs.).

‡ Tom. cit., pp. 11-4 (8 figs.).



*Pallavicinia decipiens*.\*—Prof. J. B. Farmer describes in detail the structure of this species of Hepaticæ from Ceylon—the vegetative organs the sexual organs, and the development of the spores. In the latter process the course of cell-division differs in some points from what has been observed in other cases. Four chromosomes make their appearance in the nucleus, preceded by the formation of a quadripolar spindle; and these four divide again into eight, and ultimately into sixteen, four of them going to form the nucleus of each spore. The shape of the chromosomes is not that of loops, but of rods. Similar processes were observed also in a few other Hepaticæ.

#### Algæ.

**Metastasis in Marine Algæ.**†—According to observations made by Herr A. Hansen, the Phæophyceæ do not produce starch as the result of assimilation, but oil. This was found in the reserve-cells of *Taonia atomaria*, in *Asperococcus*, *Cystosira*, and other genera. The oil is subsequently used up in the growth of the plant. Many Florideæ also contain no starch, but other substances which swell up in water, and are coloured brown by iodine and a dark tint by osmic acid, presenting certain resemblances to glycogen; they are nutrient substances produced in the chromatophore-cells. In the cells of *Gracilaria dura* and some other Florideæ, the author found starch-like grains which were coloured red-brown by iodine, becoming violet after heating. He was not able to separate the pigment in a pure condition, and believes it to be, in the plant, in a state of combination with an albuminoid. An identical substance was found in *Bryopsis*, *Taonia*, and *Dictyota*.

**New Genera of Algæ.**—Prof. J. G. Agardh describes the following new genera of Florideæ:—*Epiphleæ*, belonging to the Gigartineæ, near to *Kallymenia*; *Gloiophyllis*, separated from *Rhodophyllis*; *Tiarophora*, probably belonging to the Helminthocladiaceæ; *Lophothalia* and *Lophocladia*, separated from *Dasya*; *Lenormandia* and *Sonderia*, belonging to the Rhodomelaceæ. A monograph is given of the genus *Dasya*, comprising 54 species. *Gelinaria* is removed from the Solieriaceæ, and placed between *Corynomorpha* and *Pachymenia*; *Tyleiophora* probably belongs to the Sphærococcoideæ, and comes near *Tylotus*.

**Australian Marine Algæ.**§—Among a collection of sea-weeds from Australian localities, chiefly Brisbane and Adelaide, Herr E. Askenasy describes the little-known *Acetabularia Calyculus*, which is but slightly encrusted with lime, and contains, in the pedicel and pilous, large sphærocrystals of inulin. It appears to have a perennial base imbedded in the mussel-shells on which it grows. The following new species are also described and figured:—*Sphacelaria biradiata*, *Callithamnion ovuligerum*, *Cladophora fertilis*, *Merismopedia revolutiva*.

\* Ann. Bot., viii. (1894) pp. 35-52 (2 pls.).

† Mtthl. Zool. Stat. Neapel, xi. (1893) p. 256. See Bot. Ztg., lii. (1894) 2<sup>te</sup> Abtheil., p. 54.

‡ Lunds Univ. Arsskr., xxvi., 118 pp. and 3 pls. See Bonnier's Rev. Gén. de Bot., vi. (1894) p. 46. Cf. this Journal, ante, p. 89.

§ Flora, lxxviii. (1894) pp. 1-18 (4 pls. and 2 figs.).

**Phyllophora.**\*—Herr O. V. Darbishire describes in detail the anatomy and development of the three known species of this genus of Florideæ. The thallus is differentiated into a basal disk, and an erect stem-like thallus, branching into leaf-like structures. The thallus is composed of a cortex and a pith, the cells of which contain respectively rhodoplasts and leucoplasts. A secondary growth in thickness occurs in *P. membranifolia*. The reproductive organs consist of nematheces, antherids, and cystocarps. Experiments in germinating the tetraspores of *P. Brodiaei* were successful. No conjugation could be detected between the carpogone and the supporting cell.

The author altogether disputes the conclusions of Schmitz † that the so-called nematheces of *P. Brodiaei* and *rubens* are in reality parasitic algæ belonging to the genera *Actinococcus* and *Colacolepis*. They are, he asserts, the true nematheces of *Phyllophora*.

**Laminaria.**‡—Herr F. R. Kjellman distributes the species of this genus of Phæosporeæ under eight types, dependent on the arrangement and structure of the sori. One new species, *L. gyrata*, is described.

**Pores of Desmidiaceæ.**§—By staining with anilin dyes Dr. J. Lütke-müller finds, in all the larger species of *Closterium*, a great number of fine pores, the filaments of which have no terminal swelling. In other genera of desmids, on the contrary, the pore-filaments end in a capitate enlargement. In *Xanthidium armatum* the pore-filaments have very large clove-shaped terminal swellings, which are perforated by a central canal. In this and some other species there appear to be very fine pores in addition to the large ones. As far as present observations go, the species of *Closterium* and *Penium* which are provided with pores are destitute of the mucilaginous envelope possessed by other porous desmids.

The author suggests the division of the Desmidiæ into two primary groups, viz. :—(1) Those in which the cell-wall is composed of a single piece, is destitute of pores, and has no prismatic gelatinous envelope (*Mesotænum*, *Cylindrocystis*, *Spirotænia*); (2) those in which the cell-wall is composed of two halves (in some species of *Closterium* and *Penium* of several pieces), including all the other genera. *Gonatazygon* and some species of *Penium* are distinguished from the rest of this group by the absence of pores and of a gelatinous envelope. *Closterium* appears to occupy an intermediate position, from the absence of the gelatinous envelope, and the occurrence of pore-filaments which have no terminal capitate enlargement.

**Acrosiphonia.**||—Herr F. R. Kjellman describes in detail the structure of this genus of Cladophoraceæ. It is distinguished by the terminal cells of the rhizoids being filled with starch and giving birth to new individuals, and by the very elongated terminal cell of the

\* Bot. Centralbl., lvii. (1894) pp. 361-9. † Cf. this Journal, ante, p. 376.

‡ Bih. K. Svensk. Vetensk. Akad. Handl., 1893, 17 pp. and 1 pl. See Hedwigia, xxxiii. (1894), Rep., p. 42.

§ S.B. Zool.-Bot. Gesell. Wien, xliii. (1893) p. 38; Oesterr. Bot. Zeitschr., xlv. (1894) pp. 11-6, 49-53.

|| Bih. K. Svensk. Vetensk. Akad. Handl., 1893, 114 pp. and 1 pl. See Hedwigia, xxxiii. (1894), Rep., p. 11.

primary vegetative shoot. A monograph follows of the twenty Scandinavian species of the genus, some of which are new, while others have been placed under *Conferva*, *Cladophora*, and *Spongomorpha*.

**Radiofilum**, a new Genus of Chlorophyceæ.\*—Among a collection of Algæ from the turf-bogs of Virnheim, Herr W. Schmidle describes a new species and genus, *Radiofilum conjunctivum*, with the following generic characters:—Cellulæ adultæ rotundatæ v. subovatæ, inter se subremotæ et ponte vix visibili inter se conjunctæ, et ita fila brevissima fragilia libere natantia formantes. Cellulæ singulæ reagentiis adhibitis massa gelatinosa obvolutæ structura non lamellosa sed radianti; contentus chlorophyllosus ex uno v. rarissimo duobus chlorophoris parietalibus, superficiem non plane tegentibus, sæpe caliciformibus constitutus, cum uno v. duobus pyrenoidibus. An amended diagnosis is also given of *Tetracoccus*,† and the following new species described:—*Ædogonium* (?) *spirogranulatum*, *Tetracoccus Wildemani*, *Cosmocladium subramosum*, *Cosmarium regulare*, *C. subreinschii*, *Euastrum Richteri*. According to the author, the Desmidiæ are most abundant in the early part of summer, the Palmellaceæ in the early part of autumn.

**Rejuvenescence in the Siphonææ.**‡—Herr P. Klemm has attempted to solve the questions of the mode of rejuvenescence in the thallus of the Siphonææ and the cause of the movements in the protoplasm, by observing the results of artificial injuries. The observations were made chiefly on *Derbesia* and *Valonia*. He finds an accumulation of chloroplasts to take place at the spot immediately after the wound has been inflicted; but these soon disappear. When the filaments have been completely cut through, irregular and globular fibrous structures are flung on to the wounded spots with the force of an explosion. The causes of the movements in the protoplasm appear to be very complicated.

### Fungi.

**Sexual Reproduction in Fungi.**§—M. P. A. Dangeard gives a *resumé* of what is at present known with regard to the mode of sexual reproduction in the lower classes of Algæ and in Fungi (Ancylistæ, Entomophthoræ, Peronosporæ, Saprolegniæ, Uredinæ, and Ustilaginæ).

He describes a process, similar to that already detected in the Uredinæ,|| in several species of Ustilaginæ—*Ustilago receptaculorum*, *U. violacea*, *Doassansia Alismatis*, and *Etyloma* sp. The cells hitherto considered to be spores are, in reality, oogones containing oospheres. Each cell contains two nuclei which behave respectively as male and female nuclei. These are very small, and frequently have the appearance only of chromatic spots; in the most favourable cases an enveloping membrane and a nucleole could be detected. When impregnation takes place the protoplasm of the oogone contracts, and the two nuclei fuse

\* Flora, lxxviii. (1894) pp. 42-66 (1 pl.).

† Cf. this Journal, 1892, p. 735.

‡ Flora, lxxviii. (1894) pp. 19-41 (2 pls.). Cf. this Journal, ante, p. 376.

§ Comptes Rendus, cxvii. (1893) pp. 496-7; cxviii. (1894) pp. 547-9, 1065-6; Le Botaniste (Dangeard), iii. (1894) pp. 222-39.

|| Cf. this Journal, 1893, p. 667.



into a single central nucleus; the surface of the contracted protoplasm clothes itself at the same time with a double membrane, the outermost layer often displaying sculpturings characteristic of the species. Oosperms are thus formed, corresponding to those of *Pythium* or *Leptomitus*. When the oosperm (of *Urocystis Violæ* or *Tilletia caries*) germinates, its nucleus passes first of all into the promycele, which then forms at its apex eight sporids; as these elongate, the nucleus undergoes three successive bipartitions; a daughter-nucleus enters into each sporid; and these again form other sporids attached to the first by a slender pedicel.

MM. P. A. Dangeard and M. Léger give a detailed description of the structure of the zygosperm in the Mucorini in the case of *Sporodinia grandis*.

In the Ascomycetes (*Peziza vesiculosa*) M. P. A. Dangeard has also been able to detect a process of sexual reproduction, similar to that observed by Lagerheim in *Dipodascus albidus*.\* The asci proceed from oosperms which result from the anastomosis of two conjugating filaments or gametes. In the production of an oosperm two filaments come into contact; in each of them a terminal cell containing a single nucleus is cut off by a septum; these cells are the gametes; in the process of conjugation their protoplasm mingles, and the two large nucleolated nuclei almost immediately unite. The oosperm thus formed then elongates into a tube which swells up into the form of an ascus; the sexual nucleus enters it and moves to its apex, and then undergoes division, furnishing a nucleus to each embryo or ascospore.

**Insertion of Spores and Direction of the Septa in Protobasids.** †—M. P. Vuillemin points out that, while in some Fungi, as the Tremellineæ, the spores are inserted on the apex of the protobasids, in others, such as the Auricularineæ and Puccinieæ, their insertion is lateral. A similar diversity occurs in basids, which may have terminal or lateral sterigmata, and in asci, where the ascospores may be in a single row, or in clusters. The lateral position of the spores may be considered the primitive one, corresponding to the transverse segmentation of the thallus. The difference between the two types depends on an acceleration of development, and on a phenomenon of secondary adaptation, and does not affect the separation of the Protobasidiomycetes as a primary division of Fungi, consisting of the three suborders Auricularineæ, Puccinieæ, and Tremellineæ.

**Sapromyces (Nægelia).** ‡—Mr. R. Thaxter describes the structure and development of this rare genus of Saprolegniaceæ (*Nægelia* of Reinsch, *Nægeliella* of Schröter) found on fir-cones in the state of Maine. It is closely allied to *Rhipidium*, differing from that genus in the absence of any differentiation between the basal cell of the hyphæ and those of its branches.

**Nuclei of the Mucorini.** §—MM. P. A. Dangeard and M. Léger have studied the structure and distribution of the nuclei in various Mucorini

\* Cf. this Journal, 1893, p. 366.

† Comptes Rendus, cxviii. (1894) pp. 84-7. Cf. this Journal, 1893, p. 668.

‡ Bot. Gazette, xix. (1894) pp. 49-55 (1 pl.).

§ Comptes Rendus, cxviii. (1894) pp. 430-2.



(*Sporodinia grandis*, *Mucor Mucedo*, *M. racemosus*, &c.); their structure does not differ essentially from that in the Saprolegniaceæ, Ustilaginæ, and Uredinæ. Each nucleus has a nuclear membrane, separated from a central nucleole by cytoplasm, which is uncolourable, or contains but little chromatin; the nucleole is very dense, and is strongly stained by colouring reagents. The zygosperm contains a considerable number of nuclei, the nucleole of which is coloured red, while the protoplasm remains violet. There are a considerable number of nuclei in the mycelle, in the chlamydospores, and in the budding spores; the spores otherwise only contain one, or rarely two. The two gametes contain a number of nuclei, which are derived from the thallus.

**Structure of the Ustilaginæ.\***—M. P. A. Dangeard describes in detail the structure of the following species of Ustilaginæ,—*Ustilago Tragopogonis*, *U. carbo*, *U. violacea*, *Doassansia Alismatis*, *Entyloma Glaucii*, *Urocystis Violæ*, *Tilletia caries*. The structure of the mycelle and the mode of germination of the spores present peculiarities in each case. Various processes previously described as sexual in *Eurotium* and *Tilletia* have not that character; the true sexual process consists in the fusion of nuclei within the ascus. The author accepts Frank's union of the Ustilaginæ and Uredinæ into a class of MESOMYCETES, representing an intermediate stage of evolution between the Phycomyces on the one hand, and the Basidiomycetes and Ascomycetes on the other hand. The so-called spores of the Ustilaginæ, and the teleutospores of the Uredinæ are homologous to oogones.

**Ustilago producing Woody Tumours.†**—Under the name *Ustilago Vriesiana* M. P. Vuillemin describes a new species which forms woody tubers in various species of *Eucalyptus*, resembling the well-known "chaudron" of the spruce fir. This is the first time that such a property has been observed in any species of *Ustilago*. The structure of the parasite is described, and that of the tumour in detail. The latter consists of a woody structure penetrated by fine canals, and with irregular intercellular spaces. The local lesion produced by the parasite is more fatal to the fungus itself than it is to the host.

**Exoasceæ.‡**—Dr. R. Sadebeck gives a monograph of the parasitic Exoasceæ, comprising the three genera *Exoascus* (21 sp.), *Taphrina* (15 sp., including *Taphrinopsis*), and *Magnusiella* (5 sp.). To the same family belong also the following saprophytic genera,—*Eremascus*, *Ascodermis*, *Podocapsa*, *Oleina*, *Eremothecium*, *Bargellinia*, *Endomyces*, and *Ascocorticium*.

**Structure of Lichens.§**—M. P. A. Dangeard brings forward several points in the structure of lichens which confirm Schwendener's theory.

In the algal constituent, the body which has hitherto been taken for a nucleus is in reality a pyrenoid; the true nucleus, which is nucleolated, is situated beneath the membrane, and has been described as a vacuole. By the use of the proper reagents, the protoplasm can be stained yellow,

\* Le Botaniste (Dangeard), iii. (1894) pp. 240-81 (4 pls.).

† Comptes Rendus, cxviii. (1894) pp. 933-6.

‡ Jahrb. Hamburg Wiss. Anstalt, 1893, 110 pp. and 3 pls. See Bot. Centralbl., lvii. (1894) p. 334. Cf. this Journal, 1886, p. 489.

§ Comptes Rendus, cxviii. (1894) pp. 931-2.

the pyrenoid blue, and the nucleus red. All the stages of nuclear division have been followed out in the bipartition of the gonids of *Physcia parietina*, *Anaptychia ciliaris*, and *Gyrophora pustulata*. A similar structure can be demonstrated in the Trentepohliaceæ which form the gonids of *Graphis* and *Opegrapha*, and in the *Protococcus* of *Endocarpon*.

The mycelial portion of these lichens presents all the points of structure proper to Fungi. The filaments anastomose and are septated; the cells usually contain only a single nucleus (*Physcia*, *Anaptychia*, *Peltigera*, *Gyrophora*, *Parmelia*, *Collema*, &c.), less often two or three (*Collema*, *Peltigera*). In the peritheces the paraphyses are uninucleated. The crustaceous portions of Lichens are not destitute of vitality; even in the rhizines, the presence of protoplasm and of active nuclei can be demonstrated.

**New Substance extracted from Lichens.\***—Sigg. E. Paternò and F. Crosa find that *Lecanora (Zeora) sulphurea* Schaer., a lichen which grows on calcareous rocks in the province of Palermo, contains a substance, which on certain treatment (with melted potash) yields caproic acid. This is the first time that a lichen has been known to yield a fatty acid somewhat high up in the series. The authors did not discover what else besides caproic acid is formed by the action of potash on the new substance, for which the formula  $C_{27}H_{30}O_9$  is suggested.

**Crombie's British Lichens.†**—The Trustees of the British Museum have published the first part of the Rev. J. M. Crombie's Descriptive Catalogue of the species in the Herbarium, constituting a Monograph of British Lichens. The classification followed is essentially that of Nylander, the order being divided primarily into four families, the Ephebacei, Collemacei, Lichenacei, and Myriangiacei. Each genus is depicted by at least one illustration of the characteristic points of structure.

**Recent Researches on Saccharomycetes.**—Dr. A. A. Kanthack, in a review of the translation of A. Jørgensen's work on 'Micro-Organisms and Fermentation' well sums up the work of Hansen, to which reference has from time to time been made in this Journal. "Hansen cleared the hopeless confusion existing regarding the Saccharomycetes, by finding methods for obtaining pure cultures, and separating and distinguishing various allied forms, which, though hitherto included under the same name, were mere impurities." It is only among Saccharomycetes that organisms capable of fermenting maltose rapidly and vigorously are found. For industrial purposes pure yeast cultures should be used for brewing, and Hansen's system is applied in too few of the English breweries.

**Parasitic Fungi.**—M. G. Delacroix § records the occurrence of *Oospora (Isaria) destructor*, parasitic on silkworms, producing a green muscardine.

Mr. W. C. Blasdale || describes the life-history of a species of

\* Atti R. Accad. Lincei, 1894, pp. 219-25.

† 'A Monograph of Lichens found in Britain,' pt. i., London, 1894, Svo, 519 pp. and 74 figs.

‡ Nature, xlix. (1894) pp. 527 and 8.

§ Bull. Soc. Mycol. France, 1893, p. 260 (1 pl.). See Bot. Centralbl., lvii. (1894) p. 239.

|| Rep. Agric. Exp. Stat. California, 1891, 2, pp. 227-32. See Bot. Centralbl., lvii. (1894) p. 240.

*Puccinia* apparently identical with *P. heterantha*, parasitic on *Ænothera ovata* and on a number of other species of Onagraceæ in California.

Herr P. Magnus\* has found the parasitic fungus *Synchytrium papillatum* on material from Teneriffe. The form of the fungus from this locality presents the peculiarity that the pear-shaped epidermal cells of the host-plant, which are attacked by the resting sporanges of the fungus, become detached, and fall to the ground together with the parasite. The zoospores are developed within the resting sporange while still enclosed within the cell as it lies on the ground.

Herr H. Zukal† finds two species of Chytridiaceæ parasitic on *Tolypothrix lanata*, viz. *Rhizophlyctis Tolypothrichis*, and a *Myzocyttium*; the latter forms within the host abundant siphon-like mycelial threads. The systematic position of the former genus is somewhat doubtful.

M. E. Prillieux‡ describes the ravages effected on the artichoke by the attacks of *Ramularia Cynaræ*.

Dr. C. Brick§ describes the structure and development of the destructive parasite *Nectria cinnabarina*. It produces three different kinds of spore—ascospores, microspores, and multicellular sickle-shaped megaspores, corresponding respectively to the *Nectria*, the *Tubercularia*, and the *Fusisporium* forms. Propagation takes place entirely through the agency of one or other of these different kinds of spore.

Herr C. Wehmer|| confirms Dr. Brick's account in all essential particulars.

Mr. S. A. Beach¶ describes the phenomena of anthracnose of the bean produced by *Colletotrichum Lindemuthianum*; of a disease of the bean due to bacteria; and of the rust caused by *Uromyces Phaseoli*.

M. G. Neumann\*\* describes the ravages caused in wheat-crops by a hitherto unknown disease produced by *Mystrosporium abrodens*, a new species belonging to the family Dematiaceæ of Hyphomycetes.

Herr P. Magnus†† advances arguments in favour of his conclusion that the æcidia on *Convallaria*, *Polygonatum*, *Maianthemum*, and *Paris*, all belong to the same species of *Puccinia* found on *Phalaris arundinacea*.

Mr. L. H. Pammel‡‡ describes the effects of *Cladosporium carpophilum* in producing the disease known as scab on the plum and cherry; and of *Sphærotheca Mali* in causing the powdery mildew of the apple.

Uredineæ and their Hosts.§§—M. G. Poirault gives a supplementary list of phanerogamic plants, arranged in their natural orders, on which species of Uredineæ have been observed to be parasitic.

\* Ber. Deutsch. Bot. Gesell., xi. (1895) pp. 538-42 (1 pl.).

† Oesterr. Bot. Zeitschr., xliii. (1893) pp. 310-14 (1 fig.).

‡ Bull. Soc. Mycol. France, viii. (1892) pp. 144-6. See Bot. Centralbl., 1894, Beih., p. 50.

§ Jahrb. Hamburg. Wiss. Arb., x. (1893) 14 pp. See Bot. Centralbl., lvii. (1894) p. 270.

|| Zeitschr. f. Pflanzenkrankheiten, 1894, p. 74 (1 pl.).

¶ Bot. Deptmt. Agric. Coll. Ames, 1892, pp. 307-33 (9 figs.). See Bot. Centralbl., lvii. (1894) p. 311.

\*\* Soc. Biol. Toulouse, Dec. 24, 1892, 3 pp. See Bot. Centralbl., lvii. (1894) p. 313.

†† Hedwigia, xxxiii. (1894) pp. 77-83. Cf. this Journal, ante, p. 238.

‡‡ Bull. Iowa Agric. Coll. Exp. Stat., 1893, pp. 918-24 (2 figs.).

§§ Journ. de Bot. (Morot), vii. (1893) pp. 391-2; viii. (1894) pp. 16-8, 106-8, 148, 163-4, 173-7. Cf. this Journal, 1891, p. 231.

**Ravenelia.\***—Herr P. Dietel gives a monograph of this genus of Uredineæ. The remarkable cysts or sterile cells, which are peculiar to the genus, appear to be a contrivance for detaching the parasite from its host. The author classifies the 27 species (some of them new) under 5 sections,—*Euravenelia*, *Raveneliopsis*, *Brachyravenelia*, *Hemiravenelia*, and *Microravenelia*.

**Polysaccum.†**—Dr. E. Bruns describes the structure and development of this genus of Gasteromycetes, especially of *P. crassipes*. The so-called "root-portion" is often the most strongly developed, and this frequently forms a weft round fir-roots, constituting a kind of mycorrhiza, which is, however, by no means essential for the nutrition of the pine-roots.

**Rhizobes.‡**—In the tubercles of *Melilotus albus* Herr A. Schneider finds two species of *Rhizobium*, *R. Frankii* and *mutabile*. The latter is intimately associated with the cytoplasm of the cells, and is identical with the so-called bacteroids. The former is motile, and has usually two cilia, one at each end, sometimes only one; the spores have often three or four cilia. It increases more rapidly than the bacteroids and effectually prevents their multiplication. By its movements it incites the cytoplasm to surround itself with a wall of cellulose, thus causing the formation of the meristem of which the tubercle is composed. The author does not believe that the rhizobe has the power of either perforating or dissolving the cell-wall. The tubercles of *Pisum sativum* contain also two kinds of rhizobe; the smaller one is named *R. sphaeroides*.

#### Mycetozoa.

**New Myxomycetes.**—Mr. T. H. McBride§ gives a monograph of the Myxomycetes of Eastern Iowa, including in the class *Plasmodiophora Brassicæ* as the sole representative of a primary division, the *Phyto-myxinæ*. A number of new species are also described from Nicaragua, Iowa, and Colorado.

Mr. E. J. Durand|| describes several rare Myxomycetes from the State of New York, and the germination of the spores of *Enteridium Rozeanum*, the swarm-cells of which are peculiar in having often two cilia, one at each end.

*Plasmodiophora Brassicæ.*¶—In addition to the hosts already recorded for this parasite, Prof. B. D. Halsted finds it on the roots of other species of Cruciferae, especially *Capsella bursa-pastoris* and *Sisymbrium vulgare*.

#### Protophyta.

##### a. Schizophyceæ.

*Cryptoglæna americana* sp. n.\*\*—Under this name Mr. B. M. Davis describes a new unicellular blue-green motile organism from a salt

\* Hedwigia, xxxiii. (1894) pp. 22-69 (5 pls.). Cf. this Journal, 1889, p. 791.

† Flora, lxxviii. (1894) pp. 67-75 (1 pl.).

‡ Ber. Deutsch. Bot. Gesell., xii. (1894) pp. 11-7.

§ Bull. Lab. Nat. Hist. State Univ. Iowa, ii. (1893) pp. 99-162, 377-90 (12 pls.).

|| Bot. Gazette, xix. (1894) pp. 89-95 (2 pls.).

¶ Bull. Torrey Bot. Club, xxi. (1894) pp. 76-8 (2 figs.).

\*\* Bot. Gazette, xix. (1894) pp. 96-102 (1 pl.).



marsh near Cambridge, Mass. In the motile condition it consists of a swarm-cell about 8–10  $\mu$  long and 5–6  $\mu$  broad, with two unequal cilia at one end. It contains six to ten peripheral disc-shaped bodies which are apparently true chromatophores, and one or two bright red pigment-spots. It occurs also in a non-motile condition, which is possibly identical with *Polycystis pallida*. In this state the cells contain blue-green chromatophores, one, two, or rarely three pigment-spots, and a well-defined nucleus with a distinct nucleole.

**Influence of Light and of Altitude on the Striation of Diatoms.\***—M. J. Hérivaud has examined a number of diatoms belonging to the genera *Gomphonema*, *Navicula*, *Stauroneis*, and *Synedra*, attached to *Isoetes* obtained from a depth of 10–12 m., and from Characeæ at a depth of 15 m., in a lake in Auvergne. Contrasted with the same species growing on the borders of the lake, he finds the frustule to be generally longer and broader, and the number of striae to be diminished by the comparative feebleness of the light. In diatoms of the same genera obtained from an altitude of 1830 m., the striae were also less numerous and less strongly marked.

### β. Schizomycetes.

**The State and Modern Bacteriological Research.†**—Prof. O. Babes gave an important address to the International Medical Congress at Rome on this subject. Considering the organization of hygiene as being of the greatest importance for the happiness of citizens, he thinks that there should be a richly-endowed Institute of State Hygiene, in which laboratory work may be turned to practical use; the position of the sanitary officials should be raised, and all the strength of the department used to fill up lacunæ in professional knowledge. Our enlarged experience will justify us in increasing the sphere of state work, which is bound to interfere more largely in the freedom of individual life, because modern research tells us that this is in favour of the sanitary development of the community.

**Morphology of Bacteria.‡**—Dr. E. Klein concludes from observations on the bacilli of anthrax, diphtheria, and tubercle, that these species are not such typical bacilli as they are usually represented to be. For though under many conditions their morphological characters are those of typical bacilli, yet under others they revert to or assume forms indicating their relationship to *Saccharomyces* or a still higher mycelial fungus. In the case of anthrax, the typical bacilli may be represented by oval and spherical bodies, some of which may contain vacuoles, and under other conditions (early stages of growth on plates composed of beef bouillon, gelatin 10 per cent., pepton 1 per cent., salt 1 per cent.), the colonies are composed of large spindle-shaped, spherical or oval elements in which vacuolation is frequent. Similar appearances are to be observed in colonies of the thrush fungus. From this it is inferred that while *B. anthracis* is a typical bacillus as a pathogenic microbe, yet in its early stages of growth on gelatin it may assume characters having much resemblance to *Saccharomyces mycoderma* or *Oidium*, and thus

\* Comptes Rendus, cxviii. (1894) pp. 82–4.

† Nature, xlix. (1894) pp. 565–7.

‡ Quart. Journ. Micr. Sci., xxxvi. (1894) pp. 1–9 (1 pl.).

return temporarily to an atavistic stage in its evolutionary history. With regard to *B. diphtheriæ* the author points out that the club-shaped expansions of one or both ends are not to be regarded as due to involution, for both under natural and artificial conditions where there is active growth these expansions will be found, and have moreover a striking resemblance to the ends of growing hyphæ. Their existence, therefore, is only to be explained by their representing a relationship to a mycelial fungus. In the case of the tubercle bacilli, preparations not unfrequently show threads or filaments composed of unequal elements, some of them being conspicuous for knob-shaped expansions, similar to those of diphtheria. Such appearances occur not only in sputum but in artificial cultivations, e. g. glycerin agar after some weeks incubation at 37°. All these preparations behave in the same way as *B. tuberculosis* when treated with appropriate staining reagents; and that they are not involution forms is evident, as the unbranched nature of the filaments and the existence of lateral bulgings prove that they are in an active condition of growth.

**Bacillar Diseases of Plants.\***—MM. E. Prillieux and G. Delacroix describe a disease of various cultivated plants produced by a bacillus about 1.5  $\mu$  long and 0.33–0.5  $\mu$  broad, closely resembling that already described as *Bacillus caulivorus*. It was observed on the potato, *Pelargonium*, *Clematis*, *Begonia*, and *Gloxinia*. Similar, but probably not identical, bacilli also attack the vine (the fruit, less often the stem), *Cyclamen*, tobacco, tomato, and *Gladiolus*; while apples of various kinds are attacked by a *Micrococcus*.

**Microbes which evolve Hydrogen Sulphide.†**—M. N. Zelinsky has obtained from ooze in the Black Sea a microbe which he names *Bacterium hydrosulfureum ponticum*, which has the power of evolving hydrogen sulphide from the nutritive media in which it is cultivated, and even of decomposing inorganic sulphates and sulphites. A microbe with similar properties, *Vibrio hydrosulfureus*, has been obtained from the estuary at Odessa.

**Influence of Light on Pyogenic Microbes.‡**—Dr. P. A. Khmelevsky finds that both solar and electric light inhibit the growth of *Staphylococcus pyogenes*, *Bacillus pyocyaneus*, *Streptococcus erysipelatis*, and *S. pyogenes*; sunlight destroys their vitality in about six hours, and exposure to sunlight seems to mitigate the virulence of the microbes. Exposure of agar-agar and jelly to light makes the media less favourable for the growth of bacteria.

**Leucocytes and Bactericidal Power.§**—Prof. J. Denys and Dr. J. Havel find that filtered dog's blood loses almost entirely its bactericidal power; this points to the power lying in the white corpuscles. The energetic destruction of microbes effected by "complete blood" is the result of their ingestion by leucocytes. This is effected in their interior

\* Comptes Rendus, cxviii. (1894) pp. 668–71. Cf. this Journal, 1890, p. 758.

† Journ. Russ. Chem. Soc., xxv. pp. 298–303. See Journ. Chem. Soc., 1894, Abstr., p. 200.

‡ St. Petersburg Inaug. Diss., 1893, No. 46, 40 pp. See Brit. Med. Journ., No. 1740 (1894) p. 72.

§ La Cellule, x. (1894) pp. 7–35. Cf. this Journal, 1893, p. 776.

and not under the influence of a bactericidal product secreted by the leucocytes into the serum under the stimulus of the microbes. The bactericidal power of blood may be restored to it by adding living pus-corpuseles. With the aid of the Microscope all the phases of phagocytosis may be watched. A very small part of the bactericidal power of the dog's blood is ascribed to the serum. The filtered blood and the serum of man are almost as bactericidal to the common bacillus of the intestine as non-filtered blood; and the same is true of the blood of pigeons and fowls.

As a general result the authors conclude that immunity is not to be explained either by the phagocytic theory or by the theory of humours taken singly. Phagocytes and humours work together, in a varying degree in varying species, and with differences according to the nature of the aggressor, in order to preserve higher organisms against the invasion of microbes.

**Bactericidal Properties of Potash-Albumen.\***—The experiments of Buchner, Emmerich, and others have shown that when blood-serum is heated to 57° it loses its bactericidal properties, and that these are restored if a little caustic potash be added. Dr. H. Scholl has made some experiments with the view of ascertaining if bactericidal properties could be imparted to other proteid bodies by the mere addition of caustic potash. For this purpose white of egg obtained with due anti-septic precautions was mixed with 0·3 per cent. caustic potash and the mass dialysed for 24 hours in 0·75 per cent. cooking-salt solution. This dialysed potash-albumen was then inoculated with typhoid bacilli and plate cultivations made directly after, three hours after, and six hours after inoculation. In the first plate 90,000 colonies grew up; in the second 500, and in the third only 5. The albumen and globulin of the egg were then separately examined according to the foregoing method, and analogous results were obtained from both. The bactericidal properties were not destroyed by heating up to 100°.

**Anaerobic Micro-organisms.†**—After discussing the technique for the cultivation of anaerobic organisms, Sig. Sanfelice describes the growth and pathogenic properties of tetanus, symptomatic anthrax, malignant œdema, and nine other anaerobic bacteria found in earth, rotten meat, and fœces. The last nine are not pathogenic, and their growth is not distinguishable on agar, but only on gelatin, which is liquefied with the production of an ill-smelling gas. How frequently the bacilli of malignant œdema and of tetanus occur in the earth, the author shows by a number of experiments, for out of forty-eight guinea-pigs inoculated with surface earth, three died of tetanus and nineteen of malignant œdema. In another series twenty-two guinea-pigs were inoculated with earth taken from different depths, and of these twelve succumbed to malignant œdema and two to tetanus.

In twelve other instances the animals died from other diseases. Some of these samples of earth were kept in the dark at 20° for several

\* Archiv f. Hygiene, xiii. See *Centrabl. f. Bakteriologie u. Parasitenkunde*, xv. (1894) p. 511.

† *Zeitschr. f. Hyg. u. Infektionskrankh.*, xiv. See *Centrabl. f. Bakteriologie u. Parasitenkunde*, xv. (1894) p. 488-9.



months and then used for inoculation experiments, with the result of ten deaths from malignant œdema and two from tetanus. Eighteen other samples were mixed with bouillon and inoculated for 8-10 days at 37°. All the animals inoculated therewith died of tetanus. It is noteworthy that the author never found the organism of symptomatic anthrax in the earth, though the disease is not uncommon in upper Italy.

Contemporaneous action of two poisons hastens death, and a combination of the metabolic products of a pathogenic and non-pathogenic anaerobe has the same result. A tetanus culture which kills guinea-pigs in three days, and a culture of malignant œdema, fatal in 24-36 hours, will in combination kill in 14-18 hours with tetanic phenomena. By the simultaneous use of symptomatic anthrax and of malignant œdema, the pathological results point rather to malignant œdema than to the former disease.

Acceleration of death by inoculation with a pathogenic and non-pathogenic species results both when inoculation is simultaneous or when the non-pathogenic organism is first injected. The simultaneous infection with aerobes and non-aerobes has no accelerating effect. When the tetanoid anaerobes were cultivated on a nutrient medium which contains the tetanus poison they acquired toxic properties, but analogous results were not obtained from malignant œdema or from Rauschbrand.

**Vibrios and the Production of Lactic Acid.\***—Dr. J. Kuprianow made experiments with a large number of different kinds of vibrios in order to ascertain whether bacteria belonging to the same morphological group formed the same acids, or whether any differences were to be determined. He found that by *Vibrio aquatilis* an inactive lactic acid is formed, by *Vibrio Deneke*, Koch, *Finckler-Prior*, and *Metschnikovi* an active one, *V. Deneke* turning to the right, the other three to the left. *Vibrio Koch* forms most lactic acid and decomposes most sugar, while *Vibrio Deneke* decomposes least sugar, forming proportionately little lactic acid. In the other three cases the consumption of sugar and the formation of acid was not found to go hand in hand. Besides lactic acids other products in variable quantity were formed.

Other experiments with *V. Deneke*, *Bonhoff a* and *b*, and *Berolinensis* showed that all four made lactic acid; that from *V. berlinensis* and *Bonhoff a* being inactive. That from *Bonhoff a* formed a modification turning to the right, and the *Vibrio Weibel* one turning to the left.

**Duration of Incubation of Air and Water Micro-organisms on Gelatin.†**—Dr. P. Miquel shows from a series of experiments recorded in tabular form that it is absolutely necessary to observe gelatin cultivations of water and air bacteria for 15-30 days, if an approximately correct estimate is desired. The author finds that a calculation based on data derived from growth occurring between the 15th and 30th day of cultivation in gelatin will suffice to give a fairly correct judgment, and suggests that experimenters should append to their analyses the times when the colonies have been counted, and should, moreover, refrain from

\* Arch. f. Hygiene, xix. (1893) No. 3. See Centralbl. f. Bakteriol. u. Parasitenk., xv. (1894) p. 489.

† Ann. de Micrographie, vi. (1894) pp. 111-8.



comparing data obtained on the second or third day of cultivation with those of the eighth or fifteenth.

**Pigment production of *Bacillus pyocyaneus* in Symbiosis with other Organisms.\***—Herron R. Mühsam and C. Schimmelbusch point out that it has been known for a long time that the access of air, the nutrient medium, and the idiosyncrasy of the bacilli, are of extreme importance for the development and quality of the pigment formed by *B. pyocyaneus*; and these authors show that this pigment formation is influenced by symbiosis with other micro-organisms. *Pyocyaneus* in association with *St. pyogenes*, *Tetragenus*, *Anthrax*, *Aspergillus fumigatus*, *Oidium lactis*, and a fungus from sour milk, loses its chromogenic property entirely or nearly so. Green *Pyocyaneus* cultivations when inoculated with *St. aureus*, *St. tetragenus*, bacilli of sour milk, lose colour. When *Pyocyaneus* is inoculated on cultivations of *Staphylococci*, *Anthrax* or *Tetragenus*, a green colour will develop, but this soon disappears, and this loss of the colour-producing power is not ascribable to death of the bacilli, nor to any change in the reaction of the medium. Hence the alteration is not due to any simple chemical change, and the explanation requires further observation.

**Physiological Effect of Metabolic Products of *B. Hydrophilus fuscus*.**†—*Bacillus hydrophilus fuscus* is an organism pathogenic to frogs. It resembles the bacillus of enteric fever, is easily stained by anilin dyes, is decolorized by Gram, grows on the usual media, does not liquefy gelatin, thrives well at the body temperature, and is pathogenic to numerous animals. The metabolic products of this organism have been examined by Dr. A. Trambusti, who found that the best way to isolate them was to precipitate with absolute alcohol, for by this means two groups of substances are at once separated, one precipitated, one remaining in solution. Experiments made with the soluble products of this organism come under three categories: physiological effect (1) of the pure culture; (2) of substances precipitated by alcohol; (3) of products soluble in alcohol.

The experiments had reference mainly to the effect on nerves and muscles, and the heart. The products of *Hydrophilus fuscus* were found to be divisible into two groups, one of which had a paralytic effect, and the other an exciting action on the muscles, nerves, and heart, and thus having some resemblance to caffeine and veratrin. There exist therefore in these products two substances having antagonistic physiological action.

**Intracellular Bacterial Poisons.‡**—Comparatively recently Dr. E. Klein brought forward evidence to show that certain pathogenic organisms, *Cholera vibrio*, *Vibrio Finkler*, *Bacillus prodigiosus coli*, and *typhosus*, and also *Proteus vulgaris*, contained within their cell-substance the same poison, and this, when injected into the peritoneal sac of guinea-pigs, produced the same symptoms and the same pathological changes.

\* Arch. f. Klin. Chirurg., xlvi. (1893) No. 4. See Centralbl. f. Bakteriologie u. Parasitenk., xv. (1894) p. 430.

† Beitr. z. Pathol. Anat. u. Allgem. Pathol., xiv. (1893) No. 2. See Centralbl. f. Bakteriologie u. Parasitenk., xv. (1894) pp. 607-8.

‡ Centralbl. f. Bakteriologie u. Parasitenk., xv. (1894) pp. 598-601.

And further, it was found that an injection with a sufficient quantity of the living or sterilized cell-substance of any one of these species protected against a further intra-peritoneal injection with living cultivations of the same or the other species. These observations were corroborated and extended by Sobernheim, but controverted by R. Pfeiffer, and the author then pursued a similar train of experiments with three other pathogenic organisms.

(1) *Bacillus anthracis*. 48-hour cultivations on agar at 37° were scraped off into tubes containing 5 ccm. of bouillon. To kill any spores present the tubes were placed in boiling water for 5 minutes. Intra-peritoneal injections were then made with two-thirds of cultivation on guinea-pigs. This was repeated twice, the animals remaining healthy. After a lapse of 4-5 days, the animals received an intra-peritoneal injection of living agar culture, and died in 48 hours of typical anthrax.

(2) *Bacillus diphtheriæ*. Similar experiments were made with exactly the same result.

(3) *Bacillus* of fowl cholera. The experiments were on similar lines, but rabbits were substituted for guinea-pigs.

It was obvious, from these experiments, that large quantities of the dead cell substances of these pathogenic microbes, when injected into the peritoneal sac, neither excited a disease nor imparted any resistance. Hence there is a fundamental difference between the two classes of organisms.

**Micro-organisms of Rancid Butter.\***—Dr. V. von Klecki describes five new microbes, which he has isolated from rancid butter, by first cultivating on plates, and then transferring to tubes. In every case the cultivations were submitted to microscopical examination. They were grown in milk-pepton-gelatin, and in milk stained with litmus. Those cultivations which had acidified milk were further examined in Petri's capsules, or on ordinary plates. When thoroughly pure they were further examined on other media, such as neutral milk-serum-gelatin, alkaline meat-extract gelatin, beerwort-gelatin, agar, grape-sugar meat-extract bouillon, potato and milk. The mobility was ascertained from hanging drop cultivations.

(1) *Bacillus* 0.4  $\mu$  thick and 2  $\mu$  long, with rounded ends. White growth on gelatin, non-liquefying, acidifies sterilized milk, but does not coagulate it. Is called *B. butyri* i.

(2) *Diplococcus* frequently forming chains. Diameter about 1  $\mu$ . Liquefies a gelatinous medium; growth whitish or yellowish white.

(3) *Bacilli* 0.8  $\mu$ –1  $\mu$  thick, 2  $\mu$  long, sometimes running to threads 10  $\mu$  long. Gelatinous media are not liquefied; growth a yellowish-white deposit. In alkaline meat-extract gelatin, spore-formation was observed, the ends of the rodlets swelling out to 1.5  $\mu$  thick, so that they assumed an hour-glass form. These spores were easily stainable by the usual methods.

In bouillon and in milk-serum gelatin, a well-marked capsule was developed, and in hanging drops, characteristic movements observed. This species, also grown on agar and potato, is called *B. limbatus butyri*.

\* Centralbl. f. Bakteriol. u. Parasitenk., xv. (1894) pp. 354-62.

(4) Tetracocci, double-celled diplococci. Length of a double cell about  $1.5 \mu$ , thickness  $1 \mu$ . The diplococci may be connected in pairs or chains or heaps. *Tetracoccus butyri* grows well on the usual media, does not liquefy gelatin, or exhibit any movements. It acidulates milk, but does not coagulate it.

(5) *Bacillus butyri* ii. is  $1-2 \mu$  thick,  $3-6 \mu$  long, forms a whitish growth on gelatin, which it does not liquefy. In bouillon drop cultivations, movements were observed.

All the five organisms grew well at  $20^{\circ}-35^{\circ}$  C. They stained well with methyl-violet, fuchsin, &c., but were decolorized by Gram's method. Inoculations on animals were negative.

**Streptococci.\***—According to Dr. A. Pasquale, Streptococci cannot be differentiated into species, and he suggests the following basis for their natural classification:—

- (1) Short saprophytic streptococci.
  - a. Growing at low temperatures, e. g. those of fæces and external environment.
  - b. Those of mouth and respiratory mucosa.
- (2) Long non-virulent streptococci.
  - a. Fæcal, e. g. *S. coli gracilis*.
  - b. From oral mucosa (Krase and Pansini).
- (3) Long pathogenic streptococci.
  - a. Erysipelas, pus, pneumonia, diphtheria, scarlatina.
  - b. Pneumonic sputum.
- (4) Short highly infectious streptococci.
  - a. Tuberculosis, &c. (*Diplococcus pyogenes*).
  - b. Pneumonia (*D. pneumoniæ*).

This classification is not intended to draw sharp lines of demarcation between streptococci, but on the contrary, to indicate the natural connection existing between them.

The most important criteria for the differentiation of streptococci may be obtained from the microscopical and cultural appearances in alkaline bouillon, as in this medium the characters of streptococci are best brought out. When cultivated in different kinds of serum it was noted that in rabbit serum the same streptococcus thrived well, badly, or did not develop at all, according to the individual from which the medium was derived; and the author also records another interesting fact about streptococci which produce septicæmia in rabbits, viz. that these may generate a blood-red pigment when the nutritive medium is suitable and oxygen absent.

Experiments as to the pathogenic properties of streptococci were made on mice and rabbits by injecting into abdominal cavity or subcutaneously fresh bouillon cultivations. In some cases a fatal issue was attended by presence of the streptococci in the blood, in others, the organisms were found in the viscera, but not in the blood, while in others death did not take place.

In the first group the most poisonous cultures were found to be

\* Beitr. z. Pathol. Anat. u. z. Allgem. Pathol., xii. pp. 433-93. See Centralbl. f. Bakteriol. u. Parasitenk., xv. (1894) pp. 761-4.

short streptococci, which occasionally formed the red pigment, and were originally obtained from tuberculous men.

**Streptococci in the Healthy and Unhealthy Mouth.\***—Dr. Dornberger records the results of 94 examinations of the mouths of children, both sick and healthy. In 45 per cent. streptococci were found in healthy children. In 78·9 per cent. of cases, *Streptococcus longus* was found. In angina phlegmonosa *Str. brevis* was found, and out of seven cases of angina catarrhalis, streptococci were present in five instances, while in chronic catarrhal angina these organisms were demonstrated in half the number of cases. In seven out of eight cases of carious teeth, long streptococci were found.

The frequent presence of cocci, which in form and arrangement resembled known pathogenic streptococci, both in morbid and healthy conditions of the mouth, suggested that both morphologically and biologically resemblances might present themselves between these organisms and *Str. pyogenes* or *erysipelatis*.

**Atmospheric Streptococci.†**—M. P. Chatin used for his experiments the Strauss and Wurtz apparatus, taking in at least 20 litres of air, or at most 70 litres. In two out of seven experiments, micro-organisms constantly present in the air developed: in one a non-virulent streptococcus; in one a virulent streptococcus which set up erysipelas; while the remaining three resulted in impure cultures, though they were found to produce an œdema in animals. In another series of experiments the air was taken from the operating theatre and the wards of a hospital. In this series plenty of germs developed, but none were pathogenic. The author particularly notes that streptococci thrive remarkably well in acid solutions.

**Transitory Variety of the Cholera Vibrio.‡**—During the last cholera epidemic at Rome Drs. A. Celli and S. Santori carefully examined forty-four cases, and in twelve instances found a vibrio with the following important characters. It does not give the indol reaction; is not pathogenic to animals; does not grow at 37° either in bouillon or on agar, nor does it coagulate milk. It is therefore probably an atypical form of the cholera bacillus analogous to those isolated by other observers from cholera dejecta.

The authors go on to say that eight months afterwards the foregoing negative characteristics disappeared, for the vibrio developed in bouillon and on agar, and gave the indol reaction. The pathogenic power, however, remained *nil*. They regard this organism as a transitory variety of *Vibrio cholerae asiaticæ* Koch, and point out that the bacteriological diagnosis of cholera is not always to be relied on.

**New Species of Choleroïd Vibrio.§**—Dr. M. Iwánoff describes a vibrio which was isolated from the intestinal evacuations of a patient suffering from enteric fever at the time when cholera was present in

\* Jahrb. f. Kinderheilkunde, xxxv. p. 395.

† Thèse, Lyon, 1893, 72 pp. See Centralbl. f. Bakteriologie u. Parasitenk., xv. (1894) p. 764.

‡ Centralbl. f. Bakteriologie u. Parasitenk., xv. (1894) pp. 789-95.

§ Zeitschr. f. Hygiene u. Infektionsk., xv. (1893) pp. 431-8. See Centralbl. f. Bakteriologie u. Parasitenk., xv. (1894) p. 433.



Berlin. From the cholera vibrio it is chiefly distinguished by its growth on gelatin and agar plates. In the first case, instead of the granulation occurring in about thirty-six hours, there is obvious mycele formation, while in the second the colonies have a whitish centre clearly visible with a hand-lens, the cholera colonies being quite transparent. A further criterion is to be found in the size of the new vibrio and its tendency to form spirilla. Products of 24-hour old agar cultivations killed guinea-pigs in 10–12 hours with symptoms like those of cholera intoxication. Pigeons, rats, and mice were refractory, but rabbits succumbed to a large dose.

**Cholera Bacillus and Tobacco.\***—Dr. Wernicke states that the cholera bacillus speedily perishes on tobacco-leaves, even when moist, and that therefore any danger of the spread of cholera from tobacco or cigars is but slight.

**Artificial Variation of the Cholera Vibrio.†**—Prof. E. Metchnikoff is of opinion that there are two types of vibrios which retain their peculiarities, both under natural and artificial conditions. The types, distinct enough in appearance, are short, curved vibrios (the comma bacillus type, in fact), and long, thin filaments, sometimes almost straight, sometimes twisted into spirals with several turns. The short and long vibrios are not two constant types, but simply form two races which may be transformed the one into the other, according to external circumstances. To turn the elongated vibrio into the squat shape, all that is necessary is to inoculate it on a guinea-pig and then make cultivations from the peritoneal exudation on agar, while in old cultivations the short vibrio will become a thin elongated organism. As a rule, however, these transformations have little stability and, to effect a durable change, the vibrios must be exposed for a long time to influences acting slowly. Like the shape, the virulence of the vibrio is liable to considerable variations, though the two are not necessarily connected; thus while a particular variety will retain its shape for a considerable period, its virulence is liable to undergo very notable variations. From a review of all the facts, it would seem impossible to deny that this case of the cholera vibrio might be cited as a striking example of pleomorphism, and hence its bacteriological diagnosis may present insuperable difficulties.

**Coli Group of Bacteria.‡**—Dr. H. de Stoecklin contributes an interesting memoir on the Coli group of organisms, and his conclusions are that (1) the term *Bact. coli commune* includes a group of intestinal bacteria, the predominating character of which is that they do not liquefy gelatin, and are not stainable by Gram's method; (2) the group includes both mobile and immobile species, about 2/5 of the whole being mobile; (3) when the species is mobile, the mobility is extreme, and never sluggish; (4) by means of Loeffler's method of staining cilia the Coli group is easily distinguishable from the bacillus of enteric fever.

\* Centralbl. f. Bakteriol. u. Parasitenk., xv. (1894) p. 898.

† Ann. Inst. Pasteur, viii. (1894) pp. 257–74.

‡ Ann. Suisses des Sciences Medicales, l. No. 6. See Ann. de Micrographie, vi. (1894) pp. 238–9.

The author also makes some interesting observations on the general morphology of this group. He has remarked, though only in the multiciliated species and never in the unciliated, the existence of a capsule in the centre of which the bacillus is seen. The cilia always proceed from the capsule, and seem to be of the same substance, and, as it were, a prolongation thereof. Often a single capsule contains two bacilli; the number of cilia is then doubled. The author inclines to the belief that the bacilli so called are really the nuclei of a cell. This cell is difficult to show properly, and hence the ordinary methods of staining only show the bacilli. The author has also remarked that the movements of the unciliated species are more rapid than those of the multiciliated.

**Bacterium coli commune in Living Blood.\***—Drs. Sittmann and Barnow record a case from the blood of which they isolated during life *Bacterium coli commune*. The median vein was punctured eleven hours before death, and cultivations made with the blood on agar and gelatin plates. Pure cultivations of an organism morphologically identical with *B. coli* were obtained. The same organism was cultivated from the urine. Inoculation experiments with the pure cultivations were made on rabbits, subcutaneous, intravenous, and intravesical. Only the intravenous injections were successful, the failures being ascribed to the variability of virulence of this organism. The case clinically was one of septicæmia after stricture of urethra, followed by cystitis, pneumonia, suppurative nephritis, and endocarditis.

**Ætiology of Malta Fever.†**—Surgeon Captain D. Bruce, in conducting an investigation into the nature of Malta fever, tried to establish the presence of a special micro-organism, by microscopical examination of the blood during life and tissues after death, and by making cultivations from the blood and other organs. Successful cultivations were made from spleen pulp, and in twelve out of thirteen cases the presence of the same micro-organism was demonstrated. The microbe of Malta fever is a coccus of about  $0.33 \mu$  diameter. It is easily stained by aqueous gentian-violet solution, but is decolorized by Gram. The best cultivation medium was found to be  $1\frac{1}{2}$  per cent. peptonized agar-beef-jelly. On gelatin the growth was slow, and there was no liquefaction of the medium. Inoculation experiments with pure cultivations of the coccus on animals were negative except in the case of monkeys. Out of four monkeys three died after inoculation, and from their viscera the micrococcus of Malta fever was cultivated.

The author concludes from his experiments that this disease is a specific fever, distinct from enteric or malaria, and that the coccus described is its proximate cause.

**Bacillus levans.‡**—Prof. K. B. Lehmann states that a bacterium which he has named *Bacillus levans* is to be found in the yeast used for making rye bread. It is a facultative anaerobe, and will grow in an atmosphere of  $\text{CO}_2$ . On gelatin plates a whitish deposit is formed, and

\* Deutsch. Arch. f. Klin. Med., lii. No. 4. See Centralbl. f. Bakteriologie u. Parasitenk., xv. (1894) pp. 694-5.

† Army Medical Department Report for 1890, App. 4, xxxii. (1892) p. 365.

‡ Centralbl. f. Bakteriologie u. Parasitenk., xv. (1894) pp. 350-4.

under a low magnification the colonies are seen to be finely granular, having a lightish margin and darker centre. In saccharated media (gelatin, agar, bouillon) gas is freely developed, about one-third of it being hydrogen and two-thirds carbonic acid. Microscopical examination showed that the organism was a rodlet of variable length possessed of considerable mobility and devoid of spores. A prominent feature was the production of acids, chiefly acetic and lactic, though traces of formic were discoverable. By inoculating sterilized meal with a pure cultivation of *B. levans*, active fermentation accompanied by rising of the dough and production of acid ensued. Besides the foregoing features *B. levans* has several characters in common with *B. coli commune*. Morphologically they resemble each other closely. They produce gases equally well though in different amounts, e.g. instead of one-third hydrogen and two-thirds carbonic acid, *B. coli* produces two-thirds hydrogen and one-third carbonic acid. The few experiments on animals show that *B. levans* possesses slight pathogenic properties, and recalls in this respect the effect of some races of *B. coli*.

**Microbe of Ozæna.\***—Dr. Loewenberg, who has studied this disease since 1880, states that he has constantly verified the presence of a large motionless coccus, mostly in pairs, and frequently in chains, held together by a hyaline mass. When stained with gentian-violet and examined under high powers they often show a transverse clear zone. The organism does not stain by Gram's method. As a rule the reaction is alkaline, and the microbe resembles in appearance Friedlaender's pneumobacillus. Cultivated on gelatin plates two sorts of colonies develop, one yellowish in the gelatin, others whitish on the surface. Both, however, are formed by the same microbe, a coccobacillus, which in artificial cultures may lose its capsule. The organism grows also on other media such as agar, bouillon, serum, potato, and even when cultivated anaerobically. In the disease condition the micro-organism gives rise to a very disagreeable smell, while in artificial cultivation the odour is agreeable. Preparations from nasal mucus and from blood of animals show a capsule, but in artificial cultures the presence of a capsule is very variable. Ribbert's solution stains the capsule, when present, admirably.

The coccus of ozæna, which is invariably present in the discharge in enormous numbers, can only be confounded with the pneumobacillus, but in artificial cultures they show important differences, those of ozæna on gelose being white, and those of pneumobacillus being yellowish. In sterilized milk the former scarcely grows at all, while the latter thrives well, coagulates and acidifies the medium. On gelose pneumobacillus gives off a strong odour of trimethylamin and imparts to the medium an alkaline reaction.

The microbe of ozæna is extremely pathogenic, and though pneumobacillus is so too, yet it is less virulent to mice.

**Anthrax in the Rabbit, and its Lessons.†**—M. Werigo, who has studied the development of anthrax in the rabbit, through microscopical examinations of the liver and spleen, discusses three principal questions in connection with this particular form of the malady, viz. the theory

\* Ann. Inst. Pasteur, viii. (1894) pp. 292-317. † Tom. cit., pp. 1-53 (3 pls.).



of phagocytosis, the part played by the spleen in infectious maladies, and the chemiotaxis of leucocytes. With regard to phagocytosis, it is pointed out that in the circulating blood only a few leucocytes with bacteria inside can possibly be present at any given time; that they remain in the circulation stream for a short time only, i. e. until they get transported to the liver. Hence they should be looked for in the liver. With regard to the second point the author puts forward an original view with some determination. The reason why bacteria are found in the spleen in infectious disease is that this organ is feebly phagocytic, and *per contra*, the liver being endowed with considerable destructive power, few micro-organisms are found therein. This conclusion of the author is deduced partly from the appearances observed by him in the liver and spleen of the animals experimented on by him, and partly from the consideration that the spleen being quite a small viscus would have little power or opportunity for exercising effective phagocytic functions. The liver, on the other hand, is large and highly vascular. With regard to the chemiotaxis of the leucocytes, the author throws over all idea of negative chemiotaxis; for him the phenomena are entirely positive; and if no future experiments should turn out favourably for negative chemiotaxis, then the theory of phagocytosis will have a still greater importance than at present.

**Manual of Bacteriology.\***—Dr. W. R. Dawson has translated Prof. S. L. Schenck's 'Grundriss der Bakteriologie,' and has brought it up to date with the author's assistance; it appears to be a work that will be found especially useful by independent workers who cannot obtain the larger systematic works.

**Bacteriology of the Plankton Expedition.†**—Herr B. Fischer gives the results of his observations on marine bacteria made during the recent Plankton Expedition. The methods of research are described in detail.

Except at very great depths, germs capable of germination were found everywhere in the ocean. The number in the Labrador, Florida, and Canary currents was larger than in the south equatorial, north equatorial, or Guinea currents. No bacteria could be detected with certainty in the bed of the ocean. They abound to a depth of 400 m., and are certainly present to a depth of 800–1100 m.

Mould-fungi (*Penicillium* and *Aspergillus*) were but rarely met with, but *Torula* and similar forms were much more abundant. The most common form of Schizomycete is the spiral; bacterium forms are also frequent; micrococci are rare. All the forms observed were endowed with motion resembling that of the cholera-vibrio; no formation of endogenous spores was observed. *Photobacterium Fischeri* exhibited, at one extremity, a tuft of long wavy cilia. The spiral form appears to be an adaptation to the fluid medium. A resemblance to the comma-bacillus is presented not only by their form, but also by their mode of growth. They differ, however, from it in their preference for a saline nutrient material. Most marine bacteria are aerobic, though some appear to be

\* 'Manual of Bacteriology,' 1893, 8vo, 324 pp., 100 figs. See Brit. Med. Journ., No. 1743 (1894) p. 1130.

† 'Die Bakterien d. Meeres nach d. Untersuchungen d. Plankton-Expedition, Kiel and Leipzig, 1894, 82 pp., 1 map and 3 figs.



also facultatively anaerobic. Some are able to resist a pressure amounting to 100 atmospheres. Some form pigments; a larger number are luminous in the dark; some of the latter are pathogenic to mice and guinea-pigs. The luminous forms were most commonly met with on the surface of living fish. There can be no question that marine bacteria are as important as the terrestrial forms in bringing about decomposition; but no evidence was obtained that they are pathogenic to marine animals, though it is most probable that they are so.

The following new species are described:—*Halibacterium polymorphum*, *H. rubrofusum*, *H. aurantiacum*, *H. purpureum*, *Photobacterium delgadense*, *P. degenerans*, *P. tuberosum*.

AGER, L. C.—A Peculiar Chromatogenic Bacillus.

*New York Med. Journ.*, 1894, p. 265.

ARNOULD, J.—Les nouveaux bacilles courbes des eaux. (New Curved Bacilli from Water.)

*Rev. d. Hygiène*, 1894, pp. 222-38.

BALL, M. V.—Essentials of Bacteriology.

2nd edition, London, 1894, 8vo, illustrated.

CRAMER, E.—Die Zusammensetzung der Sporen von *Penicillium glaucum* und ihre Beziehung zu der Widerstandsfähigkeit derselben gegen äussere Einflüsse. (The Composition of the Spores of *P. glaucum*, and its relation to the power of resistance to external influences which is possessed by them.)

*Arch. f. Hygiène*, XX. (1894) pp. 197-210.

D'ARSONVAL & CHARRIN—Influence des agents cosmiques (électricité, pression, lumière, froid, ozone, &c.) sur l'évolution de la cellule bactérienne. (Influence of Cosmic Agents (Electricity, Pressure, Light, Cold, Ozone, &c.) on the Development of the Bacterial Cell.)

*Arch. de Physiol.*, 1894, pp. 335-42.

DUCAMP & PLANCHON—Note sur le bacille fluorescent et liquéfiant des eaux d'alimentation de Montpellier. (Note on the Fluorescent and Liquefying Bacillus of the Drinking Waters of Montpellier.)

*Compt. Rend. Soc. Biol.*, 1894, pp. 266 and 7.

GUÉRIN, A.—Origine de la doctrine microbienne. (Origin of the Doctrine of Microbes.)

*Gaz. d. Hôpit.*, 1893, pp. 1259-61.

HANAUSEK, T. F.—Thermogene Bakterien als Erzeuger der Selbsterhitzung. (Thermogenous Bacteria as the Cause of Inflammation.)

*Zeitschr. f. Nahrungsmittel-Untersuchung*, 1894, pp. 15-6.

HEIM, L.—Lehrbuch der bakteriologischen Untersuchung und Diagnostik. Eine Anleitung zur Ausführung bakteriologischer Arbeit und zur Einrichtung bakteriologischer Arbeitstätten, mit zahlreichen, vielfach nach Original-Photogrammen hergestellten Abbildungen u. 8 Tafeln in Lichtdr., enth. 50 Photogramme von Mikroorganismen. (Bibliothek des Arztes.) (Text-book of Bacteriological Investigation and Diagnosis. An Introduction to Bacteriological Work and the arrangement of Laboratories, with numerous figures taken in many cases from original photographs, and eight photographic plates containing 50 photographs of micro-organisms.)

Stuttgart, 1894, large 8vo, xix. and 528 pp.

HERZ, FR. J.—Die Bedeutung der Bakteriologie für die Käsebereitung. (Bacteriology and Cheese-making.)

*Mitteil. d. Milchwirtsch. Vereins im Allgau*, Heft 5 (1894) pp. 133-57.

HÜNLEIN, F. H.—Bakterienstudien im Gebiete der Gerberei. (Bacterial Studies in Tanning.)

*Deutsche Gerber-Ztg.*, Nos. 18-23, 26, 29, 30, 32.

KERRY, R. E.—Ueber einen neuen pathogenen anaëroben Bacillus. (On a new Pathogenic Anaerobic Bacillus.)

*Zeitschr. f. Wissenschaftl. Veterinärkunde*, V. (1894) pp. 228-34.

- MALJEAN—Étude bactériologique de l'eau de la ville de Châlons-sur-Marne. (Bacteriological Study of the Water of the Town of Châlons-sur-Marne.)  
*Union Méd. du Nord-est*, Reims, 1893, pp. 265, 295.
- ROBERTSON, W. G. A.—Rate of Fermentation of Sugars.  
*Edinburgh Med. Journ.*, 1894, pp. 803-9.
- STUTZER, A.—Neue Vorrichtungen zum Sterilisieren von Milch, sowie zum Konservieren von Früchten und Gemüsen. (New Contrivances for Sterilizing Milk, and for the Preservation of Fruits and Vegetables.)  
*Deutsche Landwirtschaftl. Presse*, 1894, pp. 265-6.
- TEISSIER, P. J.—Étude des Propriétés chromogènes permanentes ou facultatives des certains microbes pathogènes ou saprophytes, cultivés sur l'albumine de l'œuf coagulé. (Study of the Permanent or Facultative Properties of certain Pathogenous or Saprophytic Microbes cultivated on coagulated Egg-albumen.)  
*Arch. Méd. Expér.*, 1894, pp. 315-27.
- VOLPE, L.—Microbi benefici e malefici. (Beneficent and Maleficent Microbes.)  
*Almanacco d. Giorn. d'Agricolt. l'Italia Agricola*, 1894.



MICROSCOPY.

a. Instruments, Accessories, &c.\*

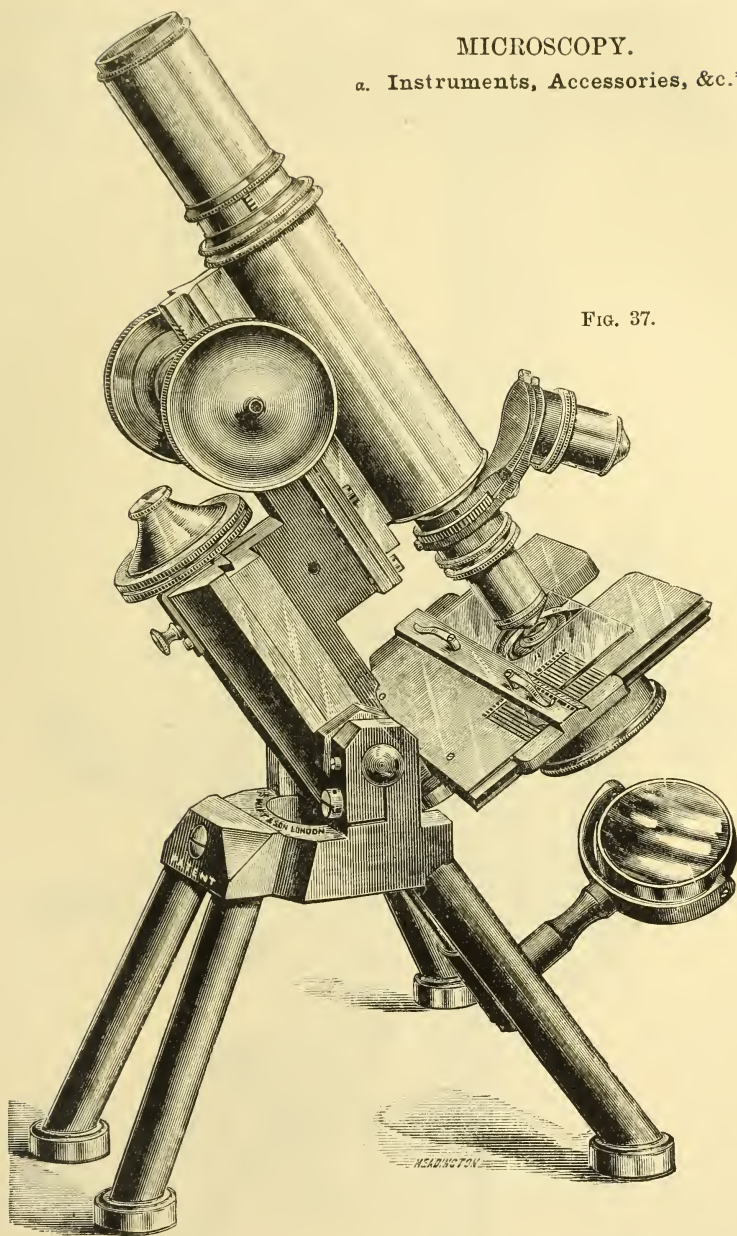

FIG. 37.

\* This subdivision contains (1) Stands; (2) Eye-pieces and Objectives; (3) Illuminating and other Apparatus; (4) Photomicrography; (5) Microscopical Optics and Manipulation; (6) Miscellaneous.

BEAUREGARD, H.—Le Microscope.

Paris, 1893, 12mo.

## (1) Stands.

Messrs. J. Swift's Four-legged Microscope. — We give two figures (37 and 38) of this Microscope which was described by Dr. W. H. Dallinger at the meeting of the Society in March last (see p. 285).

FIG. 38.

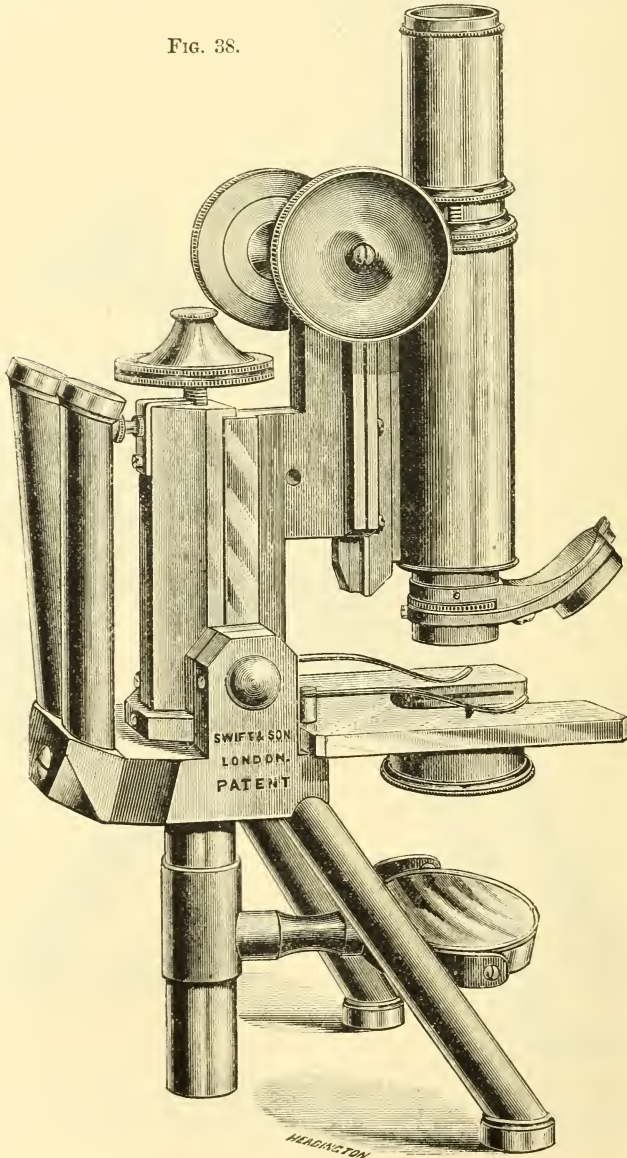



Messrs. Ross & Co.'s "Eclipse" Microscope.—The stand is mounted on a circular foot, the centre of gravity being so situated that steadiness is secured in every direction (fig. 39). To permit of the inclination

FIG. 39.

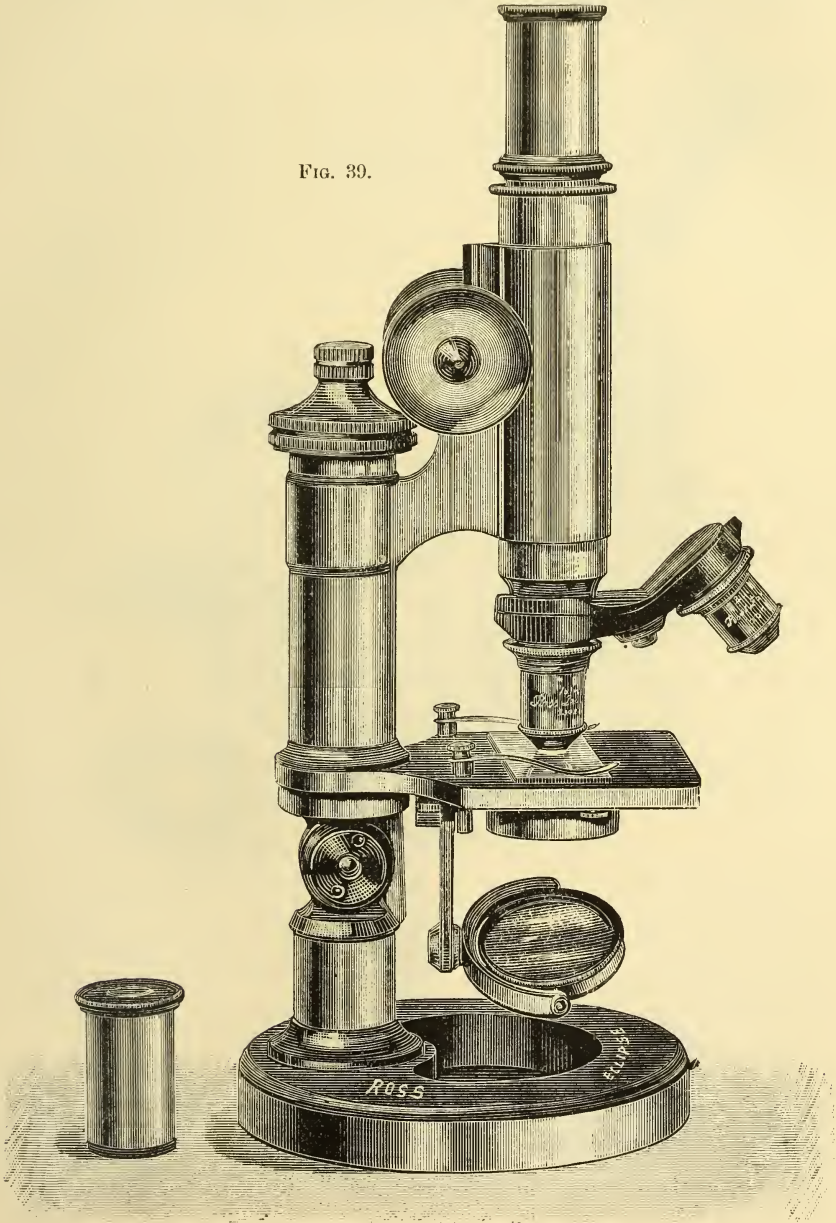

of the instrument it is provided with a knee-joint below the stage, and an arrangement has been designed by means of which the pillar rotates on the base, reversing the position of the stand on the foot (fig. 40) so that stability is maintained in all positions. The stage is firmly fixed and is not liable to flexure. The body-tube has the standard screw and

FIG. 40.

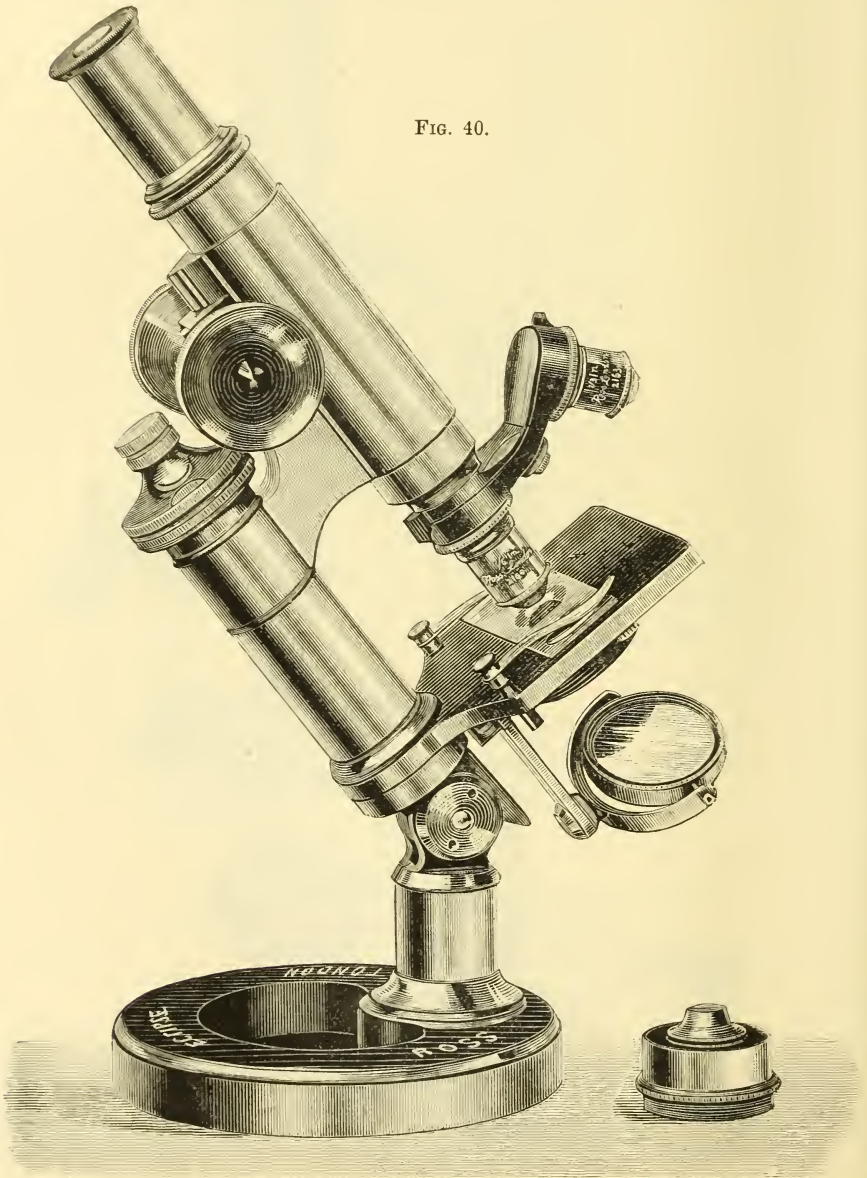

carries eye-pieces of the Continental size; it gives the optical tube-length of 160 mm., for which the object-glasses are adjusted, and is extended by means of a draw-tube to 200 mm. The fine-adjustment is sensitive and direct in action, and being independent of set-screws is not subject to derangement; its fitting is by a new contrivance completely covered at all points, and is thus preserved from injury by dust.

The instrument can be obtained in a rigid form, and with sliding tube instead of coarse-adjustment. A petrological stand is also made similar in size and form to the foregoing. It has a revolving circular stage divided to  $360^\circ$ . The analyser, which can be drawn out when not needed, is fitted into the lower end of the body-tube, where also a slot is cut at the angle of  $45^\circ$  for the insertion of the quartz wedge. The polarizer is pivoted to swing out of the field, it has a circle divided into eight and clicked at  $0^\circ$  and  $180^\circ$  to indicate when the nicols are crossed. The eye-piece is furnished with crossed webs.

FIG. 41.

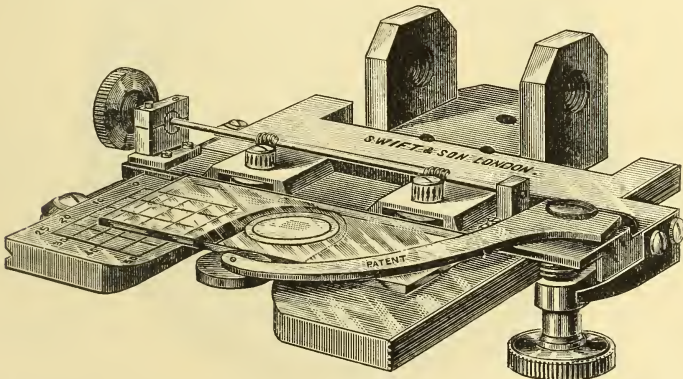

Messrs. J. Swift's new Mechanical Stage (fig. 41).—This stage was described by Dr. W. H. Dallinger at the meeting of the Society for June last (see p. 537).

#### (2) Eye-pieces and Objectives.

**New Objective Setting.\***—Dr. R. Steinheil has devised a new method of mounting the lenses of large objectives in their setting, by which the unequal expansion of the glass of the lenses and the brass or steel of the setting is compensated. The mode of compensation hitherto used in large objectives has been by means of a spring on one side of the setting, but this has the effect of destroying the centering of the objective owing to the unequal expansion of the crown and flint glass of the lenses. The author obviates this difficulty by placing between the glass and the setting small rods like the spokes of a wheel. In order that these rods may have the effect of equalizing the different expansions, the material of which they consist and their length must be settled by calculation

\* Zeitschr. f. Instrumentenk., xiv. (1894) pp. 170-3 (1 fig.).



from the coefficients of expansion of the glass of the lenses and the metal of the setting.

Now, considering only the linear expansion, a body of length  $l$  and coefficient of expansion  $a$  will increase in length  $l \cdot a \cdot t$  for a change of temperature of  $t^\circ$ . If then  $\gamma$  denote the coefficient of expansion of

FIG. 42.

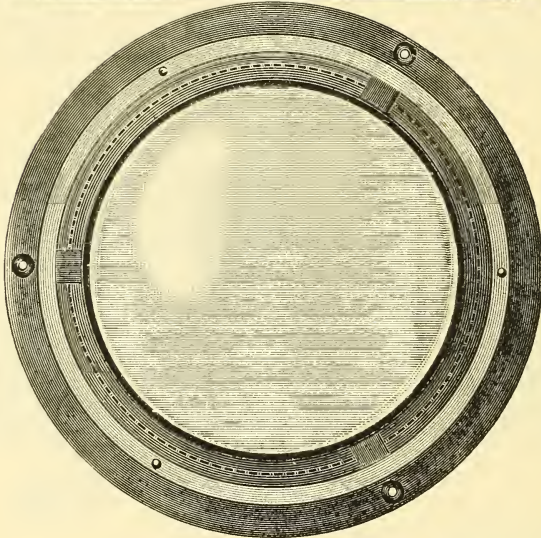
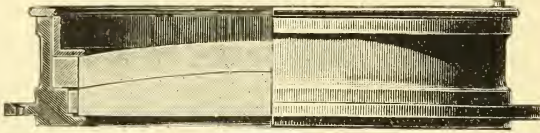

FIG. 43.

the glass,  $\phi$  that of the material of the setting, and  $\sigma$  the required coefficient of expansion of the rod whose length is equal to the difference of the radius of the setting  $\rho$  and that of the glass  $r$ , we have

$$\rho \cdot \phi \cdot t - r \cdot \gamma \cdot t = (\rho - r) \sigma \cdot t,$$

or

$$\sigma = \frac{\rho \phi - r \gamma}{\rho - r},$$

and for  $r = 1$ ,

$$\sigma = \frac{\rho \phi - \gamma}{\rho - 1}.$$

Putting  $\rho - 1 = l$ , the length of the rod, we have

$$\sigma = \frac{(l + 1) \phi - \gamma}{l} = \phi + \frac{\phi - \gamma}{l}.$$



For a determined length of the rods, this formula gives the coefficient of expansion of the rods and thus the material of which they are to consist. On the other hand, when written in the form

$$l = \frac{\phi - \gamma}{\sigma - \phi}$$

it gives for a determined material the length which must be given to the rods.

The formula shows that the rods can be so much shorter, the more nearly equal are the coefficients of expansion of glass and setting, and the more widely different those of the rods and setting. As an example the author takes the case of a large telescope objective of 50 cm. diameter, consisting of a flint glass lens with coefficient of expansion  $\gamma = 0.00000788$ , and crown glass lens with  $\gamma = 0.00000954$ . The setting was of cast iron, with  $\phi = 0.00001061$ , while the rods were of zinc with  $\sigma = 0.00002918$ .

For the flint, therefore,

$$l = \frac{1061 - 788}{2918 - 1061} = \frac{273}{1857} = 0.147.$$

The radius of the flint was however 25 cm., so that the rods for the lens had to be 3.675 cm. long.

For the crown,

$$l = \frac{1061 - 954}{1857} = \frac{107}{1857} = 0.05762,$$

and in this case the rods had to be 1.44 cm. long. The objective is seen in section and plan in the figure.

The widest internal diameter of the setting at the part where the flint lens lay was 57.35 cm., while the diameter of the part where the crown glass lay was 52.88 cm. It is quite sufficient if three rods only, separated 120° from each other, are placed between glass and setting.

### 3). Illuminating and other Apparatus.

**Hearson's Biological Gas Incubator** (fig. 44).—In this incubator the tank forming the water-jacket is made of stout copper, the outer case being of pine; the space between it and the water-jacket is filled with a non-conductor of heat. The chamber is closed with an inner glass door and an outer wooden one. All the mountings are of bright lacquered brass, and the wood is stained and varnished.

In the incubator, and immediately below the gas valve (fig. 45) which occupies the left-hand back top corner of the apparatus, is a small metallic hermetically sealed capsule, which contains a few drops of a liquid having a boiling point at or near the temperature at which the heated chamber is to be maintained.

The capsule lies in a little holder suspended below the tube, through which the needle under the screw P passes. Soldered to the upper side

of the capsule is a thick piece of metal, having a central depression. In this depression the lower end of the needle seen in fig. 45 rests, and the upper end of the said needle enters a short distance into the socket end of the screw P. Communication is thus established between the capsule inside and the valve outside.

A is the inlet for gas. C the outlet to burner. B D a lever pivoted

FIG. 44.

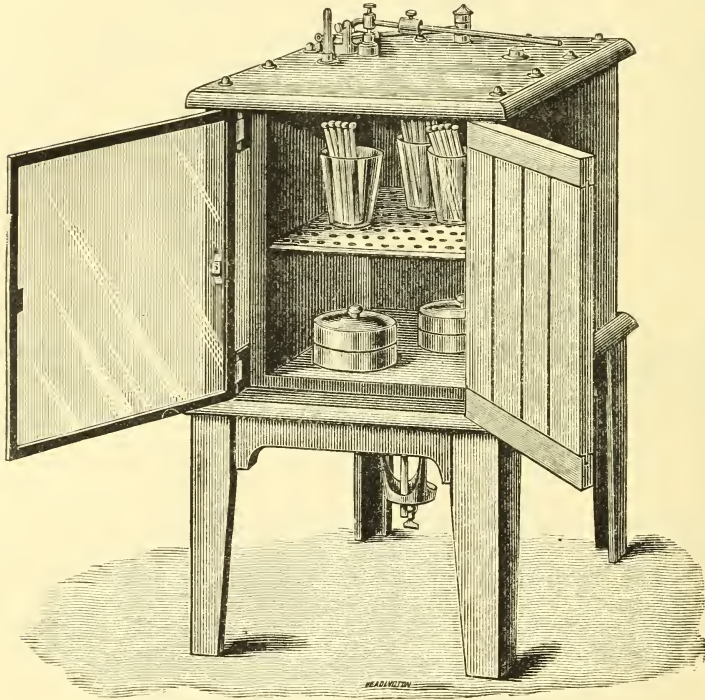

to standards at G, and acted upon by the capsule through the needle which enters the socket below the screw P. The construction of the acting portion of this valve is such that, whenever the end B of the lever B D presses on the disc below the end B, the main supply of gas is entirely cut off. At such times, however, a very small portion of gas passes from A to C, through an aperture inside the valve, the size of which aperture can be adjusted by the screw-needle S, hence the gas flame, which burns in a little lantern below the incubator, is never extinguished.

Changes in atmospheric pressure, however, tend to make the temperature fluctuate about a degree (Fahr.) on either side of the normal. To compensate for these variations, a sliding weight runs on the lever-rod D. But this weight serves a yet more important function. It gives the opportunity of retarding within certain limits the boiling point of

the capsule, and of thus adjusting the temperature at which the capsule shall expand several degrees above that at which it first commenced to

FIG. 45.

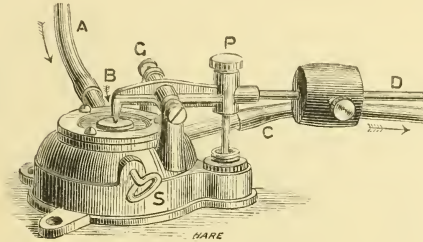

act. By this means a range of about  $8^{\circ}$  with any particular capsule is obtained.

**Hearson's Biological Incubator working with a Petroleum Lamp.**  
 —The outer case of this apparatus (fig. 46) is similar to the one already described, save only that the woodwork on the right-hand side is carried lower down to form a support for the lantern in which the lamp T burns. The general construction of the water-jacketed chamber is also the same; but there is a larger water-space below the chamber to make room for a pipe L, which leads the heated products from the flame through the water and back again to the lantern, the lantern being furnished with a second chimney which discharges into the open air a short distance behind the one seen in the illustration. A is the water-jacket surrounding the chamber containing the cultures. O is the pipe through which the water-jacket is filled with water. N is a cock for emptying the same. M is the overflow. S is the capsule contained in a case attached by a tube to the lever plate outside. D is a lever pivoted on the left, and carrying at its free end a damper F, which when resting on the chimney V effectually closes it. P is a screw for adjusting the damper when starting the apparatus. The end of this screw is concave, and into this concavity is inserted the upper end of a wire, the lower end of which rests on the capsule. H is a lead weight for bringing more or less pressure to bear on the capsule. K is the thermometer, the bulb of which is inside and the scale outside the heated chamber. The apparatus having been adjusted according to the instructions, the action is as follows;—The heated products of combustion, not being able to find any exit at the chimney V, pass along the flue L, and parting with the greater portion of their heat *en route*, return again to the lantern by a flue behind and parallel with the one seen in the section, and are thence conducted into the open air by a second chimney placed in the lantern a short distance behind the one covered by the damper F.

The products of combustion continue to move in this direction until the water and, consequently, the chamber are sufficiently heated to distend the capsule. When this point is reached the wire S and P will be pushed up by the capsule, and the lever will cause the damper to rise more or less off the chimney V. In a short time the damper



will be found to hang steadily in one position, and on examining the thermometer at intervals the inside of the chamber will be found to remain steadily at one temperature.

FIG. 46.

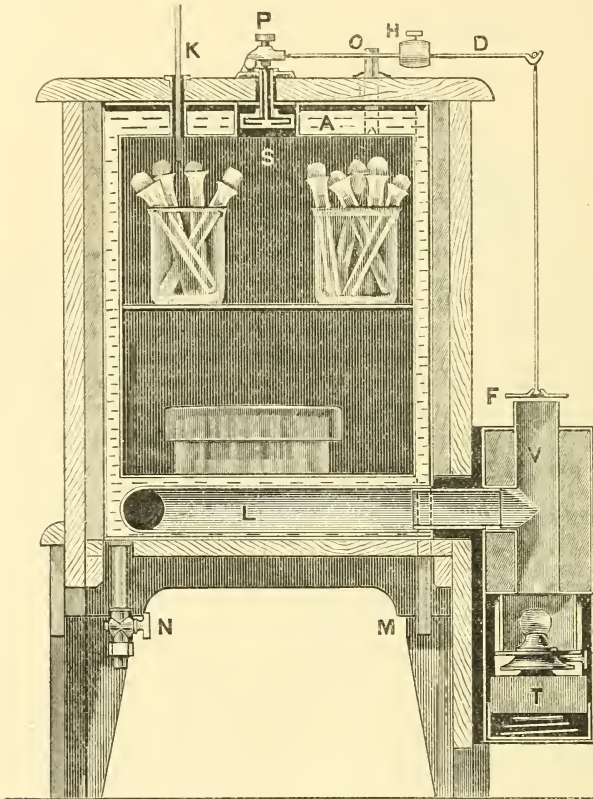

**Hearson's Patent Cool Biological Incubator for Gelatin Cultures**—This incubator consists of a water-jacketed chamber, surmounted by a vessel B (fig. 47) which contains ice, the whole apparatus being surrounded by a thick layer of non-conducting material and wood to protect it as far as possible from the effects of external influences. The regulation of temperature within the chamber is effected by a small stream of water which runs continuously through the apparatus in one of three directions, the choice being automatically determined by a thermostatic capsule. On the top of the apparatus is a lever plate and lever M, similar to the one used in the lamp incubator already described, only, in this case, the damper is dispensed with. A bracket screwed to this plate supports a vertical shaft, pivoted on centres at the top and bottom, which carries a horizontal tube C. In the incubating chamber is a capsule in a holder, supported by a tube screwed to the lever plate. A



stiff wire communicates the motion of the capsule to the lever M, and this lever is so connected with the tube C, that when the capsule expands the tube moves horizontally to the left. At the side of the apparatus is a lantern containing an open boiler F, heated by quite a small gas or petroleum lamp-flame. The bottom of the boiler is connected with the bottom of the water-jacket by a tube, so that the water in the boiler always stands at the same level as that in the water-jacket. The bottom of the ice vessel B has also an outlet which communicates with the water-jacket above the incubating chamber. The water-jacket is provided at the top with an overflow and waste-pipe at N, through which the surplus water escapes. The front end of the little tube C is bent downwards, and immediately under the bent end are two tubes D and E,

FIG. 47.

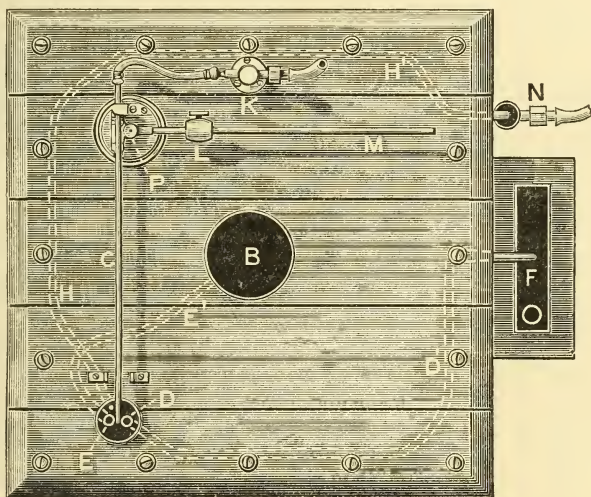

standing vertically side by side in an open vessel, with a short interval between them. The vertical tube E is connected with the top of the ice-box by a tube E', and the vertical tube D is connected with the boiler F by a tube D'. The valve K is connected on the right with a continuous water supply, and on the left by means of a small indiarubber tube with the small tube C. The apparatus having been adjusted according to the instructions, the action is as follows:—The stream of water passing the valve K, flows along the tube C, down the tube D, and along the tube D' to the boiler F, where it is heated, and thence flows into the water-jacket, and increases the temperature. After a time the capsule expands and moves the tube C to the left, thus causing the water to fall between the two tubes D and E. In this case the water is collected in the open vessel in which the tubes D and E stand, and is conducted by the pipe H H' to the waste-pipe N, without producing any effect whatever on the incubating chamber. If the temperature of the room in which the incubator is placed is above the boiling-point of the capsule,

the horizontal tube will continue to travel towards the left, so that presently the water will run down the tube E, along the tube E', and, passing through the ice-box, will so lower the inside temperature that the capsule will collapse a little, and cause the flowing water to again take up a position midway between the two tubes.

**Incubator for any Source of Heat.\***—This incubator, described by Dr. H. Reichenbach, is practically a copy of Hearson's. The only difference is the insertion of a pan to contain water on the floor of the incubator. This is intended to moisten the incubation air. The bottom of the incubator is perforated by a series of holes which can be closed by means of a damper. Through these holes the air enters, and passes through the water in the pan before it reaches the incubation space. The level of the water is kept constant by means of a funnel at the side of the incubator. This addition seems rather a complication than an improvement.

(4) Photomicrography.

**Apparatus for Obtaining Instantaneous Photomicrographs.**—The following is an account of the apparatus exhibited by Mr. C. Lees Curties on May 16th last. This instrument can be attached to any

FIG. 48.

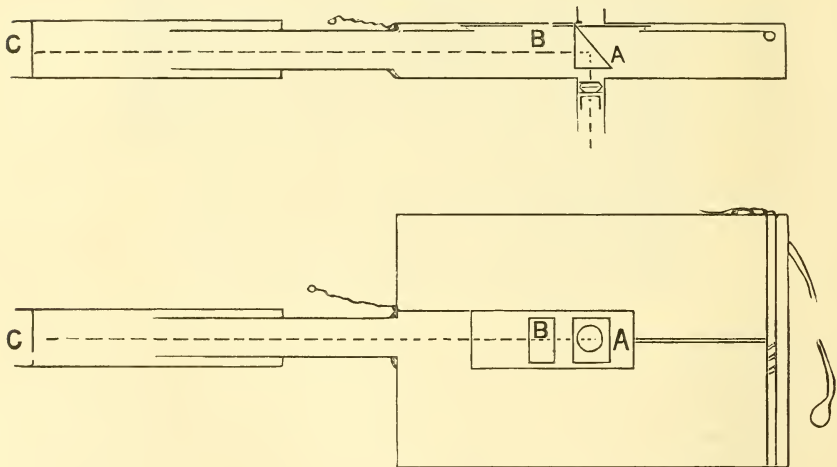

ordinary photomicrographic apparatus, whether horizontal or vertical, and consists essentially of an instantaneous pneumatic shutter, fitted with means of observing and focusing the object to be photographed until the moment of exposure. This is arranged by means of a prism A (fig. 48), mounted in front of the shutter aperture B, reflecting the image at right angles to a grey glass screen C, fitted in adjustable tube.

In using this instrument the shutter is half set, so that the image can be accurately focused in the plane of the sensitized plate. When

\* Centrallbl. f. Bakteriolog. u. Parasitenk., xv. (1894) pp. 847-50 (2 figs.).

full set, that is, the prism in the path of the optic axis, the image can be focused on the grey glass screen C, by means of the adjustable tube. As any variation of focus in the Microscope will affect both screens equally, all further observations can now be made on the screen C.

When the shutter is released the prism is carried out of position and the plate momentarily exposed as the shutter aperture crosses the optic axis, the length of exposure being regulated by the width of the shutter aperture, and also by fixing a fan to the pulley.

Human blood taken directly from the arm to the Microscope has been photographed by this apparatus, employing Zeiss apochromatic  $1/8$  objective N.A.  $\cdot 95$ , projection ocular 3, oxyhydrogen illumination, also living specimens of the Rotifera and freshwater animalcula taken with lower power objectives.

**Baker's Photographic Microscope.**—This instrument is made on the lines suggested by Mr. E. Hartley Turner, of Manchester, and consists of a solid brass base carrying body, stage, and sub-stage.

The body is 3 in. long by  $1\frac{1}{2}$  in. diameter, thus ensuring the passage of the whole of the rays emergent from even the lowest power objectives. It is fitted with universal adapter to carry micro-objectives,

FIG. 49.

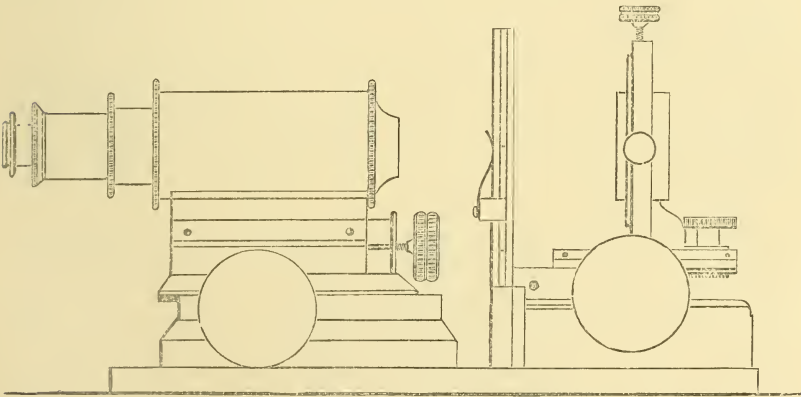

and its width of tube allows of ordinary short focus photographic lenses being used. Mechanical tube-length from 150 mm. to 270 mm. can be obtained by the use of draw-tubes. The fine-adjustment is of the Campbell differential screw form, and carries only the body, as in the large Nelson model Microscope.

The stage is fitted with sliding bar and removable spring clips, and has a clear aperture of 2 in., which can be reduced by diaphragms. The instrument can be fitted with mechanical stage if desired.

The sub-stage is of universal size, and is fitted with rackwork and centering screws; it has also a sliding adjustment, enabling condensers, differently mounted, to be brought within the limits of the rackwork movement.

All the fittings are sprung, and provided with adjustable screws to compensate for wear.

Lemardeley's Photographic Microscope.\*—This apparatus consists simply of an objective, a condenser, and stage for holding the preparation, all attached to a disc which is mounted directly upon the camera. It is thus a Microscope minus the illuminating mirror and tube carrying the eye-piece. The clips on the stage for holding the preparation are below instead of above, so that the preparation may be always placed in the same plane whatever the thickness of the cover-glass. The apparatus is provided with a system of automatic focusing for the use of those who are not familiar with the Microscope.

(5) Microscopical Optics and Manipulation.

A Suggested Method of Increasing the N.A. of Old Achromatic Object-glasses.†—Dr. Piffard, in a paper in the 'Medical Record' for March 24, calls attention to what he claims to be a "simple means of increasing the aperture and improving the performance of some immersion-lenses." He says, "About seventeen or eighteen years ago I purchased of Powell and Lealand a 1/4-in. water-immersion, rated by its makers as having an angular aperture of  $143^\circ$ . This would correspond to a numerical aperture of 1.26, and is, I believe, the highest aperture ever given to a water-immersion lens. Two or three years ago I discovered that it would work perfectly well with cedar-oil, which raised its aperture to N.A. 1.44.

More recently I have ascertained that, by closing the systems as far as the correction-collar would permit, and shortening the tube-length to about 155 mm., the objective would correct perfectly with monobromide of naphthalin. Not only was the over-correction introduced by the monobromide completely neutralized, but the character of the image remarkably improved.

I next investigated the possibility of error in the makers' statement as to the angular aperture, and found that with systems open and water contact the angle measured  $143^\circ$ ; with systems half closed and oil contact the angle was  $144^\circ$ ; and with systems entirely closed, using monobromide contact, the angle was also  $144^\circ$ . Applying the usual formula  $N.A. = n \sin u$  the result gave  $N.A. = 1.56$ , the highest aperture, so far as known to me, that has ever been obtained with an achromatic lens, working with crown-glass slides and covers. With the lens used in this manner I have resolved the *Amphipleura pellucida* on a dry mount, and this has been separately verified by my friend, Mr. H. C. Bennett, of this city. I mention this fact in order to show that the lens remained in a state of perfect correction, and stood up to the high eye-piecing which was needed to amplify the image to a point that would enable the resolution to be seen.

A duplicate of my lens and a Powell and Lealand 1/8-in. water-immersion N.A. 1.26, the property of Dr. William Stratford, were also found to work correct perfectly with the monobromide. A 1/6-in. oil-immersion N.A. 1.50 of the same makers failed to do so, possibly owing to insufficient range of adjustment.

Two American oil-immersion lenses of 1/10-in. equivalent focus,

\* English Mechanic, lix. (1894) pp. 383-4.

† Medical Record, xlv. (1894) pp. 362-4.



rated by their maker (Spencer) as having N.A. 1·32 and N.A. 1·38, were next tried with monobromide, and found to respond to it perfectly, it being necessary, as with the others, to close the systems and shorten the tube-length. I carefully measured the angular aperture of one of these with water, oil, and with monobromide; I found that its numerical aperture with water was 1·22; with oil, 1·39; and with monobromide, 1·51."

On this quotation it may, Dr. Dallinger remarked, be said that by the use of pure monochromes of the spectrum we can with our achromatic lenses get what is, in effect, a much larger N.A. than the monobromide will represent; and we do not despair of the ultimate use of such a monochrome as will bring the N.A. in practice up to 2·00, or even 2·20, and this will be done with media much more tolerant of organic tissues than the monobromide. Moreover, there is great uncertainty in the results obtained with this latter medium; it is very uncertain with different lenses presenting no normal reason for such difference; and we have in no case obtained what is in an eminent sense a "critical image."

**Researches on the Optical Properties of Wood.\***—M. C. Houliert describes the diffraction phenomena exhibited by thin sections of wood, and makes use of them in order to determine the dimensions of the fibres.

In thin tangential sections of wood the opaque walls of the fibres, disposed longitudinally, together with the alternating clear spaces in the interior of the fibres, constitute a system of lines which acts as a diffraction grating.

The following phenomena (fig. 50) are exhibited on looking at a vertical luminous slit across a thin tangential section of sideroxylon

FIG. 50.

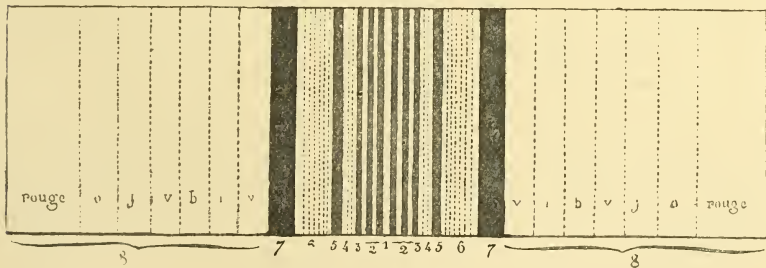

(*S. laurifolium*) placed in such a way that the axis of the fibres is parallel to that of the slit:—

- (1) The luminous slit appears very bright, with luminous bands to right and left, diminishing in brightness as they separate from the centre.
- (2) On each side of the central slit and separated from it by a black band, are two very narrow brilliant lines which represent really two very narrow spectra.
- (3) Next to these lines comes a black band of slight width.
- (4) A clearly visible, but narrow spectrum.
- (5) A black band.
- (6) A spectrum of appreciable width, in which all the fundamental

\* Rev. Gén. de Bot., xvi. (1894) pp. 49-50 (5 figs.).

colours can be clearly distinguished. (7) A black band, wide, but less intense than the preceding ones. (8) A very wide spectrum, of which about half the width is formed by the red colour. Beyond this spectrum comes a grey band of uniform colour.

Analogous results, varying only in the disposition or number of the images observed, are obtained with other kinds of wood. A tangential section of *Stillingia sebifera* (fig. 51) gives two fine spectra on each side of the central slit, but less wide than in the preceding case.

FIG. 51.

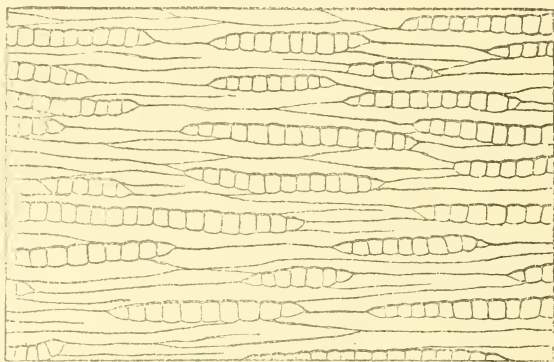

The well-known formula giving the intensity  $I$  of a monochromatic light of wave-length  $\lambda$  in a direction making an angle  $\delta$  with the direction of the rays falling on a grating is :

$$(1) \quad I = a^2 \frac{\sin^2 \frac{\pi a \sin \delta}{\lambda}}{\left(\frac{\pi a \sin \delta}{\lambda}\right)^2} \frac{\sin^2 \frac{n \pi (a + b) \sin \delta}{\lambda}}{\sin^2 \frac{\pi (a + b) \sin \delta}{\lambda}}$$

in which  $a$  represents the constant width of the transparent parts left between the lines of the grating (corresponding to the lumen of the fibres), and  $b$  the width of the opaque lines (corresponding to the thickness of the walls of the fibres);  $n$  is the total number of lines of the gratings.

The angle of deviation  $\delta$  of a monochromatic colour of wave-length  $\lambda$  is given by the relation

$$(2) \quad \delta = \frac{m \lambda}{a + b},$$

$m$  representing the number of order of the spectrum. Consequently the angle  $d$  enclosed between the directions of a simple colour belonging to two spectra of the same order, the one on the right and the other on the left of the central image, is given by

$$(3) \quad d = 2 \delta = \frac{2 m \lambda}{a + b}.$$

The author has applied the last formula to the calculation of the dimensions of the fibres. The section is mounted on a Babinet goniometer (fig. 52), and the angle  $2\delta$  measured for sodium light by means of the telescope.

FIG. 52.

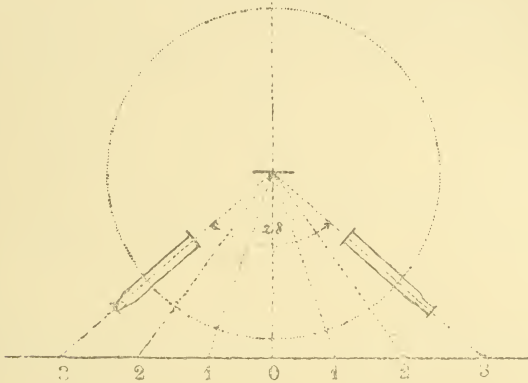

If a transverse section is taken instead of a tangential one, and a small circular aperture is observed across it instead of a narrow slit, phenomena of very brilliant coloured arcs are exhibited. The luminous circle is seen very clearly in the centre of the figure (O, fig. 53); on each

FIG. 53.

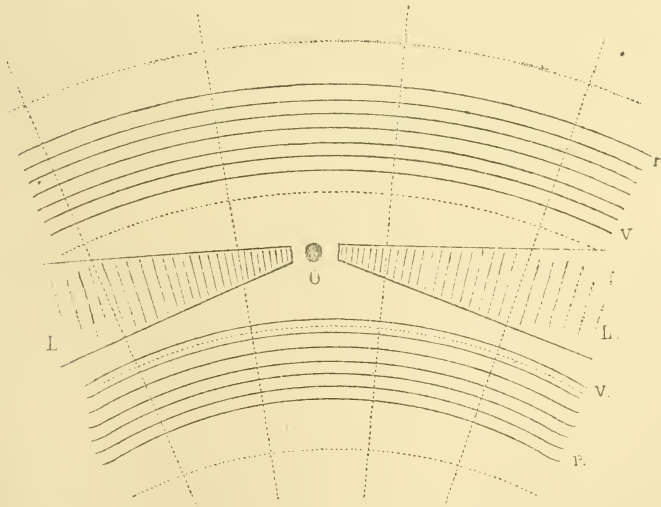

side, inclined in the direction of the layers of the wood, two luminous bands, which widen and become more coloured as they recede from the centre (L), are observed. Above and below these oblique bands, spectra

in concentric arcs are formed, having the violet inside and their concavity in the same direction as the annular layers.

The author describes the *erimeter*, or instrument devised by Young in order to compare the dimensions of organic powders. It depends upon the phenomenon of *crowns*, consisting of a zone of concentric coloured rings, exhibited when a luminous point is examined across a glass plate on which a fine powder is spread.

The instrument is formed of a divided scale C (fig. 54), to which are

FIG. 54.

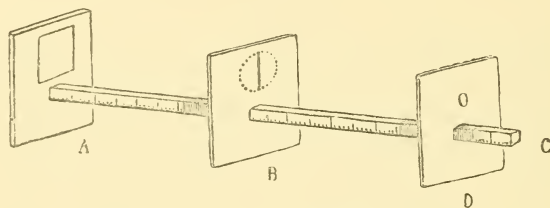

attached three vertical plates. On the plate A the powder to be examined is placed. The eye is applied to a small aperture O in the fixed screen D. At B is a screen carrying one or more circular series of holes, and a wide slit across which a part of all the rings formed by the powder is seen, when a luminous point is placed behind the plate A. The screen B is made to slide on the rule C in such a way that a ring of the same order coincides in all cases with one series of holes. The angular diameters of the rings are then between them as the distances of the screen B from the aperture O.

Upon the normal phenomena of spectra or of crowns produced by thin sections of wood are sometimes superposed phenomena of interference which complicate them. In the case, for example, when there is a great difference between the dimensions of the clear spaces and the opaque walls, interference fringes are superposed on the diffraction fringes; but, as these interference fringes are very brilliant, they are easily distinguished.

#### (6) Miscellaneous.

**Introduction to the Study of Microscopy.\***—Dr. E. Giltay's work is intended as an introduction to the study of microscopy, and the intention is carried out in a logical and systematic manner by means of a consideration of seven objects, the microscopical characters and peculiarities of each being described and explained, such as coloured objects, starch-grains, milk, air-bubbles, diffraction plate. The description of the objects is preceded by an introductory chapter explanatory of the parts of a compound Microscope.

**Micro-Chemistry.†**—Prof. H. Behrens' manual is the first general treatise on micro-chemistry which has appeared in the English language.

\* 'Sieben Objecte unter dem Mikroskop,' Leiden, 1893, 66 pp. and 8 pls.

† 'A Manual of Micro-Chemical Analysis.' By Prof. H. Behrens. With an introductory chapter by Prof. John W. Judd. London, Macmillan & Co., 1894. See Nature, l. (1894) pp. 122-3.



The first portion of the book treats of the suitable reactions and methods employed in the identification of the different elements. In the second part the author attempts to give a systematic scheme of examination, although at present a general scheme at all comparable with those used in ordinary analysis is impossible. The concluding portion of the work shows the application of the method to ores, alloys, rocks, &c.

“A Little Diversion from the daily cares often comes to those in active business life. Here are some trifles that have come to hand from time to time, which we will share with our readers.

One earnest student, on inspecting the Microscope which we then knew as the ‘Histological,’ inquired, having some familiarity with the name, whether this is the ‘Historic Microscope’?

Another—we think he was a ‘first-year man’—made careful inquiry whether we keep the binaural Microscopes? We do not; Microscopes have not yet reached this stage of development, but we make an excellent binocular, of beautiful adjustment, that we can highly recommend. . . .

Did you ever hear of a mythological Microscope? We did, once. Can it be a Microscope for the study of rock sections?

An ‘emersion’ objective surely must be a dry lens—what say the etymologists?

A daily paper speaks of the wonderful homogeneous inversion object-glasses.

Do our readers know of any objective powerful enough to ‘dissolve the striæ of *Amphipleura*’?”\*

“Some students may have the Leitz’s mechanical stage. The following directions copied from the American edition of Leitz’s ‘Catalogue of Microscopes and Accessories,’ published by Richards & Co., of New York, may enable them to apply the apparatus to their stands. ‘The screw on the right must be lost so, that the lever, of the form of an arc of a bow, can turn around the axis at which it is fixed on the left. Afterward, the stage is to be put on the stage of the Microscope so, that both angle pieces, opposite to the lever, drives the column of the stand; after putting the lever to its place, the screw gets fastened again. At last, the stage, must be fixed to column, by drawing close the other screw, being in the middle part of the lever.’”†

### B. Technique.‡

Zimmermann’s Botanical Micro-technique.§—Prof. J. E. Humphrey has published an English edition of this useful work, with notes. It is a complete handbook for the botanical laboratory, treating of the following subjects:—The observation of living plants and tissues, the investigation of dead plants, maceration, swelling, clearing, live staining, fixing and staining methods, and microtome technique.

\* Microscopical Bulletin, xi. (1894) pp. 9 and 10.

† Amer. Natural., xxviii. (1894) p. 550.

‡ This subdivision contains (1) Collecting Objects, including Culture Processes; (2) Preparing Objects; (3) Cutting, including Imbedding and Microtomes; (4) Staining and Injecting; (5) Mounting, including slides, preservative fluids, &c.; (6) Miscellaneous.

§ ‘Bot. Microtechnique,’ by Dr. A. Zimmermann. Translated by J. E. Humphrey, S.D., xii. and 296 pp. New York, 1893.

**Short Notes on Bacteriological Technique.\***—Prof. Miller calls attention to the following “tips” (*Kniffe*) which he has found useful in bacteriological work:—

(1) Cover-glass preparations may be satisfactorily dried by means of a dentist’s air-bellows. The drying may be accelerated by holding the nozzle of the bellows in the flame of a burner.

(2) Collection of condensation water on the cover of a Petri’s capsule by turning the capsule upside down in the incubator. Experience has shown that impurities do not arise more often by this procedure than on the usual one.

(3) After a streak cultivation on agar has been made, part of the plate may be covered with a thin layer of agar so that deep and superficial growths may be simultaneously observed. This device is specially useful for photographic purposes, as the deep and superficial growths lie on the same plane.

(4) Fungus-spores in capsules or test-tubes may be destroyed by putting a little calcium chloride on the agar surface and then pouring over it some hydrochloric acid. After this the culture is closed. The spores are killed in a few seconds.

(5) When mice are inoculated they should be narcotized with ether. Take the mouse by the scruff of the neck and the root of the tail and hold it over a Florence flask which contains some ether. (A little practice is necessary for this.) The mouse is anaesthetized in 20–30 seconds and inoculation is much more easily effected than by the aid of any fastening arrangement. Besides this the mouse does not feel the pain, a point always to be considered. Etherization is also extremely useful for examining the character of inflammatory products after inoculation.

**Bacteriological Technique.†**—Drs. Acosta and Grande Rossi have found that they can leave vessels containing nutrient media and needles uncovered without impairing their sterility for  $1\frac{1}{2}$  minutes. In two minutes only one test-tube, and that inverted, remained uninfected, and from  $2\frac{1}{2}$ –3 minutes nothing remained sterile.

(1) Collecting Objects, including Culture Processes.‡

**New Method of Preparing Culture Media.‡**—Dr. J. Lorrain Smith points out the difficulty bacteriologists have to contend with in the fact that the composition of many of the media used for cultivations of pathogenic microbes differs so widely from that of the blood and other fluids found in the animal tissues. He describes a method by which media can be prepared directly from these fluids by a process which reduces the difficulties of manipulation to a minimum.

Break up the white of a hen’s egg with an egg-beater till it loses its consistency; add 40 per cent. of water and mix well; pass the mixture through muslin to remove any shreds of insoluble material; add 0.1 per cent. of caustic soda, and solidify in the autoclave. With a little care in clearing it a jelly of egg-white can be obtained which closely

\* Centrallbl. f. Bakteriol. u. Parasitenk., xv. (1894) pp. 894–5.

† Crónica Médico-quirúrgica de la Habana, 1893, No. 16. See Centrallbl. f. Bakteriol. u. Parasitenk., xv. (1894) p. 876.

‡ Brit. Med. Journ., No. 1744 (1894) p. 1177.

resembles gelatin in consistency. Substances like glucose can be added if desired.

A large variety of bacteria have been found to grow on this medium with great readiness.

**Non-albuminous Cultivation Media for Vibrios.\***—Dr. A. Maassen recommends that vibrios be cultivated in a normal medium, one made up according to definite rules. The composition of the normal solution is as follows:—7 gm. of malic acid are dissolved in about 100 ccm. of H<sub>2</sub>O and neutralized with pure KHO. The solution is diluted with distilled water up to 1 litre, and then there are added 10 gm. finely powdered asparagin, 0.4 gm. magnesium sulphate, 2.0 gm. biphosphate of soda, and 2.5 gm. of pure crystalline soda. When the whole of these ingredients are properly dissolved 0.01 gm. of dry calcium chloride is added.

In this solution the malic acid can be replaced by equivalent quantities of other organic acids suitable as nutrient material, the potash by soda, the asparagin by an ammonia salt of an organic or inorganic acid, by various other nitrogenous organic substances, amides, amido-acids, urea, kreatin; the soda may be diminished and the quantity of water increased. Moreover, to this normal solution in its simple or varied form other assimilable carbohydrate compounds may be added, e. g. mannit, or other kinds of sugar, ethylen-glycol, glycerin, or dextrin.

In such nutrient solutions with variable amounts of cane-sugar, milk-sugar, maltose, galactose, grape-sugar, or dextrin, scum-forming vibrios develop luxuriantly, forming a thick membranous scum in 24 hours. The scum in a few days becomes puckered, and the fluid, at first as clear as water, turns yellow or yellowish-brown, the reaction altering just as it does in sugar-serum-bouillon. When pepton is added the production of indol occurs after the recurrence of the alkaline reaction. In non-albuminous solutions luminous vibrios develop luminosity in 18 hours.

**The Bujwid Reaction and Bouillon Cultivations.†**—Dr. Inghilleri finds that some micro-organisms are capable of living in bouillon in which cholera bacilli have been previously cultivated and which gives the nitroso-indol reaction very clearly. Their behaviour is, however, not the same, since they act differently on the inorganic combinations of nitrogen; for example, while some develop without modifying the Bujwid reaction, others destroy it. This is specially frequent with the bacilli of the alimentary canal, e. g. *B. coli commune*, which reduces nitrates to ammonia and other combinations of nitrogen. The indol is, however, undecomposed, and in the *B. coli* cultures it actually increases so that it is always possible to demonstrate its presence by means of Kitasato's reaction.

If *B. coli* or *B. typhosus* be cultivated along with cholera bacillus on meat-pepton solution, then the fluid shows, instead of Bujwid's reaction, only that of Kitasato. In this way an important diagnostic criterion of cholera is lost, and this should be borne in mind in reference to bacteriological examination of suspected cholera stools, for notwith-

\* Arb. a. d. Kaiserl. Gesundheitsamte, ix. (1894) pp. 401-4. See Centrallbl. f. Bakteriol. u. Parasitenk., xv. (1894) pp. 922-3.

† Centrallbl. f. Bakteriol. u. Parasitenk., xv. (1894) p. 688-9.

standing the presence of cholera bacillus the nitroso-indol reaction may fail if microbes capable of reducing nitrates be present in the stools.

**Cultivating Influenza Bacillus.\***—Dr. Huber, who has examined twenty cases, recommends blood-agar in preference to hæmatogen-agar, as the bacilli grow less vigorously on the latter, and also because puncture cultivations are possible with it. The chief property of hæmoglobin which renders it valuable for cultivating the influenza colonies is that it contains iron, and not because it is a carrier of oxygen. The bacillus can also be cultivated on hæmatogen-bouillon, while the presence of caustic soda was found to be unsuitable.

**Growing and Examining Bacterium Zopfii.†**—In their experiments Drs. R. Boyce and A. E. Evans employed 10 per cent. gelatin with neutral or faintly alkaline reaction, though there was no appreciable difference in the growth when the reaction was slightly acid. The method of cultivation consists in placing a small piece of moist cotton-wool in the bottom of a test-tube large enough to hold the ordinary 1 by 3 in. slide. The test-tube is plugged and the whole steam-sterilized at 120° for 20 minutes. When cool, a thin uniform layer of sterilized gelatin is spread over the slide, kept in horizontal position, by means of the Pasteur balloon pipette. The test-tube is then plugged and capped to prevent drying. When a streak culture has been made and it is desired to examine the growth, the slide is removed and placed in slightly diluted spirit for a few hours to fix the growth and extract the salts. The slide is then carefully dried, stained by Gram's method, and mounted in balsam.

Ordinary test-tube growths may be examined microscopically *in situ* by just warming the test-tube sufficiently to set the gelatin free, and then sliding it off on to a glass plate. A cover-glass is then put on and the growth examined. The best temperature was found to be about 21° C., which in 24 hours gave a perfect growth; this might be hastened if the back of the gelatin were painted black.

**Cultivating Cholera on Eggs.‡**—Herr Zenthöfer finds that when pure cultivations of cholera bacilli are grown on eggs there is no evidence of the development of H<sub>2</sub>S, the yolk preserving its normal honey-like colour, while the white becomes cloudy and liquefied. When H<sub>2</sub>S was demonstrable in any quantity its presence was found to be due to the impurity of the cultivation, the other bacteria predominating over the cholera bacilli. The eggs used were purified by leaving them for more than an hour in a 1-1000 solution of sublimate, a procedure which possibly exerted some slight inhibitory effect on the growth. Some of the cultures were anaerobic, and were grown in an atmosphere of hydrogen.

**Plate Diagnosis of Cholera.§**—Dr. Elsner adds to 1 litre water 250 grm. gelatin, 10 grm. Liebig's extract, 10 grm. pepton, and 5 grm.

\* Zeitschr. f. Hygiene u. Infektionskr., xv. (1893) pp. 954-9. See Centralbl. f. Bakteriol. u. Parasitenk., xv. (1894) p. 439.

† Proc. Roy. Soc., liv. (1894) pp. 300-12 (2 pls.).

‡ Zeitschr. f. Hygiene u. Infektionskr., xvi. pp. 362-7. See Centralbl. f. Bakteriol. u. Parasitenk., xv. (1894) p. 752.

§ Hygienische Rundschau, 1894, No. 7. See Centralbl. f. Bakteriol. u. Parasitenk., xv. (1894) p. 877.



salt, and then heats the mixture in a water-bath at  $50^{\circ}$  until the ingredients have dissolved. The mixture is then neutralised with soda solution until it has a clearly alkaline reaction, whereupon the white of an egg is added and the whole strongly shaken. The solution is next steam sterilized at  $100^{\circ}$  for one hour, and afterwards hot-filtered. The filtrate, having been distributed in test-tubes, is steam sterilized on three consecutive days for 16 minutes. This 25 per cent. gelatin remains firm up to  $30^{\circ}$  C. When plates are inoculated with cholera and incubated at  $27^{\circ}\cdot5$ – $28^{\circ}$  the colonies attain in 9–10 hours the same size as when grown on 10 per cent. gelatin at  $21^{\circ}$  in two days.

**Examining Water for Anaerobic Bacteria.\***—Herr G. P. Drossbach finds that the absorption method of cultivating anaerobes may be successfully carried out in the following manner. Petri's capsules uncovered are placed on wire triangles and piled up one over another in an exsiccator, the floor of which is covered with some substance eagerly absorbent of oxygen. The author uses iron protoxide or chromium acetate. In using the former the floor of the exsiccator is covered with a layer, 1–2 cm. high, of caustic soda, upon which an equivalent quantity of iron chloride solution is deposited. The lid having been imposed the two fluids are mixed by just turning the exsiccator round and round.

Chromium acetate acts still more energetically than iron oxide as an oxygen absorbent. In this case instead of caustic soda a saturated solution of sodium acetate is used. Upon this an unfiltered saturated solution of chromium sesquichloride is deposited. This solution is previously reduced to a blue colour with  $Zn + HCl$ .

**Experiments as to Vitality of Anthrax Spores in Earth and Water.†**—Drs. S. Sirena and G. Scagliosi record some facts relative to the vitality of anthrax in earth, in sea, drinking and drain water. These media were used sterilized and unsterilized, and kept at rest and in motion. It was found that anthrax spores were alive and retained their virulence in distilled water for over 20 months; in earth, moist, dry, or covered with water, for over 2 years and 9 months; in sea-water for 1 year and 7 months; in drinking-water and in sterilized sea-water for 17 months; in drain-water for nearly 16 months; and in a decomposing spleen for more than 2 years. It would seem that the media in which the anthrax has lived has some influence on the virulence of the organism.

**Microbicidal Action of Gallanol.‡**—MM. Cazeneuve and Et. and N. Rodet have made experiments relative to the effect of gallanol on the vitality and pathogenicity of bacteria. The organisms used were *B. anthracis*, *Staphylococcus aureus*, *Pyocyanus*, *Bacillus typhosus*, and *Bacterium coli commune*. They mixed gallanol in various proportions with nutrient bouillon (5–10 per cent. and 0·1 and 0·02 per cent.). Cultivations of the above-mentioned bacteria were quite killed in a short

\* Chemikerzeitung, xvii. (1893) p. 1483. See Centrabl. f. Bakteriologie u. Parasitenk., xv. (1894) pp. 775–6.

† Centrabl. f. Bakteriologie u. Parasitenk., xv. (1894) p. 952.

‡ Lyon Médicale, 1893, No. 45. See Centrabl. f. Bakteriologie u. Parasitenk., xv. (1894) pp. 574–5.

time in the 5-10 per cent. mixture. In the 0.1 per cent. the typhoid bacilli were killed. While *St. aureus* was weakened *Pyocyaneus* and *B. coli* were unaffected. The 0.02 per cent. gallanol bouillon had no effect. Experiments on rabbits and guinea-pigs inoculated with 5-10 per cent. gallanol cultivations, confirmed the death of the micro-organisms and showed that the medium was harmless. Inoculations with 0.02 per cent. gallanol bouillon showed that the vitality of the microbes was unaffected, though their virulence was diminished. On account of its harmlessness the authors recommend gallanol for parasitic skin diseases.

**Testing Resistance of Bacterium coli commune to Drying.\***—Dr. H. Walliczek has made a series of experiments relative to the resistance of *Bacterium coli commune* to drying.

(1) As control experiments pieces of filter-paper saturated with bacterial cultivations were placed for 5 minutes in sterile water, and then sown in gelatin tubes. Many thousands of colonies grew up.

(2) Infected pieces of paper were dried in vacuo by means of the air-pump. This took about 30 minutes. Thereupon they were placed in sterile water for 5 minutes and afterwards in gelatin. In a series of four, 6, 11, 17, and 58 colonies developed.

(3) Pieces of paper were dried under the air-pump, the tap remaining open so that fresh air was constantly aspirated. They dried in 45 minutes. 0, 28, 45, 78, and more than 1000 colonies grew up.

(4) Pieces of filter paper were placed in a sterile capsule. All were dry in 18 hours. 0, 0, 0, 0, 0 developed.

(5) Infected papers were dried in an exsiccator over sulphuric acid. All were dry in 17 hours. 0, 0, 1, 10, and 25 colonies grew.

The author concludes from the foregoing experiments that *B. coli commune* is killed by drying.

**Method for Inoculating Gelatin Plates.†**—Dr. W. Kruse finds that the most practical and successful way of inoculating gelatin plates is to brush them over with an ordinary camel's-hair brush dipped in the fluid to be examined. The procedure is of great use when examining water for typhoid bacilli, but it has been successfully used for demonstrating diphtheria and influenza bacilli, various streptococci, and Gonococcus. (It might be cheaper and safer to use strips of sterilized blotting paper.)

**Technique of Disinfection Experiments.‡**—Dr. H. Walliczek, after pointing out the disadvantages of silk, filter and cover-glasses as recipients of bacteria in disinfection experiments, suggests the use of material made out of glass-wool. Such a substratum would allow of the equal distribution of the bacteria, the disinfectant could be easily removed, and would offer a suitable surface upon which the infection-material could be properly disposed, and that too without drying. In default of the general adoption of glass-wool for disinfection experiments, he suggests that the following rules should be adhered to. If the bacteria are resistant to drying and no indifferent medium is known which paralyses the action of the disinfectant, then cover-glasses should be

\* Centralbl. f. Bakteriologie u. Parasitenk., xv. (1894) pp. 949-50.

† Tom. cit., pp. 419-21.

‡ Tom. cit., pp. 947-9.

used for the distribution of the bacteria, and the bacteria should be dried on. If an indifferent medium be known which stops the action of the disinfectant, it is advantageous to use filter-paper, and not to dry the bacteria. If cover-glasses be used the material should be previously dried on in order to prevent it from being washed off unequally.

When the bacteria are not resistant to drying, and no indifferent medium is known, cover-glasses should be used and the material not dried. If a paralyzing agent be known then filter-paper should be chosen and drying avoided.

As a substitute for cover-glasses and filter-paper the author has used thin layers, leaves in fact, of gelatin, in order to obtain a regular dissemination of the material. This procedure is, however, not of universal application.

**Modification of Wolffhügel's Colony Counter.\***—Dr. G. Mie has devised an improvement of the usually adopted counter, the modification of which consists in making the under plate the counter, and using a simple glass plate as cover. The distance between the counting plate and the gelatin is thereby much diminished.

**Distribution of Bacteria Colonies in Esmarch's Roll Tubes.†**—Dr. B. Körber points out that calculations based on observations of cultivations in Esmarch's tubes are often erroneous, the chief sources of error being that the internal diameter of the tubes is not the same throughout; the section is often not circular but oval, and all tubes have a turn on their long axis.

**Combination Hot Filter and Steam Sterilizer.‡**—Mr. F. W. Mally recommends that agar and other solid media should be filtered hot in a steam sterilizer, as thereby filtration is facilitated and a germless filtrate produced. A sort of diaphragm with a central hole is placed inside the sterilizer, and on this is fitted a structure 8 in. high, and having a handle at one side. Herein is placed a hollow cone, the upper diameter of which is 4 in., and that of the lower  $2\frac{1}{2}$  in. For the top a lid is provided.

Besides the conical funnel, there is a thermometer attached, and the whole is surrounded like the sterilizer with asbestos. The fluid to be filtered is placed inside the sterilizer, and an empty flask of equal size as well. The funnel receives a filter paper, and when sufficiently damped by the moist heat of the sterilizer the contents of the first flask are poured into the funnel and filter into the empty one which has been placed below.

**Chamberland Filter Système André.§**—M. Lacour-Eymard has examined the working of the Chamberland-Pasteur filter système André. This system adapts to the porcelain bougie a layer of an indifferent powder, "poudre d'entretien," in such a way that dirt is prevented from

\* Hygienische Rundschau, 1894, No. 7. See Centralbl. f. Bakteriologie u. Parasitenk., xv. (1894) p. 876.

† Zeitschr. f. Hygiene, xvi. p. 513. See Centralbl. f. Bakteriologie u. Parasitenk., xv. (1894) pp. 921-2.

‡ Modern Medicine and Bacteriological World, 1893, p. 275. See Centralbl. f. Bakteriologie u. Parasitenk., xv. (1894) pp. 877-8.

§ Rev. d'Hygiène et de Pol. San., 1893, No. 6. See Centralbl. f. Bakteriologie u. Parasitenk., xv. (1894) p. 621.

clogging the filter, which can thus be mechanically cleaned more easily. The author finds that the use of this powder in no way alters the chemical composition of the water, only absorbs about one-tenth of the gases dissolved in the water, and has no influence on the bacteria therein.

The filter will continue to deliver germless water for quite 10 days, provided the pressure be not more than 1 or 2 atmospheres, which the André regulator provides for. The filter should be sterilized every 10 days or oftener, and this is better done by means of alcohol or alum than by heat.

**Natural Pure Cultivations of Skin Fungi.\***—Dr. P. G. Unna procures scales and crusts which he wishes to examine, by pressing on the diseased portions of skin zinc plaster-mull for some minutes, so that on removal the scabs adhere to it. They are then placed first in benzin and afterwards in hydrochloric acid alcohol, by which they are freed from the plaster. The pieces are then placed on a slide and stained for 15 minutes in strong anilin-water gentian-violet solution. They are next dried and treated for two or three minutes with an iodine solution (5 per cent. iodide of potassium and peroxide of hydrogen solution, of each equal volumes). After this they are again dried, and thereupon immersed for 2 to 12 hours in picro or eosin-anilin.

**Demonstrating Sulphuretted Hydrogen generated by Bacteria.†**—M. Orłowski availed himself of Fromme's method for demonstrating the disengagement of  $H_2S$  by bacteria, the basis of which method is the presence of a metallic salt in the medium; thus Fromme added to peptonized gelatin 3 per cent. of tartrate or saccharate of iron, and cultivated thereon very successfully bacteria of anthrax and typhoid fever, the medium being stained black owing to the development of  $H_2S$ .

The author extended the research in two directions by observations on a large number of different species, and by the use of several kinds of chemical substances. To the ordinary cultivation media (gelatin was chiefly used) the chloride or sulphate of iron, the lactate, sulphate, or acetate of copper, the iodide or basic acetate of lead, and also the nitro-prussiate of soda were added. On media of the foregoing composition, numerous different species of organisms were cultivated with the result that while the copper salts strongly retarded growth, the iron, lead, and nitro-prussiate in no way interfered with it.

*Bacillus typhosus*, *B. coli commune*, *B. neapolitanus*, and bacillus of malignant œdema generate sulphuretted hydrogen as is shown by the discoloration of the medium containing iron. *B. typhosus* gives the strongest evidence, the medium along the track being quite black from the second day. On the nitro-prussiate gelatin the positions are reversed, for *B. typhosus* imparts only a faint blue colour at the end of the track, while with *B. coli* and malignant œdema the colour is deep or bright blue. With lead salts the results were similar to those for iron, a deep black stain along the inoculation track with *B. typhosus* on the second day.

\* Monatshefte f. Prakt. Dermatol., 1894, No. 6. See Centralbl. f. Bakteriol. u. Parasitenk., xv. (1894) pp. 701-2.

† Wratsch, 1893, No. 48. See Ann. de Micrographie, vi. (1894) pp. 120-2.



Copper salts produce a faint red coloration of the medium.

Cultivations from "typhoid" stools by this method showed deep black discoloration of the medium, and in Petri's capsules each colony was stained black, and without liquefaction of the gelatin.

(2) Preparing Objects.

**Examination of Eggs of *Limax maximus*.**\*—Mr. F. L. Washburn found the most satisfactory procedure was to quickly open the body-cavity of a laying slug, and placing the animal for one minute into a boiling hot solution of corrosive sublimate; then to transfer to water, remove eggs from oviduct, and shell them. The vitellus was allowed to remain in distilled water 2 minutes, then transferred to 35 per cent. and 50 per cent. alcohol for 3 minutes each, and then permanently preserved in 70 per cent. alcohol. For examination of eggs *in toto*, Czokor's alum-cochineal gave, as a rule, good results. Picrocarminate of lithium was also found to be excellent, on account of its differentiating nuclear structures. For section staining on slide, safranin was used for  $2\frac{1}{2}$  minutes followed by acid ( $1/2$  per cent. hydrochloric) alcohol of 90 per cent. for 7 to 10 minutes.

Freshly laid eggs placed for 5 minutes in Fol 99 (1 per cent. chromic 25 vols., 2 per cent. acetic 50 vols., water 25 vols.) were shelled in water; the vitellus was in the same solution for 5 minutes, water 10 minutes, and 35 per cent. and 50 per cent. alcohol 5 minutes each, 70 per cent. 30 minutes, and 90 per cent. *ad libitum*; the results were good, taking picrocarminate of lithium very well, if left long enough in stain. They all took borax-carmine very well. Both of these stains did well after the eggs were immersed in chromic  $1/3$  per cent. for 10 minutes, then shelled in a large quantity of water, vitellus in chromic  $1/3$  for 4 minutes, and water and grades of alcohol as before.

For permanent preservation of whole eggs it was found satisfactory to use 1 per cent. osmic acid for 5 minutes, and Merkel's fluid for 4 hours; after shelling, water and grades of alcohol, 2 minutes each to 70 per cent. alcohol.

**Examination of Tentacular Nerves of *Helix pomatia*.**†—Dr. P. Samassa worked only with fully extended tentacles; these he placed in a 2 per cent. solution of bichromate of potash; for four days a tentacle was laid in a mixture of 4 parts of 2 per cent. bichromate of potash and one part 1 per cent. osmic acid, and then for not more than a day in  $3/4$  per cent. solution of silver nitrate; 6 or 8 hours will generally be found enough to sufficiently blacken the fibres. Special care was taken to cut the object as soon as possible after removal from the silver solution; it was not hardened in alcohol, but in chloroform, and sections of  $25\ \mu$  were obtained an hour after removal from silver. Although the author was unsuccessful with Golgi's methylen-blue method he does not despair of ultimate success.

**Making and Preserving Specimens of Bacteria for Museum Purposes.**‡—Dr. C. Krückmann highly commends the use of formalin for

\* Amer. Natural., xxviii. (1894) pp. 528-31.

† Zool. Jahrb. (Anat. Abth.), vii. (1894) pp. 584 and 5.

‡ Centralbl. f. Bakteriol. u. Parasitenk., xv. (1894) pp. 851-7.

preserving cultivations of bacteria for museum purposes. Formalin, which has a tanning action, is best employed in conjunction with sublimate. The process of conservation is best begun with a solution of moderate strength, and gradually increased to pure formalin, as the colours, if any, are thereby better retained, and the crumpling, which is more or less inevitable, much diminished. This reagent acts well with all media except potato, and the water used for diluting it should be previously boiled. Some of the author's preparations were fixed in the following manner. They were placed in an exsiccator containing formalin instead of sulphuric acid, in order to tan the surface of the medium. They were then covered with a 1 to 10 solution of formalin containing 0·1 per cent. of sublimate. This was afterwards changed for a somewhat stronger solution, and the test-tubes eventually hermetically sealed up.

**Preservation of Marine Animals in Formaldehyde.\***—Dr. Th. Pintner has obtained excellent results by using 1 per cent. solution of formaldehyde in the preservation of Medusæ, Sponges, and the like. The form and colour are very perfectly retained, and the organisms are usable for histological or anatomical purposes.

(3) Cutting, including Imbedding and Microtomes.

**Orienting Small Objects for Sectioning.†**—Mr. W. Patten's method for orienting large numbers of small objects is as follows:—Small strips of glazed writing-paper, marked with two sets of raised parallel lines running at right angles to each other, are cut, and at suitable intervals a very small drop of thick collodion and clove oil, about the consistence of honey, is added. The drops are arranged close together along one of the ribs that run lengthwise of the paper. The object to be imbedded is cleared in clove or bergamot oil, not turpentine. It is then raised on the point of a knife, and after the excess oil is drawn off, transferred to a drop of the thick collodion. It may then be adjusted at leisure and will stay in any desired position.

When half a dozen or more objects are oriented in reference to the cross lines (which are to be parallel to the section planes), the whole thing is to be placed in turpentine. This washes out the clove oil and fixes the objects very firmly to the paper. When submerged in turpentine, the relation of each object to the orienting lines can be determined under the Microscope with greater precision than before.

The paper with the attached objects is now placed in the paraffin bath and finally removed and covered with paraffin in the usual way. After cooling in water the block is trimmed and the softened paper peeled off, leaving the objects in the paraffin close to the under surface of the block. This surface is now marked by the orienting lines of the rubbed paper, and also by the record numbers which before imbedding were written with a soft pencil on the paper. The block is now fixed on the microtome, and the objects cut one after the other, as though a single object had been imbedded; or a number of them may be cut together, if they have been arranged with that object in view. For

\* Verh. Zool.-Bot. Ges. Wien, xlv. (1894) p. 8.

† Amer. Natural., xxviii. (1894) pp. 369-1.

example, we may use a thinner collodion and arrange a large number of insect embryos or small worms in a compact bundle like a package of cigarettes, and cut them all at once.

#### New Machine for Cutting Thin Sections of Rocks and Minerals.\*

—This machine was constructed for the petrographical laboratory of the John Hopkins University in Baltimore, by the Donaldson Macrae Electric Company. Its most interesting feature is that it is driven by an electro-motor.

#### (4) Staining and Injecting.

##### Modification of Golgi's Method for Study of Human Brain.†—

Dr. W. Lloyd Andriezen states that he obtains good results with the following method:—Slices of brain 2 to 4 mm. in diameter were suspended in 95 ccm. of 2 per cent. bichromate of potash; after 10 to 15 minutes 5 ccm. of 1 per cent. osmic acid was added, and the whole left in the dark for a day; the specimen was then suspended for 2 days in 90 ccm. of 2.5 per cent. bichromate and 10 ccm. of 1 per cent. osmic; and was finally changed into Golgi's mixture of 80 ccm. 3 per cent. bichromate and 20 ccm. of 1 per cent. osmic. It is well to have two specimens, hardened  $3\frac{1}{2}$  and  $4\frac{1}{2}$  days respectively. After this rinse in distilled water, plunge into  $\frac{3}{4}$  per cent. silver nitrate solution for 5 to 15 minutes in the dark, change into 100 ccm. of silver nitrate to which one drop of formic acid has been added; place in incubator in the dark at a temperature of  $25^{\circ}$  to  $27^{\circ}$ , change silver solution for fresh after a day; after three or four days rinse in methylated spirit and fix in wax, cut under spirit, pick out best sections, and place in a large quantity of distilled water till nearly freed from spirit (about 5 minutes); then place sections in  $\frac{3}{4}$  per cent. silver nitrate for  $\frac{1}{2}$  to 1 hour; dehydrate in spirit, and then in xylol-piridine, equal parts, clear twice in xylol, and mount in xylol-dammar, hastening drying by placing the slides in an incubator at  $37^{\circ}$  to  $40^{\circ}$  for a day or rather more.

Successful preparations will show the nerve-cells and their processes down to their finest ramifications and endings, and all the cell-elements will be sharply differentiated from one another and from the clear ground substance. The method is applicable to adult human brains (which Golgi's methods are not), provided post-mortem changes are not too advanced, or the tissue disintegrated or softened.

Two new Staining-reagents for Meristems.‡—In the place of the anilin-brown and ferric tannate hitherto employed, M. A. Lemaire recommends, for staining the walls of cells in process of division, the use of two staining reagents, known in Germany as "Schwarzbraun" and "Kernschwarz," the composition of which is not given. To the walls of cells deprived of their protoplasmic contents the former gives a brown colour which is not destroyed by absolute alcohol, xylol, or Canada balsam. The latter reagent stains the nucleus black, the rest of the protoplasm being nearly unaffected unless the solution is very strong. The sections must first be treated with hypochlorite and potassa, and the latter removed by water slightly acidulated by acetic acid.

\* Amer. Journ. Sci., iii. 45 (1893) p. 102. See Zeitschr. f. Instrumentenk., xiv. (1894) pp. 184-5.

† Brit. Med. Journ., No. 1739 (1894) p. 309.

‡ Bull. Soc. Bot. France, xli. (1894) pp. 88-90.

**Staining Reactions of Sputum.\***—Dr. A. Schmidt finds that the fluid or fundamental substance of sputum assumes different colours, according to its origin. While the cell elements always stain uniformly, the red corpuscles are orange-red, the protoplasm of other cell elements is red-violet, the nuclei are blue-green, the eosinophilous cells brick-red. The method for staining the fundamental substance is as follows:—Put a piece of sputum about the size of a pea in a test-tube. Half fill the tube with a  $2\frac{1}{2}$  per cent. alcoholic solution of sublimate, shake until the sputum is broken up into fine lumps; then allow to stand for 2 or 3 minutes. Decant off the fluid and wash the lumps with distilled water, after which stain with Ehrlich-Biondi solution for 5–6 minutes. Excess of colour is next removed by washing again in distilled water. The whole procedure does not last more than a quarter of an hour. By this procedure pneumonic sputum rich in albumen is stained red; mucous sputum a greenish blue; the greener the sputum, the greater the quantity of mucus. The serous sputum of pleurisy is of a red-violet. Purulent sputum, rich in leucocytes, is also red-violet. Sanious sputum is of an orange-red, owing to the presence of hæmoglobin.

**New Procedure for Staining Gonococcus.†**—Dr. Lanz dries the secretion on cover-glasses in the usual way. The covers are then placed for  $\frac{1}{2}$  to 2 minutes in 20 per cent. trichloroacetic acid. Having been washed in water, the film surface is treated for 5 minutes with methylen-blue solution (30 ccm. water, 1–2 drops of 5 per cent. KHO solution, saturated alcoholic solution of methylen-blue until the mixture assumes a dark-blue hue). They are again washed, then dried and mounted in balsam. By this procedure the gonococci stand out in bold relief from the cells, which have been rendered transparent by the trichloroacetic acid. The preparations may be contrast-stained with Bismarck-brown ( $\frac{1}{4}$ – $\frac{1}{2}$  minute) after the methylen-blue.

**Bleaching Animals and Sections fixed with Osmic Mixtures.‡**—Dr. D. Carazzi finds that the inconveniences of the chlorine or the peroxide-of-hydrogen mixtures are not to be found in his peroxide-of-sodium method. The compound has the formula  $\text{Na}_2\text{O}_2$ , and is a yellowish powder; when put into water it is alkaline, caustic soda being formed. If, however, the water be mixed with acid, the soda combines with the acid; mineral acids must not be used, but tartaric or acetic. Ten-per-cent. solution of acid is put in a vessel for animals and in a test-tube for microscopical sections; add a small quantity of peroxide and slowly add 70 per cent. alcohol to the surface of the water; put the objects into the alcohol; the oxygen escapes from the water, rises quickly, dissolves slowly in the alcohol and bleaches the specimen.

(5) Mounting, including Slides, Preservative Fluids, &c.

**Mounting Small Objects in Cells.§**—Mr. W. Patten mounts a large number of objects under one cover, in perfect order and in any desired

\* Berlin Klin. Wochenschr., 1893. See Bull. Soc. Belge de Microscopie, xx. (1893–4) pp. 182–3.

† Deutsch. Med. Wochenschr., 1894, No. 9. See Centralbl. f. Bakteriol. u. Parasitenk., xv. (1894) p. 776.

‡ Zool. Anzeig., xvii. (1894) p. 135.

§ Amer. Natur., xxviii. (1894) p. 362.



position, in the following manner:—A cell of the requisite dimensions is constructed and small drops, close together in rows, of thick collodion and clove oil, are placed therein. An egg of *Limulus* or head of insect embryo, &c., is taken out of the clove oil, drained and placed in a drop of collodion in any desired position. A great many eggs may thus be arranged like serial sections under one cover-glass. Before adding the balsam the slide is immersed in turpentine, which serves to wash away the clove oil, and leave the eggs firmly fixed in the collodion. The only precaution necessary is not to use too much collodion. It is surprising to find the small amount necessary, and the firmness with which the objects are held in place by it.

**Cleaning Dirty Slides and Cover-glasses.\***—Prof. Zettnow finds that the following fluid is very useful for cleaning slides or covers dirty with oil or balsam. Two litres of the fluid, which may be used five or six times, will clean 150–200 slides and about 300 cover-slips:—200 grm. of red chromate of potash are dissolved in 2 litres of hot water, and then 200 ccm. of strong sulphuric acid are gradually added, the mixture being stirred constantly the while.

It is necessary, of course, to previously remove the covers from the slides. This is easily done by heating them for two or three seconds over a Bunsen's burner, when the two can be easily separated. Slides when soaked in this fluid are easily cleaned, as the fluid softens the resin, and after an immersion in spirit they are brightened up with a cloth.

Cover-glasses should be placed in a porcelain vessel filled with the fluid and this heated in a water-bath for 10 minutes. The softened resin floats up as a greenish scum, and this can be easily removed from the surface. When all the covers seem clean they are to be washed with water, and afterwards immersed in a dilute caustic soda solution. This should be warmed again in a water-bath for about 5 minutes. The last two stages are repeated, after which the covers are placed in spirit for a while, and then dried with a clean cloth.

#### (6) Miscellaneous.

**Diagnosis of Cholera by the Microscope.†**—M. J. Denys states that it is almost always possible to make a diagnosis of cholera by means of a microscopical examination of the vomit or dejecta, the basis of the diagnosis being founded on the mobility of the organisms, which is much greater in these fluids than in cultivations. The presence of the bacilli during the acute stage is constant, while when the patient is recovering they are less frequent. This examination of the stools and vomit, put up naturally or mixed with a drop of bouillon, is superior to the permanent stained preparations. It is not intended to supersede any further examination by means of cultivations.

\* Centralbl. f. Bakteriol. u. Parasitenk., xv. (1894) pp. 555–6.

† Tom. cit., pp. 818–9.

## PROCEEDINGS OF THE SOCIETY.

MEETING OF 20TH JUNE, 1894, AT 20 HANOVER SQUARE, W.  
A. W. BENNETT, ESQ., M.A., IN THE CHAIR.

The Minutes of the Meeting of 16th May last were read and confirmed, and were signed by the Chairman.

The List of Donations (exclusive of exchanges and reprints) received since the last meeting was submitted, and the thanks of the Society were given to the donors.

	From
Catalogue of Scientific Papers. Vol. x. (4to, London, 1894) ..	<i>The Royal Society.</i>
De-Toni, J. B., Sylloge Algarum. Vol. ii. sect. 3. (8vo, Patavii, 1894) .. .. .	<i>The Author.</i>
Transactions of the Liverpool Biological Society. Vols. i.-vii. (8vo, Liverpool, 1887-93) .. .. .	<i>The Society.</i>
20th Annual Report of the New Hampshire College of Agriculture. (8vo, Concord, 1892) .. .. .	<i>Dr. C. M. Weed.</i>
Three Slides and two Photomicrographs of <i>Artemia fertilis</i> ..	<i>Dr. J. E. Talmage.</i>
Two Photomicrographs of Gonococci; a Stereoscopic Photomicrograph of Injected Muscle .. .. .	<i>Dr. W. C. Borden.</i>
Six Photomicrographs in frame .. .. .	<i>Mr. T. Charters White.</i>

Dr. J. E. Talmage, of Salt Lake City, Utah, said that it might perhaps be remembered that at the meeting of the Society in June 1891 he exhibited some specimens of the Brine Shrimp, *Artemia fertilis*, from the Great Salt Lake, and he then called attention to the great difficulty of making satisfactory preparations for exhibition under the Microscope. It was suggested that the best medium might possibly be the lake water, and he had found that for unstained preparations an excellent method of preserving was the use of a mixture composed of 75 per cent. of lake water, 10 per cent. of a solution of alum, 10 per cent. alcohol, and 5 per cent. of solution of corrosive sublimate. In this it was possible to mount the creature at once, as it spread itself out upon the slide in a manner which displayed all its parts extremely well. By examining the specimen exhibited under a Microscope in the room Fellows of the Society would see with what perfection this operation was performed by the shrimp itself. For staining purposes the living shrimp should be slowly transferred to brine of a less density than that of the lake until a proportion was reached of 1/4 brine and the rest fresh water; it would keep in this for some time, and could then be killed and stained with eosin, which answered very well. Attempts to stain with Bismarck brown were reported to result in absolute failure. The photographs exhibited in the room showed the shrimp with great minuteness, and gave a good idea of the way in which it spread itself out. He had also brought to the meeting some specimens of the Oolitic sand from the Great Salt Lake. Some of this was shown under one of the Microscopes on the table, and he had also with him a quantity of

samples of the same which he should be pleased to distribute amongst those present who were interested by it.

The thanks of the meeting were voted to Dr. Talmage for his communication.

Prof. F. Jeffrey Bell said that Mr. T. Charters White had intimated to the Council his intention to present to the Society the photomicrographs which formed his contribution to the exhibit of the Society at the recent Exhibition at Chicago.

Mr. T. Charters White was much obliged for the manner in which this gift had been received; it had been his desire from the first to ask their acceptance of these photographs as a memento of their contribution to the Chicago exhibits; they were platinotypes, and therefore ought to be permanent, and he thought also they were such as he need not be ashamed of, as the detail was in most cases so very clearly brought out.

The Chairman was sure the Society would join the Council in thanking Mr. White very heartily for presenting them with these illustrations of what the Microscope could do in the matter of photography.

A vote of thanks to Mr. T. Charters White was put and carried by acclamation.

Dr. W. H. Dallinger said that at the April meeting of the Society there were some stereoscopic photomicrographs exhibited by Dr. Borden, but it was remarked at the time that the stereoscopic effect was not so apparent as they could have wished. Dr. Borden had now sent another specimen, showing a portion of the muscle of a cat in which the stereoscopic projection was very obvious, as would be seen by those who examined it through the stereoscope which was passed round for the purpose. There were also two bacteriological photographs which were very interesting in their way.

Dr. Dallinger exhibited and described a novel form of mechanical stage for the Microscope, which had been produced by Messrs. Swift. It was not often, he said, that any one had the opportunity of calling attention to anything which was actually new in connection with the mechanical portion of the Microscope, but he believed that such an opportunity occurred to him that evening. He had the pleasure a short time ago of calling the attention of the Society to a new four-footed, or actually, three-footed Microscope, by Mr. Swift, and he believed the instrument to be a very good one for the purposes for which it was made, but he had always thought that a mechanical stage would be of great use if such an instrument could be fitted with it, but unfortunately the expense had been against the carrying out of this idea. Messrs. Swift had now, however, succeeded in their desire to comply with his request, and had produced a mechanical stage which fulfilled all the requirements of ordinary use, and could be made for a comparatively low price. All those hitherto made had consisted of plates moving over each other by means of rack-and-pinion movements; these require to be made with great accuracy, and must be fitted in the best possible manner, if expected to last. The principle of this new design was entirely different, and was also extremely simple, the longitudinal motion being

accomplished by means of some small wheels which traversed the outer edges of the horse-shoe plate, the transverse movement being given to the slide itself by means of the rotation of other wheels caused to clip it upon either edge by the pressure of a spring. Motion was imparted to the wheels by the rotation of a milled head to each set which acted upon an endless screw. By means of diagrams Dr. Dallinger was able very lucidly to explain the mechanical details of this extremely ingenious and novel design, which he further stated could be produced at about one-half the cost of the Mayall stage, which was perhaps the best reliable form previously introduced.

The Chairman said they were greatly indebted to Dr. Dallinger for the description of this new stage, which no doubt had been followed by all with great interest.

Mr. T. Comber said he had been examining the details of this very admirable contrivance before the meeting began, and it occurred to him, that excellent as it was, there was one improvement which could be made in it. He noticed that the milled heads which turned the wheels were placed one on one side of the stage and the other at the opposite side, so that both hands would be required to work it; this, he thought, would be rather inconvenient. If, however, both these were on the same side, they could be managed by one hand, leaving the other free to work the focusing arrangement; this appeared to him to be a practical improvement which he thought it would be possible to carry out.

Mr. J. Swift said that this improvement had already been suggested by Mr. Karop, and there would be no difficulty in carrying it out.

Dr. Dallinger said he desired rather to abate criticism upon a thing which he was so thankful to get, feeling that it would be a great pity to sacrifice the instrument for the sake of some ideal improvement, but he might perhaps mention that the idea of Mr. Nelson in having the horse-shoe stage was that the fingers might have free access to that part which the arm in front seemed to close against them.

Mr. J. More, jun., thought the success of the whole thing depended upon the accuracy of the edges of the slide; if these were parallel, of course it would work, but very often the slides were not so true, and this would prevent it from acting.

Dr. Dallinger thought the non-parallelism of the slide would affect the working very slightly by causing the movement across the field to be at a small angle of inclination, but the spring would be quite sufficient to keep the wheels in good contact with the slide even if its edges were considerably out of parallel.

Mr. C. Beck thought the idea was extremely ingenious, and that Mr. Swift was much to be complimented upon the successful way in which it had been carried out, because it was certainly new in design, and seemed far more likely to be useful than some other contrivances they had seen for the same purpose. He noticed that, to prevent any tendency for the slide to rise from its plane, the wheels were slightly bevelled down. The question as to whether the slide moved in straight lines or not, was one which made no difference for practical purposes.

---



Mr. J. J. Harvey described a method of mounting Foraminifera so that they could be moved in all directions whilst under examination. Specimens in illustration were exhibited.

Mr. T. Comber read a paper "On the Unreliability of certain Characters generally accepted for Specific Diagnosis in the Diatomaceæ."

The Chairman said that, when, through the kindness of their Secretary, the paper which they had just heard was placed in his hands for perusal, it seemed to him undoubtedly one which it was eminently desirable to publish as a corrective to the tendency to the excessive multiplication of species which was so vast and growing an evil in every branch of natural history. The question of polymorphism was one of great importance in this connection. In the highest classes of plants they had polymorphism in the leaves; in the early stages of some of the common Conifers for instance, the structure of the leaves was extremely different from the later growths; whilst in the Fungi and the Algæ questions continually arose as to whether organisms which appeared to be totally different from each other, were not after all the same things in different stages; and the lower they went down in the scale, the more they found themselves confronted with these problems. He had lately been reading a paper in the *Comptes Rendus* in which similar points had been raised as to the Diatomaceæ, based upon observations made by the author in Auvergne, in the course of which he mentioned that those found at a great depth in the lake varied from those of the same species near the surface in exhibiting a diminished number of striæ; and he remembered that specimens found at great heights in the Jura had also a diminished number of striæ. The subject was certainly one which was well worthy of further consideration. He could not refrain from referring to the very great loss they had sustained by the death of their late colleague Mr. C. Haughton Gill, who was carrying out investigations of this kind in a manner which gave great promise of valuable results. He only hoped that Mr. Comber and others might be able to continue the work which had been so prematurely closed.

Prof. Bell, speaking as a zoologist, had been greatly surprised to note that, although they had so often been informed that botanists had arrived at a pitch of perfection which zoologists were far from having reached, the two chief cases quoted as examples were drawn from the kingdom of zoology. There was, as was well known, a general tendency to regard variations as new species, but experience was showing them that the more complete their collections became the more need they showed for caution and reflection in this respect. With regard to birds the Americans had taken up the question, and recognizing the variations which occurred in different regions of their continent, had adopted the plan of indicating these by giving a third, sub-specific, name. Lord Walsingham had called attention to the variations in Lepidoptera from different districts, and the magnificent gift by Mr. Hume to the British Museum of 80,000 birds from India showed very clearly how one species of bird varied in different parts of the peninsula. They were all of them subject at times to the temptation to make new species, for when they received things from abroad which were quite unlike

anything they had in their cabinets they were very apt to want to describe them as new species, whereas if they continued to collect and only got a sufficient number of specimens they would see that the two ends were united by a large number of intermediate forms. He hoped that some zoologist would take up this subject on the lines indicated by Mr. Comber, and he would also express a hope that Mr. Comber would himself be able to follow up this general paper with another to show how a large number of so-called different species could be grouped under one head.

Mr. J. Badeock having followed with a few remarks, a hearty vote of thanks to Mr. Comber for his paper was unanimously passed.

Prof. Bell said they had received from Mr. F. Chapman a further paper—No. 6 of the series—“On the Foraminifera of the Gault of Folkestone.” This, like the previous parts, was excellently illustrated, and would be of much value when published in the Journal, but, as they knew, papers of this kind were not entrancingly interesting to hear read *in extenso*. He therefore gave a short resumé of its contents, and proposed that it be taken as read, and appear in the Journal in due course.

Upon the motion of the Chairman, who regarded this paper as of special interest and value, the thanks of the Society were unanimously voted to Mr. Chapman for his communication.

Prof. Bell announced that the Council had arranged for the Library to be closed from 15th August to 15th September. He thought that the Fellows would perhaps notice that the June number of the Journal appeared to be thinner than the average. This was due to the fact that it contained very much less than the usual quantity of details as to new instruments and apparatus—not from any want of the usual research on the part of the editor, but because at the present time there appeared to be a considerable lull in the production of these things, so that they had met with very little that was new and still less that was valuable. The condition of that section of the Journal might be taken therefore as reflecting the condition of the glass and brass world.

The proceedings were then adjourned to October 17th.

The following Instruments, Objects, &c., were exhibited:—

The Society:—Dr. Borden's Photomicrographs. Foraminifera of the Gault of Folkestone, illustrating Mr. Chapman's paper.

Mr. T. Charters White's Photomicrographs.

Mr. T. Comber:—Drawings illustrating his paper.

Dr. W. H. Dallinger:—New Mechanical Stage by Messrs. Swift.

Mr. J. J. Harvey:—Foraminifera illustrating his Method of Mounting.

Mr. C. F. Rousselet:—The Painted Rotifer—*Notops pygmæus*.

Dr. J. E. Talmage:—Slides and Photomicrographs of *Artemia fertilis*. Ooliths from the Great Salt Lake.

NOV 27 1894

JOURNAL  
OF THE  
ROYAL MICROSCOPICAL SOCIETY.

OCTOBER 1894.

SUMMARY OF CURRENT RESEARCHES

*Relating to ZOOLOGY AND BOTANY (principally Invertebrata and Cryptogamia), MICROSCOPY, &c., including Original Communications from Fellows and Others.\**

ZOOLOGY.

A. VERTEBRATA:—Embryology, Histology, and General.

a. Embryology.†

**Morphology of Placenta.**‡—Under the title of “*Spolia Nemoris*,” Prof. A. A. W. Hubrecht gives a general and preliminary account of his observations on the placenta of Mammals collected during a trip to the Indian Archipelago. Of the Insectivore *Tupaia javanica* he was able to make a large collection; *Galeopithecus*, *Nycticebus*, and *Tarsius*, with *Manis*, were all collected in great numbers. For some of these, as earlier for the European *Sorex*, he was able to establish without doubt that the number of fecundated eggs, and even of early blastocysts, is constantly found to be greater than the number of ripe foetus that form the normal contents of a litter.

After a general account of the placenta in each of these five genera the author proceeds to discuss the origin and morphological significance of the cell-layers which constitute the two-layered blastocyst of Mammals, and the origin, minute anatomy and morphological significance of the placenta. Divergencies are so marked that, it is concluded, a larger number of genera must be investigated and compared before the time arrives for new theoretical generalizations.

**Maturation of the Ovum in Mammals.**§—Prof. M. Holl has studied this in the mouse, and in less detail, in the guinea-pig, rabbit, cat, cow, and man. He begins with a description of the young primitive ova. They lie at first among and afterwards under the superficial epithelial

\* The Society are not intended to be denoted by the editorial “we,” and they do not hold themselves responsible for the views of the authors of the papers noted, nor for any claim to novelty or otherwise made by them. The object of this part of the Journal is to present a summary of the papers *as actually published*, and to describe and illustrate Instruments, Apparatus, &c., which are either new or have not been previously described in this country.

† This section includes not only papers relating to Embryology properly so called, but also those dealing with Evolution, Development and Reproduction, and allied subjects. ‡ Quart. Journ. Micr. Sci., xxxvi. (1894) pp. 77–125 (4 pls.).

§ SB. Akad. Wiss. Wien, cii. (1893) pp. 249–308 (3 pls.).

cells of the ovary. During their growth, which affects all parts of the cell, the chromatin elements become more distinctly arranged and exhibit a considerable increase in mass. After the primitive ovum has attained a certain size, the formation of the tunica adventitia and follicle begins. These are described, and Prof. Holl goes on to discuss the series of changes in nucleus, cell-substance, and follicle which constitute the process of maturation. The ovum increases in size; the nucleus and nucleolus likewise; at a certain limit the nucleolus begins to be emptied and is broken up; the network character of the chromatin is lost, the knots of the net disappear, chromatin balls, which form the loops of the directive figure, appear, seemingly from the Schroen's granules of the nucleolus. It is difficult to reach certainty in regard to the history of the network. The chief changes in the cell-substance are increase in size and deposition of deutoplasmatic elements. The changes in the tunica and follicle are also described.

**Segmentation in Medullary Folds and Embryonic Rim.**\*—Prof. W. A. Loey begins an interesting communication by sketching the progress of knowledge in regard to the segmentation of the neural tube. He then describes the stages which he has observed in *Squalus acanthias*, where he finds the primitive metamerism in very much earlier stages than as yet recorded for other animals. The division into epiblastic segments is very distinct long before the closure of the neural groove (between Balfour's stages C and D), and it extends not only the whole length of the embryo, but also some distance into the embryonic rim. It is clearly defined throughout the whole length before the mesoblast has, to any extent, become divided into somites. The fact that the primitive segments extend into the embryonic rim, and are subsequently drawn into the axial embryo, supports the doctrine of concrecence that the germ-ring represents, or originally represented the divided halves of the embryo, and that it is formed in part by their apposition.

**Succession and Genesis of Mammalian Teeth.**†—Mr. M. F. Woodward summarizes our present knowledge of this subject, on which, as readers of this Journal will be aware, many workers have lately been engaged. The most remarkable result is the conclusion to be drawn from the work of Leche, Kükenthal, Röse, and others, that there appear to be traces of four dentitions in Mammals, viz. :—

1st or pre-milk dentition, minute calcified teeth never functional, present in *Myrmecobius*.

2nd or milk dentition, generally functional, the permanent dentition of Marsupials and Cetacea.

3rd or replacing dentition, functional in most Mammals.

4th dentition (?), rudimentary in the seal (?), occasionally functional in Man (?).

**Milk Dentition of Rodents.**‡—Mr. M. F. Woodward records the occurrence of vestiges of an early set of incisor teeth in the common mouse. "The squirrel, the rabbit, and the mouse present us with all the stages in the suppression of the vestigial milk incisors; in the former

\* Anat. Anzeig., ix. (1894) pp. 393-415 (11 figs.).

† Science Progress, i. (1894) pp. 438-53.

‡ Anat. Anzeig., ix. (1894) pp. 619-31 (3 figs.).



their relation to their successors is more typical; in the rabbit where the tooth of the second dentition is more largely developed, the milk predecessor has partially lost its independent enamel organ; and lastly in the mouse, where the successional tooth is still more out of proportion, the enamel organ of the milk tooth has completely disappeared, the tooth itself being very variable and when present excessively minute."

In the rabbit, about whose dentition confusion still exists, the first milk incisors above and below never cut the gum, but are absorbed in utero; the second milk incisors (none below) are functional, but are shed at about the third week of extra-uterine life; the milk premolars  $\frac{3}{2}$  are functional, but are shed at about three weeks.

From his study of the molars, Mr. Woodward is led to suggest that "the functional molars of the Mammalia are to be assigned to the same set as the replacing teeth of the anterior part of the jaw, i. e. the second dentition, unless we believe in a pre-milk dentition, when we must term this set the third dentition."

**Homologies and Origin of Mammalian Hair.**\*—Prof. E. B. Poulton, taking as his text the structure of the bill and hairs of *Ornithorhynchus paradoxus*, offers some criticisms of earlier views and some general conclusions of his own. He is inclined to oppose Gegenbaur's and Kölliker's distinction between hairs on the one hand, and feathers and scales on the other, which is founded on the fact that the former are developed from the base of a solid epithelial downgrowth, and the latter from an epithelial upgrowth. In *Ornithorhynchus* an open tube replaces the solid downgrowth of the higher Mammalia, and Prof. Poulton thinks that this is a clear demonstration that the solid cylinder is the abbreviated representative of the open tube, and that the significance of Gegenbaur's distinction between feather and hair falls to the ground. Another important point in *Ornithorhynchus* is the great length of the papilla projecting through the bulb into the lower part of the hair, for this suggests a previous development like that of a scale or feather from the surface of the epidermic covering of a papillary core traversing the structure from base to apex. Further confirmation is afforded by the axial rod of soft protoplasmic cells forming the medulla of hair; for, it is suggested, a shortening papillary core, surrounded by cells of the rete mucosum superficially undergoing cornification, would tend to leave just such an indication of its former presence.

Some of the features to which Maurer points as characteristic of feathers are equally characteristic of the hairs of *Ornithorhynchus*; in obliquity of direction and in distinction between an upper and a lower surface, the large hairs of that Monotreme resemble feathers.

As the new large hair of *Ornithorhynchus* is far advanced in development before the old one is shed we have practically a periodical shedding of the stratum corneum (hair) preceded by the formation of a new stratum corneum (new hair) below. "The succession of hairs is, in fact, the one exception to the gradual wearing off of the superficial corneal cells in Mammals which is so important a difference between them and Reptiles."

\* Quart. Journ. Micr. Sci., xxxvi. (1894) pp. 143-99 (3 pls.).

Prof. Poulton is led to believe that both feathers and hairs were, so far as their essential structure is concerned, existent in the Reptilian ancestors of Birds and Mammals. He gives a representation of a scale which contains everything essential to the structure of both hair and feather; on his hypothesis the hair represents the axial, and its inner root-sheath the appendicular part of a feather, and this gives an intelligible morphological significance to the mysterious inner root-sheath, which, owing to the mode of its development, is buried deeply beneath the surface.

The author believes that the invaginated inner root-sheath has an important function in retaining the hair in its follicle, for it presses tightly between the hair and the outer sheath, and with its innermost cells imbricated downwards and interlocking with the cuticular cells of the hair which are imbricated upwards it gives to the hair a swollen base which prevents it from being drawn with ease through the narrow neck of the follicle.

It is claimed that the views expressed in this essay suggest a simple and probable morphological explanation of every structure in the hair or associated with it. While the dermal papilla, epidermic bulb, medulla, hair-shaft, and inner root-sheath all follow naturally from the invagination of the suggested proto-mammalian scale, the outer root-sheath is clearly the wall of the pit into which the invagination took place.

**Relations of Notochord and Hypophysis in Birds.\***—M. G. Saint-Remy finds that the notochord is for a certain time fused with the hypophysis cerebri in birds, and this union is secondary and caused by the growth of the hypophysial invagination. The destruction of the end of the notochord is effected by the transformation of its elements into embryonic connective cells, which become lost in the surrounding connective tissue.

**Formation of Somatopleure and Vessels in the Chick.†**—Herr O. Drasch has combined the study of sections at right angles to the blastoderm with the study of "delaminated" or flat preparations. After fixing, he peeled off the ectoderm, and even the mesoderm from the endoderm. He finds that the vascular islands occur only in the middle germinal layer, and are formed exclusively from its cells; that the somatopleure is altogether epigenetic in its formation; and that the origin of the endothelial vascular wall goes hand in hand with the formation of the somatopleure.

**Ectodermic Differentiation in Necturus.‡**—Miss J. B. Platt has studied the ontogenetic differentiation of the ectoderm in *Necturus*. The "mesoderm" in the head is differentiated by the yolk spherules which it contains into two sharply separable tissues—mesectoderm and mesendoderm."

The direct emigration of cells from the single-layered ectoderm leads to the formation of a two-layered ectoderm, and ectoderm cells wander into the cerebral ganglia and into the nerves of the lateral organs. A deepening on the floor of the neural plate touches the wall of the arch-

\* Comptes Rendus, cxviii. (1894) pp. 1283-5.

† Anat. Anzeig., ix. (1894) pp. 567-70 (1 fig.).

‡ Arch. f. Mikr. Anat., xliiii. (1894) pp. 911-66 (6 pls.).

enteron in front of the tip of the notochord; it lies between trigeminal and facial rudiments and represents the beginning and posterior boundary of the cerebral curvature, not the infundibulum.

While in *Acanthias* the premandibular and most anterior head-cavities alone arise among the emigrant cells which wander from the wall of the archenteron in front of the wings of axial mesendoderm, in *Necturus* the mandibular mesendoderm also arises from cells which leave the wall of the archenteron in front of the axial mesendoderm.

In the origin of the hyomandibular cleft, the mesendoderm is not broken through, as in the succeeding clefts; the mandibular mesendoderm grows down and bounds the hyomandibular cleft on which ectoderm and endoderm are from the first in contact. The primitive rudiment of the trigeminal is chiefly formed from cells of the ectoderm lying above the brain; from the manner in which the neural folds close in that region it is plain that some of the external ectodermic cells also take part in forming the rudiment of the trigeminal.

Miss Platt describes in detail the origin and history of three longitudinal ectodermic ridges, which become connected by intersegmental transverse ridges. Behind the hyomandibular cleft there is a regular alternation of neural and mesendodermic segments. Regular intersegmental enlargements of the gut suggest a long series of gill-clefts.

The permanent connection of ganglia with brain arises at first from a centrifugal outgrowth of brain fibres. From the same ectoderm as that which gives origin to the dorsolateral mesectoderm of the trigeminal rudiment, the supraorbital line and the ophthalmicus superficialis facialis arise. Therefore this branch of the facial cannot be brought into serial homology with any branch of the trigeminal. The cells from the neural ridge and from the dorsolateral and epibranchial thickenings of the ectoderm form not nerves only, but share in the formation of the mesectodermic "connective tissue" and ganglia.

**Degeneration of Frog Ova.\***—Sig. P. Mingazzini has studied the ovarian degeneration brought about by preventing female frogs from liberating their ova, in other words by removing the males. There is a rapid diminution in the size of the ovaries, and the size and number of the ova. Three stages of ova are described: (a) with incipient, (b) with well-advanced (c) with complete degeneration. The final appearance of the ovum is that of a darkly pigmented mass of cells with very areolar protoplasm and with peripheral and radial connective fibres. The vitellus is chemically transformed into black pigments. Two kinds of elements help in the destruction, the epithelial cells of the follicle and the leucocytes. Both migrate inwards, feed on the degenerating vitellus, grow large and multiply by fragmentation. Mingazzini compares his results with similar observations on the degeneration of ova.

**Structure of the Nucleus in the Ovarian Ovum of Triton.†**—Prof. G. Born gives a full account of his observations on the ovarian ova of *Triton taeniatus*. The nucleus of the primitive ovum exhibits the typical structure of a resting nucleus; as the primitive ovum becomes definitely an ovum, the nuclear framework becomes a coil; with further growth

\* Atti R. Accad. Lincei (Rend.), ccxci. (1894) pp. 459-67.

† Arch. f. Mikr. Anat., xliii. (1894) pp. 1-79 (4 pls.).

the chromatin threads separate still more, become finer, and then disappear more or less completely. This is succeeded by a stage in which the chromatin threads form a diffuse framework of strands. Finally this concentrates into a coil.

The fine distribution of the chromatin in the germinal vesicle during the growth of the ovum may be interpreted as an exaggeration of the normal nuclear activity. When the ovum ceases simply to grow, and exhibits specific functions of secretion, &c., the chromatin forms diffuse strands, perhaps securing the greatest possible surface for its operations.

The nucleoli are of import for individual life, not in connection with reproduction. Thus, during the intense differentiation of the large and complex ovum, the nucleoli increase greatly in size and number, and become apposed to the nuclear wall; but when mitosis begins they disappear *en masse*.

The first coil stage of the chromatin represents in these yolk-laden ova the first phase of mitosis—a palingenetic phenomenon. The diffuse threadwork is a cœnogenetic adaptation. During the whole period of differentiation the coil-stage more or less persists; after differentiation is over a thickening and concentration of the chromatin produces the secondary coil, which then enters into mitosis.

**Development of Teeth in Fishes.\***—Dr. C. Röse finds that in *Lepidosteus*, the development of the teeth corresponds to the placoid type; the epithelial tissue is the truly formative element; no independently active growth of the connective-tissue papilla was to be seen.

In young of *Salmo salar*, *S. fario*, *Thymallus vulgaris*, and *Coregonus Hartmanni*, the tooth-rudiments of the first series are all of the placoid type. But the first replacement teeth of *Salmo salar* are slightly different. A roundish epithelial knob, like a hair-rudiment, penetrates inwards, and only then surrounds the connective tissue papilla. This mode of development is intermediate between the placoid type and the occurrence of an epithelial dental ridge.

**Epiphysis of Teleostean Fishes and of *Amia*.†**—Mr. C. Hill finds that, in various fishes, there are two epiphysial outgrowths from the roof of the primary fish-brain; the anterior of these is considered to be homologous with the parietal eye of Lacertilia, while the posterior is homologous with the epiphysis of those reptiles. It is probable that, in their primitive position, the two vesicles were side by side. It is thought likely that a study of the epiphyses of the larvæ of *Petromyzon* with special reference to their connection with the brain will yield results of great importance in settling the question whether the epiphyses were paired ancestral sense-organs.

**Development of the Kidneys in *Amia calva*.‡**—Dr. H. F. E. Jungersen found in the youngest embryo that the pronephric ducts showed no hint of tubules. Posteriorly, they united and opened behind the still closed anus; anteriorly each exhibited two funnels opening into the abdominal cavity in the region of the pectoral fins.

In the second stage, one ciliated funnel on each side opened into a

\* Anat. Anzeig., ix. (1894) pp. 653-62 (8 figs.).

† Journ. Morphol., ix. (1894) pp. 237-66 (2 pls.).

‡ Zool. Anzeig., xvii. (1894) pp. 246-52 (5 figs.).



pronephric chamber which was closed off from the abdominal cavity and contained a large glomerulus. The other funnel opened into the abdominal cavity. Sixteen or seventeen segments further back, the mesonephric tubules began, a pair in each of the following 16-17 segments, each with the rudiment of a Malpighian body, and a short cellular strand representing the beginning of a peritoneal funnel.

The third stage showed the differentiation of the mesonephric tubules. There is a combination of Ganoid and Teleostean characteristics, the development of the mesonephros being more Ganoid-like, that of the pronephros more Teleostean-like.

**Development of Cerebellum in Teleostei.\***—Dr. A. Schaper has studied the morphological and histological development of the Teleostean cerebellum in salmon and trout. It has a *bilaterally symmetrical* origin from a folding between the second and third embryonic vesicle; the posterior limbs of these folds form the foundation of the cerebellum, the median portion does not grow so quickly, but by secondary infolding induces the formation of the characteristic *valvula cerebelli*; as a residue of the median groove, a narrow canal persists, running just beneath the surface of the cerebellum, and communicating anteriorly and posteriorly with the much reduced *cavum cerebelli*; but in most fishes there is in the cerebellum no "central canal" in the ordinary sense. As to the homology of the Teleostean cerebellum and that of higher Vertebrates there can be no doubt.

There is no real distinction, such as His indicates, between "Keimzellen" and epithelial cells. The "Keimzellen" of His are young or dividing ectodermic epithelial cells. At a certain stage, these begin to form indifferent cells, which migrate peripherally, and form both nerve- and glia-cells. The original epithelial cells form a transitory supporting framework; only the ependym cells next the cavity persist. A transitory superficial granular layer arises wherever the typical cerebellar substance passes into a simple epithelial layer (ependym cells) or where the original epithelial layer persists. The superficial granular layer arises from indifferent cells; its subsequent disappearance depends on a gradual migration centralwards of its component elements. As differentiation proceeds a certain number of indifferent cells are excluded from the metamorphosis, and remain as reserve-material. The whole of the neuroglia is ectodermic.

**Development of Fins of Teleostei.†**—Mr. R. G. Harrison finds that the mesodermic structures of the median fins are formed from mesenchyme cells derived from the sclerotome, and from muscle-buds which are outgrowths of either the dorsal or the ventral edge of the myotomes. These fins so far retain their primitive metamerism in that each muscle-bud may be traced directly into a certain muscle of each segment of the fin. The segmentation of the extreme anterior portion of the fins is secondary, although in the adult no difference can be seen between it and the rest.

The ventral fins in the early stages of development likewise show signs of metamerism; in these the buds soon disintegrate, and in the space occupied by them a single muscle-mass develops, the adductor

\* Anat. Anzeig., ix. (1894) pp. 489-501 (20 figs.).

† Johns Hopkins Univ. Circ., xiii. (1894) pp. 59-61.

or retractor profundus; the other three muscles of this fin are developed from cells which have arisen from the somatopleure, and perhaps, also, from the sclerotome. This condition seems to be intermediate between what obtains in Elasmobranchs and Amphibians. The pectoral fin is derived entirely from somatopleuric cells. The author defers till the completion of further inquiries the full discussion of the meaning of this diversity in the origin of the muscle.

**Yolk-nucleus in *Cymatogaster aggregatus*.**\*—Mr. J. W. Hubbard has made a study of the compact irregular mass of granules which goes by this name, and is found in the yolk of the egg of certain animals. He comes to the conclusion that it originates from the nucleus soon after the cell becomes fully differentiated as an egg. It constantly moves towards the endodermic pole, where it is situated at maturity, and during later stages; it is capable of growing to a considerable size, and has a definite chemical composition. It remains in the egg until the closing of the blastopore, when it breaks up and disappears in the yolks. It is found in the eggs of many animals, and has been described as part of the male cell.

**Development of the Selachian Head.**†—Prof. C. K. Hoffmann finds that the nine head-somites described twelve years ago by van Wijhe in *Scyllium* and *Pristiurus* are to be seen very clearly in *Acanthias*, where, however, there are ten, the first trunk-segment (of van Wijhe) here taking part in forming the head. The segmental cerebral nerves and the dorsal spinal nerves are segmental outgrowths of precisely similar nature. Hoffmann gives the following table:—

	Somite.	Ventral Branches.	Dorsal Branches.
1	M. rectus superior, inferior, internus and obliquus inferior.	Oculomotor.	Ophthalmicus profundus with van Wijhe's ciliary ganglion.
2	M. obliquus superior.	Trochlear (?)	Trigeminus with its ganglion.
3	M. rectus externus.	Abducens.	Facial (acustico-facialis) with its ganglion.
4	No muscles	0.	Rudimentary ganglion aborts.
5	"	0.	Glossopharyngeal with its ganglion.
6	Transitory embryonic muscle-fibres.	Not found.	Anterior part of vagus and vagus ganglion.
7	Most anterior part of the great longitudinal muscle.	Embryonic only, aborts very early.	Posterior part of vagus and vagus ganglion.
8	" "	Well developed in embryo, aborts.	Very rudimentary, transitory ganglion.
9	" "	Strong branch, persists, innervates head part of the great longitudinal muscle.	Rudimentary ganglion aborts.
10	" " And also the most anterior part of the sternohyoid.	As above.	Ganglion persists, but seems to fuse with the first spinal ganglion.

\* Proc. Amer. Phil. Soc., xxxiii. (1894) pp. 74-83 (3 pls.).

† Anat. Anzeig., ix. (1894) pp. 638-53 (5 figs.).

**Development of Amphioxus.\***—Herr J. Eismond agrees with those who doubt the primitive nature of *Amphioxus*. He begins by referring to what Kowalevsky and Hatschek have made certain, that before the medullary rudiment becomes a groove it is overgrown in epibolic fashion by a kind of ectodermic skin. This grows forwards from the lower lip of the blastopore and the adjacent posterior lateral regions of the ectoderm. Hatschek's account is, however, more accurate than Kowalevsky's. The overgrowth is quite distinct from the closure of the medullary groove, and if *Amphioxus* be primitive what of this overgrowth-process in higher Vertebrates? The author explains the difficulty of bringing the development of the lancelet into line with that of higher Vertebrata, and his solution is this:—

The dorsal invagination in *Amphioxus* must be regarded as homologous with that in Selachii and Amphibia, while the persistently growing marginal zone of the formative germinal area corresponds with the overgrowing margin of the blastoderm in Fishes and Amphibians, where the overgrowth spreads over the vegetative portion. In short the overgrowing in *Amphioxus* is to be derived from an epibolè such as occurs in these other forms. Eismond supposes that the ovum of *Amphioxus* is secondarily poor in yolk, like that of placental mammals, and that the overgrowing in *Amphioxus* is homologous with the spreading of the blastoderm in Fishes and Amphibians, with this difference that the absence of yolk-ballast causes the growth to take place dorsally.

#### β. Histology.

**The Cell and the Animal Tissues.†**—Dr. R. S. Bergh published (in Danish) a book on the Cell and the Animal Tissues at the same time as Prof. Hertwig published his similar work. There is now a German edition of Bergh's book. It differs from Hertwig's analogous work in the subordination of physiological considerations, in taking less account of what is still very hypothetical, and in classifying tissues on a basis of comparative histology rather than on embryological considerations. All forms of tissues are linked by intermediate types, all are traceable to epithelium, but a classification according to the germinal layers from which they arise is not accepted.

**Number of Chromosomes in Animal-cells.‡**—Dr. O. vom Rath describes a sufficient number of cases to show that one cannot always expect to find in the nuclear spindle the number of chromosomes characteristic of the species. Though the result reached by Flemming and Rabl, which many others have corroborated, that there is for each species a typically constant number of chromosomes, remains generally true, vom Rath notes the occurrence of double, quadruple, and multiple chromosomes, and observes also that a chromosome may divide up into units of a lower order. In determining the number of chromosomes typical of the species, the mitoses of epithelial and endothelial cells are most important; modifications are most likely to occur in the sex-cells, cleavage-cells, embryonic cells, and blood-cells. Of some of these modifications descriptions and analyses are given.

\* Biol. Centralbl., xiv. (1894) pp. 353-60 (1 fig.).

† 'Vorlesungen über die Zelle und die einfachen Gewebe des tierischen Körpers. Mit einem Anhang, technische Anleitung zu einfachen histologischen Untersuchungen.' Wiesbaden, 1894, 8vo, 262 pp. and 138 figs. See Biol. Centralbl., xiv. (1894) pp. 478-80.

‡ Biol. Centralbl., xiv. (1894) pp. 449-71 (19 figs.).

**Generative and Embryonic Mitoses.\***—Dr. V. Haecker continues his studies on the behaviour and numerical relations of the chromosomes in mitosis. He believes that the chromatin substance of the nucleus has the tendency before each division to become by segmentation a characteristic number of idants constant for the species. In large nuclei rich in chromatin, such as occur during cleavage and development, the last segmentation of the threads tends to be omitted, so that bivalent elements are present. This suppression or imperfection of the last chromatin-segmentation is a wide-spread phenomenon in the life-cycle of generative cells (plurivalent divisions). In this way the quadruple groups in maturation-divisions are to be regarded as longitudinally cleft double elements. He gives a table from which the following is condensed:—

	Non-generative Mitoses.	Generative Mitoses.
Small to medium-sized nuclei, with small chromatin elements.	Somatic mitoses, with the normal number of elements. Embryonic mitoses, with the normal number of elements.	Mitoses in the germinal zone of <i>Ascaris</i> , in which the chromatin loops break up.
Medium-sized to large nuclei, with large chromatin elements	Embryonic mitoses, with half the normal number of elements (cf. vom Rath.	First division of maturation. (The chromatin threads occur in normal number, but closely associated in pairs.) Primitive genital cells of <i>Cyclops</i> . (The chromatin elements at first in pairs, but separate in the dyaster.) Heterotypical and homöotypical divisions in testes of salamander. (The union in pairs persists even in the dyaster?) Generative divisions in <i>Ascaris</i> . (More than two elements of a lower order remain united?)

Plurivalent mitoses.

**Histology and Histogenesis of Striped Muscle.†**—Dr. J. Schaffer begins with a discussion of Cohnheim's areas, passes to the structural and optical differences in fully grown muscles, contrasts this with adolescent and embryonic muscle, and ends with a discussion of sarcolysis.

The areas seen on a cross section of striped muscle fibres express a structural character of the living fibres, due to the disposition of the fibrillar and connective substance. The fibrils may be uniformly disposed in uniform sarcoplasm, or several fibrils may be united in pillars

\* Arch. f. Mikr. Anat., xliii. (1894) pp. 759-87 (1 pl., 2 figs.).

† SB. K. Akad. Wiss. Wien, cii. Abth. iii. (1893) pp. 1-148 (6 pls.).



with uniform sarcoplasm holding each set of fibrils together and often with granules around each area. With Knoll, the first type of fibre may be distinguished as poor in protoplasm (clear), the second as rich in protoplasm (dull), but there are transitions between them. The effects of various methods of technique on the appearance of the areas are described. Other differences are due to the state of contraction, alterations in metabolism, &c.

The fibrils of early embryonic stages do not correspond to the fibrils of the fully formed muscle, but rather to muscle-pillars. Muscle-fibres arise by the thickening and longitudinal cleavage of fibrillar tubes. The cleavage is always preceded by multiplication of nuclei. Repeated cleavage brings the nuclei out of the contractile substance of the embryonic fibre to the surface. Here and there even in newly born animals the embryonic mode of forming muscle-elements persists. Even in well-advanced embryos no strict limit can be drawn between fascia and muscle. Striped muscle is one of those tissues in which disruption and new formation of elements go hand in hand; the disruption is introduced by a process analogous to contraction; of this the naked, non-nucleated sarcolytes are structural expressions; nucleated sarcolytes also occur. New formation is due to the freed, axial, nucleated protoplasmic strands or to individual elements of these, the myoblasts of some authors. All these conclusions are discussed at length.

#### γ. General.

Is there a Cell-life without Micro-organisms.\*—Prof. W. Kochs has inquired into the dependence of cellular life on a symbiosis with bacteria. Thus he tried to find whether there were any living plants which did not contain micro-organisms. His method was to sterilize the husks of seeds and then let them germinate with proper precautions to evade bacteria. Often the experiment failed, but he succeeded in rearing plants (though not to maturity) without any bacteria being detected in or about them. The appearance of the dead, but not of course putrefying plants, was interesting. By experiments with fruits with uninjured skins and dipped in sublimate solution, he showed that bacteria are normally absent in the interior. Though results conflict not a little, it seems certain that it is often possible to find a drop of blood free from bacteria and to keep it from putrefaction. It is also known that the eggs of some animals, e. g. Entomostraca, will develop after sterilization. From these and other facts Kochs answers his question in the affirmative.

Haacke's Theory of Gemmaria.†—Dr. W. Haacke responds in a lively manner to R. von Lendenfeld's criticism of his two recent works. The critic insinuated that in Haacke's exposition the favourable facts were given undue prominence and the antagonistic facts subordinated; the author denies the impeachment. The critic said that Haacke undervalued the mixture of nuclei just because Weismann emphasized it; the author protests against such criticism. Similarly, in regard to many more serious points, the author vindicates himself. At the same time, he gives further explanations in regard to some of his conclusions.

\* Biol. Centralbl., xiv. (1894) pp. 481-91 (1 fig.). † Tom. cit., pp. 497-513.

**Disruption Products of Nuclein Acid.\***—Herren A. Kossel and A. Neumann begin by explaining why it is that we know so little in regard to such substances as nuclein acid. But that is the chemist's affair. Ours is that nuclein acid occurs, by itself or in association with albumen, in the nuclei of all living cells. Subjected to boiling water or boiling dilute mineral acids it gives rise to the so-called nuclein bases—adenin, hypoxanthin, guanin, xanthin. The authors have concentrated their attention on that particular form of nuclein acid which yields only adenin. From this they derive first "paranuclein acid," then "thymin acid," and finally a crystallizable substance "thymin" whose composition corresponds to the formula  $C_{23}H_{26}N_8O_6$ . This was got from the thymus gland and also from the spleen. From this thymin they then derived levulin acid, a carbohydrate. This discovery brings the chemist a step nearer knowing the constitution of nuclein acids. It also adds another to the possible sources of carbohydrates in the body.

**Distribution of Lacustrine Plankton.†**—Dr. O. Zacharias has convinced himself as to the erroneousness of the frequently accepted conclusion that there is uniformity of distribution in the plankton of a lake-basin. He gives facts showing that swarms may be local and that certain forms have their favourite haunts. A few sample hauls are apt to lead to partial conclusions; vertical hauls must be corrected by horizontal hauls; and quantitative plankton studies must be associated with qualitative investigation.

## B. INVERTEBRATA.

**False Mimicry.‡**—Prof. F. Plateau points out that true mimicry must be between animals living in the same district, under similar conditions, and occurring together at the same time of year, and that the mimicked form must possess means of defence which the mimicking form lacks. But there are cases of resemblance between different animals, in which the above conditions of true mimicry are not fulfilled. These are cases of "false mimicry," fortuitous resemblances due to the fact that the possible combinations of colours and shapes are not unlimited, and are therefore likely to repeat themselves.

He instances the Medusoid-like Amphipod (*Mimonectes*) described by Bovallius, the spider *Formicina lanestrina* which is ant-like, but is not found near ants, the two nocturnal Lepidoptera *Dichonia aprilina* L. and *Moma Orion* Esp., which are like one another, but appear at different seasons, the Argentine *Phyciodes* and the Old World *Vanessa*, the African *Cochlophora valvata* whose larval state is like the Gastropod *Valvata* along with which it does not occur.

**Terrestrial Fauna of Damma Island, East Indian Archipelago.§**—Mr. J. J. Walker, R.N., who visited this island during the voyage of H.M.S. 'Penguin,' writes a general introduction to a series of reports by a number of specialists. More than 180 species of terrestrial and freshwater forms were collected in five days, and were of considerable

\* SB. K. Preuss. Akad. Wiss., 1894, pp. 321-7.

† Biol. Centralbl., xiv. (1894) pp. 122-8; Forschungsberichte Biol. Stat. Plön, ii. (1894).

‡ Biol. Centralbl., xiv. (1894) pp. 471-3.

§ Ann. and Mag. Nat. Hist., xiv. (1894) pp. 49-71, 98-110.

interest, as the only previous zoological visitor to the island was a Dutch collector of birds. Nearly all the butterflies were found to be allied to or identical with those collected by Mr. H. O. Forbes in Timor-Laut, but among them was the wandering *Anosia plexippus*, found many thousands of miles from its original American home. The land and freshwater shells seem to be more similar to those of Timor-Laut than of Timor, between which Damma lies.

### Mollusca.

#### a. Cephalopoda.

Shells of *Sepia*, *Spirula*, and *Nautilus*.\* — Dr. A. Appellöf, after describing in detail the shells of these Cephalopods, institutes a comparison between them. In all three the chief divisions can be distinguished; an outer shell-wall and an inner chambered part; the former is structurally composed of distinct portions between which there are boundary lines which are always distinct and often sharply marked. The inner chambered part consists in all three of spaces bounded by the shell-wall and by septa. The septa are composed of layers, and these layers are direct continuations of those of the shell-wall.

In *Spirula* and *Nautilus* the siphon is well developed, but rudimentary in *Sepia*; in the two former it consists of two divisions, a tubular continuation of the septum, and of the same structure as it, and of another continuation which has a softer structure. In *Sepia* it is chiefly the upper or dorsal parts of the septa and of the siphon that are developed, and this is in relation with the flattened form of the shell; the homologues with the other two shells seem, however, to be clear. The cavity which is regarded as the rudimentary siphon-cavity seems to owe its form to the fact that if the shell became more and more flattened, and at the same time increased in breadth, it must, unless it is to occupy too much room, be diminished in height; this is effected by the lower parts of the septa and siphon being more and more compressed, until, as in *Sepia*, they are brought together in the hinder part of the shell; an intermediate stage is to be seen in the cocene *Belosepia*.

*Spirula* and *Nautilus* have a fleshy siphon which is a tubular prolongation of the mantle and is enclosed in the shell-siphon; a corresponding structure has been found in *Sepia*, where a pointed (though not hollow) projection of the hinder part of the mantle is continued into the rudimentary siphon-cavity. The chambers of *Spirula* and *Nautilus* agree in being, for the most part, hollow, and have shafts in a small part only; there are, however, shafts through the whole extent of the *Sepia*-shell; their presence is to be sought for in the feeble structure of the septa, for they serve as supports. The chambers are in all three forms secondary structures, for the cavities are at first filled with a soft chitinous mass, which splits later on, and becomes pressed against the walls of the chambers.

The shell-muscles are completely homologous in *Sepia* and *Nautilus*, but, in the present state of our knowledge, it is impossible to say how far this is true of *Spirula*. Although the three shells in their chief characters agree with one another, it is not to be denied that they exhibit

\* K. Svenska Vet. Akad. Hdlgr., xxv. No. 7 (1893) 106 pp. and 12 pls.

great differences, the first cause of which is the fact that that of *Nautilus* is external, and those of the other two internal. Growth must, in consequence, be different. The primary chambers of *Spirula* and *Nautilus* present considerable differences; that of the former, for example, has no proper septum, and the siphon commences far from the hinder wall of the chamber; in *Nautilus* there is a septum between the first and second chambers, and the end of the siphon is pressed against the hinder wall of the first.

The apparently great difference between *Sepia* and *Spirula* on the one hand and *Nautilus* on the other depends on the relation of the shell to the animal; the concave side of the *Sepia*-shell looks downwards, and if that of *Spirula* were unrolled it would have the same relation; in recent *Nautili* the relation is reversed, as the concave side looks upwards, but there are fossil Nautilidæ in which the relation is the same as in *Spirula* and *Sepia*.

**Cephalopoda of Amboina.\***—Dr. L. Joubin prefaces his account of the Cephalopods collected by MM. Bedot and Pictet with a list of the sixty-five species known from the Indo-Malayan area; indeed, Cephalopods appear to be very rich in and highly characteristic of that area. *Chiroteuthis Picteti* and *Loligo Picteti* are new, and are described in considerable detail.

**Copulation of Cephalopoda.†**—M. E. G. Racovitza describes the mode of copulation of *Sepiola Rondeletii*, which seems to be of the nature of a struggle between the male and female, as the latter cannot breathe during the act. The spermatophores are fixed on the folds of the large pouch which is found in the left half of the mantle-cavity; the spermatophore bursts on contact with sea-water; the ova are fertilized on their way to the exterior.

There are some notes, also, on the fertilization of *Rossia macrosoma*, and a description of the hectocotyized arms.

**Fecundation of Octopus vulgaris.‡**—M. E. G. Racovitza has observed that the male of *Octopus vulgaris* copulates with the female by introducing the extremity of its third right arm into the pallial cavity, from a distance. The female makes no great resistance to this, as the introduction of the hectocotylus has no effect on the normal respiration. Copulation lasts for an hour or more in consequence of the complicated acts which the arm of the male has to perform. The spermatophore, on being expelled from the orifice of the penis, passes into the funnel which places it in the groove of the hectocotylus. It is forced by the contractions of the walls of this imperfect canal towards the distal end of the arm, and so reaches the mantle-cavity of the female. The spoon-shaped end of the hectocotylus then places the extremity of the spermatophore against the edge of the orifice of the oviduct. The apparatus bursts on coming into contact with the sea-water which circulates in the cavity. The part which is evaginated is forced into the lumen of the canal of the oviduct. The freed spermatozoa are enabled to fertilize the eggs before the latter are covered by their shell.

\* Rev. Suisse Zool., ii. (1894) pp. 23-64 (4 pls.).

† Comptes Rendus, cxviii. (1894) pp. 722-4.

‡ Arch. Zool. Expér., iii. (1894) pp. 23-49.



Spawn and Embryos of *Eledone*.\* — Herr Korschelt gives a description of a mass of spawn of this Cephalopod, which was taken at Rovigno in August. There were about 140 eggs in the mass, which was attached to a *Pinna*-shell; each egg is surrounded by a transparent envelope, which is produced into a stalk; the eggs are of very large size compared with those of other Cephalopods, for without the stalk they measure 15 mm. This account does not agree with that of Joubin, but it is possible that the spawn of a different species of *Eledone* was examined by him. Herr Korschelt thinks his species was *E. moschata*. In more fully developed eggs, when the embryo was well advanced, the yolk-sac was found to be still of an extraordinarily large size. A more complete knowledge of the embryology of this Octopod would be of great interest.

#### B. Pteropoda.

Pteropods with Two Separate Sexual Orifices.† — Mr. H. McE. Knowler finds from a study of *Cavolinia longirostris* that the text-book statement that Pteropods have only one external generative orifice is incorrect. The author appears to accept the current statement for all other Pteropods, as, after describing the arrangements which obtain in *C. longirostris*, he proceeds to say that in the possession of two separate sexual openings it differs from all other Pteropods; these latter he regards as representing the more primitive condition of the hermaphroditic duct, while the species under discussion has become more specialized.

#### γ. Gastropoda.

Laws of Cleavage in *Limax*.‡ — Mr. C. A. Kofoid begins his essay with explaining his terminology. The egg is spoken of as having its animal pole uppermost, and the terms right and left, upper and lower, are used as if by one resident in the egg itself. By a "generation of cells" is meant all those cells which are removed from the ovum by the same number of cell-divisions, regardless of the time of appearance or position of such cells. The cells cleave in sets of four throughout the spiral period of cleavage, and these sets of four related cells of co-ordinate origin are called quartets. The regions of the segmenting egg occupied by the first four blastomeres and their derivatives during the spiral period are called quadrants, and designated by the letters *a, b, c, d*. In *Nereis* and *Umbrella*, these designate the left anterior, right anterior, right posterior, and left posterior quadrants respectively. By the term spiral is indicated "the divergence immediately after cleavage of the centre of the nucleus of the upper one of two daughter-cells from the vertical plane passing through the corresponding portion of the lower cell and the vertical axis of the egg." This divergence or apparent shifting of cells, in *Limax* at least, is the result of the obliquity of the plane of division, and is predetermined by the position of the spindle. It will be convenient to designate each cell of the spiral period of cleavage by three characters: (1) a letter, indicating the quadrant, e. g. *a*; (2) a first exponent indicating the generation, e. g.  $a^4$ ; (3) a second exponent indicating the quartet or story, e. g.  $a^{4 \cdot 1}$ . Mr. Kofoid's

\* SB. Ges. Nat. Freunde Berlin, 1893 (1894) pp. 68-73 (2 figs.).

† Johns Hopkins Univ. Circ., xiii. (1894) pp. 61 and 2.

‡ Proc. Am. Acad., 1894, pp. 180-203 (2 pls.).

chief result is that there exists an alternation in the direction of the spirals in successive generations. The spirals of the even generations are right spirals, those of the odd generations are left. The alternation is demonstrable in many forms of spiral cleavage, and it rests on the more fundamental and wide-spread tendency of the spindle to take a position at right angles to that of the spindle of the previous division. Mr. Kofoid also points out that one must consider not only the quantity of the yolk, but the quality of both yolk and protoplasm, in comparing different modes of cleavage.

**Primitive Nephridia of *Lymnæus*.**\*—Dr. R. v. Erlanger describes the paired excretory organs of larval freshwater Pulmonates. Each is a V-shaped canal, opening externally by an oval aperture near the anus, opening internally into the body-cavity. Each consists of several cells—not of one as Wolfsohn says—and the cell at the corner of the V is very large. The excurrent part, up to the large cell, is ectodermic, the inner part mesodermic. From the spoon-shaped internal funnel an undulating membrane runs down the afferent part of the nephridium. The internal aperture is lateral, not terminal.

**Peltella.**†—Dr. H. von Jhering gives an account of the structure of *Peltella palliolum*. He distinguishes the genus from *Parmacella*, with which it has been confused, and shows its great affinities with *Bulimulus*, of which, indeed, it almost appears to be a direct modification.

**Renal and Circulatory Organs of Chitons.**‡—Dr. L. Plate in some further § observations says that he has found confirmation of his view that B. Haller's description of the hinder tip of the ventricle opening into the connecting piece of the two auricles cannot be correct. In two species he found the median renal duct completely absent from the foot, and it is possible that it was not present in the species dissected by Haller and Sedgwick, neither of whom mention it.

**Oncidiella coquimbensis.**||—Dr. L. Plate gives an account of this new species from the coast of Chili, where it is not rare. The edge of the mantle is, contrary to rule, smooth; the coloration is extremely variable. The internal organization exhibits nothing specially noteworthy. This species is allied to Huppé's *Oncidium chilense* which is probably a true *Oncidiella*.

#### δ. Lamellibranchiata.

**Systematic Position of Trigonidæ.**¶—Dr. S. von Wöhrmann finds that the Trigonidæ and Najadæ ought not to form a special group of Schizodonts, but should be associated with the Heterodonts. The Najadæ are either marine (and extinct) or fresh-water forms, like *Unio*. Though there are certainly relations between the Unionidæ and *Trigonia*, they are not derived from it.

\* Biol. Centralbl., xiv. (1894) pp. 491-4 (2 figs.).

† Archiv Mus. Rio de Janeiro, viii. (1892) pp. 135-53 (2 pls.).

‡ SB. Akad. Wiss. Berlin, 1894, pp. 217 and 8.

§ See ante, p. 440.

|| SB. Akad. Wiss. Berlin, 1894, pp. 218 and 9.

¶ JB. K. K. Geolog. Reichsanstalt Wien, xliii. (1893) pp. 1-28 (3 pls.). See Zool. Centralbl., i. (1894) pp. 75 and 6.

## Molluscoida.

## a. Tunicata.

Vertebration of Tail of Appendiculariæ.\*—Mr. G. Lefevre has convinced himself that the interruption in the continuity of the muscle-fibres of the tail is artificial, and does not represent a true metamerism. With high magnification the ragged ends of the broken films may be seen, and in some cases the splits are not continuous, but are represented by zigzag rows of isolated clefts. Some specimens of *Oikopleura* collected in the Gulf Stream did not exhibit the slightest trace of breaks of any kind in the muscle-fibres; gentle stretching of the tails between forceps resulted, in some cases, in the production of eight transverse splits. There seems, therefore, to be little, if any, room for doubt that the vertebration of the tail of Appendicularians is an artefact, though the tendency of the muscle-fibres to break at definite intervals may be regarded as the first step towards vertebration; this is, of course, in opposition to Lankester's view that it is a remnant of a more marked vertebration in an ancestor of the present Appendiculariæ.

Variations in the Dorsal Tubercle of *Ascidia virginea*.† — Miss A. E. Warham has, at the suggestion of Prof. Herdman, extended his observations on the variations of this organ. She is able to recognize two simple forms, of both of which there are some eight variants.

## Arthropoda.

Walking of some Arthropoda.‡—Mr. H. H. Dixon has a preliminary note on the locomotion of various Insects, Spiders, and Scorpions. In his observations he used a quarter-plate camera with instantaneous shutter. In all the adults examined, except the Thysanura, the almost simultaneous motion of the "diagonals" is the rule, though instantaneous photography shows that it is not absolutely synchronous.

## a. Insecta.

Formation of Germinal Layers in Insects.§—Dr. R. Heymons has investigated the history of the germinal layers in *Phyllodromia* (*Blatta*) *germanica*, *Gryllotalpa vulgaris*, *Gryllus domesticus*, *G. campestris*, and *Forficula auricularia*. In all but the second of these the yolk-cells were found to disappear during the course of development, without taking any part in the formation of the embryo; the epithelium of the mid-gut, which only appears relatively late, does not arise from the lower cell-layers, but from the blind cords of the ectodermal stomodæum and proctodæum. From these two points cell-layers grow out to the middle of the body. The layer which corresponds to the endomesoderm of other authors appears to give rise to the fat body, the muscular system, blood-cells, &c., tissues which are ordinarily regarded as of mesodermal origin, and the author, therefore, calls it the mesoderm. The formation of the mesoderm has nothing to do with the invagination-process in a gastrula. It is a remarkable fact that the primitive groove may in

\* Johns Hopkins Univ. Circ., xiii. (1894) pp. 57 and 8 (3 figs.).

† Trans. Liverpool Biol. Soc., vii. (1894) pp. 98 and 9.

‡ Sci. Proc. Roy. Dublin Soc., vii. (1892) pp. 574-8.

§ SB. Akad. Wiss. Berlin, 1894, pp. 23-7.

some cases be completely wanting, and this is especially so in *Phyllo-dromia*, a form which for many reasons is supposed to be very primitive.

In those cases in which the mesoderm arises by a typical invagination, the author does not regard the invagination as a gastrulation, but as a simple mechanical process, caused by an aggregation of cells at one point. Analogous processes may be cited, and insect embryology alone offers sufficient examples; organs may in some Insects be formed by invagination that are in others developed by wandering or immigration; this idea offers an explanation of the as yet uncomprehended process of "lateral gastrulation."

It is possible that we must look for the endoderm in the cells that disappear in the yolk; if this be so the layer that forms the midgut of Insects is a neomorph, and if it be so we have the unpleasant result that Insects, in their adult stage, have no endoderm at all. Another explanation may be found in the supposition that, owing to certain causes, the endoderm does not become differentiated till very late; but such a hypothesis as this has very little, if anything, to support it.

The author promises a more detailed account of his studies.

**Alternation of Generations in Insects.\***—Herr E. Anderegg discusses the question of alternation of generations at great length. He begins with the fundamental constitution of matter, takes in a classification of the animal kingdom by the way, contrasts the inorganic and the organic, the plant and the animal, and does not neglect to raise several vexed questions in passing, e. g. in regard to "individuality." Reaching the facts he states the case for Cynipidæ, Phytophthira, Chermetidæ, and Aphidæ. That the parthenogenetic forms are part of the developmental cycle, the author allows, but they are not, as Lichtenstein would have it, merely developmental stages, bearing to the sexual forms the same kind of relation that larvæ bear to imagines. He agrees with Leuckart that the interpolated parthenogenetic individuals form equivalent generations, but will not accept the statement that they represent a heteromorphism of the species, as in seasonal dimorphism. The general conclusion seems to be that there is true alternation of generations in oak-Cynipidæ and Phytophthira. It seems to us that the chief value of the memoir is to be found in the author's concrete observations, in his summaries, and in the diagrammatic expressions of the complex life-histories, but not in the generalizations.

**Metamorphoses of Insects.†**—M. le Capitaine Xamben continues his account of the habits and metamorphoses of insects, dealing with larvæ of Paussidæ, Pselaphidæ, Silphidæ, Tregositidæ, Lamellicornes, and Buprestidæ.

**Relations between Colouring and Habit in Lepidoptera.‡**—Dr. M. Standfuss discusses the relations between the colouring of Palæarctic Macro-Lepidoptera and their habits. He begins by contrasting Rhopalocera and Heterocera in which the difference in the position of the wings when at rest is well known to be associated with a difference in

\* MT. Nat. Ges. Bern, 1893, pp. 1-69.

† Ann. Soc. Linn. Lyon, xxxix. (1892) pp. 135-94.

‡ Vierteljahrscr. Nat. Ges. Zürich, xxxix. (1894) pp. 85-119 (8 figs.).



the disposition of the colouring. He also points out relations between the nature of the colouring and the mode, time, and place of flight.

**Reproduction in Butterflies.\***—Dr. Ad. Seitz begins his third bionomical study by observing that the reproductive function is peculiarly dominant in the life of butterflies, but more so in the older forms, such as Cossidæ, Hepialidæ, and many Microlepidoptera, than in young genera such as *Apatura*, *Euripus*, and *Hestina*.

Psychidæ, Sesiidæ, and others tend to copulate immediately after becoming adults; the males (e. g. of *Heliconius charitonia*) may even await the emergence of the female; in many cases, however, some time is first spent in feeding. The females of *Psyche*-species spin their larval sac where the males are likely to see it; in many cases certain places appear to be rendezvous for the sexes; the odour of an imprisoned female often attracts a crowd of males. The search for the female is often very impetuous, and sometimes mistaken (or abnormal), thus the persistent pursuit of an Erycinid (*Emesis fatime* Cr.) by a *Colænis julia* is described. In mating, one must distinguish the suit and the choice; the former as well as the latter is sometimes on the female's part. Darwin's hypothetical interpretation of the use of the blue "eyes" of the female *Diadema bolina* is confirmed from direct observation. Bigamy and biandry are not infrequent. Repeated copulation on the part of a male has been observed in *Agria tau*, *Eudromis versicolora*, *Platypteryx hamula*, and *Selenoscopus nubeculosus*, all of which fly very early, when favourable weather is often rare, when therefore it may be advantageous that one male act as several. Various abnormal sexual relations are chronicled. Many cases of hybridization are known, perhaps as the result of likeness of odours, or from a strange female coming in between an impetuous couple on the crowded thistle-top. Notice is taken of the fertile result of certain crossings. In *Lasiocampa pini* the eventually disastrous effects of breeding in and in are illustrated. Seitz goes on to discuss egg-laying, the number and form of the eggs, &c. He doubts the accuracy of the observation that the nutrition of caterpillars alters the normal proportions of the sexes. Cases of birth after death are noted. About a score of Lepidoptera are now known to illustrate parthenogenesis, and a much larger number show casual hermaphroditism, which is the result of a physiological inhibition conserving the potentially bisexual embryonic state. Gynandromorphism is a more superficial phenomenon.

**Transformations of Saturniidæ.†**—Prof. A. S. Packard has an important paper on the life-histories of these Moths, of which the most valuable part, philosophically, is the attempt to discriminate, of the more salient ontogenetic features those that are congenital from those that are later and adaptational. It is probable that the group is derived from the Ceratocampidæ.

**Red Pigment of *Pyrrhocoris apterus*.‡**—M. C. Phisalix, after drying two litres of this hemipterous insect, isolated and dissolved a yellowish colouring matter; this was found by spectral analysis to be near

\* Zool. Jahrb. (Abth. Systematik. Biol.), vii. (1894) pp. 823-51.

† Proc. Amer. Acad. Sci., xx. (1893 [received July 1894]) pp. 55-92 (3 pls. and 11 figs.).

‡ Comptes Rendus, cxviii. (1894) pp. 1282 and 3.

carotine, and by injection into small mammals to have no physiological action.

Origin of the "Nasutus" (Soldier) of *Eutermes*.\*—Mr. H. McE. Knower has had the opportunity of examining the snouted form of a Jamaican species of *Eutermes*; in this species there are two kinds of wingless individuals—workers and soldiers; the latter have a much smaller abdomen than the former, and are, consequently, able to move much more actively; in their head there is a large vesicle with walls formed of a single layer of high, columnar, glandular cells; comparison with various workers showed that the "nasutus" is, like the more ordinary forms of soldiers, merely a more specialized worker. These "nasuti" are undoubtedly soldiers, though they lack the powerful jaws found in soldiers of other species; they perform all the functions of soldiers, when advancing with a column, and so on. The author has not been able to determine whether the secretion of the glandular vesicle is poisonous to enemies, but there is reason for supposing that it has proved a better weapon of defence than jaws, and has been continually improved, while the jaws have decreased in size and importance.

Alimentary Canal of Orthoptera.†—Dr. F. Werner has compared the relative length of the intestine in vegetarian and insectivorous Orthoptera. The result was unexpected. The plant-eating Acridiidae have a short, almost straight gut, rarely longer than the body; while the Locustidae have a longer gut, usually spirally coiled, especially in *Barbitistes* and *Phaneroptera*. Werner believes that the length and coiling of the intestine have nothing to do with the diet, but are correlated with the shape of the body and with the habits of life.

Oviposition in Acridiidae.‡—M. J. Künckel d'Herculis describes the means by which these Orthoptera bury their abdomen in the ground; there is no perforation of the ground, the hinder part of the body is merely forced into it; as the Arabs say, the females "plantent." On dissecting females whose abdomen had reached the maximum of distension, the author was surprised to find that the abdomen was filled with air; on the air being withdrawn the abdomen was reduced from 8 to 5 cm. in length. When the position is firmly taken up the females of the migratory Locust maintain the parts of their genital armature as widely separated as possible, and secrete a viscous material, which agglutinates the grains of sand, or the particles of earth at the bottom of the cavity, and they then begin to lay their eggs. These and the viscous material are emitted simultaneously, but the latter is peripheral, and so consolidates the walls of the cavity, which has the curved form of the abdomen. When the eggs are laid the viscous material continues to be shed, and, on drying, forms a stopper which protects the cavity.

Diptera Parasitic on Acridiidae.§—M. J. Künckel d'Herculis finds that the oviparous Muscidae with oophagous larva, that destroy the eggs deposited in the ground by Acridiidae, belong to the Anthomyiinae and the Muscinae. The latter, owing to the rapidity of their successive generations, destroy great quantities of the eggs of the migratory Locust.

\* Johns Hopkins Univ. Circ., xiii. (1894) pp. 58-9 (3 figs.).

† Biol. Centralbl., xiv. (1894) pp. 116-9.

‡ Comptes Rendus, cxix. (1894) pp. 244-7.

§ Op. cit., cxviii. (1894) pp. 1359-61.

The flies follow the flights of the Locust, and when they settle on the ground to copulate and lay their eggs, they surround them, and bore their way to their eggs. The Dipterous genus *Idia* is capable of boring its way into firm ground, but it is powerless in light and sandy soils. This explains why *Aceridium peregrinum* chooses soils of the latter kind.

#### γ. Protracheata.

*Peripatus*.\*—Mr. R. I. Pocock, in an account of the species of *Peripatus* of the West Indies, proposes to give generic names to the three groups hitherto included under the common name *Peripatus*. He considers that these groups are of considerably greater value than the genera of other orders of animals.

*Peripatus*, with the type *P. juliformis* of Guilding, has the legs furnished with four spinous pads, and the generative aperture of the adult is always situated between the legs of the penultimate pair; the species are found in the Neotropical region and possibly in Sumatra.

In all other species the legs have only three spinous pads, and the generative aperture is behind the penultimate pair of legs. When the latter is between the legs of the last pair and well in advance of the anus, the species are placed under *Peripatoides*; they are found in Australia and New Zealand. In the South African forms, which are called *Peripatopsis*, the genital aperture is behind the last pair of fully developed legs, and close to the anus at the hinder end of the body.

#### δ. Arachnida.

Vestigial Stigmata in Arachnida.†—Mr. H. M. Bernard points out that, if a collection of Thelyphonidæ be carefully looked through, it is impossible to avoid the conclusion that these Arachnids once possessed limbs with stigmata along at least seven abdominal segments, as definite scar-like markings, or even sharply circumscribed areas may be seen. It seems, from a comparison with *Scorpio*, reasonable to suppose that *Thelyphonus* originally possessed at least seven pairs of lung-books, five of which have now vanished.

The author is of opinion that the tails of these two genera are not primitive structures, but a later specialization; if, further, it is possible to homologize the anal glands of *Thelyphonus* with the poison-glands of *Scorpio*, and both of these with the original invaginations of the scar found on each side of the anal papillæ in the Chernetidæ, it will follow that all these tail-segments once possessed limbs with tracheal invaginations or their homologues.

Development of Pulmonary Sacs in Arachnids.‡—Dr. A. Jaworski finds from a study of the development of *Trochosa singoriensis* support for the conclusion first indicated by Schimkewitz that the so-called lungs of spiders are in the embryonic state manifoldly branched tracheæ. He traces the development, showing how the porch or *Vorraum* of the embryonic trachea becomes the so-called lung. The development

\* Journ. Linn. Soc. London, xxiv. (1894) pp. 518-26 and 542.

† Ann. and Mag. Nat. Hist., xiv. (1894) pp. 149-53 (3 figs.).

‡ Zeitschr. f. wiss. Zool., lviii. (1894) pp. 54-78 (1 pl.).

of the stigmata more or less along the whole body in Arachnida indicates the adherence of the Arachnids to the Tracheate series.

Jaworowski allows himself considerable range of speculation. Not only does he derive the respiratory organs of *Limulus* (supposed to be originally terrestrial) from the Arachnid type, that is from modified tracheæ, but he applies a similar theory to the Crustacea. The divisions of the limb are explained as modifications of a respiratory lamella; four reasons are urged against deriving the Crustacean limb from the Annelid parapodium, and five in favour of deriving the gills from the lamellæ of so-called lungs. In short the Crustacea passed through a Prototracheate stage. But as the author says, these "Ansichten sind vielleicht zu kühn."

**Eye of Phalangiidæ.\***—Herr F. Purcell finds two types, differing in the structure of the rhabdome—the *Leiobunum*-type and the *Acantholophus*-type, and describes these in detail. We can only cite a few outstanding results.

One of the most important characteristics of the retina is the constant arrangement of its elements in groups (retinulæ), each of four cells, and the union of the optic rods of these four cells into a rhabdome, which, though single, is composed of four rhabdomeres. There are no pigment or other cells between the retinulæ.

In all the species examined the rhabdome consists of two chemically different parts. The one part includes the whole central rhabdome and, in the *Acantholophus*-group, the distal portion of the peripheral rhabdomeres; the other part includes in the *Leiobunum* group the whole of the peripheral rhabdomeres, in the *Acantholophus* group only the proximal part of the same.

The eyes of Phalangiidæ are three-layered inverse eyes of ectodermic origin. The anterior median eyes of spiders, the eyes of Phalangiidæ, the median eyes of scorpions, and at any rate the median eyes of the king-crab form a series of homologous structures, characterized by an inverted retina with retinulæ or at least rhabdomeres. As a chief result of his investigation the author claims to have definitely proved that a retina composed of retinulæ or of a modification of these occurs in higher Arachnid orders—Phalangiidæ and Spiders.

**Irish Pycnogonida.†**—Mr. G. H. Carpenter has a short report on the Pycnogonids collected in deep water off the Irish coasts and on those in the Dublin Museum. The only list of Irish Pycnogonida is that of W. Thompson, who enumerated nine species; of these Mr. Carpenter can confirm only three or four; the remaining five in the list before us are now for the first time recorded as Irish. The widely distributed *Anoplodactylus petiolatus* is represented by a single female. The suggestion that *Phoxichilus* is descended from *Nymphon*-like ancestors is accepted, and further evidence brought to confirm it.

**Systematic Position of Trilobites.‡**—Mr. H. M. Bernard thinks that it is now possible to fix with great probability the zoological position of Trilobites. He considers that the bending round ventrally of the

\* Zeitschr. f. wiss. Zool., lviii. (1894) pp. 1-53 (2 pls.).

† Sci. Proc. Roy. Dublin Soc., viii. (1893) pp. 195-205 (1 pl.).

‡ Quart. Journ. Geol. Soc., l. (1894) pp. 411-32 (17 figs.).



first segment, the great labrum with antennæ attached at the sides, the "wandering" of the eyes, the pores which point to the probable presence of water-sacs, the head with a varying and progressively increasing number of segments, and the essentially lobate and phyllopodan type of limbs, serve, with other characters, to connect the Trilobites with *Apus*.

This relationship must not, however, be supposed to be direct; *Apus* lies in the direct line upwards from the original Annelidan ancestor to the modern Crustacea, while the Trilobites branched off from the line as forms specialized for creeping under the protection of a hard imbricated carapace. Two alternative lines of descent with modification are sketched, and it is urged that the repetition of the head-shield as pleuræ along the trunk-segments seems to be the specialization which characterizes the Trilobites.

Mr. Bernard thinks that these organisms, studied in the light of recent and especially American investigations, give important evidence as to the origin of the Crustacea. Stripped of their pleuræ and of the expansion of the head-shield the early Trilobites (e. g. *Olenellus*) are seen to be long, segmented animals tapering at the posterior end. The members of the group, as a whole, may be defined as fixed specialized stages in the evolution of the Crustacea from an Annelidan ancestor, which bent its mouth round ventrally so as to use its parapodia as jaws.

In the discussion which followed the reading of this paper Prof. G. B. Howes\* said some severe things of the "Limulus-an-Arachnid" theory.

#### e. Crustacea.

Crustacea of Malay Archipelago.†—Dr. L. Zehntner gives a list of the Malacostraca and Cirripedia collected by MM. Bedot and Pictet. It contains the names of ninety-four species, twenty-one of which are new; the large number is partly due to old Madreporæ and Tubiporæ having been broken open, when a very rich and interesting fauna of small forms was found. The new genus *Sphærocarcinus* is formed for *S. Bedoti* sp. n.; it is closely allied to *Lissocarcinus* and is founded on a single, female, specimen.

Histology of Nervous System of Embryonic Lobster.‡—Mr. E. J. Allen has studied the nervous system of late embryos of *Homarus vulgaris* by a modification of Ehrlich's methylen-blue method. The nerve-elements which stained may be divided into three groups.

(1) Elements of which both cell and fibre lie entirely in the ganglionic chain; these must be supposed to co-ordinate the action of its various parts.

(2) Elements which consist of a ganglion cell in the cord and a fibre which runs out at a lateral nerve-root; some, perhaps all, of these elements are connected with muscles, and are motor.

(3) Elements which consist of a cell lying outside the central ganglionic chain, and a fibre running from it to a ganglion; these must be regarded as sensory elements.

The co-ordinating elements are of four kinds:—(A) Elements made

\* Tom. cit., p. 433. † Rev. Suisse Zool., ii. (1894) pp. 135-214 (3 pls.).

‡ Proc. Roy. Soc. Lond., lv. (1894) pp. 407-14 (1 fig.).

up of a cell in the brain or one of the ganglia, and a fibre which runs posteriorly to the end of the cord, giving off collateral branches to the neuropile in each ganglion through which it passes; these may either decussate with the corresponding element of the other side, or pass down on the same side of the cord as that on which the cell lies. (B) Each element consists of a fibre starting from a cell in one of the thoracic ganglia, and running forward to the brain. (C) Each consists of a small cell in the anterior portion of the lateral mass of ganglion cells; the fibre, after taking a Z-shaped course through the neuropile, to which it gives off numerous arborescent branches, turns backwards, and, after running between a fibre of series D and the central mass of ganglion cells, ends in a tuft of fine branches at the posterior end of the ganglion next behind that in which the cell is situated. (D) These elements are, as already indicated, associated with series C, and both groups generally stain in the same preparation; their cells lie in the posterior portion of the lateral ganglionic mass; the fibre of each element passes forwards, giving off numerous arborescent branches to the neuropile; it enters the ganglion next in front, and ends in a terminal tuft which lies exactly opposite the terminal tuft of one of the C elements, and behind a lateral tuft which is formed by the D element of the next ganglion; the three tufts lie at exactly the same level in the cord, and are all in the focus of the Microscope at the same time.

**Development of *Gebia littoralis*.**\*—Mr. P. Butschinsky reports that the ova of *Gebia* have a large quantity of nutrient yolk; the first cleavage is in the interior of the yolk, and the eight cleavage-nuclei that are subsequently formed make their way to the surface of the egg. The nutrient yolk partly becomes united with the unsegmented central yolk-mass, and partly becomes completely separated from it. The final result is a blastula formed of a superficial layer of cells, and an internal vitelline mass. At this period some of the cells wander into the yolk, and form a small number of vitellyphages. These degenerate and soon disappear almost completely.

A blastodermic thickening appears on the ventral side of the egg, and in it three separate swellings can be distinguished; the germinal layers begin to be formed very early; the mesodermal layer, at its first appearance, has a paired structure, and consists of cells which are arranged in two longitudinal rows. The nervous system commences in the Nauplius-stage, and when the creature begins to lead a free life eighteen ganglionic swellings can be seen. The mesodermal cells do not form regular somites, but are scattered quite irregularly; they give rise to the heart and gonads as well as to the muscles. The dorsal surface of the heart remains open for a certain time, and the opening is covered by ectoderm. The gonads arise in the latest stages of embryonic life and are paired; some of the mesodermal cells increase rapidly in size and form the beginnings of the genital cells. The mid-gut is developed from two endodermal "Anlage" which are primitively separate; the hinder of these is closely related to the proctodæal invagination, and has the edges of its cup-shaped mass directed forwards. At the same time a similar collection of cells appears near the stomodæum, and has

\* Zool. Anzeig., xvii. (1894) pp. 253-6.

its free edges directed backwards; these edges grow towards one another, but not so fast that they meet by the time the embryo escapes, so that at that time the dorsal and ventral walls of the mid-gut still consist of scattered cells. At this period the hinder endodermal sack undergoes division in the longitudinal direction, and so gives rise to the first liver-sac.

Galatheidæ.\*—MM. A. Milne-Edwards and E. L. Bouvier discuss in detail the characters of the Galatheidæ, the ancestry and relations *inter se* of which are shown by the following diagram.

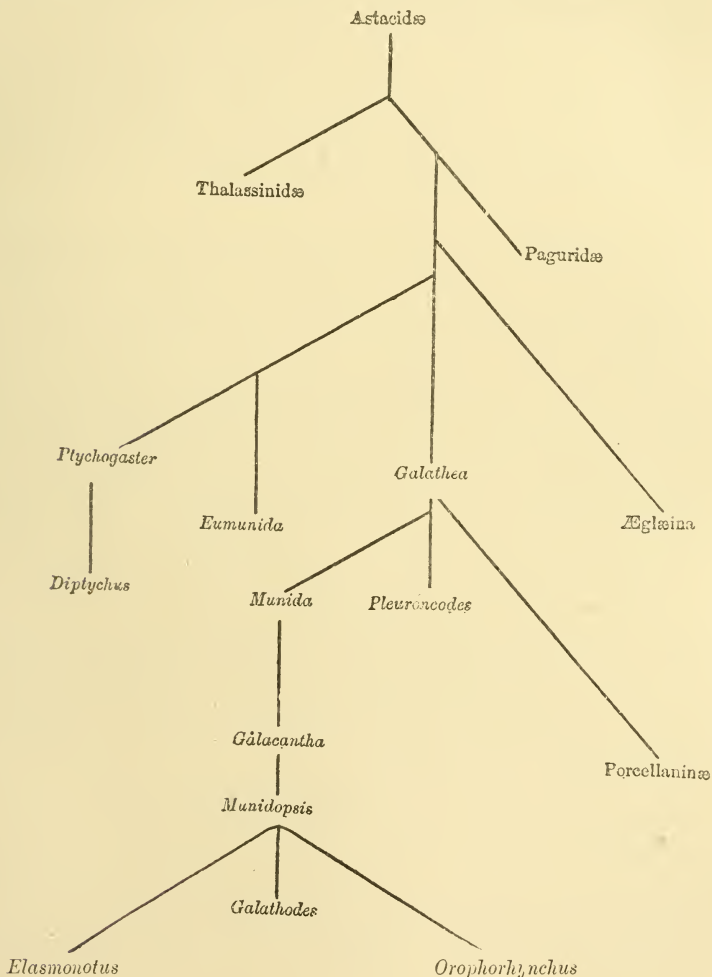

The group is one, the members of which are, like the Paguridæ, essentially plastic, and adaptational influences have acted on them with

\* Ann. Sci. Nat., lix. (1894) pp. 191-327 (36 figs.).

great intensity, though some of the organs have escaped. The eyes and antennæ have especially felt the influence of the surrounding medium; the influence on the carapace has been less definite and is less easy to explain, and much the same is true of the abdomen. The oral appendages seem to have been affected more by a general law of evolution than by adaptation to external influences. The branchial formula of the family is of the same type as that of the Astacidæ.

With regard to coloration the Galatheidæ may be divided into those that can and those that cannot receive visual impressions; in the latter colour may entirely disappear.

The ova vary greatly in size; when numerous they are rarely more than half a millimetre in diameter; the ova of the blind species are ordinarily larger, and those of *Diptychus* and *Ptychogaster* are often 2 mm. in diameter. The development of the former of the two just-named genera has been followed out, and seen to closely resemble that of the Crayfish, as described by Reichenbach.

After discussing the details of the sub-groups and of the genera a table is given to show the chief characters.

The geographical and bathymetric distribution is next considered; as to the latter, it is pointed out that there is not in the whole of the Animal Kingdom, a family which presents more variety than this. It has representatives at all depths, and in fresh water they are represented by a single species. The authors come to the conclusion that the deep-sea Galatheinæ are exclusively represented by an important section of the species which are furthest removed from the macrurous type (blind Galatheinæ); in proportion as the littoral is approached these species yield to others which are less removed from the primitive forms, and, in the sublittoral zone, they are replaced by others which are still nearer; in this same there is met with the other section of the species furthest removed from the Macrura (Porcellaninæ), and these species predominate and become more and more numerous as the littoral is approached.

These conclusions are, of course, the exact opposite to those to which the same authors were led by a study of the Paguridæ, whether they learnt that the Pagurid fauna of the deep is chiefly constituted by species more or less near the macrurous forms, and that these species disappear as the littoral is approached, where they yield to others which are further removed from the primitive types. As the authors well remark, these very divergent conclusions show with what prudence we must try to generalize about abyssal animals.

The authors conclude a very interesting essay with some observations on the geographical distribution of the family.

**Lomisinæ.**\*—M. E. L. Bouvier forms this new group of Anomurous Crustacea for the genus *Lomis*, which has not, he thinks, any direct affinities with the Lithodinæ, but forms an independent subfamily of the Paguridæ. The structural resemblances to *Mixtopagurus* and *Paguristes* are pointed out, while the differences from the Pagurinæ are likewise insisted on.

It is believed that the Lithodinæ are derived from *Eupagurus*, that is to say from Crustacea in which a long adaptation to pagurid life has made the abdomen very unsymmetrical, reduced to a vestige the dorsal

\* Comptes Rendus, cxviii. (1894) pp. 1353-5.



plates, and cause the disappearances of all but the last of the appendages on the right side of the body. *Lomis*, on the other hand, is descended from forms that have been but slightly modified by pagurid life, and retain parts which are lost or vestigial in the Lithodinæ. The Paguridæ, therefore, may be divided into the Paguriinæ, Lithodinæ, and Limosinæ.

**Habits of *Pilumnus hirtellus*.**\*—M. E. G. Racovitza has found this Crab in comparative abundance near Banyuls. He describes some observations which prove that the creature finds its prey by hearing, and not by sight; indeed, it does not seem to use its eyes. It has the sense of direction largely developed, but it is clear that it acts by instinct and not by intelligence.

***Thelphusæ* from Eastern Africa.**†—Prof. F. Jeffrey Bell calls attention to three species of *Thelphusa* from Eastern Africa, and points out that their range would seem to indicate that the line of demarcation between North and South Africa lies south of Mount Elgon, and north of Kilimanjaro; the distribution of some Mollusca appears to favour this view.

**Entomostraca of Wanstead Park.**‡—Mr. D. J. Scourfield records the results of observations made during the three years 1890–91–92 on the Entomostraca of Wanstead Park, an enclosed part of Epping Forest. The total number of species found was sixty, being about two-fifths of the whole freshwater forms at present known to be British. One of the Ostracoda is new to science. The periodicity of many species, including some Copepoda and Ostracoda, is shown and special attention drawn to the seasonal distribution of the Cladocera, the species of which appear to reach their maximum development at Wanstead Park in September, and their minimum in January. The time of appearance of males and ephippial females is also noted and compared with that of the parthenogenetic females. Tables are appended giving the details upon which the results are based.

### Vermes.

#### a. Annelida.

**Habits of *Amphictenidæ*.**§—Mr. A. T. Watson, who has had several specimens of *Pectinaria* or *Lagis* under observation, reports that the worms buried themselves more or less completely in the sand, entering it by digging with their combs (as with a fork), and making a passage through which the wide portion of the tube first passed; the narrower end is frequently left projecting from the sand, and by it the refuse of the animal is expelled. The head-bristles or "golden curls" are used not only for the purpose of digging, but also, probably, for sifting the sand, and thus enabling the animal to select food and suitable material for building. Digging goes on all day.

The author thinks that each tube is the lifework of its tenant, and that it is not shed from time to time, for the following reasons; it appears to take a very long time to construct, the small end is often so minute that it was, evidently, formed when the worm was very much

\* Arch. Zool. Expér., iii. (1894) pp. 49–54.

† Proc. Zool. Soc. Lond., 1894, p. 166.

‡ Journ. Quek. Micr. Club, v. (1893) pp. 161–178.

§ Ann. and Mag. Nat. Hist., xiv. (1894) pp. 43 and 4 (1 fig.).

younger, and it increases gradually in diameter towards the growing edge; there would be no necessity for and but little advantage in shedding the tube.

**Free Nerve-endings in the Epithelium of the Earthworm.\***—Dr. A. Smirnow finds, by using Golgi's method or a modification of it, that the epidermic epithelium of the earthworm contains besides Lenhossek's sensory, terminal nerve-cells, a system of free nerve-endings. These intra-epithelial nerve-threads branch in dendritic fashion. A sub-epithelial plexus is formed from the tree-like endings of the above-mentioned threads, from the axis-cylinder processes of Lenhossek's cells, and from the protoplasmic processes of the same elements. The motor and the sensory fibres can be traced into the ventral chain of ganglia; the axis-cylinder processes of Lenhossek's cells and the free-ending nerve-fibres are quite independent and do not anastomose. The freely ending intra-epithelial fibres are probably secretory as well as sensory, for some form a meshwork around the mucus cells. Smirnow also describes nerve-endings in the epithelium of mouth and gut, besides nerve-fibres and processes spun around the blood-vessels, perhaps vasomotor in function.

**Oligochæta of Eastern Tropical Africa.†**—Mr. F. E. Beddard finds that at present tropical Africa furnishes the most remarkable and interesting representatives of the terrestrial Oligochæta. The Eudrilidæ are almost confined to the Ethiopian region, and abound principally in the equatorial region; the east and west are, as a rule, inhabited by different genera, and always by different species. Mr. F. Finn has collected in Zanzibar and Mombasa thirteen species at least, of which eight are now described as new.

These are *Eudriloides Cotterilli*, *E. brunneus*, *Polytoreutus violaceus*, *P. Finni*, *P. kilindinensis*, *Pareudrilus* (g. n.) *stagnalis*, *Gordiodrilus zanzibaricus*, and *Alluroides* (g. n.) *Portagei*. In the regions visited the most abundant form appears to be *Stuhlmannia variabilis* of Michaelson. Some of the species were found in or at the margin of swamps, and their aquatic character is spoken to by the total absence of dorsal pores, whereby the Eudrilidæ may be distinguished from the majority of "earthworms."

After describing the new forms in detail, the author discusses the nature of the calciferous glands in the Eudrilidæ, and the substitution of organs as illustrated by their spermatothecæ; these worms have cœlomic sacs which do duty as spermatothecæ, and we have proof that the spermatotheca of *Heliodrilus* yields up, in a series of genera, its place to the sac developed out of the mesoblastic tissues, which grows as it diminishes, and finally entirely replaces it.

Provisionally, the Eudrilidæ may be divided into two subfamilies; in the Eudrilinæ there are calciferous glands, generally integumental sense-organs, and the funnels of the sperm-ducts are dilated proximally; in the Pareudrilinæ the calciferous glands are absent or greatly modified, integumental sense-organs are very rare, and there is no dilatation of the sperm-ducts.

\* Anat. Anzeig., ix. (1894) pp. 570-8 (3 figs.).

† Quart. Journ. Micr. Sci., xxxvi. (1894) pp. 201-69 (2 pls.).

New Genera of Earthworms from Western Tropical Africa.\*—Mr. F. E. Beddard describes *Millsonia* (*M. rubens*, and *M. nigra* sp. n.) and *Nannodrilus* (*M. africanus* sp. n.) from Lagos. Both genera are Cryptodrilid, and so belong to a family which is not known to be well represented on the African continent. *N. africanus* seems to be exceedingly common.

Anatomy and Development of some Earthworms.†—Prof. A. G. Bourne describes two new Perichætidæ, one of which he calls *Mahbenus imperatrix* and the other "*Perichæta*" *pellucida*, though he feels sure it is not a true *Perichæta*.

He has some notes on the development of setæ, and points out that those which first appear are embryonic, and that they are succeeded by permanent setæ; his notes on the development of the nephridia deal chiefly with the stages that have a special bearing on the so-called plectonephric condition; he is of opinion that this condition must be regarded as very doubtful, and Beddard's figures in confirmation are severely criticised. Prof. Bourne states that, in spite of repeated and most careful search, he has never been able to see any connection between one nephridium and another in the adult.

*Moniligaster*. ‡—Prof. A. G. Bourne gives a detailed account of *M. grandis*, and has notes on other species of the genus. The author now finds himself able to offer further generalizations with regard to the vascular system of earthworms. He is able to recognize: (1) arteries which carry blood from the main trunks towards capillary networks; these arise from the main tissues, and then repeatedly subdivide; (2) veins which carry blood from capillary networks to main trunks; these are formed by the repeated junction of smaller vessels, and finally open as single large vessels into a main trunk; (3) veins which, like the vertebrate portal veins, carry blood from one capillary network to another; these are vessels or networks of vessels, the branches of which all repeatedly subdivide until they become capillaries, and these are spoken of as a portal system.

The most important distinction which the author finds in the vascular system of worms lies in the presence or absence of this portal system. When it is present there are no intestinal arteries, when it is absent they are present. There is no portal system in *Moniligaster* or *Lumbricus*, while it has been found in all the Perichætidæ examined, and is doubtless present in a number of other genera.

The character which appears to be of next importance is the presence or absence of a subneural trunk, and it may or may not coexist with a portal system.

The resemblances of the gonads of *Moniligaster* to those of various lower Oligochæta is very striking; the testes belong to segment ix. and the ovaries to segment xi.; there are no rudiments of gonads in any other segment.

Prof. Bourne discusses, on the basis of his own experience, the value of various characters for systematic purposes; colour has a certain

\* Proc. Zool. Soc. Lond., 1894, pp. 379-90 (3 figs.).

† Quart. Journ. Micr. Sci., xxxvi. (1894) pp. 11-33 (4 pls.).

‡ Tom. cit., pp. 307-84 (7 pls.).

value; size, even in adults, may vary within 25 per cent.; the position of the rows of couples of setæ is a very good specific character; the body-wall is thickened at the sides in the ophidioid group, enabling them to move very rapidly in a serpentine manner; the number of the gizzards with the particular segments in which they occur, although subject to a considerable amount of individual variation, is to a certain extent a good specific character; a typhlosole is never present. For the generative organs the most valuable character is to be found in the copulatory pouch.

The following new species are diagnosed—*Moniligaster naduvata-mensis* from Naduvatam, Nilgiris, 6000 feet; *M. nilamburensis* from Nilambur, near the sea-level; *M. pellucida*, *M. chlorina*, and *M. ophidioides* from Ootacamund; the ophidioid forms are all strong and active, and the body when at rest is somewhat flattened; they live in swamps and wet ground, and there seems to be a marked tendency towards making hybrids; *M. parva* was found at Ootacamund. The author concludes with some notes on previously described species.

#### B. Nemathelminthes.

**Nematodes and Sugar Cane.**\*—Mr. N. A. Cobb gives an account of the round worms found in fields in which sugar cane is grown in New South Wales. Thirty species belonging to fourteen genera were found; of the latter there are three that are new—*Brachynema* (*B. obtusa* sp. n.) combines some of the characteristics of *Tylenchus*, *Onyx*, and *Dorylaimus*; *Neonchus* (*N. longicauda* sp. n.) possibly stands between *Mononchus* and the spear-bearing genera; *Chaolaimus* (*C. pellucidus* sp. n.) is described from a single immature female. No one species was found in sufficient numbers to justify the fear that it does any serious amount of damage, and not one was seen that appeared to be parasitic.

**Conducting Element in the Muscle-fibres of Ascaris.**†—Professor S. Apáthy recently described his discovery of primitive fibrils, which enter into the muscle-fibres of *Ascaris*, in part traverse them, and are continued into the subcuticular layer. He regarded these as the conducting elements. Dr. E. Rohde ‡ has advanced four reasons for rejecting this discovery, to which Apáthy in turn responds.

**Filariosis in Europe.**§—Dr. M. Font y Torné describes the first known case of *Filaria sanguinis hominis* occurring in Europe. The sporadic case occurred at Canet de Mar, between Barcelona and the French frontier. The whole subject of Filariosis is also discussed.

**Helminthological Notes.**||—Sig. P. Sonsino describes from the intestine of *Chamæleo vulgaris* two new species of *Distomum* (*D. sanguineum* and *D. tacapense*) and an uncertain Nematode. He found *D. tacapense* also in the intestine of the edible frog and toad. In the frog were also found, *Nematoxys commutatus* (in the intestine), *Rhabdonema nigroveno-*

\* 'Plant Diseases and their Remedies' (Department of Agriculture, Sydney) 1893, 8vo, pp. 31-56, figs. 29-46.

† Arch. f. Mikr. Anat., xliii. (1894) pp. 886-911 (1 pl.).

‡ Zool. Anzeig., xvii. (1894) pp. 38-47.

§ Ex. Rev. Ciencias Medicas Barcelona, Nos. 4 and 5, 1894, 20 pp. (1 pl., 1 fig.).

|| Atti Soc. Tosc. Sci. Nat., ix. (1894) pp. 110-16.



sum R. (in the lungs), and a larva of *Olostoma* encapsuled in the muscles and connective-tissue.

γ. Platyhelminthes.

French Nemertinea.\*—M. L. Joubin has contributed to the series called 'Faune Française' a volume treating of the Nemertean worms found on the coast of France. A general account is given in order to enable the student to understand the morphology and chorology of the group, and to know how to seek for and how to preserve these worms. This is followed by a special account of the species, of which ninety-five are recognized. This is a number which exceeds what one might have expected, but it is to be remembered that the French coasts exhibit very great differences.

Turbellaria-Fauna of Basle.†—Herr O. Fahrman has found 33 rhabdocæle and five dendrocæle Turbellaria in the neighbourhood of Basle. Four new species of *Mesostomum* have been found, and a number of new forms of *Vortex*. *Emea lacustris*, the freshwater Nemertine lately found by Duplessis ‡ near Geneva, has also been found near Basle.

New Tristomid.§—M. P. Cerfontaine describes a new Tristomid taken from the gills of *Raja batis* from Ostend; on account of the great complication of the posterior sucker, and the translucency of the living worm, he calls it *Merizocotyle diaphanum*. It is about 6 mm. long and 1.5 mm. wide; the hinder sucker is proportionately large, is fixed in a short stalk, and is nearly circular in form; its concave face is broken up into a number of chambers, of which one is central, six intermediate, and eighteen peripheral; of these last the posterior is curiously produced forwards and upwards, so as to extend on to the dorsal surface. The central and intermediate chambers are surrounded by a muscular pad; a number of hooks, of two sizes, are found on the suckers. The most striking point about the muscles is their transverse striation. Short notes are given, in this preliminary communication, on the digestive and reproductive organs, and the systematic position of the new genus is shown in the accompanying table:—

Monogenea ..	{	Temnocephalæ	-	-	-	{	Tristomidæ	-	-	-	{	<i>Calicotyle</i> .
		Tristomæ	-	-	-		Monocotylidæ	-	-	-		<i>Monocotyle</i> .
		Polystomæ	-	-	-		Udonellidæ	-	-	-		<i>Merizocotyle</i> .

Striated Muscular Fibres in a Trematode.¶—M. P. Cerfontaine devotes a special note to this trait in the subject of the foregoing note; after a brief description of the histological appearances, he reminds the reader, as so many have done before him, of the brothers Hertwig's division of the Coelomata into Pseudocœlida and Enterocœlida, and points out that while the Trematodes are typical members of the first group, the muscles exhibit the structure characteristic of the second. He reminds the student, further, that Marshall proved the possession of fibrillar muscular elements by *Helix* and *Pecten*, which belong to the Pseudocœlida; moreover, Van Beneden and Julin have described,

\* 'Faune Française. Les Némertiens,' Paris, 1894, 8vo, 235 pp., 4 pls.

† Zool. Anzeig., xvii. (1894) pp. 133-5.

‡ See ante, p. 202.

§ Bull. Acad. Roy. Belg., lxiv. (1894) pp. 936-48 (6 figs.).

¶ Tom. cit., pp. 949-54 (3 figs.).

in *Clavulina*, muscular elements which are of the type of the primitive bundles of Vertebrates, and yet are of mesenchymatous and not epithelial origin. Whether it was necessary to put another nail into the coffin of the Hertwigs' theory is another question.

**Development and Formation of Excretory Canals in Cercaria echinata.\***—M. J. Chatin has studied these canals in the larva of *Distomum echinatum*, which dwells in aquatic Molluscs. The first sign of a future canaliculus is a small band of small cells, with relatively large nuclei. Soon the cells seem to fuse, their boundaries disappear, and a kind of plasmodium results; this exhibits great activity, as is shown by nuclear proliferation; the number of nuclei increases, and indicates the beginning of the third period which corresponds to the appearance of the canal proper. In a section parallel to the long axis of the plasmodial band a conical space is seen, while in a section at right angles to this there is seen a narrow cavity with sinuous edges.

These observations show that the views generally accepted do not hold universally; the formation of excretory canals is not always brought about by the perforation of a column of cells; nuclear proliferation plays an important part, and, with protoplasmic activity, succeeds in realising organic conditions which are necessary for the working of the apparatus.

**Anatomy of Tæniidæ.†**—Herr M. Lühe has been investigating the structure of the rostellum and the musculature of the scolex of the Tæniidæ, and gives a preliminary account of his results. The lately established subfamilies of the group appear to have a characteristic type of structure. With regard to the rostellum of the Cystotæniidæ little can be added to the statements of Nitsche and Leuckart; the cells seen by the former in the bulb of *T. crassicolis* are ganglionic.

The rostellum of the Cystoidotæniinæ consists of two muscular sacs with an internal circular and an external longitudinal layer of muscles, though the latter may be wanting; in *Dipylidium* and some avian *Tæniæ* the whole outer sac is absent. The rostellum of the Davaineidæ is an oviform or lenticular body which essentially consists of longitudinal muscles imbedded in a layer of connective-tissue. Tæniæ of Fishes sometimes, at any rate, have merely a rudimentary lenticular rostellum. Intermediate stages between these types have not been found as yet.

The author has seen nothing which leads him to suppose that the rostellum ought to be considered as a modified rudiment of the enteron, but the test of developmental history has not yet been applied to the question. The axial muscular cone of the Anoplocephalinæ consists of stellate crossing fibres which serve to withdraw the suckers from the pits at the base of which they lie when in a condition of rest, and to flatten them out at the same time; these are best developed in *Anoplocephala perfoliata* and *A. decrescens*. *Mesocestoides litterata* has muscular fibres in the scolex which similarly connect the suckers with one another. The muscular cones give as little support as the rostellum to the view that they are the remains of a pharyngeal musculature; they would

\* Comptes Rendus, cxviii. (1894) pp. 1356-8.

† Zool. Anzeig., xvii. (1894) pp. 279-82.

rather seem to belong to the body-musculature, and to have been specially differentiated from them.

In adult scolices, at any rate, there are no intermediate stages between the rostellum and the muscular cone, though the organs are, no doubt, homologous. The innervation of the rostellum is effected by very fine nerve-fibres which can be rendered visible by gold.

*Ligula as Food in Italy.*\*—Dr. F. S. Monticelli points out that though Italians may eat *Ligula* with the piscine host that contains it they do not make a special dish of it, as is generally supposed.

#### δ. *Incertæ Sedis.*

**Development of *Balanoglossus.*** †—Mr. T. H. Morgan gives the details of his investigation. The general phenomena of growth as shown by *Tornaria* present a remarkable series of changes. During the earlier stages an immense increase in size takes place; as the digestive tract does not increase to nearly the same extent as the walls of the body, the space between the walls is much larger than at first.

In the second phase of larval growth a continuous decrease in size takes place, but during this period no new organs are formed. In the third period there is again increase, but this takes place in all the organs simultaneously, and not, as in the early stages, at the expense of one set of structures only. One fact which the author regards as of capital importance is that the increase in length of the young worm is due to a general interstitial growth; the elongation of the posterior metamere is not due to apical growth.

With regard to the metamerism of *Balanoglossus* it is considered as having three pairs of body-cavities, separated from one another by transverse septa with double walls. It is suggested that if the creature was shortened, the proboscis changed into a pre-oral lobe, and the posterior region made of the same length as the collar, no one would doubt that we were dealing with a metameric animal of three segments. If we look upon *Balanoglossus* as a form profoundly modified to fit it for life in the sand, regard the proboscis as a pre-oral lobe (and head-segment) enlarged as a boring organ, and the posterior metamere immensely prolonged, we cannot escape the conclusion that *Balanoglossus* is metameric.

As it may be said that the collar-pores and series of gill-openings arise from a pair of invaginations of the ectoderm the question arises whether this pair of invaginations may not be looked upon as the beginning of an atrium. Merely throwing out this suggestion the author notes the resemblances between *Amphioxus* and *Balanoglossus*, and urges that the characters of the gill-slits point to a common origin for them and for Ascidians.

Comparing his New-England forms with others Mr. Morgan remarks that in them the collar-cavities arise each from a single proliferation of endodermal cells, and the third pair of body-cavities arise as solid evaginations from the endoderm; in the Bahama form, on the other hand, the collar-cavities and the last pair of cavities have a mesenchy-

\* Extract from Boll. Soc. Natural. Nap., viii. (1894) fasc. 1, 3 pp.

† Journal of Morphology, ix. (1894) pp. 1-86 (6 pls.).

matous origin, and come from many scattered cells united secondarily. It follows that the sharp lines drawn by speculative morphologists as to enterocoels, schizocoels, and blastocoels are fading out as evidence comes in. "Phylogenetic speculations of far-reaching and of supposed fundamental import, based on the origins of mesoderm in different groups, are losing their hold as facts accumulate."

With regard to the nerve-cord, Mr. Morgan believes that it is a great error to speak of the invaginated dorsal cord of *Balanoglossus* as equivalent to the whole of the dorsal cord of the higher Chordata, because this cord in *Balanoglossus* stretches through only a single metamere of the body, and does not give off and receive nerve-fibres along its length. It corresponds, therefore, to the anterior end only of the nerve-cord of *Amphioxus*, the homologue of the rest of which is to be looked for in the superficial dorsal nerve-tract which stretches through the gill-region to the end of the body.

**Pedalion.\***—Herr K. M. Levander gives a full and detailed account of the structure of *P. fennicum* which he constantly compares with *P. mirum*. With regard to the wider question of the origin of the Rotatoria and their relations to the Crustacea, and to the Trochophore-larva he sides with Dr. Plate rather than with Prof. Lankester, recognizing that the appendages of this Rotifer are not confined to the ventral surface, and that they may be unpaired. He considers, indeed, that they are rather secondary structures, for in other points of the organization of *Pedalion* he finds nothing essentially different from the Rotatorian type. He dismisses with a word Daday's attempt to homologize the digitate appendages of the hinder end of *P. mirum* with the furca of Nauplius. The development of arthropod-like extremities traversed by muscles must be looked upon as an example of the phenomena of convergence.

**Rotatoria of Michigan.†**—Mr. H. S. Jennings has a report on the Rotifers of the Great Lakes and of some of the inland lakes of Michigan. In the enumeration of the 122 species Hudson and Gosse's monograph has generally been followed; of these species six are new; they are *Notops laurentinus*, *Notommata monopus*, *N. truncata*, *Mastigocerca lata*, *Rattulus sulcatus*, and *Salpina macrocera*.

It is curious that the two common forms, *Lacinularia socialis* and *Hydatina senta*, which are reported from almost everywhere, were never found in the waters examined by the author.

#### Echinoderma.

**Hæmal and Water-vascular Systems of Asteroidea.‡**—Mr. H. C. Chadwick, at the suggestion of the late Prof. Milnes Marshall, undertook a re-examination of the vascular system of Starfishes, based on a study of *Asterias*, *Cribrella*, *Astropecten*, and *Asterina*. He states his results, and compares them with those of the numerous previous workers on the subject.

\* Acta Soc. Faun. et Flor. Fenn., xi. No. 1 (1894) 33 pp., 1 pl.

† Bull. Michigan Fish Comm., No. 3 (1894) 34 pp., 1 [double] pl.

‡ Trans. Liverpool Biol. Soc., vii. (1893) pp. 231-44 (4 pls.).



## Cœlentera.

**Gastrodes.\***—Herr K. Heider, who has had the opportunity of examining for himself the structure of this parasitic Ctenophore, essentially confirms the statements of Korotneff, its discoverer, regarding its structure and histology. The agreement with the young stages of Ctenophores is such that he can find no obstacle to considering it as a parasitic Ctenophore, the development of whose apical sensory organ and ciliated plates has been suppressed in consequence of its mode of life. Its presence in *Salpa* appears to be the cause of sterility in the host; how the parasite feeds is not certain, but it may be supposed to take up the nutrient juices diffused in the body of its host.

**Craspedote Medusæ of the Plankton.†**—Dr. O. Maas adopts Hæckel's general classification with a slight modification from Vanhöffen. He naturally gives precedence to the Trachylinæ (Trachomedusæ and Narcomedusæ), which are pelagic forms *par excellence*, and has less to say of the Leptolinæ (Leptomedusæ and Anthomedusæ). In dealing with species he has taken pains to utilise what is known of the ontogeny of the forms in question.

Among forty-six species captured, the following are named as new:—*Trachynema longicentris*, *Marmanema velatoides*, *Rhopalonema striatum*, *Aglantha occidentalis* or *A. digitalis* var. *occidentalis*, *Liriope distanogona*, *L. compacta*, *L. minima*, *L. hyperbolica*, *Solmaris multilobata*, *Pegantia dactyletra*, *Cunina duplicata*, *Solmundella Hensenii*, *Halopsis megalotis*, *Ptychogena longigona*, and *Tiara prismatica*. At least ten of these are certainly new species. Two new genera are also established—*Homæonema* and *Pantachogon*, both included meanwhile within the family Trachynemidæ. In the former the tentacles are all uniform, but, instead of being definite in number, corresponding to the radial canals, they are numerous (32–64 or more). In the more primitive and divergent *Pantachogon* the gonads are not localized in definite portions of the radial canals, but occur as irregular vesicles over their whole course; the tentacles are numerous and uniform. Apart from the description of these new forms, Dr. Maas has many notes of systematic interest in regard to readjustment of generic limits and diagnoses.

Of 126 Plankton-catches, 116 contained Medusæ, and only 9 of the 116 contained littoral forms; in 88 catches with the vertical net only 18 included littoral forms; in 18 of the same there was but one littoral form to 120 pelagic medusoids. In short, the thoroughly pelagic nature of the captures was conspicuous. Probably the more delicate musculature of the sub-umbrella and velum unfits the coast forms for the open-sea conditions in which the medusoids with direct development flourish.

In regard to the quantitative distribution of the Craspedota the author is cautious. More material is required. He gives tables, however, showing certain facts, such as the absence of Medusæ from the south point of Greenland to the Labrador Stream; the very uniform distribution of certain forms, e. g. *Rhopalonema velatum*, over wide areas;

\* SB. Ges. Nat. Freunde Berlin, 1893 (1894) pp. 114–9 (2 figs.).

† Die Craspedoten Medusen der Plankton-Expedition, Kiel u. Leipzig, 4to, 107 pp., 6 pls., 2 maps, 3 figs.

and the almost constant presence of some representative in every catch, except in the restricted area mentioned above. Taking detailed account of certain species, Dr. Maas discusses their geographical distribution, and endeavours to map out certain pelagic districts; he allows, of course, that more experience is required before we can be secure about these, but points out how his districts agree with those which other investigators of Plankton-organisms have defined. In regard to the vertical distribution, the author is again very guarded in his statements; he indicates the difficulty of the problem and the various methods of solving it; his facts, so far as they go, prove that a number of superficial pelagic forms may retreat several hundred metres beneath the surface, perhaps avoiding warmth, increased salinity, the force of the waves, and the like. If there are any deep-sea Craspedote Medusæ, they must be, he thinks, only Polypomedusæ.

Finally, Dr. Maas alludes to various interesting problems:—How are the periodic variations connected with sexual periods? Whether are Trachylinæ or Leptolinæ the more primitive? Is the gelatinous mesogloea a protective adaptation, a “starvation-tissue,” or an economical surface of insertion for the musculature? What are the bionomic relations of the Craspedota to other organisms and to the general *Stoffwechsel* of the ocean?

**New Veretillid.\***—Dr. G. H. Fowler describes, under the name of *Cavernularia malabarica*, a new sea-pen from Calicut, which is remarkable for the great breadth of the rachis, and the sharpness of the curvature by which this is marked off from the stalk. It would seem to be most nearly allied to *C. luetheni*.

**Origin of Sex-Cells in Hydractinia.†**—Miss M. Bunting, who has investigated the origin of the sex-cells in *Hydractinia* and *Podocoryne*, as well as the development of the former, finds that the gonophore of *Hydractinia* is formed by a protrusion of the ectoderm and endoderm, caused by a multiplication of cells in both layers. The ova appear to be of endodermal origin, while the spermatozoa are of ectodermal origin. The medusa-bud of *Podocoryne* has a similar origin to the gonophore, and the generative products have the same origin as in *Hydractinia*.

The two polar globules leave the surface of the egg of *Hydractinia* at the beginning of segmentation; this is total and equal; the endoderm originates by multipolar delamination, and the coelenteric cavity is due to breaking down of endoderm cells; the mouth is formed by this cavity breaking through to the exterior. The tentacles appear as solid endodermic outgrowths surrounded by endoderm. The hydrorhiza appears first as a stolon-like outgrowth, but later becomes tubular.

#### Porifera.

**Generic Nomenclature of Bowerbank's British Sponges.‡**—Dr. R. Hanitsch refers to the universal refusal of Spongologists to accept the late Dr. Bowerbank's generic nomenclature and classification. He has attempted to assign all the species described by that writer to their proper genera, as the latter are at present accepted.

\* Proc. Zool. Soc. Lond., 1894, pp. 376-9 (1 pl.).

† Journ. Morphol., ix. (1894) pp. 203-36 (3 pls.).

‡ Trans. Liverpool Biol. Soc., viii. (1894) pp. 173-206.

## Protozoa.

**Plastogamy of Actinosphærium.\***—Mr. H. P. Johnson has some notes on this phenomenon, which is characterized by non-fusion of nuclei. As it is a simpler process than karyogamy it may well be regarded as the precursor of nuclear fecundation. The author's observations on *A. Eichhorni* do not differ materially from those of his predecessors. The process is not followed by encystment or any notable reproductive activity; but each instance of fusion is very likely to be followed by division and considerable increase in number within a day or two. It was interesting to observe that the possibility of plastogamy sometimes determined whether a colony should survive. As a result of continued division the *Actinosphæria* became so small that they could not capture their only food—*Bosmina*; the only escape from starvation was coalescence.

**Pliocene Foraminifera.†**—Sig. G. A. De Amicis gives an outline of a forthcoming memoir in which he will describe a deposit of Foraminifera at Bonfornello in Sicily. The deposit is of lower Pliocene age, and has been formed in a sea of considerable but not very great depth. It included representatives of 9 families, 40 genera, and about 163 species and varieties. Globigerinidæ predominated.

**Nuclear Division in Euglena.‡**—Prof. F. Blochmann and Herr Keuten have found a remarkable type of mitosis in *Euglena*. The resting nucleus shows a central body, the so-called nucleolus, surrounded by a mass of minute rod-like bodies, probably bound together by linin-threads. As division begins, the nucleus increases in size, the rod-like bodies become longer curved threads, the "nucleolus" elongates into a rod, and the chromosomes are grouped in an equatorial plate. This divides, as the "nucleolus" elongates, into two daughter-plates; and the whole nucleus acquires a dumb-bell shape. The nuclear membrane still persists. A median constriction separates the halves. The process is most like what Lauterborn has described in Diatomaceæ, the "central spindle" there observed (arising, however, outside the nucleus) having some resemblance to the nucleolar axial rod in *Euglena*.

**Gregarine of Lumbricus herculeus.§**—Mr. W. C. Bosanquet has had the opportunity of studying the Gregarine of the earthworm which was first carefully described by Lieberkühn. The organism is of a pure white colour, quite opaque, and generally spherical in form; mature examples were found to be plentiful in autumn and winter, conjugation occurred about spring, and in summer only cysts and spores could be seen. Granules of paraglycogen were detected in teased specimens; some of the protoplasm was arranged as a continuous capsule, and it is possible that it is an arrangement which is preliminary to spore-formation; spores of two sizes were observed.

**Coccidium in Cattle.¶**—Prof. A. Guillebeau finds that the disease known as *rothe Ruhr* in cattle is associated with the presence of *Coccidium*

\* Journ. Morphol., ix. (1894) pp. 269-76 (4 figs.).

† Atti Soc. Tosc. Sci. Nat., ix. (1894) pp. 117-9.

‡ Biol. Centralbl., xiv. (1894) pp. 194-7 (9 figs.).

§ Quart. Journ. Micr. Sci., xxxvi. (1894) pp. 421-33 (1 pl.).

¶ MT. Nat. Ges. Bern, 1893, pp. 8-14 (1 fig.).

*oviforme*. Zschokke and Hess had already suggested *Coccidia* as a very probable cause of the disease. It seems likely that the hare is instrumental in spreading the disease.

**Endoglobular Parasites of Blood of Vertebrates.\***—M. A. Labbé treats in considerable detail a subject, the beginnings of which start from 1870, when Prof. Ray Lankester described the *Drepanidium* of the frog's blood. Since then Laveran and Danilewsky have worked at the subject. In the Batrachia, *Rana esculenta* is found to be infested with five species, belonging to the genera *Drepanidium*, *Dactylosoma*, and *Cytamæba*, of which the two latter are now for the first time diagnosed. Reptiles are infested by *Hæmogregarina lacertorum* Danil., for which M. Labbé makes the new genus *Karyolysus*; this is found in three species of *Lacerta*, two of which are also infested by *Danilewskyia Lacazei* g. et sp. n.; *D. Stepanowi* is found in *Cistudo europæa*. *Halteridium* g. n. has been found in *Alauda arvensis*, in *Fringilla cœlebs*, in *Sturnus vulgaris* and *Garrulus glandarius*; *Proteosoma* g. n. inhabits the blood-corpuscles of the first two of the just mentioned species of Birds; *Drepanidium avium* is provisionally allowed to stand. Man has been known to be troubled by *Hæmamæba Laverani*. The characters and history of these parasites are very fully described.

The genera are classified in two groups; *Drepanidium*, *Karyolysus*, and *Danilewskyia* being ranged as Hémosporidiés, and *Halteridium*, *Proteosoma*, *Hæmamæba*, *Dactylosoma*, and *Cytamæba* as Gymnosporidiés. The former are characterized by an intraglobular stage of growth which is followed by a free stage in the serum; they have a gregariniform character when adult, and a coccidian endoglobular mode of reproduction by cytocysts. The Gymnosporidia are intraglobular throughout life, are amœboid when adult, and have naked reproductive spores.

With regard to the affinities of these forms the author proposes to divide the class Sporozoa into the Cytozoa and Cytosporidia, which, for some period at least of their lives, lead an intracellular life, and the Histozaa or Histosporidia which are not intracellular, and live in connective, muscular, and perhaps even nervous tissues; the relationship between the two divisions is not close.

The Cytosporidia are thus arranged :

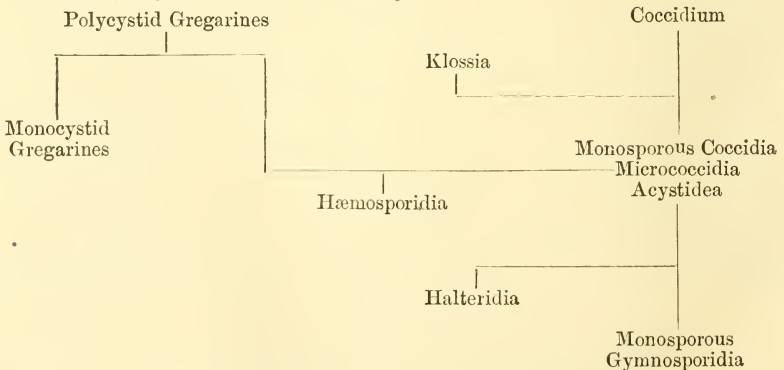

\* Arch. Zool. Expér. et Gen., ii. (1894) pp. 55-258 (10 pls.).



The distinctive characters of these are:—

- (1) The stage of growth is always intracellular.
- (2) A free adult form is only found in Gregarines and Hæmosporidia, and in them there may be conjugation.
- (3) The adult form, which is elongated and mobile in those just mentioned, rounded and immobile in Coccidia, and amœboid in Gymnosporidia, becomes encysted in all but the last.
- (4) Encystation or rounding precedes sporulation; the contents of the cyst divide and give rise to 1 to  $n$  spores; in the interior of each spore 1 to  $n$  sporozoites are formed.
- (5) Gregarines alone have non-intracellular cysts; they are always polysporous.
- (6) The Hæmosporidia always have intraglobular or intracellular cysts, and are always monospores.
- (7) The Coccidia and Gymnosporidia have similar cysts to 6, but may be indifferently mono- or polysporous, and they may, in cases of acute infection, undergo a precocious division.

With regard to the parasitic process the cell is necessary for the development of every intraglobular parasite; infection is effected by reproductive germs or sporozoites; these may penetrate into the organism by the intestine or by the respiratory passages, being carried by air or water. Infection can always be experimentally produced from individual to individual by injection of parasitic blood into the vessels, but not from one species to another. Infection is submitted to certain conditions of immunity, which seem to have some relation to the intensity of infection; phagocytosis, as a means of defence for the organism, is not generally exercised, but in certain cases the leucocytes do acquire a phagocytic power. With the exception of *Proteosoma* and *Hæmamœba*, the parasite rarely has any pathogenic action on the organism; the parasitic action is ordinarily limited to the infected corpuscle; whatever be the changes, such as anemia, the cell easily loses its power of dividing or its special function in the organism. The influence of the blood-medium on the parasite is seen in the simplification of its structure, and by the increase in the number of reproductive germs.

The following generalizations probably apply to all cases of parasitism:—

Parasitic degradation is more marked in proportion as the parasite has less relation with the external medium, and it is marked by these essential characters—simplification in structure and complexity in development, with augmentation of the number of reproductive germs.

**Polytomææ.\***—M. Raoul Francé gives a monographic account of this family, which includes forms approximately parallel morphologically to Chlamydomonads and Volvocinææ, but without chlorophyll and saprophytic. The structure, functions, reproduction, bionomic relations, and classification are all discussed. He ranks the family in the order Volvocinaceæ, sub-order Chlamydomonadinæ, and gives the diagnosis as follows:—Individuals colourless, with a sheath or a thick shell, with 1–4 flagella. Reproduction by 1–3 vegetative divisions, and facultative conjugation. Genera: *Polytoma*, with five species, and *Chlamydolepharis* g. n.

\* JB. wiss. Bot., xxvi. (1894) pp. 205–378 (4 pls., 9 figs.).

Chain-forming *Peridinium*.\*—Herr K. M. Levander describes from Finland seas *Peridinium catenatum* sp. n. which forms, apparently by division, chains of 2-8 and sometimes as many as 16 individuals. A hollowing of the posterior end of the body is regarded as an adaptation to the occurrence of chains. The shell, whose structure is very like that of *P. tabulatum*, is furnished with minute pores, which may be openings for protrusible trichocyst-like threads. These threads have not hitherto been observed in Dinoflagellata, except in the very divergent *Polykrikos*, which has highly differentiated stinging filaments.

Flagella.†—Herr A. Fischer by using Löffler's method has discovered many intricacies in flagella. There are two chief forms in flagellate infusorians—the ciliary flagellum or *Flimmergeissel* and the whip flagellum or *Peitschengeissel*. The ciliary flagellum consists of a homogeneous thread bearing one or several rows of delicate pointed "cilia," as in *Euglena viridis* and *Monas guttula*. The whip flagellum consists of a thick stalk and a twice or three-times longer lash, as in *Polytoma*, *Bodo*, *Chlorogonium*. The forms of flagella are useful as generic characteristics. Their sensitiveness is shown by their being thrown off, and by various changes which have misled some observers. Thus the fragments of a broken lash may hang on the stalk or handle of the whip-flagellum. No retraction was ever seen, but there are various forms of disruption.

Living Parasites in the Blood of Cancerous Persons.‡—Dr. M. Kahane asserts that if pieces of tumours are placed in sterilized physiological salt solution immediately after removal and straightway microscopically examined, bodies endowed with lively characteristic movements may be observed. The movements are such as are only to be explained by the presence of cilia or flagella. The bodies are amœbi-form, highly refracting corpuscles. These micramœbæ are free in the blood-plasma, but may be seen to enter red corpuscles, within which their lively movements continue. When dead they have a roundish contour, and are not to be distinguished from blood-plates. The presence of these bodies resembling swarm-spores suggested to the author that the plasmodium-form might be found. This is described as a body having processes like the sails of a windmill, and was made more visible by means of methylen-blue. The author finds that he is unable to resist the impression that his parasite morphologically and biologically resembles the parasite of malaria.

\* Acta Soc. pro Fauna et Flora Fennica, ix. (1894) 19 pp., 1 pl., 4 figs.

† Jahrb. wiss. Bot., xxvi. (1894) pp. 187-235 (2 pls.). ‡

‡ Centralbl. f. Bakteriöl. u. Parasitenk., xv. (1894) pp. 413-9.



## BOTANY.

A. GENERAL, including the Anatomy and Physiology  
of the Phanerogamia.

## a. Anatomy.

## (1) Cell-structure and Protoplasm.

**Centrospheres of the Nucleus and Size of Cells.\***—From the observation of swarmspores, gametes, and antherozoids, Prof. E. Strasburger concludes that in the cytoplasm two constituents are contrasted in their activity. To one of these, the *kinoplasm*, the radiations round the centrospheres, the spindle-fibres, and the combining filaments (at least in vegetable cells), owe their origin; and it is this which determines the centrospheres of the kinetic centres in the cytoplasm. The other constituent, especially its granular portion, is chiefly serviceable in the processes of nutrition; while its peripheral portion acts as a specific receiver of irritation; this constituent is the *trophoplasm*. Nuclear division takes place under the control of the kinetic centres, the irritation-impacts which proceed from them passing through the kinoplasm.

A specially good example of the various processes is afforded by the internodal cells of *Chara*. While they increase in size the nucleus breaks up into unequal fragments, and the quantity of cytoplasm increases more than a thousandfold; the nuclei increase proportionally in number, because they are necessary for the formation of this enormous mass of cytoplasm. As far as has been observed in the vegetable kingdom, the centrospheres always lie outside the nucleus, and the whole mass of the nuclear spindle is formed of a single substance which occurs outside the nucleus in the cytoplasm. Every nucleus of a typical vegetable cell is accompanied by its centrospheres, and by so much kinoplasm as is necessary for its division, and, in the case of uninucleated cells, for the division of the cell. They form a kinetic unit, an energid in Sachs's sense. In the Algæ and Fungi, the trophoplasm alone takes part in cell-division. It is in the Mosses that the kinoplasm first begins to have a share in the process.

Prof. Strasburger gives a large number of measurements of embryonal cells and of nuclei in vegetable tissues. The variations are very great; in the former case between 0.024 and 0.005 mm.; in the latter between 0.016 and 0.003 mm. The average relation between the size of the nucleus and that of the embryonal cell is nearly as 2 to 3.

**Centrospheres in the Spores of *Pellia*.†**—Prof. J. B. Farmer and Mr. J. Reeves find the spores of *Pellia epiphylla* (Hepaticæ) a remarkably good object for observing the part played by the centrospheres in the division of the nucleus. The best results were obtained with the following double stains used successively:—gentian-violet and orange G, gentian-violet and eosin, anilin-blue and acid fuchsin.

When nuclear division is about to take place, two minute centro-

\* 'Ueb. d. Wirkungssphäre der Kerne u. d. Zellgrösse,' 28 pp., Jena, 1893.

† Ann. Bot., viii. (1894) pp. 219-24 (1 pl.).

spheres appear on the outside of and in contact with the nuclear wall, beautiful radiations extending from them; they are usually diametrically opposite to one another. The centrospheres appear then to pull the nucleus into an elliptical shape; and the chromatin becomes distributed in the form of a narrow equatorial band lying just within the nuclear membrane; it gradually becomes more definitely fibrillar, and finally takes the form of eight chromosomes. The rest of the nucleus is now entirely free from staining substances; it becomes more and more drawn out, and its wall becomes gradually thinner and finally disappears; at this period the achromatic spindle is differentiated. After the separation of the chromosomes from the equator to form the daughter-nuclei, a beautiful cell-plate is formed across the achromatic spindles. The centrospheres appear no longer to retain their individuality within the cytoplasm after the formation of the daughter-nuclei. In some instances irregularities were observed in the process of division, occasionally the appearance of a third centrosphere.

**Function of the Nucleus.\***—Dr. A. Zimmermann gives a very valuable *resumé* of recent researches on this subject, both in the animal and in the vegetable kingdom. He considers it as established that there is the closest relationship between the nucleus and the cytoplasm, neither being able to carry on an independent existence without the other; that the attraction-spheres probably give the first impulse towards the division of the nucleus; that the nucleus is the principal agent for the transmission of hereditary properties; that the phenomena of motility and the division of the contractile vacuoles, and the process of respiration, are not necessarily dependent on the nucleus; while different observers are not in accord as to the necessity of this structure for the growth of the cell-wall and the formation of starch.

The questions of the exchange of material between the nucleus and the cytoplasm, and the formation of crystalloids, are discussed in detail; and a very copious reference given to the literature of the subject.

**Growth of the Cell and Nature of the Nucleus.†**—Herr E. Zacharias has confirmed Schwarz's observation of the increase in size of the nucleus, and of the nucleolar mass, in growing sieve-tubes, hairs, and epidermal cells, and especially in the germinating endosperm of *Ricinus*. In the epiderm of *Galanthus* and *Hyacinthus*, the mother-cells of the stomates are, immediately after division, nearly the same size as their sister-cells; but the latter very soon increase much more rapidly in size. The nucleus of the mother-cell of the stomate is also considerably smaller, and contains a larger proportion of nuclein, than that of the sister-cells, and its nucleoles are very much smaller. Similar differences occur in the male and female sexual cells. The former remain small, and have a small nucleus containing a large proportion of nuclein, and only a small nucleole or none at all. The larger female cell, on the other hand, has a large nucleus containing a small proportion of nuclein and a large nucleole. As a general rule, active growth of the cell is associated with an increase in the number of the nucleoles, but a decrease in the proportion of nuclein which they contain.

\* Bot. Centralbl., 1894, Beih., pp. 81-9.

† Ber. Deutsch. Bot. Gesell., xii. (1894) pp. 103-8.



**Behaviour of the Nucleoles during Karyokinesis.\***—Dr. A. Zimmermann records the results of observations which tend to contradict the prevalent view that the nucleoles are entirely absorbed during karyokinesis, arising again in the daughter-nuclei after metakinesis. The observations were made on anthers of *Lilium Martagon* and *Hyacinthus candicans*, sporanges of *Equisetum palustre* and *Psilotum triquetrum*, embryo-sac and nucellus of *Lilium Martagon*, endosperm of *Fritillaria imperialis*, apex of the root of *Vicia Faba*, apex of the stem of *Phaseolus communis* and *Psilotum triquetrum*. The material was fixed by Merkel's compound and imbedded in paraffin, the sections were stained by a mixture of iodine-green and fuchsin, washed with alcohol containing 1 gr. iodine and 1 cm. acetic acid to 100 cm., the alcohol removed by xylol, and this replaced by Canada balsam. The nucleoles are by this process coloured a deep red, the chromatin globules a deep green or blue or even blue-violet, the cytoplasm remaining colourless or light red.

It was thus demonstrated that bodies appear in the cytoplasm during karyokinesis identical with the nucleoles of the resting nucleus. They are wanting immediately before karyokinesis, and are without doubt the product of the breaking up of the nucleoles. Subsequently these extra-nuclear nucleoles disappear from the cytoplasm, and appear to wander back to the daughter-nuclei, where they coalesce to form the large nucleoles.

These observations appear to negative the hypothesis of a sharp demarcation between the nucleus and the cytoplasm in all stages of karyokinesis. Elaioplasts were detected in the parenchyme-cells of *Psilotum*.

**Nucleoles and Centrosomes.†**—Prof. J. E. Humphrey asserts that the phenomenon, observed by Strasburger and Zimmermann, of the presence of nucleolar substance in the cytoplasm which has been expelled from the nucleus during cell-division, is not universal, and is only of exceptional occurrence. The author's observations were made on mother-cells of pollen and spores, cells from the apex of the root, and the parietal layer of the embryo-sac. The nucleoles he regards, not as a store of reserve-material for the nucleus, but as passive structures, the number, form, and size of which depend on the activity of certain forces within the cell. The vacuoles of the nucleoles are the natural result of the subsequent separation of the more fluid from the more solid portions of the nucleolar substance. The bodies known as "para-nucleoles" are probably artificial products of the action of the fixing material. The body described by Karsten ‡ as the "nucleo-centrosome" is shown, by its reaction with staining reagents, not to be a true centrosphere, but a portion of chromatin. Nucleoles and centrosomes are perfectly distinct substances, having no relation to one another.

**Chemistry of the Cell-wall.§**—Pursuing his observations on this subject, Herr E. Schulze replies to various objections of Gilson against

\* Beitr. z. Morph. u. Phys. d. Pflanzenzelle (Zimmermann), ii. (1893) pp. 1-35 (2 pls.).

† Ber. Deutsch. Bot. Gesell., xii. (1894) pp. 108-17 (1 pl.), and Ann. Bot., viii. (1894) pp. 373-6.

‡ Cf. this Journal, ante, p. 360.

§ Zeitschr. f. Phys. Chemie, xix. pp. 38-69. See Bot. Centralbl., Iviii. (1894) p. 209. Cf. this Journal, ante, pp. 215, 216.

his previous conclusions. True cellulose he finds only in very small quantities in the cell-walls of the seeds of the blue lupin. Gilson's paramannan is probably a product of mannose-cellulose resulting from the absorption of water. The author proposes a classification of the carbohydrates contained in the cell-wall—cellulose, hemi-celluloses, mucus-yielding substances, and amyloid, forming members of a series which pass into one another through intermediate forms. He limits the term cellulose to the substance which yields dextrose; including under the term hemi-celluloses all the rest with the exception of the mucus-yielding substances and amyloid. Under hemi-celluloses must also be included mannose-cellulose, the substance which yields xylose, and Reiss's reserve-cellulose.

**Cuticular Formations.\***—Herr K. Schips describes some peculiar outgrowths of the cuticle in the fruit of *Rohdea japonica* (Liliaceæ). They differ from most similar structures in belonging exclusively to the last-formed layer, in not projecting into the lateral walls of the epidermal cells, and in remaining isolated instead of forming a connected network.

(2) Other Cell-contents (including Secretions).

**Chromatophores.†**—Dr. A. Zimmermann sums up the present state of our knowledge on this subject, referring to all the recent treatises on it. The results are classified under the following heads:—The finer structure of the chromatophores; the chemical and physical properties of their pigments (carotin, xanthin, phycoerythrin, phycophæin, peridinin, &c.); the substances enclosed within the chromatophores (starch-grains, protein-crystalloids, leucosomes); the pyrenoids; the metamorphoses of the chromatophores; the mode of their formation and multiplication. Special details are then given with regard to the structure of the chromatophores in the following classes:—Diatomaceæ, Cyanophyceæ, Zygnemaceæ, Volvocaceæ, Hydrodictyceæ, Ulotrichaceæ, Cladophoraceæ, Botrydiaceæ, Ectocarpaceæ, Florideæ, Filicinæ, and Selaginellaceæ.

**Chlorophyll-grains in Seeds and Seedlings.**—From observations made on *Helianthus* and *Lupinus*, M. A. Famintzin ‡ asserts that the ripe seed always contains chromatophores which have only to become green during germination to produce the chlorophyll-grains in the seedling. They lie partly in the spaces between the aleurone-grains, and partly on their surface and on that of the cell-nucleus. The chlorophyll is formed from a yellow chromogen present in the chromatophores of the seed. Derived from the same chromogen, he finds, in the seed of *Helianthus*, two new pigments, soluble in water, one yellow, the other green. They are nearly allied to xanthophyll and chlorophyllin.

M. E. Belzung § corrects a misstatement of Famintzin with regard to his own observations, and states that the chromatophores of the mature seed are invariably formed from pre-existing starch.

\* Beitr. z. Morph. u. Phys. d. Pflanzenzelle (Zimmermann), i. (1893) pp. 318-22 (5 figs).

† Bot. Centralbl., 1894, Beih., pp. 90-101.

‡ Bull. Acad. Imp. Sci. St. Petersburg, xxxvi. pp. 75-88 (1 pl.).

§ Journ. de Bot. (Morot), viii. (1894) pp. 156-9.

## (3) Structure of Tissues.

**Structure of Aquatic Plants.\***—Prof. K. Goebel describes the adaptations to environment in the structure of many aquatic plants, both flowering and flowerless; such as the formation of large intercellular spaces, the reduction of the conducting tissue and of the mechanical system, the splitting of the leaves, &c. The purpose of the abundant formation of mucilage appears to be not so much the storage of water as protection against animals. Submerged plants agree with shade-plants in the suppression of the palisade-parenchyme. The conduction of air is facilitated by the formation of air-conducting tissue, aerenchyme or pneumatenchyme, or by the occurrence of air-tubes, as in the tubular leaves of *Isoetes*.

**Formation of Mucilage by Aquatic Plants.†**—Herr A. J. Schilling finds the formation of mucilage on the organs still in process of formation to be a general phenomenon in all water plants. The organs which serve this purpose are always morphologically trichomes, but vary greatly in their form. The mucilage is formed at the expense of the cell-wall by the transformation of its outermost layers; the masses of mucilage collecting between the cuticle and the cell-wall. The balls which occur within many mucilage organs, composed of Raciborski's myriophyllin,‡ are not nearly connected with this process. The mucilage serves as a protection for the young organs against immediate contact with water; a subordinate function is performed in the protection against animals and algæ.

The very numerous flowering water-plants examined by the author are arranged in seven groups, viz.:—(1) The mucilage organs are hairs of very simple structure (*Brasenia peltata*, *Cabomba aquatica*); (2) An abundant mucilage is formed in hair-structures which enter into the composition of the bud (*Nuphar luteum*, *Nymphæa alba*, *Euryale ferox*, *Victoria regia*); (3) The lower part of the leaf forms a closed sheath, the inner surface of which is thickly covered with mucilage-hairs (*Ranunculus fluitans*, *Callitha palustris*, *Limnanthemum nymphæoides*, *Menyanthes trifoliata*); (4) The mucilage organs are composed of a larger or smaller number of cells (*Aldrovanda vesiculosa*, *Utricularia vulgaris*, *Callitriche vernalis*, *Myriophyllum spicatum*, *Ceratophyllum demersum*); (5) The leaf forms an ochrea at its base; the whole surface of the young plant is covered with mucilage (*Polygonum amphibium*, *Rumex maritimus*); (6) The mucilage is formed at the margin of sheath-like stipules (Pontederiaceæ); (7) The mucilage-organs are intravaginal scales (*Vallisneria spiralis*, *Hydrocharis morsus-ranæ*, *Elodea canadensis*, *Alisma*, *Sagittaria*, *Potamogeton*, *Zostera*). Some cryptogamic plants also have mucilage-organs, as *Salvinia*, *Marsilea*, *Isoetes*, &c.

**Resin-canals in *Abies pectinata*.§**—M. J. Godfrin describes the course of the resin-canals in the stem of *Abies pectinata*. From the axis they pass to a bud of cortical origin which forms a kind of cup, at the

\* Pflanzenbiol. Schilder., pt. ii. (1893) pp. 215–386. See Bot. Ztg., li. (1893) 2<sup>o</sup> Abtheil., p. 374.

† Flora, lxxviii. (1894) pp. 280–360 (17 figs.).

‡ Vide infra, p. 588.

§ Comptes Rendus, cxviii. (1894) pp. 819–22; Bull. Soc. Bot. France, xli. (1894) pp. 127–9. Cf. this Journal, 1893, p. 60.

base of which the cone of growth is inserted during the winter; they terminate in this bud, which bears bud-scales. The leaves always spring from between two neighbouring canals, and at an equal distance from each of them. The buds referred to are enveloped in lignified scales, which remain as a protection for several years.

**Muciferous and Resiniferous Cells in the Yew.\***—M. L. Mangin has found, in the leaves of the yew, muciferous cells which differ from those known in other plants by the fact that they contain a mass of protoplasm, a nucleus, and grains of chlorophyll. They are especially abundant in the palisade-tissue. This distribution of resiniferous cells through the green parenchyme in the yew is associated with the absence of the resin-canals characteristic of other Conifers.

**Histology of Pontederia.†**—Mr. E. M. Wilcox describes the histology of the stem of an aquatic Monocotyledon, *Pontederia cordata*. Among other features it is characterized by the presence, on each side of the closed fibrovascular bundles, of specialized cells containing starch.

Mr. E. W. Olive ‡ describes several other points in the histological structure of species of *Pontederia* and *Heteranthera*, including continuity of protoplasm from cell to cell in the stellate tissue of the stem of *P. crassipes*.

**Parasitism of Epiphegus.§**—Mr. H. Schrenk describes in detail the structure of *Epiphegus virginiana*, belonging to the Orobanchaceæ, and that of the root of the beech, on which it is parasitic in the United States. The structure of the haustorium and its connection with the host are very complicated, a complete union taking place between the tissues of the two plants.

**Structure and Composition of Galls.||**—Herr M. Küstenmacher compares the general structure of galls to that of fruits. The substances which they contain are, in general terms, the same. In the formation of galls the tissue first affected is the conducting tissue. The substances formed in the largest quantities are tannin, starch, and oxalates. Cellulose is also often stored up, and similar pigments are formed to those which are contained in petals. Galls are generally provided with crevices for the interchange of air, which originate from stomates.

**Root-tubercles of Leguminosæ.¶**—According to Mr. A. Schneider, the root-tubercles of the Leguminosæ bear greater resemblance in anatomical structure to a stem than to a root; they are developed exogenously from a meristem, which surrounds the spots infected by the rhizobe; the cork is formed from a true phellogen. The nuclei in the tubercles of *Phaseolus vulgaris* attain a large size, and delicate prolongations give them an amœboid form; they afterwards burst, and allow the escape of the nuclear substance, which mixes with the cytoplasm.

\* Bull. Soc. Bot. France, xl. (1894) pp. 313-6 (1 fig.).

† Journ. Cincinnati Soc. Nat. Hist., xvi. (1893) pp. 100-4 (4 figs.).

‡ Bot. Gazette, xix. (1894) pp. 178-84 (1 pl.).

§ Proc. Amer. Micr. Soc., xv. (1894) pp. 91-128 (10 pls.).

|| Jahrb. f. wiss. Bot. (Pringsheim), xxvi. (1894) pp. 82-185 (6 pls.).

¶ Amer. Naturalist, xxvii. (1893) pp. 782-92 (1 p.). Cf. this Journal, 1893, p. 774.



**Root-tubercles of *Isopyrum*.**\*—Mr. D. T. MacDougal describes the tuberous thickenings of the fibrous roots of *Isopyrum biternatum*, an American plant belonging to the Ranunculaceæ. The cells of the nodules contain neither starch, nor sugar in its ordinary forms, but numerous organisms of a bacterial nature. The author suggests that these enable the plant to assimilate the free nitrogen of the atmosphere.

#### (4) Structure of Organs.

**Male Flowers of the Box.**†—Dr. F. Cavara discusses the nature of the "central body" in the male flowers of the box. From a careful examination of its structure in *Buxus sempervirens* and in some other species, he concludes that the view of the majority of botanists—that it is a rudimentary female organ—is incorrect. He agrees rather with Delpino's interpretation that it is a nectary closely connected with the opening of the flowers, and with the pollination by means of Diptera and Apidæ. It presents none of the structure of an abortive ovary; its cells do not contain starch, but sugar.

**Anatomy of Petals.**‡—Prof. Luise Müller publishes an exhaustive account of the structure of the corolla in a great variety of flowers, especially those belonging to the Ranunculaceæ, Nymphæaceæ, and Rosaceæ.

With regard to the epiderm of petals, the most common form of cells is the cubical; the lateral walls are very commonly wavy or ribbed, especially on the under side of the leaf; and this is much more generally the case with Dicotyledons than with Monocotyledons. It is by no means most usual for the epidermal cells to be swollen into papillæ; this is more common on the upper than on the under side of the petals. Normal stomates occur not unfrequently; imperfect stomates much more commonly. With regard to the contents of the epidermal cells, the chromoplasts result from the metamorphosis of leucoplasts or chloroplasts. The leucoplasts very commonly contain starch, and chloroplasts are not uncommon. The origin of the various pigments of petals is discussed, especially the connection between a red colour and the presence of tannins. Tannin was almost invariably found, either in the open flower or in the bud, in the epiderm or in the connecting tissue which surrounds the vessels. The authoress believes that the vacuoles are formed spontaneously in the protoplasm, and that their wall is an organic structure formed from the protoplasm. The peculiar structure of the epiderm of petals is especially adapted, in the first place for the attraction of insects, and in the second place for the storing up of water and prevention of excessive transpiration.

The mesophyll of petals is greatly reduced, and is usually destitute of a palisade-tissue. The mesophyll contains, as a rule, but a small quantity of chloroplasts, chromoplasts, and pigments, but often a large quantity of excreta, especially of essential oils. The bud often contains large quantities of starch or glucose, which is more or less completely

\* Minnesota Bot. Studies, 1894, pp. 39-42.

† Malpighia, viii. (1894) pp. 27-40 (1 pl.).

‡ Nova Acta K. Leop.-Carol. Akad. Naturf., lix. (1893) pp. 1-356 (22 pls.).

used up in the development of the flower. The mesotome is in all cases but feebly developed.

The authoress holds that the structure of the petals does not support the theory that they are in all cases abortive or metamorphosed stamens; their great variety of form has resulted from the mutual functions of insects and corolla in bringing about pollination.

**Morphology of the Cabombaceæ and Nymphæaceæ.\***—M. M. Ra-ciborski has studied the morphology of the genera of Cabombaceæ (*Cabomba*, *Brasenia*) and Nymphæaceæ (*Nuphar*, *Nymphæa*, *Euryale*, *Victoria*), and enters into detail with regard to their comparative anatomy, especially that of the growing point. The carpels, sepals, foliage-leaves, and internodes are covered with mucilage-producing hairs which contain a pigment of undetermined composition to which the author gives the name *myriophyllin*. The dorsal mode of attachment of the ovules is peculiar to *Brasenia* and to a single genus of Resedaceæ.

**Embryo of Phanerogams.†**—Dr. R. Schmid has examined the position of the embryo, and the mode in which the first division takes place, in 124 species of flowering plants belonging to 64 orders (57 of Dicotyledons, 7 of Monocotyledons). With regard to terminology, the author applies the term longitudinal axis to the line drawn through the middle of the embryo-sac and the micropyle; median plane to that which passes through the middle of the funicle and the longitudinal axis of the ovule; the anterior part of the embryo-sac is the micropylar end; the median plane of the cotyledons is that which divides each cotyledon symmetrically.

The general conclusions arrived at are that, whatever may be the position occupied by the ripe seed or seeds within the seed-vessel, this does not affect either the position or the anatomical structure of the embryo, and that the relative position in which the various organs are formed in the embryo is independent of its position within the seed.

**Endosperm of Phytelephas and Smilacina.‡**—Mr. J. L. Zabriskie describes the structure of the endosperm of *Phytelephas macrocarpa* (vegetable ivory) and *Smilacina racemosa*. The former shows, on transverse section, concentric circles sweeping round the longitudinal axis of the nut. The latter is composed of a very homogeneous mass of irregularly globular or ellipsoidal cells with greatly thickened cell-walls, and is, like the former, remarkably hard.

**Aerial Roots of Epiphytes.§**—Dr. F. A. F. C. Went has made a comparative study of the aerial roots—performing the function either of attachment or of nutrition—of a large number of tropical epiphytes belonging to many different natural orders. The function of these roots may differ even in species belonging to the same genus.

The attachment may be effected either by long cord-like roots growing nearly horizontally, or by temporary very sensitive roots, or by temporary roots which ramify greatly and form a disc-like structure. The nutritive roots are subject to less variation. The author proposes the term *pseud-*

\* Flora, lxxviii. (1894) pp. 244-79 (9 figs.).

† Bot. Centralbl., lviii. (1894) pp. 1-7, 33-41, 81-9, 113-9 (1 pl.).

‡ Journ. New York Micr. Soc., x. (1894) pp. 14-6 (1 pl.).

§ Ann. Jard. Bot. Buitenzorg, xii. (1894) pp. 1-72 (2 pls.).

*epiphyte* for those plants in which the lower part of the stem entirely dies away, leaving the upper portion to derive its nutriment exclusively through the aerial adventitious roots. This occurs especially among the Aroideæ. Those plants which at first obtain their nutriment entirely from the soil, but at a later period also partially through aerial roots, are termed *hemi-epiphytes*. The order of development he believes to be as follows:—root-climbers, root-climbers with nutrient aerial roots, pseud-epiphytes, hemi-epiphytes, true epiphytes.

### β. Physiology.

#### (1) Reproduction and Embryology.

**Embryo-sac of *Plantago*.**\*—Dr. L. Buscalioni describes the structure and development of the embryo-sac of *Plantago lanceolata*. In addition to some minor peculiarities, it is characterized by the emission of numerous diverticula—filaments of cellulose, each of which contains a portion of one of the original nuclei of the embryo-sac.

**Cross-pollination and Self-pollination.**—Herr P. Knuth † has investigated the phenomena of pollination in plants growing in the marsh-lands of Schleswig-Holstein. Out of 36 species examined, two were hydrophilous, two self-pollinated, 16 entomophilous, though able to effect self-pollination, and the remainder anemophilous.

He also describes ‡ the mode of pollination and the insect-visitors of a number of species, natives of the island of Capri; and § the pollination of the three German species of *Helleborus*; these are proterogynous and entomophilous.

The same author|| discusses the phenomena of pollination in the islands of North Friesland, where there is an almost constant high wind. The number of anemophilous species is here comparatively large, that of entomophilous species being small. The flowers are, as a rule, large.

According to Herr C. Raunkjær ¶ all the hermaphrodite species of Cyperacæ natives of Denmark are so strongly proterogynous that self-pollination is impossible.

In *Pentstemon gentianoides* Prof. F. Pasquale \*\* states that the movement of the staminode is for the purpose of ensuring self- rather than cross-pollination.

In the latest of his series of papers on "Flowers and Insects," Mr. C. Robertson †† describes the mode of pollination and the insect visitors of several American species of *Clematis* and *Ranunculus*, also of *Hypericum cistifolium*, *Xanthophyllum americanum*, and *Rhus glabra*.

\* Malpighia, viii. (1894) pp. 3-13 (1 pl.).

† Bot. Jaarb. Dodonæa, vi. (1894) 31 pp. and a map. See Bot. Centralbl., lviii. (1894) p. 212.

‡ Atti Congr. Bot. Internaz. Genova, 1893, pp. 553-60 (1 pl.). See Bot. Centralbl., 1894, Beih., p. 22.

§ Bot. Centralbl., lviii. (1894) pp. 225-8 (3 figs.).

|| 'Blumen u. Insecten auf den nordfriesischen Inseln,' Kiel, 1893. See Bot. Ztg., li. (1893) 2<sup>o</sup> Abtheil., p. 370.

¶ Bot. Tidsskr., xviii. (1893) pp. 19-23. See Bot. Centralbl., lvii. (1894) p. 142.

\*\* Jahrb. Bot. Gesell. Dodonæa, 1893, 14 pp. and 1 pl. See Bot. Centralbl., lvii. (1894) p. 142.

†† Bot. Gazette, xix. (1894) pp. 103-12.

Herr C. Verhoeff\* describes the adaptation of the flower for cross-pollination, and of the visiting insects, in 75 species of flowering plants growing in the island of Norderney.

**Germination of Pollen-grains.** †—Prof. J. R. Green has made a series of observations on the germination of the pollen-grain and the nutrition of the pollen-tube in a large number of plants belonging to many different natural orders. He finds in the pollen-grain either one or both of two different enzymes, diastase and invertase; these may be extracted by the same treatment as has been found effectual in the cases of seeds and foliage-leaves; the quantity is largest at the period of commencement of germination. The pollen-tube is nourished during its growth by plastic reserve-material derived either from the grain itself or from a secondary store deposited in the style. This consists in different species of different carbohydrates—starch, dextrin, cane-sugar, maltose, and glucose; but dextrin is not found in the style. The style contains a further quantity of enzymes, and the pollen-tube itself excretes the same ferments during its progress down the conducting tissue of the style.

The absorption of food-material appears to be one cause of the increase of enzyme which takes place during germination; and this absorption is usually so active that the reserve-store of the pollen-grain is often largely increased by a temporary deposit, either in the grain or tube, of some of the absorbed sugar in the form of starch.

(2) **Nutrition and Growth (including Germination, and Movements of Fluids).**

**Influence of Light on the Germination of Seeds.** ‡—Contrary to the statement of some previous observers, Herr B. Jönsson asserts, as the result of observations on a large number of plants, that light greatly promotes the germination of seeds, and that the favourable influence is not in any way due to the rays of heat. Seeds of different species vary very greatly in their sensitiveness to light.

**Action of Magnetism on Germination.** §—Sig. G. Tolomei finds, as the result of a series of experiments (on *Phaseolus vulgaris*), that a magnetic field of feeble intensity has no appreciable effect on the germination of seeds; while a field of greater intensity causes a more or less increased rapidity of growth, in proportion to the proximity of the growing plant to the point of greatest magnetic intensity. Young plants are diamagnetic.

**Work and Pressure in Growing Plants.** ¶—Prof. W. Pfeffer has undertaken a series of experiments for the purpose of determining the relations between the energy of the work performed by plants and the pressure exercised upon the organism by external and internal forces. The structures on which the experiments were made were roots and stems, chiefly of *Zea Mays*, *Vicia sativa*, and *V. Faba*, the nodes of

\* Nov. Acta K. Leopold-Carol. Deutsch. Akad. Wiss., lxi. (1893) 3 pls. and numerous figs. See Bot. Centralbl., lviii. (1894) p. 178.

† Proc. Roy. Soc., lv. (1894) pp. 124-7; Ann. Bot., viii. (1894) pp. 225-8.

‡ Acta Univ. Lund., xxix. (1893) 47 pp. See Bot. Centralbl., lviii. (1894) p. 398.

§ Malpighia, vii. (1894) pp. 470-82.

¶ Abhandl. K. Sächs. Gesell. Wiss., xx. (1893) pp. 235-474 (14 figs.).



grasses, and Algæ; and the observations were made by enveloping the organ in question in a thinner or thicker cylinder of gypsum. The power of resistance of growing plants increases in proportion to the resistance to be overcome, and varies so enormously that under certain conditions it may be as much as eighty-one times greater than in others. There is always, however, a limit to this power of resistance. Among Algæ, *Chara*, *Nitella*, and *Spirogyra* retain their power of growth for months within an envelope of gypsum. The nodes of grasses are an especially favourable class of objects for determining the effects of geotropism; since the geotropic tendency of the stem to bend upwards is displayed only in the nodes. In the growing tips of roots of *Faba* a longitudinal pressure of 5-19 atmospheres was measured; in roots of maize one of 9-24 atmospheres, in *Vicia sativa* one of 8-13, and in the horse-chestnut one of 6 atmospheres. In roots of *Faba* the transverse pressure was from 2-6, and in maize 6.5 atmospheres.

**Mechanomorphosis.**\*—Prof. J. Sachs maintains that natural selection can account only for the production of small variations, not for the differentiation of the main divisions of the natural system; the isolation of the larger phylogenetic groups can by no means be explained by the law of the survival of the fittest. By the term *mechanomorphosis* he proposes to express the parallel changes in structure which are brought about in the different large groups by the action of similar external causes. Such is the production of leaf-like structures in Algæ and in Phanerogams by the action of light on a tissue containing chlorophyll. Another example of mechanomorphosis is afforded by the action of the specific size of organisms on their internal structure and external form.† Mechanomorphosis may be of two kinds, *barymorphosis* and *photomorphosis*, according as the principal agent in the changes is gravitation or light. The dorsiventrality of prothallia and the form of leaves are good examples of photomorphosis.

**Propagation of Potamogeton.**‡—M. C. Sauvageau records a series of observations on the mode of growth, and multiplication of various species of *Potamogeton*, especially *P. crispus*, *trichoides*, *pusillus*, *perfoliatus*, *lucens*, *pectinatus*, and *natans*, and on the anatomy of the stem.

The ramification of all species of *Potamogeton* is of the same type:—the rhizome is always a sympode formed by the union of the first two internodes of successive generations; in a few species the rhizome is wanting. In most species the fruit remains for a long time after maturity before germinating. All the species are readily propagated by fragments of the stem which become detached, and often hibernate before undergoing further development. The portion which thus separates itself differs in the different species; and usually presents some differentiation from the rest of the plant in its anatomical structure. In *P. natans* almost the whole plant hibernates in this way.

**Nutrition of Viviparous Mangrove-plants.**§—Herr G. Haberlandt describes a similar structure in other mangrove plants to that already

\* Flora, lxxviii. (1894) pp. 215-43.

† Cf. this Journal, 1893, p. 659.

‡ Journ. de Bot. (Morot), viii. (1894) pp. 1-9, 21-43, 45-58, 98-106, 112-23, 140-8, 165-72 (31 figs.). Cf. this Journal, 1892, p. 63.

§ Ann. Jard. Bot. Buitenzorg, xii. (1893) pp. 91-116 (3 pls.). Cf. this Journal, 1890, p. 65.

known in *Avicennia officinalis*, where the endosperm and embryo project through the micropyle into the ovary, with the exception of certain cells which increase enormously in size, and constitute a haustorium which conveys food-material to the endosperm and embryo.

In *Bruquiera eriopetala* a secondary endosperm-tissue is formed, from which one-celled or many-celled appendages penetrate into the loose tissue of the integument. Saccate prolongations are then put out from certain of the endosperm-cells, which penetrate into the tissue of the cotyledons, and serve to convey food-materials to the seedling. Both the outermost layer of cells of the cotyledons and the tissue of the endosperm give out a ferment which rapidly corrodes starch. A portion of the endosperm which projects through the micropyle sends out strong haustoria into the calyx-tube. The hypocotyl of this tree has very peculiar stomates, in which the guard-cells are not motile, and the cavity is divided into two chambers.

In *Rhizophora mucronata* the seedlings may attain the height of a metre while still attached to the mother-plant. The upper part of the cotyledons is here provided with a number of papillæ which excrete a starch-destroying enzyme. In *Ægiceras majus* prolongations which have the properties of haustoria are also put out by the endosperm.

**Production of Oxygen and Chlorophyll.\***—Herr Th. W. Engelmann shows, by means of excellent coloured illustrations, the phenomena attending the excretion of oxygen by chromophyllaceous cells under the influence of light. The method of experiment is simple, and consists in watching the aggregation of mobile aerobic bacteria when placed in a drop of water in which is a vegetable cell containing chromophyll of any colour. The illustrations show excellently well how the bacteria crowd around the chromophyll when it is exposed to light.

**Fixation of Free Nitrogen by Algæ.†**—Herr P. Kossowitsch confirms the statement of Frank, Schloesing, and Laurent that certain algæ have the property of fixing the free nitrogen of the atmosphere. It is, however, uncertain whether this is due to the algæ themselves, or to the bacteria which find a favourable nidus in their mucilaginous envelope. With some algæ, e. g. *Cystococcus*, *Stichococcus*, and *Microcoleus vaginatus* (according to Schloesing and Laurent), it is certain that this property is not present. A convenient apparatus for the pure culture of algæ is described.

**Absorption of Water by the Green Parts of Plants.‡**—As the results of a series of experiments performed on a number of different plants, Mr. W. F. Ganong concludes that the absorption of water through the green parts is, in all probability, not a general phenomenon with ordinary land plants, or at all events does not take place to an appreciable amount; though with plants of special habit and special structure, such as the epiphytic Bromeliaceæ, it is quite possible that it does occur.

\* Verhandl. K. Akad. Wetenschappen Amsterdam (Tweede Sectie), Deel iii. No. 11 (1 pl.).

† Bot. Ztg., lii. (1894) 1<sup>te</sup> Abtheil., pp. 97-116 (2 figs.). Cf. this Journal, ante, p. 86.

‡ Bot. Gazette, xix. (1894) pp. 136-43.

**Ascent of Sap.**—Fresh experiments by Prof. S. Schwendener\* confirm his previous statement that the action of suction and of root-pressure does not extend to the middle part of the stem of trees. The movements of sap nevertheless take place without interruption in this portion of the stem, and must be due to forces of a special nature which are not yet fully known, but which play an important part in the life of plants.

Prof. E. Strasburger† replies at great length to Schwendener's criticisms on his previous conclusions, for which he now adduces further evidence, especially insisting on the point that the co-operation of living cells is not necessary for the ascent of sap in plants.

### (3) Irritability.

**Irrito-contractility.**‡—Prof. J. M. Macfarlane has extended the observations already made on *Dionæa* to other sensitive plants, and draws from them the following conclusions:—In the vegetable, as in the animal kingdom, we have to do with a true contractile tissue. In the higher plants this tissue is made up of cells, each consisting of an irrito-contractile protoplasmic sac enclosing a quantity of sap, and each cell joined to neighbouring cells by protoplasmic processes which pass through minute pores in the common cell-wall.

Irrito-contractility may be started by stimuli of a mechanical, chemical, thermal, luminous, or electrical nature. For the movements of the leaves of *Oxalis* and *Mimosa*, called by Darwin paraheliotropic, the author proposes the better term *parathermotropic*, since they are caused not by differences of light, but of temperature. In the case of mechanical stimuli, two successive ones are usually necessary to start contraction.

The phenomena of contractility are described in detail in a number of sensitive plants, species of *Oxalis*, *Mimosa*, *Cassia*, *Amphicarpxæa*, *Desmodium*, &c. The seat of this contractility is unquestionably the vacuolated protoplasm, and not the cell-wall. A similar sensitiveness to impact is possessed also by growing tendrils, notwithstanding the assertion of Pfeffer to the contrary; and the tentacles of *Drosera* are, like tendrils, sensitive to contact as well as to impact. The degree of contraction of an organ is proportional to the relative molecular activity of the protoplasm, and to the strength or continuity of the stimulus.

### (4) Chemical Changes (including Respiration and Fermentation).

**Storing up and Transport of Starch.**§—From observations made in Java, Mr. J. C. Costerus states that, in the case of shrubby plants and those not of great height, where the leaves are exposed to the sun during the whole day, they contain the largest quantity of starch an hour before sunset or earlier; about this time the transport of starch is more energetic than assimilation, while at sunset the latter is altogether suspended, and the slow transfer of starch begins to the places where it is consumed.

\* SB. Akad. Wiss. Berlin, Oct. 26, 1893. See Bot. Centralbl., lvii. (1894) p. 135. Cf. this Journal, 1893, p. 355. † 'Ueber das Saftsteigen,' Jena, 1893, 94 pp.

‡ Biol. Lectures delivered at the Marine Biol. Lab. of Wood's Holl, Mass., 1893 (1894) pp. 185–209. Cf. this Journal, 1883, p. 357.

§ Ann. Jard. Bot. Buitenzorg, xii. (1894) pp. 73–90.

In cloudy weather both processes are weakened, but transmission less so than assimilation.

**Formation and Decomposition of Organic Acids.\***—According to investigations carried on in flowering plants by M. K. Purjewicz, the decomposition of organic acids is always taking place in plants, but is especially favoured by (1) the influence of light, (2) the influence of a high temperature, (3) continuous exposure to darkness at the ordinary temperature. The decomposition under the influence of light takes place also in etiolated organs. It is accompanied by oxidation. The decomposition by a high temperature in the dark appears to be a widely spread phenomenon.

A production of organic acids takes place in all plants in the dark when the temperature is not too high; but is dependent on the previous formation of carbohydrates in the light. The optimum temperature lies between 12° and 15° C. Their formation is the result of an incomplete oxidation of carbohydrates; their destruction depends on a further oxidation with production of carbon dioxide.

The acid formed in the Crassulaceæ is malic, in *Oxalis* and *Pelargonium* oxalic, in *Robinia* tartaric and citric acids. Malic acid is the most easily decomposed by a strong light and high temperature, then oxalic and tartaric acids, while citric acid is the most stable.

**Intramolecular Respiration dependent upon Carbohydrates.†**—M. W. Palladine confirms the observations of Diakonow ‡ (on fungi) that carbon dioxide is disengaged from the living cell into an atmosphere destitute of oxygen; while in the case of etiolated leaves, which contain no carbohydrates, the quantity of carbon dioxide evolved is scarcely perceptible. The introduction of glucose into the tissues increases considerably the amount of carbon dioxide disengaged.

**Influence of Oxygen on Alcoholic Fermentation.§**—From a series of experiments made on pure beer-yeast, M. D. Iwanowskij has come to the conclusion that oxygen has no influence on the energy of fermentation. The diminution in the energy of the process from the access of free oxygen recorded by other observers he believes to be only apparent.

## B. CRYPTOGAMIA.

### Cryptogamia Vascularia.

**Megaspore and Female Prothallium of Selaginella.||**—Herr E. Heinsen has followed out the development of the megaspore and of the female prothallium in various species of *Selaginella*. His results differ in some respects from those of Pfeffer, and establish a closer analogy with the corresponding processes in *Isoetes* and the Coniferæ.

The megaspore is formed endogenously in the protoplasm of the special mother-cell. The protoplasm within the spore is at first homo-

\* 'Die Bildung u. Zersetzung d. organ. Säuren b. d. höheren Pflanzen' (Russian), Kiev, 1893, 90 pp. and 1 pl. See Bot. Centralbl., lviii. (1894) p. 368.

† Rev. Gén. de Bot., vi. (1894) pp. 201-9. Cf. this Journal, ante, p. 371.

‡ Cf. this Journal, 1886, p. 835.

§ Arb. Bot. Lab. Akad. St. Petersburg, 1893, 28 pp. See Bot. Centralbl., lviii. (1894) p. 344.

|| Flora, lxxviii. (1894) pp. 466-96 (1 pl. and 1 fig.).



geneous; as soon as it becomes reticulate, the large nucleus contains a vacuole and two nucleoles. The network of protoplasm subsequently disappears; the whole of the protoplasm becomes applied to the cell-wall, and is denser at the apex of the spore, where several nuclei make their appearance, and the first free-cell-formation takes place. The first septation at the apex of the spore occurs simultaneously with the appearance of protein-granules, and advances gradually towards its base. No diaphragm was observed in any case. The terms primary and secondary prothallium are not applicable to the different zones of the prothallium of *Selaginella*. The extine and intine are formed from a single protoplasmoid shell of the spore; subsequently the intine divides into two layers.

**Stem of *Selaginella*.**\*—Prof. R. J. Harvey Gibson has made a comparative study of the stem of fifty-three species of *Selaginella*; and groups these, according to their anatomical structure, into eight sections, which do not correspond to the divisions of the genus ordinarily adopted and derived from morphological characters. These sections are grouped round the eight species—*S. lævigata*, *spinosa*, *Galeottii*, *Braunii*, *oregana*, *Martensii*, *uncinata*, and *inæqualifolia*.

The author calls attention to the fact that the structure of the ascending is often different from that of the procumbent stem. He retains the term epiderm for the limiting layer of cells, although it is destitute of stomates and has lignified cell-walls; the sclerotized tissue lying immediately below it is the stereome or hypoderm. As endodermal cells he designates the cuticularized cells which arise from the chlorophyllaceous layer surrounding the phloem; the term trabecule is used in a general sense for the unicellular or multicellular strands which anchor the vascular cords to the cortex; a trabecule may be merely an endodermal cell. The term pericycle is retained for the green layer or layers which give origin to the endodermal cells and enclose the phloem; the elements occurring within it constitute the protophloem; for the parenchymatous layer next the xylem he proposes the term phloem-parenchyme. The term vascular bundle is used to indicate a leaf-trace only; stele being retained for the vascular strand enclosed within a pericycle and endoderm.

**Bulbs of *Cystopteris bulbifera*.**†—According to Herr F. Matouschek, the adventitious buds of this species differ in structure from those which occur in other ferns, and present a greater resemblance to the bulbils of Flowering Plants. They consist of fleshy scales which are of a foliar character, and do not develop either fronds or roots while still attached to the parent plant; they germinate only when they have reached the soil, after having been thrown off by the drying up of their basal portion.

**Fossil *Salvinias*.**‡—Mr. A. Hollick finds a number of remains of fossil *Salvinias* in a deposit from Washington Territory, U.S.A., and establishes from them one new species, *S. elliptica*.

**Position of *Sphenophylacæ*.**§—From a fresh examination of the various fossil forms comprised under *Sphenophyllum* and *Trizygia*, Herr

\* Ann. Bot., viii. (1894) pp. 133-206 (4 pls.).

† Oesterr. Bot. Zeitschr., xlv. (1894) pp. 121-4, 177-8 (1 pl.).

‡ Bull. Torrey Bot. Club, xxi. (1894) pp. 253-7 (1 pl.).

§ Ber. Deutsch. Bot. Gesell., xii. (1894) pp. 97-100 (3 figs.).

H. Potonié comes to the conclusion that the stages of development may be represented by the following series:—*Sphenophyllum*, *Trizygia*, *Salvinia*, *Azolla*. This hypothesis is corroborated by the evidence of geology.

#### Muscineæ.

**Anatomy of Mosses.\***—Herr W. Lorch has studied the structure of those mosses which agree with the Sphagnaceæ in possessing, in their leaves, hyaline empty cells with perforated walls, viz. the Leucobryaceæ, and certain genera of Pottiaceæ, *Calymperes*, *Syrrhopodon*, and *Encalypta*.

The leaves of the Leucobryaceæ (*Arthrocnemum*, *Leucobryum*, *Leucophanes*, *Octoblepharum*, *Schistomitrium*, *Spirula*) differ from those of *Sphagnum* in having several layers of cells. In *Leucobryum vulgare* the hyaline cells occupy several layers, the chlorophyllaceous cells only one. The two kinds originate at the same time, the chlorophyllaceous cells attaining ultimately a much larger size than the hyaline. The former are connected with one another by longer or shorter prolongations. They do not divide after being once formed. In the Pottiaceæ with hyaline cells these constitute only a single layer, and this is confined to the basal portion of the leaf. The upper portion of the leaf is composed of chlorophyllaceous cells, mostly isodiametrical and more or less papillose.

The hyaline cells serve for the absorption and storing up of water; the Leucobryaceæ and the genera of Pottiaceæ named growing on rocks, the trunks of trees, and other dry situations. The same service is performed by the papillæ of the chlorophyllaceous cells, and by the hyaline hairs and apices of the leaves in other mosses.

**Venation of the Muscineæ.†**—M. F. Morin has undertaken an exhaustive examination of the venation in different families of Muscineæ; the degree of complication of which he finds in some cases characteristic of species, in others of genera or tribes. There is no general distinction between the venation of the Musci and that of the Hepaticæ. In some cases it is more complicated than that of some aquatic flowering plants.

**Physcomitrium.‡**—Mrs. E. G. Britton gives a monograph of the American species of this genus of Musci, including descriptions of five new species, *P. australe*, *Kellermani*, *Drummondii*, *coloradense*, and *californicum*.

**Rabenhorst's Cryptogamic Flora of Germany (Musci).**—The last two parts published of this portion of Rabenhorst's great work (22 and 23) complete the account of the Meeseaceæ with the monotypic genus *Catoscopium*, and then describe the species of the following families:—Aulacomniaceæ (3 sp. of *Aulacomnium*); Bartramiaceæ (*Plagiopsis* 1 sp., *Conostomum* 1 sp., *Bartramia* 7 sp., *Brentelia* 1 sp., *Philonotis* 11 sp.); Timmiaceæ (4 sp. of *Timmia*); and Polytrichaceæ (*Catharinæa* 5 sp., *Pogonatum* 5 sp., *Polytrichum* 11 sp., *Oligotrichum* 1 sp., *Psilopilum* 1 sp.). The Buxbaumiaceæ are commenced with the genus *Buxbaumia*.

\* Flora, lxxviii. (1894) pp. 424–65 (35 figs.).

† 'Anat. comp. et exp. de la fam. des Muscinées,' Rennes, 1893, 139 pp. and 24 pls. See Bot. Centralbl., lviii. (1894) p. 164.

‡ Bull. Torrey Bot. Club, xxi. (1894) pp. 189–207 (7 pls.).

**Fossil Bryophytes.\***—Sig. U. Brizi describes a number of fossil remains of Muscinæ obtained from the neighbourhood of Rome. Of the twenty-five species described, twenty-three are existing forms, and of these eighteen still occur in the Roman Campagna. The remaining two are new species, belonging to the genera *Rhynchostegium* and *Dicranum*. A single species of Hepaticæ was also found.

#### Algæ.

**Formation and Erosion of Rocks by Algæ.†**—Prof. F. Cohn points out the important part played by very lowly organized Algæ—Phycocromaceæ and Cyanophyceæ—in the formation of calcareous and siliceous rocks. Many beds of marble and travertin have been formed in this way. He further enumerates the algæ that are known to destroy calcareous rocks by erosion. In all fixed algæ there appears to be this contrast between the basal cells and the rest of the filament; that the former excrete an acid which dissolves lime; while the latter has the power of depositing a soluble lime-salt between the filaments, but within the mucilage which is excreted from the sheath.

**Classification of the Lower Green Algæ.‡**—Prof. R. Chodat and Dr. J. Huber place at the base of algæ the genera *Palmella* and *Tetraspora*, characterized by the palmelloid mode of division, i. e. in one plane only, no firm membrane being formed round the new protoplasts, which are separated from one another only by a mucilaginous lamella. Each cell thus formed may become transformed into a biciliated zoospore (megazoospore).

From the Palmellaceæ are probably derived directly the Volvocineæ, in which the motile phase preponderates; the simplest form, *Chlamydomonas*, may be regarded as a megazoospore furnished with a membrane. Nearly allied to the Volvocineæ are the Pediastreæ, *Pediastrum* being comparable to a *Pandorina* in which the gelatinous mass has solidified round the products of division.

Another group is constituted of the Pleurococcoideæ,—unicellular algæ in which the preponderating mode of multiplication is the sporangial, i. e. one in which each new protoplast is surrounded by a firm membrane. These develop further in several series. In the Characiaceæ the cell is isolated and fixed, and produces two kinds of zoospore which germinate at a distance from the parent plant. In *Sciadium* the zoospores are arranged in a rosette at the apex of the capsule. *Ophiocytium*, *Raphidium*, *Actidesmium*, *Mischococcus*, *Oocardium*, and *Dactylococcus* are nearly related.

A good example of the distinction between the palmelloid and the protococcoid mode of division is afforded by *Tetraspora* on the one hand and *Monostroma* on the other hand. From the latter genus are derived the Ulvaceæ. At the base of the Pleurococcoideæ, which have hitherto been united under the name of Confervoideæ, are the Chlorosphæraceæ, in which are two modes of multiplication, a vegetative septation and a sporangial division. This latter mode of division gives rise to the

\* Bull. Soc. Bot. Ital., 1893, pp. 369-73.

† JB. Schles. Ges. Vaterl. Cultur, 1892 (1893) 2<sup>te</sup> Abtheil., pp. 77-9; and 1893 (1894) pp. 19-22.

‡ Arch. Sci. Phys. et Nat., xxxi. (1894) pp. 395-401.

Chætophoraceæ, at the base of which are placed *Stigeoclonium*, *Ctenocladus*, *Chættonema*, and *Endoclonium*.

**New Genera and Species of Algæ.\***—Prof. J. G. Agardh gives a monograph of the Dictyotaceæ, which he divides into the following forms:—Zonariaceæ (*Gymnosorus* g. n., *Zonaria*, *Homœostrichus* g. n., *Chladinophora* g. n.); Padineæ (*Microzonia* g. n., *Styppodium*, *Lobophora* g. n., *Taonia*, *Padina*); Spatoglosseæ (*Spatoglossum*, *Stechospermum*, *Halyseri*); and Dictyotææ (*Dictyota*, *Pachydictyon* g. n., *Dilophus*, *Lobospira*). The new genera are for the most part formed by the subdivision of older genera; 35 species of *Dictyota* are described, arranged in four sub-genera. In *Taonia* and *Padina* organs resembling zoosporanges were observed.

Among Siphoneæ several new species are described, and the following new genus, *Bracebridgia*:—Frons cylindracea vage decomposita-ramosa, ramis extimis conspicue attenuatis, elementis quasi heterogeneis composita; axili nempe regione siphonibus cylindraceis oblongis superpositis, seriem unicam centram formantibus constituta; intermedio strato axiles siphones circumcirca densissime obtigentes, filis confervoideis longius articulatis secus longitudinem excurrentibus, calcarea substantia invicem et cum siphonibus axilibus coalitis, contexto; exteriori denique composito filis magis verticicalibus exeuntibus, brevibus articulatis, parce dichotomis, ramis invicem liberis; articulis filorum interioribus cylindraceis, terminalibus obovatis.

Among Phæosporeæ we have a new genus of Ectocarpaceæ, *Xanthosiphonia*, with the following diagnosis,—Frons filiformis, ex flavescente virescens, quoquoersum ramosa, articulata, polysiphonea, articulis nempe cylindraceis, in cellulas plures in orbem dispositas æque longas sensim abeuntibus contexta, ramulis junioribus et supremis monosiphoneis; siliquæ ex lanceoideo subulatæ longissimæ, articulis brevissimis plurimis; diametro siliquæ 2-4 plo brevioribus, in partes longitudinales plurimas in orbem dispositas segmentatis.

Several new species of Florideæ are described, with the following new genus, *Dasythamnon*: Frons teretiusecula, pinnatim subdistiche ramosa, filis funiculariter coalescentibus, stupam axilem spongiosam formantibus, ramentisque extra stupam liberis elongatis, tomentum externum constituentibus composita, quasi heterogenea; stupa nimirum a filo primario axili articulato monosiphoneo, minoribusque cingentibus composita, ramentis liberis a filis extimis secus stupam excurrentibus generatis; favellæ in ramulis subdistichis provenientibus, coma ramentorum incurvatorum obtectæ, et quasi in eodem nido plures juxtapositæ, intra periderma hyalinum gemmidiorum fasciculos numerosos foventes; fasciculi singuli quasi filis dichotomis extrorsum fastigiatis, a centrali regione provenientibus, circumcirca extrorsum radiantibus constituti.

**Schizymenia.†**—Prof. F. Schmitz enters into a very detailed discussion of the very complicated synonymy of the species of this genus of Florideæ. He recognizes only two species in the Flora of the Mediterranean, *S. marginata* and *Dubuyi*.

\* Act. Univ. Lund., xxix. (1893) 144 pp. and 2 pls. Cf. this Journal, ante, p. 483.

† La Nuova Notarisa, v. (1894) pp. 608-35.



**Systematic Position of the Bangiaceæ.\***—Prof. T. Johnson adduces arguments in contravention of Schmitz's proposal to separate the Bangiaceæ (*Bangia*, *Porphyra*, *Wildemania*, *Erythrotrichia*, *Goniotrichum*) altogether from the Florideæ. He would retain them as the lowest family in this class, grouping all the other families under the sub-class EU-FLORIDEÆ.

The Bangiaceæ agree with the Eu-Florideæ in the colour of the chromatophores; in the reproduction both by non-sexual spores and by sexual organs; in the male organs being "spermatia" (pollinoids); and in the mode of impregnation. The differences consist mainly in the form of the thallus; in the continuity of the cell-contents in the Bangiaceæ by fine strands of protoplasm passing through the cell-walls; in the non-sexual spores being usually tetraspores in the Eu-Florideæ, monospores, bispores, or tetraspores in the Bangiaceæ; in the position of the "spermatanges" (antherids); in the position of the carpogones, and the rudimentary condition of the trichogyne in the Bangiaceæ; and in the arrangement of the carpospores. This latter point the author believes to be dependent on the nutrition, on facility of formation, and on the mode of distribution of the spores.

**Irritability of Spermatozoids of Fucaceæ.†**—Dr. J. Bordet has studied the irritability of these bodies, and finds that, in normal conditions, they are not affected by numerous reagents; thus, they neither seek nor avoid light, are not attracted to the egg-cell by the influence of chemical substances; they are affected only by contact, and to this they are very sensitive. The various Algæ—*Fucus platycarpus*, *F. vesiculosus*, *Himantalia lorea*, and *Ascophyllum nodosum*—which have been studied often, grow side by side in great quantities; as the products of the reproductive cells generally escape at low tides, they are not, as a rule, carried far. Small quantities of water flow slowly from one plant to another, and are sufficiently charged with male and female products to make a meeting inevitable. Moreover the number of reproductive elements is so considerable that many may be lost without the species running any risk of being discontinued.

**Bulbils of Chætonema.‡**—Dr. J. Huber has observed, on *Chætonema irregulare*, the formation of propagative organs of the nature of bulbils, on the same filaments as those which produce zoospores.

**Development of Pedicellum.§**—Prof. R. Chodat and Dr. J. Huber confirm the observation of Braun as to the mode of multiplication of *Pedicellum* by the formation of gelatinous vesicles in which new individuals are formed by successive bipartitions. The formation of these gelatinous vesicles they found to be dependent on the nature of the medium. The vesicle is formed from a cellular coating intermediate between the true cell-wall of each cell and the protoplasm which it encloses. *Pedicellum* occupies a position intermediate between the Scenedesmeæ and the Hydrodictyæ.

\* La Nuova Notarisia, v. (1894) pp. 636-47. Cf. this Journal, 1893, p. 763.

† Bull. Acad. Roy. Belg., lxiv. (1894) pp. 888-96.

‡ Bull. Herb. Boissier, 1894, p. 163 (1 pl.). See Hedwigia, xxxiii. (1894) Rep., p. 78.

§ Ann. Sci. Phys. et Nat., xxxi. (1894) pp. 386-7.

De Toni's *Sylloge Algarum*.—The third section of volume ii. of this most useful publication is entirely devoted to the Cryptophyceæ, an order of Diatoms, which are divided into thirteen families, the Rhizosolenaceæ, Isthmiaceæ, Hemiaulidaceæ, Biddulphiaceæ, Chætoceraceæ, Thaumatomonadaceæ, Rutilariaceæ, Eupodiscaceæ, Xanthiopyxidaceæ, Coscinodiscaceæ, Melosiraceæ, Heliopeltaceæ, and Asterolampraceæ. Among the larger genera are *Triceratium*, 325 sp., *Aulacodiscus* 102, *Coscinodiscus* 302, *Actinopterychus* 111. A "Repertorium Geographico-polyglottum in usum Sylloges Algarum omnium" is appended, and an Index to the genera and species of Diatoms.

**Fucoides.\***—Mr. J. F. James enumerates all the very numerous organisms that have been described as species of this genus of Fossil Algæ. He proposes to limit the genus to Brongniart's original species *F. serratus*. The remaining five species described by Brongniart he places in a distinct genus *Gigartinites* (sub-genus Brongn.). Of the remaining structures which have been described as species of *Fucoides*, many are now referred to totally different genera of Algæ, and others to Vascular Cryptogams, while a few are inorganic.

#### Fungi.

**Pigments of Fungi.†**—Pursuing his investigations into the nature of the pigments of the lower plants and animals, Prof. W. Zopf finds substances of the nature of carotin very commonly present in the Hypocreaceæ; not unfrequently two different carotins, a red and a yellow one, occur together. The red carotin of *Polystigma rubrum* and *Nectria cinnabarina* are called respectively "polystigmin," and "nectriin." In *Ditiola radicata* (Tremellineæ), a yellow carotin was found. *Polyporus sanguineus* contains three distinct pigments; while in *Cortinarius cinnabarinus* no less than four were detected. From *C. cinnamomeus* an acid was separated which is termed by Zopf "cortinaric acid."

**Erysiphea-like Fructification in the Saprolegniaceæ.‡**—Prof. W. Zopf describes a new species of *Dictyuchus*, which he names *D. carpophorus*, which forms an oosporange-fructification enclosed on all sides, in which he traces a resemblance to the ascus of *Podosphæra*. In this species zoosporanges are produced on the same individual.

**Sporanges of *Thamnidium elegans*.§**—Herr J. Bachmann finds numerous transitional stages between the extreme forms which are known to exist in the sporanges of *Thamnidium elegans*, viz. a single large terminal sporange, with a distinct columel, numerous spores, and a membrane capable of swelling, and sporangioles with but few spores, no columel, and a membrane not capable of swelling, borne on dichotomous branches. The formation of the different kinds of sporange is entirely dependent on the nature of the nutriment. The author distinguishes the following six types:—(1) Sporanges terminal; the dichotomous branches greatly divided; the sporangioles appear early and have fewer

\* Journ. Cincinnati Soc. Nat. Hist., xvi. (1893) pp. 62-81 (3 pls.).

† Beitr. z. Phys. u. Morph. niederer Organismen (Zopf), Heft 3 (1893) pp. 26-47, 60-74 (4 figs). Cf. this Journal, 1893, p. 496.

‡ Beitr. z. Phys. u. Morph. niederer Organismen (Zopf), Heft 3 (1893) pp. 48-59 (2 pls.).

§ Ber. Deutsch. Bot. Gesell., xii. (1894) pp. 93-6.

than eight spores, usually one to four; (2) Sporangies terminal; sporangioles 16–20  $\mu$  with more than eight spores, usually with a columel and partial swelling of the membrane; (3) Terminal sporangies only; (4) Sporangioles only; (5) Mycelle without either sporangies or sporangioles; (6) Mycelle with zygospores.

**Classification of the Pyrenomyces.\***—M. A. de Jaczewski proposes the classification of the genera belonging to this vast order of Fungi under nineteen families. The Hysteriaceæ are included; while the Sordariaceæ and Hypocreaceæ are suppressed as distinct families. The author adopts Brefeld's classification of the Ascomycetes, dividing them first into the Exoasci and Carpoasci, and the latter again into the Angiocarpæ (Gymnoasci, Pyrenomyces) and Hemiangiocarpæ (Discomycetes).

**Parasitic Fungi.**—M. L. Trabut † describes a disease of the beet caused by a fungus belonging to the Ustilaginæ, *Entyloma leproideum* sp. n.

A new disease of the vine which has recently appeared in France is attributed by M. L. Ravaz ‡ to *Botrytis cinerea*.

Herr P. Magnus § finds a new species of *Phragmidium*, which he names *P. circumvallatum*, parasitic on *Geum heterocarpum* in Kurdistan, probably belonging to the same cycle of development as *Cœoma circumvallatum*. He describes also a number of other parasitic fungi from Eastern Europe, and corrects previous observations with regard to the teleutospores of *Puccinia Smyrni*.

According to Mr. N. B. Pierce, || *Cercospora circumscissa* is very destructive to almond trees in Southern California.

Under the name *Wallenia ichthyophaga* sp. n., Herr J. Istvanfi ¶ describes a parasitic fungus very destructive to the codfish in Norway.

A disease of barley, which makes its appearance as brown spots on the stalk and leaves, is attributed by Dr. K. Bruhne \*\* to a hitherto undescribed parasitic fungus, *Hormodendron Hordei*, belonging to the Ascomycetes. It produces several enzymes, but not a diastatic ferment.

Mr. F. M. Webster †† describes the destructive effects of several species of *Empusa*, including *E. sphaerosperma*, *pachyrhinæ*, and *aulicæ*, on the larvæ of insects in America.

Prof. G. F. Atkinson †† has successfully cultivated *Isaria farinosa*, an entomogenous fungus, on potato.

**Injuries produced by Gymnosporangium.** §§ — Herr P. Wörnle describes in detail the injuries inflicted on the host by the various species

\* Bull. Soc. Mycol. France, 1894, 13 pp. See Hedwigia, xxxiii. (1894) Rep. p. 52.

† Comptes Rendus, cxviii. (1894) pp. 1288–9. ‡ Tom. cit., pp. 1289–90.

§ Ber. Deutsch. Bot. Gesell., xii. (1894) pp. 84–8 (1 pl.).

|| Journ. of Mycol., vii. (1892) p. 66 (1 pl.). See Hedwigia, xxxiii. (1894) Rep., p. 25.

¶ SB. K. Ung. Naturw. Gesell. Buda-Pest, Dec. 13, 1893. See Bot. Centralbl., lviii. (1894) p. 197.

\*\* Beitr. z. Phys. u. Morph. niederer Organismen (Zopf), Heft 4 (1894) pp. 1–42 (1 pl.).

†† Journ. Cincinnati Soc. Nat. Hist., xvi. (1894) pp. 173–7.

‡‡ Bot. Gazette, xix. (1894) pp. 129–35 (3 pls.).

§§ Forstl. Naturw. Zeitschr., 1894, pp. 68 and 129 (1 fig.). See Hedwigia, xxxiii. (1894) Rep., p. 84.

of *Gymnosporangium*, especially *G. juniperinum*, *clavariæforme*, and *Sabinae*. They all cause a hypertrophy of the parenchyme, but the exact changes produced are characteristic of each species.

**Sclerote of Rhododendron.**\*—Herr E. Fischer finds the fruit of the Alpine species of *Rhododendron* to be infected by a sclerote (*Sclerotinia Rhododendri*) very similar to that of *Vaccinium*. By cultivation he was able to obtain the ascus-fruit. Besides ascospores, it forms also chlamydospores; but no conidia have at present been detected. It is not identical with the fungus parasitic on *R. dahuricum*.

**Microbiology and Manufacture of Arrack.**†—The botanical position of *Amylomyces Rouxii*, described by Calmette ‡ as the principal organism in Chinese yeast used for making arrack, has been determined by Dr. C. Eijkmann, who finds that it is a species of *Mucor*, and suggests that it be called *M. amylomyces Rouxii*. The fungus consists of a mycelium from which proceed sporangiophores topped with *Mucor* heads. The sporangia are filled with blackish spheroidal spores. The columella is large and rounded. The fertile hyphae are much branched, and send rhizoids downwards. Zygospermeformation was not observed. Besides this there appears to be an asporogenous variety which, while it possesses a strong diastatic action, has little tendency to decompose the sugar so formed into lactic acid.

Though at first sight it might seem certain that this organism plays the principal part in the fermentation of the molasses used in the production of arrack, yet, according to the author, the effective agent is a fungus 0.005–0.006 mm. thick and 0.02–0.04 mm. long. It multiplies by fission, and is a very powerful alcoholic ferment. Its wall is of cellulose, and its contents finely granular. It has two characteristic shapes, one cylindrical with rounded ends, the other resembling a flail. It grows well on saccharine or amylaceous media. Spore-formation was not observed. It inverts cane sugar, forming alcohol and carbonic acid in pretty considerable quantity, and when a pure cultivation is sown on molasses, the fluid has all the character of good arrack.

**Schizosaccharomyces octosporus.**§—M. M. W. Beyerinck describes an alcohol yeast which was isolated from currants from Zante. Numerous examples of the organism are clearly depicted in the illustrations drawn by the author; these show that the organism varies in shape with different cultivation media; for on wort-gelatin it is oval, single or in pairs, some pairs being united by a narrow band, while others are capped. In glucose wort they are round, in pairs, tetrads or octads. On acid lævulose-wort the shape is irregular. The average size of these young cells is about 8  $\mu$ , while the asci are from 12–20  $\mu$ . The asci always contain eight spores, which when ripe are spheres about  $4\frac{1}{2}$   $\mu$  in diameter. They possess a nucleus, and their plasma presents a radiated appearance.

Only on media containing glucose, lævulose, and maltose does this organism thrive with fermentation and production of alcohol; on cane

\* Ber. Schweiz. Bot. Gesell., 1894, Heft 4. See Bot. Centralbl., lviii. (1894) p. 138.

† Centralbl. f. Bakteriologie u. Parasitenk., xvi. (1894) pp. 97–103 (3 figs.).

‡ Cf. this Journal, 1893, p. 681.

§ Centralbl. f. Bakteriologie u. Parasitenk., xvi. (1894) pp. 49–58 (1 pl.).



sugar and others it develops badly or not at all. The best medium was acidulated malt-wort to which 3-5 per cent. of glucose or lævulose had been added. On this there was lively fermentation with production of a peculiar odour and taste. The alcohol distilled off was ordinary ethyl-alcohol. The fermentation time is about twelve times as long as that of ordinary beer or wine yeast, and the amount of alcohol small, being not more than 0.7 per cent.

*Lactomyces inflans caseigrana*.\*—Dr. N. Bochicchio has discovered a yeast in Lombardy cheese which is called from its general characters *Lactomyces inflans caseigrana*. This organism decomposes various sugars, especially lactose, develops large quantities of gas, and hence is able to make cheese disagreeably spongy. It develops with the greatest ease on any media, and lives even in sterilized water or on gypsum blocks. On gelatin the colonies are white, smooth, circular, often some millimetres in diameter; the gelatin is not liquefied.

The individual cells are oval, elliptical, spheroidal, or rod-like,  $5\ \mu$  long and  $3\ \mu$  broad, their investing membrane is easily seen, and occasionally a nucleus and vacuoles. They are easily stained, and are not decolorized by Gram's method. On saccharated media, with free access of air and at  $20^{\circ}$ - $30^{\circ}$  or even  $40^{\circ}$ , the organism attains its highest development, while the odour of fermenting must is clearly perceptible. Milk is slowly coagulated, and the coagulum in its turn partially liquefied. If inoculated in fresh healthy milk from which a hard cheese is made, the cheese soon becomes spongy from the presence of large holes, especially in its surface portions. Whey is converted into a frothy fluid with a not disagreeable taste.

History of Development of the Uredineæ.†—Herr J. Schröter proposes the term "species sorores" for any two species of Uredineæ which are regarded as distinct simply because, in a certain stage, they inhabit different host-plants, but which exhibit no clear morphological difference. In this way *Puccinia coronata* consists of at least two "species sorores," as also does *P. Phragmitis*, one of its "species sorores" inhabiting, in its æcidio-form, the large-leaved species of *Rumex*, the other (*P. Treylii*) growing on *Rumex acetosa*. Similar phenomena recur in species of *Coleosporium*.

Alternation of Generations in the Uredineæ.‡—Herr P. Dietel brings forward several instances in which the ordinary alternation of generations in the Uredineæ is suspended, one æcidio-generation being produced directly from another. This occurs in *Puccinia Senecionis*, *Uromyces Ervi*, and probably in other species also.

Teleutospores of Uredineæ.§—Herr P. Dietel describes the process of the swelling of the pedicel of the teleutospores in many Uredineæ which facilitates the detachment of the spores. The details of the process vary in a variety of ways, and are especially described in the

\* Centralbl. f. Bakteriöl. u. Parasitenk., xv. (1894) pp. 546-52 (3 figs.); and Ann. de Micrographie, vi. (1894) pp. 165-77 (3 figs.).

† JB. Schles. Ges. Vaterl. Cultur, 1893 (1894) 2<sup>o</sup> Abtheil., pp. 31-2.

‡ Zeitschr. f. Pflanzenkrankheiten, iii. (1893) pp. 258-66. See Bot. Centralbl., lvii. (1894) p. 44.

§ Jahrb. f. wiss. Bot. (Pringsheim), xxvii. (1894) pp. 49-81 (1 pl.).

eases of *Phragmidium Rubi-Idæi*, *Uropyxis Steudneri*, *Diorchidium*, *Ravenelia*, and *Gymnosporangium*.

**Fungus Flux of Trees.\***—Prof. F. Ludwig has examined the ruby-red transparent gummy substance exuded from the bark of the hornbeam, and finds that it consists almost entirely of curved, highly-refracting bodies which, from the lively movements they display when a solution of the gummy mass is made, and from the facility with which they pick up anilin dyes, are easily mistaken for bacteria. They are, however, the microconids (spermatia, *Pycnospora*) of a Hyphomycete, which is the direct cause of the gummy flux, and owing to the presence of which the tree becomes diseased.

A very similar condition is found to exist in the sweet chestnut; for this tree suffers from a disease which appears to be associated with microconids similar to those found in the hornbeam. In the chestnut the wood undergoes a peculiar maceration, which makes it look as if it had been worm-eaten, and this is apparently due to the penetration of the tissue and vessels by a mycele which, after transformation into a gummy fluid, and the evacuation of the latter leaves the tree in this condition. Thus the course of events appears to be the formation of pycnids which send mycelial extensions into the tissues, and from this the gummy fluid and microconids are produced.

**Actinomycetes.†**—Sig. G. Gasparini takes account of no less than eighteen species of this genus, and describes those which have been adequately determined. Apart from the systematic part of the paper, the author states his general conclusions as to the life-history, variations, and pathological effects of these important parasites. Only a few samples can be quoted. The normal reproduction is by means of free aerial spores (conids); and when, through deficiency of oxygen or some other cause, the production of aerial filaments is prevented, toruloid aggregations in the mycele acquire the value of spores. The bovine actinomycosis may be produced by diverse varieties. Isolated forms become in culture more greedy of oxygen, and may lose their power of developing anaerobically and their virulence. Their occurrence is quite independent of the diet of their host. From the air, the water, the soil, &c., the spores find their way to some solution of continuity on the skin or mucous membrane of the animal.

**Fungi of Favus.**—Herr Biro ‡ describes culture-experiments with the favus-fungus on bouillon, potato, meat-pepton-gelatin, and meat-pepton-agar; also microscopical examination of Elsenberg's two varieties. The fungus consists of a mycele composed of filaments with outrunners; the hyphæ produce spores, and often branch dichotomously. The best staining-reagents he found to be eosin and hæmatoxylin. The three species, *Achorion cutylirix*, *A. atacton*, and Biro's fungus, gave identical results. The parasite enters the hair-sac, finds its way between this and the surrounding peripheral portion, raises up the epiderm, and is seen through the raised epidermal layer as a yellow dot. There appears to be no ground for the conclusion that there are several favus-fungi.

\* Centrabl. f. Bakteriolog. u. Parasitenk., xvi. (1894) pp. 58-61. Cf. this Journal, 1892, p. 83.

† Atti Soc. Tosc. Sci. Nat., ix. (1894) pp. 64-89.

‡ Arch. f. Dermat. u. Syphilis, 1893, Heft 4. See Centrabl. f. Bakteriolog. u. Parasitenk., xv. (1894) p. 69.

Herr Jessner, \* on the other hand, while identifying *A. atacton* and *eutythrix*, regards *A. dikroon* and *Schænleinii* as distinct species. It is possible, however, that the different species may have the same origin, and may be the final products of a metamorphosis, the result of the influence of varying vital conditions.

M. J. Costantini † has established, by culture experiments, the specific distinctness of the favus of the fowl, *Epidermophyton Gallinæ*, from that of man, *Achorion Schænleinii*. The spores of the former are chlamydo-spores, analogous to those of *Hypomyces*.

Fossil Fungi.—M. R. Ferry ‡ gives an account of the appearance of Fungi in geological formations, beginning with the Carboniferous, and a list of the species hitherto described, distributed among forty-one genera. To these Mr. J. F. James makes some additions.

Mr. R. Herzer § has found, in the Coal-measures of Ohio, a fossil fungus which he makes the type of a new genus, and describes as *Dactyloporus archæus* g. et sp. n. It appears to be intermediate between *Agaricus* and *Polyporus*.

### Protophyta.

#### a. Schizophyceæ.

Snow-flora of Spitzbergen. ¶—Prof. G. v. Lagerheim enumerates and describes the forms of vegetable life found in a gathering from Spitzbergen. They consist of one species each of the genera *Bichatia*, *Aphanocapsa* (*A. nivalis* sp. n.), *Phormidium*, and *Pleurococcus*, two species of *Hormiscia*, and an unidentified diatom.

Development of *Dictyosphærium*. ¶—Prof. W. Zopf has traced out the development of a colony of *Dictyosphærium*. The gonids, as soon as they become detached, become sporanges, their contents dividing into two, three, or four daughter-gonids. The sporange bursts at the apex into a star-shaped structure, each arm having a gonid attached to its extremity. This process is repeated several times, and the branched colony formed, the bands into which the wall of the sporange splits acquiring more and more the form of threads.

The author believes *Dictyosphærium* to be nearly allied to *Sciadium*, and possibly also to *Cosmocladium*, *Oocardium*, and *Actidesmium*. He groups these genera under a new family, which he names SCIADIACEÆ, characterized by a differentiation of base and apex; the colony is either permanently attached by the base or ultimately free-swimming.

Development of *Raphidium*. \*\*—According to Prof. R. Chodat, *Raphidium* has a fixed condition in which it strongly resembles a *Characium*. In this state the products of division of the mother-cell escape from its apex in a manner similar to the zoospores of *Sciadium*. They become

\* Berl. Klin. Wochenschr., 1893. See Centralbl. f. Bakteriolog. u. Parasitenk., xv. (1894) p. 71.

† Bull. Soc. Mycol. France, 1893, p. 166. See Bot. Centralbl., 1894, Beih., p. 62.

‡ Rev. Mycol., 1893, pp. 54-6. See J. F. James in Journ. Cincinnati Soc. Nat. Hist., xvi. (1893) pp. 94-100.

§ Amer. Geol., xii. pp. 219-90 (1 pl.). See Bull. Torrey Bot. Club, xx. (1893) p. 494.

¶ La Nuova Notarisia, v. (1894) pp. 650-4 (1 fig.).

\*\* Beitr. z. Phys. u. Morph. niederer Organismen (Zopf), Heft 3 (1893) pp. 15-25 (1 pl. and 1 fig.).

\*\* Ann. Sci. Phys. et Nat., xxxi. (1894) pp. 387-8.



fixed in the same way to the apex of the mother-cell in an arborescent manner. The three genera *Sciadium*, *Characium*, and *Raphidium* are, therefore, nearly related to one another, and differ essentially from *Pleurococcus* in the absence of a true septation.

**Re-establishment of the Size of Diatoms.\***—Dr. P. Miquel proposes to abolish the terms sporangial frustule and auxospore, as used in the description of diatoms; and to apply the term “mother-valve” to the valve which a diatom retains during the whole of its existence, “daughter-valve” to that which a portion of the protoplasm carries with it in the formation of a new individual. The author gives the following account of the re-establishment of the original size and the restoration of the form, derived from the observation, under cultivation, of a vast number of individuals belonging to a variety of species of the genera *Melosira*, *Cyclotella*, *Biddulphia*, *Nitzschia*, and *Navicula*.

The protoplasm contained in the microfrustule clothes itself with a thick extensible membrane capable of resisting the strongest mineral acids; it appears to be composed of cellulose and hydrate of silica, and is formed before the protoplasm frees itself from the valves which imprison it in the microfrustule. The valves then separate, and are thrown off by the protoplasm; the membrane which encloses the new cell is soft and flexible. The growth of the protoplasm takes place mainly, though not entirely, at right angles to the axis which joins the future nuclei, and continues until it has regained the size which it had lost by reduplication. As soon as it has attained this size, its external membrane secretes a siliceous envelope, which, however, is absent from the plane perpendicular to the axis of the nuclei. It is in this plane that the protoplasm divides to form two interior valves, the two first daughter-valves; and these two halves of the original megafrustule produce, by reduplication, new generations of diatoms to the number of 2<sup>n</sup>.

The nucleus is the main agent in the regeneration of the size of diatoms. After the contents of the microfrustule have condensed and surrounded themselves with a firm membrane, this “spore” germinates, and produces an individual which is the diatom with its original size restored, and presenting, on its siliceous walls, the markings characteristic of the species.

Without denying the possibility of its occurrence, the author has never observed, in any diatom, a process analogous to conjugation; nor the breaking up of the contents of the siliceous frustules into a number of microspores.

**Movements of Diatoms.**—Replying to the observations of Müller on this subject, Herr R. Lauterborn † repeats his statement that the frustules of *Pinnularia major*, *nobilis*, and *viridis* are surrounded by a distinct mucilaginous envelope, though this has not yet been detected in other genera, nor in *P. oblonga*. The strings of protoplasm projecting through the raphe, to which Müller ascribes the power of movement, are,

\* Ann. de Micrographie, v. (1893) pp. 521-47 (8 figs.); Le Diatomiste, ii. (1894) pp. 61-71, 88-98 (8 figs.).

† Ber. Deutsch. Bot. Gesell., xii. (1894) pp. 73-8 (1 fig.). Cf. this Journal, ante, p. 382.



according to Lauterborn, purely hypothetical. The production of motility by streaming protoplasm would be an isolated phenomenon either in the vegetable or the animal kingdom; while movements caused by the excretion of mucilage occur also in the Desmidiæ and Oscillatorieæ; and, according to Schewiakoff, also in the creeping Gregarinidæ.

Herr O. Müller \* replies to the objections of Lauterborn to his hypothesis that the movements of diatoms are effected by means of a protoplasmic thread extruded from the raphe, and adduces fresh arguments in its favour derived from the observation of the same three species of *Pinnularia*. The viscid substance of this thread he states to be distinct from the non-viscid substance of the mucilaginous layer, and identical with the layer which flows in the immediate proximity of the raphe. The analogy sought to be drawn between the nature of the movements of diatoms and of desmids is a deceptive one. It is true that the protoplasm, in its escape, excretes mucilage also; but this hinders, rather than promotes, the movement of the diatom.

#### β. Schizomycetes.

**Effect of Sunlight on the Human Organism and on Micro-organisms.**†—Dr. H. Schickhardt finds that sunlight exerts an unfavourable influence on most micro-organisms, either by interfering with their development or by completely destroying them. The time required for destroying them varies according to the nature of the individual bacteria and their pabulum, and depends on the intensity of the light and the length of its action. The effective agent appears to lie in the chemical rays (violet and ultra-violet). While light has a direct bactericidal action, it also exerts some influence on the nutrient medium; at any rate this is demonstrable when the bacillus of typhoid is grown on gelatin. On mould-fungi sunlight has no influence.

**Action of Nuclein Acid on Bacteria.**‡—Dr. H. Kossel finds that nuclein acid which was obtained from lymph cells of the calf possesses powerful bactericidal properties. A 0·5 per cent. solution kills cholera vibrios in 3–5 minutes, typhoid bacilli in 1–1½ hours, streptococci in about 2 hours, staphylococci in 6 hours, while anthrax spores take 24 hours. The author assumes that the bactericidal power is the result of the precipitation of albumen by the acid.

**Formation of Sulphuretted Hydrogen and Mercaptan by Aerobic Bacteria.**§—Drs. R. J. Petri and A. Maassen find that anthrax, Tetragenus, diphtheria, hay bacillus, root bacillus, and potato bacillus do produce  $H_2S$ , and that the formation of this gas is influenced by the presence of various agents or is even concealed by them. Thus with all bacteria the  $H_2S$  production, even in the presence of free sulphur, is

\* Tom. cit., pp. 136–43 (1 fig.).

† Friedreich's Blätter f. Gerichtliche Medizin u. Sanitäts-polizei, xliv. (1893) pp. 350–92, 400–38. See Centralbl. f. Bakteriol. u. Parasitenk., xv. (1894) p. 1020.

‡ SB. Phys. Gesellsch. zu Berlin, Dec. 8, 1893. See Centralbl. f. Bakteriol. u. Parasitenk., xv. (1894) p. 1018.

§ Arb. a. d. Kaiserl. Gesundheitsamte, ix. (1893) pp. 490–506. See Centralbl. f. Bakteriol. u. Parasitenk., xv. (1894) pp. 908–9.

diminished on the addition of saltpetre, which is reduced more or less to nitrite or ammonia.

When cultivated on eggs *B. ramosus* and *B. cholerae asiaticæ* produce  $H_2S$  copiously, and on blood serum when solid. Reaction for  $H_2S$  was only obtained when the medium was liquefied. Besides  $H_2S$  bacteria produce mercaptan, especially in solutions containing 10 per cent. pepton, and in egg and serum cultures. Both  $H_2S$  and mercaptan are formed in the presence of nascent hydrogen from Witte's pepton. From experiments on animals, undiluted ethyl-mercaptan appears to be highly poisonous. The authors then proceed to discuss the theory of  $H_2S$  formation by bacteria.

**Influence of Alcohol, Glycerin, and Olive Oil on Disinfectants.\***—Dr. P. Lenti finds that alcohol in the absence of water annuls the bactericidal power of sublimate or carbolic acid for anthrax spores, even when the sublimate is in 4 per thousand and the phenol in 10 per cent. solution. The bactericidal power is recovered sufficiently to destroy spores only when the alcohol is diluted with not less than 2 per cent. of water for solutions of 1 per thousand sublimate, and of 70 per cent. for the solutions of carbolic acid, the length of time required by the sublimate being 24 hours, and 48 hours for the carbolic acid.

Glycerin acts in quite a similar way; for it impedes the action of 2 per thousand solutions of sublimate when there is less than 40 per cent. of water. The inhibitory action is even more marked with carbolic acid, for spores are completely destroyed only after 72 hours in 10 per cent. carbolic acid with at least 80 per cent. of water. When carbolic acid and lysol are present in olive oil they have no disinfecting action.

**Bacteriology in Surgery.†**—Dr. Wertheim states that Dr. Schanta has a competent bacteriologist present during operations on appendages; the pus can be examined for bacilli within three minutes. So long as any cocci except gonococci are present drainage is always employed, as these septic cocci imply connection with the intestines or other cavities often too minute to be detected.

**Bacterial Flora of the Atlantic Ocean.‡**—Mr. H. L. Russell finds, from examinations of ocean water in the vicinity of Woods Holl, Mass., that bacteria, while present both in the deep seas and in littoral regions, are less abundant than in fresh water. In the mud of the ocean bottom, where they exist in large numbers, their presence is due both to the effect of gravity and to growth and reproduction of indigenous slime species. The number of bacteria varied from a few germs to 120 per ccm., the deeper strata being just as rich in bacteria as the superficial. Nearly a hundred samples of the sea bottom showed that the average number of bacteria per ccm. was about 17,000. The great difference between the number of bacteria found in the sea bottom and in the water immediately above is rather to be ascribed to the fact that the bottom offers conditions favourable to their requirements, than to mechanical sedimentation, though some are no doubt deposited, for these are found

\* Ann. dell' Ist. d' Igiene Speriment. Univ. di Roma, iii. (1893) p. 515. See Ann. de Micrographie, vi. (1894) p. 138.

† See Brit. Med. Journ., 1894, No. 1753, p. 19.

‡ Bot. Gazette, xviii. (1893) pp. 383-95, 411-7, 439-47 (1 pl.). Cf. this Journal ante, p. 502.

in the slime in the vegetative and spore conditions. Both the water and slime species are few in number. Nearly all these bacteria liquefy gelatin, are killed by the action of direct sunlight, and none are pathogenic. All are aerobic and possess well-marked reducing properties, changing nitrates into nitrites. Two species of bacteria were found in the mud at a depth of 450 feet and 100 miles from land, and these were very frequent close in shore. Hence the forms found in bottom mud would seem to have a wide distribution. *Bacillus limosus*, an organism found by the author in the Bay of Naples at a depth of 3500 feet, is a common inhabitant of the mud of this part of the Atlantic.

The author describes in detail four forms which are the commonest among the few species of the flora found by him:—*B. limicola* sp. n., *B. pelagicus* sp. n., *B. litorosus* sp. n., *B. maritimus* sp. n.

**Filaments of Tubercles of Papilionaceæ.\***—M. M. W. Beyerinck finds, from experiments made with *Vicia lathyroides*, that the filaments of the Papilionaceæ tubercles consist of bacterial mucus, and that this mucus, which represents the cell-wall of the bacterium, has, in the course of the filament formation, either completely excluded the bacterial bodies or still includes some of them. It seems worthy of note that the bacteria still lying in the mucus have not the bacteroid form, the mucous investment forming an impenetrable covering which protects the bacteria from the metamorphosing action of the cell-protoplasm, owing to which influence the bacteria are converted into bacteroids.

**Action of Gravity on Bacterium Zopfii.†**—The interesting paper by Drs. R. Boyce and A. E. Evans on the action of gravity upon *Bacterium Zopfii* is preceded by a description of the organism, its morphological, biological, and cultural characteristics, and is illustrated by some excellent photograms. The most important of their remarks, however, refer to the phenomenon of negative geotropism exhibited by *B. Zopfii*. The experiments showed that a pinnate growth occurs when the surface of the medium is kept in or near the vertical, or when the culture is rapidly rotated in the horizontal. When the gelatin surface is horizontal, or slowly rotated in the vertical, the growth is irregular. In order to demonstrate the upward growth, the temperature and medium must be suitable. The action of gravity was tested by causing inoculated test-tubes to revolve slowly upon a clinostat; under these conditions the growth was irregular, while centrifugal force, like gravity, induced a regular growth. *B. Zopfii* is therefore negatively geotropic.

In connection with this communication, M. M. W. Beyerinck ‡ states that he has noticed the pinnate growth described by the English observers. At first geotropism was suspected, but a careful examination showed that the cause was the extreme sensitiveness of this organism to differences of temperature. The radiations are so influenced by thermotaxis that their direction is always towards the warmest place, and consequently their arrangement may be altered at will by suitably disposing the source of heat. Hence the penetration of *B. Zopfii* into an animal body is due to thermotaxis.

Perhaps the most noteworthy fact in regard to the organism is the way in which it grows into the gelatin, which is not liquefied.

\* Centralbl. f. Bakteriol. u. Parasitenk., xv. (1894) pp. 728-32.

† Proc. Roy. Soc., liv. (1894) pp. 300-12 (2 pls.). Cf. this Journal, 1893, p. 774

‡ Centralbl. f. Bakteriol. u. Parasitenk., xv. (1894) p. 799



**Experimental Production of Bovine Peripneumonia.\***—M. S. Arloing has produced typical bovine pneumonia in cattle by injecting pure cultivations of *Pneumobacillus liquefaciens bovis* into the lungs. There were the usual areas of pneumonic consolidation in the lungs, the fibrinous pleurisy and swelling of the lymphatic glands. The dose injected was 5 or 10 ccm. of cultures from the fourth to tenth generation, the injection being repeated for several successive days.

The source of the cultivations was a subcutaneous swelling near the root of the tail. When transferred to peptonized bouillon, and afterwards to gelatin plates, two different bacilli were isolated. One of these liquefied, the other did not; both were provided with numerous cilia, the non-liquefying was usually shorter than the other. Only the liquefying form (*Pneumobacillus liquefaciens bovis*) was used in the experiments.

**Secondary Foci in Experimental Diphtheria.†**—Drs. A. C. Abbott and A. A. Ghriskey describe very minute yellowish lens-shaped foci in the omentum of guinea pigs after subcutaneous injection of pure cultivations of diphtheria. On microscopical examination these deposits were found to consist of polynuclear leucocytes, the majority of which contained diphtheria bacilli. In the course of experiments it was found that injection of bouillon cultures, or of suspensions of bacilli in physiological salt solution into the testicles, gave satisfactory results. The amount injected varied from 0.4 to 0.7 ccm.

The method adopted for demonstrating the bacilli was to stain the tissues first with aqueous Bismarck brown solution, then wash in alcohol and stain with Gram's method. The bacilli were also stained with Löffler's alkaline methylen-blue solution. The authors suggest that the bacilli were carried through the lymphatic vessels by wandering cells.

**Bactericidal Power of Dog's Blood, and its Richness in Leucocytes.‡**—Dr. J. Havet finds from experiments made on dogs that the white blood corpuscles almost or altogether disappear when microbial products are injected into the blood, and this disappearance is coincident with partial or total loss of bactericidal power. As the leucocytes reappear the bactericidal power returns *pari passu*. When living cultures are injected into the tissues, the stage of hypoleucocytosis is accompanied by a diminution of the bactericidal power, and conversely hyperleucocytosis by increase.

This increase is due to the presence of leucocytes in greater numbers, and is not the result of some newly acquired property of the serum. No fixed relationship between richness in leucocytes and bactericidal power can be established, for the leucocytes may be weakened either by a previous digestion of microbes, or by the microbial poison. Leucocytes, in case of two kinds of organisms, may incorporate both or only one, according to the medium in which they are acting.

**Physiological Effect of the Soluble Products of Pyogenic Staphylococci.§**—Sig. J. Salvioli, after finding that intrajugular injection of

\* Comptes Rendus, cxix. (1894) pp. 143-6.

† Johns Hopkins Hospital Bulletin, iv. (1893) pp. 29-31 (6 figs.).

‡ La Cellule, x. (1894) pp. 221-47.

§ Berlin. Med. Wochenschr., 1893, No. 13. See Centralbl. f. Bakteriol. u. Parasitenk., xv. (1894) p. 1007.



bouillon free from pepton or serum, from which the proteids coagulable by heat had been removed, had no influence on the animal organism, especially that of the dog, injected cultures of *St. pyogenes aureus* suspended in this fluid medium, so that the dose corresponded to about 7-8 ccm. per kilo. of the body weight. There occurred a significant fall of blood pressure, the respiration was hurried, the animal had convulsions, accompanied by defæcation, micturition, and vomiting. The blood lost its coagulability, remaining fluid for hours, even until it began to decompose. Dead cultures as well as germ-free filtrates had the same effect. Other liquefying bacteria, such as *Proteus vulgaris* and Finkler-Prior, exhibited similar effects. The author lays it down that these phenomena are produced by bacterial ferments, and that they are to be obtained from alcoholic precipitates of the filtrates, as these showed the same effects as the bacteria. Rabbits were less sensitive. Coagulability and fall of blood pressure do not seem to be directly related.

No other specific poisons than these enzymes were found, though the author believes that their action may have been masked by that of the enzymes.

**Phagocytosis and Actinomycosis.\***—MM. Pawlowsky and Maksutof consider that actinomycosis exhibits fine examples of the struggle between the parasite and the organism; for directly the latter has been invaded, it is surrounded by phagocytes (mononucleated leucocytes and young connective tissue cells) which, developing into large epithelioid cells, seize on isolated parasites or groups thereof. If now the cells possess sufficient vitality, the parasites are destroyed. But if, on the contrary, the parasite be victorious, it leaves the cell which has perished, and then excites the advent of new phagocytes, owing to its chemiotactic influence. These form a barrier around the parasite, seize on its terminal swellings, arrest its development, and end by inducing therein involution forms and retrogressive degeneration, which terminate in the formation of hyaline bodies. These hyaline bodies, though smaller and less frequent than in rhinoscleroma, have a similar origin and are parasitic products.

**Growth of Streptococcus longus in Bouillon.†**—The experiments recorded by Herr R. Waldvogel are directly connected with those of Knorr, who found that he could immunise animals by one species of streptococcus against other streptococci. These results raise the question of the specific distinctness of streptococci. The author cultivated a long streptococcus in bouillon, and inoculated mice therewith, and found that the two forms of streptococcus, the long and short chains, could be obtained by passing one and the same kind through animals—using, in fact, a living cultivation medium. The biological characters were not disturbed by these morphological changes.

**Differences between Bacterium coli commune and Bacillus typhosus.‡**—Mr. H. S. Fremlin has compared the morphological, cultural, and pathogenic properties of *Bact. coli commune* of man and of other animals, not only with one another, but also with the *Bacillus*

\* Ann. Inst. Pasteur, vii. (1893) pp. 544-9 (20 figs.).

† Centralbl. f. Bakteriöl. u. Parasitenk., xv. (1894) pp. 837-9.

‡ Archiv f. Hygiene, xix. (1893) pp. 295-316. Cf. this Journal, ante, p. 388.

*typhosus*. He finds that *Bact. coli* presents two appearances on gelatin, viz. a membraniform film and points. Gelatin is not liquefied; milk is coagulated; and on saccharated media gas is developed. Spore-formation was not observed. This microbe is easily stained with anilin pigments, but not by Gram's method. In size and shape the organisms obtained from different sources were much alike, though those from man exhibited very lively movements, while those from the rabbit were very sluggish. Potato cultivations exhibited well-marked colour differences, the *Bact. coli* being mostly of an orange hue. *Bac. typhosus* was scarcely visible.

The author finds that there are distinct differences between the two kinds of bacteria. *B. typhosus* is more mobile, and possesses several flagella which are easily stained. *Bact. coli* has usually only one flagellum which is difficult to stain. *Bact. coli* gives the indol reaction (1 ccm. of 0.02 per cent. nitrite of potash and some diluted sulphuric acid are added to a pepton cultivation). *Bac. typhosus* does not. The latter has a great tendency to form filaments from the connection of several individuals. *Bact. coli* is a rodlet 1-3 mm. long and about 0.8 mm. broad, usually single, though occasionally in pairs. *Bact. coli* grows faster on agar and gelatin than *Bac. typhosus*.

Dr. Inghilleri\* points out that since Rodet and Roux published their researches on the identity of these bacteria, their observations have been frequently supported and controverted. The balance of opinion seems to incline to the view that, while there are actual differences between the two organisms, they have probably originated from the same stock. According to the author these microbes behave differently in media containing amygdalin, for while the reaction of bouillon cultures of *B. coli* is acid and the odour of bitter almonds can be perceived in about thirty-six hours, the reaction of a culture of typhus is alkaline. This difference is supposed to be due to the fact that *B. coli* acts like emulsin in splitting up the complex molecule of the glucoside into the simpler one of grape sugar, prussic acid, and benzaldehyd. The acid reaction depends on the fact that *B. coli* acts successively on glucose, and decomposes its molecule into carbonic acid and lactic acid. The author made use of the Gruber-Bercholtz reaction to demonstrate glucose. The prussic acid was first eliminated by the aid of caustic potash and then demonstrated by means of the Berlin blue reaction. In the typhus cultures nothing of the sort takes place.

The author is of opinion that this property of *B. coli* is associated with the life of the bacillus, since a sterilized culture has no such action.

**Cholera Vibrio and Diagnosis of Cholera.** †—Prof. M. Gruber, while agreeing with Koch's views in the main, rejects most of the tests supposed to be diagnostic of the *V. cholerae asiaticæ*. The only one which the author finds to be of any value is the microscopical appearance of quite young colonies in 10 per cent. gelatin. The observations, however, must be made under certain definite conditions to be reliable, and the colonies inspected under magnifications of 80 to 120. The gelatin must be always of the same composition, prepared according to the method of Petri and Maassen, and rendered sufficiently alkaline to give the reaction with rosolic acid.

\* Centralbl. f. Bakteriol. u. Parasitenk., xv. (1894) p. 821.

† Lancet, July 7 and 14, 1894

**Pyelonephritis due to Staphylococcus pyogenes aureus.\***—M. Delpech describes a case of primary pyelonephritis in a girl 17 years of age. There was pain in the right lumbar region, temperature 38°–39°, marked polyuria, and during the first days of the illness pus in the urine. These symptoms disappeared suddenly after a duration of a fortnight. During convalescence small quantities of albumen were present in the urine. The bacteriological examination, conducted by Netter, showed the presence of *St. pyogenes aureus* and the absence of other pyogenic organisms.

**Bacillus typhi murium and Caucasian Field Mice.†**—Dr. M. Lunkewitsch has made some practical experiments with *Bacillus typhi murium* Löffler on the Caucasian field mouse, and found that this micro-organism is pathogenic to the Caucasian *Arvicola arvalis*, killing it quickly and surely. The procedure advised is to saturate bread with infected straw infusion, one agar tube cultivation being mixed with one litre of the infusion. *Bac. typhi murium* is also pathogenic to house mice, but to a much less marked degree, though when subcutaneously injected the animals died in 24 hours. The death of house mice was noticed to be preceded some three or four days before death by paresis of the hind legs and later of the fore limbs.

**Microbes in Normal Urethra of Women.‡**—Dr. N. Gawronsky records the result of a large number of examinations of the healthy female urethra. Out of sixty-two cases there were positive results in fifteen, i. e. 24 per cent.; *Streptococcus pyogenes*, three times; *Staphylococcus pyogenes aureus*, eight times; *St. pyogenes albus*, once; *Bact. tholoeideum* Gessner, once; *Bact. coli commune*, twice. The occurrence of the last is noteworthy, as its existence in cases of cystitis is well known. The author's negative results are also interesting, none being found in some cases of para- and perimetritis, in one case diagnosed as gonorrhœa, or in three cases of pregnancy.

**Pathogenic Action of Bacillus pyocyaneus on Human Beings.§**—Dr. Kossel finds, from observations made with pus from the middle ear, that *Bacillus pyocyaneus*, while mostly harmless to adults, is dangerous to children and more so to infants. *B. pyocyaneus* was found eight times out of fifty-two examinations of pus in the middle ear of infants.

With regard to skin wounds, *B. pyocyaneus* is not primarily harmful, though it may become so secondarily. In children, by gaining access to the circulation, it may excite meningitis, or be pathogenic indirectly from absorption of its metabolic poisonous products.

**Urobacillus liquefaciens septicus.||**—M. D. Chapman, in a contribution to the pathogenesis of urinary infection, chiefly discusses a particular organism, *Urobacillus liquefaciens septicus*. The vitality of this organism is considerable, and its pathogenic properties great. Mice die in a short time, and rabbits barely survive a week. When injected subcutaneously or into the peritoneal sac, suppuration takes place almost

\* Bull. Med., 1892, p. 1095. See Bot. Centralbl., 1894, Beihefte, p. 156.

† Centralbl. f. Bakteriol. u. Parasitenk., xv. (1894) pp. 845–6.

‡ Münchener Med. Wochenschr., 1894, No. 11. See Centralbl. f. Bakteriol. u. Parasitenk., xvi. (1894) p. 84.

§ Zeitschr. f. Hygiene u. Infektions., xvi. pp. 368–72. See Centralbl. f. Bakteriol. u. Parasitenk., xvi. (1894) p. 33.

|| Thèse, Montpellier, 1893, pp. 65. See Centralbl. f. Bakteriol. u. Parasitenk., xvi. (1894) p. 38.



directly. Bouillon cultures are more virulent than those on gelatin, agar, or blood serum. This bacillus produces a ptomain which exerts a similar though less powerful action.

- BABÈS, V.—Ueber die durch Streptokokken bedingte acute Leberentartung. (On acute Hepatic Degeneration due to Streptococci.)  
*Virchow's Archiv*, CXXXVI. p. 1.
- BURRI, R.—Ueber einen milzbrandähnlichen Bacillus aus südamerikanischem Fleischfüttermehl. (On a new Bacillus like that of Splenic Fever from South American Fodder.)  
*Hygien. Rundschau*, 1894, pp. 339-42.
- CHARBIN, A., & A. DISSARD—Les propriétés du bacille pyocyanogène en fonction des qualités nutritives du milieu. (The Properties of *Bacillus pyocyanogenes* as affecting the Nutrient Qualities of its Medium.)  
*Compt. Rend. Soc. Biol.*, II. (1893) pp. 182-6.
- CRAMER, E.—Die Zusammensetzung der Sporen von *Penicillium glaucum* und ihre Beziehung zu der Widerstandsfähigkeit derselben gegen äussere Einflüsse. (The Composition of the Spores of *P. glaucum*, and its relation to their power of withstanding external influences.)  
*Arch. f. Hygiene*, XX. p. 197.
- CHVOMSKI, K.—Bakteriologische Untersuchungen des Grund- und Leitungswassers der Stadt Basel. (Bacteriological Investigation of the Standing and Flowing Water of Basle.)  
*Zeitschr. f. Hygiene*, XVII. (1894) pp. 120-63.
- GARSZŃSKI, W. S.—Sind die Choleraspirillen im Stande zu überwintern? (Can Cholera-spirilla survive the Winter?)  
*Arch. Lab. Obsh. Patol. p Imp. Varshav Univ.*, 1893, pp. 95-120.
- GRAWITZ, E., & W. STEFFEN—Die Bedeutung des Speichels und Auswurfs für die Biologie einiger Bakterien. (The importance of Saliva and Sputum for the Biology of certain Bacteria.)  
*Berl. Klin. Wochenschr.*, 1894, pp. 419-21.
- ITZEROTT, G.—Bakterienkunde. Ein kurzer Leitfaden für Studierende und Aertze. (Bacteriology; Brief Guide for Students and Physicians.)  
Leipzig, 1894, 12mo, viii, and 128 pp., 48 figs.
- JACKSON, G. T. H.—The Barber-shop as a Source of Contagion.  
*Med. Record*, 1894, p. 426.
- KEDROWSKI, W.—Ueber zwei Buttersäure produzierende Bakterienarten. (On two new Species of Bacteria which produce Butyric Acid.)  
*Zeitschr. f. Hygiene*, XVI. (1894) pp. 445-57.
- KOLLE—Beiträge zu den experimentellen Cholera-Studien an Meerschweinchen. (Experimental Cholera Studies on Guinea-pigs.)  
*Zeitschr. f. Hygiene u. Infektionskrankheiten*, XVI. p. 329.
- KRUSE, W.—Kritische und experimentelle Beiträge zur hygienischen Beurteilung des Wassers. (Critical and Experimental Contributions to the Hygiene of Water.)  
*Zeitschr. f. Hygiene*, XVII. (1894) pp. 1-58.
- KÜTHE, F. P. H.—De ontwikkeling en het tegenwoordig standpunt der bacteriologie. (The Development and present Standpoint of Bacteriology.)  
Haarlem, 1893, 8vo, 205 pp.
- LEO, H., & R. SONDERMANN—Zur Biologie der Cholera-bacillen. (On the Biology of the Cholera-bacilli.)  
*Zeitschr. f. Hygiene*, XVI. (1894) pp. 505-12.
- MATHEWS, A. P.—On Wurtz's Method for the Differentiation of *Bacillus typhi abdominalis* from *Bacillus coli communis* and its Application to the Examination of Contaminated Drinking Water.  
*Technol. Quarterly*, 1893, vi. pp. 241-51.
- MCWEENEY, E. J.—Demonstration of the Typhoid Bacillus in suspected Drinking Water by Parietti's Method.  
*British Med. Journ.*, No. 1740, 1894, pp. 961-2.
- RATTONÉ, G.—Dei microorganismi, con speciale riguardo alla etiologia e profilassi delle malattie infettive. Parte I. (Micro-organisms, with special regard to the Etiology and Prophylaxis of Infective Diseases.)  
Turin, 1894, 8vo, 228 pp.
- REMY, L., & E. SUGG—Recherches sur le bacille d'Eberth-Gaffky; caractères distinctifs du bacille de la fièvre typhoïde; procédés pour le retrouver dans les eaux potables. (Researches on the Bacillus of Eberth-Gaffky; the Distinctive Characters of the Bacillus of Typhoid Fever; Methods for finding it in Drinking Water.)  
*Ann. Soc. Méd. de Gand*, 1893, pp. 11, 106, 158, 244.
- PFEIFFER, R.—Studien zur Cholera-ätiologie. (Studies on the Etiology of Cholera.)  
*Zeitschr. f. Hygiene u. Infektionskrankheiten*, XVI. p. 268.
- ZENTHÖFER—Ueber das Verhalten der Cholera-culturen in Hühnereiern. (On the Characters of Cholera-cultivations on Fowls' Eggs.)  
*Zeitschr. f. Hygiene u. Infektionskrankheiten*, XVI. p. 362.



MICROSCOPY.

a. Instruments, Accessories, &c.\*

(1) Stands.

FIG. 55.

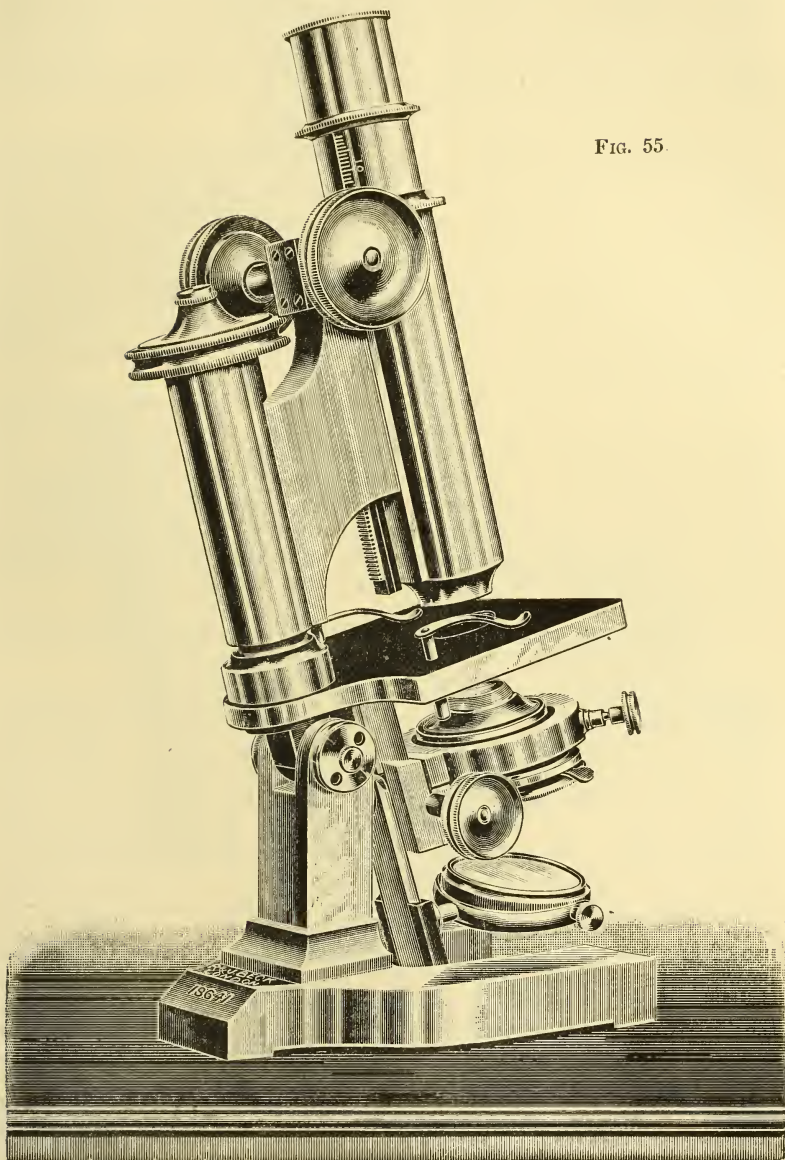

\* This subdivision contains (1) Stands; (2) Eye-pieces and Objectives; (3) Illuminating and other Apparatus; (4) Photomicrography; (5) Microscopical Optics and Manipulation; (6) Miscellaneous.

**Messrs. R. and J. Beck's Large "Continental" Model Microscope.**—This instrument (fig. 55) is on the model of the Continental Microscope, the special feature being the improved slow motion, which, Messrs. Beck claim, is extremely delicate, and being made without adjusting pieces cannot become deranged. The instrument has a rack and pinion and centering substage carrying condenser with iris diaphragm. The draw-tube is nickel-plated and graduated in millimetres. The whole instrument is heavy, rigid, and compact.

**Koristka's Microscopes.\***—The large model I *a* (fig. 56) is provided with a movable stage having two rectangular movements besides the movement of rotation about the optic axis. Each of the rectangular movements is of the extent of 20 mm., so that a space of more than 400 sq. mm. can be explored. A vernier for each movement allows of readings to 1/10 mm. The movements are sufficiently rapid, and at the same time of absolute precision. By means of the verniers and scales any given point of a preparation can be quickly found again. The stage is specially intended to hold the ordinary glass slide, but allows of the adaptation of slides of any dimensions.

The small model IX. (fig. 57) has the base and column of nicked cast iron. The stage has dimensions 75 by 70 mm., and the body-tube has a fixed length of 16 cm. The rack-and-pinion movement is of special construction, so that the smallest displacements can be made, and it is possible to focus for magnifications of more than 300 diameters. The instrument is provided with a concave mirror with lateral adjustment, and with diaphragms cut in a disc applied to the under surface of the stage, so that it can be rotated and the central position of each aperture marked by a catch.

This stand is specially intended for small schools, as an instrument of instruction for boys.

**Koristka Mineralogical Microscope.†**—The model C (fig. 58) for mineralogical work, has coarse-adjustment by rack and pinion, and fine-adjustment by micrometer-screw with head divided into 5/1000 mm. The rotating stage has a diameter of 100 mm. and is divided in degrees with a vernier reading to 10'. There are divisions on the stage for the orientation of the preparation. The arrangements for polarized light, and for passing from convergent polarized light to parallel polarized light, are very simple and rapid. The double mirror is adjustable laterally and in height. The polarizing nicol has a large field. The analyser has a circle divided in degrees, and allows of the use of any eye-piece and also of the introduction of other accessories between the eye-piece and the analyser. There is a slide-piece for the reception of Klein's plate or other accessory. A large opening in the body-tube allows of the introduction of a second analysing nicol between the objective and the eye-piece. The nicol is so adjusted as to produce no displacement of the image, and is united to a lens which maintains the constancy of the focal length of the system of objective and eye-piece. This nicol, which is of the Glan-Thompson construction, does not greatly restrict the field of view.

\* F. Koristka, *Catalogo Illustrato Descrittivo*, N. 7, Milan, 1894. † *Op. cit.*

FIG. 56.

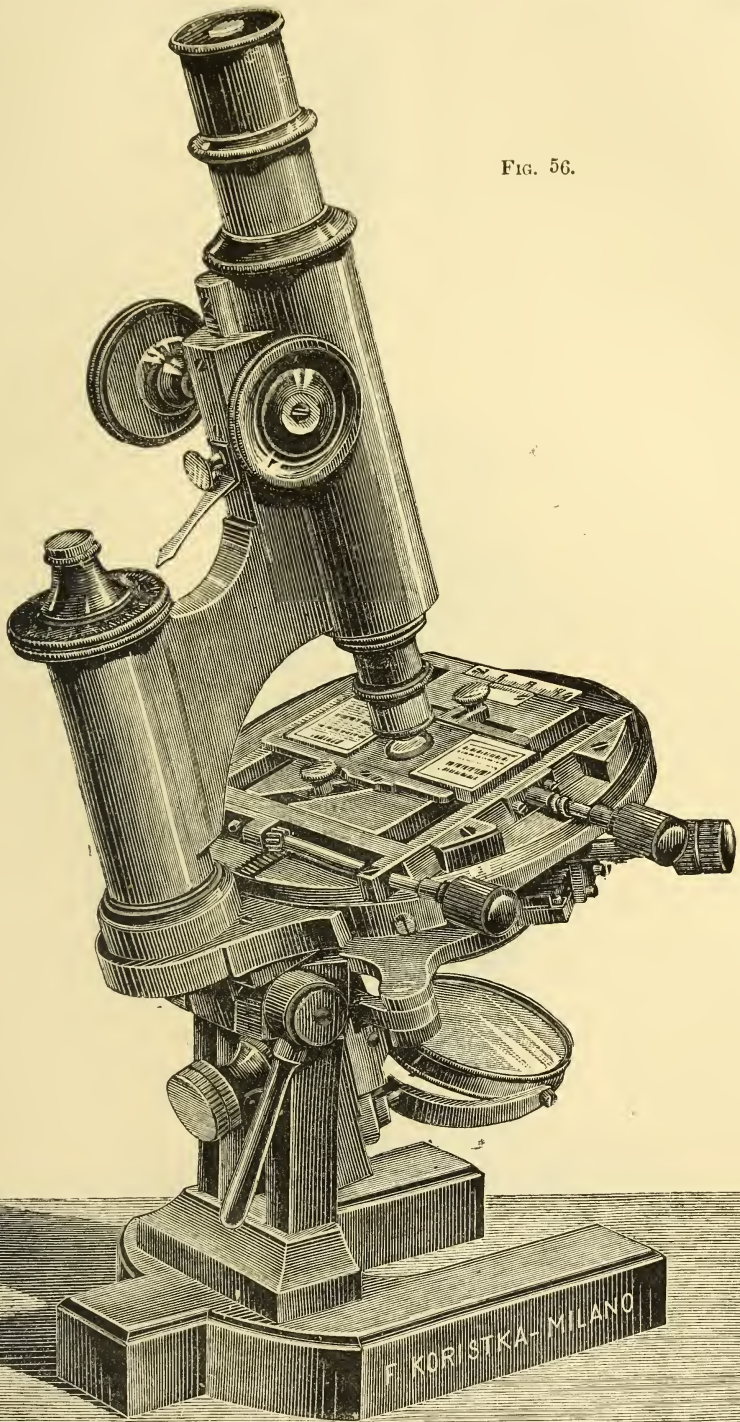



FIG. 57.

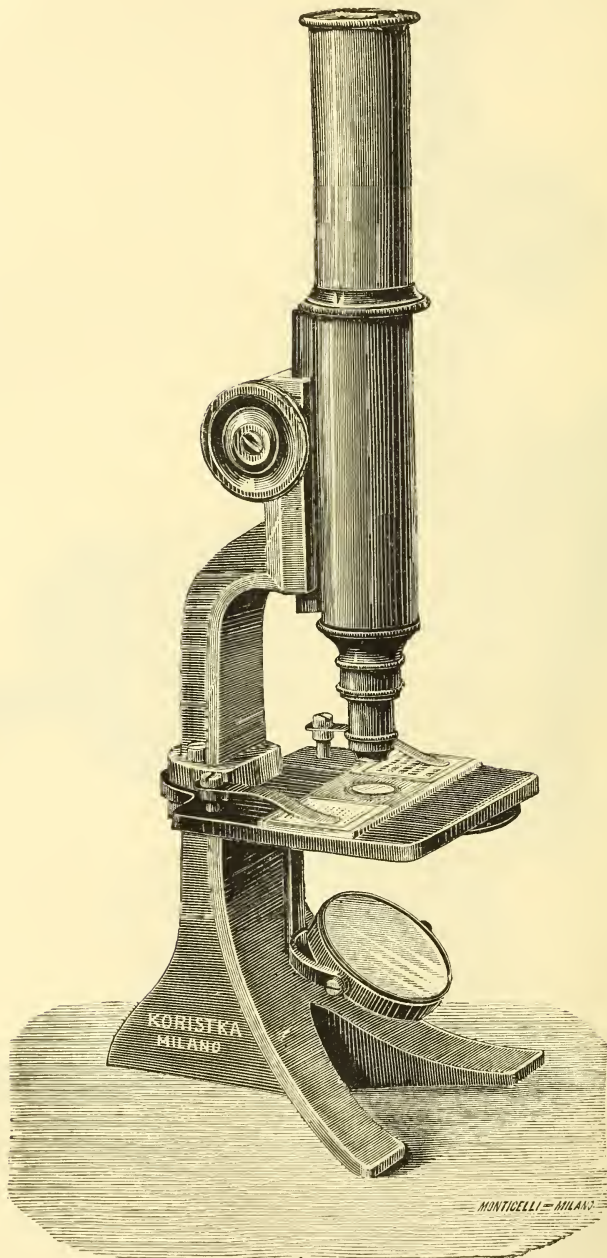
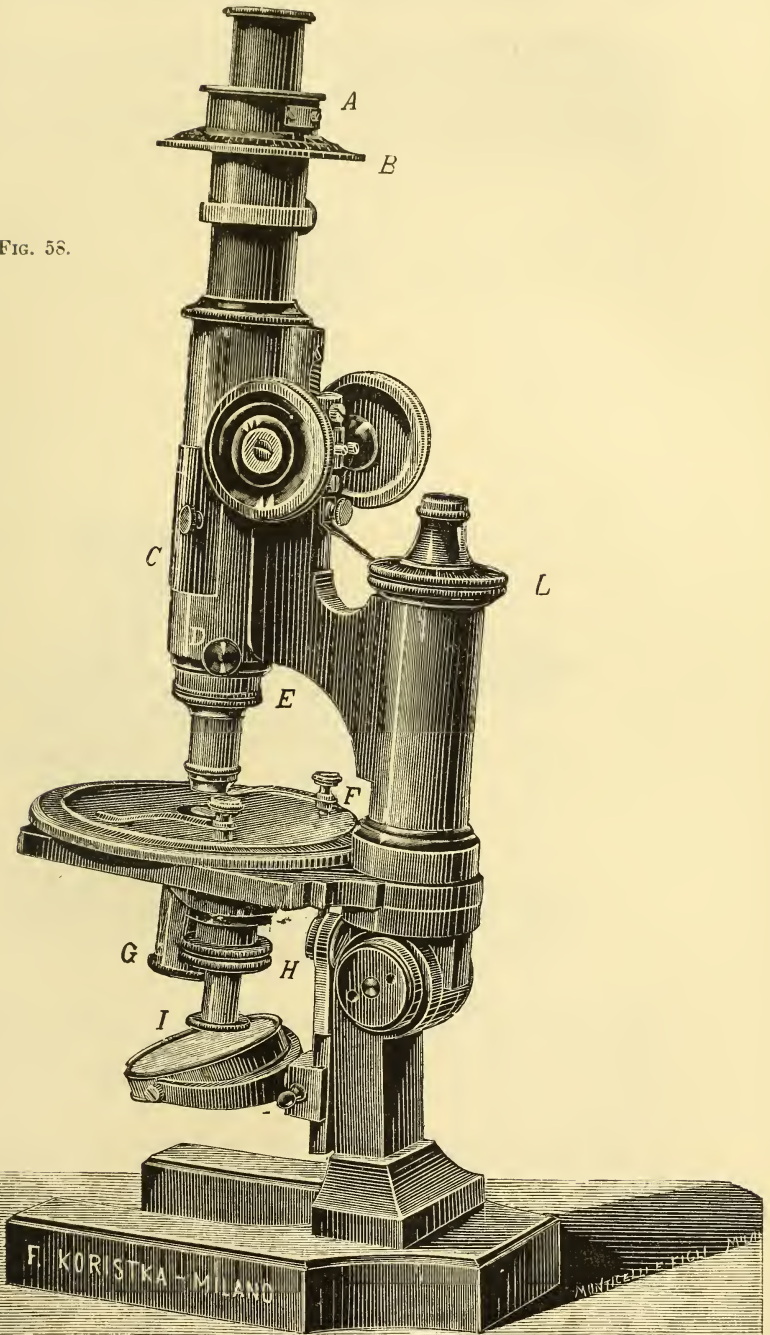

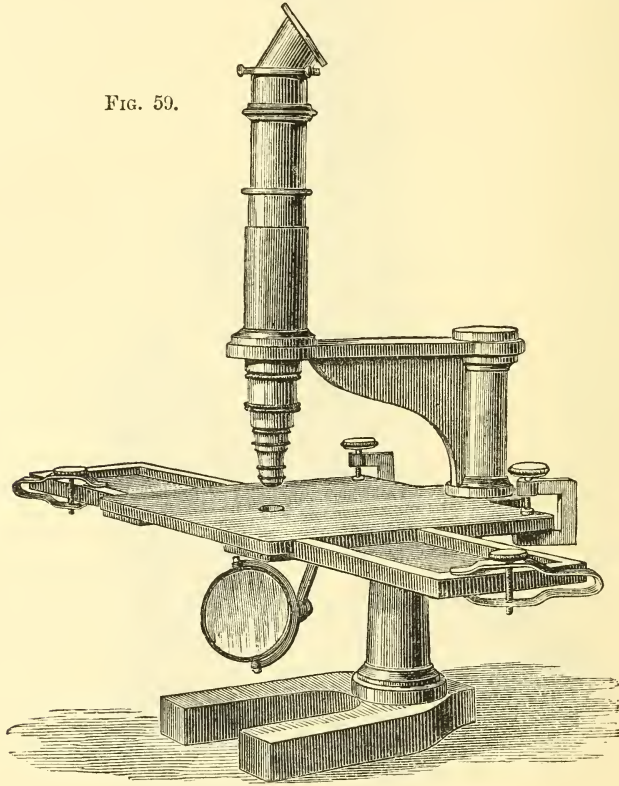

FIG. 58.



**Koristka Microscope.\***—The stand represented in fig. 59 was constructed according to the design of Prof. C. Giacomini, for the examination of the interior of the human brain. The square stage, of 16 cm. width, can be enlarged by the addition of two lateral wings, each 40 cm. long, so that preparations of more than 50 cm. length can be examined.

FIG. 59.



The coarse-adjustment is by sliding in the tube, the fine by micrometer movement of 5 mm. extent. The double mirror is laterally adjustable. There are clamps, &c., for fixing the preparations. For greater convenience of observation the instrument can be provided with an erecting prism.

**Practical Instructions for Making a Student's Microscope.†**—Mr. J. Swift gives a series of working drawings with practical instructions which should enable a good amateur brass-worker to construct a useful and efficient Microscope. A simple form of small hand-planing machine is sufficient for the purpose, but in the absence of such a machine the dovetail slides shown in fig. 60, *a*, *c*, *d*, may be filed to the required

\* F. Koristka, *Catalogo Illustrato Descrittivo*, N. 7, Milan, 1894.

† *English Mechanic*, lix. (1894) pp. 548 and 9.

angle by means of a small protractor, and screwed on. The woodcuts are drawn to exactly half size so that wood patterns may be easily made from them. In making the patterns for the brass castings, the female dovetails as in figs. *c* and *d* should be left solid. The slot shown in fig. 60 should be cut with an ordinary circular saw and screws inserted so that the dovetails can be pulled down to fit the male slides. In fig. 61 *a* is shown the optical body and draw-tube.

A light ring about  $\frac{3}{8}$  in. from the top is soldered upon the draw-tube, and two stops to prevent internal reflections are fitted inside. The upper stop is fitted about  $\frac{1}{8}$  in. below the total length of the body

FIG. 60.

FIG. 61.

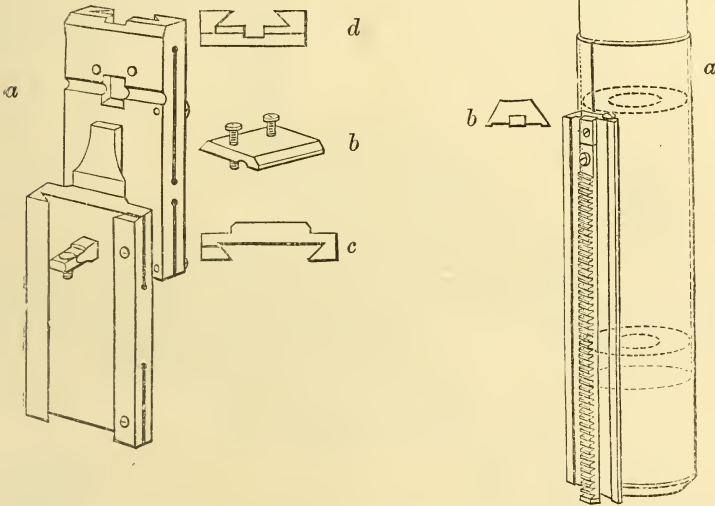

of the eye-piece when this is inserted in the tube; the second stop, with aperture of about  $\frac{6}{10}$  in. in diameter, is nearly at the lower end. At the end of the body-tube a brass casting is soldered, which must be screwed to the standard of the Royal Microscopical Society. The total length of the optical tube should be 160 mm. To the body is soldered a gun-metal dovetail (fig. 61 *b*) which slides into the upper part of fig. 60 *a*. A similar slide is soldered on to a tube as in figs. 62 *a* and *b*, to form the main portion of the fine-adjustment. A section of the fine-adjustment is seen in fig. 63. The screw should be about 50 threads to the inch, and is made out of No. 20 pianoforte wire; its point bears upon a hardened steel stud.

The rack-and-pinion coarse-adjustment is of the spiral form originally patented by Messrs. Swift and Sons. A piece of steel pinion wire of 12 leaves and  $2\frac{1}{2}$  tenths in diameter is taken, and the ends hammered flat so that one can be held in a bench vice and the other clamped by a hand vice; the pinion wire is then twisted through a right angle, when

it is geared into the rack. The teeth of the rack should be 18 to the inch and cut at an angle of about  $15^\circ$  less than a right angle. When the pinion has been turned with its proper bearings and the milled head

FIG. 62.

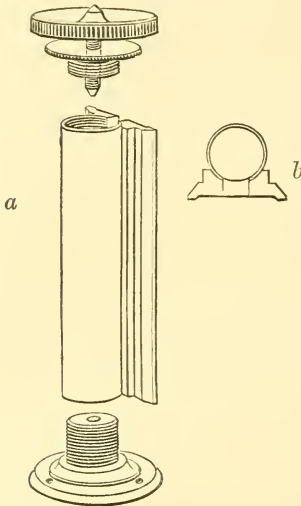

FIG. 63.

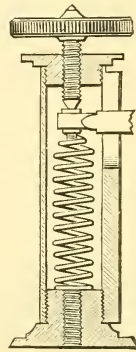

FIG. 64.



fitted on, the borings should be broached taper; the hollow and square-hole in fig. 60 *a* should be made to receive it and the plate (fig. 60 *b*) fixed on with two screws. The bar on optical tube (fig. 61 *b*) must be care-

FIG. 65.

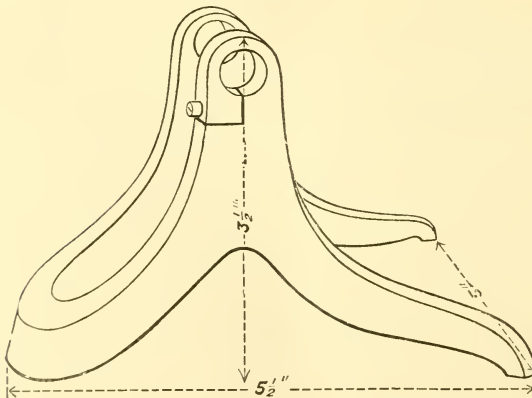
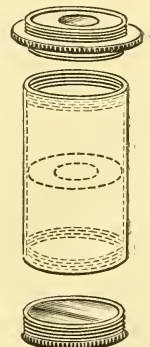

FIG. 66.



fully adjusted to female fitting (fig. 61 *a*), and a little pumice powder and oil can be used to secure a perfect fitting.

The tube beneath the stage for carrying the apparatus should be of



the usual size, viz.  $1\frac{1}{2}$  in. in diameter. The mount holding the mirror is gimballed in a stout ring of well-hammered brass. Between the gimbal and the screw is a brass collet which fixes the gimbal on to the sliding tube. The tail-piece on which the mirror slides is shown in fig. 64.

The tripod (fig. 65) should be 5,16 in. thick. One of the holes of the tripod has a saw-cut at right angles, and is fitted with a screw to produce the required tension on the axial motion of the instrument.

The lower field lens of the eye-piece should be  $2\frac{1}{2}$  in. solar focus, and the eye or upper lens  $1\frac{1}{4}$  in. focus. Length of tube and diameter of stop are given in fig. 66.

### (3) Illuminating and other Apparatus.

**Koristka Camera Lucida after Nachet.\***—In the camera lucida represented in fig. 67 the prism has one surface gilded and transparent according to the design of Prof. G. Govi. The layer of gold allows of

FIG. 67.

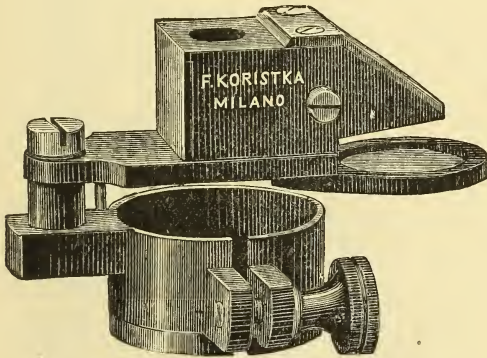

the transmission of the image given by the eye-piece, and at the same time reflects to the eye the image of the pencil and drawing paper.

### (4) Photomicrography.

**Koristka Photomicrographic Cameras.†**—The large model seen in fig. 68 has a double bellows, each half of which has an independent movement. The stage supporting the stand is of cast iron and is provided with levelling screws. The arrangement for moving the micrometer screw at a distance is of special construction, and can be used for magnifications of more than 5000 diameters with as much precision as if the head of the micrometer screw were moved directly by hand. The camera is provided with a ground-glass plate and a transparent plate for more exact focusing, and with slides of sizes 9 by 12, 12 by 16, and 18 by 24 cm. The total length of the camera when fully extended is 1.80 m.

The small model, shown in fig. 69, has a base-plate with guides

\* F. Koristka, *Catalogo Illustrato Descrittivo*, N. 7, Milan, 1894. † *Op. cit.*

Fig. 68.

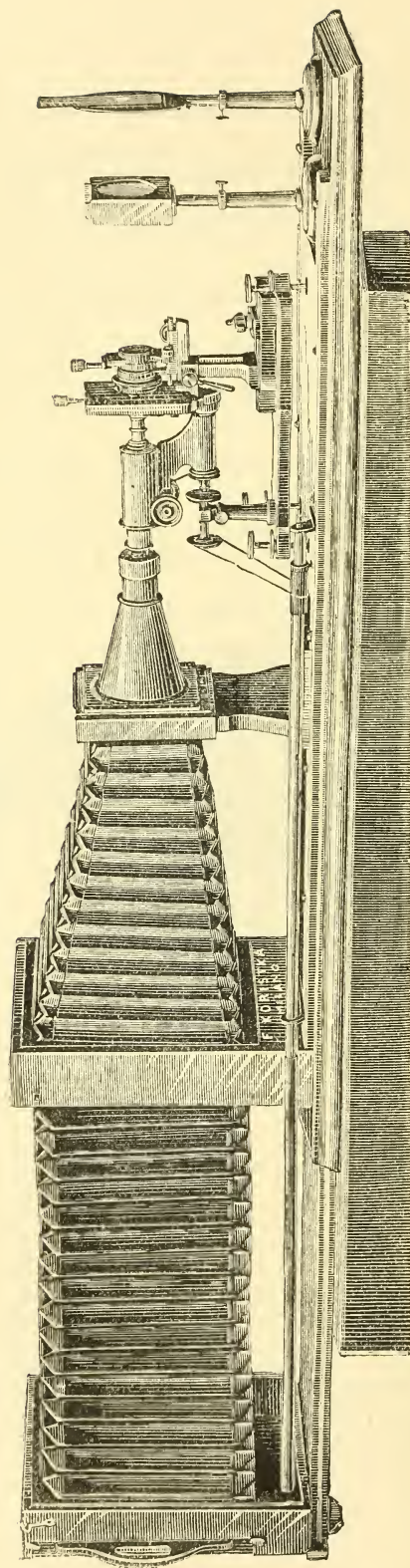
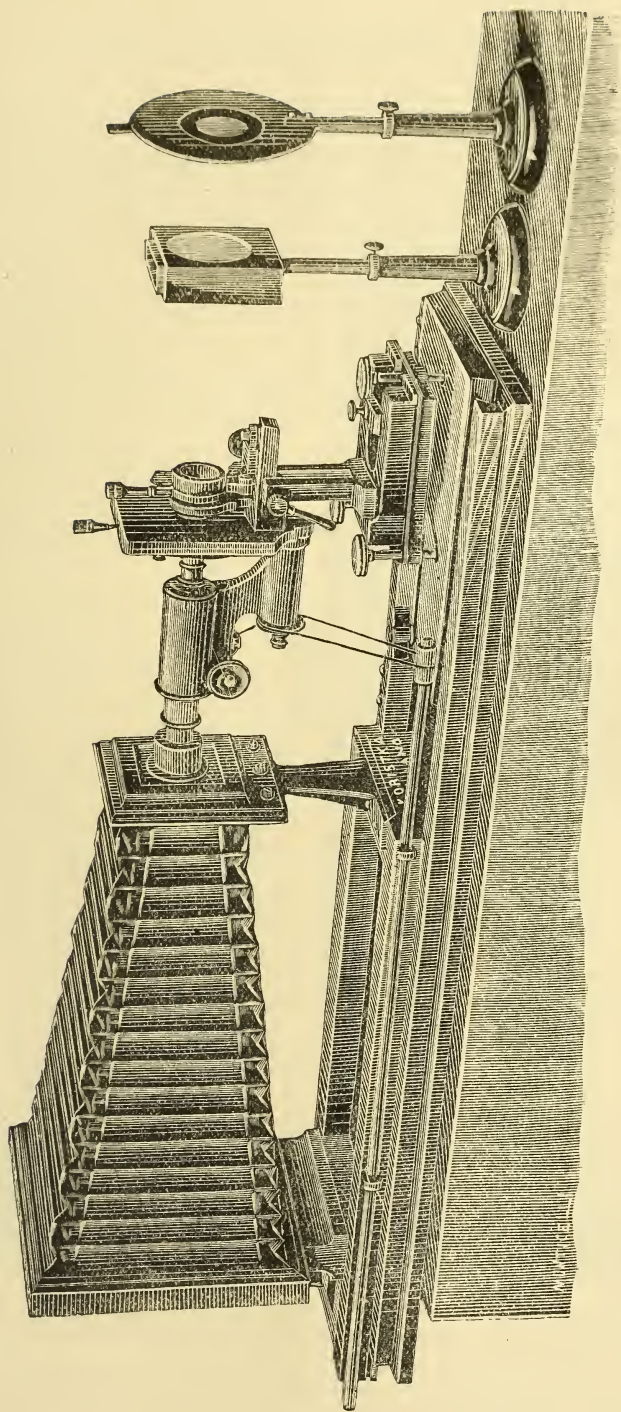

FIG. 69.





1 m. in length on which run independently the frame carrying the bellows and the wooden plate which supports the cast-iron stage carrying the stand. At one extremity of the frame carrying the bellows is fixed the small mouth of the bellows, while the other extremity is attached

FIG. 70.

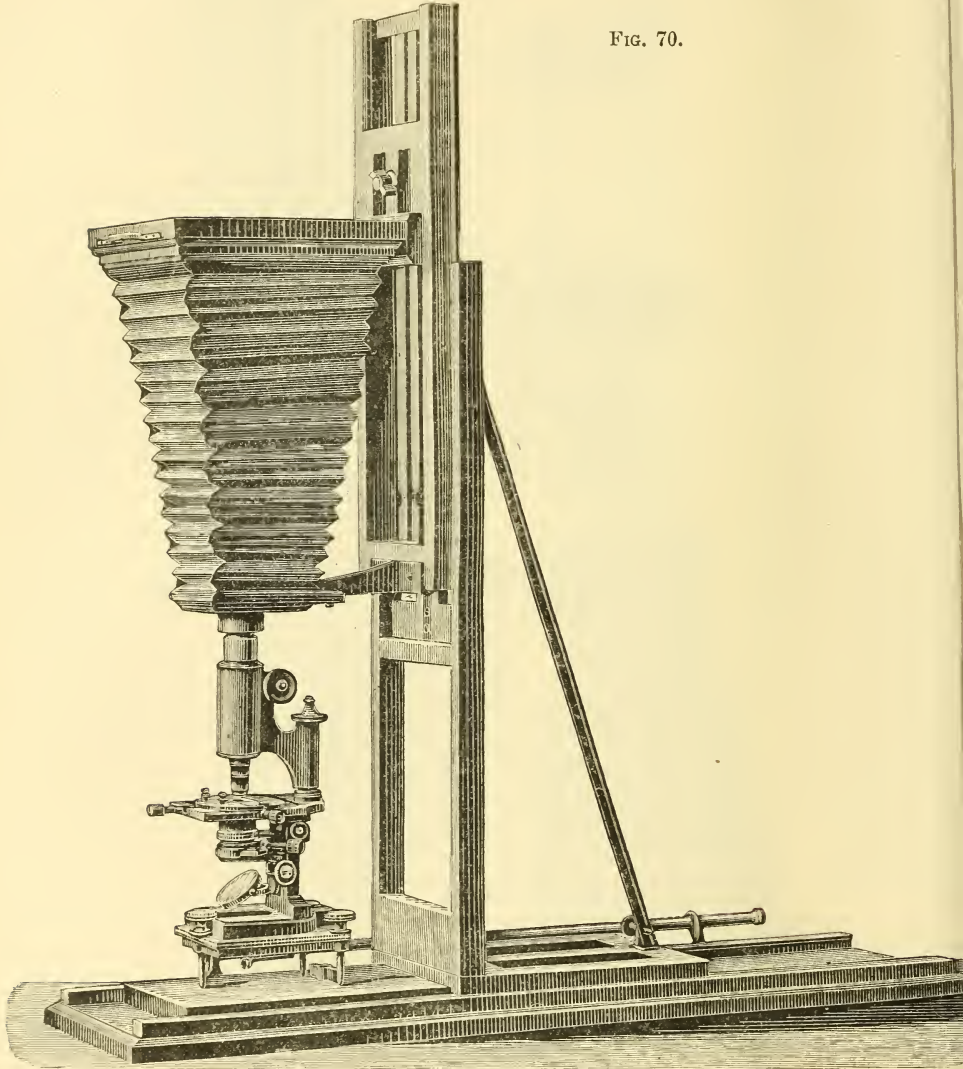

to a smaller frame sliding in the first, and can be fixed in any position by a clamping screw. The total length of the bellows is about 0.70 m. The arrangement for moving the micrometer screw at a distance is very sensitive. The camera is provided with a ground-glass plate and transparent plate, and with slides of sizes 9 by 12, 12 by 16, and 18 by 18 cm.



The vertical camera represented in fig. 70 is the preceding camera (fig. 69) with the addition of a special frame for fixing it vertically so that it may be used for photographing liquid preparations.

**Comparison between Petroleum, Gas, and the Auer Incandescent Light with respect to their Usefulness for Photomicrographic Work.\***—Herr R. Neuhauss comes to the conclusion from his experiments that—

(1) The Auer incandescent light is very convenient for photomicrography, and the time of exposure is four times shorter with this light than with petroleum.

(2) Petroleum light is to be preferred to the Argand gas-light.

(3) No advantage for photomicrographic purposes is gained by the addition of camphor to petroleum.

The disadvantage attending the use of the Auer light—that by the projection of the source of light in the plane of the image the luminous network is seen, and so no uniformly illuminated field of view obtained—is obviated by not exactly focusing the image of the source of light. No sensible diminution of the illumination is thereby produced.

#### (6) Miscellaneous.

**Plea for Systematic Instruction in the Technique of the Microscope at the University.†**—Mr. Jacob D. Cox, in his presidential address to the American Microscopical Society, urges the desirability of a somewhat extensive course of instruction in the technique of the Microscope in Universities. He considers that the University is the place where the worker should be able to find everything of value which has been invented in connection with the Microscope, as well as opportunity to test its value by actual comparison in use. The exhibits of Microscopes and microscopical apparatus at each of the great exhibitions were of great value in affording scientific visitors the opportunity of comparing what was being done in different countries; but of how much greater service would such exhibits be, if they were permanent at the centres of learning, open not only to inspection, but to continuous use under the guidance of expert teachers!

The author gives a brief analysis of the lines of work open to the microscopical student, and treats of the various points with regard to the technique of the Microscope which may be said to be still undecided. In the first place, in the case of the lenses the student needs a competent instructor to show him the differences between them, the purposes for which each is adapted, and the manner in which the aperture limits the power. In treating of immersion lenses the author insists on the need for collar-adjustment for cover.

The use of the eye-pieces opens another series of problems, as to the distance apart of objective and ocular, the size of the field-lens, and the relative values of the various forms of oculars.

The various ingenious devices which have been employed in the fine-adjustment, the use of the so-called sub-stage accessories, the advantages to be derived from oblique illumination and its relation to the

\* Internat. Med.-photogr. Monatschrift, i. (1894) pp. 29-30. See Eders Jahrb. f. Photogr. u. Reproduktionstechnik, vii. (1893).

† American Microscopical Society. Address of the President, 1893, 16 pp.

phenomena of diffraction, all afford interesting subjects of study. As regards the stage, the size and form best adapted for various purposes have to be considered. The relative advantages of small and large instruments have to be determined. The author refers those who say that the largest English instruments cannot be conveniently used in an upright position to Dr. Dallinger's method of using his Powell and Lealand upright, as illustrated in the new edition of Carpenter.

The author considers that all sound reasoning and practical experience agree in sustaining his proposition "that systematic and thorough training in the use of the Microscope is highly desirable, and that the University is the school to which we naturally look for the means to meet the want."

**Stereoscopic Vision applied to Diatoms.\***—Count A. F. Castracane points out the utility of binocular stereoscopic apparatus in microscopic observation and photography, particularly in relation to diatoms. He suggested and practised this manner of observation twenty years ago, but his example does not seem to have been followed, until recently—by Dr. G. Fritsch and O. Müller.

### B. Technique.†

#### (1) Collecting Objects, including Culture Processes.

**Apparatus for Anaerobic Cultivations.‡**—Herr W. Lubinski describes some apparatus which he has devised for the cultivation of anaerobic micro-organisms.

The first apparatus consists of a glass jar A, 25–28 cm. high and 15–17 cm. diameter, the upper part of which is expanded as shown in fig. 71 at B. Into A is fitted the part C which is provided with a sort of flange, perforated with two openings placed opposite one another. The part D is also provided with two openings, and a handle serves as a cover. When required for use a rubber tube is fitted on to the opening *a'* of the part C; this reaches to the bottom of the jar. The culture tubes all having been arranged in position, the cover D is put on, so that the openings *l* and *m* abut against those of the part C. All the cracks and joints of the apparatus must be smeared up with vaselin. Gas is introduced into the jar by the openings *l* or *m*, according to the specific gravity, if heavy through *m*, if light through *l*. When all the air has been driven out, a turn of 90° is given to the lid D. In order to prevent any diffusion of gases, the expanded portion of the jar which acts as a reservoir is filled with water. During incubation it is advisable to put a weight on the lid to prevent it being raised by the increased gas tension, though this may be avoided by filling the jar with warmed gas.

Another apparatus, fig. 72, is a glass jar of similar size to the last, and closed by a glass stopper. At opposite sides of the jar are two tubes, to which are adapted bulbs, something like Woulf's bottles, *t*<sub>1</sub> for the introduction of gas, *t*<sub>2</sub> for the exit of air. These bulbs are partially filled with fluid paraffin or vaselin. The upper bulb in *t*<sub>2</sub> is to

\* *Atti Accad. Pontif. de' Nuovi Lincei*, xlv. (1893) pp. 145–8.

† This subdivision contains (1) Collecting Objects, including Culture Processes; (2) Preparing Objects; (3) Cutting, including Imbedding and Microtomes; (4) Staining and Injecting; (5) Mounting, including slides, preservative fluids, &c.; (6) Miscellaneous.

‡ *Centrabl. f. Bakteriöl. u. Parasitenk.* xvi. (1894) pp. 20–5 (4 figs.).

prevent any back flow of fluid when the gas pressure is lowered from cooling of the apparatus. The gas is to be introduced by a gasometer or Kipp's apparatus.

FIG. 71.

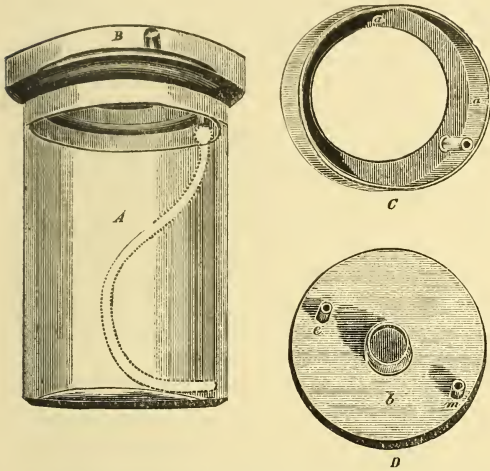
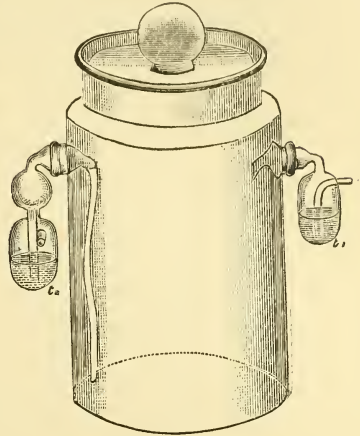

FIG. 72.



The author also describes his application of the methods of Liborius and Buchner to the cultivation of anaerobes.

**Bacteriological Examination of Air.\***—Dr. R. T. Hewlett finds that Sedgwick's method is the best for the bacteriological examination

of air. A glass tube of special form is employed. This consists of an expanded portion A B (fig. 73) about 15 cm. long and 4.5 cm. in diameter; one end of this is contracted so as to form a neck A, 2.5 cm. in diameter and in length; to the other end is fused a glass tube B D, 15 cm. long and 0.5 cm. in diameter. The neck of the tube is plugged with cotton-wool, and two wool plugs are inserted in the narrow tube, one at its open end D, the other about 6-8 cm. from the wide part C. The whole is then sterilized. When cool the narrow part of the tube, from its origin at the wide part down to the first plug B C, is filled with powdered cane sugar (No. 50, B.P. gauge), which has been carefully dried and sterilized at 120°-130° C. The tube is again sterilized at 120° to 130° for two or three hours, the greatest care being taken not to melt the sugar. After sterilization the tube is ready for use. The wool plug is removed from the mouth A, and a measured volume of air is aspirated through the layer of powdered sugar by

FIG. 73.

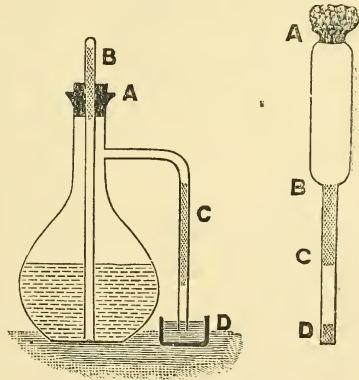

The wool plug is removed from the mouth A, and a measured volume of air is aspirated through the layer of powdered sugar by

\* Lancet, July 14, 1894, p. 74 (1 fig.).



means of a small hand air-pump, the volume of air being measured by the displacement of water in a flask. Having taken the sample (5-20 litres), the wool plug is replaced in the neck A. The powdered sugar is then shaken down into the wide part of the tube A B, and 15 ccm. of melted sterile nutrient gelatin are poured in. The powdered sugar readily dissolves in the melted gelatin, and when solution is complete a roll-culture is made in the tube, just as in Esmarch's method. The tube is then placed in an incubator at 20° C., and the colonies are allowed to develop.

**Cultivation of Tetanus Bacillus.\***—Dr. R. T. Hewlett cultivates tetanus bacillus in yeast flasks of about 90 ccm. capacity, three parts filled with 2 per cent. grape sugar bouillon. The neck is plugged with a perforated rubber stopper through which a glass tube passes to the bottom of the flask. The upper end of this, and the side tube also, are stuffed with cotton wool. The apparatus is first sterilized and then inoculated. After this the vertical tube is connected with a hydrogen generating apparatus, and when the whole flask is filled, the end of the side tube is plunged in a vessel filled with mercury, and the free end of the vertical tube sealed off in the blowpipe flame.

**Cultivating Anaerobes in Agar.†**—Dr. R. T. Hewlett cultivates anaerobes in narrow test-tubes, three parts filled with 2 per cent. sugar-agar. The tubes are steamed for a few minutes in a sterilizer to get rid of dissolved oxygen, and then cooled in water. When the agar has set, the inoculations are made well into the depth of the medium. The inoculation puncture is then sealed up by heating the tube in a flame, so as to melt the superficial layer of the agar. The upper part of the tube is heated, and a well-fitting rubber cap applied while the tube is still hot.

**Heating Arrangement of the Microscope for Bacteriological Purposes.‡**—Herr P. Friedrich describes a new heating arrangement for the Microscope. An air-bath, in which the Microscope stands, is the chief feature of the arrangement. This air-bath is closed in front by a glass plate, and is kept at a temperature of 37° by a water-jacket, heated from below. The temperature is regulated by means of a Meyer-Reichert regulator.

## (2) Preparing Objects.

**Simple Method for Producing two or more Embryos from one Egg.§**—Herr J. Loeb experimented with eggs of *Arbacia* which were artificially fertilized in normal sea-water. Ten minutes after fertilization they were removed to sea-water and distilled water in equal volumes; the membrane was destroyed by endosmosis, and part of the protoplasm escaped. The egg now consisted of two connected spheres of protoplasm which contained one nucleus between them. If, after some time, the eggs were returned to normal sea-water, each of the two spheres developed into a completely normal and perfect embryo. His experiments show that an embryo can arise simultaneously from each part of

\* Lancet, July 14, 1894, p. 73 (1 fig.).

† P. cit.

‡ Internat. Med.-photogr. Monatschrift, i. (1894) p. 30. See Arb. d. Kais. Gesundheitsamtes, viii. (1892).

§ Arch. f. ges. Physiol., lv. (1894) pp. 525-30. See Zool. Centralbl., i. (1894) p. 346.



the protoplasm, and of the nucleus, if these parts are isolated to a certain extent, and can assume a spherical or ellipsoidal form.

**Newt Ova.\***—Prof. G. Born gives a full account of his methods. For the larger ova he used chromacetic acid, and that plus sublimate; the smaller ova he placed in hot 1/3 per cent. chromic acid solution (80°–90° C.) which fixed the ova instantaneously; the solution was allowed to cool, and the objects were left in it for two days. Strasser's collodium-castor-oil mixture is most effective for fixing the sections on the slide. Böhmer's hæmatoxylin is the sovereign stain for these objects.

**Study of Living Fish-Embryos.†**—Mr. C. Hill twisted a piece of fine copper wire into a loop, the diameter of which was a little less than that of the yolk-sac of the embryo. The ends of the wire were then bent in such a way that they formed a support for the loop, of such a length that, when placed in a flat dish filled with water, the loop was raised 1 or 2 mm. from the bottom of the dish. The embryo was taken into a wide-mouthed pipette, held in a vertical position, and forced into the loop tail foremost in such a way that the loop, by constricting the yolk-sac, held the embryo firmly in position. By bending the wire supporting the loop, the embryo could be brought into any desired position.

**Examination of Nervous System of *Myxine glutinosa*.‡**—Mr. A. Sanders found it very difficult to make the nervous tissue hard enough to be sectioned; a year in bichromate of potash was not too long, and Erlicki's fluid had to be used to get it hard enough to make fairly fine sections. Soluble blue was found to show as much, if not more than, any other stain.

**Embryology of *Gebia littoralis*.§**—Mr. P. Butschinsky fixed the ova of this Crustacean with Perenyi's and Kleinenberg's fluid, or with alcoholic sublimate. Borax-carminé, hæmatoxylin, and hæmatein-alum were the best staining reagents. Embryos saturated with photoxylin were imbedded in a mixture of chloroform and paraffin at 40°–45°, and then in pure paraffin.

**Examination of Starfishes.||**—Mr. H. C. Chadwick has given up the use of osmic acid, as it penetrates slowly and makes the tissues brittle. In nearly every case he fixed his specimens with saturated solution of corrosive sublimate, taking care to expose well the parts required for sectioning. Decalcification was effected by immersion in 10 per cent. nitric acid for about a day. If a living starfish, after the separation of the rays from the disc, be put into nitric acid solution and afterwards hardened with alcohol, there will be but little contraction.

**Preserving Larvæ of *Balanoglossus*.¶**—Mr. T. H. Morgan found that the only method that gave satisfactory results was to put the larvæ for a few minutes into an extremely dilute solution of lactic acid; they

\* Arch. f. Mikr. Anat., xliii. (1894) pp. 1–79 (4 pls.).

† Journ. Morphol., ix. (1894) p. 238.

‡ 'Researches in the Nervous System of *Myxine glutinosa*,' London, 4to, 1894, p. 3.

§ Zool. Anzeig., xvii. (1894) p. 353.

|| Trans. Liverpool Biol. Soc., vii. (1893) p. 232.

¶ Journal of Morphology, ix. (1894) p. 6.

were then hardened in picrosulphuric acid or picrosalt solution; the dead and hardened worms retained the shape of the living worm almost perfectly. Lactic acid acts too slowly on adults to be of use for them.

**Study of Endoglobular Parasites.\***—M. A. Labbé prepared a convenient staining reagent by putting on the slide a drop of methylen-blue 1 part, water 100 parts, and chloride of sodium 0.75, which was drawn under the cover-glass by blotting-paper. One per cent. solutions of acetic carmine and of methylen-green also gave good results. For fixing *Gymnosporidia* the following method was used:—Flemming's fluid, then five minutes in distilled water; after drying, a solution of one drop of acetic acid in 20 ccm. water; then in picric solution (picric acid, 30 parts of concentrated aqueous solution, 30 parts distilled water, and 1 part glacial acetic acid); after being in this for a day, the preparation was washed in absolute alcohol.

Various staining reagents were used; a triple coloration was effected with Delafield's hæmatoxylin, acid fuchsin or Bengal rose, and aurantia; several methods of staining must be tried to find the key to the structure of these organisms.

**Botanical Microtechnique.†**—Herr F. Rosen after pointing out that the contraction of vegetable tissue during imbedding is by the ordinary method often unavoidable, advises the following procedure. The objects, thoroughly dehydrated in absolute alcohol, are successively transferred (1) to a mixture of equal parts of absolute alcohol and bergamot oil; (2) to pure bergamot oil; (3) to a mixture of equal parts of bergamot oil and paraffin; (4) to paraffin with melting-point 45°; (5) to paraffin with melting-point 56°–58° for 24 hours. In stages (3) and (4) the fluids should be kept at 48°, in stage (5) at 60°. In order to make the sections adhere to the slide they are placed while still in paraffin on a drop of fluid which can be evaporated completely. The fluids suitable for this purpose are distilled water or 50 per cent. pure alcohol. Evaporation at room temperature is slow, but can be rapidly and safely accomplished at 32°–36°. When the fluid has completely evaporated the section adheres firmly and there is no damage to the finer structures. The paraffin is then dissolved out with xylol. The three temperatures 32°–36°, 45° and 60° are obtained in a tripartite paraffin oven devised by the author. In this apparatus sections 5–10  $\mu$  thick are made to adhere in about 12 hours. Of course the alcohol must be completely evaporated before the sections are treated with xylol, otherwise they will get free.

**Preparing Megaspore and Female Prothallium of Selaginella.‡**—The great delicacy of these objects makes imbedding difficult. As a fixing process Herr E. Heinsen recommends the action, for ten minutes, of a mixture of 1 gr. chromic acid, 0.4 gr. osmic acid, and 0.4 gr. acetic acid in 200 gr. water; or a three minutes' treatment with a 1 per cent. solution of sublimate. The collapsing of the protoplasm of the spore was avoided by this method.

\* Arch. Zool. expér. et gen., ii. (1894) pp. 57–61.

† Schlesische Gesellsch. f. Vaterland. Cultur, Jahresbericht, 1893 (Bot. Sec.) pp. 8–11.

‡ Flora, lxxviii. (1894) pp. 468–9.

FIG. 74.

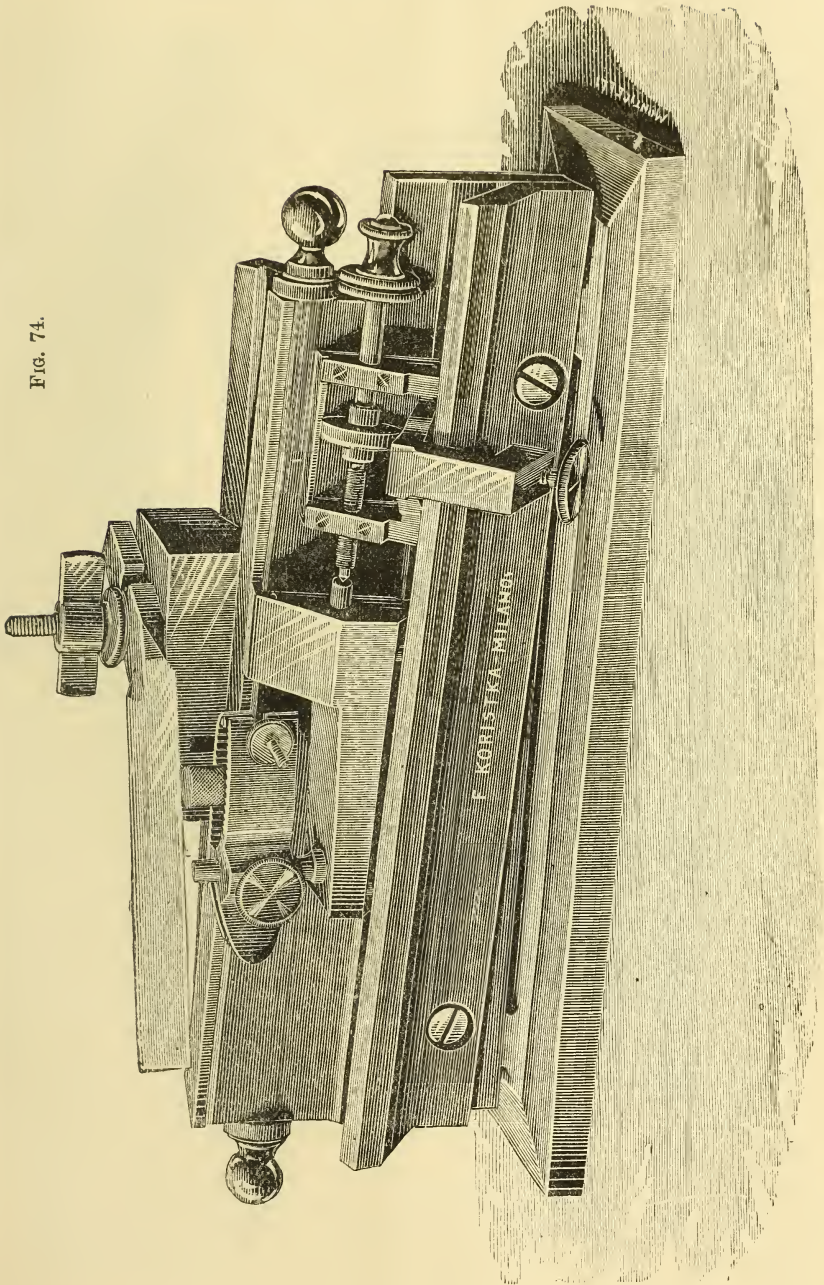



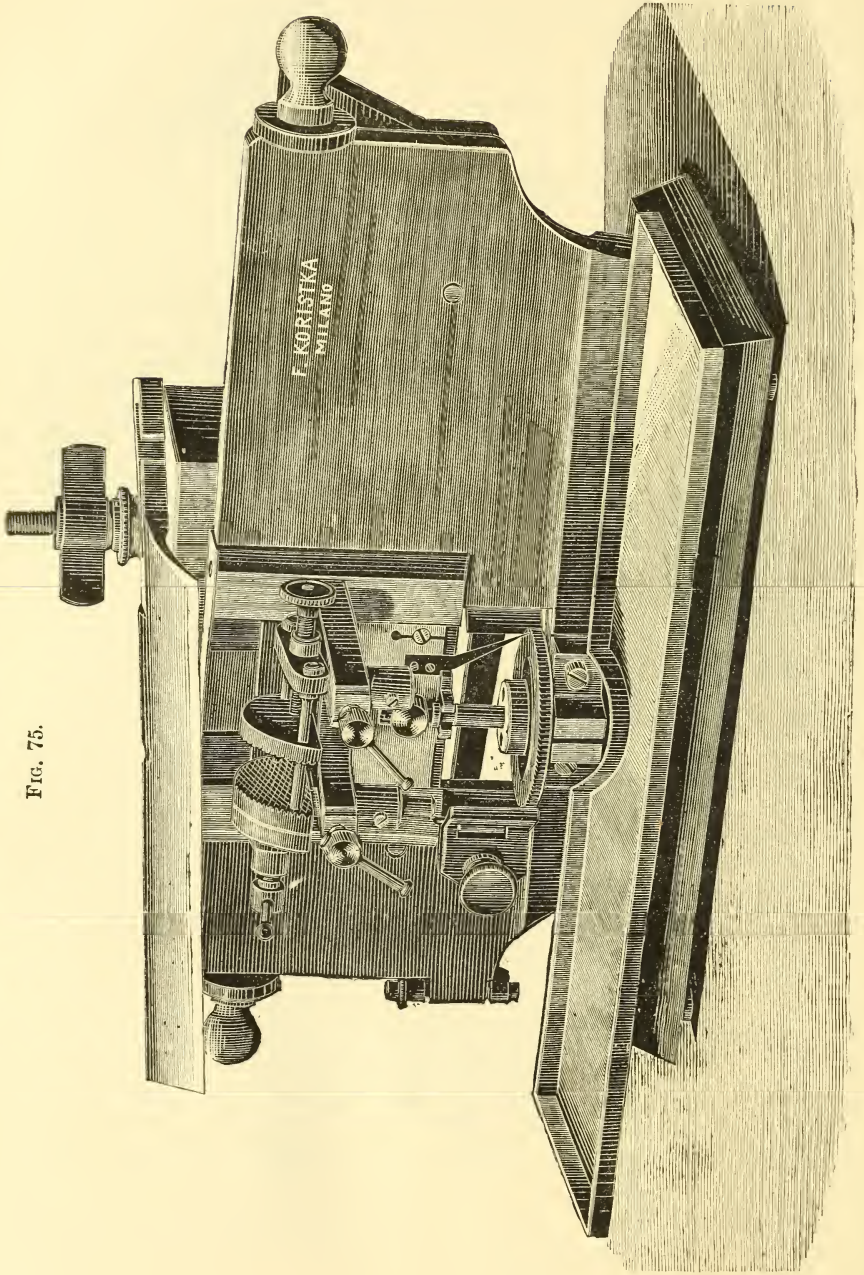

FIG. 75.



## (3) Cutting, including Imbedding and Microtomes.

**Koristka's Microtomes.\***—The instrument with double slide represented in fig. 74 is of cast iron nickeled. The razor runs on a horizontal slide-way, and the object-holder on a slide inclined at  $1/20$ . The motion of the object-holder is by means of a micrometer screw with a divided head, which allows of the measurement of displacement of the object to be sectioned of  $1/1000$  mm. The micrometer screw can be displaced along the slide. The length of the slides is 26 cm.

FIG. 76.

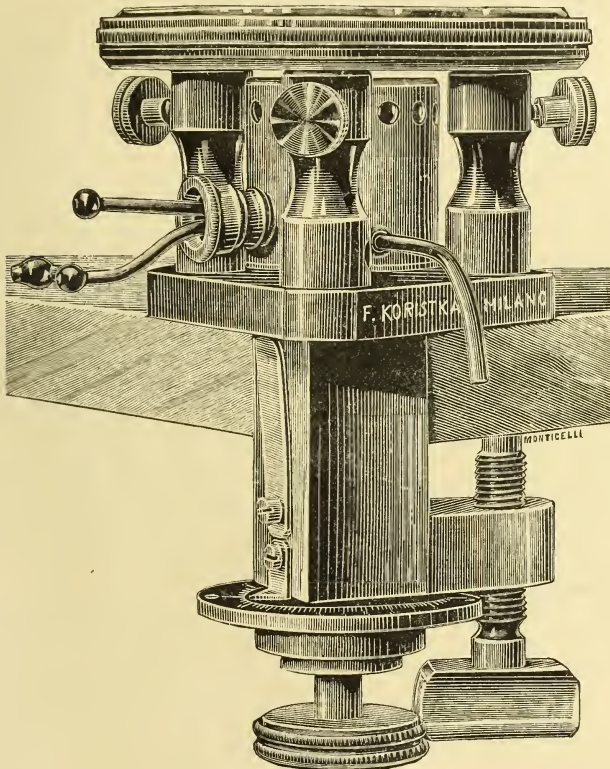

The automatic microtome shown in fig. 75 has a stand of cast iron nickeled interiorly. The slide has a length of 25 cm., with a free course of the knife of 17 cm. The raising of the object is effected automatically by means of a micrometer screw and an escapement. The thinness of the sections can be regulated by a screw from 0.005 to 0.03 mm. The slide on which the knife is fixed rests on five points of tempered steel and moves with very slight friction.

The freezing microtome (fig. 76) is of new construction. By means

\* F. Koristka, *Catalogo Illustrato Descrittivo*, N. 7, Milan, 1894.

of a screw-clamp it can be fixed to any table having a projecting edge. The glass plate allows of cutting in any direction. It can be readily removed for cleaning, and replaced by a hollow cylinder for sectioning by the ordinary methods of imbedding. The screw for the displacement of the preparation has a disc divided in hundredths of a millimetre and is provided with a catch which marks each displacement of a division. For the sectioning the razor is moved by hand.

**Large Microtome for Brain-sections.\***—Dr. J. Pal describes a new microtome made by C. Reichert according to his design, with which he has succeeded in easily obtaining sections of both hemispheres of the human brain.

The instrument (fig. 77) is mainly constructed on the same principle as that described in *Zeitsch. f. wiss. Mikr.*, i. (1884) p. 241, but differs from it by special arrangements which allow of sections being made through a whole brain under water. It is also double the size and of stronger make. The length of the slide is 50 cm., so that knives with a cutting edge of 36 to 38 cm. can be used. Objects with a diameter of from 12 to 13 cm. and a height of 10 cm. have been cut with the instrument. For cutting under water the tank W is provided; the deep central portion of this is formed of a stout leather bag V. At the bottom of this bag there is a box through which the rod of the clamp passes. The tank can be emptied by means of the cocks *vv'* at both ends. The rod of the clamp is received by the clamp-holder, which is adjustable in all directions. The holder is connected with a very strong slide which is raised by a micrometer screw having a diameter of about 18 mm. and pitch of 0.6 mm. By this screw the object can be raised 15 mm., and consequently from 250 to 300 sections may be cut in a continuous series without further adjustment of the object.

As soon as the micrometer screw has reached its highest position, the pawl *sp* (fig. 78) and the spiral spring at the back of the microtome are disengaged, the micrometer screw is screwed down, the object-carriage pressed outwards, and the object again raised up to the knife-edge, so that the operator can resume cutting without change of the plane of the sections.

On the back stroke of the knife, the object is automatically raised by a certain amount within the limits of 0.005 mm. and 0.055 mm. To obtain thicker sections the automatic arrangement must be set in motion twice, when sections of a thickness up to 0.11 mm. may be cut.

The knife-carriage, which is of specially heavy construction and slides on five points as in Reichert's smaller microtomes, has, to prevent tilting, a double groove, and is pressed on the slide by a spring counter-plate.

For moving the slide the driving belt arrangement seen in fig. 78 is chosen. The crank shown in fig. 77 has been lately replaced by a fly-wheel (fig. 78).

The knife is attached to the knife-carrier T (fig. 77) by the two screws *s* and *s'*, and is fixed by the nut *m*. It is prevented from springing by the support *st*. The microtome can be used without the tank, as seen in fig. 78.

\* *Zeitschr. f. wiss. Mikr.*, x. (1893) pp. 300-4.

FIG. 77.

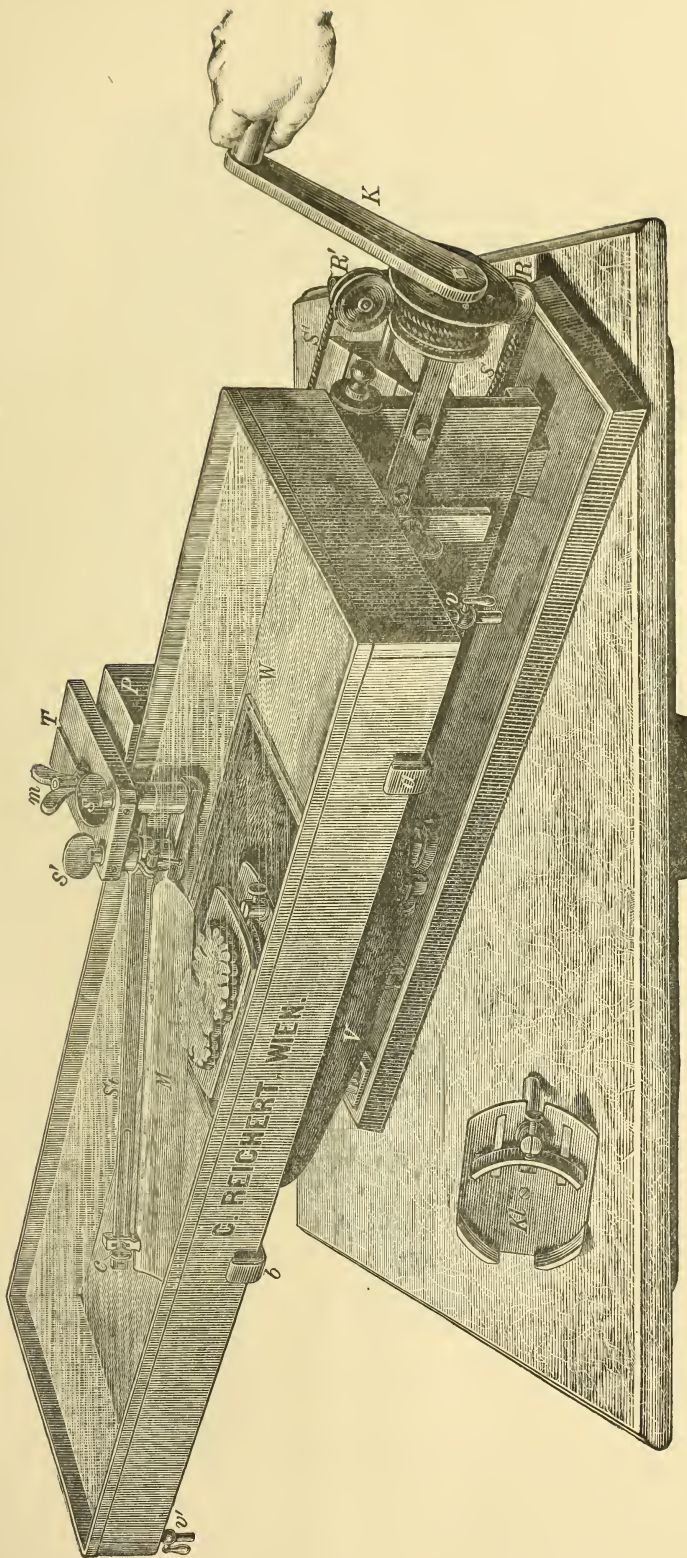
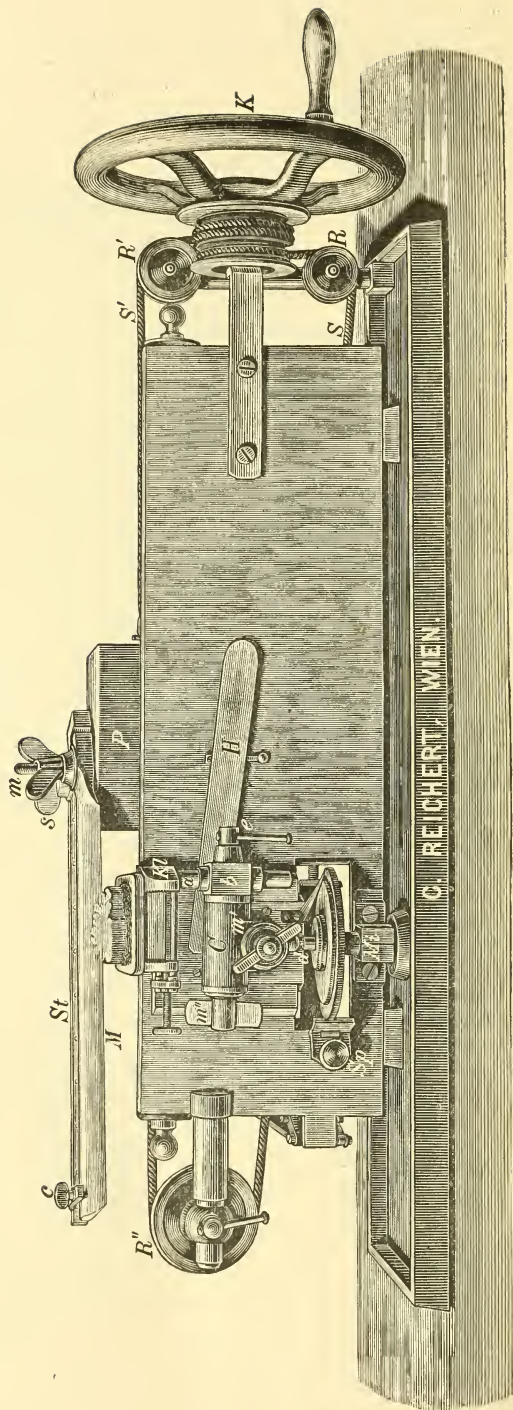



FIG. 78.





In the treatment of the brains and sections the author uses the following process:—After previous injection with Müller's liquid, to which one-quarter of its volume of a 5 per cent. solution of lysol has been added, the brain is hardened and kept in a dark cupboard at the ordinary temperature of the room. Hardening in the hatching oven is to be avoided.

The pieces are dried with blotting-paper, and *without* washing are, after a short stay in absolute alcohol, immersed in photoxylin. They are then glued to a metal plate which is attached to a smaller piece of wood fitting into the object-clamp. The use of a metal plate is indispensable, as wooden plates would warp in consequence of the prolonged immersion in the bath.

In the sectioning, the sections sink in the water and are caught on a sheet of paper with the help of a fine brush.

For staining the sections the author has resorted to the principle described by Oregia,\* which consists in bringing the section on to a glass plate coated with a mixture of candied sugar and dextrin. The section adheres to the layer of sugar and the paper can be removed. The preparation is then dried with fine blotting-paper and afterwards covered with a thin layer of photoxylin, which on drying is pressed against the section by means of a roller. The plate is then placed in water, when the sugar dissolves, setting free the section with its adhering photoxylin backing; such sections can then be easily stained with hæmatoxylin, since they can be passed through the various liquids without injury.

**Quick Double-staining Method for Examination of Blood and Tissues.**†—Dr. Inghilleri's method of double-staining depends on the mordant and fixative properties possessed by absolute alcohol, ether, and chloroform. The preparations are to remain for just 30 minutes in any of these fluids, but not longer, otherwise their sensitiveness to staining reagents is diminished. The procedure is as follows:—The cover-glass or section is first placed in chloroform for 30 minutes, and then in a mixture of 40 parts 1 per cent. eosin in 70° alcohol and 60 parts of a saturated aqueous solution of methylen-blue. The solution should be warmed for 2 or 3 minutes.

The method is very suitable for the study of phagocytosis and of malaria parasites.

**Demonstrating Nucleated Red Corpuscles.**‡—M. Timofeyewski has found that by injecting a solution of sodium chloride into animals large numbers of nucleated red corpuscles appear in the blood soon after the injection. These nucleated globules are about the same size as the ordinary red corpuscle, but they contain a round, well-defined nucleus 4–5  $\mu$  in diameter, often placed excentrically. When stained by the Ehrlich mixture they are either black or assume a blue or greenish hue. The investing membrane of the nucleus is always quite distinct. Sometimes the nuclei are freed and devoid of protoplasm.

The solution injected consisted of sodium chloride exposed to the air

\* See Neurol. Centralbl., 1890.

† Centralbl. f. Bakteriol. u. Parasitenk., xv. (1894) pp. 820–1.

‡ Wratsch, 1894, No. 2. See Ann. de Micrographie, vi. (1894) pp84–6.

and allowed to putrefy for 30 days. It was then filtered and sterilized twice over, and kept in hermetically sealed tubes. When required for injection it was heated to 31°-38°, 10-11 ccm. per kilogram being injected into the saphenous or femoral vein. The blood examined was obtained from an artery in the ear.

**Staining Tubercle Bacilli.\***—M. Letulle advises the following procedure for staining tubercle bacilli under any condition of tissue or fixation method:—The preparations are to be immersed for 1 to 24 hours in carbol-rubin and then transferred to a 1½ per cent. solution of permanganate of potash. This is followed by immersion in a saturated aqueous freshly prepared solution of sulphurous acid. The preparations must then be washed freely in water, after which they may, if so desired, be double-stained by means of a saturated aqueous solution of methyl-blue. The sections should then be washed until they are almost decolorized, after which they are dehydrated in alcohol, passed through xylol, and mounted in balsam.

**Staining Flagella of Bacteria.†**—Dr. R. Bunge uses as a mordant a mixture of aqueous solution of tannin and liquor ferri sesquichlor., the latter with water in the proportion of 1 to 20 aq. dest. Three parts of the tannin solution and one part of the dilute iron solution are then mixed, and to 10 ccm. of the mixture 1 ccm. of a saturated aqueous solution of fuchsin is added. The mordant is not to be used fresh, for it works better after having been exposed to the air for some days or weeks. The author obtained good results without any addition of acid or alkali with *Proteus*, *Bact. coli*, typhus, and cholera. After carefully fixing the film on the cover glass, the filtered mordant and the preparation are to be kept in contact for about five minutes. The preparation is then washed, dried, and stained with phenol-fuchsin in the usual way.

**Demonstration of Influenza Bacillus.‡**—Dr. M. Borchardt found Pfeiffer's influenza bacillus in thirty-five out of fifty cases examined. In order to be successful Pfeiffer's directions must be strictly observed. The sputum must be quite fresh and the lump washed in a sterile water. Cover-glass preparations are then made from the centre of the mass and stained with dilute Ziehl's fuchsin (1-10 or 20) after which they are washed in water or decolorized in dilute acetic acid. Sometimes the preparations show other bacteria as well as influenza bacilli, sometimes the latter are impure cultivations. The bacilli should be fairly evenly distributed over the field; they are usually free, though sometimes inside cells or, when mixed with mucous flakes, in little clumps or swarms.

The influenza bacilli may be demonstrated in the sputum for at least a week. Microscopical examination is not always sufficient for the recognition of the bacilli, for the staining differences are sometimes considerable, especially when from polar staining they resemble diplococci. Even cultivation is sometimes unsatisfactory. For this purpose a washed sputum mass is immersed in bouillon, and when thoroughly

\* Bull. Soc. Belge de Microscopie, xx. (1893-4) pp. 184-5.

† Fortschritte d. Med., xii. (1894) No. 12. Centralbl. f. Bakteriol. u. Parasitenk., xvi. (1894) p. 217.

‡ Berlin Klin. Wochenschr., 1894, No. 2. See Centralbl. f. Bakteriol. u. Parasitenk., xvi. (1894) pp. 78-9.

disseminated is inoculated on oblique agar which has been treated with blood, or the agar may be inoculated directly. In the first case colonies appear in 24 hours, in the latter in 12–15 hours, though these are often mixed with other bacteria. The author also cultivated on agar plates mixed with a few loopfuls of human or rabbit's blood. On such plates the small homogeneous structureless influenza colonies are easily distinguishable from other bacterial growths.

**Natural Injection.\*** — Dr. E. Retterer has a note on Herr K. Zellner's † method of "natural injection," which is similar to one which he has himself used. ‡ Portions of a body whose blood has been retained are cut into fragments about 3 cm. in diameter, placed in Müller's fluid for at least 24 hours, washed for 2 hours in a current of water, gradually saturated with alcohol, cut in paraffin, stained for 24 hours in Biondi-Heidenhain's mixture, washed and dehydrated as usual. Then it is seen that the red blood-corpuscles have a golden yellow colour, which beautifully marks the course of the blood-vessels.

(5) Mounting, including Slides, Preservative Fluids, &c.

**Method for Mounting Opaque Objects.** — At the meeting of the Society in June last Mr. J. J. Harvey read the following note on his method of mounting opaque objects, which allows of the object being rotated when examined under the Microscope.

"One of the many objections to the present system of mounting opaque objects is that it is necessary to permanently hide one side of the specimen, and in the case of aberrant or rare forms this may greatly lessen the value and interest of the slide. The method here advocated allows of the revolution of the object under the Microscope, and permits

Fig. 79.

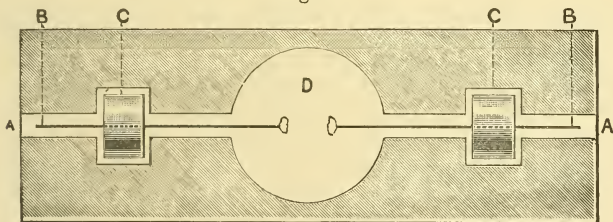

of its examination with as much ease as a hand specimen. It is at the same time as permanent and as compact as the older system. Another important advantage is the differential lighting which this rotation brings into play, and which the inventor has found of special service in the study of the Foraminifera for which this method was originally designed. The slides used are the wooden slips recommended for this class of objects by Carpenter and others. The specimen is attached by means of a suitable medium to the end of a needle (fig. 79, B) which has been thrust through the centre of a plug of india-rubber cord C.

\* Journ. de l'Anat. et de la Physiol., xxx. (1894) p. 336.

† Archiv f. Pathol. Anat. u. Physiol., cxxxv. p. 147.

‡ Journ. de l'Anat. et de la Physiol., 1888, p. 324.



This is laid, with the specimen projecting into the central cell D, in a shallow longitudinal groove A cut just deep enough to enable the specimen to revolve without touching the cover-glass, a hole having also been cut for the reception of the rubber plug. The projection of this plug above the surface allows the whole arrangement to revolve by the mere movement of the finger. When the cover-glass has been placed in position the whole can be finished off with paper in the usual way. A neater appearance is obtained by mounting two specimens in each slip, one on either side of the cell."

**Cleaning Cover-glasses.\***—Herr E. Funck says that cover-glasses are most advantageously cleaned by uniting chemical and mechanical action. The dirty cover-glasses are soaked for some time in turpentine oil and then removed to a vessel containing some 30 ccm. of hydrochloric acid to which two or three pinches of potassium chlorate have been added. They are then heated in a water-bath until all colour has disappeared. The glasses are then washed with hot water and next placed in a mixture of equal parts of powdered soda, talc, and fine sawdust made into a thick soft paste with water. The mixture and the glasses are then heated for half an hour in a water-bath. After this the cover-glasses are again washed with hot water, to which a few centimetres of weak hydrochloric or acetic acid have been added. Lastly the glasses are washed with hot water or ether alcohol and dried with a soft cloth. They are now perfectly clean, and there is no necessity for heating them on the iron plate.

**Uses of Formaldehyd.†**—Herr F. Cohn's experiments with formaldehyd are confirmatory of previous observations showing that in weak aqueous solution and in vapour it kills bacteria, both in the vegetative and spore conditions. Hence it is extremely useful for sterilizing, disinfecting, &c., and is suitable for the preservation of preparations. Against mould fungi its action is not invariable, and requires occasionally to be used in somewhat large quantity.

**Changes caused in Nervous Tissue by Hardening Reagents.‡**—Prof. H. H. Donaldson has made a number of experiments and observations with the object of determining what changes are induced by the hardening reagents generally employed. He finds that a sheep's brain under the influence of solutions of bichromate of potash increases in weight and volume; this is due to the taking up of the solution, and it is made greater by freshness, absence of pressure, and low percentage of salts in the solution; it is made less by a temperature of 38°. The general action of alcohol is to decrease the weight and volume of the sheep's brain, and the higher the percentage of alcohol the more rapid and great is the loss in weight; this loss is due to the decrease in the volume of the specimen by shrinkage, extraction of solids, and replacement of water by the alcohol of a less specific gravity.

Alcohol of 50 per cent., a saturated solution of sodium chloride, or a mixture of bichromate of potash and alcohol disturb the normal weight but slightly.

\* *Centralbl. f. Bakteriol. u. Parasitenk.*, xvi. (1894) pp. 113-4.

† *Jahresbericht d. Schles. Gesellsch. f. Vaterl. Cultur*, ii. Abth. Bot. Section, (1893) pp. 23-31.

‡ *Journal of Morphology*, ix. (1894) pp. 123-66.



**Collecting and Preserving Urinary Sediment.**—Dr. Bohland\* first collects casts, cells, and other solid particles occurring in urine by sedimentation or by centrifuging. The deposit is washed with saline solution and then treated with Müller's fluid renewed every three or four days for a fortnight, after which it is hardened with absolute alcohol. Epithelium, leucocytes, and casts are readily recognizable. The sediment may also be stained by placing a drop of the deposit in alcohol on a cover-glass and evaporating slowly so as to get a thin film and then colouring this with Ehrlich's neutrophile mixture. Specimens prepared in this way last for a few weeks.

Dr. T. Harris † pipettes off some of the deposit from the bottom of an ordinary conical urine glass (1–2 cm.) and then places this in a sort of test-tube containing a preservative fluid composed of potassium acetate

FIG. 80.

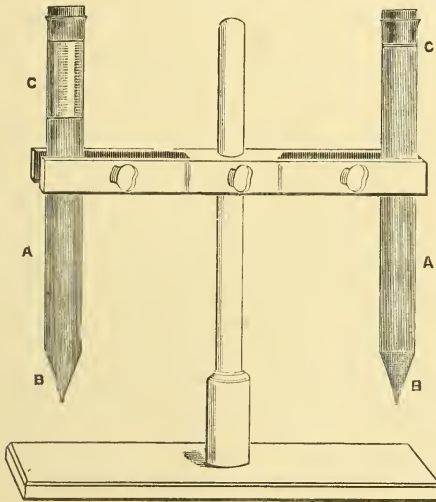

60 gm., chloroform 10 cm.,  $H_2O$  1000 cm. The tube is a piece of ordinary glass tubing about  $5/8$  in. diam., and drawn out to a point so that the lower opening is about  $1/8$  in. diam., the length being about 13 in. and the capacity about 60 cm. The upper end is closed by a rubber plug  $1\frac{1}{4}$  in. long.

The tube is to be filled with preservative fluid to within an inch of the top, and while doing this the lower aperture should be stopped with the finger. When the sediment has subsided, a sufficient quantity may be obtained by holding a slide underneath and just pressing on the rubber plug above.

Dr. B. Bramwell ‡ proceeds by mixing equal quantities of urine and aqueous solution of boracic acid. The deposit is pipetted off into a

\* Centralbl. f. wiss. Med., May 19, 1894, pp. 449–51.

† Brit. Med. Journ., June 23, 1894, p. 1356 (1 fig.).

‡ Op. cit., July 7, 1894, p. 8.

solution of picrocarmine, and after having been allowed to stain for 24 hours or so is examined. In case of suspected amyloid disease methyl-violet may be used instead of picrocarmine. Permanent preparations may be made by mixing the stained deposit with Farrant's medium and allowing the mixture to stand for three or four days, and then mounting a specimen from the deposit.

(6) Miscellaneous.

**Microchemical Reaction of Vegetable Albumen.\***—Dr. A. De Wèvre studied the microchemical reactions of vegetable proteids in specimens rich in reserve-albumen, such as the pea, castor-oil plant, maize, and wheat; also in *Cucurbita pepo*, *Carica Cundinamarcensis*, and some other plants. The reagents in their action are considered under three divisions—coagulating, precipitating, and colouring. The author arrives at the following conclusions:—

(1) Albuminoids cannot be localized by means of a single reagent; several are needed.

(2) Before testing, sections must be boiled in water, then in absolute alcohol, or be immersed in tartaric acid alcohol.

(3) The most sensitive reagents are, in order of sensitiveness:—*a.* Iodopotassic iodide, or a solution of eosin. *b.* Millon's reagent. *c.* Picric acid, xanthoproteic acid, phosphomolybdic acid: Gueзда's test (saturated ammoniacal solution of sulphate of nickel gives blue colour turning to orange-yellow with  $\text{KHO}$ ). *d.* Pietrowski's test (biuret reaction). *e.* Reichel and Mikosch's test (alcoholic solution of benzaldehyde plus  $\text{H}_2\text{SO}_4$ , containing a trace of ferric sulphate). If all the tests give a reaction, the presence of albumen is assured.

(4) Absolute alcohol is the best coagulating reagent.

(5) The xanthoproteic reaction answers best for the examination of porous tissue, "tubes criblés," &c., and the same may be said for eosin.

(6) The reactions from porous tissue are frequently not very marked.

(7) At the growing ends of roots and in the laticiferous vessels of various plants is a great quantity of proteid substances.

\* Bull. Soc. Belge de Microscopie, xx. (1893-94) pp. 91-121.

JOURNAL  
OF THE  
ROYAL MICROSCOPICAL SOCIETY.

DECEMBER 1894.

TRANSACTIONS OF THE SOCIETY.

IX.—*The Foraminifera of the Gault of Folkestone.*—VII.

By FREDERICK CHAPMAN, F.R.M.S.

(Read 17th October, 1894.)

PLATES IX. AND X.

*Sub-family NODOSARIINÆ—continued.*

CRISTELLARIA Lamarck [1816].

*Cristellaria linearis* Reuss, plate IX. fig. 1 *a, b.*

*C. linearis* Reuss, 1862, Sitzungsber. d. k. Ak. Wiss. Wien, vol. xlvi. p. 66, plate xii. fig. 1 *a, b.*

This species has an elongate test, with a slightly incurved commencement; the chambers are rounded in front, and in the later growth well inflated. The back of the shell is somewhat compressed

EXPLANATION OF PLATES.

PLATE IX.

- Fig. 1 *a, b.*—*Cristellaria linearis* Reuss: *a*, lateral aspect; *b*, face of the last chamber.  $\times 45$ .  
 „ 2 *a, b.*—*C. striata* sp. nov.: *a*, lateral aspect; *b*, face of the last chamber.  $\times 60$ .  
 „ 3 *a, b.*—*C. exilis* Reuss: *a*, lateral aspect; *b*, face of the last chamber.  $\times 60$ .  
 „ 4 *a, b.*—*C. exilis* var. *crispata* nov.: *a*, lateral aspect; *b*, face of the last chamber.  $\times 60$ .  
 „ 5 *a, b.*—*C. parallela* Reuss: *a*, lateral aspect; *b*, face of the last chamber.  $\times 60$ .  
 „ 6 *a, b.*—*C. cymboides* d'Orbigny: *a*, lateral aspect; *b*, face of the last chamber.  $\times 30$ .  
 „ 7 *a, b.*—*C. humilis* Reuss: *a*, lateral aspect; *b*, face of the last chamber.  $\times 45$ .  
 „ 8 *a, b.*—*C. crepidula* Fichtel and Moll sp.: *a*, lateral aspect; *b*, front peripheral aspect.  $\times 30$ .  
 „ 9 *a, b.*—*C. Schloenbachi* Reuss: *a*, lateral aspect; *b*, face of the last chamber.  $\times 60$ .  
 „ 10.—*C. costulata* sp. nov.: lateral aspect.  $\times 60$ .  
 „ 11 *a, b.*—*C. gladius* Philippi sp.: *a*, lateral aspect; *b*, face of the last chamber.  $\times 30$ .

into a blunt keel; this character, together with the incipient spiral commencement, demonstrates its affinity with the *Cristellarians*.

*C. linearis* was found by Reuss in the "Speeton clay," of North Germany.

Found in the Gault at Folkestone in zone xi., 45 ft. from the top, rare; 40 ft., very rare.

*Cristellaria striata* sp. nov., plate IX. fig. 2 *a*, *b*.

Test elongate, slightly incurved; the first few chambers form an open spiral, but the shell soon becomes straight. The later chambers are well inflated, and their sutural lines strongly impressed. The larger of the specimens found has nine chambers. Surface of the test decorated with a few longitudinal or oblique striae. Aperture marginal and produced into a short neck. Length of the larger specimen  $1/45$  in.

This species was found in the Gault of Folkestone in zone iii., very rare; zone xi., 45 ft. from the top, very rare.

PLATE IX. (continued).

- Fig. 12 *a*, *b*.—*C. Bronni* Römer sp.: *a*, lateral aspect; *b*, face of the last chamber  
× 30.  
,, 13 *a*, *b*.—*C. Bronni* Römer sp.: (another specimen) *a*, lateral aspect; *b*, face of  
the last chamber. × 50.  
,, 14 *a*, *b*.—*C. lituola* Reuss: *a*, lateral aspect; *b*, front peripheral aspect. × 60.

PLATE X.

- Fig. 1.—*Cristellaria navicula* d'Orbigny: lateral aspect. × 60.  
,, 2 *a*, *b*.—*C. sulcifera* Reuss: *a*, lateral aspect; *b*, front peripheral aspect. × 60.  
,, 3 *a*, *b*.—*C. triangularis* d'Orbigny: *a*, lateral aspect; *b*, front peripheral aspect.  
× 60.  
,, 4 *a*, *b*.—*C. trunculata* Berthelin: *a*, lateral aspect; *b*, front peripheral aspect.  
× 60.  
,, 5 *a*, *b*.—*C. oligostegia* Reuss: *a*, lateral aspect; *b*, front peripheral aspect.  
× 60.  
,, 6 *a*, *b*.—*C. tripleura* Reuss: *a*, lateral aspect; *b*, front peripheral aspect. × 60.  
,, 7 *a*, *b*.—*C. scitula* Berthelin: *a*, lateral aspect; *b*, front peripheral aspect.  
× 45.  
,, 8 *a*, *b*.—*C. latifrons* Brady: *a*, lateral aspect; *b*, front peripheral aspect.  
× 30.  
,, 9 *a*, *b*.—*C. Bononiensis* Berthelin: *a*, lateral aspect; *b*, front aspect. × 60.  
,, 10 *a*, *b*.—*C. Italica* DeFrance sp.: *a*, lateral aspect; *b*, front peripheral aspect.  
× 60.  
,, 11 *a*, *b*.—*C. vestita* Berthelin: *a*, lateral aspect; *b*, front peripheral aspect.  
× 60.  
,, 12 *a*, *b*.—*C. complanata* Reuss: *a*, lateral aspect; *b*, front peripheral aspect.  
× 60.  
,, 13 *a*, *b*.—*C. Bradyana* sp. nov.: *a*, lateral aspect; *b*, front peripheral aspect.  
× 60.  
,, 14 *a*, *b*.—*C. planisecula* Reuss: *a*, lateral aspect; *b*, front peripheral aspect.  
× 60.



*Cristellaria exilis* Reuss, plate IX. fig. 3 *a, b*.

*C. exilis* Reuss, 1862, Sitzungsab. d. k. Ak. Wiss. Wien, vol. xlv. pp. 66 and 92, plate vi. fig. 19 *a, b*.

This species has been recorded from the Upper Hils formation near Brunswick (Reuss); and from the Gault of Folkestone (Reuss, and by Rupert Jones in Topley's 'Weald Memoir'). From the Gault of France (Berthelin).

In the specimen from Folkestone, here figured, the chambers are somewhat irregular, but the outline of the test is typical.

*C. exilis* was found at Folkestone in zone iv., very rare; zone xi., 35 ft. from the top, rare; 12 ft., very rare.

*Cristellaria exilis* var. *crispata* nov., plate IX. fig. 4 *a, b*.

Test elongate, arched; commencing in an open spiral, somewhat hook-shaped, formed by the first four chambers, which are compressed and low. The chambers rapidly increase in size and height, and the later ones are inflated. The younger half of the test is decorated with a few interrupted longitudinal or oblique striations, which towards the inner side of the test run on to the last segment. The outer or dorsal edge of the shell is compressed into a blunt keel. Inner edge with a sinuous outline. Aperture marginal and produced. Length of test 1/36 in.

Found in zone i., specimen *b*, one example.

*Cristellaria parallela* Reuss, plate IX. fig. 5 *a, b*.

*C. parallela* Reuss, 1862, Sitzungsab. d. k. Ak. Wiss. Wien, vol. xlv. p. 67, plate vii. figs. 1, 2.

Reuss records this species from the Upper Hils clay of North Germany. It has also been obtained from the Gault of France (Berthelin); and was lately found in the Bargate beds of Neocomian age, at Littleton in Surrey (author's MS.).

Found at Folkestone in zone iii., rare; zone v., very rare.

*Cristellaria cymboides* d'Orbigny, plate IX. fig. 6 *a, b*.

*C. cymboides* d'Orbigny, 1846, Foram. Foss. Vien., p. 85, plate iii. figs. 30, 31. *C. cymboides*, 1890, Burrows, Sherborn and Bailey, Journ. Roy. Micr. Soc., p. 560, plate xi. fig. 6.

The Gault specimens are strikingly similar to that figured from the Red Chalk of Speeton by Burrows, Sherborn and Bailey. *C. cymboides* has also been recorded from beds of Tertiary age in Austria (d'Orbigny) and Hungary (von Hantken).

Found in the Folkestone Gault in zone viii., very rare; zone xi., 12 ft. from the top, very rare.

*Cristellaria humilis* Reuss, plate IX. fig. 7 a, b.

*C. humilis* Reuss, 1862, Sitzungsab. d. k. Ak. Wiss. Wien, vol. xlvi. p. 65, plate vi. figs. 16, 17.

This species varies in the relative width of the test, but it is easily recognized by the gentle curving of the shell, the numerous chambers, and the shelly thickening of the sutural lines.

*C. humilis* was found by Reuss in various beds of the Hils formation in North Germany.

Found at Folkestone in zone i., specimen *b*, very rare; zone ii., specimen *b*, very rare; zone xi., 50 ft. from the top, rare.

*Cristellaria crepidula* Fichtel and Moll sp., plate IX. fig. 8 a, b.

*Nautilus crepidula* Fichtel and Moll, 1803, Test. Micr., p. 107, plate xix. figs. *g-i*. *Cristellaria crepidula* d'Orbigny, 1839, Foram. Cuba, p. 64, plate viii. figs. 17, 18. *C. lævigata* Reuss, 1862, Sitzungsab. d. k. Ak. Wiss. Wien, vol. xlvi. p. 92, plate xii. fig. 14. *C. Fittoni* Berthelin, 1880, Mém. Soc. géol. France, sér. 3, vol. i. No. 5, p. 49. *C. crepidula* Brady, 1884, Chall. Rep., vol. ix. p. 542, plate lxvii. figs. 17, 19, 20; plate lxviii. figs. 1, 2.

This species occurs in nearly all assemblages of Foraminifera from the Lias upwards. It was recorded by Reuss from the Gault of Folkestone under the name of *C. lævigata*. Reuss' name of *C. lævigata* was subsequently changed to *C. Fittoni* by M. Berthelin in his study of the French Gault, for the reason that the specific name *lævigata* had been previously used by d'Orbigny in 1826 for another type of *Cristellaria*. There is, however, no apparent cause for separating the Gault examples from the well-known species *C. crepidula*, for indeed, among the numerous varieties of *Cristellariæ* bearing a general resemblance to the typical *C. crepidula* of Fichtel and Moll, this species here figured is the nearest, agreeing most minutely in all points with the type. *C. Fittoni* was recorded from the Gault of Monteley (Berthelin).

*C. crepidula* has also been recorded from the Red Chalk of Speeton by Burrows, Sherborn and Bailey.\* I am inclined to think, however, that their specimens more properly belong to *C. complanata* Reuss, since the sides of the tests are flat instead of gently convex as in the typical *C. crepidula*, and the commencing spiral more outspread.

*C. crepidula* has also occurred in the Neocomian beds of Littleton in Surrey (author's MS.). It was found in the Gault of Folkestone in zone i., specimen *b*, very rare; zone ii., specimen *a*, very rare; zone xi., 6 ft. from the top, rare.

\* Journ. Roy. Micr. Soc., 1890, p. 560, pl. ix. figs. 3, 4.

*Cristellaria Schloenbachi* Reuss, plate IX. fig. 9 *a, b*.

*C. Schloenbachi* Reuss, 1862, Sitzungsab. d. k. Ak. Wiss. Wien, vol. xlvi. p. 65, plate vi. figs. 14, 15. *C. Schloenbachi* Brady, 1884, Chall. Rep., vol. ix. p. 539, plate lxxvii. fig. 7.

Reuss describes this species from the Upper Hilsthon and the "Speeton clay" of North Germany, and it has also occurred in beds of Neocomian age at Littleton in Surrey (author's MS.). Dr. Brady has figured *C. Schloenbachi* as a recent form, and records it from deep-sea deposits of intertropical areas from depths of 155 to 435 fathoms.

Found at Folkestone in zone i., specimen *b*, rare; zone x., very rare; zone xi., 55 ft. from the top, very rare; 25 ft., very rare; 12 ft., very rare.

*Cristellaria costulata* sp. nov., plate IX. fig. 10.

Test elongate, commencing with a compressed incipient spiral; the chambers increase rapidly in size and become turgid. The surface of the test is relieved with more or less strong costulae, somewhat interrupted, and sometimes oblique. Aperture marginal and produced. The general outline of the test resembles that of *C. Schloenbachi* Reuss. Length of figured specimen, 1/42 in.

It is just possible that this form may be a *Cristellarian* modification of a species like *Marginulina Jonesi*, or another of the allied costate forms.

The original type specimen was unfortunately lost after the drawing was made.

*C. costulata* was found in zone v., very rare; zone ix., very rare.

*Cristellaria gladius* Philippi sp., plate IX. fig. 11, *a, b*.

*Marginulina gladius* Philippi, 1843, Beitr. z. Kenntniss d. Tertiärfl. nordwest. Deutschl., p. 40, plate i. fig. 37. *Cristellaria gladius* Hantken, 1875, Mitth. a. d. Jahrb. k. ungar. géol. Anstalt, p. 51, plate v. fig. 12.

Amongst the compressed arcuate forms of *Cristellaria* from the Gault there is one specimen which does not exactly correspond with any of the typical Cretaceous forms, but seems to be referable to the almost exclusively Tertiary species *C. gladius*. The Gault specimen also shows a decided thickening of the sutural lines, a character which is to be seen in typical examples of the species, but in this point it also bears some affinity to *C. humilis*.

*C. gladius* was found in zone v., very rare.

*Cristellaria Bronni* Römer sp., plate IX. fig. 12 *a, b*, fig. 13 *a, b*.

*Planularia Bronni* Römer, 1841, Verstein. d. nordd. Kreidegeb., p. 97, plate xv. fig. 14. *Cristellaria Bronni* Reuss, 1862, Sitzungsab. d. k. Ak. Wiss. Wien, vol. xlvi. p. 70, plate vii. fig. 13 *a, b*.

This species may be recognized by the compressed outer margin of the test, which is strongly keeled at the commencement. This feature serves to distinguish it from Reuss' *C. cephalotes*.\* Berthelin gives a figure of a Cristellarian of this elongate type,† along with another figure, both under the name of *C. trunculata*. The former figure is evidently a typical specimen of *C. cephalotes*; the latter figure,‡ however, being distinct from the other forms, is here treated as Berthelin's type of *C. trunculata*, and will be found noted subsequently in this series.

*C. Bronni* was described by Römer from the Hilsthon, and by Reuss from the "Speeton clay" of North Germany.

It was found in the Folkestone Gault in zone ii., specimen *b*, very rare; zone ii., specimen *c*, very rare; zone iv., very rare; zone v., very rare; zone vii., rare; zone x., frequent.

*Cristellaria lituola* Reuss, plate IX. fig. 14 *a, b*.

*Cristellaria lituola* Reuss, 1845, Verstein. böhm. Kreidef., pt. ii. p. 109, pl. xxiv. fig. 47.

This very distinct species was found in the Plänermergel of Bohemia by Reuss.

In the Gault of Folkestone it was found in zone i., specimen *b*, very rare; zone xi., 45 ft. from the top, very rare.

*Cristellaria navicula* d'Orbigny, plate X. fig. 1.

*Cristellaria navicula* d'Orbigny, 1840, Mém. Soc. géol. France, sér. i. vol. iv. p. 27, plate ii. figs. 19, 20. *C. navicula* Reuss, 1845, Verstein. böhm. Kreidef., pt. i. p. 34, plate xii. fig. 27.

This species is a familiar one in Cretaceous faunas. It has been recorded from the Gault of Montcley, France (Berthelin); the Plänermergel of Bohemia (Reuss); the Senonian-marl of Westphalia (Reuss); the Phosphatic Chalk of Taplow (Chapman); the Chalk of Sens and Meudon, France (d'Orbigny); the White Chalk of Kent (Rupert Jones in Morris's Cat. of Br. Foss.); the Upper Chalk of the North of Ireland (Wright); and from the Chalk of Maestricht (Reuss).

*C. navicula* was found in the Gault of Folkestone in zone iv., very rare; zone xi., 50 ft. from the top, very rare; 45 ft. very rare.

*Cristellaria sulcifera* Reuss, plate X. fig. 2 *a, b*.

*Cristellaria sulcifera* Reuss, 1862, Sitzungsb. d. k. Ak. Wiss. Wien, vol. xlvi. pp. 74, 93, pl. viii. figs. 8 *a, b*.

This species is distinguished from the allied forms of *C. navicula* and *C. Italica* by its grooved sutural lines. It was described by Reuss

\* Sitzungsb. d. k. Ak. Wiss. Wien, 1862, vol. xlvi. p. 67, pl. vii. figs. 5, 6.

† Mém. Soc. géol. France, 1880, sér. 3, vol. i. No. 5, p. 53, pl. iii. fig. 26 *a, b*.

‡ Tom. cit., p. 53, pl. iii. fig. 27 *a, b*.



from the *Minimus*-thou of Eilum in North Germany, and is also recorded by the same author from the Gault of Folkestone. *C. sulcifera* has also been found in the Neocomian beds of Littleton in Surrey (author's MS.)

Found at Folkestone in zone i., specimen *b*, frequent; zone iii., very rare; zone ix., rare; zone xi., 45 ft. from the top, very rare; 40 ft., very rare.

*Cristellaria triangularis* d'Orbigny, plate X. fig. 3 *a, b*.

*Cristellaria triangularis* d'Orbigny, 1840, Mém. Soc. géol. France, sér. i. vol. iv. p. 27, plate ii. figs. 21, 22. *C. triangularis* Reuss, 1845, Verstein. böhm. Kreidef., pt. i. p. 34, pl. viii. fig. 48.

This is also a distinctly Cretaceous form and has been recorded from the Gault of Folkestone (Rupert Jones in Morris's Cat. of Br. Foss., and also by Reuss); the Gault of Montcley (Berthelin); the "Chalk Detritus" of Charing, Kent (Rupert Jones); the Plänermergel of Bohemia (Reuss); the White Chalk of Kent (Rupert Jones); the Chalk of Sens (d'Orbigny); the Phosphatic Chalk of Taplow (Chapman); and from the Upper Chalk of the North of Ireland (Wright).

Found in the Gault of Folkestone in zone iv., very rare; zone v., very rare; zone viii., very rare; zone xi., 35 feet from the top, very rare; 6 ft., very rare.

*Cristellaria trunculata* Berthelin, plate X. fig. 4 *a, b*.

*Cristellaria trunculata* (pars), Berthelin, 1880, Mém. Soc. géol. France, sér. 3, vol. i., No. 5, p. 53, plate iii. fig. 27 *a, b*.

This species was described by Berthelin from the Gault of Montcley. It is closely allied to *C. oligostegia* Reuss. It differs from the latter form in the diminutive rolled commencement and greater compression and elongation of the test. The segments are usually much more numerous in *C. trunculata*; but both forms have the deeply indented sutures between the chambers, and the produced terminal orifice.

*C. trunculata* was found in the Gault of Folkestone in zone v., very rare; zone xi., 30 ft. from the top, very rare; 6 ft., very rare.

*Cristellaria oligostegia* Reuss, plate X. fig. 5 *a, b*.

*Cristellaria oligostegia* Reuss, 1860, Sitzungs. d. k. Ak. Wiss. Wien, vol. xl. p. 213, plate viii. fig. 8. *C. oligostegia* Reuss, 1862, Sitzungs. d. k. Ak. Wiss. Wien, vol. xlvi. p. 93, plate xiii. fig. 2.

Among the Gault *Cristellarix* which have few chambers and a well-rounded contour some individuals may be noticed which come within the description of Reuss' *C. oligostegia*, which was first found by that author in the detrital deposits of Westphalia, and subsequently in the Gault of Folkestone. It has since been found in the Neocomian beds of Chilworth, in Surrey (author's MS.)

It was found in the present series from Folkestone in zone ii., specimen *a*, very rare; zone ii., specimen *b*, rare; zone ii., specimen *c*, rare; zone iii., very rare; zone v., very rare; zone ix., very rare; zone xi., 55 ft. from the top, very rare; 40 ft., rare.

*Cristellaria tripleura* Reuss, pl. X. fig. 6, *a*, *b*.

*Cristellaria tripleura* Reuss, 1860, Sitzungsab. d. k. Ak. Wiss. Wien, vol. xl. p. 211, plate ix. fig. 5. *C. tripleura* Reuss, 1862, Sitzungsab. d. k. Ak. Wiss. Wien, vol. xlvi. p. 70.

The examples of *C. tripleura* from the Gault of Folkestone are very characteristic. Reuss described the species from the *Minimusthon* (the equivalent of the English Gault) of Westphalia.

It was found at Folkestone in zone i., specimen *b*, very rare; zone ii., specimen *c*, very rare.

*Cristellaria scitula* Berthelin, plate X. fig. 7 *a*, *b*.

*Cristellaria scitula* Berthelin, 1880, Mém. Soc. géol. France, sér. 3, vol. i. No. 5, p. 53, plate iii. fig. 3 *a-c*.

This species was described by Berthelin from the Gault of Monteley. The test of *C. scitula* is more elongate and compressed at the sides than *C. triangularis*, and the spiral commencement is inconspicuous.

*C. scitula* was found in the Folkestone Gault in zone xi., 6 ft. from the top, rare.

*Cristellaria latifrons*, plate X. fig. 8 *a*, *b*.

*Cristellaria latifrons* Brady, 1884, Chall. Rep., vol. ix. p. 544, plate lxxviii. fig. 19; plate cxliii. fig. 11 *a*, *b*.

The above species was described by Dr. Brady from recent specimens found off the West Coast of New Zealand, at 275 fathoms; and off Culebra Island, West Indies, at 390 fathoms.

The Gault specimen is fairly typical, although the latter chambers are not quite so erect as in the recent examples.

The only specimen of *C. latifrons* from the Gault was found in zone x.

*Cristellaria Bononiensis* Berthelin, plate X. fig. 9 *a*, *b*.

*Cristellaria Bononiensis* Berthelin, 1880, Mém. Soc. géol. France, sér. 3, vol. i. No. 5, p. 55, plate iii. fig. 23 *a-c*.

This species belongs to the type of *C. Italica*. It is a very constant form in the Gault, and was originally described by Berthelin from the Gault of Wissant and l'Aube.

In the specimens from Folkestone it is difficult in most cases to make out the secondary costulate ornamentation of the ventral or front aspect, such as is figured by Berthelin, but the strong median costula is always present.

*C. Bononiensis* was found in the Gault of Folkestone in zone ii., specimen *c*, very rare; zone iii., very common; zone iv., frequent; zone vi., very rare; zone ix., very rare; zone x., rare; zone xi., 55 ft. from the top, common; 50 ft., rare; 45 ft., frequent; 40 ft., very rare; 35 ft., common; 30 ft., very rare; 25 ft., frequent; 20 ft., rare; 12 ft., very rare.

*Cristellaria Italica* DeFrance sp., plate X. fig. 10. *a*, *b*.

*Saracenaria Italica* DeFrance, 1824, Dict. Sci. Nat., vol. xxxii, p. 177; vol. xlvii. p. 344.—Atlas Conch., plate xiii. fig. 6. *Cristellaria Italica* Parker, Jones and Brady, 1865, Ann. and Mag. Nat. Hist., ser. 3, vol. xvi. pp. 21, 32, plate i. figs. 41, 42. *C. Italica* Brady, 1884, Chall. Rep., vol. ix. p. 541, plate lxviii. figs. 17, 18, 20–23.

*C. Italica* as it appears to be generally accepted consists of an elongate test, triangular in transverse section, and with a small and open spiral commencement; the edges of the test are usually more or less rounded, but the specimens from the Gault bear some affinity towards *C. navicula* in that the edges are sharp, and the back distinctly keeled, but are separated from that form on account of the elongation of the test. As a recent form *C. Italica* is found in moderately shallow water, at depths from about 100 to 700 fathoms. It has been noted in the fossil condition from beds of Neocomian age at Littleton, in Surrey (author's MS.). It has also been recorded from the Chalk of the North of Ireland (Wright) and from various strata of Tertiary age.

*C. Italica* was found in the Folkestone Gault in zone i., specimen *b*, rare; zone ii., specimen *a*, very rare; zone iv., very rare; zone ix., very rare; zone x., very rare; zone xi., 20 ft. from the top, very rare; 12 ft., very rare.

*Cristellaria vestita* Berthelin, plate X. fig. 11 *a*, *b*.

*Cristellaria vestita* Berthelin, 1880, Mém. Soc. géol. France, sér. 3, vol. i. No. 5, p. 55, plate iii. fig. 22 *a*, *b*.

This pretty form is a fairly constant one in the Gault series from Folkestone. It was described by Berthelin from the Gault of Monteley, France, and it has also been found in strata of Neocomian age, viz. the Bargate-beds at Littleton in Surrey (author's MS.).

*C. vestita* was found at Folkestone in zone iii., very rare; zone v., very rare; zone vii., very rare; zone x., very rare; zone xi., 55 ft. from the top, frequent; 50 ft., frequent; 40 ft., frequent; 35 ft., rare; 30 ft., rare; 12 ft., very rare.

*Cristellaria complanata* Reuss, plate X. fig. 12 *a*, *b*.

*Cristellaria complanata* Reuss, 1845, Verstein. böhm. Kreidef., pt. i. p. 33, plate xiii. fig. 54. *C. complanata* Reuss, 1862, Sitzungsab. d. k. Ak. Wiss. Wien, vol. xlvi. p. 92, plate xii. fig. 13 *a*, *b*.

This species was described by Reuss from the Plänermergel of Bohemia, and he subsequently recorded it from the Gault of Folkestone. It has also been found in beds of Neocomian age at Littleton in Surrey (author's MS.).

*C. complanata* was found at Folkestone in zone xi., 12 ft. from the top, frequent; 6 ft., frequent.

*Cristellaria Bradyana* sp. n., plate X. fig. 13 *a, b*.

Test suboval, with nearly flat sides. It consists of about twelve narrow and gently arched chambers divided by sutural ridges which are interrupted towards the front of the shell, and nearer the dorsal edge become strongly swollen. The spiral commencement of the test is partially hidden by the overlapping of the last three chambers. There is a distinct umbilical excavation above the axis of the spiral. The dorsal edge of the last four chambers has a sinuous outline, and is deeply grooved. The aperture is terminal and the border marked with radiating lines. The front peripheral edge of the spiral portion of the test is rather sharply keeled. Length  $1/45$  in.; greatest breadth  $1/80$  in.

At first sight the ornamentation of *C. Bradyana* reminds one of *C. gemmata* Brady.\* The sutural ridges, however, in the former species are not broken up in such a manner as to give the distinctly beaded ornamentation seen in the latter form; and, further, the peripheral aspect of *C. Bradyana* shows a keeled edge in the earlier part of the test, whereas in *C. gemmata* the peripheral edge is quite square. Although the two forms *C. Bradyana* and *C. complanata* are fairly distinct, yet they have some characters in common, and it is instructive to note that *C. complanata* is confined to the uppermost beds of the Gault, whilst *C. Bradyana* ranges through the middle and part of the upper portions.

*C. Bradyana* was found in zone x., very common; zone xi., 50 ft. from the top, rare; 45 ft., rare; 40 ft., very rare; 35 ft., frequent; 25 ft., very rare.

*Cristellaria planiuscula* Reuss, plate X. fig. 14 *a, b*.

*C. planiuscula* Reuss, 1862, Sitzungsber. d. k. Ak. Wiss. Wien, vol. xlv. p. 71, plate vii. fig. 5 1 *a, b*. *C. planiuscula* Berthelin, 1880, Mém. Soc. géol. France, sér. 3, vol. i. No. 5, p. 53, plate iii. fig. 25 *a, b*.

This species was found by Reuss in the Neocomian beds of North Germany, and Berthelin describes it from the Gault of France.

It was found at Folkestone in zone ii., specimen *a*, very rare; zone ii., specimen *b*, very rare; zone iii., rare; zone iv., very rare; zone v., very rare; zone xi., 55 ft. from the top, very rare; 25 ft., very rare; 20 ft., very rare; 6 ft., very rare.

\* Chall. Rep., ix. p. 554, pl. lxxi. figs. 6, 7.



X.—*On a Simple Method of Measuring the Refractive Indices of Mounting and Immersion Media.*

By EDWARD M. NELSON, F.R.M.S.

(Read 21st November, 1894.)

SINCE my last communication \* on this subject I have made some improvements in the plan, without unduly increasing the complexity of the apparatus. Before explaining them let me say how obvious is the necessity for some simple and inexpensive apparatus by which the refractive index of any medium may be readily determined.

All those who take sufficient interest in the Microscope to master the optical principles upon which it is based know what an important part is assigned to the refractive indices of mounting and immersion media. Unfortunately all apparatus for the measurement of the refractive index is expensive, and quite beyond the reach of the ordinary Microscopist.

An attempt to simplify the method was made by Dr. Pigott.† He measured the refractive index by ascertaining by means of a Microscope ‡ the difference between the actual and the observed depth of the medium. Now if  $\mu$  is the refractive index of the medium, the observed depth will be  $\frac{1}{\mu}$  of the true depth, therefore  $\mu$  may be determined by dividing the actual depth by the observed depth. In making these measurements it is necessary that the observed rays be nearly normal to the surface, therefore Microscope objectives which possess considerable aperture are not suitable for this purpose. If the objectives be stopped down to prevent obliquity in the observed rays, then there will be a corresponding want of definiteness with regard to the focal point. Dr. Pigott does not seem to have considered that it is necessary that the observed ray should be nearly normal to the surface, for he says, "The well-known delicacy of evanishment of a point under a good Microscope seemed to afford an exquisite test of distance." This "well-known delicacy of evanishment" is dependent on a large aperture, which implies obliquity in the observing ray, which means aberration in the medium, which causes an error in the measurement of the observed depth, which of course impairs the accuracy of the final result.

\* This Journal, 1892, p. 875.

† M. M. J., xvi. (1876) p. 294. (It is not an original idea.)

‡ The instrument shown in the cut in Dr. Pigott's paper could not be used for any ordinary microscopical work, and would probably cost more than an ordinary refractometer.

The second method was an ingenious one devised by Prof. H. L. Smith.\* He filled a hollow slide with the medium to be measured, and covering it with a slip he placed it in an adapter above the object-glass of his Microscope. It is obvious that if the refractive index of the medium were the same as that of the enclosing glass no more alteration would be caused in the focus of the entire Microscope than would be caused by the insertion of a piece of plane glass of similar refractive index and of similar thickness. If, however, the refractive index of the medium differs from that of the enclosing glass, the appliance will act as a lens with either a positive or negative focus according to the direction in which the refractive index of the medium differs from that of the enclosing glass. Fiducial points were then marked on the limb of the instrument, which indicated the focal positions of the body when a certain eye-piece and a certain objective were employed, and when the hollow of the slide was filled with oil of cinnamon (1.6), oil of cedar (1.52), glycerin (1.41), and water (1.33).† By interpolation the refractive indices of other substances are estimated. This is an excellent method, for while it is inexpensive and free from all complications it will nevertheless meet the wants of the ordinary Microscopist. For indices lying between 1.6 and 1.33 the readings will be sufficiently accurate for all practical purposes, but with higher indices the ground is not so sure.

With my former appliance I found that there was not, except between certain limits, an increase in focus commensurate with the alteration in the refractive index. The plan now brought forward ensures an alteration of 2 in. in the focus for every change of .25 in refractive indices from 1.0 to 3.0.

The apparatus consists of a piece of plane glass  $3 \times 1$ , and the following lenses: a plano-convex, a plano-concave, an equi-concave, and two equi-convex. The radius of all these curves is an inch, the concaves being hollowed out of  $3 \times 1$  slips; the diameter of the convex lenses is  $\frac{3}{4}$  in. and of the concaves  $\frac{1}{2}$  in. There is also provided a wooden  $3 \times 1$  slip with a  $\frac{3}{8}$  hole in the centre; this hole is bevelled or countersunk on one side, so that when one of the equi-convex lenses is placed in it the upper surface of the convex lens may be just flush with the top of the slip; in other words, when the glass slip is placed on the top of the wooden slip the underneath part of the glass slip is just to touch the upper surface of the equi-convex lens as in G.

On reference to the table it will be seen that these lenses are arranged in eight different groups to suit the different refractive indices of media to be measured. In the first and third the medium is placed between the lens and the slip, in the fifth it is placed between the lenses, and in the seventh between one of the lenses and the slip.

\* This Journal, 1885, p. 1066, and Amer. Mon. Micr. Journ., vi. (1885) p. 183.

† These are the refractive indices as given in his paper.

In the second the plano-concave is filled up with the medium, which is then covered by the plano-convex lens, but in the fourth and sixth it is covered by the slip, and in the eighth by the plano-convex lens. It is obvious that in the even numbers (B, D, F, H), the medium acts as a convex, and in the odd (A, C, E, G) as a concave lens. The method of measuring the focus is very simple: the medium having been put in position, the slide is first placed on the wooden slip and then on the top of the substage of the Microscope, which is used vertically. (The object of the wooden slip is threefold; first to prevent the slide when heated touching the brass-work, secondly to act as a diaphragm, and thirdly to hold the lenses in cases E and G.) A slip with a mark on its lower surface, such as an ordinary stage micrometer, cover downwards, is placed on the stage, an inch or  $\frac{2}{3}$  objective is screwed on the nose-piece, and the mark is brought into focus.

The substage is now moved until the image of a distant tree or chimney-pot is focused by the lenses containing the medium on the same mark. The plane mirror is of course used, and further it is as well to test the plane mirror by the sun's rays, because so-called plane mirrors are often concaves of long foci, in which case they would be unsuitable for this purpose.

The focus, F, is the distance measured between the medium and the mark on the lower side of the slip on the stage.

With regard to the construction of the lenses, care should be exercised to make them not only true to the radius of 1 in., but also of glass having precisely the same refractive index, which should be as close to 1.5 as possible. In the formulæ  $\mu$  is the refractive index of the medium to be measured, and  $\mu'$  that of the glass of which the lenses are composed, F being the focus of the entire combination with the medium in position.







Example:—In C let  $\mu' = \frac{3}{2}$ , and F = 2.

Then 
$$\mu = 3 - 1 - \frac{1}{2} = \frac{3}{2}.$$

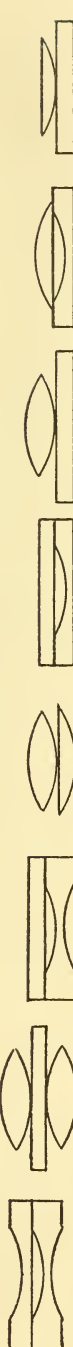
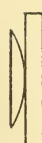
In D let F = 2.

Then 
$$\mu = \frac{3}{2} + \frac{1}{2} = 2.$$

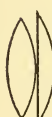
My subject is now finished, but before closing it may interest those who study optics to know that these eight groups of lenses are not a haphazard arrangement. A little consideration will show that a single plano-convex lens of 1 in. radius arranged as in A will yield a focus of 2 to 4 in., with a variation in  $\mu$  of 1 to 1.25, and it is equally easy to see that a focus of 4 to 2 in. will be obtained with a variation in  $\mu$  of 1.25 to 1.5 by a plano-convex lens of the same radius composed of the medium itself. But as the medium must be

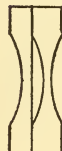
Fig.	Formula. Ref. index of medium = $\mu$ , Ref. index of lens = $\mu'$ , Radius = 1.	Variation of $\mu$ when $\mu' = \frac{3}{2}$ .	Variation of Focus in Inches.	
A	$\mu = \mu' - \frac{1}{F}$	1 - 1.25	2 - 4	
B	$\mu = 1 + \frac{1}{F}$	1.25 - 1.5	4 - 2	
C	$\mu = 2\mu' - 1 - \frac{1}{F}$	1.5 - 1.75	2 - 4	
D	$\mu = \mu' + \frac{1}{F}$	1.75 - 2	4 - 2	
E	$\mu = 3\mu' - 2 - \frac{1}{F}$	2 - 2.25	2 - 4	
F	$\mu = 2\mu' - 1 + \frac{1}{F}$	2.25 - 2.5	4 - 2	
G	$\mu = 4\mu' - 3 - \frac{1}{F}$	2.5 - 2.75	2 - 4	
H	$\mu = 3\mu' - 2 + \frac{1}{F}$	2.75 - 3	4 - 2	



held in a concave lens, it is necessary to neutralize this concave lens by a plano-convex of similar glass and radius, as in B.

It is not so easy, however, to discover a law for the arrangement of the next six. The method is explained thus:—

When  $\mu = \frac{3}{2}$  an increase of 0.5 is an increase of  $\frac{\mu}{3}$ . The difference in the focus F caused by this increase may be determined thus:—

$$\frac{1}{F} = \frac{\frac{4\mu}{3} - 1}{r} - \frac{\mu - 1}{r} = \frac{\mu}{3r}.$$

So when  $\mu = \frac{3}{2}$ ,  $F = 2r$ , or the focus of a plano-convex lens. Therefore to maintain the same focus, a plano-convex lens must be added to A to obtain C, and another to get E, and so on with the odd numbers. With the even numbers we have to add a plano-concave; thus D is obtained from B, because taking away the plano-convex lens is tantamount to adding a plano-concave, and by adding another concave to D we obtain F, and so on.

---

SUMMARY OF CURRENT RESEARCHES  
RELATING TO  
ZOOLOGY AND BOTANY  
(PRINCIPALLY INVERTEBRATA AND CRYPTOGAMIA),  
MICROSCOPY, ETC.

*Including Original Communications from Fellows and Others.\**

ZOOLOGY.

A. VERTEBRATA:—Embryology, Histology, and General.

a. Embryology.†

**Experimental Embryology.**—Prof. O. Hertwig ‡ has made fresh experiments on the influence of external conditions on the development of the ova of the frog (*Rana fusca*). The maximum temperature at which the ova will develop normally (though more rapidly than usual) is 25° C. Higher temperatures affect the ova injuriously, particularly the vegetative part, and partial forms occurred like those which Roux produced by his puncturing method. The animal half is the hardier, for it has relatively more protoplasm, and that is more thoroughly under nuclear influence. Lowering the temperature inhibits development, just as an increase accelerates it.

Prof. Hertwig has also experimented on the influence of salt-solutions, as Morgan and Umé Tsuda have done. With solutions of 3 : 500 the formation of the blastopore and the development of the brain were especially affected. The invagination forming the archenteron was restricted to a small portion at the margin of the yolk-area, very much as in meroblastic discoidal segmentation. As regards the brain, the abnormality induced was comparable to hemicephalous and anencephalous conditions in human teratology, a resemblance on which the author comments.

\* The Society are not intended to be denoted by the editorial "we," and they do not hold themselves responsible for the views of the authors of the papers noted, nor for any claim to novelty or otherwise made by them. The object of this part of the Journal is to present a summary of the papers *as actually published*, and to describe and illustrate Instruments, Apparatus, &c., which are either new or have not been previously described in this country.

† This section includes not only papers relating to Embryology properly so called, but also those dealing with Evolution, Development and Reproduction, and allied subjects.

‡ SB. K. Preuss. Akad., 1894, pp. 311-7.

Dr. Ch. Féré\* has experimented on the influence of the temperature on the incubation of hens' eggs.

(1)	At 38°, 20 were normal out of 24 = 83·33 per cent.
	" 41°, 3                   "           " 21 = 12·5       "
(2)	" 38°, 12               "           " 18 = 66·66     "
	" 40°, 2                   "           " 18 = 11·11     "
(3)	" 38°, 30               "           " 42 = 71·08     "
	" 39°, 16               "           " 42 = 38·09     "

And so on with other experiments. Below 37° the number of developments diminished, 59·45 per cent. at 36°, 56·52 at 35°, 41·66 at 34°. The influence of alcoholic vapour increased in effect on each side of 38°. The general conclusion is that 38° is the optimum temperature during the early days of incubation, and it is also most favourable for the resistance of injurious influences which may have operated before incubation. This has its bearings on "the prophylactic hygiene of degeneration."

Dr. F. Braem† has some interesting suggestions in regard to the influence of pressure on cleavage. The results reached by Pfüger, Roux, and Driesch show that the segmentation-spindles always lie at right angles to the direction of greatest pressure, the long axis of the spindle seeking the direction of least pressure. In fact, the disposition of the spindles conforms to the conditions of least resistance; the cells are so disposed that they secure the greatest freedom for expansion. This is complicated, however, by the fact that mere contact, as well as pressure, appears to have its effect. What Braem does is to apply the results of experiment to the elucidation of normal cleavage, showing how the succession of events in the development of *Synapta* is influenced by the pressure of the egg-membrane on the blastomeres and by their pressure on one another. He tries to explain, for instance, how a blastosphere stage is reached.

**An Abnormal Human Embryo.**‡—Sig. C. Giacomini adds a thirteenth case to his important series of abnormalities. He describes a defect in the development of the amnion, in the head-fold, and a correlated atrophied condition in the embryo.

**Origin of the Scleroblasts.**§—Dr. H. Klaatsch makes an important contribution to our knowledge of osteogenesis. From a study of the development of the placoid scales in *Mustelus* and other Selachii, he comes to the conclusion that the scleroblasts arise from the ectoderm. They are derived from the same material as that which forms the enamel. Gradually the originally homogeneous rudiment is separated into a part previously called mesodermic and a part which remains continuous with the ectoderm. The separation begins from the centre, and for a long time there remains a peripheral portion at the outer margin of the fold which serves as a germinal layer for scleroblasts and continues to furnish new material. Klaatsch extends this result to the development of teeth in *Mustelus*, and to the horny rays in the fins of Selachians. In

\* Journ. de l'Anat. et de Physiol., xxx. (1894) pp. 352-65.

† Biol. Centralbl., xiv. (1894) pp. 340-53 (5 figs).

‡ Atti R. Accad. Torino, xxix. (1893-4) pp. 638-53 (1 pl.).

§ Morph. Jahrb., xxi. (1894) pp. 153-240 (5 pls.).

the last case, a mesodermic proliferation at the free margin of the fin appears to be originated from the ectoderm, the scleroblasts of the rays are ectodermic to begin with, and a germinal zone at the margin continues to furnish fresh material as growth goes on. He finds further corroboration in a study of Teleosteans, and extends his conclusions tentatively to higher Vertebrates. At the end of his paper there is an interesting speculative suggestion as to the possible connection between skeleton-making and epidermic excretion, but these and other speculations are perhaps of less importance than his definite facts, showing in certain cases the ectodermic origin of scleroblasts for which the mesoderm previously got credit. Here we have another corroboration of Kleinenberg's words, "There is no mesoderm."

**Phylogeny of the Tongue.\***—Prof. C. Gegenbaur begins an interesting essay on the tongue with a brief sketch of the numerous modifications which this organ exhibits in the Vertebrate series. In Fishes it is a fold of mucous membrane covering part of the hyoid, with no mobility except what it owes to the hyoid, and with considerable monotony of structure. It includes mucous membrane (it may be with hard teeth), a skeletal support, fat and connective tissue. It is with Amphibians that the mobile muscular tongue begins, which has proved itself so useful an organ. But how came it to be muscular? "Das Erreichte kann nicht als Ursache gelten."

The author describes what he has observed as to the development of the tongue in newt and salamander, how a small protrusion of mucous membrane occurs in front of the hyoid, how this exhibits connective-tissue proliferation, how it becomes in part a sensory but yet more a glandular organ, and how finally, during metamorphosis, muscular strands from the sterno-hyoid and genio-hyoid enter into its composition.

The tongue is first then a glandular organ, a function fully justified in the Amphibian's later life, and the original import of the musculature was probably in connection with the glands. Thus the missing link in the evolution of the tongue is plain, the musculature was from the first of use to *compress the glands*. The dwindling of the glandular function, the increase of musculature, the taking on of new functions, the modifications of detail, present no special difficulty. It is thus that ontogeny helps out phylogeny.

**Development of Venous System of Mammals.†**—Prof. F. Hochstetter has followed up his previous researches by a study of the venous system in embryos of rabbit, cat, man, &c. He first discusses the venous system of the liver and then the modifications of the posterior cardinals and the development of the postcaval. After a comparative survey of mammals, he notes a series of important variations which occur. His paper is necessarily very complex, and we must restrict ourselves to one section of it.

Of the right posterior cardinal the proximal portion remains, from its opening into the ductus Cuvieri (later V. cava superior sinistra) to the eighth thoracic segment, as the main stem of the V. azygos. From

\* Morphol. Jahrb., xxi. (1894) pp. 1-18 (5 figs.).

† Op. cit., xx. (1893) pp. 543-648 (3 pls., 16 figs.).



the eighth thoracic segment caudalwards the *V. azygos* is a secondary formation. The caudal portion of the right cardinal, after it has altered its relation to the uroter, remains as the cardinal portion of the postcaval from the entrance of the renal veins caudalwards. The proximal portion of the postcaval is formed from two distinct parts, a proximal part arising from the union of the *V. omphalo-mesenterica* and the *V. umbilicalis dextra* and a caudal part which represents an anastomosis between the cardinal veins and the proximal part of the postcaval. Of the left posterior cardinal there is usually no trace left in the thoracic region; in the abdominal region it persists either between the *V. lumbalis transversa posterior* and the *V. renalis sinistra*, or as a continuation of the left spermatic. The pelvic portion of the cardinals is modified by fusion in the common internal iliac. The caudal portion persists on one side or on both sides as the caudal vein (*sacralis media*).

**Sero-Amniotic Connection and Fœtal Membranes of Chick.\***—Mr. S. Hirota describes these structures in the Chick, and compares them with the same parts in the Chelonia. The essential points in which they agree may be summarized thus:—

(1) The chick has, at the posterior edge of the amniotic fold, a constant deltoid area free from the mesoblast; this is observed in comparatively later stages in Chelonia.

(2) As long as the amniotic fold grows posteriorly, the sero-amniotic connection and the remnant of the epiblastic deltoid area is equally prolonged posteriorly until it becomes a long string.

(3) This connection is more or less widened on both sides of the epiblastic bridge by the entrance of the mesoblastic tissue.

(4) The epiblastic layers of the extra-embryonic parts are stratified, at least near the connection.

(5) The connection between the serous envelope and the amnion persists during egg-life, and there is no direct continuity between the extra-embryonic coelomic cavities of the two sides along the length of the connection.

(6) The growth of the allantois is greatly influenced in later stages by the sero-amniotic connection.

The essential points of difference are—

(1) In the Chick the amniotic fold arises at a comparatively later stage than in the Chelonia, and has no conspicuous area free from mesoblast.

(2) In Chelonia the epiblastic delta of the amniotic fold is always larger than that of the Chick, but in the latter it is enormously thickened dorso-ventrally.

(3) In Chelonia there is no proper tail-fold, while the Chick has no trace of the posterior tube which forms so conspicuous a feature of the Chelonian amnion.

(4) The epiblast bridge of the connection seems to be persistent in Chelonia, while in the Chick it is replaced by mesoblast.

(5) The sero-amniotic connection is not perforated in Chelonia, and it is not enclosed within the foetal membranes, as these Reptiles have no albumen-sac.

\* Journ. Coll. Sci. Imp. Univ. Japan, vi. (1894) pp. 337-70 (3 pls., 16 figs.).

**Gastrulation in Chelonia.\***—Prof. K. Mitsukuri finds from a study of embryos of *Chelonia caouana*, *Trionyx japonicus* and *Clemmys japonica*, that when segmentation has gone on for some time two layers are established in the blastoderm, the epiblast is composed of columnar cells, and the lower layer of irregular stellate cells, which probably do not form a complete sheet. This separation into two layers takes place in all parts of the blastoderm, except a small area at the posterior end of the future embryo, where there is a thick knob formed of a network of cells; this is the primitive plate or knob.

In the middle of this knob an invagination cavity at first goes straight downwards, but soon takes a forward horizontal course. This is the archenteron, with the blastopore; the roof of the cavity becomes continuous with the epiblast of the embryonic shield and becomes columnar; out of the median part is formed the notochord, and from columnar epithelium on each side there is developed the gastral mesoblast. The floor of the cavity gives rise, posteriorly, to the peristomial mesoblast, while the anterior part is absorbed, and the invagination cavity is thus put into communication with the large subgerminal cavity in the yolk. The primitive knob grows forwards, and its advance in later stages is marked by a zone of cell-network with a compact central area. When the whole of the ventral surface of the embryonic shield has been covered the process stops, and the cell-network is changed into compact cellular sheets. The future embryo, and consequently the definite alimentary canal, is formed entirely within the area which is covered ventrally by the part derived from the primitive knob.

Or the results may be put thus. From the epiblast of the embryonic shield the epiblast and its derivatives are derived. In the region of the primitive plate and its anterior enlargement are produced the invagination cavity (archenteron), the yolk-plug, the notochord, the mesoblast, and the definite hypoblast with its derivatives. The primitive lower layer contributes to the future animal only in so far as some of its cells are unrecognizably incorporated with the cells of the primitive knob, when the latter spreads itself over the ventral surface of the embryonic shield.

Of points which the author desires specially to emphasize we may note—

(1) The primitive plate or knob is raw material left at the centre of the blastoderm, by means of which certain palingenetic processes are gone through.

(2) The yolk-sac must be regarded as a ventral appendage of the archenteron in which nutrient matter is stored, but

(3) Owing to the enormous size of this sac it and the archenteron are formed separately from one another, and come only secondarily into contact. ☐

**Development of Bulbus Cordis in Amphibians and Reptiles.†**—Dr. A. Langer has studied this in frog, salamander, and lizard, in order to discover what relation there is between the conus of Amphibians and the bulbus of Birds and Reptiles. The arterial valves of the lizard

\* Journ. Coll. Sci. Imp. Univ. Japan, vi. (1894) pp. 227-77 (3 pls. and 8 figs.). See this Journal, 1893, p. 607.

† Morphol. Jahrb., xxi. (1894) pp. 40-67 (22 figs.).

develop somewhat late, distally to the ostium, but at a considerable distance proximally from the end of the bulbus; the proximal end of the bulbus is involved in the formation of the ventricle; the distal end divides into the three arterial stems; the pads (*Wülste*) of the bulbus are histological marks of its cardiac nature, and these are lost as such in the distal portion, while their modification is expressed histologically in the peripheral vessels; the arterial valves of Amniota do not arise at the ostium bulbi, but correspond to the distal valves of Amphibians.

**Development of Abdominal Vein in Amphibia.\***—Prof. F. Hochstetter has studied this in *Salamandra maculata*, and comes to the probable conclusion that the rudiment of the abdominal vein in Amphibia is the foundation for the development of the umbilical veins of Amniota. Its cranial portion, which has only a transitory rôle in Amphibia, is directly modified into the corresponding portion of the umbilical vein, while its caudal portion exhibits in many Reptiles the same relations as in Amphibia, but is undeveloped in Birds and Mammals.

**Development of Hypophysis and Saccus vasculosus in Teleostei and Amphibia.†**—Herr H. Lundborg has had for investigation embryos of *Salmo salar*, *S. alpinus*, the Axolotl, and the Triton. He finds that, in the Salmonidæ, the hypophysis is an ectodermal structure; though the ectoderm in its neighbourhood consists of two layers of cells, it is the deeper one that takes part in forming the hypophysis. From the first the hypophysis is double, though the two ectodermal invaginations lie close to one another; the partition between them thins after some time, and then breaks first in the middle, and afterwards before and behind. A hypophysial duct (or, more correctly, stalk) appears, but it is very short, solid, and vertical in direction. As soon as the embryos are set free the duct disappears.

At the stage when the *Salmo* is about to escape there is developed on both the upper and the lower jaw a dermal fold, which bounds the mouth-opening. These folds are secondary structures, and as the teeth are developed on them they are not, as Dohrn supposed, endodermal, but ectodermal structures.

The glandula infundibuli does not begin to be separated off from the infundibulum till a comparatively late period (in *S. salar* the 65th day); in the Axolotl it appears still later; there is always a vertical orifice of communication between the infundibulum and the rudiment of the organ.

**Development of Olfactory Organ in Teleostei.‡**—Herr J. F. Holm gives a brief account of the development of this organ in *Salmo salar*, from which it appears that the process more closely resembles that of Elasmobranch Fishes than of *Lepidosteus*, as described by the late F. M. Balfour, who with C. K. Hoffmann seems alone to have studied the history of this organ in Fish.

**Ova and Larvæ of British Fishes.§**—Prof. W. C. McIntosh communicates the results of his studies at St. Andrews on *Hippoglossus*

\* Morphol. Jahrb., xxi. (1894) pp. 19–27 (1 pl.).

† Zool. Jahrb. (Abth. f. Anat.), vii. (1894) pp. 667–87 (2 pls., 4 figs.).

‡ Morph. Jahrb., xxi. (1894) pp. 620–4 (1 pl., 1 fig.).

§ Ann. and Mag. Nat. Hist., xiv. (1894) pp. 189–95.

*vulgaris*, *Gadus minutus*, *Brosmius brosme*, and *Arnoglossus megastoma*. Details only are given, and there are no general results apparent.

### B. Histology.

**Archoplasm and Attraction Sphere.\***—Mr. J. E. S. Moore is of opinion that we cannot regard the archoplasmic portion of the attraction-sphere as a permanent organ of the cell, any more than ripples are the permanent features of the surface of a pond. On the other hand, all the normal recent investigations on the karyokinetic propagation of cells show that the centrosomes retain their individuality through every change. The discoveries of Field with regard to the spermatozoa of Echinoderms, and of the author on Mammalian spermatozoa seem to show that the centrosomes, unlike the other constituents of the sphere, retain their individuality during successive mitoses, and are incorporated as an essential constituent of the spermatozoa.

The observations of Fol, and the more recent studies of Fick, show clearly that these bodies assume their old functions as dominants of the attractive process in the initial stages of fertilization. We must, with Van Beneden, regard them as organs of the cell.

**Chemical Physiology of the Cell.†**—Mr. R. H. Chittenden concludes his valuable critical review of recent investigations on the physiological chemistry of the cell. He discusses especially the nuclein substances. Nuclear contents consist of a globulin-like body (as in cytoplasm) which may be digested into proteoses and peptones, and of an indigestible residue of nuclein substances, various combinations of protein and nuclein acid, the latter rich in phosphorus. Perhaps these are fragments of a still more complex molecule. After discussing the xanthin bases, adenin, guanin, xanthin, and hypoxanthin, derived from nuclein by treatment with dilute mineral acids, the author says, "From our review we may conclude that the nucleus is in some way intimately connected with the processes which lead to the formation of organic materials. Whatever other functions it may possess, the nucleus is certainly able, in virtue of the properties of its component substances, to superintend the metabolic processes which take place in the cell, to modify and regulate the metabolism."

### γ. General.

**Function of Equilibration.‡**—Herr A. Bethe discusses the various ways in which equilibration is secured. Touch or a sense of pressure is only of importance when the animal moves in air or water and is at the same time in contact with some solid body; in free-swimming or flying animals the pressure on all sides is approximately the same. There is much evidence in favour of connecting the semicircular canals and the otolithic apparatus with this function of equilibration, but what of those animals in which these are quite absent? Delage has suggested that in insects, for instance, sight is important in this connection. But blinded bats fly as securely as before, blind cave-animals and

\* Nature, l. (1894) pp. 478 and 9 (4 figs.).

† Biol. Centralbl., xiv. (1894) pp. 375-84.

‡ Tom. cit., pp. 95-114 (3 figs.).



deep-sea animals keep their balance, and the author finds that equilibration is not interfered with when he covers the eyes of crayfish, *Narcoris cymicoides*, *Corixa carinata*, *Acilius sulcatus*, *Ilybius uliginosus*, *Æschna juncea*, *Agrion elegans*, *Pieris brassicæ*, and a Phryganid. The crayfish moves as usual, but knocks his head against the side of the aquarium; the insects flew well, but went high up in the air.

The simplest means of orientation is that afforded by a difference between the specific gravity of the organism and that of the medium, for thus the animal is made aware of up and down directions. This can be shown by the behaviour of aquatic animals when placed in a medium specifically heavier than they are if they are specifically heavier than the water, or specifically lighter in the reverse case. In such conditions those which normally breathe in water swim upside down; those which breathe air keep their normal position and come to the surface. The author discusses the mechanical conditions which explain these facts.

**Correlations of the Volumes and Surfaces of Organisms.\***—Dr. J. A. Ryder finds that there are only three ways in which living Nature has found it possible to escape the conditions imposed by the simple aggregating impulses of the forces of gravitation and surface tension. All three have been resorted to, with all their multiform consequences, by the Protozoa and Protophyta, so that it is now difficult to decide which of the three was the most primitive form—the segmenting spherical, the alternate cylindrical, or the flattened discoidal.

The vacuolation and gradual dilatation of the simple spherical form into a vesicle or segmented blastula probably led to the evolution of the Metazoa, while indefinite lengthening and branching of cell-aggregates seems to have been the line along which plant-cells became coherent, and gave rise to the Metaphyta.

The changes of shape suffered by all organisms may be reduced to two categories:—

I. Indefinite stretching in linear directions, of which dichotomy is only a special form.

II. Indefinite flattening, compression, or attenuation of some or all of their substance into a flat plate or into laminae.

## B. INVERTEBRATA.

**Catalogue of Parasites.†**—Messrs. C. W. Stiles and A. Hassall have prepared a preliminary catalogue of the parasites contained in the collections of the U.S. Bureau of Animal Industry, U.S. Army Medical Museum, the Leidy collection, and in the collections made by the authors themselves. The host, the locality, the collector and collection are stated in a regular manner.

**Food of two Commensals.‡**—M. H. Coupin has studied the habits of *Nereilepas fucata*, the worm which is very commonly found living with Pagurids in the shells of *Buccinum*; it is generally supposed that the annelid lives on the dejecta of the crustacean; but the author's

\* Contrib. Zool. Lab. Univ. Pennsylvania, i. (1893) pp. 3-36 (1 pl.).

† Veterinary Mag., 1894, pp. 245-53, 331-54.

‡ Comptes Rendus, cxix. (1894) pp. 540-3.

observations show that the worm really steals the hermit-crab's food, and that it does not feed on fæces of its host. *Nereilepas* then is a true parasite and not a commensal. *Pinnotheres*, which has been thought to be a commensal of Lamellibranchs, is also shown to rob its host of its food.

#### Mollusca.

Indian Deep-Sea Mollusca.\*—Mr. E. A. Smith has a report on the first set of Mollusca dredged from deep water in the Bay of Bengal. There are no new genera, and some of the species have a close resemblance to others which occur in remote parts of the world; two Pleurotomids have quite the appearance of northern forms or inhabitants of cold regions.

#### γ. Gastropoda.

Cleavage and Germ-Layer-Formation in *Stylommatophora*.†—Dr. F. Schmidt's embryological investigations have chiefly been made on *Succinea putris*, *Limax agrestis*, and species of *Clausilia*. With regard to the cleavage-process, the following are his more important conclusions. The directive corpuscle, soon after its extrusion, divides into two equal cells; it remains connected by a cord of albumen with the egg until the latest stages of cleavage.

The second plane of cleavage, which like the first is vertical, is at right angles to the first, and lies in such a way that the four spherical cells, which are exactly like one another, lie in the same plane. The next plane of cleavage is horizontal, and therefore perpendicular to the two first, divides each of the four cells into a larger part, and one much smaller, which is turned towards the animal pole. The next plane is likewise horizontal, and divides the four large cells at the vegetative pole into two unequal elements. The smaller cells at the animal pole are next divided into two by a vertical groove; the next again divides the vegetative cells, and the whole mass now consists of twenty cells. The difference in size between the cells at the animal and the vegetative poles remains during the whole course of segmentation. On the whole, then, the author gives a similar history of cleavage to that detailed by other observers of the development of the Pulmonate Gastropods.

With respect to the origin of the mesoderm, the following conclusion may be formulated; there is so far an agreement in the formation of the mesoderm of Gastropods that it takes its origin from the primary endoderm, either early in the form of primitive mesoderm cells, or, later, in the form of an outgrowth from the archenteron.

Gonads of *Ancylus*.‡—Prof. Lacaze-Duthiers describes the reproductive organs of *Ancylus fluviatilis*. The hermaphrodite organ is small, its elongated conical acini converge to the "androgynous canal." Leaving the essential organ, this duct becomes associated with the albumen gland, though the author objects to this term. The sperm-duct and oviduct follow, and the different routes of spermatozoa and ova are compared to the passage of the food through the ruminant alimentary canal. A second annexed gland is the shell-gland. The copulatory

\* Ann. and Mag. Nat. Hist., xiv. (1894) pp. 157-74 (3 pls.).

† Zool. Jahrb. (Abth. f. Anat.), vii. (1894) pp. 638-717 (1 pl., 1 fig.).

‡ Comptes Rendus, cxviii. (1894) pp. 560-6.

region, the flagellum, and other parts are described briefly, but a full account is promised. In the so-called receptaculum seminis or copulatory vesicle, no active spermatozoa were found.

**Arrangement, Correlation, and Function of Pallial Organs of Tectibranchiata.\***—The general results of Mr. J. D. F. Gilchrist may be thus summed up; while the presence of a shell is characteristic of one large division of the Mollusca, its absence is just as characteristic for another. The result of the calcareous covering is special adaptation for respiration, in the form of a ciliated gill in the mantle-chamber, which must, for respiratory purposes, produce a sufficiently strong stream of water. This stream leads to the development of a special sensory organ (osphradium) at a point where there is a suitable nerve-supply. In connection with this there may appear an external organ, the siphon, which is well developed in many Prosobranchiata; in general it has a tendency to approximate to the cephalic or sensory region. In the Tectibranchiata it is wanting, and its absence may be explained by the distance the mantle-cavity is from the cephalic region.

When the animal becomes inedible there is a new turn; it can come out from its shell; large parapodia, too large to be withdrawn into the shell, are developed, and serve for swimming or crawling; these parapodia may become powerful respiratory organs; the gills and the water-stream become less necessary, and may disappear; the head-region is the most suitable place for sensory stimuli from the surrounding medium, and this may lead to the development of rhinophors, and the gradual disappearance of the old osphradium. And with this there may be the loss of the incurrent siphon and the backward movement of the pallial cavity. The filling up of this last and the disappearance of the shell are correlative changes. All these changes may be very well seen in existing Tectibranchiata.

But the study of the "pallial complex" shows not only the further development of the Prosobranchiata, but also an approximation to the Nudibranchiata. The respiratory processes are shown by *Pleurobranchæa* and *Umbrella* to be either parapodial, or processes of the mantle or of the general body-wall.

That the osphradium is developed in direct relation to the water-stream, and in indirect relation to the rhinophors, is made still clearer if we compare it with similar phenomena in air-breathing animals. The Prosobranchiata have a specialized external organ in the stream; the Opisthobranchiata, like Insects, in which there is no special localized stream, have an olfactory organ in the cephalic region.

With regard to differences in the structure of the gills, it is pointed out that the gill of the *Aplysia*-type, which is characteristic of the Cephalaspideæ and Anaspideæ, stands out from the body, and forms almost a right angle with its long axis; those of the Notaspideæ, in which the gills are only incompletely protected by the mantle, lie close to the body, and have their axis almost parallel to it.

**Reversal of Cleavage in a Sinistral Gastropod.†**—Mr. H. E. Crampton has a brief account of some observations on the early stages

\* Jenaische Zeitschr., xxviii. (1894) pp. 408-59 (21 figs.).

† Ann. New York Acad. Sci., viii. (1894) pp. 167-70 (1 pl.).

in the development of *Physa heterostropha*, the adult of which has a sinistral shell, and of *Limnæa columella*, whose shell is dextral. The type of cleavage in these eggs is spiral, but that of *Physa* is totally reversed. The first evidence of variation appears at a late 2-cell stage. Here the spindles for the next cleavage, instead of being inclined from left below to right above, as they are in *Limnæa*, are inclined from right below to left above. This total reversion brings about in the 4-cell stage the reversion of the cross-furrows.

The author does not seem to think that an immediate answer can be given to the question whether there is any correlation between the sinistral shell of the adult *Physa* and the unique method of cleavage.

**Experimental Nanism.\***—M. H. de Varigny has repeated and extended the late Prof. Semper's observations on reduction of size in *Limnæas auricularis* and *L. stagnalis*. He comes to the conclusion that the favourable influence of large volume is not due, as Semper supposed, to the presence in the water of a chemical constituent which favours growth, but that "nanism" is due to want of activity and movement.

**Function of Kidney of Helix.†**—M. L. Cuénot finds that if Snails or Slugs are kept in captivity they get rid of masses formed entirely of uric concretions, and exactly similar to those contained in the renal cells. In other words, the renal concretions of these animals are eliminated as such and not altered on their way out. A fortnight may elapse between two successive evacuations of these deposits.

**Branchiate Pulmonates.‡**—Dr. P. Pelsencer has discovered among the aquatic Pulmonates of Madagascar a sinistral form which is normally possessed of a well-formed gill; this gill is folded and not pectinate, and is fixed by its base only; it is not the homologue of the ctenidium of other Gastropods, for it is placed quite outside the pallial cavity; it is, in fact, a new structure.

A study of Belgian forms shows that there are signs of a like organ in *Planorbis* and *Ancylus*; *P. corneus* has, outside the lung cavity, a flattened tegumentary lobe, the structure of which shows its respiratory function; a similar, but smaller, lobe is present in *P. marginatus*. *Ancylus*, which has no lung at all, has the same lobe. The facts that the structure is a neomorph, and that the Pulmonata generally have lost their original ctenidium, afford an interesting example of the impossibility of a lost organ reappearing.

The Madagascar form which has been called *Physa lamellata* is the type of a new genus which the author proposes to call *Pulmobranchia*.

**Notes on Polyplacophora.§**—Herr B. Haller describes some points of interest in the large *Chiton magnificus* which he regards as a primitive species. The most interesting fact is that this species has four pairs of auricular openings into the ventricle, while other (younger) forms have two pairs, and some only one pair. This is a further argument in support of Gegenbaur's view that the heart of Molluscs might be derived

\* Journ. Anat. et Physiol., A. 1894, pp. 147-88 (36 figs.). See Zool. Centralbl., i. (1894) pp. 513 and 4.

† Comptes Rendus, cxix. (1894) pp. 339 and 40.

‡ Tom. cit., pp. 354 and 5.

§ Morphol. Jahrb., xxi. (1894) pp. 28-39 (1 pl.).



from the dorsal vessel of worms. Haller describes some other features, such as the nerve-plexus on the stomach, but they are of less interest. He reiterates his previous conclusion that the Aplacophora are divergent forms which have lost gills, shell, &c., and become adaptively worm-like, degenerate rather than primitive.

#### δ. Lamellibranchiata.

**Eyes of *Cardium muticum*.**\*—Mr. K. Kishinouye has discovered eyes in this mollusc which can be easily found without a Microscope, as black spots on the siphonal side of the tip of a tentacle. All the essential parts of an eye are to be found, and there is a general resemblance to the eyes of *Pecten*, *Spondylus*, and *Cardium edule*. The cornea consists of thin pavement cells, and not, as in most Molluscs, of columnar cells. The lens is large, consists of a great number of cells, and is ovoid, not biconvex in form. The retina is in contact with and directly below the lens; it is very simple in structure, being formed of one layer of columnar cells. The rods are directed away from the retinophores and are separated from them by a false membrane. Below this are layers which are called choroid and tapetum, and, lastly, there is a layer of pigmented cells.

The eyes are innervated from the visceroparietal ganglia, and they appear to develop in two ways; both of these are abbreviated, but one is shorter than the other.

#### Molluscoidea.

##### α. Tunicata.

**Budding of Diplosomidæ and Didemnidæ.**†—M. M. Caullery lays emphasis upon the part which the epicardiac tubes play in the formation of buds. In *Diplosoma gelatinosum* Edw. these two tubes persist in the adult, separate from one another and from the branchial sac; their upper ends extend to near the level of the stomach, at their lower end the heart lies; their epithelium is in a state of continuous proliferation, except on the margin turned towards the interior of the intestinal loop. The author describes in detail how these two tubes take the chief share in forming the thoracic and abdominal buds, which fuse to form one individual. The interesting double origin is considered, thus the alimentary canal is formed from three independent rudiments:—the œsophagus, from the right epicardiac tube of the thoracic bud; the intestinal loop, as a diverticulum from the œsophagus of the parent; the rectum, from the rectum of the parent. The double origin is compared with what Salensky has observed as to the origin of two individuals from one ovum in Diplosomidæ.

**Synascidæ of Spitzbergen Expedition.**‡—Herr R. Gottschaldt gives an account of the Synascidians collected during the late Dr. A. Walter's expedition from Bremen. There were found *Botrylloides rugosum*, *Colella Kuekenenthalii*, *Leptoclinum structum*, *Goodsiria borealis* spp. nn., *Synœcum turgens* Phipps., and *Polyclinopsis Haeckeli* g. et sp. n. This

\* Journ. Coll. Sci. Imp. Univ. Japan, vi. (1894) pp. 279–85 (1 pl.).

† Comptes Rendus, cxix. (1894) pp. 437–9.

‡ Jenaische Zeitschr., xxviii. (1894) pp. 343–69 (2 pls.).

last is made the representative of a new family, the Polyclinopsidæ, which appear to occupy an isolated systematic position; while most allied to the Polyclinidæ, on account of the persons being divided into three regions, it is distinguished by having the gonads separate, and the testes not composed of racemose follicles. From the Distomidæ it is separated by the complete absence of ectodermal appendages and a stalk. With some resemblances they are distinguished by, *inter alia*, the presence of a post-abdomen and the regularity of the cormidia.

All the species are described in detail.

*Perophora annectens*.\*—In introducing this new species of American Tunicates, Mr. W. E. Ritter remarks that, though he believes it to be a *Perophora*, its chief characteristic would, with some of the schemes of Tunicate classification, lead to its being placed in a different suborder; this characteristic is the fact that in very many, though not in all, of the colonies the ascidiozooids are as completely imbedded in a common test as they are in *Botryllus* and *Goodsiria*. The author is of opinion that the distinction between "simple" and "compound" Ascidians, the importance of which has diminished in the same ratio that our knowledge of the group has increased, is reduced to nil by the discovery of this form; so far, that is, as its value in determining affinities is concerned. A detailed account is given of this new form.

#### Arthropoda.

Germinal Layers, Yolk Cells, and Embryonic Membranes of Arthropoda.†—Herr J. Wagner has been led from his embryological studies on mites and *Mysis* to some general conclusions. He begins by noticing the varied effects of the amount of yolk on cleavage and on the formation of layers. Thus the origin of the inner layer (meso-endoderm) by immigration, e. g. in Crustacea, is a secondary result. Comparing the early stages in the development of the Arthropod types, he concludes that Myriopods and Insects have been derived from Annelid-like ancestral forms with elongated blastopores, Crustaceans and Arachnoids from forms with round blastopores. Among Arachnoids, the mites show an original distinction between endoderm and mesoderm elements, and this is primitive. The yolk-cells of Crustaceans, Myriopods, and Insects represent a special type of vitellophagous elements, not derivable from ancestral forms; but those of Arachnoids are independent of those of other Arthropods, e. g. in showing a much earlier differentiation. The embryonic envelopes probably originated independently in the different groups: the insinking of the embryonic streak or imaginal plate depends on its sharp differentiation into covering cells and embryocytes. In fact, that invagination in some form must follow such differentiation is a general fact of development. The insinking of the embryonic streak leads to the formation of the envelopes; and they are subsequently cast off in consequence of the relatively more rapid growth of the embryonic portion.

\* Proc. Cal. Acad. Sci., iv. (1893) pp. 37-85 (3 pls.).

† Biol. Centralbl., xiv. (1894) pp. 361-75.

## α. Insecta.

**Temperature Experiments on Lepidoptera.\***—Mr. F. Merrifield has continued his experiments on the effects of temperature on Lepidoptera. These effects are different when applied at different periods of the pupal stage; there may be a great constitutional difference in sensitiveness to temperature between two seasonal emergences of the same species. In some, perhaps the most important, cases there is a reversion to some ancestral form, and here low temperatures produce one class of effects, and high temperatures a different class. The author is obviously correct in saying that the subject is one of much complication.

Dr. F. A. Dixey † discusses the bearing of these experiments on theories of Heredity.

**Comparative Morphology of Abdomen of Lampyridæ, Cantharidæ, and Malachiidæ.‡**—Dr. C. Verhoeff has based his study on the abdominal segments, copulatory organs, ovipositors and dorsal glands of these families of Coleoptera; and the essay is to be taken as a contribution to the phylogeny of the order, or class, as he calls it. He proposes a fresh classification, which will probably interest only the specialist, and concludes with some broader generalizations.

He finds that the presence or absence of a basal plate may be characteristic of a whole order, as may also be an oviposition-apparatus of definite structure. The presence or absence and the form of certain plates of the segments may hold for a whole family. The presence or absence of stigmata on the eighth segment may be characteristic of orders. Whole families may have a penis of definite structure. The fusion of parameres with one another, and their form may be of essentially the same character in the representatives of families and subfamilies; a special type of preputial sac may be found in one subfamily. Definite endoskeletal structures may hold for orders, families, or subfamilies. A definite differentiation or form of a basal plate may be typical for subfamilies.

**Absolute Force of Muscles.§**—Prof. L. Camerano has made a large number of experiments on the flexor muscles of the mandibles of Coleoptera, determining their absolute force. It does not seem to vary much with the weight of the insect, at least the relative variations do not appear to show any regularity. But individual variations are frequent, and the left flexor may be stronger than the right, or that of the female may excel that of the male. The strength varies with the nature of the food. An average value is expressed by 3432·59 gr., a maximum at 6915·89 gr., while for Crustaceans the corresponding figures are 1841·21 and 3203, for the frog 2000 and 3000, for bivalves 4545·79 and 12,431, and for man 7902 and 10,000.

**Male Reproductive Organs of Beetles.||**—Dr. K. Escherich describes the genital system in the males of *Carabus*, *Blaps*, and *Hydro-*

\* Trans. Entomol. Soc. Lond., 1894, pp. 425-38 (1 pl.); tom. cit., pp. 439-46.

† Tom. cit., pp. 439-46.

‡ Arch. f. Naturg., lx. (1894) pp. 129-210 (4 pls.).

§ Mem. R. Accad. Sci. Torino, xliii. (1893) pp. 229-60.

|| Zeitschr. f. wiss. Zool., lvii. (1894) pp. 620-41 (1 pl., 3 figs.).

*philus*. The Carabidæ illustrate the simplest state: a simple blind tube on each side produces spermatozoa, stores the elements, and secretes mucus; each tube opens into a somewhat stronger duct, and the two ducts unite in a common ejaculatory canal. The terminal portion in this case is lined with chitin, and is therefore ectodermic, not the result of the confluence of the mesodermic vasa deferentia. The regions corresponding to testes, vasa deferentia, and seminal vesicle are mesodermic, and Escherich calls them "primary sexual organs"; as "secondary" he distinguishes the ectodermic penis with its "parameres," the ejaculatory duct, and two tubular glands—the "ectadenia." Starting from such a simple case as *Carabus*, the author shows how the endless variety of complications may be reduced to some order, as illustrations of progressive specialization.

**Tertiary Rhynchophorous Coleoptera of the United States.\***—Mr. S. H. Scudder finds that the general faunas of this fauna is American, that all the species are extinct, and none common to the Gosiute lake and the basin of Florissant; no species is identical with any European Tertiary form. Indeed the Coleoptera appear to tell the same story as other groups of American Tertiary insects.† In the preparation of the monograph 753 specimens were examined.

**Seminal Receptacle of the Wasp.‡**—Dr. P. Marchal finds that this organ has three layers, an internal chitinous layer, a medium layer of elongated epithelial cells whose inner parts are striated, and an external layer of imperfectly striped muscle elements. The middle layer is particularly interesting, as an instance of epithelio-muscular cells.

As regards structure, the author differs from the late Mr. Cheshire, maintaining that the seminal canal, from the receptaculum to the vagina, is simple and not bifurcated.

He also describes the copulation. The males may copulate several times; a second copulation on the female's part is rare. No pairing can occur between the nearly related *Vespa germanica* and *V. vulgaris*. The epithelio-muscular cells, probably by a peristaltic movement, serve to draw up the seminal fluid. In the nests there are no special cells for the males, and it seems likely that the occurrence of males in the queen's progeny is due to a diminution in the amount of spermatic fluid.

**Fertile Workers among Bees.§**—Dr. P. Marchal discusses the occurrence of fertile workers, as alleged by several naturalists from Aristotle to Huber, but still doubted by such an authority as Prof. J. Pérez in his recent work on Bees. From a case furnished by M. Huillon, the author has convinced himself of the reality of the alleged occurrence. A queenless hive supplied many examples of workers with fully developed ovaries; the numerous eggs were laid with much irregularity (thus there might be ten in one cell); the progeny consisted of males. Dr. Marchal does not, of course, claim that his observations are novel, but they are useful as corroborations.

\* Monographs U.S. Geol. Survey, xxi. (1893) xi. and 206 pp., 12 pls.

† See *ante*, p. 446.

‡ Ann. Soc. Entomol. France, lxiii. (1894) pp. 44-9 (1 fig.).

§ Bull. Soc. Entomol. France, 1894, pp. cxcv-vii.



**Diptera destructive of Cereals.\***—Dr. P. Marchal notes that we are far from knowing all the Diptera which ruin cereals. Of those observed at the Paris Entomological Station in 1894 he records:—*Cecidomyia destructor* Say, *Cecidomyia (Diplosis) tritici* Kirb., *Oscinis pusilla*, *Chlorops*, *Camarota flavitarsis* Meig., and *Elachiptera cornuta* Meig.

**Anatomy of Phylloxeridæ.†**—Dr. L. Dreyfus has many criticisms to make as regards Krassiltschik's contributions to the classification and comparative anatomy of the Phytophthires. Dreyfus's subdivision of the Phytophthires into Coccidæ, Phylloxeridæ, Aphidæ, and Psyllidæ was adopted without due acknowledgment; a form nearly related to Psyllidæ must be taken as the starting point for the group of Phytophthires; the Phylloxeridæ are in many points degenerate, e.g. in the absence of Malpighian tubules. Furthermore, Dreyfus has to correct Krassiltschik's account of the structure of the suctorial apparatus, the salivary pump, the head framework and muscles, the tracheal system, the pseudo-vitellus and fat cells, the digestive organs, and so on. But, as Dr. Dreyfus says, it is hopeless to describe such things without diagrams.

**Larva of Oncodes.‡**—Herr A. König describes the larvæ of *Oncodes gibbosus*, or *O. zonatus*, one of the Acroceridæ. The larvæ have not been carefully described except in advanced stages, when they occur as endoparasites in the cocoons or bodies of spiders. They measured .3–.4 mm. in length, were dark brown, almost black, in colour, had eleven segments without a distinct head, and bore numerous bristles. The metapneustic respiratory system, the modification of the last segment for fixing and springing, and the complicated mouth-parts, are described.

**Heart of Orthoptera.§**—M. A. Kowalevsky states that, in addition to the venous clefts which open into the pericardial chamber, there are in the Orthoptera a series of openings by which the heart is put into direct communication with the circum-intestinal region of the cœlum. In *Pachytilus*, *Locusta* and others there are five pairs of openings, which are arranged symmetrically in the five abdominal segments in such a way that the cardiac chambers of these segments have each four openings—two by which they receive the blood of the pericardial region, and two by which they obtain that of the circum-intestinal region; all these openings are believed to be venous.

The apertures now described for the first time may be seen by the naked eye if the heart is looked at from below; it is proposed to call them cardio-cœlomic clefts to distinguish them from the long known cardio-pericardial clefts.

A remarkable discovery is the fact that a Malpighian tube penetrates into the heart by a cardio-cœlomic aperture, leaves by a cardio-pericardial aperture, and penetrates into the pericardial chamber.

### β. Myriopoda.

**Classification of Iulidæ.||**—Dr. C. Verhoeff proposes a revised classification of Iulidæ. He recognizes five genera:—*Micropodoiulus*

\* Comptes Rendus, cxix. (1894) pp. 496–9.

† Zool. Anzeig., xvii. (1894) pp. 205–8, 221–35, 237–43 (2 pls.).

‡ Verh. Zool.-bot. Ges. Wien, xlv. (1894) pp. 163–6 (1 pl.).

§ Comptes Rendus, cxix. (1894) pp. 409–11.

|| Verh. Zool.-bot. Ges. Wien, xlv. (1894) pp. 137–62 (2 pls., 6 figs.).

Verh.; *Iulus* s. str. with nine subgenera; *Pachyiulus* Verh. with two subgenera; *Palaioiulus* Verh. with three subgenera; and, lastly, *Tachypodoiulus* Verh. He gives an elaborate diagnostic table of the genera and species. For the collector north of the Alps he notes that the common forms are mostly species of *Iulus* s. str., besides which and the readily recognizable *Blaniulus* and *Isobates*, there are five species to be met with, *Micropodoiulus terrestris*, *M. terrestris*, *Tachypodoiulus albipes*, *Palaioiulus sabulosus*, and *P. mediterraneus*.

**Poison-Glands of Chilopoda.\***—M. O. Duboscq describes the structure of the poison-glands of *Scolopendra cingulata*; around the excretory canal, which consists of thick chitin, the glandular substance appears to be arranged, but the duct is morphologically superficial; the glandular substance is formed of numerous tubes, with a delicate basement membrane, with small cells in a state of active proliferation; so that each tube produces and contains a large quantity of poison. Among the tubes are numerous striated muscular fibres, and there is a well-developed muscular apparatus for the compression of the gland, and the expulsion of the poison. The structure is essentially the same in other Chilopods; *Cryptops*, *Geophilus*, *Lithobius*, and *Scutigera* have been examined.

#### 8. Arachnida.

**Development of Lungs of Spiders.†**—Mr. O. L. Simmons finds that the lungs of the Spider arise as infoldings upon the posterior surface of the appendages of the second abdominal somite, in the same way as the gills of *Limulus* (Kingsley). They have the same growing point, and form lung-leaves in the same way as the gill-leaves arise. The lung-books of the Spider, therefore, arise at first as an external structure on the posterior surface of the abdominal appendages; they sink in, without any inversion or other complications, in the way suggested as probable by Kingsley.

The tracheæ develop from the limbs of the third abdominal somite; in their earlier stages these appendages have on their posterior surface a folding similar to that on the member in front. The author concludes from this that the lung-book condition is the primitive, and that the tracheæ of the Arachnids are derived from it, and he advances the generalization that the facts adduced leave "no ground for those who regard the 'Tracheata' as a natural group of the Animal Kingdom."

**Cœlomic Cavity of Spider.‡**—Mr. K. Kishinouye has investigated various species of *Lycosa* and *Agalena*. He finds that, in the course of development, the cœlomic cavities in the segments of the chelicerae and pedipalps degenerate and disappear; the greater portion of the cœlomic cavities of the four ambulatory appendages degenerate, while the mesoderm cells that form their wall become gradually changed into muscles. The cœlomic cavity of the first ambulatory appendage communicates with the exterior by means of a duct of ectodermic origin. The formation of the dorsal circulatory system greatly resembles that of *Limulus*. Later on, the cœlomic cavities in the cephalothorax all disappear, except the small portions at the outer bases of the first to third ambulatory

\* Comptes Rendus, exix. (1894) pp. 352-4.

† Amer. Journ. Sci., xlviii. (1894) pp. 119-28 (1 pl.).

‡ Journ. Coll. Imp. Univ. Japan, vi. (1894) pp. 287-94 (1 pl.).

legs; these remnants fuse together, and form the coxal gland. In the abdomen, also, all the coelomic cavities disappear except the unpaired one in the caudal lobe, which remains as the stercoral pocket.

**Development of Scorpion.\***—Dr. A. Brauer has studied the development of *Enscorpius carpathicus* L. (younger stages) and *E. italicus* (older stages). The result of segmentation is a single-layered, circular or oval plate, with a more or less watchglass-like curve. The cells of this blastoderm are very small, and lie on the yolk at the pole towards the oviduct. They show considerable irregularity in arrangement.

An excentric white spot appears on the embryonic disc and gradually spreads over it; the blastoderm cells are dividing radially, and those next the yolk are Rhizopod-like with large nuclei and vacuoles. Most of these are yolk-cells, which, as others have shown, take no direct part in forming the embryo. But the thickened white spot also includes a group of cells which turn out to be genital cells and define the posterior end of the embryo. The first spindle-shaped endoderm cells are also detected between the yolk cells on the one hand, and the ectoderm or the genital rudiment on the other. There is ample reason to deny that the yolk cells share in the formation of this endoderm, and the reverse process is highly improbable. From proliferation of the ectoderm, especially in front and at the sides of the thickened region, the mesoderm arises. It will be noted that in the interpretation of the thickened area as the genital rudiment, and not as the rudiment of the ento-mesoderm, &c., Brauer differs from Kowalevsky, Schulgin, Metschnikoff, and Laurie. In regard to the formation of the embryonic envelopes, his results are in agreement with those of Laurie.

**Parthenogenesis in Plumicolous Sarcoptidæ.†**—M. E. Trouessart finds that *Syringobia chelopus*, a parasite in the feathers of *Totanus calidris*, has two female forms, one of which is sexual, while the other develops parthenogenetically. In the absence of males the developing female does not pass to the second nymph-stage, but grows to twice its usual size, and then changes after one ecdysis into a female which develops parthenogenetically. It lays soft eggs, whence emerge a series of larvæ and nymphs, different from those that are produced sexually, and ending in parthenogenetic females. Very rarely, and in the ratio of about 1 to 300, an extraordinary male appears, but this is sterile, for the female of this series has no copulatory orifice.

#### e. Crustacea.

**European and Chilian Crustacea.‡**—Dr. R. A. Philippi has noted some resemblances between the Crustacean fauna of Europe and Chili, which are, he thinks, something more than chance likenesses. To them, he says, are confined the genera *Lithodes*, *Atelecyclus*, and *Pirimela*. He finds an explanation in the hypothesis that similar, and perhaps even identical creatures, are found wherever similar conditions of life obtain.

**Reproduction of Lobster.§**—Mr. F. H. Herrick finds that many of the statements regarding the breeding habits of *Homarus americanus* are conflicting. With regard to the date of oviposition, most lobsters ex-

\* Zeitschr. f. wiss. Zool., lvii. (1894) pp. 402-32 (2 pls., 6 figs.).

† Bull. Soc. Entom. France, 1894, pp. cxvii.-xx. See Zool. Centralbl., i. (1894) pp. 639 and 40.

‡ Zool. Anzeig., xvii. (1894) pp. 264 and 5.

§ Tom. cit., pp. 289-92.



trude their eggs in June, July, and August, but at least ten per cent. lay eggs in other months of the year, and the process, though unusual, appears to be perfectly normal. Indeed it is possible that the like variability would be found to obtain in the case of other animals with a fairly definite breeding season, if they were minutely studied.

The law of production may be expressed thus: the numbers of eggs produced by female lobsters at each reproductive period vary in a geometrical series, while the lengths of the lobsters producing these eggs vary in an arithmetical series; thus:

Series of length: (in inches)	8	10	12	14	16
„ eggs	5,000	10,000	20,000	40,000	80,000

The eggs are carried, attached to the body of the female, for a period of from ten to eleven months; it is probable that the survival of two out of every 10,000 larvæ hatched is a high estimate.

**Conversion of Pagurinæ into Lithodinæ.\***—M. E. L. Bouvier remarks that though, at first sight, it is difficult to believe in the close relationship of *Lithodes* with the Hermit-Crabs, the researches of Boas have shown their affinities. Up till now, however, the mechanism of the change of the abdomen has not been explained, and it is his object to fill up this gap in our knowledge. He finds by a comparative research that the abdominal pieces of the Lithodinæ, though similar in position to the corresponding pieces of the Pagurinæ, have no real homology with them. To become typical Lithodinæ a *Eupagurus* must first lose all its abdominal pieces, with the exception of those of the first and two last segments. The vast membranous surface of the abdomen is then invaded by calcified nodules, and it is by the fusion of these nodules that all the solid pieces, which characterize the representatives of this subfamily, are alone formed.

**Subterranean Crustacea of New Zealand.†**—Dr. C. Chilton gives a detailed account of those interesting forms, to the existence of which he was the first to call attention, some eleven years since. This fauna is found to be peculiarly rich, and much more varied than that of either similar faunas in Europe or North America; so far as at present known, it consists of three species of Amphipods, and three of Isopods, belonging to five genera. Of these *Crangonyx* is already known from the subterranean waters of Europe and North America; one new genus, *Cruregens*, belongs to the Anthuridæ, a family of which no members were previously known to inhabit underground waters, while another, *Phreatoicus*, is so peculiar that it must form the type of a new family of Isopoda. Its affinities are discussed at some length, and the reasons for regarding it as an Isopod and not as an Amphipod are clearly given; on the whole, indeed, *Phreatoicus* is found to occupy a fairly central position among the Isopoda, as it retains to a greater extent than any other the typical characters of the order. An amended account is given of *Cruregens*; it is one of the Anthuridæ, and, as it has only six pairs of legs, it appears to permanently retain what is ordinarily a larval character in Isopods; it is remarkable among the Anthuridæ for having no palp to its mandible. *Crangonyx compactus* is remarkable for having only one ramus to the pleopoda, instead of the two which are almost universal in Amphipods.

\* Comptes Rendus, exix. (1894) pp. 350-2.

† Trans. Linn. Soc. Lond., vi. (1894) pp. 163-284 (8 pls.).



*Gammarus fragilis* has some characters by which it approaches the genus *Niphargus*.

The author next proceeds to discuss the general fauna of the subterranean waters of Canterbury; some small Gastropods, a small *Vorticella*, and the peculiar worm *Phreodrilus subterraneus*; the characters of the last call to mind the chief remarkable points in *Phreatoicus*. Passing to the Canterbury Plains and their underground waters, Dr. Chilton draws attention to the evidence that has now accumulated as to the universality and great extent of underground waters. It is rash to speculate, but it seems probable that all the subterranean forms adopted the same mode of life at about the same time, and that they are not now being reinforced by fresh immigrants from the surface. There are many resemblances between the deep water fauna of the sea and especially of freshwater lakes and the subterranean fauna.

The special characteristics of the subterranean fauna are considered under the heads of colour, loss of eyes, compensation for loss of eyes, food, arrested development, and habits, into the interesting details of which the limits of our space forbid us to enter.

Lastly, the author considers the bearings of the phenomena of subterranean life on the theory of descent, and gives weighty arguments in favour of the operation of Natural Selection, as against the Neo-Lamarckian views of Packard. The author, in the course of his studies on subterranean life, has been much impressed by the keenness of the struggle for existence, and how every spot on earth has been seized on; the small and apparently helpless Amphipoda and Isopoda are found not only on land and in the sea, in streams and ponds, in hot springs and frozen pools, on mountain-tops and in mines, burrowing in mud and boring into wood and stone, but in dark recesses "where no storm ruffles the everlasting stillness, no light illumines the thick darkness, and no sound breaks the eternal silence."

**Pelagic Schizopoda.**\*—Mr. A. Ortmann gives a list of the known species and descriptions of the new forms of pelagic Schizopods dredged by the 'Albatross' in the 1891 expedition; there are new species of *Thysanopoda*, *Euphausia*, and *Boreomysis*; a synopsis is given of the known species of the last of these genera; and there are some remarks on the vertical distribution of the Schizopoda.

**Caspian Crustacea.**†—Prof. G. O. Sars has commenced a series of papers on the Crustacea of the Caspian Sea, of which very little is as yet known; it is hoped that this study may throw much light on the supposed connection of the Caspian with other parts of the Ocean. The author believes that this fauna is derived from three very different sources; one part is of true Arctic origin, and constitutes the remnant of the primitive fauna which existed when there was, perhaps, a connection between the Caspian and Polar Seas. Another part is of a more southern character, and may have immigrated from the Black Sea and the Mediterranean. A third part consists of a number of true freshwater forms which have adapted themselves to living in somewhat brackish water. When the abyssal region of this sea comes to be explored it will be found to contain a fauna of purely Arctic character.

The first memoir deals with the Mysidæ, all the examples of which

\* Bull. Mus. Comp. Zool., xv. (1894) pp. 99-191 (1 pl.).

† Bull. Ac. Imp. St Pétersbourg, xxxvi. (1893) pp. 51-74 (8 pls.).

are Mysinae; four genera, one of which is new, and eight species are recognized; of these last four are not yet known beyond the Caspian, while four are stated to inhabit also the Black Sea. The new genus *Katamysis* (*K. Warpachowskyi* sp. n.) is chiefly distinguished by the very remarkable reduction of the terminal part of the four posterior pairs of pereopods, which look as if they had been mutilated.

In the second part\* of his report on the Crustacea of the Caspian Sea, Prof. G. O. Sars deals with the Cumacea. Contrary to expectation, the group is very well represented, and several of the forms are a good deal larger than their oceanic allies. Some have a most peculiar aspect, in consequence of the strange development of dorsal crests on the free segments of the mesosome. All the species belong to the genus *Pseudocuma*.

**Entomostraca from Gulf of Guinea.**†—Mr. T. Scott has a report on the Entomostraca obtained by Mr. J. Rattray in the Gulf of Guinea by net-gathering. One hundred and forty-eight species of Copepoda, two of Cladocera, and twenty-four of Ostracoda are enumerated; great variations were observed, and due note has been taken of them in establishing new genera and species.

**Ostracoda of Naples.**‡—Herr G. W. Müller has published a handsome report on the Ostracoda of Naples and the Mediterranean. The whole work is of the elaborate kind to which Dr. Dohrn has accustomed

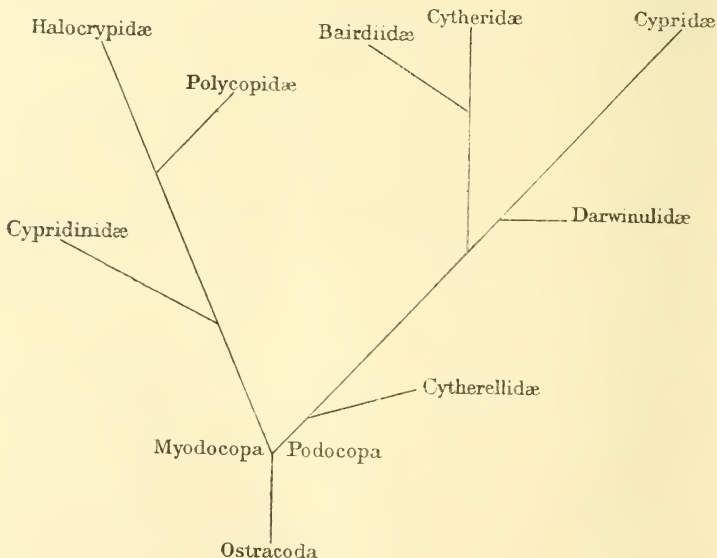

us, and there is, as usual, a great wealth of illustration. On the whole, Sars' division of the order into the Myodocopa and the Podocopa is

\* Tom. cit. (1894) pp. 297-338 (12 pls.).

† Trans. Linn. Soc. Lond., vi. (1894) pp. 1-161 (15 pls.).

‡ Fauna u. Flora des Golfes von Neapel, xxi. Monogr. Ostracoden, Berlin, 4to, 1894, vi. and 404 pp. (40 pls.).

accepted, and the relations of the families are shown by the annexed table.

**Metamorphosis of Freshwater Ostracoda.\***—Prof. C. Claus finds that the Ostracoda undergo a metamorphosis, for not only have they, at different stages of their free life, a different form of shell, but they exhibit differences in the number and form of their appendages, and they have several provisional arrangements. In *Cypris* nine successive stages are to be distinguished. The youngest larva is a shell-bearing Nauplius-larva, with the three anterior pairs of appendages, the third of which is not a mandible, but a leg. It is not till the second stage that the mandibles take on their definite form, and the leg then becomes a mandibular palp. At the same stage there appear the "Anlage" of the maxillæ, and the furcal stump with its hooks. The second pair of maxillæ appear in the fourth stage, and come into function in the fifth. The position and insertion of the hinder tuft of hooks, which is present in all stages of development, undergo several changes, for at first it is borne by the second pair of maxillæ, then by the furcal stump, then by the maxillip, and finally (and permanently) by the anterior pair of legs.

The hinder pair of legs appears in the sixth stage; in the seventh all the appendages have their permanent conformation, and in it the first signs of the generative organs become apparent; their further development and sexual differentiation occur in the eighth stage. The so-called abdomen or post-abdomen is the furca, and is first seen in the second stage. In the fifth the hepatic tubes grow into the shell. The Ostracoda have a kind of shell-gland. The setal appendages of the shell are connected with a system of fine threads and cells.

**A Flying Copepod.†**—Dr. A. Astroumoff reports that, one morning early, with a calm sea and clear sky, he saw a number of the small green *Pontellina mediterranea* rise from the water, make springs in the air, describe a long curve, and fall again into the sea. This unusual mode of locomotion is effected by the strongly pinnate limbs, and has probably some connection with the commencement of the process of ecdysis.

#### Vermes.

**Cerebral Physiology of Worms.‡**—Dr. J. Loeb finds that if *Thysanozoon Brocchii* be cut across transversely the anterior half moves spontaneously, but the posterior half has to be stimulated. If instead of making this cross cut the longitudinal nerves are cut through, the two pieces being left connected on one side by a thin bridge of substance, the aboral piece continues to take a co-ordinated share in progressive movement; alterations of movements start, however, only from the oral piece, and are only after some time communicated to the aboral piece.

If *Planaria torva* be cut across, the aboral half, which contains no brain, moves quite as fast as the oral half. Increase of intensity of light stirs the normal animal to movement, and this peculiarity may be seen in the separate hinder pieces. The hinder separated half of *Cerebratulus marginatus* does not, like the anterior half, try and bore in the sand.

If a *Nereis* be cut into several pieces it is the oral part only that is

\* Zool. Anzeig., xvii. (1894) pp. 325-30.

† Tom. cit., p. 369.

‡ Arch. Ges. Physiol., lvi. pp. 249-69. See Zool. Centralbl., i. (1894) pp. 554-6.

able to bore into the sand. Progressive movements are begun by the other pieces if they are stimulated.

The author concludes that in Worms, as in higher animals, it is the anterior end, provided with the brain, that chiefly defines the biological and physiological character of the species; there is no consciousness in Worms, and there is no parallelism between the cerebral formation of the several species and their systematic position.

#### a. Annelida.

**Polychæta of Dinard.\***—M. le Baron de St. Joseph commences the third part of his account of the Polychæta of the coasts of Dinard with a description of *Nephtlys* and its allies. The rare *Glycera gigantea*, which is 28 to 30 cm. long, was found only once. *Goniada emerita* was likewise only found once, and the specimen was incomplete. It is thought best to keep *Ephesia* distinct from *Sphærodorum*; *E. peripatus* is very rare at Dinard. The Cirratulidæ are divided into those with and those without large prehensile tentacles, and some suggestions are made as to the redistribution of the genera. The characters of *Heterocirrus* are emended, and *H. caput esocis*, *H. flavoviridis*, and *H. Marionii* spp. n., are described.

The granitic rocks of Dinard are unsuitable for the Polydoridæ, which can only hollow out their homes in calcareous rocks; *P. pusilla* is a new species. An account is given of various larvæ of *Nerine*. The complete description given by McIntosh of *Magelona papillicornis* makes it unnecessary to describe this species at the length devoted to most of the species mentioned in this memoir.

The Scalibregmidæ may be divided into those with and those without gills; the characters of *Sclerocheilus* are emended. *Lipobranchus intermedius* is a new species, with affinities to *Sclerocheilus*. *Armandia Dollfusi* sp. n. is described from a single example, but appears to be distinct from the species already known.

The "synonymy" of *Arenicola marina* extends over nearly two pages; the largest examples are 25 cm. long. A new classification is proposed for the Maldanidæ, and the characters of some of the genera are emended, while a short diagnosis is given of *Maldanella*, which was not defined by its author, Prof. McIntosh. *Maldane* (?) *cineta* sp. n. is, perhaps, a *Maldanella*.

There is a long and detailed discussion of the characters of the Terebellidæ, and classification of the genera is proposed; of these *Pherea*, *Bathya*, *Proclea*, *Phisidia* are new. The Serpulidæ are somewhat similarly treated, *Erato* being the only new genus.

**Septal Glands of Oligochæta.†**—Dr. R. Hesse finds an essential agreement in the composition of the septal glands of various Enchytræidæ, of *Tubifex*, *Psammoryctes*, *Limnodrilus*, and *Lumbriculus*, so that he concludes that in all Oligochæta these septal glands are bundles of unicellular glands. The separate gland-cells are altered cells of the pharyngeal epithelium, which, by an extraordinary elongation of their distal ends, have separated from this epithelium, and have grown into

\* Ann. Sci. Nat., xvii. (1894) pp. 1-395 (13 pls.).

† Zool. Anzeig., xvii. (1894) pp. 317-21 (1 fig.).



the three or four somites which succeed the pharyngeal segment. The bundles of gland-cells are invested by a peritoneal epithelium.

**New or little-known Oligochæta.\***—Mr. F. E. Beddard describes three new species, and has some notes on *Henlea ventriculosa* and *Cryptodrilus spatulifer*. The author proposes to merge his genus *Rhododrilus* in Rosa's *Microscolex*, and offers an emended definition of the genus. *Pontodrilus hesperidum* sp. n., from Jamaica, is a representative of a family that has, so far as is known, but few species in the New World. *Henlea ventriculosa* is shown to have a very wide geographical range. *Fridericia antarctica* sp. n. is a long thin Enechytræid from New Zealand, remarkable for the presence in the three segments behind the male pores of sensory papillæ connected with specialized regions of the nerve-cord.

**Revision of Lumbricidæ.†**—Dr. D. Rosa recognizes four genera:—*Lumbricus*, with six certain species, *Allolobophora* with forty-nine, *Allurus* with six, and *Criodrilus* with one. The memoir contains a general account of Lumbricidæ, diagnoses of the genera and species, lists of doubtful and spurious species, and the like. Its importance to systematists is obvious. The plates noted in the reference are diagrammatic expressions of the position of the clitellum and tubercula pubertatis in the species of *Allolobophora*.

**Eye of Leech.‡**—Miss H. B. Merrill has studied the eyes of various Leeches and finds that Whitman's discovery of tactile and visual cells in the eye of *Clepsine* may be extended to other genera; the visual cells are arranged in a single layer round the axial nerve-fibres, except on one side, where the layer may be two or three cells thick. These cells contain a large crescentic vacuole surrounded by a layer of protoplasm, in the most thickened part of which is the small nucleus; and they are surrounded by the pigment layer. This last is made up of a single layer of small quadrangular cells, and outside it is a layer of connective tissue. The tactile cells are found at an opening on the upper part of the eye; over the top and at the side of the pigment cap the epidermal cells become elongated to two or three times their normal length; they are probably provided with sense hairs, similar to those found by Whitman in *Clepsine* and *Nephelis*.

**Efferent Canal of Glossiphonidæ.§**—M. H. Bolsius finds that the common efferent duct of these Leeches is dorsal in position, and that the testes are suspended to it; it communicates by a funnel with the testes, on the inner surface of which it is spread out; there is no special muscular apparatus for closing the duct or the testis.

**Gill-like Organs of Sipunculus.||**—Dr. W. Fischer, after calling attention to the doubts raised as to the once generally accepted view that the tentacles of Sipunculids are respiratory organs, describes the presence, on the mid-body of *Sipunculus mundanus*, of long villiform processes of the skin. These contain tegumentary spaces, and have a

\* Proc. R. Phys. Soc. Edinb., 1892-3 (1893) pp. 30-45 (3 figs.).

† Mem. R. Accad. Sci. Torino, xliii. (1893) pp. 399-476 (2 pls.).

‡ Zool. Anzeig., xvii. (1894) pp. 286-8 (1 fig.).

§ Tom. cit., pp. 292-5 (2 figs.).

|| Tom. cit., pp. 333-5.

very thin skin, so that he takes them for gill-like organs. Somewhat similar structures are to be found in *S. australis*.

### β. Nemathelminthes.

Development of Organs in Gordiida.\*—Prof. F. Vejdovský has studied *G. æstivalis* and *Gordius Preslii* (from *Feronia vulgaris*), *G. Væteri* (also from a beetle), and *G. pustulosus*. The main object of his investigation is to show how not only the organs, but their components, pass through metamorphoses in the course of development.

Thus, the well-developed, luxuriant hypodermis of the young becomes a flattened meagre layer in the adults. It degenerates in giving origin, first to the outer cuticula, which consists of extremely fine fibrils, and secondly to the distinct subcuticula with larger fibres. The fibrillation of the subcuticula is most probably due to a modification of the reticulum or so-called spongioplasm. The absence of a circular muscle-layer may be correlated with the fact that the hypodermis is certainly a muscle-epithelium.

The origin of the epithelial layer, which gives rise to the longitudinal muscles, remains unknown. There are two layers of "mesodermic" cells beneath the hypodermis; the one forms the longitudinal muscle-layer, the other is often called "parenchyma," though it is a genuine peritoneum lining the body-cavity. The muscle-cells are much flattened; the sarcoplasm or medullary substance is hyaline and homogeneous; the contractile substance runs on both sides of the cell and surrounds the pole towards the body-cavity, and there are fine bridges between adjacent muscle-plates; the muscle-plate itself consists of refractive corpuscles, and their arrangement gives rise to longitudinal and transverse striation.

The young forms show a true body-cavity, and the epithelial covering of the muscular layer is the peritoneum; the parenchyma or cellular tissue which is present posteriorly even in the young, and accumulates anteriorly into the adult, certainly arises from free lymphoid cells.

As to the nervous system, Vejdovský inclines to believe that the adult system is independent of the larval, for it is very late in appearing, and begins at a considerable distance from the end where the residue of the larval body is found. The ventral strand of the young is wholly due to a hypodermic thickening, and one of the author's most important results is that the so-called cerebral ganglion is only a continuation and paired swelling of the ventral strand. Strictly speaking, there is no cerebral ganglion nor œsophageal commissure, and histologically this is corroborated by the absence of the ganglion-cells in the paired swelling referred to. In the ventral strand there are three reticular strands, with unpaired ganglion-cells and unpaired lateral nerves, while in Lumbricidæ there are six reticular strands, with paired ganglion cells or groups of cells, and paired lateral nerves.

In connection with the food-canal the author shows that the "brown gland" opens into the œsophagus, and that the hypoblast cells form, like the hypodermis, a muscle-epithelium.

There are considerable differences, both individual and specific, in

\* Zeitschr. f. wiss. Zool., lvii. (1894) pp. 642-703 (4 pls., 3 figs.).

the development of the reproductive organs, and in the time at which the elements differentiate. Their first appearance remains unknown. There are interesting nuclear changes in the spermatogonia; without kinetic division the nuclear threads fall into four chromosomes, and each of these forms a new nucleus. It seems that the germinal epithelium is at first confined to small organs, and that the voluminous tubes ("sperm-sacs," not "testes") are secondary. So in the female, the original tubes with germinal epithelium give rise, by lateral paired evaginations, to the long uterine tubes, into which the ripe eggs of the adult return. But these are only a few of the results which Vejdosvsky has reached.

**Muscular Cells of Ascaris.\***—MM. G. Gilson and J. Pantel describe a prerectal sphincter muscle in *Ascaris* which is remarkable for being unicellular; the cell has the form of a closed ring, and the protoplasmic contents are only very incompletely differentiated into muscular substance; externally there is a layer of non-differentiated protoplasm, in which lies the nucleus. The musculature antagonistic to the sphincter, varies a little in different species; in *A. megalocephala* two cells, remarkable for the prolongations by which they come into manifold relations with neighbouring organs, function as dilatator muscles of the intestine, and as elevators of the pad which projects into the rectum. The whole forms an irregular ring, whence a number of prolongations are given off, most of which are more or less radial in direction. As the authors can find only two nuclei in this complex system, they are led to consider that it is made of only two cells.

The powerful musculature of the ejaculatory canal is formed by prolongations sent out by the "bursal fibres" of a definite region. These anastomosing prolongations are undoubtedly muscular in nature.

**Helminthological Notes.†**—Dr. A. Mueller begins with an account of *Filaria (Spiroptera) gastrophila* sp. n. (?) found projecting from the walls of a cat's stomach; this would appear to be the first *Filaria* found in a cat. *Strongyluris brevicaudata* sp. n. from a West African Lizard (*Agama colonum*) would appear to be a new generic type, allied to *Oxyuris* and *Leptodera* on the one hand and to *Strongylus* on the other. *Echinorhynchus pristis* and *E. annulatus* have been found in species of *Exocoetus*; and *Distoma segmentatum* is a new species from the small intestine of *Vidua paradisica*. Several partly known species are also described.

#### γ. Platyhelminthes.

**Asexual Reproduction in Freshwater Turbellaria.‡**—Herr J. Keller has made a study of various Turbellaria, in which he finds that the mode of asexual reproduction is of the kind called paratomy, or division accompanied by the formation of organs; there is no budding in this class. The various forms of asexual reproduction in it may be classified thus:

a. Paratomy with regeneration of complete parts of the body;

(1) With deferred formation of organs, e. g. *Planaria albissima*.

(2) With simultaneous formation of organs,

e. g. *Planaria subtentaculata*.

\* Anat. Anzeig., ix. (1894) pp. 724-7 (2 figs.).

† Arch. f. Naturg., lx. (1894) pp. 113-28 (1 pl.).

‡ Jenaische Zeitschr., xxviii. (1894) pp. 370-407 (4 pls.).





'' In the digestive apparatus a large muscular pharynx and a stomach can be distinguished; there is no true buccal cavity, and no pharyngeal pouch. The pharynx is divided into three parts by a median girdle of numerous unicellular glands, which pour their secretion into its lumen. The stomach is so constricted as to consist of a right and a left lobe, which are connected by a broad transverse band. The nucleus of the gastric cells is of considerable size.

Various other details as to structure are given, and, throughout, comparison is carefully made with Weber's description of *T. Semperi*.

**Monograph on Distomum.\***—Dr. A. Looss gives a monographic account of the structure and development of this genus, based on the study of 13 species, six from Fishes (including *D. isoporum* sp. n.) and seven from Frogs (including *D. confusum* sp. n.). He describes the structure and development of the skin, alimentary canal, nervous system, excretory apparatus, and in greatest detail the reproductive organs. As a mere instance of his work, we may refer to his discussion of the Laurer canal. He shows that it has no connection with impregnation, but functions as an efferent canal especially for the unused spermatozoa. The uterus of *Distomum* with its terminal vaginal portion corresponds to the vagina of tapeworms, and the uterus of the latter, in spite of the different position of the apertures, is homologous with the Laurer canal.

**New Human Tape-Worm.†**—Profs. I. Iijima and T. Kurimoto describe a new species of *Bothriocephalus* found in Man, which is very large, and is remarkable for being furnished with double genital ducts and openings in each proglottis. It is closely allied to, if not identical with, one of the species already described from Seals; in support of this view it is noted that the patient who discharged it resided continually at the sea-side. This patient suffered from general ill-health, on which gradual anæmia supervened. A dose of male fern resulted in the discharge of a tapeworm 10 metres in length, and, at its broadest, 25 mm. in breadth. Immediately after its discharge, it is hardly necessary to add, "all the complaints the man had suffered from for so many years entirely disappeared." The authors add notes on their examination of various proglottids.

**Tænia nana and flavopunctata.‡**—Dr. A. Lutz records a case of *Tænia flavopunctata* which occurred in Brazil. The patient was a child two years old who evacuated the head and tail of a small tapeworm. This had four suckers, between which lay a pretty large rostellum devoid of hooklets. The number of joints was about 960, of which some were sterile. The last proglottides were quite full of eggs. The worm was identified as *T. flavopunctata* (*Hymenolepis*, Weiland). The author agrees with Grassi that the usual host of this species is the rat.

The author also met with *T. nana* in a young child which passed pieces of tapeworm having on the average about 190 joints; the eggs were oval, of variable size, and showed papillæ at the poles. The head was not found.

\* Bibliotheca Zoologica (Leuckart and Chun) Heft xvi. (1894) pp. 236 (9 pls.).

† Journ. Coll. Sci. Imp. Univ. Japan, vi. (1894) pp. 371-86 (1 pl.).

‡ Centralbl. f. Bakteriol. u. Parasitenk., xiv. (1894) pp. 61-7.

Growth of *Tænia mediocanellata*.\*—From observations made in cases of Tapeworm (*Tænia mediocanellata*) Prof. E. Perroncito was enabled to determine that the average growth amounted to thirteen proglottides a day, both for the ripe and unripe parasite. In the latter case the increase in length would be almost less than half. This shows that the maximum length-growth and general development occurs in the second month, so that while there is in the first month a daily average increase of 3 cm. in length, in the second it amounts to 14 cm. a day, while the size of the individual joints is augmented in all directions.

#### Echinoderma.

Echinoderms of Eastern Seas.†—Prof. F. Jeffrey Bell gives an account of the Echinoderms collected during the voyage of H.M.S. 'Penguin' and by H.M.S. 'Egeria,' when surveying Macclesfield Bank. The species are enumerated under three heads:—(1) N.W. Australia, (2) Arafura and Banda Seas, (3) Macclesfield Bank. The author states that the collection is remarkable for containing a large proportion of young specimens, and that in some cases the series have been sufficiently long and gradual to enable him to assign quite young examples to what appear to be their correct species; the conviction has been forced on him that Macclesfield Bank is a nursery, and he suggests that as full collections as possible should always be made in areas resembling the inside of this reef, as among other advantages, material may be collected which is of immense value to the morphologist.

The point of greatest interest with regard to this collection is the discovery that the syzygial joints at the bases of the arms of Comatulids by no means exhibit the regularity which is ordinarily believed to be one of their chief characteristics. A discovery of great importance is that of a quite new type of Ophiurid, represented unfortunately by a single specimen; in *Ophiocrene ænigma*, as Prof. Bell calls it, we have an Ophiurid with branching arms and the habit of an Astrophytid, but with calycinal plates on the disc, and rounded radial shields of comparatively small size; the two halves of the oral apparatus, at each mouth-angle, are very distinct, and this, among others, must be supposed to be a primitive character.

The group Holothurioidea is remarkable for its almost total absence from the collection, and Mr. Bassett-Smith, Surgeon R.N., who formed the collection, was much struck by this. Of the Crinoids a new species is added to the rare and remarkable genus *Eudiocrinus*; in *Antedon Bassett-Smithi* we have, in one and the same specimen, arms with syzygies uniting the first and second brachials, or a syzygy on the third, or on both first and second, and third. Not only have we two conditions which were supposed by Carpenter to be mutually exclusive in different arms of one specimen, but these very two conditions occur on one arm. Attention is called to the *Brisinga*-like appearance of *Asterias volsellata*, and the view of Sladen that it diminishes the gap between the Asteriidae and the Brisingidae is accepted. There were in the collection numerous examples of the genus *Ophiothrix*, and reasons are given for

\* Centralbl. f. Bakteriol. u. Parasitenk., xv. (1894) pp. 800-1.

† Proc. Zool. Soc. Lond., 1894, pp. 392-413 (5 pls.).

refraining from naming any of them as "new species"; to work out a collection of *Ophiotriches* almost unlimited leisure is necessary. Reasons are given for supposing that colour must be considered as an unreliable aid.

One of Mr. Bassett-Smith's best finds was a fairly large supply of the interesting *Ophiopteron elegans* described by Prof. Ludwig in 1888, in which the arm-spines are connected by a membrane, so that they seem to form a kind of wing.

Throughout the paper there are scattered references to the theory, now a little discredited, as to the homologies of the calycinal plates of Crinoids with the apical plates of other Echinoderms; the test of a young *Culeita* only 12 mm. in diameter has been carefully mapped out with the hope of getting some light on the morphology of the skeleton, but in this the author confesses himself disappointed.

**Illustrations of Indian Echinoderms.\***—Under the authority of the Director of the Royal Indian Marine, and the direction of Dr. A. Alcock, the first part of the atlas of figures of Echinoderms described recently from the Bay of Bengal has lately been published. The three plates which have appeared are devoted to Asteroidea.

**Asteroidea.†**—Prof. H. Ludwig is to devote the second volume of his work on Echinoderma to the Asteroidea, and has just published the first two parts. The bibliographical list, which appears to be quite up to date and exceptionally well done, includes nearly six hundred titles. The history of our knowledge of the group is rapidly but adequately sketched, and the author then enters on an account of the morphology of the class. The form, the size, the colour, the external consistency are first dealt with. In treating of the skin, its layers and glands are described. Of the dermal appendages the most important are the pedicellariæ, which are divided into those that are stalked and those that are sessile; the former are either crossed or straight, and the latter forceps-like or alveolar. The cribriform organs of Sladen are thought to be morphologically identical with the ciliated spines of the *Astropectinidæ*, for they have essentially the same structure, and in all cases are placed on the vertical sutures of the marginal plates.

In his account of the skeleton Prof. Ludwig thinks it best to avoid the use of terms which indicate homologies to parts of the Crinoid or Echinoid skeleton, such as "basalia" or "calicinalia," and he uses strictly objective terms; thus the ambulacral skeleton consists of ambulacral, adambulacral and superambulacral pieces, and the region of the mouth is called the peristome. The interambulacral skeleton consists of the inner intermediate piece, the ventro-lateral and the lower marginal plates, while the antiambulacral skeleton consists of the upper marginal plates, the terminals, the primary plates of the back of the disc, the secondary radial plates of the arms and disc, the dorso-lateral, supplementary, and madreporic plates.

**Mesozoic Echinoderma of the United States.‡**—Mr. W. B. Clark, in continuation of the valuable work of Messrs. Wachsmuth and

\* 'Illustrations of the Zoology of the Royal Indian Marine Surveying Steamer Investigator . . . Echinoderma,' I. pls. i.-iii. Calcutta. 4to, 1894.

† Bronn's Klassen u. Ordnungen, II. 3, parts 17 and 18 (1894) pp. 461-540 (6 figs.).

‡ Bull. U.S. Geol. Survey, No. 97 (1893) 101 pp. and 50 pls.



Springer on Palæozoic Echinoderms, has prepared a report on the Mesozoic forms: he is convinced that further study will show that many of the North and South American forms will be found to be identical, but the identity of American with European species seems doubtful.

#### Cœlentera.

**Revision of Alcyonaria Stolonifera.\***—Prof. S. J. Hickson, in offering a revision of the genera of this group of Alcyonarians, prefaces it with some remarks on the reception (or rather want of it) given to his proposal, made in 1883, that those Alcyonaria in which the polypes spring independently from a basal stolon should be separated as a special sub-order, the Stolonifera. The order Alcyonaria is divisible into the Protoalcyonaria or solitary forms, Stolonifera, Alcyonacea, Gorgonacea, and Pennatulacea. The Stolonifera are Colonial forms, with a membranous or ribbon-like stolon; mesogloea poorly developed; polyps either entirely free from one another except at their bases, or connected by horizontal platforms (*Tubipora*) or connecting tubes (*Clavularia*). The skeleton is composed of calcareous spicules, which may be joined together, free or absent. The group contains the Tubiporidae and the Clavulariidae, the latter being represented by *Clavularia*, *Cornularia*, *Stereosoma* g. n. and *Symphodium*, with possibly the fossil *Syringopora*; this family Clavulariidae is practically the same as the Cornulariidae of other authors, and reasons are given for proposing the change of name.

In the family Cornulariidae the authors of the 'Challenger' Report on the Alcyonaria included sixteen genera, and some severe remarks are offered on the way in which their work was done.

The new genus *Stereosoma* is established for *S. celebense* sp. n., which is remarkable for the absence of contractility, and the separation of the tentacles from one another by very considerable intervals. The want of contractility is not due to the presence of spicules, for there are none, but to a tough, vacuolated, homogeneous substance lying above the mesogloea. *Clavularia garciæ*, *C. reptans*, and *C. celebensis* are new species, of which, as of some already described forms, accounts are given. The coloured plates illustrating this memoir are of peculiar beauty.

**Heliopora cærulea.†**—Mr. G. C. Bourne publishes an abstract of a memoir on the structure and affinities of *H. cærulea*, with some observations on *Xenia* and *Heteroxenia*. It is found that the cuticles and cœnenchymal tubes of *Heliopora* have not each their distinct and proper wall, but that the walls are common to them and to adjacent tubes; this genus and its allies may therefore be distinguished as the Cœnothecalia from forms like *Tubipora*, which are Autothecalia, or have each corallite separate and distinct.

*Heliopora* is not the only Alcyonarian that has a distinct ectodermic skeleton, for *Xenia* and *Heteroxenia* have a spicular ectodermic skeleton. In the Xeniiidae, as in the Helioporidae, most of the cœnenchymal mesogloea and the whole of the calcigenous elements are derived from the

\* Trans. Zool. Soc. Lond., xiii. (1894) pp. 325-47 (6 pls.).

† Proc. Roy. Soc. Lond., lvi. (1894) pp. 299-303.



ectoderm. In the one case the mesogloæal elements preponderate greatly over the calcigenous, in the other the preponderance of the calcigenous elements has led to the formation of a dense calcareous skeleton, the mesogloæal elements being reduced to a very subordinate position.

**Callirhabdos.\***—Dr. R. A. Philippi describes, under this name, a new genus of Gorgonids, which has, in the opinion of the editor—Prof. Hilgendorf—considerable general resemblance to Studer's *Primnoella magelhaensica*. The account is too short to allow of a definite judgment.

**Budding of Hydroids.†**—Dr. A. Lang published some time ago the results of his observations on the budding of *Hydra*, *Eudendrium*, and *Plumularia*, which seemed to show that the bud was to begin with wholly derived from the ectoderm. His observations have been contested by Herr F. Braem, and ‡ now Lang answers the criticism and reaffirms his conclusions.

#### Porifera.

**Tetractinellidæ of Naples.§**—Dr. G. C. J. Vosmaer returns to the point on which, as he says, he has often insisted that species vary greatly. For example, *Geodia gigas* may be regular or very irregular in form, with a smooth or rough surface, and the ovum vary in length and diameter. *Isops maculosus* sp. n. is spherical, globular, ellipsoid, or oviform. *Synops anceps* is irregular in form, and has a varying number of procts. Though the skeleton of *Caminus vulcani* exhibits an unmistakable degeneration from the tetraxile type, the specimens which the author examined possess more tetraxile spicules, and less deformities than the type-specimens of Schmidt. *Stryphnus mucronatus* and *S. carbonarius* are shown to be identical. Two new species of *Pacillastra*—*P. fragilis*, the substance of which resembles bread-crumbs, and *P. cumana*, which is like the leaf of a water-lily—are described.

**New Hexactinellids from Sagami Bay.||**—Dr. I. Ijima has a preliminary notice of some new, and in many cases truly magnificent forms of Hexactinellidæ. *Euplectella imperialis* may measure nearly 500 mm. in the portion exposed above the sea-bottom; it was taken from depths of 200–300 fathoms. *Hyalonema reflexum* will perhaps be found to require a new genus; *H. Owstoni*, *H. clathratum*, and *H. pellucidum* were taken at various depths between 200 and 400 fathoms.

#### Protozoa.

**Cell-granules in Protozoa.¶**—Miss M. Przesmycki has studied these in Ciliata, e. g. *Paramæcium*, *Colpidium*, *Opalina*. There are two sets, those which occur in vacuoles and those which lie in the cytoplasm. Some of the latter correspond to Altmann's granulæ, but the investigator finds no reason to regard them as elemental constituents of the cell or for comparing the structure of Protozoa to "a kind of zooglœa."

\* Arch. f. Naturg., lx. (1894) pp. 211–3 (2 figs.).

† Biol. Centralbl., xiv. (1894) pp. 682–7.

‡ Tom. cit., pp. 140–61.

§ Tijdschr. Nederl. Dierk. Vereen., iv. (1894) pp. 269–86.

|| Zool. Anzeig., xvii. (1894) pp. 365–9.

¶ Biol. Centralbl., xiv. (1894) pp. 620–6.

Parasite of *Perophora annectens*.\*—Mr. W. E. Ritter gives a short account of an interesting tentaculiferous Infusorian found parasitic on the tentacles and near the peripharyngeal band of this new species of Ascidian. It is impossible as yet to be certain of its affinities, but it is probable that they are rather with *Podophrya* than with *Sphærophrya*.

Morbific Effect of certain *Vorticellæ*.†—According to Herr Lindner there is a variety of stemless *Vorticella* found on the hairy scalp of man and the hair of some animals which produces irritating eruptions. This is called *V. ascoidium*, and has been cultivated in bouillon, blood-serum, milk, &c.

The author has also found similar stemless *Vorticellæ* in the secretion of respiratory mucosa, in the stools of typhoid patients, and in canal water, and he is disposed to consider them a variety of *V. microstoma*. In decomposing matter these Ciliata have their chief breeding places.

*Vorticella* germs can be kept for a month, either dry or moist, without losing their vitality and power of development. The author smeared a dog with vorticella fluid. This produced itching, and the dog after licking the surface took ill with fever, diarrhœa, and much distension. Three days after the dog died. Cultivations were made from the blood and from the feces in meat extract solution. From the blood, living *Vorticellæ* developed in a few days, while the cultivations from the faces were negative.

Growth of *Euglena* confined to two dimensions of space.‡—Dr. J. A. Ryder has been engaged in observations on specimens of *Euglena viridis* growing for several weeks in a Maupas moist-chamber on a slide under a cover-glass; the result of this condition of restraint was that nearly all of the planes of the first segmentations, after quiescence or encystation, had to proceed as if forced to adjust themselves at right angles to the plane of the narrow, flat space in which the organisms were confined. They were found to multiply in four ways:—(1) There was direct fission of the free-swimming, flagellate, adult organism; (2) The adult passed into a round resting-spore stage, which grew and segmented without a gelatinous envelope, and eventually produced an adult; (3) The adult passed into a round resting-spore stage, which after growth and segmentation produced a gelatinous envelope; this eventually deliquesced, and very small flagellate young escaped; (4) The adult passed into a resting-spore stage or a free-swimming spore germiniparous condition, in which a large endoplast was developed; from this a large number of exceedingly minute flagellate germs escaped; these grew and became creeping amoeboid forms, which eventually grew into adult *Euglenæ*.

The second and third of these methods do not seem to have been hitherto described; the second is especially interesting as some of the forms of cleavage it manifests under restraint to two dimensions of space

\* Proc. Cal. Acad. Sci., iv. (1893) pp. 57-9 (2 figs.).

† Deutsche Med. Zeit., 1894, p. 587. See Centralbl. f. Bakteriol. u. Parasitenk., xvi. (1894) p. 535.

‡ Contrib. Zool. Lab. Univ. Pennsylvania, i. (1893) pp. 37-50 (1 pl.).

seem to resemble the process of segmentation in the blastoderm of a fish-egg. Now, what has been abnormally achieved with *E. viridis* is achieved normally with the segmenting blastoderms of many Vertebrates and Invertebrates. In them growth proceeds over the spherical surface of the yolk under constraint mainly to two dimensions of space.

The singular fact that the side where the embryo is formed ultimately often grows slowest is probably to be explained by the blastoderm being thickest at that point; it, therefore, intussuscepts material more rapidly over a smaller area on its under surface at that region than elsewhere. Here constraint to growth is less in the third dimension than at other points in the blastoderm, and consequently it spreads slowest at the tail end of the embryo, or where it is thickest. This condition of inequality of thickness serves to explain the origin of conerescence.

Conerescence in a fish-egg, for example, is an effect of the unequal growth in thickness of the blastoderm, and is, consequently, to be regarded as an adaptive effect rather than as a cause.

Extending his view still further, the author sees in "heredity" itself only an effect, dominated and directed in its progressive complication by the laws of the conservation of energy. What the mechanism of heredity is remains to be discovered by an elaborate and connected study of the phenomena of organic growth, and the mechanisms and correlations of the same, and not by the assumption of the existence of unknowable as well as undiscoverable gemmules, plastidules, or germ-plasms.

Reproduction of *Noctiluca miliaris*.\*—Prof. C. Ishikawa has made a study of the division and spore-formation of *N. miliaris*. The division of the animal is preceded by the loss of the peristome, teeth, and tentacles, but the mouth and "Staborgan" are always present; the spore-forming individuals do not possess the two last-named parts. The division of the nucleus is always preceded by the concentration of part of the cytoplasm in the form of a spherical or oval granular body; this is the archoplasm or kinetic centre of division. In living animals at this stage the nucleus appears more or less homogeneous and transparent, but, treated with reagents, the chromosomes come into view distinctly. Each of these last consists of a row of disc-shaped microsomes irregularly scattered in the nucleoplasm; in the nucleus of a dividing animal each microsome-ring splits into half-rings, while in that of the spore-forming animal two successive divisions of a microsome-ring take place. The chromosomes collect on that side of the nucleus which is nearest to the archoplasm, and spread out towards the other pole; the archoplasm divides, and forms a very large spindle which first lies tangentially to the surface of the nucleus; this division is succeeded by the separation of the chromosomes into two groups, each attracted (?) by its respective archoplasm. The archoplasmic spindle pushes in the nuclear wall on which it lies, and the nucleus assumes in consequence the form of a half-ring. The fibres of the spindle are continuous from one pole to the other, and, as they lie outside the nuclear wall, they become in no way connected with the chromosomes. At this stage, however, another

\* Journ. Coll. Sci. Imp. Univ. Japan, vi. (1894) pp. 297-331 (4 pls.).

set of fibres is seen running from the centre of the archoplasm to the polar ends of the chromosomes. The structure of the spindle corresponds exactly with that of the spermatocyte of *Salamandra maculata*, as described by Hermann, save for the persistence of the nuclear wall in *Noctiluca*, and the consequent modifications. There are also "Verbindungsfäden" which originate from the linin-substance, while the central spindle-fibres arise from the archoplasm, and the radial fibres, probably, from both the cyto- and nucleo-plasms.

In the spore-buds the archoplasm lies close to the nucleus up to the time of the full development of the spore, just before its detachment from the mother animal, and part of it becomes transformed into the flagellum, in the same way as Strassburger has shown to happen for many vegetable swarm-spores. A centrosome, often of dumb-bell form, is generally seen in the centre of the archoplasm; sometimes there are two, and in many cases there are a number of small bodies which stain exactly like centrosomes, and may represent what Heidenhain has called the group of centrosomes. Neither the origin nor the fate of the centrosome is known; in a few cases it appears to be formed from the nucleus.

**Classification of Amœbæ.\***—Prof. A. Celli and Dr. R. Fiocca suggest several points as characters useful for a rational classification of Amœbæ. (1) Locality; beginning in the earth they pass into water, or into the intestine, but they have not been found in the air-passages, mouth or ear. (2) Form, movement, size, and structure are always very important, but do not suffice for exact definition. (3) Reproduction is always effected by division without previous conjugation, but the rapidity with which fission stages succeed one another differs in different species. (4) Though the characters of the resting stage are not of much importance they are not to be neglected. (5) On the other hand the marks of the cyst-stage are of great importance, and to a practised eye conclusive. (6) The differences in the length of the developmental cycle have a high diagnostic value.

The authors describe *Amœba lobosa* with its four varieties, *A. spinosa* sp. n., *A. diaphana* sp. n., *A. vermicularis*, *A. reticularis* sp. n., and *A. arborescens* sp. n.; a table is given in which the chief diagnostic characters can be easily seen.

**The Life of Amœbæ.†**—The same authors give a general account of the life of Amœbæ with particular reference to their pathological importance. They found that if the temperature was raised gradually the Amœbæ might survive 67°; and further experiments were made as to the influence of light, drought, &c. Amœbæ have a slight power of resisting acids, but a strong power of resisting alkaline reagents.

**Life-History of Foraminifera.‡**—An abstract is published of Mr. J. J. Lister's observations on the now well-known phenomenon of dimorphism in Foraminifera. Many species are found to be dimorphic, the differences lying in the size of the central chamber, the shape and mode of growth of the chambers succeeding the megalosphere and microsphere,

\* Centralbl. f. Bakteriol. u. Parasitenk., xvi. (1894) pp. 329-39.

† Riforma Medica, No. 68, 1894, p. 8, and No. 187, p. 20.

‡ Proc. Roy. Soc. Lond., lvi. (1894) pp. 155-60.



and in the character of the nuclei. It is found that in several species the microspheric form has many comparatively small nuclei, while the megalospheric form has a single large nucleus. The latter form is much more numerous than the former.

The megalospheric form has, in at least seven genera, been seen to arise as a young individual already invested by a shell, produced in the terminal or peripheral chambers of the parent. The parent may be megalospheric or microspheric. Foraminifera, in certain conditions, give rise to active swarm-cells.

The important question arises, are these two forms distinct from their origin, or is one a modification of the other. Mr. Lister adduces reasons in favour of the first explanation, and suggests that the two forms are members of a recurring cycle of generations.

From what has been seen in *Orbitolites complanata*, in which both micro- and megalospheric forms have been found with the young of the megalospheric form in their brood-chamber, it is necessary to suppose that, in some genera at any rate, the megalospheric form may be repeated for one or more generations, before the microspheric recurs. No evidence of such a repetition has been furnished by *Polystomella*.

The view that the life-history of the Foraminifera comprises more than one generation is in harmony with the fact that the nuclear history of the two forms in *Polystomella* appears to present resemblances to what have been described by Brandt in *Thalassicolla*; here the individuals fall into two sets, one of which produces isospores, and the other anisospores; and these are regarded as an asexual generation alternating with a sexual.

In the megalospheric form of *Polystomella* a simultaneous division of the nuclei by karyokinesis was observed immediately before the formation of the reproductive elements. This is a phenomenon of very general occurrence, and it is probable that it is akin to the division of the micronucleus which precedes conjugation in the Infusoria, and to the division of nuclei which occurs in the maturation of the reproductive elements in the higher forms of Animals and Plants.

*Saccamina*.\*—Dr. L. Rhumbler gives a most exhaustive account of *Saccamina spherica* M. Sars, which he obtained in abundance from the Baltic. The shell-wall is solid, with only one or two very minute apertures at the end of the papilla-like projections. Its cementing substance is horny, not chitinous, and the brown colour is due to impregnation with an iron salt. The youngest tests differed considerably from the older forms; what has been called *Psammosphæra fusca* F. E. Schulze is a second stage which is formed after the destruction of the primitive test; from this, by the formation of a pylome-tube, &c., the final form arises. Besides strayed Metazoa, six different unicellular organisms were found within the tests, one the true tenant, the others intruders. As to the structure of *Saccamina*, there is a definite peripheral layer, interrupted by the pseudopodia; special processes traversing the test have to do with building up the wall; the true pseudopodia have a webbed structure and small granules; the general substance of the cell is a spongy web, containing in its interstices particles taken in from

\* Zeitschr. f. wiss. Zool., lvii, (1894) pp. 433-536 (4 pls.), 587-617 (1 pl.).

outside, cementing particles, excretory granules, &c.; the nucleus shows nine phases, and is highly differentiated; linin and chromatin increase as nuclcoli (or "Binnenkörper") disappear; with changes in the nucleus is associated a cleansing of the cell substance from excreta and intrusions, a "defecation process" which may be very rapid; perhaps this process is antecedent to reproduction, which was not observed. Various particles—fecal, mineral, &c.—have been misinterpreted in connection with reproduction. Rhumbler names the five intruding organisms, *Rhynchogromia variabilis*, *Rhynchosaccus immigrans*, *Dactylosaccus vermiformis*, *Ophiotuba gelatinosa*, and *Dendrotuba nodulosa*. All are probably Protozoa, but the author does not commit himself to a classification.

Prof. W. Zopf\* describes the plasmodial state of a Myxomycete very like *Enteromyxa paludosa* Cienk., which spreads within the tests of *Saccamina*.

**Double Coccidian Infection.**†—M. A. Labbé adds three cases to the scanty list of the coexistence in one host of a monosporous and polysporous Coccidium. It will be remembered that this coexistence in the case of young Rabbits led Pfeiffer to his theory of the dimorphism of Sporozoa.

M. Labbé finds a great difference in size between a monosporous and a polysporous *Coccidium*, and he has had no difficulty in distinguishing their early stages; the thick membrane of the polysporous form is a simple cuticular membrane in the monosporous; the former are common, the latter rare and never present without the former. The fact of two parasites being present in the same organ of one host is not a proof of their derivation from one another, and if they are different in every stage of their life-history, we must conclude that they are different species.

**Amœba-Enteritis.**‡—Drs. Roos and Quincke isolated from two cases of chronic enteritis two species of *Amœbæ* which differed both morphologically and as to their pathogenic action on cats. In one case the parasites had apparently been obtained in Sicily, and these were smaller, more transparent, and moved more actively than those of the second case. They frequently contained a large number of red corpuscles, and rarely other foreign bodies in their interior; whilst the sluggish large Protozoa of the second case, which had in all likelihood been picked up in Schleswig-Holstein, never had blood, but bacteria or food-particles inside them. Even in the resting stage marked differences were observed, and a large number of inoculations on cats showed that the first *Amœba* was extremely virulent and the second harmless. The intestines were much ulcerated, and numerous abscesses were found not only in the intestinal walls but also in the liver. This organism is called *A. coli* Lösch s. *felis*; the harmless species *A. coli mitis*, the latter being probably identical with *A. intestini vulgaris*.

**Protozoa in Endometritis.**§—Dr. T. R. Doria found in three cases of endometritis bodies which he took to be *Amœbæ*. They were discovered in the canal, the glands, and in the epithelial cells of the cervical

\* Tom. cit., pp. 618-9 (2 figs.). † Comptes Rendus, cxix. (1894) pp. 537-9.

‡ Arch. f. Exp. Pathol. u. Pharmacol., xxxiii. (1894) No. 6 (2 pls.). See Centralbl. f. Bakteriologie u. Parasitenk., xvi. (1894) pp. 465-6.

§ Arch. f. Gynäkologie, xlvii. p. 1. See Centralbl. f. Bakteriologie u. Parasitenk., xvi. (1894) p. 465.

portion of the uterus. These bodies could not be mistaken for epithelial cells owing to their size, for they were five to eight times as large as a red corpuscle. Those within the cells were smaller than those lying free. In shape they were spheroidal to oval. The nucleus was smaller and less easily stainable than that of the epithelial cells, and a nucleolus was not constant. In fresh preparations, movements of the *Amœbæ* were observed.

**Trichomonas in Urine of Men.\***—Herr F. Marchand gives a very complete description of a case of a man in the urine of whom Trichomonads were found. The urine contained much albumen, and on standing a dirty yellowish purulent deposit was thrown down. In addition to epithelial and pus cells, &c., the Microscope showed the presence of peculiar hyaline bodies somewhat larger than leucocytes, and exhibiting movements. In size these varied from 0·012–0·03 mm. in length and 0·01–0·015 in breadth. The posterior end was rounded or terminated in a short straight tail-like prolongation. The anterior end was pointed or rounded, and the general shape of the animal was oval to round. Four flagella sprang from a common base at the anterior end. The protoplasm was homogeneous and hyaline, though sometimes it contained a number of small vacuoles. No contractile vesicle was observed. During life, when they exhibited amœboid movements and alterations of shape with pseudopodial extensions, no nucleus was visible; but on adding methylen-blue solution this was brought out as a round or oval body lying near the base of the flagella. In some nuclei nucleoli were present. Similar results were obtained with osmic and acetic acids and with sublimate.

The author then compares this organism with *Tr. vaginalis*, and shows that there is a close resemblance between the two.

Dr. K. Miura † has also observed a similar case, though in this instance there was no albumen in the urine or disease of the pelvic viscera as in the foregoing. The urine was yellow and acid, with some flocculent deposit, which on examination showed among other things mobile Infusoria somewhat larger than pus corpuscles. These organisms were somewhat pyriform in shape, the posterior end having a tail-like prolongation, near the base of which an expansion was occasionally present. At the anterior end were one, two, or three flagella. From the base of the flagella there extends down one side an undulating membrane which, from its constant movement, now appeared as if it were inside, now outside the body. The animals were very mobile and altered their shape continually. The average length of the body was 0·017 mm., breadth 0·012 mm.; of the flagella 0·01 mm., and of the tail 0·006 mm. The author concluded from experiments that these animals inhabited the urethra and not the bladder.

**Parasite of Vaccinia and Variola.‡**—Dr. M. A. Ruffer and Mr. H. G. Plimmer describe a parasitic protozoon which they have found in vaccinia pustules of man, cow, monkey, and rabbit. The parasite is a small round body, about four times the size of a staphylococcus. It usually lies in a vacuole in the cell plasma, and sometimes appears to have a more

\* Centralbl. f. Bakteriol. u. Parasitenk., xv. (1894) pp. 709–20 (1 pl.).

† Op. cit., xvi. (1894) pp. 67–73 (4 figs.).

‡ Brit. Med. Journ., June 30, 1894, pp. 1412–3.



darkly staining centre. It occasionally indents the nucleus. Multiplication appears to take place by simple division, and when examined fresh it shows amœboid movements. In the early condition of vaccinia these bodies occur in the Malpighian layer, but after a few days are only seen at the edge of the pustule. The same organisms were found in sections of skin and mucosa of variolous patients.

The tissue was fixed with saturated solution of sublimate, and afterwards hardened in alcohol. The sections were stained with hæmatoxylin, carmine, and lichtgrün, Ehrlich-Biondi, &c. The parasite was easily stained, but preferentially with protoplasmic dyes.

To the foregoing Dr. S. M. Copeman \* replies that the bodies described cannot be considered organisms special to vaccinia, since they can be "grown" in the corneal epithelium of the rabbit. The author (and Dr. Klein as well) has also shown that small bacilli are always present in the early stages of the vaccine vesicle of man and of the calf.

**Parasites of Sarcoma.**†—M. Gueynatz describes bodies which he has found in seven sarcomata. In position they are intranuclear, round or ovoid in shape, with a distinct outline but no definite membrane, and from 2-5  $\mu$  in diameter. These bodies have a decided affinity for red pigments, and contain slightly refracting granules varying in size from 0.5-1.5  $\mu$ . These bodies are most frequent at the growing edge of the tumour and are usually intranuclear, though occasionally they are seen in the cell-plasma or even free. As they persist during mitosis they are not nucleoli, nor do nucleoli contain bright refracting granules stainable with difficulty, nor are nucleoli found outside the nucleus.

The tumours were placed directly after removal in Flemming's fluid or pure spirit. The sections were stained with safranin and hæmatoxylin, or with some anilin dye and eosin.

Prof. Petroff ‡ has examined twenty-four sarcomata, and in all has found bodies very similar to those of carcinoma, although considerably smaller. They are usually located in the cell-plasma, and are rarely intranuclear or intercellular. In number, size, and arrangement they are extremely variable. Some are nucleated, in which case the nucleus stained green and the plasma yellow, while the nucleus of the tissue-cell stained blue. The cells containing these bodies are profoundly altered; they are hypertrophied, the nucleus being pushed aside and its chromatin forming an irregular mass. The number of these bodies varied with the kind of sarcoma, i. e. they were sparse in the spindle or round-cell sorts, but in the myeloid were frequent. The pieces were hardened in Müller's or Flemming's fluid. The best stains were found to be carbolyzed methylen-blue and anilin-yellow.

**Parasites of Cancer.**—According to Dr. P. Foà § the cancer-body consists of a nucleus surrounded by a thin layer of protoplasm and bounded by a doubly contoured capsule. This capsule is oftentimes finely and regularly striped, and the protoplasm so wrinkled that the whole body resembles a cockade or a rosette. These segments, however, cannot separate from another, and are not spores. The nucleus continues to

\* Op. cit., July 21, 1894, p. 157.

† Wratsch, 1894, Nos. 8 and 9. See Ann. de Microgr., vi. (1894) pp. 289-93.

‡ Gazette de Botkine, Jan. 1894. See Ann. de Microgr., vi. (1894) pp. 287-8.

§ Mittel. XI. Internat. Med. Kongr. in Rom. See Centralbl. f. Bakteriöl. u. Parasitenk., xv. (1894) pp. 816-7.



enlarge and the protoplasm gradually vanishes, after which the former divides up into so many small balls which represent spores. The cells inhabited by these corpuscles undergo a slow change which ends in necrosis. The spore enters (in some way) a young epithelial cell and there completes its development, i. e. until it becomes a cystic body containing spores.

Mr. J. J. Clarke \* in some observations on the histology of cancer, remarks of the Sporozoa which he had previously described, that these parasites are in some of their phases identical with those described by L. Pfeiffer, L. Wickham, Korotneff and Kurloff. Of epithelial pearls these bodies constitute the greater part. They are distinguished by their dense texture, their high refracting power, by their size and staining reactions. Their shape is most varied. That they are not devoid of vital activity is shown by the presence of mitotic figures with achromatic filaments. The author's illustrations, which are double stained (Ehrlich-Biondi), represent bodies, some with faintly laminated capsules and corpuscular contents stained red and green, some with thin doubly contoured capsules also containing corpuscular elements.

Dr. A. Ruffer,† who has always found that the cancer-body is invariably present in carcinoma, agrees with Foà as to its appearances, and with Duplay and Cazin that the Coccidia described by Wickham, Korotneff, Sawtschenko and others are cell-degenerations. For some time the author has studied, in conjunction with Plimmer, the appearances in fresh cancer juice. With oblique illumination the parasite can be seen quite well, and not unfrequently can be distinguished from the nucleus. Sometimes they thought they could detect movements. By treating the preparation with Loeffler's blue to which some drops of methylen-green have been added, a very characteristic reaction is obtained. The cancer-cell stains dark blue, the nucleus of the parasite is rose-coloured, and its plasma light blue.

Dr. Ribbert‡ criticizes the appearances described by the various observers who have written on the bodies, the Coccidia and the parasites of carcinoma and malignant neoplasms in general, and comes to the conclusion that none of the forms described as cancer parasites have anything typical about them, and that they can be satisfactorily explained as degenerations of the tissue-cell or its nucleus. He does not, however, go so far as to say that in the etiology of cancer parasites have no part.

*Tetramitus Nitschei*, a Parasite of Goldfish.§—Herr P. Nitsche and Dr. W. Weltner describe a new flagellate parasite on goldfish. It resembles in some respects *Bodo necator* Henneguy, an ecto-parasite of young trout, but is distinguished therefrom by its smaller size, by the possession of four flagella, by the absence of the longitudinal furrow which almost divides *B. necator* into two unequal halves, and by remaining on the adult fish. When adherent to the fish, *T. Nitschei* is pear-shaped, but when free swimming as observed in a drop of water under the Microscope it is oval. At the anterior end is a deepish depression.

\* Centralbl. f. Bakteriol. u. Parasitenk., xvi. (1894) pp. 281-5 (1 pl.).

† Mitteil. XI. Internat. Med. Kongr. in Rom. See Centralbl. f. Bakteriol. u. Parasitenk., xvi. (1894) pp. 460-1.

‡ Deutsche Med. Wochenschr., 1894, No. 15. See Centralbl. f. Bakteriol. u. Parasitenk., xv. (1894) pp. 962-5.

§ Centralbl. f. Bakteriol. u. Parasitenk., xvi. (1894) pp. 25-30 (4 figs.).

The nucleus lies about the middle of the animal and the contractile vesicle posteriorly. It measures about 0·0136 mm. long and about 0·0051 mm. broad. There are four flagella, two long and two short.

**Structure of the Malaria Parasites of the Summer and Autumn Fevers.\***—Drs. Bastianelli and Bignami made preparations of the blood and spleen juice of malarious persons, and treated the material by spreading it on cover-glasses, drying at room temperature, fixing with equal parts of absolute alcohol and ether, and then staining with hæmatoxylin and eosin. The young *Amæba* consists of cytoplasm, of which the external layer only stains. In all are visible one or more chromatin granules, but a nuclear body could not be clearly determined. As soon as they begin to multiply, the chromatin granules disappear. The cytoplasm increases in amount and becomes granular or homogeneous, while at the same time pigment collects in the centre or at the side of the parasite. In this way the "small bodies" with central pigment about one-fourth or one-fifth the bulk of a red corpuscle arise. These are composed of a homogeneous plasma the outer layer of which is thicker than the central portions. At this stage proliferation suddenly occurs, though it not unfrequently happens that the small body with central pigment continues to grow, though apparently never attaining the size of a red corpuscle. In the largest forms found free in the plasma and in the spleen, degeneration appearances are to be observed. The stage of multiplication is marked by the appearance of minute coloured puncta in the body of the parasite. These gradually coalesce, and finally a definite collection of chromophilous protoplasm is formed. Spores produced in this way differ from young plasmodia in that they have a definite and constant form, are devoid of achromatic cytoplasm and are motionless. The authors maintain that in this variety of parasite a true nucleus cannot be demonstrated. The chromatin granules which form a part of the cytoplasm, and which are dissolved in this in the preliminary stage of proliferation, represent the first and most important stage of the young spores and are to be regarded as that part of the parasite which performs the function of a nucleus. From the rapid and constant proliferation it may be inferred there is no resting stage of the nucleus. The crescent-shaped forms are usually faintly, though regularly stained. Frequently they are without chromatin granules. They have no membrane, and there is no differentiation of the protoplasm. The authors are of opinion that these forms are to be regarded as a sterile phase in the life-history of the parasite.

**Protozoa in Abscess of Lung and Liver.†**—Herr Grimm found in the sputum, and in the pus of pulmonary and hepatic abscesses, Flagellata of fairly high organization. These bodies were from 30 to 60  $\mu$  long, of the shape of a myrtle leaf, and have a long tail-like process. The somatic parenchyma was enclosed by a definite and highly refracting margin which by internal prolongations divided the body into three compartments. The author inclined to the view that the two abscesses had different sources of infection.

\* Mitteil. XI. Internat. Med. Congr. in Rom. See *Centralbl. f. Bakteriol. u. Parasitenk.*, xvi. (1894) pp. 357-8.

† *Langenbeck's Arch. f. Chirurgie*, xlviii, No. 2. See *Centralbl. f. Bakteriol. u. Parasitenk.*, xvi. (1894) p. 534.

## BOTANY.

A. GENERAL, including the Anatomy and Physiology  
of the Phanerogamia.

## a. Anatomy.

## (1) Cell-structure and Protoplasm.

**Eye-spot.\***—Dr. A. Zimmermann gives a review of what is known respecting the red eye-spot or “stigma” in the lower forms of animal and vegetable life. According to Franzé and other observers, the presence or absence of this structure is not uniform even in the same species. As a rule the eye-spots are confined to organisms containing chlorophyll; their number is occasionally more than one, but not often. Their function is probably connected with the receptivity of the organism for light, but even this is not certain.

**Cilia and Pseudo-cilia.†**—Dr. A. Zimmermann describes the structure of the cilia in the lower forms of animal and vegetable life, according to the observations of the most recent authorities. In cells enclosed in a cell-wall their connection with the protoplasmic contents can be traced. The structures termed “pseudo-cilia” by Correns‡ are not endowed with motility, and are more of the nature of hairs than of true cilia.

**Structure of the Nucleus in Mucorini.§**—MM. P. A. Dangeard and M. Léger give further details of the structure of the nucleus in various Mucorini. It has a nuclear membrane separated from a central nucleole by cytoplasm containing but little chromatin; the nucleole is very dense and strongly stainable. In the gametes (*Sporodinia grandis*) the nuclei are very numerous, and are imbedded in a reticulate protoplasm. The number in each gamete varies from three to seven in *Mucor*, from twenty to fifty in *Sporodinia*. They are derived from the thallus without division in the sporange. After the contents of the two gametes have united to form the zygospore, the very numerous nuclei are imbedded in an exceedingly finely reticulate protoplasm, and are of two kinds, the one two or three times as large as the other. At a later period this difference disappears, the nucleole is reduced to a simple central dot, and the nucleus to a small vacuole. In the mature zygospore is a large central vacuole, or sometimes two eccentric ones, the origin of which is obscure.

## (2) Other Cell-contents (including Secretions).

**Absorption-spectrum of Chlorophyll.||**—M. N. Monteverde states that the absorption-spectrum of living leaves consists of seven bands and a terminal absorption; the order of intensity of the former is as

\* Bot. Centralbl., 1894, Beih., pp. 161-5.

† Tom. cit., pp. 169-71.

‡ Cf. this Journal, 1893, p. 663.

§ Le Botaniste (Dangeard), iv. (1894) pp. 4-11 (7 figs). Cf. this Journal, ante, p. 486.

|| Acta Hort. Petropol., 1893, pp. 123-78 (1 pl.). See Bot. Centralbl., lix. (1894) p. 239.

follows:—Ia, VI, V, Ib, II, III, IV. The spectrum of the alcoholic extract differs only in the absence of Ib, and in a slight shifting of all the bands. These results differ from those of most other authors, in consequence of the mode of treatment. Instead of first boiling in water, the author extracts the chlorophyll at once with cold 95 per cent. or absolute alcohol. The alcoholic extract always contains two green and two yellow pigments. The two latter are separated by precipitating by baryta, and extracting the precipitate by alcohol. If this extract is then agitated with petroleum-ether, the carotin is dissolved in the ether, the xanthophyll in the alcohol. They are easily distinguished from one another by various reactions.

The two green pigments are termed by the author amorphous and crystalline chlorophyll. Their relative amount differs greatly in different leaves. Amorphous chlorophyll is characterized by the complete absence of band V from its spectrum. It is more soluble in benzin, petroleum-ether, and carbon bisulphide, than in alcohol. Crystalline chlorophyll may be obtained from certain leaves (e. g. *Dianthus barbatus*, *Dahlia variabilis*) simply by evaporating the alcoholic extract; and purifying the crystals by water and benzin. They are completely insoluble in petroleum-ether, carbon bisulphide, and ordinary benzin; soluble in alcohol, ether, chloroform, and pure benzin. It is probable that living leaves contain this kind only of chlorophyll.

The alcoholic extract of *Oscillatoria*-filaments contains carotin, phycocanthin, and both kinds of chlorophyll. Phycocyan is not soluble in alcohol.

The same author\* finds, in etiolated leaves, besides xanthophyll and carotin, a pigment to which he gives the name *protochlorophyll*. It displays a distinct red fluorescence, and exhibits a line in its absorption-spectrum corresponding to band III of chlorophyll, and a second characteristic band at some distance from band II of chlorophyll. Band I is entirely wanting. The spectrum attributed by Pringsheim and Tschirch to etiolin is probably a combination of the spectra of a modified chlorophyll, of protochlorophyll, of carotin, and of xanthophyll.

**Chemistry of Chlorophyll.**†—In his latest contribution to this subject Dr. E. Schunck gives the result of investigations on various products derived from chlorophyll, especially on the preparation of pure phyllotaonin.

**Occurrence of several Chlorophylls in the same Plant.**‡—In the leaves of the lucerne M. A. Etard finds no fewer than four distinct chlorophylls. To one of these, especially characteristic of the plant, an amorphous chlorophyll, he gives the name *medicagophyll*.

**Formation and Localization of Fatty and Essential Oils.**§—According to the researches on this subject of M. E. Mesnard, fatty oils are not, except in the case of grasses, localized in special layers of cells. They are found in all the cells of a particular region, such as the endosperm, pulp of fruit, leaf, rhizome, &c. In seeds the albuminous

\* Op. cit., xiii. (1894) pp. 201-17. See Bot. Centralbl., lix. (1894) p. 284.

† Proc. Roy. Soc., lv. (1894) pp. 351-6. Cf. this Journal, 1893, p. 59.

‡ Comptes Rendus. cxix. (1894) pp. 289-91.

§ Ann. Sci. Nat. (Bot.), xviii. (1894) pp. 257-397 (3 pls.).



reserve-substances have a similar distribution, and there appears to be an intimate relationship between the two classes of substances. They have, however, an entirely independent origin; in fruits, leaves, stems, &c., the fatty oils are not accompanied by albuminoids. The former are produced within the green protoplasm. The disappearance of the reserve oily substances is not the work of any special diastase (saponase). In the seeds of grasses, on the other hand, which may be regarded as oily seeds with an external reserve of starch, the starchy substances are assimilated by a diastase (amylase) elaborated in a special epiderm.

The essential oils of plants were studied in a great number of species belonging to many natural orders. In the flower, they are usually found localized in the epidermal cells of the upper or under surface of the petals or sepals; in the leaf, in the epidermal cells of the upper surface; in the stem and fruit, in the epiderm. They appear always to originate in the chlorophyllaceous protoplasm, passing through the intermediate stage of tannoid substances. In its decomposition the chlorophyll gives rise also to other substances, such as tannins, latex, pigments, &c. Hence white petals, in which the transformation into essential oils has been the most complete, are often the most strongly scented; while brown and orange petals, in which pigments have been produced in large quantities, are more frequently scentless.

**Localization of Alkaloids.\***—M. G. Chautriau distinguishes five types in the mode of distribution of alkaloids in plants, viz.:—(1) In a layer of cells lying between the endosperm and the true testa (*Atropa Belladonna*, *Datura Stramonium*, *Hyoscyamus niger*); (2) in two layers (especially in the outer one) between the endosperm and the pericarp; also, to a smaller extent, in the epiderm and in the cells which accompany the vascular bundles (*Conium maculatum*); (3) in the endosperm, especially in its peripheral cells (*Aconitum Napellus*, *Delphinium Staphisagria*); (4) in all the cells of the endosperm, and to a smaller extent in those of the embryo (*Strychnos Nux-vomica*); (5) apparently in the cotyledons and plumule (*Lupinus albus*).

The alkaloids take no active part in germination, but are formed in the seedling from decomposition of the albuminoids.

In *Papaver somniferum* the amount of alkaloids decreases as the seeds ripen, and this is accompanied by an elimination of nitrogen. As in the other plants examined, they are not used by the plants as nutritive substances; their main function is protection against animals.

**Formation and Function of Tannins.†**—Herr G. Mielke disputes the statement that tannic acids are ever produced out of albuminoids. The previous stages of their formation are phenols, phenol-alcohols, aldehydes; these occur, in chemical combination with sugar, as glucosides, and play an important part in vegetable economy, since they are the indispensable materials for the production of lignifying substances. True tannins are stored up only in small quantities in vegetable tissues; they can take part in metastasis only when they revert to their previous stages by absorption of water. Resins and essential oils are probably the final results of the metamorphosis of tannins.

\* Bull. Soc. Belge Micr., xviii. (1894) pp. 33-54.

† Progr. d. Realsch. v. d. Holstenthore in Hamburg, 1893, 38 pp. See Bot. Centralbl., lix. (1894) p. 280.

**Elaioplasts and Elaiospheres.\***—The literature of elaioplasts is reviewed by Dr. A. Zimmermann, both with reference to flowering plants and to Hepaticæ. The somewhat similar bodies found by Radlkofer and others† in the spongy and palisade parenchyme of plants belonging to several natural orders, are distinguished by Lidforss under the name *elaiospheres*.‡ They usually give the reaction of oil.

**Spherocrystals of Agave.§**—In the bracts, flowers, and fruits of *Agave mexicana* and *cærulescens* preserved in alcohol, Sig. L. Re finds reddish or yellowish bodies which exhibit all the ordinary reactions of spherocrystals.

**Proteolytic Ferments in Seedlings.||**—Herr R. Neumeister has employed the property of fibrin of absorbing ferments from their solutions to determine their presence in growing seedlings. Fresh fibrin was soaked in aqueous extracts of the seedlings, and the fibrin then removed and placed in acid and alkaline mixtures. By this process it was demonstrated that a number of seedlings (barley, poppy, maize, wheat, rape) contain a ferment which dissolves proteids. It is not present at the earliest stages, but increases with the growth of the plant. Like pepsin, it works only in acid liquids, a vegetable acid like oxalic being necessary. It appears to produce peptone out of the proteids, which assists in the nutrition of the seedling. In other seedlings (lupin, vetch, pea, rye, oat) the ferment was not found.

**Calcium Oxalate in Solution.¶**—M. E. Belzung points out that calcium oxalate may occur in plants, not only in the crystallized form, but also in solution in the cell-sap. It is then dissolved in one of the organic acids, and probably in a state of unstable combination with it, as calcium citroxalate or oxoxalate, according as the dissolving acid is citric or oxalic. In this condition it may play the part of a reserve-nutritive-substance for the plant. The cell-protoplasm is protected from the poisonous influence of free oxalic acid or an oxalic salt in the cell-sap by the tonoplast of the vacuole.

### (3) Structure of Tissues.

**Wood and Pith at the bounds of the Annual Growth.\*\***—Herr E. Jahn has made a series of observations on a great variety of woody plants, for the purpose of determining the nature of the tissue on the confines of two annual rings of growth. He finds that, in the woody portion, the width of the ring diminishes rapidly as soon as it reaches the region of the bud-scales. The cells become shorter and narrower, and in Dicotyledons there are only parenchymatous cells and tracheids. The predominant forms of thickening are reticulate and spiral. There is an evident tendency to facilitate a connection, in the radial direction, with the next annual ring. In the pith the radial arrangement of the cells is no longer apparent. In the region of the bud-scales is the intermediate pith, a tissue of closely packed cells possessing pores, and filled

\* Bot. Centralbl., 1894, Beih., pp. 165-9. † Cf. this Journal, *ante*, p. 467.

‡ See Acta Univ. Lund., xxix. (1892, 93).

§ Ann. R. Ist. Bot. Roma, v. pp. 38-40. See Bot. Centralbl., lix. (1894) p. 339.

|| Zeit. Biol., xxx. pp. 447-63. See Journ. Chem. Soc., 1894, Abstr., p. 290.

¶ Journ. de Bot. (Morot), viii. (1894) pp. 213-9.

\*\* Bot. Centralbl., lix. (1894) pp. 257-67, 321-9, 353-61 (1 pl.).

with starch in winter. Great abnormalities are presented by some genera of conifers.

**Fruit-bearing Axis of Palms.\***—M. H. Micheels has studied the structure of the axis which bears the fructification in 32 species and varieties belonging to 19 genera of palms. The following are the more important results. Every vascular bundle is completely enclosed in a sclerenchymatous sheath. The xylem usually contains a few vessels of remarkably large size. In some species the bundles are free, and imbedded in a homogeneous or irregular fundamental tissue. In other species the inner bundles are the largest, and are united by their sclerenchyma-sheath into a more or less uninterrupted ring. In others again, all the bundles unite, by the coalescence of their phloem portion, into a central string with larger or smaller interstices.

**Anatomy of the Stem of Thunbergia.†**—While many species of this genus exhibit a normal structure of the stem, others present abnormalities in various directions. These are described by M. C. Roulet, especially the anatomical peculiarities of the section *Hexacentris*. Two parallel elongated leptome-islands occur here in the xylem, in vertical lines corresponding to furrows in the stem. The alternating zones of leptome and hadrome are caused by the cambium giving off alternately xylem and phloem on its inner side.

#### (4) Structure of Organs.

**Bright Colour of Alpine Flowers.‡**—Dr. J. Joly adduces numerous instances in which the flowers of Alpine plants are more brightly coloured than those of the same species growing at lower altitudes. He attributes this primarily to the scarcity of pollinating insects at high altitudes, only those individual plants surviving, in the struggle for existence, which are especially endowed, from the size or brightness of their flower, with the power of attracting insects. Large numbers of insects appear to perish from cold on the higher Alps, being attracted in the dusk by the light from the snow.

**Extra-floral Nectaries of *Aleurites*.§**—Mr. P. Groom has examined the structure of the nectaries which are found on the petiole of special unlobed leaves of *Aleurites cordata* belonging to the Euphorbiacæ, with relation to the question whether the laticiferous tubes contain carbohydrates or not. He finds only a very slight connection between these tubes and the secreting cells of the nectary.

**Self-adaptation of Plants to their Environment.||**—Rev. G. Henslow gives a variety of exemplifications of the special characters of desert plants, drawn from the flora of Egypt, arranged under the following heads:—General Morphological Characters; Spinescent Characters; Foliage; Succulent Plants; Protection of Buds; Roots; Histological Peculiarities; Assimilating Tissues; Ligneous Tissues; Water-storage

\* Mém. Acad. R. Sci. Belgique, liii., 52 pp. and 1 pl. See Bot. Centralbl., lix. (1894) p. 186.

† Bull. Herb. Boissier, i. (1894) p. 259 (1 fig.). See Bot. Centralbl., lix. (1894) p. 369.

‡ Scient. Proc. R. Dublin Soc., viii. (1893) pp. 145-53 (1 fig.).

§ Ann. Bot., viii. (1894) pp. 228-30.

|| Journ. Linn. Soc. (Bot.), xxx. (1894) pp. 218-63 (1 pl.).



Tissues; Secretions. The general conclusions which he draws, from innumerable coincidences between structure and environment, are that there is some common relationship between them of cause and effect, and that all parts of plants are subject to variation. While these variations, on the one hand, may be merely casual, accidental, and transient, they may, on the other hand, become more and more persistent and characteristic, and hence hereditary. He regards this cumulative evidence as amounting practically to a demonstration that varietal and specific characters are acquired solely through the direct action of the environment. The author concludes with some observations on the origin of the very general inconspicuousness and self-pollination of desert flowers.

**Adaptation of Fruits to Climate.\***—Dr. J. R. Jungner points out the adaptation in the form of many fruits to the climate, especially to the very heavy rainfall of the Cameroon region. This is frequently exhibited in a similar contrivance to that which occurs in the case of many leaves, a pendent habit, and an elongated apex which facilitates the running off of the water. Fleishy fruits are especially characteristic of hot climates, and—in addition to their adaptation for transport by animals—serve to store up moisture to counteract excessive insolation. Nut-like and other woody fruits are, on the other hand, more abundant in cold climates, where the rainfall is small during the period of vegetation.

**Rumination of the Seeds of *Areca Catechu*.†**—According to Herr Osenbrug, the rumination in the seeds of this palm makes its appearance either immediately before or immediately after fertilization. It commences from the funicle in the form of cushions, above the spots where the vascular bundles enter, projecting into the embryo-sac, accompanied by branches of the bundles. The rumination, therefore, resembles that of the nutmeg in having nothing to do with the integuments. The structure which has been called rumination in some seeds, such as those of the ivy and of *Rhamnus catharticus*, is not properly so termed; but is rather an example of seeds with folded or lobed endosperm. The projections which constitute the rumination, and not the interior of the endosperm, are the seat of the alkaloids and tannins in the *Areca*-seed.

**Mechanical Theory of Phyllotaxis.‡**—Herr A. Weisse discusses the two theories with regard to the origin and persistence of the different modes of phyllotaxis:—that they are due to the influence of external conditions, and that they have become fixed in each species by heredity. From a series of observations made on the adventitious buds of a number of woody plants, he decides in favour of the former explanation. Especial stress is laid on the fact that, in adventitious buds, the position of the first leaves is entirely dependent on mechanical factors.

**Double Leaves of the Honeysuckle.§**—Herr L. J. Celakovsky discusses the cause of the occasional occurrence of four leaves in a whorl in *Lonicera Periclymenum*. It is the result of the co-operation of two

\* Bot. Centralbl., lix. (1894) pp. 65-74 (2 pls.). Cf. this Journal, 1892, p. 62.

† 'Ueb. d. Entwicklung d. Samen d. *Areca Catechu* u. d. Bedeutung d. Ruminationen,' Marburg, 1894. See Bot. Centralbl. lix. (1894) p. 190.

‡ Jahrb. f. wiss. Bot. (Pringsheim), xxvi. (1894) pp. 236-94 (2 pls.).

§ Tom. cit., pp. 1-48 (3 pls.).



opposing tendencies, one tending to the increase, the other to the decrease of the number of leaves in a whorl.

**Root-tubercles of Leguminosæ.\***—Mr. H. L. Bolley enumerates 21 species of Papilionaceæ, natives of northern Dacotah, growing in a great variety of situations, which produce tubercles on their roots. Though he has not positively determined the point, the author inclines to the opinion that each host has its specific tubercle-producer.

**Root-tubercles of Arachis.†**—M. H. Lecomte describes the structure of the root-tubercles of *Arachis hypogea*, which agrees closely with that of those found on the stem of *Trifolium repens*. The central parenchyme contains protoplasmic bacteroids and mycelial filaments passing from cell to cell. The formation of the tubercles is accompanied by a very large deposit of nitrogen in the seeds in the form of aleurone. M. Lecomte points out the very great importance in agriculture of this property of *Arachis* of accumulating nitrogen out of the atmosphere.

**Root-hairs.‡**—According to Mr. T. Jamieson, in many plants the root-hairs are not composed of closed cells, but are furnished with a small aperture a little below the apex, through which even solid particles can be taken up by the hair out of the soil. The aperture was observed in the following plants: the turnip, pea, carrot, lupin, tobacco, barley, and potato.

### B. Physiology.

#### (1) Reproduction and Embryology.

**Embryology of the Amentiferæ.**—Miss M. Benson § has investigated the embryology of various species belonging to the Cupuliferæ, Corylaceæ, and Betulaceæ. They agree in the hypodermal character of the archesporium, and in the presence of tapetal cells; the archesporial cells are arranged in strands, forming a sporogenous tissue. In all of them the pollen-tube sometimes branches, and forms recurved cæca before entering the nucellus. There is also a prevalent formation of cæca by the embryo-sac.

The Cupuliferæ (*Fagus*, *Castanea*, *Quercus*) show but little departure from the ordinary type of Angiosperms; but in *Castanea* there is a remarkable formation of tracheids at the base of the embryo-sac.

The Betulaceæ (*Betula*, *Alnus*) agree with the Casuarinæ in their chalazogamic character, i. e. the pollen-tube does not enter the micropyle, but penetrates the nucellus from the chalazal region; and this is also the case with the Corylaceæ (*Corylus*, *Carpinus*). In the two latter genera there are a large number of megaspores, which continue their development up to the stage of forming two or four nuclei.

In all the Amentiferæ the pollen-tube goes through a resting period varying from one month in *Betula* to eleven months in some species of *Quercus*, no trace of the ovule being present, in the latter case, at the time of pollination. In the chalazogamic orders Corylaceæ and Betulaceæ, the course of the pollen-tube very closely follows that described

\* Agric. Sci., vii. (1893) pp. 58–66. See Bot. Centralbl., 1894, Beih. p. 294.

† Comptes Rendus, cxix. (1894) pp. 302–4. Cf. this Journal, ante, p. 83.

‡ Science (New York), xxii. (1893) pp. 354–6 (44 figs.). See Bot. Centralbl., 1894, Beih., p. 229. § Trans. Linn. Soc. (Bot.), iii. (1894) pp. 409–24 (6 pls.).

by Treub in the Casuarineæ. It descends from the tissue at the base of the styler rudiments, and, running parallel with the vascular bundle of the rapha, turns abruptly up into the nucellus on reaching its chalazal region. Various adaptations to chalazogamy also occur in the structure of the embryo-sac.

Herr S. Nawaschin's\* observations agree to a large extent with those of Miss Benson, and confirm his previous statement as to the chalazogamic character of the Betulaceæ. He further adds *Ulmus* to the list of chalazogamic plants, this genus presenting an intermediate condition between the Casuarineæ and the Amentifereæ. The pollen-tube does not here reach the nucellus through the micropyle, but forces itself through the tissue of the short style, then passes through the funicle to the ovule, reaching the apex of the nucellus by piercing both integuments.

**Embryology of Ephedra.**†—M. P. Jaccard has carefully studied the development of the embryo of *Ephedra helvetica* (Gnetaceæ). The following are the most important results:—

The female flower is composed of a sessile ovule at the apex of a secondary branch. It has a single integument, and is surrounded by a shell (*coque*), which is composed of bracts, and is not, therefore, morphologically an ovary. The embryo-sac results from the enlargement of the lowest of the 3-4 cells due to the division of a primordial mother-cell. Its development comprises four periods,—the nuclear period, that of the formation of the primary endosperm, of the corpuscles, and of the secondary endosperm. The free nuclei of the embryo-sac all divide simultaneously, and present the same karyokinetic figure. The number of chromatic segments of the nucleus is less in the endosperm than in the other tissues. The archegones are developed from primary endosperm-cells similar to the rest. Before impregnation the epiderm of the nucellus is transformed, in its free portion, into a layer of transitory reserve-substances, but its large cells persist until the formation of the integument of the seed.

The pollen-grain contains, when mature, three nuclei, a large central nucleus surrounded by protoplasm (Belajeff and Strasburger's antheridial cell), and two vegetative polar nuclei, one of which is the nucleus of the pollen-tube, while the other may be regarded as the homologue of the prothallium-cells of Conifers, or as a detached nucleus of the antheridial cell. The nucleus of the antheridial cell divides into two generative nuclei, one only of which takes an active part in impregnation.

After impregnation the archegone is filled with a mass of condensed protoplasm and of nuclei resulting from the disorganization of the corpuscular envelope. The archegone then becomes disorganized; and in its place is formed a lignified tissue to which the author applies the term *columel*. The columel retreats towards the middle of the endosperm, and bears at its apex the privileged embryo, the only one which develops. It plays, therefore, the part of a primary suspensor; the remaining abortive embryos have no pro-suspensor. The secondary suspensor is well developed, and is the result of transformation of the

\* Per. Deutsch. Bot. Gesell., xii. (1894) pp. 163-9 (6 figs.). Cf. this Journal, 1893, p. 656.

† Bull. Soc. Vaud., xxx. (1894) pp. 46-84 (8 pls.).

oldest cells of the embryo. As the cells of the suspensor, attached to the apex of the columel, elongate, it forces the embryo towards the chalazal end of the embryo-sac. In its growth, the embryo does not gradually consume the whole of the endosperm, but only a special zone of it which is filled with food-materials. The final envelope of the seed is formed of a membranous pellicle proceeding both from the integument and from the nucellus, and of the "shell" which persists until the period of germination.

**Occasional Cleistogamy.\***—Herr P. Graebner has observed the occasional occurrence of cleistogamous flowers, which nevertheless produced perfect seeds, in the following plants:—*Gentiana Pneumonanthe*, *Gesnera bulbosa*, *Coleus aromaticus*, *Orobanche minor*. The production of these flowers appeared to be the result of unfavourable climatal conditions.

**Cross- and Self-Pollination.**—According to Sigg. G. Gibelli and L. Buscalioni,† the flowers of *Trapa natans* and *T. Verbanensis* are self-pollinated and cleistogamous. While still under water, the flowers remain closed, but open when exposed to the air, in consequence of the carpotropic curvature of the flower-stalk; and by this time pollination has taken place. It is accompanied by an abundant excretion of nectar.

Herr P. Knuth‡ has investigated the conditions of pollination in about 400 species of flowering plants growing in the islands of N. Friesland. He states that among these, 4 species are hydrophilous, 145 anemophilous, 12 self-pollinated, and 239 entomophilous; in 167 of these self-pollination is possible. The proportion of anemophilous species is much larger than in Continental Germany. A detailed account is given of the visiting insects, and some remarks are appended respecting the structural peculiarities of the plants which inhabit these islands.

Herr F. Heim§ states that the flowers of *Vincetoxicum officinale* and *Apocynum venetum* are visited both by diptera which assist in the pollination, and by injurious small flies. From the latter they are, however, to a certain extent protected by spiders.

Mr. E. Walker|| describes the mode in which the pollen is expelled from a terminal pore in the anther of *Richardia africana*. The plant is proterogynous, and apparently dependent on insect-pollination.

Experiments made by Miss M. Reed¶ on cultivated varieties of *Petunia* appear to demonstrate the advantage of cross- over self-fertilization.

Herr O. Ekstam\*\* gives some interesting facts regarding the pollination of flowers in Nova Zembla. That country possesses three species of *Pedicularis*, which are self-pollinated, although there are several species of *Bombus* which are the pollinating agents of the genus in other arctic countries. In Nova Zembla they appear never to visit its flowers; and

\* Verhandl. Bot. Ver. Prov. Brandenburg, 1894, pp. 148-54.

† Rend. Accad. Lincei, ii. (1893) pp. 227-36. See Bot. Centralbl., 1894, Beih., p. 223.

‡ 'Blumen u. Insecten d. nord-friesischen Inseln,' Kiel, 1894, 207 pp. and 23 figs. See Bot. Centralbl. 1894, Beih., p. 225.

§ Bull. mens. Soc. Linn. Paris, 1893, p. 1096. See Bot. Centralbl., lix. (1894) p. 245. || Bot. Gazette, xix. (1894) pp. 241-3.

¶ Tom. cit., pp. 336-7.

\*\* Ofv. K. Vetensk. Akad. Förh. Stockholm, li. (1894) pp. 79-84 (German).

the author explains this on the hypothesis that *Pedicularis* reached that country and became adapted to self-pollination before the arrival of the insect. *Saxifraga oppositifolia* is abundantly visited by the bees, and *Matthiola nudicaulis* to a smaller extent. *Polemonium pulchellum* is not visited by them.

In *Impatiens fulva* Mr. T. Meehan\* states that the perfect flowers are, equally with the cleistogamous ones, self-fertile, insects taking no part in the pollination. Nectar is present in the spurs both of the cleistogamous and of the perfect flowers.

Pollination of the Hop.†—In a detailed account of the anatomy of the hop-plant, Dr. J. Behrens describes the geotropic and heliotropic curvatures of the female inflorescence, by which it becomes specially adapted for anemophilous pollination.

Pollination of the Pear.‡—The results of a large series of experiments made by Mr. M. B. Waite on a great number of varieties of the pear in the United States are decidedly favourable to crossing. He states that many of the common varieties are partially or wholly incapable of setting fruit when limited to their own pollen, while some other varieties are capable of self-fertilization. Pollen from another tree of the same variety acts no better than pollen from the same tree. The state of nutrition of the tree and its general environment affect its ability to set fruit, either with its own pollen or with that of another tree. If self-fecundated pears contain seeds, they are usually abortive. Even with those varieties which are capable of self-fecundation, the pollen of another variety is pre-potent.

(2) Nutrition and Growth (including Germination, and Movements of Fluids).

Transpiration and Assimilation.—Prof. E. Stahl§ has undertaken a series of experiments to determine the connection between these processes in living plants. He distinguishes between stomatal and cuticular respiration, the latter being comparatively insignificant with land plants so long as they have a sufficient supply of water. In many plants it is certain that the stomates give off water directly into the air, and not through the adjacent epidermal cells. Since the stomates open most widely when the air is saturated with moisture, and when they are at the same time exposed to the action of the sun, a large amount of water in the air may promote transpiration. In many plants which grow in moist situations, the stomates do not close. But, as a general rule, when a leaf withers, the stomates close, and the leaf loses its power of forming starch. Assimilation takes place most rapidly when there is direct sunshine, and when the air is at the same time moist, i. e. when the stomates are fully open. The essential part played by the stomates in assimilation can be proved by artificially closing them by some gummy substance which does not injure the plant, when the process of assimilation is almost entirely suspended.

\* Proc. Acad. Nat. Sci. Philadelphia, 1894, pp. 54-7.

† Flora, lxxviii. (1894) pp. 361-98.

‡ U.S. Deptmt. of Agriculture; Div. of Veg. Pathology, Bull. No. 5, 86 pp., 12 pls. and 4 figs., 1894. § Bot. Ztg., lii. (1894) 1<sup>te</sup> Abtheil., pp. 117-45 (1 pl.).



Herr R. Meissner\* corroborates Stahl's results in the main. He finds that when dorsiventral leaves are inverted their power of assimilation is reduced; while the assimilation of isolateral leaves is only slightly affected by inversion.

**Nutrition of Green Parasites.**† — M. G. Bonnier points out that parasitic flowering plants which contain chlorophyll present all intermediate stages between those which derive their carbon almost entirely from their host, and those which obtain it mainly from their own power of assimilation. Thus *Euphrasia officinalis* gives out no oxygen, even in a bright light, and *Bartsia alpina* and *Rhinanthus crista-galli* only a very small quantity; while *Thesium humifusum*, *T. pratense*, and *Pedicularis sylvatica*, although they have well-developed haustoria, exhibit a notable degree of assimilation, which is still more pronounced in *Melampyrum pratense*, *sylvaticum*, and *nemorosum*. The former, therefore, notwithstanding their green leaves, are true parasites; while the latter, notwithstanding their well-developed haustoria, display but a feeble parasitism.

**Influence of Mechanical Resistance on the Development of Cells.**‡ — After reviewing the conclusions of Pfeffer and others,§ Mr. F. C. Newcombe describes experiments of his own on this subject, from which he derives the following results:—The meristematic tissue of growing points, intercalary zones, and cambium will preserve its functional capability for a considerable period when growth is prevented by an external mechanical resistance. Under such circumstances the tissue remains apparently unaltered, the cells do not divide, and neither the thickness nor the composition of the cell-wall undergoes any change. External resistance delays all the processes of development, such as the differentiation of tissues, lignification of the elements of the vascular bundles, formation of cork, &c. Cells which reach their permanent development in these conditions have a smaller size and thinner walls than is normally the case. The power of cambium to form new cells under external pressure is greater than that of tissues derived from the cambium.

**Exchange of Carbon Dioxide and Oxygen.**|| — In a fresh series of experiments on a variety of flowering plants, M. T. Schlœsing finds the proportion  $\frac{\text{CO}_2}{\text{O}_2}$  to be very nearly identical, viz. 0.848–0.90. With Algæ (*Protococcus vulgaris*, *Chlorococcum infusionum*, *Ulothrix subtilis*, *Scenedesmus quadricauda*), the proportion was somewhat smaller, about 0.74.

**Amount of Water absorbed by Roots.**¶ — In the case of *Musanga Smithii*, a tree 20–25 m. high, belonging to the Urticaceæ, growing in French Congo, M. H. Lecomte was able to measure the amount of water

\* 'Beitr. z. Kenntn. d. Assimilations-Thätigkeit d. Blätter,' Bonn. See Bot. Ztg., lii. (1894), 2<sup>te</sup> Abtheil., p. 250.

† Bull. Sci. France et Belg., 1893. See Bonnier's Rev. Gén. de Bot., vi. (1894) p. 310. ‡ Bot. Gazette, xix. (1894) pp. 149–57, 191–9, 229–36.

§ Cf. this Journal, ante, p. 590.

|| Comptes Rendus, cxvii. (1893) pp. 756–9, 813–6. Cf. this Journal, 1893, p. 214.

¶ Op. cit., cxix. (1894) pp. 181–2.

exuded from the cut trunk in the rainy season when the air was saturated with moisture. He found it amounted to the enormous quantity of 0·711, 0·587, and 0·360 litres per hour respectively at three different periods of the twenty-four hours, viz. night, morning, and afternoon.

### (3) Irritability.

**Mechanism of the Flowers of *Schizanthus*.**\*—Herr O. Juel describes the process by means of which the stamens of *Schizanthus* spring suddenly forward when the flower is visited by an insect, covering its abdomen with pollen. The channel of the corolla, in which the stamens lie, is clothed with a layer of glandular hairs, the terminal cells of which are imbedded in mucilage. This forms a viscid layer which causes the filaments to adhere to the lower lip. But a slight pressure, such as is caused by the contact of an insect, releases the filaments from their confinement, and tension causes them to spring into an erect position.

**Movements of the Stamens of *Berberis*.**†—M. G. Chauveaud has investigated the mechanism of the movements of the stamens of *Berberis*, which he attributes to irritability of the protoplasm, not to the presence of an intercellular substance, as suggested by Pfeffer. Within the fibrovascular bundle of the filament is a special tissue composed of about two layers of elongated cells, the transverse walls of which are thin, while the longitudinal walls are thick, but with numerous thin spots. This elastic tissue is covered by a layer which is a continuation of the epiderm on the internal and lateral faces of the filament, and consists of rounded thin-walled cells. This layer of cells is the active element in the movements of the stamens. When in a state of repose the protoplasm in each cell is collected into a thick band attached to its base. Under the influence of any mechanical or chemical irritation, this band stretches and curves so that its central portion presses against the outer wall of the cell, and causes it to curve in such a way that the cell becomes shorter and thicker.

**Leaf-movement in *Cercis*.**‡—Mr. S. G. Wright has studied the leaf-movements in *Cercis canadensis*. He finds prominent enlargements at both the upper and lower end of each petiole; but the former only appears to take part in the movements. This pulvinus is composed of parenchyme, collenchyme, bast, and woody tissue. The motile organ appears to result from cell-division in the parenchymatous tissue; under the influence of light a daily movement takes place in the lamina to the extent of nearly 100°. The rise begins about 3 A.M., and continues rapidly till 9 A.M. A slight decline then occurs, after which the lamina rises to its full diurnal position about 2 P.M. A rapid fall then takes place, the full sleep position being reached about 10 P.M.

**Compass Plants.**—Mr. T. Meehan § explains the changes in position in the leaves of compass-plants—*Silphium laciniatum*, *Lactuca Scariola*, *Gaura parviflora*, *Chrysopsis villosa*—as the result of a twist caused by a somewhat prolonged effort of spiral growth, without any reference to heliotropism.

\* Ofv. K. Vetensk. Akad. Förh. Stockholm, li. (1894) pp. 67-72 (2 figs.) (German).

† Comptes Rendus, cxix. (1894) pp. 103-5.

‡ Bot. Gazette, xix. (1894) pp. 215-24 (2 pls. and 1 fig.).

§ Tom. cit., pp. 158-9.

Mr. J. C. Bay,\* on the other hand, maintains that the torsions are physiological, and asserts that the position of the leaves is entirely dependent on light; the leaves have a tendency to present their upper surface at right angles to the incident rays of light.

(4) Chemical Changes (including Respiration and Fermentation).

**Formation and Transformation of Carbohydrates.**†—Sig. A. Marcacci confirms the statement of Brown and Morris,‡ and that of Lindet§ that, in the process of assimilation the formation of sugar precedes that of starch; but points out that the same result was arrived at by himself three years earlier. He affirms, however, that the formation of saccharose is preceded by that of glucose, and this by that of formic aldehyde.

**Diastatic Ferment.**||—Herr F. Schleichert confirms the observation that the formation of starch is frequently effected by free diastase, especially in seedlings which contain abundance of starch; while in other cases it appears to be formed directly from the protoplasm. He also confirms the presence of diastase in bacteria.¶ In the pure state diastase forms a white or yellowish-white powder, soluble in water or glycerin, but insoluble in absolute alcohol. On heating it gives off the characteristic odour of burning albuminoids.

**Influence of Light on Respiration.\*\***—According to Herr F. Aereboe, the respiration of Fungi (fructification of *Agaricus campestris*) is feebler in the light than in the dark; in the case of flowering plants (petals, roots, and seedlings) no decisive results were obtained as to a periodical change in the intensity of the decomposition of carbonic dioxide dependent on light. Respiration was lowered equally by a removal from the light into the dark and from the dark into the light.

**Respiration of Plants in the Shade.††**—M. Mayer confirms the statement of Géneau de Lamarlière that plants which grow well in the shade, such as *Saxifraga sarmentosa*, *Tradescantia zebrina*, and *Aspidistra elatior*, display a much feebler power of respiration than those which thrive only when fully exposed to the sun.

**Intramolecular Respiration.‡‡**—From experiments on a large number of seeds and seedlings, Herr N. v. Chudiakow derives the law that an increased temperature has the same stimulating effect on intramolecular respiration as it has on the production of carbon dioxide, but acts with greater intensity. The optimum temperature appears to be near the maximum at which life is still possible.

\* Tom. cit., pp. 251-2.

† Malpighia, vii. (1894) pp. 459-65.

‡ Cf. this Journal, 1893, p. 660.

§ Cf. this Journal, ante, p. 230.

|| Nova Acta K. Leopold-Carol. Deutsch. Acad. Naturf., lxii. (1893) 88 pp. See Bot. Centralbl., lviii. (1894) p. 166.

¶ Cf. this Journal, 1893, p. 371.

\*\* 'Unters. üb. d. directen u. indirecten Einfluss d. Lichtes auf d. Athmung d. Pflanzen,' Heidelberg, 1893, 35 pp. and 1 pl. See Bot. Centralbl., lix. (1894) p. 182.

†† Landwirths. Versuchs-Stat., xl. See Bonnier's Rev. Gén. de Bot., vi. (1894) p. 314. Cf. this Journal, 1893, p. 351.

‡‡ Landwirthsch. Jahrb., xxiii. (1894) pp. 333-90 (26 figs.). See Bot. Centralbl., lix. (1894) p. 283.

## 7. General.

**Luminous Plants.\***—M. H. Gadeau de Kerville enumerates the plants in which luminosity has been observed, which he classifies under four heads :—(1) Fungi ; (2) Bacteria ; (3) Mosses (*Schizostega osmundacea*) ; (4) Flowering plants, viz. the rhizome of some Indian grasses, the latex of *Euphorbia phosphorea*, the leaves of *Phytolacca decandra*, and many flowers. In the flowers the luminosity is not constant, but appears in flashes in the dark, and is probably connected with atmospheric electricity ; while in the fungi and bacteria it is dependent on a vital process going on in the protoplasm.

**Purification of Streams by Chlorophyllous Plants.†**—It is a well-known fact, says Dr. T. Bokorny, that green plants can take up and assimilate organic substances, and it seems equally indubitable that water-bacteria have a share in the purification of water, and that bacteria play a very important part so long as the water contains a considerable quantity of organic matter. To what extent green plants share in the purification of streams the author determined to test by experiment. It had previously been shown that phanerogamic plants can use as nutriment organic substances such as sugar, glycerin, &c. ; and the author chiefly occupied himself with the behaviour of Algæ, especially Diatomaceæ, as regards putrefaction products and urine. Volatile fatty acids, amido-acids, indol, scatol, phenylacetic acid, urea, &c., were exposed in suitable solutions, with free access of light, and with exclusion of light, to the action of Algæ. The results were positive ; for Algæ were found capable of using as nutriment volatile fatty acids, such as butyric and valerianic, and also glucose, leucin, and tyrosin. Even urea when properly diluted could be assimilated. It may therefore be upheld that a considerable number of organic substances which are carried into rivers by drains are destroyed by water plants, though it must be remembered that water-bacteria are responsible for a large share of the work. Both co-operate, and by their united action free streams from dissolved organic matter.

**Spontaneous Purification of River Water.‡**—After alluding to the condition of the Seine about Paris, and the quantity of impurities deposited in the river from the city, M. Duclaux shows that lower down the river has again become practically pure. The case of the Isar, which flows by Munich, the condition of which was examined by Prausnitz, is mentioned here in detail. Prausnitz found that water entering Munich contained 305 germs per ccm., while 7 kilometres below there were 12,600. By the time the stream reached 33 kilometres from Munich, which it did in 8 hours, the number of germs had diminished by five-sixths.

The causes of this purification, says the author, are both physical and vital. Among the physical, one principal action is that of the ground waters which mingle with the stream along its course. These influence purification partly from their lower temperature in summer

\* Weber's Naturw. Bibliothek, 1893, 242 pp. and 27 figs. See Bot. Centralbl., 1894, Beih., p. 228.

† Arch. f. Hygien., xx. (1894) No. 2. See Centralbl. f. Bakteriöl. u. Parasitenk., xvi. (1894) pp. 91-2.

‡ Ann. Inst. Pasteur, viii. (1894) pp. 117-27.



and partly from their chemical composition. Another prominent physical source of purification is the deposit of floating particles, all of which, on account of their density, tend to fall to the bottom. These not only subside, but in the course of their precipitation drag other bodies with them. This action is aided by the molecular adhesion of water and the particles, and from this several methods have been devised for the artificial purification of water, such as Clark's and Anderson's, in which chalk and sesquioxide of iron are used. But the purification of water is effected more surely when an organic or mineral precipitate is formed than when the microbes are left simply to the action of gravity or of molecular adhesion. The principal agent in the purification is, however, the microbe, which restores to the inorganic world the elements of living matter; the part played by organisms is the principal one, the rôle of the physical actions is subsidiary.

## B. CRYPTOGRAMIA.

### Cryptogamia Vascularia.

**Vegetative Organs of Vascular Cryptogams.\***—M. G. Poirault enters into various details respecting the structure of the root, stem, and leaf of Filices, Marattiaceæ, and Ophioglossaceæ.

With regard to the root, several species of *Oleandra* present structures resembling the rhizophores of the Selaginellaceæ. With the exception of *Botrychium* and the Ophioglossaceæ, all Vascular Cryptogams belonging to these classes have root-hairs. While aerial roots possess a cuticle, those growing in the soil have it replaced by a mucilaginous layer. *Ceratopteris thalictroides* has roots which penetrate the cortex. The cell-walls of the roots of many ferns possess wart-like protuberances. Those of the endoderm are characterized by remarkable projections. The pericycle is always composed of parenchymatous elements. The phloem-fibres of the vascular bundles consist of phloem-cells and sieve-tubes; the former are elongated, and contain a large nucleus and abundant protoplasm. In the xylem the vessels are usually arranged in a band, of which the two extremities constitute the protoxylem, and the central portion the deuteroxylem. There may or may not be a metaxylem; it is wanting in the roots of the Marattiaceæ and Ophioglossaceæ. The root-buds are described in detail, especially in the Ophioglossaceæ. They are of endogenous origin.

In the stem, the sclerotized cells in the cortex are very remarkable.

In the leaves strands of protoplasm connecting the cells occur very commonly, not only between the elements of the same, but even between those of different tissues. Crystalloids occur in a very large number of species, especially in the Polypodiaceæ and Cyatheaceæ. Crystals of calcium oxalate are also widely diffused.

### Muscineæ.

**Respiration and Assimilation in Muscineæ.†**—M. B. Jönsson has studied twenty-five species of mosses, *Sphagnums*, and Hepaticæ, and

\* Ann. Sci. Nat. (Bot.), xviii. (1894) pp. 113-256 (43 figs.).

† Comptes Rendus, cxix. (1894) pp. 440-3.

finds great differences in the intensity of respiration and assimilation. The greater the proportion of water which they contain, the more intense is the gaseous interchange with the atmosphere. Specimens from a very damp locality give off more gas than others of the same species living on dry soil. The reddish colour of many, increasing in abundant light, has the effect of diminishing the intensity of respiration and assimilation.

**Elaters of Hepaticæ.\***—Miss Josephine E. Tilden describes the structure of the elaters in several genera of Hepaticæ. When young they appear always to contain starch, which usually disappears when the spiral bands are formed, but sometimes remain in the mature elater. They not unfrequently branch. The branched elaters of *Conocephalus conicus* are specially described; they occur also in *Targionia*, *Anthoceros*, and *Radula*. The branching does not take place until the pressure within the sporogone is relieved by the loosening of the spores and elaters, preparatory to their being set free. The number of spiral bands in the walls of elaters varies from one to five; they display branching and fusion. In *Conocephalus conicus* there are, as a rule, two spiral bands, one or both of which generally branch.

**Revivification of Grimaldia.†**—Sig. O. Mattiolo has proved experimentally that *Grimaldia dichotoma* Raddi may survive being subjected to a very thorough desiccation for thirteen months, and states that other Marchantiaceæ will revive after having remained in a state of latent life in dry air for seven years. He brings together a number of analogous cases, refers to revival of desiccated animals, and bows before the problem.

#### Characææ.

**Action of External Influences on the Characææ.‡**—Herr J. Richter has carried out a series of experiments on the effects of changes in the environment of the Characææ, especially *Chara fragilis* and *hispida*.

The shoots of both these species were found to be negatively geotropic and positively heliotropic. The curvatures take place chiefly in the young growing internodes. The removal of the apex retards the growth of the shoot. Rhizoids are produced on injured shoots when those already existing are removed. Even the smallest nodes can, when isolated, produce rhizoids. Their growth may be incited by surrounding the shoot with earth, or by darkening, but not by contact-irritation alone. The rhizoids are positively geotropic, but not distinctly heliotropic nor aerotropic. The "naked-footed branches" are formed on shoots or separate nodes when these have been deprived of their normal growing point, or by covering up with earth; "pro-embryonic branches" under similar conditions, but less frequently. The faculty of producing new shoots resides in the nodes only. *C. fragilis* will thrive in water containing 1.5 per cent. of sodium chloride.

**Monograph of Characææ.§**—Herr F. Filarszky has published a monograph of the Characææ, of which he makes forty-nine European

\* Minnesota Bot. Studies, 1894, pp. 43-53 (2 pls.).

† Atti R. Accad. Lincei (Rend.), iii. (1894) pp. 579-84.

‡ Flora, lxxviii. (1894) pp. 399-423.

§ SB. K. Ung. Naturw. Gesell. Buda-Pest, Jan. 3, 1894. See Bot. Centralbl., lviii. (1894) p. 229.

species. He includes the Characeæ under Algæ, placing them among the Chlorophyceæ.

**Fossil Chara.\***—Under the name *Chara Stantonii* Mr. F. Knowlton describes a new fossil species obtained from the Upper Chalk; therefore one of the oldest species from a geological point of view.

### Algæ.

**New Parasitic Alga.†**—Under the name *Pogotrichum hibernicum* sp. n. Prof. T. Johnson describes a brown alga parasitic on *Alaria esculenta* at Kilkee. It exhibits a mode of propagation by means of stoloniferous endophytic hyphæ. Both unilocular and plurilocular sporanges were observed. The author suggests the union of the two genera *Pogotrichum* and *Litosiphon*, and possibly the identity of *P. hibernicum* with *L. Laminiarix* Harv.

**Karyoid, a new Organ of Conjugatæ.‡**—In various species of *Mougeotia*, *Spirogyra*, *Zygnema*, *Closterium*, and *Cosmarium*, Herr E. Palla finds peculiar bodies, to which he gives the name *karyoids*. They were not found in any alga not belonging to the Conjugatæ. They are minute spherical bodies, 1.5 to 2.5  $\mu$  in diameter, attached to the chlorophyll plate (not imbedded in it), and are distinguished from the nucleus and the pyrenoids by their staining reactions, as also from Crato's physoids. They take up iodine-eosin and picrin-anilin-blue readily.

In *Mougeotia* these bodies are seated on both sides of the chlorophyll-plate; in *Spirogyra* only upon the inner side, where their number is extraordinarily large. In *Zygnema* they are found on the central portion only of the chloroplast, not on its rays; in *Closterium moniliferum* chiefly on the chlorophyll-band which connects the two half-cells. In *Cosmarium Botrytis* there are a number of karyoids on each of the four chloroplasts; in *C. Meneghinii* only a few minute ones, about 0.5  $\mu$  in diameter, in each half-cell.

**Trentepohlia.§**—In a paper on certain species of *Trentepohlia*, M. E. de Wildeman maintains that neither the size of the cells nor the mode of fructification can be relied on in the determination of species. On the same filament may often be found several kinds of reproductive cells. A new species, *T. Pittieri*, is described from Costa Rica.

**Pleodorina, a new Genus of Volvocineæ.||**—Mr. W. B. Shaw has found, in a ditch in California, a motile organism which he describes as *Pleodorina californica* g. et sp. n., allied to *Pandorina* and *Eudorina*. It is a cœnobe composed of about 128 biciliated cells, from one-half to two-thirds of which are parthenogonids. It is enclosed in a hyaline gelatinous envelope. There are no connecting filaments between the cells; each contains a red pigment-spot. No mode of sexual reproduction was observed. Non-sexual propagation takes place by gonids,

\* Bot. Gazette, xviii. (1893) pp. 141-2 (3 figs.).

† Scient. Proc. R. Dublin Soc., viii. (1893) pp. 1-10 (1 pl.).

‡ Ber. Deutsch. Bot. Gesell., xii. (1894) pp. 153-62 (1 pl.).

§ Ann. Soc. Belge Micr., xviii. (1894) pp. 1-31 (3 pls.). Cf. this Journal, ante, p. 233.

|| Bot. Gazette, xix. (1894) pp. 279-83 (1 pl.).

which are formed by increase in size of some of the cells. The daughter-cœnobes escape from the parent-cœnobe as spheres of similar biciliated cells.

Mr. D. M. Mottier and Mr. G. P. Clinton\* have found the same organism in Indiana and Illinois respectively.

#### Fungi.

**Influence of the Tension of Aqueous Vapour on the Growth of Fungi.**†—As the result of a series of experiments on mould-fungi (especially *Penicillium glaucum*), M. P. Lesage states that these organisms are sensible to very slight differences in the tension of aqueous vapour; an increase of moisture promotes their growth when the temperature remains the same.

**New Genera of Chytridiaceæ.**—In the oogones of *Vaucheria sessilis* and *terrestris*, Prof. W. Zopf‡ finds a parasitic organism, which he makes the type of a new genus of Chytridiaceæ under the name *Latrostium comprimens*. It occurs in the form of roundish resting-spores between the wall of the oogone and the oosphere; and of lens-shaped zoosporanges occupying a similar position, from which escape a large number of minute zoospores. *Latrostium* is nearly allied to *Rhizophilidium*, but differs in the form of the zoosporanges and resting-spores (both lens-shaped at a certain stage); in the zoospores having their cilia in front during swarming; in the zoospores not having the jerking movement of the Rhizophidicæ; and in the greater thickness of the membrane of the resting-spore.

M. A. Prunet§ finds the corn in the south-west of France attacked by a parasitic fungus belonging to the section Cladochytriciæ of Chytridiaceæ, to which he gives the name *Pyroctonum sphaericum* g. et sp. n. The genus differs from others of the family in the form of the zoosporanges, which is usually ovoid or pyriform; in their mode of opening by an apical pore; and by the ordinary zoosporanges being accompanied by others which are resting zoosporanges or cysts, usually smaller and nearly spherical.

**Woronina.**||—Prof. W. Zopf has made a careful study of the life-history of *Woronina glomerata*, parasitic on *Vaucheria*. The organism partakes of the distinguishing character of the family Woronineæ of Synchytriaceæ, the cycle of development consisting of two stages, one of which terminates with the production of swarm-forming cysts, the other with that of simple resting-spores. The first form is produced only immediately after the disappearance of the ice, later both together, and finally only the second. The resting-spores are found in the *Vaucheria*-filaments collected into sori. They have a finely sculptured surface, and appear to be formed from a plasmode. The resting-spore becomes a zoo-sporange or swarm-cyst, its contents breaking up into swarm-

\* Tom. cit., pp. 383-4. † Comptes Rendus, cxviii. (1894) pp. 607-10.

‡ Beitr. z. Phys. u. Morph. niederer Organismen (Zopf), Heft 4 (1894) pp. 62-5 (1 pl.).

§ Comptes Rendus, cxix. (1894) pp. 108-10.

|| Beitr. z. Phys. u. Morph. niederer Organismen (Zopf), Heft 4 (1894) pp. 43-60 (1 pl. and 3 figs.).



spores. The exact structure of the swarm-spores could not be determined. A peculiar mode of conjugation between two resting-spores was in some cases observed. The whole course of development the author believes to be as follows:—The resting spore becomes, after hibernation, a swarm-forming cyst, from which escape a number of small zoospores which penetrate into the *Vaucheria* filament. Here they pass into an amœboid condition. The amœbæ are nourished by the chlorophyll and other contents of the host, and develop into large plasmodes, which subsequently divide. These fragments then round themselves off, and become cysts with very thin membranes. In these thin-walled cysts a number of swarm-spores are produced, which escape into the surrounding water. These penetrate into other *Vaucheria* filaments, and the cycle of development is complete.

The property which *Woronina* possesses, in its plasmode stage, of taking up solid substances by means of pseudopodes, and of excreting the undigested ingesta, appears, to the author, to determine its position in the animal rather than in the vegetable kingdom. He places it in the family of Monadineæ zoosporeæ, which he divides into three groups, the Pseudosporeæ, Gymnococcaceæ, and Plasmodiophoræ, of which *Woronina* belongs to the second.

**Brefeld's Mesomycetes.\***—Prof. W. Zopf adduces arguments against the system of Brefeld which establishes, as a primary group of fungi, the Mesomycetes, again divided into the Hemiasci and Hemibasidii (Ustilagineæ). He contests Brefeld's assertion that the structure which De Bary calls promycele in the Ustilagineæ is, in reality, of the nature of a basid; there are, in fact, a large number of forms in which it is altogether wanting. He disputes also the validity of the distinction drawn by Brefeld between the ascus of the Ascomycetes and the sporange of the Phycomycetes, from the constancy or inconstancy of the number of spores. There are many Ascomycetes in which the number of the ascospores in the ascus is inconstant, and many Phycomycetes in which the number of spores in the sporange is constant.

**Sexual Reproduction in the Ustilagineæ.†**—M. P. A. Dangeard has further studied this subject in the case of *Entyloma Glaucii*. The fusion of the two nuclei within the oogone was clearly observed; they are suspended in its centre by trabecules of protoplasm; at the spot where they come into contact with one another the two nuclear membranes disappear, and the two nucleoles subsequently coalesce. The oosperm then contains a single central nucleus; the protoplasmic trabecules form large vacuoles, and the membrane becomes stratified into two layers.

**Sexual Reproduction among the Ascomycetes.‡**—M. P. A. Dangeard has pursued his investigations on this subject, both among the Exoasci and the Carpoasci (Discomycetes, Pyrenomycetes, and Peri-

\* Beitr. z. Phys. u. Morph. niederer Organismen (Zopf), Heft 3 (1893) pp. 1-14 (4 figs.). Cf. this Journal, 1892, p. 400.

† Le Botaniste (Dangeard) iv. (1894) pp. 12-7 (3 figs.). Cf. this Journal, ante, p. 485.

‡ Le Botaniste (Dangeard) iv. (1894) pp. 21-58 (10 figs.). Cf. this Journal, ante, p. 486.

sporiaceæ). The process in *Peziza vesiculosa* he regards as typical of that which takes place in the whole group. The asci are developed from oosperms which result from the anastomosing of conjugating filaments or gametes, each of which has a single nucleus. In *Exoascus deformans* the cells (oosperms) from which the asci are produced contain two nuclei; otherwise the process is the same. In the Discomycetes examined the oogone rests on two mycelial filaments. In the Pyrenomycetes it arises on the stroma in the form of a simple papilla. The oogones always contain two nuclei.

The ascus of the Ascomycetes is analogous to the promycele of the Uredineæ and Ustilagineæ. The two organs have the same origin in an oosperm; they behave in the same way during the division of the sexual nucleus. The only difference between the organs is a physiological one. In the Ascomycetes the embryos (ascospores) remain within the ascus; while in the Uredineæ and Ustilagineæ they become external, budding out on the surface of the promycele. In the one case they are endogenous, in the other exogenous.

**Sclerote-forming Species of *Penicillium*.**\*—Dr. C. Wehmer classifies the known species of *Penicillium* into five groups with respect to the mode of fructification, viz.:—(1) Those which form conids only (most of the known species); (2) With soft fructification, and of comparatively homogeneous structure, without any special cortex or long period of rest (*P. luteum, aureum*); (3) With perithece-like fructification, and a special thin cortex (*P. insigne*); (4) With hard fructification or sclerote, which develops only after a period of rest (*P. glaucum*); (5) With a hard sclerote which undergoes no further development (*P. italicum* sp. n.). The new species, found on oranges and causing their decay, is described in detail. It follows from the above that the character of the fructification cannot be relied on as a generic diagnosis.

**Sclerote in Alder-fruit.**†—Herr R. Maul describes a sclerote formed in the fruit of the alder by an unknown species of fungus. He states that sclerotes may be either pure saprophytes, facultative parasites, or necessary parasites. The only sclerotes at present fully known belonging to the last class are those of *Claviceps* (ergot), and of the berries of *Vaccinium*. To this class belongs also the new *Sclerotinia Alni*, the infection of which must probably have taken place in the ovary. It differs from other sclerotes in the cortex and medulla consisting of a nearly homogeneous mycele, the hard pericarp of the alder-fruit affording it that protection during its resting period which is given to other sclerotes by their hard cortex. It presents also the peculiarity, shared at present only by *Sclerotinia Fuckeliana*, of the conids being formed directly from the sclerote, without any further form of fructification.

**Wine-Yeasts.**‡—MM. P. Hautefeuille and A. Perrey have investigated the yeasts that produce fermentation of wine (Côtes de Nuit and Beaune). They may be divided into three groups. The first group consists of apiculate yeasts which produce fermentation at the outset, and in some cases complete it. The second consists of ellipsoidal yeasts more active

\* Hedwigia, xxxiii. (1894) pp. 211-14. † Tom. cit., pp. 215-28 (2 pls.).

‡ Comptes Rendus, cxviii. (1894) pp. 589-91.

than the first group; they complete the fermentation, and, in the later stages, completely displace the apiculate forms. The third group also consists of ellipsoidal yeasts which, in a neutral or slightly acid must, behave rather like high yeasts, and acquire a rose or wine-red coloration; they appear to have but little activity, but show marked power of sporulation during their most active period.

**Structure of Yeasts and their Development.\***—The question whether yeasts have a nucleus or not has long been in dispute. M. P. A. Dangeard, from examinations of Ustilagineæ, decides in favour of a nucleus which is constantly present, surrounded by a doubly contoured membrane, and containing an evident nucleole. Abutting on the cell-membrane which encloses a thick layer of protoplasm lies the nucleus, so long as it is at rest. In the budding the nucleus plays a passive part. The young cell possesses a protoplasmic layer like the mother-cell, to which it is attached by a fine sterigma. The nucleus gets engaged in the passage to the new cell, and dividing, one part passes through the sterigma into the daughter-cell. The nuclear membrane and nucleole appear later.

With regard to the systematic position of the Saccharomycetes, the author says that if his investigations upon the histology of the Ustilagineæ support Brefeld's views, it must be borne in mind that they do not controvert the conclusions which may be drawn from the presence of spores in *Saccharomyces*. As to the appearances obtained by Hieronymus,† who instead of a nucleus found a central thread, the author regards them as due to insufficient fixation of the material.

**Action of Yeasts on Glycogen.‡**—Herren A. Koch and H. Hosæus, who have been experimenting with yeasts on animal and vegetable glycogen, find that this substance exerts a markedly inhibitory influence on the production of alcohol. The glycogen was obtained from calves' and rabbits' livers, and from starch-free German yeast. The yeasts used in the fermentation experiments were brewers' yeast, Froberg yeast, and German yeast. The authors conclude that the presence of glycogen in a nutrient solution does not augment the multiplication of yeast, as occurs in otherwise suitable media, e. g. dextrose.

Even small quantities of glycogen do not disappear from a nutrient solution exposed to the influence of yeast, though they vanish quickly if bacteria contaminate a solution, which no longer shows the glycogen-iodine reaction. None of the added glycogen is absorbed by the yeast-cells, and not any of the three kinds of yeast were able to make alcohol out of it. All the kinds of glycogen employed in the experiments exhibited the noteworthy property of diminishing both the yeast production and the amount of alcohol, not only on suitable (beer-wort) but on unsuitable media (meat extract). The three varieties of glycogen used, which were prepared from the liver of rabbits and of calves and from German yeast, according to Külz's method, behaved exactly alike qualitatively, and only exhibited trivial differences in the amount of yeast-increase when compared quantitatively.

\* *Le Botaniste*, iii. (1894) pp. 282-6 (2 figs.). Cf. this Journal, *ante*, p. 95.

† Cf. this Journal, 1893, p. 509.

‡ *Centrallbl. f. Bakteriol. u. Parasitenk.*, xvi. (1894) pp. 145-58.

**Spore-forming Saccharomyces.\***—Mr. C. Bay describes twenty-two species of *Saccharomyces* in which the formation of spores has at present been observed. The form of the spores, the conditions under which they are produced, and the physiological properties of the species, are given in detail; and these observations are, in conclusion, arranged in a tabular form.

**Pedicel<sup>†</sup> of the Teleutospores of Puccinieæ.†**—M. P. Vuillemin points out that it is frequent, in the teleutospores of the Puccinieæ, for the outer layer of the cell-wall of the spore to be continued, without a break, over the pedicel, preserving the same structure. The pedicel is often of great length, and carries on an independent existence after the fall of the spore. It may even put out a germinating filament. A new species of *Uromyces* is described, *U. verrucipes*, parasitic on *Euphorbia Peplus*.

**Heterœcious Uredineæ.‡**—Herr H. Klebahn records the following additional observations:—

*Peridermium oblongisporium* belongs to the cycle of development of *Coleosporium Senecionis*; *S. Stallii* to that of *C. Euphrasie*; *P. Plowrightii* to that of *C. Tussilaginis*. *C. Alektorolophi* belongs to *P. Stallii*.

*Puccinia Laricis* produces *Æcidium Urticæ* on *Carex dioica* and *C. Goodenoughii*. *P. coronata* produces *æcidia* on *Rhamnus Frangula*, uredo- and teleutospores on *Agrostis vulgaris*, *Calamagrostis lanceolata* and *arundinacea*, and *Holcus lanatus* and *mollis*; while the nearly allied *P. coronifera* sp. n. produces *æcidia* on *Rhamnus catharticus*, uredo- and teleutospores on *Holcus lanatus*, *Arrhenatherum elatius*, *Festuca elatior*, and *Lolium perenne*. *P. Prailii* produces *æcidia* on *Rumex Acetosa*, but not on *R. crispus*, and is therefore distinct from *P. Phragmitis*. *Æcidium Periclymeni*, sown on *Festuca ovina*, gave rise to *Puccinia Festucæ*.

**Parasitic Fungi.**—Sig. V. Peglion § describes two diseases of the melon, one due to the attacks of a pathogenic fungus, *Alternaria Brassicæ* f. *nigrescens*, the other to an acarus, *Tetrarhynchus telarius*, the latter also attacking *Citrullus vulgaris*.

Sig. A. N. Berlese || treats of a disease of the chestnut shown by the premature falling of the leaves, caused by the attacks of a parasitic fungus, the conidial stage of which is known as *Cylindrosporium castanicolum*, the spermatogone stage as *Phyllosticta maculiformis*.

The same author ¶ finds both the leaves and fruit of the fig attacked by *Cercospora Bolleana*, and the fruit by *Uredo Fici*.

Herr F. Krüger \*\* describes in detail the injuries caused in the turnip by *Phoma Betæ*, to which he attributes the two diseases known as *Herzfäule* and *Wurzel-brand*. According to Sorauer (*loc. cit.*), the

\* Amer. Natural., xxvii. (1893) pp. 685-96.

† Bull. Soc. Bot. France, xli. (1894) pp. 285-90.

‡ Zeitschr. f. Pflanzenkrankheiten, 1894, pp. 7, 84, 129 (1 pl.). See Bot. Centralbl., lix. (1894) p. 334. Cf. this Journal, 1893, p. 511.

§ Riv. di Patologia Vegetale, ii. (1893) pp. 227-40. See Bot. Centralbl., lix. (1894) p. 47.

|| Tom. cit., pp. 194-226. See Bot. Centralbl., lix. (1894) p. 48.

¶ Tom. cit., pp. 251-3. See Bot. Centralbl., lix. (1894) p. 117.

\*\* Zeitschr. f. Pflanzenkrankheiten, iv. (1894) pp. 13-20. See Bot. Centralbl., lix. (1894) p. 117.



first of these diseases of the turnip may also be caused by *Sporidesmium putrefaciens*.

The injuries inflicted on the wild and cultivated strawberry—chiefly on the leaves and to a less extent on the stem—by *Sphærella Fragariæ* are described by Sigg. E. Baroni and G. Del Guercio.\*

Miss I. Clendenin † describes a species of *Synchytrium*, probably *S. Stellariæ*, parasitic on *Stellaria media* in Louisiana.

Sig. G. Del Guercio ‡ finds large numbers of *Caloptenus italicus*, in the Florentine territory, killed by the attacks of a fungus belonging to the Entomophthoraceæ, probably *Empusa Grylli*.

**Diseases of the Sugar-cane.**§—In addition to a number of diseases caused by nematode worms in the sugar-cane in New South Wales, Dr. N. A. Cobb describes one due to microbes—gumming, caused by *Bacillus vascularum*—and five due to Fungi, viz. : cane-rust (*Uromyces Kühnii*); cane-spume, a new term (*Strumella Sacchari*); cane-soot (*Macrosporium graminum*); cane-freckle, erroneously called rust (accompanied by *Phoma Sacchari* and a *Botrytis*, but of uncertain origin); and red-rot of the cane (caused by an unnamed parasitic fungus).

Herr F. A. F. C. Went || maintains that the “sereh” disease of the sugar-cane is not due, as has been stated, to a pathogenic Schizomycete, although the ubiquitous *Bacillus subtilis* is always found in the gummy exudation, but probably to an undescribed fungus, *Hypocrea Sacchari* sp. n. He also ascribes a new disease of the sugar-cane to another undescribed fungus, *Colletotrichum clavatum* sp. n. The so-called “pine-apple” disease of the sugar-cane he attributes to the attacks of a parasitic or saprophytic fungus which he makes the type of a new genus, *Thievalopsis ethaceticus*. The peculiar aromatic odour is due to the formation of ethyl acetate.

**Parasites of the Mushroom.**¶—MM. J. Costantin and L. Matruchot describe in detail the structure of the fungi which produce the destructive diseases of the mushroom known as *vert de gris* and *plâtre* (*Myceliophthora lutea* and *Monilia fimicola*). Both are true parasites; the former is propagated by conids and chlamydo-spores, the latter by conids only. The mode in which they affect the host is described in detail, and the best mode of combating their attacks is pointed out.

**Systematic Position of Ditiola.**\*\*—From a careful examination of the rare *Ditiola radicata*, found growing on pine-wood, Herr G. Lindau comes to the conclusion that the genus must be placed among Daeromycetes, intermediate between *Dacryomitra* and *Guepinia*.

**Fixity of Race in Mushrooms.**††—MM. J. Costantin and L. Matruchot communicate some interesting experiments as to the constancy of certain

\* Nuov. Giorn. Bot. Ital., i. (1894) pp. 208-16.

† Bot. Gazette, xix. (1894) pp. 296-7 (1 pl.).

‡ Bull. Soc. Bot. Ital., 1894, pp. 89-91.

§ N.S.W. Deptmt. of Agric., Sydney, 1893, 30 pp. and 28 figs.

|| Arch. v. d. Java Suikerindustrie, 1893, 72 pp. and 4 pls. See Bot. Centralbl., lix. (1894) pp. 42-4.

¶ Rev. Gén. de Bot. (Bonnier), vi. (1894) pp. 289-300 (1 pl.). Cf. this Journal, 1893, p. 509.

\*\* Hedwigia, xxxiii. (1894) pp. 234-40 (1 pl.).

†† Comptes Rendus, cxviii. (1894) pp. 1108-11.

varietal characters in mushrooms. Connoisseurs are said to be able to pick out their favourite dainties from among the five hundred baskets brought daily to the Marché aux Halles. The growers can retain the esteemed characters as long as they can keep the same spawn or mycele in health. But the authors have proved that the varieties in question can also be reared from the spores. Five varieties have thus been proved constant when reared from spore-cultures. The whole period requires 6-7 months. Certain features, such as the colour of the pileus, its scaly or fibrillar appearance, the presence of a more or less developed velum, are hereditary characters of definite stability. But, as in the ordinary culture, so in that from spores, there are variations of size and consistence and the like. It is pointed out that artificial selection may do much in the future if applied to the races of *Psalliota*.

**Vascular Hyphæ in the Autobasidiomycetes.\***—From an examination of 55 species belonging to 33 genera of Clavariaceæ, Polyporeæ, Agaricaceæ, Tulostomeæ, Sclerodermaceæ, Lycoperdaceæ, Hymenogastree, Nidulariæ, Sphærobolææ, and Phalloideæ, M. C. Van Bambeke states that, from a morphological point of view, the mycele may assume the four following different forms:—(1) nematoid, filamentous, or floccose; (2) membranous; (3) spartioid or cord-like; (4) pseudorhizoid, or radiciform mycelial formations. The following are the results of his observations on the vascular hyphæ.

They are constantly present in the mycele of the Autobasidiomycetes. Their number, distribution, size, and form differ according to the various forms of mycele in which they occur; they are especially abundant in the spartioid form. With rare exceptions their size exceeds that of the ordinary hyphæ. The usual form is cylindrical, but considerable variations occur. The vascular hypha consists of a thin extensible and elastic envelope, the contents of which are usually homogeneous and strongly refringent, but sometimes granular. Nuclei could sometimes be detected lodged in a parietal layer of protoplasm. There are usually numerous septa. The chemical composition of the contents varies. The vascular hyphæ constitute a conducting apparatus of great importance to fungi in the distribution of nutritive substances.

**Parasitic Hymenogaster.†**—Sig. F. Cavara describes a new species of *Hymenogaster*, *H. cerebellum*, which appears to carry on, under certain conditions, a parasitic existence on the roots of Casuarinæ and Myrtaceæ, similar to that already described in the case of some Tubercaceæ and Elaphomyceetes.

**Selonosporium aquæductum (Musk-Fungus).‡**—M. R. Moniez finds this fungus very abundantly in the drinking water of Lille, which is characterized by a large quantity of lime-salts and of organic substances. It forms on the bottom cock's-comb-like bodies composed of interwoven hyphæ, with the characteristic spores on their surface, and

\* Bull. Acad. Roy. Sci. Belg., xxvii. (1894) pp. 492-4. Cf. this Journal, 1892, p. 526.

† Atti R. Ist. Bot. Univ. Pavia, iii. (1893) 18 pp. and 1 pl. See Bot. Centralbl., lix. (1894) p. 15.

‡ Rev. Mycol., 1893, pp. 140-5. See Bot. Centralbl., lix. (1894) p. 171.

containing crystals of calcium carbonate. Cultivated in a saccharine nutrient material, roundish conidia are abstracted of about  $7\ \mu$  diameter; spherical bodies are also formed about 1 mm. in diameter, which contain large quantities of spores and of lime crystals. On the mycelial filaments cell-fusions were also observed, which the author compares to the conjugation of *Spirogyra*. Swollen toruloid filaments are formed in the interior of the fluid. The infection of the water previously attributed to *Crenothrix Kühniana* he believes to be due to the *Selonosporium*.

*Actinomyces Gruberi* sp. n.\*—Dr. C. Terni describes a new species of *Actinomyces* which he found in earth. It is pathogenic to guinea-pigs, but its action is merely toxic. At the inoculation site a small abscess forms in which the germs develop. The animals die suddenly after 10–12 days, with symptoms of palsy and spasms. By attenuating the germs, a sort of vaccine was obtained. *A. Gruberi* possesses a striking tendency to the formation of pigments, varying from red to brown, though these pigments are not disseminated through the medium. The addition of glycerin to the medium is necessary for the pigment production, especially for the red and yellow colours. The author observed that spore formation very soon occurs, if developmental conditions become unfavourable (especially drying), and always at temperatures between  $20^{\circ}$  and  $30^{\circ}$ , and when access of oxygen is slight.

### Protophyta.

#### a. Schizophyceæ.

Filamentous Form of *Protococcus*.†—Miss Josephine E. Tilden describes a remarkable form of *Protococcus*, apparently *P. infusionum* var. *Rœmeriana*, found attached to an Entomostracan in submerged meadowland. Some of the *Protococcus* cells had entered the hairs of the host, and had there undergone septation into a number of cells arranged in a filament. The rows of cells bore a marked resemblance to the filaments of an *Oscillatoria*.

Parasite of *Gunnera*.‡—According to Herr B. Jönsson, the parasite *Nostoc punctiforme*, which is so commonly found within the stem of *Gunnera scabra* and *manicata*, finds its way into the cells from the copious coating of mucilage which covers the young stem and leaves, and which is formed in glandular organs beneath the base of the leaf. It is a true endophyte, and does not contribute to the nutrition of its host. A species of *Chlorococcum* was occasionally found associated with the *Nostoc*.

*Stichococcus bacillaris*.§—M. P. A. Dangeard considers that he has obtained evidence that this organism is not, as some have supposed, a Schizomycete, but an Alga; the cells contain a true nucleus. *Bacterium viride* is probably a stage in the development of the same organism.

\* Mittheil. XI. Internat. Med. Kongr. in Rom. See Centralbl. f. Bakteriol. u. Parasitenk., xvi. (1894) pp. 362–3. Cf. this Journal, ante, p. 604.

† Bot. Gazette, xix. (1894) pp. 334–5 (1 pl.).

‡ Bot. Notiser, 1894, pp. 1–20 (6 figs.). See Bot. Centralbl., lix. (1894) p. 12.

§ Le Botaniste (Dangeard) iv. (1894) pp. 1–3 (1 fig.).

## β. Schizomycetes.

**Influence of Bacterial Association.\***—M. V. Galtier, who made use of *B. anthracis*, *Str. pneumoenteritis equi*, and the microbe of fowl cholera, all previously attenuated, draws the following conclusions from his experiments. Microbes which have been attenuated down to a point when they are no longer fatal by themselves, may have their virulence restored when two species are introduced into an organism. The two microbes may multiply side by side, though usually one of them disappears or tends to disappear, while the other one becomes pathogenic. When two microbes are associated, now one, now the other recovers its virulence according to the method adopted for their introduction, and to the species of animal. This association of bacteria may be employed in the laboratory to restore virulence to attenuated microbes, and it may explain the recrudescence of certain epidemics, or the effects of vaccinations made with a benignant virus. The passage of one microbe which confers immunity against a given malady may increase the susceptibility for another.

**Leptothrix racemosa.†**—Sig. P. Vicentini gives this name to the parasite of the teeth known as *Leptothrix buccalis*, constantly found in the sputum. He adduces reasons for regarding it, not as an independent organism, but as a low stage in the development of a fungus belonging to one of the more highly developed families. In addition to propagation by means of spores and sporids, he believes he has detected a sexual mode of reproduction. The author further suggests that the organism forms a member of a biological series of development along with *Pneumococcus*, Koch's bacillus, and Neisser's *Gonococcus*.

**Polymorphism of Cladothrix.**—From experiments in cultivating *Cladothrix dichotoma* in a weak solution of extract of meat, Herr M. Büsigen argues that it is not subject to the polymorphism which has been assigned to it. Other Schizomycetes, especially a large *Spirillum*, constantly accompany it, and are liable to be mistaken for stages in its development. Neither micrococci nor endogenous resting-spores were observed. Very short rods have been mistaken for the former. Involution-forms are obtained when the supply of air is limited.

**Disease in Fresh Water.§**—M. E. Bataillon finds that a *Diplobacillus*, whose structural characters he has previously stated, is associated with a literal "peste" in fresh water. It attacks fishes, whether embryonic or adult, and the cray-fish likewise. It finds a particularly favourable medium in the spawn of fishes, and above all in the spawn of Amphibians.

**Influence of Natural Agents on Virulence of Tubercle Bacillus.||**—Drs. A. Ransome and S. Delépine find that finely divided tuberculous matter is rapidly deprived of virulence in daylight and in free currents of air; fresh air has some, though a retarded influence in

\* Comptes Rendus, cxviii. (1894) pp. 1001-4.

† Acti R. Accad. Medico-chirurgica Napoli, iv. (1893) 48 pp. and 1 pl.

‡ Ber. Deutsch. Bot. Gesell., xii. (1894) pp. 147-52 (1 pl.).

§ Comptes Rendus, cxviii. (1894) pp. 942-4.

|| Proc. Roy. Soc. Lond., lvi. (1894) pp. 51-6.



darkness; while in the absence of air or in confined air the bacillus retains its power for long periods of time.

**Action of Sea Water on Microbes.\***—According to M. P. A. Cassedebat, sterilized sea water kills *Staphylococcus aureus* in 22–24 days; *St. citreus* in 19–22 days; Friedlaender's bacillus in 35–40 days; anthrax in 21–24 days; bacilli of green diarrhoea in 16–20 days; *Spirillum Deneke* in 22–25 days; *Proteus vulgaris* in 23–26 days; typhoid bacillus in 48 hours. Cholera spirilla of various origin were still alive after 32–35 days, though in non-sterilized sea water they were defunct in a comparatively short time.

**Bacteriology of Teeth-pulp.†**—Prof. Miller finds from an examination of over 250 cases of diseased teeth, that affections of the pulp are usually the result of mixed infections, cocci and rodlets being present with fairly equal constancy, though long filaments and curved forms are not infrequent. The bacteria usually find their way to the pulp through the carious dentine, but a thin layer of hard dentine is insufficient to stop them. Suppurative conditions appear to be excited by cocci, though the typical pyogenic cocci, *Str. pyogenes aureus* and *albus* and *Str. pyogenes*, are rarely to be found in pus from the pulp; these cocci form a group of closely allied species, and have a marked pyogenic action on mice. The action of cocci on the pulp is much increased by decomposition; this in its turn must be ascribed to the action of bacteria.

**Liquefaction of Gelatin by Streptococcus pyogenes.‡**—Dr. N. Pane states that *Str. pyogenes* will liquefy gelatin at temperatures over 28° C. The nutrient medium is easy to prepare, but great accuracy is necessary. A 14 per cent. solution of gelatin is filtered through cotton previously boiled in a soda solution. It is then steam-sterilized for 5–6 minutes, and afterwards cooled down with water. In making this nutrient gelatin which liquefies at 30°, it should be borne in mind that the melting point of the gelatin falls inversely to the time during which the temperature has acted. This property of liquefying gelatin under the conditions laid down by the author may be regarded as a specific characteristic of *Str. pyogenes*.

**Immunity to Diphtheria.§**—From a series of experiments relative to artificial immunity and diphtheria, Dr. J. Kuprianow concludes that the blood-serum of rats naturally immune to diphtheria is unable to protect other animals against this disease. But by treating rats with virulent living diphtheria cultures, an immunizing power is imparted to their blood-serum, and this result is attained by injecting separately small doses, or larger ones at greater intervals, of diphtheria bouillon cultures (0.1 ccm. per diem, 1 ccm. per week, and up to 5 ccm. eventually). By the aid of the blood-serum of immunized rats, and subsequently (3–4 weeks) by injections of diphtheria bouillon cultures, guinea-pigs can be rendered immune in about three months; and with

\* Rev. d'Hyg. et de Pol. San., 1894, p. 104. See Centralbl. f. Bakteriol. u. Parasitenk., xvi. (1894) p. 265.

† Verhandl. Deutsch. Odontol. Gesellsch., vi., Nos. 1 and 2. See Centralbl. f. Bakteriol. u. Parasitenk., xvi. (1894) pp. 447–55 (27 figs.).

‡ Centralbl. f. Bakteriol. u. Parasitenk., xvi. (1894) pp. 228–30.

§ Tom. cit., pp. 415–34.

this blood-serum other guinea-pigs can be immunized to the same degree in even less time (two months).

Active immunity is developed 3 to 4 weeks after passive immunity becomes evident, and at first is very feeble. Forced immunization quite failed; and to impart a high degree of immunity to these animals, guinea-pigs, it is necessary to use very small doses at first, and these must be very slowly increased, otherwise the animal's life is in danger.

No immunity was conferred on dogs by feeding them for a long time on guinea-pigs which had died of diphtheria; nor was the result attained when the feeding was combined with treatment with heated cultures. The immunizing power of rat's serum is less than that of guinea-pigs, while that of dogs is still greater. A powerful diphtheria poison is formed in bouillon cultures in 2 to 3 weeks, provided that the reaction of the pepton bouillon be made neutral to phenolphthalein.

**Effect of Citric Acid on Diphtheria Bacillus.\***—After discussing the writings of numerous observers on the effect of citric acid on the bacillus of diphtheria, Dr. H. Laser gives his own experience. He found that 1 cem. of 50 per cent. citric acid in 10 cem. of diphtheria bouillon will kill the bacilli in 4–5 minutes. Inoculations with diphtheria bouillon cultures on the vaginal mucosa of guinea-pigs were made, and this was followed by touching up with 20 per cent. citric acid. The animals recovered so satisfactorily and rapidly that the author proceeded to try the effect on human beings. A 20 per cent. citric acid had neither a caustic nor a stringent effect. The solution was used as a gargle locally, and taken internally as a beverage. The results were encouraging.

**Sporicidal Action of Serum.†**—Dr. J. Leclef selected the spores of *Bacillus subtilis* and those of the potato bacillus to work with in an investigation as to the sporicidal action of serum. The experiments were conducted in the usual way, and the author concludes from the results that rabbit's serum, at any rate outside the body, rapidly and thoroughly destroys the spores of *B. subtilis* and those of potato bacillus. It loses this power if heated for an hour to 60°, and only exerts it in the presence of certain salts (sodium chloride). As the presence of nutritive substances does not impede the exercise of this function, it may be inferred that the death of the spores is not due to famine, but to the specific action of the serum.

The same author ‡ finds that there exists, at least *in vitro*, a close relation between the pathogenic power of microbes and their resistance to the destructive action of serum. This action was tested on ten different micro-organisms, five pathogenic and five non-pathogenic. All the ten flourished if sown on heated serum. The tables show that the organisms decrease in virulence as follows:—*Bacillus pyocyaneus*, bacillus of rabbit septicæmia, *Staphylococcus pyogenes aureus*, *Proteus*, *Bacillus coli communis*, a red coccus, a putrefactive coccus, a yellow coccus, an undetermined bacillus, *Bacillus subtilis*.

Further experiments showed that the relation between the virulence of microbes and their resistance to the bactericidal action of serum is manifested not only when a comparison is made between different

\* Hygien. Rundschau, 1894, p. 102. See Bot. Centralbl., lviii. (1894) p. 279.

† La Cellule, x. (1894) pp. 347–74 (1 pl.).

‡ Tom. cit., pp. 377–99.

organisms, but is also observable between different specimens of the same species but of unequal virulence.

**Bactericidal Power of the Body Juices.\***—With regard to the question of immunity, Prof. J. Denys takes up a position between the strict phagocytists and the strict humoralists; for while he strongly upholds the bactericidal power of serum and of lymph, yet he admits that leucocytes are capable of destroying microbes. It is needless to remark that his position is not agreeable to the chiefs of the two opposing schools, and in a short memoir the author replies to Buchner and Metschnikoff. The humoralist is displeased with the author for asserting that dog's serum has very little bactericidal action, but that the leucocytes have, and would explain the absence of this power by an alteration produced in the blood by filtration. But the author replies that the germicidal action reappears if leucocytes be restored, and that this action is proportional to the number present. Though the author accepts phagocytosis, or rather makes use of the term, the phagocyte is not to him destructive in virtue of its military powers, but from its power of secreting a poison, leucocidine.† This phagocyte is therefore equivalent to a wandering gland. The objections of Metschnikoff, four in number, are then dealt with. The first of these is that the so-called bactericidal action is due to change of medium. The second is that it requires twice as much of the germicidal substance to kill the bacteria as to scotch them. Thirdly, though blood-serum is bactericidal towards the bacilli of anthrax, the spores are unaffected. The fourth and most telling objection is that there is no relation between the bactericidal power of the body-juices and immunity; thus the serum of an animal which is, say, sensitive to a certain microbe, may be very bactericidal *in vitro*, while that of another which is unaffected by the microbe has no action whatever. The author finds that there is little ground for these objections, that the first is explained away by, among other things, the fact that certain bacteria are killed off by fresh serum, while if this serum be heated to 60° they swarm.

The replies to the second and third objections may be taken together, since they practically amount to the same thing. The author replies that spores are just as sensitive to the humours as the vegetating forms. To combat the last objection he cites the experiments of Leclef, who found that there is a strict parallelism between the pathogenic action of microbes and their resistance to humours.

The author concludes by expressing the opinion that the last word on the bactericidal power of the juices has not yet been said, and that all that we can affirm at present is that the serum of certain animals, outside the body at least, contains a toxic substance which acts on microbes after the manner of an antiseptic, causing them to perish, though surrounded by everything necessary for their well-being.

**New Frog-spawn Fungus.‡**—Drs. A. Koch and H. Hosaeus describe a new organism which was obtained from a sugar factory. When in bulk the organism presented to the naked eye a brownish jelly-like mass, recalling the appearance of *Leuconostoc mesenterioides*. By squeezing a

\* La Cellule, x. (1894) pp. 463-72.

† Cf. *infra*, p. 732.

‡ Centralbl. f. Bakteriol. u. Parasitenk., xvi. (1894) pp. 225-8 (1 fig.).



piece of the jelly under a cover-glass a mass of short, thick, twisted filaments was observed. If, however, a cover-glass preparation was made and stained in the usual way, only short thin bacteria-rodlets were found. By merely staining with methylen-blue it was seen that the thick threads remained unstained, while at one end were one or two brightly stained rodlets, the long axis of which was usually vertical to that of the thick filament. Thus it would seem that the growing part of the organism, which according to the illustrations given is Y-shaped, resemble bacteria-rodlets, and that the vegetative part secretes a jelly. The authors failed to obtain a pure cultivation of their organism, which they call *Bacterium pediculatum*.

**Pathogenic Bacillus of Frogs.\***—Under the name *Bacillus Ranarum* Sig. G. Catterina describes a new species which is pathogenic to frogs. The rods are about 2  $\mu$  long and 1  $\mu$  broad, rounded on both sides, solitary, or united into chains of three or four.

**Bacillus of Bubo Plague.†**—Dr. Yersin states that preparations made from the enlarged lymphatic glands in plague show very large numbers of a short stumpy bacillus with rounded ends, which is easily colourable with anilin dyes but not by Gram's method. The ends of the bacilli stain better than the middle, so that a clear space often remains. Not unfrequently the bacilli are surrounded by a capsule. Cultivations on gelose, glycerin gelose, serum, and bouillon do well, but the best medium is one composed of 2 per cent. alkaline peptone and 1 to 2 per cent. gelatin. Under the Microscope these cultures show chains of short bacilli, with bulgings in some places. Involution forms are common, especially in old cultivations.

Rats, mice, and guinea pigs, when inoculated with bubo pulp, always die, the bodies showing characteristic lesions together with numerous bacilli in the glands. The first cultivations on pepton agar are of slow growth, but afterwards colonies of rapid development appear, and pure cultivations of these are found to be of diminished virulence, and after a time virulence is lost. Feeding experiments showed that the bacillus was as infectious as inoculable. The organism was also found in flies and on the soil 4 to 5 cm. below the surface.

**Cholera and Vibrios.‡**—M. E. Metschnikoff discusses, in his fourth memoir on cholera, the question of immunity, and more especially occupies himself with questions bearing on intestinal cholera. He finds (1) that local immunity cannot be explained by particular conditions which prevent the microbe from living, for it may be found beyond the cholera area and in places quite free from it. (2) Local immunity cannot be regarded as an unconscious and permanent vaccination of the inhabitants. (3) The blood of persons residing in exempt places does not protect against Koch's vibrio. (4) The injection of cholera cultures does not protect. (5) The development of the cholera vibrio is considerably affected when growing in association with other microbes. (6) The immunity of animals to intestinal cholera is in great measure due to the inhibitory influence of the flora of the gastro-intestinal canal

\* Bull. Soc. Ven.-Trentina Sci. Nat., v. (1894) pp. 190-4. See Bot. Centralbl., lix. (1894) p. 214.

† Ann. Inst. Pasteur., viii. (1894) pp. 662-7 (1 pl.).‡

‡ Tom. cit., pp. 529-89 (1 pl.).



on the cholera vibrio. (7) As long as young rabbits are being suckled they are very sensitive to the cholera vibrio, and this cholera is aided by the action of certain microbes. (8) Young guinea-pigs are less sensitive than young rabbits to intestinal cholera. (9) Young rabbits cannot be vaccinated successfully against intestinal cholera, either with sterilized or living cultures. (10) Young rabbits may be occasionally vaccinated successfully by means of the serum of animals vaccinated against cholera peritonitis. Normal horse serum is useless. (11) The attempts to prevent cholera by means of microbes have shown that bacteria exist in the alimentary canal inhibitory of the cholera vibrio, but at present the results are inconclusive. (12) In the immunity and receptivity of man and animals to intestinal cholera, the microbial flora of the alimentary canal plays an important part. Relying on this fact, we may readily reconcile the fundamental truth that the vibrio of Koch is the specific cause of cholera with the data of epidemiology, especially with the influence of places and time on the progress of cholera epidemics.

**Variations of the Cholera Vibrio.\***—Herr R. Claussen gives an interesting account of transitory variation in the characters of the cholera vibrio. Microscopical examination of hanging drops showed the characteristic movements, and stained preparations the curved rodlets. Gelatin plate cultivations showed many colonies, though the edges seemed a little eroded. These colonies were composed of curved rodlets exhibiting lively movements, and the same appearances were observed in pepton-water cultivations. The nitroso-indol reaction was, however, absent. Fresh cultures on plates, tubes, and on pepton-water were made, and a guinea-pig intraperitoneally injected. From the cultures the same results ensued, and the guinea-pig did not die.

Plate cultivations on agar were then made, and then transferences to pepton-water, with which a guinea-pig was injected. The animal died, and the pepton cultures now gave the nitroso-indol reaction.

**Cholera Vibrio of the Epidemic in Holland.†**—From a series of observations made during the epidemic of cholera in Holland in 1892-3, Prof. C. H. H. Spronck concludes that the vibrios isolated from the Dutch waters are identical with the original type discovered by Koch in India. During this epidemic it was noticed that the vibrios underwent spontaneous variation, and that the virulence of organisms even recently isolated from cholera dejecta was variable. Cultures kept in the laboratory became quite unstable. The vibrios which had been found in Dutch waters during the epidemic disappeared with its cessation.

Many attempts were made to obtain a phosphorescent vibrio cultivation, but none were successful.

**Coarse and Fine Spirilla in Gut of Pig.‡**—Dr. Th. Smith recalls an observation made by him in 1889, which is of interest in respect of recent finds of fine spirilla in cholera dejecta. He then found non-liquefying comma bacilli in the large intestine of swine. Preparations stained with alkaline methylen-blue showed, besides vibrios, numerous

\* Centralbl. f. Bakteriol. u. Parasitenk., xvi. (1894) pp. 325-6.

† Verhandel. Kon. Akad. Wetensch. Amsterdam, 2<sup>te</sup> Sec., Dcel iii. No. 12.

‡ Centralbl. f. Bakteriol. u. Parasitenk., xvi. (1894) p. 324.

fine spirilla consisting of two or three turns, and the length of these was about  $2 \mu$ . The author possesses one preparation over five years old, which still shows delicate spirilla quite clearly. These appearances were never seen in cultivation.

**Mechanism of the Virulence of *Staphylococcus pyogenes aureus*.\***

—Dr. H. Van der Velde records the results of a comparative study between an attenuated and virulent variety of *Staphylococcus pyogenes aureus* made on dogs and rabbits.

From the experiments on rabbits, it was found that the virulence of *Staphylococcus* could be augmented by repeated passages through this animal, and that when attenuated and virulent cocci were injected into the pleural sac, the former lost and the latter gained in virulence. The attenuated cocci are more easily acted upon by the body juices, and by the leucocytes, than the virulent cocci, which secrete a special substance. This, which causes the death of the leucocytes, is termed "substance leucocide" or *leucocidine*. It is destroyed by heating for ten minutes to  $58^{\circ}$ .

Leucocidine is formed in artificial cultivations (bouillon) as well as in natural (blood-serum) without and within the body, and in equal quantity by virulent and non-virulent cocci.

Besides leucocidine, the attenuated and virulent cocci secrete "lysines," which neutralize the bactericidal substance of the juices. Neither leucocidine nor lysine can be considered as special attributes of the virulent variety, they merely assist the infection. Virulence is to be considered as a greater or less tolerance on the part of cocci to the bactericidal substance of the juices. Increase of bactericidal power of the liquid part of the exudation probably depends on the white corpuscles.

With regard to dogs, the author found that both attenuated and virulent cocci were equally destroyed by the blood and serum, and that this animal reacted with the same intensity to both varieties. Repeated passages of cocci failed to increase the virulence.

**Manuals of Bacteriology.**—Dr. L. Heim's Text-book of Bacteriology† is a volume of 528 pages, illustrated by 138 plates and 50 photographs. The work is divided into three parts, the first of which deals with bacteriological research in general, and the necessary apparatus and requisites. The second part treats of the biological and morphological characters of Bacteria, and the third is devoted to bacteriological diagnosis.

Dr. Bordoni-Uffreduzzi's Manual of Bacteriological Technique‡ has recently reached its second edition, which is about twice the size of the first. Several new chapters, numerous figures, and eight chromolithographic plates have been added, while a special feature is a section dealing with the malaria parasite.

\* La Cellule, x. (1894) pp. 401-60 (1 pl.).

† Stuttgart, 1894.

‡ Mailand, 1894. See Centralbl. f. Bakteriol. u. Parasitenk., xvi. (1894) pp. 384-8.

- AUCHÉ, A.—Sur le cocco-bacille rouge de la sardine. (On the red *Cocco-bacillus* of the Sardine.) *Compt. Rend. Soc. de Biol.*, 1894, pp. 18–21.
- COHN, F.—Ueber thermogene Bakterien. (On Thermogenous Bacteria.) *Verh. Ges. Dtsch. Naturf. u. Aerzte*, 1894, Teil 2, Hälfte 1, pp. 148–51.
- GALIPPE—Note sur la présence de microbes dans les conduits excréteurs des glandes salivaires normales. (Note on the presence of Microbes in the Excretory Ducts of Normal Salivary Glands.) *Compt. Rend. Soc. de Biol.*, 1894, p. 100.
- GRIMBERT—Recherche du bacille d'Eberth dans l'eau. (Studies on the Bacillus of Eberth in Water.) *Op. cit.*, p. 399.
- HEIM, L.—Ueber *Streptococcus longus pyothorakos*. *Münch. Med. Wchschr.*, 1894, pp. 429–31.
- HELME, F., & RANGÉ, P.—Classification des Microbes. (Classification of Microbes.) *Semaine Méd.*, 1894, pp. 279–83.
- HERRNHEISSER, J.—Untersuchungen über den Nährwert des sterilisierten Glaskörpers für einige pathogene Bakterienarten. (Investigations on the Nutrient Value of Sterilised Vitreous Body for some Pathogenous Species of Bacteria.) *Prag. Med. Wchschr.*, 1894, pp. 269–70, 297–8.
- MAFFUCCI—Ricerche sperimentali sui prodotti tossici del bacillo tubercolare. (Experimental Researches on the Toxic Products of the Bacillus of Tuberculosis.) *Sperimentale*, 1894, pp. 285–7.
- PFUHL—Ueber das Vorkommen des *Vibrio Metschnikovi* (Gamaleia) in einem öffentlichen Wasserlauf. (On the presence of *V. Metschnikovi* in an open water-course.) *Zeitschr. f. Hygiene*, XVII. (1894) pp. 234–7.
- SCHRAKAMP—Über die Strategie des tierischen Organismus gegenüber den Bacillen. (On the Defensive Powers of the Animal Organism against Bacilli.) *Verh. Ges. Dtsch. Naturf. u. Aerzte*, 1894, Teil 2, Hälfte 2, pp. 13–14.
- URY, J.—Ueber die Schwankungen des *Bacterium coli commune* in morphologischer und kultureller Beziehung. Untersuchungen über seine Identität mit dem *Diplobacillus pneumoniae* Friedlaender u. mit dem *Bacillus* des Abdominaltyphus. (On the Morphological and Cultural Variations of *B. coli commune*. Investigations on its Identity with *D. pneumoniae* and with the Bacillus of Abdominal Typhus.) *Arch. f. Exper. Pathol. u. Pharmacol.*, XXXIII. (1894) pp. 464–5.
- ZOFF, W.—Ueber niedere tierische und pflanzliche Organismen, welche als Krankheitserreger in Algen, Pilzen, niederen Tieren und höheren Pflanzen auftreten. (On low Animal and Vegetable Organisms which appear as producers of disease in Algæ, Fungi, lower Animals and higher Plants.) Erste Mitteilung. *Beitr. z. Physiol. u. Morphol. niederer Organismen*, hrsg. v. W. Zopf, Heft 4, pp. 43–68.



## MICROSCOPY.

## a. Instruments, Accessories, &amp;c.\*

## (1) Stands.

Messrs. Ross & Co.'s "Eclipse" Bacteriological Microscope.—In its main features this stand is similar to that described on p. 507 of the

FIG. 81.

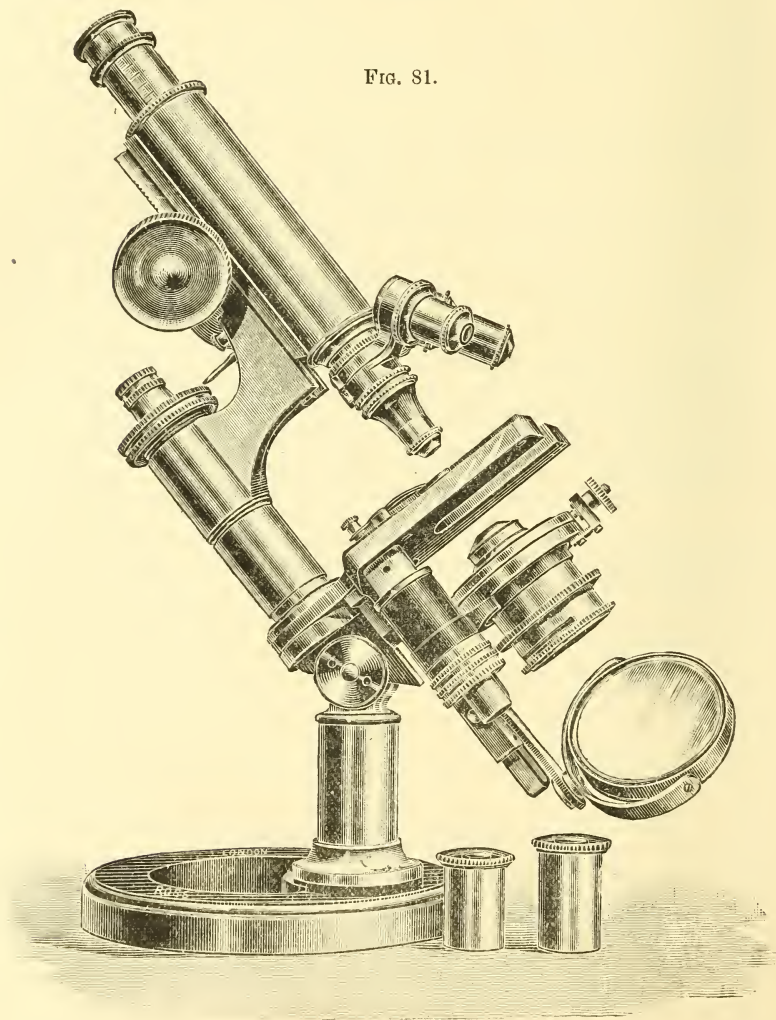

\* This subdivision contains (1) Stands; (2) Eye-pieces and Objectives; (3) Illuminating and other Apparatus; (4) Photomicrography; (5) Microscopical Optics and Manipulation; (6) Miscellaneous.



August number of this Journal. In the present form (fig. 81) the draw-tube is graduated in millimetres and the stage has been replaced by one

FIG. 82.

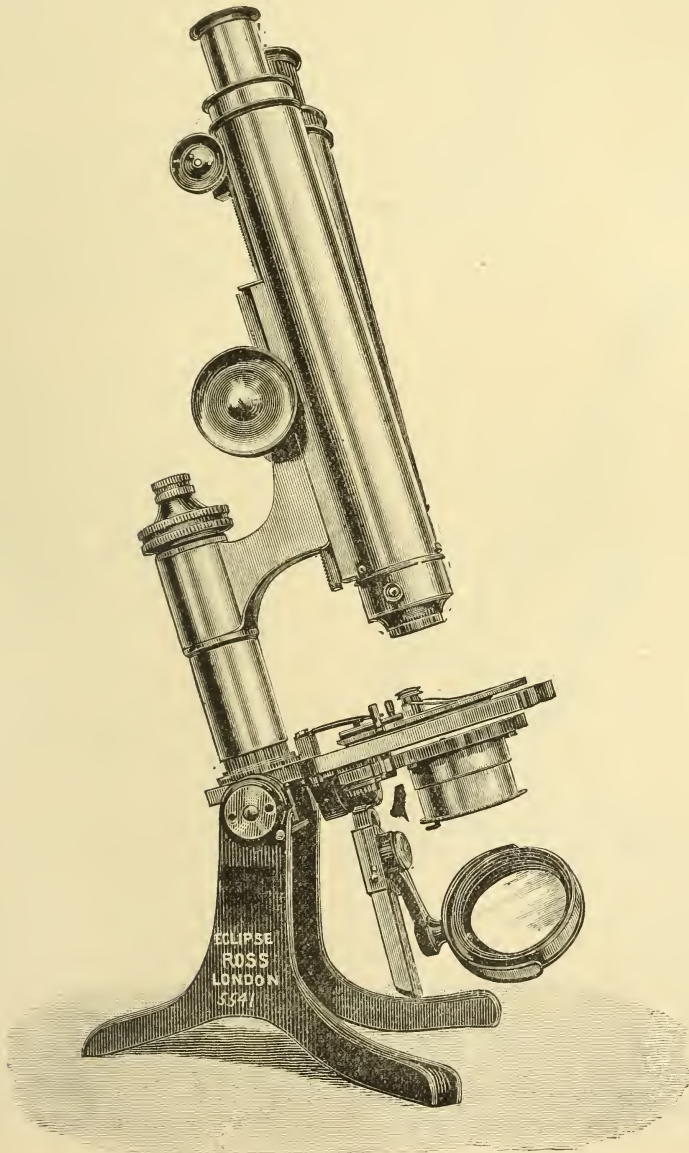

of horse-shoe form. The sub-stage, which has centering-screws, is carried on a bar pivoted to the stage-plate; the coarse-adjustment is effected by a spiral movement in the body of the sub-stage, and the fine-adjustment is by a micrometer-screw actuated by a milled head at the bottom of the bar; the condenser supplied is an Abbe achromatic of either N.A. 1.40 or N.A. 1.20. The sub-stage is attached to the side of the stage, and can be turned in or out of position as desired. The triple nose-piece on this stand is so adapted that the objectives focus in the same plane. The slotted tail-piece carrying the mirror can be swung round to allow of the mirror being used for super-stage illumination.

**Messrs. Ross & Co.'s "Eclipse" Binocular Microscope.**—This stand (fig. 82) differs from the other examples of the "Eclipse" class in having a "bent claw" foot instead of a circular ring. The sub-stage apparatus is attached to the under side of the stage-plate, and can be turned in or

FIG. 83.

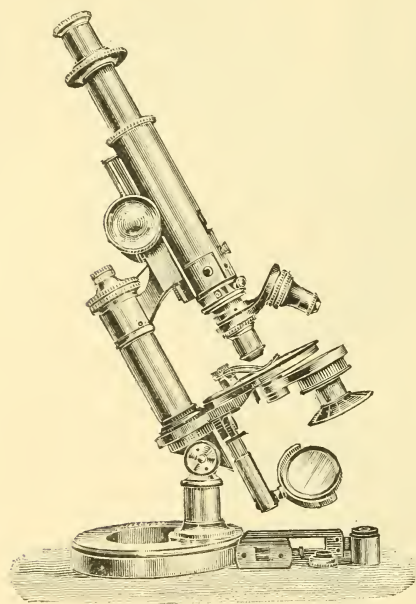

out of position as desired. The adjustments and the method of fixing the mirror are the same as in the preceding stand.

**Messrs. Ross & Co.'s "Eclipse" Petrological Microscope.**—A description of this Microscope (fig. 83) appears on p. 509 of the August number of this Journal.

**Support for the Microscope.\***—Mr. R. B. Coutant has devised a support intended for the use of large or small Microscopes in either an upright or inclined position. It consists of two triangular wooden boxes, one sliding in the other. When closed, the height of the boxes is  $29\frac{1}{2}$  in., but the movable one can be drawn out and fixed in any position so as to increase the height up to 10 in. more. The inner box has a double top,

between the layers of which a lamp-carrier swings horizontally through an arc of  $90^\circ$ . The upper and lower layers are each made up of three triangular pieces of wood (fig. 84) with the grain parallel with the outer edge so as to prevent warping. Three pieces of wood (the unshaded parts of fig. 85) serve to keep the layers apart. The lamp-carrier, as shown in fig. 85, has a slot in which a screw passing through the top of the support engages so as to fix it in any position. The projecting end of the carrier has a slot, in which the upright rod of the lamp fits, as seen in fig. 86. The outer box is  $18\frac{1}{2}$  in. high. In the

\* English Mechanic, ix. (1894) pp. 108-9.

right-hand panel, 5 in. from the top, is fixed a large set-screw, which works through a slot in the corresponding side of the inner box into a

FIG. 84.

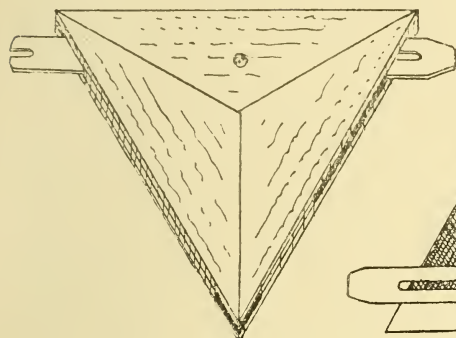

FIG. 85.

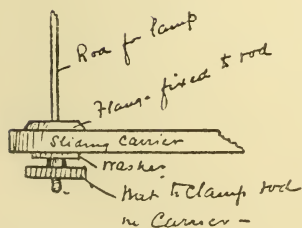
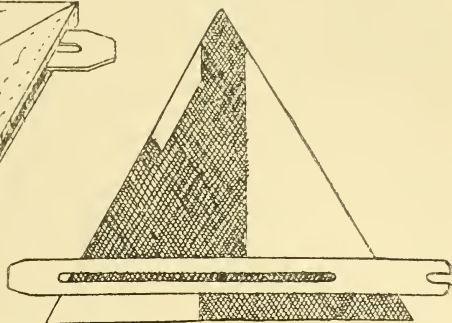

FIG. 86.

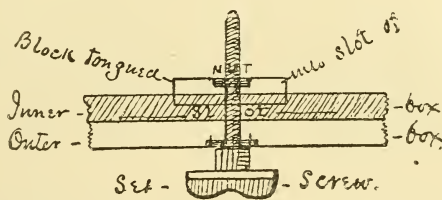

FIG. 87.

nut (fig. 87), so that when the screw is released the inner box may be raised or lowered, and when tightened the two boxes are securely clamped together and fixed at any elevation.

(2) Eye-pieces and Objectives.

**New 1/5 Objective.\***—Mr. J. Michels states that he possesses a 1/5 objective of 50° air angle which was constructed for him by Spencer and Smith, of Buffalo. The lens has fine definition and is specially adapted for work with covers 1/10 in. thick. The writer thinks that a lens of this sort, one that can be used in conjunction with a compressor having a screw-adjustment at each end, and with a cover-glass 1/10 in. thick, will be found very useful to those making biological researches.

**Koristka Semi-Apochromatic 1/15 Objective.†**—Herr J. Amann gives the results of the tests which he has applied to this objective. According to the catalogue of the firm, the composition of the system is similar to that of the apochromatic, except that the fluor-spar is replaced

\* Amer. Mon. Micr. Journ., xv. (1894) pp. 156-7.

† Zeitschr. f. wiss. Micr., xi. (1894) pp. 145-8.

by a suitable glass. The aperture is said to be 1.30. The objective is to be used with compensation eye-pieces, and for the tube-length of 160 mm. should give magnifications respectively of 600, 900, 1200, 1800, 2700 with the eye-pieces 4, 6, 8, 12 and 18.

As the result of his examination of the system, the author determines the focal length as 1.8 mm., and the numerical aperture measured with the apertometer as 1.32.

When used as eye-piece with the front lens turned towards the eye, the system shows no large spots and not too many small ones.

The objective stood the Abbe test very well. With central illumination, when an immersion condenser of 1.40 N.A., and the compensation eye-piece 6 were used, the edges of the slit of the test-plate in the central parts of the field of view were very sharp and perfectly free from colour-fringes and mistiness, while on the periphery small colour-fringes were visible, and, quite on the edge, a slight mistiness. With the slightest changes in the adjustment the colour-fringes of the secondary spectrum make their appearance. The image is sharp and free from colour up to the extreme edge of the field. With the compensation eye-piece 12, the edge of the eye-piece diaphragm has a light orange-yellow fringe.

With oblique illumination including rays inclined  $60^\circ$  to the axis, the colour-fringes of the secondary spectrum are very distinct, but no mistiness is observed. By blocking out the most oblique rays and diminishing the effective aperture to about 1.20, the colour-fringes are reduced to a minimum, and the two edges of the slit appear very sharply defined up to the extreme edge of the field. A test of the objective by means of a scale of *Pleurosigma* and also of tubercle-bacilli gave very good results.

The resolving power corresponds perfectly to the aperture 1.32. With central illumination the cross-striations of *Surirella gemma* are very distinct. With intense lamp-light and oblique illumination the objective showed the cross-striation of *Amphipleura pellucida*. With oblique monochromatic illumination by means of sunlight and a  $CS_2$ -prism these striations appear in the limit between the green and blue ( $\lambda = 0.48 \mu$ ) of the spectrum; in blue light ( $\lambda = 0.45 \mu$ ) they are very distinct, and in the blue-violet ( $\lambda = 0.42 \mu$ ) indications of the pearl-structure are visible. In order to test the optic homogeneity and elasticity relations of the material of the lenses, the behaviour of the objective in polarized light was examined. The lenses were found to be perfectly homogeneous and isotropic, for no signs of double-refraction were noted either with parallel or with convergent polarized light.

### (3) Illuminating and other Apparatus.

**Clay Wick for Microscope Lamps.\***—The indestructible clay wicks give 25 per cent. more light than cotton wick. They are made in any desired shape or size and have been used for high-power work in some laboratories for months. They require no trimming or attention and the wicks do not clog. These wicks are made by arranging vegetable fibres in the unbaked clay, so that when fired a series of longitudinal pores are left through which the oil is raised by capillary attraction. Owing to

\* Amer. Mon. Micr. Journ., xv. (1894) pp. 30-1.



the perfect combustion, the flame is perfectly white, smokeless, and devoid of odour.

**Magnifier for Reading Small Print.\***—This magnifier, which is now being offered for sale in the shops of Parisian opticians, consists, not of an ordinary lens, but of a thin-walled glass-tube filled with water and closed at both ends. This tube, which is in length about that of the lines of a book, is held at both ends in a piece of bent wire which is provided in the middle with a handle so that the instrument can be rolled over the lines of the print.

**The New Photometry.†**—Prof. Crova is the inventor of new and improved methods of photometric work. The use of the electric light has been the means of exposing the many imperfections of the old photometric processes. The standard sources of light, as candles, Carcel lamp, Hefner-Alteneck lamp, &c., have all great faults, and the various photometric apparatus are so imperfect that the simple law of the square of the distances in practice becomes a source of error.

Prof. Crova finds that the Carcel lamp is the most reliable of all known standard sources of light, if the instructions of Dumas and Regnault for its use are rigorously followed. When, however, the Carcel lamp is used for measuring the intensity of an arc or incandescent light, it loses a great part of its value owing to the fact that the illuminated surfaces of the screen of the photometer have no longer the same colour. In the laboratory this difficulty might be overcome by isolating with the spectrophotometer the rays of 582 wave-lengths, and from the ratio of their respective intensities determining the total intensities of the two sources of light. Such a method requires expensive instruments and special knowledge.

Prof. Crova therefore recommends a simple means for obviating the difficulty, which consists in observing the screen through a glass vessel with parallel walls filled with a solution of nickel and ferric chlorides. The proportion of the two salts is so chosen that the solution only transmits rays which have a wave-length of 582.

The whiteness of the different sources of light, Crova defines as follows:—It is the ratio of the intensities of the rays whose wave-lengths are about 582  $\mu$  and 650  $\mu$ . The intensity for the latter wave-length is obtained by observing the screen through a glass coloured red with cuprous oxide. Experiment has shown that this ratio is unity for sources of light of the same colour as the Carcel lamp, that it varies from 1.05–1.23 with the electric incandescent light, and from 1.5 to 1.7 with the arc-light.

In photometric work the great differences of intensity of the sources of light offer a serious difficulty, since for direct working, a room 20–30 m. long would be necessary. This difficulty is overcome by placing the intense source of light in a small side room, separated from the photometric room by a wall in which is an opening covered with a ground glass. This glass is covered with a screen in which is a hole of exactly a square centimetre, and the source of light is exactly a metre from the glass. The square centimetre of the ground glass gives in the photometric room a light whose intensity is a certain fraction easily

\* Central-Ztg. f. Optik u. Mechanik, xv. (1894) p. 189. † *Tom. cit.*, pp. 194–5.

determined of the incident light. Glasses can thus be graduated and named, e. g. a ground glass of 100 Carcels is one which, brought into a field of this intensity, transmits an amount of light exactly equal to one Carcel at the unit of distance.

In making a photometric determination by comparison with a Carcel lamp, instead of the distances being changed, the aperture in the screen is made variable and its size can be measured by a micrometer screw.

**Colorimeter with Lummer-Brodhun Prism Pair.\***—Dr. H. Krüss points out the advantages of the use of four prisms in the colorimeter

FIG. 88.

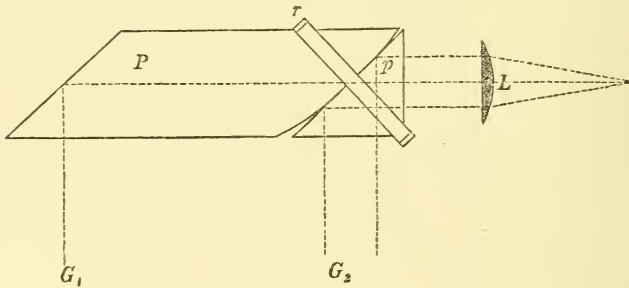
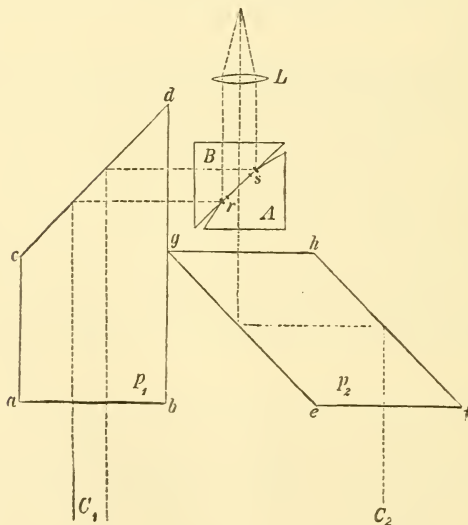

FIG. 89.



devised by himself over the arrangement of only two prisms which has been more recently proposed by Dr. C. Pulfrich.

\* Zeitschr. f. Instrumentenk., xiv. (1894) pp. 283-5.

The arrangement of Pulfrich is shown in fig. 88, that of the author in fig. 89.

Against the arrangement in fig. 88, the author raises the objection that the rays coming from the liquid  $G_1$  have a much longer path to travel through the prism  $P$  than those from the liquid  $G_2$ , which only pass through the reflecting prism  $p$ . This difference of path amounts to 4 cm. if the distance between the centres of the liquid columns  $G_1$  and  $G_2$  is 5 cm.

The advantage, on the other hand, of the author's arrangement, which at first sight appears so unsymmetrical, is that it is really optically perfectly symmetrical, since the lengths of path of the rays in the prisms  $P_1$  and  $P_2$  are the same, and the number of reflections is the same.

Photometric experiments made by the author on Jena flint glass (No. 36) showed that the coefficient of absorption for 1 cm. thickness was 0.982, and for 4 cm. 0.930. Thus if this glass were used in the Pulfrich colorimeter with the centres of the two glass vessels 5 cm. apart, there would be an error of about 7 per cent. owing to the strong absorption in the prism  $P$ .

The absorption also varies throughout the spectrum; there is a considerable increase in the loss of light from the red to the violet end. In the Pulfrich arrangement, therefore, for different coloured solutions a different factor of correction would be necessary. The author suggests that the equality of path of the rays coming from the two liquids might be easily effected in the Pulfrich arrangement by increasing the length of the prism  $p$  downwards.

#### (4) Photomicrography.

Photomicrograms of Ice and Snow Crystals.\* — Herr Neuhaus describes the method adopted by Redner for taking photomicrograms of ice and snow crystals. The apparatus was set up out of doors. The source of light was a small petroleum lamp and the objective a projection-system of 31 mm. focal length (Hartnack). The linear magnification varied between twelve and twenty times. A concentrated alum solution, kept from freezing by the addition of rock-salt, served to absorb the heat-rays. Altogether twenty pictures were taken at  $-5$  to  $-10^\circ$  R., five of ice and the other fifteen of snow crystals. Single pictures showed up to ten different forms of crystals.

The Optics of Photography.†—This second part of Dr. Vogel's handbook runs to 367 pages and has numerous figures with a coloured frontispiece illustrating the Vogel-Kurtz process of printing in three superposed colours. The subjects of photographic optics, viz. the methods of forming images, faults of lenses, intensity of illumination, &c., is dealt with in seven chapters forming an appendix to the work. The main portion of the book, consisting of 31 chapters extending over 266 pages, treats of such subjects as:—Intensity of light and Lambert's law, photometry, standards of light, Methe and Michalke's law of photographic reciprocity in developed films, sources of artificial light for photography,

\* SB. Gesell. Naturforsch. Freunde, 1893, pp. 18–9.

† 'Handbuch der Photographie, II. Theil: Das Licht im Dienste der Photographie und die neuesten Fortschritte der Photographischen Optik,' by Prof. Dr. H. W. Vogel, Berlin, 1894. See Nature, l. (1894) pp. 589–91.

properties of optical sensitizers, colour screens, spectrographs, direct photography in natural colours, &c. As regards standards of light, the author gives the preference to the amyl-acetate lamp of Hefner-Alteneck. The so-called law of photographic reciprocity is very fully discussed. The greater portion of the book, however, is devoted to the action of special sensitizers and kindred subjects.

(5) Microscopical Optics and Manipulation.

**Experiments with a Right-angled Prism.\***—Herr W. G. Röntgen finds that a right-angled prism may be used in order to demonstrate the fact, originally discovered by Helmholtz, that the line of sight of the eye does not coincide with the axis of the eye.

On looking with one eye through the hypotenuse face of a right-angled prism with vertical prism edge, an image of the head is seen which, unlike that from a mirror, is congruent with the object. The author discovered that for any position of the head the line of sight of the image from the back prism edge to the pupil in the image always passed through the same part, but not through the middle of the pupil; it was always directed to a point from the middle towards the side of the nose.

Further experiments were made by the author with a right-angled prism by mounting it on a goniometer with the prism edge parallel to the axis of the instrument. When the telescope is directed upon the hypotenuse face a sharp image of the cross-wires is seen which only coincide with the cross-wires seen directly if the vertical cross wire and the prism edge lie in one plane. By rotating the prism the image of the cross-wires does not change its position in the least. These observations may be made use of in order to set the vertical cross-wire parallel to the axis of rotation of the instrument, and also to determine whether the prism is exactly right-angled or not. In the latter case, instead of one image only of the vertical cross-wire, two are seen which lie so much farther to the right and left of the wire seen directly, the greater the error of the prism. Since all these experiments succeed equally well with mirrors set at right-angles, this observation affords a simple means of adjusting two mirrors exactly at right-angles to one another.

When the vertical cross-wire was rotated through a certain angle the image was turned through the same angle, only in the opposite direction. When, therefore, the vertical cross-wire was turned through an angle  $\alpha$ , a rotation of the prism about an incident ray as axis through the angle  $\frac{\alpha}{2}$  in the same direction brought the image into its original position again.

(6) Miscellaneous.

The late Mr. G. E. Blenkins, F.R.C.S.—As announced at the October meeting of the Society, we have lost one of our oldest and most honoured Fellows by the death of this gentleman. He joined the Society in 1848, and was active in its service, being Secretary from 1858-67. We learn some details from the *British Medical Journal*.†

\* *SB. Physikal-medicin. Gesell. Würzburg*, 1894, pp. 53-6.

† *Brit. Med. Journ.*, No. 1762, 1894, p. 789.



He was a Deputy Inspector-General. "He entered the Grenadier Guards in April 1838, and served in the Crimean campaign, receiving the gold medal with clasp, the fifth class of Medjidie, and the Turkish medal. After serving more than thirty years in the regiment he retired in December 1868. Mr. Blenkins has so long retired from active work that the younger generation will hardly recognize his name as one of the most active and valued workers in the metropolis some thirty years ago. He was one of that distinguished class of army surgeons, then by no means too numerous, who to a thorough knowledge of his profession and departmental duties, added a great love of scientific research in the active study of its most difficult departments. He was a practical and skilful histologist, when to be so was a rare distinction in the schools in civil life.

"We incline to believe that he was the first amongst the teachers of histology in the metropolitan medical schools who instituted classes of practical microscopic work and demonstration. He lectured and taught at Lane's School of Anatomy and Medicine adjoining St. George's Hospital, and as far back as 1851 he carried on a class of practical histology, in which every student was provided with a Microscope, and was taught himself to make, prepare, and put up the specimens. This class Mr. Blenkins conducted while a surgeon in the Guards, and it had, at that time at least, few if any parallels in this country, for what is now an every-day rule of teaching was then a rare and brilliant exception."

The writer of the notice adds:—"This brief tribute is due to the memory of one of the most lovable and accomplished surgeons of his day, for to a handsome presence, great dignity and refinement of manners, of which the only fault perhaps was a somewhat marked reserve, Mr. Blenkins joined singular modesty, unfailing kindness of heart, and an interest in the personal welfare of his pupils, which lasted throughout his and their lives."

To the Society's Transactions he contributed in 1858 a note "On an early Human Ovum."\*

The late Mr. F. R. Cheshire.—We regret to learn that Mr. F. R. Cheshire, who was some years a Fellow of this Society, died on the 17th of September last, aged 61. Mr. Cheshire was greatly interested in Bees, and in 1885 he made us two interesting communications, which will be found in the Journal for that year. One was by himself on "The Apparatus for Differentiating the Sexes in Bees and Wasps," the other, in conjunction with Mr. W. Watson Cheyne, dealt with "The Pathogenic History and History under Cultivation of a new Bacillus (*B. alvei*), the Cause of a Disease of the Hive Bees hitherto known as Foul Brood."

Removal of Rust from Instruments.†—Herr Säuger recommends the following method for removing rust from instruments:—The instruments are placed for the night in a saturated solution of chloride of tin, when the layer of rust will disappear by reduction. After taking them out of the solution, the instruments are washed with water, brought

\* Cf. Trans. Micr. Soc., vi. (1858), pp. 5-9, pl. ii.

† Central-Ztg. f. Optik u. Mechanik, xv. (1894) pp. 237-8.

into a hot solution of soda-soap, and then dried. A further cleaning with absolute alcohol and whiting is also advisable. Ordinary petroleum may also be used with advantage for removing rust. Paraffin oil is recommended as the best means of protecting steel instruments from rust. To avoid using excess of oil, the best method of procedure is to take a solution of 1 part paraffin oil in 200 parts benzine, to immerse the instruments in this solution, and afterwards place them on a plate in a dry room where the benzine may evaporate.

### B. Technique.\*

#### (1) Collecting Objects, including Culture Processes.

**Aseptic Protozoa Cultures.**†—Dr. C. O. Miller says that in the preparation of Protozoa cultures it is necessary to be extremely careful to prevent contamination of the media, and greater precautions are required for liquid than for solid media. For direct examination of the appearances occurring in the cultures he used sterilized moist chambers, hanging drops, Petri's capsules and ordinary tumblers. The most trustworthy cultures were made in Erlenmeyer's flasks holding 100–200 ccm. Discontinuous sterilization was usually employed, the media being steam sterilized for 15 minutes on three successive days. For some experiments an autoclave was used for 15 minutes at a pressure of two atmospheres. Inoculations or transplantations may be made with a platinum loop, but it is better to use a pipette. A couple of dozen pipettes (from 18–20 cm. long) may be sterilized together. The author adds many cautions and precautions too minute to give in full, but these may be easily apprehended. The infusions used were neutralized bouillon 2–4 parts to 100 of water; 1/2 per cent. glycerin in which is placed a little bit of tendon 1 mm. square; linseed decoction diluted down to the colour of white wine; dilute hay infusion with 1/2 per cent. grape sugar or 1/5 per cent. milk. These dilute solutions give better results than thicker ones. After filtration, 1–1½ ccm. were placed in the glass vessels. One of the greatest difficulties in these cultivations is the presence of fungi, though most of these are got rid of at a temperature of 37·0°, which is unsuitable to them and favourable to Amœbæ, Plasmodia, and many other Protozoa.

**Apparatus for Pure Cultivation of Algæ.**‡—Herr P. Kossowitsch adopted the following arrangement for the pure cultivation of Algæ. On the bottom of an Erlenmeyer's flask (fig. 90) having a diameter of 15·5 ccm. is placed a thin layer of sand. The neck of the flask is plugged with a triply perforated caoutchouc stopper. Through one of the holes passes the glass tube *d*, which reaches nearly to the bottom of the flask.

\* This subdivision contains (1) Collecting Objects, including Culture Processes; (2) Preparing Objects; (3) Cutting, including Imbedding and Microtomes; (4) Staining and Injecting; (5) Mounting, including slides, preservative fluids, &c.; (6) Miscellaneous.

† Centralbl. f. Bakteriol. u. Parasitenk., xvi. (1894) pp. 273–80.

‡ Botanische Zeitung, Jahrg. 52 (1894) pp. 101–3 (2 figs.).

The outer end of the tube is connected with two U-shaped tubes *a* and *b*, joined by rubber tubing. In their course are six bulbs, and their bend holds some strong sulphuric acid for drying and sterilizing the air. Dust and other impurities are prevented from entering by means of the short tube *n*, which is filled with cotton-wool. Through the second hole in the caoutchouc plug passes the tube *c*. Through this the Algæ are introduced after the apparatus has been sterilized; this done it is closed with sealing-wax. Through the third hole passes the tube *k*. This is the exit air tube; the bottle end is narrowed, and the end of the long arm which passes into the small Erlenmeyer's flask *b* containing nutrient solution is curved. From the flask *b* passes the bulbod U-shaped tube *l*.

FIG. 90.

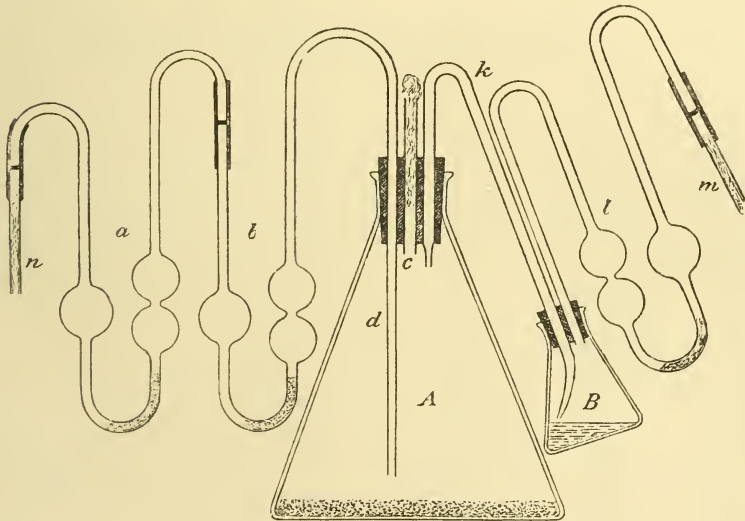

This also holds some sulphuric acid and is closed with cotton-wool at *m*. The long arm of tube *k* which unites the large and small flasks is bent away from the short arm, and is of such length that its extremity would not touch the nutrient medium if the apparatus were in the horizontal position.

The air was introduced and a current maintained by a modification of A. Koch's apparatus, which consists of a flask holding 5 litres, A, fig. 91, closed with a caoutchouc stopper with four perforations for the passage of four tubes. Water is introduced through *a*, and the air is driven out through *i*, having previously passed through *c* and the flask B filled with fluid. When the bottle A is quite full and the water run up into the siphon *d*, the bottle A is emptied in a few minutes. Then the

fluid in the bottle B runs up the tube *c*, and thus the air is prevented from escaping backwards. The bottle A is meanwhile filled with air through the tube *b*.

When the bottle A is almost empty the water in the siphon *d* falls,

Fig. 91.

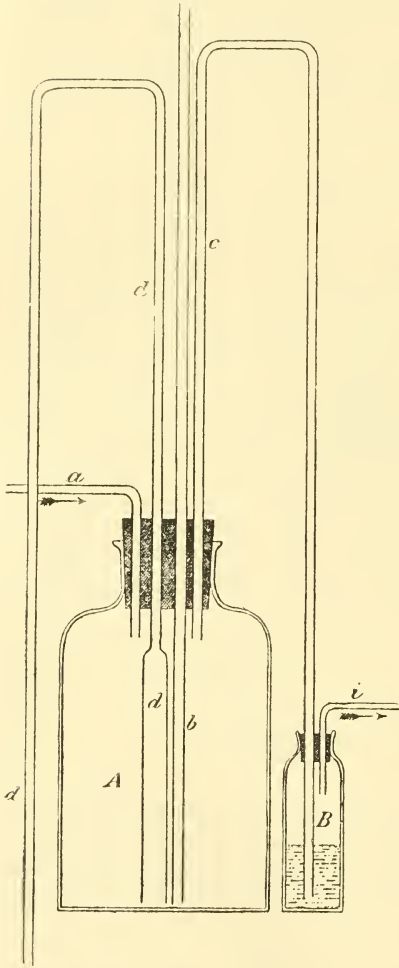

provided the lower end inside the flask be sufficiently broad, and the water flowing back without interruption again drives on the air into the cultivation vessel. There is no other outlet for the air as the siphon *d* and the tube *b* are closed by water. The amount of pressure with which the air is forced out depends on the height of the tubes *b*, *c*, *d*: the longer they are the greater the pressure.

If the water runs into the bottle A too quickly, the air pressure rises too high in the bottle, the water is forced into the siphon *d*, so that the bottle A is emptied too soon and before it has become properly filled, but if the water inflow be regulated the apparatus will be found to work with great regularity.

**Cultivation Capsule for Fungi.\***—Dr. J. H. Wakker describes an apparatus which he has devised for cultivating fungi in the tropics, where it is necessary to use agar as the nutrient medium. It is a simple glass capsule in the middle of the top of which is an opening *o*, with the funnel-shaped piece *h* above (fig. 92). The free edge of the funnel has a thick lip *r*. The top *a a* forms a movable lid for the capsule, which can be securely closed. The funnel is

stopped with cotton-wool *w*, and protected against dust by a rubber cap *f*. When a layer of the medium has been poured in the capsule is

\* Centralbl. f. Bakteriol. n. Parasitenk., xvi. (1894) pp. 348-9 (2 figs.).



sterilized, and several may be sterilized at once by placing them in a tin box with a number of shelves (fig. 93).

FIG. 92.

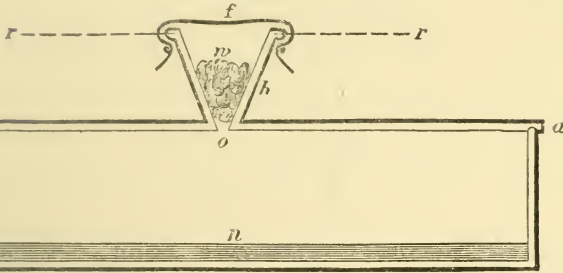
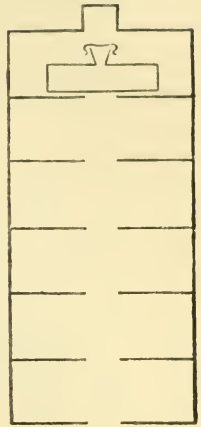

FIG. 93.



**Air Filter.\***—Herr J. J. van Hest describes at considerable length a simple apparatus which he has devised for filtering air and thus freeing it from bacteria, fungi, &c. The principle of the filter depends on the fact that these organisms are not devoid of weight, and hence if a current

FIG. 94.

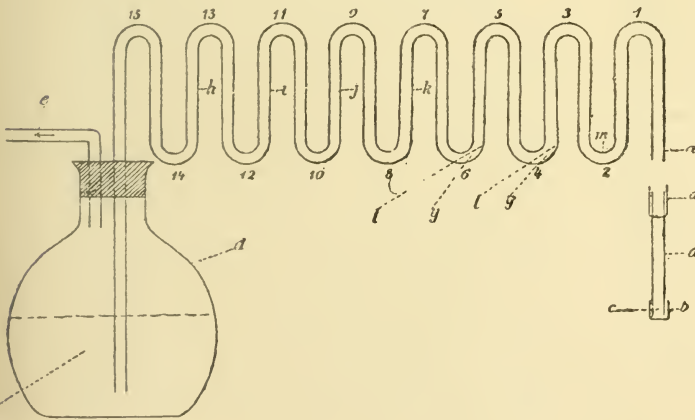
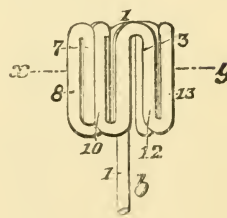

FIG. 95.



of air be passed through a fine tube with a perfectly smooth interior and numerous coils or turns in its circuit, organisms will be deposited inside. The rapidity with which the air may be driven through is 1.5-2 m.

\* Centralbl. f. Bakteriell. u. Parasitenk., xvi. (1894) pp. 435-47, 495-99 (11 figs.).

per second or 1 litre per minute. The tubes, which are made of tin or are tin-lined, are 3-6 mm. thick, with a bore of 1-4 mm. in diameter. To the filter there are fifteen turns up and down, each of them 2 cm. long.

The filter may be used either extended as in fig. 94 or in the more compact form seen in fig. 95.

Fig. 96.

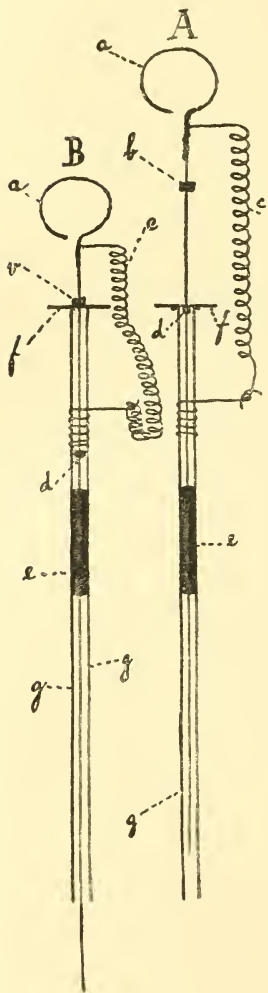

**Infection Needle.\***—Mr. J. C. Bay describes a needle used by him in the study of the lower cryptogams. The needle itself, made of brass or copper wire, passes through the centre of a metal disc *f*, and its lower part is surrounded by a glass tube *g* (fig. 96). The disc can move between two stoppers *b* and *d*. The upper end of the needle is bent round to form a grip *a*, while just below this is the spring *c*, the other end of which is attached to the glass tube *g*. Inside the tube is a cotton stopper *e*. When used, the upper part of the glass tube is charged with cotton, and this outside wrapper should be of the same size as the opening of the flasks, so that when the plug of the flask is removed for inoculation, the needle case exactly fills the neck. Fig. A shows the needle guarded, fig. B when pressed down for removing a sample from a culture.

**Setting Cultivations on Solid Media.†**—Dr. P. Miquel fixes all kinds of cultivations by exposing them to the vapour of trioxymethylen. In the dry condition this substance gives off but little methylic aldehyde, to which its fixative property is due. It must therefore be moistened with water, or better, dissolved in a saturated solution of calcium chloride. It is only necessary to put the substance and the cultures under a bell-jar for twenty-four hours to about three days. The media are quite unaffected, the growths are all killed, and it is only necessary to hermetically seal up the culture vessel to prevent evaporation. The appearance of the cultures is unaltered as a rule, though occasionally chromogenic bacteria and some moulds lose a little colour.

**Parasitic Cell-inclusions and their Cultivation.‡**—Dr. O. Busse has successfully inoculated cell-inclusions on animals, in which they have multiplied; has obtained pure cultivations on various nutrient

\* Amer. Mon. Micr. Journ., xv. (1894) pp. 44-5 (2 figs).

† Ann. de Micrographie, vi. (1894) pp. 422-3.

‡ Centralbl. f. Bakteriol. u. Parasitenk., xvi. (1894) pp. 175-80 (4 figs.).

media, and has successfully reinoculated these latter on animals. The material was obtained from a chronic inflammatory growth of the tibia, the alternative diagnosis being softened sarcoma. From teased out fresh material were obtained bright circular or oval bodies, varying in size from a nucleus to a liver cell, lying within, and also without giant cells. The bodies have a distinct double contour and frequently contain one or more corpuscles. Sometimes appearances were seen recalling a capsule. This capsule remained unstained when cover-glass preparations were treated with methylen-blue, carbol fuchsin, logwood, or by Gram's method, though the inner doubly contoured portions were strongly coloured. The only successful method of preparation was to treat with caustic soda and examine in water. The material was inoculated on three animals (dogs and rabbits) and with most successful results, it being noted in one case at least, that the parasite was present in the lymphatic glands. Pure cultivations on agar, glycerin-agar, gelatin, blood-serum, potato-gelatin, and potato were obtained. On gelatin and agar the growth is white, and the gelatin is not liquefied. Potato was the best medium, the growth at first being dirty white, changing afterwards to a grey brown. The cultivation appearances differ somewhat from the original; the double contour being for the most part absent.

When reinoculated on animals, there was reversion to the original type. The author showed the specimens and preparations to Prof. Loeffler who decided that the parasite was a pathogenic yeast. In favour of this view are the growth on plum decoction and the development of carbonic acid in grape-sugar bouillon.

**Cultivating Gonococcus.**—Dr. Král\* has obtained with the three following media for cultivating gonococcus very good results:—(1) 20 grm. of agar, after soaking for 24 hours, are placed in a steamer and dissolved at a temperature of 100° C. in 650 ccm. of bouillon made without salt. After cooling down to 55° C., 5 grm. of saccharose, 2·5 grm. of salt, and 350 ccm. of blood-serum are added; it is then steamed again for half an hour at 100°. The coagulated portions are removed, and the clear fluid transferred to test-tubes after filtration. (2) 2 per cent. agar, which has been cleared with the white of one hen's egg per litre, and after cooling down to 55°, is mixed with half its volume of blood-serum, and then treated as in No. 1. (3) This formula contains the further addition of 5 per cent. glycerin and 1 per cent. saccharose, which are mixed in at the same time as the blood-serum. One or two loopfuls of the pus are placed in 4 ccm. bouillon, and after shaking 2 loopfuls are distributed over the surface of the medium.

Drs. Ghon and Schlagenhauser† have used with very successful results ordinary pepton-agar smeared with human sterile blood for the isolation and continued cultivation of gonococcus. Inoculation with these blood-agar cultures on men gave positive results.

By cultivating in cattle-serum-agar the authors obtained even better results when acid phosphate of soda was added to the medium. They also tried whether an acid medium were better suited to the coccus, and found that a useful substratum was a mixture of 2 parts

\* Arch. f. Dermat. u. Syphil., xxviii. (1894) No. 1.

† Wien. Klin. Wochenschr., 1893, p. 619. See Centralbl. f. Bakteriol. u. Parasitenk., xvi. (1894) pp. 467-9.

2 per cent. agar and 1 part acid urine, either taken or made sterile. Further cultivations on this medium were difficult, but inoculations with two days old cultures of the first generation excited a suppurative urethritis in 48 hours.

**Rapid Method for making Nutrient Agar.\***—Dr. J. L. Schutz prepares agar in the following expeditious way:—1500 ccm. of water and 18 gm. of agar are boiled together in an open vessel. While boiling, 2 gm. of Liebig's meat extract are added. After boiling for half an hour, the solution is removed from the fire and cooled down to 60° C. To it are then added 10 gm. of dry pepton, 5 gm. of salt, and a hen's egg, in as much water as has been lost by evaporation. The strongly alkaline reaction is now reduced to a slightly alkaline or neutral one by the addition of HCl. The mixture is then boiled again for 5–10 minutes, after which it is filtered through a white filter paper. The filtration of a litre of this fluid does not take longer than 3–5 minutes. If the filtrate be not perfectly clear, the white of another egg must be added, and the whole reboiled until the albumen has coagulated. When the solution is transparent and thin it is easily filtered; if not, the reaction is too alkaline. To this agar, 4 per cent. glycerin may be added, so as to render it suitable for Esmarch's roll tubes.

Instead of meat extract fresh meat may be used; if so, 1/2 kilo of finely chopped meat is digested in 1500 ccm. of water for 30 minutes at 50° C.; the mass is squeezed in a linen cloth, and having been boiled for 5 minutes, the whole is filtered. To the filtrate the agar is added, and the further treatment is as before.

As the reaction is usually markedly acid, the mixture must be alkalinized or neutralized with a saturated solution of sodium carbonate.

**Nutrient Media containing Alkali Albuminates.†**—Herr Deycke recommends a medium composed of 1 per cent. veal alkali albuminate, 1 per cent. peptone, 1/2 per cent. salt, 2 per cent. agar, 5 per cent. glycerin, and 1/2 per cent. soda for cultivating the cholera vibrio, and the bacilli of anthrax, diphtheria, and tubercle. The author has found it extremely useful for the rapid diagnosis of cholera and diphtheria.

## (2) Preparing Objects.

**Preparation and Preservation of Embryos of Chelonia.‡**—Prof. K. Mitsukuri preserved nearly all his young embryos in Kleinenberg's picro-sulphuric acid; very advanced embryos were placed in the same, or in corrosive sublimate. The spot where the blastoderm was to be found was generally marked with a hair, as the thin layer of white which was necessarily left over it, coagulates in the preserving fluid, and hides it entirely from view. After three or four hours incisions at right angles were made with a sharp knife on three sides of the blastoderm. A little manipulation with forceps or scalpel easily separated the superficial coagulated white from the blastoderm beneath; the

\* Johns Hopkins Hospital Bull., iii. (1894) p. 92.

† Deutsche Med. Wochenschr., 1894, No. 25. See Centralbl. f. Bakteriol. u. Parasitenk., xvi. (1894) p. 542.

‡ Journ. Coll. Sci. Imp. Univ. Japan, vi. (1894) pp. 229–31 (1 fig.).



latter can be easily removed. After removal, the blastoderm was generally left in a relatively large quantity of the preserving fluid for some hours longer.

When the embryo was very much advanced, and the allantois had spread itself entirely beneath the shell, the removal of the shell was found to be a matter of some difficulty, as it is leathery and not brittle. The author says that he carefully scrapes the shell at one small spot with a knife until it becomes quite thin; picrosulphuric acid is applied to the spot, which is again scraped, and acid again applied. This process must be repeated, with great care, until enough of the shell is worn off to expose a very small patch of the allantoic surface. However small the opening may be, the acid is able to penetrate and harden the tissues for some space around it. The opening may then be with safety gradually enlarged, until at last the entire shell can be removed without injury to the membranes.

**Preserving Ostracoda.\***—Dr. G. W. Müller finds that preservation in 70 per cent. alcohol is sufficient for the examination of the shells and appendages of Ostracoda. With some, especially the Halocrypidae, the shell is too soft for this method, and it is well to place such in Canada balsam, to preserve the form of the shell.

Preservation for histological purposes presents some difficulties, as the highly calcified shell is an obstacle to the entrance of the preservative fluid. The best results were obtained with a mixture of 5 parts ether and 1 part absolute alcohol, from which, after a minute, the specimens were removed to 70 per cent. spirit. Useful preparations may be made by destroying the shell of living animals, and placing them quickly in 70 per cent. alcohol.

**Study of Mitosis.†**—In his study of the variations of mitosis in *Ascaris megalcephala* M. V. Heda found that Prof. Van Beneden's method was the best for fixing the eggs; he used, that is, a mixture of 1 part glacial acetic acid with 5 parts of absolute alcohol; this mixture kills rapidly, while the achromatic elements remain very distinct. The best staining reagent appears to be vesuvin 0.25, malachite-green 0.25, distilled water 100, and glycerin 10 parts. The eggs, on removal from the fixing reagent, are at once placed in a drop of the staining fluid on a slide, and in this they are moved about. The preparation is then placed in a damp chamber for a day; a cover-glass is then put on, and at each of its four sides a drop of glycerin (with 1/3 water) is allowed to fall. If, on examination, the preparation appears worthy of a detailed study, it must be decolorized. This is done by putting a drop of aqueous solution of glycerin at one edge of the cover-glass, and drawing it through till there are only traces of the stain. The solution of glycerin should be 10 per cent. if the preparation has just been stained, 30 per cent. if it was stained a short time previously, and 50 per cent. if the preparation is old; this last solution may be employed for eggs set up some years since. It is well to have the worms as fresh as possible.

\* Fauna u. Flora des Golfes von Neapel, xxi. Ostracoda (1894) pp. 8 and 9.

† Arch. de Biol., xiii. ("1893") [1894] pp. 424 and 5.

## (3) Cutting, including Imbedding and Microtomes.

**Small Auxiliary Apparatus for the Plate Modelling Method.\***—Prof. F. Keibel describes a small graving tool which can be attached to

a microtome in order to mark the straight lines in the plate-modelling method. The apparatus consists of a stout brass hoop B (fig. 97), which fits over the knife of the microtome and is fixed by the screw S. To this hoop is fastened by means of two screws (of which only one *s* is shown in the figure) a steel plate *p*, bent at right angles, with its free end pointing downwards. On the free end small teeth are cut, which are arranged in groups and are sharpened on both sides, so that their section is as in fig. 98.

FIG. 97.

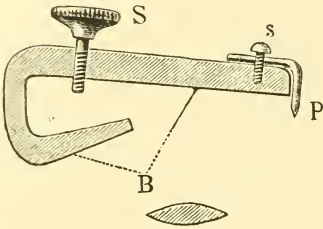

FIG. 98.

**Plate Models of Embryonic Livers.†**—Herr J. A. Hammer has studied the development of the liver in some Vertebrata by the method of plastic reconstruction of the object. The author followed the procedure as laid down by Born,‡ though some departures were made in details, perhaps the most important being the use of brown modelling wax, which is more plastic than the ordinary uncoloured plates. The material was fixed in saturated solution of sublimate and afterwards hardened in spirit to which a little iodine has been added. The sections varied from 10–20  $\mu$  in thickness. The objects were drawn under magnifications of 130–150, so that the epithelial cells of the liver, bile-duct, &c., were well seen.

**Methods for Examining Embryological Material.§**—Prof. C. Rabl recommends the following procedures for examining the vertebrate embryo:—

*Fixing.*—(1) Saturated aqueous solution of sublimate 1 vol., saturated aqueous solution of picric acid 1 vol., distilled water 2 vols. As a rule they are kept in this for about 12 hours; they are then washed for a couple of hours, and next transferred to weak spirit. The spirit is gradually increased in strength until it becomes absolute alcohol, to which a trace of tincture of iodine should be added. (2) Another fixative which gives even better results is 1 per cent. platinum chloride solution 1 vol., saturated aqueous solution of sublimate 1 vol., distilled water 2 vols. (3) Another mixture, the results of which are sometimes brilliant and sometimes doubtful, is 1 per cent. platinum chloride solution 1 vol., saturated aqueous solution of picric acid 2 vols., distilled water 7 vols. Any fixative which contains platinum chloride must be used in large quantity and often renewed. With other fixatives the author has not obtained such good results, e. g. pure sublimate and Flemming's fluid. Embryos of osseous fishes require to be plunged in hot fixative to prevent crumpling of the chorda and rupture of the muscles.

\* Zeitschr. f. wiss. Mikr., xi. (1894) pp. 162–3.

† Nova Acta R. S. Sci. Upsaliensis, xvi. (1893) p. 34 (2 pls.).

‡ See this Journal, 1884. § Zeitschr. f. wiss. Mikr., xi. (1894) pp. 164–72.

*Staining.*—Czokor's cochineal-alum is the best all-round stain for embryos and embryonic areas, but Delafield's hæmatoxylin, borax-carmin, safranin, &c., are very clear nuclear stains. The author makes his alum-cochineal by mixing about 25 gm. of powdered cochineal and an equal quantity of powdered alum in about 800 gm. of distilled water and evaporating down to 600 gm. The mixture must be constantly stirred. A small piece of thymol is added to the solution in order to prevent fungi growing, and when cold the solution is filtered. It stains better when fresh, and is therefore the reverse in this respect of Delafield's hæmatoxylin. According to size, the embryos remain in the stain for an hour to a day; they are then washed in water as long as any colour comes out. Embryos which have been hardened in a solution containing platinum chloride should be stained as soon as possible (within a week), otherwise they stain badly or not at all. Before staining all the alcohol must be removed.

*Embedding and Cutting.*—Embryos are imbedded from chloroform or from bergamot oil. It is advisable to make the change from absolute alcohol to bergamot oil or chloroform a gradual one. The objects are first soaked in paraffin with a melting-point of 45°, and are then placed in paraffin of 56° melting-point heated in a water-bath to 80°–90°. It is of importance that all the chloroform or bergamot oil should have been driven off, otherwise the sections crumble. In dealing with fragile or brittle objects (e. g. lens, or if air has got into the preparation) it is advisable to brush over the surface of the paraffin block a layer of paraffin heated in a water-bath. By this device the section may be lifted off the knife with safety, and it does not curl itself up.

*Adhesion of Sections.*—Schällibaum's solution is used by the author for sticking the sections to the slide, and they are made to adhere firmly by treating them with the following mixture, which must be freshly made every four or five days:—new clear oil of cloves 3 parts and 2 parts of perfectly clear collodion. When stuck on with this mixture the sections adhere so firmly that they may be immersed in absolute alcohol for a whole day, and may be stained and decolorized as desired.

This adhesion-method has the further advantage of allowing a series of sections to be examined a few minutes after they have been cut, for supposing no further after treatment is required, the paraffin is soon melted off over a Bunsen burner, and then the slide can be at once transferred to xylol. As a mounting medium the author uses xylol-dammar, and always warms the cover-glass before imposing it.

*Use of Stabilite for Celloidin Preparations.\**—Herr O. Jelinek recommends the use of the new insulating material stabilite in preference to wood or cork on which to fasten the celloidin block. The disadvantage of the use of wood or cork for this purpose is that colouring matter and tannic acid are extracted from them by immersion in alcohol. In seeking for some material to replace them the author was guided by the following considerations. The substance must be perfectly insoluble in water and alcohol; it must be possible to easily cut from it blocks of different size and shape with the knife or saw, and these blocks must be hard and not alter their shape by clamping; the celloidin must adhere

\* Zeitschr. f. wiss. Mikr., xi. (1894) pp. 237-42.



firmly to it; it must be possible to write on the blocks without danger of the writing being easily effaced; and finally the substance must not be costly. According to the author, *stabilite*, the insulating material supplied by the *Electricitäts-Gesellschaft* of Berlin, answers all these requirements very satisfactorily. It has a specific gravity of 1.6, so that it sinks in alcohol; it is not hygroscopic, is insoluble in water and alcohol, and is not attacked even by hydrochloric and dilute sulphuric acids. It can be easily cut with a saw, and takes a good polish, and it is possible to easily write upon it either with a pencil or with ink.

**Glass Receptacle for Series of Sections.\***—Prof. J. Schaffer describes a new form of receptacle for series of sections, in which the object-holders can be placed with their long-diameter vertical, so that a considerable saving in liquid (alcohol, xylol, &c.) is effected. The

FIG. 99.

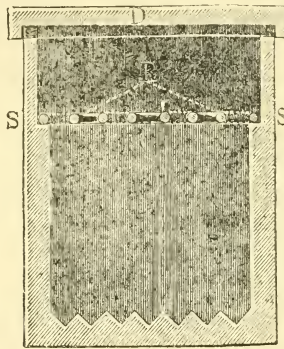

FIG. 100.

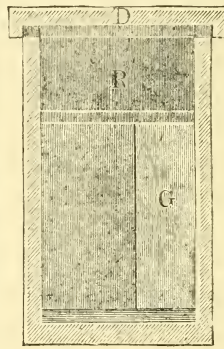
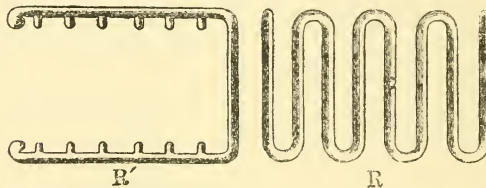

FIG. 101.



vessel is of strong glass, and has cubic contents of  $8.3 \times 6.2 \times 4.4$  cm.; at the bottom are seven grooves (fig. 99), which receive the lower ends of the object-holders, while the upper ends are held by the glass grating R resting upon the two projections SS. The cover D fits on tightly by means of a deep rim. The grating is either a bent glass rod with parallel folds (fig. 101, R), or has the form shown at R'. The latter is intended for the large paraffin size,  $36 \times 76$  cm., the former for the smaller size. The amount of liquid required for seven wide object-holders is 100 ccm. When the small (25 mm.) object-holders are used the amount of liquid may be diminished to 80 ccm. by placing a glass block (fig. 100 at G) in the vessel.

\* *Zeitschr. f. wiss. Micr.*, xi. (1894) pp. 150-3.



## (4) Staining and Injecting.

**Modification of Golgi Silver Stain.\***—Dr. H. J. Berkley has chiefly followed, in the investigation of the nerves of the liver, the rapid Golgi method, but he did not always get with it the finest details. He recommends, therefore, the following modifications:—The tissue is cut into slices not more than 1.5 mm. thick, and while warm is immersed in a saturated solution of picric acid diluted with an equal volume of warm water. After being in it for from 15 to 30 minutes it is immersed, without washing, in the hardening fluid, where it remains for forty-eight hours or longer. This fluid should consist of aqueous solution bichromate of potash 100 parts (saturated in the sunlight), and solution of 2 per cent. osmic acid, 16 parts. The solution is to be exposed to full sunlight to age, but all specimens are to be hardened in absolute darkness at a temperature not lower than 25° C.

After the expiration of the 48 hours the specimens are treated with the silver solutions of 0.25 and 0.75 per cent. in the usual manner, and allowed to remain in them five or six days. After very rapid washing in running water they are rapidly dehydrated, immersed for a few minutes in celloidin, placed on a cork, and the celloidin hardened in 75 per cent. alcohol in a closed jar; this jar is cooled so as to harden the celloidin as rapidly as possible. The sections are cut under 95 per cent. alcohol, rapidly dehydrated, cleared in oil of bergamot, and mounted in xylol-balsam without cover-slip.

The osmium-copper-hæmatoxylin method and various gold methods were tried, but the results do not appear to have been very satisfactory.

**Staining Intrinsic Pulmonary Nerves of Mammalia.†**—For these nerves Dr. H. J. Berkley found that the picrid-acid-osmium-bichromate modification gave incomparably better results than the rapid Golgi method, the latter allowing no definite distinction to be made between medullated and non-medullated nerves.

**Nerve-Supply of Cardiac Ventricles.‡**—The same author reports that very considerable differences are found in the staining by the silver methods of the nerve elements in the muscular tissue of the cardiac ventricle. These variations in the staining action of the silver salt account in large measure for the discrepancies that exist between different observers that have used Golgi's method.

**Staining Living Cells.§**—Dr. G. Galeotti finds, from numerous experiments on animals and plants, that living cells never stain altogether, owing to their vital energy, which prevents the colouring matters from becoming diffused in their protoplasm. It is, however, possible to stain some elements of living cells, and those are they which do not take any active part in the functions of the cells; such are the supposed nutritive substances of the cytoplasm and secretory products destined to be expelled. It cannot therefore be admitted that there is a vital staining reaction for the nervous system in the sense of Ehrlich, or in that of Schultze and Mitrophanow for the cytoplasmic granules, for the staining

\* Johns Hopkins Hospital Reports, iv. (1894) pp. 216-9.

† Tom. cit., p. 241.

‡ Tom. cit., p. 250.

§ Zeitschr. f. wiss. Mikr., xi. (1894) pp. 172-207.

of the whole anatomical element is the sign of its death. Partial staining of a living cell indicates that the coloured part no longer possesses any activity. In discussing partial staining the author demands the following postulates:—The colouring matter must not be toxic to the cellular protoplasm; there must be an elective relation between the cell-elements and the stain; the stain must be stable and capable of resisting the reducing power of the living cell.

For his experiments the author used the salamander, the frog, and the iris, and these were treated with twenty-four pigments. The salamanders received an intraperitoneal injection of a solution of the dye in sodium chloride. From the frogs a piece of mucosa was removed from the palate and then placed in the staining solution. The iris flowers were immersed in an aqueous solution of the pigment.'

**Artificial Colouring of Wine with Vegetable Substances.\***—Sig. A. Scala finds that nitrite of potassium or formaldehyde added to a natural red wine will precipitate the colouring matter, leaving a liquid golden-yellow in the first case, cherry-red in the second. Extrinsic vegetable colouring matters from the fruits of elder, *Phytolacca*, &c., are not precipitated, and may thus be detected. Some anilin-reds behave in the same way. The first reagent mentioned is more trustworthy than the second.

**Rapid Staining of Blood Corpuscles.†**—Dr. H. Seelmann points out that Ehrlich's method of differentiating red from white blood-corpuscles demands too much time and apparatus to be suitable for the busy physician. His method is as follows:—A drop of blood is placed on a slightly warmed cover-glass, dried, and fixed for five minutes in absolute alcohol; the preparation is then placed in a saturated alcoholic solution of eosin with the addition of a quarter the volume of water; it remains there half a minute and is then transferred to an aqueous alcoholic solution of methylen-blue (1:85 of water, 15 of absolute alcohol) for about 2-2.5 minutes; thereafter it is put on the slide and examined wet, or dried and covered with balsam. The red corpuscles become brown-red; the nuclei of the white corpuscles dark blue; the protoplasm a delicate bright blue; and eosinophilous cells are similarly stained. The preparations cannot be compared with Ehrlich's, but they are sufficiently clear for an estimate of the proportions of red and white corpuscles, and they are made rapidly.

**Flagella-Staining without a Mordant.‡**—Dr. W. Hessert stains flagella, using no mordant, in the following way:—A young agar culture is suspended in distilled water, and a film made on a cover-glass. When dry, the film is fixed either by passing the cover-glass through the flame or by treating it with a saturated alcoholic solution of sublimate. In the latter case it must afterwards be washed. When fixed, the preparations are treated for 30 to 40 minutes with the staining solution, which is frequently heated. The cover-glass is then washed, dried, and mounted in Canada balsam. The staining solution recommended is a 10 per cent. aqueous dilution of a saturated alcoholic solution of fuchsin.

\* Ann. Ist. d' Igiene Sper. Univ. Roma, iv. (1894) pp. 167-76.

† Biol. Centralbl., xiv. (1894) pp. 687-8.

‡ Centralbl. f. Bakteriol. u. Parasitenk., xvi. (1894) pp. 346-7.

In this simple way the flagella of many bacteria may be effectively stained, though the pictures are perhaps not so striking as by Loeffler's method.

**Spore-staining after Maceration.\***—Prof. P. Ernst reports some researches made by Dr. Kinscherf on the staining of spores after macerating the preparations. The basis of the method presupposes that the difficulty of staining spores depends on the thickness and impenetrability of the spore membrane and not on any special characters of the spore plasma. By maceration this resistance may be overcome. The methods adopted are given very curtly, e. g. *Bac. subtilis* 13–15 minutes in 5 per cent. chromic acid, water, 18 hours in gentian-violet-anilin-water, 2–3 minutes in Lugol's solution. Günther's acid alcohol, 96 per cent. alcohol, water, Bismarck brown. An excellent contrast stain. Potato bacillus, 18 minutes in 5 per cent. chromic acid, 18 hours in Ehrlich's solution, &c. Root bacillus, 15 minutes in 5 per cent. chromic acid, &c. *Mesentericus vulgaris*, 30 minutes in 5 per cent. chromic acid, &c. Anthrax, 23 minutes 5 per cent. chromic acid, 18 hours Ehrlich's solution, 33 per cent.  $\text{HNO}_3$  (= tubercle stain). Also by Günther-Gram and thirdly by Lustgarten, 5 seconds in 5 per cent. permanganate of potash, 3 seconds in aqueous solution of sulphurous acid. Anthrax cultivations showing many free spores, were macerated from 18 to 20 hours in chromic acid, and afterwards treated with aqueous fuchsin solution, or with Bismarck brown. In such preparations the spores were stained in a short time.

**Staining Micro-organisms in the Blood.†**—M. H. Vincent adopts the following procedure for staining micro-organisms in blood preparations. The blood-film is prepared in the usual way, and then the cover-glass is treated for 1/2–2 minutes with the following mixture:—5 per cent. carbolic acid 6·0; saturated salt solution 30·0; glycerin 30·0. The solution is to be filtered. This fluid dissolves the hæmoglobin, does not alter the shape of the red corpuscles and causes no precipitate. The fluid is drained off, and the preparation after having been washed in distilled water is stained with carbol-methylen-blue plus 1–2 per cent. aqueous methyl-violet solution.

This method is also useful for showing the malaria plasmodia.

(5) Mounting, including Slides, Preservative Fluids, &c.

**Production of Artefacts by certain Fixatives.‡**—Dr. A. P. Ohlmacher in a critique of the Sporozoon theory of malignant neoplasms from a micro-technical standpoint, records his experience of different fixatives, followed by different stains, on the Myxosporidia found in the kidney tubules of toads. These Sporozoa are only found in the spore form, exist in great numbers in the renal tubules, and are excellently adapted for controlling the results obtained from cancerous tumours. The author found that solutions containing chromic acid or osmic acid are unsuited for the preservation of Myxosporidia, while absolute alcohol and Carnoy's chloroform-acetic alcohol gave excellent results. Corrosive sublimate, while fixing and hardening well, is a little inconvenient

\* Centralbl. f. Bakteriol. u. Parasitenk., xvi. (1894) pp. 182–4.

† Gaz. Méd. de Paris, 1894, p. 296. ‡ Journ. Amer. Méd. Assoc., June 30, 1894.

as the crystals are sometimes very difficult to remove. The author condemns the inferences drawn by many investigators of carcinomata in organs, chiefly on the ground that their results have been obtained by using fixatives which do not preserve spores well, and which produce curious artefacts in the stained spores, distorted by the fixing fluids.

**Zenker's Fixative.\***—Dr. K. Zenker recommends as a fixative the following solution:—Distilled water 100·0, sublimate 5·0, bichromate of potash 2·5, sulphate of soda 1·0, acetic acid 5·0. Though the solution keeps well, it is better to add the acetic acid shortly before using it. Pieces 1 cm. thick are perfectly hard in less than 24 hours. The after treatment consists in washing well in running water, and then dehydrating in alcohols of increasing strength. If any sublimate remain it may be removed either from the piece or from the sections by means of iodine alcohol. No distortion occurs during the after-hardening in spirit. The sections stain well.

**Formol as a Preservative Fluid.†**—Herr J. Blum is strongly impressed with the value of formol as a preservative fluid. Formol is a 40 per cent. solution of formaldehyde, and comparatively recently has come much into vogue for preserving museum specimens for microscopical and also for bacteriological work. Animals hardened in formol preserve to a great extent their natural form and colour; their eyes are clearer than in spirit. Mucin is not coagulated, and retains its transparency. Blood colouring matter of tissues and organs placed in formol apparently disappears, but on immersing the object in not too weak spirit (60–90 per cent.) the characteristic colour is restored. Vegetable tissues and structures are also well preserved in formol. Chlorophyll is not extracted, though it appears to undergo some change, which varies with the plant. Microscopical sections of plants preserved in formol give excellent pictures. Diluted formol does not burn, and is cheaper than alcohol.

**Pacini's Preserving Fluid.‡**—Prof. A. Lustig has examined cholera dejecta which had been kept in Pacini's fluid since 1831. The fluid consists of mercury chloride 1, sodium chloride 2, distilled water 200. The composition of the mixture was in Pacini's own writing.

Microscopical examination of the yellowish-white sticky mass at the bottom of the vessel showed that the organisms were well preserved, the predominating form being a curved bacillus, with thin rounded ends, about the length and thickness of the comma bacillus. Stained cover-glass preparations were also very good. The author points out that this fluid must be an excellent medium for preserving material for microscopical examination.

**Fixing Methods and the Granula.§**—Dr. A. Fischer has some criticism of fixing methods. Chromic acid (·5 per cent.), osmium acid (1 per cent.), Altmann's mixture of 1 per cent. osmic acid and 2·5 per cent. bichromate of potassium and other fixatives cause solutions of

\* Münchener Med. Wochenschr., 1894, No. 27. See Centralbl. f. Bakteriol. u. Parasitenk., xvi. (1894) pp. 542–3.

† Bericht Senkenbergische Naturf. Gesell., 1894, pp. 195–204.

‡ Centralbl. f. Bakteriol. u. Parasitenk., xvi. (1894) pp. 326–8.

§ Anat. Anzeig., ix. (1894) pp. 678–80.



peptones to assume a granula form. The granules may be soluble or insoluble; they may be stained with acid fuchsin and picric alcohol; they are not distinguishable from Altmann's granula. These facts suggest the question whether Altmann's granula is not an artificial product due to peptone or propeptone in the animal cells. Peptone solution injected into empty pith cells, and then fixed with osmic acid or Altmann's mixture, gave rise to a strikingly close imitation of vegetable cell-structure.

**Preserving Tow-net Material.\***—Mr. J. Rattray never adopted pure alcohol *ab initio* for the preservation of tow-net material, but 70 or 80 per cent. alcohol, with a small addition of pure hydrochloric acid and a trace of picric. After washing with strong spirit to remove the acid, the specimens were preserved in spirit. Alger's adaptation of Kleinenberg's formula was often used, because of its reported high degree of penetrability for chitinized structures; the fixing agent was simply added to the sea water, and was succeeded by increasing strengths of spirit. Mayer's picro-hydrochloric method was only employed a few times. Corrosive sublimate was extensively used, Lang's methods being simplified and accelerated by adding a little of the solid salt to the sea water. In a few cases, following Carnoy, a trace of acetic acid was added to the corrosive solution.

**New Compressorium.†**—Prof. H. E. Ziegler has devised a small apparatus by means of which a well-regulated pressure can be applied to the object, while at the same time a stream of fresh water or any other liquid can be drawn through it.

The apparatus (fig. 102) consists of two metal plates, of which the lower serves as object-holder, while the upper carries the cover-glass.

FIG. 102.

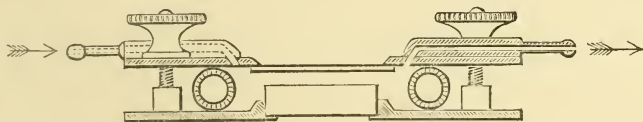

In each plate there is an aperture in the centre. On the opening of the lower plate a round piece of thick glass is fixed, while below the opening of the upper the cover-glass is cemented. The two plates are kept apart by a hollow caoutchouc ring, and can be pressed together by three pressure-screws. A constant stream of water can be passed through the space between the caoutchouc ring and the plates by means of the two tubes in the upper plate. The stream of water is regulated by a stop-cock. A small U-tube is attached to the exit-tube to prevent any effect of suction on the water in the apparatus.

The brass parts of the apparatus are protected from the injurious effect of reagents by lacquer, but it is advisable to have two apparatus, one of which should be kept free from reagents.

\* Trans. Linn. Soc. London, Zool., vi. (1894) pp. 4 and 5.

† Zool. Anzeig., xvii. (1894) pp. 330-2 and 345-7.

The author has made use of the apparatus for observations of different marine larvæ and small worms, of Rotatoria and Infusoria, and also of the eggs of *Crenilabrus pavo*.

(6) Miscellaneous.

Collection of Microscopic Preparations.\*—Dr. Beneke pleads for the institution of more systematic collections of microscopic preparations, not only in the seats of learning, but in central stations or museums. He points out, as a little consideration makes quite evident, that the lack of system, centralization, and availability involves a serious waste of energy. He pleads, in other words, for the institution of libraries for the real documents of histology.

Mr. A. Sedgwick, F.R.S., informs us that there are at Cambridge—

(1) Fairly complete series of sections of embryos of Cape *Peripatus*. A few series of *Peripatus* embryos of West Indian and New Zealand species.

(2) Sections of Elasmobranch embryos; fairly complete series of *Pristiurus*, less complete of *Scyllium* and *Acanthias*; a few series of *Raja*—in the possession of Mr. A. Sedgwick.

(3) Series of sections of embryos and larvæ of many Polyzoa, and of adult *Cephalodiscus* in the possession of Mr. E. F. Harmer.

(4) Series of *Petromyzon* embryos and larvæ in the possession of Mr. A. E. Shipley.

Fixing-board for Experiments on Animals.†—M. A. Latapie describes an apparatus for fixing animals securely during experiments in the laboratory, a feature of which is that the animal can be turned over from front to back without untying the hind legs. It consists of a board 0·3 m. long and 0·14 m. broad; at each end there is an arrangement, one for fixing the head, the other the neck or head. The hind piece is a metal plate, which slips along a fixing screw and has in front a slightly curved metal rod. This can turn round a vertical axis. At each end of the rod is a sort of loop which can be turned right or left. When the hind legs have been stretched by the cross-piece the rings are made to embrace the projecting angle formed by the leg on the thigh. A spring keeps them in position, and thus the hind legs are held tight.

The head is fixed by stretching the head or throat over the block and fastening it down with a rod. A muzzle serves to complete the fixation of the head. For pigeons or fowls a couple of hooks like those used by Malassez are supplied. When both head and hind-legs have been fixed, the proper extension is given by drawing apart the head and tail pieces. The front legs are secured by a couple of rings and a chain.

The board carries two hind leg pieces, the second one being for small animals.

\* Biol. Centralbl., xiv. (1894) pp. 718-20.

† Ann. Inst. Pasteur, viii. (1894) pp. 668-78 (1 fig.).

## PROCEEDINGS OF THE SOCIETY.

MEETING OF 17TH OCTOBER, 1894, AT 20 HANOVER SQUARE, W.  
THE REV. EDMUND CARR, M.A., IN THE CHAIR.

The Minutes of the Meeting of 20th June last were read and confirmed, and were signed by the Chairman.

The List of Donations to the Society (exclusive of exchanges and reprints) received since the last meeting was submitted, and thanks for the same were voted to the donors.

	From
De Blainville, Manuel d'Actinologie. (Svo, Paris, 1834) .. ..	<i>Prof. F. J. Bell.</i>
E. Heron-Allen, Prolegomena towards the Study of the Chalk Foraminifera. (Svo, London, 1894) .. ..	<i>The Author.</i>
6 Photomicrographs, in frame .. ..	<i>Mr. A. Pringle.</i>
6 Slides of Foraminifera .. ..	<i>Mr. J. J. Harvey.</i>
A Slide of Diatoms .. ..	<i>Mr. H. Morland.</i>

Prof. F. Jeffrey Bell said that, following the excellent example of Mr. T. Charters White, Mr. Andrew Pringle had presented to the Society the photomicrographs which he sent, as part of the Society's exhibit, to the Chicago Exhibition. He felt sure that the Fellows of the Society would be glad to return their thanks to Mr. Pringle for these very excellent examples of what could be done in this way. Mr. J. J. Harvey had presented to the Society six excellent slides illustrating the method of mounting Foraminifera described by him at the meeting in June last; and they had also another slide, from Mr. Morland, containing some very curious forms of *Terpsinoe intermedia*. They had also received a pamphlet from Mr. Heron-Allen on the Chalk Foraminifera. He did not propose to read it, but thought Mr. Chapman had done so and might be able to say something about it.

Mr. Chapman said he had seen this paper, and thought that the latter part of it was likely to be useful for reference as a sort of index to the Foraminifera of the Upper Chalk.

Dr. W. H. Dallinger said that Messrs. Watson had sent for exhibition a new model Microscope, which appeared in general principle to resemble their "Van Heurck" Microscope, but had a few differences which would commend themselves to notice. The stage rotated completely, which was certainly an advantage, and it was provided with a centering arrangement which was said to work accurately; and the plan was adopted of working two milled heads upon one centre, as in Powell and Lealand's Microscope. Then the spread of the foot was 10 in., which gave it an exceedingly solid basis, and it had a 10-in. optical centre. The instrument itself was very well made; and, on the whole, he should be quite content to say that it looked like a thoroughly efficient and high class Microscope.

Messrs. Ross & Co. also sent for exhibition examples of their "Eclipse" Microscope, with ring-stand, tripod-stand, and the rigid form. They also exhibited a Petrological Microscope, and a new pattern binocular stand.

Prof. Bell said they had received, through Sir H. Trueman Wood, a copy of the Award of the Commission of the Chicago Exhibition.

Mr. R. T. Lewis said he had placed under one of the Microscopes upon the table a slide which had been sent by Mr. Arnold W. Cooper, of Richmond, Natal. The objects mounted were some curious parasites found upon a penguin which was captured upon the sea-shore at Isipingo, a short distance south of Durban. Their general characters, especially the clavate antennæ and palpi, seemed to place them in the family of *Liotheidæ*, and the possession of two claws in this case would refer them to the genus *Liotheum*, but whether or not they were a new species had not yet been conclusively ascertained. If any of the Fellows of the Society present were able to recognize them, Mr. Cooper would be very glad to receive information.

A note by Dr. H. Stolterfoth, "On the genus *Corethron*," was communicated by the Secretary. The paper was illustrated by photomicrographs, and also by slides exhibited under Microscopes in the room.

Dr. Stolterfoth stated that he had carefully washed the material sent him by Prof. D'Arcy Thompson (from the Atlantic) so as to get the forms into pure water. "I then burnt a number of preparations on the cover-glass, so as to preserve these delicate structures as much as possible in their original condition. As Count Castracane had expressed some doubt as to their siliceous nature, I boiled some of the material in sulphuric and nitric acid, and in this way proved their undoubted siliceous character. . . . I have only been able to find one species, and that I have identified as *Corethron criophilum* Cast. This form varies much, both in appearance and size. From careful measurement, the length of the valve without the hairs varies from 1/150 in. to 1/100 in., but the greatest difference is in the breadth of the valves, which varies from 1/350 in. to 1/850 in. This difference in size is met with in many species of diatoms, and, when seen in all its varying proportions, in no way leads us to suppose different species.

"The generic definition given by Count Castracane is 'Frustulia cylindrica, libera (?), valvis convexis, setarum radiantium corona cinctis.' The query as to 'libera' I think may be omitted, as I have never found two valves united. In the forms I examined the connecting zones were smooth, and readily broke up into rings, seen in the slide prepared from boiling in acid. After I had burnt the material on the cover-glass, I mounted the slides in styrax, and from these preparations I have made five photographs illustrating the form and its structure. The mode of growth I have shown in a diagram, which demonstrates how from one valve the two new forms are developed, for the zone B falls away, and the hairs contained in the sheath spring out and furnish the hairs at the end of the new valves. . . . The direction in which these hairs lie is sometimes opposite, and, these forms being surface diatoms,



the hairs contribute much to their power of flotation. . . . The exact relationship of this genus is difficult to make out. In some ways it is related to *Rhizosolenia*, and also to the genera *Stephanogonia*, *Periptera* and *Stephanopyxis* of Van Heurck. On the whole, this genus *Corethron* is essentially Arctic in its habitat, and, with the exception of the present gatherings, has never been seen in a free growing state."

Mr. E. B. Green read a paper "On some Parasitic Growths on the Root-hairs of Plants," and illustrated his subject by specimens and drawings.

Mr. A. W. Bennett said that Mr. Green had shown him his slides and drawings before the Meeting, and, without expressing any decided opinion upon the question as raised by Mr. Green, he might admit in the first place that he was quite justified in saying that what had been written about the subject in text-books and elsewhere was very unsatisfactory. It was well known that the root-hairs of plants exuded a kind of mucus, which was frequently acid, but the fact that this was powerful enough to corrode glass was certainly interesting. With regard to the parasites, some were familiar and some unusual, and he hoped Mr. Green would pursue his investigations concerning them. Mr. Green distinguished his parasites from Mycorrhiza, which added to the nutritive power of the roots of the plants on which they grew, while in his opinion these were only destructive in their action. He would not express any opinion on that at present; but he confessed himself to be exceedingly sceptical as to the so-called spores, because, if the observation was correct, it would be an entirely new one, and because it was so easy to mistake parasites for spores. There was no doubt that the blue-green algæ were found in soil, and in close contact with plants, and it was not at all incredible that they might in some cases become parasites. Mr. Green had brought these ideas upon the subject before them, not with any idea of dogmatizing upon it, but rather to elicit further information; and it was quite apparent that this was a branch of enquiry open to all who were interested in such subjects, and one which might be reasonably expected to lead to very useful results.

The thanks of the Society were voted to Mr. Green for his paper.

Prof. Bell said he did not think they ought to let pass the intimation they had received of the death of Dr. G. E. Blenkins, who had been a Fellow of the Society since 1848, and was at one time a Member of the Council and Secretary.

Mr. F. Chapman read a further paper, in continuation of his series, on the Foraminifera of the Gault of Folkestone, in which he described 27 species of the genus *Cristellaria*, of which three were new (see p. 645).

The Chairman said the Society was again greatly indebted to Mr. Chapman for this paper, and for the very excellent drawings by which it was accompanied.

Prof. Bell said that he had made some remarks on the six preceding parts of Mr. Chapman's description of the Foraminifera of the Gault, and could only repeat what he said some time ago—that he greatly regretted that they did not know earlier what kind of a contributor they had in

Mr. Chapman, as they would otherwise have had a sufficient number of copies printed off to enable them to have published the whole series as a separate monograph. Those who only knew these contributions from the short résumé which Mr. Chapman had given them of each could form little idea of the actual value of such a series, although they were no doubt aware that it did not always follow that the most interesting addresses were those which were the most important.

Prof. Bell said they had received a paper from Mr. E. M. Nelson "On Measuring the Refractive Indices of Various Media." This communication was no doubt a very valuable contribution to the subject, and if Mr. Nelson had been able to be present, he would probably have explained the general purport of it to the meeting. He was, unfortunately, unable to be present, and therefore since the text consisted largely of mathematical formulæ, he proposed to keep the paper back until their next meeting, in the hope that Mr. Nelson would then be with them.

The following Instruments, Objects, &c., were exhibited:—

The Society:—Slides from Messrs. Harvey and Morland:—Photomicrographs from Mr. Pringle.

Mr. F. Chapman:—Foraminifera illustrating his paper.

Dr. W. H. Dallinger:—Microscope by Messrs. Watson.

Mr. T. D. Esser:—Tobacco Bug from Cuba.

Mr. E. B. Green:—Slides and Drawings illustrating his paper.

Mr. R. T. Lewis:—Parasites found on a Penguin.

Messrs. Ross:—The "Eclipse" Microscope.

Mr. C. F. Rousselet:—*Euchlanis triquetra*—mounted.

New Fellows:—The following were elected *Ordinary* Fellows:—Messrs. Henry Hudson Anderson, Edwin James Seymour and William Hobbes Shrubsole.

MEETING OF 21ST NOVEMBER, 1894, AT 20 HANOVER SQUARE, W.

THE PRESIDENT (A. D. MICHAEL, ESQ., F.L.S.) IN THE CHAIR.

The Minutes of the Meeting of 17th October last were read and confirmed, and were signed by the President.

The List of Donations (exclusive of exchanges and reprints) received since the last meeting was submitted, and the thanks of the Society were voted to the donors.

Annual Report of the Bureau of Ethnology. (Svo, Washington, 1893)	} The Smithsonian Institution.
P. T. Cleve, Synopsis of Naviculoid Diatoms. Part I. (4to, Stockholm, 1894)	
W. P. Manton, Syllabus of Lectures on Human Embryology. (Svo, Philadelphia, 1894)	The Author.
Two Slides of S. African Diatoms	Mr. A. W. Cooper.

Mr. T. Comber, in reply to the Secretary, said that he had examined this first part of Prof. Cleve's work, and thought it was, without exception, the finest contribution to diatomic literature which had ever been produced; the second part, he understood, was already in the press. It represented the careful work of eight years, and had been carried out during the intervals of other duties at the University of Upsala. Prof. Cleve, he was glad to say, would probably be in London during the next week to receive the Davy Medal from the Royal Society. He had in his new work made a great alteration in classification, having broken up that great and unwieldy genus *Navicula* into a number of others, and had also united into one species many varieties which had, without sufficient reason, been named as different species—and in doing this he had undoubtedly taken a long step in the right direction. He thought their best thanks were due to Prof. Cleve for favouring them with a copy of the first part of this valuable work, which would no doubt be followed by the second part as soon as it was ready for publication.

Prof. Bell said they had received two slides of South African diatoms from Mr. A. W. Cooper, of Natal, accompanied by a letter which he read to the meeting. The slides had been sent to Mr. E. Grove for examination, who had returned them with the following exhaustive report:—

DIATOMACEÆ observed in slides from the Umtwalumi River, Natal.  
Nov. 1st, 1894.

*Achnanthes inflata* K. One lower valve seen.

*Amphora delphinea* Bail. ? Small form, doubtful.

\* *A. ovalis* K.

*Amphiprora lepidoptera* var. *proboscidea* Cl. (S. N. D., p. 25). So far as I can judge from one or two specimens in a very unfavourable state for observation, this is the above variety, which is described by Cleve as occurring in B. W. at Cameroons.

*Cocconeis Placentula* E. Very small form.

*Cyclotella striata* K. Very scarce, a B. W. species.

\* *Cymatopleura Solea* (Bréb.) W. S.

\* *Cymbella bengalensis* Grun.

*C.* sp. ? Resembles *C. helvetica* K. in outline, but has coarser, more radial striæ, and broader axial area. I cannot identify it with any of Cleve's species in S. N. D. Perhaps entitled to rank as a new species.

\* *C. parva* W. S.

\* *C. (Encyonema) turgida* Greg.

*C. (Encyonema) ventricosa* K.

\* *Epithemia gibba* K. Very abundant.

\* *E. (turgida* var.) *Westermanii* E. This appears to be the form in Mr. Cooper's sketch.

\* *E. Zebra* K.

*Eunotia bidentula* W. S. A variety with four elevations. Scarce.

*E. Eruca* E. One small valve seen. An Australian species.

*E. monodon, diodon, triodon* Ehr.

\* *Fragilaria capucina* var. *acuta* Grun. (V. H. S., xlv. 4).

- \**F. mutabilis* (W. S.) Grun.  
 \**F. Harrisonii* (W. S.) Grun. (*Staurosira* E.)  
 \**Gomphonema braziliense* Grun.  
 \**G. parvulum* K.  
*G. subclavatum* Grun.  
 \**G. ventricosum* Greg. var., doubtful.  
 \**Mastogloia Danseii* Thw.  
 \**M. Smithii* Thw. (The form  $\beta$  of the S. B. D.)  
*Navicula ambigua* E.  
*N. (Pinnularia) appendiculata* K.  
*N. Bacillum* E.  
*N. biceps* Greg. forma *stauroneiformis* Cl. (*P. interrupta* W. S.)  
*N. binodis* W. S. One specimen only seen.  
*N. cryptocephala* K.  
 \**N. cuspidata* K. var. Shorter than the type, and with obtuser ends. Perhaps the var. *danaica* Grun. described by Cleve (S. N. D., p. 110).  
*N. (Diploneis) interrupta* K. (a B. W. species).  
 \**N. (Diploneis) elliptica* K.  
 \**N. (Pinnularia) gibba* W. S.  
 \**N. limosa* K., and ditto var. *gibberula* Grun.  
 \**N. limosa* var. *alpina* Cl. The ends of this little form are not so much rounded as Cleve's var., but it comes very near to it.  
 \**N. (Pinnularia) mesolepta* var. *stauroneiformis* E.  
 \**N. radiosa* K.  
 \**N. radiosa* var. *tenella* (Bréb.) Cl.  
*N. (Pinnularia) subacuta* E.  
*N. (Frustulia) vulgaris* (Thw.) Cl. (*Coll. vulgare* Thw.)  
 \**Nitzschia amphibia* Grun.  
*N. amphioxys* E.  
 \**N. (Tryblionella) angustata* W. S. Longer, and with acuter ends than type.  
 \**N. Denticula* Grun. (*Denticula obtusa* W. S.)  
*N. fluminensis* Grun. Narrower than type. Perhaps a form of *N. paradoxa* (W. S.) Grun. Scarce.  
*N. marina* Grun. A marine species; one specimen seen.  
 \**N. Sigma* W. S. var. A delicate form of *N. Sigma* which I have frequently observed in fresh or very slightly salt water.  
 \**N. Tryblionella* Hantzsch var. *Victoriæ* Grun. Abundant. This is a short broad form of the *Tryb. elegans* W. S.  
*Pleurosigma acuminatum* K. (*P. lacustre* W. S.) One specimen seen.  
 \**P. Spencerii* W. S.  
*Schizostauron crucicula* Grun. (Cl. N. & R. D., 1881, p. 16, pl. iii. 44). This interesting little diatom has a bifid stauros, the ends of which are very divergent, so as to present the appearance of a St. Andrew's cross. It is not rare in these slides, but for the most part obscured by the dirt and debris. I note, by Maltwood, three specimens, viz. Slide 1  $\frac{31}{5}$ , Slide 2  $\frac{28}{0}$ ,  $\frac{29}{2}$ .  
 \**Stauroneis acuta* W. S.  
*S. Phœnicenteron* E.  
*S. pachycephala* Cl. (N. & R. D., 1881, p. 15, pl. iii. 42). Described by Cleve as occurring in fresh, or slightly brackish water in S. Africa.



It is rare, or concealed by the debris, in these slides, and I note two specimens, at Slide 1  $\frac{3}{16}$ , and Slide 2  $\frac{2}{8}$ .

*Surirella robusta* E. Fragments observed.

\**Synedra longissima* W. S. (V. H. S., xxxviii. 3). Very abundant.

\**S. Ulva* E.

I find at  $\frac{3}{16}$ ,  $\frac{2}{6}$ ,  $\frac{2}{6}$ , Slide 2, and elsewhere, a diatom which is new to me, V. lanceolate with subacute ends, and a central constriction in one side. Dimensions (of specimen  $\frac{3}{16}$ ): length, 0.05 mm.; breadth, 0.01 mm. across lobes; striæ parallel, 13 in 0.01 mm., faintly punctate. The structure suggests *Nitzschia*, though if the keel is, as appears to me, on the convex side, it is in form unlike any species of that genus. Further examination under more favourable circumstances, especially of a frustule if it could be obtained, is necessary to determine this diatom.

In the above list I have marked \* the most numerous species. All are of freshwater habitat, excepting the four species specially noted as brackish or marine.

The list presents no special facies, and, with the exception of a few forms which are not abundant, the species enumerated might be met with in any British gathering not far from the mouth of a river.

The only species as yet recorded only from S. Africa, in addition to the *Nitzschioid* (?) form I have sketched, and possibly the doubtful *Cymbella*, is *Stauroneis pachycephala* Cl.

#### Abbreviations used for References.

- S. N. D.—Synopsis of the Naviculoid Diatomaceæ. Cleve. (Stockholm, 1894)  
 D. E. N.—Diatomées Espèces nouvelles. Brun. (Geneva, 1891.)  
 V. H. S.—Synopsis of the Diatomaceæ of Belgium. (Van Heurck.)  
 N. & R. D.—On some new and little known Diatoms. Cleve. (Stockholm, 1881.)  
 S. B. D.—Smith's Synopsis of the British Diatomaceæ.

Mr. Comber said that Mr. Grove told him about these slides the last time he saw him, and although as a rule they contained just such species as might be expected to be found in any freshwater deposit here, there were two which seemed as if they were new, and of these the smaller one appeared to be a species of *Nitzschia*. Mr. Grove was of opinion that it would be of much greater advantage if Mr. Cooper would send some of the material over for examination, instead of mounting the diatoms himself, because the slides in question showed some room for improvement in this respect, and the work of identification was not facilitated by specimens mounted in that way.

Mr. Swift exhibited a microtome, which was made as an improvement upon the Cambridge Rocking Microtome, at the suggestion of Mr. R. Smith, who had experienced some difficulty in cutting sections with the original form, especially of substances of unequal density. The chief feature was that it was here possible to fix the razor obliquely, and to vary its angle as might be found best suited to the substance it was desired to cut. It was also possible with this machine to cut sections of specimens imbedded in celloidin in spirit, and an arrangement was also provided by which they could cut sections of specimens frozen by ether.

Mr. Swift also exhibited an improved form of his firm's new mechanical stage, in which the milled heads were both on the same side, as suggested by Mr. Karop; the stage had also a greater lateral motion than in the previous forms, viz., a motion of 2 in.

Mr. R. Smith said he had found by experiment that it was of some advantage to be able to vary the angle of the razor according to the substance it was desired to cut, and this alteration in the rocking microtome was accordingly suggested.

Mr. E. M. Nelson said he had seen this beautiful stage exhibited by Mr. Swift, and thought it a very great improvement upon many in use. It was a very bold design, and there could be no question as to the advantage to be derived, in many cases, by the great length through which it allowed a slide to traverse. He was sure that practical microscopists would regard this as a most valuable invention.

The President said, with regard to the microtome, the way in which these improvements had been carried out was certainly most ingenious, and it was no doubt a very useful addition to be able to cut sections of things imbedded in celloidin. The method of tilting the razor was very ingeniously contrived, but whether it would prove of ultimate value remained to be seen. He had himself, some time ago, made experiments as to the usefulness of tilting the razor in this way, but he rather came to the conclusion that it was, after all, not of great advantage. With regard to the mechanical stage, he was most struck by the feature which Mr. Nelson had alluded to, because he felt very strongly the great advantage of having such a large traversing motion, especially where it was desired to examine a long series of sections.

---

Dr. Measures exhibited and described a new mechanical stage, which had recently been sent over by Messrs. Zeiss. It would be found to be much better protected than the old one, and it would admit a much larger plate, like a cultivation plate. It was also fitted with verniers in both directions, reading to 1/10 millimetre, so that the position of anything could be registered without the use of any further finder. The arrangement was quite new, and the specimen exhibited was the first which had been sent to this country.

The President thought this was a beautiful stage; the only thing to which he should object was that the screw was rather inconveniently placed, but no doubt some slight modification would enable this to be readily got over. This stage he was glad to see also gave a very large range of movement.

---

Prof. Bell read a letter received from Mr. Oliver Collet, resident in Ceylon, offering to send over any objects of Microscopical interest from that island which might be in request by any of the Fellows of the Society. He requested that Mr. Collet should be communicated with direct by any of the Fellows to whom he was likely to be of service.

---

Dr. W. Aldren Turner gave an interesting lantern demonstration illustrating some of the results which had been obtained by staining the elements of the central nervous system. The various processes of

staining were resorted to for two purposes—firstly, to aid in the investigation of the structure in its normal conditions, and, secondly, to determine what changes had taken place in such structure under diseased conditions; many of the methods in use being employed for both these purposes. Putting aside from present consideration the old-fashioned but extremely good methods of staining with carmine, picrocarmine, logwood, &c., as being now little used alone in physiological investigations, reference was made to the various anilin stains, all kinds of which had been tried with varying success. One of the best known and most serviceable of these was Bevan Lewis' anilin-blue-black method, in which fresh sections were placed in a .25 per cent. aqueous solution of the stain, and afterwards washed and developed. Excellent results were obtained by this process, of which a good example was shown under one of the Microscopes upon the table. Weigert's method differed entirely from this, and by its means many very important pathological facts had been brought out. It might briefly be described as hardening by a solution of potassium bichromate, and staining by a solution of hæmatoxylin, afterwards being washed in water and treated with ferricyanide of potassium and borax. For human neuro-pathology this still held the field, although for experimental work it had been largely replaced by Marchi's method, where osmic acid was employed in conjunction with the potassium bichromate.

Pal's modification of Weigert's method was, however, mostly used: in this, after hardening and staining, the sections were treated with permanganate of potash, and then bleached with a solution of potassium sulphite and oxalic acid. Its value depended upon the staining reaction of the medullated sheath, only the medullated fibres and not the cells being permanently stained—the chief principle to be borne in mind whilst working with this method being the complete saturation of the tissue with the bichromate of potash. In illustration of the results obtained by this method a series of sections so treated were shown upon the screen by the projection Microscope: (1) Section of normal spinal cord of monkey; (2) Section of same showing degeneration, the diseased portion remaining unstained; (3) Section of human foetal spinal cord; (4) Section of medulla oblongata of monkey, &c. These methods of investigation showed the central nervous system to be built up of nerve-cells and their processes, the nerve-fibres, and the binding substance or neuroglia; previous methods had shown the nerve-cells and fibres more or less well, but until quite recently all had failed to show the extraordinary formation of cell processes. This recent method was the osmium-silver bichromate, or Golgi's method, originally described by Golgi in 1880, although not much known generally until 1889, when Ramon-y-Cajal of Barcelona used it, and Kölliker employed it very largely and with great success. Since that time it had been much used upon the Continent, but had been only adopted in England during recent years. The process itself was simple, but somewhat expensive and uncertain. The material was first hardened in a solution of bichromate of potash and osmic acid, and then put into a solution of silver nitrate; after being washed in water, the sections were dehydrated by alcohol, and mounted in Canada balsam without a cover-glass. The principle of this method seemed to be the formation of a bichromate of osmium

and silver, which either stained or was deposited upon the nerve-cells and fibres. Personally, he thought it was deposited, but it was worth noting that it was of little use in staining nerve-fibres already medullated, the tissue most suitable being embryonic and fœtal. In illustration of the value of this method a number of slides were shown by the lantern, as examples of the effects of the treatment upon cerebellum, cerebral cortex, &c., of newly-born kittens. Examples were also shown of cells without axis cylinder process, nerve-cells of the second type, and nerve fibres of the spinal cord, showing that they give off branches, and sections of brain and anterior portions of spinal cord of monkey. Dr. Turner, in explaining the value of the features of structure made apparent by this method of staining, pointed out that it seemed clearly demonstrated that the nerve-cells were of two types, in the first of which the axis cylinder process became the axis cylinder of the nerve fibre; and, in the second type, the axis cylinder process broke up and came in contact with other similar processes. The structure of the cell itself was obscured, but the nerves proceeding from it were shown with remarkable clearness, black and sharply defined, upon the screen. The protoplasmic processes were seen to be of two kinds, smooth and mossy, there being evidence that they conducted towards the cells. The axis cylinder processes could be very distinctly traced, giving off collaterals *en route*; these were often several feet in length, and ended in a terminal arborization, or end tuft, very beautifully shown on the slide exhibited.

Dr. Turner concluded by pointing out the great physiological principle which was determined by this method, viz. that the nerve-cell with its processes formed a unit, and that these units transmitted impressions, not by anastomoses or continuity of tissue, but merely by contiguity or contact of adjacent nerve cells and end-tufts, or of adjacent terminations. This principle appeared to hold throughout the central nervous apparatus, whether viewed in connection with centripetal tracts or with the great efferent projection system.

Mr. G. C. Karop thought the most interesting point of all, in connection with the sections exhibited, seemed to be the demonstration of the want of anastomosing in these fibres. It was customary to suppose that they did anastomose, and if it could be shown that they did not, it was clear that a great many things in connection with the subject of the nervous system would have to be re-cast.

Prof. Bell said he was particularly anxious that the Society should hear these things at first hand, and he had therefore asked Dr. Turner to come down and give them this very interesting demonstration. As regarded Golgi's method, he was at first much surprised to find that it had only been used in England comparatively recently, because there had been frequent references to Golgi's methods in their Journal for a long time; but then he remembered that the modern specialist, as a rule, read very little beyond the proof-sheets of his own productions, and the polemical books that dealt with his observations. They knew, however, that elsewhere these processes were adopted, and that Prof. Retzius turned out, regularly, examples of stained sections of the central nervous system of what they called the lower animals. They were sometimes asked, "What was the use of a Microscopical Society?" and it seemed



to him that one answer at least to the question was found in the fact that, if it were not for the existence of a large body of persons who were interested in "methods," histologists would not be able to do as much in the way of investigation as they now found to be possible. They were very much obliged to Dr. Turner for coming to the meeting that evening, and showing them not only what the results of these processes were, but how they bore on those physiological problems which presented themselves for solution. They might rest assured that those who went on improving their methods would continue to be materially assisting the physiologists in their investigations.

The President, in proposing a hearty vote of thanks to Dr. Turner for his very interesting demonstration, expressed the pleasure which it had given to those present to be made acquainted with the results attained by these staining processes, and especially by Golgi's method, which was one of the most valuable of all. He was himself much surprised to hear that English physiologists had only made use of it so recently, because it was certainly a process which gave them a knowledge of structure which was in the highest degree useful and valuable.

**Mr. E. M. Nelson**, who was warmly congratulated by the President upon his reappearance amongst the Fellows of the Society after his recent serious illness, explained, by means of blackboard diagrams, a simple method of measuring the refractive indices of media.

He also described a new modification of the reflecting camera lucida, by means of which the advantages of Dr. Beale's neutral tint reflector were secured, without its corresponding disadvantage of lateral inversion.

He also called attention to a very interesting little portable Microscope by Zentmayer, in the possession of Mr. Rousselet, and to a slide of karyokinesis of the lily, sent to him by Dr. Marriot of Salisbury, shown under a Microscope in the room.

The President was sure that anything which simplified or facilitated the use of a simple camera lucida was sure to be welcomed by those who were in the habit of making microscopical drawings. Personally, he was inclined to prefer to make drawings by using a piece of glass, ruled in squares, and drawing what he saw through this upon paper similarly ruled in squares; but where it was desired to draw objects rapidly, the possession of a simple camera lucida which did not require the head to be kept absolutely steady was a great advantage; and if the lateral inversion of the image could be got rid of and the object could be drawn as it appeared upon the stage, a very useful end had been attained. Anything in this direction which facilitated the process of delineating objects under the Microscope could not fail to be extremely useful.

The following Instruments, Objects, &c., were exhibited:—

The Society:—Mr. A. W. Cooper's Slides.

Dr. Measures:—A new Stage by Messrs. Zeiss.

Mr. E. M. Nelson:—A new Camera Lucida; Zentmayer's Portable Microscope; Slide showing Karyokinesis of Lily; Photomicrographs.

Mr. C. F. Rousselet :—Mounted Rotifers (*Synchaeta tremula*).

Messrs. Swift :—Improved form of Microtome; New Mechanical Stage.

Dr. W. A. Turner :—Slides illustrating his Demonstration—Human Cerebral Cortex stained by the Anilin-blue-black Method of Bevan Lewis; Cerebral Cortex and Medulla oblongata of a young Mammal stained with Golgi's Osmium-silver Method.

---

New Fellows :—The following were elected *Ordinary* Fellows :—Messrs. Charles Bailey, Horace Alonzo Bishop, Cecil Cooke Duncan, Dr. Max A. Goldstein, Dr. Robert Nesbit Howard, and Messrs. Alfred Letherby and Henry Morgan Lloyd.

INDEX OF NEW BIOLOGICAL TERMS, OR OLD TERMS WITH  
NEW MEANINGS, RECORDED IN THIS VOLUME.

a. ZOOLOGY.

- |   |   |
|---|---|
| Allantoidean trophoblast, Hubrecht, A. A. W., 321 | Omphaloidean trophoblast, Hubrecht, A. A. W., 321 |
| Anthoblasts, Bourne, G. C., 458                   | Pansporoblast, Gurley, R. R., 465                 |
| Anthocaulus, Bourne, G. C., 458                   | Parameres, Escherich, K., 674                     |
| Anthocormus, Bourne, G. C., 458                   | Pericornual nuclei, Gurley, R. R., 465            |
| Anthocyathus, Bourne, G. C., 458                  | Phænocytes, Gurley, R. R., 465                    |
| Bryozoite, Prouho, H., 183                        | Pharyngostome, Oswald, A., 328                    |
| Capsulated index, Gurley, R. R., 465              | Photesthetic, Whitman, C. O., 63                  |
| Choneostomata, Brady, G. S., 169                  | Photoptic, Nagel, W. A., 441                      |
| Cryptocytes, Gurley, R. R., 465                   | Photoskioptic, Nagel, W. A., 441                  |
| Disdiaklast, Knoll, P., 49                        | Pre-antennary organ, Janet, C., 334               |
| Ectadenia, Escherich, K., 674                     | Pseudo-faceted eye, Adensamer, T., 335            |
| Gastrostome, Oswald, A., 328                      | Rhynchodæum, Oswald, A., 328                      |
| Hypermetamorphoses, Perrier, E., 52               | Rhynchostome, Oswald, A., 328                     |
| Hypnodia, Künckel d'Herculais, J., 334            | Skioptic, Nagel, W. A., 441                       |
| Hypnotheca, Künckel d'Herculais, J., 334          | Sporoplasm, Gurley, R. R., 465                    |
| Ikonoptic, Nagel, W. A., 441                      | Synphagocytes, Salensky, W., 331                  |
| Nanism, Varigny, H. de, 670                       | Thymin, Kossel, A., and Neumann, A., 552          |
| Necrophagocytes, Salensky, W., 331                |   |

β. BOTANY.

- |  |  |
|--|--|
| Archenema, Macmillan, C., 481          | Metanema, Macmillan, C., 481             |
| Asciadiacæ, Macfarlane, J. M., 364     | Nucleo-centrosome, Karsten, G., 360      |
| Barymorphosis, Sachs, J., 591          | Paramannan, Gilson, E., 216              |
| Cane-spume, Cobb, N. A., 723           | Parathermotropic, Macfarlane, J. M., 593 |
| Chamber-fluid, Crato, E., 359          | Perimedullary Zone, Flot, L., 361        |
| Columel (sens. nov.), Jaccard, P., 708 | Photomorphosis, Sachs, J., 591           |
| Elaiosphere, Lidforss, B., 704         | Photo-syntax, Barnes, C. R., 371         |
| Euacranthic, Schumann, K., 472         | Prehaustorium, Peirce, G. T., 480        |
| Eu-Floridæ, Johnson, T., 599           | Protochlorophyll, Monteverde, N., 702    |
| Fatigue-substance, Reinitzer, F., 361  | Pseudacranthic, Schumann, K., 472        |
| Hemicellulose, Gilson, E., 216         | Pseud-epiphyte, Went, F. A. F. C., 588   |
| Hemi-epiphyte, Went, F. A. F. C., 589  | Pseudo-inulin, Tanret, C., 217           |
| Internal Pericycle, Flot, L., 219      | Pseudo-vivipary, Potonié, H., 477        |
| Inulenin, Tanret, C., 217              | Species Sorores, Schröter, J., 603       |
| Karyoid, Palla, E., 717                | Spermatange, Johnson, T., 599            |
| Kinoplasm, Strasburger, E., 581        | Symplast, Klemm, P., 376                 |
| Leucocidine, Van der Velde, H., 732    | Thelocarpeæ, Zukal, H., 93               |
| Mechanomorphosis, Sachs, J., 591       | Trophoplasm, Strasburger, E., 581        |
| Medicagophyll, Etard, A., 702          | Water-parasite, Peirce, G. T., 83        |





## INDEX.

## A

- Abbe Camera Lucida, Watson's Aluminium, 286
- Abbott, A. C., Secondary Foci in Experimental Diphtheria, 610
- Abdomen of Lampyridæ, Cantharidæ, and Malachiidæ, Comparative Morphology of, 673
- Abdominal Vein in Amphibia, Development, 665
- Abel, R., Isolating Bacillus of Diphtheria from Toys, 128
- Viability Period of Diphtheria, 248
- Aberation, Chromatic, of Lenses, 116
- Abies pectinata*, Resin-canals in, 585
- Abscess of Jaw, Amœbæ in, 72
- of Lung and Liver, Protozoa in, 700
- Absorption-spectrum of Chlorophyll, 701
- Aby, F. S., Development of Hypophysis Cerebri in Domestic Cat, 35
- Acalyphæa*, Anatomy, 78
- Acanthocephala, 65
- Acari, Present State of Knowledge, 18
- Acer rubrum*, Embryo-sac, 367
- Acetic Acid Bacteria, 242, 384
- — -forming Blastomycete, 236
- Achromatic Object-glasses, Method of Increasing the N.A. of Old, 286, 413, 518
- Achromatium oxaliferum*, 239
- Acid Production by Bacteria, 384
- Acids, Organic, Formation and Decomposition, 594
- Acosta, E., Bacteriological Technique, 524
- Acqua, C., Formation of Starch in *Pelargonium zonale*, 372
- Germination of Pollen of *Vinca major*, 84
- Acrididæ, Diptera Parasitic on, 560
- New Gregarine in Algerian, 212
- Oviposition, 560
- Acrosiphonia*, 484
- Actinococcus*, 376
- Actinomyces*, 604
- *Gruberi*, sp. n., 725
- Actinomycosis and Phagocytosis, 611
- Actinosphærium*, Plastogamy, 576
- Adder, Development of Teeth in, 435
- Adensamer, T., Eyes of *Scutigera coleoptrata*, 335
- Adjustment, Leitz's Micrometer Screw, 109
- Aerobic Bacteria, Formation of Sulphuretted Hydrogen and Mercaptan by, 607
- Aereboe, F., Influence of Light on Respiration, 713
- Africa, New Genera of Earthworms from Western Tropical, 569
- Oligochaeta of Eastern Tropical, 568
- Thelphusæ from Eastern, 567
- Afromendoncia*, Anatomy, 221
- Agar, Cultivating Anaerobes in, 630
- Rapid Method for making Nutrient, 750
- Urine, for Cultivating Diphtheria Bacillus, 128
- Agardh, J. G., New Genera of Algæ, 89, 483, 598
- Agave*, Spherocrystals, 704
- Ager, L. C., Peculiar Chromatogenic Bacillus, 503
- Air, Apparatus for Bacteriological Examination of, 280, 398, 629
- Filter, 747
- Micro-organisms, Duration of Incubation on Gelatin, 494
- 'Albatross,' Aleyonaria of, 351
- Hydroids of, 351
- Pantopoda of, 193
- Turbellaria of, 202
- Albumen, Egg-, Cultivation Medium for Micro-organisms, 268
- Micro-chemical Reaction of Vegetable, 644
- Potash, Bactericidal Properties of, 493
- Albuminates, Nutrient Media containing Alkali, 750
- Albuminoids, Composition of Vegetable, 217
- Albumum, Comparison of Duramen and, 219
- Alciopidæ, Auditory Organs of, 451
- Alcock, A., Deep-sea Invertebrates of Indian Ocean, 439
- Illustration of Indian Echinoderms, 689
- Alcohol, Influence on Disinfectants, 608

- Alcoholic Fermentation, Influence of Oxygen on, 594
- Aleyonaria* of 'Albatross,' 350
- *Stolonifera*, Revision, 690
- Alder-fruit, Sclerote in, 720
- Aleurites*, Extra-floral Nectaries of, 705
- Aleurone-layer in Seed of Grasses, 78
- Alexocytes, 243
- Algæ. *See* CONTENTS, xxv
- Apparatus for Pure Cultivation, 744
- Filiform, Anatomy of Cell, 74
- Fixation of Free Nitrogen by, 592
- Microscopical Preparations of, 277
- Parasites on, 87
- Symbiosis with Cycas, 478
- Algerian Acrididæ, New Gregarine in, 212
- Alimentary Canal of Orthoptera, 445, 560
- Alkali Albuminates, Nutrient Media containing, 750
- Alkaline Reaction of Aquatic Plants, 372
- Alkaloids, Localization, 703
- Allen, E. J., Histology of Nervous System of Embryonic Lobster, 563
- Alpine Flowers, Bright Colour, 705
- Rotifers, 67
- Altman's Bioplasts, 326
- Aluminium Abbe Camera Lucida, 286
- Ramsden Screw Micrometer, 286
- Amann, J., Improvements and Additions to the Microscope Stand, 392
- Koristka Semi-Apochromatic 1/15, 737
- Amboyna, Bay of, Cephalopoda, 534
- — Echinoderms, 349
- Amelung, E., Etiolation, 477
- Amentiferæ, Embryology, 707
- America, North, Myriopoda of, 447
- American Crayfishes, Leech-like Parasites of, 343
- Amia*, Epiphysis, 546
- *calva*, Development of the Kidneys, 546
- Amicis, G. A. De. *See* De Amicis
- Amm, A., Intramolecular Respiration, 87
- Ammoniacal Fermentation of Earth, 244
- Amniotic, Sero-, Connection and Fœtal Membranes of Chick, 663
- Amœba coli*, 212
- Amœba-enteritis, 696
- Amœbæ and their Cultivation, 354
- Classification, 694
- in Abscess of Jaw, 72
- Life, 694
- Amœbocytes in *Micronereis variegata*, 199
- Amphibia, Development of Abdominal Vein, 665
- — — Bulbus Cordis, 664
- — — Hypophysis and Saccus vasculosus, 665
- Amphictenidæ, Habits, 567
- Amphiozus*, Development, 549
- Amphiuma*, Development of Excretory System, 435
- Amyloid, Vegetable, 76
- Anaerobes, Cultivating in Agar, 630
- Anaerobes of the Soil. Influence of Physico-Chemical Agents on some Pathogenic, 387
- Plate Cultivations of, 270
- Anaerobic Bacteria, Cultivation Media for, 127
- — Examining Water for, 527
- Cultivations, Apparatus for, 327, 628
- Micro-organisms, 493
- Anatomy of Phanerogams. *See* CONTENTS, xix
- Ancestral Rudiments, Significance in Embryonic Development, 433
- Ancyclus*, Gonads, 668
- Investigation, 402
- *lacustris* and *A. fluviatilis*, Anatomy and Physiology, 329
- Anderegg, E., Alternation of Generations in Insects, 558
- Andouard, A., Development of *Arachis*, 83
- André, E., Anatomy and Physiology of *Ancyclus lacustris* and *A. fluviatilis*, 329
- Investigation of *Ancyclus*, 402
- Andriezen, W. L., Modification of Golgi's Method for Human Brain, 533
- Androconia of Lepidoptera, 186
- Anilin Dyes, Staining Tubercle Bacilli in Sublimate Solutions of, 276
- Animals, Hæmatozoa in, 358
- Preservative Fluid for, 277
- Anisotropic Layers, Relations of Isotropic to, in Striped Muscles, 437
- Annelida. *See* CONTENTS, xiv
- Annulus of Sporangium of Ferns, 374
- Antennæ of Cyclopidæ, 58
- Antennary Nerves in Ants, 334
- Sensory Organs of Insects, 185
- Anthocyan, Physiological Function, 228
- Anthrax in Rabbit, and its Lessons, 501
- in Rats, 246
- Spores, Experiments as to Vitality in Earth and Water, 527
- — Nuclei, 385
- — Staining Nuclei of, 406
- Antibacterial Action of Oxycinchaseptol, 268
- Antiseptic, Dithion, a New, 281
- Ants, Antennary Nerves and Chordotonal Organs in, 334
- Glandular System, 444
- Nematodes of Pharyngeal Glands, 64
- Production of Sound, 334
- Worker, Evolution, 332
- Aortic Arches in Chelonia, Development, 38
- Apáthy, S., Conducting Element in Muscle-fibres of *Ascaris*, 570
- Apetalæ, Secondary Wood of, 220
- Aphanocheate globosa*, 2
- var. *depressa*, 2
- Aphanothece saxicola* var. *sphærica*, 17
- var. *violacea*, 17

- Apios tuberosa*, Tubers of, 83  
 Apochromatic, Semi-, 1/15 Objective, 737  
 Apocynaceæ, Branching, 82  
*Apolemia uearia*, Structure of Tentacles of, 459  
 Apophyse of Fruit-scales of *Pinus*, Navel of, 364  
 Appellöf, A., Bilateral Hectocotylyzation in *Eledone cirrhosa*, 46  
 — Cephalopoda of North Sea, 45  
 — Shells of *Sepia*, *Spirula*, and *Nautilus*, 553  
 Appendicularia, so-called Segmentation of Tail in, 442  
 Appendicularia, Vertebraion of Tail, 557  
 Apple-must, Fermenting, with Pure-bred Yeasts, 235  
 Apstein, C., Salpæ of Berlin Museum, 183  
*Apus*, The Genus, 60  
 Aquarium, Stage-, 121  
*Arachis*, Development, 83  
 — Root-tubercles, 707  
 Arachnida. See CONTENTS, xiii  
 Arborescent Liliaceæ, Root, 220  
 Archenema, 481  
 Archoplasm and Attraction Sphere, 666  
*Areca Catechu*, Rumination of Seeds, 706  
 Arens, —, Plate Cultivations of Anaerobes, 270  
 Aril, Pigment of, 469  
*Aristolochia*, Staminal Appendages, 80  
 Arloing, S., Diagnostic Value of Soluble Products of Microbe of Peripneumonia bovina, 248  
 — Experimental Production of Bovine Peripneumonia, 610  
 — Microbic Origin of Virulent Surgical Infection, 249  
 Arnould, J., New Curved Bacilli from Water, 503  
 Arrack, Microbiology and Manufacture of, 602  
 Arsenic, Fungi which feed on, 377  
 Arsonval, D', Influence of Cosmic Agents on the Development of Bacterial Cell, 503  
 — Influence of Electricity on Microbe-cell, 391  
 Artefacts, Production by certain Fixatives, 757  
*Artemia*, Parthenogenesis, 339  
 — *fertilis* from Great Salt Lake, 536  
*Arthrodesmus bifidus*, 9  
 — *controversus*, 9  
 — *convergens*, 9  
 Arthropoda. See CONTENTS, xi  
 Articulates, Derivation and Homologies of some, 442  
*Ascaris*, Conducting Element in Muscle-fibres of, 570  
 — Experiments with Ova of, 201  
 — *megaloccephala*, Spermatogenesis in, 63  
 — Muscular Cells of, 685  
*Ascidia virginea*, Variations in Dorsal Tubercle of, 557  
 Ascidian Embryos, Origin of Peribranchial Cavity in, 50  
 Ascidians of Minorca, 51  
 Ascospores, Cultivating, 127  
 Ascothoracida, 197  
 Aseptic Protozoa Cultures, 744  
 Asexual Reproduction in Freshwater Turbellaria, 685  
 — — of *Madrepora*, 457  
 Ash, Cancer produced by Bacteria, 243  
 Asiatic Cholera, Value of Bacteriological Diagnosis, 388  
 Askenasy, E., Australian Marine Algæ, 483  
 Asparagææ, Cladodes of, 472  
*Aspergillus* developing in Sulphate of Quinine, 380  
*Asterina gibbosa*, Organogeny, 206  
 Asteroidea, 689  
 — Hæmal and Water-vascular Systems of, 574  
 — of 'Travailleur' and 'Talisman' Expeditions, 205  
 Astroumoff, A., Flying Copepod, 681  
*Ataccia*, Anatomy, 362  
 Atkinson, G. F., Annulus of Sporangium of Ferns, 374  
 — Embryo of Ferns, 373  
 — Parasitic Fungi, 601  
 — Photographing Plate Cultivations, 263  
 — Symbiotic Fungus of Ophioglossaceæ, 94  
 Atlantic, North, Holothurians, 207  
 — Ocean, Bacterial Flora, 608  
*Atragene*, Swellings of Leaf-Stalk, 473  
 Attraction-sphere, Archoplasm and, 666  
 Auché, A., Red Cocco-bacillus of Sardine, 733  
 Auditory Organs of Aleioidæ, 451  
 Auer Incandescent Light, Comparison between Petroleum, Gas and, with respect to Photomicrography, 627  
 Auerbach, L., Spermatozoa of *Dytiscus*, 52  
 Aurivillius, C. W. S., Post-embryonic Development of Lepadidæ, 339  
 Australian Hydroids, 209  
 — Marine Algæ, 483  
 — Nematodes, 202  
 Autobasidiomycetes, Vascular Hyphæ, 724  
 Autotomy in Animal Kingdom, 438  
 Avetta, C., Cystoliths of *Coccinia*, 471  
 Axis-cylinders, Demonstrating, 275  
*Axolotl*, Maturation and Fertilization of Egg, 38
- B.
- Babès, V., On Acute Hepatic Degeneration due to Streptococci, 614  
 — The State and Modern Bacteriological Research, 491

- Bachmann, J., Sporangies of *Thamnidium elegans*, 600
- O., Manual of Microscopical Technique, 266
- Bacillar Diseases of Plants, 492
- Bacilli, Cholera, Action of some Sozoidol Preparations and of Tribromophenol-Bismuth on, 281
- — Growth on Potato, 128
- Leprosy and Tubercle, Simultaneous Double Stain for, 277
- Tubercle, Examining Street Dust for, 134
- — Mixed Infection from Pyogenic Cocci and, 248
- — New Method for Detecting in Phthi-sical Sputum, 402
- — Staining, 640
- — in Sublimate Solutions of Anilin Dyes, 276
- — Technique for Studying in Lung, 401
- Typhoid, Difference between *B. typhosus* and, 388
- Bacillus anthracis*, Conversion of Starch into Sugar by, 384
- Bacillus*, Capsule, of Ozaena, 100
- Cholera, and Tobacco, 499
- — *Vibrio* resembling, 247
- Composite Cilia of, 384
- Diphtheria, Effect of Citric Acid, 728
- — Isolating from Toys, 128
- — Urine-Agar for Cultivating, 128
- Bacillus hydrophilus fuscus*, Physiological Effect of Metabolic Products, 495
- Bacillus*, Influenza, Cultivating, 526
- — Demonstration, 640
- — Egg-yolk Medium for Cultivating, 269
- — Pfeiffer's, 100
- Bacillus lactis aerogenes*, Relations of Fried-laender's *Pneumobacillus* and Lactic Ferment with, 245
- *levans*, 500
- *mycoïdes* and Nitrification, 98
- Bacillus*, New Gas-forming, 387
- of Bubo Plague, 730
- of Frogs, Pathogenic, 730
- of Mouse-disease, 390
- Bacillus pyocyaneus*, Pathogenic Action on Human Beings, 613
- — Pigment-production of, in Symbiosis with other Organisms, 495
- Bacillus*, Red Cocco-, of Sardine, 389
- Tetanus, Cultivation, 630
- Tubercle, Influence of Natural Agents on Virulence, 726
- Bacillus typhi murium* and Caucasian Field Mice, 613
- Bacillus*, Typhoid, Characteristic Mobility, 388
- — Formalin as Test for, 268
- Bacillus typhosus*, Differences between *B. coli commune* and, 611
- Bacillus typhosus*, Differences between Typhoid Bacilli and, 388
- — in Drinking-Water, 99
- — Relations of Friedlaender's *Pneumo-bacillus* and of Lactic Ferment with, 245
- Bacteria, Acetic Acid, 242, 384
- Action of Light on, 241
- — of Nuclein Acid on, 607
- Aerobic, Formation of Sulphuretted Hydrogen and Mercaptan by, 607
- Anaerobic, Apparatus for Cultivating, 397
- — Cultivating Media for, 127
- — Examining Water for, 527
- Cancer of Ash produced by, 243
- Chromogenic Water-, 245
- Cilia of, New Method of Staining, 405
- Coli Group of, 499
- Colonies, Distribution in Esmarch's Roll Tubes, 529
- Demonstrating Sulphuretted Hydrogen generated by, 530
- Gas and Acid Production by, 384
- Gaseous Products of, 242
- Making and Preserving Specimens for Museum purposes, 531
- Morphology, 491
- Preparation of Nutrient Medium from Eggs, 399
- Resistance to Pressure combined with High Temperature, 97
- Respiration-figures on Mobile, 242
- Staining Flagella of, 640
- Symbiosis with *Cycas*, 478
- Thermogenous, 384
- Water-, Diagnosis, 136
- Bacterial Association, Influence, 726
- Flora of Atlantic Ocean, 608
- Poisons, Intracellular, 495
- Bactericidal Power, Leucocytes and, 492
- — of Blood, 98
- — of Body Juices, 729
- — of Dog's Blood, 610
- Properties of Potash-albumen, 493
- — of Vasogen, 387
- Bacteriological Diagnosis of Asiatic Cho-lera, 388
- Examination of Air, 280, 398, 629
- Microscope, 734
- Purposes, Heating Arrangement of Microscope for, 630
- Research, The State and, 491
- Technique, Hints, 264
- — Short Notes on, 524
- Bacteriology, Gedoelst's, for Veterinary Surgeons, 137
- Günther's, 137
- in Surgery, 608
- Kitt's, 137
- Manuals, 732
- of Plankton Expedition, 502
- — Teeth-pulp, 727
- Schenck's Manual, 502



- Bacterium coli commune*, Differences between *B. typhosus* and, 611  
 — — — in Drinking-water, 99  
 — — — in Living Blood, 500  
 — — — Testing Resistance to Drying, 528  
*Bacterium* of Lymph, New, 386  
*Bacterium Zopfi*, Action of Gravity on, 609  
 — — Growing and Examining, 526  
 Badcock, J., 510  
 Baer's, von, Law and Significance of Ancestral Rudiments in Embryonic Development, 433  
 Baker's Photographic Microscope, 417, 517  
*Balanoglossus*, Development, 573  
 — from New South Wales, 455  
 — Larva, 204  
 — Preserving Larvæ, 631  
*Balantidium viride*, 211  
 Bale, W. M., Australian Hydroids, 209  
 Ball, M. V., Essentials of Bacteriology, 503  
 Bambeke, C. Van, Median Groove of *Triton*, 324  
 Bangiaceæ, Systematic Position of, 599  
 Barbel, Muscle Degeneration from Presence of Myxosporidia, 72  
 Barley, Production of Saccharose in Germination of, 230  
 Barnes, C. R., Food of Green Plants, 371  
 Barnow, —, *Bacterium coli commune* in Living Blood, 500  
 Barton, B. W., Stichids and Tetrasporanges of *Dasya*, 376  
 Basle, Turbellaria-fauna of, 571  
 Bast-cells, Transverse Lamellation of Membrane, 216  
 Bastianelli, —, Structure of Malaria Parasites of Summer and Autumn Fevers, 700  
 Bataillon, E., Disease in Fresh Water, 726  
 — Growth of Blastoderm in Teleosteans, 40  
 — Karyokinetic Phenomena in Cells of Blastoderm of Teleosteans, 41  
 Bather, F. A., Silurian Crinoids, 68  
 Bay, C., Spore-forming *Saccharomyces*, 722  
 — J. C., Compass Plants, 713  
 — Infection Needle, 748  
*Bdella arenaria*, Anatomy, 57  
 Beach, S. A., Parasitic Fungi, 489  
 Beard, J., Development of Thymus, 436  
 Beaumont, W. I., Luccarnia of Port Erin, 460  
 Becker, J., Method for obtaining Hæmin Crystals, 273  
 Beck, C., 538  
 — R. & J., "Continental" Microscope, 616  
 — S., Bacteriological Examination of Water, 391  
 Beddard, F. E., New Earthworms from Western Tropical Africa, 569  
 — New or Little-known Oligochæta, 683  
 — Oligochæta of E. Tropical Africa, 568  
 Beddard, F. E., South American Tubificidae, 200  
 Bedot, M., The late H. Fol, 395  
 Beecher, C. E., Appendages of Pygidium of *Triarthrus*, 335  
 — Thoracic Legs of *Triarthrus*, 198  
 Bees and Dead Carcasses, 441  
 — Fertile Workers among, 674  
 Beetles, Male Reproductive Organs of, 673  
 Behrendsen's Steam Sterilizer, 266  
 Behrens, H., Micro-chemistry, 522  
 — J., Pollination of Hop, 710  
 Bell, F. J., 148, 282, 284, 413, 418, 537, 539, 540  
 — Echinoderms of Eastern Seas, 688  
 — Thelphusæ from Eastern Africa, 567  
 Belzung, E., Calcium Oxalate in Solution, 704  
 — Chlorophyll-grains in Seeds and Seedlings, 584  
 — Spherocrystals of *Euphorbia*, 76  
 Bemmelen, J. F. van, Development of Gill-pouches and Aortic Arches in *Chelonia*, 38  
 Beneden, P. J. van, the late, 118  
 Benecke, F., Rapidity of Growth, 369  
 Bèneke, —, Collection of Microscopic Preparations, 760  
 — Puncture Cultivations, 124  
 Bennett, A. W., 539, 763  
*Bennettiles*, Fruit, 363  
 Benson, M., Embryology of Amentiferæ, 707  
 Beranek, E., Auditory Organs of Alciopidae, 451  
*Berberis*, Movements of Stamens, 712  
 Bergendal, D., *Polypostia similis*, 345  
 Bergh, R. S., Cell and Animal Tissues, 549  
 — Dorididæ, 46, 179  
 — Genus *Gastropteron*, 180  
 — Germinal Area of *Mysis*, 57  
 — New Polycepad, 182  
 — Shifting of Germinal Streak in *Gammarus*, 195  
 Berkefeld Filter, 267  
 Berkeley, H. J., Investigating Histology of Vertebrate Liver, 128  
 — Modification of Golgi Silver Stain, 755  
 — Nerve-supply of Cardiac Ventricles, 755  
 Berlese, A. N., Parasitic Fungi, 722  
 Berlin Museum, Salpæ of, 183  
 Bernard, H. M., Chernetidæ, 56  
 — Endosternite of *Scorpio*, 192  
 — Lateral Eyes in Galeodidæ, 447  
 — Relations of Isotropic to Anisotropic Layers in Striped Muscles, 437  
 — Stigmata of Arachnida, 55  
 — Systematic Position of Trilobites, 562  
 — Vestigial Stigmata in Arachnida, 561  
 Bertram, A., Sarcosporidia of Gecko, Sheep, and Swine, 72  
 Bescherelle, E., New Genera of Musci, 231

- Bethe, A., Function of Equilibration, 666  
 Beyerinck, M. W., Action of Gravity on  
*Bacterium Zoppi*, 609  
 — Demonstrating Protozoa and Spirilla  
 in Drinking-water, 274  
 — Filaments of Tubercles of Papilionaceæ,  
 609  
 — Respiration Figures of Mobile Bacte-  
 ria, 242  
 — *Schizosaccharomyces octosporus*, 602  
 Bibliography of Vertebrate Embryology,  
 325  
 Bielajew, W., Karyokinesis in Pollen-  
 mother-cells of *Larix*, 74  
 Bignami, —, Structure of Malaria Para-  
 sites of Summer and Autumn Fevers,  
 700  
 Bile-duct of Rabbits, Development of *Coc-  
 cidium oviforme* in, 355  
 Bilfinger, L., Rotifera of Wurtemberg, 456  
 Binocular Microscope, Ross, 736  
 Biochemic Investigations, Culture Media  
 for, 124  
 Bioplasts, Altmann's, 326  
 Bipinnariæ from English Channel, 207  
 Birds, Ganglion Ridges in Head, 37  
 — Hæmatozoa of, 357  
 — Relations of Notochord and Hypophy-  
 sis in, 544  
 Biro, —, Fungi of *Favus*, 604  
 Bismuth, Tribromophenol, Action on Cho-  
 lera Bacilli, 281  
 Blachstein, H., Pathogenic Properties of  
 Water Microbes, 385  
 Black Forest, Algæ of, 89  
 Bladder, Development, 174  
 Blanc, H., Fecundation of Egg of Trout,  
 324  
 — Fertilization of Trout's Ovum, 435  
 — Preparation of Eggs of Trout, 272  
 Blanchard, R., Leeches of Iberian Penin-  
 sula, 343  
 — Notes on Hirudinea, 344  
 Blasdale, W. C., Parasitic Fungi, 488  
 Blastoderm, Growth in Teleosteans, 40  
 — of Teleosteans, Karyokinetic Pheno-  
 mena in Cells of, 41  
 Blastomycete, Acetic Acid-forming, 236  
 Bleaching Animals and Sections fixed  
 with Osmic Mixtures, 534  
 Bleeding of Plants, Internal, 87  
 Blenkins, G. E., The late, 742  
 Blochmann, F., *Dimorpha nutans*, 463  
 — Nuclear Division in *Euglena*, 577  
 — Studies on Protozoa, 210  
 Blood, Atlas of Clinical Microscopy of,  
 136  
 — Bactericidal Power of, 98  
 — *Bacterium coli commune* in Living,  
 500  
 — corpuscles, New Method of Separating  
 White from Red by Hæmatokrit, 278  
 — Corpuscles, Rapid Staining, 756  
 Blood, Defensive Ejection, 445  
 — Dog's, Bactericidal Power and Richness  
 in Leucocytes, 610  
 — of Cancerous Persons, Living Parasites  
 in, 580  
 — of *Necturus* and *Cryptobranchius*, Invest-  
 igation, 402  
 — of Vertebrates, Endoglobular Parasites  
 of, 578  
 — Origin, 175  
 — Quick Double-staining Method for  
 Examination of, 639  
 — Serum as Diagnostic Cultivation Me-  
 dium for Cholera Vibrio, 269  
 — — Obtaining Germ-free, 400  
 — Staining Micro-organisms in, 757  
 Blum, F., Formaldehyde for Hardening  
 and Preserving, 277  
 — J., Formol as a Preservative Fluid, 758  
 Boas, J. E. V., Stigmata of Larva of *Me-  
 lolontha*, 54  
 Bochiechio, N., *Lactomyces inflans casei-  
 grana*, 603  
 Boehm, J., Capillarity and Ascent of Sap,  
 87  
 Bohland, —, Collecting and Preserving  
 Urinary Sediment, 643  
 Bokorny, T., Aggregation of Protoplasm,  
 359  
 — Purification of Streams by Chloro-  
 phyllous Plants, 714  
 Bolley, H. L., Root-tubercles of Legumi-  
 nose, 707  
 Bolsius, H., Efferent Canal of Glossipho-  
 nidæ, 683  
 Bombycine Moths, Life-history, 187  
*Bombyx*, Muscular Action in, 52  
 — *Mori*, Spermatogenesis, 187  
 Bones in *Limulus*, Structures resembling  
 Dermal, 448  
 Bonnier, G., Nutrition of Green Parasites,  
 711  
 — Vegetable Heat, 372  
 Borchardt, M., Demonstration of Influenza  
 Bacillus, 640  
 Bordas, —, Male Genital Apparatus of  
 Hymenoptera, 53  
 — Poison-Apparatus of Hymenoptera,  
 445  
 — Salivary Glands of Crabronidæ, 334  
 — — of Hymenoptera, 189  
 — — of Ichneumonidæ, 445  
 — Tracheal System of Larval Hymeno-  
 ptera, 334  
 Borden, W. C., Stereoscopic Photomicro-  
 graphy, 262, 413, 537  
 Bordet, J., Irritability of Spermatozoids of  
 Fucaceæ, 599  
 Bordoni-Uffreduzzi's Manual of Bacterio-  
 logy, 732  
 Borgert, A., New *Dolium*, 51  
 Born, G., Experimental Embryology, 34  
 — New Section-stretcher, 132

- Born, G., Newt, Ova, 631  
 — Structure of Nucleus in Ovarian Ovum of *Triton*, 545  
 Borraginacæ, Branching, 82  
 Borrel, A., Technique for Studying Tubercle Bacilli in Lung, 401  
 Bos, R., Breeding in and in, 172  
 Bosanquet, W. C., Gregarine of *Lunbricus herculeus*, 577  
 Botanical Microtechnique, 523, 632  
*Bothriocephalus*, Cystic Worms in German Fishes, 346  
 Bouillon Cultivations and Bujwid Reaction, 525  
 — Growth of *Streptococcus longus* in, 611  
 Boulanger, E., New Genera of Fungi, 378  
 Bourne, A. G., Anatomy and Development of some Earthworms, 569  
 — *Moniligaster*, 569  
 — G. C., *Heliopora cærulea*, 690  
 — Post-embryonic Development of *Fungia*, 458  
 Bourquelot, E., Ferment of Fungi, 377  
 — Physiology of *Penicillium Duclauxi*, 94  
 Boutan, L., Nervous System of *Nerita* and *Navicella*, 181  
 Bouvier, E. L., Conversion of Pagurinae into Lithodinae, 678  
 — Galatheidae, 565  
 — Lomisinae, 566  
 Bovine Peripneumonia, Experimental Production of, 610  
 Bower, F. O., Sporophyte of Equisetinae and Lycopodinae, 88  
 — Structure of *Buxbaumia*, 232  
 — — of *Lepidostrobos*, 88  
 Bowerbank's British Sponges, Generic Nomenclature of, 576  
 Box, Male Flowers of, 587  
 Boyce, R., Action of Gravity on *Bacterium Zopfii*, 609  
 — Growing and Examining *Bacterium Zopfii*, 526  
 Brady, G. S., *Fucitrogus Rhodymenia*, a Gall-producing Copepod, 168, 283  
 Braem, F., Buds of Hydroids, 691  
 — Development of *Ophryotrocha*, 340  
 — Experimental Embryology, 661  
 — Genus *Apus*, 60  
 Braemer, L., Localization of Active Principles of Cucurbitaceæ, 361  
 Brain, Human, Modification of Golgi's Method for, 533  
 — Method of Preparing Fresh Sections, 271  
 — Sections, Microtome for, 636  
 Braithwaite, R., 151  
 — British Moss-Flora, 374  
 Bramwell, B., Collecting and Preserving Urinary Sediment, 643  
 Branchiate Pulmonates, 670  
 Branching of Borraginacæ and Apocynacæ, 82  
 — Vegetative, 364  
*Branchipus*, Ovum, 59  
 Brand, F., Leaves of Nymphæacæ, 366  
 Brauer, A., Development of Scorpion, 677  
 — Ovum of *Branchipus*, 59  
 — Parthenogenesis of *Artemia*, 339  
 — Spermatogenesis in *Ascaris megalocephala*, 63  
 Braun, M., Cystic Worms of *Bothriocephalus* in German Fishes, 346  
 — Life-History of Holostomida, 454  
 — New Human Liver Fluke, 454  
 Bréal, E., Assimilation of Nitrogen by Plants, 478  
 Breeding in and in, 172  
 Brefeld's Mesomycetes, 719  
 Brick, C., Parasitic Fungi, 489  
 British Columbia, Natural History, 328  
 — Fishes, Ova and Larvæ, 665  
 — Freshwater Algæ, New, 1  
 — Lichens, 488  
 — Moss-Flora, 374  
 — Museum, British Lichens, 488  
 — Sponges, Generic Nomenclature of  
 Bowerbank's, 576  
 — Tunicata, 50  
 Britton, E. G., *Physcomitrium*, 596  
 Brizi, U., Fossil Bryophytes, 597  
 Brodhun, Lummer-, Prism Pair, Colorimeter with, 740  
 Brooding Habits of *Octopus Diqueti*, 328  
 Brown, G. W., New Substage, 252  
 — J. W., A Home-made Microscope, 414  
 Bruce, D., Ætiology of Malta Fever, 500  
 Bruhne, K., Parasitic Fungi, 601  
 Brunc, J., New Genera of Diatoms, 240  
 Bruns, E., *Polysaccum*, 490  
 Bruyant, C., Stridulating Aquatic Hemipteron, 191  
 Bryce, D., New Rotifers, 67  
 Bryophytes, Fossil, 597  
 Bryozoa. See CONTENTS, xi  
 Bubo Plague, Bacillus of, 730  
 Buccal Apparatus of Cirripedia, 196  
 Buchanan, F., Polynoid with Branchiæ, 199  
 Buchner, H., Influence of Light on Bacteria, Self-purification of Rivers, 102  
 Buds of Woody Plants, Opening, 222  
 Bürger, O., Developmental History of Nemertines, 344  
 Büsgen, M., Polymorphism of *Cladotrix*, 726  
 Bütschli, O. v. Microscopic Foam and Protoplasm, 437  
 — Structure of Starch Grains, 217  
 Bujwid Reaction and Bouillon Cultivations, 525  
 Bulbils of *Chatonema*, 599  
 — of Dioscoreacæ, 83  
 Bulbs of *Cystopteris bulbifera*, 595

- Bulbus Cordis, Development in Amphibians and Reptiles, 664
- Bumpus, H. C., Median Eye of Adult Crustacea, 449
- Bunge, R., Staining Flagella of Bacteria, 640
- Bunting, M., Origin of Sex-Cells in *Hydractinia*, 576
- Burri, R., Bacteriological Investigations to discover characteristics of species, description of new Bacteria from the Rhine, 102
- On a new Bacillus like that of Splenic Fever from South American Fodder, 614
- Buscalioni, L. N., Cuticle of Seeds of Papilionaceæ, 81
- Embryology of *Veronica hederæfolia*, 225
- Embryo-sac of *Plantago*, 589
- Busse, O., Parasitic Cell-inclusions and their Cultivations, 748
- Butomaceæ, Leaf, 366
- Butschinsky, P., Development of *Gebia littoralis*, 564
- Embryology of *Gebia littoralis*, 631
- Butter, Micro-organisms of Rancid, 496
- Butterflies, Reproduction in, 559
- Seasonal Dimorphism and Polymorphism in Japanese, 444
- Buxbaumia*, Structure, 232
- C.
- Cabombaceæ, Morphology, 588
- Cæspitose Plants, Anatomical Characters, 79
- Calcium Oxalate in Solution, 704
- Phosphate, Excretions, 77
- Calcutta, Microscopical Society, 264
- Californian Eudrilidæ, 342
- Callinhabdos*, 691
- Calyceæ, 94
- Cambarus*, Blind, from Florida, 450
- Cambridge, Microscopic Preparations at, 760
- Camera Lucida, Drawing imperfectly visible details with, 408
- — Koristka's, 623
- — Nelson's, 771
- — Watson's Aluminium, 286
- Camerano, L., Absolute Force of Muscles, 673
- Notes on Gordii, 344
- Respiratory Movements of Coleoptera, 55
- Campanulacea, Vernation in, 222
- Campbell, D. H., Development of *Marattia*, 88, 481
- Cancer of Ash produced by Bacteria, 243
- Parasites, 273, 356, 698
- — Supposed, 213
- Skin, Parasite of, 355
- Cancerous Persons, Living Parasites in Blood, 580
- Candolle, C. de, Comparative Anatomy of Leaves, 222
- Cane, Sugar-, Diseases, 723
- Cantharidæ, Comparative Morphology of Abdomen of, 673
- Cantharidinæ, Hypermetamorphosis, 334
- Capellini, G., *Rhizocrinus Santagatai*, 349
- Capitan, L., Part played by Microbes in Society, 391
- Capparidææ, Localization of Active Principles in, 218
- Capsules, Petri's, Counting Apparatus specially adapted for, 393
- Carazzi, D., Bleaching Animals and Sections Fixed with Osmic Mixtures, 334
- Genus *Polydora*, 199
- Carbohydrates, Accumulation in Leaves, 217
- Formation and Transformation, 713
- Intramolecular Respiration Dependent upon, 594
- Carbon Dioxide and Oxygen, Exchange, 711
- Carcinus Mænas*, Correlated Variations in, 195
- Cardiac Ventricles, Nerve-supply of, 755
- Cardium muticum*, Eyes, 671
- Carleton, C. A., Germination of Uredinææ, 380
- Carlgen, O., Minyadæ, 350
- Carotid Gland, Development, 323
- Carpenter, G. H., Irish Pycnogonida, 562
- Carruthers, W., Cross-Fertilization of Cereals, 226
- Carus, J. V., Index to "Zoologischer Anzeiger," 49
- Caspian Crustacea, 679
- Cassedebar, P. A., Action of Sea Water on Microbes, 727
- Castracane, F., Spores of Diatoms, 239
- Stereoscopic Vision applied to Diatoms, 628
- Cat, Development of Hypophysis Cerebri, 35
- Catkins, Female, in *Populus*, 222
- Catterina, G., Pathogenic Bacillus of Frogs, 730
- Cattle, Adult Cestodes of, 345
- Coccidium in, 577
- Caucasian Field Mice, *B. typhi murium* and, 613
- Caulerpa*, Structure, 376
- Caullery, M., Budding of Diplosomidæ and Didemnidæ, 671
- Degeneration of *Distaplia*, 442
- Genital Products in Polyclimidæ, 330
- Cavara, F., Male Flowers of Box, 587
- New Zymogenous *Saccharomyces*, 95
- Parasitic Fungi, 93
- — *Hymenogaster*, 724
- Cazeneuve, —, Microbicidal Action of Gallanol, 527



- Celakovsky, L. J., Cladodes of *Asparagæ*, 472
- Cupule of *Quercus*, 80
  - Double Leaves of Honeysuckle, 706
  - Navel of Apophyse of Fruit-scales of *Pinus*, 364
  - Stigmatic Lobes of *Iris*, 80
- Cell and Animal Tissues, 549
- Chemical Physiology, 666
  - -division of Diatoms, 239
  - -divisions, Specific Character of, 326
  - -granules in Protozoa, 691
  - -inclusions, Parasitic, in Sarcomatous Tissue, 213
  - — — and their Cultivation, 748
  - -life without Micro-organisms? 551
  - Minute Structure, 43
  - -nuclei, Staining Crystalloids of, 275
  - -nucleus, Physiological Significance, 70
  - Physiology, 326
  - -structure of Phanerogams. See CONTENTS, xix
  - -substance, Interactions between, 43
  - -union in Herbaceous Grafting, 85
  - -wall of Fungi, Composition, 233
- Celli, A., Amœbæ and their Cultivation, 354
- Classification of Amœbæ, 694
  - Life of Amœbæ, 694
  - Transitory Variety of Cholera Vibrio, 498
- Celloidin, Imbedding Delicate Objects in, 404
- Preparations, Use of Stabilite, 753
  - Solutions, Air- and Water-free, 404
- Cells, Animal, Number of Chromosomes in, 549
- Degeneration, 326
  - Influence of Mechanical Resistance on Development, 711
  - Mounting Small Objects in, 534
  - of Blastoderm of Teleosteans, Karyokinetic Phenomena in, 41
  - of Phycocromaceæ, Structure, 240
  - Palisade-, and Transpiration, 470
  - Selective Power, in Absorption of Pigments, 276
  - Sex, Origin in *Hydractinia*, 576
  - Staining-differences of Male and Female, 277
  - — Living, 755
  - Wandering, of Frog, Changes induced by Urari in, 178
- Cellulose, Crystallization, 215
- Centrosomes and Nucleoles, 583
- in *Psilotum*, 360
- Centrospheres in Spores of *Pellia*, 581
- of Nucleus and Size of Cells, 581
- Cephalopoda. See CONTENTS, x
- Cercaria echinata*, Development and Formation of Excretory Canals in, 572
- Cercis*, Leaf-movement, 712
- Cereals, Cross-fertilization, 226
- Diptera destructive of, 675
- Cerebellum, Development in Teleostei, 547
- Cerebral Physiology of Worms, 681
- Cerfontaine, P., New Tristomid, 571
- Striated Muscular Fibres in Trematode, 571
  - Trichinosis, 65
- Cestodes, Adult, of Cattle, Sheep, &c., 345
- Preparation, 273
- Chadwick, H. C., Examination of Starfishes, 631
- Hæmal and Water-vascular Systems of Asteroidea, 574
- Chaetomorpha Hemmingsii*, 91
- Chaetonema*, Bulbils, 599
- Chaetophoraceæ, Epiphytic and Endophytic, 90
- Chaetopoda, Supporting Tissues of Nervous System of, 198
- Chamberland Filter, Système André, 529
- Chantre, E., Microbic Origin of Purulent Surgical Infection, 249
- Chapeau, M., Digestion of Cœlentera, 350
- Chapman, D., *Urobacillus liquefaciens septicus*, 613
- F., Foraminifera of Gault of Folkestone, 153, 421, 540, 645, 763
  - T. A., Notes on Micro-Lepidoptera, 443
- Characeæ. See CONTENTS, xxv
- Charrin, A., Influence of Cosmic Agents on Development of Bacterial Cell, 503
- — of Electricity on Microbe-cell, 391
  - Properties of *B. pyocyano-genus* as affecting Nutrient Qualities of its Medium, 614
- Chatin, A., Variety and Localization of Organs an Evidence of Gradation, 471
- J., Development and Formation of Excretory Canals in *Cercaria echinata*, 572
  - P., Atmospheric Streptococci, 498
- Chautriau, M. G., Localization of Alkaloids, 703
- Chauveaud, C., Germination of Seeds, 476
- G., Movements of Stamens of *Berberis*, 712
- Chelonia, Development of Gill-Pouches and Aortic Arches in, 38
- Gastrulation, 664
- Chemical Changes in Phanerogams. See CONTENTS, xxiv
- Physiology of Cell, 666
- Chemistry, Micro-, 522
- of Cell-wall, 583
  - of Chlorophyll, 702
  - of Organisms, 438
  - of Protoplasm, 45
- Chemotropic Movements, 479
- Chernetidæ, 56
- Cheshire, F. R., The late, 743

- Chestnut, Female Flower and Fruit, 79  
 Chicago Exhibition, 146  
 — Water Supply, Organisms in, 328  
 Chick, Development of Wolffian Body in, 36  
 — Formation of Somatopleure and Vessels in, 344  
 — Sero-anniotic Connection and Foetal Membranes, 663  
 Child, C. M., Antennary Sensory Organs of Insects, 185  
 Chilian Crustacea, 677  
 Chilopoda, Poison-glands of, 676  
 Chilton, C., Subterranean Crustacea of New Zealand, 678  
 Chimney for Lamp, 108  
 Chiton, Embryology, 49, 129  
 Chitons, Circulatory and Renal Organs, 440  
 Chittenden, R. H., Chemical Physiology of Cell, 665  
 Chlamydomonadineæ, 92  
 Chloragogen of *Ophelia radiata*, 341  
*Chlorocystis*, 92  
 Chlorophores of *Spirotania obscura*, 90  
 Chlorophyceæ, new Genus of, 485  
 Chlorophyll, Absorption-spectrum, 701  
 — Chemistry, 702  
 — Production of, 592  
 — -grains in Seeds and Seedlings, 584  
 Chlorophyllous Plants, Purification of Streams, 714  
 Chlorophylls, Occurrence of several, in same Plant, 702  
 Chodat, R., Classification of Lower Green Algæ, 597  
 — Development of *Pediastrum*, 599  
 — — of *Raphidium*, 605  
 — *Scenedesmus*, 382  
 — Structure of Cells of Phycchromaceæ, 241  
 Cholera and Vibrios, 730  
 — Asiatic, Value of Bacteriological Diagnosis, 388  
 — Bacilli, Action of some Sozoidol Preparations and of Tribromophenol-bismuth on, 281  
 — — Growth on Potato, 128  
 — Bacillus and Tobacco, 499  
 — — Vibrio resembling, 247  
 — Cultivating on Eggs, 526  
 — Cultivation in Uschinsky's Medium, 400  
 — Cultures, Absence of Phosphorescence in, 399  
 — Diagnosis by Microscope, 535  
 — Plate Diagnosis of, 526  
 — Vibrio and Diagnosis of Cholera, 612  
 — — Artificial Variation of, 499  
 — — Blood Serum as Diagnostic Cultivation Medium for, 269  
 — — of the Epidemic in Holland, 731  
 — — Transitory Variety of, 498  
 — — Variations, 731  
 — Vibrios, Easy Method for demonstrating in Water, 274  
 Cholera, Water Vibrios and the Ætiology of, 101  
 Choleroïd Vibrio, New Species, 498  
 Cholodkowsky, N., *Tœnia Brandti*, 455  
 Chordata, Phylogeny, 438  
*Chordeuma germanicum*, 191  
 Chordotonal Organs in Ants, 334  
 Chromatic Aberration of Lenses, 116  
 Chromatophily of Nuclei of Embryo-sac, 473  
 Chromatophores, 584  
 Chromogenic Water Bacteria, 245  
 Chromosomes, Number in Animal-cells, 549  
*Chroococcus minor*, 17  
 Chudiakow, N. v., Intramolecular Respiration, 713  
 Chun, C., Luminous Organs and Compound Eyes, 336  
 Church, A. H., Parasites on Algæ, 88  
 Chvovski, K., Bacteriological Investigation of Water of Basle, 614  
 Chytridiaceæ, 377, 718  
 Cichoriaceæ, Laticiferous Hairs of, 223  
 Cilia and Pseudo-cilia, 701  
 — of Bacillus, Composite, 384  
 — of Bacteria, New Method of Staining, 405  
*Cilliba cassidea*, 307  
 — *pandata*, 300, 308  
 — *romana*, 308  
 Circulatory Organs of Chitons, 440  
 — System of *Dreissensia polymorpha*, 442  
 Cirripedia, 450  
 — Buccal Apparatus, 196  
 — Development, 336, 403  
 Citric Acid, Effect on Diphtheria Bacillus, 728  
 — — Function in Assimilation, 230  
 — — Fungi which produce, 235  
 Cladodes of Asparagææ, 472  
*Cladosporium herbarum*, Polymorphism, 94  
*Cladotrix*, Polymorphism, 726  
 Clark, W. B., Mesozoic Echinoderma of United States, 689  
 Clarke, J. J., Parasites of Cancer, 699  
 — S. F., Hydroids of 'Albatross,' 351  
 Classification of Amœbæ, 694  
 — Arthropoda, 331  
 — Diatoms, 382  
 — Ferns, 481  
 — Inulidæ, 675  
 — Lower Green Algæ, 597  
 — Myxosporidia, 465  
 — Pyrenomyces, 601  
 — Sigillariæ, 374  
 — Sporozoa, 71  
 — Tubers, 367  
 Claus, C., Metamorphosis of Freshwater Ostracoda, 681  
 — New Observations on *Cyclops*, 59  
 — Skeleton of Copepoda, 59  
 — The Pontellidæ, 58  
 Claussen, R., Variations of the Cholera Vibrio, 731  
 Clay Wick, 738

- Claypole, E. J., Investigation of Blood of *Necturus* and *Cryptobranchus*, 402  
*Claytonia*, Fertilization, 84  
 Cleaning Cover-glasses, 135, 535, 642  
 Cleistogamy, Occasional, 709  
*Clepsine*, Eye, 62  
 Cleve, P. T., Synopsis of Naviculoid Diatoms, 765  
 Clinton, G. R., *Pleodrina*, A new Genus of Volvocineæ, 718  
 Clitellum of Earth-worm, 200  
 Clos, D., Classification of Tubers, 367  
*Closterium abruptum*, 3  
 — *intermedium* var. *Hibernicum*, 3  
 — *subpronum*, 3  
*Cobæa*, Movements of Flower-stalk, 229  
 Cobb, N. A., Australian and Fijian Nematodes, 202  
 — Diseases of the Sugar-Cane, 723  
 — Nematodes and Sugar Cane, 570  
 — New Genera of Nematodes, 451  
 Cocci, Pneumonia, Sputum as Cultivation Medium for, 271  
 — Pyogenic, Mixed Infection from, 248  
 Coccidian Infection, Double, 696  
 Coccidium in Cattle, 577  
*Coccidium oviforme*, Development in Bile-duct of Rabbits, 355  
*Coccinia*, Cystoliths, 471  
 Cocco-bacillus, Red, of Sardine, 389  
 Cockerell, T. D. A., Check-List of Slugs, 183  
 Cœlentera. See CONTENTS, xvii  
 Cœlomic Cavity of Spider, 676  
 Coffee-Disease, Nematode, 452  
 Cohn, F., Formation and Erosion of Rocks by Algæ, 597  
 — Thermogenous Bacteria, 384, 733  
 — Uses of Formaldehyd, 642  
 Cold, Influence on Vitality of Malaria Parasites, 357  
 Cole, F. J., Clitellum of Earth-worm, 200  
 Coleoptera of the United States, Tertiary Rhynchophorous, 674  
 — Pigmentation in Scales of, 186  
 — Respiratory Movements, 55  
 Coli Group of Bacteria, 499  
 Collecting Objects. See CONTENTS, xxxii  
 Collinge, W. E., Absence of Male Reproductive Organs in two Hermaphrodite Molluscs, 46  
 — Check-List of Slugs, 183  
 Colony Counter, Modification of Wolfhügel's, 529  
 Colorimeter, with Lummer-Brodhun Prism Pair, 740  
 Colour Sensations, Measurement, 119  
 Comber, T., 146, 415, 538, 767  
 — Cleve's Synopsis of Naviculoid Diatoms, 765  
 — Unreliability of certain Characters generally accepted for specific Diagnosis in Diatomaceæ, 428, 539  
 Combretaceæ, Anatomy, 221  
 Commensals, Food of two, 667  
 Compass Plants, 712  
 Compositæ, Achenial Hairs, 367  
 — Puccinias Parasitic on, 238  
 — Succulent, 365  
 — Vernation in, 222  
 Compressorium, New, 759  
 Condon, H., Ammoniacal Fermentation of Earth, 244  
 Congo Earthworms, 343  
 Coniferæ, Seedlings, 220  
 Conifers, Size of Leaves, 472  
 Conjugatæ, New Organ of, 717  
 Conklin, E. J., Preparing Molluscan Ova, 272  
 Conservation of Bacterial Cultivations by means of Formalin, 130  
 Conversazione, April 4th, 1894, 409  
*Convolvulus arvensis*, Dimorphism of Flowers, 84  
 Cooper, A. W., Diatoms from Natal, 765  
 Copeman, S. M., Parasite of Vaccinia and Variola, 698  
 Copepod, Flying, 681  
 — Gall-producing, 168, 283  
 Copepoda of Liverpool Bay, 450  
 — Skeleton, 59  
 Copulation of Cephalopoda, 554  
 Copulatory Organs of Libellulidæ, 53  
 — of Male Hymenoptera, 53  
 Cordemoy, H. J. de, Root of Arborescent Liliaceæ, 221  
*Corethron*, 762  
 Cori, C. J., Stage-Aquarium, 121  
 Cornacuspongiæ, Development, 209  
 Corpuscles, Demonstrating Nucleated Red, 639  
 — Rapid Staining of Blood, 756  
 Correns, C., Internal Structure of Cell-wall, 215  
 — Transverse Lamellation of Membrane of Bast-cells, 216  
*Cosmarium annulatum*, 7  
 — *asperum*, 8  
 — *bipapillatum*, 7  
 — *exiguum* var. *pressum*, 6  
 — *furcatospermum*, 7  
 — *Holmiense* var. *undatum*, 5  
 — *Lundellii* var. *ellipticum*, 5  
 — *prominulum* var. *subundulatum*, 6  
 — *promontorium*, 7  
 — *pyramidatum* var. *angustatum*, 5  
 — *Scoticum*, 6  
 — *subretusiforme*, 5  
 — *subundulatum* var. *Beanlandii*, 7  
 — *tetragonum* var. *punitum*, 5  
 — *Thwaitesii* var. *Scoticum*, 8  
 Costantin, J., Fixity of Race in Mushrooms, 723  
 — Fungi of *Favus*, 605  
 — New Genera of Fungi, 378  
 — Parasites of Mushroom, 723

- Costerus, J. C., Storing up and Transport of Starch, 593  
 Council Report for 1893, 148  
 Counter, Modification of Wolffhügel's Colony, 529  
 Counting Apparatus specially adapted for Petri's Capsules, 393  
 Coupin, H., Food of two Commensals, 667  
 Coutant, R. B., Support for Microscope, 736  
 Cover-glasses, Cleaning, 135, 535, 642  
 Cox's Method of Demonstrating the Nerve-fibres of Central Nervous System, 134  
 — J. D., Plea for Systematic Instruction in Technique of Microscope at the University, 627  
 Crabronidæ, Salivary Glands, 334  
 Cramer, E., Composition of Spores of *P. glaucum*, and its relation to their power of withstanding external Influences, 503, 614  
 Crampton, H. E., Reversal of Cleavage in a Sinistral Gastropod, 669  
 Craspedote Medusæ of Plankton, 575  
 Crato, E., Physodes, 359  
 Crayfish with Abnormal Appendages, 195  
 Crayfishes, Leech-like Parasites of American, 343  
 Crinoids, Silurian, 68  
*Cristellaria Bononiensis*, 652  
 — *Bradyana*, 654  
 — *Bronni*, 649  
 — *complanata*, 653  
 — *costulata*, 649  
 — *crepidula*, 648  
 — *cymboides*, 647  
 — *exilis*, 647  
 — — var. *crispata*, 647  
 — *gladius*, 649  
 — *humilis*, 648  
 — *Italica*, 653  
 — *latifrons*, 652  
 — *linearis*, 645  
 — *lituola*, 650  
 — *navicula*, 650  
 — *oligostegia*, 651  
 — *parallela*, 647  
 — *planiuscula*, 654  
 — *Schloenbachi*, 649  
 — *scitula*, 662  
 — *striata*, 646  
 — *sulcifera*, 650  
 — *triangularis*, 651  
 — *tripleura*, 652  
 — *trunculata*, 651  
 — *vestita*, 653  
 Cristiani, H., Apparatus for Bacteriological Examination of Air, 398  
*Crocus*, Development of Flowers, 472  
 Crombie, J. M., British Lichens, 489  
 Crookewit, J. M., Jaws of Hirudinea, 62  
 Crosa, F., New substance extracted from Lichens, 488  
*Croton*, Nucellus of Ovule, 368  
 Crova, —, New Photometry, 739  
 Cruciferae, Structure of Flower, 472  
 Crustacea of British Columbia, 328  
 — Study of Spermatogenesis, 272  
 — See CONTENTS, xiii  
 Crustacean Appendages, Morphology, 52  
*Cryptobranchius*, Investigation of Blood, 402  
 Cryptogamia. See CONTENTS, xxiv  
*Cryptoglena americana*, 490  
 Crystallization of Cellulose, 215  
 Crystalloids of Cell-nuclei, Staining, 275  
 — Proteinaceous, 468  
 Crystals, Instrument for producing Monochromatic Light, its use in investigating Optical Properties of, 394  
 — Obtaining Hæmin, 273  
 — Photomicrograms of Ice and Snow, 711  
 Csapodi, S., Fungi which feed on Arsenic, 377  
*Cucurbita*, Growth of Fruit, 369  
 Cucurbitaceæ, Hybridism in, 475  
 — Localization of Active Principles, 361  
*Cucumaria glacialis*, Anatomy and Development, 456  
 Cuénot, L., Defensive Ejection of Blood, 445  
 — Function of Kidney of *Helix*, 670  
 — Physiology of Decapod Crustacea, 194, 449  
 Culture Processes. See CONTENTS, xxxii  
 Cunningham, K. M., Remarkable Collection of Photomicrographs, 262  
 Cupule of *Quercus*, 80  
 Curties, C. L., Apparatus for obtaining Instantaneous Photomicrographs, 417, 516  
 — Edinger's Photographic and Drawing Apparatus, 285  
 — Photographic Microscope, 417, 517  
*Cuscuta*, Biology, 480  
 Cuticular Formations, 584  
 Cutting Objects. See CONTENTS, xxxiv  
 Cyanophyceæ, Protoplasts of, 383  
*Cyca*s, Symbiosis of Algæ and Bacteria with, 478  
 — Venation, 223  
*Cycelas*, Oogenesis in, 330  
 Cyclopidæ, Antennæ, 58  
 — Parasites, 71  
*Cyclops*, 58  
 — New Observations, 59  
*Cylindrocystis diplospora*, 4  
*Cymatogaster aggregatus*, Yolk-nucleus in, 548  
 Cyperaceæ, Distribution of Seeds, 368  
 Cystic Worms of *Bothriocephalus* in German Fishes, 346  
 Cystoliths of *Coccinia*, 471  
*Cystopteris bulbifera*, Bulbs, 595  
*Cystopus candidus*, Malformations produced by, 234  
 Cytoplasm, Independence of Nucleus and, 467



## D.

- Dahmen, M., Bactericidal Properties of Vasogen, 387
- Daland, J., New Method of Separating White from Red Blood-corpuscles by means of the Hæmatokrit, 278
- Dallinger, W. H., 138, 417, 761  
— Piffard's Method of Increasing the N.A. of Old Achromatic Object Glasses, 413, 519  
— Stereoscopic Photomicrographs, 413, 537  
— Swift's Microscope, 285  
— — Stage, 537
- Damma Island, Terrestrial Fauna, 552
- Dana, J. D., Derivation and Homologies of some Articulates, 442
- Danby, W. H., Entomology of British Columbia, 328
- Dangeard, P. A., Histological Structure and Development of Yeasts, 95  
— Nuclei of Mucorini, 486  
— *Polysporella*, 212  
— Seedlings of Coniferæ, 220  
— Sexual Reproduction among Ascomycetes, 719  
— — — in Fungi, 485  
— — — in Ustilagineæ, 719  
— *Stichococcus bacillaris*, 725  
— Structure of Lichens, 487  
— — Nucleus in Mucorini, 701  
— — Ustilagineæ, 487  
— — Yeasts and their Development, 720
- Daniel, L., Morphology and Physiology of Grafting, 476
- Danilewsky, W., Hæmatozoa in Animals, 358
- Danzsz, J., Destruction of Field Mice by Pathogenic Microbes, 247
- Daphnia*, Alimentary Canal, 196
- Darbyshire, O. V., *Phyllophora*, 484
- Darier's Disease, Psorosperms of, 73
- Darwin, F., Growth of Fruit of *Cucurbita*, 369
- Dasya*, Stichids, 376
- Davenport, C. B., Regeneration in *Obelia*, 459
- Davis, B. M., *Cryptoglena americana*, 494
- Dawson, W. R., Manual of Bacteriology, 502
- De Amicis, G. A., Pliocene Foraminifera, 577
- Decapod Crustacea, Physiology, 194, 449  
— — Spermatogenesis in, 193
- Deckenbach, K., Polymorphism of *Trentepohlia*, 233
- Degeneration of *Distaplia*, 442
- Dehérain, P. P., Unequal Resistance of Plants to Drought, 85
- Delacroix, G., Bacillar Diseases of Plants, 492
- Delacroix, G., Parasitic Fungi, 378, 379, 488
- Delépine, S., Influence of Natural Agents on Virulence of Tubercle Bacillus, 726  
— Value of Bacteriological Diagnosis of Asiatic Cholera, 388
- Delpech, —, Pyelonephritis due to *Staphylococcus pyogenes aureus*, 613
- Demoor, J., Independence of Nucleus and Cytoplasm, 467  
— Physiology of Cell, 326  
— L., Investigation of Reticulated Tissue, 130  
— Structure of Reticulated Tissue, 44
- Demoussy, —, Nitrates in Living Plants, 469
- Dendy, A., Comparative Anatomy of Sponges, 461  
— Crayfish with Abnormal Appendages, 195  
— Hatching of *Peripatus* Egg, 191  
— Land Planarians from Tasmania and South Australia, 202
- Dentition of Mammals, 173  
— of Pinnipedia, 36  
— of Rodents, Milk, 542  
— of Wombat, 37
- Denys, J., Bactericidal Power of Blood, 98  
— — — Body Juices, 729  
— Diagnosis of Cholera by Microscope, 535  
— Leucocytes and Bactericidal Power, 492  
— Relations of Friedlaender's *Pneumobacillus*, and of Lactic Ferment with *B. lactis aerogenes* and *B. typhosus*, 245
- Desmidiaceæ, Pores, 484
- De Toni's Sylloge Algarum, 600
- Deycke, —, Nutrient Media containing Alkali Albuminates, 750
- Diarrhœa, Infusoria of, 463
- Diastatic Ferment, 713
- Diatomaceæ, Unreliability of Characters accepted for Specific Diagnosis, 428, 539
- Diatomaceen-Kunde, Schmidt's Atlas, 240
- Diatoms, Cleaning, 278  
— from Natal, 765  
— Influence of Light and of Altitude on Striation, 491  
— Intra-frustular Reproduction of, 382  
— Movements, 382, 606  
— Naviculoid, 765  
— New Genera, 240  
— Nucleus, 240  
— Re-establishment of Size, 606  
— Relationship between Morphology, Biology and Classification, 382  
— Spores, 239  
— Stereoscopic Vision applied to, 628  
— Structure and Cell-division, 239
- Dichothrix Baueriana* var. *Hibernica*, 17  
— *interrupta*, 16

- Dicotyledonous Herbs and Shrubs, Medullary Rays, 470  
*Dictyosphaerium*, Development, 605  
 Dicyemida, 287  
 Didemnida, Budding, 671  
 Dictel, P., Alternation of Generations in Uredineæ, 603  
 — On *Uredo Polypodii*, 391  
 — *Ravenelia*, 490  
 — Teleutospores of Uredineæ, 603  
 Digestion of Coelentera, 350  
 — Role of Acid in Protozoan, 462  
*Dimorpha mutans*, 463  
 Dimorphism due to Parasitism, 439  
 — in Japanese Butterflies, Seasonal, 444  
 Dinard, Polychæta, 682  
*Dinychus perforatus*, 311  
*Dionæa*, Insectivorous Habit of, 231  
 Dioscoreaceæ, Anatomy of Stem, 78  
 — Bulbils, 83  
 Diphtheria Bacillus, Effect of Citric Acid on, 728  
 — — Isolating from Toys, 128  
 — — Urine-Agar for Cultivating, 128  
 — Immunity, 727  
 — Secondary Foci in Experimental, 610  
 — Viability Period, 248  
*Diplococcus pneumoniae*, Presence in Osteomyelitis and Periostitis, 245  
 Diplosomidæ, Budding, 671  
 Diptera, destructive of Cereals, 675  
 — Parasitic on Acrididæ, 560  
 Dipterous Parasites of Locusts, 446  
*Discopoma cassidea*, 307  
 — *pandata*, 300  
 — *romana*, 308  
 Disinfectants, Influence of Alcohol, Glycerin, and Olive Oil on, 608  
 Disinfection Experiments, Technique, 528  
 Dissard, A., Properties of *Bacillus pyocyano-genus* as affecting Nutrient Qualities of its Medium, 614  
*Distaplia*, Degeneration, 442  
 — *magnilarva*, Metamorphosis of, 330  
*Distomum*, Monograph on, 687  
 — *clavigerum*, 65  
 — *Westermanni* in United States, 345  
 Distribution of Lacustrine Plankton, 552  
 Dithion, New Antiseptic, 281  
*Ditiola*, Systematic Position, 723  
 Diversion, A Little, 523  
 Dixey, F. A., Phylogeny of Pierinæ, 443  
 — Temperature Experiments on Lepidoptera, 673  
 Dixon, H. H., Fertilization of *Pinus*, 474  
 — Germination of Seeds, 477  
 — Walking of some Arthropoda, 557  
 — Nuttall, F. R., Notes on Rotifers, 346  
 Dog's Blood, its Bactericidal Power and Richness in Leucocytes, 610  
*Doliolum*, New, 51  
 Donaldson, H. H., Changes caused in Nervous Tissue by Hardening Reagents, 642  
 — Macrae Electric Company, New Machine for Cutting Thin Sections of Rocks and Minerals, 533  
 Doria, F. R., Protozoa in Endometritis, 696  
 Doridiidæ, 46, 179  
 Dornberger, —, Streptococci in Healthy and Unhealthy Mouth, 498  
 Draer, A., Action of some Sozoidol Preparations, and of Tribromophenol-Bismuth on Cholera Bacilli, 281  
*Draparnaldia*, Zoospores, 91  
 Drasch, O., Formation of Somatopleure and Vessels in Chick, 544  
*Dreissensia polymorpha*, Circulatory System, 442  
 — — Nervous System, 328  
 Dreyfus, I., Composition of Cell-wall of Fungi, 234  
 — L., Anatomy of Phylloxeridæ, 675  
 Driesch, H., Experimental Embryology illustrated by Echinoderms, 347  
 Dronig, M., Root-tubers, 223  
 Drosbach, G. P., Examining Water for Anaerobic Bacteria, 527  
 Drought, Unequal Resistance of Plants to, 85  
 Druner, L., Degeneration of Cells and Nuclei, 326  
 Duboseq, O., Poison-Glands of Chilopoda, 676  
 Dubourg, E., Presence of Mannite in Wine, 373  
 Ducamp, —, Bacteriological Study of Drinking Water of Montpellier, 391  
 — Note on Fluorescent and Liquefying Bacillus of Drinking Waters of Montpellier, 503  
 Duclaux, E., Analogies between Fermentation and Solar Combustion, 481  
 — Microbes and Fatty Matter, 244  
 — Part played by Microbes in Agriculture, 391  
 — Spontaneous Purification of River Water, 714  
 Duerden, J. E., Irish Hydroida, 208  
 — New and Rare Irish Polyzoa, 185  
 Dunbar, —, Investigation of Cholera-like Aquatic Bacteria, 102  
 Duramen and Albumum, Comparison, 219  
 — Characteristics, 218  
 Durand, E. J., New Myxomycetes, 490  
 Dust, Street, Examining for Tubercle Bacilli, 134  
 Dyes, Anilin, Staining Tubercle Bacilli in Sublimite Solutions of, 276  
*Dytiscus*, Spermatozoa, 52

## E.

Earth, Ammoniacal Fermentation, 244  
 — Experiments as to Vitality of Anthrax Spores in, 527  
 Earthworm, Bifid, 343  
 — Clitellum of, 200  
 — Free Nerve-endings in Epithelium, 568  
 Earthworms, Anatomy and Development, 569  
 — Exotic, 200  
 — from Congo, 343  
 — New, from W. Tropical Africa, 569  
 — New Irish, 62  
 — Victorian, 200  
 Eberth, C. J., Microscopical Technique, 137  
 Echinoderma. See CONTENTS, xvi  
 Ectoderm in *Necturus*, Ontogenetic Differentiations, 39  
 Ectodermic Differentiation in *Necturus*, 544  
 — Origin of Skeletal Rudiments, 35  
 Edinger's Photographic and Drawing Apparatus, 285  
 Efferent Canal of Glossiphoniidae, 683  
 Eiffont's Process for Purification and Preservation of Yeast, 236  
 Egg-albumen, Cultivation Medium, 268  
 Egg, Hatching of *Peripatus*, 191  
 — of *Axolotl*, Maturation and Fertilization, 23  
 — of Trout, Fecundation, 324  
 — Simple Method for producing Two or More Embryos from One, 630  
 Egg-yolk Medium for Cultivating Influenza Bacillus, 269  
 Egger, J. G., Foraminifera of 'Gazelle,' 354  
 Eggs, Cultivating Cholera on, 526  
 — *Limax maximus*, Examination, 531  
 — *Moina*, Winter and Summer, 196  
 — Preparation of Nutrient Medium for Bacteria from, 399  
 — Teleosteans, Experimental Studies, 40  
 — Trout, Preparation, 272  
 Ehlers, E., Contributions to our Knowledge of Polyzoa, 185  
 Ehrmann, S., Weigert's Fibrin Method, 407  
 Eijkmann, C., Microbiology and Manufacture of Arrack, 602  
 Eisen, G., Californian Eudrilidae, 342  
 Eismond, J., Development of *Amphioxus*, 549  
 Ekstam, O., Cross- and Self-pollination, 709  
 Elaiospheres and Elaioplasts, 704  
 Elaioplasts, 76, 704  
 — in Liliaceae, Development, 467  
 Elaters of Hepaticae, 716  
 Electric Lantern, Triple Rotating, 410  
*Eledone*, Spawn and Embryos, 555

*Eledone cirrhosa*, Bilateral Hectocotylyzation, 46  
 Elfving, F., Irritability in Plants, 479  
 Elliot, L. B., Karyokinesis, 467  
 Elsching, A., Air and Water-free Celloidin Solutions, 404  
 — Imbedding Delicate Objects in Celloidin, 404  
 Elsner, —, Plate Diagnosis of Cholera, 526  
*Elysia*, Excretory and Reproductive Apparatus, 180  
 Embryo of Ferns, 373  
 Embryological Material, Methods for Examining, 752  
 Embryology, Experimental, illustrated by Echinoderms, 346  
 — *Chiton*, 49, 129  
 — *Gebia littoralis*, 631  
 — Phanerogams. See CONTENTS, xxii  
 — Porifera, 461  
 — Vertebrates. See CONTENTS, vii  
 Embryonic Livers, Plate Models, 752  
 — Lobster, Histology of Nervous System of, 563  
 — Membranes of Arthropoda, 672  
 — Mitoses, 550  
 Embryos, Ascidian, Origin of Peribranchial Cavity in, 50  
 — Chelonia, Preparation and Preservation, 750  
 — Fish, Study of Living, 631  
 — of *Eledone*, 555  
 — Simple Method for producing two or more from one Egg, 630  
*Emea lacustris*, 202  
 Emery, C., Evolution of Worker-Caste among Ants, 332  
 Enchytraeidae, Structure, 201  
 Endogens, Origin, 87  
 Endoglobular Parasites of Blood of Vertebrates, 578  
 — — Study, 632  
 Endometritis, Protozoa in, 696  
 Endophytic Chetophoraceae, 90  
 Endosperm of *Phytelephas* and *Smilacina*, 589  
 Endosternite of Arachnida, 55, 448  
 — of *Scorpio*, 192  
 Engel, S., Simple Photomicrographic Camera, 393  
 Engelmann, T. W., Production of Oxygen and Chlorophyll, 592  
 Engler, A., Icacinaceae, 79  
 English Channel, Bipinnariæ from, 207  
 — Spiders, Instincts of Common, 55  
 Enteric Canal of Echinoderma, 206  
 Enteritis, Amœba-, 696  
 Enteropneusta, 203  
 Entomology of British Columbia, 328  
 Entomotraca from Gulf of Guinea, 680  
 — of Wanstead Park, 367  
 Enzymes, 360  
*Ephedra*, Embryology, 708

- Epinasty and Geotropism, 370  
*Epiphegus*, Parasitism, 586  
 Epiphysis of Teleostean Fishes and of *Amia*, 546  
 Epiphytes, Aerial Roots, 588  
 Epiphytic Chaetophoraceae, 90  
 Epithelium of Earthworm, Free Nerve-endings in, 568  
 Epstein, A., *Monocercomonas Hominis* and *Amœba coli*, 212  
 Equilibration, Function, 666  
 Equisetineae, Sporophyte, 88  
 Erlanger, R. v., Primitive Nephridia of *Lymnæus*, 556  
 Ermengem, E. Van, New Method of Staining Cilia of Bacteria, 405  
 Ernst, P., Spore-staining after Maceration, 757  
 Erp, M. J. van, Development of Müllerian Duct in Mammals, 322  
 Erysiphea-like Fructification in Saprolegniaceae, 600  
 Escherich, K., Male Reproductive Organs of Beetles, 673  
 Esmarch's Roll Tubes, Distribution of Bacteria Colonies in, 529  
 Etard, A., Occurrence of several Chlorophylls in same Plant, 702  
 Etiolation, 477  
*Euastrum oblongum* var. *cephalophorum*, 4  
 Eudrilidae, Californian, 342  
*Euglena*, Growth confined to Two Dimensions of Space, 692  
 — Nuclear Division in, 577  
*Euonymus*, Stipules, 366  
*Euphorbia*, Spherocrystals, 76  
*Euphrosyme*, Structure, 450  
 Europe, Filariosis in, 570  
 European Crustacea, 677  
 Eurypteridae, Anatomy and Relations, 192  
*Euterpes*, Origin of "Nasutus" of, 560  
 Evans, A. C., Action of Gravity on *Bacterium Zopfii*, 609  
 — Growing and Examining *Bacterium Zopfii*, 526  
 Evolution of Worker-Caste among Ants, 332  
 Excretory Apparatus of *Elysia*, 180  
 — Canals, Development and Formation in *Cercaria echinata*, 572  
 — Processes in Porifera, 461  
 — System in *Amphiuma*, Development, 435  
 — — of *Nephtelis*, 343  
 — Vessels of Tæniæ, Valvular Apparatus in, 454  
 Exoascete, 487  
 Exoderm of Roots, Waviness of Cell-wall of, 360  
 Eye, Derivation of Pineal, 176  
 — Median of Adult Crustacea, 449  
 — of *Clepsine*, 62  
 — of *Lecch*, 683  
 Eye of Phalangidae, 562  
 — of *Vanessa*, Development of Compound, 186  
 Eyeless Bivalves, Sense of Light in, 441  
 Eye-pieces. See CONTENTS, xxxi  
 — -spot, 701  
 Eyes, Composite, Insect Sight and Defining Power, 443  
 — Compound, Luminous Organs and, 336  
 — Lateral, in Galeodidae, 447  
 — of *Cardium muticum*, 671  
 — of Harvestmen, 335  
 — of *Salpa*, 183  
 — of *Scutigera coleoptrata*, 335
- F.
- Fabre-Domergue, —, Slide-holder, 407  
 Fahrman, O., Turbellaria-Fauna of Basle, 571  
 False Mimicry, 552  
 Famintzin, A., Chlorophyll-grains in Seeds and Seedlings, 584  
 Farmer, J. B., Centrospheres in Spores of *Pellia*, 581  
 — Nuclear Division in Pollen-mother-cells of *Lilium Martagon*, 74  
 — *Pallavicinia decipiens*, 483  
 — Relations of Nucleus to Spore-formation in Liverworts, 232  
 Farmer's Microscope, 106  
 Fatigue-substances, 361  
 Fatty Matter, Microbes and, 244  
*Favus*, Fungi, 604  
 Feundation of *Octopus vulgaris*, 554  
 Féré, C., Experimental Embryology, 661  
 Ferment, Diastatic, 713  
 — Lactic, Relations with *B. lactis aerogenes* and *B. typhosus*, 245  
 — Mannitic, in Wine, 373  
 — of Fungi, 377  
 Fermentation, Ammoniacal, of Earth, 244  
 — of Phanerogams. See CONTENTS, xxiv  
 Fermenting Grape- and Apple-must with Pure-bred Yeasts, 235  
 Ferments, Proteolytic, in Seedlings, 704  
 Fermi, C., Enzymes, 360  
 Ferns, Annulus of Sporangium, 374  
 — Classification, 481  
 — Embryo, 373  
 Ferroni, E., Supposed Cancer Parasites, 213  
 Ferry, R., Fossil Fungi, 605  
 Fertilization, Cross-, of Cereals, 226  
 — Egg of *Azollu*, 38  
 — Gymnosperms, 368  
 — Pucciniæ, 238  
 — Trout's Ovum, 435  
 Fever, Malta, Ætiology, 500  
 Fevers, Structure of Malaria Parasites of Summer and Autumn, 700  
 Fibrin Method, Weigert's, 407



- Fick, R., Maturation and Fertilization of Egg of *Axolotl*, 38
- Field, H. H., Development of Excretory System in *Amphiuma*, 435
- Figdor, W., Heliotropic Sensitiveness, 480
- Fijian Nematodes, 202
- Filamentous Form of *Protococcus*, 725
- Filaments of Tubercles of Papilionaceæ, 609
- Filaria immitis* in a Japanese Wolf, 65
- *uncinata*, History, 64
- Filariosis in Europe, 570
- Filarszky, F., Monograph of Characeæ, 716
- Filter, Air, 747
- Berkefeld, 267
- Hot, and Steam Sterilizer, Combination, 529
- Système André, Chamberland, 529
- Fins, Development of Teleostei, 547
- Fiocca, R., Amœbæ and their Cultivation, 354
- Classification of Amœbæ, 694
- Life of Amœbæ, 694
- Method for Spore-staining, 133
- Fir, Witch-broom of, 470
- Fischer, —, Presence of *Diplococcus pneumoniae* and *Streptococcus pyogenes* in Osteomyelitis and Periostitis, 245
- A., Fixing Methods and Granules, 758
- Flagella, 580
- B., Bacteriology of Plankton Expedition, 502
- New Form of Propagation in *Mycoderma*, 236
- E., Phalloideæ, 381
- Sclerote of *Rhododendron*, 602
- W., Gill-like Organs of *Sipunculus*, 683
- Fish-embryos, Study of Living, 331
- Fishes, Development of Teeth, 546
- British, Ova and Larvæ, 665
- German, Cystic Worms of *Bothrioccephalus* in, 346
- Teleostean, Epiphysis of, 546
- Vertebral Column, 41
- Fixing-board for Experiments on Animals, 760
- Flabellina didyma*, 159
- Flabellum anthophyllum*, 457
- Flagella, 580
- Staining, 405, 406, 640
- — without a Mordant, 756
- Flax-seeds, Mucilage-laver in, 78
- Fleurent, E., Composition of Vegetable Albuminoids, 217
- Flexner, S., Amœbæ in Abscess of Jaw, 72
- Flight of Locusts, 445
- Florida, Blind *Cambarus* from, 450
- Florieæ, New Genus, 89
- Flot, L., Fatigue-substances, 361
- Internal Pericycle, 219
- Flower of Chestnut, Female, 79
- Flower, Cruciferae, Structure, 472
- Flowering Plants, Embryology, 224
- Flower-stalk of *Cobæa*, Movements, 229
- Flowers, Bright Colour of Alpine, 705
- Influence of Light on, 227
- Movements, 229
- of Box, Male, 587
- *Convolvulus arvensis*, Dimorphism, 84
- *Crocus*, Development, 472
- *Schizanthus*, Mechanism, 712
- *Veronica*, Movements, 229
- Fluke, New Human Liver, 454
- Flux of Trees, Fungus, 604
- Flying Copepod, 681
- Foa, P., Demonstrating the Cancer Parasite, 273
- Parasites of Cancer, 698
- Foam and Protoplasm, Microscopic, 437
- Fock, A., Limits of the Visible, 395
- Fœtal Membranes of Chick, Sero-amniotic Connection and, 663
- Fog, Effects on Plants, 231
- Fol, H., the Late, 395
- Folkestone, Foraminifera of Gault, 153, 421, 540, 645, 763
- Font y Torné, M., Filariosis in Europe, 570
- Food in Italy, *Ligula* as, 573
- of *Sagitta*, 456
- two Commensals, 667
- -vacuoles of Infusoria, 353
- Foot, Madura, Parasite of, 390
- Foraminifera, Index to, 354
- Life-history, 694
- of Gault of Folkestone, 153, 421, 540, 645, 763
- 'Gazelle,' 354
- Pliocene, 577
- Reproduction, 353
- Formaldehyde for Hardening and Preserving, 277
- Preservation of Marine Animals in, 532
- Uses, 642
- Formalin as Hardening and Preservative Medium, 135
- Conservation of Bacterial Cultivations by means of, 130
- Test for Typhoid Bacillus, 268
- Formic Acid Hæmatoxylin, 405
- Formol as a Preservative Fluid, 758
- Fossil Bryophytes, 597
- Chara, 717
- Fungi, 605
- Plants, Employment of Vesuvium for, 133
- *Salvinias*, 595
- Starfishes, 204
- “Foul-water,” 418
- Fowler, G. H., New Veretillid, 576
- *Octineon Lindahli*, 208
- Francé, R., Polytomæ, 579
- Frank, B., Assimilation of Free Nitrogen by Plants, 86

- Frank, B., Parasitic Fungi, 378  
 Franze, R., Chlamydomonadineæ, 92  
 — R. H., Low Forms of Algæ, 376  
 Frebault, A., Chemistry of Organisms, 438  
 Fredericq, L., Autotomy in the Animal Kingdom, 438  
 Fremlin, H. S., Differences between *B. coli commune* and *B. typhosus*, 611  
 French Nemertinea, 571  
 Frenzel, J., Enteric Canal of Echinoderma, 206  
 — Histology of Mid-gut Gland, 440  
 Freshwater Algæ, New British, 1  
 — Medusa from the Niger, 351  
 — Ostracoda, Metamorphosis of, 681  
 — Turbellaria, Asexual Reproduction in, 685  
 Freudenreich, E. v., Microbes and the part they play in Milk Industry, 391  
 — Resistance of Bacteria to Pressure combined with High Temperature, 97  
 Friedländer's Microscopical Technique, 137  
 — *Pneumobacillus*, Relations with *B. lactis aerogenes* and *B. typhosus*, 245  
 Friedrich, P., Heating Arrangements of Microscope for Bacteriological Purposes, 630  
 Friend, H., New Irish Earthworms, 62  
 Fritze, A., Seasonal Dimorphism and Polymorphism in Japanese Butterflies, 444  
 Frog, Changes induced by Urari in Wandering Cells of, 178  
 — Ova, Degeneration, 545  
 — -spawn Fungus, New, 729  
 Frogs, Pathogenic Bacillus, 730  
*Fronicularia Archiaciana*, 155  
 — *Cordai*, 159  
 — *denticulocarinata*, 155  
 — *gaultina*, 155  
 — *Guestphalica*, 158  
 — *inversa*, 155  
 — *Karreri*, 156  
 — *lanceola*, 157  
 — *Loryi*, 154  
 — *microdiscus*, 158  
 — *Parkeri*, 157  
 — *perovata*, 158  
 — *pinnæformis*, 156  
 — *planifolium*, 158  
 — *quadrata*, 158  
 — *strigillata*, 157  
 — *Ungeri*, 157  
 Fructification in Saprolegniaceæ, Erysiphea-like, 600  
 — of *Juniperus*, 363  
 Fruit, Alder, Sclerote in, 720  
 — Influence of Pollen on, 368  
 — bearing Axis of Palms, 705  
 — of *Bennettites*, 363  
 — of Chestnut, 79  
 Fruit of *Cucurbita*, Growth, 369  
 — -scales of *Pinus*, Navel of Apophyse of, 364  
 Fruits, Adaptation to Climate, 706  
 — Localization of Fatty Oils in Formation of, 468  
 Fucaceæ, Irritability of Spermatozooids of, 599  
*Fucitroqus Rhodymenia*, 168, 283  
*Fucoides*, 600  
 Funck, E., Cleaning Cover-glasses, 642  
 Fungi, Anatomy of Cell, 74  
 — Cultivation Capsule for, 746  
 — Inspissated Must and Cultivation of, 270  
 — Skin, Natural Pure Cultivations, 530  
 — See CONTENTS, xxvi  
*Fungia*, Post-embryonic Development, 458  
 Fungus, New Frog-spawn, 729
- G.
- Gadeau de Kerville, H., Luminous Plants, 714  
*Gadina peruviana*, 329  
 Gärtner, F., New Gas-forming Bacillus, 387  
 Gain, E., Colouring Matters of Underground Organs, 77  
 — Influence of External Conditions on Growth, 85  
 Galapagos, Orthoptera, 55  
 Galatheidæ, 565  
 Galegeæ, Anatomy, 862  
 Galeodidæ, Lateral Eyes in, 447  
 Galeotti, G., Staining Living Cells, 755  
 Galippe, —, Presence of Microbes in Excretory Ducts of Normal Salivary Glands, 733  
 Gall-producing Copepod, 168, 283  
 Gallanol, Microbicidal Action of, 527  
 Galls, Structure and Composition, 586  
 Galtier, V., Influence of Bacterial Association, 726  
 Gamaleia, —, The Bacterial Poisons, 102  
 Gamble, F. W., Turbellaria of Liverpool Marine District, 454  
*Gammarus*, Shifting of Germinal Streak in, 195  
 Ganoids, Vertebral Column of, 324  
 Ganong, W. F., Absorption of Water by Green Parts of Plants, 592  
 Garstang, W., Bipinnariæ from English Channel, 207  
 — Phylogeny of Chordata, 438  
 Garszinsky, W. S., Can Cholera-spirilla survive the Winter? 614  
 Gas, Comparison between Petroleum, Auer Light and, with respect to their Usefulness for Photomicrographic Work, 627  
 — forming Bacillus, New, 387  
 — Incubator, Hearson's, 511

- Gas, Production by Bacteria, 384  
 Gases, Influence of Pressure on Growth, 85  
 Gasparini, G., *Actinomyces*, 604  
 Gastrodes, 575  
 Gastropoda. See CONTENTS, x  
*Gastropteron*, Genus, 180  
 Gastrulation in Chelonia, 664  
 Gault of Folkestone, Foraminifera, 153, 421, 540, 645, 763  
 Gaupp, E., Development of Hypophysis, 174  
 Gawronsky, N., Microbes in Normal Urethra of Women, 613  
 Gayon, U., Presence of Mannite in Wine, 373  
 'Gazelle,' Foraminifera of, 354  
*Gebia littoralis*, Development, 564  
 — — Embryology, 631  
 Gecko, Sarcosporidia of, 72  
 Gedoelst's Bacteriology for Veterinary Surgeons, 137  
 Gegenbaur, C., Phylogeny of Tongue, 662  
 Gelatin Cultures, Hearson's Incubator for, 514  
 — Duration of Incubation of Air and Water Micro-organisms on, 494  
 — Liquefaction by *Streptococcus pyogenes*, 727  
 — Nutrient, Method for Imparting Correct Reaction to, 270  
 — Plates, Method for Inoculating, 528  
 Gemmaria, Haacke's Theory of, 436, 551  
 Generations, Alternation in Insects, 558  
 Genital Apparatus of Hymenoptera, Male, 53  
 — Armature of Lepidoptera, Female, 332  
 — — — Male, 332  
 — — of Orthoptera, Female, 191  
 — Products in Polyclinidæ, 330  
 Geotropism and Epinasty, 370  
 Gérard, E., Presence in *Penicillium glaucum* of a Ferment which acts like Emulsion, 102  
 Germ-layer-formation in Stylommatophora, Cleavage and, 668  
 German Fishes, Cystic Worms of *Bothrioccephalus* in, 346  
 Germano, E., Differences between *B. typhosus* and Typhoid Bacilli, 388  
 Germany, Rabenhorst's Cryptogamic Flora, 596  
 Germicidal Properties of Human Mucus, 268  
 Germinal Area of *Mysis*, 57  
 — Layers, Formation in Insects, 557  
 — — of Arthropoda, 672  
 — Streak, Shifting in *Gammarus*, 195  
 Germination of Barley, Production of Saccharose in, 230  
 — Phanerogams. See CONTENTS, xxii  
 — Pollen-grains, 590  
 — *Ricinus*, 230  
 Germination of Uredineæ, 380  
 — Transformation of Reserve-substances during, 230  
 Ghon, —, Cultivating Gonococcus, 749  
 Ghriskey, A. A., Secondary Foci in Experimental Diphtheria, 610  
 Giacomini, C., Abnormal Human Embryo, 661  
 — Koristka Microscope, 620  
 Giard, A., Dimorphism due to Parasitism, 439  
 — New Phreocytes, 342  
 Gibbes, H., Demonstration of Psorosperms, 130  
 Gibelli, G., Cross- and Self-Pollination, 709  
 Gibson, R. J. H., Siliceous Deposit in *Selaginella*, 88  
 — Stem of *Selaginella*, 595  
 Giessler, R., Distribution of Oxalic Acid in Plants, 217  
 Gifford, J. W., Inexpensive Screen for Monochromatic Light, 141, 163  
 Gilchrist, J. D. F., Arrangement, Correlation, and Function of Pallial Organs of Tectibranchiata, 669  
 Gilg, E., Anatomy of *Afromendoncia* and *Mendoncia*, 221  
 Gill, C. H., the late, 264, 284  
 Gill-like Organs of *Sipunculus*, 683  
 — -pouches in Chelonia, Development, 38  
 Gilson, E., Crystallization of Cellulose and Chemical Structure of Cell-wall, 215  
 — G., Formation of Silk, 334  
 — Muscular Cells of *Ascaris*, 685  
 Giltay, E., Influence of Pollen on Fruit and Seed, 368  
 — Introduction to Study of Microscopy, 522  
 Girod, P., Kidney of Snail, 182  
 Gland, Histology of Mid-gut, 440  
 Glandular System of Ants, 444  
 Glass Receptacle for Series of Sections, 754  
*Globigerina*, Enclosure by *Orbulina*, 464  
*Glæothece linearis*, 17  
 Glossiphoniidæ, Efferent Canal, 683  
 Glycerin, Influence on Disinfectants, 608  
 Glycogen, Action of Yeasts, 721  
*Glyphopsis Bostoeki*, 301  
 — *coccinea*, 310  
 — *formicariæ*, 310, 314  
 — *lamellosa*, 309  
 — *splendida*, 309  
*Gnetum*, Embryology, 224  
*Gobius Capito*, Development of Head, 175  
 Godfrin, M. J., Resin-canals in *Abies pectinata*, 585  
 Goebel, K., Insectivorous Plants, 79  
 — Structure of Aquatic Plants, 585  
 — Vegetative Structure of Hepaticæ, 374  
 Göldi, E., Nematode of Coffee-disease, 452  
 Goethart, J. W. C., Drawing imperfectly visible Details with Camera Lucida, 408  
 Goette, A., Development of *Pelagia*, 69

- Goldfish Parasite, 699  
 Golenkin, M., Influence of Urticacæ and Moracæ, 472  
 Golgi's Method, Modification for Study of Human Brain, 533  
 — Silver Stain, Modification, 755  
 Gomout, M., *Actinococcus*, 376  
 — *Phormidium*, 241  
 Gonads of *Ancylus*, 668  
 Gonococcus, Cultivating, 749  
 — New Procedure for Staining, 534  
 Gonotome, Concerning, 176  
 Gordii, Notes on, 344  
 Gordiidae, Development of Organs, 684  
 Goronowitsch, N., Ectodermic Origin of Skeletal Rudiments, 35  
 — Ganglion Ridges in Head of Birds, 37  
 Goto, S., Canal of Laurer, 345  
 Gottschaldt, R., Synascidia of Spitzbergen Expedition, 671  
 Gottstein, A., Destruction of Peroxide of Hydrogen by Cells, with remarks on a Macroscopic Reaction for Bacteria, 102  
 Gould, L. J., Minute Structure of *Pelomyxa palustris*, 463  
 Graebner, P., Occasional Cleistogamy, 709  
 Graf, A., Excretory System of *Nepheleis*, 343  
 Graff, L., Notes on Land Phanerians, 686  
 Grafting, Cell-union in Herbaceous, 85  
 — Morphology and Physiology, 476  
 Granula, Fixing Methods, 758  
 Grape-must, Fermenting, with Pure-bred Yeasts, 235  
 Grasses, Aleurone-layer in Seed, 78  
 — Stem, 365  
 Grassi, B., Termite Societies, 190  
 Grawitz, E., Importance of Saliva and Sputum for the Biology of certain Bacteria, 614  
 Graziani, —, Physiology of *Penicillium Duclauxi*, 94  
 Great Salt Lake, *Artemia fertilis* from, 536  
 — — — Oolitic Sand from, 536  
 Green C. de B., Entomology of British Columbia, 328  
 Green, E. B., 763  
 — J. R., Germination of Pollen-grains, 590  
 Green Parasites, Nutrition, 711  
 Greenwood, M., Food-vacuoles of Infusoria, 353  
 — Rôle of Acid in Protozoan Digestion, 462  
 Gregarine in Algerian Acrididae, New, 212  
 — of *Lumbricus herculeus*, 577  
 Gregarines, New Genus of, 466  
 Grenfell, J. G., 287, 415  
 Grieg, J. A., Ophiuroids of North Sea, 67  
 Griffiths, A. B., Reproductive Organs of *Noctua pronuba*, 188  
 Grimaldia, Revivification, 716  
 Grimbert, —, Studies on the Bacillus of Eberth in Water, 733  
 Grimm, —, Protozoa in Abscess of Lung and Liver, 700  
*Gromia*, 418  
 Groom, P., Aleurone-layer in Seed of Grasses, 78  
 — Extra-floral Nectaries of *Aleurites*, 705  
 — T. T., Development of Cirripedia, 337, 403  
 Grove, E., Diatoms from Natal, 765  
 Growth of Phanerogams. See CONTENTS, xxii  
 Gruber, A., Microscopic Vivisection, 210  
 — M., Cholera Vibrio and Diagnosis of Cholera, 612  
 Gruvel, A., Buccal Apparatus of Cirripedia, 196  
 — Cirripedia, 450  
 Günther, C., Bacteriology, 137  
 — R. T., *Limnocooida tanganyicæ*, 460  
 — Minute Anatomy of *Limnocooidum*, 351  
 Guercio, G. Del, Parasitic Fungi, 723  
 Guérin, A., Origin of Doctrine of Microbes, 502  
 — C., Life-history of Mistletoe, 478  
 Guerne, J. de, Freshwater Medusa from Niger, 351  
 Gueynatz, —, Parasites of Sarcoma, 698  
 Guglielmo, G., New Exact and Easily Constructed Spherometer, 107  
 Guignard, L., Active Principles of Papayacæ, 468  
 — Development of Seed and its Integument, 81  
 — Localization of Active Principles in Capparidæ, Tropæoleæ, Limnantheæ and Resedacæ, 218  
 Guillebeau, A., Coccidium in Cattle, 577  
 Guinea, Gulf of, Entomotraca, 680  
*Gunnera*, Parasite, 725  
 Gurley, R. R., Classification of Myxosporidia, 465  
 Gut of Pig, Coarse and Fine Spirilla in, 731  
 Gymnosperms, Fertilization, 368  
 — Young Form, 471  
*Gymnosporangium*, Injuries produced by, 601

## H.

- Haacke, W., Origin of Mammals, 172  
 — Theory of Gemmaria, 436, 551  
 Haase, C., Mimicry, 52  
 Haberlandt, G., Nutrition of Viviparous Mangrove-plants, 591  
 Haecker, V., Generative and Embryonic Mitoses, 550  
 — Import of Chief Nucleolus, 178  
 — Winter and Summer Eggs of *Moïna*, 196  
 Hæmal Systems of Asteroidea, 574



- Hæmatokrit, New Method of separating  
White from Red Blood-corpuscles by  
means of, 278
- Hæmatoxylin, Formic Acid, 405
- Hæmatozoa in Animals, 358
- of Birds, 357
- Hæmin Crystals, Obtaining, 273
- Hair, Mammalian, Homologies and Origin,  
543
- Hairs, Achenial, of Compositæ, 367
- Laticiferous, of Cichoriaceæ, 223
- of *Tilia argentea*, 367
- Root-, 707
- — Parasitic Growths on, 763
- Haller, B., Neotænioglossæ, 46
- Notes on Polyplacophora, 670
- Halsted, B. D., Heliotropism of Mallow, 371
- Parasitic Fungi, 234
- *Plasmodiophora Brassicæ*, 490
- Hamaon, O., History of *Filaria uncinata*,  
64
- Schneider's Pore and Oesophageal  
Glands in Nematodes, 63
- Hamburger, H. J., New Bacterium of  
Lymph, 386
- Hammer, J. A., Plate Models of Embryonic  
Livers, 752
- Hampson, G. F., Indian Moths, 189
- Hanaušek, T. F., Thermogenous Bacteria  
as Cause of Inflammation, 503
- Hanitsch, R., Generic Nomenclature of  
Bowerbank's British Sponges, 576
- Hankin, E. H., Alexocytes, 243
- Bacteriological Observations in an  
Indian Dairy, 391
- Microbes in Soda-water, 391
- Hansemann, D., Specific Character of Cell-  
divisions, 326
- Stereoscopic Photomicrography, 393
- Hansen, A., Metastasis in Marine Algæ,  
483
- E. C., Aceto-bacteria, 384
- H. J., Morphology of Crustacean and  
Insect Appendages, 52
- Hansgirg, A., Movements of Flowers and  
Leaves, 229
- New Genera of Algæ, 233
- Oscillatoriaceæ, 241
- Red Colour of Perianth, 226
- Hardy, W. B., Changes induced by Urari  
in Wandering Cells of Frog, 178
- Structure and Functions of Alimentary  
Canal of *Daphnia*, 196
- Hargitt, C. W., *Perigonimus*, 351
- Hariot, P., Parasitic Fungi, 234
- Harmer, E. F., Collection of Microscopic  
Preparations, 760
- Harpacticidæ, 339
- Harris, T., Collecting and Preserving  
Urinary Sediment, 643
- Harrison, R. G., Development of Fins of  
Teleostei, 547
- Harslberger, J. W., Anatomy of Maize, 366
- Hartig, R., Characteristics of Duramen,  
218
- Parasitic Fungi, 379
- “Harvestmen,” Eyes, 335
- Harvey, J. J., Method for Mounting  
Opaque Objects, 539, 641
- Hassall, A., Adult Cestodes of Cattle,  
Sheep, and Allied Animals, 345
- Catalogue of Parasites, 667
- Hasse, C., Development of Vertebral  
Column, 176
- Vertebral Column of Ganoids, 324
- Haswell, W. A., Apparently New Type of  
Platyhelminth, 66
- Monograph of Temnocephalæ, 65
- *Polyercus*, 455
- Hatching of *Peripatus* Egg, 191
- -Ovens, Apparatus for Regulating Tem-  
perature, 122
- Hauser, G., Conservation of Bacterial Cul-  
tivations by means of Formalin, 130
- Haustoria of Phanerogamic Parasites, 82
- Hautefeuille, P., Wine Yeasts, 720
- Havet, J., Bactericidal Power of Dog's  
Blood and its Richness in Leucocytes,  
610
- Leucocytes and Bactericidal Power,  
492
- Hayeraft, J. B., Development of Wolffian  
Body in Chick and Rabbit, 36
- Head of Birds, Ganglion Ridges in, 37
- *Gobius Capito*, Development in, 175
- Selachian, Development, 548
- Hearson's Incubators, 511
- Heart of Orthoptera, 675
- of Spiders, Activity, 56
- Hectocotylization, Bilateral, in *Eledone  
cirrhosa*, 46
- Heda, V., Study of Mitosis, 751
- Hegler, R., Influence of Mechanical Trac-  
tion on Growth, 228
- Heiden, H., Anatomy of Combretaceæ, 221
- Ascidians of Minorca, 51
- Heidenhain, M., Nucleus and Protoplasm,  
44
- Heider, A., *Vibrio danubicus*, 247
- K., Gastrodes, 575
- Heim, F., *Aspergillus* developing in Sul-  
phate of Quinine, 380
- Cross- and Self-Pollination, 709
- L., Text-book of Bacteriological In-  
vestigation and Diagnosis, 503, 732
- On *Streptococcus longus pyothoracos*,  
733
- Heinig, R. L., Blind Root-suckers of  
Swamp Forest, 365
- Heinsen, E., Megaspore and Female Pro-  
thallium of *Selaginella*, 594, 632
- Helianthus tuberosus*, Tubers of, 83
- Heliopora cærulea*, 690
- Heliotropic Sensitiveness, 480
- Heliotropism, 480
- of Mallow, 371

- Heliozoon, New, 70  
*Helix*, Function of Kidney, 670  
 — *pomatia*, Examination of Tentacular Nerves of, 531  
 — Nerves of Oculiferous Tentacle of, 440  
 Helme, F., Classification of Microbes, 733  
 Helminthological Notes, 454, 570, 685  
 Helsingfors, Protozoa, 462  
 Hemipteron, Stridulating Aquatic, 194  
 Henking, H., *Hydrobia ulvæ*, 440  
 Henslow, G., Origin of Endogens, 87  
 — Self-adaptation of Plants to their Environment, 705  
 Hepaticæ, Elaters, 716  
 — New Genera, 482  
 — Vegetative Organs, 375  
 — Structure, 374  
 Herbst, A., Medullary Rays of Dicotyledonous Herbs and Shrubs, 470  
 — C., Experimental Embryology illustrated by Echinoderms, 346  
 Herculeis, J. Kunckel d'. See Kunckel d'Herculeis  
 Herdman, W. A., British Tunicata, 50  
 — Zoology of Irish Sea, 438  
 Herfort, K. V., Maturation of Ovum of Lamprey, 43  
 Hermann, F., Formalin as a Hardening and Preservative Medium, 135  
 Hermaphrodite Molluscs, Absence of Male Reproductive Organs, 46  
 Hermaphroditism in *Myzostoma*, Protandric, 456  
 Herpes Zoster. Protozoa in, 462  
 Herrick, F. H., Reproduction of Lobster, 677  
 Herrnheisser, J., Investigations on the Nutrient Value of Sterilized Vitreous Body for some Pathogenous Species of Bacteria, 733  
 Hertwig, O., Experimental Embryology, 171, 660  
 Herz, F. J., Bacteriology and Cheese-making, 503  
 Herzer, R., Fossil Fungi, 605  
 Hesse, R., Septal Glands of Oligochæta, 682  
 — Structure of Enchytræide, 201  
 — W., Gaseous Products of Bacteria, 102, 242  
 Hessert, W., Flagella-Staining without a Mordant, 756  
 Hest, J. J. van, Air Filter, 747  
*Heterakis Sossinoides*, 452  
*Heterodera radiciicola*, Symbiosis with Plants cultivated in Sahara, 477  
 Heterœcious Uredinæ, 722  
 Hewlett, R. T., Bacteriological Examination of Air, 629  
 — Cultivating Anaerobes in Agar, 630  
 — Cultivations of Tetanus Bacillus, 630  
 Hexactinellid Spicules, 352  
 Hexactinellids from Sagami Bay, New, 691  
 Heydrich, F., *Pleurostichidium*, a New Genus of Floridæ, 89  
 Heymons, R., Formation of Germinal Layers in Insects, 557  
 Hickson, S. J., Revision of Aleyonaria Stolonifera, 690  
 Hieronymus, G., Structure of Cells of Phycchromaceæ, 240  
 Hill, C., Epiphysis of Teleostean Fishes and of *Amia*, 546  
 — Study of Living Fish-embryos, 631  
 — J. P., *Balanoglossus* from New South Wales, 455  
 — *Polycercus*, 455  
 Hiltner, L., Fixation of Free Nitrogen by Leguminosæ, 479  
 Hirota, S., Sero-amniotic Connection and Fœtal Membranes of Chick, 663  
 Hirudineæ, Infundibular Apparatus, 62  
 — Jaws of, 62  
 — Notes on, 344  
 Histology of Vertebrates. See CONTENTS, vii  
 — Piersol's, 266  
 Hitchcock, A. S., Opening of Buds of Woody Plants, 222  
 Hoehstetter, F., Development of Abdominal Vein in Amphibia, 665  
 — Venous System of Mammals, 662  
 Hoffmann, C. K., Development of Selachian Head, 548  
 — Origin of Blood, 175  
 — Vascular System in Selachii, 42  
 — L., Dithion, a new Antiseptic, 281  
 Hohenauer, F., Stem of Grasses, 365  
 Holl, M., Maturation of Ovum in Mammals, 541  
 Holland, Cholera Vibrios of Epidemic in, 731  
 Holle, G., Anatomy of Leaves of Sapotaceæ, 223  
 Hollick, A., Fossil *Salvinias*, 595  
 Holm, J. C., Eifront's Process for Purification and Preservation of Yeast, 236  
 — J. F., Development of Olfactory Organ in Teleostei, 665  
 Holostomidæ, Life-history, 454  
 Holothurian Spicule, Development, 457  
 Holothurians of Naples, Parasites of, 45  
 — N. Atlantic, 207  
 Holtermann, C., Anatomy of Combretaceæ, 221  
 Homologies of some Articulatæ, 442  
 Honeysuckle, Double Leaves, 706  
 Hood, J., New Rotifers, 67  
 — Notes on Rotifers, 346  
 Hop, Pollination, 710  
 Horst, R., Earthworms from Congo, 343  
 Hosæus, H., Action of Yeasts on Glycogen, 721  
 — New Frog-spawn Fungus, 729

- Houlbert, C., Optical Properties of Wood, 519  
 — Secondary Wood of *Apetalæ*, 220  
 Howes, G. B., Systematic Position of Trilobites, 563  
 Hubbard, J. W., Yolk-nucleus in *Cymatogaster aggregatus*, 548  
 Huber, —, Cultivating Influenza Bacillus, 526  
 — J., Bulbils of *Chaetonema*, 599  
 — Classification of Lower Green Algæ, 597  
 — Development of *Pediastrum*, 599  
 — Epiphytic and Endophytic Chætophoraceæ, 90  
 Hubrecht, A. A. W., Morphology of Placenta, 541  
 — Placentation of Shrew, 321  
 Hünlein, F. H., Bacterial Studies in Tanning, 503  
 Human Beings, Pathogenic Action of *Bacillus pyocyaneus* on, 613  
 — Brain, Modification of Golgi's Method for, 533  
 — Embryo, Abnormal, 661  
 — — of Second Week, 35  
 — Liver Fluke, New, 454  
 — Mucus, Germicidal Properties, 268  
 — Organism, Effect of Sunlight on, 607  
 — Tape-worm, New, 687  
 Humphrey, J. E., Botanical Micro-technique, 523  
 — Nucleoles and Centrosomes, 583  
 Hungary, Bryozoa, 442  
 Hyalonematidæ, Revision, 70  
 Hybridism in Cucurbitaceæ, 475  
*Hydractinia*, Origin of Sex-cells in, 576  
*Hydrobia ulvæ*, 440  
 Hydrogen Sulphide, Microbes which evolve, 492  
 — Sulphuretted, Formation by Aerobic Bacteria, 607  
 — — generated by Bacteria, Demonstrating, 530  
 Hydroida, Irish, 208  
 Hydroids, Australian, 209  
 — Budding, 691  
 — of 'Albatross,' 351  
*Hymenogaster*, Parasitic, 724  
 Hymenomyces, Nuclear Division, 380  
 Hymenoptera, Copulatory Organs of Male, 53  
 — Male Genital Apparatus, 53  
 — Poison-apparatus, 445  
 — Salivary Glands, 189  
 — Tracheal System of Larval, 334  
 Hypermetamorphosis of Cantharidinæ, 334  
 Hypnæ of Autobasidiomycetes, Vascular, 724  
 Hypophysis Cerebri, Development in Cat, 35  
 — Development, 174  
 Hypophysis, Relations in Birds of Notochord and, 544  
 — Development in Teleostei and Amphibia, 665
- I.
- Iberian Peninsula, Leeches, 343  
 Icacinaceæ, 79  
 Ice Crystals, Photomicrograms, 741  
 Ichneumonidæ, Salivary Glands, 445  
 Iguana, Development of Teeth, 38  
 Ihering, H. von, Morphology of *Sacoglossa*, 180  
 — *Pellella*, 556  
 — R. v., Fall of Leaves, 366  
 Iijima, I., New Human Tape-worm, 687  
 — — Hexactinellids from Sagami Bay, 691  
 Ilkewitsch, K., New Method for Detecting Tubercle Bacilli in Phthisical Sputum, 402  
 Ilkewicz, W., Nuclei of Anthrax Spores, 385, 406  
 Illuminating Apparatus. *See* CONTENTS, xxxi  
 Illumination for Photomicrographical Purposes, New Method of, 261  
 Imbedding Objects. *See* CONTENTS, xxxiv  
 Imhof, O. E., Alpine Rotifers, 67  
 Immunity, Acquired, to *Pneumococcus*, 99  
 — to Diphtheria, 727  
 Incandescent Light, Auer, Comparison between Petroleum, Gas, and with Respect to their Usefulness for Photomicrographic Work, 627  
 Incubator for any Source of Heat, 516  
 Incubators, Hearson's, 511  
 Index to Foraminifera, 354  
 — 'Zoologischer Anzeiger,' 49  
 Indian Archipelago, Terrestrial Fauna of East, 552  
 — Deep-sea Mollusca, 668  
 — Echinoderms, Illustrations of, 689  
 — Moths, 189  
 — Ocean, Deep-sea Invertebrates, 439  
 Indican, 469  
 Infection, Double Coccidian, 696  
 — Mixed, from Tubercle Bacilli and Pyogenic Cocci, 248  
 Inflorescence of Urticaceæ and Moraceæ, 472  
 Influenza Bacillus, Cultivating, 526  
 — — Demonstration, 640  
 — — Egg-yolk Medium for Cultivating, 269  
 — — Pfeiffer's, 100  
 Infundibular Apparatus of Hirudinea, 62  
 Infusoria, Food-vacuoles, 353  
 — of Diarrhœa, 463  
 Infusorian Pathogenic to Pigeons, 211  
 Infusorians, So-called Excretory Granules of, 352



- Ingenitzky, J., Copulatory Organs of Li-  
bellulida, 53  
Inheritance of Acquired Characters, 176  
Inghilleri, —, Bujwid Reaction and  
Bouillon Cultivations, 525  
— Differences between *B. coli commune*  
and *B. typhosus*, 612  
— Quick Double-staining Method for Ex-  
amination of Blood and Tissues, 639  
Ingpen, J. E., 146  
Inhibition in Cephalopoda, 45  
Injecting Objects. See CONTENTS, xxxv  
Injection, Natural, 641  
Insect Appendages, Morphology, 52  
Insecta. See CONTENTS, xi  
Insectivorous Habit of *Dionaea*, 231  
— Plants, 79  
— — Pitchered, 364  
Instincts of Common English Spiders, 55  
Intramolecular Respiration, 87  
Inulin and its Allies, 217  
Inventions, Patents for, 120  
Iridæ, Leaves, 222  
Irish Earthworms, New, 62  
— Hydroida, 208  
— Polyzoa, New and Rare, 185  
— Pycnogonida, 562  
— Sea, Zoology, 438  
Irritability of Phanerogams. See CON-  
TENTS, xxiii  
— of Spermatozoids of Fucaeæ, 599  
Ishikawa, C., Nuclear Division in *Nocti-  
luca*, 464  
— Reproduction of *Noctiluca miliaris*, 693  
*Isopyrum*, Root-tubercles, 587  
Isotropous, Relations to Anisotropous  
Layers in Striped Muscles, 437  
Issieff, B., Acquired Immunity to *Pneu-  
mococcus*, 99  
Istvánfi, J., Meteoric Paper, 89  
— Parasitic Fungi, 601  
Italy, *Ligula* as Food in, 573  
Itzerott, G., Bacteriology; Brief Guide for  
Students and Physicians, 614  
Iulidæ, Classification, 675  
— Developmental Stages, 335  
Ivanoff, M., New Cholera-like Species of  
*Vibrio*, 391, 498  
Iwanowskij, D., Influence of Oxygen on  
Alcoholic Fermentation, 594
- J.
- Jaccard, P., Embryology of *Ephedra*, 708  
— Influence of Pressure of Gases on  
Growth, 85  
Jack, J. B., New Genera of Hepaticæ, 482  
— J. G., Fructification of *Juniperus*, 363  
Jackson, G. T., The Barber Shop as a  
Source of Contagion, 614  
Jaczewski, A. de, Classification of Pyreno-  
mycetes, 601  
Jägerskiöld, I. A., Anatomy of Nema-  
todes, 202  
— Structure of Nematodes, 452  
Jahn, E., Wood and Pith at the Bounds of  
the Annual Growth, 704  
Jaisohn, P., Staining Spores, 276  
Jakowski, M., Mixed Infection from Tu-  
bercle Bacilli and Pyogenic Cocci, 248  
James, J. F., *Fucoides*, 600  
Jamieson, T., Root-hairs, 707  
Janczewski, A. de, Parasitic Fungi, 234  
— Polymorphism of *Cladosporium her-  
barum*, 94  
— Position of *Pompholyx*, 381  
Janet, C., Antennary Nerves and Chord-  
otonal Organs in Ants, 334  
— Glandular System of Ants, 444  
— Nematodes of Pharyngeal Glands of  
Ants, 64  
— Production of Sound by Ants, 334  
Janson, —, *Filaria immitis* in a Japanese  
Wolf, 65  
Japanese Butterflies, Seasonable Dimorph-  
ism and Polymorphism in, 444  
— Wolf, *Filaria immitis* in, 65  
Jaw, Amœbæ in Abscess of, 72  
Jaworowski, A., Development of Pulmo-  
nary Sacs in Arachnids, 561  
Jaws of Hirudinea, 62  
Jelinek, O., Use of Stabilite for Celloidin  
Preparations, 753  
Jelliffe, S. E., Organisms in Chicago  
Water Supply, 328  
Jennings, H. S., Rotatoria of Michigan,  
574  
Jessner, —, Fungi of *Favus*, 605  
Jönsson, B., Influence of Light on Germi-  
nation of Seeds, 590  
— Parasite of *Gunnera*, 725  
— Respiration and Assimilation, 715  
— Internal Bleeding of Plants, 87  
Jørgensen, A., Effront's Process for Purifi-  
cation and Preservation of Yeast, 235  
Johansen, H., Development of Compound  
Eye of *Vanessa*, 186  
Johne, —, Morphology of Anthrax Bacilli,  
102  
— — of Bacillus of Splenic Fever, 391  
Johns Hopkins University, New Machine  
for Cutting Thin Sections of Rocks and  
Minerals, 533  
Johnson, H. P., Plastogamy of *Actino-  
sphaerium*, 577  
— L. N., Zoospores of *Draparnaldia*, 91  
— T., New Parasitic Alga, 717  
— Systematic Position of Bangiaceæ, 599  
Joly, J., Bright Colour of Alpine Flowers,  
705  
Jones, A. C., Fungus found in Phthical  
Cavities and Sputa, 97  
Just, L., Relationship between Leaf-devel-  
opment and Formation of Vessels, 77  
Joubin, L., Cephalopoda of Amboina, 554



- Joubin, L., French Nemertinea, 571  
 Juel, O., Mechanism of Flowers of *Schizanthus*, 712  
 Julien, A. A., Preparing and Staining Cover-glass Preparations, 403  
*Juncus bufonius*, Pseudo-vivipary, 477  
 Jungersen, H. F. E., Development of Kidneys in *Amia calva*, 546  
 — — — in Sturgeon, 325  
 Jungner, J. R., Adaptation of Fruits to Climate, 706  
*Juniperus*, Fructification, 363  
 Jurányi, L., Fertilization of Gymnosperms, 368
- K.
- Kahane, M., Living Parasites in Blood of Cancerous Persons, 580  
 Kahliden, von, Microscopical Technique, 137  
 Kaiser, J. E., Acanthocephala, 65  
 Kaisin, A., Bactericidal Power of Blood, 98  
 Kanthack, A. A., Recent Researches on Saccharomycetes, 488  
 Kantorowicz, —, Use of Thionin, 405  
 Karg, K., Photomicrograms for Purposes of Instruction, 394  
 Karop, G. C., 283  
 Karpelles, L., Anatomy of *Bdella arenaria*, 57  
 Karsten, G., Embryology of *Gnetum*, 224  
 — Nucleoles and Centrosomes in *Psilotum*, 360  
 Karyoid, 717  
 Karyokinesis, 467  
 — Behaviour of Nucleoles during, 583  
 — — of Pigment-granules during, 44  
 — in Pollen Mother-cells of *Larix*, 74  
 Karyokinetic Phenomena in Cells of Blastoderm of Teleosteans, 41  
 Kayser, G., Development of Seed, 80  
 — Nucellus of Ovule of *Croton*, 368  
 Kedrowski, W., On two new Species of Bacteria which produce Butyric Acid, 614  
 Keibel, F., Small Auxiliary Apparatus for the Plate Modelling Method, 752  
 Keller, J., Asexual Reproduction in Fresh-water Turbellaria, 685  
 Kellermann, —, Short Studies in Bacteriology, 391  
 Keng, L. B., Changes induced by Urari in Wandering Cells of Frog, 178  
 Kerry, R. E., New Pathogenic Anaerobic Bacillus, 503  
 Kerville. See Gadeau de Kerville  
 Keuten, —, Nuclear Division in *Euglena*, 577  
 Khmelevsky, P. A., Influence of Light on Pyogenic Microbes, 492  
 Kidney of *Amia calva*, Development, 546  
 Kidney of *Helix*, Function, 670  
 — Snail, 182  
 — Sturgeon, Development in, 325  
 Kiessling, F., General Report on *Bacterium coli commune*, 102  
 — *Vibrio* resembling Cholera Bacillus, 247  
 Kinscherf, —, Spore-staining after Maceration, 757  
 Kingsley, J. S., Classification of Arthropoda, 331  
 Kirchner, M., Berkefeld Filter, 267  
*Kirchneriella obesa*, 16  
 Kirkby, W. F., Bees and Dead Carcasses, 444  
 Kishinouye, K., Cœlomic Cavity of Spider, 676  
 — Development of Holothurian Spicule, 457  
 — Eyes of *Cardium muticum*, 671  
 Kitt's (T.) Bacteriology and Pathological Microscopy, 137  
 Kjellman, F. R., *Acrosiphonia*, 484  
 — *Laminaria*, 484  
 Klaatsch, H., Origin of Scleroblasts, 661  
 — Vertebral Column of Fishes, 41  
 Klebahn, H., Heterœcious Uredineæ, 722  
 — New Genera of Algæ, 233  
 Klebs, G., Influence of Light on Propagation of Plants, 227  
 Klecki, V. von, Micro-organisms of Rancid Butter, 496  
 Klein, E., Intracellular Bacterial Poisons, 495  
 — Morphology of Bacteria, 491  
 — J., Structure of Flower of Cruciferae, 472  
 Klemm, P., Aggregation of Protoplasm, 359  
 — Rejuvenescence in Siphonæ, 485  
 — Structure of *Caulerpa*, 376  
 Klercker's Arrangement improved for Cultivation of Living Organisms under Microscope, 396  
 Klercker, J. af, Movements of Flowers of *Veronica*, 229  
 Klett, F. P., Development and Present Standpoint of Bacteriology, 391  
 Knees of *Taxodium distichum*, 365  
 Knife, New Double, 403  
 Knipowitsch, N., Ascothoracida, 197  
 Knoblauch, O., Investigations on Bacteria of Rhine above and below Cologne, 102  
 Knoll, P., Muscle-Fibres of Mollusca, 49  
 Knorr, R., On the Identity of *Streptococcus pyogenes* and *S. erysipelatis*, 102  
 Knower, H. McE., Origin of "Nasutus" (Soldier) of *Eutermes*, 560  
 — Pteropods with two Separate Sexual Orifices, 555  
 Knowlton, F., Fossil Chara, 717  
 Knuth, P., Cross-pollination and Self-pollination, 589, 709

- Kny, L., Formation of Folds in Cell-walls, 216  
 — Laticiferous Hairs of Cichoriaceæ, 223  
 — Physiological Function of Anthocyan, 228
- Koch, A., Action of Yeasts on Glycogen, 721  
 — Apparatus for Regulating Temperature of Hatching-ovens, 122  
 — New Frog-spawn Fungus, 729  
 — G. v., Asexual Reproduction of *Madrepora*, 457  
 — L., Vegetative Branching, 364
- Kochs, W., Is there a Cell-life without Micro-organisms, 551
- Köhler, A., New Method of Illumination for Photomicrographical Purposes, 261  
 — *Siphonaria*, 47  
 — E., Valvular Apparatus in Excretory Vessels of *Tænia*, 454
- Koehler, R., Growth of Blastoderm in Teleosteans, 40  
 — Karyokinetic Phenomena in Cells of Blastoderm of Teleosteans, 41
- König, A., Larva of *Oncodes*, 675
- Körber, B., Distribution of Bacteria Colonies in Esmarch's Roll Tubes, 529
- Kofoid, C. A., Laws of Cleavage in *Limax*, 555
- Kolle, —, Experimental Cholera Studies on Guinea-pigs, 614
- Koristka Camera Lucida, 623  
 — Microscopes, 616  
 — Microtomes, 633  
 — Photomicrographic Cameras, 623  
 — Semi-Apochromatic 1/15 Objective, 737
- Korschelt, E., Development of *Ophryotrocha*, 341  
 — Spawn and Embryos of *Eledone*, 555
- Kossel, —, Pathogenic Action of *Bacillus pyocyaneus* on Human Beings, 613  
 — A., Disruption Products of Nuclein Acid, 552  
 — H., Action of Nuclein Acid on Bacteria, 607
- Kossowitsch, P., Apparatus for Pure Cultivation of Algae, 744  
 — Fixation of Free Nitrogen by Algae, 592
- Kowalevsky, A., Heart of Orthoptera, 675
- Krabbe, G., Relation between Tension and Growth in Length, 369
- Král, —, Cultivating Gonococcus, 749
- Kristelli, R. S. v., Pigment of Aril, 469
- Kruchmann, C., Making and Preserving Specimens of Bacteria for Museum Purposes, 531
- Krüger, P., Perfume of Violet, 231
- Krüß, H., Colorimeter with Lummer-Brodhun Prism Pair, 740
- Kruger, F., Parasitic Fungi, 722
- Kruse, W., Critical and Experimental Contributions to the Hygiene of Water, 614  
 — Method for Inoculating Gelatin Plates, 528
- Kükenthal, W., Dentition of Pinnipedia, 36
- Künckel d'Herculeais, J., Diptera Parasitic on Acrididæ, 446, 560  
 — Hypermetamorphosis of Cantharidinæ, 334  
 — Oviposition of Acrididæ, 560
- Küstenmacher, M., Structure and Composition of Galls, 586
- Kütke, F. P., Development and Present Standpoint of Bacteriology, 614
- Kützing, T. F., The late, 118
- Kuprianow, J., Immunity to Diphtheria, 727  
 — Obtaining Germ-free Blood-serum, 400  
 — Vibrios and Production of Lactic Acid, 494
- Kurimoto, T., New Human Tape-worm, 687
- Kurloff, M., Parasite of Skin Cancer, 355
- Kuster's (M.) Hollow Spheres for Microscopic Objects, 135
- Kutscher, —, Absence of Phosphorescence in Cholera Cultures, 399

## L.

- Labbé, A., Double Coccidian Infection, 696  
 — Study of Endoglobular Parasites, 632
- Laboulbeniaceæ, 95
- Lacaze-Duthiers, H. de, Ascothoracida, 198  
 — *Flabellum anthophyllum*, 457  
 — Gonads of *Ancyclus*, 668
- Lacour-Eymard, —, Chamberland Filter Système André, 529
- Lactic Ferment, Relations with *B. lactis aerogenes* and *B. typhosus*, 245  
 — Acid, Vibrios and Production of, 494
- Lactomyces inflans caseigrana*, 603
- Lacustrine Plankton, Distribution, 552
- Lafar, F., Acetic Acid-forming Blastomycete, 236  
 — Counting Apparatus specially adapted for Petri's Capsules, 393
- Lagenidium*, 377
- Lagerheim, G. v., Snow-flora of Spitzbergen, 605
- Lamellibranchiata. See CONTENTS, xi
- Laminaria*, 484
- Laminariaceæ, 90
- Lamp Chimney, 108  
 — Petroleum, Working with Hearson's Incubator, 513  
 — Clay Wick for, 737
- Lamprey, Maturation of Ovum, 43
- Lampyridæ, Comparative Morphology of Abdomen of, 673
- Lance, D., Revival of Tardigrades, 335
- Land Mollusca, Growth Changes of Radula, 182

- Land Planarians from Tasmania and South Australia, 202  
 — — Notes, 686
- Landel, G., Influence of Solar Rays on Growth, 84
- Landmann, —, *Streptococcus longus* in Drinking-Water, 100
- Lang, A., Budding of Hydroids, 691
- Langer, A., Development of Bulbus Cordis in Amphibians and Reptiles, 664
- Lankester, E. R., Reappearance of *Limnocoedium Sowerbii*, 69
- Lantern, Triple Rotating Electric, 410
- Lanz, —, New Procedure for Staining Gonococcus, 534
- Lapine, N., Parasitic Fungi, 378
- Larix, Karyokinesis in Pollen-mother-cells, 74
- Larva of *Oncodes*, 675
- Larvæ, Colours of Lepidopterous, 188  
 — of *Balanoglossus*, 204, 631  
 — of British Fishes, 665  
 — of *Melolontha*, Stigmata, 54  
 — of *Smerinthus populi*, Sexes of, 188
- Larval Hymenoptera, Tracheal System, 334
- Laser, H., Apparatus for Boiling and Cooling Water, 267  
 — Bacillus of Mouse-disease, 390  
 — Effect of Citric Acid on Diphtheria Bacillus, 728
- Latapie, A., Fixing-board for Experiments on Animals, 760
- Laurent, E., Assimilation of Free Nitrogen by Plants, 86
- Laurer, Canal, 345
- Laurie, M., Anatomy and Relations of Eurypteridæ, 192
- Lauterborn, R., Movements of Diatoms, 606  
 — Rotifers of the Rhine, 67  
 — Structure and Cell-division of Diatoms, 239  
 — Winter Fauna of Upper Rhine, 440
- Leaf-development, Relationship between Formation of Vessels and, 77  
 — movement in *Cereis*, 712  
 — of Butomaceæ, 366  
 — stalk of *Atragene*, Swellings on, 473
- Leaves, Accumulation of Carbohydrates in, 217  
 — Comparative Anatomy, 222  
 — Fall, 366  
 — Movements, 229  
 — of Conifers, Size, 472  
 — of Honeysuckle, Double, 706  
 — of Irideæ, 222  
 — of Nymphaeaceæ, 366  
 — of *Physotium*, 375  
 — Protection against Excessive Rainfall, 82  
 — Radiation and Absorption of Heat, 373  
 — Respiration of Green and Etiolated, 371
- Leche, W., Dentition of Mammals, 173  
 — Development of Teeth in Iguana, 38
- Leclaf, J., Sporicidal Action of Serum, 728
- Leclerc du Sablon, —, Anatomy of Stem of *Wistaria sinensis*, 363  
 — Germination of *Ricinus*, 230
- Lecomte, H., Amount of Water Absorbed by Roots, 711  
 — Root-tubercles of *Arachis*, 707
- Lee, A. B., Microtometist's Vade Mecum, 120
- Leech, Eye, 683  
 — like Parasites of American Crayfish, 343
- Leeches of Iberian Peninsula, 343
- Lefevre, G., Vertebraation of Tail of Appendiculariæ, 557
- Léger, L., New Genus of Gregarines, 466  
 — Gregarine in Algerian Acrididæ, 212  
 — Nuclei of Mucorini, 486  
 — Sexual Reproduction in Fungi, 486  
 — Structure of Nucleus in Mucorini, 701
- Legrain, E., Symbiosis of *Heterodera radicola* with Plants cultivated in Sahara, 477
- Legs, Thoracic, of *Triarthrus*, 198
- Leguminosæ, Fixation of Free Nitrogen, 479  
 — Root-tubercles, 586, 707
- Lehmann, K. B., *Bacillus levans*, 500
- Leitz's Mechanical Stage, 105  
 — Micrometer Screw Adjustment, 109  
 — Microscope, 103  
 — Microtome, 131  
 — Photomicrographic Apparatus, 109
- Lemaire, A., Microscopical Preparations of Algæ, 277  
 — Two new Staining Reagents for Meristems, 533
- Lemardeley's Photographic Microscope, 518
- Lendenfeld, R. von, Haacke's Theory of Gemmaria, 436  
 — Systematic Position of *Placospongia*, 210
- Lenhossek, —. v., Nerve-cord of Rays, 326
- Lens Mirrors, Construction of Silvered, 254
- Lenses, Chromatic Aberration, 116
- Lenti, P., Influence of Alcohol, Glycerin, and Olive Oil on Disinfectants, 608
- Leo, H., Biology of Cholera-bacilli, 614
- Lepadidæ, Post-embryonic Development, 338
- Lepidoptera, Androconia, 186  
 — Female Genital Armature, 332  
 — Male Genital Armature, 332  
 — Micro-, Notes, 443  
 — Pigmentation in Scales, 186  
 — Relations between Colouring and Habit, 558

- Lepidoptera, Temperature Experiments, 673  
 Lepidopterous Larvæ, Colours, 188  
*Lepidostrobos*, Structure, 88  
 Leprosy Bacilli, Simultaneous Double Stain for, 277  
*Leptothrix racemosa*, 726  
 Lermoyez, —, Germicidal Properties of Human Mucus, 268  
 Lesage, P., Influence of Tension of Aqueous Vapour on Growth of Fungi, 717  
 — Palisade-cells and Transpiration, 470  
 Letellier, A., Growth of Root, 85  
 Letulle, —, Staining Tubercle Bacilli, 640  
 Leuckart, R., Infundibular Apparatus of Hirudinea, 62  
 Leucocytes and Bactericidal Power, 492  
 — Dog's Blood, its Richness in, 610  
 Levander, K. M., Chain-forming Peridium, 580  
 — *Pedalion*, 574  
 — Protozoa of Helsingfors, 462  
 Levy, —, Presence of *Diplococcus pneumoniae* and *Streptococcus pyogenes* in Osteomyelitis and Periostitis, 245  
 Lewis, R. T., 286, 762  
 Libellulidæ, Copulatory Organs, 53  
 Lichens, British, 488  
 — Fungus which forms several Different, 237  
 — New Substance extracted from, 488  
 — Structure, 487  
 Liverworts, Relations of Nucleus to Spore-formation in, 232  
*Lieberkuhnia*, 418  
 Liebscher, G., Assimilation of Nitrogen by Plants, 478  
 Life-history of Bombycine Moths, 187  
 — — — of Foraminifera, 694  
 — — — of Holostomidæ, 454  
 — — — of Mistletoe, 478  
 — — — of Tænias, 203  
 Life of Amœbæ, 694  
 Light, Action on Bacteria, 241  
 — and Colour Sensations, Measurement, 119  
 — Chemical Intensity of, Influence on Growth of Plants, 475  
 — Influence on Flowers, 227  
 — — on Germination of Seeds, 590  
 — — on Propagation of Plants, 227  
 — — on Pyogenic Microbes, 492  
 — — on Respiration, 713  
 — — on Striation of Diatoms, 491  
 — Monochromatic, New Screen for, 141, 163  
 — — of any desired Wave-length, Instrument for producing, 394  
 — Sense, in Eycless Bivalves, 441  
 Lignier, O., Employment of Vesuvium for Fossil Plants, 133  
 — Fruit of *Bennettites*, 363  
 — Venation of *Cycas*, 223  
 Lignification, Firmness, and Elasticity in Cell-walls, Connection between, 469  
 — Influence on Life of Cell, 218  
*Ligula* as Food in Italy, 573  
 Liliacæ, Arborescent, Root of, 221  
 — Development of Elaioplasts, 467  
 Lilienfeld, L., Selective Power of Cells in Absorption of Pigments, 276  
*Lilium Martagon*, Nuclear Division in Pollen-mother-cells, 74  
*Limax*, Laws of Cleavage, 555  
 — *maximus*, Examination of Eggs, 531  
 Limnantheæ, Localization of Active Principles in, 218  
*Limnocyclus tanqanyicæ*, 460  
*Limnocodium*, Minute Anatomy, 351  
 — *Sowerbii*, Reappearance, 69  
*Limulus*, Artificial Segmentation, 336  
 — Structures resembling Dermal Bones, 448  
 Lindau, G., Systematic Position of *Ditiola*, 723  
 Lindet, L., Production of Saccharose in Germination of Barley, 230  
 Lindner, P., Morbific Effect of certain Vorticellæ, 692  
 — Parasitic Vorticellæ, 211  
 — *Schizosaccharomyces pombe* sp. n., New Ferment-producer, 391  
*Lingulina nodosaria*, 153  
 — *seniornata*, 154  
 Linsbauer, L., Stipules of *Euonymus*, 366  
 Linstow, —, v., Helminthological Notes, 454  
 — *Heterakis Sossinoi*, 452  
 — Structure and Life-history of Tænias, 203  
 Lister, J. J., Life-history of Foraminifera, 694  
 Lithodinæ, Conversion of Pagurinæ into, 678  
 Liver Fluke, New Human, 454  
 — Investigating Histology of Vertebrate, 129  
 — Protozoa in Abscess, 700  
 Liverpool Bay, Copepoda, 450  
 — Marine District, Turbellaria, 454  
 — Microscopical Society, 264  
 Livers, Plate Models of Embryonic, 752  
 Lobeliaceæ, Vernation in, 222  
 Lobster, Histology of Nervous System of Embryonic, 563  
 — Reproduction, 677  
 Locard, —, Mollusca of Water Mains of Paris, 182  
*Locusta*, Tracheal System, 446  
 Locusts, Dipterous Parasites, 446  
 — Flight, 445  
 Locy, W. A., Derivation of Pincal Eye, 176  
 — Segmentation in Medullary Folds and Embryonic Rim, 543  
 Loeb, J., Cerebral Physiology of Worms, 681



- Loeb, J., Simple Method for producing two or more Embryos from one Egg, 630
- Lömberg, E., Blind *Cambarus* from Florida, 450
- Loew, O., Alkaline Reaction of Aquatic Plants, 372
- Loewenberg, —, Microbe of Ozæna, 501
- Lomisinae, 566
- Looss, A., Monograph on *Distomum*, 687
- Loranthaceæ, Root of Parasitic, 473
- Lorch, W., Anatomy of Mosses, 596
- Loriol, P. de, Echinoderms of Bay of Amboyna, 349
- Ophiuroids of Mauritius, 349
- Lothelier, S., Spiny Plants, 222
- Lotsy, J. B., Assimilation of Nitrogen by Plants, 478
- Knees of *Taxodium distichum*, 365
- Lovibond, J. W., Measurement of Light and Colour Sensations, 119
- New Coloured Screens, 138
- Lubinski, W., Apparatus for Anaerobic Cultivations, 628
- Lucas, R., Mouth-parts of Trichoptera, 54
- Lucernaria of Port Erin, 460
- Ludwig, F., Fungus Flux of Trees, 604
- Parasitic Fungi, 93
- H., Asteroidea, 689
- Lühe, M., Anatomy of Tæniidæ, 572
- Lütkenmüller, J., Chlorophores of *Spirotænia obscura*, 90
- Pores of Desmidiaceæ, 484
- Lumbricidæ, Revision, 683
- Lumbricus herculeus*, Gregarine of, 577
- Luminous Organs and Compound Eyes, 336
- Lummer-Brodhun Prism Pair, Colorimeter with, 740
- Lundborg, H., Development of Hypophysis and Saccus vasculosus in Teleostei and Amphibia, 665
- Lung, Protozoa in Abscess of, 700
- Technique for Studying Tubercle Bacilli in, 401
- Lungs of Spiders, Development, 676
- Lunkewicz, M., Cold Stage, 266
- Quadrangular Culture-Capsules, 266
- Lunkewitsch, M., *B. typhi murium* and Caucasian Field Mice, 613
- Lustig, A., Pacini's Preserving Fluid, 758
- Lutz, A., *Tænia nana* and *T. flavopunctata*, 687
- Lycopodiinæ, Sporophyte of, 88
- Lymnaeus*, Primitive Nephridia of, 556
- Lymph, New Bacterium of, 386
- M.
- Maas, O., Craspedote Medusæ of Plankton, 575
- Development of Cornacuspongia, 209
- Maassen, A., Blood Serum as Diagnostic Cultivation Medium for Cholera Vibrio, 269
- Maassen, A., Formation of Sulphuretted Hydrogen and Mercaptan by Aerobic Bacteria, 607
- Non-Albuminous Cultivation Media for Vibrios, 525
- MacBride, E. W., Organogeny of *Asterina gibbosa*, 206
- McBride, T. H., New Myxomycetes, 490
- Macchiati, L., *Streptococcus Bombycis* and Silkworm Disease, 243
- McDougal, D. T., Intertwining of Tendrils, 371
- Root-tubercles of *Isopyrum*, 587
- W., Structure and Functions of Alimentary Canal of *Daphnia*, 196
- Maceration, Spore-staining after, 757
- Macfarlane, J. M., Irrito-contractility, 593
- Pitchered Insectivorous Plants, 364
- Mach, E., Fermenting Grape- and Apple-must with Pure-bred Yeasts, 235
- McIntosh, W. C., Ova and Larvæ of British Fishes, 665
- Structure of *Euphrosyne*, 450
- Tubes formed by Annelids, 198
- Young Stages of *Magelona*, 451
- McLeod, J., Cross-Pollination and Self-Pollination, 226
- Macmillan, C., Archenema, Protonema, and Metanema, 481
- McWeeney, E. J., Demonstration of Typhoid Bacillus in suspected Drinking Water by Parietti's Method, 614
- Madrepora*, Asexual Reproduction, 457
- Madura Foot Parasite, 390
- Maffucci, —, Researches on the Toxic Products of Bacillus of Tuberculosis, 733
- Magelona*, Young Stages, 451
- Magnetism, Action on Germination, 590
- Magnifier for Reading Small Print, 739
- Magnoliaceæ, Anatomy, 78
- Magnus, P., Parasitic Fungi, 489, 601
- Puccinias Parasitic on Compositæ, 238
- Maier, B. L., Eye of *Clepsine*, 62
- Maize, Anatomy, 366
- Maksutoff, —, Phagocytosis and Actinomycosis, 611
- Malachiidæ, Comparative Morphology of Abdomen of, 673
- Malaquin, A., Researches on Syllideæ, 60
- Malaria Parasites, Influence of Cold on Vitality of, 357
- — of Summer and Autumn Fevers, Structure, 700
- Structure of Nucleus of Crescentiform Bodies of, 466
- Malay Archipelago, Crustacea of, 563
- Malformations produced by *Cystopus candidus* and *Ræstelia cancellata*, 234
- Malinesco, O., *Scenedesmus*, 382
- Structure of Cells of Phycchromaceæ, 241
- Maljean, —, Bacteriological Study of Water of town of Châlons-sur-Marne, 504

- Mall, F., Human Embryo of Second Week, 35
- Mallock, A., Insect Sight and the Defining Power of Composite Eyes, 443
- Mallow, Heliotropism, 371
- Mally, F. W., Combination Hot Filter and Steam Sterilizer, 529
- Malta Fever, Ætiology, 500
- Malvoz, E., Presence of *B. coli commune* and *B. typhosus* in Drinking Water, 99
- Mammalian Hair, Homologies and Origin, 543
- Teeth, Succession and Genesis, 542
- Mammals, Dentition, 173
- Development of Müllerian Duct, 322
- — of Venous System, 662
- Maturation of Ovum, 541
- Origin, 172
- Man, Ringworm in, 97
- Mangin, L., Composition of Cell-wall of Fungi, 233
- Muciferous and Resiniferous Cells in Yew, 586
- Mucilage-layer in Flax-Seeds, 78
- Pectic Substances in Tissues, 75
- Structure of Cell-wall, 467
- Mangrove-plants, Nutrition of Viviparous, 591
- Mannite, Presence in Wine, 373
- Mantle, Formation of, 50
- Marattia, Development, 88, 481
- Marcacci, A., Formation and Transformation of Carbohydrates, 713
- Marchal, E., *Bacillus mycoides* and Nitrification, 98
- P., Diptera destructive of Cereals, 675
- Fertile Workers among Bees, 674
- Reproduction of Wasps, 190
- Seminal Receptacle of Wasp, 674
- Marchand, F., *Trichomonas* in Urine of Men, 697
- Marek, J., Hints in Bacteriological Technique, 265
- Marenzeller, E. v., Deep-sea Echinoderms of Eastern Mediterranean, 348
- Deep-sea Polychæta of Eastern Mediterranean, 342
- Marenzeller, E. v., Holothurians of N. Atlantic, 207
- Marginulina sequivoca*, 162
- *aspera*, 162
- *debilis*, 161
- *Folkstoniensis*, 161
- *glabra*, 160
- *hamulus*, 161
- *inæqualis*, 160
- *Jonesi*, 163
- *linearis*, 161
- *Munieri*, 163
- *robusta*, 163
- *striatocostata*, 163
- *tenuissima*, 162
- Marktanner, G., On Instantaneous Photomicrography, 110
- Marine Animals, Preservation in Formaldehyde, 532
- Marot, F., *Streptococcus* cultivated on Potato, 102
- Marpmann, —, Examining Street Dust for Tubercle Bacilli, 134
- Marshall, A. M., the late, 118
- Martin, J., Relations of Friedländer's *Pneumobacillus* and of Lactic Ferment with *B. lactis aerogenes* and *B. typhosus*, 245
- Massari, G., Supposed Cancer Parasites, 213
- Massart, J., Irritability of *Noctiluca*, 354
- Massee, G., *Trichosphæria Sacchari*, 380
- Masterman, A. T., Food of *Sagitta*, 456
- Matouschek, F., Bulbs of *Cystopteris bulbifera*, 595
- Matruchot, L., Fixity of Race in Mushroom, 723
- Parasites of Mushroom, 723
- Matsuda, S., Anatomy of Magnoliaceæ, 78
- Matthews, A. P., Wurtz's Method for Differentiating *B. typhi abdominalis* from *B. coli communis* — its Application to Examination of Contaminated Drinking Water, 614
- Mattiolo, O., Cuticle of Seeds of Papilionaceæ, 81
- Maturation of Egg of *Azotol*, 38
- of Ovum of Lamprey, 43
- — in Mammals, 541
- Maul, R., Sclerote in Alder-fruit, 720
- Maumus, —, Conversion of Starch into Sugar by *Bacillus anthracis*, 384
- Maurea, —, Differences between *B. typhosus* and "Typhoid" Bacilli, 388
- Mauritius, Ophiuroids, 349
- Mayer, A. G., Radiation and Absorption of Heat by Leaves, 373
- —, Respiration of Plants in Shade, 713
- Mayoux, —, Staminal Appendages of *Aristolochia*, 80
- "May-water," 418
- Measurement of Light and Colour Sensations, 119
- Measures, —, 768
- Mechanomorphosis, 591
- Media containing Alkali Albuminates, Nutrient, 750
- Measuring Refractive Indices of, 655, 764
- Setting Cultivations on Solid, 748
- Mediterranean, Echinoderms of Eastern, 348
- Polychæta of Eastern, 342
- Medium, Nutrient, for Bacteria, Preparation from Eggs, 399
- Medullary Folds, Segmentation in, 542
- Rays of Dicotyledonous Herbs and Shrubs, 470

- Medusa, Freshwater, from Niger, 351  
 Medusa, Craspedote, of Plankton, 575  
 Mehan, T., Compass Plants, 712  
 — T., Cross-pollination and Self-pollination, 226, 710  
 — Female Catkins in *Populus*, 222  
 — Rhythmic Growth, 228  
 Megaspore and Female Prothallium of *Selaginella*, Preparing, 632  
 — of *Selaginella*, 594  
 Meinecke, E. P., Aerial Roots of Orchideæ, 473  
 Meissner, R., Size of Leaves of Conifers, 472  
 — Transpiration and Assimilation, 711  
*Melolontha*, Stigmata of Larva, 54  
 Men, *Trichomonas* in Urine, 697  
*Mendoncia*, Anatomy of, 221  
 Mer, E., Parasitic Fungi, 234  
 — Witch-broom of Fir, 470  
 Mercaptan, Formation by Aerobic Bacteria, 607  
 Meristems, Two new Staining-reagents for, 533  
 Meroblastic Ova, Yolk-nuclei, 435  
 Merrifield, F., Temperance Experiments on Lepidoptera, 673  
 Merrill, H. B., Eye of Leech, 683  
 Mesnard, E., Formation and Localization of Fatty and Essential Oils, 702  
 — Localization of Fatty Oils in Formation of Seeds and Fruits, 468  
 — Transformation of Reserve-substances during Germination, 230  
 Mesnil, F., *Polydora*, 62  
 Mesomycetes, Brefeld's, 719  
 Mesozoic Echinoderma of United States, 689  
 Metabolic Products of *B. hydrophilus fuscus*, Physiological Effect, 495  
 Metamorphoses of Insects, 558  
 — Freshwater Ostracoda, 681  
 Metanema, 481  
 Metastasis in Germinating Tubers and Seeds, 370  
 — Marine Algæ, 483  
 Metazoa, Genetic Relations, 327  
 Metcalf, M. M., Embryology of *Chiton*, 49, 129  
 — Eyes and Subneural Gland of *Salpa*, 183  
 Meteoric Paper, 89  
 Methylene-blue, Staining Nervous Tissue, 274  
 Metschnikoff, E., Alexocytes, 243  
 — Artificial Variation of Cholera Vibrio, 499  
 — Cholera and Vibrios, 730  
 — Phagocytosis, 385  
 Mice, Caucasian Field, and *B. typhi murium*, 613  
 — Field, Destruction by Means of Pathogenic Microbes, 247  
 Mice, Inoculation Apparatus for, 125  
 Michael, A. D. (President), 146, 283, 284, 414, 416, 417, 419  
 — Notes on Uropodinae, 289  
 — Progress and Present State of Knowledge of Acari, 18  
 Micheels, H., Fruit-bearing Axis of Palms, 705  
 Michels, J., New 1/5 Objective, 737  
 Michigan, Rotatoria, 574  
 Microbe of Ozæna, 501  
 — Peripneumonia bovina, Diagnostic Value of its Soluble Products, 248  
 Microbes, Action of Sea-water on, 727  
 — and Fatty Matter, 244  
 — Assimilation of Atmospheric Nitrogen by, 97  
 — in Chronic Rheumatism, 243  
 — in Normal Urethra of Women, 613  
 — Pathogenic, Destruction of Field Mice by, 247  
 — Pyogenic, Influence of Light on, 492  
 — Water, Pathogenic Properties of, 385  
 — which evolve Hydrogen Sulphide, 492  
 Microbic Origin of Purulent Surgical Infection, 249  
 Microbicidal Action of Gallanol, 527  
 Microbiology and Manufacture of Arrack, 602  
 Microchemical Reaction of Vegetable Albumen, 644  
 — Staining Reactions of Mucin, 407  
 Micro-chemistry, 522  
 — Lepidoptera, Notes on, 443  
 Micrometer Screw Adjustment, Leitz's, 109  
 — Screws, Production of Exact, 252  
*Micronereis variegata*, Amœbocytes and Oogenesis in, 199  
 Micro-organisms, Action of Ozone on, 383  
 — — — Anaerobic, 493  
 — — — Duration of Incubation of Air and Water, on Gelatin, 494  
 — — — Effect of Sunlight on, 607  
 — — — Egg-albumen Cultivation Medium for, 268  
 — — — Is there a Cell-life without, 551  
 — — — of Rancid Butter, 496  
 — — — Staining in Blood, 757  
 Microscope, Baker's Photographic, 517  
 — Beck's "Continental," 616  
 — Diagnosis of Cholera by, 535  
 — Farmer's, 106  
 — for Measurement of Growth of Plants, 103  
 — Heating Arrangement for Bacteriological purposes, 630  
 — Home-made, 414  
 — Lamp, Chimney for, 108  
 — Lamps, Clay Wick for, 738  
 — Leitz's, 103  
 — Lemardeley's Photographic, 518  
 — Practical Instructions for Making, 620



- Microscope Staud, Improvements and Additions, 392  
 — Support, 736  
 — Swift's Four-legged, 285, 506  
 — — New 'Histological,' 251  
 — Technique, Plea for Systematic Instruction at the University, 627  
 — Theoretical Limit, 263  
 — Watson's Van Heurek, 761  
 — Zentmayer's Portable, 771  
 Microscopes, Koristka's, 616  
 — Ross "Eclipse," 507, 734, 762  
 Microscopic Foam and Protoplasm, 437  
 — Objects, Kuster's Hollow Spheres for, 135  
 — Preparations, Collection, 760  
 — Vivisection, 210  
 Microscopical Optics. See CONTENTS, xxxi  
 — Society, Liverpool, 264  
 — — of Calcutta, 264  
 — Technique, Bachmann's, 266  
 — — Friedländer's, 137  
 — — Von Kahlde's, 137  
 Microscopy, Giltay's Introduction to Study of, 522  
 — Kitt's Pathological, 137  
 — of Blood, Atlas of Clinical, 136  
 Microsporidia, Spores, 465  
 Microtechnique, Botanical, 523, 632  
 Microtomes. See CONTENTS, xxxiv  
 Microtometist's Vade Mecum, Lee's, 120  
 Middlemass, —, Method of Preparing Fresh Sections of Brain, 271  
 Mid-gut Gland, Histology, 440  
 Mie, G., Modification of Wolffhügel's Colony Counter, 529  
 Mielke, G., Formation and Function of Tannins, 703  
 Miller, C. O., Aseptic Protozoa Cultures, 744  
 — Bacteriology of Teeth-pulp, 727  
 — Short Notes on Bacteriological Technique, 524  
 Milne-Edwards, A., Galatheidæ, 565  
 Mimicry, 52  
 — False, 552  
 Minchin, E. A., Embryology of Porifera, 460  
 — Microscopic Foam and Protoplasm, 437  
 Mineralogical Microscope, Koristka, 616  
 Minerals, New Machine for Cutting Thin Sections of, 533  
 Mingazzini, P., Classification of Sporozoa, 71  
 — Degeneration of Frog Ova, 545  
 Minorca, Ascidians, 51  
 Minot, C. S., Bibliography of Vertebrate Embryology, 325  
 — Concerning the Gonotome, 176  
 Minyadæ, 350  
 Miquel, P., Cleaning Diatoms, 278  
 — Duration of Incubation of Air and Water Micro-organisms on Gelatin, 494  
 Miquel, P., Nucleus of Diatoms, 240  
 — Re-establishment of Size of Diatoms, 606  
 — Setting Cultivations on Solid Media, 748  
 — Spores of Diatoms, 240  
 Mirrors, Construction of Silvered Lens, 254  
 Mistletoe, Life-history, 478  
 Mitford, C. B., Flight of Locusts, 445  
 Mitoses, Generative and Embryonic, 550  
 — Study, 751  
 Mitrophanow, P., Embryogeny of Selachii, 175  
 Mitsukuri, K., Gastrulation in Chelonia, 664  
 — Preparation and Preservation of Embryos of Chelonia, 750  
 Miura, K., *Trichomonas* in Urine of Men, 697  
 Miyoshi, M., Chemotropic Movements, 479  
 Möller, A., Fungus which forms several Different Lichens, 237  
 Moeller, H., Fixing and Staining the Nuclei and Spores of Yeast, 276  
 — M., Spores of Yeast, 235  
 Molisch, H., Indican, 469  
 — Physiology of Pollen, 474  
 Mollusca. See CONTENTS, x  
 Molluscan Ova, Preparation, 272  
 Molluscoida. See CONTENTS, xi  
*Monarda*, Fertilization, 84  
 Moniez, M. R., *Selenosporium aquæductum* (Musk-fungus), 724  
*Moniligaster*, 569  
*Monocercomonas Hominis*, 212  
 Monochromatic Light Screen, New, 141, 164  
 — — of any desired Wave-length, Instrument for producing, 394  
 Monocotyledons, Increase in Thickness of Stem, 469  
 Monpillard, —, Oriochromatism applied to Photomicrography, 113  
 Monteverde, N., Absorption-spectrum of Chlorophyll, 701  
 Monticelli, F. S., *Ligula* as Food in Italy, 573  
 — Parasites of Holothurians of Naples, 45  
 Moore, J. E. S., Archoplasm and Attraction-sphere, 666  
 — J. P., Leech-like Parasites of American Crayfishes, 343  
 Moraceæ, Influence, 472  
 Morax, V., Staining Flagella, 406  
 Mordant, Flagella-staining without, 756  
 More, jun., J., 538  
 Morgau, T. H., Development of *Balanoglossus*, 573  
 — Experimental Embryology illustrated by Echinoderms, 348  
 — Experimental Studies on Eggs of Teleosteans, 40



- Morgan, T. H., Preserving Larvæ of *Balanoglossus*, 631
- Morin, F., Venation of Muscineæ, 596
- Mortensen, T., Anatomy and Development of *Cucumaria glacialis*, 456  
— *Ophiopus arcticus*, 67
- Moths, Indian, 189  
— Life-history of Bombycine, 187
- Mottier, D. M., Embryo-sac of *Acer rubrum*, 367  
— *Pleodorina*, a new Genus of Volvocineæ, 718
- Mounting Objects. See CONTENTS, XXXV
- Mouse, Fertilization, 174  
— -disease, Bacillus of, 390
- Mouth-parts of Trichoptera, 54  
— Streptococci in Healthy and Unhealthy, 498
- Movements of Diatoms, 606  
— Flowers and Leaves, 229  
— Flower-stalk of *Cobæa*, 229  
— Flowers of *Veronica*, 229
- Mrázek, A., Antennæ of Cyclopidæ, 58
- Muciferous Cells in Yew, 586
- Mucilage, Formation by Aquatic Plants, 585  
— Layer in Flax-seeds, 78
- Mucin, Microchemical Staining Reactions, 407
- Mucorini, Nuclei, 486  
— Structure of Nucleus, 701
- Mucus, Germicidal Properties of Human, 268
- Mühsam, R., Pigment-production of *Bacillus pyocyaneus* in Symbiosis with other Organisms, 495
- Mueller, A., Helminthological Notes, 685  
— G. W., Ostracoda of Naples, 680  
— Preserving Ostracoda, 751  
— J., Succulent Compositæ, 365  
— Wrinkle-scurf, 380  
— K., Anthrax in Rats, 246  
— Inoculation Apparatus for Rats and Mice, 125  
— New Genera of Musci, 232  
— L., Anatomy of Petals, 587  
— O., Movements of Diatoms, 382, 607
- Müllerian Duct, Development in Mammals, 322
- Müntz, A., Ammoniacal Fermentation of Earth, 244
- Murray, G., Parasites on Algæ, 87
- Muscineæ. See CONTENTS, xxv
- Muscle Degeneration in Barbel from presence of Myxosporidia, 72  
— Fibres of *Ascaris*, Conducting Element in the, 570  
— — of Mollusca, 49  
— Striped, Histology and Histogenesis, 550
- Muscles, Absolute Force of, 673  
— Striped, Relations of Isotropic to Anisotropic Layers in, 437
- Muscular Action in *Bombyx*, 52
- Muscular Cells of *Ascaris*, 685  
— Fibres in a Trematode, Striated, 571
- Museum, Berlin, Salpæ of, 183  
— Making and Preserving Specimens of Bacteria for, 531
- Mushroom, Parasites, 723
- Mushrooms, Fixity of Race, 723
- Musk Fungus, 724
- Must, Inspissated, and Cultivation of Fungi, 270
- Mycetozoa. See CONTENTS, xxvii
- Mycoderma*, New Form of Propagation in, 236
- Myology of *Palinurus Edwardsi*, 57
- Myriophyllum*, Contents of Trichomes, 76
- Myriopoda. See CONTENTS, xiii
- Myrosin in Plants, 76
- Mysis*, Germinal Area, 57
- Myxine glutinosa*, Examination of Nervous System, 631
- Myxomycete in *Succammina*, 696
- Myxomycetes, New, 490
- Myxosporidia, Classification, 465  
— Interrelations, 355  
— Muscle Degeneration in Barbel from, 72
- Myxotheca*, Investigation, 273  
— *arenilega*, 212
- Myzostoma*, Protandric Hermaphroditism in, 456

## N.

- Nabias, B. de, Remarks on Histological and Bacteriological Technique, 121
- Nacht Camera Lucida, 623
- Naegelia*, 486
- Nagel, W. A., Sense of Light in Eyeless Bivalves, 441
- Nanism, Experimental, 670
- Naples, Ostracoda, 680  
— Parasites of Holothurians, 45  
— Tetractinellidæ, 691
- Nastiukow, M., Egg-yolk Medium for Cultivating Influenza Bacillus, 269, 271  
— Staining Tubercle Bacilli in Sublimate Solutions of Anilin Dyes, 276
- Nasutus of *Eutermes*, Origin, 560
- Natal Diatoms, 765
- Nautilus*, Shells, 553
- Navel of Apophyse of Fruit-scales of *Pinus*, 364
- Navicella*, Nervous System, 181
- Naviculoid Diatoms, 765
- Nawaschin, S., Embryology of Amentiferæ, 708  
— Fungus-parasite of *Sphagnum*, 235
- Nectaries of *Aleurites*, Extra-floral, 705
- Necturus*, Ectodermic Differentiation, 544  
— Investigation of Blood, 402  
— Ontogenetic Differentiations of Ectoderm in, 39
- Needle, Infection-, 748

- Nelson, E. M., 141, 146, 283  
 — Chimney for Microscope Lamp, 108  
 — Construction of Silvered Lens Mirrors, 254  
 — Farmer's Microscope, 106, 138  
 — Hints on Photomicrography, 394  
 — Leitz's New Microscope, 103  
 — Lovibond's Screens, 138  
 — Measurement of Light and Colour Sensations, 119  
 — Nias on the Continental Microscope, 139  
 — Reflecting Camera Lucida, 771  
 — Simple Method of Measuring Refractive Indices of Mounting and Immersion Media, 655, 764, 771  
 — Zentmayer's Portable Microscope, 771  
 Nematelminthes. *See* CONTENTS, xv  
 Nemertinea, French, 571  
 Nemertines, Developmental History of, 344  
 Nematode of Coffee-disease, 452  
 Nematodes, Anatomy, 202  
 — and Sugar Cane, 570  
 — Australian and Fijian, 202  
 — New Genera, 451  
 — of Pharyngeal Glands of Ants, 64  
 — Schneider's Pore and Oesophageal Glands in, 63  
 — Structure, 452  
 Neotænioglossæ, 46  
 Nephelis, Excretory System, 343  
 Nephridia of *Lymanæus*, Primitive, 556  
*Nephrocytium lunatum*, 13  
 — *obesum*, 13  
*Nerita*, Nervous System, 181  
 Nerve-centres, Minute Structure, 325  
 — -cord of Rays, 326  
 — -endings, Free, in Epithelium of Earth-worms, 568  
 — -fibres, Demonstrating Intercalary Rings of, 133  
 — - - of Central-Nervous System, Cox's Method for Demonstrating, 134  
 — Supply of Cardiac Ventricles, 755  
 — of Mammalia, Staining Intrinsic Pulmonary, 755  
 Nerves of Oculiferous Tentacle of *Helix pomatia*, 440  
 Nervous System of Chætopoda, Supporting Tissues of, 198  
 — — of *Dreissensia polymorpha*, 328  
 — — of Embryonic Lobster, Histology, 563  
 — — of *Myxine glutinosa*, Examination, 631  
 — — of *Nerita* and *Navicella*, 181  
 — — Recent Methods of Staining Central, 768  
 — Tissue, Changes caused by Hardening Reagents, 642  
 — — Staining with Methylene-blue, 274  
 Nesgenyi, C., Germination of Seeds, 477  
 Nestler, A., Pearl-glands, 367  
 Neubner, E., Calycieæ, 94  
 Neuhaus, R., Comparison between Petroleum, Gas, and the Auer Light with Respect to Photomicrographic Work, 627  
 — Photomicrograms of Ice and Snow Crystals, 741  
 — Photomicrography and Projection, 393  
 Neumann, A., Disruption Products of Nuclein Acid, 552  
 — G., Parasitic Fungi, 489  
 Neumeister, R., Proteolytic Ferments in Seedlings, 704  
 New South Wales *Balanoglossus*, 454  
 — Zealand, Subterranean Crustacea, 678  
 Newcomb, C. F., Crustacea and Marine Shells of British Columbia, 328  
 Newcombe, F. C., Influence of Mechanical Resistance on Development of Cells, 711  
 Newt Ova, 631  
 Newton's Triple Rotating Electric Lantern, 410  
 Nias, J. B., 139  
 Nichols, M. A., Achenial Hairs of Compositæ, 367  
 Nicolle, M., Staining Flagella, 406  
 Nicotine, Localization in Tobacco-plant, 361  
 Nietsch, V., Tracheal System of *Locusta*, 446  
 Niger, Freshwater Medusa, 351  
 Nilsson, A., Parasitic Fungi, 234  
 Nitrates in Living Plants, 469  
 Nitrication, *Bacillus mycoides* and, 98  
 Nitrogen, Assimilation by Plants, 478  
 — Atmospheric, Assimilation by Microbes, 97  
 — Free, Assimilation by Plants, 86  
 — — Fixation by Algeæ, 592  
 — — by Leguminosæ, 479  
 Nitsche, P., *Tetramitus Nitschei*, a Parasite of Goldfish, 699  
 Noack, E. J., *Distomum clavigerum*, 65  
 — F., Cancer of Ash produced by Bacteria, 243  
 Nobbe, F., Fixation of Free Nitrogen by Leguminosæ, 479  
*Noctiluca*, Irritability, 354  
 — *miliaris*, Reproduction, 693  
 — Nuclear Division, 464  
*Noctua pronuba*, Reproductive Organs, 188  
 Nogakushi, K. T., Spermatogenesis of *Bombyx Mori*, 187  
 Noll, F., Geotropism and Epinasty, 370  
 — Influence of Phosphorus on Growth of Plants, 476  
 — Transpiration of Succulent Plants, 370  
 North Sea, Cephalopoda, 45  
 — — Ophiuroids, 67  
 Notochord and Hypophysis, Relations in Birds, 544  
 Novy, F. G., Apparatus for Cultivating Anaerobic Bacteria, 397  
 — Cultivating Media for Anaerobic Bacteria, 127

Nucellus of Ovule of *Croton*, 368  
 Nuclear Division in *Euglena*, 577  
 — — in Hymenomyces, 380  
 — — in *Noctiluca*, 464  
 — — in Pollen-mother-cells of *Lilium Martagon*, 74  
 Nucleated Red Corpuscles, Demonstrating, 639  
 Nuclei, Degeneration, 326  
 — of Anthrax Spores, 385  
 — — — Staining, 406  
 — of Embryo-sac, Chromatophily of, 473  
 — of Mucorini, 486  
 — of Yeast, Fixing and Staining, 276  
 Nuclein Acid, Action on Bacteria, 607  
 — — Disruption Products, 552  
 Nucleoles and Centrosomes, 583  
 — Behaviour during Karyokinesis, 583  
 Nucleolus in *Psilotum*, 360  
 Nucleus and Cytoplasm, Independence, 467  
 — and Protoplasm, 44  
 — Centrospheres, 581  
 — Function, 582  
 — in Mucorini, Structure, 701  
 — Interactions between, 43  
 — Nature, 582  
 — of Crescentiform Bodies of Malaria, Structure, 466  
 — of Diatoms, 240  
 — of Germinating Seeds, 74  
 — Relations to Spore-formation in Liverworts, 232  
 — Structure, in Ovarian Ovum of *Triton*, 545  
 Nusbaum, J., Behaviour of Pigment Granules during Karyokinesis, 44  
 Nutrition of Phanerogams. *See* CONTENTS, xxii  
 Nutritive Processes in Porifera, 461  
 Nymphaeaceæ, Leaves, 366  
 — Morphology, 588  
 Nypels, —, Tubers of *Apios tuberosa* and *Helianthus tuberosus*, 83

O.

*Obelia*, Regeneration, 459  
 Object-glasses, Method for Increasing the N.A. of Old Achromatic, 286, 413, 518  
 Objectives. *See* CONTENTS, xxxi  
*Ocineon Lindahli*, 208  
*Octopus Diqueti*, Breeding Habits, 328  
 — *vulgaris*, Fecundation, 554  
 Oculiferous Tentacle of *Helix pomatia*, Nerves, 440  
 Œsophageal Glands in Nematodes, 63  
 Ogata, M., Cultivating Protozoa, 123  
 Ohlmacher, A. P., Production of Artefacts by certain Fixatives, 757  
 Oils, Formation and Localization of Fatty and Essential, 372, 703

Olfactory Organ, Development in Teleostei, 665  
 Oligochaeta, New or Little-known, 683  
 — of E. Tropical Africa, 568  
 — Septal Glands, 682  
 Olive, E. W., Histology of *Pontederia*, 586  
 Olive Oil, Influence on Disinfectants, 608  
 Oliver, F. W., Effects of Fog on Plants, 231  
*Oncidiella coquimbensis*, 556  
 Oncidiidæ, 47  
*Oncodes*, Larva, 675  
 Ontogenetic Differentiations of Ectoderm in *Necturus*, 39  
*Oocystis asymmetrica*, 14  
 — *crassa*, 15  
 — *elliptica*, 14  
 — *gigas*, 14  
 — — var. *incrassata*, 14  
 — *nodulosa*, 15  
 — *Novæ Semliæ*, 13  
 — — — var. *maxima*, 13  
 — *panduriformis*, 15  
 — — var. *pachyderma*, 16  
 — *solitaria*, 15  
 — — var. *notabile*, 15  
 Oogenesis in *Cyclops*, 330  
 — in *Micronereis variegata*, 199  
 Oolitic Sand from Great Salt Lake, 536  
*Ophelia radiata*, Chlorogogen, 341  
 Ophioglossaceæ, Symbiotic Fungus, 94  
*Ophiopus arcticus*, 67  
 Ophiuroids of Mauritius, 349  
 — of North Sea, 67  
*Ophryotrocha*, Development, 340  
 Optical Properties of Wood, 519  
 Optics, Microscopical. *See* CONTENTS, xxxi  
 — of Photography, 741  
*Orbulina*, Enclosure of *Globigerina* by, 464  
 Orchideæ, Aerial Roots, 473  
 Organogeny of *Asterina gibbosa*, 206  
 Orienting Small Objects for Sectioning, 532  
 Origin of Blood, 175  
 — of Mammals, 172  
 Orłowski, —, Demonstrating Sulphuretted Hydrogen generated by Bacteria, 530  
 Orthoptera, Alimentary Canal, 445, 560  
 — Anatomy and Development of Female Genital Armature, 191  
 — Heart, 675  
 — of Galapagos, 55  
 Orthochromatism applied to Photomicrography, 113  
 Ortmann, A., Pelagic Schizopoda, 679  
 Osborn, H. L., *Perigonimus*, 351  
 Oscillatoriaceæ, 241  
 Osenbrug, —, Rumination of Seeds of *Areca catechu*, 706  
 Osmic Mixtures, Bleaching Animals and Sections fixed with, 534  
 Osseous Tissue, Method for Histological Examination, 130



- Osteomyelitis, Presence of *Diplococcus pneumoniae* and *Streptococcus pyogenes* in, 245
- Ostracoda of Naples, 680
- Preserving, 751
- Oswald, A., Proboscis of Prosobranchs, 328
- Ova of *Ascaris*, Experiments with, 201
- British Fishes, 665
- Frog, Degeneration, 545
- Meroblastic, Yolk-nuclei in, 435
- Molluscan, Preparing, 272
- Newt, 631
- Ovens, Apparatus for Regulating Temperature, 122
- Oviposition in Acrididae, 560
- Ovule of *Croton*, Nucellus, 368
- Ovum in Mammals, Maturation, 541
- of *Branchipus*, 59
- Lamprey, Maturation, 43
- *Triton*, Structure of Nucleus in Ovarian, 545
- Trout's, Fertilization, 435
- Oxalic Acid, Distribution in Plants, 217
- Oxychinaseptol, Antibacterial Action, 268
- Oxygen, Exchange of Carbon Dioxide and, 711
- Influence on Alcoholic Fermentation, 594
- Production, 592
- Ozæna, Capsule Bacillus, 100
- Microbe, 501
- Ozone, Action on Micro-organisms, 383
- P.
- Pacini's Preserving Fluid, 758
- Packard, A. S., Life-history of Bombycine Moths, 187
- Transformations of Saturniidae, 559
- Pagurinae, Conversion into Lithodinae, 678
- Pal, J., Microtome for Brain-sections, 636
- Palæmon serratus*, Correlation of Certain External Parts of, 449
- Palinurus Edwardsi*, Myology, 57
- Palisade-cells and Transpiration, 470
- Palla, E., Karyoid, a new Organ of Conjugatae, 717
- Protoplasts of Cyanophyceae, 383
- Palladine, W., Intramolecular Respiration dependent upon Carbohydrates, 594
- Respiration of Green and Etiolated Leaves, 371
- Pallavicinia decipiens*, 483
- Pallial Organs of Tectibranchiata, 669
- Palms, Fruit-bearing Axis, 705
- Pammel, L. H., Aromatic Bacillus of Cheese, 391
- Hybridism in Cucurbitaceae, 475
- Parasitic Fungi, 93, 489
- Pane, N., Liquefaction of Gelatin by *Streptococcus pyogenes*, 727
- Pantel, J., Muscular Cells of *Ascaris*, 685
- Pantopoda of Albatross Expedition, 193
- Papayaceae, Active Principles of, 468
- Papilionaceae, Cuticle of Seeds of, 81
- Filaments of Tubercles, 609
- Parascandole, C., Egg-Albumen as Cultivation Medium for Micro-organisms, 268
- Parasite, Cancer, 356, 698
- Cancer, Demonstrating, 273
- Fungus-, of *Sphagnum*, 235
- Goldfish, 699
- *Gunnera*, 725
- Madura Foot, 390
- Penguin, 762
- *Perophora unnectens*, 692
- Skin Cancer, 355
- Vaccinia and Variola, 697
- Parasites, Catalogue of, 667
- Dipterous, of Locusts, 446
- Endoglobular, of Blood of Vertebrates, 578
- Haustoria of Phanerogamia, 82
- Leech-like, of American Crayfishes, 343
- Living, in Blood of Cancerous Persons, 580
- Malaria, Influence of Cold on Vitality of, 357
- of Summer and Autumn Fevers, Structure, 700
- Nutrition of Green, 711
- of Cyclopidæ, 71
- of Holothurians of Naples, 45
- of Mushroom, 723
- in Sarcoma, 698
- on Algae, 87
- Study of Endoglobular, 632
- Supposed Cancer, 213
- Parasitic Alga, New, 717
- Cell-inclusions, their Cultivation, 748
- — — in Sarcomatous Tissue, 213
- Diptera, on Acrididae, 560
- Fungi, 93, 234, 378, 488, 601, 722
- Growths on Root-hairs, 763
- *Hymenogaster*, 724
- Loranthaceae, Root, 473
- Puccinias, on Compositae, 238
- Saprophytic Fungus becoming, 92
- Vorticellæ, 211
- Parasitism, Dimorphism due to, 439
- of *Epiphegus*, 586
- Paris, Mollusca of Water Mains, 182
- Parker, G. H., Staining Nervous Tissue with Methylen-blue, 274
- T. J., Myology of *Palinurus Edwardsi*, 57
- Paroni, E., Parasitic Fungi, 723
- Parthenogenesis in Plumicolous Sarcopitidæ, 448, 677
- of *Artemia*, 339
- Pasquale, A., Streptococci, 497
- F., Cross-pollination and Self-pollination, 589



- Patents for Inventions, 120  
 Paternò, E., New Substance extracted from Lichens, 488  
 Pathogenic Action of *B. pyocyaneus* on Human Beings, 613  
 — Anaerobes of Soil, Influence of Physico-Chemical Agents on, 387  
 — Bacillus of Frogs, 730  
 — Infusorian, to Pigeons, 211  
 — Microbes, Destruction of Field Mice by, 247  
 — Properties of Water Microbes, 385  
 Pathological Microscopy, Kitt's, 137  
 Patrizi, M. L., Muscular Action in *Bombix*, 52  
 Patten, W., Artificial Segmentation of *Limulus*, 336  
 — Mounting Small Objects in Cells, 534  
 — Orienting Small Objects for Sectioning, 532  
 — Structures resembling Dermal Bones in *Limulus*, 448  
*Pauropus*, Structure, 447  
 Pawlowsky, A. D., Parasitic Cell-Inclusions in Sarcomatous Tissue, 213  
 — Phagocytosis and Actinomycosis, 611  
 Pear, Pollination, 710  
 Pearl-glands, 367  
 Pectic Substances in Tissues, 75  
*Pedalion*, 574  
*Pediastrum*, Development, 599  
 Pedicel of Teleutospores of Pucciniæ, 722  
 Peglion, V., Malformations produced by *Cystopus candidus* and *Ræstelia cancellata*, 234  
 — Parasitic Fungi, 722  
 Peirce, G. J., Biology of *Cuscuta*, 480  
 — Haustoria of Phanerogamic Parasites, 82  
*Pelagia*, Development, 69  
 Pelagic Schizopoda, 679  
*Pelargonium*, Spurs, 363  
 — zonate, Formation of Starch in, 372  
*Pellia*, Centrospheres in Spores of, 581  
 Pellicle of Algæ, 89  
*Pelomyxa palustris*, Minute Structure, 463  
 Pelsener, P., Branchiate Pulmonates, 670  
 — Shell Cavity of Philinidæ, 182  
 — Excretory and Reproductive Apparatus of *Elysia*, 180  
*Peltella*, 556  
 Peneceæ, Structure, 362  
 Penguin Parasites, 762  
*Penicillium*, Sclerote-forming Species, 720  
 — *Duclauxi*, Physiology, 94  
 — *luteum*, Development, 379  
*Penium Clevei* var. *crassum*, 4  
 — *cucurbitinum*, 4  
 — *inconspicuum*, 4  
 Penzig, O., Pearl-glands, 367  
 Perfume of Violet, 231  
 Perianth, Red Colour, 226  
 Peribranchial Cavity, Origin in Ascidian Embryos, 50  
 Pericycle, Internal, 219  
*Peridinium acuminatum*, Polymorphism, 71  
 — Chain-forming, 580  
*Perigonimus*, 351  
 Perimedullary Zone, 361  
 Periostitis, Presence of *Diplococcus pneumoniae* and *Streptococcus pyogenes*, 245  
*Peripatus*, 561  
 — Egg, Hatching, 191  
 Peripneumonia bovina, Microbe of, Diagnostic Value of its Soluble Products, 248  
 — Bovine, Experimental Production, 610  
 Pernossi, L., Enzymes, 360  
*Perophora annectens*, 672  
 — — Parasite of, 692  
 Perrey, A., Wine-Yeasts, 720  
 Perrier, E., Arthropoda, 51  
 — Asteroidea of 'Travailleur' and 'Talisman' Expeditions, 205  
 — Brooding Habits of *Octopus Digueti*, 328  
 Perroncito, E., Growth of *Tænia mediocanellata*, 688  
 Petals, Anatomy, 587  
 Peter, A., Germination of Dormant Seeds, 368  
 Petermann, A., Assimilation of Free Nitrogen by Plants, 86  
 Petersen, O. G., Increase in Thickness of Stem of Monocotyledons, 469  
 — W., Psorosperms of Darier's Disease, 73  
 Petri, R. J., Formation of Sulphuretted Hydrogen and Mercaptan by Aerobic Bacteria, 607  
 Petri's Capsules, Counting Apparatus specially adapted for, 393  
 Petroff, —, Parasites of Sarcoma, 698  
 Petroleum, Gas, and Auer Light, Comparison between, with respect to Photomicrographic Work, 627  
 — Lamp, Incubator working with a, 513  
 Petrological Microscope "Eclipse," 736  
 Pewsner, —, Staining Tubercle Bacilli in Sublimite Solutions of Anilin Dyes, 276  
 Peytoureau, A., Female Genital Armature of Lepidoptera, 332  
 — — — Orthoptera, 191  
 — Male Genital Armature of Lepidoptera, 332  
 Pfeffer, W., Causes of Disappearance of Reserve Food-materials from Seeds, 371  
 — Irritability, 370  
 — Work and Pressure in Growing Plants, 590  
 Pfeiffer, R., Influenza Bacillus, 100  
 — Studies on Ætiology of Cholera, 614  
 Pfuhl, —, Presence of *Vibrio Metschnikovi* in an Open Watercourse, 733  
*Phacelia*, Fertilization, 84  
 Phagocytosis, 385  
 — and Actinomycosis, 611

- Phalangiidae, Eye, 562  
 Phalloidæ, 381  
 Phanerogamia *See* CONTENTS, xix  
 Pharyngeal Glands of Ants, Nematodes of, 64  
 Philinidae, Shell Cavity of, 182  
 Philippi, R. A., *Callirhabdos*, 691  
 — European and Chilian Crustacea, 677  
 Phisalix, C., Inhibition in Cephalopoda, 45  
 — Red Pigment of *Pyrrhocoris apterus*, 559  
*Phormidium*, 241  
 Phosphorescence, Absence in Cholera Cultures, 399  
 Phosphorus, Influence on the Growth of Plants, 476  
 Photographic Camera, Edinger's, 285  
 Photography, Optics, 741  
 Photometry, New, 739  
 Photomicrography. *See* CONTENTS, xxxi  
 — Stereoscopic, 413  
 Photomicrographs forming the Society's Exhibits at the Chicago Exhibition, 420  
*Phreoryctes endeka*, 342  
 Phthitiscal Cavities, Fungus found in, 97  
 — Sputum, New Method for Detecting Tubercle Bacilli in, 402  
 Phycochronaceæ, Structure of Cells of, 240  
*Phyllophora*, 484  
 Phyllotaxis, Mechanical Theory of, 706  
 Phylogeny of Chordata, 438  
 — of Pierinæ, 443  
 Phylloxeridæ, Anatomy, 675  
*Physcomitrium*, 596  
 Physiological Effect of Soluble Products of Pyogenic Staphylococci, 610  
 Physiology of Phanerogams. *See* CONTENTS, xxii  
*Physotium*, Stem and Leaves, 375  
 Physodes, 359  
*Phytelephas*, Endosperm of, 588  
 Pianese, G., Formic Acid Hæmatoxylin, 405  
 Pictet, R., Germination of Seeds, 476  
 — Influence at Low Temperature, 178  
 Pierce, N. B., Parasitic Fungi, 601  
 Pierinæ, Phylogeny of, 443  
 Piersol's Histology, 266  
 Piffard, H. G., Method of Increasing the N.A. of old Achromatic Object-glasses, 286, 413, 518  
 Pig, Coarse and Fine Spirilla in Gut, 731  
 Pigeons, Infusorian Pathogenic to, 211  
 Pigment-granules during Karyokinesis, Behaviour, 44  
*Pilumnus hirtellus*, Habits, 567  
 Pineal Eye, Derivation, 176  
 Pinnipedia, Dentition of, 36  
 Pintner, T., Preservation of Marine Animals in Formaldehyde, 532  
*Pinus*, Fertilization, 474  
 — Navel of Apophyse of Fruit-scales, 364  
 Pirotta, R., Polymorphism of *Cladosporium herbarum*, 94  
 Pitchered Insectivorous Plants, 364  
 Placenta, Morphology, 541  
 Placentation of Shrew, 321  
 Plague, Bubo, Bacillus, 730  
*Placospongia*, Systematic Position, 210  
 Planarians, Land, from Tasmania and South Australia, 202  
 — Notes on Land, 686  
 Planchon, L., Bacteriological Study of Drinking-water of Montpellier, 391  
 — Note on Fluorescent and Liquefying Bacillus of Drinking-waters of Montpellier, 503  
 Plankton, Craspedote Medusæ of, 575  
 — Distribution of Lacustrine, 552  
 — Expedition, Bacteriology, 502  
*Planocera inquilina*, 452  
*Plantago*, Embryo-sac of, 489  
*Plasmodiophora Brassicæ*, 490  
 Plasomes, 360  
 Plastogamy of *Actinosphaerium*, 577  
 Plate Cultivations of Anaerobes, 270  
 — — Photographing, 263  
 Plate, L. H., Circulatory and Renal Organs of Chitons, 440, 556  
 — *Gadina peruviana*, 329  
 — *Oncidiella coquimbensis*, 556  
 — *Oncidiidæ*, 47  
 — *Temnocephala chilensis*, 686  
 Plateau, F., False Mimicry, 552  
 Platt, J. B., Ectodermic Differentiation in *Necturus*, 544  
 — Ontogenetic Differentiations of Ectoderm in *Necturus*, 39  
 Platyhelminthes. *See* CONTENTS, xv  
*Pleodorina*, New Genus, 717  
 Plessis, G. du, *Emea lacustris*, 202  
*Pleurococcus*, New, 382  
*Pleurosigma angulatum*, Ultimate Structure, 141  
*Pleurostichidium*, 89  
*Pleurotænium truncatum* var. *granulatum*, 3  
 Plimner, H. G., Parasite of *Vaccinia* and *Variola*, 697  
 Pliocene Foraminifera, 577  
 Plowright, C. B., *Puccinia Paridis* and *interstitialis*, 238  
 Plumicolous Sarcopitidæ, Parthenogenesis in, 448, 677  
*Pneumobacillus*, Friedlaender', Relations with *B. lactis aerogenes* and *B. typhosus*, 245  
*Pneumococcus*, Acquired Immunity to, 99  
 Pneumonia Cocci, Sputum as Cultivation Medium for, 271  
 Pocock, R. L., Instincts of Common English Spiders, 55  
 — *Peripatus*, 561  
 Podwyssoczky, W. W., Development of *Coccidium oviforme* in Bile-duct of Rabbits, 355  
 — Morphology of Cholera Vibrios, 102  
 Poirault, G., Uredinæ and their Hosts, 489

- Poirault, G., Vegetative Organs of Vascular Cryptogams, 715
- Poison-Apparatus of Hymenoptera, 445
- -Glands of Chilopoda, 676
- Pollard, H. B., Development of Head of *Gobius Capito*, 175
- Pollen-grains, Germination, 590
- Influence on Fruit and Seed, 368
- -mother-cells of *Larix*, Karyokinesis, 74
- - - - of *Lilium Martagon*, Nuclear Division in, 74
- of *Vinca major*, Germination of, 84
- Physiology, 474
- Pollination, Cross- and Self-, 225, 589, 709
- of Hop, 710
- of Pear, 710
- of *Yucca*, 226
- Polycerad, New, 182
- Polyceerus*, 455
- Polychæta, Deep-sea, of Eastern Mediterranean, 342
- of Dinard, 682
- Polyclinidæ, Genital Products in, 330
- Polydora*, 62, 199
- Polymorphism in Japanese Butterflies, Seasonal, 444
- of *Cladosporium herbarum*, 94
- of *Cladothrix*, 726
- of *Peridinium acuminatum*, 71
- of *Trentepohlia*, 233
- Polynoid with Branchiæ, 199
- Polyplacophora, Notes, 670
- Polypostia similis*, 345
- Polysaccum*, 490
- Polysporella*, 212
- Polytomeæ, 579
- Pompholyx*, Position, 381
- Pontederia*, Histology, 586
- Pontelliidæ, 58
- Populus*, Female Catkins in, 222
- Pores of Desmidiaceæ, 484
- Porifera. See CONTENTS, xvii
- Port Erin, Lucernaria, 460
- Portele, K., Fermenting Grape- and Apple-must with Pure-bred Yeasts, 235
- Potamogeton*, Propagation, 591
- Potash-Albumen, Bactericidal Properties, 493
- Potato, Growth of Cholera Bacilli on, 128
- Potonić, H., Classification of Sillaridæ, 374
- Position of Sphenophyllaceæ, 595
- Pseudo-vivipary of *Juncus bufonius*, 477
- Pouchet, G., Polymorphism of *Peridinium acuminatum*, 71
- Pouiklo, S., Easy Method for Demonstrating Cholera Vibrios in Water, 274
- Poulton, E. B., Colours of Lepidopterous Larvæ, 188
- Homologies and Origin of Mammalian Hair, 543
- Sexes of Larvæ of *Smerinthus populi*, 188
- Pound, C. J., Stock Institute in Queensland, 415
- Præoral Lobe, Evolution, 330
- Prantl, K., Classification of Ferns, 481
- Prenant, A., Development of Thymus, Thyroid, and Carotid Glands, 323
- Preparing Objects. See CONTENTS, xxxiii
- Preservative Fluids. See CONTENTS, xx xv
- President's Address, 18
- Prillieux, E., Bacillar Diseases of Plants, 492
- Parasitic Fungi, 93, 379, 489
- Print, Magnifier for Reading, 739
- 'Prinz Adalbert,' Tunicata collected by the, 183
- Prism, Experiments with Right-angled, 742
- Pair, Lummer-Brodhun, Colorimeter with, 740
- Proboscis of Prosobranchs, 328
- Projection Preparations, Cooling of, 112
- Prosobranchs, Proboscis, 328
- Proteinaceous Crystalloids, 468
- Proteolytic Ferments in Seedlings, 704
- Prothallium, Female, of *Selaginella*, 594, 632
- Protobasids, Insertion of Spores and Direction of Septa in, 486
- Protocoecus*, Filamentous Form, 725
- Protonema, 481
- Protophyta. See CONTENTS, xxvii
- Protoplasm, Chemistry, 45
- Microscopic Foam and, 437
- Nucleus and, 44
- of Plants. See CONTENTS, xix
- Protoplasts of Cyanophyceæ, 383
- Protozoa. See CONTENTS, xvii
- Cultivating, 123
- Cultures, Aseptic, 744
- Demonstrating in Drinking-water, 274
- Protracheata. See CONTENTS, xiii
- Prouho, H., Contributions to our Knowledge of Polyzoa, 183
- Prove, —, Assimilation of Free Nitrogen by Plants, 86
- Prunet, A., New Genera of Chytridiaceæ, 718
- Parasitic Fungi, 93
- Przesmycki, M., Cell-granules in Protozoa, 691
- Pseudo-cilia and Cilia, 701
- -fecundation in Uredineæ, 238
- -vivipary of *Juncus bufonius*, 477
- Psilotum*, Nucleoles and Centrosomes, 360
- Psorosperms, Demonstration, 130
- of Darier's Disease, 73
- Pteropoda. See CONTENTS, x
- Puccinia Paridis* and *interstitialis*, 238
- Puccinias* Parasitic on Compositæ, 238
- Pucciniæ, Fertilization, 238
- Pedicel of Teleutospores, 722
- Pulmonary Nerves of Mammalia, Staining Intrinsic, 755



- Pulmonary Sacs, Development in Arachnids, 561  
 Pulmonates, Branchiate, 670  
 Puncture Cultivations, 124  
 Purcell, F., Eye of Phalangidae, 562  
 — Eyes of Harvestmen, 335  
 Purjewicz, M. K., Formation and Decomposition of Organic Acids, 594  
 Pycnogonida, Irish, 562  
 Pyelonephritis due to *Staphylococcus pyogenes aureus*, 613  
 Pygidium of *Triarthrus*, Appendages, 335  
 Pyogenic Cocci, Mixed Infection from, 248  
 — Microbes, Influence of Light on, 492  
 — Staphylococci, Physiological Effect of Soluble Products of, 610  
 Pyrenomycetes, Classification of, 601  
*Pyrrhocoris apterus*, Red Pigment, 559
- Q.
- Quercus*, Cupule, 80  
 Queva, C., Anatomy of *Ataccia*, 362  
 — — of Stem of Dioscoreaceæ, 78  
 — Bulbils of Dioscoreaceæ, 83  
 Quince, —, Amœba-enteritis, 696  
 Quinine, Sulphate of, *Aspergillus* developing in, 380
- R.
- Rabbit, Anthrax in, 501  
 — Development of Wolffian Body in, 36  
 Rabbits, Development of *Coccidium oviforme* in Bile-duct, 355  
 Rabenhorst's Cryptogamic Flora of Germany, 596  
 Rabl, C., Methods for Examining Embryological Material, 752  
 Raciborski, M., Chromatophily of Nuclei of Embryo-sac, 473  
 — Contents of Trichomes of *Myriophyllum*, 76  
 — Development of Elaioplasts in Liliaceæ, 467  
 — Morphology of Cabombaceæ and Nymphaeaceæ, 588  
 — Nucleus of Germinating Seeds, 74  
 — Staining-differences of Male and Female Cells, 277  
 Racovitz, E. G., Amœbocytes and Oogenesis in *Micronereis variegata*, 199  
 — Ascothoracida, 197  
 — Copulation of Cephalopoda, 554  
 — Fecundation of *Octopus vulgaris*, 554  
 — Habits of *Pilumnus hirtellus*, 567  
*Radiofilum* g. n., 485  
 Radula, Growth Changes, in Land Mollusca, 182  
 Rainfall, Protection of Leaves against Excessive, 82
- Ramon y Cajal, S., Cox's Method for Demonstrating Nerve-fibres of Central Nervous System, 134  
 — Minute Structure of Nerve-centres, 325  
 Ramsden's Screw Micrometer, Aluminium, 286  
 Ransome, A., Influence of Natural Agents on Virulence of Tubercle Bacillus, 726  
*Raphidium*, Development, 605  
 Rath, O. vom, Number of Chromosomes in Animal-cells, 549  
 — Spermatogenesis in *Salamandra maculosa*, 177, 271  
 Rats, Anthrax in, 246  
 — Inoculation Apparatus for, 125  
 Rattone, G., Micro-organisms, with special regard to Etiology and Prophylaxis of Infective Diseases, 614  
 Rattray, J., Preserving Tow-net Material, 759  
 Raunkiaer, C., Cross-pollination and Self-pollination, 589  
 — Distribution of Seeds of Cyperaceæ, 368  
 — Parasitic Fungi, 379  
 Ravaz, L., Parasitic Fungi, 601  
*Ravenelia*, 490  
 Rays, Nerve-cord, 326  
 Re, L., Spherocrystals of *Agave*, 704  
 Reagents, Hardening, Changes caused in Nervous Tissue by, 642  
 Reehinger, C., Divisibility of Organs, 363  
 Reed, M., Cross- and Self-pollination, 709  
 Reeves, J., Centrospheres in Spores of *Pellia*, 581  
 — Stem and Leaves of *Physotium*, 375  
 Refractive Indices of Media, Measuring, 655, 764, 771  
 Regeneration in *Obelia*, 459  
 Reh, L., Inheritance of Acquired Characters, 176  
 Reibisch, J., *Trichosomum strumosum*, 64  
 Reiche, K., Anatomical Characters of Cæspitose Plants, 79  
 Reichel, P., Development of Bladder and Urethra, 174  
 Reichenbach, H., Incubator for any source of Heat, 516  
 Reichert's Microscope for Measurement of Growth of Plants, 103  
 — Microtome for Brain-sections, 636  
 Reinecke, F., Vernation in Compositæ, Campanulaceæ, and Lobeliaceæ, 222  
 Reinitzer, F., Fatigue-substances, 361  
 Reinke, F., Minute Structure of Cell, 43  
 Rejuvenescence in Siphonæ, 485  
 Remy, L., Researches on Bacillus of Eberth-Gaffky; Distinctive Characters of Bacillus of Typhoid Fever; Method for finding in Drinking Water, 614  
 Renal Organs of Chitons, 440, 556  
 Repiachoff, W., Spermatogenesis of Turbellaria, 65  
 Report of the Council for 1893, 148



- Reproduction among Ascomycetes, Sexual, 719  
 — in Freshwater Turbellaria, Asexual, 685  
 — in Ustilagineæ, Sexual, 719  
 — of Foraminifera, 353  
 — of *Noctiluca miliaris*, 693  
 — of Phanerogams. See CONTENTS, xxii  
 Reproductive Apparatus of *Elysia*, 180 †  
 — Organs, Male, Absence in two Hermaphrodite Molluscs, 46  
 — — of Beetles, Male, 673  
 Reptiles, Development of Bulbus cordis in, 664  
 Resedaceæ, Localization of Active Principles in, 218  
 Resin-canals in *Abies pectinata*, 585  
 Resiniferous Cell in Yew, 586  
 Resins, Formation, 372  
 Respiration Figures of Mobile Bacteria, 242  
 — in Muscinæ, 715  
 — of Phanerogams. See CONTENTS, xxiv  
 Respiratory Movements of Coleoptera, 55  
 Reticulated Tissue, Structure, 44  
 Retterer, E., Zellner's Method of Natural Injection, 641  
 Revision of Aleyonaria Stolonifera, 690  
 — of Hyalonematidæ, 70  
 — of Lumbricidæ, 683  
*Rhabdogonium excavatum*, 160  
 — *Maertensi*, 160  
 — *tricarinatum* var. *acutangulum*, 159  
 Rheumatism, Microbes in Chronic, 243  
 Rhine Country, Algæ, 89  
 — Rotifers, 67  
 — Upper, Winter Fauna of, 440  
 Rhizobes, 490  
*Rhizocrinus Santagatai*, 349  
*Rhododendron*, Sclerote, 602  
 Rhumbler, L., Enclosure of *Globigerina* by *Orbulina*, 464  
 — *Saccamina*, 695  
 Rhynchophorous Coleoptera, Tertiary, of United States, 674  
 Rhythmic Growth, 228  
 Ribbert, —, Parasites of Cancer, 699  
 Rich, J. G., Myology of *Palinurus Edwardsi*, 57  
 Richter, J., Action of External Influences on Characeæ, 716  
 — P., *Chaetomorpha Henningsii*, 91  
*Ricinus*, Germination, 230  
 Rieder, —, Atlas of Clinical Microscopy of Blood, 136  
 Rimpach, A., Waviness of Cell-wall of Exoderm of Roots, 360  
 Ringworm in Man, 97  
 Rio y Lara, D. L. del, Manual of Technique, 396  
 Ritter, W. E., Larva of *Balanoglossus*, 204  
 — Parasite of *Perophora annectens*, 692  
 — *Perophora annectens*, 672  
 Rittershausen, P., Anatomy of Acalyphææ, 78  
 Robertson, C., Cross-pollination and Self-pollination, 225, 589  
 — W. G. A., Kate of Fermentation of Sugars, 504  
 Rochebrune, A. T. de, Brooding Habits of *Octopus Digueti*, 328  
 Rocks, Formation and Erosion by Algæ, 597  
 — New Machine for cutting Thin Sections, 533  
 Rodents, Milk Dentition, 542  
 Rodet, E. and N., Microbicidal Action of Gallanol, 527  
 Römer, F., New Vorticella, 71  
 Röntgen, W. G., Experiments with Right-angled Prism, 742  
 Röse, C., Dentition of Wombat, 37  
 — Development of Teeth in Adder, 435  
 — — — in Fishes, 546  
*Ræstelia cancellata*, Malformations produced by, 234  
 Rohrer, F., Antibacterial Action of Oxychinaseptol, 268  
 Roll Tubes, Esmarch's, Distribution of Bacteria Colonies in, 529  
 Romanes, G. J., Germination of Seeds, 476  
 — Heliotropism, 480  
 Roos, E., Amœba-enteritis, 696  
 — Infusoria of Diarrhœa, 463  
 Root, Growth, 85  
 — -hairs, 707  
 — — Parasitic Growths, 763  
 — of Arborescent Liliaceæ, 221  
 — Parasitic Loranthaceæ, 473  
 — -suckers, Blind, of Swamp-forests, 365  
 — -tubercles of *Arachis*, 707  
 — — — *Isopyrum*, 587  
 — — — Leguminosæ, 586, 707  
 — -tubers, 223  
 Roots, Amount of Water Absorbed, 711  
 — of Epiphytes, Aerial, 588  
 — Orchidææ, Aerial, 473  
 — Waviness of Cell-wall of Exoderm of, 360  
 Rosa, D., Revision of Lumbricidæ, 683  
 Rosen, F., Botanical Microtechnique, 632  
 Ross "Eclipse" Microscopes, 507, 734, 762  
 — H., Leaves of Iridææ, 222  
 Rossi, F. G., Bacteriological Technique, 524  
 Rostrup, E., Parasitic Fungi, 379  
 Rotatoria of Michigan, 574  
 Rotifera of Württemberg, 456  
 Rotifers, Alpine, 67  
 — New, 67  
 — Notes on, 346  
 — of the Rhine, 67  
 Roulet, C., Anatomy of Stem of *Thunbergia*, 705  
 Roux, W., Experimental Embryology, 34, 320  
 — Interactions between Cell-substance and Nucleus, 43

- Rubiaceæ, Anatomy, 471  
 Rubner, —, *Vibrio Berolinensis*, a new Comma Bacillus, 102  
 Ruffer, M. A., Parasites of Cancer, 699  
 — Parasite of Vaccinia and Variola, 697  
 Ruge, G., Vegetative Organs of Hepaticæ, 375  
 Russell, H. L., Bacterial Flora of Atlantic Ocean, 608  
 Rust, Removal from Instruments, 743  
 Ryder, J. A., Correlations of the Volumes and Surfaces of Organisms, 667  
 — Growth of *Euglena* confined to Two Dimensions of Space, 692
- S.
- Sabatier, A., Spermatogenesis in Decapod Crustacea, 193, 272  
 Sabouraud, R., Ringworm in Man, 97  
 Sabrazès, J., Remarks on Histological and Bacteriological Technique, 121  
*Saccamina*, 695  
*Saccharomyces*, New Zymogenous, 95  
 — Spore-forming, 722  
 Saccharomycetes, Recent Researches, 488  
 Saccharose, Production in Germination of Barley, 230  
 Saccus vasculosus, Development in Teleostei and Amphibia, 665  
 Sachs, J., Mechanomorphosis, 591  
 — Periods of Growth and Causes of Development, 369  
*Sacoglossa*, Morphology, 180  
 Sadebeck, R., Exoasceæ, 487  
 Säuger, —, Removal of Rust from Instruments, 743  
 Sagami Bay, New Hexactinellids from, 691  
 Sagitta, Food, 456  
 Sahara, Symbiosis of *Heterodera radicecola* with Plants cultivated in, 477  
 St. Joseph, —, de, Polychæta of Dinard, 782  
 Saint-Remy, G., Relations of Notochord and Hypophysis in Birds, 544  
 — Severin, D. B., Red Cocco-bacillus of Sardine, 389  
 Sakharoff, N., Composite Cilia of Bacillus, 384  
 — Hæmatozoa of Birds, 357  
 — Influence of Cold on Vitality of Malaria Parasites, 357  
 — Structure of Nucleus of Crescentiform Bodies of Malaria, 466  
 Sala, L., Experiments with Ova of *Ascaris*, 201  
*Salamandra maculosa*, Spermatogenesis, 177, 271  
 Salensky, W., Metamorphosis of *Distaplia magnilarea*, 330  
 Salivary Glands of Crabrionidæ, 334  
 Salivary Glands of Hymenoptera, 189  
 — Ichneumonidæ, 445  
*Salpa*, Eyes and Subneural Gland of, 183  
 — Visual Organ, 331  
 Salpæ of Berlin Museum, 183  
 Salt, Saturated Solution, Fungus Growing in, 92  
*Salvinias*, Fossil, 595  
 Salvioli, J., Physiological Effect of Soluble Products of Pyogenic Staphylococci, 610  
 Samassa, P., Nerves of Oculiferous Tentacle of *Helix pomatia*, 440, 531  
 Sanarelli, J., Cultivating Vibrios, 127  
 — Water Vibrios and the Etiology of Cholera, 101  
 Sander, —, Tunicata collected, 183  
 Sanders, A., Examination of Nervous System of *Myzine glutinosa*, 631  
 Sandias, A., Termite Societies, 190  
 Sanfelice, F., Anaerobic Micro-organisms, 493  
 — Influence of Physico-Chemical Agents on some Pathogenic Anaerobes of the Soil, 387  
 — Researches on Anaerobic Micro-organisms, 102  
 Santori, S., Transitory Variety of Cholera Vibrio, 498  
 Sap, Ascent, 593  
 — Capillarity and Ascent, 87  
 Saposchnikoff, W., Accumulation of Carbohydrates in Leaves, 217  
 Sapotaceæ, Anatomy of Leaves, 223  
 Sappin-Trouffy, —, Pseudo-fecundation in Uredineæ, 238  
 — — — Suckers of Uredineæ, 237  
 Saprolegniaceæ, Erysiphea-like Fructification in, 600  
*Sapromyces*, 486  
 Saprophytic Fungus becoming Parasitic, 92  
 Sarcoma Parasites, 698  
 Sarcomatous Tissue, Parasitic Cell-inclusions in, 213  
 Sarcopitidæ, Parthenogenesis in Plumicolous, 448, 677  
 Sarcosporidia of Gecko, Sheep, and Swine, 72  
 Sardine, Red Cocco-bacillus of, 389  
 Sars, G. O., Caspian Crustacea, 679  
 Sasaki, C., New Heliozoon, 70  
 Saturniidæ, Transformations, 559  
 Saunders, E. R., Rôle of Acid in Protozoan Digestion, 462  
 Sauvageau, C., Leaf of Butomaceæ, 366  
 — Propagation of *Potamogeton*, 591  
 Sawtschenko, —, Cancer Parasite, 356  
 — Microchemical Staining Reactions of Mucin, 407  
 Seagliosi, G., Experiments as to Vitality of Anthrax Spores in Earth and Water, 527

- Scales of Lepidoptera and Coleoptera, Pigmentation, 186
- Scenedesmus*, 381
- *alternans* var. *apiculatus*, 16
- Schaepfi, T., Chloragogen of *Ophelia radiata*, 341
- Schaffer, J., Glass Receptacle for Series of Sections, 754
- Histology and Histogenesis of Striped Muscle, 550
- Method for Histological Examination of Osseous Tissue, 130
- Schaper, A., Development of Cerebellum in *Telcostei*, 547
- Schaudinn, F., *Myxotheca arenilega*, 212, 273
- Reproduction of Foraminifera, 353
- Schenck, H., Flexibility of Stem of Climbing Plants, 362
- Young Form of Gymnosperms, 471
- S. L., Manual of Bacteriology, 502
- Schepilevsky, E. A., Hot-water Thermostat with Automatic Regulator, 125
- Scherffel, A., Improvement in J. af Klercker's Arrangement for Cultivating Living Organisms under Microscope, 396
- Schewiakoff, W., *Achromatium oxaliferum*, 239
- Parasites of Cyclopidae, 71
- So-called Excretory Granules of Infusorians, 352
- Schickhardt, H., Effect of Sunlight on the Human Organism and on Microorganisms, 607
- Schiefferdecker, P., New Double-knife, 403
- Schilbersky, C., Dimorphism of the Flowers of *Convolvulus arvensis*, 84
- Parasitic Fungi, 93
- Schild, —, Formalin as Test for Typhoid Bacillus, 268
- Schilling, A. J., Formation of Mucilage by Aquatic Plants, 585
- Schinkewitsch, W., Endosternite of Arachnids, 55, 448
- Genetic Relations of Metazoa, 327
- W. M., Pantopoda of Albatross Expedition, 193
- Schimmelbusch, C., Pigment production of *B. pyocyaneus* in Symbiosis with other Organisms, 495
- Schips, K., Cuticular Formations, 584
- Cuticle of Seeds of Papilionaceae, 81
- Schizanthus*, Mechanism of Flowers, 712
- Schizomycetes. See CONTENTS, xxviii
- Schizophyceae. See CONTENTS, xxvii
- Schizopoda, Pelagic, 679
- Schizosaccharomyces octosporus*, 602
- Schizymenia*, 598
- Schlagenhafer, —, Cultivating Gonococcus, 749
- Schleichert, F., Diastatic Ferment, 713
- Schlosing, T., Assimilation of Free Nitrogen by Plants, 86
- Exchange of Carbon Dioxide and Oxygen, 711
- Schlosser, H., Urine-Agar for Cultivating Diphtheria Bacillus, 128
- Schmeil, O., Genus *Cyclops*, 58
- Harpacticidae, 339
- Schmid, R., Embryo of Phanerogams, 588
- Schmidle, W., Algæ of Black Forest and Rhine Country, 89
- *Radiofilum*, a New Genus of Chlorophyceae, 485
- Schmidt's Atlas der Diatomaceen-Kunde, 240
- Schmidt, A., Sputum as Cultivation Medium for Pneumonia Cocci, 271
- Staining Reactions of Sputum, 534
- F., Cleavage and Germ-Layer-Formation in Stylommatophora, 668
- P., Structure of *Pauropus*, 447
- Schmitz, F., *Actinococcus*, 376
- *Schizymenia*, 598
- Schneider, A., Plasomes, 360
- Rhizobes, 490
- Root-tubercles of Leguminosæ, 586
- Symbiosis of Algæ and Bacteria with Cyceas, 478
- Schneider's Pore in Nematodes, 63
- Scholl, H., Bactericidal Properties of Potash-Albumen, 493
- Scholtz, M., Movements of Flower-stalk of *Cobæa*, 229
- Schrakamp, —, Defensive Powers of Animal Organism against Bacilli, 733
- Schrenk, H., Parasitism of *Epiphegus*, 586
- Schroeder, H., Production of Exact Micro-meter-Screws, 252
- Schröter, J., History of Development of Uredineæ, 603
- Schüller, —, Microbes in Chronic Rheumatism, 243
- Schütt, F., Relationship between the Morphology and Biology of Diatoms and their Classification, 382
- Schulze, E., Chemistry of Cell-wall, 216
- Chemistry of Cell-wall, 583
- F. E., Hexactinellid Spicules, 352
- Revision of Hyalonematidae, 70
- Schumann, K., Development of Flowers of *Crocus*, 472
- Schunck, E., Chemistry of Chlorophyll, 702
- Schutz, J. L., Rapid Method for making Nutrient Agar, 750
- Schwendener, S., Ascent of Sap, 593
- Relation between Tension and Growth in Length, 369
- Schwenitz, E. A. de, Culture media for Biochemic Investigations, 124
- Selavo, —, Method for Staining Flagella, 405
- Scleroblasts, Origin, 661



- Sclerote-forming Species of *Penicillium*, 720  
 — in Alder-fruit, 720  
 Sclerote of *Rhododendron*, 602  
*Scorpio*, Endosternite, 192  
 Scorpion, Development, 677  
 Scott, T., Entomostraca from Gulf of Guinea, 680  
 Scourfield, D. J., Entomostraca of Wanstead Park, 567  
 Screen, New Monochromatic Light, 141  
 164  
 Screens, Lovibond's Coloured, 138  
 Screws, Micrometer, Production, 252  
 Scudder, S. H., Orthoptera of Galapagos, 55  
 — Tertiary Rhynchophorous Coleoptera of United States, 674  
 — Tertiary Tipulidæ, 446  
 Scurf, Wrinkle-, 380  
*Scutigera coleoptrata*, Eyes of, 335  
 Section-stretcher, New, 132  
 Sedgwick, A., Collection of Microscopic Preparations, 760  
 — Von Baer's Law and Significance of Ancestral Rudiments in Embryonic Development, 433  
 Seed, Development, 80, 81  
 — Influence of Pollen on, 368  
 — of Grasses, Aleurone-layer in, 78  
 Seedlings, Chlorophyll-grains in, 584  
 — of Coniferae, 220  
 — Proteolytic Ferments in, 704  
 Seeds, Causes of Disappearance of Reserve Food-materials from, 371  
 — Chlorophyll in, 584  
 — Flax-, Mucilage-layer in, 78  
 — Germinating Metastasis and Respiration in, 370  
 — Germination, 476  
 — — of Dormant, 368  
 — Influence of Light on Germination, 590  
 — Localization of Fatty Oils in Formation, 468  
 — Nucleus of Germinating, 74  
 — of *Areca Catechu*, Rumination, 706  
 — of Cyperaceæ, Distribution, 368  
 — of Papilionaceæ, Cuticle of, 81  
 Seeliger, O., Formation of Mantle, 50  
 — Origin of Peribranchial Cavity in Ascidian Embryos, 50  
 — So-called Segmentation of Tail in Appendicularia, 442  
 Seelmann, H., Rapid Staining of Blood-corpules, 756  
 Ségall, B., Demonstrating Intercalary Rings of Nerve-fibres, 133  
 Segmentation of *Limulus*, Artificial, 336  
 — So-called, of Tail in Appendicularia, 442  
 Seitz, A., Reproduction in Butterflies, 559  
 Selachian Head, Development, 548  
 Selachii, Embryogeny, 175  
 Selachii, Origin of Vascular System, 42  
*Selaginella*, Megaspore and Female Prothallium of, 594, 632  
 — Siliceous Deposit in, 88  
 — Stem, 595  
*Selenosporium aqueductum*, 724  
 Seminal Receptacle of Wasp, 674  
 Semi-Apochromatic 1/15 Objective, Kóristka, 737  
 Sensory, Antennary, Organs of Insects, 185  
*Sepia*, Shells, 553  
 Septa, Direction in Protozooids, 486  
 Septal Glands of Oligochaeta, 682  
 Sero-Amniotic Connection and Fœtal Membranes of Chick, 663  
 Serum, Sporicidal Action, 728  
 Setchell, W. A., Laminariaceæ, 90  
 Sex-cells, Origin in *Hydractinia*, 576  
 Sexual Orifices, Pteropods with two Separate, 555  
 — Reproduction among Ascomycetes, 719  
 — — in Ustilagineæ, 719  
 — — in Fungi, 485  
 Shaw, W. B., *Pleodorina*, a New Genus of Volvocineæ, 717  
 Shearer, J. B., 282  
 Sheep, Adult Cestodes of, 345  
 — Sarcosporidia of, 72  
 Shell Cavity of Philinidæ, 182  
 Shells, Marine, of British Columbia, 328  
 — of *Sepia*, *Spirula*, and *Nautilus*, 553  
 Sherborn, C. D., Index to Foraminifera, 354  
 Shipley, A. E., Collection of Microscopic Preparations, 760  
 Shrew, Placentation, 321  
 Shrubs, Medullary Rays of Dicotyledonous, 470  
 Shrubsole, W. H., 418  
 Siebel, J. E., Bacteriological Examination of Air, 280  
 Sight, Insect, and the Defining Power of Composite Eyes, 443  
 Sigillaricæ, Classification, 374  
 Siliceous Deposit in *Selaginella*, 88  
 Silicified Thickening of Cell-wall, 75  
 Silk, Formation, 334  
 Silkworm Diseases, *Streptococcus Bombycis* and, 243  
 Silurian Crinoids, 68  
 Silver Stain, Modification of Golgi, 755  
 Simmons, O. L., Development of Lungs of Spiders, 676  
 Sinistral Gastropod, Reversal of Cleavage, 669  
*Siphonaria*, 47  
 Siphonæ, Rejuvenescence in, 485  
*Sipunculus*, Gill-like Organs, 683  
 Siréna, S., Experiments as to Vitality of Anthrax Spores in Earth and Water, 527  
 Sittman, —, *Bacterium coli commune* in Living Blood, 500



- Skeletal Rudiments, Ectodermic Origin, 35  
 Skin Cancer, Parasite, 355  
 — Fungi, Natural Pure Cultivations, 530  
 Slides. See CONTENTS, XXXV  
 Slugs, Check-List, 183  
*Smerinthus populæ*, Sexes of Larvæ, 188  
*Smilacina*, Endosperm of, 588  
 Smirnow, A., Free Nerve-endings in Epithelium of Earthworm, 568  
 Smith, E. A., Indian Deep-sea Mollusca, 668  
 — J. L., New Method of Preparing Culture Media, 524  
 — R., 768  
 — T., Coarse and Fine Spirilla in Gut of Pig, 731  
 — Gas and Acid Production by Bacteria, 384  
 — T. F., Ultimate Structure of *Pleurosigma angulatum*, 141  
 Snail, Kidney, 182  
 Snow Crystals, Photomicrograms, 741  
 — Flora of Spitzbergen, 605  
 Sobotta, J., Fertilization in Mouse, 174  
 Soil, Influence of Physico-Chemical Agents on some Pathogenic Anaerobes of, 387  
 Soldier of *Eutermes*, Origin of "Nasutus," 560  
 Solleder, H., Anatomy of Rubiaceæ, 471  
 Somatopleure, Formation in Chick, 544  
 Sondermann, R., Biology of Cholera-bacilli, 614  
 Sonntag, P., Connection between Lignification, Firmness, and Elasticity in Cell-walls, 469  
 Sonsino, P., Helminthological Notes, 570  
 Sound, Production by Ants, 334  
 South American Tubificidæ, 200  
 — Australia, Land Planarians from, 202  
 Sozoioidol Preparations, Action on Cholera Bacilli, 281  
 Spain, Leeches, 343  
 Spatzier, W., Myrosin in Plants, 76  
 Spawn of *Eledone*, 555  
 Spectrum, Absorption-, of Chlorophyll, 701  
 Spencer & Smith's New 1/5 Objective, 737  
 — W. B., Victorian Earthworms, 200  
 Spengel, J. W., Enteropneusta, 203  
 Spermatogenesis in *Ascaris megalocephala*, 63  
 — in Decapod Crustacea, 193  
 — in *Salamandra maculosa*, 177  
 — of *Bombyx Mori*, 187  
 — of Crustacea, Study, 272  
 — of *Salamandra*, Investigation of, 271  
 — of Turbellaria, 65  
 Spermatozoa of *Dytiscus*, 52  
 Spermatozooids of Fucaceæ, Irritability, 599  
*Sphagnum*, Fungus-parasite of, 235  
 Spheres, Kuster's, for Microscopic Objects, 135  
 Spherocrystals of *Agave*, 704  
 Spherometer, New Exact and Easily Constructed, 107  
 Sphenophyllaceæ, Position, 595  
*Sphenophyllum*, 374  
 Spherocrystals of *Euphorbia*, 76  
 Spicule, Development of Holothurian, 457  
 Spicules, Hexactinellid, 352  
 Spider, Coelomic Cavity, 676  
 Spiders, Activity of Heart, 56  
 — Development of Lungs, 676  
 — Instincts of Common English, 55  
 Spiny Plants, 222  
 Spirilla, Coarse and Fine, in Gut of Pig, 731  
 — Demonstrating in Drinking-water, 274  
*Spirotania obscura*, Chlorophores, 90  
*Spirula*, Shells of, 553  
 Spitzbergen Expedition, Synascididæ, 671  
 — Snow-flora, 605  
*Spondylosium pulchellum*, 2  
 — — var. *pyramidatum*, 3  
 Sponges, Comparative Anatomy, 461  
 — Generic Nomenclature of Bowerbank's British, 576  
 — New, 352  
 Spongillidæ, Studies, 69  
 Sporangium of Ferns, Annulus of, 373  
 Sporangia of *Thamnidium elegans*, 600  
 Spore-formation in Liverworts, Relations of Nucleus to, 232  
 — -forming *Saccharomyces*, 722  
 — -staining after Maceration, 757  
 — — — Fiecca's Method for, 133  
 Spores, Anthrax, Experiments as to Vitality in Earth and Water, 527  
 — — Staining Nuclei of, 406  
 — Insertion in Protobasids, 486  
 — Nuclei of Anthrax, 385  
 — of Diatoms, 239  
 — of Microsporidia, 465  
 — of *Pellia*, Centrospheres in, 581  
 — of Yeast, 235  
 — — Fixing and Staining, 276  
 — Staining, 276  
 Sporadic Action of Serum, 728  
 Sporophyte of Equisetineæ and Lycopodiaceæ, 88  
 Sporoza, Classification, 71  
 Spronck, C. H. H., Cholera Vibrio of Epidemic in Holland, 731  
 Spurs of *Tropæolum* and *Pelargonium*, 363  
 Sputa, Fungus found in, 97  
 Sputum as Cultivation Medium for Pneumonia Cocci, 271  
 — Phthisical, New Method for Detecting Tubercle Bacilli in, 402  
 — Staining Reactions, 534  
 Stabilite, Use for Celloidin Preparations, 753  
 Stage Aquarium, 121  
 — Cold, 266  
 — Leitz's Mechanical, 105

- Stage, Swift's New Mechanical, 509, 539, 768  
 — Zeiss New Mechanical, 768  
 Stahl, E., Transpiration and Assimilation, 710  
 — Protection of Leaves against Excessive Rainfall, 82  
 Staining Objects. See CONTENTS, XXXV  
 Stamens of *Berberis*, Movements, 712  
 Staminal Appendages of *Aristolochia*, 80  
 Standfuss, M., Relations between Colouring and Habit in Lepidoptera, 558  
 Staphylococci, Pyogenic, Physiological Effect of Soluble Products, 610  
*Staphylococcus pyogenes aureus*, Mechanism of Virulence, 732  
 — — — Pylonephritis due to, 613  
 Starch, Conversion into Sugar by *Bacillus anthracis*, 384  
 — Formation, in *Pelargonium zonale*, 372  
 — -grains, Structure, 217  
 — Storing up and Transport of, 593  
 Starfishes, Examination, 631  
 — Recent and Fossil, 204  
 Stauffacher, H., Oogenesis and Segmentation in *Cyclops*, 330  
*Staurostrum amphidoxon*, 10  
 — *asperum*, 11  
 — *avicula* var. *subarcuatum*, 10  
 — *dejectum* subsp. *Tellamii*, 10  
 — *furcatum* var. *subseuarium*, 10  
 — *grande* var. *parvum*, 11  
 — *inconspicuum* var. *crassum*, 11  
 — *irregulare*, 12  
 — *lanceolatum* var. *compressum*, 11  
 — *lunatum* var. *subarcuatum*, 10  
 — *ophiura* var. *cambricum*, 12  
 — *pyramidatum* var. *coilon*, 11  
 — *subavicula*, 12  
 — *subpygmaeum*, 11  
 Steam Sterilizer, Behrendsen's, 266  
 Steffen, W., Importance of Saliva and Sputum for the Biology of certain Bacteria, 614  
 Steinheil, R., New Objective Setting, 509  
 Stem of Climbing Plants, Flexibility, 362  
 — Dioscoreaceæ, Anatomy, 78  
 — Grasses, 365  
 — Monocotyledons, Increase in Thickness, 469  
 — *Physiotium*, 375  
 — *Selaginella*, 595  
 — *Thunbergia*, Anatomy, 705  
 — *Wistaria sinensis*, Anatomy, 363  
 Stephani, F., New Genera of Hepaticæ, 482  
 Stereoscopic Photomicrography, 262, 393, 413  
 — Vision applied to Diatoms, 628  
 Sterilizer, Behrendsen's Steam, 266  
 — Steam, Combination Hot Filter and, 529  
 Sterki, V., Growth Changes of *Radula* in Land Mollusca, 182  
 Stichids of *Dasya*, 376  
*Stichococcus bacillaris*, 725  
 Stigma, 701  
 Stigmata in Arachnida, Vestigial, 561  
 — Arachnida, 55  
 — Larva of *Melolontha*, 54  
 Stigmatic Lobes of *Iris*, 80  
 Stiles, C. W., Adult Cestodes of Cattle, Sheep, and Allied Animals, 345  
 — Catalogue of Parasites, 667  
 — Preparation of Cestodes, 272  
 Stipules of *Euonymus*, 366  
 Stockmayer, S., Pellicle of Algæ, 89  
 Stocklin, H. de, Coli Group of Bacteria, 499  
 Stolterfoth, H., The Genus *Corethron*, 762  
 Strasburger, E., Ascent of Sap, 593  
 — Centrospheres of Nucleus and Size of Cells, 581  
 Strazza, —, Capsule Bacillus of *Ozæna*, 100  
 Strecklin, H. de, Researches on Mobility and Cilia of some representatives of the Group of Coli-Bacilli, 391  
 Street Dust, Examining for Tubercle Bacilli, 134  
 Strebl, K., Theoretical Limit to Capacity of Microscope, 263  
*Strelitzia*, Pollination, 475  
 Streptococci, 497  
 — Atmospheric, 498  
 — in Healthy and Unhealthy Mouth, 498  
*Streptococcus bombycis* and Silkworm Disease, 243  
 — *longus*, Growth in Bouillon, 611  
 — *pyogenes* in Drinking-water, 100  
 — — Liquefaction of Gelatin by, 727  
 — — Presence in Osteomyelitis and Periostitis, 245  
 Stridulating Aquatic Hemipteron, 191  
 Stroeb, H., Demonstrating Axis-cylinders, 275  
 Studer, T., Aleyonaria of 'Albatross,' 350  
 Stürtz, B., Recent and Fossil Starfishes, 204  
 Sturgeon, Development of Kidney, 325  
 Stutzer, A., Investigations on Bacteria of Rhine above and below Cologne, 102  
 — New Contrivances for Sterilizing Milk, and for Preservation of Fruits and Vegetables, 504  
 Stylummatophora, Cleavage and Germ-Layer-Formation in, 668  
 Sublimate Solutions of Anilin Dyes, Staining Tubercle Bacilli in, 276  
 Subneural Gland of *Salpa*, 183  
 Substage, New, 252  
 Suckers of Uredinæ, 237  
 Suffolk, W. T., 149  
 Sugar-cane, Diseases, 723  
 — — Nematodes and, 570  
 Sugar, Conversion of Starch into, by *Bacillus anthracis*, 384

- Sugg, E., Researches on Bacillus of Eberth-Gaffky; Distinctive Characters of Bacillus of Typhoid Fever; Methods for Finding in Drinking-water, 614
- Sulphate of Quinine, *Aspergillus* developing in, 380
- Summer Eggs of *Moina*, 196
- Sunlight, Effect on Human Organisms and on Micro-organisms, 607
- Superstage-Plate, Watson's New, 286
- Surgeons, Gedoelst's Bacteriology for Veterinary, 137
- Surgery, Bacteriology in, 608
- Surgical Infection, Microbic Origin of Purulent, 249
- Swamp Forests, Blind Root-suckers of, 365
- Swift, J., Practical Instructions for Making a Student's Microscope, 620
- Swift's (J.) Four-legged Microscope, 285, 506
- Microtome, 767
- New Histological and Physiological Microscope, 251
- New Mechanical Stage, 509, 539, 768
- Swine, Sarcosporidia of, 72
- Syllideæ, Researches, 60
- Symbiosis of Algæ and Bacteria with *Cycas*, 478
- of *Heterodera radiculicola* with Plants cultivated in Sahara, 477
- Pigment Production of *Bacillus pyocyaneus* in, with other Organisms, 495
- Symbiotic Fungus of Ophioglossaceæ, 94
- Synascididæ of Spitzbergen Expedition, 671
- Systematic Position of *Ditiola*, 723
- T.
- Tænia flavopunctata*, 687
- *Brandti*, 455
- *mediocanellata*, Growth, 688
- *nana*, 687
- Tæniæ, Structure and Life-history, 203
- Valvular Apparatus in Excretory Vesicles, 454
- Tæniidæ, Anatomy, 572
- Tail in Appendicularia, so-called Segmentation, 442
- of Appendiculariæ, Vertebration, 557
- 'Talisman' Expedition, Asteroidea, 205
- Talmage, J. E., 536
- Tannins, Formation and Function, 703
- Tanret, C., Inulin and its Allies, 217
- Tapeworm, New Human, 686
- Tardigrades, Revival, 335
- Tasmania, Land Planarians, 202
- Tavel, F. v., Alternation of Generations in Uredineæ, 237
- Taxodium distichum*, Knees, 365
- Technique. See CONTENTS, xxxii
- Tectibranchiata, Pallial Organs, 669
- Teeth, Development in Adder, 435
- — in Fishes, 546
- — in Iguana, 38
- -pulp, Bacteriology of, 727
- Succession and Genesis of Mammalian, 542
- Teissier, P. J., Study of Permanent or Facultative Properties of certain Pathogenous or Saprophytic Microbes cultivated on Coagulated Egg-albumen, 504
- Teleostean Fishes, Epiphysis, 546
- Teleosteans, Experimental Studies on Eggs, 40
- Growth of Blastoderm, 40
- Karyokinetic Phenomena in Cells of Blastoderm, 41
- Teleostei, Development of Cerebellum, 547
- — Fins, 547
- — of Hypophysis and Saccus vasculosus, 665
- — of Olfactory Organs, 665
- Teleutospores of Puccinieæ, Pedicel, 722
- of Uredineæ, 603
- Temnocephala chilensis*, 686
- Temnocephalæ, Monograph, 65
- Temperature, Influence of Low, 178
- Tempere, J., Cleaning Diatoms, 278
- Tendrils, Intertwining, 371
- Tentacle of *Helix pomatia*, Nerves of Oculiferous, 440
- Tentacles of *Apolemia uvaria*, Structure, 459
- Tentacular Nerves of *Helix pomatia*, Examination, 531
- Termite Societies, 190
- Terni, C., *Actinomyces Gruberi* sp. n., 725
- Characteristic Mobility of Typhoid Bacillus, 388
- Tertiary Rhynchophorous Coleoptera of United States, 674
- Tipulidæ, 446
- Tetanus Bacillus, Cultivation, 630
- Tetractinellidæ of Naples, 691
- Tetramitus Nitschei*, 699
- Tetrasporanges of *Dasya*, 376
- Thamnidium elegans*, Sporanges, 600
- Thaxter, R., Laboulbeniaceæ, 95
- *Sapromyces (Naegelia)*, 486
- Thélohan, P., Interrelations of Myxosporidia, 355
- Muscle Degeneration in Earbel from Presence of Myxosporidia, 72
- Spores of Microsporidia, 465
- Thelphusæ from Eastern Africa, 567
- Thermogenous Bacteria, 384
- Thermostat, Hot-water, with Automatic Regulator, 125
- Thionin, Use, 405
- Thomas, M. R., Androconia of Lepidoptera, 186
- Thompson, H., Correlation of certain External Parts of *Palæmon serratus*, 449
- I. C., Copepoda of Liverpool Bay, 450



- Thomson, W., *Puccinia Paridis* and *interstitialis*, 238
- Thoracic Legs of *Triarthrus*, 198
- Thunbergia*, Anatomy of Stem, 705
- Thymeleaceæ, Structure, 362
- Thymus, Development, 323, 436
- Thyroid Gland, Development, 323
- Tieghem, P. v., Root of Parasitic *Loranthaceæ*, 473
- Structure of Thymeleaceæ and *Pencaceæ*, 363
- Tiemann, F., Perfume of Violet, 231
- Tilden, E., Filamentous Form of *Proto-coccus*, 725
- J. E., Elaters of *Hepaticæ*, 716
- Tilia argentea*, Hairs, 367
- Timofeyewski, —, Demonstrating Nucleated Red Corpuscles, 639
- Timpe, H., Method for Imparting Correct Reaction to Nutrient Gelatin, 270
- Tipulidæ, Tertiary, 446
- Tissue, Investigation of Reticulated, 130
- Method for Histological Examination of Osseous, 130
- Tissues, Cell and Animal, 549
- of Phanerogams. See CONTENTS, xx
- Quick Double-staining Method for Examination, 639
- Tobacco, Cholera Bacillus and, 499
- -plant, Localization of Nicotine in, 361
- Todaro, F., Visual Organ of *Salpa*, 331
- Tognini, F., Female Flower and Fruit of Chestnut, 79
- Tolomei, G., Action of Magnetism on Germination, 590
- Action of Ozone on Micro-organisms, 383
- Tongue, Phylogeny, 662
- Toni, G. B. de, Interfrustular Reproduction of Diatoms, 382
- Localization of Nicotine in Tobacco-plant, 361
- Tonkoff, W., Swellings of Leaf-stalk of *Atragene*, 473
- Topsent, E., New Sponges, 352
- Torné, M. Font y. See Font y Torné
- Tourens, —, Circulatory System of *Dreissensia polymorpha*, 442
- Nervous System of *Dreissensia polymorpha*, 328
- Tow-net Material, Preserving, 759
- Toys, Isolating Bacillus of Diphtheria from, 128
- Trabut, L., Parasitic Fungi, 601
- Tracheal System of Larval Hymenoptera, 334
- — of *Locusta*, 446
- Trachytesægrola*, 313
- *pyriformis*, 313
- Trambusti, A., Physiological Effect of Metabolic Products of *B. Hydrophilus fuscus*, 495
- Tranzschel, W., *Puccinia Paridis* and *interstitialis*, 239
- Traustedt, M., Tunicata collected by Dr. Sander, 183
- 'Travailleur' Expedition, Asteroidea, 205
- Treasurer's Account, 150
- Trees, Fungus Flux of, 604
- Trelease, W., Pollination of *Yucca*, 226
- Trematode, Striated Muscular Fibres in a, 571
- Trentepohlia*, 717
- Polymorphism, 233
- Triarthrus*, Thoracic Legs, 198
- Tribromophenol - Bismuth, Action on Cholera Bacilli, 281
- Trichinosis, 65
- Trichomes of *Myriophyllum*, Contents, 76
- Trichomonas* in Urine of Men, 697
- Trichoptera, Mouth-parts, 54
- Trichosomum strumosum*, 64
- Trichosphaeria Sacchari*, 380
- Triclad, New Marine, 453
- Trigonidæ, Systematic Position, 556
- Trilobites, Systematic Position, 562
- Tristomid, New, 571
- Triton*, Median Groove, 324
- Structure of Nucleus in Ovarian Ovum, 545
- Tropæoleæ, Localization of Active Principles in, 218
- Tropæolum*, Spurs, 363
- Trouessart, E., Parthenogenesis in Plumicolous Sarcopitidæ, 448, 677
- Trout, Fecundation of Egg, 324
- Preparation of Eggs, 272
- Trout's Ovum, Fertilization, 435
- Tschirch, A., Formation of Resins and Essential Oils, 372
- Tubercle Bacilli, Examining Street Dust for, 134
- — in Lung, Technique for Studying, 401
- Bacillus, Influence of Natural Agents on Virulence of, 726
- — Mixed Infection from, 248
- — New Method for Detecting in Phthisical Sputum, 402
- — Simultaneous Double Stain for, 277
- — Staining, 640
- — — in Sublimate Solutions of Anilin Dyes, 276
- Tubercles of Papilionaceæ, Filaments, 609
- Tubers, Classification, 367
- Germinating, Metastasis and Respiration in, 370
- of *Apios tuberosa* and *Helianthus tuberosus*, 83
- Tubes formed by Annelids, 198
- Tubeuf, C. v., Parasitic Fungi, 378, 379
- Tubificidæ, South American, 200
- Tumours, Woody, Ustilago Producing, 487
- Tunicata. See CONTENTS, xi
- Turbellaria, Asexual Reproduction in Freshwater, 685



- Turbellaria-Fauna of Basle, 571  
 — 'Albatross' Expedition, 202  
 — Liverpool Marine District, 454  
 — Spermatogenesis, 65  
 Turner, W. A., Recent Methods of Staining Central Nervous System, 768  
 Tutton, A. E., Instrument for Producing Monochromatic Light of any desired Wave-length — its Use in Investigation of Optical Properties of Crystals, 394  
 Typhoid Bacillus, Characteristic Mobility, 388  
 — Bacilli, Differences between *B. typhosus* and, 388  
 — — Formalin as Test for, 268

## U.

- Ude, H., Exotic Earthworms, 200  
 Underwood, L. M., Myriopoda of North America, 447  
 United States, *Distomum Westermanni*, 345  
 — — Mesozoic Echinoderma, 689  
 — — Tertiary Rhynchophorous Coleoptera, 674  
 University, Plea for Systematic Instruction in Technique of Microscope at, 627  
 Unna, P. G., Natural Pure Cultivations of Skin Fungi, 530  
 — Simultaneous Double Stain for Leprosy and Tubercle Bacilli, 277  
 Urari, Changes Induced in Wandering Cells of Frog, 178  
 Uredineæ, Alternation of Generations, 237, 603  
 — and their Hosts, 489  
 — Germination, 380  
 — Heteroecious, 722  
 — History of Development, 603  
 — Pseudo-fecundation, 238  
 — Suckers, 237  
 — Teleutospores, 603  
 Urech, F., Pigmentation in Scales of Lepidoptera and Coleoptera, 186  
 Urethra, Development, 174  
 — of Women, Microbes in Normal, 613  
 Urinary Sediment, Collecting and Preserving, 643  
 Urine-agar for Cultivating Diphtheria Bacillus, 128  
 — of Men, *Trichomonas* in, 697  
*Urobacillus liquefaciens septicus*, 613  
*Uropoda campomolendina*, 306  
 — *elegans*, 307  
 — *hamulifera*, 298  
 — *Krameri*, 306  
 — *minima*, 307  
 — *ovalis*, 303  
 — *Ricasoliana*, 307  
 — *tecta*, 307  
 — *vegetans*, 304  
 Uropodinae, Notes, 287, 289  
*Uroseius acuminatus*, 312  
 Urticaceæ, Inflorescence, 472  
 Ury, J., Morphological and Cultural Variations of *B. coli commune*. Its Identity with *B. pneumoniæ* and Bacillus of Abdominal Typhus, 733  
 Uschinsky's Medium, Cultivation of Cholera in, 400  
 Ustilagineæ, Sexual Reproduction, 719  
 — Structure, 487  
*Ustilago* producing Woody Tumours, 487

## V.

- Vaccinia Parasite, 697  
*Vaginulina*, 421  
 — *arguta*, 425  
 — *Biochei*, 427  
 — *comitina*, 426  
 — *discors*, 426  
 — *gaultina*, 425  
 — *Priceana*, 427  
 — *recta*, 422  
 — — var. *tenuistriata*, 422  
 — *sparsicostata*, 426  
 — *strigillata*, 423  
 — *striolata*, 425  
 — *truncata*, 423  
 — — var. *robusta*, 424  
 Valvular Apparatus in Excretory Vessels of Tæniæ, 454  
 Van der Velde, H., Mechanism of Virulence of *Staphylococcus pyogenes aureus*, 732  
*Vanessa*, Development of Compound Eye, 186  
 Vängel, E., Bryozoa of Hungary, 442  
 Van Heurck Microscope, 761  
 Varigny, H. de, Experimental Nanism, 670  
 Variola Parasite, 697  
 Vascular Hyphæ of Autobasidiomycetes, 724  
 — System in Selachii, Origin, 42  
 Vasogen, Bactericidal Properties, 387  
 Vejdovsky, F., Development of Organs in Gordiidæ, 684  
 Vellosiaceæ, Anatomy, 223  
 Venation of *Cycas*, 223  
 — of Muscineæ, 596  
 Venous System of Mammals, Development, 662  
 Veretillid, New, 576  
 Verhoeff, C., *Chordeuma germanicum*, 191  
 — Classification of Iulidæ, 675  
 — Comparative Morphology of Abdomen of Lampyridæ, Cantharidæ, and Malachiidæ, 673  
 — Copulatory Organs of Male Hymenoptera, 53  
 — Cross-pollination and Self-pollination, 590  
 — Developmental Stages of Iulidæ, 335

- Vermes. See CONTENTS, xiv  
 Vernation in Composite, Campanulaceæ, and Lobeliaceæ, 222  
*Veronica hederaefolia*, Embryology, 225  
 — Movements of Flowers, 229  
 Vertebral Column, Development, 176  
 — — of Fishes, 41  
 Vertebrate Liver, Investigating Histology, 129  
 Vertebrates, Endoglobular Parasites of, Blood, 578  
 Verworn, M., Physiological Significance of Cell-nucleus, 70  
 Vesuvius, Employment for Fossil Plants, 133  
 Veterinary Surgeons, Gedoelst's Bacteriology for, 137  
 Vezey, J. J., 149, 152  
 Viability Period of Diphtheria, 248  
 Vibrio, Cholera, and Diagnosis of Cholera, 612  
 — Cholera, Artificial Variation of, 499  
 — — Blood-Serum as Diagnostic Cultivation Medium, 269  
 — — of Epidemic in Holland, 731  
 — — Transitory Variety, 498  
 — — Variations, 731  
 — Choleroïd, New Species, 498  
*Vibrio danubicus*, 247  
 Vibrio resembling Cholera bacillus, 247  
 Vibrios and Cholera, 730  
 — and Production of Lactic Acid, 494  
 — Cholera, Easy Method for Demonstrating in Water, 274  
 — Cultivating, 127  
 — Non-Albuminous Cultivation Media, 525  
 — Water, and the Ætiology of Cholera, 101  
 Vicentini, P., *Leptothrix racemosa*, 726  
 Victorian Earthworms, 200  
*Vinea major*, Germination of Pollen, 84  
 Vincent, H., Parasite of Madura Foot, 390  
 — Staining Micro-organisms in Blood, 757  
 Violet, Perfume, 231  
 Virulence of Tubercle Bacillus, Influence of Natural Agents on, 725  
 Visert, O., Alimentary Canal of Orthoptera, 445  
 Visual Organ of *Salpa*, 331  
 Vivipary, Pseudo-, of *Juncus bufonius*, 477  
 Vivisection, Microscopic, 210  
 Vöclting, H., Influence of Light on Flowers, 227  
 Vogel, H. W., Optics of Photography, 741  
 Voges, O., Chromogenic Water Bacteria, 245  
 — Cultivation of Cholera in Ushinsky's Medium, 400  
 — Growth of Cholera Bacilli on Potato, 128  
 Volpe, L., Beneficent and Maleficent Egg-Albumen, 514  
 Volvocineæ, New Genus, 717  
 Von Baer's Law. See Baer  
*Vorticella*, New, 71  
 Vorticellæ, Morbific Effect of Certain, 692  
 — Parasitic, 211  
 Vosmaer, C. G. J., Tetractinellidæ of Naples, 691  
 Vuillemin, P., Fertilization of Pucciniæ, 238  
 — Insertion of Spores and Direction of the Septa in Protobasids, 486  
 — Pedicel of Teleutospores of Pucciniæ, 722  
 — Spurs of *Tropæolum* and *Pelargonium*, 363  
 — Symbiosis of *Heterodera radiceicola* with Plants cultivated in Sahara, 477  
 — *Ustilago* producing Woody Tumours, 487
- W.
- Wager, H., Nuclear Division in Hymenomyces, 380  
 Wagner, A., Pollination of *Strelitzia*, 475  
 — J., Germinal Layers, Yolk Cells, and Embryonic Membranes of Arthropoda, 672  
 — W., Activity of Heart of Spiders, 56  
 Wahrlich, W., Anatomy of Cell in Fungi and Filiform Alge, 74  
 Waite, M. B., Pollination of Pear, 710  
 Wakker, J. H., Cultivation Capsule for Fungi, 746  
 Waldvogel, R., Growth of *Streptococcus longus* in Bouillon, 611  
 Walker, E., Cross- and Self-Pollination, 709  
 — J. J., Terrestrial Fauna of Damma Island, 552  
 Walking of some Arthropoda, 557  
 Wallace, A. R., Zoological Regions, 437  
 Walliczek, H., Mucilage of Membrane of Vegetative Organs, 219  
 — Technique of Disinfection Experiments, 528  
 — Testing Resistance of *Bacterium coli commune* to Drying, 528  
 Wanstead Park, Entomostraca from, 367  
 Warburg, O., Influence of Lignification on Life of Cell, 218  
 Ward, H. B., *Distonum Westermanni* in United States, 345  
 — H. M., Action of Light on Bacteria, 241  
 — Assimilation of Nitrogen by Plants, 478  
 Warham, A. E., Variations in the Dorsal Tubercle of *Ascidia virginea*, 557  
 Warming, E., Anatomy of Vellosiaceæ, 223

- Washburn, F. L., Examination of Eggs of *Limax maximus*, 531
- Wasp, Seminal Receptacle, 674
- Wasps, Reproduction, 190
- Wassiliewsky, —, Protozoa in Herpes Zoster, 462
- Water, Amount absorbed by Roots, 711
- Apparatus for Boiling and Cooling, 267
- Bacteria, Chromogenic, 245
- — Diagnosis, 136
- Drinking-, *B. coli commune* and *B. typhosus* in, 99
- Demonstrating Protozoa and Spirilla in, 274
- — *Streptococcus longus* in, 100
- Disease in Fresh, 726
- Easy Method for Demonstrating Cholera Vibrios in, 274
- Examining, for Anaerobic Bacteria, 527
- Experiments as to Vitality of Anthrax Spores in, 527
- Mains of Paris, Mollusca, 182
- Microbes, Pathogenic Properties, 385
- Micro-organisms, Duration of Incubation on Gelatin, 494
- Sea-, Action on Microbes, 727
- Spontaneous Purification of River, 714
- Supply, Chicago, Organisms in, 328
- -vascular Systems of Asteroidea, 574
- Vibrios and Ætiology of Cholera, 101
- Watson, A. T., Habits of Amphictenidæ, 567
- Watson's Aluminium Abbe Camera Lucida, 286
- — Ramsden's Screw Micrometer, 286
- New Superstage-plate, 286
- Van Heurck's Microscope, 761
- Wawrzik, E., Supporting Tissues of Nervous System of Chætopoda, 198
- Weber, L., Chromatic Aberration of Lenses, 116
- Webster, F. M., Parasitic Fungi, 601
- Wehmer, C., Development of *Penicillium luteum*, 379
- Function of Citric Acid in Assimilation, 230
- Fungi which produce Citric Acid, 235
- Parasitic Fungi, 489
- Sclerote-forming Species of *Penicillium*, 720
- Weigert's Fibrin Method, 407
- Weismann, A., Effect of External Conditions on Development, 434
- Weisse, A., Mechanical Theory of Phyllo-taxis, 706
- Weldon, W. F. R., Correlated Variations in *Carcinus Mænas*, 195
- Weltner, W., Studies on Spongillidæ, 69
- *Tetramitus Nitschei*, a Parasite of Gold-fish, 699
- Tunicata collected by Dr. Sander, 183
- Wendt, G., Chemistry of Protoplasm, 45
- Went, F. A. F. C., Aerial Roots of Epiphytes, 588
- Diseases of the Sugar-cane, 723
- Werigo, —, Anthrax in Rabbit and its Lessons, 501
- Werner, F., Alimentary Canal of Orthoptera, 560
- Phenomena of Convergence, 179
- Wernicke, —, Cholera Bacillus and Tobacco, 499
- Wertheim, —, Bacteriology in Surgery, 608
- Wesener, —, Preparation of Nutrient Medium for Bacteria from Eggs, 399
- West, W., New British Freshwater Algæ, 1
- Westermaier, M., Embryology of Flowering Plants, 224
- Weylandt, J., Anatomy of Galegææ, 362
- Wheeler, W. M., New Marine Triclad, 453
- *Planocera inquilina*, 452
- Protandric Hermaphroditism in *Myzostoma*, 456
- White, T. C., 151, 283, 537
- Whitman, C. O., Eye of *Clepsine*, 62
- Wichmann, H., Cultivating Ascospores, 127
- Wick, Clay, 738
- Widenmann, —. von, Hairs of *Tilia argentea*, 367
- Wieler, A., Stoppages of Vessels, 77
- Wiese, —, Preservative Fluid for Animals, 277
- Wiesner, J., Influence of Chemical Intensity of Light on Growth of Plants, 475
- Microscope for Measurement of Growth of Plants, 103
- Wilcox, E. M., Histology of *Pontederia*, 586
- Wildeman, M. E. de, *Chlorocystis*, 92
- Formation of Cell-walls, 360
- *Lagenidium* and Chytridiacææ, 377
- New Genera of Fungi, 378
- New *Pleurococcus*, 382
- *Scenedesmus*, 381
- *Trentepohlia*, 717
- Willach, P., *Balantidium viride*, an Infusorium Pathogenic to Pigeons, 211
- Willem, V., Structure of Tentacles of *Apoletia uvaria*, 459
- Willey, A., Evolution of Præoral Lobe, 330
- Williamson, H. C., Bifid Earthworms, 343
- Willis, J. C., Fertilization of *Claytonia*, *Phacelia*, and *Monarda*, 84
- Wilson, H. V., Embryology of Porifera, 461
- Wine, Artificial Colouring with Vegetable Substances, 756
- Presence of Mannite in, 373
- Yeasts, 720

- Winkler, F., Preparing Sections of Living Cultivations without previous Hardening, 273
- Winogradsky, S., Assimilation of Atmospheric Nitrogen by Microbes, 97  
— Assimilation of Nitrogen by Plants, 478
- Winter Eggs of *Moina*, 196  
— Fauna of Upper Rhine, 440
- Winterstein, E., Vegetable Amyloid, 76
- Wistaria sinensis*, Anatomy of Stem, 363
- Witch-broom of Fir, 470
- Witting, F. C., *Chlorocystis*, 92
- Wöhrmann, S. von, Systematic Position of Trigonidae, 556
- Wörnle, P., Injuries produced by *Gymnosporangium*, 601
- Wolf, *Filaria immitis* in Japanese, 65
- Wolffhügel's Colony Counter, Modification, 529
- Wolfian Body, Development in Chick and Rabbit, 36
- Wombat, Dentition, 37
- Women, Microbes in Normal Urethra, 613
- Wood at bounds of Annual Growth, 704
- Wood, Optical Properties, 519
- Wood, Secondary, of Apetalæ, 220
- Woods, C. D., Assimilation of Free Nitrogen by Plants, 86
- Woodward, M. F., Milk Dentition of Rodents, 542  
— Succession and Genesis of Mammalian Teeth, 542
- Woodworth, W. M.M., Turbellaria of 'Albatross' Expedition, 202
- Worm, Tape-, New Human, 687
- Worms, Cerebral Physiology, 681  
— Cystic, of *Bothriocephalus* in German Fishes, 346
- Woronina*, 718
- Wortmann, J., Inspissated Must and Cultivation of Fungi, 270
- Wright, J. S., Cell-union in Herbaceous Grafting, 85  
— S. G., Leaf-movement in *Cercis*, 712
- Wrinkle-scurf, 380
- Württemberg, Rotifera, 456
- Wurtz, —, Germicidal Properties of Human Mucus, 268
- X.
- Xamben, —, Metamorphoses of Insects, 558
- Xanthidium antilopæum* var. *lawe*, 8
- Y.
- Yeast, Effront's Process for Purification and Preservation, 236  
— Fixing and Staining Nuclei and Spores, 276  
— Spores, 235
- Yeasts, Action on Glycogen, 721  
— Histological Structure and Development, 95  
— Pure-bred, Fermenting Grape- and Apple-must with, 235  
— Structure and Development, 721  
— Wine-, 720
- Yersin, —, Bacillus of Bubo Plague, 730
- Yew, Muciferous and Resiniferous Cells in, 586
- Yolk-cells of Arthropoda, 672  
— -nuclei in Meroblastic Ova, 435  
— -nucleus in *Cymatogaster aggregatus*, 548
- Yucca*, Pollination, 226
- Z.
- Zabriskie, J. L., Endosperm of *Phytelephas* and *Smilacina*, 588
- Zacharias, E., Growth of Cell and Nature of Nucleus, 582  
— Structure of Cells of Phycchromaceæ, 241  
— O., Distribution of Lacustrine Plankton, 552
- Zehntner, L., Crustacea of Malay Archipelago, 563
- Zeiler, R., *Sphenophyllum*, 374
- Zeiss, New Mechanical Stage, 768
- Zelinsky, N., Microbes which evolve Hydrogen Sulphide, 492
- Zellner's (K.) Method of Natural Injection, 641
- Zenker, K., Fixative, 758
- Zenthofer, —, Characters of Cholera-cultivations on Fowl's Eggs, 614  
— Cultivating Cholera on Eggs, 526
- Zentmayer's Portable Microscope, 771
- Zettnow, —, Cleaning Dirty Slides and Cover-glasses, 535  
— Cleaning New Cover-glasses, 135
- Ziegenbein, E., Metastasis and Respiration in Germinating Tubers and Seeds, 370
- Ziegler, H. E., New Compressorium, 759  
— Yolk-nuclei in Meroblastic Ova, 435
- Zimmermann, A., Behaviour of Nucleoles during Karyokinesis, 583  
— Botanical Micro-technique, 523  
— Cell-structure, 214  
— Chromatophores, 584  
— Cilia and Pseudo-cilia, 701  
— Elaioplasts, 76  
— — and Elaiospheres, 704  
— Excretions of Calcium Phosphate, 77  
— Eye-spot, 701  
— Function of Nucleus, 582  
— Growth of Cell-wall, 467  
— Kuster's Hollow Spheres for Microscopic Objects, 135  
— Proteinaceous Crystalloids, 468



- Zimmermann, A., Silicified Thickening of Cell-wall, 75  
 — Staining Crystalloids of Cell-nuclei, 275  
 — H., Comparison of Duramen and Alburnum, 219  
 Zoja, L. and R., Altmann's Bioplasts, 326  
 Zoologischer Anzeiger, Index, 49  
 Zoospores of *Draparnaldia*, 91  
 Zopf, W., Brefeld's Mesomycetes, 719  
 — Development of *Dictyosphaerium*, 605  
 — Low Animal and Vegetable Organisms which appear as producers of disease in Algæ, Fungi, Lower Animals and Higher Plants, 733  
 Zopf, W., Myxomycetes in *Saccamina*, 696  
 — New Genera of Chytridiaceæ, 718  
 — Pigments of Fungi, 600  
 — *Woronina*, 718  
 Zoth, O., Cooling of Projection Preparations, 112  
 Zukal, H., Fungus growing in a Saturated Solution of Salt, 92  
 — New Genera of Fungi, 92  
 — Parasitic Fungi, 489  
 — Protoplasts of Cyanophyceæ, 383  
 — Saprophytic Fungus becoming Parasitic, 92  
 Zymogenous *Saccharomyces*, New, 95



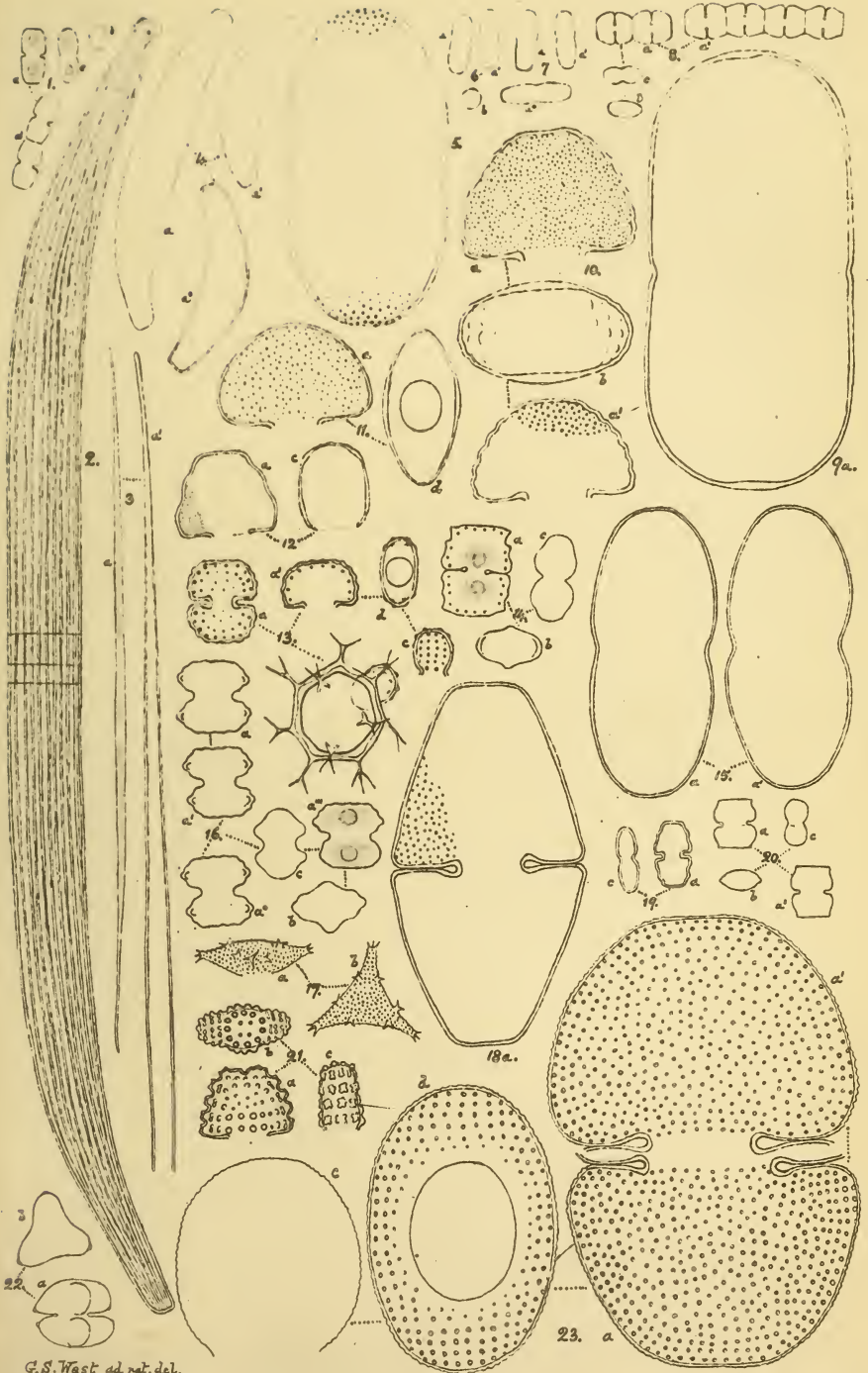

G. S. West ad nat. del.





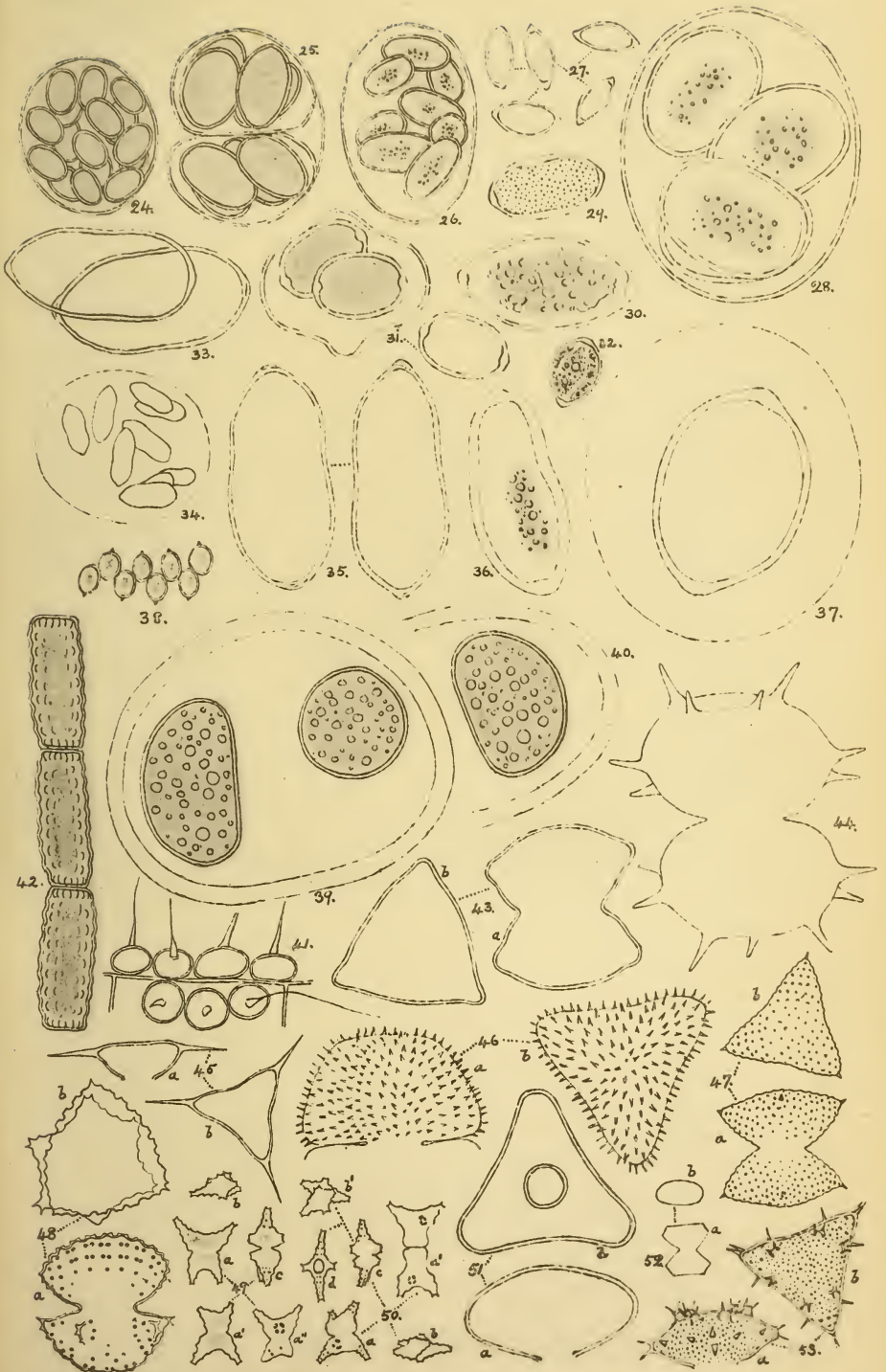

G. S. WEST, ad nat. del.



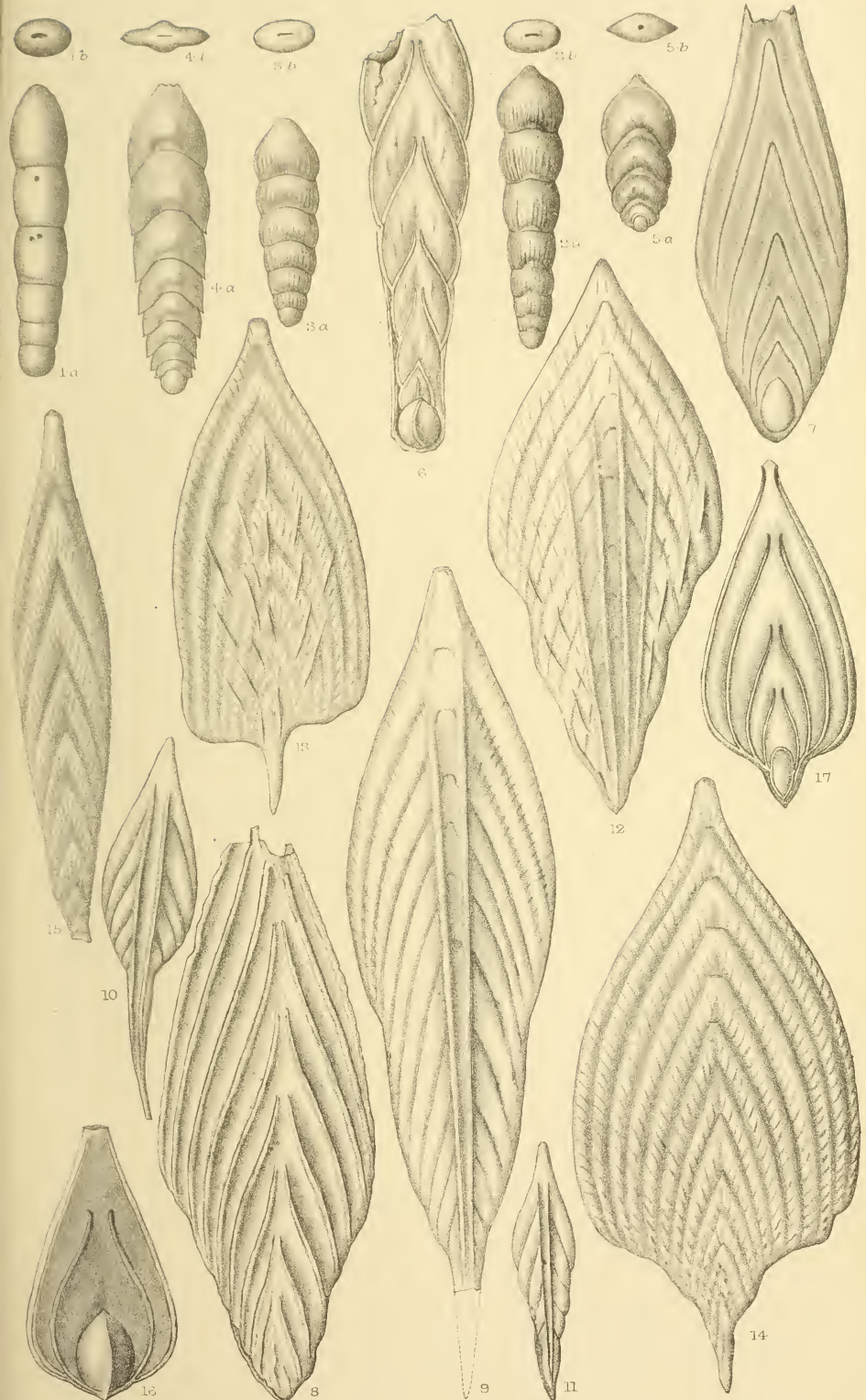







F. Chapman del.

Folkestone-Gault Foraminifera.

West, Newman lith



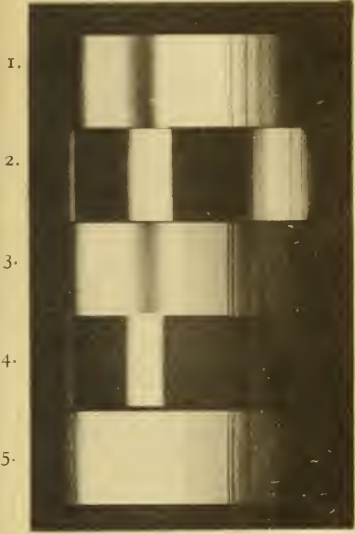

J. W. GIFFORD, PHOT.

A NEW MONOCHROMATIC LIGHT SCREEN.

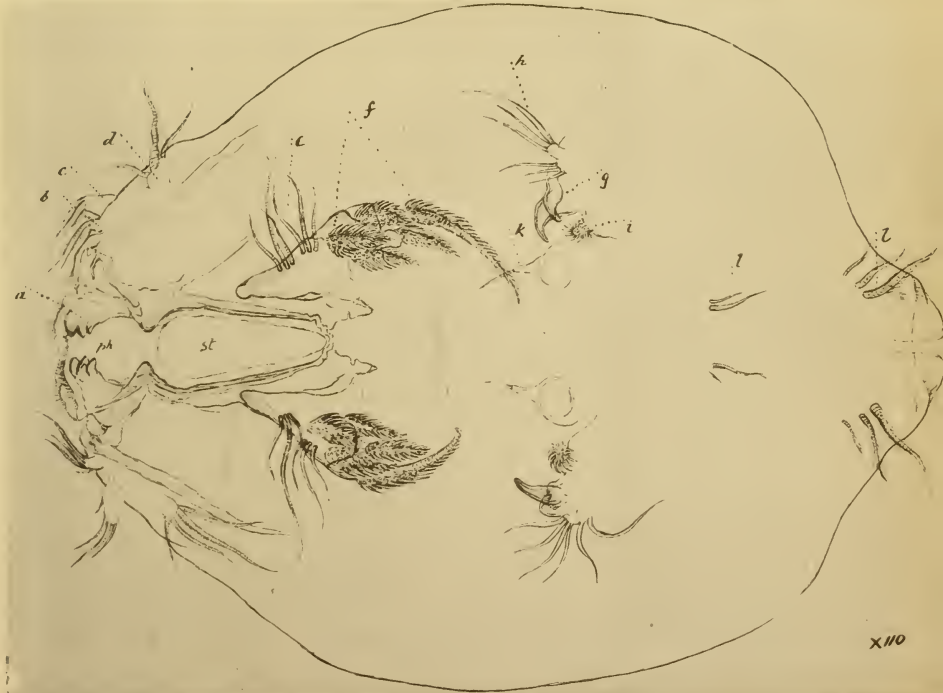

G. S. BRADY, del.

FUCITROGUS RHODYMENIÆ.





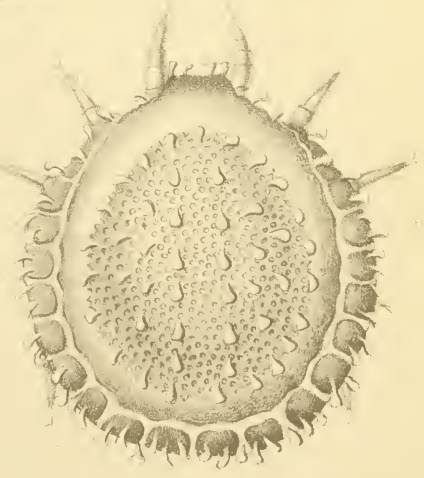
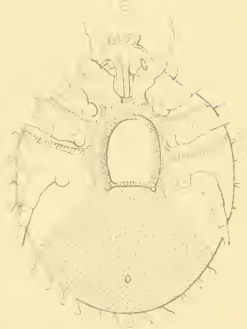
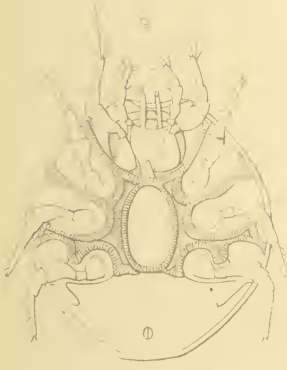
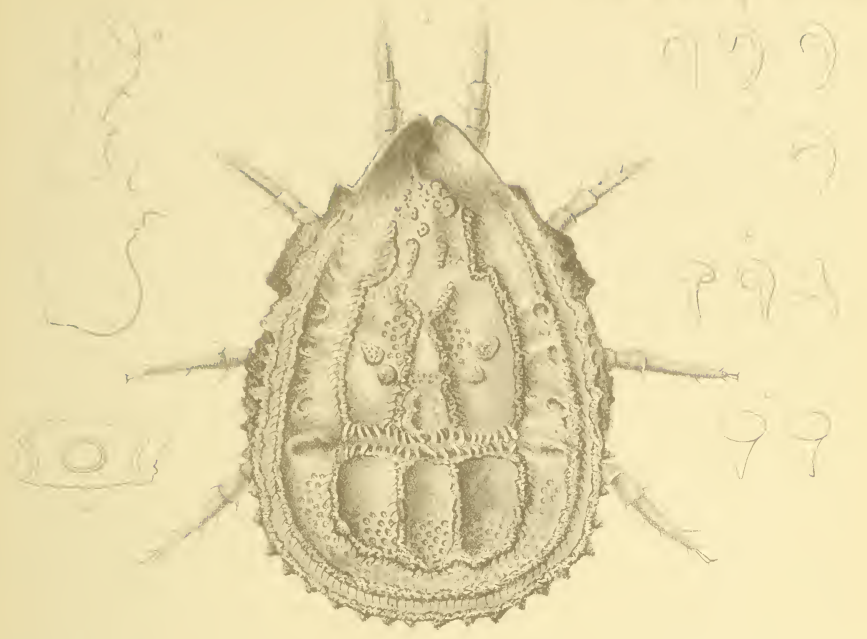



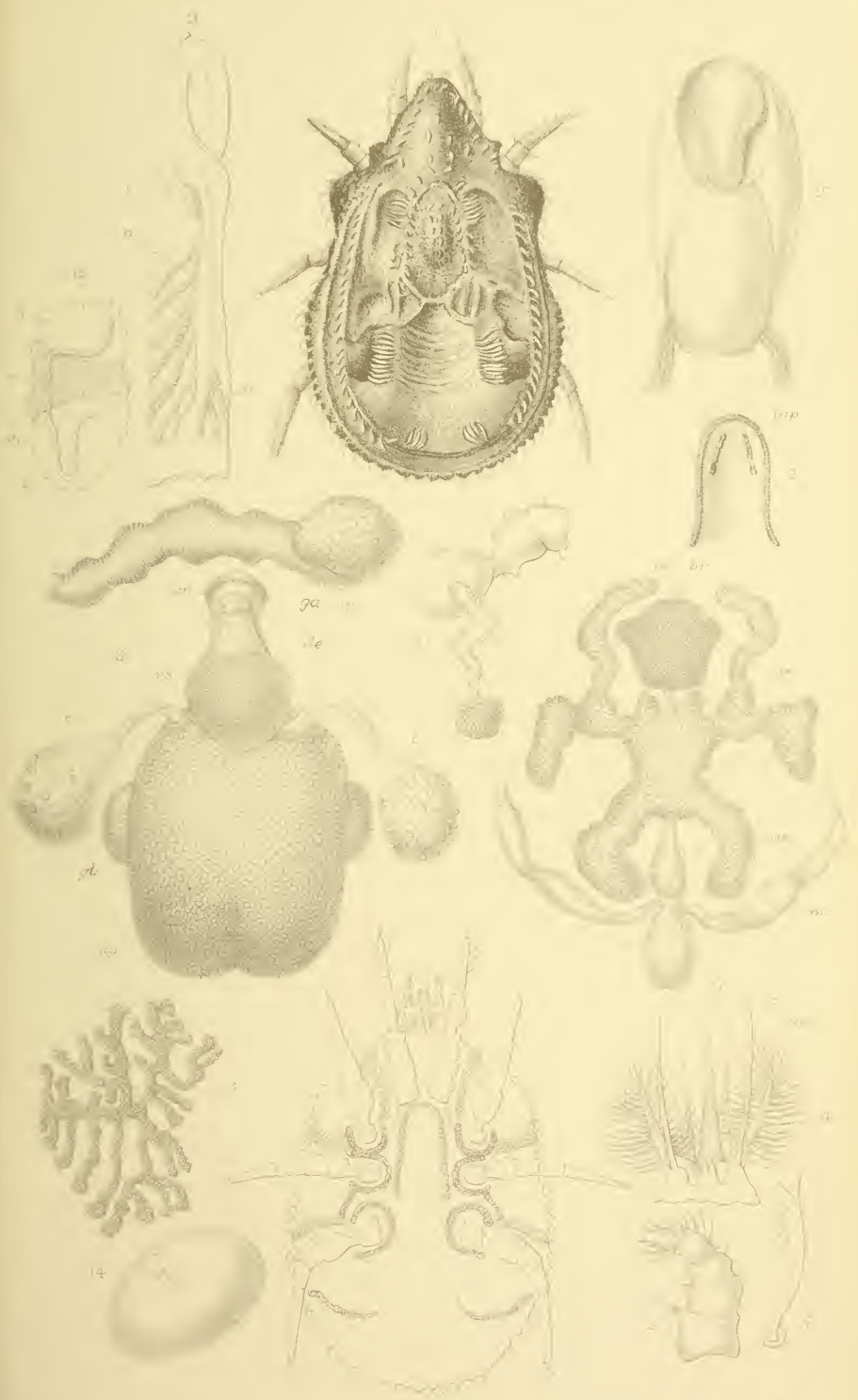

A. Michaelson del. sc.

West Nyassae. 1907

Glyphosis formicariae





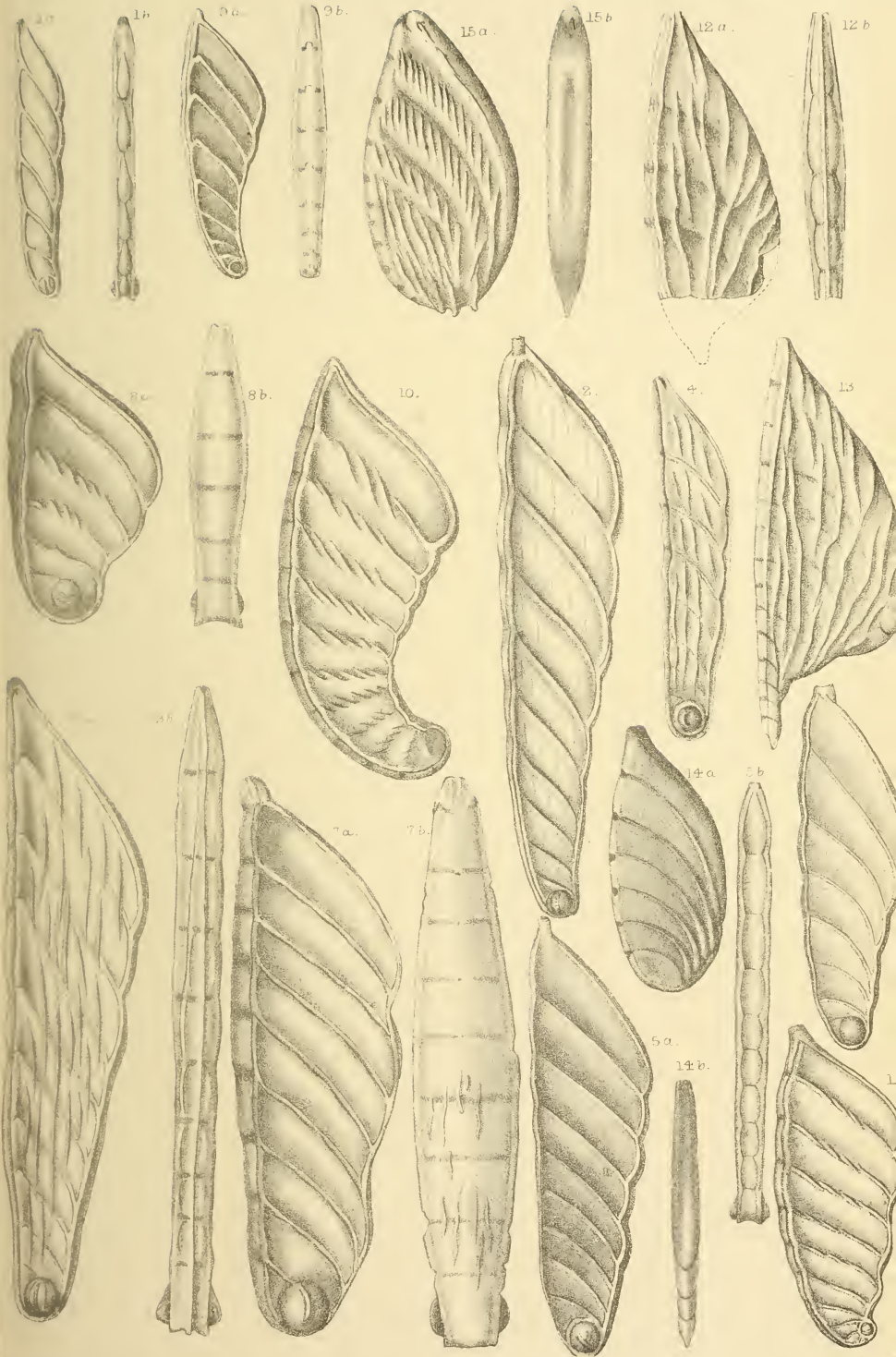

1. Chapman del. et. sculp.

Folkestone-Gault Foraminifera

West Newman





Massachusetts

West Newman

Folkestone-Gault Foraminifera







F Chapman delinat

West Newman lith

Folkestone-Cault Foraminifera

# CONTENTS.

## TRANSACTIONS OF THE SOCIETY—

	PAGE
I.—NEW BRITISH FRESHWATER ALGÆ. By William West, F.L.S., assisted by G. S. West. (Plates I. and II.) .. .. .	1
II.—THE PRESIDENT'S ADDRESS: THE PROGRESS AND PRESENT STATE OF OUR KNOWLEDGE OF THE ACARL. By A. D. Michael, F.L.S. .. .. .	18

## SUMMARY OF CURRENT RESEARCHES.

### ZOOLOGY.

#### A. VERTEBRATA:—Embryology, Histology, and General.

##### a. Embryology.

BORN, G., & W. ROUX— <i>Experimental Embryology</i> .. .. .	34
GORONOWITSCH, N.— <i>Ectodermic Origin of Skeletal Rudiments</i> .. .. .	35
MALL, F.— <i>Human Embryo of Second Week</i> .. .. .	35
ABY, F. S.— <i>Development of Hypophysis Cerebri in the Domestic Cat</i> .. .. .	35
HAYCRAFT, J. B.— <i>Development of Wolfian Body in Chick and Rabbit</i> .. .. .	36
KÜKENTHAL, W.— <i>Dentition of Pinnipedia</i> .. .. .	36
RÖSE, C.— <i>Dentition of Wombat</i> .. .. .	37
GORONOWITSCH, N.— <i>Ganglion Ridges in the Head of Birds</i> .. .. .	37
LECHE, W.— <i>Development of Teeth in Iguana</i> .. .. .	38
BEMMELEN, J. F. VAN— <i>Development of Gill-pouches and Aortic Arches in Chelonia</i> .. .. .	38
FICK, R.— <i>Maturation and Fertilization of Egg of Azolott</i> .. .. .	38
PLATT, J. B.— <i>Ontogenetic Differentiations of Ectoderm in Necturus</i> .. .. .	39
MORGAN, T. H.— <i>Experimental Studies on Eggs of Teleosteans</i> .. .. .	40
KOEHLER, R., & E. BATAILLON— <i>Growth of Blastoderm in Teleosteans</i> .. .. .	40
BATAILLON, E., & R. KOEHLER— <i>Karyokinetic Phenomena in Cells of Blastoderm of Teleosteans</i> .. .. .	41
KLAATSCH, H.— <i>Vertebral Column of Fishes</i> .. .. .	41
HOFFMANN, C. K.— <i>Origin of Vascular System in Selachii</i> .. .. .	42
HERFORD, K. V.— <i>Maturation of the Ovum of the Lamprey</i> .. .. .	43

##### b. Histology.

REINKE, F.— <i>Minute Structure of the Cell</i> .. .. .	43
ROUX, W.— <i>Interactions between Cell-substance and Nucleus</i> .. .. .	43
HEIDENHAIN, M.— <i>Nucleus and Protoplasm</i> .. .. .	44
DEMOOR, L.— <i>Structure of Reticulated Tissue</i> .. .. .	44
NUSBAUM, J.— <i>Behaviour of Pigment-granules during Karyokinesis</i> .. .. .	44

##### γ. General.

WENDT, G.— <i>Chemistry of Protoplasm</i> .. .. .	45
---	----

#### B. INVERTEBRATA.

MONTICELLI, F. S.— <i>Parasites of Holothurians of Naples</i> .. .. .	45
---	----

##### Mollusca.

##### a. Cephalopoda.

APPELLÖF, A.— <i>Cephalopoda of North Sea</i> .. .. .	45
PHISALIX, C.— <i>Inhibition in Cephalopoda</i> .. .. .	45
APPELLÖF, A.— <i>Bilateral Hectocotylization in Eledone cirrhosa</i> .. .. .	46

##### γ. Gastropoda.

HALLER, B.— <i>Neotænioglossæ</i> .. .. .	46
COLLINGE, W. E.— <i>Absence of Male Reproductive Organs in Two Hermaphrodite Molluscs</i> .. .. .	46
BERGH, R.— <i>Dorididæ</i> .. .. .	46
KÖHLER, A.— <i>Siphonaria</i> .. .. .	47
PLATE, L. H.— <i>The Oncidiidæ</i> .. .. .	47
METCALF, M. M.— <i>Embryology of Chiton</i> .. .. .	49
CARUS, J. V.— <i>Index to the Zoologischer Anzeiger</i> .. .. .	49

## 5. Lamellibranchiata.

PAGE

KNOLL, PH.— <i>Muscle-Fibres of Mollusca</i> .. .. .	49
--	----

## Molluscoida.

## a. Tunicata.

SEELIGER, O.— <i>Origin of Peribranchial Cavity in Ascidian Embryos</i> .. .. .	50
"   " <i>Formation of Mantle</i> .. .. .	50
HERDMAN, W. A.— <i>British Tunicata</i> .. .. .	50
HEIDEN, H.— <i>Ascidians of Minorca</i> .. .. .	51
BORGERT, A.— <i>New Doliolum</i> .. .. .	51

## Arthropoda.

PERRIER, E.— <i>Arthropoda</i> .. .. .	51
HANSEN, H. J.— <i>Morphology of Crustacean and Insect Appendages</i> .. .. .	52

## a. Insecta.

HAASE, C.— <i>Mimicry</i> .. .. .	52
PATRIZI, M. L.— <i>Muscular Action in Bombyx</i> .. .. .	52
AUERBACH, L.— <i>Spermatozoa of Dytiscus</i> .. .. .	52
VERHOEFF, C.— <i>Copulatory Organs of Male Hymenoptera</i> .. .. .	53
BORDAS— <i>Male Genital Apparatus of Hymenoptera</i> .. .. .	53
INGENITZKY, J.— <i>Copulatory Organs of Libellulidæ</i> .. .. .	53
LUCAS, R.— <i>Mouth-parts of Trichoptera</i> .. .. .	54
BOAS, J. E. V.— <i>Stigmata of Larva of Melolontha</i> .. .. .	54
CAMERANO, L.— <i>Respiratory Movements of Coleoptera</i> .. .. .	55
SCUDDER, S. H.— <i>Orthoptera of Galapagos</i> .. .. .	55

## 5. Arachnida.

SCHIMKEWITSCH, W.— <i>Endosternite of Arachnida</i> .. .. .	55
BERNARD, H. M.— <i>Stigmata of Arachnida</i> .. .. .	55
POCOCK, R. I.— <i>Instincts of Common English Spiders</i> .. .. .	55
BERNARD, H. M.— <i>Chernetidæ</i> .. .. .	56
WAGNER, W.— <i>Activity of Heart of Spiders</i> .. .. .	56
KARPELLES, L.— <i>Anatomy of Bdella arenaria</i> .. .. .	57

## e. Crustacea.

PARKER, T. JEFFERY, & J. G. RICH— <i>Myology of Palinurus Edwardsi</i> .. .. .	57
BERGH, R. S.— <i>Germinal Area of Mysis</i> .. .. .	57
MRAZEK, AL.— <i>Antennæ of Cyclopidæ</i> .. .. .	58
SCHMEIL, O.— <i>The Genus Cyclops</i> .. .. .	58
CLAUS, C.— <i>The Pontellidæ</i> .. .. .	58
" <i>New Observations on Cyclops</i> .. .. .	59
" <i>Skeleton of Copepoda</i> .. .. .	59
BRAUER, A.— <i>Ovum of Branchipus</i> .. .. .	59
BRAEM, F.— <i>The Genus Apus</i> .. .. .	60

## Vermes.

## a. Annelida.

MALACQUIN, A.— <i>Researches on Syllidæ</i> .. .. .	60
MESNIL, F.— <i>Polydora</i> .. .. .	62
FRIEND, H.— <i>New Irish Earthworms</i> .. .. .	62
CROCKEWEIT, J. M.— <i>Jaws of Hirudinea</i> .. .. .	62
LEUCKART, R.— <i>Infundibular Apparatus of Hirudinea</i> .. .. .	62
WHITMAN, C. O.— <i>Eye of Clepsine</i> .. .. .	62

## B. Nemathelminthes.

BRAUER, A.— <i>Spermatogenesis in Ascaris megalcephala</i> .. .. .	63
HAMANN, O.— <i>Schneider's Pore and Esophageal Glands in Nematodes</i> .. .. .	63
REIBISCH, J.— <i>Trichosomum strumosum sp.n.</i> .. .. .	64
HAMANN, O.— <i>History of Filaria uncinata</i> .. .. .	64
JANET, C.— <i>Nematodes of Pharyngeal Glands of Ants</i> .. .. .	64
JANSON— <i>Filaria immitis in a Japanese Wolf</i> .. .. .	65
CERFONTAINE, P.— <i>Trichinosis</i> .. .. .	65
KAISER, J. E.— <i>Acanthocephala</i> .. .. .	65



γ. Platyhelminthes.		PAGE
REPIACHOFF, W.— <i>Spermatogenesis of Turbellaria</i> .. .. .		65
NOACK, E. J.— <i>Distomum clavigerum</i> .. .. .		65
HASWELL, W. A.— <i>Monograph of Temnocephalæ</i> .. .. .		65
"    " <i>Apparently New Type of Platyhelminth</i> .. .. .		66
δ. Incertæ Sedis.		
LAUTERBORN, R.— <i>Rotifers of the Rhine</i> .. .. .		67
IMHOFF, O. E.— <i>Alpine Rotifers</i> .. .. .		67
HOOD, J., & D. BRYCE— <i>New Rotifers</i> .. .. .		67
Echinoderma.		
GRIEG, J. A.— <i>Ophiuroids of North Sea</i> .. .. .		67
MORTENSEN, T.— <i>Ophiopus arcticus</i> .. .. .		67
BATHER, F. A.— <i>Silurian Crinoids</i> .. .. .		68
Cœlentera.		
GOETTE, A.— <i>Development of Pelagia</i> .. .. .		69
LANKESTER, E. RAY— <i>Reappearance of Limnocoedium Sowerbii</i> .. .. .		69
Porifera.		
WELTNER, W.— <i>Studies on Spongillidæ</i> .. .. .		69
SCHULZE, F. E.— <i>Revision of Hyalonematidæ</i> .. .. .		70
Protozoa.		
VERWORN, M.— <i>Physiological Significance of Cell-nucleus</i> .. .. .		70
SASSAKI, C.— <i>A New Heliozoon</i> .. .. .		70
RÖMER, F.— <i>A New Vorticella</i> .. .. .		71
SHEWIAKOFF, W.— <i>Parasites of Cyclopidæ</i> .. .. .		71
POUCHET, G.— <i>Polymorphism of Peridinium acuminatum</i> .. .. .		71
MINGAZZINI— <i>Classification of Sporozoa</i> .. .. .		71
FLEXNER, S.— <i>Amœbæ in Abscess of Jaw</i> .. .. .		72
THÉLOHAN, P.— <i>Muscle Degeneration in Barbel from presence of Myxosporidia</i> .. .. .		72
BETRAM, A.— <i>Sarcosporidia of the Gecko, Sheep, and Swine</i> .. .. .		72
PETERSEN, W.— <i>Psorosperms of Darier's Disease</i> .. .. .		73

## BOTANY.

### A. GENERAL, including the Anatomy and Physiology of the Phanerogamia.

#### a. Anatomy.

##### (1) Cell-structure and Protoplasm.

FARMER, J. B.— <i>Nuclear Division in the Pollen-mother-cells of Lilium Martagon</i> ..	74
BIELIAJEW, W.— <i>Karyokinesis in Pollen-mother-cells of Larix</i> .. .. .	74
RACIBORSKI, M.— <i>Nucleus of Germinating Seeds</i> .. .. .	74
WAHRlich, W.— <i>Anatomy of the Cell in Fungi and Filiform Algæ</i> .. .. .	74
MANGIN, L.— <i>Pectic Substances in Tissues</i> .. .. .	75
ZIMMERMANN, A.— <i>Silicified Thickening of Cell-wall</i> .. .. .	75

##### (2) Other Cell-contents (including Secretions).

SPATZIER, W.— <i>Myrosin in Plants</i> .. .. .	76
BELZUNG, E.— <i>Spherocrystals of Euphorbia</i> .. .. .	76
ZIMMERMANN, A.— <i>Elaioplasts</i> .. .. .	76
WINTERSTEIN, E.— <i>Vegetable Amyloid</i> .. .. .	76
RACIBORSKI, M.— <i>Contents of the Trichomes of Myriophyllum</i> .. .. .	76
GAIN, E.— <i>Colouring Matters of Underground Organs</i> .. .. .	77
ZIMMERMANN, A.— <i>Excretions of Calcium Phosphate</i> .. .. .	77

##### (3) Structure of Tissues.

JOST, L.— <i>Relationship between Leaf-development and the Formation of Vessels</i> ..	77
WIELER, A.— <i>Stoppages of Vessels</i> .. .. .	77
GROOM, P.— <i>Aleurone-layer in the Seed of Grasses</i> .. .. .	78
MANGIN, L.— <i>Mucilage-layer in Flax-seeds</i> .. .. .	78
MATSUDA, S.— <i>Anatomy of Magnoliacæ</i> .. .. .	78
QUEVA, C.— <i>Anatomy of the Stem of Dioscoreacæ</i> .. .. .	78



	PAGE
RITTERSHAUSEN, P.— <i>Anatomy of the Acalyphææ</i> .. .. .	78
ENGLER, A.— <i>Icacinacææ</i> .. .. .	79

## (4) Structure of Organs.

REICHE, K.— <i>Anatomical Characters of Cæspitose Plants</i> .. .. .	79
GOEBEL, K.— <i>Insectivorous Plants</i> .. .. .	79
TOGNINI, F.— <i>Female Flower and Fruit of the Chestnut</i> .. .. .	79
MAYOUX, MDLLE.— <i>Staminal Appendages of Aristolochia</i> .. .. .	80
CELAKOVSKY, L.— <i>Stigmatic Lobes of Iris</i> .. .. .	80
” ” <i>Cupule of Quercus</i> .. .. .	80
KAYSER, G.— <i>Development of the Seed</i> .. .. .	80
GUIGNARD, L.— <i>Development of the Seed and of its Integument</i> .. .. .	81
SCHIPS, K., & OTHERS— <i>Cuticle of the Seeds of Papilionacææ</i> .. .. .	81
STAHL, E.— <i>Protection of Leaves against Excessive Rainfall</i> .. .. .	82
BALDACCI, A.— <i>Branching of Borraginacææ and Apocynacææ</i> .. .. .	82
PEIRCE, G. J.— <i>Haustoria of Phanerogamic Parasites</i> .. .. .	82
QUEVA, C.— <i>Bulbils of Dioscoreacææ</i> .. .. .	83
NYPELS— <i>Tubers of Apios tuberosa and Helianthus tuberosus</i> .. .. .	83
ANDOUARD, A.— <i>Development of Arachis</i> .. .. .	83

## β. Physiology.

## (1) Reproduction and Embryology.

WILLIS, J. C.— <i>Fertilization of Claytonia, Phacelia, and Monarda</i> .. .. .	84
ACQUA, C.— <i>Germination of the Pollen of Vinca major</i> .. .. .	84
SCHILSBERSKY, C.— <i>Dimorphism of the Flowers of Convolvulus arvensis</i> .. .. .	84

## (2) Nutrition and Growth (including Germination, and Movements of Fluids).

LANDEL, G.— <i>Influence of the Solar Rays on Growth</i> .. .. .	84
GAIN, E.— <i>Influence of External Conditions on Growth</i> .. .. .	85
JACCARD, P.— <i>Influence of the Pressure of Gases on Growth</i> .. .. .	85
DEHÉRAIN, P. P.— <i>Unequal Resistance of Plants to Drought</i> .. .. .	85
WRIGHT, J. S.— <i>Cell-union in Herbaceous Grafting</i> .. .. .	85
LETELLIER, A.— <i>Growth of the Root</i> .. .. .	85
FRANK, B., & OTHERS— <i>Assimilation of Free Nitrogen by Plants</i> .. .. .	86
BOEHM, J.— <i>Capillarity and Ascent of Sap</i> .. .. .	87
JÖNSSON, B.— <i>Internal Bleeding of Plants</i> .. .. .	87

## (4) Chemical Changes (including Respiration and Fermentation).

AMM, A.— <i>Intramolecular Respiration</i> .. .. .	87
--	----

## γ. General.

HENSLOW, G.— <i>Origin of Endogens</i> .. .. .	87
MURRAY, G., & A. H. CHURCH— <i>Parasites on Algæ</i> .. .. .	87

## B. CRYPTOGAMIA.

## Cryptogamia Vascularia.

GIBSON, R. J. HARVEY— <i>Siliceous Deposit in Selaginella</i> .. .. .	88
BOWER, F. O.— <i>Sporophyte of Equisetines and Lycopodinesæ</i> .. .. .	88
CAMPBELL, D. H.— <i>Development of Marattia</i> .. .. .	88
BOWER, F. O.— <i>Structure of Lepidostrobus</i> .. .. .	88

## Algæ.

AGARDH, J. G.— <i>New Genera of Algæ</i> .. .. .	89
SCHMIDLE, W.— <i>Algæ of the Black Forest and Rhine Country</i> .. .. .	89
STOCKMAYER, S.— <i>Pellicle of Algæ</i> .. .. .	89
ISTVÁNFÉI, J.— <i>“Meteoric Paper”</i> .. .. .	89
HEYDRICH, F.— <i>Pleurostichidium, a New Genus of Floridææ</i> .. .. .	89
SETCHELL, W. A.— <i>Laminariacææ</i> .. .. .	90
LÜTKEMÜLLER, J.— <i>Chlorophores of Spirotænia obscura</i> .. .. .	90
HUBER, J.— <i>Epiphytic and Endophytic Chætophoracææ</i> .. .. .	90
JOHNSON, L. N.— <i>Zoospores of Draparnaldia</i> .. .. .	91
RICHTER, P.— <i>Chætomorpha Henningsii</i> .. .. .	91
WHITTING, F. C., & E. DE WILDEMAN— <i>Chlorocystis</i> .. .. .	92
FRANZÉ, E.— <i>Chlamydomonadinææ</i> .. .. .	92

## Fungi.

PAGE

ZUKAL, H.— <i>Saprophytic Fungus becoming Parasitic</i> .. .. .	92
"   " <i>Fungus growing in a saturated solution of salt</i> .. .. .	92
"   " <i>New Genera of Fungi</i> .. .. .	92
PRUNET, A., & OTHERS— <i>Parasitic Fungi</i> .. .. .	93
ATKINSON, G. F.— <i>Symbiotic Fungus of Ophioglossaceæ</i> .. .. .	94
BOURQUELOT & GRAZIANI— <i>Physiology of Penicillium Duclauxi</i> .. .. .	94
JANCZEWSKI, DE, & PIROTTA, R.— <i>Polymorphism of Cladosporium herbarum</i> .. .. .	94
NEUBNER, E.— <i>Calyciæ</i> .. .. .	94
CAVARA, F.— <i>New Zymogenous Saccharomyces</i> .. .. .	95
DANGEARD, P. A.— <i>Histological Structure and Development of Yeasts</i> .. .. .	95
THAXTER, R.— <i>Laboulbeniaceæ</i> .. .. .	95
SABOURAUD, R.— <i>Ringworm in Man</i> .. .. .	97
JONES, A. C.— <i>Fungus found in Phthirical Cavities and Sputa</i> .. .. .	97

## Protophyta.

## B. Schizomycetes.

FREUDENREICH, E. v.— <i>Resistance of Bacteria to Pressure combined with a High Temperature</i> .. .. .	97
WINOGRADSKY, S.— <i>Assimilation of Atmospheric Nitrogen by Microbes</i> .. .. .	97
MARCHAL, E.— <i>Bacillus mycoïdes and Nitrification</i> .. .. .	98
DENYS, J., & A. KAISIN— <i>Bactericidal Power of the Blood</i> .. .. .	98
ISSAEFF, B.— <i>Acquired Immunity to Pneumococcus</i> .. .. .	99
MALVOZ, E.— <i>Presence of Bacterium coli commune and Bacillus typhosus in Drinking-Water</i> .. .. .	99
LANDMANN— <i>Streptococcus longus in Drinking-Water</i> .. .. .	100
STRAZZA— <i>Capsule Bacillus of Ozæna</i> .. .. .	100
PFEIFFER, R.— <i>Pfeiffer's Influenza Bacillus</i> .. .. .	100
SANARELLI, J.— <i>Water Vibrios and the Ætiology of Cholera</i> .. .. .	101
BIBLIOGRAPHY .. .. .	102

## MICROSCOPY.

## a. Instruments, Accessories, &amp;c.

## (1) Stands.

LEITZ's <i>Microscope</i> (Fig. 1) .. .. .	103
NELSON, E. M.— <i>Leitz's New Microscope Stand</i> .. .. .	103
WIESNER, J.— <i>Microscope for Measurement of Growth of Plants</i> .. .. .	103
LEITZ's <i>Mechanical Stage</i> (Fig. 2) .. .. .	105
NELSON, E. M.— <i>A Farmer's Microscope</i> (Figs. 3 and 4) .. .. .	106

## (3) Illuminating and other Apparatus.

GUGLIELMO, G.— <i>New Exact and Easily Constructed Spherometer</i> (Fig. 5) .. .. .	107
NELSON, E. M.— <i>Chimney for a Microscope Lamp</i> (Fig. 6) .. .. .	108
LEITZ's <i>Microscope Screw Adjustment</i> (Fig. 7) .. .. .	109

## (4) Photomicrography.

LEITZ's <i>Photomicrographic Apparatus</i> (Fig. 8) .. .. .	109
MARKTANNER-TURNERETSCHER, G.— <i>On Instantaneous Photomicrography</i> (Fig. 9) .. .. .	110
ZOFH, O.— <i>On the Cooling of Projection Preparations</i> (Fig. 10) .. .. .	112
MONPILLARD— <i>Orthochromatism applied to Photomicrography</i> .. .. .	113

## (5) Microscopical Optics and Manipulation.

WEBER, L.— <i>Chromatic Aberration of Lenses</i> (Fig. 11) .. .. .	116
--	-----

## (6) Miscellaneous.

THE LATE Dr. Kützing .. .. .	118
PROF. A. Milnes Marshall .. .. .	118
PROF. P. J. Van Beneden .. .. .	118
NELSON, E. M.— <i>Measurement of Light and Colour Sensations</i> .. .. .	119
PATENTS for Inventions .. .. .	120

## B. Technique.

LEE, A. BOLLES— <i>Microtometist's Vade-Mecum</i> .. .. .	120
---	-----



## (1) Collecting Objects, including Culture Processes.

	PAGE
CORI, C. J.— <i>Stage-Aquarium</i> (Fig. 12) .. .. .	121
KOCH, A.— <i>Apparatus for Regulating the Temperature of Hatching-Ovens, &amp;c.</i> (Fig. 13) .. .. .	123
OGATA, M.— <i>Cultivating Protozoa</i> .. .. .	123
BENEKE— <i>Puncture Cultivations</i> .. .. .	124
SCHWEINITZ, E. A. DE— <i>Culture Media for Biochemic Investigations</i> .. .. .	124
MÜLLER, K.— <i>Inoculation Apparatus for Rats and Mice</i> .. .. .	125
SCHEPILEWSKY, E. A.— <i>Hot-water Thermostat with Automatic Regulator</i> (Fig. 14)	125
WICHMANN, H.— <i>Cultivating Ascospores</i> .. .. .	127
SANARELLI, J.— <i>Cultivating Vibrios</i> .. .. .	127
NOVY, F. G.— <i>Cultivation Media for Anaerobic Bacteria</i> .. .. .	127
SCHLOSSER, H.— <i>Urine-Agar for Cultivating Diphtheria Bacillus</i> .. .. .	128
VOGES, O.— <i>Growth of Cholera Bacilli on Potato</i> .. .. .	128
ABEL— <i>Isolating Bacillus of Diphtheria from Toys</i> .. .. .	128

## (2) Preparing Objects.

BERKLEY, H. J.— <i>Investigating Histology of Vertebrate Liver</i> .. .. .	129
METCALF, M. M.— <i>Embryology of Chiton</i> .. .. .	129
DEMOOR, L.— <i>Investigation of Reticulated Tissue</i> .. .. .	130
SCHAFFER, J.— <i>Method for Histological Examination of Osseous Tissue</i> .. .. .	130
GIBBES, HENEAGE— <i>Demonstration of Psorosperms</i> .. .. .	130
HAUSER, G.— <i>Conservation of Bacterial Cultivations by means of Formalin</i> .. .. .	130

## (3) Cutting, including Imbedding and Microtomes.

LEITZ <i>Microtome</i> (Fig. 15) .. .. .	131
BORN, G.— <i>A New Section-stretcher</i> (Fig. 16) .. .. .	132

## (4) Staining and Injecting.

FIUCCA'S <i>Method for Spore-Staining</i> .. .. .	133
LIGNIER, O.— <i>Employment of Vesuvium for Fossil Plants</i> .. .. .	133
SÉGALL, B.— <i>Demonstrating Intercalary Rings of Nerve-fibres</i> .. .. .	133
RAMON Y CAJAL, S.— <i>Cox's Method for Demonstrating the Nerve-fibres of Central Nervous System</i> .. .. .	134
MARPMANN— <i>Examining Street Dust for Tubercle Bacilli</i> .. .. .	134

## (5) Mounting, including Slides, Preservative Fluids, &amp;c.

HERMANN, F.— <i>Formalin as a Hardening and Preservative Medium</i> .. .. .	135
ZETNOW— <i>Cleaning New Cover-glasses</i> .. .. .	135
ZIMMERMANN, A.— <i>Dr. M. Kuster's Hollow Spheres for Microscopic Objects</i> .. .. .	135

## (6) Miscellaneous.

RIEDER'S <i>Atlas of the Clinical Microscopy of the Blood</i> .. .. .	136
LUSTIG, A.— <i>Diagnosis of Water Bacteria</i> .. .. .	136
KITT'S <i>Bacteriology and Pathological Microscopy</i> .. .. .	137
GEDOELST'S <i>Bacteriology for Veterinary Surgeons</i> .. .. .	137
GÜNTHER'S <i>Bacteriology</i> .. .. .	137
EBERTH, O. J.— <i>Friedländer's Microscopical Technique</i> .. .. .	137
VON KAHLDEN'S <i>Microscopical Technique</i> .. .. .	137

## PROCEEDINGS OF THE SOCIETY:—

Meeting, 20th December, 1893 .. .. .	138
Annual Meeting, 17th January, 1894 .. .. .	148

Authors of Papers printed in the Transactions are entitled to 20 copies of their communications *gratis*. Extra copies can be had at the price of 10s. 6d. per half-sheet of 8 pages, or less, including cover, for a minimum number of 50 copies, and 6s. per 100 plates, if plain. Prepayment by P.O.O. is requested.

8

# R. & J. BECK'S LATEST MICROSCOPE.

No. 31. LARGE CONTINENTAL MODEL WITH PERFECT FINE ADJUSTMENT, AND RACK AND PINION (CENTERING) SUBSTAGE.

SPECIALLY ADAPTED FOR BACTERIOLOGY & HIGH-POWER WORK.

MICROTOMES.

—  
CABINETS.

—  
LAMPS.

—  
NEW  
1/12 IN.

OIL-  
IMMERSION  
OBJECT-  
GLASS.

THE INSTRUMENT  
AS FIGURED, WITH  
TWO EYE-PIECES,  
2/3 IN. AND 1/6 IN.  
OBJECT-GLASSES,  
ABBE CONDENSER  
WITH IRIS  
DIAPHRAGM  
PACKED IN  
POLISHED  
MAHOGANY  
CASE,  
£11 10 0

—  
FULLY  
ILLUSTRATED  
CATALOGUE  
FREE ON  
APPLICATION.

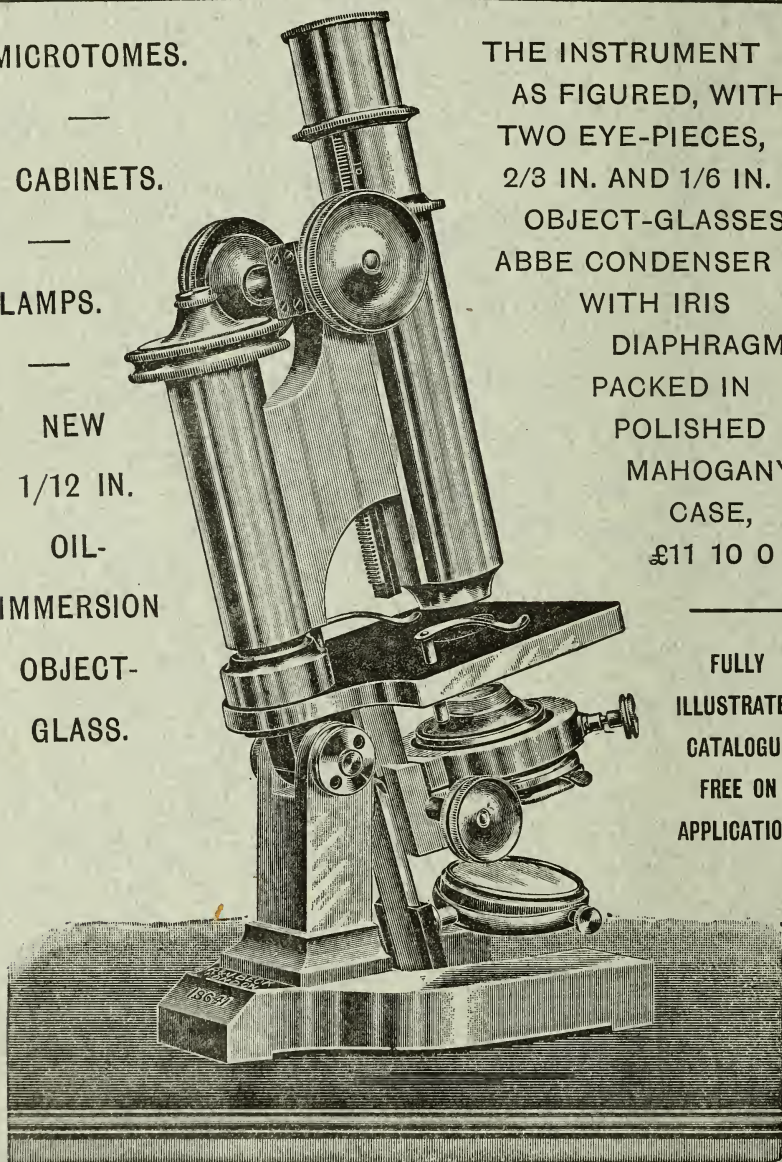

**R. & J. BECK, 68 CORNHILL, LONDON, E.C.**

FACTORY: LISTER WORKS KENTISH TOWN, N.W.



The Journal is issued on the third Wednesday in  
February, April, June, August, October, and December.

1894. Part 2.

APRIL.

To Non-Fellows,  
Price 6s.

6994

# JOURNAL

OF THE

# ROYAL

# MICROSCOPICAL SOCIETY;

CONTAINING ITS TRANSACTIONS AND PROCEEDINGS,  
AND A SUMMARY OF CURRENT RESEARCHES RELATING TO  
ZOOLOGY AND BOTANY  
(principally Invertebrata and Cryptogamia),  
MICROSCOPY, &c.

*Edited by*

**F. JEFFREY BELL, M.A.,**

*One of the Secretaries of the Society  
and Professor of Comparative Anatomy and Zoology in King's College;*

WITH THE ASSISTANCE OF THE PUBLICATION COMMITTEE AND

**A. W. BENNETT, M.A., B.Sc., F.L.S.,**  
*Lecturer on Botany at St. Thomas's Hospital,*  
**R. G. HEBB, M.A., M.D. (Cantab.),** AND

**J. ARTHUR THOMSON, M.A.,**  
*Lecturer on Zoology in the School of Medicine,  
Edinburgh,*

FELLOWS OF THE SOCIETY.



LONDON:

TO BE OBTAINED AT THE SOCIETY'S ROOMS,  
20 HANOVER SQUARE, W.;

OF MESSRS. WILLIAMS & NORGATE; AND OF MESSRS. DULAU & CO.

# CONTENTS.

## TRANSACTIONS OF THE SOCIETY—

	PAGE
III.—THE FORAMINIFERA OF THE GAULT OF FOLKESTONE.—V. By Frederick Chapman, F.R.M.S. (Plates III. and IV.) ..	153
IV.—AN INEXPENSIVE SCREEN FOR MONOCHROMATIC LIGHT. By J. William Gifford, F.R.M.S. (Plate V.) .. .. .	164
V.—ON FUCITROGUS RHODYMENÆ, A GALL-PRODUCING COPEPOD. By G. S. Brady, M.D., LL.D., F.R.S. (Plate V.) .. ..	168

## SUMMARY OF CURRENT RESEARCHES.

### ZOOLOGY.

#### A. VERTEBRATA:—Embryology, Histology, and General.

##### a. Embryology.

HERTWIG, O.— <i>Experimental Embryology</i> .. .. .	171
BOS, RITZEMA— <i>Breeding in and in</i> .. .. .	172
HAAKE, W.— <i>Origin of Mammals</i> .. .. .	172
LECHE, W.— <i>Dentition of Mammals</i> .. .. .	173
SOBOTA, J.— <i>Fertilization in the Mouse</i> .. .. .	174
REICHEL, P.— <i>Development of Bladder and Urethra</i> .. .. .	174
GAUPP, E.— <i>Development of the Hypophysis</i> .. .. .	174
HOFFMANN, C. K.— <i>Origin of the Blood</i> .. .. .	175
POLLARD, H. B.— <i>Development of Head of Gobius Capito</i> .. .. .	175
MITROPHANOW, P.— <i>Embryogeny of Selachii</i> .. .. .	175
LOCY, W. A.— <i>Derivation of the Pineal Eye</i> .. .. .	176
HASSE, C.— <i>Development of the Vertebral Column</i> .. .. .	176
MINOT, C. S.— <i>Concerning the Gonotome</i> .. .. .	176
REH, L.— <i>Inheritance of Acquired Characters</i> .. .. .	176

##### β. Histology.

RATH, O. VOM— <i>Spermatogenesis in Salamandra maculosa</i> .. .. .	177
HÄCKER, V.— <i>Import of the Chief Nucleolus</i> .. .. .	178
HARDY, W. B., & LIM BOON KENG— <i>Changes induced by Urari in the Wandering Cells of the Frog</i> .. .. .	178

##### γ. General.

PICTET, R.— <i>Influence of Low Temperature</i> .. .. .	178
WERNER, F.— <i>Phenomena of Convergence</i> .. .. .	179

#### Mollusca.

##### γ. Gastropoda.

BERGH, R.— <i>Doridiidæ</i> .. .. .	179
"    " <i>The Genus Gastropteron</i> .. .. .	180
IHERING, H. VON— <i>Morphology of Sacoglossa</i> .. .. .	180
PELSENEER, P.— <i>Excretory and Reproductive Apparatus of Elysia</i> .. .. .	180
BOUTAN, L.— <i>Nervous System of Nerita and Navicella</i> .. .. .	181
PELSENEER, P.— <i>Shell Cavity of Philinidæ</i> .. .. .	182
GIROD, P.— <i>Kidney of Snail</i> .. .. .	182
BERGH, R.— <i>New Polycerad</i> .. .. .	182
STERKI, V.— <i>Growth Changes of Radula in Land Mollusca</i> .. .. .	182
LOCARD— <i>Mollusca of Water Mains of Paris</i> .. .. .	182
COCKERELL, T. D. A., & W. E. COLLINGS— <i>Check-List of Slugs</i> .. .. .	183

#### Molluscoida.

##### a. Tunicata.

METCALF, M. M.— <i>Eyes and Subneural Gland of Salpa</i> .. .. .	183
APSTEIN, C.— <i>Salpæ of Berlin Museum</i> .. .. .	183
TRAUSTEDT, M., & W. WELTNER— <i>Tunicata collected by Dr. Sander</i> .. .. .	183

##### β. Bryozoa.

PROUHO, H., & E. EHLERS— <i>Contributions to our Knowledge of Polyzoa</i> .. .. .	183
DUERDEN, J. E.— <i>New and Rare Irish Polyzoa</i> .. .. .	185



## Arthropoda.

## a. Insecta.

PAGE

CHILD, C. M.—Antennary Sensory Organs of Insects .. .. .	185
URECH, F.—Pigmentation in Scales of Lepidoptera and Coleoptera .. .. .	186
THOMAS, M. B.—Androconia of Lepidoptera .. .. .	186
JOHANSEN, H.—Development of Compound Eye of <i>Vanessa</i> .. .. .	186
NOGAKUSHI, K. TOYAMA—Spermatogenesis of <i>Bombyx Mori</i> .. .. .	187
PACKARD, A. S.—Life-history of Bombycine Moths .. .. .	187
POULTON, E. B.—Colours of Lepidopterous Larvæ .. .. .	188
” ” Sexes of Larvæ of <i>Smerinthus populi</i> .. .. .	188
GRIFFITHS, A. B.—Reproductive Organs of <i>Noctua pronuba</i> .. .. .	188
HAMPSON, G. F.—Indian Moths .. .. .	189
BORDAS—Salivary Glands of Hymenoptera .. .. .	189
MARCHAL, P.—Reproduction of Wasps .. .. .	190
GRASSI, B., & A. SANDIAS—Termite Societies .. .. .	190
BRUYANT, CH.—A Stridulating Aquatic Hemipteron .. .. .	191
PEYTOUREAU—Anatomy and Development of Female Genital Armature of <i>Orthoptera</i> .. .. .	191

## B. Myriopoda.

VERHOEFF, C.— <i>Chordeuma germanicum</i> .. .. .	191
---	-----

## γ. Protracheata.

DENDY, A.—Hatching of a <i>Peripatus</i> Egg .. .. .	191
--	-----

## δ. Arachnida.

BERNARD, H. M.—Endosternite of <i>Scorpio</i> .. .. .	192
LAURIE, M.—Anatomy and Relations of <i>Eurypteridæ</i> .. .. .	192
SCHIMKEWITSCH, W. M.—Pantopoda of Albatross Expedition .. .. .	193

## ε. Crustacea.

SABATIER, A.—Spermatogenesis in Decapod Crustacea .. .. .	193
CUÉNOT, L.—Physiology of Decapod Crustacea .. .. .	194
WELDON, W. F. R.—Correlated Variations in <i>Carcinus Mænas</i> .. .. .	195
DENDY, A.—Crayfish with Abnormal Appendages .. .. .	195
BERGH, R. S.—Shifting of the Germinal Streak in <i>Gammarus</i> .. .. .	195
HAECKER, V.—Winter and Summer Eggs of <i>Moina</i> .. .. .	196
SAMASSA, P.—Formation of Germinal Layers in <i>Moina</i> .. .. .	196
GRUVEL, A.—Buccal Apparatus of Cirripedia .. .. .	196
HARDY, W. B., & W. McDUGALL—Structure and Functions of Alimentary Canal of <i>Daphnia</i> .. .. .	196
RACOVITZA—Ascothoracida .. .. .	197
BEECHER, C. E.—Thoracic Legs of <i>Triarthrus</i> .. .. .	198

## Vermes.

## a. Annelida.

WAWRZIK, E.—Supporting Tissues of Nervous System of <i>Chaetopoda</i> .. .. .	198
M'INTOSH, W. C.—Tubes formed by Annelids .. .. .	198
CARAZZI, D.—The Genus <i>Polydora</i> .. .. .	199
RACOVITZA, E. G.—Amœbocytes and Oogenesis in <i>Micronereis variegata</i> .. .. .	199
BUCHANAN, F.—A Polynoid with Branchiæ .. .. .	199
COLE, F. J.—Clitellum of Earthworm .. .. .	200
UDE, H.—Exotic Earthworms .. .. .	200
SPENCER, W. BALDWIN—Victorian Earthworms .. .. .	200
BEDDARD, F. E.—South American Tubificidæ .. .. .	200
HESSÉ, R.—Structure of <i>Enchytræidæ</i> .. .. .	201

## B. Nematelminthes.

SALA, L.—Experiments with Ova of <i>Ascaris</i> .. .. .	201
JÄGERSKIÖLD, L. A.—Anatomy of Nematodes .. .. .	202
COBB, N. A.—Australian and Fijian Nematodes .. .. .	202

## γ. Platyhelminthes.

WOODWORTH, W. M' M.—Turbellaria of 'Albatross' Expedition .. .. .	202
DENDY, A.—Land Planarians from Tasmania and South Australia .. .. .	202
PLESSIS, G. DU— <i>Emea lacustris</i> .. .. .	202
LINSTOW, V.—Structure and Life-history of <i>Tæniæ</i> .. .. .	203

## δ. Incertæ Sedis.

SPENGLER, J. W.— <i>Enteropneusta</i> .. .. .	203
RIITTER, W. E.—Larva of <i>Balanoglossus</i> .. .. .	204

Echinoderma.		PAGE
STÜRTZ, B.—Recent and Fossil Starfishes .. .. .		204
PERRIER, E.—Asteroidea of the 'Travailleur' and 'Talisman' Expedition .. .. .		205
FRENZEL, J.—Enteric Canal of Echinoderma .. .. .		206
MACBRIDE, E. W.—Organogeny of <i>Asterina gibbosa</i> .. .. .		206
GARSTANG, W.—Bipinnariæ from the English Channel .. .. .		207
MARENZELLER, E. VON—Holothurians of North Atlantic .. .. .		207

#### Cœlentera.

FOWLER, G. H.— <i>Octineon Lindahli</i> .. .. .	208
DUERDEN, J. E.— <i>Irish Hydroïda</i> .. .. .	208
BALE, W. W.— <i>Australian Hydroïds</i> .. .. .	209

#### Porifera.

MAAS, O.— <i>Development of Cornacuspongix</i> .. .. .	209
LENDEFELD, R. VON— <i>Systematic Position of Placospongia</i> .. .. .	210

#### Protozoa.

BLOCHMANN, F.— <i>Studies on Protozoa</i> .. .. .	210
GRUBER, A.— <i>Microscopic Vivisection</i> .. .. .	210
LINDER— <i>Parasitic Vorticellæ</i> .. .. .	211
WILLACH, P.— <i>Balantidium viride, an Infusorian Pathogenic to Pigeons</i> .. .. .	211
SCHAUDINN, F.— <i>Myxotheca arenilega</i> .. .. .	212
LÉGER, L.— <i>New Gregarine in Algerian Acrididæ</i> .. .. .	212
DANGEARD, P. A.— <i>Polysporella</i> .. .. .	212
EPSTEIN, A.— <i>Monocercomonas Hominis and Amœba coli</i> .. .. .	212
MASSARI, G., & E. FERRONI— <i>Supposed Cancer Parasites</i> .. .. .	213
PAWLOWSKY, A. D.— <i>Parasitic Cell-Inclusions in Sarcomatous Tissue</i> .. .. .	213

### BOTANY.

#### A. GENERAL, including the Anatomy and Physiology of the Phanerogamia.

##### a. Anatomy.

##### (1) Cell-structure and Protoplasm.

ZIMMERMANN, A.— <i>Cell-structure</i> .. .. .	214
CORRENS, C.— <i>Internal Structure of the Cell-wall</i> .. .. .	215
GILSON, E.— <i>Crystallization of Cellulose and Chemical Structure of the Cell-wall</i> .. .. .	215
SCHULZE, E.— <i>Chemistry of the Cell-wall</i> .. .. .	216
KNY, L.— <i>Formation of Folds in Cell-walls</i> .. .. .	216
CORRENS, C.— <i>Transverse Lamellation of the Membrane of Bast-cell</i> .. .. .	216

##### (2) Other Cell-contents (including Secretions).

BÜTSCHLI, O.— <i>Structure of Starch-grains</i> .. .. .	217
FLEURENT, E.— <i>Composition of Vegetable Albuminoids</i> .. .. .	217
SAPOSCHNIKOFF, W.— <i>Accumulation of Carbohydrates in Leaves</i> .. .. .	217
TANRET, C.— <i>Inulin and its Allies</i> .. .. .	217
GHESSLER, R.— <i>Distribution of Oxalic Acid in Plants</i> .. .. .	217
GUIGNARD, L.— <i>Localization of the Active Principles in the Capparidæ, Tropæolæ, Limnanthæ, and Resedacæ</i> .. .. .	218

##### (3) Structure of Tissues.

WARBURG, O.— <i>Influence of Lignification on the Life of the Cell</i> .. .. .	218
HARTIG, R.— <i>Characteristics of Duramen</i> .. .. .	218
ZIMMERMANN, H.— <i>Comparison of Duramen and Albumnum</i> .. .. .	219
FLOT, L.— <i>Internal Percycle</i> .. .. .	219
WALLICZEK, H.— <i>Mucilage of the Membrane of Vegetative Organs</i> .. .. .	219
HOULBERT, C.— <i>Secondary Wood of the Apetalæ</i> .. .. .	220
DANGEARD, P. A.— <i>Seedlings of Coniferæ</i> .. .. .	220
CORDEMOY, H. J. DE— <i>Root of Arborescent Liliacæ</i> .. .. .	221
HEIDEN, H., & C. HOLTERMANN— <i>Anatomy of Combretacæ</i> .. .. .	221
GILG, E.— <i>Anatomy of Afromendoncia and Mendoncia</i> .. .. .	221

##### (4) Structure of Organs.

MEEHAN, T.— <i>Female Catkins in Populus</i> .. .. .	222
HITCHCOCK, A. S.— <i>Opening of the Buds of Woody Plants</i> .. .. .	222
REINECKE, F.— <i>Vernation in the Compositæ, Campanulacæ, and Lobeliacæ</i> .. .. .	222
LOTHELIER, A.— <i>Spiny Plants</i> .. .. .	222
CANDOLLE, C. DE— <i>Comparative Anatomy of Leaves</i> .. .. .	222
ROSS, H.— <i>Leaves of Iridæ</i> .. .. .	222
HOLLE, G.— <i>Anatomy of the Leaves of Sapotacæ</i> .. .. .	223
LIGNIER, O.— <i>Venation of Cycas</i> .. .. .	223



	PAGE
KNY, L.— <i>Laticiferous Hairs of the Cichoriaceæ</i> .. .. .	223
WARMING, E.— <i>Anatomy of Vellosiaceæ</i> .. .. .	223
DROHNIG, M.— <i>Root-tubers</i> .. .. .	223

### β. Physiology.

#### (1) Reproduction and Embryology.

WESTERMAIER, M.— <i>Embryology of Flowering Plants</i> .. .. .	224
KARSTEN, G.— <i>Embryology of Gnetum</i> .. .. .	224
BUSCALIONI, L.— <i>Embryology of Veronica hederæfolia</i> .. .. .	225
ROBERTSON, C., & OTHERS— <i>Cross-Pollination and Self-Pollination</i> .. .. .	225
CARRUTHERS, W.— <i>Cross-Fertilization of Cereals</i> .. .. .	226
TRELEASE, W.— <i>Pollination of Yucca</i> .. .. .	226
HANSGIRG, A.— <i>Red Colour of the Perianth</i> .. .. .	226

#### (2) Nutrition and Growth (including Germination, and Movements of Fluids).

KLEBS, G.— <i>Influence of Light on the Propagation of Plants</i> .. .. .	227
VÖCHTING, H.— <i>Influence of Light on Flowers</i> .. .. .	227
MESHAN, T.— <i>Rhythmic Growth</i> .. .. .	228
KNY, L.— <i>Physiological Function of Anthocyan</i> .. .. .	228
HEGLER, R.— <i>Influence of Mechanical Traction on Growth</i> .. .. .	228

#### (3) Irritability.

HANSGIRG, A.— <i>Movements of Flowers and Leaves</i> .. .. .	229
KLECKER, J. AF.— <i>Movements of the Flowers of Veronica</i> .. .. .	229
SCHOLTZ, M.— <i>Movements of the Flower-stalk of Cobæa</i> .. .. .	229

#### (4) Chemical Changes (including Respiration and Fermentation).

MESNARD, E.— <i>Transformations of Reserve-substances during Germination</i> .. .. .	230
SABLON, LECLERO DU.— <i>Germination of Ricinus</i> .. .. .	230
LINDET, L.— <i>Production of Saccharose in the Germination of Barley</i> .. .. .	230
WEHMER, C.— <i>Function of Citric Acid in Assimilation</i> .. .. .	230

### γ. General.

OLIVER, F. W.— <i>Effects of Fog on Plants</i> .. .. .	231
DEAN, B.— <i>Insectivorous Habit of Dionæa</i> ' .. .. .	231
TIEMANN, F., & P. KRUGER— <i>Perfume of the Violet</i> .. .. .	231

## B. CRYPTOGAMIA.

### Muscineæ.

BESCHERELLE, E., & K. MÜLLER— <i>New Genera of Musci</i> .. .. .	231
BOWER, F. O.— <i>Structure of Buxbaumia</i> .. .. .	232
FARMER, J. B.— <i>Relations of Nucleus to Spore-formation in Liverworts</i> .. .. .	232

### Algæ.

KLEBAHN, H., & A. HANSGIRG— <i>New Genera of Algæ</i> .. .. .	233
DECKENBACH, K.— <i>Polymorphism of Trentepohlia</i> .. .. .	233

### Fungi.

MANGIN, L., & OTHERS— <i>Composition of the Cell-wall of Fungi</i> .. .. .	233
PEGLION, V.— <i>Malformations produced by Cystopus candidus and Ræstelia cancellata</i> .. .. .	234
NILSSON, A., & OTHERS— <i>Parasitic Fungi</i> .. .. .	234
NAWASCHIN, S.— <i>Fungus-parasite of Sphagnum</i> .. .. .	235
WEHMER, C.— <i>Fungi which produce Citric Acid</i> .. .. .	235
MOELLER, M.— <i>Spores of Yeast</i> .. .. .	235
MACH, E., & K. PORTELE— <i>Fermenting Grape- and Apple-must with Pure-bred Yeasts</i> .. .. .	235
JÖRGENSEN, A., & J. CH. HOLM— <i>Effront's Process for Purification and Preservation of Yeast</i> .. .. .	236
FISCHER, B.— <i>New Form of Propagation in Mycoderma</i> .. .. .	236
LAFAB, F.— <i>Acetic Acid-forming Blastomycete</i> .. .. .	236
MÖLLER, A.— <i>Fungus which forms several Different Lichens</i> .. .. .	237
TAVEL, F. V.— <i>Alternation of Generations in the Uredinæx</i> .. .. .	237
SAPPIN-TROUFFY— <i>Suckers of the Uredinæx</i> .. .. .	237
„ <i>Pseudo-fecundation in the Uredinæx</i> .. .. .	238
VUILLEMIN, P.— <i>Fertilization of the Puccinæx</i> .. .. .	238
MAGNUS, P.— <i>Puccinias Parasitic on Compositæ</i> .. .. .	238
FLOWRIGHT, C. B., & OTHERS— <i>Puccinia Paridis and interstitialis</i> .. .. .	238
SCHEWIAKOFF, W.— <i>Achromatium oxaliferum</i> .. .. .	239

## Protophyta.

### a. Schizophyceæ.

	PAGE
LAUTERBORN, R.— <i>Structure and Cell-division of Diatoms</i> .. .. .	239
CASTRACANE & P. MIQUEL— <i>Spores of Diatoms</i> .. .. .	239
MIQUEL, P.— <i>Nucleus of Diatoms</i> .. .. .	240
BRUN, J.— <i>New Genera of Diatoms</i> .. .. .	240
SCHMIDT'S <i>Atlas der Diatomaceen-Kunde</i> .. .. .	240
HIERONYMUS, G., AND OTHERS— <i>Structure of the Cells of Phycochromaceæ</i> .. .. .	240
HANSGIRG, A.— <i>Oscillatoriaceæ</i> .. .. .	241
GOMONT, M.— <i>Phormidium</i> .. .. .	241

### b. Schizomycetes.

WARD, H. MARSHALL— <i>Action of Light on Bacteria</i> .. .. .	241
HANSEN, E. C.— <i>Acetic Acid Bacteria</i> .. .. .	242
HESSE, W.— <i>Gaseous Products of Bacteria</i> .. .. .	242
BEYERINCK, M. W.— <i>Respiration-Figures of Mobile Bacteria</i> .. .. .	242
NOACK, F.— <i>Cancer of the Ash produced by Bacteria</i> .. .. .	243
MACCHIATI, L.— <i>Streptococcus Bombycis and the Silkworm Disease</i> .. .. .	243
SCHÜLLER— <i>Microbes in Chronic Rheumatism</i> .. .. .	243
HANKIN, E. H.— <i>Alezocytes</i> .. .. .	243
MÜNTZ, A., & H. CONDON— <i>Ammoniacal Fermentation of Earth</i> .. .. .	244
DUCLAUX, E.— <i>Microbes and Fatty Matter</i> .. .. .	244
VOGES, O.— <i>Chromogenic Water Bacteria</i> .. .. .	245
FISCHER & LEVY— <i>Presence of Diplococcus pneumoniæ Fraenkel, and of Streptococcus pyogenes in Osteomyelitis and Periostitis</i> .. .. .	245
DENYS, J., & J. MARTIN— <i>Relations of Friedlaender's Pneumobacillus and of the Lactic Ferment with B. lactis aerogenes and B. typhosus</i> .. .. .	245
MÜLLER, K.— <i>Anthrax in Rats</i> .. .. .	246
DANYSZ, J.— <i>Destruction of Field Mice by means of Pathogenic Microbes</i> .. .. .	247
KIESSLING, F.— <i>Vibrio resembling Cholera Bacillus</i> .. .. .	247
HEIDER, A.— <i>Vibrio danubicus</i> .. .. .	247
ABEL, R.— <i>Viability Period of Diphtheria</i> .. .. .	248
ARLOING, S.— <i>Diagnostic Value of the Soluble Products of the Microbe of Peripneumonia bovina</i> .. .. .	248
JAKOWSKI, M.— <i>Mixed Infection from Tubercle Bacilli and Pyogenic Cocci</i> .. .. .	248
ARLOING, S., & E. CHANTRE— <i>Microbic Origin of Purulent Surgical Infection</i> .. .. .	249

## MICROSCOPY.

### a. Instruments, Accessories, &c.

#### (1) Stands.

SWIFT'S <i>New Histological and Physiological Microscope</i> (Figs. 17 and 18) .. .. .	250
BROWN, G. W., JUN.— <i>New Substage</i> .. .. .	252

#### (3) Illuminating and other Apparatus.

SCHROEDER, HUGO— <i>Production of Exact Micrometer-Screws</i> (Figs. 19-21) .. .. .	252
NELSON, E. M.— <i>Construction of Silvered Lens Mirrors</i> (Fig. 22) .. .. .	254

#### (4) Photomicrography.

KÖHLER, A.— <i>New Method of Illumination for Photomicrographical Purposes</i> (Fig. 23) .. .. .	261
BORDEN, W. C.— <i>Stereoscopic Photomicrography</i> .. .. .	262
CUNNINGHAM, K. M.— <i>Remarkable Collection of Photomicrographs</i> .. .. .	262
ATKINSON, G. F.— <i>Photographing Plate Cultivations</i> .. .. .	263

#### (5) Microscopical Optics and Manipulation.

STREHL, K.— <i>Theoretical Limit to the Capacity of the Microscope</i> .. .. .	263
--	-----

#### (6) Miscellaneous.

LIVERPOOL <i>Microscopical Society</i> .. .. .	264
MICROSCOPICAL <i>Society of Calcutta</i> .. .. .	264
THE LATE <i>Mr. C. Haughton Gill, F.R.M.S.</i> .. .. .	264

### b. Technique.

MAREK, J.— <i>Hints in Bacteriological Technique</i> .. .. .	265
BACHMANN, O.— <i>Manual of Microscopical Technique</i> .. .. .	266
PIERSOL'S <i>Histology</i> .. .. .	266

#### (1) Collecting Objects, including Culture Processes.

LUNKIEWICZ, M.— <i>Quadrangular Culture-Capsules</i> .. .. .	266
„ „ <i>Cold Stage</i> .. .. .	266



	PAGE
BEHRENDSEN'S <i>Steam Sterilizer</i> .. .. .	266
KIRCHNER, M.— <i>Berkefeld Filter</i> .. .. .	267
LASER, H.— <i>Apparatus for Boiling and Cooling Water</i> .. .. .	267
SCHILD— <i>Formalin as Test for Typhoid Bacillus</i> .. .. .	268
WURTZ & LERMOYER— <i>Germicidal Properties of Human Mucus</i> .. .. .	268
ROHRER, F.— <i>Antibacterial Action of Oxycrinaseptol</i> .. .. .	268
PARASCANDOLE, C.— <i>Egg-albumen as a Cultivation Medium for Micro-organisms</i> .. .. .	268
NASTUKOW, M.— <i>Egg-yolk Medium for Cultivating Influenza Bacillus</i> .. .. .	269
MAASSEN, A.— <i>Blood-Serum as Diagnostic Cultivation Medium for the Cholera Vibrio</i> .. .. .	269
WORTMANN, J.— <i>Inspissated Must and the Cultivation of Fungi</i> .. .. .	270
ARENS— <i>Plate Cultivations of Anaerobes</i> .. .. .	270
TIMPE, H.— <i>Method for Imparting Correct Reaction to Nutrient Gelatin</i> .. .. .	270
SCHMIDT, A.— <i>Sputum as Cultivation Medium for Pneumonia Cocci</i> .. .. .	271
BIBLIOGRAPHY .. .. .	271

## (2) Preparing Objects.

MIDDLEMASS— <i>Method of Preparing Fresh Sections of Brain</i> .. .. .	271
RATH, O. VOM— <i>Investigation of Spermatogenesis of Salamandra</i> .. .. .	271
BLANC, H.— <i>Preparation of Eggs of Trout</i> .. .. .	272
CONKLIN, E. J.— <i>Preparing Molluscan Ova</i> .. .. .	272
SABATIER, A.— <i>Study of Spermatogenesis of Crustacea</i> .. .. .	272
STILES, C. W.— <i>Preparation of Cestodes</i> .. .. .	273
SCHAUDINN, F.— <i>Investigation of Myxotheca</i> .. .. .	273
BECKER, J.— <i>Method for Obtaining Hæmin Crystals</i> .. .. .	273
FOA, P.— <i>Demonstrating the Cancer Parasite</i> .. .. .	273
WINKLER, F.— <i>Preparing Sections of Living Cultivations without previous Hardening</i> .. .. .	273
POUIKLO, S.— <i>Easy Method for Demonstrating Cholera Vibrios in Water</i> .. .. .	274
BEYERINCK, M. W.— <i>Demonstrating Protozoa and Spirilla in Drinking-water</i> .. .. .	274

## (4) Staining and Injecting.

PARKER, G. H.— <i>Staining Nervous Tissue with Methylen-blue</i> .. .. .	274
STROEBE, H.— <i>Demonstrating Axis-cylinders</i> .. .. .	275
ZIMMERMANN, A.— <i>Staining Crystalloids of Cell-nuclei</i> .. .. .	275
MOELLER, H.— <i>Fixing and Staining the Nuclei and Spores of Yeast</i> .. .. .	276
JAISSON, P.— <i>Staining Spores</i> .. .. .	276
LILJENFELD, L.— <i>Selective Power of Cells in the Absorption of Pigments</i> .. .. .	276
NASTUKOW & PEWSNER— <i>Staining Tubercle Bacilli in Sublimate Solutions of Anilin Dyes</i> .. .. .	276
UNNA, P. G.— <i>Simultaneous Double Stain for Leprosy and Tubercle Bacilli</i> .. .. .	277
RACIBORSKI, v.— <i>Staining-differences of Male and Female Cells</i> .. .. .	277

## (5) Mounting, including Slides, Preservative Fluids, &amp;c.

WIESE, M.— <i>Preservative Fluid for Animals</i> .. .. .	277
BLUM, F.— <i>Formaldehyde for Hardening and Preserving</i> .. .. .	277
LEMAIRE, A.— <i>Microscopical Preparations of Algæ</i> .. .. .	277
TEMPÈRE, J., & P. MIQUEL— <i>Cleaning Diatoms</i> .. .. .	278

## (6) Miscellaneous.

DALAND, JUDSON— <i>New Method of Separating the White from the Red Blood-corpules by means of the Hæmatokrit (Figs. 24-27)</i> .. .. .	278
SIEBEL, J. E.— <i>Bacteriological Examination of Air</i> .. .. .	280
HOFFMANN, L.— <i>Dithion, a New Antiseptic</i> .. .. .	281
DRÄER, A.— <i>Action of some Sozoidol Preparations and of Tribromophenol-Bismuth on Cholera Bacilli</i> .. .. .	281

## PROCEEDINGS OF THE SOCIETY:—

Meeting, 21st February, 1894 .. .. .	282
„ 21st March, 1894 .. .. .	284

Authors of Papers printed in the Transactions are entitled to 20 copies of their communications *gratis*. Extra copies can be had at the price of 10s. 6d. per half-sheet of 8 pages, or less, including cover, for a minimum number of 50 copies, and 6s. per 100 plates, if plain. Prepayment by P.O.O. is requested.

# R. & J. BECK'S LATEST MICROSCOPE.

No. 31. LARGE CONTINENTAL MODEL WITH PERFECT FINE ADJUSTMENT, AND RACK AND PINION (CENTERING) SUBSTAGE.

SPECIALLY ADAPTED FOR BACTERIOLOGY & HIGH-POWER WORK.

MICROTOMES.

—  
CABINETS.

—  
LAMPS.

—  
NEW  
1/12 IN.

OIL-  
IMMERSION  
OBJECT-  
GLASS.

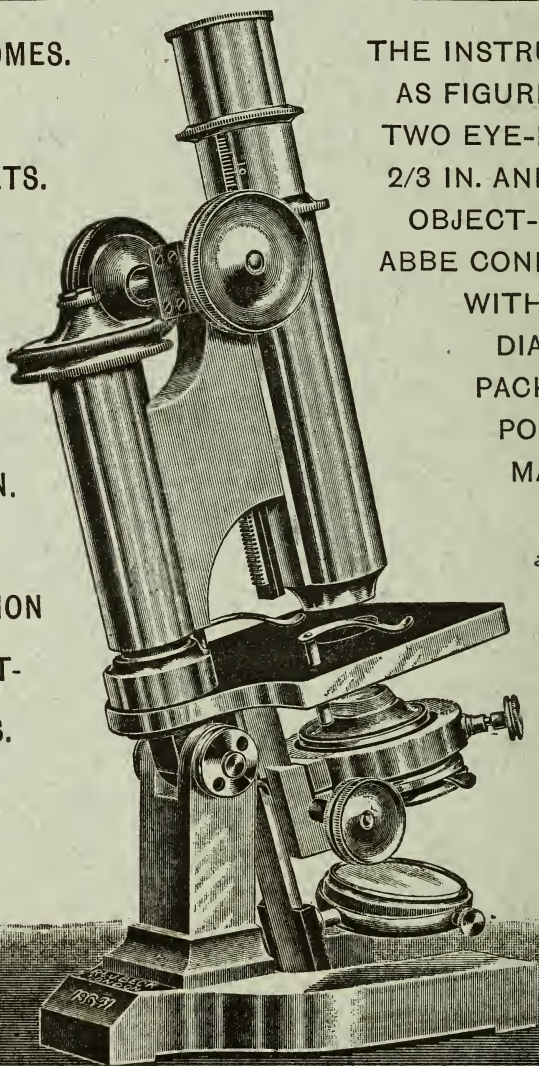

THE INSTRUMENT  
AS FIGURED, WITH  
TWO EYE-PIECES,  
2/3 IN. AND 1/6 IN.  
OBJECT-GLASSES,  
ABBE CONDENSER  
WITH IRIS  
DIAPHRAGM,  
PACKED IN  
POLISHED  
MAHOGANY  
CASE,  
£11 10 0

—  
FULLY  
ILLUSTRATED  
CATALOGUE  
FREE ON  
APPLICATION.

**R. & J. BECK, 68 CORNHILL, LONDON, E.C.**

FACTORY: LISTER WORKS KENTISH TOWN, N.W.



The Journal is issued on the third Wednesday in  
February, April, June, August, October, and December.

1894. Part 3.

JUNE.

{ To Non-Fellows,  
Price 6s.

6994

# JOURNAL

OF THE

# ROYAL

# MICROSCOPICAL SOCIETY;

100. 6 1894

CONTAINING ITS TRANSACTIONS AND PROCEEDINGS,

AND A SUMMARY OF CURRENT RESEARCHES RELATING TO

ZOOLOGY AND BOTANY

(principally Invertebrata and Cryptogamia),

MICROSCOPY, &c.

*Edited by*

**F. JEFFREY BELL, M.A.,**

*One of the Secretaries of the Society*

*and Professor of Comparative Anatomy and Zoology in King's College;*

WITH THE ASSISTANCE OF THE PUBLICATION COMMITTEE AND

**A. W. BENNETT, M.A., B.Sc., F.L.S.,**

*Lecturer on Botany at St. Thomas's Hospital,*

**R. G. HEBB, M.A., M.D. (Cantab.), AND**

**J. ARTHUR THOMSON, M.A.,**

*Lecturer on Zoology in the School of Medicine,*

*Edinburgh,*

FELLOWS OF THE SOCIETY.



LONDON:

TO BE OBTAINED AT THE SOCIETY'S ROOMS,

20 HANOVER SQUARE, W.;

OF MESSRS. WILLIAMS & NORGATE; AND OF MESSRS. DULAU & CO.

# CONTENTS.

## TRANSACTIONS OF THE SOCIETY—

	PAGE
VI.—NOTES ON THE UROPODINÆ. By A. D. Michael, P.R.M.S., F.L.S., F.Z.S., &c. (Plates VI. and VII.) .. .. .	289

### SUMMARY OF CURRENT RESEARCHES.

#### ZOOLOGY.

#### A. VERTEBRATA:—Embryology, Histology, and General.

##### a. Embryology.

ROUX, W.— <i>Experimental Embryology</i> .. .. .	320
HUBRECHT, A. A. W.— <i>Placentation of the Shrew</i> .. .. .	321
KIP, M. J. VAN EBP TAALMAN— <i>Development of Müllerian Duct in Mammals</i> .. .. .	322
PRENANT, M. A.— <i>Development of Thymus, Thyroid, and Carotid Glands</i> .. .. .	323
BAMBEKE, C. VAN— <i>Median Groove of Triton</i> .. .. .	324
BLANC, H.— <i>Fecundation of Egg of Trout</i> .. .. .	324
HASSE, C.— <i>Vertebral Column of Ganoids</i> .. .. .	324
JUNGENSEN, H. F. E.— <i>Development of Kidneys in Sturgeon</i> .. .. .	325
MINOT, C. S.— <i>Bibliography of Vertebrate Embryology</i> .. .. .	325

##### β. Histology.

RAMON Y CAJAL— <i>Minute Structure of Nerve-centres</i> .. .. .	325
LENHOSSÉK, M. V.— <i>Nerve-cord of Rays</i> .. .. .	326
ZOJA, L. & R.— <i>Altmann's Bioplasts</i> .. .. .	326
DRÜNER, L.— <i>Degeneration of Cells and Nuclei</i> .. .. .	326
HANSEMANN, D.— <i>Specific Character of Cell-divisions</i> .. .. .	326
DEMOOR, J.— <i>Physiology of the Cell</i> .. .. .	326

##### γ. General.

SCHIMKÉWITCH, W.— <i>Genetic Relations of Metazoa</i> .. .. .	327
JELLIFFE, S. E.— <i>Organisms in the Chicago Water Supply</i> .. .. .	328

#### B. INVERTEBRATA.

DANBY, W. H., & OTHERS— <i>Natural History of British Columbia</i> .. .. .	328
--	-----

##### Mollusca.

##### a. Cephalopoda.

PERRIER, E., & M. A. T. DE ROCHEBRUNE— <i>Brooding Habits of Octopus Digueti</i> .. .. .	328
--	-----

##### γ. Gastropoda.

OSWALD, A.— <i>Proboscis of Prosobranchs</i> .. .. .	328
TOURENG— <i>Nervous System of Dreissensia polymorpha</i> .. .. .	328
PLATE, L.— <i>Gadinia peruviana</i> .. .. .	329
ANDRÉ, E.— <i>Anatomy and Physiology of Ancyclus lacustris and A. fluviatilis</i> .. .. .	329

##### δ. Lamellibranchiata.

STAUFFACHER, H.— <i>Oogenesis and Segmentation in Cyclas</i> .. .. .	330
--	-----

##### Molluscoïda.

##### a. Tunicata.

WILLEY, A.— <i>Evolution of Præoral Lobe</i> .. .. .	330
CAULLERY— <i>Genital Products in Polyclinidæ</i> .. .. .	330
SALENSKY, W.— <i>Metamorphosis of Distaplia magnilara</i> .. .. .	330
TODARO, F.— <i>Visual Organ of Salpa</i> .. .. .	331

##### Arthropoda.

KINGSLEY, S. J.— <i>Classification of Arthropoda</i> .. .. .	331
--	-----

a. Insecta.

PAGE

PEYTOUREAU, A.—Anatomy and Development of Male Genital Armature of Lepidoptera .. .. . 332  
 " " Female Genital Armature of Lepidoptera .. .. . 332  
 EMERY, C.—Evolution of the Worker-Caste among Ants .. .. . 332  
 JANET, C.—Production of Sound by Ants .. .. . 334  
 " Antennary Nerves and Chordotonal Organs in Ants .. .. . 334  
 KÜNCHEL D'HERCULAIS, J.—Hypermetamorphosis of Cantharidinæ .. .. . 334  
 BORDAS—Salivary Glands of Crabronidæ .. .. . 334  
 " Tracheal System of Larval Hymenoptera .. .. . 334  
 GILSON, G.—Formation of Silk .. .. . 334

B. Myriopoda.

VERHOEFF, C.—Developmental Stages of Julidæ .. .. . 335  
 ADENSAMER, TH.—Eyes of Scutigera coleoptrata .. .. . 335

δ. Arachnida.

PURCELL, F.—Eyes of Harvestmen .. .. . 355  
 LANCE, D.—Revival of Tardigrades .. .. . 335  
 BEECHER, C. E.—Appendages of Pygidium of Triarthrus .. .. . 335  
 PATTEN, W.—Artificial Segmentation of Limulus .. .. . 336

ε. Crustacea.

CHUN, C.—Luminous Organs and Compound Eyes .. .. . 336  
 GROOM, T. T.—Early Development of Cirripedia .. .. . 337  
 AURIVILLIUS, C. W. S.—Post-embryonic Development of Lepadidæ .. .. . 338  
 BRAUER, A.—Parthenogenesis of Artemia .. .. . 339  
 SCHMEIL, O.—Harpacticidæ .. .. . 339

Vermes.

a. Annelida.

BRAEM, F.—Development of Orphryotrocha .. .. . 340  
 SCHAEPI, TH.—Chloragogen of Ophelia radiata .. .. . 341  
 MARENZELLER, E. VON—Deep-sea Polychæta of Eastern Mediterranean .. .. . 342  
 GIARD, A.—New Phreoryctes .. .. . 342  
 EISEN, G.—Californian Eudrilidæ .. .. . 342  
 HORST, R.—Earthworms from the Congo .. .. . 343  
 WILLIAMSON, H. C.—Bifid Earthworm .. .. . 343  
 GRAF, A.—Excretory System of Nephelis .. .. . 343  
 BLANCHARD, R.—Leeches of the Iberian Peninsula .. .. . 343  
 MOORE, J. PERCY—Leech-like Parasites of American Crayfish .. .. . 343  
 BLANCHARD, R.—Notes on Hirudinea .. .. . 344

B. Nemathelminthes.

CAMERANO, L.—Notes on Gordii .. .. . 344

γ. Platyhelminthes.

BÜRGER, O.—Developmental History of Nemertines .. .. . 344  
 BERGENDAL, D.—Polyostia similis .. .. . 345  
 WARD, H. B.—Distomum Westermanni in the United States .. .. . 345  
 GOTO, SEITARO—Canal of Laurer .. .. . 345  
 STILES, C. W., & A. HASSALL—Adult Cestodes of Cattle, Sheep, and Allied Animals .. .. . 345  
 BRAUN, M.—Cystic Worms of Bothriocephalus in German Fishes .. .. . 346

δ. Incertæ Sedis.

DIXON-NUTTALL, F. R.—Notes on Rotifers .. .. . 346

Echinoderma.

HERBST, C., & OTHERS—Experimental Embryology illustrated by Echinoderms .. 346  
 MARENZELLER, E. v.—Deep-Sea Echinoderms of Eastern Mediterranean .. .. . 348  
 LORIOL, P. DE—Echinoderms of the Bay of Amboyna .. .. . 349  
 " Ophiuroids of Mauritius .. .. . 349  
 CAPELLINI, G.—Rhizoerinus Sautagatai .. .. . 349

Cœlentera.

CHAPEAU, MARCELLIN—Digestion of Cœlentera .. .. . 350  
 CARLGREEN, O.—Mingadæ .. .. . 350



	PAGE
STUDER, T.— <i>Acyonaria of the Albatross</i> .. .. .	350
CLARKE, S. F.— <i>Hydroids of the Albatross</i> .. .. .	351
GÜNTHER, R. T.— <i>Minute Anatomy of Limnocoedium</i> .. .. .	351
GUERNE, J. DE— <i>Freshwater Medusa from the Niger</i> .. .. .	351
OSBORN, H. L., & C. W. HARGITT— <i>Perigonimus</i> .. .. .	351

### Porifera.

SCHULZE, F. E.— <i>Hexactinellid Spicules</i> .. .. .	352
TOPSENT, E.— <i>New Sponges</i> .. .. .	352

### Protozoa.

SCHEWIAKOFF, W.— <i>So-called Excretory Granules of Infusorians</i> .. .. .	352
GREENWOOD, M.— <i>Food-vacuoles of Infusoria</i> .. .. .	353
SCHAUDINN, F.— <i>Reproduction of Foraminifera</i> .. .. .	353
EGGER, J. G.— <i>Foraminifera of the Gazelle</i> .. .. .	354
SHERBORN, C. DAVIES— <i>Index to Foraminifera</i> .. .. .	354
MASSART, J.— <i>Irritability of Noctiluca</i> .. .. .	354
CELLI, A., & R. FIOCCA— <i>Amæbæ and their Cultivation</i> .. .. .	354
THÉLOHAN, P.— <i>Interrelations of Myxosporidia</i> .. .. .	355
PODWYSOZKY, W.— <i>Development of Coccidium oviforme in Bile-duct of Rabbits</i> .. .. .	355
KURLOFF, M.— <i>Parasite of Skin Cancer</i> .. .. .	355
SAWTSCHENKO— <i>Cancer Parasite</i> .. .. .	356
SAKHAROFF, N.— <i>Influence of Cold on Vitality of Malaria Parasites</i> .. .. .	357
"    " <i>Hæmatozoa of Birds</i> .. .. .	357
DANILEWSKY, W.— <i>Hæmatozoa in Animals</i> .. .. .	357

## BOTANY.

### A. GENERAL, including the Anatomy and Physiology of the Phanerogamia.

#### a. Anatomy.

##### (1) Cell-structure and Protoplasm.

KLEMM, P., & T. BOKORNY— <i>Aggregation of Protoplasm</i> .. .. .	359
CRATO, E.— <i>Physodes</i> .. .. .	359
SCHNEIDER, A.— <i>Plasomes</i> .. .. .	360
KARSTEN, G.— <i>Nucleoles and Centrosomes in Psilotum</i> .. .. .	360
WILDEMAN, E. DE— <i>Formation of Cell-walls</i> .. .. .	360
RIMPACH, A.— <i>Waviness of the Cell-wall of the Exoderm of Roots</i> .. .. .	360

##### (2) Other Cell-contents (including Secretions).

FERMI, C., & L. PERNOSI— <i>Enzymes</i> .. .. .	360
BRAEMER, L.— <i>Localization of the Active Principles of the Cucurbitaceæ</i> .. .. .	361
TONI, G. B. DE— <i>Localization of Nicotine in the Tobacco-plant</i> .. .. .	361
REINITZER, F.— <i>Fatigue-Substances</i> .. .. .	361

##### (3) Structure of Tissues.

FLOT, L.— <i>Perimedullary Zone</i> .. .. .	361
SCHENK, H.— <i>Flexibility of the Stem of Climbing Plants</i> .. .. .	362
TIEGHEM, P. VAN— <i>Structure of Thymeleaceæ and Peneaceæ</i> .. .. .	362
WEYLANDT, J.— <i>Anatomy of Galegææ</i> .. .. .	362
QUEVA, C.— <i>Anatomy of Ataccia</i> .. .. .	362
SABLON, LECLERC DU— <i>Anatomy of the Stem of Wistaria sinensis</i> .. .. .	363

##### (4) Structure of Organs.

RECHINGER, C.— <i>Divisibility of Organs</i> .. .. .	363
VUILLEMIN, P.— <i>Spurs of Tropæolum and Pelargonium</i> .. .. .	363
JACK, J. G.— <i>Fructification of Juniperus</i> .. .. .	363
LIGNIER, O.— <i>Fruit of Bennettites</i> .. .. .	363
CELAKOVSKY, L.— <i>Navel of the Apophyse of the Fruit-scales of Pinus</i> .. .. .	364
MACFARLANE, J. M.— <i>Pitched Insectivorous Plants</i> .. .. .	364
KOCH, L.— <i>Vegetative Branching</i> .. .. .	364
HOHENAUER, F.— <i>Stem of Grasses</i> .. .. .	365
LOTSY, J. P.— <i>Knees of Tazodium distichum</i> .. .. .	365
HEINIG, R. L.— <i>Blind Root-suckers of Swamp-forests</i> .. .. .	365



	PAGE
MÜLLER, J.— <i>Succulent Compositæ</i> .. .. .	365
HARSHBERGER, J. W.— <i>Anatomy of Maize</i> .. .. .	366
BRAND, F.— <i>Leaves of Nymphaeaceæ</i> .. .. .	366
SAUVAGEAU, C.— <i>Leaf of Butomaceæ</i> .. .. .	366
IHERING, R. v.— <i>Fall of Leaves</i> .. .. .	366
LINSBAUER, L.— <i>Stipules of Euonymus</i> .. .. .	366
PENZIG, O., & A. NESTLER— <i>Pearl-glands</i> .. .. .	367
NICHOLS, M. A.— <i>Achenial Hairs of Compositæ</i> .. .. .	367
WIDENMANN, VON— <i>Hairs of Tilia argentea</i> .. .. .	367
CLOS, D.— <i>Classification of Tubers</i> .. .. .	367

### β. Physiology.

#### (1) Reproduction and Embryology.

MOTTIER, D. M.— <i>Embryo-sac of Acer rubrum</i> .. .. .	367
KAYSER, G.— <i>Nucellus of the Ovule of Croton</i> .. .. .	368
GILTAY, E.— <i>Influence of the Pollen on the Fruit and Seed</i> .. .. .	368
JURÁNYI, L.— <i>Fertilization of Gymnosperms</i> .. .. .	368

#### (2) Nutrition and Growth (including Germination, and Movements of Fluids).

RAUNKJÆR, C.— <i>Distribution of Seeds of the Cyperaceæ</i> .. .. .	368
PETER, A.— <i>Germination of Dormant Seeds</i> .. .. .	368
BENECKE, F.— <i>Rapidity of Growth</i> .. .. .	369
SCHWENDENER, S., & G. KRABBE— <i>Relation between Tension and Growth in Length</i> .. .. .	369
SACHS, J.— <i>Periods of Growth and Causes of Development</i> .. .. .	369
DARWIN, F.— <i>Growth of the Fruit of Cucurbita</i> .. .. .	369
ZIEGENBEIN, E.— <i>Metastasis and Respiration in Germinating Tubers and Seeds</i> .. .. .	370
NOLL, F.— <i>Transpiration of Succulent Plants</i> .. .. .	370

#### (3) Irritability.

PFEFFER, W.— <i>Irritability</i> .. .. .	370
NOLL, F.— <i>Geotropism and Epinasty</i> .. .. .	370
McDOUGAL, D. T.— <i>Intertwining of Tendrils</i> .. .. .	371
HALSTED, B. D.— <i>Heliotropism of the Mallow</i> .. .. .	371

#### (4) Chemical Changes (including Respiration and Fermentation).

BARNES, C. R.— <i>Food of Green Plants</i> .. .. .	371
PFEFFER, W.— <i>Causes of the Disappearance of Reserve Food-materials from Seeds</i> .. .. .	371
PALLADINE, W.— <i>Respiration of Green and Etiolated Leaves</i> .. .. .	371
TSCHIRCH, A.— <i>Formations of Resins and Essential Oils</i> .. .. .	372
ACQUA, C.— <i>Formation of Starch in Pelargonium zonale</i> .. .. .	372
LOEW, O.— <i>Alkaline Reaction of Aquatic Plants</i> .. .. .	372

### γ. General.

BONNIER, G.— <i>Vegetable Heat</i> .. .. .	372
MAYER, A. G.— <i>Radiation and Absorption of Heat by Leaves</i> .. .. .	373
GAYON, U., & E. DUBOURG— <i>Presence of Mannite in Wine (Mannitic Ferment)</i> .. .. .	373

## B. CRYPTOGAMIA.

### Cryptogamia Vascularia.

ATKINSON, G. F.— <i>Embryo of Ferns</i> .. .. .	373
"   " <i>Annulus of the Sporangium of Ferns</i> .. .. .	374
POTONÉ, H.— <i>Classification of Siggillariæ</i> .. .. .	374
ZEILLER, R.— <i>Sphenophyllum</i> .. .. .	374

### Muscineæ.

BRAITHWAITE'S <i>British Moss-Flora</i> .. .. .	374
GOEBEL, K.— <i>Vegetative Structure of Hepaticæ</i> .. .. .	374
RUGE, G.— <i>Vegetative Organs of Hepaticæ</i> .. .. .	375
REEVES, J.— <i>Stem and Leaves of Physotium</i> .. .. .	375

### Algæ.

BARTON, B. W.— <i>Stichids and Tetrasporanges of Dasya</i> .. .. .	376
SCHMITZ, F., & M. GOMONT— <i>Actinococcus</i> .. .. .	376
KLEMM, P.— <i>Structure of Caulerpa</i> .. .. .	376
FRANZÉ, R. H.— <i>Low Forms of Algæ</i> .. .. .	376

Fungi.		PAGE
BOURQUELOT, E.— <i>Ferment in Fungi</i> .. .. .		377
CSAPODI, S.— <i>Fungi which Feed on Arsenic</i> .. .. .		377
WILDEMAN, E. DE.— <i>Lagenidium and Chytridiaceæ</i> .. .. .		377
BOULANGER, E., & OTHERS— <i>New Genera of Fungi</i> .. .. .		378
LAPINE, N., & OTHERS— <i>Parasitic Fungi</i> .. .. .		378
WEHMER, C.— <i>Development of Penicillium luteum</i> .. .. .		379
HEIM, F.— <i>Aspergillus developing in Sulphate of Quinine</i> .. .. .		380
MASSE, G.— <i>Trichosphæria Sacchari</i> .. .. .		380
MÜLLER, J.— <i>Wrinkle-scurf</i> .. .. .		380
CARLETON, C. A.— <i>Germination of the Uredinæ</i> .. .. .		380
WAGER, H.— <i>Nuclear Division in the Hymenomyces</i> .. .. .		380
FISCHER, E.— <i>Phalloidæ</i> .. .. .		381
JANCZEWSKI, A. DE.— <i>Position of Pompholyx</i> .. .. .		381

## Protophyta.

### a. Schizophyceæ.

WILDEMAN, E. DE, & OTHERS— <i>Scenedesmus</i> .. .. .	381
WILDEMAN, E. DE— <i>New Pleurococcus</i> .. .. .	382
TONI, G. B. DE— <i>Intra-frustular Reproduction of Diatoms</i> .. .. .	382
MÜLLER, O.— <i>Movements of Diatoms</i> .. .. .	382
SCHÜTT, F.— <i>Relationship between the Morphology and Biology of Diatoms and their Classification</i> .. .. .	382
PALLA, E., & H. ZUKAL— <i>Protoplasts of the Cyanophyceæ</i> .. .. .	383

### b. Schizomycetes.

TOLOMEI, G.— <i>Action of Ozone on Micro-organisms</i> .. .. .	383
COHN, F.— <i>Thermogenous Bacteria</i> .. .. .	384
HANSEN, E. C.— <i>Aceto-bacteria</i> .. .. .	384
MAUMUS— <i>Conversion of Starch into Sugar by Bacillus anthracis</i> .. .. .	384
SAKHAROFF, N.— <i>Composite Cilia of Bacillus</i> .. .. .	384
SMITH, TH.— <i>Gas and Acid Production by Bacteria</i> .. .. .	384
BLACHSTEIN— <i>Pathogenic Properties of Water Microbes</i> .. .. .	385
ILKEWICZ, W.— <i>Nuclei of Anthrax Spores</i> .. .. .	385
METSCHNIKOFF, E.— <i>Phagocytosis</i> .. .. .	385
HAMBURGER, H. J.— <i>New Bacterium of the Lymph</i> .. .. .	386
GÄRTNER, F.— <i>New Gas-forming Bacillus</i> .. .. .	387
DAHMEN, MAX— <i>Bactericidal Properties of Vasogen</i> .. .. .	387
SANFELICE, F.— <i>Influence of Physico-Chemical Agents on some Pathogenic Anaerobes of the Soil</i> .. .. .	387
GERMANO & MAUREA— <i>Differences between Bacillus typhosus and "Typhoid" Bacilli</i> .. .. .	387
DÉLÉPINE, SHERIDAN— <i>Value of Bacteriological Diagnosis of Asiatic Cholera</i> .. .. .	388
TERNI, C.— <i>Characteristic Mobility of the Typhoid Bacillus</i> .. .. .	388
SAINT-SEVRIN, DU BOIS— <i>Red Cocco-bacillus of the Sardine</i> .. .. .	389
LASER, H.— <i>Laser's Bacillus of Mouse-disease</i> .. .. .	390
VINCENT, H.— <i>Parasite of the Madura Foot</i> .. .. .	390
BIBLIOGRAPHY .. .. .	391

## MICROSCOPY.

### a. Instruments, Accessories, &c.

#### (1) Stands.

AMANN, J.— <i>Some Improvements and Additions to the Microscope Stand</i> .. .. .	392
---	-----

#### (3) Illuminating and other Apparatus.

LAFAR, F.— <i>Counting Apparatus specially adapted for Petri's Capsules (Fig. 28)</i> .. .. .	393
---	-----

#### (4) Photomicrography.

NEUHAUSS, R.— <i>Photomicrography and Projection</i> .. .. .	393
ENGEL, S.— <i>Simple Photomicrographic Camera</i> .. .. .	393
HANSEMANN— <i>Stereoscopic Photomicrography</i> .. .. .	393
KARG, K.— <i>Photomicrograms for Purposes of Instruction</i> .. .. .	394
NELSON, E. M.— <i>Hints on Photomicrography</i> .. .. .	394



## (5) Microscopical Optics and Manipulation.

PAGE

TUTTON, A. E.— <i>An Instrument of Precision for producing Monochromatic Light of any desired Wave-length, and its Use in the Investigation of the Optical Properties of Crystals</i> .. .. .	394
FOCK, A.— <i>The Limits of the Visible</i> .. .. .	395

## (6) Miscellaneous.

BEDOT, M.— <i>The late Prof. Fol</i> .. .. .	395
--	-----

## b. Technique.

DEL RIO Y LARA, D. LUIS— <i>Manual of Technique</i> .. .. .	396
---	-----

## (1) Collecting Objects, including Culture Processes.

SCHERFFEL, A.— <i>Improvement in J. af Klercker's Arrangement for the Cultivation of Living Organisms under the Microscope (Fig. 29)</i> .. .. .	396
NOVY, F. G.— <i>Apparatus for Cultivating Anaerobic Bacteria (Figs. 30-31)</i> .. .. .	397
CRISTIANI, H.— <i>Apparatus for Bacteriological Examination of Air (Fig. 32)</i> .. .. .	398
KUTSCHER— <i>Absence of Phosphorescence in Cholera Cultures</i> .. .. .	399
WESENER— <i>Preparation of Nutrient Medium for Bacteria from Eggs</i> .. .. .	399
VOGES, O.— <i>Cultivation of Cholera in Ushinsky's Medium</i> .. .. .	400
KUPRIANON, J.— <i>Obtaining Germ-free Blood-serum</i> .. .. .	400

## (2) Preparing Objects.

BORREL, A.— <i>Technique for Studying Tubercle Bacilli in Lung</i> .. .. .	401
ILKEWITSCH, K.— <i>New Method for Detecting Tubercle Bacilli in Phthisical Sputum</i> .. .. .	402
CLAYPOLE, E. J.— <i>Investigation of Blood of Necturus and Cryptobranchus</i> .. .. .	402
ANDRÉ, E.— <i>Investigation of Ancyclus</i> .. .. .	402
GROOM, T. T.— <i>Development of Cirripedia</i> .. .. .	403
JULIEN, A. A.— <i>Preparing and Staining Cover-glass Preparations</i> .. .. .	403

## (3) Cutting, including Imbedding and Microtomes.

SCHIEFFERDECKER, P.— <i>New Double-knife (Fig. 33)</i> .. .. .	403
ELSCHING, A.— <i>Imbedding Delicate Objects in Celloidin</i> .. .. .	404
„ „ <i>Air- and Water-free Celloidin Solutions</i> .. .. .	404

## (4) Staining and Injecting.

KANTOROWICZ— <i>Use of Thionin</i> .. .. .	405
PIANESE, G.— <i>Formic Acid Hæmatozylin</i> .. .. .	405
ERMENGEM, E. VAN— <i>New Method of Staining Cilia of Bacteria</i> .. .. .	405
SOLAVO— <i>Method for Staining Flagella</i> .. .. .	405
NICOLLE, M., & V. MORAX— <i>Staining Flagella</i> .. .. .	406
ILKEWICZ, W.— <i>Staining Nuclei of Anthrax Spores</i> .. .. .	406
SAWTSCHENKO— <i>Microchemical Staining Reactions of Mucin</i> .. .. .	407
EHRMANN, S.— <i>Weigert's Fibrin Method</i> .. .. .	407

## (5) Mounting, including Slides, Preservative Fluids, &amp;c.

FABRE-DOMERGUE— <i>Slide-holder (Fig. 34)</i> .. .. .	407
---	-----

## (6) Miscellaneous.

GOETHART, J. W. CHR.— <i>Drawing imperfectly visible Details, with Camera lucida</i> .. .. .	408
--	-----

## PROCEEDINGS OF THE SOCIETY:—

Conversazione, 4th April, 1894 .. .. .	409
Meeting, 18th April, 1894 .. .. .	413
Meeting, 16th May, 1894 .. .. .	417

Authors of Papers printed in the Transactions are entitled to 20 copies of their communications *gratis*. Extra copies can be had at the price of 10s. 6d. per half-sheet of 8 pages, or less, including cover, for a minimum number of 50 copies, and 6s. per 100 plates, if plain. Prepayment by P.O.O. is requested.

# R. & J. BECK'S MICROSCOPES

FIRST CLASS  
 OBJECT  
 GLASSES.  
 —  
 MICROTOMES  
 —  
 LAMPS.  
 —  
 OBJECTS.  
 —  
 CABINETS.  
 —  
 APPARATUS.

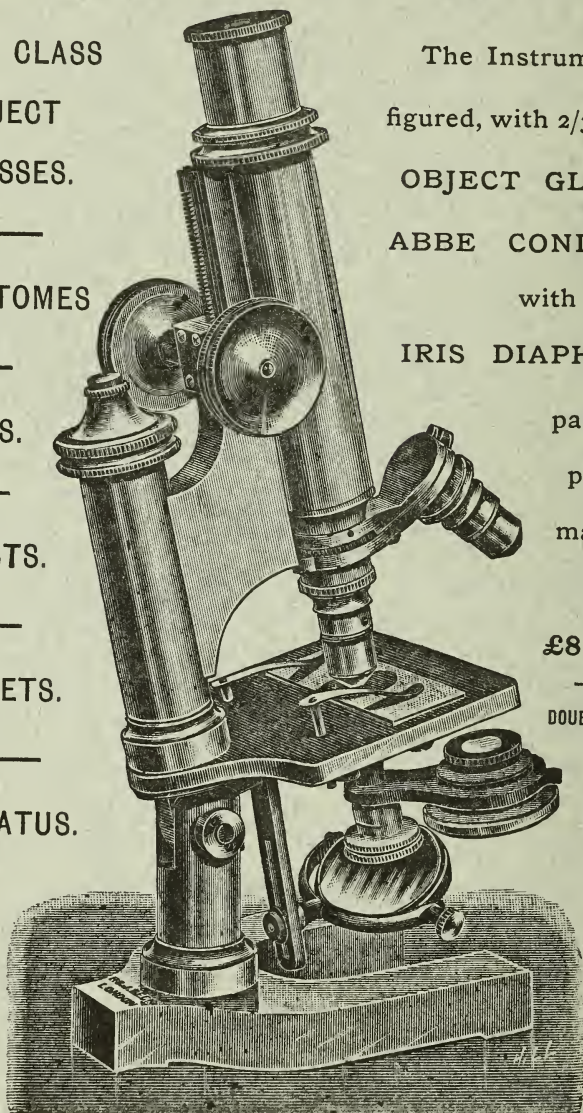

The Instrument as  
 figured, with  $\frac{2}{3}$  &  $\frac{1}{6}$  in.  
 OBJECT GLASSES,  
 ABBE CONDENSER  
 with  
 IRIS DIAPHRAGM,  
 packed in  
 polished  
 mahogany  
 case,  
 £8 15s. 0d.  
 DOUBLE NOSEPIECE,  
 16s. 6d.  
 EXTRA.

No. 29.—New Form CONTINENTAL MODEL MICROSCOPE.

FULL ILLUSTRATED DESCRIPTIVE CATALOGUE FREE ON APPLICATION.

**R. & J. BECK, 68 CORNHILL, LONDON, E.C.**  
 FACTORY: LISTER WORKS, KENTISH TOWN, N.W.



The Journal is issued on the third Wednesday in  
February, April, June, August, October, and December.

1894. Part 4. 6994 AUGUST.

To Non-Fellows,  
Price 6s.

# JOURNAL OF THE ROYAL MICROSCOPICAL SOCIETY;

CONTAINING ITS TRANSACTIONS AND PROCEEDINGS,

AND A SUMMARY OF CURRENT RESEARCHES RELATING TO

ZOOLOGY AND BOTANY

(principally Invertebrata and Cryptogamia),

MICROSCOPY, &c.

*Edited by*

**F. JEFFREY BELL, M.A.,**

*One of the Secretaries of the Society*

*and Professor of Comparative Anatomy and Zoology in King's College;*

WITH THE ASSISTANCE OF THE PUBLICATION COMMITTEE AND

**A. W. BENNETT, M.A., B.Sc., F.L.S.,**

*Lecturer on Botany at St. Thomas's Hospital,*

**R. G. HEBB, M.A., M.D. (Cantab.),** AND

**J. ARTHUR THOMSON, M.A.,**

*Lecturer on Zoology in the School of Medicine,*

*Edinburgh,*

FELLOWS OF THE SOCIETY.



LONDON:

TO BE OBTAINED AT THE SOCIETY'S ROOMS,

20 HANOVER SQUARE, W.;

OF MESSRS. WILLIAMS & NORGATE; AND OF MESSRS. DULAU & CO.

# CONTENTS.

## TRANSACTIONS OF THE SOCIETY—

	PAGE
VII.—THE FORAMINIFERA OF THE GAULT OF FOLKESTONE.—VI. By Frederick Chapman, F.R.M.S. (Plate VIII.) .. ..	421
VIII.—ON THE UNRELIABILITY OF CERTAIN CHARACTERS, GENERALLY ACCEPTED FOR SPECIFIC DIAGNOSIS IN THE DIATOMACEÆ. By Thomas Comber, F.R.M.S., F.L.S. .. .. .	428

## SUMMARY OF CURRENT RESEARCHES.

### ZOOLOGY.

#### A. VERTEBRATA:—Embryology, Histology, and General.

##### a. Embryology.

SEDGWICK, A.— <i>Von Baer's Law and the Significance of Ancestral Rudiments in Embryonic Development</i> .. .. .	433
WEISMANN, A.— <i>Effect of External Conditions on Development</i> .. .. .	434
ZIEGLER, H. E.— <i>Yolk-nuclei in Meroblastic Ova</i> .. .. .	435
BLANC, H.— <i>Fertilization of Trout's Ovum</i> .. .. .	435
RÖSE, C.— <i>Development of the Teeth in the Adder</i> .. .. .	435
FIELD, H. H.— <i>Development of Excretory System in Amphiuma</i> .. .. .	435
BEARD, J.— <i>Development of the Thymus</i> .. .. .	436
LENDENFELD, R. VON— <i>Haacke's Theory of Gemmaria</i> .. .. .	436

##### b. Histology.

MINCHIN, E. A.— <i>Microscopic Foam and Protoplasm</i> .. .. .	437
BERNARD, H. M.— <i>Relations of Isotropous to Anisotropous Layers in Striped Muscles</i> .. .. .	437

##### c. General.

WALLACE, A. R.— <i>Zoological Regions</i> .. .. .	437
FREDERICQ, L.— <i>Autotomy in the Animal Kingdom</i> .. .. .	438
HERDMAN— <i>Zoology of Irish Sea</i> .. .. .	438
FREBAULT, A.— <i>Chemistry of Organisms</i> .. .. .	438
GARSTANG, W.— <i>Phylogeny of Chordata</i> .. .. .	438

#### B. INVERTEBRATA.

ALCOCK, A.— <i>Deep-sea Invertebrates of Indian Ocean</i> .. .. .	439
GIARD, A.— <i>Dimorphism due to Parasitism</i> .. .. .	439
LAUTERBOEN, R.— <i>Winter Fauna of the Upper Rhine</i> .. .. .	440

##### Mollusca.

FRENZEL, J.— <i>Histology of Mid-gut Gland</i> .. .. .	440
--	-----

##### c. Gastropoda.

SAMASSA, P.— <i>Nerves of Oculiferous Tentacle of Helix pomatia</i> .. .. .	440
HENKING, H.— <i>Hydrobia ulvæ</i> .. .. .	440
PLATE, L.— <i>Circulatory and Renal Organs of Chitons</i> .. .. .	440

##### d. Lamellibranchiata.

NAGEL, W. A.— <i>Sense of Light in Eyeless Bivalves</i> .. .. .	441
TOURENG— <i>Circulatory System of Dreissensia polymorpha</i> .. .. .	442

##### Molluscoïda.

##### a. Tunicata.

SEELIGER, O.— <i>So-called Segmentation of the Tail in Appendicularia</i> .. .. .	442
CAULLERY— <i>Degeneration of Distaplia</i> .. .. .	442

##### b. Bryozoa.

VÁNGEL, E.— <i>Bryozoa of Hungary</i> .. .. .	442
---	-----

##### Arthropoda.

DANA, J. D.— <i>Derivation and Homologies of some Articulatæ</i> .. .. .	442
--	-----

	PAGE
<b>a. Insecta.</b>	
MALLOCK, A.— <i>Insect Sight and the Defining Power of Composite Eyes</i> .. .. .	443
DIXEY, F. A.— <i>Phylogeny of the Pierinae</i> .. .. .	443
CHAPMAN, T. A.— <i>Notes on Micro-Lepidoptera</i> .. .. .	443
FRITZE, A.— <i>Seasonal Dimorphism and Polymorphism in Japanese Butterflies</i> ..	444
KIRBY, W. F.— <i>Bees and Dead Carcasses</i> .. .. .	444
JANET, C.— <i>Glandular System of Ants</i> .. .. .	444
BORDAS— <i>Poison-Apparatus of Hymenoptera</i> .. .. .	445
„ <i>Salivary Glands of Ichneumonidæ</i> .. .. .	445
CUÉNOT, L.— <i>Defensive Ejection of Blood</i> .. .. .	446
VISART, O.— <i>Alimentary Canal of Orthoptera</i> .. .. .	445
MITFORD, C. B.— <i>Flight of Locusts</i> .. .. .	445
D'HERCULAIS, J. KÜNCKEL— <i>Dipterous Parasites of Locusts</i> .. .. .	446
NIETSCH, V.— <i>Tracheal System of Locusta</i> .. .. .	446
SCUDDER, S. H.— <i>Tertiary Tipulidæ</i> .. .. .	446
<b>B. Myriopoda.</b>	
UNDERWOOD, L. M.— <i>Myriopoda of North America</i> .. .. .	447
SCHMIDT, P.— <i>Structure of Pauropus</i> .. .. .	447
<b>δ. Arachnida.</b>	
BERNARD, H. M.— <i>Lateral Eyes in Galeodidæ</i> .. .. .	447
SCHIMKEWITSCH, W.— <i>Endosternite of Arachnida</i> .. .. .	448
TROUSSERT, E.— <i>Parthenogenesis of Sarcoptidæ</i> .. .. .	448
PATTEN, W.— <i>Structures resembling Dermal Bones in Limulus</i> .. .. .	448
<b>ε. Crustacea.</b>	
CUÉNOT, L.— <i>Physiology of Decapod Crustacea</i> .. .. .	449
BUMPUS, H. C.— <i>Median Eye of Adult Crustacea</i> .. .. .	449
THOMPSON, H.— <i>Correlation of certain External Parts of Palæmon serratus</i> ..	449
LÖNNBERG, E.— <i>Blind Cambarus from Florida</i> .. .. .	450
THOMPSON, I. C.— <i>Copepoda of Liverpool Bay</i> .. .. .	450
GRUVEL, A.— <i>Cirripedia</i> .. .. .	450
<b>Vermes.</b>	
<b>a. Annelida.</b>	
MCINTOSH, W. C.— <i>Structure of Euphrosyne</i> .. .. .	450
„ „ <i>Young Stages of Magelona</i> .. .. .	451
BÉRANECK, E.— <i>Auditory Organs of Alciopidæ</i> .. .. .	451
<b>β. Nemathelminthes.</b>	
COBB, N. A.— <i>New Genera of Nematodes</i> .. .. .	451
JÄGERSKIÖLD, L. A.— <i>Structure of Nematodes</i> .. .. .	452
LINSTOW, V.— <i>Heterakis Sinsinoi</i> .. .. .	452
GÖLDI, E.— <i>Nematode of Coffee-Disease</i> .. .. .	452
<b>γ. Platyhelminthes.</b>	
WHEELER, W. M.— <i>Planocera inquilina</i> .. .. .	452
„ „ <i>New Marine Triclad</i> .. .. .	453
GAMBLE, F. W.— <i>Turbellaria of Liverpool Marine District</i> .. .. .	454
BRAUN, M.— <i>Life-history of Holostomidæ</i> .. .. .	454
LINSTOW, V.— <i>Helminthological Notes</i> .. .. .	454
BRAUN, M.— <i>New Human Liver Fluke</i> .. .. .	454
KÜHLER, E.— <i>Valvular Apparatus in Excretory Vessels of Tænia</i> .. .. .	454
CHOLODKOVSKY, N.— <i>Tænia Brandti</i> .. .. .	455
HASWELL, W. A., & J. P. HILL— <i>Polycercus</i> .. .. .	455
<b>δ. Incertæ Sedis.</b>	
HILL, J. P.— <i>Balanoglossus from New South Wales</i> .. .. .	455
MASTERMAN, A. T.— <i>Food of Sagitta</i> .. .. .	456
WHEELER, W. M.— <i>Protrandric Hermaphroditism in Myzostoma</i> .. .. .	456
BILFINGER, L.— <i>Rotifera of Württemberg</i> .. .. .	456
<b>Echinoderma.</b>	
MÖRTENSEN, T.— <i>Anatomy and Development of Cucumaria glacialis</i> .. .. .	456
KISHINOUE, K.— <i>Development of a Holothurian Spicule</i> .. .. .	457
<b>Cœlentera.</b>	
KOCH, G. V.— <i>Asexual Reproduction of Madrepora</i> .. .. .	457
LACAZE-DUTHIERS, H. DE— <i>Flabellum anthophyllum</i> .. .. .	457



	PAGE
BOURNE, G. C.— <i>Post-embryonic Development of Fungia</i> .. .. .	458
WILLEM, V.— <i>Structure of Tentacles of Apolemia uvaria</i> .. .. .	459
DAVENPORT, C. B.— <i>Regeneration in Obelia</i> .. .. .	459
GÜNTHER, R. T.— <i>Limnocoñida tanqanyicæ</i> .. .. .	460
BEAUMONT, W. I.— <i>Lucernaria of Port Erin</i> .. .. .	460

#### Porifera.

MINCHIN, E. A.— <i>Embryology of Porifera</i> .. .. .	461
MASTERMAN, A. T.— <i>Nutritive and Excretory Processes in Porifera</i> .. .. .	461
DENDY, A.— <i>Comparative Anatomy of Sponges</i> .. .. .	461

#### Protozoa.

GREENWOOD, M., & SAUNDERS, E. R.— <i>Rôle of Acid in Protozoan Digestion</i> .. .. .	462
LEVANDER, K. M.— <i>Protozoa of Helsingfors</i> .. .. .	462
WASSILIEWSKI— <i>Protozoa in Herpes Zoster</i> .. .. .	462
ROOS, E.— <i>Infusoria of Diarrhœa</i> .. .. .	463
BLOCHMANN, F.— <i>Dimorpha mutans</i> .. .. .	463
GOULD, L. J.— <i>Minute Structure of Pelomyxa palustris</i> .. .. .	463
ISHIKAWA, C.— <i>Nuclear Division in Noctiluca</i> .. .. .	464
RHUMBLER, L.— <i>Enclosure of Globigerina by Orbulina</i> .. .. .	464
GURLEY, R. R.— <i>Classification of Myxosporidia</i> .. .. .	465
THÉLOHAN, P.— <i>Spores of Microsporidia</i> .. .. .	465
LÉGER, L.— <i>New Genus of Gregarines</i> .. .. .	466
SAKHAROFF— <i>Structure of Nucleus of Crescentiform Bodies of Malaria</i> .. .. .	466

### BOTANY.

#### A. GENERAL, including the Anatomy and Physiology of the Phanerogamia.

##### a. Anatomy.

##### (1) Cell-structure and Protoplasm.

DEMOOR, J.— <i>Independence of the Nucleus and the Cytoplasm</i> .. .. .	467
ELLIOTT, L. B.— <i>Karyokinesis</i> .. .. .	467
MANGIN, L.— <i>Structure of the Cell-wall</i> .. .. .	467
ZIMMERMANN, A.— <i>Growth of the Cell-wall</i> .. .. .	467
RACIBORSKI, M.— <i>Development of Elaioplasts in the Liliacæ</i> .. .. .	467
ZIMMERMANN, A.— <i>Proteinaceous Crystalloids</i> .. .. .	468

##### (2) Other Cell-contents (including Secretions).

MESNARD, E.— <i>Localization of Fatty Oils in the Formation of Seeds and Fruits</i> .. .. .	468
GUIGNARD, L.— <i>Active Principles of the Papayacæ</i> .. .. .	468
MOLISCH, H.— <i>Indican</i> .. .. .	469
KRISTELLI, SCHRÖTTER v.— <i>Pigment of the Aril</i> .. .. .	469
DEMOUSSY— <i>Nitrates in Living Plants</i> .. .. .	469

##### (3) Structure of Tissues.

SONNTAG, P.— <i>Connection between Lignification, Firmness, and Elasticity in Cell-walls</i> .. .. .	469
PETERSEN, O. G.— <i>Increase in Thickness of the Stem of Monocotyledons</i> .. .. .	469
LESAGE, P.— <i>Palisade-cells and Transpiration</i> .. .. .	470
HERBST, A.— <i>Medullary Rays of Dicotyledonous Herbs and Shrubs</i> .. .. .	470
MER, E.— <i>Witch-broom of the Fir</i> .. .. .	470
AVETTA, C.— <i>Cystoliths of Coccinia</i> .. .. .	471
SOLEREDER, H.— <i>Anatomy of Rubiacæ</i> .. .. .	471

##### (4) Structure of Organs.

CHATIN, A.— <i>Variety and Localisation of Organs as Evidence of Gradation</i> .. .. .	471
SCHENCK, H.— <i>Young Form of Gymnosperms</i> .. .. .	471
GOLENKIN, M.— <i>Inflorescence of Urticacæ and Moracæ</i> .. .. .	472
KLEIN, J.— <i>Structure of the Flower of Cruciferæ</i> .. .. .	472
SCHUMANN, K.— <i>Development of the Flowers of Crocus</i> .. .. .	472
ČELAKOVSKÝ, L.— <i>Cladodes of the Asparagæz</i> .. .. .	472
MEISSNER, R.— <i>Size of the Leaves of Conifers</i> .. .. .	472
TONKOFF, W.— <i>Swellings on the Leaf-stalk of Atragene</i> .. .. .	473
MEINECKE, E. P.— <i>Aerial Roots of Orchidæz</i> .. .. .	473
TIEGHEM, P. VAN— <i>Root of Parasitic Lorantheacæz</i> .. .. .	473

##### B. Physiology.

##### (1) Reproduction and Embryology.

RACIBORSKI, M.— <i>Chromatophily of the Nuclei of the Embryo-sac</i> .. .. .	473
MOLISCH, H.— <i>Physiology of Pollen</i> .. .. .	474



DIXON, H. H.— <i>Fertilization of Pinus</i> .. .. .	474
PAMMEL, L. H.— <i>Hybridism in Cucurbitaceæ</i> .. .. .	475
WAGNER, A.— <i>Pollination of Strelitzia</i> .. .. .	475

(2) Nutrition and Growth (including Germination, and Movements of Fluids).

WIESNER, J.— <i>Influence of the Chemical Intensity of Light on the Growth of Plants</i> .. .. .	475
NOLL, F.— <i>Influence of Phosphorus on the Growth of Plants</i> .. .. .	476
DANIEL, L.— <i>Morphology and Physiology of Grafting</i> .. .. .	476
ROMANES, G. J., & OTHERS— <i>Germination of Seeds</i> .. .. .	476
POTONIÉ, H.— <i>Pseudo-vivipary of Juncus bufonius</i> .. .. .	477
AMELUNG, E.— <i>Etiolation</i> .. .. .	477
VUILLEMIN, P., & E. LEGRAIN— <i>Symbiosis of Heterodera radiciicola with Plants cultivated in the Sahara</i> .. .. .	477
SCHNEIDER, A.— <i>Symbiosis of Algæ and Bacteria with Cycas</i> .. .. .	478
GUÉRIN, C.— <i>Life-history of the Mistletoe</i> .. .. .	478
BRÉAL, E., & OTHERS— <i>Assimilation of Nitrogen by Plants</i> .. .. .	478
NOBBE, F., & L. HILTNER— <i>Fixation of Free Nitrogen by the Leguminosæ</i> .. .. .	479

(3) Irritability.

ELFVING, F.— <i>Irritability in Plants</i> .. .. .	479
MIYOSHI, M.— <i>Chemotropic Movements</i> .. .. .	479
ROMANES, G. J.— <i>Heliotropism</i> .. .. .	480
FIGDOR, W.— <i>Heliotropic Sensitiveness</i> .. .. .	480
PEIRCE, G. J.— <i>Biology of Cuscuta</i> .. .. .	480

(4) Chemical Changes (including Respiration and Fermentation).

DUCLAUX, E.— <i>Analogies between Fermentation and Solar Combustion</i> .. .. .	481
---	-----

γ. General.

MACMILLAN, C.— <i>Archenema, Protonema, and Metanema</i> .. .. .	481
--	-----

B. CRYPTOGRAMIA.

Cryptogamia Vascularia.

PRANTL, K.— <i>Classification of Ferns</i> .. .. .	481
CAMPBELL, D. H.— <i>Development of Marattia</i> .. .. .	481

Muscineæ.

STEPHANI, F., & J. B. JACK— <i>New Genera of Hepaticæ</i> .. .. .	482
FARMER, J. B.— <i>Pallavicinia decipiens</i> .. .. .	483

Algæ.

HANSEN, A.— <i>Metastasis in Marine Algæ</i> .. .. .	483
AGARDH, J. G.— <i>New Genera of Algæ</i> .. .. .	483
ASKENASY, E.— <i>Australian Marine Algæ</i> .. .. .	483
DARBISHIRE, O. V.— <i>Phyllophora</i> .. .. .	484
KJELLMAN, F. R.— <i>Laminaria</i> .. .. .	484
LÜTKEMÜLLER, J.— <i>Pores of Desmidiaceæ</i> .. .. .	484
KJELLMAN, F. R.— <i>Acrosiphonia</i> .. .. .	484
SCHMIDLE, W.— <i>Radiofilum, a new Genus of Chlorophyceæ</i> .. .. .	485
KLEMM, P.— <i>Rejuvenescence in the Siphonææ</i> .. .. .	485

Fungi.

DANGEARD, P. A., & LÉGER— <i>Sexual Reproduction in Fungi</i> .. .. .	485
VUILLEMIN, P.— <i>Insertion of Spores and Direction of the Septa in Protobasids</i> .. .. .	486
THAXTER, R.— <i>Sapromyces (Naegelia)</i> .. .. .	486
DANGEARD, P. A., & LÉGER— <i>Nuclei of the Mucorini</i> .. .. .	486
DANGEARD, P. A.— <i>Structure of the Ustilagineæ</i> .. .. .	487
VUILLEMIN, P.— <i>Ustilago producing Woody Tumours</i> .. .. .	487
SADEBECK, R.— <i>Ezoasceæ</i> .. .. .	487
DANGEARD, P. A.— <i>Structure of Lichens</i> .. .. .	487
PATERNÒ, E., & F. CROSA— <i>New Substance extracted from Lichens</i> .. .. .	488
CROMBIE'S <i>British Lichens</i> .. .. .	488
KANTHACK, A. A.— <i>Recent Researches on Saccharomycetes</i> .. .. .	488
DELACROIX, G., & OTHERS— <i>Parasitic Fungi</i> .. .. .	488
POIRAULT, G.— <i>Uredineæ and their Hosts</i> .. .. .	489
DIETEL, P.— <i>Ravenelia</i> .. .. .	490
BRUNS, E.— <i>Polysaccum</i> .. .. .	490
SCHNEIDER, A.— <i>Rhizobes</i> .. .. .	490

Mycetozoa.

McBRIDE, T. H., & E. J. DURAND— <i>New Myzomycetes</i> .. .. .	490
HALSTED, B. D.— <i>Plasmiodiophora Brassicæ</i> .. .. .	490

## Protophyta.

	PAGE
<b>a. Schizophyceæ.</b>	
DAVIS, B. M.— <i>Cryptoglena americana</i> sp. n. . . . .	490
HÉRIBAUD, J.— <i>Influence of Light and of Altitude on the Striation of Diatoms</i> . . . . .	491
<b>B. Schizomycetes.</b>	
BABES, O.— <i>The State and Modern Bacteriological Research</i> . . . . .	491
KLEIN, E.— <i>Morphology of Bacteria</i> . . . . .	491
PRILLIEUX, E., & G. DELACROIX— <i>Bacillar Diseases of Plants</i> . . . . .	492
ZELINSKY, N.— <i>Microbes which evolve Hydrogen Sulphide</i> . . . . .	492
KHMELEVSKY, P. A.— <i>Influence of Light on Pyogenic Microbes</i> . . . . .	492
DENYS, J., & J. HAVET— <i>Leucocytes and Bactericidal Power</i> . . . . .	492
SCHOLL, H.— <i>Bactericidal Properties of Potash-Albumen</i> . . . . .	493
SANFELICE— <i>Anaerobic Micro-organisms</i> . . . . .	493
KUPRIANOW, J.— <i>Vibrios and the Production of Lactic Acid</i> . . . . .	494
MIQUEL, P.— <i>Duration of Incubation of Air and Water Micro-organisms on Gelatin</i> . . . . .	494
MÜHSAM, R., & C. SCHIMMELBUSCH— <i>Pigment production of Bacillus pyocyaneus in Symbiosis with other Organisms</i> . . . . .	495
TRAMBUSTI, A.— <i>Physiological Effect of Metabolic Products of B. Hydrophilus fuscus</i> . . . . .	495
KLEIN, E.— <i>Intracellular Bacterial Poisons</i> . . . . .	495
KLECKI, V. VON— <i>Micro-organisms of Rancid Butter</i> . . . . .	496
PASQUALE, A.— <i>Streptococci</i> . . . . .	497
DORNBERGER— <i>Streptococci in the Healthy and Unhealthy Mouth</i> . . . . .	498
CHATIN, P.— <i>Atmospheric Streptococci</i> . . . . .	498
CELLI, A., & S. SANTORI— <i>Transitory Variety of the Cholera Vibrio</i> . . . . .	498
IWÁNOFF, M.— <i>New Species of Choleroïd Vibrio</i> . . . . .	498
WERNICKE— <i>Cholera Bacillus and Tobacco</i> . . . . .	499
METCHNIKOFF, E.— <i>Artificial Variation of the Cholera Vibrio</i> . . . . .	499
STOECKLIN, H. DE— <i>Coli Group of Bacteria</i> . . . . .	499
SITTMANN & BARNOW— <i>Bacterium coli commune in Living Blood</i> . . . . .	500
BRUCE, D.— <i>Ætiology of Malta Fever</i> . . . . .	500
LEHMANN, K. B.— <i>Bacillus levans</i> . . . . .	500
LOEWENBERG— <i>Microbe of Ozæna</i> . . . . .	501
WERIGO— <i>Anthrax in the Rabbit, and its Lessons</i> . . . . .	501
DAWSON, W. R.— <i>Manual of Bacteriology</i> . . . . .	502
FISCHER, B.— <i>Bacteriology of the Plankton Expedition</i> . . . . .	502
BIBLIOGRAPHY . . . . .	503

## MICROSCOPY.

### a. Instruments, Accessories, &c.

BIBLIOGRAPHY . . . . .	506
(1) Stands.	
SWIFT'S <i>Four-legged Microscope</i> (Figs. 37 and 38) . . . . .	506
ROSS & Co.'s " <i>Eclipse</i> " <i>Microscope</i> (Figs. 39 and 40) . . . . .	507
SWIFT'S <i>new Mechanical Stage</i> (Fig. 41) . . . . .	509
(2) Eye-pieces and Objectives.	
STEINHEIL, R.— <i>New Objective Setting</i> (Figs. 42 and 43) . . . . .	509
(3) Illuminating and other Apparatus.	
HEARSON'S <i>Biological Gas Incubator</i> (Figs. 44 and 45) . . . . .	511
" <i>Biological Incubator working with a Petroleum Lamp</i> (Fig. 46) . . . . .	513
" <i>Patent Cool Biological Incubator for Gelatin Cultures</i> (Fig. 47) . . . . .	514
REICHENBACH, H.— <i>Incubator for any Source of Heat</i> . . . . .	516
(4) Photomicrography.	
CURTIES, C. LEES— <i>Apparatus for Obtaining Instantaneous Photomicrographs</i> (Fig. 48) . . . . .	516
BAKER'S <i>Photographic Microscope</i> (Fig. 49) . . . . .	517
LEMARDELEY'S <i>Photographic Microscope</i> . . . . .	518
(5) Microscopical Optics and Manipulation.	
PIFFARD— <i>A Suggested Method of Increasing the N.A. of Old Achromatic Object-glasses</i> . . . . .	518
HOULBERT, C.— <i>Researches on the Optical Properties of Wood</i> (Figs. 50-54) . . . . .	519
(6) Miscellaneous.	
GILTAY'S (E.) <i>Introduction to the Study of Microscopy</i> . . . . .	522
BEHRENS' (H.) <i>Micro-Chemistry</i> . . . . .	522
A LITTLE <i>Diversion</i> . . . . .	523



## s. Technique.

PAGE

HUMPHREY, J. E.— <i>Zimmermann's Botanical Micro-technique</i> .. .. .	523
MILLER— <i>Short Notes on Bacteriological Technique</i> .. .. .	524
ACOSTA & GRANDE ROSSI— <i>Bacteriological Technique</i> .. .. .	524

## (1) Collecting Objects, including Culture Processes.

SMITH, J. LORRAIN— <i>New Method of Preparing Culture Media</i> .. .. .	524
MAASEN, A.— <i>Non-albuminous Cultivation Media for Vibrios</i> .. .. .	525
INGHILLERI— <i>The Bujwid Reaction and Bouillon Cultivations</i> .. .. .	525
HUBER— <i>Cultivating Influenza Bacillus</i> .. .. .	526
BOYCE, R., & A. E. EVANS— <i>Growing and Examining Bacterium Zopfii</i> .. .. .	526
ZENTHÖFER— <i>Cultivating Cholera on Eggs</i> .. .. .	526
ELSNER— <i>Plate Diagnosis of Cholera</i> .. .. .	526
DROSSBACH, G. P.— <i>Examining Water for Anaerobic Bacteria</i> .. .. .	527
SIRENA, S., & G. SCAGLIOSI— <i>Experiments as to Vitality of Anthrax Spores in Earth and Water</i> .. .. .	527
CAZENEUVE & ET. & N. RODET— <i>Microbicidal Action of Gallanol</i> .. .. .	527
WALLICZEK, H.— <i>Testing Resistance of Bacterium coli commune to Drying</i> .. .. .	528
KRUSE, W.— <i>Method for Inoculating Gelatin Plates</i> .. .. .	528
WALLICZEK, H.— <i>Technique of Disinfection Experiments</i> .. .. .	528
MIE, G.— <i>Modification of Wölffhügel's Colony Counter</i> .. .. .	529
KÖRBER, B.— <i>Distribution of Bacteria Colonies in Esmarch's Roll Tubes</i> .. .. .	529
MALLY, F. W.— <i>Combination Hot Filter and Steam Sterilizer</i> .. .. .	529
LACOUR-EYMARD— <i>Chamberland Filter Système André</i> .. .. .	529
UNNA, P. G.— <i>Natural Pure Cultivations of Skin Fungi</i> .. .. .	530
ORŁOWSKI— <i>Demonstrating Sulphuretted Hydrogen generated by Bacteria</i> .. .. .	530

## (2) Preparing Objects.

WASHBURN, F. L.— <i>Examination of Eggs of Limax maximus</i> .. .. .	531
SAMASSA, P.— <i>Examination of Tentacular Nerves of Helix pomatia</i> .. .. .	531
KRÜCKMANN, C.— <i>Making and Preserving Specimens of Bacteria for Museum Purposes</i> .. .. .	531
PINTNER, TH.— <i>Preservation of Marine Animals in Formaldehyde</i> .. .. .	532

## (3) Cutting, including Imbedding and Microtomes.

PATTEN, W.— <i>Orienting Small Objects for Sectioning</i> .. .. .	532
<i>New Machine for Cutting Thin Sections of Rocks and Minerals</i> .. .. .	533

## (4) Staining and Injecting.

ANDRIEZEN, W. L.— <i>Modification of Golgi's Method for Study of Human Brain</i> .. .. .	533
LEMAIRE, A.— <i>Two new Staining-reagents for Meristems</i> .. .. .	533
SCHMIDT, A.— <i>Staining Reactions of Sputum</i> .. .. .	534
LANZ— <i>New Procedure for Staining Gonococcus</i> .. .. .	534
CARAZZI, D.— <i>Bleaching Animals and Sections fixed with Osmic Mixtures</i> .. .. .	534

## (5) Mounting, including Slides, Preservative Fluids, &amp;c.

PATTEN, W.— <i>Mounting Small Objects in Cells</i> .. .. .	534
ZETTNOW— <i>Cleaning Dirty Slides and Cover-glasses</i> .. .. .	535

## (6) Miscellaneous.

DENYS, J.— <i>Diagnosis of Cholera by the Microscope</i> .. .. .	535
--	-----

## PROCEEDINGS OF THE SOCIETY:—

Meeting, 20th June, 1894 .. .. .	536
----------------------------------	-----

Authors of Papers printed in the Transactions are entitled to 20 copies of their communications *gratis*. Extra copies can be had at the price of 10s. 6d. per half-sheet of 8 pages, or less, including cover, for a minimum number of 50 copies, and 6s. per 100 plates, if plain. Prepayment by P.O.O. is requested.

# R. & J. BECK'S MICROSCOPES

FIRST CLASS

OBJECT  
GLASSES.

—  
MICROTOMES

—  
LAMPS.

—  
OBJECTS.

—  
CABINETS.

—  
APPARATUS.

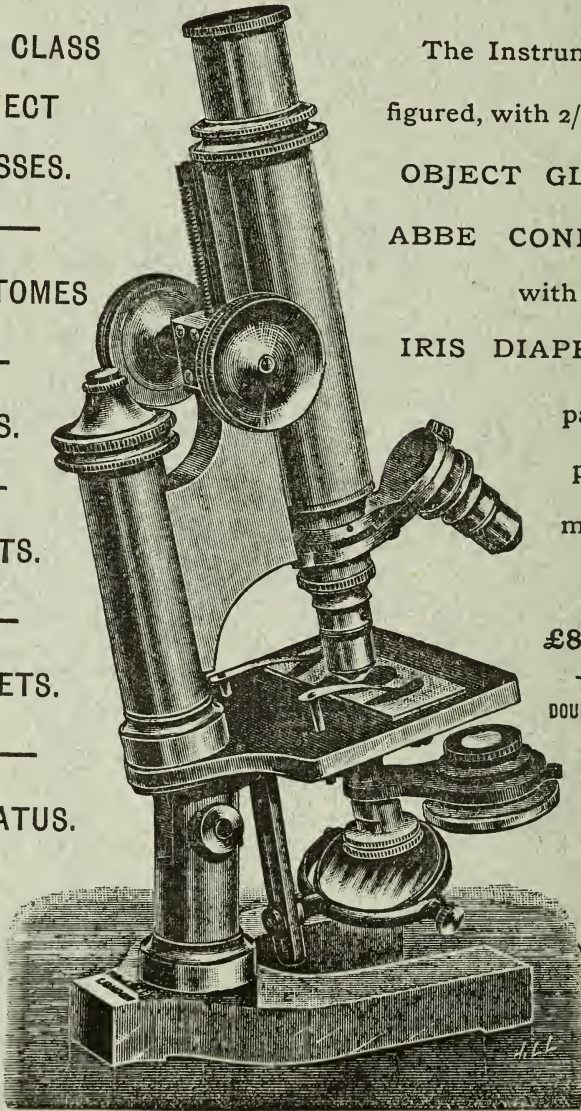

The Instrument as  
figured, with  $\frac{2}{3}$  &  $\frac{1}{6}$  in.  
OBJECT GLASSES,  
ABBE CONDENSER  
with

IRIS DIAPHRAGM,

packed in  
polished  
mahogany  
case,

£8 15s. 0d.

—  
DOUBLE NOSEPIECE  
16s. 6d.

EXTRA.

No. 29.—New Form CONTINENTAL MODEL MICROSCOPE.

FULL ILLUSTRATED DESCRIPTIVE CATALOGUE FREE ON APPLICATION.

**R. & J. BECK, 68 CORNHILL, LONDON, E.C.**

FACTORY: LISTER WORKS, KENTISH TOWN, N.W.



The Journal is issued on the third Wednesday in  
February, April, June, August, October, and December.

1894. Part 6.

DECEMBER.

{ To Non-Fellows,  
Price 6s.

JOURNAL

OF THE

ROYAL

MICROSCOPICAL SOCIETY;

CONTAINING ITS TRANSACTIONS AND PROCEEDINGS,

AND A SUMMARY OF CURRENT RESEARCHES RELATING TO

ZOOLOGY AND BOTANY

(principally Invertebrata and Cryptogamia),

MICROSCOPY, &c.

*Edited by*

**F. JEFFREY BELL, M.A.,**

*One of the Secretaries of the Society*

*and Professor of Comparative Anatomy and Zoology in King's College;*

WITH THE ASSISTANCE OF THE PUBLICATION COMMITTEE AND

**A. W. BENNETT, M.A., B.Sc., F.L.S.,**

*Lecturer on Botany at St. Thomas's Hospital,*

**R. G. HEBB, M.A., M.D. (Cantab.),** AND

**J. ARTHUR THOMSON, M.A.,**

*Lecturer on Zoology in the School of Medicine,*

*Edinburgh,*

FELLOWS OF THE SOCIETY.



LONDON:

TO BE OBTAINED AT THE SOCIETY'S ROOMS,

20 HANOVER SQUARE, W.;

OF MESSRS. WILLIAMS & NORGATE; AND OF MESSRS. DULAU & CO.

# CONTENTS.

## TRANSACTIONS OF THE SOCIETY—

	PAGE
IX.—THE FORAMINIFERA OF THE GAULT OF FOLKESTONE.—VII. By Frederick Chapman, F.R.M.S. (Plates IX. and X.)..	645
X.—ON A SIMPLE METHOD OF MEASURING THE REFRACTIVE INDICES OF MOUNTING AND IMMERSION MEDIA. By Edward M. Nelson, F.R.M.S. . . . . .	655

### SUMMARY OF CURRENT RESEARCHES.

#### ZOOLOGY.

#### A. VERTEBRATA:—Embryology, Histology, and General.

##### a. Embryology.

GIACOMINI, C.— <i>An Abnormal Human Embryo</i> . . . . .	661
KLAATSCH, H.— <i>Origin of the Scleroblasts</i> . . . . .	661
GEGENBAUR, C.— <i>Phylogeny of the Tongue</i> . . . . .	662
HOCHSTETTER, F.— <i>Development of Venous System of Mammals</i> ..	662
HIROTA, S.— <i>Sero-Amniotic Connection and Fetal Membranes of Chick</i> . . . . .	663
MITSUKURI, K.— <i>Gastrulation in Chelonia</i> . . . . .	664
LANGER, A.— <i>Development of Bulbus Cordis in Amphibians and Reptiles</i> . . . . .	664
HOCHSTETTER, F.— <i>Development of Abdominal Vein in Amphibia</i> . . . . .	665
LUNDBORG, H.— <i>Development of Hypophysis and Saccus vasculosus in Teleostei and Amphibia</i> . . . . .	665
HOLM, J. F.— <i>Development of Olfactory Organ in Teleostei</i> ..	665
M'INTOSH, W. C.— <i>Ova and Larvæ of British Fishes</i> . . . . .	665

##### b. Histology.

MOORE, J. E. S.— <i>Archoplasm and Attraction Sphere</i> . . . . .	666
CHITTENDEN, R. H.— <i>Chemical Physiology of the Cell</i> . . . . .	666

##### γ. General.

BETHE, A.— <i>Function of Equilibration</i> . . . . .	666
RYDER, J. A.— <i>Correlations of the Volumes and Surfaces of Organisms</i> . . . . .	667

#### B. INVERTEBRATA.

STILES, C. W., & A. HASSALL— <i>Catalogue of Parasites</i> . . . . .	667
COUPIN, H.— <i>Food of two Commensals</i> . . . . .	667

##### Mollusca.

SMITH, E. A.— <i>Indian Deep-Sea Mollusca</i> . . . . .	668
---	-----

##### γ. Gastropoda.

SCHMIDT, F.— <i>Cleavage and Germ-Layer Formation in Stylommatophora</i> . . . . .	668
LACAZE-DUTHIERS— <i>Gonads of Ancyclus</i> . . . . .	668
GILCHRIST, J. D. F.— <i>Arrangement, Correlation, and Function of Pallial Organs of Tectibranchiata</i> . . . . .	669
CRAMPTON, H. E.— <i>Reversal of Cleavage in a Sinistral Gastropod</i> . . . . .	669
VABIGNY, H. DE— <i>Experimental Nanism</i> . . . . .	670
CUÉNOT, L.— <i>Function of Kidney of Helix</i> . . . . .	670
PELSENEER, P.— <i>Branchiate Pulmonates</i> ..	670
HALLER, B.— <i>Notes on Polyplacophora</i> . . . . .	670

##### δ. Lamellibranchiata.

KISHINOUE, K.— <i>Eyes of Cardium muticum</i> ..	671
--	-----

##### Molluscoidea.

##### a. Tunicata.

CAULLERY, M.— <i>Budding of Diplosomidæ and Didemnidæ</i> . . . . .	671
GOTTSCHALDT, R.— <i>Synascididæ of Spitzbergen Expedition</i> . . . . .	671
RITTER, W. E.— <i>Perophora annexus</i> . . . . .	672

## Arthropoda.

	PAGE
WAGNER, J.— <i>Germinal Layers, Yolk Cells, and Embryonic Membranes of Arthropoda</i>	672

## a. Insecta.

MERRIFIELD, F., & F. A. DIXEY— <i>Temperature Experiments on Lepidoptera</i>	673
VERHOEFF, C.— <i>Comparative Morphology of Abdomen of Lampyridæ, Cantharidæ and Malachiidæ</i>	673
CAMERANO, L.— <i>Absolute Force of Muscles</i>	673
ESCHERICH, K.— <i>Male Reproductive Organs of Beetles</i>	673
SCUDDER, S. H.— <i>Tertiary Rhynchophorous Coleoptera of the United States</i>	674
MARCHAL, P.— <i>Seminal Receptacle of the Wasp</i>	674
"    " <i>Fertile Workers among Bees</i>	674
"    " <i>Diptera destructive of Cereals</i>	675
DREYFUS, L.— <i>Anatomy of Phylloxeridæ</i>	675
KÖNIG, A.— <i>Larva of Oncodes</i>	675
KOWALEVSKY, A.— <i>Heart of Orthoptera</i>	675

## β. Myriopodæ.

VERHOEFF, C.— <i>Classification of Iulidæ</i>	675
DUBOSCQ, O.— <i>Poison-Glands of Chilopoda</i>	676

## δ. Arachnida.

SIMMONS, O. L.— <i>Development of Lungs of Spiders</i>	676
KISHINOUE, K.— <i>Celomic Cavity of Spider</i>	676
BRAUER, A.— <i>Development of Scorpion</i>	677
TROUSSART, E.— <i>Parthenogenesis in Plumicolous Sarcoptidæ</i>	677

## ε. Crustacea.

PHILIPPI, R. A.— <i>European and Chilian Crustacea</i>	677
HERRICK, F. H.— <i>Reproduction of Lobster</i>	677
BOUVIER, E. L.— <i>Conversion of Pagurinae into Lithodinae</i>	678
CHILTON, C.— <i>Subterranean Crustacea of New Zealand</i>	678
ORTMANN, A.— <i>Pelagic Schizopoda</i>	679
SARS, G. O.— <i>Caspian Crustacea</i>	679
SCOTT, T.— <i>Entomostraca from Gulf of Guinea</i>	680
MÜLLER, G. W.— <i>Ostracoda of Naples</i>	680
CLAUS, C.— <i>Metamorphosis of Freshwater Ostracoda</i>	681
ASTROUMOFF, A.— <i>A Flying Copepod</i>	681

## Vermes.

LOEB, J.— <i>Cerebral Physiology of Worms</i>	681
---	-----

## a. Annelidæ.

ST. JOSEPH, DE— <i>Polychæta of Dinard</i>	682
HESSE, R.— <i>Septal Glands of Oligochæta</i>	682
BEDDARD, F. E.— <i>New or Little-known Oligochæta</i>	683
ROSA, D.— <i>Revision of Lumbricidæ</i>	683
MERRILL, H. B.— <i>Eye of Leech</i>	683
BOLSUS, H.— <i>Efferent Canal of Glossiphoniidæ</i>	683
FISCHER, W.— <i>Gill-like Organs of Sipunculus</i>	683

## β. Nemathelminthes.

VEJDOVSKÝ, F.— <i>Development of Organs in Gordiidæ</i>	684
GILSON, G., & J. PANTEL— <i>Muscular Cells of Ascaris</i>	685
MUELLER, A.— <i>Helminthological Notes</i>	685

## γ. Platyhelminthes.

KELLER, J.— <i>Asexual Reproduction in Freshwater Turbellaria</i>	685
GRAFF, L.— <i>Notes on Land Planarians</i>	686
PLATE, L.— <i>Temnnocephala chilensis</i>	686
LOOSS, A.— <i>Monograph on Distomum</i>	687
IJIJMA, I., & T. KURIMOTO— <i>New Human Tape-worm</i>	687
LUTZ, A.— <i>Tænia nana and flavopunctata</i>	687
PERRONCITO, E.— <i>Growth of Tænia mediocanellata</i>	688



## Echinoderma.

	PAGE
BELL, F. JEFFREY— <i>Echinoderms of Eastern Seas</i> .. .. .	688
ALCOCK, A.— <i>Illustrations of Indian Echinoderms</i> .. .. .	689
LUDWIG, H.— <i>Asteroida</i> .. .. .	689
CLARK, W. B.— <i>Mesozoic Echinoderma of the United States</i> .. .. .	689

## Cœlentera.

HICKSON, S. J.— <i>Revision of Aleyonaria Stolonifera</i> .. .. .	690
BOURNE, G. C.— <i>Helipora cærulea</i> .. .. .	690
PHILIPPI, R. A.— <i>Callirhabdos</i> .. .. .	691
LANG, A.— <i>Budding of Hydroids</i> .. .. .	691

## Porifera.

VOSMAER, G. C. J.— <i>Tetractinellidæ of Naples</i> .. .. .	691
IJIMA, I.— <i>New Hexactinellids from Sagami Bay</i> .. .. .	691

## Protozoa.

PRZESMYCKI, M.— <i>Cell-granules in Protozoa</i> .. .. .	691
RITTER, W. E.— <i>Parasite of Perophora annectens</i> .. .. .	692
LINDNER— <i>Morbific Effect of certain Vorticellæ</i> .. .. .	692
RYDER, J. A.— <i>Growth of Euglena confined to two dimensions of space</i> .. .. .	692
ISHIKAWA, C.— <i>Reproduction of Noctiluca miliaris</i> .. .. .	693
CELLI, A., & R. FIOCCA— <i>Classification of Amœbæ</i> .. .. .	694
” ” <i>The Life of Amœbæ</i> .. .. .	694
LISTER, J.— <i>Life-history of Foraminifera</i> .. .. .	694
RHUMBLER, L., & W. ZOPF— <i>Saccammina</i> .. .. .	695
LABBÉ, A.— <i>Double Coccidian Infection</i> .. .. .	696
ROOS & QUINCKE— <i>Amœba-Enteritis</i> .. .. .	696
DORIA, T. R.— <i>Protozoa in Endometritis</i> .. .. .	696
MARCHAND, F., & K. MIURA— <i>Trichomonas in Urine of Men</i> .. .. .	697
RUFFER, M. A., & OTHERS— <i>Parasite of Vaccinia and Variola</i> .. .. .	697
GUEYNATZ & PETROFF— <i>Parasites of Sarcoma</i> .. .. .	698
FOÀ, P., & OTHERS— <i>Parasites of Cancer</i> .. .. .	698
NITSCH, P., & W. WELTNER— <i>Tetramitus Nitschei, a Parasite of Goldfish</i> .. .. .	699
BASTIANELLI & BIGNAMI— <i>Structure of the Malaria Parasites of the Summer and Autumn Fevers</i> .. .. .	700
GRIMM— <i>Protozoa in Abscess of Lung and Liver</i> .. .. .	700

## BOTANY.

A. GENERAL, including the Anatomy and Physiology  
of the Phanerogamia.

## a. Anatomy.

## (1) Cell-structure and Protoplasm.

ZIMMERMANN, A.— <i>Eye-spot</i> .. .. .	701
” ” <i>Cilia and Pseudo-cilia</i> .. .. .	701
DANGEARD, P. Å., & LÉGER— <i>Structure of the Nucleus in Mucorini</i> .. .. .	701

## (2) Other Cell-contents (including Secretions).

MONTEVERDE, N.— <i>Absorption-spectrum of Chlorophyll</i> .. .. .	701
SCHUNCK, E.— <i>Chemistry of Chlorophyll</i> .. .. .	702
ÉTARD, A.— <i>Occurrence of several Chlorophylls in the same Plant</i> .. .. .	702
MESNARD, E.— <i>Formation and Localization of Fatty and Essential Oils</i> .. .. .	702
CHAUTRIAU, G.— <i>Localization of Alkaloids</i> .. .. .	703
MIELKE, G.— <i>Formation and Function of Tannins</i> .. .. .	703
ZIMMERMANN, A.— <i>Elaïoplasts and Elaïospheres</i> .. .. .	704
RE, L.— <i>Sphero-crystals of Agave</i> .. .. .	704
NEUMEISTER, R.— <i>Proteolytic Ferments in Seedlings</i> .. .. .	704
BELZUNG, E.— <i>Calcium Oxalate in Solution</i> .. .. .	704

## (3) Structure of Tissues.

JAHN, E.— <i>Wood and Pith at the bounds of Annual Growth</i> .. .. .	704
MICHEELS, H.— <i>Fruit-bearing Axis of Palms</i> .. .. .	705
ROULET, C.— <i>Anatomy of the Stem of Thunbergia</i> .. .. .	705

## (4) Structure of Organs.

JOLY, J.— <i>Bright Colour of Alpine Flowers</i> .. .. .	705
GROOM, P.— <i>Extra-floral Nectaries of Aleurites</i> .. .. .	705
HENSLOW, G.— <i>Self-adaptation of Plants to their Environment</i> .. .. .	705



	PAGE
JUNGNER, J. R.— <i>Adaptation of Fruits to Climate</i> .. .. .	706
OSENBRUG— <i>Rumination of the Seeds of Arca Catechu</i> .. .. .	706
WEISSE, A.— <i>Mechanical Theory of Phyllotaxis</i> .. .. .	706
CELAKOVSKY, L. J.— <i>Double Leaves of the Honeysuckle</i> .. .. .	706
BOLLEY, H. L.— <i>Root-tubercles of Leguminosæ</i> .. .. .	707
LECOMTE, H.— <i>Root-tubercles of Arachis</i> .. .. .	707
JAMIESON, T.— <i>Root-hairs</i> .. .. .	707

### β. Physiology.

#### (1) Reproduction and Embryology.

BENSON, M., & S. NAWASCHIN— <i>Embryology of the Amentiferæ</i> .. .. .	707
JACCARD, P.— <i>Embryology of Ephedra</i> .. .. .	708
GRAEBNER, P.— <i>Occasional Cleistogamy</i> .. .. .	709
GIBELLI, G., & OTHERS— <i>Cross- and Self-pollination</i> .. .. .	709
BEHRENS, J.— <i>Pollination of the Hop</i> .. .. .	710
WAITE, M. B.— <i>Pollination of the Pear</i> .. .. .	710

#### (2) Nutrition and Growth (including Germination, and Movements of Fluids).

STAHL, E., & R. MEISSNER— <i>Transpiration and Assimilation</i> .. .. .	710
BONNIER, G.— <i>Nutrition of Green Parasites</i> .. .. .	711
NEWCOMBE, F. C.— <i>Influence of Mechanical Resistance on the Development of Cells</i> ..	711
SCHLÆSING, T.— <i>Exchange of Carbon Dioxide and Oxygen</i> .. .. .	711
LECOMTE, H.— <i>Amount of Water absorbed by Roots</i> .. .. .	711

#### (3) Irritability.

JUEL, O.— <i>Mechanism of the Flowers of Schizanthus</i> .. .. .	712
CHAUVEAUD, G.— <i>Movements of the Stamens of Berberis</i> .. .. .	712
WRIGHT, S. G.— <i>Leaf-movement in Cercis</i> .. .. .	712
MEEHAN, T., & J. C. BAY— <i>Compass Plants</i> .. .. .	712

#### (4) Chemical Changes (including Respiration and Fermentation).

MARCACCI, A.— <i>Formation and Transformation of Carbohydrates</i> .. .. .	713
SCHLEICHERT, F.— <i>Diastatic Ferment</i> .. .. .	713
AEREBOE, F.— <i>Influence of Light on Respiration</i> .. .. .	713
MAYER— <i>Respiration of Plants in the Shade</i> .. .. .	713
CHUDIAKOW, N. V.— <i>Intramolecular Respiration</i> .. .. .	713

### γ. General.

GADEAU DE KERVILLE, H.— <i>Luminous Plants</i> .. .. .	714
BOKORNY, T.— <i>Purification of Streams by Chlorophyllous Plants</i> .. .. .	714
DUCLAUX— <i>Spontaneous Purification of River Water</i> .. .. .	714

## B. CRYPTOGAMIA.

### Cryptogamia Vascularia.

POIRAULT, G.— <i>Vegetative Organs of Vascular Cryptogams</i> .. .. .	715
---	-----

#### Muscineæ.

JÖNSSON, B.— <i>Respiration and Assimilation in Muscineæ</i> .. .. .	715
TILDEN, JOSEPHINE E.— <i>Elaters of Hepaticæ</i> .. .. .	716
MATTIROLLO, O.— <i>Revivification of Grimaldia</i> .. .. .	716

#### Characeæ.

RICHTER, J.— <i>Action of External Influences on the Characeæ</i> .. .. .	716
FILARSZKY, F.— <i>Monograph of Characeæ</i> .. .. .	716
KNOWLTON, F.— <i>Fossil Chara</i> .. .. .	717

#### Algæ.

JOHNSON, T.— <i>New Parasitic Alga</i> .. .. .	717
PALLA, E.— <i>Karyoid, a new Organ of Conjugatæ</i> .. .. .	717
WILDEMAN, E. DE— <i>Trentepohlia</i> .. .. .	717
SHAW, W. B., & OTHERS— <i>Pleodorina, a new Genus of Volvocineæ</i> .. .. .	717

#### Fungi.

LESAGE, P.— <i>Influence of the Tension of Aqueous Vapour on the Growth of Fungi</i> ..	718
ZOPF, W., & A. PRUNET— <i>New Genera of Chytridiaceæ</i> .. .. .	718
ZOPF, W.— <i>Woronina</i> .. .. .	718
” ” <i>Brefeld's Mesomyces</i> .. .. .	719

	PAGE
DANGEARD, P. A.— <i>Sexual Reproduction in the Ustilaginæ</i> .. .. .	719
"   "   " <i>Sexual Reproduction among the Ascomycetes</i> .. .. .	719
WEHMER, C.— <i>Sclerote-forming Species of Penicillium</i> .. .. .	720
MAUL, R.— <i>Sclerote in Alder-fruit</i> .. .. .	720
HAUTEFEUILLE, P., & A. PERREY— <i>Wine-Yeasts</i> .. .. .	720
DANGEARD, P. A.— <i>Structure of Yeasts and their Development</i> .. .. .	721
KOCH, A., & H. HOSÆUS— <i>Action of Yeasts on Glycogen</i> .. .. .	721
BAY, C.— <i>Spore-forming Saccharomyces</i> .. .. .	722
VUILLEMIN, P.— <i>Pedicel of the Teleutospores of Pucciniæ</i> .. .. .	722
KLEBAHN, H.— <i>Heterœcious Uredinæ</i> .. .. .	722
PEGLION, V., & OTHERS— <i>Parasitic Fungi</i> .. .. .	722
COBB, N. A., & F. A. F. C. WENT— <i>Diseases of the Sugar-cane</i> .. .. .	723
COSTANTIN, J., & L. MATRUCHOT— <i>Parasites of the Mushroom</i> .. .. .	723
LINDAU, G.— <i>Systematic Position of Ditiola</i> .. .. .	723
COSTANTIN, J., & L. MATRUCHOT— <i>Fixity of Race in Mushrooms</i> .. .. .	723
BAMBEKE, C. VAN— <i>Vascular Hyphæ in the Autobasidiomycetes</i> .. .. .	724
CAVARA, F.— <i>Parasitic Hymenogaster</i> .. .. .	724
MONTEZ, R.— <i>Selonosporium aquæductum (Musk-Fungus)</i> .. .. .	724
TERNI, C.— <i>Actinomyces Gruberi sp. n.</i> .. .. .	725

## Protophyta.

### a. Schizophycæ.

TILDEN, JOSEPHINE E.— <i>Filamentous Form of Protococcus</i> .. .. .	725
JÖNSSON, B.— <i>Parasite of Gunnera</i> .. .. .	725
DANGEARD, P. A.— <i>Stilococcus bacillaris</i> .. .. .	725

### B. Schizomycetes.

GALTIER, V.— <i>Influence of Bacterial Association</i> .. .. .	726
VICENTINI, P.— <i>Leptothrix racemosa</i> .. .. .	726
BÜSGEN, M.— <i>Polymorphism of Cladothrix</i> .. .. .	726
BATAILLON, E.— <i>Disease in Fresh Water</i> .. .. .	726
RANSOME, A., & S. DELÉPINE— <i>Influence of Natural Agents on Virulence of Tubercle Bacillus</i> .. .. .	726
CASSEDEBAT, P. A.— <i>Action of Sea Water on Microbes</i> .. .. .	727
MILLER— <i>Bacteriology of Teeth-pulp</i> .. .. .	727
PANE, N.— <i>Liquefaction of Gelatin by Streptococcus pyogenes</i> .. .. .	727
KUPRIANOW, J.— <i>Immunity to Diphtheria</i> .. .. .	727
LASER, H.— <i>Effect of Citric Acid on Diphtheria Bacillus</i> .. .. .	728
LECLEF, J.— <i>Sporicidal Action of Serum</i> .. .. .	728
DENYS, J.— <i>Bactericidal Power of the Body Juices</i> .. .. .	729
KOCH, A., & H. HOSÆUS— <i>New Frog-spawn Fungus</i> .. .. .	729
CATTERINA, G.— <i>Pathogenic Bacillus of Frogs</i> .. .. .	730
YERSIN— <i>Bacillus of Bubo Plague</i> .. .. .	730
METSCHNIKOFF, E.— <i>Cholera and Vibrios</i> .. .. .	730
CLAUSSEN, R.— <i>Variations of the Cholera Vibrio</i> .. .. .	731
SPRONCK, C. H. H.— <i>Cholera Vibrio of the Epidemic in Holland</i> .. .. .	731
SMITH, TH.— <i>Coarse and Fine Spirilla in Gut of Pig</i> .. .. .	731
VAN DER VELDE, H.— <i>Mechanism of the Virulence of Staphylococcus pyogenes aureus</i> .. .. .	732
HEIM, L., & BORDONI-UFFREDUZZI— <i>Manuals of Bacteriology</i> .. .. .	732
BIBLIOGRAPHY .. .. .	733

## MICROSCOPY.

### a. Instruments, Accessories, &c.

#### (1) Stands.

ROSS & Co's "Eclipse" Bacteriological Microscope (Fig. 81) .. .. .	734
"   "   "   Binocular Microscope (Fig. 82) .. .. .	736
"   "   "   Petrological Microscope (Fig. 83) .. .. .	736
COUTANT, R. B.— <i>Support for the Microscope (Figs. 84-87)</i> .. .. .	736

#### (2) Eye-pieces and Objectives.

MICHELS, J.— <i>New 1/5 Objective</i> .. .. .	737
AMANN, J.— <i>Koristka Semi-Apochromatic 1/15 Objective</i> .. .. .	737

#### (3) Illuminating and other Apparatus.

CLAY WICK for Microscope Lamps .. .. .	738
MAGNIFIER for Reading Small Print .. .. .	739
CROVA— <i>The New Photometry</i> .. .. .	739
KRÜSS, H.— <i>Colorimeter with Lummer-Brodhun Prism Pair (Figs. 88 and 89)</i> .. .. .	740



	PAGE
(4) Photomicrography.	
NEUHAUSS— <i>Photomicrograms of Ice and Snow Crystals</i> .. .. .	741
VOGEL— <i>The Optics of Photography</i> .. .. .	741
(5) Microscopical Optics and Manipulation.	
RÖNTGEN, W. G.— <i>Experiments with a Right-angled Prism</i> .. .. .	742
(6) Miscellaneous.	
THE LATE Mr. G. E. Blenkins, F.R.C.S. .. .. .	742
"   Mr. F. R. Cheshire .. .. .	743
SÄUGER— <i>Removal of Rust from Instruments</i> .. .. .	743

## B. Technique.

### (1) Collecting Objects, including Culture Processes.

MILLER, C. O.— <i>Aseptic Protozoa Cultures</i> .. .. .	744
KOSSOWITSCH, P.— <i>Apparatus for Pure Cultivation of Algæ</i> (Figs. 90 and 91) ..	744
WAEKER, J. H.— <i>Cultivation Capsule for Fungi</i> (Figs. 92 and 93) .. .. .	746
HEST, J. J. VAN— <i>Air Filter</i> (Figs. 94 and 95) .. .. .	747
BAY, J. C.— <i>Infection Needle</i> (Fig. 96) .. .. .	748
MIQUEL, P.— <i>Setting Cultivations on Solid Media</i> .. .. .	748
BUSSE, O.— <i>Parasitic Cell-inclusions and their Cultivation</i> .. .. .	748
KRÁL & OTHERS— <i>Cultivating Gonococcus</i> .. .. .	749
SCHUTZ, J. L.— <i>Rapid Method for making Nutrient Agar</i> .. .. .	750
DEYCKE— <i>Nutrient Media containing Alkali Albuminates</i> .. .. .	750

### (2) Preparing Objects.

MITSUKURI, K.— <i>Preparation and Preservation of Embryos of Chelonia</i> .. .. .	750
MÜLLER, G. W.— <i>Preserving Ostracoda</i> .. .. .	751
HEDA, V.— <i>Study of Mitosis</i> .. .. .	751

### (3) Cutting, including Imbedding and Microtomes.

KEIBEL, F.— <i>Small Auxiliary Apparatus for the Plate Modelling Method</i> (Figs. 97 and 98) .. .. .	752
HAMMER, J. A.— <i>Plate Models of Embryonic Liver</i> .. .. .	752
RABL, C.— <i>Methods for Examining Embryological Material</i> .. .. .	752
JELINEK, O.— <i>Use of Stablite for Celloidin Preparations</i> .. .. .	753
SCHAFFER, J.— <i>Glass Receptacle for Series of Sections</i> (Figs. 99–101) .. .. .	754

### (4) Staining and Injecting.

BERKLEY, H. J.— <i>Modification of Golgi Silver Stain</i> .. .. .	755
"   " <i>Staining Intrinsic Pulmonary Nerves of Mammalia</i> .. .. .	755
"   " <i>Nerve-Supply of Cardiac Ventricles</i> .. .. .	755
GALEOTTI, G.— <i>Staining Living Cells</i> .. .. .	755
SCALA, A.— <i>Artificial Colouring of Wine with Vegetable Substances</i> .. .. .	756
SEELMANN, H.— <i>Rapid Staining of Blood-corpuses</i> .. .. .	756
HESSERT, W.— <i>Flagella-Staining without a Mordant</i> .. .. .	756
ERNST, F.— <i>Spore-staining after Maceration</i> .. .. .	757
VINCENT, H.— <i>Staining Micro-organisms in the Blood</i> .. .. .	757

### (5) Mounting, including Slides, Preservative Fluids, &c.

OHLMACHER, A. P.— <i>Production of Artefacts by certain Fixatives</i> .. .. .	757
ZENKER'S <i>Fixatives</i> .. .. .	758
BLUM, J.— <i>Formol as a Preservative Fluid</i> .. .. .	758
LUSTIG, A.— <i>Pacini's Preserving Fluid</i> .. .. .	758
FISCHER, A.— <i>Fixing Methods and the Granula</i> .. .. .	758
RATTRAY, J.— <i>Preserving Tow-net Material</i> .. .. .	759
ZIEGLER, H. E.— <i>New Compressorium</i> (Fig. 102) .. .. .	759

### (6) Miscellaneous.

BENEKE & A. SEDGWICK— <i>Collection of Microscopic Preparations</i> .. .. .	760
LATAPIE, A.— <i>Fixing-boards for Experiments on Animals</i> .. .. .	760

### PROCEEDINGS OF THE SOCIETY:—

Meeting, 17th October, 1894 .. .. .	761
"   21st November, 1894 .. .. .	764
INDEX OF NEW BIOLOGICAL TERMS .. .. .	771
INDEX .. .. .	773
CONTENTS OF VOLUME .. .. .	vii

Authors of Papers printed in the Transactions are entitled to 20 copies of their communications *gratis*. Extra copies can be had at the price of 10s. 6d. per half-sheet of 8 pages, or less, including cover, for a minimum number of 50 copies, and 6s. per 100 plates, if plain. Prepayment by P.O.O. is requested.

# R. & J. BECK'S MICROSCOPES

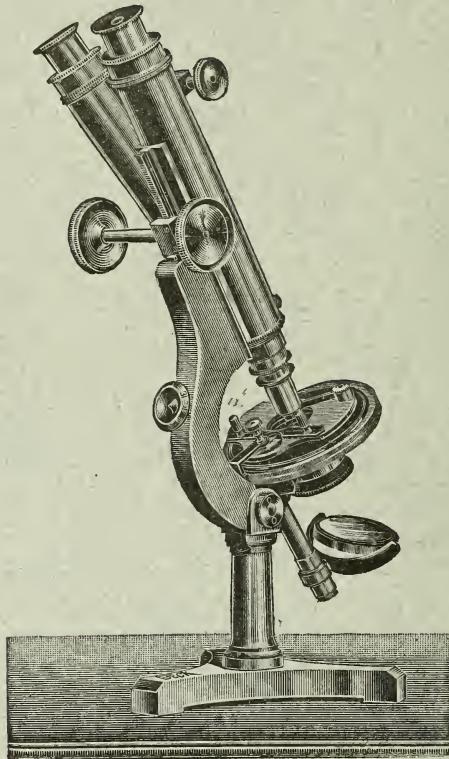

## No. 14c BINOCULAR "NATIONAL" MICROSCOPE.

The Binocular National Microscope, with rack-and-pinion coarse- and screw fine-adjustments, concentric rotating stage, concave mirror, rack and pinion adjustment to body of instrument for varying the distance between the eye-pieces for Stereoscopic vision. Two pairs of eye-pieces, 2-inch,  $\frac{3}{8}$ -inch, and  $\frac{1}{4}$ -inch object-glasses, side condensing lens on stand, iris diaphragm, forceps, pliers, and glass slip with ledge. Packed in polished mahogany case with lock and key and handle .. .. . £17 17 0

Double Nose-piece, 16s. 6d.; Triple Nose-piece, £2 extra.

---

NEW 1/12-INCH OIL-IMMERSION OBJECT-GLASS, £5 10s.

---

NEW FULLY ILLUSTRATED CATALOGUE FREE ON APPLICATION.

## R. & J. BECK, LTD., 68 CORNHILL, LONDON, E.C.

FACTORY: LISTER WORKS, KENTISH TOWN, N.W.



The Journal is issued on the third Wednesday in  
February, April, June, August, October, and December.

1894. Part 5.

OCTOBER.

To Non-Fellows,  
Price 6s.

NOV 27 1894 JOURNAL

6994

OF THE  
ROYAL  
MICROSCOPICAL SOCIETY;

CONTAINING ITS TRANSACTIONS AND PROCEEDINGS,

AND A SUMMARY OF CURRENT RESEARCHES RELATING TO

ZOOLOGY AND BOTANY

(principally Invertebrata and Cryptogamia),

MICROSCOPY, &c.

*Edited by*

**F. JEFFREY BELL, M.A.,**

*One of the Secretaries of the Society*

*and Professor of Comparative Anatomy and Zoology in King's College;*

WITH THE ASSISTANCE OF THE PUBLICATION COMMITTEE AND

**A. W. BENNETT, M.A., B.Sc., F.L.S.,**

*Lecturer on Botany at St. Thomas's Hospital,*

**R. G. HEBB, M.A., M.D. (Cantab.), AND**

**J. ARTHUR THOMSON, M.A.,**

*Lecturer on Zoology in the School of Medicine,*

*Edinburgh,*

FELLOWS OF THE SOCIETY.



LONDON:

TO BE OBTAINED AT THE SOCIETY'S ROOMS,

20 HANOVER SQUARE, W.;

OF MESSRS. WILLIAMS & NORGATE; AND OF MESSRS. DULAU & CO.

# CONTENTS.

## SUMMARY OF CURRENT RESEARCHES.

### ZOOLOGY.

#### A. VERTEBRATA:—Embryology, Histology, and General.

##### a. Embryology.

	PAGE
HUBRECHT, A. A. W.— <i>Morphology of Placenta</i> .. .. .	541
HOLL, M.— <i>Maturation of the Ovum in Mammals</i> .. .. .	541
LOCY, W. A.— <i>Segmentation in Medullary Folds and Embryonic Rim</i> .. .. .	542
WOODWARD, M. F.— <i>Succession and Genesis of Mammalian Teeth</i> .. .. .	542
" " <i>Milk Dentition of Rodents</i> .. .. .	542
POULTON, E. B.— <i>Homologies and Origin of Mammalian Hair</i> .. .. .	543
SAINT-REMY, G.— <i>Relations of Notochord and Hypophysis in Birds</i> .. .. .	544
DRASCH, O.— <i>Formation of Somatopleure and Vessels in the Chick</i> .. .. .	544
PLATT, J. B.— <i>Ectodermic Differentiation in Necturus</i> .. .. .	544
MINGAZZINI, P.— <i>Degeneration of Frog Ova</i> .. .. .	545
BORN, G.— <i>Structure of the Nucleus in the Ovarian Ovum of Triton</i> .. .. .	545
RÖSE, C.— <i>Development of Teeth in Fishes</i> .. .. .	546
HILL, C.— <i>Epiphysis of Teleostean Fishes and of Amia</i> .. .. .	546
JUNGENSEN, H. F. E.— <i>Development of the Kidneys in Amia calva</i> .. .. .	546
SCHAPER, A.— <i>Development of Cerebellum in Teleostei</i> .. .. .	547
HARRISON, R. G.— <i>Development of Fins of Teleostei</i> .. .. .	547
HUBBARD, J. W.— <i>Yolk-nucleus in Cymatogaster aggregatus</i> .. .. .	548
HOFFMANN, C. K.— <i>Development of the Selachian Head</i> .. .. .	548
EISMOND, J.— <i>Development of Amphioxus</i> .. .. .	549

##### β. Histology.

BERGH, R. S.— <i>The Cell and the Animal Tissues</i> .. .. .	549
RATH, O. VOM— <i>Number of Chromosomes in Animal-cells</i> .. .. .	549
HAECKER, V.— <i>Generative and Embryonic Mitoses</i> .. .. .	550
SCHAFFER, J.— <i>Histology and Histogenesis of Striped Muscle</i> .. .. .	550

##### γ. General.

KOCHS, W.— <i>Is there a Cell-life without Micro-organisms</i> .. .. .	551
HAACKE, W.— <i>Haacke's Theory of Gemmaria</i> .. .. .	551
KOSSEL, A., & A. NEUMANN— <i>Disruption Products of Nuclein Acid</i> .. .. .	552
ZACHARIAS, O.— <i>Distribution of Lacustrine Plankton</i> .. .. .	552

#### B. INVERTEBRATA.

PLATEAU, F.— <i>False Mimicry</i> .. .. .	552
WALKER, J. J.— <i>Terrestrial Fauna of Damma Island, East Indian Archipelago</i> .. .. .	552

##### Mollusca.

##### a. Cephalopoda.

APPELLÖF, A.— <i>Shells of Sepia, Spirula, and Nautilus</i> .. .. .	552
JOUBIN, L.— <i>Cephalopoda of Amboina</i> .. .. .	554
RACOVITZA, E. G.— <i>Copulation of Cephalopoda</i> .. .. .	554
" " <i>Fecundation of Octopus vulgaris</i> .. .. .	554
KORSCHULT— <i>Spawn and Embryos of Eledone</i> .. .. .	555

##### β. Pteropoda.

KNOWER, H. MCE.— <i>Pteropods with Two Separate Sexual Orifices</i> .. .. .	555
---	-----

##### γ. Gastropoda.

KOFROID, C. A.— <i>Laws of Cleavage in Limax</i> .. .. .	555
ERLANGER, R. V.— <i>Primitive Nephridia of Lymnaeus</i> .. .. .	556
JHERING, H. VON— <i>Peltella</i> .. .. .	556

	PAGE
PLATE, L.— <i>Renal and Circulatory Organs of Chitons</i> .. .. .	556
„ „ <i>Oncidiella coquimbensis</i> .. .. .	556
<b>δ. Lamellibranchiata.</b>	
WÖHRMANN, S. VON— <i>Systematic Position of Trigonidæ</i> .. .. .	556
<b>Molluscoida.</b>	
<b>α. Tunicata.</b>	
LEFEVRE, G.— <i>Vertebration of Tail of Appendiculariæ</i> .. .. .	557
WARHAM, A. E.— <i>Variations in the Dorsal Tubercle of Ascidia virginea</i> .. .. .	557
<b>Arthropoda.</b>	
DIXON, H. H.— <i>Walking of some Arthropoda</i> .. .. .	557
<b>α. Insecta.</b>	
HEYMONS, R.— <i>Formation of Germinal Layers in Insects</i> .. .. .	557
ANDEREGG, E.— <i>Alternation of Generations in Insects</i> .. .. .	558
XAMEN— <i>Metamorphoses of Insects</i> .. .. .	558
STANDFUSS, M.— <i>Relations between Colouring and Habit in Lepidoptera</i> .. .. .	558
SEITZ, AD.— <i>Reproduction in Butterflies</i> .. .. .	559
PACKARD, A. S.— <i>Transformations of Saturniidæ</i> .. .. .	559
PHISALIX, C.— <i>Red Pigment of Pyrrhocoris apterus</i> .. .. .	559
KNOWER, H. MCE.— <i>Origin of the "Nasutus" (Soldier) of Eutermes</i> .. .. .	560
WERNER, F.— <i>Alimentary Canal of Orthoptera</i> .. .. .	560
D'HERCULAIS, J. KÜNCKEL— <i>Oviposition in Acrididæ</i> .. .. .	560
„ „ <i>Diptera Parasitic on Acrididæ</i> .. .. .	560
<b>γ. Protracheata.</b>	
POCOCK, R. I.— <i>Peripatus</i> .. .. .	561
<b>δ. Arachnida.</b>	
BERNARD, H. M.— <i>Vestigial Stigmata in Arachnida</i> .. .. .	561
JAWOROWSKI, A.— <i>Development of Pulmonary Sacs in Arachnids</i> .. .. .	561
PURCELL, F.— <i>Eye of Phalangiidæ</i> .. .. .	562
CARPENTER, G. H.— <i>Irish Pycnogonida</i> .. .. .	562
BERNARD, H. M.— <i>Systematic Position of Trilobites</i> .. .. .	562
<b>ε. Crustacea.</b>	
ZEHNTNER, L.— <i>Crustacea of Malay Archipelago</i> .. .. .	563
ALLEN, E. J.— <i>Histology of Nervous System of Embryonic Lobster</i> .. .. .	563
BUTSCHINSKY, P.— <i>Development of Gebia littoralis</i> .. .. .	564
MILNE-EDWARDS, A., & E. L. BOUVIER— <i>Calatheidæ</i> .. .. .	565
BOUVIER, E. L.— <i>Lomisinæ</i> .. .. .	566
RACOVITSA, E. G.— <i>Habits of Pilumnus hirtellus</i> .. .. .	567
BELL, F. JEFFREY— <i>Thelphusæ from Eastern Africa</i> .. .. .	567
SCOURFIELD, D. J.— <i>Entomostraca of Wanstead Park</i> .. .. .	567
<b>Vermes.</b>	
<b>α. Annelida.</b>	
WATSON, A. T.— <i>Habits of Amphicteniidæ</i> .. .. .	567
SMIBNOW, A.— <i>Free Nerve-endings in the Epithelium of the Earthworm</i> .. .. .	568
BEDDARD, F. E.— <i>Oligochæta of Eastern Tropical Africa</i> .. .. .	568
„ „ <i>New Genera of Earthworms from Western Tropical Africa</i> .. .. .	569
BOURNE, A. G.— <i>Anatomy and Development of some Earthworms</i> .. .. .	569
„ „ <i>Moniligaster</i> .. .. .	569
<b>β. Nemathelminthes.</b>	
COBB, N. A.— <i>Nematodes and Sugar Cane</i> .. .. .	570
APÁTHY, S.— <i>Conducting Element in the Muscle-fibres of Ascaris</i> .. .. .	570
FONT Y TORNÉ— <i>Filariosis in Europe</i> .. .. .	570
SONSINO, P.— <i>Helminthological Notes</i> .. .. .	570



## γ. Platyhelminthes.

JOUBIN, L.— <i>French Nemertinea</i> .. .. .	571
FAHRMANN, O.— <i>Turbellaria-Fauna of Basle</i> .. .. .	571
CERFONTAINE, P.— <i>New Tristomid</i> .. .. .	571
"   " <i>Striated Muscular Fibres in a Trematode</i> .. .. .	571
CHATIN, J.— <i>Development and Formation of Excretory Canals in Cercaria echinata</i>	572
LÜHE, M.— <i>Anatomy of Teniidæ</i> .. .. .	572
MONTICELLI, F. S.— <i>Ligula as Food in Italy</i> .. .. .	573

## δ. Incertæ Sedis.

MORGAN, T. H.— <i>Development of Balanoglossus</i> .. .. .	573
LEVANDER, K. M.— <i>Pedalion</i> .. .. .	574
JENNINGS, H. S.— <i>Rotatoria of Michigan</i> .. .. .	574

## Echinoderma.

CHADWICK, H. C.— <i>Hæmal and Water-vascular Systems of Asteroidea</i> .. .. .	574
--	-----

## Cœlentera.

HEIDER, K.— <i>Gastrodes</i> .. .. .	575
MAAS, O.— <i>Craspedote Medusæ of the Plankton</i> .. .. .	575
FOWLER, G. H.— <i>New Veretillid</i> .. .. .	576
BUNTING, M.— <i>Origin of Sex-cells in Hydractinia</i> .. .. .	576

## Porifera.

HANITSCH, R.— <i>Generic Nomenclature of Bowerbank's British Sponges</i> .. .. .	576
--	-----

## Protozoa.

JOHNSON, H. P.— <i>Plastogamy of Actinosphærium</i> .. .. .	577
DE AMICIS, G. A.— <i>Pliocene Foraminifera</i> .. .. .	577
BLOCHMANN, F., & KEUTEN— <i>Nuclear Division in Euglena</i> .. .. .	577
BOSANQUET, W. C.— <i>Gregarine of Lumbricus herculeus</i> .. .. .	577
GUILLEBEAU, A.— <i>Coccidium in Cattle</i> .. .. .	577
LABBÉ, A.— <i>Endoglobular Parasites of Blood of Vertebrates</i> .. .. .	578
FRANCÉ, RAOUL— <i>Polytomææ</i> .. .. .	579
LEVANDER, K. M.— <i>Chain-forming Peridinium</i> .. .. .	580
FISCHER, A.— <i>Flagella</i> .. .. .	580
KAHANE, M.— <i>Living Parasites in the Blood of Cancerous Persons</i> .. .. .	580

## BOTANY.

A. GENERAL, including the Anatomy and Physiology  
of the Phanerogamia.

## a. Anatomy.

## (1) Cell-structure and Protoplasm.

STRASBURGER, E.— <i>Centrospheres of the Nucleus and Size of Cells</i> .. .. .	581
FARMER, J. B., & J. REEVES— <i>Centrospheres in the Spores of Pellia</i> .. .. .	581
ZIMMERMANN, A.— <i>Function of the Nucleus</i> .. .. .	582
ZACHARIAS, E.— <i>Growth of the Cell and Nature of the Nucleus</i> .. .. .	582
ZIMMERMANN, A.— <i>Behaviour of the Nucleoles during Karyokinesis</i> .. .. .	583
HUMPHREY, J. E.— <i>Nucleoles and Centrosomes</i> .. .. .	583
SCHULZE, E.— <i>Chemistry of the Cell-wall</i> .. .. .	583
SCHIPS, K.— <i>Cuticular Formations</i> .. .. .	584

## (2) Other Cell-contents (including Secretions).

ZIMMERMANN, A.— <i>Chromatophores</i> .. .. .	584
FAMINTZIN, A., & E. BELZUNG— <i>Chlorophyll-grains in Seeds and Seedlings</i> .. .. .	584

## (3) Structure of Tissues.

GOEBEL, K.— <i>Structure of Aquatic Plants</i> .. .. .	585
SCHILLING, A. J.— <i>Formation of Mucilage by Aquatic Plants</i> .. .. .	585
GODFRIN, J.— <i>Resin-canals in Abies pectinata</i> .. .. .	585
MANGIN, L.— <i>Muciferous and Resiniferous Cells in the Yew</i> .. .. .	586
WILCOX, E. M., & E. W. OLIVE— <i>Histology of Pontederia</i> .. .. .	586



	PAGE
SCHRENK, H.— <i>Parasitism of Epiphegus</i> .. .. .	586
KÜSTENMACHER, M.— <i>Structure and Composition of Galls</i> .. .. .	586
SCHNEIDER, A.— <i>Root-tuberles of Leguminosæ</i> .. .. .	586
MACDOUGAL, D. T.— <i>Root-tuberles of Isopyrum</i> .. .. .	587

#### (4) Structure of Organs.

CAVARA, F.— <i>Male Flowers of the Box</i> .. .. .	587
MÜLLER, LUISE— <i>Anatomy of Petals</i> .. .. .	587
RACIBORSKI, M.— <i>Morphology of the Cabombaceæ and Nymphæaceæ</i> .. .. .	588
SCHMID, R.— <i>Embryo of Phanerogams</i> .. .. .	588
ZABRISKIE, J. L.— <i>Endosperm of Phytelphas and Smilacina</i> .. .. .	588
WENT, F. A. F. C.— <i>Aerial Roots of Epiphytes</i> .. .. .	588

### β. Physiology.

#### (1) Reproduction and Embryology.

BUSCALIONI, L.— <i>Embryo-sac of Plantago</i> .. .. .	589
KNUTH, P., & OTHERS— <i>Cross-pollination and Self-pollination</i> .. .. .	589
GREEN, J. R.— <i>Germination of Pollen-grains</i> .. .. .	590

#### (2) Nutrition and Growth (including Germination, and Movements of Fluids).

JÖNSSON, B.— <i>Influence of Light on the Germination of Seeds</i> .. .. .	590
TOLOMEI, G.— <i>Action of Magnetism on Germination</i> .. .. .	590
PEFFFER, W.— <i>Work and Pressure in Growing Plants</i> .. .. .	590
SACHS, J.— <i>Mechanomorphosis</i> .. .. .	591
SAUVAGEAU, C.— <i>Propagation of Potamogeton</i> .. .. .	591
HABERLANDT, G.— <i>Nutrition of Viviparous Mangrove-plants</i> .. .. .	591
ENGELMANN, TH. W.— <i>Production of Oxygen and Chlorophyll</i> .. .. .	592
KOSSOWITSCH, P.— <i>Fixation of Free Nitrogen by Algæ</i> .. .. .	592
GANONG, W. F.— <i>Absorption of Water by the Green Parts of Plants</i> .. .. .	592
SCHWENDENER, S., & E. STRASBURGER— <i>Ascent of Sap</i> .. .. .	593

#### (3) Irritability.

MACFARLANE, J. M.— <i>Irrito-contractility</i> .. .. .	593
--	-----

#### (4) Chemical Changes (including Respiration and Fermentation).

COSTERUS, J. C.— <i>Storing up and Transport of Starch</i> .. .. .	593
PUBJEWICZ, K.— <i>Formation and Decomposition of Organic Acids</i> .. .. .	594
PALLADINE, W.— <i>Intramolecular Respiration dependent upon Carbohydrates</i> .. .. .	594
IWANOWSKI, D.— <i>Influence of Oxygen on Alcoholic Fermentation</i> .. .. .	594

## B. CRYPTOGAMIA.

### Cryptogamia Vascularia.

HEINSEN, E.— <i>Megaspore and Female Prothallium of Selaginella</i> .. .. .	594
GIBSON, R. J. HARVEY— <i>Stem of Selaginella</i> .. .. .	595
MATOUSCHEK, F.— <i>Bulbs of Cystopteris bulbifera</i> .. .. .	595
HOLLICK, A.— <i>Fossil Salvinias</i> .. .. .	595
POTONTÉ, H.— <i>Position of Sphenophyllaceæ</i> .. .. .	595

### Muscineæ.

LORCH, W.— <i>Anatomy of Mosses</i> .. .. .	596
MORIN, F.— <i>Venation of the Muscineæ</i> .. .. .	596
BRITTON, E. G.— <i>Physcomitrium</i> .. .. .	596
RABENHORST'S <i>Cryptogamic Flora of Germany (Musci)</i> .. .. .	596
BRIZI, U.— <i>Fossil Bryophytes</i> .. .. .	597

### Algæ.

COHN, F.— <i>Formation and Erosion of Rocks by Algæ</i> .. .. .	597
CHODAT, R., & J. HUBER— <i>Classification of the Lower Green Algæ</i> .. .. .	597
AGARDE, J. G.— <i>New Genera and Species of Algæ</i> .. .. .	598
SCHMITZ, F.— <i>Schizymenia</i> .. .. .	598
JOHNSON, T.— <i>Systematic Position of the Bangiaceæ</i> .. .. .	599
BORDET, J.— <i>Irritability of Spermatozooids of Fucaceæ</i> .. .. .	599
HUBER, J.— <i>Bulbils of Chætonema</i> .. .. .	599
CHODAT, R., & J. HUBER— <i>Development of Pediastrum</i> .. .. .	599

	PAGE
DE TONI'S <i>Sylloge Algarum</i> .. .. .	600
JAMES, J. F.— <i>Fucoides</i> .. .. .	600

### Fungi.

ZOPF, W.— <i>Pigments of Fungi</i> .. .. .	600
"   " <i>Erysiphea-like Fructification in the Saprolegniaceæ</i> .. .. .	600
BACHMANN, J.— <i>Sporanges of Thamnidium elegans</i> .. .. .	600
JACZEWSKI, A. DE— <i>Classification of the Pyrenomycetes</i> .. .. .	601
TRABUT, L., & OTHERS— <i>Parasitic Fungi</i> .. .. .	601
WÖRNIE, P.— <i>Injuries produced by Gymnosporangium</i> .. .. .	601
FISCHER, E.— <i>Sclerote of Rhododendron</i> .. .. .	602
EJLKEMANN, C.— <i>Microbiology and Manufacture of Arrack</i> .. .. .	602
BEYERINCK, M. W.— <i>Schizosaccharomyces octosporus</i> .. .. .	602
BOCHICCHIO, N.— <i>Lactomyces inflans caseigrana</i> .. .. .	603
SCHRÖTER, J.— <i>History of Development of the Uredinææ</i> .. .. .	603
DIETEL, P.— <i>Alternation of Generations in the Uredinææ</i> .. .. .	603
"   " <i>Teleutospores of Uredinææ</i> .. .. .	603
LUDWIG, F.— <i>Fungus Flux of Trees</i> .. .. .	604
GASPARINI, G.— <i>Actinomyces</i> .. .. .	604
BRO & OTHERS— <i>Fungi of Favus</i> .. .. .	604
FERRY, R., & R. HERZER— <i>Fossil Fungi</i> .. .. .	605

### Protophyta.

#### a. Schizophyceæ.

LAGERHEIM, G. v.— <i>Snow-flora of Spitzbergen</i> .. .. .	605
ZOPF, W.— <i>Development of Dictyosphaerium</i> .. .. .	605
CHODAT, R.— <i>Development of Raphidium</i> .. .. .	605
MIQUEL, P.— <i>Re-establishment of the Size of Diatoms</i> .. .. .	606
LAUTERBORN, R., & O. MÜLLER— <i>Movements of Diatoms</i> .. .. .	606

#### β. Schizomycetes.

SCHICKHARDT, H.— <i>Effect of Sunlight on the Human Organism and on Micro-organisms</i> .. .. .	607
KOSSEL, H.— <i>Action of Nuclein Acid on Bacteria</i> .. .. .	607
PETRI, R. J., & A. MAASSEN— <i>Formation of Sulphuretted Hydrogen and Mercaptan by Aerobic Bacteria</i> .. .. .	607
LENTI, P.— <i>Influence of Alcohol, Glycerin, and Olive Oil on Disinfectants</i> .. .. .	608
WERTHEIM & SCHANTA— <i>Bacteriology in Surgery</i> .. .. .	608
RUSSELL, H. L.— <i>Bacterial Flora of the Atlantic Ocean</i> .. .. .	608
BEYERINCK, M. W.— <i>Filaments of Tubercles of Papilionaceæ</i> .. .. .	609
BOYCE, R., & OTHERS— <i>Action of Gravity on Bacterium Zopfii</i> .. .. .	609
ARLOING, S.— <i>Experimental Production of Bovine Peripneumonia</i> .. .. .	610
ABBOTT, A. C., & A. A. GHRISKEY— <i>Secondary Foci in Experimental Diphtheria</i> .. .. .	610
HAVET, J.— <i>Bactericidal Power of Dog's Blood, and its Richness in Leucocytes</i> .. .. .	610
SALVIOLI, J.— <i>Physiological Effect of the Soluble Products of Pyogenic Staphylococci</i> .. .. .	610
PAWLOWSKY & MAKSUTOFF— <i>Phagocytosis and Actinomycosis</i> .. .. .	611
WALDVOGEL, R.— <i>Growth of Streptococcus longus in Bouillon</i> .. .. .	611
FREMLIN, H. S.— <i>Differences between Bacterium coli commune and Bacillus typhosus</i> .. .. .	611
GRUBER, M.— <i>Cholera Vibrio and Diagnosis of Cholera</i> .. .. .	612
DELPECH— <i>Pyelonephritis due to Staphylococcus pyogenes aureus</i> .. .. .	613
LUNKEWITSCH, M.— <i>Bacillus typhi murium and Caucasian Field Mice</i> .. .. .	613
GAWRONSKY, N.— <i>Microbes in Normal Urethra of Women</i> .. .. .	613
KOSSEL— <i>Pathogenic Action of Bacillus pyocyaneus on Human Beings</i> .. .. .	613
CHAPMAN, D.— <i>Urobacillus liquefaciens septicus</i> .. .. .	613
BIBLIOGRAPHY .. .. .	614

### MICROSCOPY.

#### a. Instruments, Accessories, &c.

##### (1) Stands.

BECK'S (R. & J.) <i>Large "Continental" Model Microscope</i> (Fig. 55) .. .. .	615
KORISTKA'S <i>Microscopes</i> (Figs. 56 and 57) .. .. .	616
KORISTKA <i>Mineralogical Microscope</i> (Fig. 58) .. .. .	616
"   " <i>Microscope</i> (Fig. 59) .. .. .	620
SWIFT, J.— <i>Practical Instructions for Making a Student's Microscope</i> (Figs. 60-66) .. .. .	620



## (3) Illuminating and other Apparatus.

	PAGE
KORISTKA <i>Camera Lucida after Nacht</i> (Fig. 67) .. .. .	623

## (4) Photomicrography.

KORISTKA <i>Photomicrographic Cameras</i> (Figs. 68-70) .. .. .	627
NEUHAUSS, R.— <i>Comparison between Petroleum, Gas, and the Auer Incandescent Light with respect to their Usefulness for Photomicrographic Work</i> .. .. .	627

## (6) Miscellaneous.

COX, JACOB D.— <i>Plea for Systematic Instruction in the Technique of the Microscope at the University</i> .. .. .	627
CASTRACANE, A. F.— <i>Stereoscopic Vision applied to Diatoms</i> .. .. .	628

## β. Technique.

## (1) Collecting Objects, including Culture Processes.

LUBINSKI, W.— <i>Apparatus for Anaerobic Cultivations</i> (Figs. 71 and 72) .. .. .	628
HEWLETT, R. T.— <i>Bacteriological Examination of Air</i> (Fig. 73) .. .. .	629
” ” <i>Cultivation of Tetanus Bacillus</i> .. .. .	630
” ” <i>Cultivating Anaerobes in Agar</i> .. .. .	630
FRIEDRICH, P.— <i>Heating Arrangement of the Microscope for Bacteriological Purposes</i> .. .. .	630

## (2) Preparing Objects.

LOEB, J.— <i>Simple Method for Producing two or more Embryos from one Egg</i> .. .. .	630
BORN, G.— <i>Newt Ova</i> .. .. .	631
HILL, C.— <i>Study of Living Fish-Embryos</i> .. .. .	631
SANDERS, A.— <i>Examination of Nervous System of Myxine glutinosa</i> .. .. .	631
BUTSCHINSKY, P.— <i>Embryology of Gebia littoralis</i> .. .. .	631
CHADWICK, H. C.— <i>Examination of Starfishes</i> .. .. .	631
MORGAN, T. H.— <i>Preserving Larvæ of Balanoglossus</i> .. .. .	632
LABBÉ, A.— <i>Study of Endoglobular Parasites</i> .. .. .	632
ROSEN, F.— <i>Botanical Microtechnique</i> .. .. .	632
HEINSEN, E.— <i>Preparing Megaspore and Female Prothallium of Selaginella</i> .. .. .	632

## (3) Cutting, including Imbedding and Microtomes.

KORISTKA'S <i>Microtomes</i> (Figs. 74-76) .. .. .	635
PAL, J.— <i>Large Microtome for Brain-sections</i> (Figs. 77 and 78) .. .. .	636
INGHILLERI— <i>Quick Double-staining Method for Examination of Blood and Tissues</i> .. .. .	639
TIMOFEYEWSKI— <i>Demonstrating Nucleated Red Corpuscles</i> .. .. .	639
LETULLE— <i>Staining Tubercle Bacilli</i> .. .. .	640
BUNGE, R.— <i>Staining Flagella of Bacteria</i> .. .. .	640
BORCHARDT, M.— <i>Demonstration of Influenza Bacillus</i> .. .. .	640
RETTNER, E.— <i>Natural Injection</i> .. .. .	641

## (5) Mounting, including Slides, Preservative Fluids, &amp;c.

HARVEY, J. J.— <i>Method for Mounting Opaque Objects</i> (Fig. 79) .. .. .	641
FUNCK, E.— <i>Cleaning Cover-glasses</i> .. .. .	642
COHN, F.— <i>Uses of Formaldehyd</i> .. .. .	642
DONALDSON, H. H.— <i>Changes caused in Nervous Tissues by Hardening Reagents</i> .. .. .	642
BOHLAND & OTHERS— <i>Collecting and Preserving Urinary Sediment</i> (Fig. 80) .. .. .	643

## (6) Miscellaneous.

WÉVRE, A. DE— <i>Microchemical Reaction of Vegetable Albumen</i> .. .. .	644
--	-----

Authors of Papers printed in the Transactions are entitled to 20 copies of their communications gratis. Extra copies can be had at the price of 10s. 6d. per half-sheet of 8 pages, or less, including cover, for a minimum number of 50 copies, and 6s. per 100 plates, if plain. Prepayment by P.O.O. is requested.

# R. & J. BECK'S MICROSCOPES

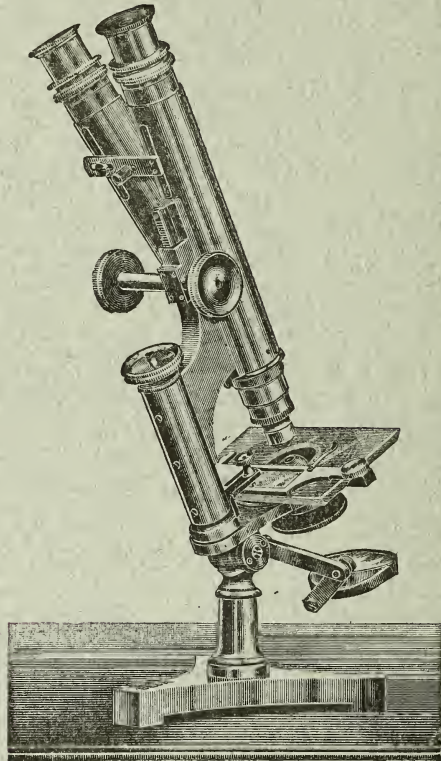

No. 30a BINOCULAR "ECONOMIC" MICROSCOPE,  
AS FIGURED;

With Two Pairs of Eye-Pieces; Three Object-Glasses 2-inch,  
1-inch, and  $\frac{1}{4}$ -inch; Plane and Concave Mirrors; Iris  
Diaphragm; Forceps; Pliers; Slip with ledge.

PACKED IN POLISHED MAHOGANY CASE,  
**£10 10s.**

Double Nose-piece, 12s. 6d.; Triple Nose-piece, 24s. extra.

**NEW  $\frac{1}{12}$ -INCH OIL-IMMERSION OBJECT-GLASS, £5 10s.**

FULL ILLUSTRATED DESCRIPTIVE CATALOGUE FREE ON APPLICATION.

**R. & J. BECK, LTD., 68 CORNHILL, LONDON, E.C.**

FACTORY: LISTER WORKS, KENTISH TOWN, N.W.



# APERTURE TABLE.

Numerical Aperture. ( $n \sin u = a$ .)	Corresponding Angle ( $2u$ ) for			Limit of Resolving Power, in Lines to an Inch.			Illuminating Power. ( $a^2$ .)	Penetrating Power ( $\frac{1}{a}$ )
	Air ( $n = 1.00$ .)	Water ( $n = 1.33$ .)	Homogeneous Immersion ( $n = 1.52$ .)	White Light. ( $\lambda = 0.5269 \mu$ , Line E.)	Monochromatic (Blue) Light. ( $\lambda = 0.4861 \mu$ , Line F.)	Photography. ( $\lambda = 0.4000 \mu$ , Near Line A.)		
1.52	..	..	180° 0'	146,543	158,845	193,037	2.310	.658
1.51	..	..	166° 51'	145,579	157,800	191,767	2.280	.662
1.50	..	..	161° 23'	144,615	156,755	190,497	2.250	.667
1.49	..	..	157° 12'	143,651	155,710	189,227	2.220	.671
1.48	..	..	153° 39'	142,687	154,665	187,957	2.190	.676
1.47	..	..	150° 32'	141,723	153,620	186,687	2.161	.680
1.46	..	..	147° 42'	140,759	152,575	185,417	2.132	.685
1.45	..	..	145° 6'	139,795	151,530	184,147	2.103	.690
1.44	..	..	142° 39'	138,830	150,485	182,877	2.074	.694
1.43	..	..	140° 22'	137,866	149,440	181,607	2.045	.699
1.42	..	..	138° 12'	136,902	148,395	180,337	2.016	.709
1.41	..	..	136° 8'	135,938	147,350	179,067	2.088	.709
1.40	..	..	134° 10'	134,974	146,305	177,797	1.960	.714
1.39	..	..	132° 16'	134,010	145,260	176,527	1.932	.719
1.38	..	..	130° 26'	133,046	144,215	175,257	1.904	.725
1.37	..	..	128° 40'	132,082	143,170	173,987	1.877	.729
1.36	..	..	126° 58'	131,118	142,125	172,717	1.850	.735
1.35	..	..	125° 18'	130,154	141,080	171,447	1.823	.741
1.34	..	..	123° 40'	129,189	140,035	170,177	1.796	.746
1.33	..	180° 0'	122° 6'	128,225	138,989	168,907	1.769	.752
1.32	..	165° 56'	120° 33'	127,261	137,944	167,637	1.742	.758
1.30	..	155° 38'	117° 35'	125,333	135,854	165,097	1.690	.769
1.28	..	148° 42'	114° 44'	123,405	133,764	162,557	1.638	.781
1.26	..	142° 39'	111° 59'	121,477	131,674	160,017	1.588	.794
1.24	..	137° 36'	109° 20'	119,548	129,584	157,477	1.538	.806
1.22	..	133° 4'	106° 45'	117,620	127,494	154,937	1.488	.820
1.20	..	128° 55'	104° 15'	115,692	125,404	152,397	1.440	.833
1.18	..	125° 3'	101° 50'	113,764	123,314	149,857	1.392	.847
1.16	..	121° 26'	99° 29'	111,835	121,224	147,317	1.346	.862
1.14	..	118° 0'	97° 11'	109,907	119,134	144,777	1.300	.877
1.12	..	114° 44'	94° 55'	107,979	117,044	142,237	1.254	.893
1.10	..	111° 36'	92° 43'	106,051	114,954	139,698	1.210	.909
1.08	..	108° 36'	90° 34'	104,123	112,864	137,158	1.166	.926
1.06	..	105° 42'	88° 27'	102,195	110,774	134,618	1.124	.943
1.04	..	102° 53'	86° 21'	100,266	108,684	132,078	1.082	.962
1.02	..	100° 10'	84° 18'	98,338	106,593	129,538	1.040	.980
1.00	180° 0'	97° 31'	82° 17'	96,410	104,503	126,998	1.000	1.000
0.98	157° 2'	94° 56'	80° 17'	94,482	102,413	124,458	.960	1.020
0.96	147° 29'	92° 24'	78° 20'	92,554	100,323	121,918	.922	1.042
0.94	140° 6'	89° 56'	76° 24'	90,625	98,223	119,378	.884	1.064
0.92	133° 51'	87° 32'	74° 30'	88,697	96,143	116,838	.846	1.087
0.90	128° 19'	85° 10'	72° 36'	86,769	94,053	114,298	.810	1.111
0.88	123° 17'	82° 51'	70° 44'	84,841	91,963	111,758	.774	1.136
0.86	118° 38'	80° 34'	68° 54'	82,913	89,873	109,218	.740	1.163
0.84	114° 17'	78° 20'	67° 6'	80,984	87,783	106,678	.706	1.190
0.82	110° 10'	76° 8'	65° 18'	79,056	85,693	104,138	.672	1.220
0.80	106° 16'	73° 58'	63° 31'	77,128	83,603	101,598	.640	1.250
0.78	102° 31'	71° 49'	61° 45'	75,200	81,513	99,058	.608	1.282
0.76	98° 56'	69° 42'	60° 0'	73,272	79,423	96,518	.578	1.316
0.74	95° 28'	67° 37'	58° 16'	71,343	77,333	93,979	.548	1.351
0.72	92° 6'	65° 32'	56° 32'	69,415	75,242	91,439	.518	1.389
0.70	88° 51'	63° 31'	54° 50'	67,487	73,152	88,899	.490	1.429
0.68	85° 41'	61° 30'	53° 9'	65,559	71,062	86,359	.462	1.471
0.66	82° 36'	59° 30'	51° 28'	63,631	68,972	83,819	.436	1.515
0.64	79° 36'	57° 31'	49° 48'	61,702	66,882	81,279	.410	1.562
0.62	76° 38'	55° 34'	48° 9'	59,774	64,792	78,739	.384	1.613
0.60	73° 44'	53° 38'	46° 30'	57,846	62,702	76,199	.360	1.667
0.58	70° 54'	51° 42'	44° 51'	55,918	60,612	73,659	.336	1.724
0.56	68° 6'	49° 48'	43° 14'	53,990	58,522	71,119	.314	1.786
0.54	65° 22'	47° 54'	41° 37'	52,061	56,432	68,579	.292	1.852
0.52	62° 40'	46° 2'	40° 0'	50,133	54,342	66,039	.270	1.923
0.50	60° 0'	44° 10'	38° 24'	48,205	52,252	63,499	.250	2.000
0.45	53° 30'	39° 33'	34° 27'	43,385	47,026	57,149	.203	2.222
0.40	47° 9'	35° 0'	30° 31'	38,564	41,801	50,799	.160	2.500
0.35	40° 58'	30° 30'	26° 38'	33,744	36,576	44,449	.123	2.857
0.30	34° 56'	26° 4'	22° 46'	28,923	31,351	38,099	.090	3.333
0.25	28° 58'	21° 40'	18° 56'	24,103	26,126	31,749	.063	4.000
0.20	23° 4'	17° 18'	15° 7'	19,282	20,901	25,400	.040	5.000
0.15	17° 14'	12° 58'	11° 19'	14,462	15,676	19,050	.023	6.667
0.10	11° 29'	8° 38'	7° 34'	9,641	10,450	12,700	.010	10.000
0.05	5° 44'	4° 18'	3° 46'	4,821	5,252	6,350	.003	20.000

# W. WATSON & SONS'

## "GRAND MODEL" VAN HEURCK MICROSCOPE,

FOR HIGH-POWER WORK AND PHOTO-MICROGRAPHY,

Constructed on exactly similar lines to our "B" van Heurck Microscope, but has the following special features:—

STAGE can be rotated completely in any position.

Mechanical movements of Stage controlled by two stationary milled heads, working on one centre.

Optical centre, when the instrument is set horizontally, 10 inches high.

Spread of tripod foot, over 10 inches in each direction.

Fine adjustment to Substage.

Rackwork and Sliding Drawtubes.

Full description of the above instrument, and Illustrated Catalogue of Microscopes and Apparatus, also classified list of 40,000 Microscopic Objects, forwarded post free on application to

### W. WATSON & SONS,

313 HIGH HOLBORN,

LONDON, W.C.,

AND

78 Swanston Street,

Melbourne,

Australia.



ESTABLISHED

1837



Awarded  
37 GOLD  
and other  
Medals  
at the  
principal  
Inter-  
national  
Exhibitions  
of the  
World.

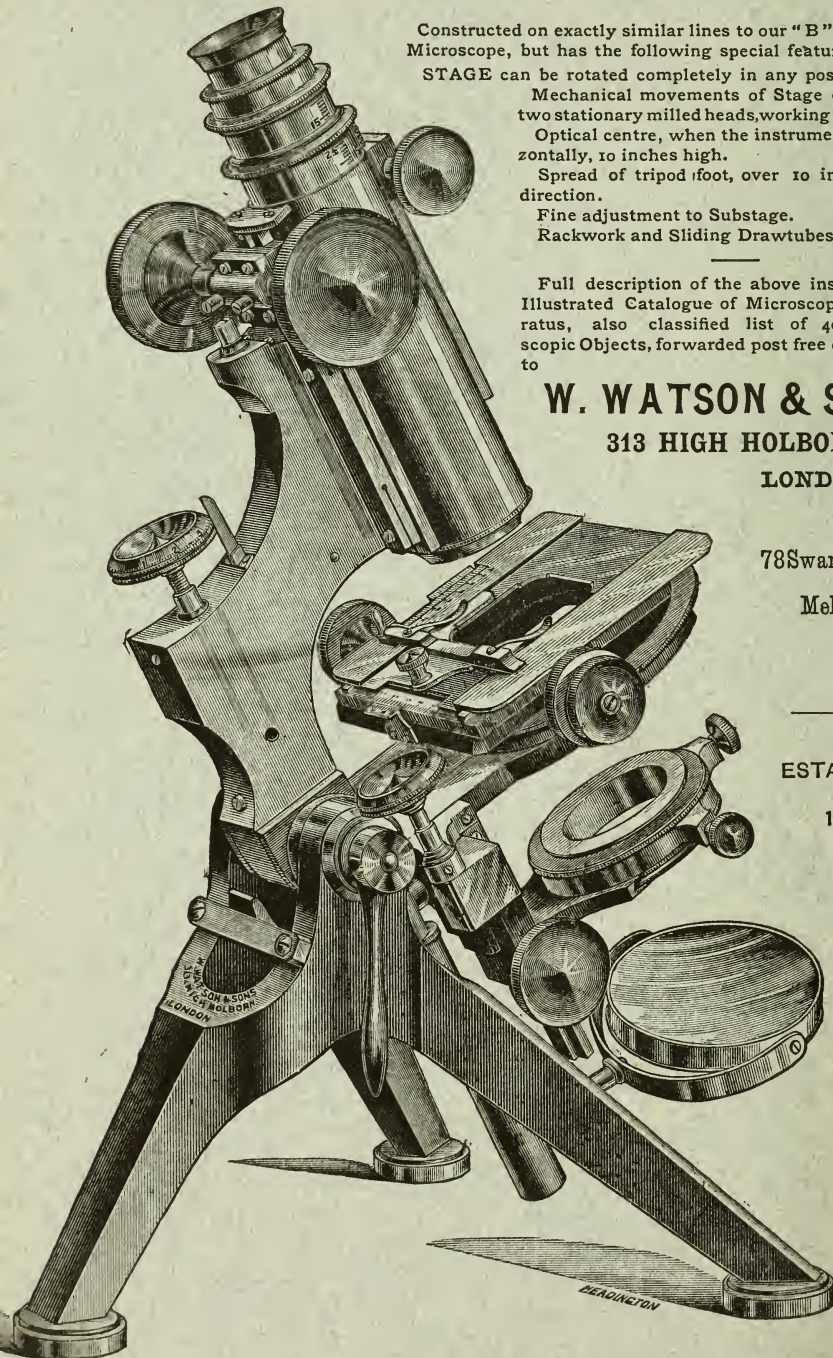











3 2044 128 439 742

Date Due

AUG 31 1956

