

SMITHSONIAN
MISCELLANEOUS COLLECTIONS

VOL. 93



"EVERY MAN IS A VALUABLE MEMBER OF SOCIETY WHO, BY HIS OBSERVATIONS, RESEARCHES,
AND EXPERIMENTS, PROCURES KNOWLEDGE FOR MEN"—SMITHSON

(PUBLICATION 3340)

CITY OF WASHINGTON
PUBLISHED BY THE SMITHSONIAN INSTITUTION
1935

The Lord Baltimore Press
BALTIMORE, MD., U. S. A.

ADVERTISEMENT

The present series, entitled "Smithsonian Miscellaneous Collections," is intended to embrace all the octavo publications of the Institution, except the Annual Report. Its scope is not limited, and the volumes thus far issued relate to nearly every branch of science. Among these various subjects zoology, bibliography, geology, mineralogy, anthropology, and astrophysics have predominated.

The Institution also publishes a quarto series entitled "Smithsonian Contributions to Knowledge." It consists of memoirs based on extended original investigations, which have resulted in important additions to knowledge.

C. G. ABBOT,
Secretary of the Smithsonian Institution.

CONTENTS

1. WRIGHT, W. H., and MCALISTER, E. D. The effect of ultraviolet radiation on the ova of the ascarid roundworms *Toxocara canis* and *Toxascaris leonina*. 13 pp., Dec. 26, 1934. (Publ. 3291).
2. SCHMITT, WALDO L. Mud shrimps of the Atlantic coast of North America. 21 pp., 4 pls., Feb. 15, 1935. (Publ. 3292.)
3. GATES, G. E. New earthworms from China, with notes on the synonymy of some Chinese species of Drawida and Pheretima. 19 pp., 15 figs., Feb. 27, 1935. (Publ. 3293.)
4. RANDERS-PEHRSON, N. H. Pioneer wind tunnels. 20 pp., 4 pls., 8 figs., Jan. 19, 1935. (Publ. 3294.)
5. RESSER, CHARLES ELMER. Nomenclature of some Cambrian trilobites. 46 pp., Feb. 14, 1935. (Publ. 3295.)
6. HRDLIČKA, ALEŠ. Ear exostoses. 100 pp., 5 pls., May 14, 1935. (Publ. 3296.)
7. MCALISTER, E. D. The Christiansen light filter: its advantages and limitations. 12 pp., 2 pls., 4 figs., Apr. 2, 1935. (Publ. 3297.)
8. BASSLER, R. S. The classification of the Edrioasteroidea. 11 pp., 1 pl., Apr. 4, 1935. (Publ. 3301.)
9. CANU, FERDINAND, and BASSLER, RAY S. New species of Tertiary cheilostome bryozoa from Victoria, Australia. 54 pp., 9 pls., Apr. 26, 1935. (Publ. 3302.)
10. STRONG, WILLIAM DUNCAN. An introduction to Nebraska archeology. 323 pp., 25 pls., 30 figs., July 20, 1935. (Publ. 3303.)

SMITHSONIAN MISCELLANEOUS COLLECTIONS
VOLUME 93, NUMBER 1

THE EFFECT OF ULTRAVIOLET RADIATION ON
THE OVA OF THE ASCARID ROUNDWORMS
TOXOCARA CANIS AND TOXASCARIS
LEONINA

BY

W. H. WRIGHT

Zoological Division, Bureau of Animal Industry,
U. S. Department of Agriculture

AND

E. D. McALISTER

Division of Radiation and Organisms,
Smithsonian Institution



(PUBLICATION 3291)

CITY OF WASHINGTON
PUBLISHED BY THE SMITHSONIAN INSTITUTION
DECEMBER 26, 1934

The Lord Baltimore Press
BALTIMORE, MD., U. S. A.

THE EFFECT OF ULTRAVIOLET RADIATION ON THE
OVA OF THE ASCARID ROUNDWORMS *TOXOCARA*
CANIS AND *TOXASCARIS LEONINA*

By W. H. WRIGHT,
Zoological Division, Bureau of Animal Industry,
U. S. Department of Agriculture

AND
E. D. McALISTER,
Division of Radiation and Organisms,
Smithsonian Institution

INTRODUCTION

Through the courtesy of Dr. C. G. Abbot, Secretary of the Smithsonian Institution, the opportunity was presented to study the action of ultraviolet light on the ova of the two species of ascarids commonly infesting the dog. It was desired in the experiments reported here to determine, if possible, the radiotoxic effect of ultraviolet light of different wave lengths and, as a practical measure, to correlate the possible sterilizing action of sunlight on the ova of these two species of ascarids.

The apparatus employed for the radiation of the ova, described in detail by Brackett and McAlister (1932), consisted of a quartz monochromator and a quartz mercury arc. This apparatus eliminates the disturbing effect of the large amount of heat attending all total arc exposures and permits irradiation by the different wave lengths of the mercury spectrum. The intensities of the spectral lines employed were as follows:

Wave length (A)	Intensity (ergs/sec. cm ²)
3650	9500
3130	4200
3022	1900
2967	910
2804	610
2652	570

In correlating the dosage employed with ultraviolet intensities in sunlight, the determinations of Coblenz and Stair (1931) have been used. These investigators gave the value of 65 microwatts per cm² (650 ergs/sec. cm²) for noonday, midsummer sun at Washington,

D. C., for wave lengths of 3130 Å to the solar limit at 2970 Å. From their data there have been computed an average value of 55 microwatts per cm^2 (550 ergs/sec. cm^2) for the above-mentioned wave lengths in July sunlight between 9:00 a. m. and 3:00 p. m. at Washington, D. C. This value has been used in translating into terms of days the exposures employed in some of the tests reported here.

The ova of *Toxocara canis* are globular, subglobular, or slightly ovoid in shape and of a light brown color. Externally, the egg is covered with a thick, albuminous coating which is mammillated at regular intervals. The eggs vary in measurement from 82 to 102 μ in length and 79 to 96 μ in width. The ova of *Toxascaris leonina* are ellipsoidal to subglobular or globular in shape, with thick, double-contoured, smooth, clear shells. They measure 82 to 96 μ in length and 82 to 92 μ in width.

REVIEW OF LITERATURE

The effect of ultraviolet irradiation on the ova of *Ascaris equorum* (= *A. megaloccephala*) has been studied in some detail by a number of investigators. Most of these experiments were conducted from the standpoint of the cytologist with a view to determining the effect of the light on various parts of the egg or on the whole egg at different stages of development. Stevens (1909), using a total arc exposure, found that exposure of the whole egg to ultraviolet light for 6 to 8 hours did not usually kill the egg at once, but prevented further development when the eggs were in the 2- to 4-cell stage at the time of exposure. Exposure for a period too short to prevent further cleavage ($\frac{1}{2}$ to 3 hours) caused various irregularities in development including irregular fragmentation of the chromosomes, delay in cleavage and abnormal gastrulation. Stevens believed that ova arrested in development may be said to be paralyzed to such an extent that they are unable to initiate any further mitosis.

In his extensive experiments in exposing various parts of the egg of *A. equorum* to ultraviolet light Schleip (1923) employed the microscopic method devised by Hertel (1904) and modified and improved by Tschachotin (1912). The apparatus used gave a spectral line of 2800 Å from the magnesium arc. Schleip found that irradiation of the whole egg or various parts of the egg for varying periods of time resulted in a marked lethal effect. Schleip concluded, moreover, that no part of the egg could be influenced by ultraviolet light without producing secondarily some alteration in other parts not exposed to the light.

Ruppert (1924) also employed the apparatus of Tschachotin in irradiating the ova of *A. equorum*. In Ruppert's experiments short

exposures of the whole egg resulted in marked abnormal embryonal development, which appeared most frequently in the gastrula stage. Longer exposures gave a marked lethal effect. Ruppert concluded that there is a rhythmic alteration in the lethal effect of ultraviolet light, depending on the stage of development of the egg at the time of exposure.

Seide (1925), in irradiating ova of *A. equorum*, used the method of Tschachotin as well as total arc exposures at wave lengths between 4050 and 2530 Å of the mercury spectrum. In his experiments there was no apparent lethal effect on the eggs and no apparent lag in development.

Nolf (1932) observed that a very small total arc exposure at wave lengths between 2800 and 3150 Å or between 1800 and 3150 Å was sufficient to prevent a large percentage of the ova of *Ascaris lumbricoides* from reaching embryonation. A slightly greater exposure was completely lethal to the eggs.

Although results obtained by the above-named investigators are of general interest, their findings offer no means of comparison with results of experiments reported in this paper, in which measured intensities of single wave lengths of ultraviolet light were employed. The intensity of the 2800 Å spectral line from the magnesium arc was not reported by those using this method, making comparison impossible, and it is equally impossible to compare results with those of workers who employed total arc exposures.

EXPERIMENTS

SERIES A

Preliminary tests were made by exposing *Toxocara* and *Toxascaris* eggs to six wave lengths of ultraviolet light in order to gain some idea as to lethal effect, if any, of these various wave lengths. The ova of both species of ascarids were mixed and placed on a glass slide and allowed to dry at room temperature. The slides were exposed to ultraviolet light for a length of time sufficient to provide an equivalent dosage (the product of time and intensity) at the various wave lengths. As the longest period of exposure was 20 minutes, each slide was dried for 20 minutes, including the time of exposure to the light, in order to provide equal conditions for the test. Each slide was then exposed to the arc for the time stated in Table 1. The dosage was 684,000 ergs/cm² or approximately equivalent for the 3022 Å slide to 18 minutes exposure to nooday, midsummer sun at Washington, D. C.

The exposed area on each slide was marked off with a diamond point; this area was equivalent to the dimensions of the light ray discharged from the aperture, or 5 by 30 mm. Eggs on the same slide outside of the irradiated area served as controls; the control eggs were therefore subjected to identically the same conditions during development as were the irradiated eggs. After exposure, each slide was immediately placed in a Petri dish and covered with a 1 per cent solution of formalin, in which the eggs were permitted to develop. For the most part the eggs adhered to the slide. The culture was allowed to develop for a period of 8 to 9 days at temperatures ranging from 26° to 28° C. At the end of this time, counts were made to determine the

TABLE 1.—Results of Exposure of Ova of *Toxocara canis* and *Toxascaris leonina* to Ultraviolet Light

Series A—Exposed on May 23, 1934

Dosage—684,000 ergs/cm²

No. of slide	Wave length	Duration of exposure		Date of count	Percentage embryonated			
		Minutes	Seconds		Toxocara		Toxascaris	
					Irradiated	Control	Irradiated	Control
	A			1934				
1	2652	20	..	May 31	27.5	32	6.5	25
2	2804	18	46	May 31	46	48	6	29.5
3	2967	12	30	June 1	51	50.5	20	22
4	3022	6	..	June 1	60.5	57	33	23.5
5	3130	2	44	June 1	49.5	47	27.5	23.5
6	3650	1	12	June 1	47	49.5	26	27

percentage of embryonation in the eggs of the two species, both on the control part of the slide and on the irradiated part of the slide. For each count, 200 ova were taken. Table 1 summarizes the results obtained from the irradiation of ova in series A.

From an examination of the data it is apparent that the relatively short exposure used in this series had little or no effect on the development of the ova in the majority of cases. However, in two instances the ultraviolet light appears to have exerted a definite toxic effect on the ova of *Toxascaris*. On slide 1 (wave length 2652 A) only 6.5 per cent of the irradiated ova became embryonated, whereas 25 per cent of the control ova became embryonated. On slide 2 (wave length 2804 A), 6 per cent of the irradiated ova were embryonated at the time the count was made, whereas 29.5 per cent of the control ova were

embryonated. In each of these instances it is apparent that the ultraviolet light prevented development in a relatively large proportion of the *Toxascaris* eggs. In other cases the differences in embryonation were well within the limits of experimental error in the counting technic.

SERIES B

In view of the fact that wave lengths from 2652 to 2967 Å are below the limits of the solar spectrum, there appeared to be little information of practical value to be derived from the further irradiation of ascarid eggs at these wave lengths even though *Toxascaris* ova were considerably affected by irradiation at wave lengths of 2652 and 2804 Å. For this reason further experiments were confined to irradiation of the ova at wave lengths within the range of the solar spectrum with a view to ascertaining the relative lethal effect of sunlight, exclusive of heat and desiccation, on the ova of these two species of ascarids. This point has practical application in the control of ascariasis.

In series B the ova were exposed to a dosage approximately equal to 40 times that used in series A. The dose was equivalent to 27,400,000 ergs/cm². This exposure for dish 1 (wave length 3022 Å) was approximately equivalent to 12 hours of noonday, midsummer sun at Washington, D. C.

For this test, a mixed culture of *Toxocara* and *Toxascaris* ova was dried in the bottom of 50-mm culture dishes for 10 minutes. After the eggs had dried on the bottom of the culture dish, water was added to the dish to a depth of 2 mm. This prevented drying of the culture during the period of irradiation. An area equivalent to the light aperture, or 5 by 30 mm, was marked off on the bottom of each culture dish with a diamond point and the eggs within that area were exposed to the ultraviolet light. Eggs without this area were not exposed and were used as controls. After exposure of the eggs, formalin was added to the culture dishes to provide a concentration of 1 per cent in order to prevent bacterial growth in the cultures. Temperatures during development of the cultures ranged between 29° and 30° C. Counts were made nine days after irradiation; 200 ova were taken in each count. The results of the experiment are recorded in table 2.

In only one case was there any apparent toxic effect from the ultraviolet irradiation in series B. In dish 1 (wave length 3022 Å) there resulted a marked lethal effect on the ova of both *Toxocara canis* and *Toxascaris leonina*, although the effect was most marked on the ova of the latter species. Of the ova exposed at this wave length, 24.5 per cent of the irradiated *Toxocara* eggs developed to embryonation, where-

as 58.5 per cent of the control eggs became embryonated. Only 8 per cent of the irradiated *Toxascaris* eggs developed, whereas 29 per cent of the control eggs became embryonated. A slight toxic effect may have been exerted on the ova exposed in dish 2 (wave length 3130 Å), although reference to the series C experiment would seem to indicate that the differences noted above are probably due to chance variation in the counts.

TABLE 2.—Results of Exposure of Ova of *Toxocara canis* and *Toxascaris leonina* to Ultraviolet Light

Series B—Exposed on June 5, 1934

Dosage—27,400,000 ergs/cm²

No. of dish	Wave length	Duration of exposure		Date of count	Percentage embryonated			
		Hours	Minutes		Toxocara		Toxascaris	
					Irradiated	Control	Irradiated	Control
	A			1934				
1	3022	4	..	June 14	24.5	58.5	8.0	29.0
2	3130	1	57 ^a	June 14	43.5	51.0	23.5	30.0
3	3650	..	48	June 14	56.5	51.0	28.5	30.0

^a 7 percent overdose.

SERIES C

In series C irradiation of *Toxocara* and *Toxascaris* ova with ultraviolet light was prolonged to the time indicated in table 3. The dosage used was approximately five times that employed in series B, and amounted to 137,000,000 ergs/cm². For dish 1 (wave length 3022 Å) the exposure utilized was approximately equivalent to 60 hours of noonday, midsummer sun at Washington, D. C., or 12 days of July sunlight.

The method of exposure used in series B was found unsatisfactory from the standpoint of making microscopic counts. Owing to the long exposure in series C, it was necessary to devise a more suitable method of irradiating the eggs so that drying would be prevented. There were constructed small glass dishes 5 mm wide, 30 mm long, and 5 mm high, the first two measurements representing the size of the area over which the light was dispersed from the aperture. A mixed culture of *Toxocara* and *Toxascaris* eggs was placed in the dishes and water added to a depth of approximately 3 mm. As evaporation proceeded during the course of irradiation, more water was added to prevent drying of the eggs.

A number of eggs sufficient to cover only the bottom of the dish was used in order to prevent any overlapping and shadowing of eggs from the ultraviolet light. After irradiation the eggs were transferred by means of a clean pipette to culture dishes containing a 1 per cent solution of formalin. As a control, a culture was made in 1 per cent formalin on the same date as the first irradiation exposure and was subjected to the same conditions of development as were the irradiated cultures. Temperatures during the period of development varied between 30° and 35° C., as recorded on a thermograph chart. Table 3 gives the results of this experiment. In this series 400 ova were taken for each count.

TABLE 3.—Results of Exposure of Ova of *Toxocara canis* and *Toxascaris leonina* to Ultraviolet Light

Series C—Exposed July 16, 18 and 20, 1934
Dosage—137,000,000 ergs/cm²

No. of dish	Wave length	Duration of exposure		Date of exposure	Date of count	Percentage embryonated			
		Hours	Minutes			Toxocara		Toxascaris	
						Irradiated	Control	Irradiated	Control
	A			1934	1934				
1	3022	20	..	July 16	July 27	20.5	65.5	1.5	42.0
2	3130	9	10	July 20	July 31	63.5	65.5	39.75	42.0
3	3650	4	..	July 18	July 28	63.0	65.5	46.5	42.0

It will be noted that the exposure to ultraviolet light at a wave length of 3022 A was the only exposure which produced any apparent toxic effect on the eggs of either species. The counts indicated that only 20.5 per cent of the irradiated *Toxocara* ova reached embryonation as compared with 65.5 per cent of the eggs embryonated in the control culture, and only 1.5 per cent of the irradiated *Toxascaris* ova became embryonated as compared with 42 per cent of the eggs embryonated in the control culture.

In this experiment the irradiated and control cultures were examined daily under the microscope. A careful check was made on the development of the cultures in an effort to determine whether there was any lag in development in those ova which actually started to segment. No such lag in development was noted. Those ova which segmented apparently began segmentation as promptly as did nonirradiated ova in the control culture.

The radiotoxic effect on the ova of both species was exhibited in different ways. On the ova of both *Toxocara* and *Toxascaris* it was apparent in some cases that the ultraviolet light had some direct and undelayed lethal effect, inasmuch as many eggs never underwent any cleavage. On the other hand, some of the ova of both species developed in part until development was definitely arrested. In order to check on this point, the culture in dish 1 (wave length 3022 Å) was recounted at the expiration of 21 days in an effort to determine whether any ova which were in intermediate stages of development at the time of the first count, 11 days after exposure, had completed their development. It was found that none of the ova which were partially developed at the time of the first count had completed their development at the time of the second count 10 days later. It would appear that such ova had been definitely and permanently arrested in development, a circumstance which agrees with the results obtained by Stevens (1909), who believed that such ova may be said to be paralyzed to such an extent that they are unable to initiate any further mitosis.

In some of the ova arrested in the course of development it was apparent that cleavage had proceeded normally up to a certain point. On the other hand, all sorts of irregularities were noted in the developmental stages of some of these eggs. These irregularities were most frequent in *Toxocara* ova. In some the cytoplasm was apparently degenerated and was distributed in various areas within the shell. In other ova the cytoplasm contained large vacuoles. Irregularities and abnormalities in blastulation and gastrulation were marked. Some of the *Toxocara* ova contained partly formed embryos, the unformed remainders of which were composed of undifferentiated and irregularly formed masses of cells. In some of the eggs the first somatic stem cell failed to develop, whereas the first germinal stem cell divided many times. In other eggs the first germinal stem cell developed only partly. In most of the *Toxascaris* ova that showed development it would appear that segmentation proceeded normally up to the 8- to 16-cell stage, at which stage it was definitely arrested. Development in none of these ova proceeded to the blastula or gastrula stage, except in a very few eggs which actually reached embryonation. In all ova of both species which became embryonated, the larvae appear to have ensheathed normally.

In order to determine the infectivity of embryos which developed in the irradiated ova, on August 11, 1934, the three cultures irradiated in series C were each fed to a young albino rat; at the same time the control culture was fed to a rat from the same litter. The rat which received the control culture gave birth to a litter of 10 young on August

17, 1934. As it was desired to raise this litter, the animal was not killed. The three other rats were killed on August 17, 18, and 21, 1934, respectively. Ascarid larvae were recovered from the liver and lungs of each of the three animals. All of these larvae proved to be those of *Toxocara canis*. Failure to recover *Toxascaris* larvae from the rats was not unexpected, as only a very limited supply of *Toxascaris leonina* ova was available at the start of the experiment and the cultures contained only a relatively few ova of this species. Failure to recover larvae is therefore not regarded as definite evidence that the embryos within the ova were not infective.

In all of the experiments in which any radiotoxic effect was noted from ultraviolet irradiation, *Toxascaris* eggs appeared to be the most severely affected by the exposure. In series C, the lethal effect apparently resulted in a definite killing of the ova without any segmentation, or in an arrest in development during the early stages of segmentation. In no case did *Toxascaris* eggs which were arrested in development reach the blastula or gastrula stages. This is in contrast to the effect on *Toxocara* ova in which blastulation or gastrulation, even though abnormal, was reached in some cases. It would appear that the more marked radiotoxicity on the eggs of *Toxascaris* may be associated with the smooth, rather clear, nonmammillated shell of these eggs, in contradistinction to the mosaically formed, mammillated, more darkly pigmented shell of *Toxocara*. It is believed that the mosaic pattern of the shell of this species of egg would tend to diffuse the ultraviolet rays and that the deeper pigmentation of these eggs would be responsible for some absorption of the ultraviolet spectrum before the rays had had an opportunity to reach the cytoplasm or nucleus of the egg.

CORRELATION OF PRESENT RESULTS WITH PREVIOUS INVESTIGATIONS

A number of investigators have reported on the effect of exposing the ova of various species of ascarids to sunlight. Ross (1916) reported that the eggs of the human ascarid, *Ascaris lumbricoides*, developed and remained alive when kept for 6 weeks on glass slides in the direct sunlight in India; Ross was of the opinion that a relatively high humidity was not essential for the development of the eggs. Ross's observation is at variance with the results obtained by Manalang (1927), who found that human ascarid eggs on glass slides were all dead after 1½ hours' exposure to the direct sunlight in the Philippines, although such eggs resisted an exposure of one-half hour. However, Ohba (1926) reported that ascarid eggs in water cultures in

direct sunlight continued to develop. Brown (1927) exposed the eggs of *A. lumbricoides* to direct sunlight in Panama by placing them in sand, and after a period of 21 days of such exposure it was found that all of the ova had degenerated. Brown considered that the destruction of the ova was due to two factors, viz, high temperature and desiccation. Soil temperatures in the sand cultures were found to reach at least 123° F., which appears to be above the lethal range of heat for ova of this species. Caldwell and Caldwell (1928) exposed fecal-soil cultures of the ova of the human and pig ascarids to sunlight in Alabama, and after a period of 3 days' exposure, the ova in all cultures were disintegrated. The maximum temperature recorded in the cultures was 146° F. These investigators place great emphasis on desiccation as the chief lethal factor involved, inasmuch as cultures moistened at hourly intervals while exposed to sunlight showed little disintegration of the ova of the pig ascarid; ova of the human ascarid showed less resistance. Otto (1929) reported that eggs of the human ascarid developed and remained alive over the summer of 1928 on the surface of clay, loam, sand, and cinder-loam soils in the shade in southwestern Virginia. Many of the eggs on the first three soils in the sun died rapidly, but after 160 days about one-fourth of the eggs isolated were still alive, whereas most of those on cinders in the sun died before becoming embryonated. The high temperatures recorded on the surface of the cinders lead the author to conclude that temperature played an important part in the death of these eggs.

Apparently, Owen (1930) is the only investigator to observe the effect of sunlight on the ova of *Toxocara canis*. Owen exposed the ova of this species to summer sunlight in Kentucky and Minnesota and found that such ova disintegrated before reaching the infective stage. A surface-soil temperature of 131.9° F. was obtained on the plots of soil on which the eggs were exposed. Owen was of the opinion that the failure of the eggs to develop was due to the high temperature.

Schwartz (1932) reported that ova of *Ascaris vitulorum* did not survive exposure on glass slides to 1 hour's direct sunlight in the Philippines. Eggs exposed in beakers of water also failed to survive after 1 hour of direct sunlight. Schwartz then exposed ova in vials painted with India ink to exclude light. An exposure of 1 hour in sunlight was lethal to ova in painted and unpainted vials, and Schwartz thus attributed the death of the ova to the temperature, which reached 45° C.

Ohba's negative results from exposure of ascarid ova to sunlight are difficult to interpret in the light of our irradiation tests, as the length of exposure is not stated in the English summary of Ohba's

paper. Regardless of these negative results, it is apparent from our tests that sunlight, through the ultraviolet spectrum at wave lengths of approximately 3022 Å, does exert a definite radiotoxic effect on ascarid ova. However, owing to the relatively long exposures necessary for the development of this lethal effect, it appears probable from a practical standpoint that other factors, such as desiccation or high temperatures, exert a more destructive action on these ova. In humid, tropical climates, however, ultraviolet light probably does serve in some measure in preventing the development of such ascarid ova as are directly exposed to sunlight.

SUMMARY AND CONCLUSIONS

Irradiation of the ova of *Toxocara canis* and *Toxascaris leonina* at measured wave lengths from a quartz monochromator and quartz mercury⁵ arc resulted in a certain degree of radiotoxicity to the ova exposed at certain wave lengths.

A dosage of 684,000 ergs/cm² at wave lengths of 2652 and 2804 Å had a marked lethal effect on the ova of *Toxascaris leonina* but apparently no effect on the ova of *Toxocara canis*. A similar dosage at wave lengths of 2967, 3022, 3130, and 3650 Å was without effect on the ova of either species.

A dosage of 27,400,000 ergs/cm² at a wave length of 3022 Å resulted in definite radiotoxicity on the ova of both species of ascarids. Exposures to the same dosage at wave lengths of 3130 and 3650 Å showed no effect.

A dosage of 137,000,000 ergs/cm² at a wave length of 3022 Å showed a marked lethal effect on the ova of both species. In the case of *Toxocara*, only 20.5 per cent of the irradiated ova developed to embryonation as compared with 65.5 per cent embryonation in the control culture; only 1.5 per cent of the *Toxascaris* ova reached embryonation as against 42.0 per cent embryonation in the control culture. The dosage employed was approximately equivalent to an exposure of 60 hours noonday, midsummer sun at Washington, D. C., or 12 days of average July sunlight.

In all of these tests, the ova of *Toxascaris leonina* proved more susceptible to the action of ultraviolet light than did the ova of *Toxocara canis*. This difference is probably accounted for by the difference in structure and pigmentation of the shell; the mosaically patterned, mammillated, darkly pigmented shell of *Toxocara* ova would appear to disperse and to absorb more light than does the clear, unmammillated, lightly pigmented shell of *Toxascaris* ova.

Although the marked lethal effect of sunlight on ascarid ova, as reported by several workers, is probably due chiefly to desiccation and high temperatures, it would appear that the ultraviolet spectrum is in itself a factor under certain conditions in the destruction of such ova.

LITERATURE CITED

- BRACKETT, F. S., and McALISTER, E. D.
1932. A spectrophotometric development for biological and photochemical investigations. *Smithsonian Misc. Coll.*, vol. 87, no. 12, pp. 1-7, Sept. 26.
- BROWN, HAROLD W.
1927. Studies on the rates of development and viability of the eggs of *Ascaris lumbricoides* and *Trichuris trichiura* under field conditions. *Journ. Parasitol.*, vol. 14, no. 1, pp. 1-15, Sept.
- CALDWELL, FRED C., and ELFREDA L.
1928. Preliminary report on observations on the development of ova of pig and human *Ascaris* under natural conditions, and studies of factors influencing development. *Journ. Parasitol.*, vol. 14, no. 4, pp. 254-260, June.
- COBLENTZ, W. W., and STAIR, R.
1931. Measurements of extreme ultra-violet solar radiation using a filter method. *Bur. Standards Journ. Res.*, vol. 6, no. 6, pp. 951-976, June.
- HERTEL, E.
1904. Über die Beeinflussung des Organismus durch Licht, speziell durch die chemisch wirksamen Strahlen. *Zeitschr. allg. Physiol.*, vol. 4, pp. 1-43.
- MANALANG, C.
1927. Observations on the development of *Ascaris* ova. *Philippine Journ. Sci.*, vol. 33, no. 3, pp. 249-255, July.
- NOLF, L. O.
1932. Experimental studies on certain factors influencing the development and viability of the ova of the human *Trichuris* as compared with those of the human *Ascaris*. *Amer. Journ. Hyg.*, vol. 16, no. 1, pp. 288-322, July.
- OHBA, T.
1926. On the growth of the eggs of *Ascaris lumbricoides*. *Japanese Journ. Zool.*, vol. 1, no. 4, pp. 121-122, Mar. 31.
- OTTO, G. F.
1929. A study of the moisture requirements of the eggs of the horse, the dog, human and pig ascarids. *Amer. Journ. Hyg.*, vol. 10, no. 2, pp. 521-525, Sept.
- OWEN, WILLIAM B.
1930. Factors that influence the development and survival of the ova of an ascarid roundworm *Toxocara canis* (Werner, 1782) Stiles, 1905, under field conditions. *Univ. Minnesota Agr. Exp. Sta., Techn. Bull.* 71, pp. 1-25, Sept.
- ROSS, RONALD.
1916. The life history of *Ascaris lumbricoides*. (Letter to Editor, dated July 1.) *British Med. Journ.*, vol. 2, no. 2897, pp. 60-61, July 8.

RUPPERT, W.

1924. Empfindlichkeitsänderungen des Ascariseies auf verschiedenen Stadien der Entwicklung gegenüber der Einwirkung ultravioletter Strahlen. Zeitschr. wiss. Zool., vol. 123, no. 1, pp. 103-155, June 2.

SCHLEIP, W.

1923. Die Wirkung des ultravioletten Lichtes auf die morphologischen Bestandteile des Ascariseies. Arch. Zellforsch., vol. 17, no. 3, pp. 289-366, Aug. 10.

SCHWARTZ, BENJAMIN.

1922. Observations on the life history of *Ascaris vitulorum*, a parasite of bovines in the Philippine Islands. Preliminary paper. Philippine Journ. Sci., vol. 20, no. 6, pp. 663-669, June.

SEIDE, JAKOB.

1925. Zur Kenntnis der biologischen Strahlenwirkung. Untersuchungen am Ascaris-Ei mit ultravioletten, Röntgen-und Radiumstrahlen. Zeitschr. wiss. Zool., vol. 124, no. 2, pp. 252-304.

STEVENS, N. M.

1909. The effect of ultra-violet light upon the developing eggs of *Ascaris megalcephala*. Arch. Entwicklungsmech. der Organismen, vol. 27, no. 4, pp. 622-639, June 15.

TSCHACHOTIN, SERGEÏ.

1912. Die mikroskopische Strahlenstich Methode eine Zelloperationsmethode. (Vorläufige Mitteilung.) Biol. Centralbl., vol. 32, no. 10, pp. 623-630, Oct. 20.

SMITHSONIAN MISCELLANEOUS COLLECTIONS
VOLUME 93, NUMBER 2

MUD SHRIMPS OF THE ATLANTIC
COAST OF NORTH AMERICA

(WITH FOUR PLATES)

BY
WALDO L. SCHMITT
Curator, Division of Marine Invertebrates,
U. S. National Museum



(PUBLICATION 3292)

CITY OF WASHINGTON
PUBLISHED BY THE SMITHSONIAN INSTITUTION
FEBRUARY 15, 1935

The Lord Baltimore Press
BALTIMORE, MD., U. S. A.

MUD SHRIMPS OF THE ATLANTIC COAST OF NORTH AMERICA

BY WALDO L. SCHMITT

Curator, Division of Marine Invertebrates, U. S. National Museum

(WITH FOUR PLATES)

Except for the comprehensive and invaluable papers of de Man,¹ and the exceedingly useful, though less exhaustive, account of Borradaile,² there is for American workers no readily available taxonomic information concerning the several species of *Callianassa* occurring on the Atlantic coast of North America. To fill this need in part at least, these brief notes and diagnostic key have been compiled. To render them as complete as possible at this time, it has been found necessary to describe three new species, together with a new variety of one of them, and to propose a new name for a specimen that had been assigned to an old, inadequately described species, which to this day has not been certainly rediscovered:

	Page
<i>Callianassa (Callichirus) islagrande</i>	3, 5
<i>jamaicense</i>	4, 9
<i>jamaicense</i> var. <i>louisianensis</i>	4, 12
<i>rathbunae</i>	4, 15
<i>hartmeyeri</i> , new name for	
<i>Glypturus grandimanus</i> Balss.....	4

It is possible also to report a new record of occurrence in Jamaica for *Callianassa (Callichirus) longiventris*, a species not heretofore seen since the original types were described by A. Milne-Edwards from Martinique.

Moreover, in the light of the studies contributory to this paper, Stimpson's genus *Glypturus* appears no longer tenable, and its unique species therefore reverts to the genus *Callianassa*.

¹ A contribution to the knowledge of twenty-two species and three varieties of the genus *Callianassa* Leach. *Capita Zoologica*, vol. 2, pt. 6, pp. 1-56, pls. 1-12, 1928.

The *Thalassinidae* and *Callianassidae* collected by the Siboga-Expedition with some remarks on the *Laomedidae*. *Siboga-Exped. Monogr.* 39a^o, pp. 1-187, pls. 1-20, 1928.

² On the classification of the *Thalassinidea*. *Ann. Mag. Nat. Hist.*, ser. 7, vol. 12, pp. 534-551, 1903.

A word of appreciation is here extended to some of the students and staff of the Biological Laboratory of the Louisiana State University at Grand Isle, La.; in particular, Dr. Ellinor H. Behre, Director, and William W. Anderson, a student of several summers ago, whose industry first brought to my attention specimens of two undescribed species found at Grand Isle, in the determination of which the other information here presented was brought together. I also wish to thank, among others, Drs. E. A. Andrews, of Johns Hopkins University; C. B. Wilson, of the State Teachers College at Westfield, Mass.; and A. S. Pearse, of Duke University, Durham, N. C. who have contributed specimens of Callianassas to the collections of the United States National Museum.

Three west Atlantic species are not included in the key given below:

(1.) *Callianassa grandimana* Gibbes (Proc. 3d. Meet. Amer. Assoc. Adv. Sci., p. 194, 1850. Type locality, Key West). Many attempts have been made to establish this species, regrettably so briefly described by its author. The species to which it seems to stand nearest is *C. branneri* (Rathbun). Of this latter species I have the greater part of several large specimens taken by Dr. A. S. Pearse on Long Key, Dry Tortugas, Fla., out in the Gulf of Mexico, roughly 60 miles due west of Key West, the type locality of *C. grandimana*, but until we know more of the Callianassas of our southern States we should refrain from making use of Gibbes' specific name. Balss some time ago assigned a specimen from Kingston, Jamaica, to *C. grandimana*, but the very spiny armature of the ventral border of the ischium and merus of the larger cheliped of this specimen definitely precludes any such identity. The ischium of *C. grandimana*, second segment of Gibbes,³ has "distant granules on its lower edge," and the merus, "the third segment [,] is broader, dilated so as to form below a sharp serrated edge, which is truncated as it approaches the posterior articulation." Balss' specimen, moreover, shows a prominently trispinose front; Gibbes says nothing on this score, but I do believe if the front had been different in any marked degree from that of *C. major* he would have made some comment to that effect; his observations, so far as they have been checked, have always been proved accurate. His fault was brevity of descrip-

³ De Man, *Capita Zoologica*, vol. 2, pt. 6, p. 19, 1928, does say that Gibbes did not describe the merus and ischium, but in the very relations of the several joints of the major cheliped as set forth by Gibbes, the second and third joints are none other than those particular joints; the shape ascribed by him to each of them makes their identification unmistakable.

tion. Just recently his *Squilla neglecta*, characterized in remarkably few words, has been found again and recognized without difficulty.⁴ The front of his *grandimana* surely cannot be very different from that of *C. major* or very unlike that of *C. branneri*. That several authors have assumed that *C. grandimana* had a trispinose front seems to be due to a mistaken impression based on Stimpson's passing comparison of the description, not specimens, of Gibbes' species with his *Glypturus acanthochirus*. De Man was well aware that Stimpson, as he says, had never seen the Gibbes species, yet he, too, without any good reason, was moved to consider that it might be related to the trispinose *C. longiventris*. For Balss' species the name of the collector, Dr. R. Hartmeyer, is proposed: *Callianassa hartmeyeri*.

(2.) *Callianassa siguanensis* (Boone). (*Glypturus siguanensis*, Bull. Bingham Oceanogr. Coll., vol. 1, art. 2, p. 85, fig. 17, 1927. Type locality, Siguanea Bay, Isle of Pines.) This species would key out below with *C. branneri* (p. 4, below). For want of evidence other than that given by the author I am inclined to consider it identical with this last-named species.

(3.) *Callianassa occidentalis* Bate (Rept. Challenger Macrura, p. 29, pl. 2, fig. 2k, 1888. Type locality, off Sombrero Island). Only the larger left cheliped is known, so the species (?) cannot be satisfactorily keyed out; moreover, it may even be the cheliped of a larger specimen of the "*Cheramus*" *occidentalis* of the same author noted in the key below (II. A., p. 5), a considerably mutilated specimen lacking the chelipeds.

KEY TO SPECIES OF CALLIANASSA

- I. Telson broader than long, third maxillipeds more or less broad and flattened, especially ischium and merus, and often the propodus too.
 - A. Lateral angles or projections of front not spined.
 - 1. Inner uropods narrow, about four times as long as broad, styliform or straplike; rostral projection low, blunt, or rounded triangular.
 - a. Carpus of larger cheliped more than four times as long as its greatest width; merus with a shallow projection or low granulated tooth on ventral border; ischium with a long, prominent hooked tooth or spine near middle of ventral border. . . . *islagrande*, n. sp.
 - b. Carpus less than three times as long as wide; merus with strong tooth near proximal end of lower border; ischium not known (North Carolina to Florida) *major* Say.⁵

⁴Lunz, G. Robert, Jr., Charleston [S. C.] Museum, Leaflet No. 5, pp. 1-8, 1933.

⁵Journ. Acad. Nat. Sci. Philadelphia, vol. 1, pt. 2, p. 238, 1818; de Man, Capita Zoologica, vol. 2, pt. 6, p. 30; pl. 7, fig. 14-14b; pl. 8, fig. 14c-14d, 1928.

2. Inner uropods wider, either (a) about twice as long as wide or (b) not much longer than wide.
 - a. Inner uropods about twice as long as greatest width; rostrum a conical acuminate spine.
 - i. Merus of larger cheliped armed with a toothlike process near proximal end of ventral border; upper border of carpus about as long or longer than upper border of palm. *jamaicensis*, n. sp.
 - ii. Merus unarmed below; upper border of carpus not exceeding three-fourths the length of upper palmar border (Puerto Rico and Barbados) *marginata* Rathbun.⁶
 - b. Inner uropods not much longer than wide; rostrum low, triangular, subacute, or rounded off.
 - i. Merus of larger cheliped armed with a strong tooth near proximal end of lower border; upper border of carpus three-fourths or more the length of the upper palmar border (Massachusetts to North Carolina) *atlantica* Rathbun.⁷
 - ii. Merus inconspicuously serrate or denticulate, but without strong tooth below; carpus from a half to two-thirds as long as upper border of palm (Brazil, Bermuda, Puerto Rico, Barbados, and the Dry Tortugas, Florida) *branneri* Rathbun.⁸
- B. Frontal margin trispinose.
 1. Both chelae armed with three strong spines above; upper border of carpus three-fourths the length of the palmar border; carpus strongly spined on lower border, merus spined above and below (Florida, Jamaica, Barbados) *acanthochirus* Stimpson.⁹
 2. Chelae not armed with strong spines above.
 - a. Eyestalks flattened, cornea on dorsal surface; merus of larger cheliped multidenticulate below, of minor cheliped unarmed; upper border of carpus of larger cheliped less than half the length of the upper palmar border *rathbunae*, n. sp.
 - b. Eyestalks subcylindrical, cornea terminal or nearly so.
 - i. Merus of large cheliped with more than five spines on ventral border, of minor cheliped unarmed; upper border of major carpus less than half as long as upper palmar border (Martinique and Jamaica) *longiventris* A. M.-Edw.¹⁰
 - ii. Merus of large cheliped with four or less spines below, of minor cheliped with one or two; upper border of major carpus more than half the length of the upper palmar border (Jamaica).
hartmeyerii, new name.¹¹

⁶ Bull. U. S. Fish Comm. for 1900, p. 92, fig. 15a-d, 1901.

⁷ U. S. Nat. Mus. Bull. 138, p. 107, footnote, 1926; *C. stimpsoni* Smith, Rep. U. S. Fish Comm. for 187, p. 549, pl. 2, fig. 8, 1873; de Man, Capita Zoologica, vol. 2, pt. 6, p. 37, pl. 9, figs. 17, 17d, 1928.

⁸ Proc. Washington Acad. Sci., vol. 2, p. 150, pl. 8, figs. 5-8, 1900.

⁹ *Glypturus a.*, Ann. Lyceum Nat. Hist. New York, vol. 10, nos. 4, 5, p. 121, 1871.

¹⁰ Nouv. Arch. Mus. Mem., vol. 6, p. 92, 1870. De Man, Capita Zoologica, vol. 2, pt. 6, p. 24, pl. 6, figs. 12, 12h, 1928.

¹¹ *Glypturus grandimanus* Balss, Zool. Anz., vol. 61, p. 179, 1924.

- II. Telson longer than broad; third maxillipeds narrow; frontal margin without lateral spines; eyestalks flattened, cornea dorsal or lateral; inner uropods less than twice as long as wide.
- A. Telson with a pair of spines on the posterior half of either lateral margin, and a spine at middle of posterior margin; rostrum a little shorter than the eyestalks; chelipeds and external maxillipeds unknown (off Sombrero Island) *batei* Borradaile.¹²
- B. Telson laterally with several spinules, posteriorly unarmed; upper border of carpus less than half as long as upper palmar border; rostrum longer than eyestalks; external maxillipeds narrow (Puerto Rico).
minima Rathbun.¹³

CALLIANASSA (CALLICHRUS) ISLAGRANDE, n. sp.

A distinctive species. Lineae thalassinicae distinct; cervical groove crosses the carapace at nearly one-fourth the length of the carapace from the hinder margin. Rostral projection of front low triangular, extending forward beyond the level of the blunt, inconspicuous lateral projections by about one-fourth or one-fifth its width measured between those projections; the rostrum reaches forward less than one-third the length of the eyestalks, and these in turn reach between one-fourth to one-third the length of the second segment of the antennular peduncle.

The eyestalks are dark brown, with black corneae, and are about twice as long as broad; their terminal one-third to two-fifths are each drawn out into a slender spine slightly curved upward, and with the tip very slightly exerted; inner borders of eyestalks contiguous to about the level of the anterior margins of the corneae; the latter are opposite the distal end of the second segment of the antennal peduncle. Fourth segment of the antennal and second segment of the antennular peduncles reach about equally far forward; fifth or terminal segment of antennal peduncle reaches about two-fifths the length of the distal segment of the antennular peduncle.

Right cheliped of male much the larger; remarkably long and slender, quite the most striking character of this species; the carpus exceeds a little the propodus plus the dactyl, even when the latter is extended straight forward; carpus and palm about equally wide; carpus nearly four and one-half times as long as its greatest width; palm shorter, measured on the upper margin, about three and one-half times

¹² Ann. Mag. Hist., ser. 7, vol. 12, p. 546, 1903. *Cheramus occidentalis* Bate, Rept. Challenger Macrura, p. 32, pl. 2, fig. 1, 1888. *Callianassa batei* de Man, Capita Zoologica, vol. 2, pt. 6, p. 10, pl. 1, fig. 3, 1928.

¹³ Bull. U. S. Fish Comm. for 1900, p. 92, fig. 16a-d, 1901.

as long as wide; merus about four-sevenths the length of carpus; ischium a little longer than merus and about two-thirds the length of carpus.

Ischium granulated with low, rounded, "pearly" granules on both faces, more sparsely on outer than inner faces, forming a denticulated inferior margin; upper margin evenly concave, longitudinally deeply grooved; upper part of outer face of joint, including outer ridge, forming dorsal groove without granules, smooth and shining; inner face of ischium more heavily granulated than outer; just before the middle of its length there is a long, prominent, well-granulated tooth on the lower margin of the ischium, a tooth about as long as the ischium is wide.

Upper margin of merus unevenly and shallowly concave in lateral view; at about the posterior third of its ventral margin is a low granulated tooth, appearing to be made up of sharper, more prominent and more crowded granules than those ornamenting the sides of the ischium; upper border longitudinally grooved like ischium; outer ridge forming groove also very smooth.

The carpus is approximately parallel-margined, though finding its greatest width at about the distal end of the proximal three-sevenths; it is smooth and shining on inner and outer faces but finely denticulate on the upper margin for the greater part of its length, the denticles becoming obsolescent close to its posterior extremity; lower margin of carpus keeled, keel less conspicuous and more or less replaced by rather widely separated denticles or granules in anterior four-sevenths and also obscurely so at the hinder angle.

Palm, like carpus, smooth and shining on lateral faces, upper margin on inside very finely denticulate, lower keeled, keel smooth; on either side of keel there are tufts of long hairs, toward lower edge of palm the hair tufts are roughly alternate on either side of this keel; along the outer side of the keel from proximal end to tip of fixed finger there may be counted about eight tufts, on inner side eleven, the last five of which are more on the "ventral" surface of the finger, for here the keel seems to become less distinct anteriorly and the finger is a bit flattened below on the inner side of the palm; the keel of the lower margin is paralleled by a row of denticles for a little more than its distal half, denticles disappearing on the inner, lower margin of the finger where a blunt keel takes their place; the last hair tuft just below the extreme tip of the movable finger is elongate and more bushy than the other tufts.

The movable finger for the greater part is gently bowed, but at the far end is abruptly hooked; below, it is armed proximally with a

prominent blunt tooth, and anterior to it, with two blunt denticles; distally on the outer, upper border of the terminal hook of the movable finger there is a conspicuous blunt right-angled tooth topped with a thick tuft of hair. This upper, outer tooth on the movable finger makes the digit appear terminally bifurcate; the tooth seems to be a feature characteristic of this species alone; on the upper margin near the base of the tooth is a blunt tuberculiform tooth, and beginning a little distance behind this on the inner side of the upper margin of the finger, a row of low tubercles, about seven in the type; they seem not to be developed in smaller specimens; the fixed finger arises some distance—about half its length—behind the distal margin of the palm and forms with the forward projection of the palm a deep sinus; the fingers, when closed, have a large gape between them, half of which is formed by the sinus just described; the terminal portion of the movable finger closes or hooks outside the tip of the fixed finger.

The smaller cheliped, as compared to the larger, is slight and thin, carpus and propodus together being noticeably shorter than the carpus alone of the larger cheliped; the ischium is fairly straight, unarmed, thin, and flat, a little longer than the merus, shorter than the carpus, and a little shorter than the chela to the tips of the fingers when closed; from its hinder border the carpus narrows anteriorly in lateral aspect, likewise the hand to the tips of the fingers; measured to the tip of the extended movable finger, the hand and carpus are subequal; measured at the middle of its length, the width of the carpus is contained twice in the length of its upper border; the palm, measured from the base of the sinus between the fingers, is longer than wide and longer than the fixed finger measured from the same point, but equal to the movable finger; all joints of the cheliped are smooth and shining; merus and carpus hairy on lower margins, palm thickly so on both margins, fingers on outer surface face adjacent to prehensile edges provided with a thick felt or pad of hairs; prehensile edge of either finger denticulated, armed with about 15 small, sharp, triangular teeth, of which the most anterior are rather small; distal fourth of either prehensile edge or margin more or less without teeth.

The inner face of the ischium of the third maxilliped (pl. 3, fig. 2) shows a short crescentic row of tiny granulations, scarcely to be observed with a glass in a wet specimen; continuing the curve of the crescent formed by not over a dozen of these granulations is a slight ridge, set off by no more than an incised line beside it, which extends about three-fourths the length of the joint.

The abdomen is soft, broad, and depressed; the first two somites are dorsally thin and membranous, the others are thicker and tougher,

symmetrically grooved, and with the exception of the sixth, are ornamented on the epimeral region of either side with a pad or felt of hair.

The telson is about one and one-half times as wide as long, and a little less than half as long as the sixth abdominal somite; the telson and the sixth somite are ornamented with hair tufts about as in *C. major*, but otherwise the two are of very different shape. The telson of *C. islagrande* is truncate or more or less squared-off posteriorly, and but little contracted anteriorly; medially there is a longitudinal, smoothly rounded, raised area, but lower than the inflated lateral portions of the dorsum of the telson, which is bounded laterally by bowed-out, smooth grooves or depressions confluent behind but separating again to pass either side of a rounded, raised area, the pushed-up median portion of the hind border of the telson; the outer uropod is more or less triangular with but gently convex posterior margin, the inner uropod is narrow, tongue- or strap-shaped, distally rounded, and nearly four times as long as wide.

In the useful key given by de Man¹¹ our species would take place alongside of *C. major*, having, like it, very narrow inner uropods, about four times as long as broad, and, to use his expression, almost styliform. However, the different eyestalks, the remarkably elongate larger chela of the male, and the character of the telson sharply differentiate *C. islagrande* from that species.

The females need no separate description; their chelipeds are both much like the minor cheliped of the males.

Type.—U.S.N.M. no. 69362, the largest of 10 specimens (4♂, 6♀) collected by William W. Anderson at Grand Isle, La., in the summer of 1930. It is a male, measuring approximately (in millimeters): carapace 19 long, abdomen 62 exclusive of telson, telson 6 long by 8.5 wide. The larger right cheliped measures: ischium 21, merus 17, carpus 30 (greatest width 6.5), hand on upper margin 19. The extreme forward reach of the movable finger from the articulation to the summit of the tooth on the upper outer margin of the finger measures 10; from articulation to tip this finger measures only 8.5. The smaller, left cheliped measures: ischium 9; merus 8; carpus 11, width at middle 4.8; palm, upper margin 5, width at middle 3.5, lower margin to tip of fixed finger 7.3; movable finger from articulation to tip 6.

I have also seen a lot of 10 females collected by Dr. Ellinor H. Behre at the same place July 5-17, 1928, and a male taken July 15 of the same year by Mr. Anderson.

¹¹ Siboga-Exped. Monogr. 39a⁶, p. iii, 1928.

CALLIANASSA JAMAICENSE, n. sp.

Lineae thalassinicae present; central dorsal "oval" area bounded posteriorly by the cervical groove, and delimited before by a transverse groove behind the rostrum; cervical groove crosses the carapace two-sevenths of the length of the carapace from its hinder margin; the groove crossing the carapace behind the rostrum is about one-seventh the length of the carapace behind the tip of the rostrum; the rostrum extends beyond a line joining the barely marked, obsolescent lateral angles of the front by about half this distance. The rostrum is a stout conical spine reaching about as far forward as the distal margin of the cornea.

The eyestalks are contiguous throughout the extent of their inner margins; on the inner margin just in advance of the centrally placed cornea there is the suggestion of a tubercle reminiscent of the one described by Holmes¹⁵ for his *Lepidophthalmus*, now *Callianassa* (*Callichirus*) *eiseni* from Lower California, a species to which the present one shows kinship, yet from which it may readily be distinguished by the proportions and armature of the major cheliped. The eyestalks of *C. jamaicense* fall a little short of the first segment of the antennular peduncle; the second segment of the antennular peduncle is very little longer than the first measured from the orbital margin of the carapace, and a little short of a third of the length of the third segment; the terminal segment of the antennal peduncle reaches the middle of the last segment of the antennular peduncle, the fourth segment a little past the second of the antennular peduncle, and the second antennal segment and the first or basal antennular segment reach about equally far forward; the antennal scale is represented by a small, inconspicuous spine at the antero-lateral angle of the second segment; the first or basal segment reaches about to the middle of the cornea; as in all these *Callianassas*, the third segment of the antennal peduncle in dorsal view scarcely appears to be more than an articulation between the second and fourth segments of the normally five-segmented peduncle; the third segment is for the most part behind and hidden by the second segment.

The ischium of the larger right cheliped is nearly equal to the upper border of the palm in length and a little (about one-fifth) shorter than the merus; upper border of merus a little longer than that of carpus; merus about one and three-fourths times as long as its median width; carpus at middle of its length about as wide as length of upper border;

¹⁵ Proc. California Acad. Sci., ser. 3, Zool., vol. 3, no. 12, p. 311, pl. 35, figs. 6-13, 1904.

median width of palm and carpus equal; fixed finger measured from the sinus at its base is three-fourths the length of the palm measured back from the same point; it is fairly long and ends in a stout conical subacute tip, and a very low triangular tooth is situated about the middle of its length.

The movable finger is nearly a third longer than the fixed one and armed with three stout conical teeth, a blunt one near the base tending to fit into a notch at the upper end of the base of the sinus between the fingers; the second and larger of the other two more pointed teeth is placed just before the middle of the finger, and the third and smallest is located about one-third the distance from the second tooth to the tip; the upper border of the movable finger is smoothly rounded off, but toward the articulation is somewhat eroded-looking, two short grooves and several pits appearing here; there is a low, conical, inconspicuous tubercle, and perhaps a second lower one adjacent to it, just before the articulation; the fingers cross in such a way that the tip of the fixed one closes between the anterior of the three teeth of the movable finger and its hooked tip, and the two conical teeth of the upper finger bite just before the triangular tooth of the lower margin.

On the outer face of the palm, more or less continuing the line of the outer edge of the prehensile margin of the fixed finger back on to the palm, is a well-marked, curved carina extending back nearly half the length of the palm; above this carina is a low, depressed, triangular area; the anterior margin of the palm is armed with two blunt, forwardly directed teeth, one forming the outer side of the notch at the upper end of the base of the sinus between the fingers and the second placed laterally just below the articulation of the movable finger. Lower border of the palm and movable finger somewhat cristate and obscurely and bluntly serrate, rather, one might say, undulate, owing to the insertion of hair tufts found there; above the palm is more or less carinate in its posterior two-thirds. The carpus is cristate above and below, the anterior dorsal and ventral angles forming each a compressed triangular tooth.

All joints are smooth and shining. The merus shows a blunt longitudinal ridge on the outer face; the infero-proximal angle of this joint is armed with a conspicuous, angled lobe or toothlike process ending primarily in a stout, elongate, conical spine, on the inner hinder side of which is a secondary, smaller, and somewhat curved spine; the laminate lower margin of this joint is seven-toothed in its anterior two-thirds, the first two flattened, the second of these obscurely doubled, the following five placed on the anterior curve of the lower margin more tuberculiform, though compressed; the upper margin

of the merus is interrupted close to the posterior end by a conspicuous narrow U-shaped notch, at the upper extremities of which the dorsal margin of the joint forms a blunt tubercle.

The ventral margin of the ischium is, beginning near the hinder end, finely and for the greater part rather evenly denticulate, the denticles, however, gradually increasing in size anteriorly, the last two or three being larger, the last of these very large comparatively, and forming rather a tuberculiform tooth almost half a millimeter long and distally obscurely bilobed; in advance of this tooth the lower margin is blunt-ridged; above on the outer face, and shorter than the denticulated portion of the lower margin of the ischium, is an obscure, blunt ridge.

When both chelipeds are moderately extended to about the same degree, the fingers of the smaller reach scarcely half their length beyond the distal margin of the carpus of the larger. The ischium is about as long as the merus and a little longer than the carpus or upper margin of palm, but only four-sevenths the length of the movable finger. The upper margin of the dactylus is ridged and grooved, the prehensile edges of both fingers are wide and somewhat hollowed out and the movable one is furnished with two anteriorly converging lines of obscure, small tubercles; the extreme tips are somewhat abruptly constricted to form conical spinous tips so that there is apparently a blunt tooth at the anterior extremity of the outer moiety of each fairly broad prehensile edge; when closed, the tips of the finger reach about equally far forward; there is a sizable gape between them. The palm is rounded above, cristate below, except on the distal half of the fixed finger, carpus blunt above, cristate below, superior and inferior distal angles subacute, merus blunt-ridged above and below; ischium blunt above, with finely denticulate margin below; the ischium and merus are about of the same length measured on the upper border, either a little longer than the carpus, about one-third longer than the upper border of the palm, and a little less than two-thirds the length of the movable finger.

The inner face of the ischium of the third maxilliped (pl. 2, fig. 8) carries a smooth, blunt, yet well-formed, carina wholly without spinous armature, or tiny scalelike excrescences.

Telson somewhat rectangular, about one and one-third times as long as wide, little less than half as long as the sixth somite. Posterior margin three-lobed, shallow, median lobe occupying more than one-third of the posterior margin, and the gently curved lateral angles carried evenly and smoothly around to their respective sides to merge with lateral margins of the telson; dorsal surface evenly convex in both directions; across the dorsum of the telson a little way before the

base is a fine, sharply impressed line occupying more than half the total width of the telson. Inner uropod narrow, a shade more than twice as long as its greatest width measured on, and at right angles to, the median axis drawn from articulation to apex of the blade. Basal joint of uropod armed with a sharp, stout spine; there is a similar but even longer spine near the proximal end of the inner border of the outer uropod, forming with the blade a notch into which the outer margin of the inner blade snugly fits.

Holotype.—U.S.N.M. no. 69363, male, taken from a brackish pond at Montego Bay, Jamaica, by C. B. Wilson, June 29, 1910. It measures (in millimeters) approximately 73 long, tip of rostrum to end of telson; somewhat broken carapace about $18 \pm$, abdomen and telson 55, telson 6 long by 7.5 wide. Large chela, lower border of palm to tip of fixed finger 21, upper border 13.5, dactylus 12.5, width of palm at middle of length 12.5, upper border of carpus 12.5, width 12.5, upper border of merus 13.7, ischium 11. Small chela, lower border of palm to tip of fixed finger 16, upper border 6.1, dactylus 12.5, width 8.3, carpus 7.2 long, width at middle of length 6.3, length of merus 8, ischium 8.

A smaller specimen of about 61 mm in length, also from Montego Bay, taken on June 24 of the same year by Dr. E. A. Andrews, likewise from a salt-water pond, is like the type in all particulars, except in the ventral armature of the merus of the large cheliped, which is five-instead of seven-toothed toward the distal end of the joint. The fine, sharply impressed line across the midportion of the base of the telson is present, but does not extend as far to either side as in the type.

CALLIANASSA JAMAICENSE var. **LOUISIANENSIS**, n. var.

From Grand Isle, La., comes another specimen very similar to the preceding, which I should almost have been tempted to describe as a distinct species but for the fact that its larger right hand shows some evidence, though slight, of having been injured. For the present at least it had best be considered as no more than a varietal form. There is only a single male specimen taken by Chenier Ronaville, July 18, 1928.

Type.—U.S.N.M. no. 69364. The description of the type of the species proper as regards carapace, rostrum, and frontal appendages, about fits the variety; the eyestalks, however, have a very pronounced tubercle on the inner margin, whereas only a suggestion of one was to be seen in the type of the species. It was only mentioned in connection with the type, because a very definite though small tubercle is

visible in the only other specimen of the typical species at hand, also from Montego Bay, Jamaica.

The major right cheliped does not differ much from that in the typical species in the proportions of its joints and their armature except in the fingers; merus and carpus about subequal, measured on their upper borders; merus about twice as long as its median width; fixed finger from hind end of sinus between the fingers is one-half the length of the palm measured back from the same point. The fixed finger is short and strong and ends in a stout, conical, up-turned extremity and has a strong, blunt, tuberculiform tooth situated at about one-third the length of the finger from the back of the sinus between the fingers to the tip. The movable finger had the tip broken off before capture and may have lost from a tenth to a fifth of its length, the part remaining slightly exceeding in length the fixed finger. On the cutting edge it is provided with two teeth, a stout conical one near the base of the finger tending to fit into a notch at the upper end of the base of the sinus between the fingers, and an anterior longitudinally elongated laminate tooth; these teeth are so spaced that the tooth on the fixed finger bites between them, while the tip of the fixed finger closes in advance of the laminate tooth of the movable finger; on the upper margin of the movable finger is a single blunt tubercle, more conspicuous than either of the tubercles similarly placed in the type of the species; also in the variety the finger is smooth above and not eroded toward the articulation; in the second of the typical specimens the finger, again, is eroded and the tubercle inconspicuous.

Near the hinder end of the carina forming the posterior two-thirds of the upper border of the palm there is a brief emargination, followed by a small tooth; that this effect may have been brought about by an injury is possible; the conspicuous carina on the outer face of the palm of the type of the species is here represented by an inconspicuous impressed line perhaps two-sevenths the length of the palm in line behind it; no depressed area is evident above this line.

The antero-inferior angle of the carpus shows two tiny tuberculiform projections, one either side of a hair tuft at that angle.

The ventral margin of the merus, other than the two-spined lobe at the posterior end, as in the type of the species, is unarmed except for three compressed teeth near the anterior end of the middle third of the margin; the merus of the smaller of the two typical specimens closely resembles that of the varietal form, though it has five teeth in place of the three just mentioned. Posteriorly, the upper margin of the merus has a shallow emargination in place of the very definite notch found in the typical specimens. The tooth at the anterior end of

the denticulations arming the ventral margin of the ischium is larger than that in the type of the typical species, being nearly half a millimeter long.

The smaller cheliped is not much different from that of the type of the species proper, the fingers are more slender and the hand more triangular; the tip of the movable finger is also wanting.

The smooth, blunt ridge on the inner face of the ischium of the third maxilliped (pl. 2, fig. 7) appears unarmed or unadorned; only by careful inspection, and then with a glass, can five little scales or tiny, scarcely perceptible, well-separated, flattened spines be observed in line on the proximal third of the ridge.

Next to the differences from the typical specimens in the large chela and fingers, those found in the telson and the uropods are the most marked. The telson is even more rectangular-appearing than that of the type of the species, as the lateral angles are not so broadly rounded and the hinder margin is more truncate or straight; it is, however, like that type in being about one and one-third times as wide as long, and contained in the length of the sixth abdominal somite about twice; the telson is transversely evenly, though shallowly, convex, flatter than in the typical species, but unlike it, has the median longitudinal convexity interrupted by a not inconspicuous depression just before the hinder margin; the inner uropod measured as in the type of the species proper is but one and one-half times as long as wide; the basal segment of the uropods is armed with a low, blunt, triangular spine, and in place of the conspicuous spine on the proximal margin of the outer blade of the typical specimens there is an inconspicuous, low tubercle; no fine impressed line appears across the middorsal region of the telson parallel to and a little before the basal margin; there is a short, not at all well-marked, shallow, transverse depression on either side of the midline, but not crossing it; these two inconspicuous depressions are well separated from one another transversely and are in no way like the very definite fine line of either of the typical specimens, which very distinctly crosses the middorsal line of the telson.

The differences are such as one might expect, in part at least, between male and female specimens, but I can find no evidence that any of the specimens are female. True enough, the type retains but one basally much mutilated third leg, but there are in the other two specimens no traces of external female apertures, and the first pleopods of all three are of the same masculine character.

This varietal specimen measures (in millimeters) approximately 68 long, carapace and rostrum 16, abdomen and telson about 52; telson alone about 4.9 long by a shade over 6 wide. The large chela, measured

on lower border to tip of fixed finger, is 15.5 long; upper border of palm to articulation of dactylus 10, broken dactylus 7.7, width of palm at middle of length 11, length of upper border of carpus, as well as width, 11, upper border of merus 10.3, ischium 8.6. Small chela, movable finger 10, upper border of palm 4.3, width 6.5, lower border to tip of fixed finger 12, carpus 5.7, width at middle of its length the same, merus 6, ischium 6.5.

Remarks.—In giving a name to this proposed new variety, I am reminded of the varietal form that de Man¹⁶ has indicated for Borradaile's *C. (Callichirus) novae britanniae*, and again of his discussion¹⁷ of *C. (Tryphaea) californiensis* var. *japonica* Bouvier and *C. (T.) japonica* (Ortmann) and his *C. (Callichirus) longiventris* var. *borradailei*.¹⁸ I believe the specimen worthy of varietal designation until such time as additional material may call for a change of opinion.

CALLIANASSA (CALLICHIRUS) RATHEUNAE, n. sp.

With tridentate front and the "oval" area before the cervical groove scarcely delimited from the front, although a very faintly indicated groove crosses the anterior part of the carapace at a distance behind the orbital margin about equal to the length of the rostrum; laterally, this faint groove trends backward and downward toward the linea thalassinica on either side but does not join either it or the cervical groove behind. The cervical groove is deep and crosses the dorsum of the carapace about two-sevenths of the length of the carapace in advance of its hinder margin. The rostrum is a slender short spine reaching about one-half the length of the contiguous portions of the inner margin of the eyestalk. The latter are in contact for about two-thirds of their length, flaring in the anterior third widely outward to terminate each in a little pointed tubercle at the juncture of the inner border of the eyestalk and the gently incurved outer border in front of the cornea. This tubercle lies in line with the midpoint or center of the cornea and about the length of the corneal diameter in front of it. The corneae are light brown and occupy the outer two-fifths of the width of the stalk and approximately the fourth and fifth sevenths of the length of the stalk.

The eyestalks just overlap the distal margin of the basal segments of the antennular peduncle; thus the first segment of this peduncle is not visible except for a small portion either side of the eyestalks;

¹⁶ *Capita Zoologica*, vol. 2, pt. 6, p. 49, 1928.

¹⁷ *Idem*, pp. 18, 19.

¹⁸ *Idem*, p. 27.

the second segment of the peduncle is about four-sevenths the length of the first, and in turn three-fifths the length of the terminal segment. The second segment of the antennal peduncle on the right side reaches about as far forward as the basal segment of the antennular peduncle; the fourth segment reaches nearly to the distal margin of the terminal segment of the antennular peduncle; the terminal segments of both peduncles are nearly subequal in length and each about two-thirds the length of the fourth segment of the antennal peduncle; the antennal peduncle of the left side seems to be placed lower, as the distal margins of its several segments each fall short in turn of the forward distance attained by the segments of the extended peduncle on the right side. The lateral frontal spines are slender, sharp, incurved, and to some degree movable, as they are joined to the front by a somewhat flexible noncalcified extension of the carapace; they lie just without the line of the inner margin of the antennal peduncles. The lineae thalassinicae diverge more widely anteriorly than posteriorly, and so at the front the "oval" area which they appear laterally to limit seems much wider there than posteriorly, thus giving the dorsum of the carapace of this species an inverted wedge-shaped look unlike the other species described in this paper.

The large left cheliped has a very short carpus, which is a little short of being twice as high as long. Measured on the upper border, the palm is very slightly longer than the merus, and a very little shorter than the movable finger, about twice the length of the carpus and about one-fifth longer than the ischium; the palm is about as wide at its midpoint as the upper border is long. The ischium is armed beneath the anterior end with three moderately long, slender spines, toward the posterior end also with three more widely spaced, much smaller, slender ones, and at a point midway between the two groups there is a single spine of intermediate length; all of the spines are directed forward, as are those arming the lower border of the merus; on the latter are to be counted 12, which get smaller anteriorly, with the exception of the second spine, close by the first one, which seems smaller than it should be, perhaps abnormally so. The carpus and chela are smooth and shining; the upper and lower margins of the former are thin, laminate, and turned over to form a serrate edge above and below; in the case of the carpus for the greater part of the hinder margin this serrate edge is so turned over as not to be visible in the outer, lateral view of the cheliped, except for the most anterior two or three serrations at the infero-distal angle; the upper and lower margins of the palm are cristate and also serrate, but the serrations are not so much turned at right angles to the perpendicular as in the

carpus, for, although the dorsal serrations are scarcely visible from the side, the ventral ones are plainly so; the latter run forward only about half the length of the ventral border of the fixed finger. The prehensile edge of the dactylus has two elongate, not very prominent, laminate teeth, the fixed finger a single low triangular, more or less inconspicuous one a little behind the middle of its length. In the smaller chela the ischium is very little longer than the merus, subequal to the carpus, and nearly a third longer than the upper border of the palm; the movable finger is a little longer than the palm above. The greatest width of the carpus is contained about twice in its length, and equal in width to the palm; the width of the latter is contained in its upper border about one and one-third times.

On the inner surface of the ischium of the third maxilliped (pl. 3, fig. 1) there is a curved row of 17 teeth, of which the proximal 7 are strong, acute spines, and the remainder on the distal moiety of the comb are dentiform rather than spiniform.

Telson truncate, hinder margin slightly scalloped, a little less than one-half the length of the sixth somite and about four-fifths as long as its greatest width; inner uropod longer than the telson, but shorter than the outer uropod, broadly triangular; outer blades but weakly sculptured. Somites of the abdomen remarkably smooth and without ornamentation.

Type.—U.S.N.M. no. 23010, the larger of two male specimens in the collections of the National Museum, both from Bluefields, Jamaica, where they had been washed up after a storm in the summer of 1899. It measures (in millimeters): carapace and rostrum 18 long, abdomen and telson together 43, telson 5.3 by 6.7 wide; large cheliped, ischium 10 long, merus 11, carpus 6.5 long, greatest width 10.5, palm, upper border 12 long, movable finger 12, lower border 22.2, width of palm at middle of length 11. Small chela has the ischium 8.3 long, merus 7.7, carpus 9 by 4 wide, palm, upper border 6, movable finger 6.8, lower border, including fixed finger, 12.0, width of palm at middle of length 4.3

CALLIANASSA (CALLICHIRUS) LONGIVENTRIS A. M.-Edw.

Callianassa longiventris A. Milne-Edwards, Nouv. Arch. Mus. Mem., vol. 6, p. 92, 1870.

Callianassa (Callichirus) longiventris de Man, Capita Zoologica, vol. 2, pt. 6, p. 24, figs. 12, 12 h, 1928.

From the bathing beach at Montego Bay, Jamaica, Dr. E. A. Andrews, of Johns Hopkins University, took two specimens of a

Callianassa, one of which regrettably lacks the larger chelipeds, for both represent an exceedingly rare species known heretofore only from the type lot of four described in 1870 by A. Milne-Edwards, from Martinique.

A comparison with the detailed description given by de Man for one of the specimens of the type lot reveals certain small differences, mention of which might not be out of place here.

The rostrum is longer, extending about as far forward as the tubercles tipping the eyestalks; the acuminate, lateral spines of the front reach about as far forward as the corneae and so are longer, too, than those of the type.

I should say that the eyestalks are subcylindrical, though they appear in dorsal view to be more or less cylindrical; the corneae are rounded, bulged-up prominences on the anterior dorsal surface of the transversely convex stalks; the patches of dark pigment are concentrated within in the median, posterior halves of the corneae.

The first and third segment of the antennular peduncle are about subequal, each a little longer than the second segment. The terminal segment of the antennular peduncle exceeds the corresponding segment of the antennular peduncle by about three-fourths its length; the fourth or penultimate segment reaches about two-thirds the length of the second segment of the antennular peduncle; while the distal dorsal margin of the third, which is about all that is visible of it from above, about attains the distal margin of the basal segment of the antennular peduncle.

The telson is rather angulated, posterior margin rather straight with the triangular median prominence well marked; medially, in the anterior half above, there is a small, smooth and shining, more or less semicircular raised area from which the telson falls away to its margins; two obscure ridges run back to the postero-lateral angles of the telson; on the posterior margin just inside either of these angles is a tuft of long hair; the hinder margin of the raised area on the dorsum of the telson is also furnished with a pair of these hair tufts.

The larger cheliped, as in the type described by de Man, is also on the left side; of the ventral ischial spines, the last is the larger, and so it seems to be also in the drawing that de Man gives of this joint; on the lower border of the merus there are but three instead of four spines, the first the smallest, the third larger and more forwardly directed than the others; these three, moreover, are all placed close

together at the infero-posterior angle of the joint and not so placed as to occupy the greater portion of the ventral margin as shown in the picture of the variety figured by Borradaile¹⁹ and referred to by de Man. Measurements (in millimeters) are as follows: carpus on the upper border 6 long and 8 broad at the distal margin; palm 11.5 on the upper margin, 9 broad at the middle, and 17.5 on the ventral margin to the tip of the fixed finger; movable finger from articulation to tip 9 long. The distal border of the palm is distinctly crenulate and, as in the type, is separated by a minute triangular incision from a low triangular tooth which, in the case of our specimen, has its apex at about a fourth of the length of the cutting edge of the finger from the small triangular notch at the base to the tip; the cutting edges of both fingers are sharply cristate throughout, biting so as to about impinge on the "crown" of the tooth of the fixed finger; there is a low, not very conspicuous, triangular tooth on the movable finger.

In the smaller cheliped, the ischium is armed below with 10 instead of 7 spines; the merus has a spine as in the type; it is here placed on the inferior margin at the end of the first third, but, unlike the type, shows a second spine midway between it and the infero-posterior angle of the merus; of this spine the distal half has been broken off, apparently before capture. Measurements (in millimeters) are as follows: carpus 6 long and 5.7 wide at the distal end; upper border of the palm 7 long, the lower to the tip of the fixed finger 14, width at middle 6; the distal margin of the palm is crenulate, but not so distinctly so as in the larger chela, the fingers are armed much as are those of the larger hand; the movable finger is about 8.8 long.

The comb on the inner surface of the ischium of the third maxilliped (pl. 3, fig. 3) is armed, in the distal half with 12 to 15 small sharp spinuliform teeth, followed in its proximal portion by three large, strong, rather widely separated spines.

Of this more complete specimen, a male, the carapace and rostrum together are about 20.7 long, the abdomen and telson together approximately 63; telson is about 6.2 wide at base by 5.8 long. The specimen without chelipeds is a female, a little larger in size, measuring not less than 88 from tip of rostrum to end of the telson.

¹⁹ The fauna and geography of the Maldivic and Laccadive Archipelagoes, vol. 2, pt. 3, p. 752, pl. 58, fig. 2, 2b, 1904.

CALLIANASSA (CALLICHIRUS) ACANTHOCHIRUS STIMPSON

Glypturus acanthochirus Stimpson, Proc. Chicago Acad. Sci., vol. 1, p. 46, 1866; Ann. Lyc. Nat. Hist. New York, vol. 10, p. 121, 1871; de Man, Siboga-Exped., monogr. 39a⁶, p. 19, 25, 180, 1928.

De Man has already intimated that *Glypturus* as a genus is perhaps not distinct from *Callianassa*. His point is well taken, for any examination of the subgenus *Callichirus* will show a number of species that have third maxillipeds approaching, if they do not actually possess, the *Glypturus* type of external maxilliped. The generic character given by Stimpson and based on these appendages, "ischium armed along the middle of its inner [face, instead of edge as Stimpson has it—surely a slip of the pen] with a sharp, prominent, spinous crest," is common to the majority of the species of *Callianassa*; as are the "deeply sculptured caudal lamellae," to a number of the representatives of the subgenus *Callichirus*. Little needs otherwise to be said of this well-characterized and easily recognizable species. The opportunity is here taken (pls. 1-4) of supplying some photographic details of a male specimen of the species. On the distal half of the inner face of the ischium of the third maxilliped (pl. 3, fig. 4) is a comb of 10 spinous teeth of irregular size, but roughly, more or less alternately large and small; near the proximal margin of the joint and continuing the line of the comb are four large and one much smaller dentiform tubercles.

EXPLANATION OF PLATES

PLATE 1

- FIG. 1. *Callianassa jamaicense*, ♂, carapace and frontal appendages, \times about $2\frac{1}{2}$.
 2. *C. jamaicense* var. *louisianensis*, ♂, same.
 3. *C. islagrande*, ♂, same.
 4. *C. longiventris*, ♂, same.
 5. *C. rathbunae*, ♂, same.
 6. *C. acanthochirus*, ♂, same.

PLATE 2

- FIG. 1. *Callianassa islagrande*, ♂, chelipeds, \times $\frac{4}{3}$.
 2. *C. rathbunae*, ♂, same.
 3. *C. longiventris*, ♂, same.
 4. *C. jamaicense* var. *louisianensis*, ♂, same.
 5. *C. acanthochirus*, ♂, same.
 6. *C. jamaicense*, ♂, same.
 7. *C. jamaicense* var. *louisianensis*, ♂. *a, d*, inner and outer faces of third maxilliped; *b, c*, inner and outer aspects of third leg, \times about $2\frac{1}{2}$.
 8. *C. jamaicense*, ♂. *a, d*, inner and outer faces of third maxilliped; *b, c*, inner and outer aspects of third leg, \times about $2\frac{1}{2}$.

PLATE 3

- FIG. 1. *Callianassa rathbunae*, ♂. *a, d*, outer and inner aspects of third leg; *b, c*, outer and inner faces of third maxilliped, \times about $2\frac{1}{4}$.
2. *C. islagrande*, ♂. *a, d*, inner and outer faces of third maxilliped; *b, c*, inner and outer aspects of third leg, \times about $2\frac{1}{4}$.
3. *C. longiventris*, ♂. *a, d*, inner and outer faces of third maxilliped; *b, c*, inner and outer aspects of third leg, \times about $2\frac{1}{4}$.
4. *C. acanthochirus*, ♂. *a, d*, inner and outer faces of third maxilliped; *b, c*, inner and outer aspects of third leg, \times about $2\frac{1}{4}$.

PLATE 4

- FIG. 1. *Callianassa jamaicensis*, ♂, telson, dorsal view \times about $2\frac{1}{4}$.
2. *C. rathbunae*, ♂, same.
3. *C. longiventris*, ♂, same.
4. *C. jamaicensis* var. *louisianensis*, ♂, same.
5. *C. islagrande*, ♂, same.
6. *C. acanthochirus*, ♂, same.

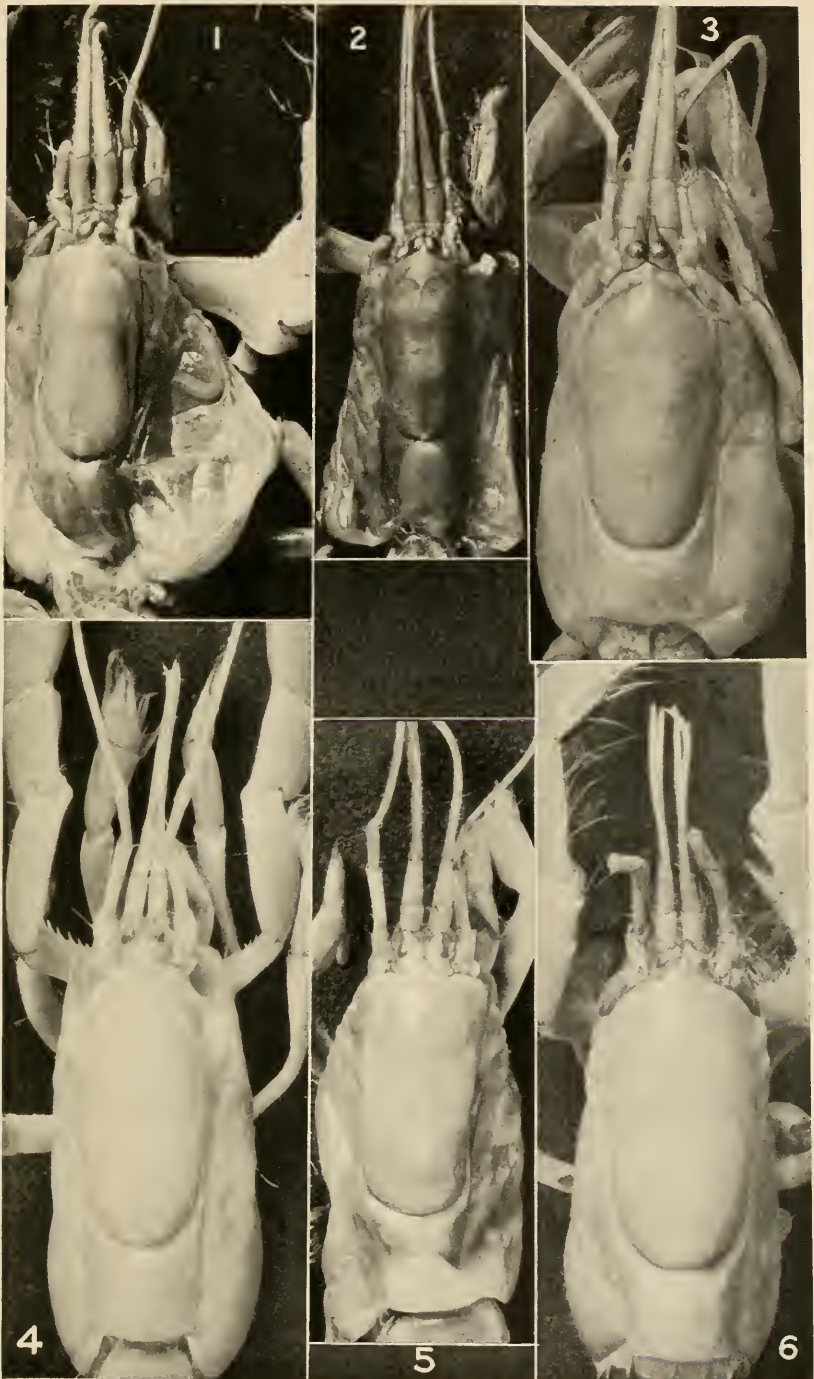

MUD SHRIMPS OF THE GENUS *CALLINANASSA*

(For explanation, see page 20.)

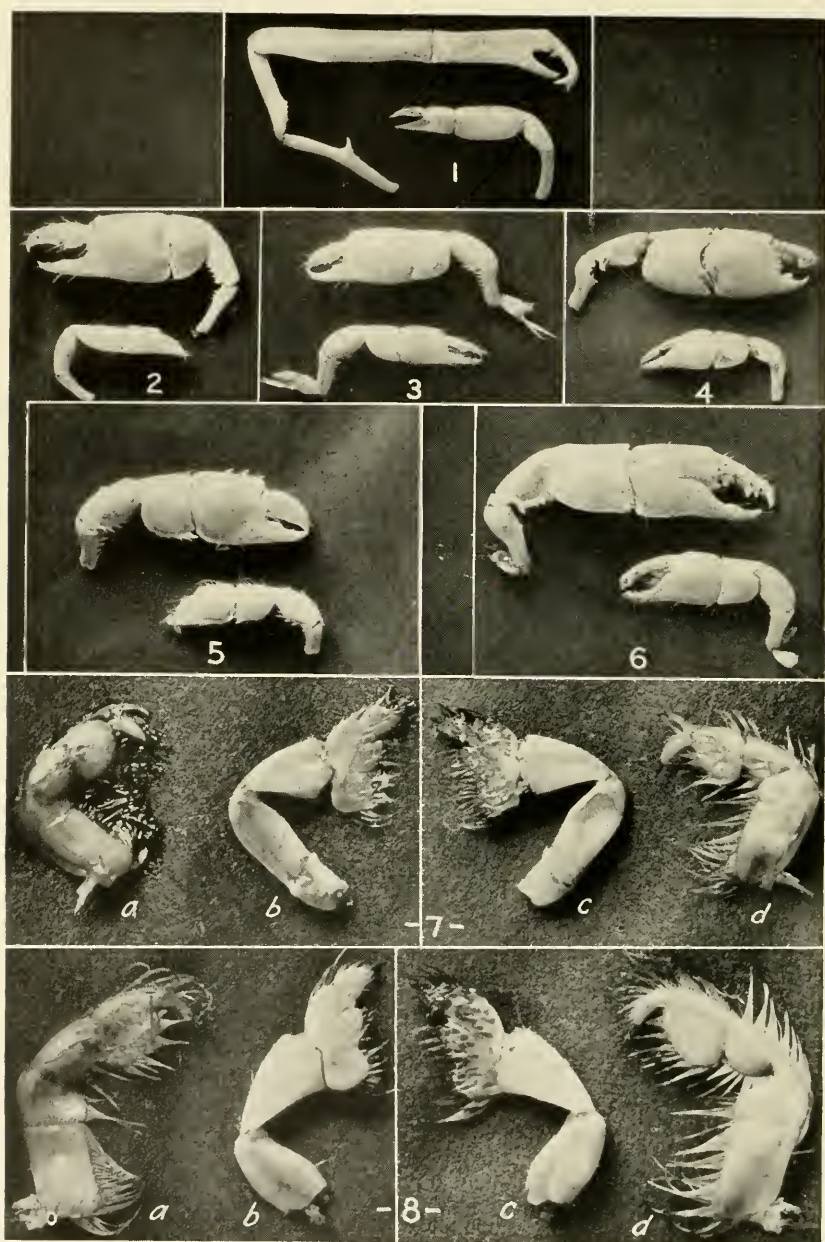

MUD SHRIMPS OF THE GENUS *CALLIANASSA*
 (For explanation, see page 20.)

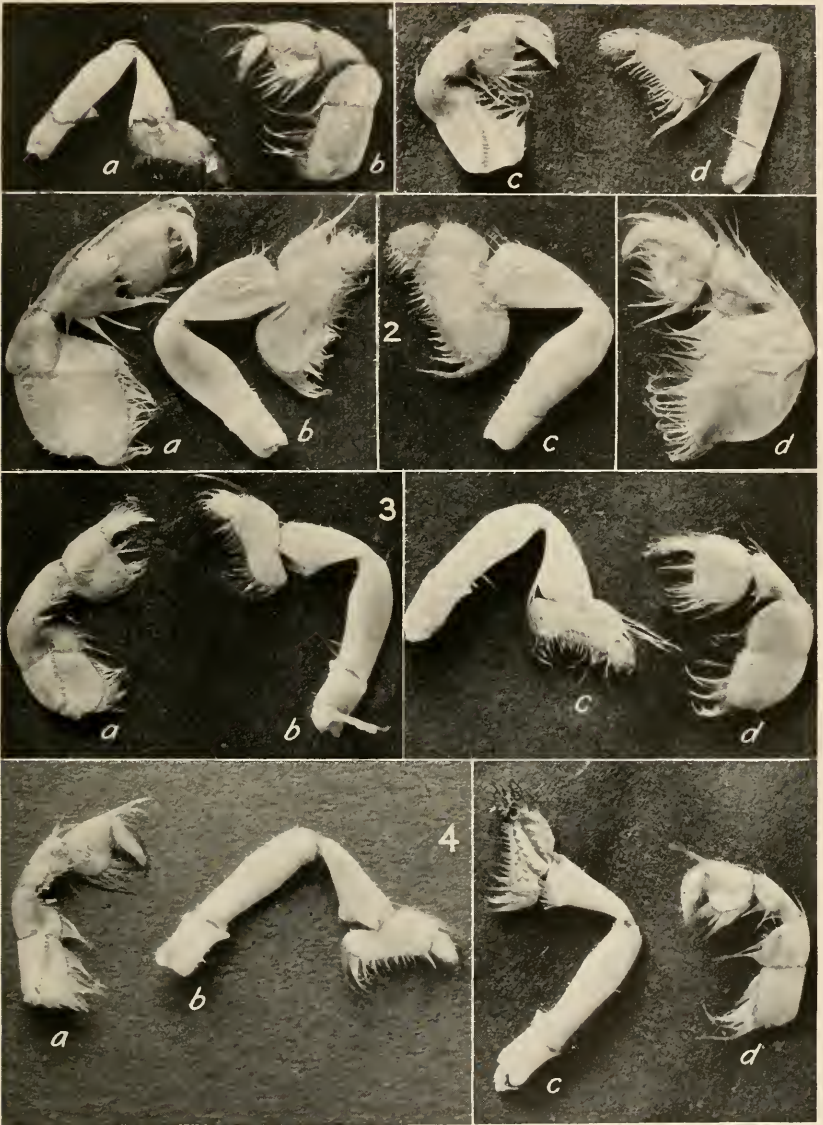

MUD SHRIMPS OF THE GENUS *CALLIANASSA*
(For explanation, see page 21.)

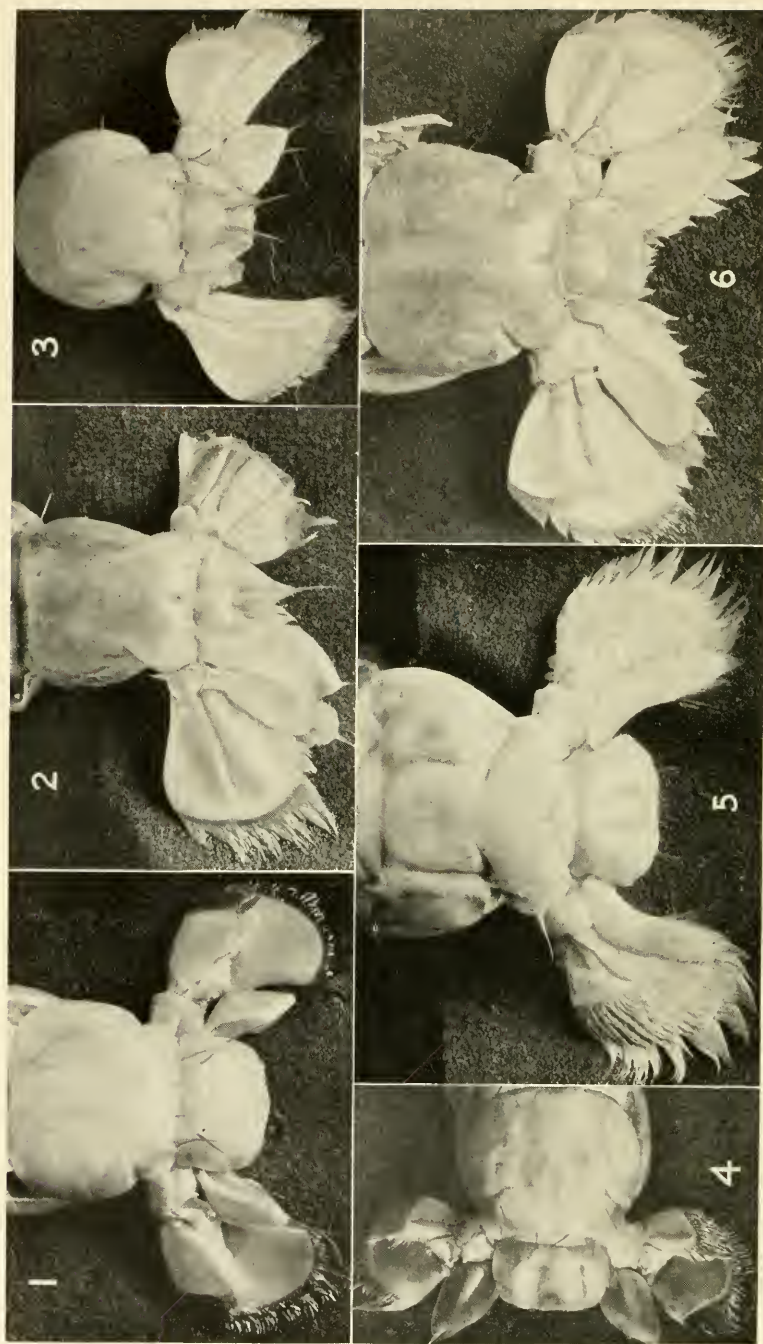

MUD SHRIMPS OF THE GENUS *CALLIANASSA*

(For explanation, see page 21.)

SMITHSONIAN MISCELLANEOUS COLLECTIONS

VOLUME 93, NUMBER 3

NEW EARTHWORMS FROM CHINA, WITH NOTES ON THE
SYNONYMY OF SOME CHINESE SPECIES OF
DRAWIDA AND PHERETIMA

BY

G. E. GATES

Judson College, Rangoon, Burma



(PUBLICATION 3293)

CITY OF WASHINGTON
PUBLISHED BY THE SMITHSONIAN INSTITUTION
FEBRUARY 27, 1935

The Lord Baltimore Press
BALTIMORE, MD., U. S. A.

NEW EARTHWORMS FROM CHINA, WITH NOTES ON
THE SYNONYMY OF SOME CHINESE SPECIES
OF DRAWIDA AND PHERETIMA

By G. E. GATES

Judson College, Rangoon, Burma

Seven years and more ago the author undertook a study of the earthworms collected in the province of Szechuan, China, by Dr. D. C. Graham for the United States National Museum. As many of the Chinese species were inadequately characterized, completion of the report on this study had to be delayed until the gaps in our knowledge of the older forms could be filled out. In the meantime further collections made by Dr. Graham necessitated numerous changes in the earlier manuscript. Just recently opportunities have arisen to examine the types of many important species. As the types of the few remaining species are not likely to be available for examination in the immediate future, the report was brought to completion. As publication of the full report may be delayed for some time, owing to financial conditions, it seems desirable to publish diagnoses of the new species together with short notes on the changes in the synonymy. Full descriptions of the types of the new species, together with some account of the examinations of the older types, as well as explanations of the changes in the synonymy will be included in the definitive report.

In connection with a few of the species the opportunity has been taken to include brief remarks on a very recent paper by Chen (1933), published after the writer's longer paper was completed.

DRAWIDA Michaelsen

The clitellum, in this genus, appears to be a rather evanescent structure, often absent in most, if not all, of the specimens submitted to the systematist for examination, and possibly present or recognizable externally during only a small portion of the year. In these circumstances many of the species in this genus have been erected on aclitellate specimens.

Unfortunately, some of the types have been so juvenile that distinguishing specific characteristics are entirely unrecognizable, and

other types are so immature that there is doubt as to whether the structures of most importance for taxonomic purposes have reached a definitive stage in their development.

Criteria for the recognition of sexual maturity in the genus *Drawida* are therefore essential. Size (of the specimen) is not a satisfactory criterion: a worm 30 mm long may be fully mature, whereas other worms well over 100 mm in length may be too small to identify. Other criteria that might be suggested have proved unsatisfactory, but for most taxonomic purposes sexual maturity may be regarded as evidenced by the distension of ovarian segments or chambers and ovisacs by free ova, the distension of the testis sacs by testicular material, and the distension of the spermathecal ampullae by a flocculent, whitish material.

Especial attention is necessary, in identifications and specific descriptions, to the characteristics and contents of invaginations at the ectal ends of the male deferent apparatus and of the spermathecae, to the central body of the prostate, to the spermathecal atria, and to the glands of the genital markings and the male porophores. The extent of the closing off of the ovarian segment is also to be determined.

DRAWIDA GISTI Michaelsen, 1931

Distinguished from *D. hehoensis* Stephenson, 1924, by the greater size of the prostates and their relation to the penis pouches, greater length of the penes, larger size of the spermathecal atria, incompleteness of closure of the ovarian chamber, presence of an "urn-shaped" gland in the atrial wall, and by the definite genital markings with their glands projecting through the parietes into the coelom.

D. gisti f. *typica* Chen, 1933, differs from the types as follows: apertures of the penial chambers located in *bc* nearer to *c* than *b*, prostates shorter, 4 to 8 mm in length (including duct) rather than 9 to 11 mm, presence of a genital marking in the penis pouch. These differences may or may not be significant.

D. gisti var. *nanchangiana* Chen, 1933, differs from the types as follows: prostates smaller (2 to 2½ mm in length), relation of prostates to the penial chambers, minute size of the spermathecal atria, and "ventrally closer and more prominent setae". According to Chen the spermathecal atrium is "often minute, bulb-like embedded in body wall, rarely elongate like other varieties". Specimens with minute atria embedded in the body wall may, of course, be juvenile, but if sexually mature must be specifically distinct from forms with elongate and coelomic spermathecal atria.

D. gisti var. *anchingiana* Chen, 1933, is not adequately described but differs from the types as follows: limitation of the penis pouches (?) to the body wall, small size and smooth surface of the prostates, and the presence of the spermathecal atria in vii rather than viii. These differences are important enough to distinguish the worms specifically from *D. gisti*. The specimens may not be sexually mature—*vide* absence of granulations on the prostates, the empty ovisacs, and the small size of the spermathecal ampullae, as well as the indistinctness of the clitellum.

DRAWIDA GRAHAMI, n. sp.

Length 55 mm, diameter 4 mm. Spermathecal pores in 7/8 midway between *b* and *c*. Male pores in *bc*, nearer to *b* than to *c*, on small porophores seated on 10/11, intersegmental furrow 10/11 ending blindly against the lateral and median sides of the porophores. Genital markings on vii-xiii, each marking with a firm, rounded gland projecting through the parietes into the coelom.

Vas deferens short. Prostates sessile on the parietes, outline circular; central body tiny, ovoidal, pointed end buried in the parietes. Segment xi reduced to a horseshoe-shaped ovarian chamber. Spermathecal atria finger-shaped, erect in viii.

Type.—U.S.N.M. no. 20093, from Suifu, Szechuan.

Distinguished from *D. japonica* by the absence of the appendix on the ovisacs, the more median location of the spermathecal pores, and the sessile prostates.

DRAWIDA JAPONICA Michaelsen, 1892

This species is characterized by a posterior continuation of the ovisac into a very long and slender rodlike appendix, which may extend as far back as segment xliii. These appendices were overlooked by both Michaelsen and Stephenson.

The central body of the prostate is shortly tubular, finger-shaped. The vas deferens passes ectally into the body wall just median to the prostate. The ovarian chamber is horseshoe-shaped. The male pores are located on segment x on the ventral faces of porophores in *bc*, nearer to *b* than to *c*.

D. japonica f. *siemsseni* Michaelsen, 1910 and 1931, is probably specifically distinct from *D. japonica*. It differs from the latter in size, number of gizzards, external genital markings and characteristics of the male porophores. Unfortunately, the internal organs of the single specimen have been lost so that the species cannot be adequately characterized.

D. japonica Chen, 1933, is probably only in part, if at all, conspecific with *D. japonica*. Chen's forms are characterized by greater size (70 to 200 by 3 to 5½ mm rather than 28 to 65 by 1 to 3 mm), location of the male pores, at least in part, on penes or penislike protuberances, and the absence of the characteristic appendices on the ovisacs. Possibly Chen's material is to be referred to two distinct species—mention is made of "some smaller ones about 30 mm long and 2 mm wide also showing sexually mature".

DRAWIDA LINHAIENSIS Chen, 1933

The types of this species are probably not fully mature—*vide* smooth or finely-granular surface of the prostates, the small size of the spermathecal ampullae, and the lack of clitellar development ("clitellum traceable only in one specimen"). The male porophore may possibly contain a spheroidal gland as in *D. nepalensis*.

Further information is needed on the penis (?) pouch (?) and relation of the prostate thereto, as well as on characteristics of the spermathecal atria and ovarian chamber in fully sexual specimens.

DRAWIDA SINICA Chen, 1933

Apparently a good species—the prostates and the spermathecal atria certainly appear to be quite characteristic. The types are not, however, fully mature—*vide* absence of ova in the ovisacs and ovarian segment and the small size and emptiness of the spermathecal ampullae.

DRAWIDA SYRINGA Chen, 1933

The description is rather abbreviated and the species cannot be adequately characterized in absence of information with regard to the central body of the prostates and the relation of the prostatic duct to the penis pouch(?). Length of ovisacs, in view of rather wide intra-specific variation in this characteristic, may possibly be of little importance.

PHERETIMA Kinberg

In this genus especial attention is necessary, in identifications and specific descriptions, to the characteristics and contents of the invaginations at the ectal ends of the male deferent apparatus and of the spermathecae, to the intestinal caeca, to the testis sacs and their relation to the seminal vesicles and to the glands of the genital markings. The failure to describe adequately some of these characteristics has

been responsible for the erection of unnecessary species and for considerable confusion in the synonymy.

Abnormalities probably occur much more frequently in this genus than in most other genera of earthworms and are often of such a nature as to render a particular specimen scarcely recognizable or indeed actually unrecognizable. Considerable taxonomic caution may therefore be necessary not only in connection with unique specimens but even with whole series or large batches.

PHERETIMA ABDITA, n. sp.

Length 80 to 140 mm, diameter $3\frac{1}{2}$ to 6 mm. Setae: vi/30-42, vii/30-44, xvii/14-16, xviii/13-17, xix/16-19, xx/54-69. First dorsal pore in 12/13. Spermathecal pores small, three pairs, in 5/6-7/8.

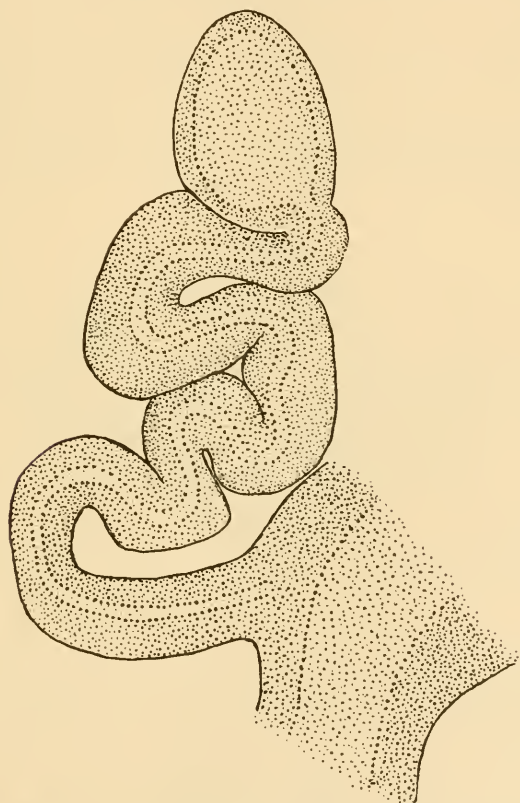

FIG. 1.—*Pheretima abdita*, new species. Spermathecal diverticulum and portion of spermathecal duct, cleared in lactophenol. \times ca. 94.

Male pores at ventral ends of tubular penes located in eversible, deep parietal invaginations with elongately slitlike apertures. Genital markings paired, presetal on xviii and xix.

Septa 8/9-9/10 present and thickly muscular. Intestinal caeca simple. Testis sac of x annular. Testis sac of xi U-shaped or annular. Seminal vesicles of xi included in the posterior testis sac. Spermathecal diverticulum with a short, muscular stalk, a middle portion more or less regularly bent back and forth in a zigzag fashion, and a terminal, ovoidal seminal chamber. Genital marking glands sessile, sometimes slightly protuberant into the coelom.

Type.—U.S.N.M. no. 20094; from Suifu, Szechuan.

Distinguished from *P. floweri* and *P. gemella* as well as from *P. rockefelleri* by the presence and muscularity of septa 8/9-9/10.

PHERETIMA ANTEFIXA, n. sp.

Length 85 to 120 mm, diameter $3\frac{1}{2}$ to 5 mm. Setae: viii/12-14, xiv-xv/+ or -, xvi/7-16, xvii/12-18, xviii/6-10, xix/13-17, xx/36-42. First dorsal pore in 12/13. Spermathecal pores superficial, one pair, in 8/9. Male pores superficial, toward lateral margins of short, transverse ridges. Genital markings unpaired, median, presetal on iii, iv, and v.

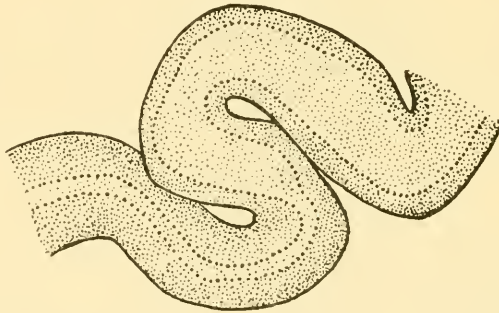

FIG. 2.—*Pheretima antefixa*, new species. Portion of spermathecal diverticulum, cleared in lactophenol.

Intestinal caeca simple. Testis sacs of x and xi unpaired and ventral. Spermathecal diverticulum with a short, muscular stalk and an elongately tubular seminal chamber, the latter nearly straight, twisted or looped. Genital marking glands stalked and coelomic.

Type.—U.S.N.M. no. 20095, from Suifu, Szechuan.

Distinguished from other bithecal species of *Pheretima* with spermathecal pores in 8/9 by the extreme anterior location of the unpaired, median genital markings.

PHERETIMA ASPERGILLUM (E. Perrier), 1872

In the synonymy of this species there must now be placed the following: *Pheretima lauta* Ude, 1905, *Pheretima paraglandularis* Fang, 1929, *Pheretima siemsseni* Michaelsen, 1931 (in part).

PHERETIMA BUCCULENTA, n. sp.

Length 135 mm, diameter 6 mm. Setae: vi/22, vii/22, viii/25, xvii/16, xviii/20, xix/20. First dorsal pore in 12/13. Spermathecal pores minute and superficial, four pairs, in 5/6-8/9. Male pores on tiny, conical tubercles in the dorsalmost portions of deep parietal invaginations with longitudinally slitlike apertures. Genital markings paired, presetal on xviii.

Intestinal caeca simple. Testis sacs of x and xi unpaired and ventral. Genital marking glands sessile but protuberant through the parietes into the coelom.

Type.—U.S.N.M. no. 20096, from "Szechuan".

Distinguished from other octothecal Chinese species of *Pheretima* by the combination of superficial spermathecal pores and deeply invaginate male pores.

PHERETIMA EXILIS, n. sp.

Length 68 to 85 mm, diameter 2 to 2½ mm. Setae: vi/39, xvi/6, xvii/10-15, xviii/8, xix/11-13, xx/50. First dorsal pore in 12/13. Spermathecal pores minute and superficial, two pairs, in 5/6-6/7 or on the posteriormost margins of v and vi. Male pores within slight depressions on glistening, not sharply demarcated areas. Genital markings paired on xvii and xix, probably postsetal.

Intestinal caeca simple. One pair of testis sacs in x. One pair of vertical testis sacs in xi. Seminal vesicles of xi included within the posterior testis sacs. Genital marking glands sessile but slightly protuberant through the parietes into the coelom.

Type.—U.S.N.M. no. 20097, from Suifu, Szechuan.

Distinguished from quadrithecal Chinese species of *Pheretima* with spermathecal pores in 5/6-6/7 by the inclusion of the seminal vesicles of xi within the posterior testis sacs.

PHERETIMA FLEXILIS, n. sp.

Length 40 mm, diameter 2 mm. Setae; vii/16, viii/16, xvii/10, xviii/10, xix/11. First dorsal pore in 13/14. Spermathecal pores minute and superficial, three pairs, in 6/7-8/9. Male pores superficial, at the centers of tiny, transversely oval areas, each area surrounded by

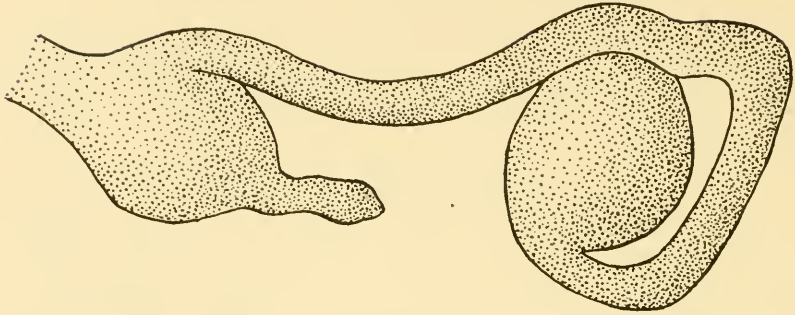

FIG. 3.—*Pheretima exilis*, new species. Spermatheca with iridescent mass in seminal chamber. \times ca. 64.

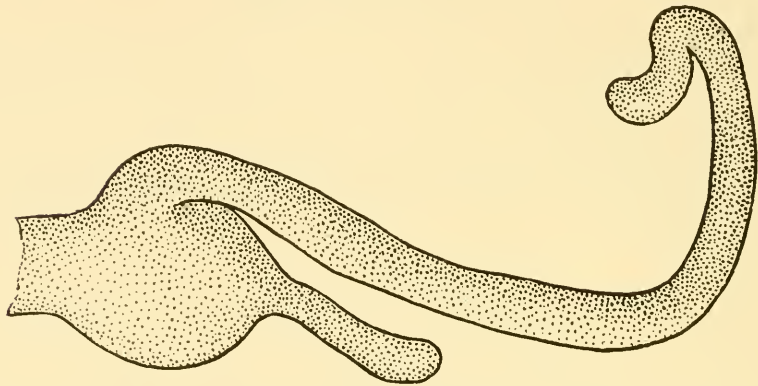

FIG. 4.—*Pheretima exilis*, new species. Spermatheca with no iridescence in diverticulum. \times ca. 64.

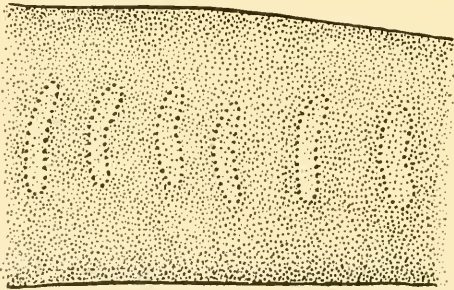

FIG. 5.—*Pheretima fornicata*, new species. An ectal portion of spermathecal diverticulum, cleared in lactophenol.



FIG. 6.—*Pheretima fornicata*, new species. Ental portion of spermathecal diverticulum, cleared in lactophenol. Magnification much less than in fig. 5.

several concentric furrows. Genital markings unpaired and median, presetal on viii, postsetal on xvii and xviii.

Intestinal caeca simple. Testis sac of x horseshoe-shaped. One pair of vertical testis sacs in xi. Seminal vesicles of xi included within the posterior testis sacs. Spermathecal diverticulum with short, muscular stalk and an elongately tubular seminal chamber, the latter variously bent, twisted or looped. Genital marking glands with long, coelomic stalks.

Type.—U.S.N.M. no. 20098, from between Gin Keo Ho and Dawei, Szechuan.

Distinguished from *P. hupciensis* by the absence of septa 8/9-9/10 and from *P. löhri* by characteristics of the testis sacs as well as by the extra pair of spermathecae.

PHERETIMA FORNICATA, n. sp.

Length 78 to 90 mm, diameter 4 to 6 mm. Setae: vi/17-24, vii/19-21, viii/18-23, xvii/13-14, xviii/9-14, xix/12-15, xx/56; a wide dorsal gap in the setal circle of ii. First dorsal pore in 12/13. Spermathecal pores minute and superficial, four pairs, in 5/6-8/9. Male pores superficial, on circular to transversely oval, disk-shaped porophores. No genital markings.

Septum 8/9 present but membranous. Intestinal caeca simple. Testis sacs of x and xi unpaired and horseshoe-shaped. Spermathecal diverticulum with a long, slender stalk and a spheroidal or asymmetrical seminal chamber.

Type.—U.S.N.M. no. 20099, from Tatsienlu, Tibet.

Distinguished from *P. hongkongensis* by the gap in the setal circle of ii, the exclusion of the seminal vesicles of xi from the posterior testis sac, and the absence of genital markings.

PHERETIMA GRAHAMI, n. sp.

Length 235 to 285 mm, diameter 11 to 15 mm. Setae: vii/22-25, viii/22-27, xvii/26, xviii/19, xix/19-25, xx/80-91. First dorsal pore in 12/13-13/14. Spermathecal pores on tiny, conical protuberances into large, club-shaped spermathecal chambers, the latter invaginated posteriorly and deeply into the coelom and bound by connective tissue to the ventral parietes; apertures of spermathecal chambers large, transversely slitlike, three pairs, in 6/7-8/9. Male pores on broadly conical tubercles in large copulatory chambers with apertures approximating to transversely slitlike. External genital markings lacking;

5 to 6 circular to oval, flat-surfaced markings in each copulatory chamber; one large, oval marking on the dorsal (morphologically anterior) wall of each spermathecal chamber.

Intestinal caeca simple. Testis sacs of x and xi unpaired and ventral. Spermathecal diverticulum with a short, muscular stalk and an

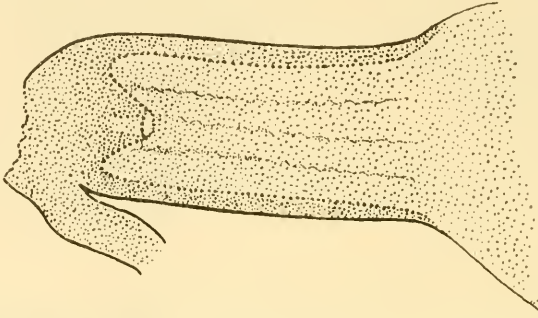

FIG. 7.—*Pheretima grahami*, new species. Portion of spermathecal duct, cleared in lactophenol.

elongately tubular seminal chamber, the latter often looped in a regularly zigzag fashion.

Type.—U.S.N.M. no. 20100, from Da Shiang Lin Pass, Szechuan.

Distinguished from *P. vulgaris* by the unpaired, ventral testis sacs and the large, club-shaped spermathecal chambers with their large, oval genital markings.

PHERETIMA GUILLELMI (Michaelsen), 1895

A good species. Distinguished from *P. houlleti* (E. Perrier), 1872, with which it has been confused, by the limitation of the male pore invaginations to the parietes (in *P. houlleti* the male pores are in copulatory chambers). *P. houlleti* Stephenson, 1925, and *P. ichangensis* Fang, 1933, must be included in the synonymy. *Amyntas houlleti* Michaelsen, 1899, is probably also a synonym. *P. vulgaris agricola* Chen, 1930, is probably also, at least in part, a synonym. *P. guillelmi* Chen, 1933, is a composite of *P. guillelmi* and *P. vulgaris*.

PHERETIMA HONGKONGENSIS Michaelsen, 1910

The unpaired testis sac of x is ventral and median. The unpaired testis sac of xi is U-shaped, the limbs of the U reaching to the dorsal blood vessel. The seminal vesicles of xi are included within the posterior testis sac and are surrounded by a layer of testicular coagulum.

The holotype is either not fully sexual or is not quite normal.

PHERETIMA HUPEIENSIS (Michaelsen), 1895

The testis sacs of x and xi are U-shaped. Chen (1933) appears to regard the testis sacs as annular. Chen's account is not quite clear. He places the seminal vesicles of xii in a membranous sac similar to that which contains the seminal vesicles of xi, though there is no testis sac in xii. Coelomic coagulum may sometimes be compacted around the seminal vesicles so closely as to produce an appearance somewhat similar to that of a testis sac filled with testicular coagulum.

Perichaeta hupeiensis Gee, Boring, and Wu, 1927, is certainly not *P. hupeiensis* and is probably a composite of three distinct species.

PHERETIMA IGNOBILIS, n. sp.

Length 55 mm, diameter 3 mm. Setae: vi/17, vii/16, viii/16, xvii/15, xviii/9, xix/16. First dorsal pore in 11/12. Spermathecal pores in parietal invaginations with transversely slitlike apertures, four pairs, in 5/6-8/9. Male pores on the roof and toward the median side of transversely slitlike depressions. No genital markings.

Intestinal caeca simple. Testis sacs of x and xi paired and ventral.

Type.—U.S.N.M. no. 20101, from near Ningyuenfu, Szechuan.

Distinguished from all octothecal Chinese species of *Pheretima* by the location of the spermathecal pores in parietal (or deeper?) invaginations.

PHERETIMA LIMELLA, n. sp.

Length 60-85 mm, diameter 2½-5 mm. Setae: v/38, vi/51, xiv-xvi/+, xvii/18-29, xviii/14-21, xix/18-26. First dorsal pore in 12/13. Spermathecal pores minute and superficial, one pair, in 5/6. Male

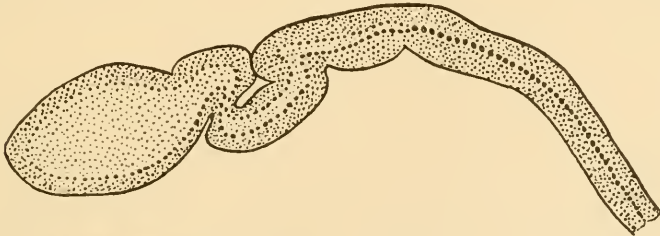

FIG. 8.—*Pheretima limella*, new species. Spermathecal diverticulum, cleared in lactophenol.

pores at centers of small, oval tubercles; a thin fold of tissue at the lateral margin of each male porophore can be drawn mesially over the tubercle in the manner of an eyelid. Genital markings paired and presetal on xvii.

Septa 8/9-9/10 present and thickly muscular. Intestinal caeca simple. Testis sacs of x and xi unpaired. Spermathecal diverticulum with a muscular stalk and an elongate seminal chamber, the ectal portion of the latter looped, the ental portion ovoidal. Genital marking glands sessile.

Type.—U.S.N.M. no. 20102, Suifu, Szechuan.

Distinguished from *P. zoyisiae* Chen, 1933, by the presence and muscularity of septa 8/9-9/10 and by the presence of genital markings.

PHERETIMA MIRABILIS (Bourne), 1887

In the synonymy of this species there must now be placed *P. heterochaeta* (Michaelsen), 1891, and *P. divergens* var. *yunnanensis* Stephenson, 1912.

PHERETIMA MODESTA Michaelsen, 1927

The male pores are in copulatory chambers which, in a completely retracted condition, protrude rather conspicuously into the coelom. A very large portion of the coelomic protuberance is composed of tiny quirks in the prostatic duct on the dorsal face of the chamber and a mass of connective tissue surrounding these quirks. The lumen of the chamber is rather small but is narrowed in the outer layers of the parietes as if by a contraction of an annular, sphincter muscle. In slightly softened specimens the apertures of the chambers gape open, and the lumen of the chamber does not extend internally beyond the level of the coelomic face of the parietes.

In the synonymy of *P. modesta* are to be placed *P. kiangensis* Michaelsen (in part only?) and *P. hesperidum* Chen, 1931 and 1933. The status of Beddard's *P. hesperidum* was discussed in Gates (1932). Stephenson (1933) considered the status of *P. hesperidum* and has also refused to accept Beddard's species.

PHERETIMA OBSCURITOPORA Chen, 1931

Erected on juvenile specimens of uncertain age, in which the adult and hence definitive specific characteristics are unrecognizable. The Szechuan specimens might be rather small juveniles of *P. grahami* or *P. praecipuus*; the Nanking specimens may possibly belong to *P. tschiliensis*.

PHERETIMA OMEIMONTIS Chen, 1931

P. paraglandularis var. *omeimontis* Chen, 1931, is distinguished from *P. paraglandularis* Fang, 1929 (= *P. aspergillum*), by differences so numerous and significant that *omeimontis* must be regarded as specifically distinct.

PHERETIMA PAETA, n. sp.

Length 75-136 mm, diameter 5-6 mm. Setae: viii/22-24, xvii/18-21, xviii/10-16, xix/21-24, xx/65-68. First dorsal pore in 11/12-12/13. Spermathecal pores on circular to oval areas within deep invaginations with transversely slitlike apertures, two pairs, in 7/8-8/9. Male pores on the dorsal wall of large copulatory chambers conspicuously protuberant into the coelom. On the median wall of the copulatory chamber a presetal, transversely oval genital marking, occasionally also a postsetal marking; on the roof of the chamber one or two further markings of variable shape and size. External genital markings paired, on the posteriormost margins of vii and viii, each marking one to three intersetal intervals median to the aperture of the spermathecal invagination.

Intestinal caeca compound, dorsalmost secondary caecum the longest. Testis sacs of x and xi unpaired and ventral. Spermathecal diverticulum with a muscular stalk and an elongately tubular seminal chamber, the latter looped back and forth in a regularly zigzag fashion.

Type.—U.S.N.M. no. 20103, from Song Pan, Szechuan.

Distinguished from *P. omeimontis* by the copulatory chambers, and from *P. schmardae* by the larger size, the invagination of the spermathecal pores, and the presence of genital markings.

PHERETIMA PAPILLIFERA, n. sp.

Length 100 mm, diameter 4 mm. Setae: vi/11 (+ ?), vii/13 (+ ?), xvii/18 (+ ?), xviii/10, xix/10, xx/ca. 41; lacking on ii-iii and dorsally on iv. First dorsal pore in 11/12. Spermathecal pores minute and superficial, three pairs, in 5/6-7/8. Male pores superficial, at centers of circular areas demarcated by slight furrows. Genital markings paired, presetal, on xi-xiv.

Intestinal caeca simple. Testis sacs of x and xi paired. Spermathecal diverticulum with a short muscular stalk and a longer, more irregular seminal chamber. Genital marking glands sessile on the parietes.

Type.—U.S.N.M. no. 20104, from near Zachoo, Szechuan.

Distinguished from sixthelcal Chinese species of *Pheretima* with spermathecal pores in 5/6-7/8 by the absence of setae on ii-iii and dorsally on iv and by the location of the genital markings.

PHERETIMA PECTENIFERA Michaelsen, 1931

The male pore region of *P. pectenifera* is so remarkably similar to that figured for *P. yamadai* Hatai, 1930, that the former may be, in reality, a synonym of the latter. Hatai's species is not adequately

characterized and *P. pectenifera* must, accordingly, be allowed to stand until after reexamination of the Japanese types or amplification of the original description. Further information is needed with regard to size, spermathecal pores, setal numbers, septa 8/9-9/10, intestinal caeca, testis sacs, and the preclitellar genital markings.

Pheretima yamadai Chen, 1933, is almost certainly a composite of two distinct species, *P. pectenifera* and *P. tschiliensis* Michaelsen, 1928. Chen himself distinguishes two forms, A and B; A is probably *tschiliensis*, B probably *pectenifera*.

P. pingi Michaelsen, 1931, may be, in part, synonymous with *P. pectenifera*. At least four of the Hamburg specimens labelled "*P. pingi*" are obviously *P. pectenifera*.

PHERETIMA PINGI Stephenson, 1925

The hearts of x are present but are small, usually empty and bound by connective tissue to the anterior face of 10/11. In these circumstances the hearts of x are easily overlooked. According to Chen (1933) the hearts of x are entirely lacking.

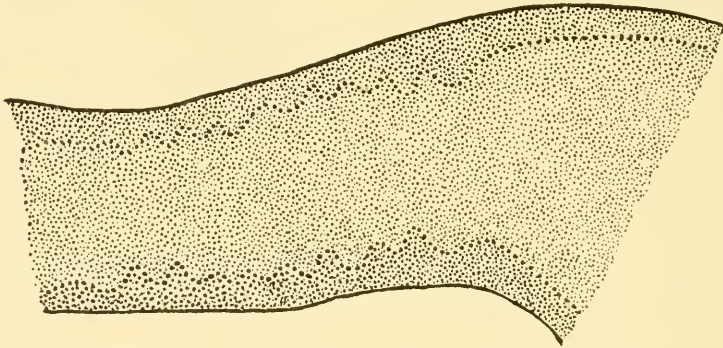

FIG. 9.—*Pheretima pingi*. An ental portion of spermathecal diverticulum, cleared in lactophenol.

(The term "heart" is used to refer to a segmental commissure connecting the ventral blood vessel with the supra-esophageal vessel or the dorsal blood vessel or both, in any of segments ix-xiii.)

PHERETIMA POMELLA, n. sp.

Length 87 mm, diameter 5 mm. Setae: vii/19, xvii/19, xviii/14, xix/19, xx/ca. 50; lacking dorsally on ii. First dorsal pore in 10/11. Spermathecal pores minute and superficial, two pairs, presetal on vii and viii, slightly nearer to the intersegmental furrows than the setal circles. Male pores superficial, on rather indistinctly demarcated areas. Genital markings paired, presetal on xii, xiii and xviii, post-

setal on xviii; markings on xviii in line with male pores, on xii-xiii about in *ab*.

Intestinal caeca simple. Testis sacs of x and xi unpaired and ventral. Spermathecal diverticulum with a short, muscular stalk and an elongately tubular seminal chamber, the latter twisted into a ball-like mass of loops.

Type.—U.S.N.M. no. 20105, from Suifu, Szechuan.

Distinguished from *P. planata* Gates, 1926, by the posterior location of the spermathecal pores, the absence of copulatory chambers, and the locations of the genital markings.

PHERETIMA PRAEPINGUIS, n. sp.

Length 207-(357?) mm, diameter 16 mm. Setae: vii/23, viii/24, xvii/20, xviii/9+, xix/22, xx/93. First dorsal pore in 12/13. Spermathecal pores on tiny tubercles located in parietal invaginations with transversely slitlike apertures, three pairs, in 6/7-8/9. One circular genital marking on the anterior wall of each invagination. Male pores on tubercles in the lateralmost portions of deep parietal invaginations with crescentic apertures, lateral walls of the invaginations thin and nonsetigerous. Just median to each male pore tubercle a single genital marking; on the median wall of the male invagination a transversely oval, presetal genital marking. External genital markings paired, presetal on vii, viii and ix.

Intestinal caeca simple. Testis sacs of x and xi unpaired and ventral. Spermathecal diverticulum with a short, muscular stalk and an elongately tubular seminal chamber, the latter with several slight constrictions.

Type.—U.S.N.M. no. 20106, from Mount Omei, Szechuan.

Distinguished from *P. tschiliensis* by the spermathecal invaginations and the genital markings therein.

PHERETIMA ROBUSTA (E. Perrier), 1872

In the synonymy of this species there must now be placed the following: *P. siemsseni* Michaelsen, 1931 (in part), *P. fokiensis* Michaelsen, 1931, *P. lauta* Ude, 1932. *P. löhri* (Michaelsen), 1899, can be distinguished from *P. robusta* only by the small size. The types of *P. löhri* may be dwarfed forms of *P. robusta*, the dwarfing the result of a heavy infection of parasitic protozoa. *P. lauta* Chen, 1933, is probably in large part, if not entirely, synonymous with *P. robusta*. Chen does, however, differentiate between "coast" and "inland" forms, and possibly some of one or both groups may be referable to

P. aspergillum. Chen's specimens appear to be more or less abnormal—"prostates not well developed . . . or totally absent or very rudimentary".

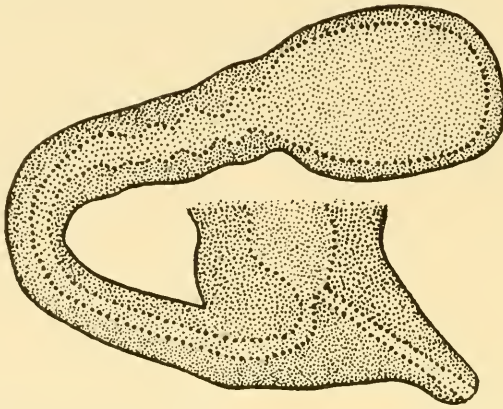

FIG. 10.—*Pheretima robusta*. Portion of a spermatheca, cleared in lactophenol.
 \times ca. 54.

All Szechuan specimens that can be referred to *P. corrugata* Chen, 1931, are abnormal. The two paratypes that have been available for examination are also abnormal. *P. corrugata* is therefore regarded as very dubious, possibly synonymous with *P. robusta*.

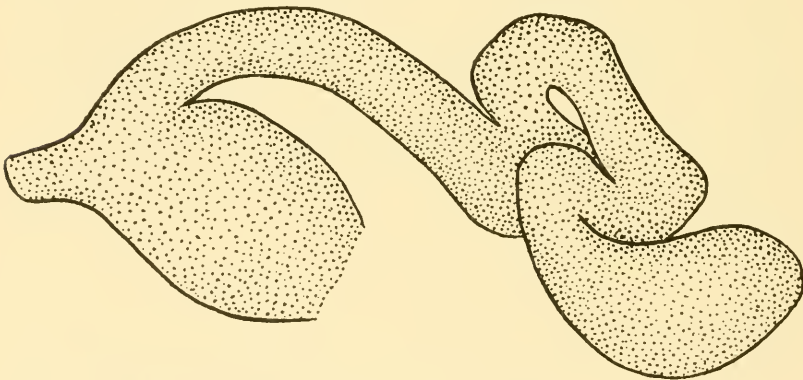

FIG. 11.—*Pheretima schwardae*. Duct and diverticulum of a spermatheca.
 \times ca. 70.

PHERETIMA TSCHILIENSIS MICHAELSEN, 1928

In the synonymy of this form there must now be placed the following: *P. asiatica* Michaelsen, 1902 (in part), *P. tibetana* Michaelsen, 1931, and *P. kiangsuensis* Chen, 1930 and 1931.

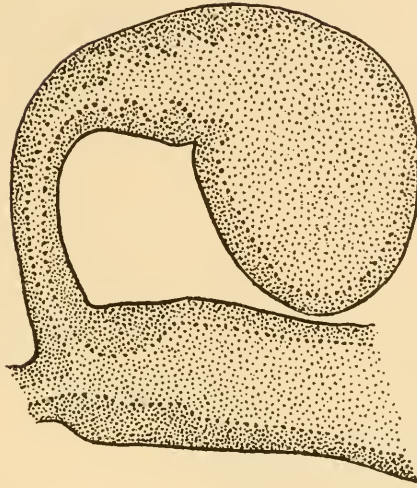

FIG. 12.—*Pheretima szechuanensis*. Spermathecal duct and diverticulum, cleared in lactophenol. \times ca. 52.

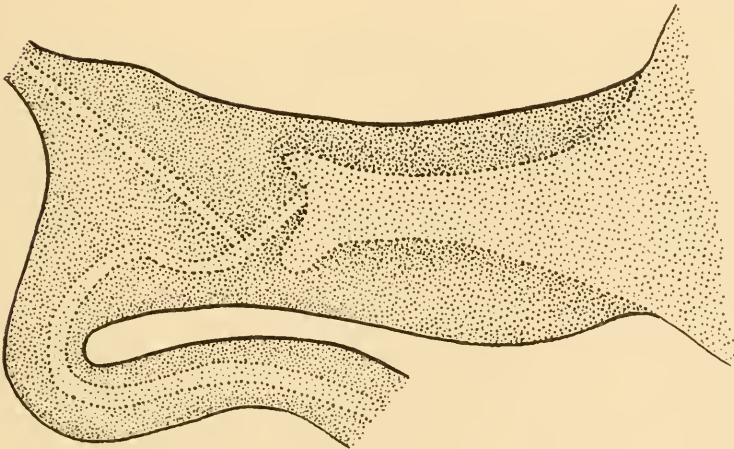

FIG. 13.—*Pheretima tschiliensis*. Spermathecal duct and diverticular stalk, cleared in lactophenol.

Types of *P. asiatica* (Michaelsen), 1900, have not, unfortunately, been available for examination, but inasmuch as Michaelsen's reasons for splitting off *P. tibetana* from *P. asiatica* do not appear to be adequate—especially in view of the variability of the form under consideration—it is quite possible that *P. tschiliensis* may have to be placed in the synonymy of *P. asiatica*. The latter is not, however, sufficiently distinguished from *P. guillelmi* to warrant further change at the present.

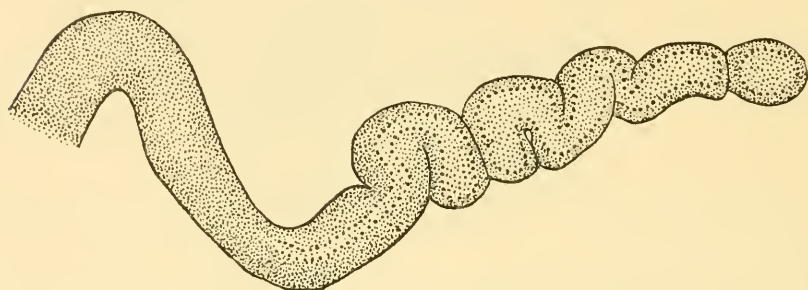

FIG. 14.—*Pheretima tschiliensis*. Spermathecal diverticulum, cleared in lactophenol. \times ca. 45.

PHERETIMA TUBERCULATA, n. sp.

Length 80-110 mm, diameter 3-5 mm. Setae; vi/9-10, vii/9-14, xvii/16-19, xviii/10-13, xix/17-20, xx/40-53. First dorsal pore in 10/11. Spermathecal pores minute and superficial, three pairs, in 5/6-7/8. Male pores superficial, at centers of small, oval areas. Genital markings small tubercles in immediate vicinity of male and spermathecal pores.

Intestinal caeca compound, dorsalmost secondary caecum the longest. Testis sacs of x and xi unpaired and ventral. Spermathecal diverticulum with a muscular stalk and an elongately tubular seminal chamber, the latter often looped in a regularly zigzag fashion. Genital marking glands stalked and coelomic, stalks erect in the coelom.

Type.—U.S.N.M. no. 20107, from Suifu, Szechuan.

Distinguished from sixthelial Chinese species of *Pheretima* with spermathecal pores in 5/6-7/8 by the compound intestinal caeca.

PHERETIMA VULGARIS Chen, 1930

A good species if the account of the typical forms is correctly interpreted, distinguished from *P. guillelmi*, with which Chen has lately (1933), confused it, by the characteristic club-shaped copulatory chambers as well as by the spermathecal invaginations.

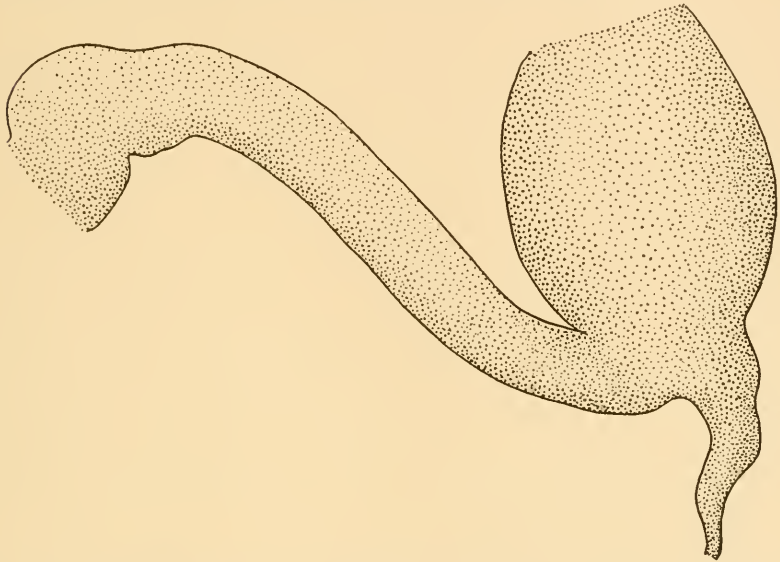

FIG. 15.—*Pheretima vulgaris*. Spermathecal duct and ectal portion of diverticulum. \times ca. 36.

P. pingi Michaelsen, 1931, and *P. kiangensis* Michaelsen, 1931, are probably, at least in part, synonymous with *P. vulgaris*; some of the Hamburg specimens labelled *P. pingi* and *P. kiangensis* are obviously *P. vulgaris*. An acitellate specimen from Ichang in Hupeh, referred by Fang to *P. vulgaris*, is correctly identified, but specimens from Peiping referred to *P. vulgaris* by Fang cannot be properly placed.

LITERATURE CITED

CHEN, Y.

1933. A preliminary survey of the earthworms of the lower Yangtze valley. Contr. Biol. Lab. Sci. Soc. China, vol. 9, no. 6.

GATES, G. E.

1932. The earthworms of Burma. III. The Megascolecinae. Rec. Indian Mus., vol. 34, pt. 4.

STEPHENSON, J.

1933. Oligochaeta from Australia, North Carolina, and other parts of the world. Proc. Zool. Soc. London, 1932.

SMITHSONIAN MISCELLANEOUS COLLECTIONS
VOLUME 93, NUMBER 4

PIONEER WIND TUNNELS

(WITH 4 PLATES)

BY

N. H. RANDERS-PEHRSON

Assistant, Division of Aeronautics, Library of Congress



(PUBLICATION 3294)

CITY OF WASHINGTON
PUBLISHED BY THE SMITHSONIAN INSTITUTION
JANUARY 19, 1935

The Lord Baltimore Press
BALTIMORE, MD., U. S. A.

PIONEER WIND TUNNELS

By N. H. RANDERS-PEHRSON

Assistant, Division of Aeronautics, Library of Congress

(WITH 4 PLATES)

In a paper read before the Royal Society in 1759 John Smeaton presented the following very neat outline of the various methods that may be used for aerodynamic research:¹

In trying experiments on wind mill sails, the wind itself is too uncertain to answer the purpose; we must have recourse to an artificial wind. This may be done two ways; either by causing the air to move against the machine, or the machine to move against the air. To cause the air to move against the machine, in a sufficient volume, with steadiness and the requisite velocity, is not easily put in practice: To carry the machine forward in a right line against the air, would require a larger room than I could conveniently meet with. What I found most practicable, therefore, was to carry the axis, whereon the sails were to be fixed, progressively round in the circumference of a large circle.

Technical difficulties prevented Smeaton from using a wind tunnel and prompted him to adopt the whirling machine, invented in 1746 by Ellicott and Robins. This and other inferior methods of research were in use long after wind tunnels had been constructed and found satisfactory. Thus, Eiffel spent much time dropping plates from the tower bearing his name before adopting the wind-tunnel method; Langley and others used whirling machines, while many used natural wind, which Smeaton had already found to be unreliable.

F. H. WENHAM

The distinction of being the first to introduce the wind tunnel belongs to Francis Herbert Wenham, founder member of the Aeronautical Society of Great Britain, who read at its opening meeting his classical paper on "Aerial Locomotion". In 1871 this Society desired to undertake systematic aerodynamic experiments to obtain "data on which a true science of aëronautics can be founded". A subscription fund was established; an instrument designed by Wenham

¹ Smeaton, John, *Experimental enquiry concerning the natural powers of wind and water*, p. 38, London, 1794.

was approved by the experimental committee and was constructed by John Browning, an optician and member of the Society. It was set up at Messrs. Penn's Marine Engineering Works at Greenwich, where the world's first wind tunnel experiments took place.

The tunnel was a wooden trunk 18 inches square and 10 feet long. Through it was directed the blast from a fan, driven by a steam engine. The wind velocity was measured with a water gauge, various speeds up to 40 miles per hour being used. The wind was not steady, considerable fluctuations making the observations difficult. The direction of the wind was tested with a vane and said to be fairly straight, although there is no mention of a wind straightener of any kind.

The balance was exhibited and explained to the Society by Mr. Wenham. It consisted of a vertical steel spindle, supported on a hardened steel center. Through an eye at the upper end of the spindle passed a horizontal weighing beam, supported by a cross pin axle. The long end of the beam carried the testing planes which could be set at various angles of incidence while they were always kept at right angles across the current. The short end carried a sliding counterweight so as to balance the testing plane. The drag was measured by a spring steelyard connected to a lever from the vertical spindle, close to the base of the machine. The lift was read off by a vertical spring steelyard.

The balance with the testing planes was placed in front of the tunnel at a distance of 2 feet, a wooden shield covering the balance and leaving only the planes exposed to the wind. Lift and drag were measured simultaneously, two persons making the observations. Only plane surfaces were tested, the largest being 18 inches across, the same width as the tunnel. They were placed at various angles from 15° to 60° ; tests on smaller angles were found to be very desirable but could not be achieved with the instrument at hand.

In spite of the crudeness of the tunnel and the shortness of the time allotted for experiments, the results were the most satisfactory of the kind obtained to that time. The experiments were very encouraging to aviation enthusiasts, as they proved that the lift at small angles exceeds the drag to a much greater extent than had previously been suspected. The desirability of a large aspect ratio and the location of the center of pressure near the leading edge were also demonstrated. The test data were published in tabular form in the Report of the Aeronautical Society. These tables were widely used and were also made the basis for actual construction, particularly by Thomas Moy

for his "aerial steamer", the first large power-driven airplane model to rise from the ground in tethered flight.²

Twenty-five years later Wenham expressed the wish that he might have an opportunity to build a large tunnel that would convey a current "at rates varying from a gentle breeze, up to a tornado that could rip the clothes off your back, or blow you away like a feather, but no flying man should mind this effect." In 1900, at the age of 76, he actually rigged up a fan blower for experiments; it ran at 1,700 revolutions per minute and gave a current of 25 miles per hour. Apparently it was driven by hand, as he says:³

I could not get beyond this as it absorbed all my strength to work it, still the current was definite and steady with proper arrangement to measure lift and drift [i. e., drag]. I attached various models in the blast, consisting of different forms of supporting surfaces. 25 miles an hour would be a sufficient speed to begin to fly with.

HORATIO PHILLIPS

Next to use a wind tunnel was another Englishman, Horatio Phillips. He produced his air current by means of a steam jet, hoping in that way to avoid the fluctuations of the wind which had marred Wenham's experiments.

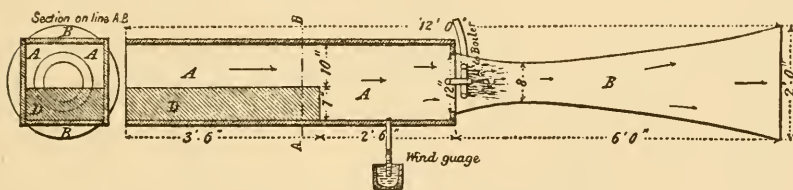

FIG. 1.—Phillips' wind tunnel, 1884.

Phillips' tunnel was 17 inches square and 6 feet long. Attached to one end was "an expanding delivery tube of sheet-iron", which was 6 feet long, 12 inches wide where it entered the box, contracting to 8 inches, and again expanding to 2 feet. In its narrowest part was introduced a ring of iron pipe pierced with holes, through which steam was fed from a large boiler under 70 pounds pressure. This produced by suction an air current in the square part of the tunnel. In order to increase the speed of the current, the square box was partly closed by a

² Aeronautical Society of Great Britain, 6th Ann. Rep., pp. 75-78, 1871; 7th Ann. Rep., pp. 6-12, 1872; 9th Ann. Rep., pp. 6-7, 1874.

³ Unpublished letters from F. H. Wenham to Octave Chanute, now in the Library of Congress.

solid packing of wood, leaving a space 10 by 17 inches in cross-section, where a speed up to 60 feet per second was obtained, as measured by a water gage.

The balance consisted of two uprights, pivoted at the base and connected by a horizontal wire at the top. This passed through eyes on two stiff wires attached to the leading edge of the testing surface. Drag was measured by weights in a scalepan, attached to the model mounting by a string running over a pulley, and lift was measured by a weight suspended under the testing surface at the supposed center of pressure. The balance was pushed into the tunnel where the current was swiftest, so that the scalepan was outside the tunnel, and the suspended weight in a hole in the wood packing.⁴

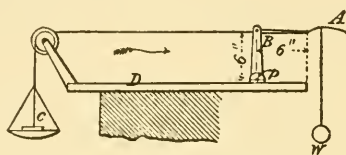

FIG. 2.—Phillips' balance.

While Wenham studied planes only, Phillips turned his attention to curved surfaces. His were the first systematic studies of cambered airfoils, a subject about which practically nothing was known before. Phillips noticed the partial vacuum above the airfoils. He patented a number of profiles, and introduced the downward curving leading edge, now in almost universal use. Several of the airfoils developed by Phillips had a maximum lift-to-drag ratio of about 10, an efficiency adequate for pioneer flying and not known to have been surpassed before the arrival of modern wind tunnels.⁵

The "Venetian blind" airplane built by Phillips, on the basis of data obtained in his wind tunnel, readily lifted itself in tethered flight, and was, with its cambered surfaces, a distinct improvement over its predecessors.

LUDWIG MACH

Dr. Ludwig Mach of Vienna in 1893 was the first to use a wind tunnel to photograph the flow of air. The tunnel had a cross section of 18 by 25 centimeters; one side was of glass and the others black on the inside. The air was sucked through by means of a centrifugal fan

⁴ Engineering, vol. 40, pp. 160-161, illus., London, Aug. 14, 1885.

⁵ British Patent, no. 13,768, 1884; and no. 13,311, 1891.

at the rate of 10 meters per second. A piece of wire mesh over the opening served to straighten the current. By the use of silk threads, cigarette smoke and glowing particles of iron, the flow could be observed. Streams of heated air were also introduced, invisible to the eye, but recording on a photographic plate. A series of good flow photographs was obtained.⁶

JOHAN IRMINGER AND H. C. VOGT

The first wind tunnel measurements of pressure distribution were made by Johan Irminger, and H. C. Vogt, of Copenhagen. Vogt, who was a marine engineer, had made extensive studies on sails and air propellers and had found that the partial vacuum on the leeward side was responsible for the greater part of the thrust. Phillips was first to notice a rarefaction, but did not press his investigation of this factor very far. Vogt, in conjunction with Irminger, director of the Copenhagen Gas Works, undertook a series of wind-tunnel experiments to establish this fact conclusively.

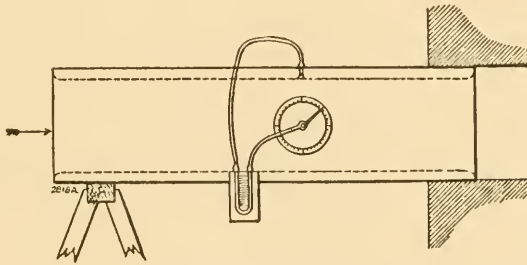

FIG. 3.—Irminger and Vogt's tunnel, 1894.

There was at the gas works a smokestack 100 feet high and 5 feet in diameter, serving a large number of gas furnaces. In order to utilize the draft in this chimney for experimental purposes, an opening was made in its side and a rectangular box inserted, 40 inches long and $4\frac{1}{2}$ by 9 inches inside cross-section. The inside of the box was polished and a shutter was used to control the speed of the air current, which ranged from 24 to 48 feet per second.

To determine the pressure distribution on plane surfaces, two pieces of sheet iron were placed $1/10$ inch apart, joined along the edges to form a shallow closed box. To the interior of this a water gage was

⁶ Zeitschr. Luftschiffahrt und Phys. Atmosphäre, vol. 15, pp. 129-139, pls. I-III, 1896.

connected by means of a pipe. A number of small holes were made in both surfaces, of which one at a time was opened. Two such testing planes were used; both were $1\frac{1}{2}$ inches wide, one $4\frac{1}{2}$ inches long, reaching entirely across the tunnel, the other $2\frac{1}{2}$ inches long. The testing

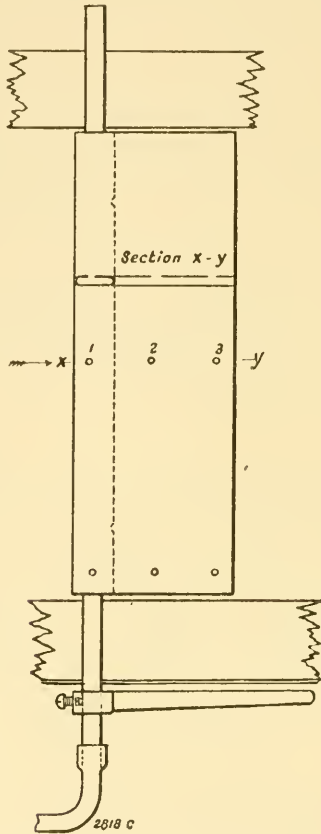

FIG. 4.—Pressure measuring apparatus used by Irminger and Vogt.

planes were placed in the middle of the tunnel and could be set at different angles that were indicated by a pointer on the outside.

Measurements of pressure distribution were also made on bodies of various shapes, as prisms, spheres, etc., and on models of buildings and gas tanks.⁷

⁷ *Ingeniören*, p. 101, Copenhagen, 1894.

Inst. Civil Eng., Minutes of Proc., vol. 118, pp. 468-472, 1894.

Engineering, vol. 60, pp. 787-788, illus., London, Dec. 27, 1895.

CHARLES RENARD

Col. Charles Renard, constructor of the famous airship *La France*, conducted a large number of aeronautical experiments at the *Établissement Militaire de Chalais Meudon*, of which he was the director. Renard continued his experiments during a long period of years and employed a variety of methods and equipment. The details were secret at the time, and the information available is still meager.

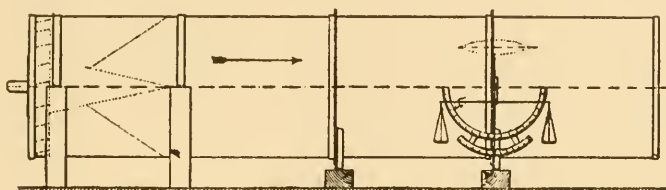

FIG. 5.—Renard's tunnel, 1896.

Some time during the latter half of the nineties a wind tunnel was used. It was cylindrical, 80 centimeters in diameter and 4 meters long. The wind was produced by a blower fan and said to be "violent". Fourteen meters per second is given in a published chart. There is no mention of any means for straightening the wind.

In his tunnel Renard studied the stability and critical speed of airships.⁸ Most of his equipment—balances, testing models, etc.—are preserved in the aeronautical museum at Chalais Meudon.

SIR HIRAM MAXIM

For the construction of his giant airplane, Sir Hiram Maxim realized the necessity for scientific data and utilized a number of testing devices. Among these was a wind tunnel which was in operation in 1896. Maxim's tunnel was a wooden box 12 feet long and 3 by 3 feet inside cross-section, connected with a shorter box 4 feet square. Two air-screws on the same shaft, placed in the wider section and driven by a 100-hp. steam engine, blew the air through the tunnel. To straighten the airstream a number of wooden slats were placed in the tunnel horizontally, vertically, and diagonally. The objects to be tested were

⁸ C. R. Acad. Sci., vol. 138, p. 146, June 6, 1904.

Aerophile, vol. 12, pp. 153-155, July 1904.

IV congres internationale d'aeronautique, Nancy 1909. Proces-verbeaux, rapports et memoires, p. 241.

Aeronautique, vol. 6, p. 84, illus., Paris, April 1924.

placed in front of the tunnel and the balance measured both lift and drag.

Sir Hiram tested airfoils, struts, and airplane parts in his wind tunnel, and also the efficiency of steam condenser pipes.⁹

PAUL LACOUR

Two wind tunnels were used by Paul LaCour, of Askov, Denmark, for windmill research. Both were made of sheet iron, cylindrical, 2.2 meters long; one was 1 meter in diameter and the other $\frac{1}{2}$ meter. The wind was produced by electric blower fans and straightened by radial fins inside the tunnels. A speed of 10 meters per second was used, and this was kept constant by controlling the fan speed, which was read from a tachometer. The testing surfaces and windmill models were placed 1 meter out in front of the tunnel.¹⁰

ETIENNE MAREY

Etienne Marey, of Paris, famous for his chronophotographic studies of animal locomotion, in 1899 turned his attention to obtaining photographs of air in motion. This was achieved by the use of narrow bands of smoke in a small, vertical wind tunnel.

The tunnel was 20 by 30 centimeters in cross-section, with front and sides of plate glass and the back covered with black velvet. The air was drawn down through the tunnel by a small suction fan and straightened by passing through fine silk gauze of very even weave.

Smoke was supplied through a row of fine tubes at the top of the tunnel and descended in straight bands, clearly showing the flow past small models that were inserted. Photographs were taken by means of a magnesium flash, burnt in a ventilated box close to one side of the tunnel.

Among the scientists that were interested in these experiments was Samuel P. Langley. He provided funds from the Smithsonian Institution for their continuance, and the next year Marey built a new and improved tunnel. This was 20 by 50 centimeters in cross-section, and the smoke tubes, 60 in number, could be made to vibrate laterally 10 times a second.

⁹ The Aeronautical Annual, 1896, pp. 50-61, illus., Boston.

Maxim, Hiram, Artificial and natural flight, pp. 50-61, illus., New York and London, 1908.

¹⁰ LaCour, Paul, Forsøgsmøllen, pp. 14-15, Copenhagen, 1900.
Ingeniøren, no. 10, Copenhagen, 1897.

The speed of the air at any point was indicated by the undulations of the smoke bands caused by these vibrations. Judging from some of the photographs where the measuring rod is seen, the speed was about 30 centimeters per second.

A number of very beautiful flow photographs were obtained by Dr. Marey.¹¹

A. F. ZAHM

The first complete wind-tunnel laboratory, equipped for a wide range of aerodynamical experiments and with instruments capable of exact measurements, was devised by Dr. A. F. Zahm and erected on the grounds of the Catholic University of America in the winter of 1901.

This laboratory was made possible by Hugo Mattullath, inventor of a giant flying boat, Dr. Zahm having agreed to become, during his spare time, the consulting engineer of Mattullath's company.

The laboratory building was a one-story frame structure 30 by 80 feet and housed a wooden tunnel 6 feet square in cross-section and 40 feet long, with windows in the ceiling and walls. The wind was drawn through at a speed of 27 miles per hour by a 5-foot suction fan, driven by a 12 hp. electric motor. The intake end was covered with one or two screens of cheese cloth or wire mesh to straighten the wind. The air speed was held constant within a fraction of 1 percent by a boy with a tachometer and a rheostat, controlling the fan speed. For some researches movable liners were introduced in the main tunnel, making the current contract trumpetwise to gain speed, then run straight in a narrower stream, and finally discharge as an open jet in the after part of the main tunnel. The testing model was placed either between the parallel sides, where the wind speed was greatest, or in the center of the current where it entered the experimental chamber.

The wind tunnel was equipped with a variety of instruments invented by Dr. Zahm for showing the character of the air flow and its action on the models.

¹¹ C. R. Acad. Sci., vol. 131, pp. 160-163, July 16, 1900; vol. 132, pp. 1291-1296, June 3, 1901.

Ann. Rep. Smithsonian Inst., 1901, pp. 14, 332, 337-340, pls., 1902.

Journ. phys. theroique et appliquee, 4th ser., vol. 1, pp. 129-135, illus., 1902.

Scientific American, n. s., vol. 86, pp. 75-76, illus., Feb. 1, 1902.

Nogues, P., Recherches expérimentales de Marey sur le mouvement dans l'air. France. Min. de l'air. Publ. sci. et techn., pp. 94-97, illus., 1933.

The air speed was measured with a pitot-static tube, connected with an extremely sensitive manometer.¹² This consisted of two thin metal cups, inverted over coal-oil and supported from opposite ends of a weighing beam. Two tubes, one from underneath each cup, were joined respectively to the inner and outer tubes of the speed nozzle. To test the accuracy of this instrument a "balloon anemometer" was devised. A toy balloon floating downstream intersected on its way two thin pencils of light focussed on the moving plate of a long camera constructed for that purpose. This was an adaptation of the ingenious chronograph previously invented by Dr. Zahm for his researches on the speed of bullets.¹³

The manometer was also used for the study of pressure distribution.

Several aerodynamic balances were developed, among them the wire suspension balance, now in general use, and the bell crank balance, now often called the N. P. L. balance. It was called the "universal pressure balance" in 1902, and consisted of a bell crank with horizontal axle mounted on knife edges above the tunnel, having a graduated horizontal arm with scalepan and sliding weights, and a vertical arm running down through a streamline wind shield to hold the models in the air stream.

The laboratory was built and equipped early in 1901 and a description was communicated to the American Association for the Advancement of Science June 30, 1932, and was privately printed (200 copies) in a small pamphlet which is now a great rarity.¹⁴

Mattullath died in December 1902, and the flying-boat project was abandoned, but the scientific work in the laboratory went on intermittently until 1908. Money grants for special researches were made by the Smithsonian Institution and the Carnegie Institution in 1904 and 1905. Results of the investigations were communicated to scientific journals and societies. The most important of these was Dr. Zahm's

¹² Exhibited before the Washington Philosophical Society, May 24, 1902; described in *Phys. Rev.*, vol. 17, pp. 410-423, December 1903. In this paper, p. 417, the term "wind tunnel" is used for the first time.

¹³ The resistance of the air determined at speeds below one thousand feet a second, with description of two new methods of measuring projectile velocities inside and outside the gun. Thesis, Johns Hopkins Univ., 46 pp., illus., 1898.

¹⁴ New methods of experimentation in aerodynamics; outline of some experiments made by H. Mattullath and A. F. Zahm, at the Catholic University of America. Paper communicated to the meeting of the American Association for the Advancement of Science, at Pittsburgh, June 30, 1902. 12 pp., illus., signed A. F. Zahm, Washington, D. C., 1902.

epoch-making paper on "Atmospheric Friction",¹⁵ read before the Philosophical Society of Washington, February 27, 1904.

This paper disclosed for the first time the fact that skin friction is responsible for the major part of the total drag. The tests were made in the wind tunnel on carefully constructed boards up to 16 feet long suspended on the wire balance.

Tests were also made on various spindle- and fish-shaped bodies, establishing the best form for airship hulls and giving, for the first time, the reason why the now universally accepted torpedo shape is preferable. The resistance of wires, struts, wings, and other airplane parts was also studied.

The tunnel was also used for instruction at the University, several students taking part in the experiments. Occasionally, special tests were made for other investigators; for instance, Octave Chanute sent a stuffed buzzard for lift and drag measurements, and Emile Berliner had a monoplane model tested.

WRIGHT BROTHERS

The Wright Brothers' gliding experiments at Kitty Hawk in 1901, although they seemed successful to other observers, were very disappointing to the Wrights themselves, as the new glider did not at all perform according to their calculations based on the aerodynamic tables of Lilienthal. On returning to Dayton in August, they decided to find out by laboratory methods what was wrong.

Their first testing machine consisted of a bicycle wheel mounted horizontally on a spar projecting from the front of a bicycle. The relative aerodynamic efficiency of various surfaces was found by mounting them on this wheel, balancing one against the other and riding the bicycle at a fairly constant speed.

Next they sent the blast from a fan through a square tube and mounted their surfaces as blades on a vane in the stream, balancing a curved surface against a plane surface.

By the middle of October 1901 a small wind tunnel was completed. It was 16 inches square inside and about 6 feet long, with a glass top. The wind was forced through by a blower fan, and passed through a

¹⁵ Atmospheric friction with special reference to aeronautics, pp. 237-276, diags., 1904. From Bull. Philos. Soc. Washington, vol. 14, 1904.

Also printed in England: Atmospheric friction on even surfaces, with commentary note by the Rt. Hon. Lord Rayleigh, F. R. S. Reprinted from the Philos. Mag., July 1904, pp. 58-67, diags.

honeycomb wind-straightener. The air speed was estimated to be 40 feet per second.

The balance was based on the principle of using the normal pressure on a plane surface to measure the lift of an airfoil. The wing model and the normal plane were mounted on separate horizontal cross-stream bars so linked together that the wind lift on the model

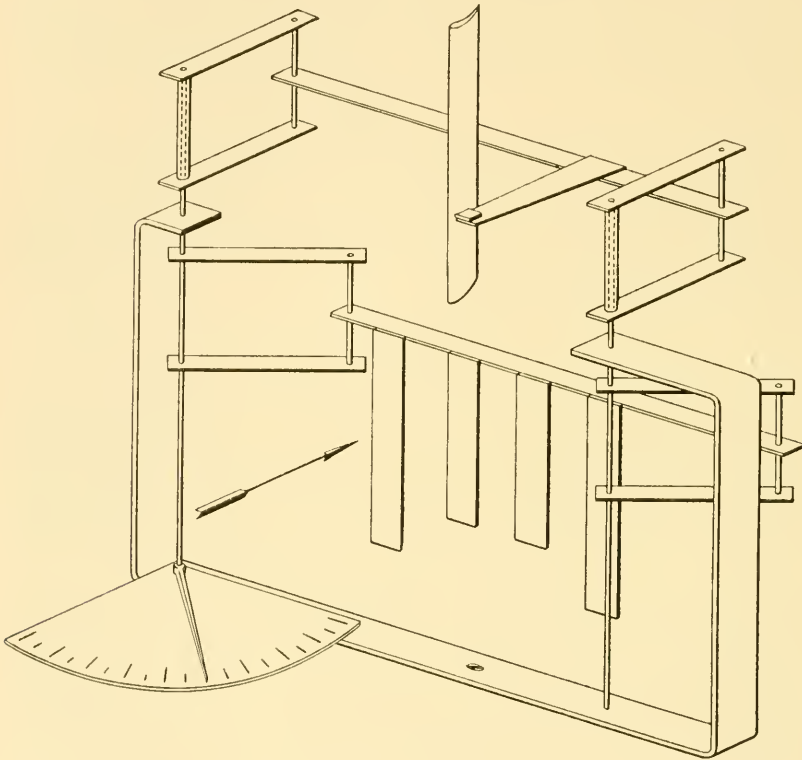

FIG. 6.—Schematic drawing of the Wright Brothers' balance, based on a photograph.

tended to move it across stream. The drag on the normal plane would tend to resist this movement. When the two were exactly balanced, the ratio of lift to the resistance of the normal plane was indicated by a pointer.

A balance of similar construction was later used by Orville Wright in his wind tunnel in Dayton.¹⁰

¹⁰ Warner and Norton, Wind tunnel balances. U. S. Nat. Adv. Comm. Aeronautics, Rep. no. 72, pp. 39-40, 1920.

About 200 wing models made of sheet metal were tested in the wind tunnel. Each model was tested at 14 different angles of incidence, varying from 0° to 45° . Tests were also made to ascertain the effect of varying the aspect ratio, of superposing surfaces, etc. Great care was taken in making the tests; no one but the observer was allowed near the tunnel while it was in operation, and he kept the same position during the extent of the test, in order not to disturb the air current. The results were meticulously noted, and when completed they formed a valuable collection of aerodynamic tables which were later used by the Wrights as the basis for their design. Around Christmas 1902 these experiments came to an end, and the apparatus was taken down.¹⁷

This construction and the Wright Brothers' investigations therewith formed one of the chief factors leading to their success at Kitty Hawk on December 17, 1903.

T. E. STANTON

The first wind tunnel at the National Physical Laboratory in London was set up several years before aeronautics became a subject of research at that institution. This predecessor of the great modern N. P. L. tunnels was built in 1903 by Dr. Thomas E. Stanton, for investigation of wind pressure on surfaces and structures.

Stanton's tunnel was vertical, the upper part a cylinder 2 feet in diameter and $4\frac{1}{2}$ feet long, terminating in a square box 4 by 4 feet, and 1 foot 3 inches deep where the balance was inserted. Underneath this, connected by a shorter length of pipe of the same diameter as the upper part of the tunnel, was the fan chamber. The fan, which produced the wind in the tunnel by suction, was driven by an electric motor and could be regulated to give air speeds from 5 to 30 feet per second.

The balance comprising a horizontal lever carried on knife edges, had a sliding scale, and a scalepan with a dashpot for damping the vibrations. It was inserted in the center part of the tunnel, so that the model projected into the cylindrical section. The long arm of the lever was hollow and could be connected with a sensitive manometer

¹⁷ *Aeronautical Journ.*, vol. 20, pp. 73-74, July-Sept. 1916.

Unpublished letters of Wilbur Wright to Octave Chanute, now in the Library of Congress.

for measurement of pressure. The speed of the current in various parts of the tunnel was measured by a pitot-static tube connected to the manometer.

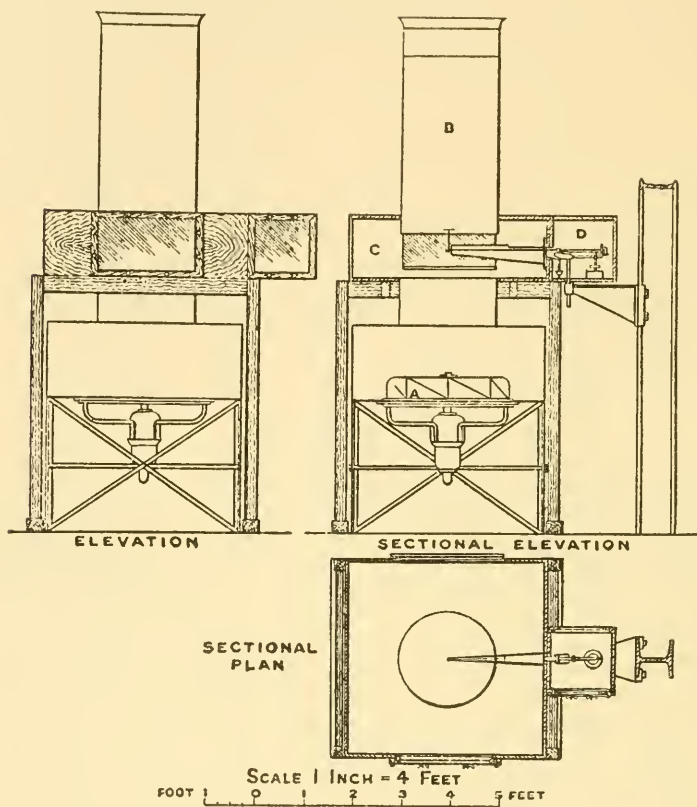

FIG. 7.—Stanton's tunnel, 1903.

Experiments were made in this very carefully constructed little tunnel to determine the resultant pressure and the distribution of pressure on round, square, and rectangular thin plates, normal and inclined to the current, on lattice work, cylinders, and finally on model roofs and bridges. The tunnel was still in use at the time when the 4-foot N. P. L. tunnel was constructed.¹⁸

¹⁸ Inst. Civil Engineers, Minutes of Proc., vol. 156, pp. 78-139, illus., 1904.
Great Britain Adv. Comm. Aeronautics. Rep. 1909-10, p. 14.

G. A. CROCCO

In the fall of 1903 an aerodynamical laboratory was established near Rome by the "Brigata Specialisti" of the 3rd Italian Engineer Corps. The laboratory was built under the direction of Lieutenant, now General, Gaetano Arturo Crocco. It was well equipped with research apparatus, including, as the most prominent part, a wind tunnel of novel construction.

By means of a 2.5-meter centrifugal fan and a 30-hp. electric motor, air was driven into a large cylindrical chamber like a gasometer, 5 meters in diameter and 3.5 meters high, which served to overcome turbulence and fluctuations. From here the wind was conveyed through a tunnel, the end of which was inserted in the laboratory wall, fan and air tank being outside. The cross-section of the mouth of the tunnel was 1 by 1 meter square; also a cross-section of 80 by 80 centimeters was used, and cylindrical mouthpieces of smaller diameter.

The tests were made in the open jet, balance and models being mounted on a support on the floor, on a light carriage, or sometimes on floats swimming in water. The principal balance, constructed by Crocco in 1904, was an improvement on the dynamometric balance of Renard.

For some researches the part of the laboratory where the air entered, was closed off to form a second air-straightening chamber, and the wind continued through a tunnel within the laboratory building. This tunnel was 8 meters long and 0.85 by 1.50 meters in cross-section.¹⁹

The investigations at the laboratory of the Brigata Specialisti were chiefly concerning air propellers and the resistance and stability of airships. The construction of the first Italian military airship in 1907 was based on these tests.

Results of the investigations were also presented in several important papers by Crocco, published in various places, and reprinted in his "Problemi aeronautici, degli albori fino alla guerra." 524 p., illus., 27 pls. (Roma, A. Stock, 1931).

D. RIABOUCHINSKY

Through the efforts of D. Riabouchinsky, a wealthy patron of science and himself a scientist, Russia took its place in the front rank with regard to pioneer aerodynamic research.

¹⁹ Boll. Soc. aeronautica ital., vol. 2, p. 209, illus., Nov.-Dec. 1905.

Marchis. Le Navire aerien. Appendix, pp. 122a-127a, illus. Paris, 1909.

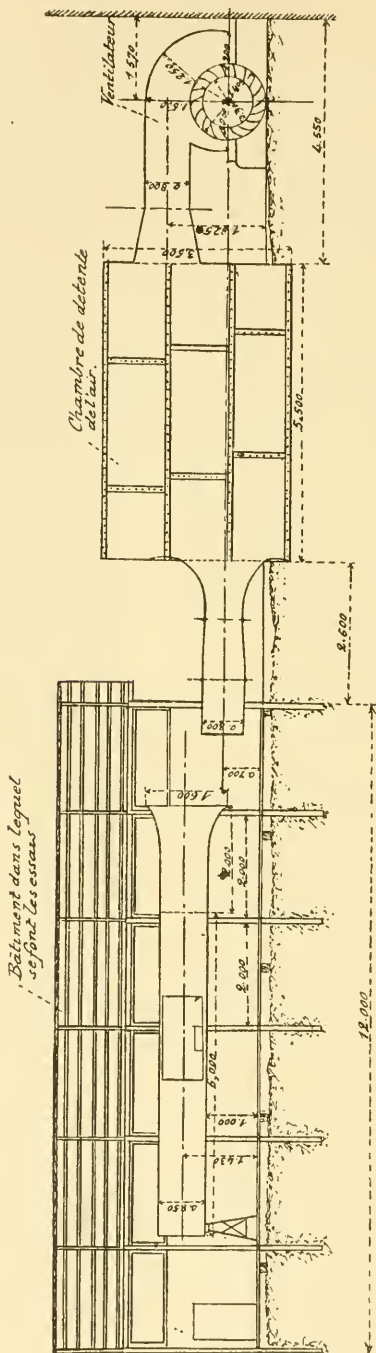

FIG. 8.—Crocco's tunnel, 1903.

At Koutchino, not far from Moscow, Riabouchinsky erected, at his own expense, a complete aerodynamic laboratory with several buildings and an adequate staff. According to a suggestion by Prof. N. E. Joukovsky, the laboratory was equipped with a cylindrical wind tunnel, 14.50 meters long and 1.20 meters in diameter. Wind was produced by a suction fan, driven by an electric motor. Great pains were taken to render the wind uniform. After several experiments that did not give satisfactory results one end of the tunnel was enclosed in a cylindrical hood 2.2 meters in diameter and 3.5 meters long, coaxial with the tunnel itself. This admitted the air in such a way that a sufficiently even current was obtained. The testing section, in the middle of the tunnel, was provided with windows, from which the action of models could be observed.

A great variety of aeronautical and hydrodynamical subjects were studied. Among the researches in the wind tunnel, the experiments with propellers, particularly lifting propellers were important. A bulletin was published by the laboratory in six large issues, the last in 1920.²⁰

LUDWIG PRANDTL

With the construction of the first wind tunnel at Göttingen we are approaching modern times. This was the first return-flow tunnel, built by Dr. Ludwig Prandtl for Motorluftschiffstudiengesellschaft and completed in July 1908.²¹

This tunnel was superseded in 1916-17 by a much larger tunnel with open jet and return flow, which is now called the Göttingen type.

A. RATEAU

With the aid of the Société d'Études de Locomotion Aérienne, A. Rateau built a wind tunnel in Paris in 1909. A 4-foot propeller blew the air into a rectangular chamber, 1.60 meters in cross-section, with an outlet contracting to a nozzle 70 centimeters square. The current was straightened by passing between a number of wooden

²⁰ Institut aérodynamique de Koutchino. 8 pp., 17 pls., St. Petersburg, 1905. Institute aérodynamique de Koutchino, 1904-1914. Moscow, 1914. Bulletin de l'Institut aérodynamique de Koutchino. Fasc. 1-6. Moscow, 1909-1920.

²¹ Motorluftschiffstudiengesellschaft m. b. h. Berlin, Jahrbuch 1907/08-1912/13. Zeitschr. Ver. deutsch. Ingenieure, vol. 53, pp. 1711-1719, Oct. 16, 1909.

slats, and the nozzle made possible speeds of up to 35 meters per second.²²

GUSTAVE EIFFEL

Gustave Eiffel built his first wind tunnel on the Champ de Mars in 1909. It was the open-jet nonreturn tunnel with an airtight testing chamber, known as the Eiffel type. The air current was cylindrical, 1.5 meters in diameter, later enlarged to 2 meters.²³

In 1911 Eiffel moved to Auteuil and built a new and larger laboratory, which he later turned over to the French Government.

NATIONAL PHYSICAL LABORATORY

The N. P. L. built its first large wind tunnel in London in 1910. It was 4 by 4 feet in cross-section and was supported inside another tunnel 8 by 8 feet. The space between the walls of the two tunnels was a return passage for the air, which was drawn through the 4-foot tunnel by a Sirocco fan, driven by a 15 hp. engine.²⁴

This tunnel was not very satisfactory and was replaced in 1912 with a closed-jet nonreturn flow tunnel.

The tunnels of Prandtl, Eiffel, and the N. P. L. have been very briefly described, as their main features are generally known, and full descriptions are readily available.²⁵ They end the pioneer period and begin a new era in wind-tunnel history. Before these three laboratories were established, powered flight had become a proved fact, and airships had met with considerable success. The necessity for reliable laboratory research soon became universally recognized and wind-tunnel laboratories were built and maintained by governments and institutions, as well as by private agencies.

²² *Aérophile*, vol. 27, pp. 266-268, illus., June 15, 1909.

Soc. ingénieurs civils France, *Mém. et C. R. Travaux*, vol. 65, pp. 61-78, illus., July 1912.

²³ Eiffel, Gustave, *Installation d'un laboratoire d'aérodynamique*. Paris, 1910. *La résistance de l'air et l'aviation, expériences effectuées au Laboratoire du Champ de Mars*. Paris, 1910. The resistance of the air and aviation, experiments conducted at the Champ de Mars Laboratory. Translated by Jerome C. Hunsaker. London and Boston, 1913.

²⁴ Great Britain Advisory Committee for Aeronautics, *Rep. 1909-10*, pp. 14-15, 2 folded plates.

Flight, vol. 2, pp. 226-227, March 26, 1910.

²⁵ Zahm, A. F., Report on European aeronautical laboratories, *Smithsonian Misc. Coll.*, vol. 62, no. 3, 23 pp., 11 pls., 5 figs., 1914.

Specifications of Pioneer Wind Tunnels

Date	Name	Cross-section	Air speed	Impeller and engine	Subject of research
1871	Wenham	18 x 18 in. 0.26 x 0.26 m	40 miles per hr. 18 m per sec.	Blower fan Steam engine	Lift and drag of plane surfaces
1884	Phillips	10 x 17 in. 0.25 x 0.43 m	41 miles per hr. 18 m per sec.	Steam jet 70 lbs. pressure	Forces on airfoils
1893	Mach	7 x 9½ in. 0.18 x 0.25 m	22 miles per hr. 10 m per sec.	Suction fan Gas engine	Flow visualization
1894	Irminger and Vøgt	4½ x 9 in. 0.115 x 0.23 m	34 miles per hr. 15 m per sec.	Chimney draft	Pressure distribution
1896	Renard	Diam. 31 in. Diam. 0.80 m	31 miles per hr. 14 m per sec.	Blower fan	Stability and critical speed of airships
1896	Maxim	3 x 3 ft. 0.91 x 0.91 m	49 miles per hr. 22 m per sec.	Blower fan Steam engine 100 hp.	Airplane parts and condensers
1897	LaCour (2 tunnels)	19½ & 39 in. diam. 0.5 & 1 m diam.	22 miles per hr 10 m per sec.	Blower fan Electric motor 2 hp.	Windmills
1899	Marey	8 x 12 in. 0.20 x 0.30 m	¾ miles per hr.	Suction fan	Flow visualization
1900	Marey	8 x 19½ in. 0.20 x 0.50 m	0.30 m per sec.	Electric motor	

Specifications of Pioneer Wind Tunnels

Date	Name	Cross-section	Air speed	Impeller and engine	Subject of research
1901	Zahm	6 x 6 ft. 1.83 x 1.83 m	25 miles per hr. 11 m per sec.	Suction fan Electric motor 12 hp.	Skin friction, air force on wings, struts, hulls, etc.
1901	Wright	16 x 16 in. 0.40 x 0.40 m	27 miles per hr. 12 m per sec.	Blower fan Gasoline engine 2 hp.	Lift and drag. Effect of aspect ratio, etc.
1903	Stanton	24 in. diam. 0.61 m diam.	20 miles per hr. 9 m per sec.	Suction fan Electric motor	Wind pressure on structures
1903	Crocco	39 in. 1 x 1 m	65 miles per hr. 29 m per sec.	Centrifugal blower fan Electric motor	Airship models. Propellers, etc.
1905	Riabouchinsky	4 feet diam. 1.2 m diam.	14½ miles per hr. 6.50 m per sec.	Suction fan Electric motor	Aircrews and general aerodynamic research
1908	Prandtl	6½ x 6½ ft. 2 x 2 m	22 miles per hr. 10 m per sec.	Suction fan Electric motor 34 hp.	Airship models and general aerodynamic research
1909	Rateau	27½ x 27½ in. 0.70 x 0.70 m	78 miles per hr. 35 m per sec.	Blower fan Electric motor 25 hp.	Airfoils. Propellers
1909	Eiffel	5 x 5 ft. 1.5 x 1.5 m	44 miles per hr. 20 m per sec.	Suction fan Electric motor 68 hp.	Airfoils and general aerodynamic research
1909	N. P. L.	4 x 4 ft. 1.2 x 1.2 m	30 miles per hr. 13 m per sec.	Centrifugal suction fan Electric motor 15 hp.	General aerodynamic research

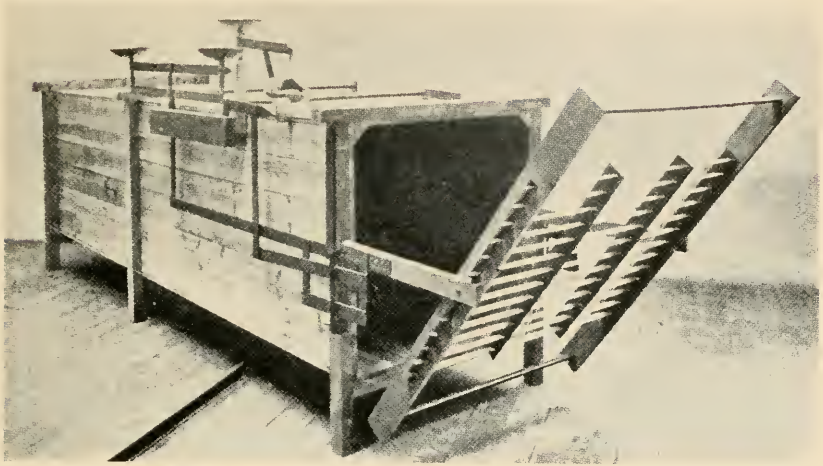

1. MAXIM'S TUNNEL, 1896

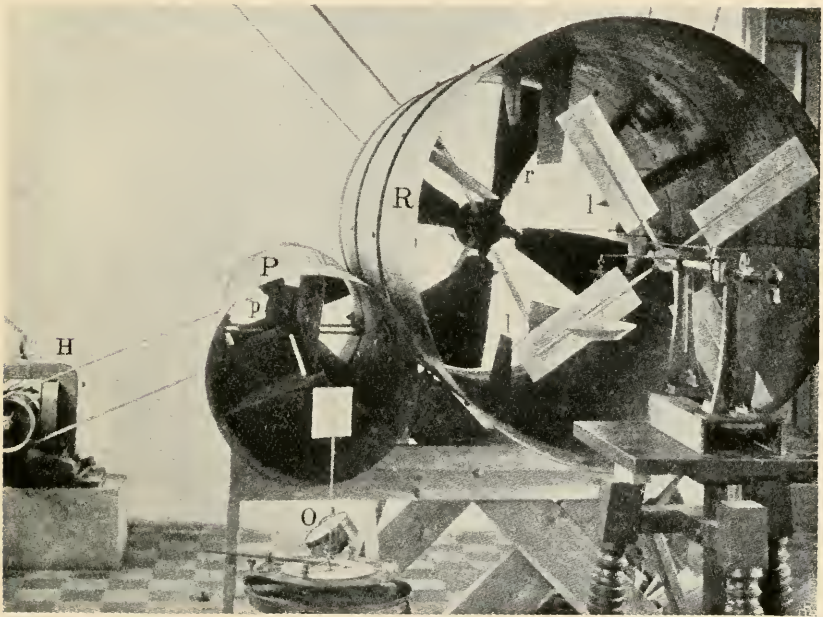

2. LA COUR'S TWO TUNNELS, 1897

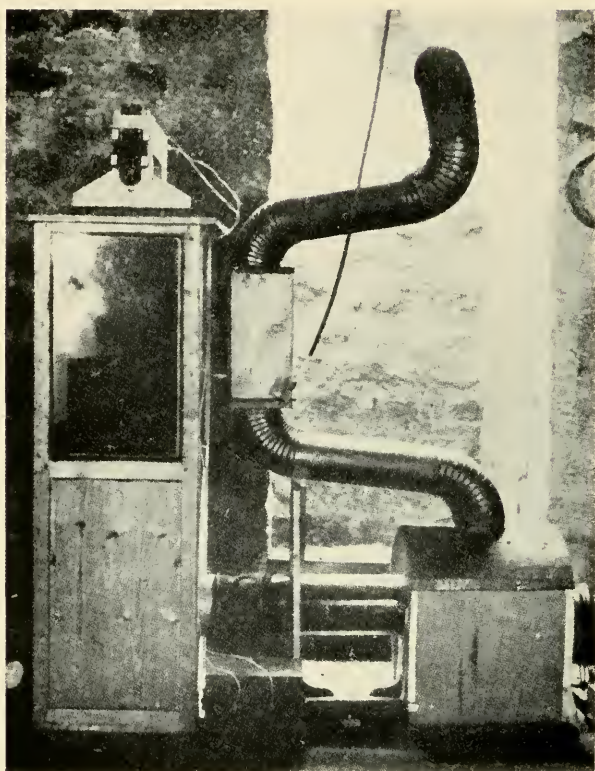

MAREY'S TUNNEL, 1900



1. A. F. ZAHM'S AERODYNAMIC LABORATORY, 1901

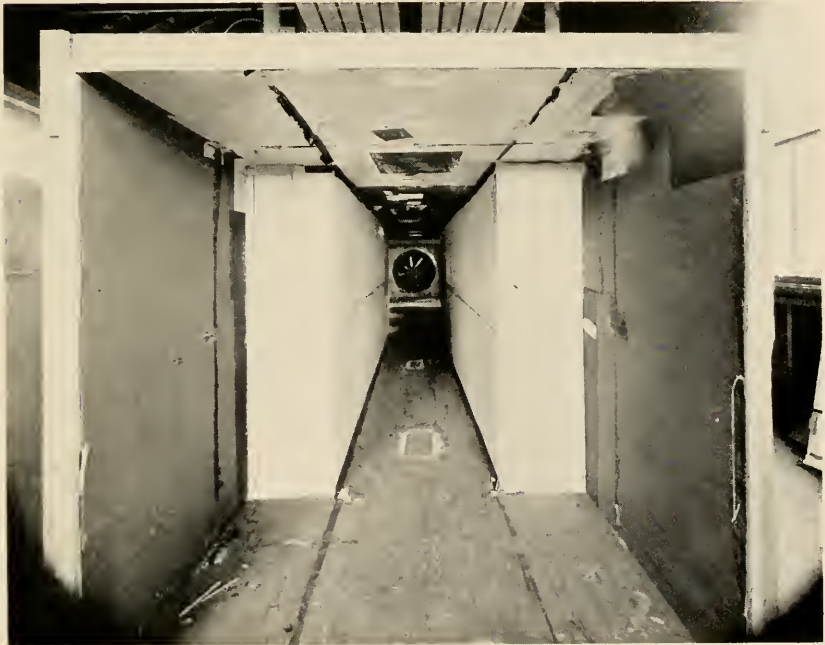

2. ZAHM'S TUNNEL WITH INTAKE CONE REMOVED

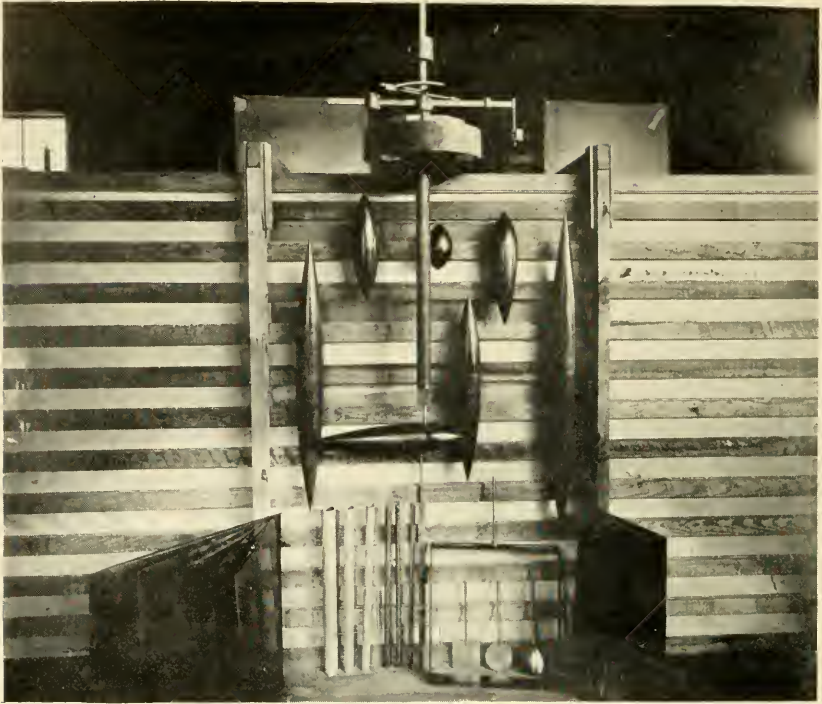

BALANCE AND GROUP OF TEST MODELS USED IN ZAHM'S TUNNEL

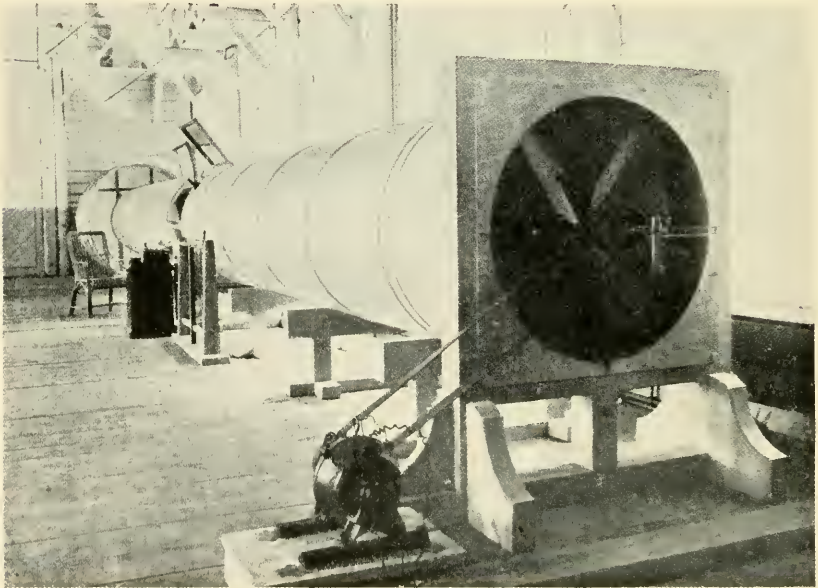

RIABOUCHINSKY'S TUNNEL, 1905

SMITHSONIAN MISCELLANEOUS COLLECTIONS
VOLUME 93, NUMBER 5

NOMENCLATURE OF SOME CAMBRIAN TRILOBITES

BY
CHARLES ELMER RESSER
Curator, Division of Invertebrate Paleontology,
U. S. National Museum



(PUBLICATION 3295)

CITY OF WASHINGTON
PUBLISHED BY THE SMITHSONIAN INSTITUTION
FEBRUARY 14, 1935

The Lord Baltimore Press
BALTIMORE, MD., U. S. A.

NOMENCLATURE OF SOME CAMBRIAN TRILOBITES

By CHARLES ELMER RESSER

*Curator, Division of Invertebrate Paleontology,
U. S. National Museum*

INTRODUCTION

After many years devoted to intensive study of Cambrian stratigraphy and paleontology, the author hopes soon to submit for printing a complete summary of available information on the subject. During the course of this research many interesting facts have been brought to light, and it becomes clear that much of the paleontology is not up to date. To include the necessary nomenclatural changes in the bibliographic portion of the summary would be to bury them; hence it is planned to publish, from time to time, separate papers embodying necessary changes.

Dr. Charles D. Walcott's intention to monograph the Cambrian trilobites as he did the brachiopods was repeatedly stated in his writings and discussed in conversation over a period of many years. He finally came to realize that this would be more than a life-long work, since, while brachiopod species are numbered by hundreds, the trilobites comprise thousands. Unfortunately, just as he was well started on the description of the many new species in hand, matters pertaining to the World War robbed him of his research time. Although he accomplished much in this line, his assemblage of trilobites was so vast that many of the species remained unstudied and undescribed.

With the study of the new material generic relationships formerly obscure become apparent, and a more satisfactory classification emerges. However, monographic studies of many more groups must be made before families or other groupings above generic rank can be attempted. For this reason the genera discussed in this paper are not referred to families.

The data here presented do not lend themselves to precise systematic arrangement, for time is not available to properly monograph the genera or families discussed; wherefore the information is given in a condensed form, and is arranged alphabetically by genera. However, occasionally rather lengthy descriptions are presented, particularly when important generic questions are involved. Usually incom-

plete bibliographies are given, but they include references to all papers that add information. Care has been exercised to conform strictly to the rules of the International Commission on Zoological Nomenclature. For the sake of lowering publication cost illustrations are omitted from this article, even though they would be desirable, particularly since most papers describing Cambrian fossils are now out of print. New genera and species which require illustration to conform to the rules will be placed in a separate series of papers. Few foreign species are given consideration because several reports either in press or about to be printed care for many of them.

ACROCEPHALITES Wallerius, 1895

Acrocephalites Wallerius, Unders zonen med *Agnostus leavigatus* i Vestergötland, Sweden, p. 52, 1895.

Acrocephalites Walcott, Smithsonian Misc. Coll., vol. 64, no. 3, p. 174, 1916.

Much confusion exists respecting this genus, as many different trilobites have been referred to it simply because they possess a median boss. In fact, the genus was not understood until Westergaard¹ published photographs of the type species. From his studies it is evident that the North American forms cannot even belong to the same family, and consequently fall into other genera. Restricting the genus to species congeneric with the genotype, only three very rare forms remain, viz., *Acrocephalites stenometopus* (Angelin) and *A. ? rarus* Westergaard, from Sweden, and *A. vigilans* Walcott and Resser from Novaya Zemlya.

Diagnosis.—Cranidium alone known. Viewed vertically the facial suture converges forward from the posterior margin, but in side view it rises sharply from the basal plane of the head to the eyes and then drops off equally rapidly to the anterior angles. Cranidium keeled.

Glabella large, about two-thirds as long as the head, tapering forward, but truncated anteriorly; two pairs of glabellar furrows turn sharply back; occipital furrow and ring well defined; sharp occipital spine. Brim with a well-defined rim about one-third the width of the preglabellar area; rim thickened and extended forward into a blunt spine medially. Fixed cheeks half as wide as the glabella; palpebral lobes strongly curved, elevated, and entirely beyond the rather straight course of the facial suture. Surface granulose.

Genotype.—*Solenopleura? stenometopa* Angelin.

Range.—The genus is confined to Upper Cambrian strata in the Atlantic Province.

¹ Sveriges Geol. Unders., ser. Ca, no. 18, p. 123, pl. 1, figs. 20, 21, 1922.

Species formerly referred to *Acrocephalites*:

<i>A. americanus</i> = <i>Alokistocare</i>	<i>A. insignis</i> = <i>Acrocephalops</i>
<i>A. aoris</i> = <i>Alokistocare</i>	<i>A. majus</i> = <i>Alokistocare</i>
<i>A. aster</i> = <i>Deiracephalus</i>	<i>A. multisegmentus</i> = <i>Deiracephalus</i>
<i>A. glomeratus</i> = <i>Modocia</i>	<i>A. tutus</i> = <i>Acrocephalops</i>
<i>A. haynesi</i> = <i>Bolaspis</i>	<i>A. vulcanus</i> = <i>Billingsaspis</i>

ACROCEPHALOPS Poulsen, 1927

Acrocephalops Poulsen, Meddels. Grønland, vol. 70, p. 275, 1927.

Numerous species formerly referred to *Acrocephalites* belong to this genus. At present all forms so identified are confined to the Appalachians and Greenland.

Diagnosis.—Cranidium with tapering glabella, furrowed; fixed cheeks wide, sometimes upturned from the well-defined dorsal furrow; eyes moderately small; eye lines heavy; brim wide, with median boss (usually) and a narrow thickened rim of even width. Free cheeks with no peculiar characteristics. Surface granulated or lined.

Thorax and pygidium not known.

Comparisons.—*Acrocephalops* differs from *Alokistocare* primarily and chiefly in the presence of a thickened rim, narrow and of even width nearly to the anterior angles. From *Bolaspis* it is less clearly separated, the distinguishing criteria being the flatter shield, wider fixed cheeks, eyes apparently never stalked.

Genotype.—*A. gibber* Poulsen.

Range.—Possibly confined to the Middle Cambrian of the Appalachians and Greenland.

DESCRIBED SPECIES REFERRED TO ACROCEPHALOPS

***Acrocephalops tutus* (Walcott)**

Acrocephalites tutus Walcott, Smithsonian Misc. Coll., vol. 64, no. 3, p. 181, pl. 24, figs. 6, 6a, 1916.

Middle Cambrian, Conasauga; (loc. 141) near Cave Spring, Georgia.

Cotypes.—U.S.N.M. nos. 61566, 61567.

***Acrocephalops insignis* (Walcott)**

Acrocephalites insignis Walcott (part), Smithsonian Misc. Coll., vol. 64, no. 3, p. 179, pl. 25, fig. 1 (only), 1916. (Not figs. 1a, 1b = *A. nitida*.)

Again, several species were included under one name and must, therefore, be separated. The name *insignis* is retained for the forms with the strongest sculpturing.

Middle Cambrian, Conasauga; (loc. 112) 5 miles southeast of Center, Alabama.

Lectotype and plesiotypes.—U.S.N.M. no. 61568.

***Acrocephalops nitida*, n. sp.**

Acrocephalites insignis Walcott (part), Smithsonian Misc. Coll., vol. 64, no. 3, p. 179, pl. 25, figs. 1a, 1b, 1916. (Not fig. 1 = *A. insignis*.)

Acrocephalites americanus Walcott, idem, pl. 24, fig. 3a. (This poor specimen may represent the species.)

Unfortunately, none of the illustrated specimens is well preserved, and that shown in figure 1a has been damaged since it was photographed. However, this form clearly has weaker eye lines and other sculpturing than *A. insignis*.

Occurrence same as preceding.

Cotypes.—U.S.N.M. nos. 61569, 61570, and possibly 61560.

ALOKISTOCARE Lorenz, 1906

Alokistocare Lorenz, Zeitschr. deutsch. Geol. Gesell., vol. 58, no. 1, p. 62, 1906.

Alokistocare Walcott, Smithsonian Misc. Coll., vol. 64, no. 3, p. 182, 1916.

Amecephalus Walcott, idem, vol. 75, no. 2, p. 53, 1924.

Amecephalus Walcott, idem, vol. 75, no. 3, p. 65, 1925.

If the rules of nomenclature did not require recognition of *Alokistocare* because Lorenz named a described species as its type, the original description would remain meaningless. Furthermore, the choice of *A. subcoronatum* as the genotype is unfortunate because only cranidia of the species are definitely known, and hence uncertainty prevails as to whether the tail was small or large, which in turn prevents final determination of generic limits. This problem is further complicated by the fact that cranidia similar to that of the genotype occur in entire specimens with both small and large pygidia. However, a search among the scores of cranidia of *A. subcoronatum* from Blacksmith Fork, Utah, reveals the presence of two pygidia which can represent the species, as they are small and similar to those of other species here referred to the genus.

Much confusion exists between *Alokistocare* and *Acrocephalites* as well as among species of several other genera, because many strongly bossed trilobites which appear to belong rightly to *Alokistocare* have been assigned to the Atlantic Province genus *Acrocephalites*, and, as discussed above, their removal leaves no North American species in that genus. On the other hand, certain species must also be removed from *Alokistocare* to new genera.

Owing to the confusion of species, *Alokistocare* has not been properly understood, although in 1916 Walcott presented a diagnosis, evi-

dently based on other than the type species, which is correct in most essential points. Furthermore, it now appears that *Amcephalus* was not well founded and is congeneric with *A. subcoronatum*. The relationship between *A. subcoronatum* and *A. piochensis* is apparent in the cranidium, and if the pygidium mentioned above represents *A. subcoronatum*, this part also conforms. In addition several entire individuals belonging to undescribed species prove this relationship. A new generic diagnosis based on the enlarged group is given below.

Diagnosis.—Entire many-segmented trilobite tapering from a wide cephalon to a small pygidium.

Cephalon semicircular, and usually with considerable convexity. Facial suture diverges only slightly in front of the eyes and is intramarginal for perhaps one-third the distance to the center. Behind the eyes it diverges rapidly, forming short, blunt posterolateral limbs. Glabella marked off by well-defined dorsal furrow; tapers slightly and has three or four usually short glabellar furrows; length usually slightly more than half the length of the cranidium. Occipital furrow developed; neck ring thickened. Brim wide; rim usually defined but sometimes by only a faint furrow; preglabellar area equal to or wider than the rim; and in common with many wide-brimmed trilobites usually has a more or less well developed median boss; brim striated vertically, anterior to the eye lines. Fixed cheeks wide, with large, strongly bowed palpebral lobes. Eye ridges usually strong; eyes small, situated about the middle of the glabella. Free cheeks fairly large, concave toward the margin and with flat, sometimes concave genal spines.

Thorax with approximately 20 segments, which are directed rather straight out, bending downward at the fulcrum and ending bluntly.

Pygidium small, not exceeding in width the diameter of the glabella at the occipital furrow. Axis usually highly arched, as are also the pleural portions. Pleura fused; rim usually not demarcated.

Surface striated vertically on the brim; some species are pustulose or granulose, sometimes with both a fine and a coarse set.

Genotype.—*Conocephalites subcoronatus* Hall and Whitfield.

Range.—Chiefly in the Middle Cambrian, but also late Lower Cambrian.

Species formerly referred to *Alokistocare*:

A. labrosum = *Bolaspis*

A. linmarssoni = *Eldoradia*

A. prospectense = *Eldoradia*

A. tida = *Bolaspis*

DESCRIBED SPECIES REFERRED TO ALOKISTOCARE

Alokistocare americanum (Walcott)

Acrocephalites americanus Walcott (part), Smithsonian Misc. Coll., vol. 64, no. 3, p. 177, pl. 24, figs. 2, 2*b*, and possibly fig. 3, 1916. (Not 2*a* = *A. georgense*; 3*a* = *Acrocephalops nitida*?)

Two and perhaps three species are included in the original cotypes, and a brief examination of the nontype specimens from the locality indicates that perhaps twice that number of species occur. Consequently, the species must be carefully discriminated and restricted to the specimens conspecific with the lectotype.

Middle Cambrian, Conasauga; (loc. 89) Livingston, Georgia.

Lectotype.—U.S.N.M. no. 61557; paratype, no. 61559.

Alokistocare georgense, n. sp.

Acrocephalites americanus Walcott (part), Smithsonian Misc. Coll., vol. 64, no. 3, p. 177, pl. 24, fig. 2*a*, possibly also 3*b*, 1916. (See *A. americanum*.)

Compared with *A. americanum*, this species has more granules, particularly on the brim, and the rim is less thickened but upturned more sharply than shown in the illustrations.

Occurrence same as preceding.

Holotype.—U.S.N.M. no. 61558.

Alokistocare althea Walcott

Alokistocare althea Walcott, Smithsonian Misc. Coll., vol. 64, no. 3, p. 184, pl. 25, figs. 3, 3*a*, 4, 5*a*, 1916.

Middle Cambrian, Bright Angel: (loc. 74) Nankoweap Valley, and (loc. 74*e*) near Indian Garden Springs, Grand Canyon, Arizona.

Cotypes.—U.S.N.M. nos. 61571-61574.

Alokistocare subcoronatum (Hall and Whitfield)

Concephalites subcoronatus Hall and Whitfield, U. S. Geol. Surv. Expl. 40th Parallel, vol. 4, p. 237, pl. 2, fig. 1, 1877.

Ptychoparia subcoronata Walcott, U. S. Geol. Surv. Bull. 30, p. 205, pl. 28, fig. 4, 1886; idem, 10th Ann. Rep., p. 652, pl. 96, fig. 6, 1891.

Alokistocare subcoronatum Lorenz, Zeitschr. deutsch. Geol. Gesell., vol. 58, no. 1, p. 62, fig., 1906.

Alokistocare subcoronatum Walcott, Smithsonian Misc. Coll., vol. 64, no. 3, p. 187, pl. 25, fig. 2, 1916.

Middle Cambrian, Ute; Blacksmith Fork Canyon, east of Hyrum, Utah.

Cotypes.—U.S.N.M. no. 15442.

Alokistocare aoris (Walcott)

Acrocephalites aoris Walcott, Smithsonian Misc. Coll., vol. 64, no. 3, p. 178, pl. 26, figs. 3, 3*b*, 1916.

Middle Cambrian, Pleasant Hill; (loc. 107d) 1 mile northwest of Henrietta, Pennsylvania.

Cotypes.—U.S.N.M. nos. 61579, 61580.

Alokistocare pomona

Alokistocare pomona Walcott, Smithsonian Misc. Coll., vol. 64, no. 3, p. 186, pl. 25, fig. 6, 1916.

It is not altogether certain that this species can remain in *Alokistocare* because of the narrow cranidium, but without additional specimens it cannot be determined how much of this is due to distortion of the soft shale matrix.

Middle Cambrian, Park: (loc. 159f) Near Sixteen, Montana.

Holotype.—U.S.N.M. no. 61577.

Alokistocare majus (Walcott)

Acrocephalites ? majus Walcott, Smithsonian Misc. Coll., vol. 64, no. 3, p. 180, pl. 26, fig. 1, 1916.

It appears that the median boss has been compressed laterally into a ridge.

Middle Cambrian, Meagher; (loc. 4g) North of Gallatin River, east of Logan, Montana.

Holotype.—U.S.N.M. no. 61578.

Alokistocare piochense (Walcott)

Ptychoparia piochensis Walcott (part), U. S. Geol. Surv. Bull. 30, p. 201, pl. 26, 2b; pl. 28, figs. 1, 1a, b, e, 1886. (Not pl. 26, 2a, nor pl. 28, 1c, 1d = *A. packi*: pl. 26, fig. 2 = *Glyphaspis nevadensis*.)

Ptychoparia piochensis Pack (part), Journ. Geol., vol. 14, p. 297, pl. 2, fig. 4a (only), 1906: (For other figures see below.)

Liostracus piochensis Lorenz, Zeitschr. deutsch. Geol. Gesell., vol. 58, no. 1, p. 61, fig., 1906.

Amecephalus piochensis Walcott, Smithsonian Misc. Coll., vol. 75, no. 2, p. 53, pl. 9, 1924.

Amecephalus piochensis Walcott, idem, vol. 75, no. 3, p. 65, pl. 15, figs. 8-10, 1925.

As originally set up this species was a mixture of specific and generic forms. As used by Walcott in 1886, plate 26, figure 2a, and plate 28, figures 1c and 1d, represent another species, *A. packi*; plate 26, figure 2, represents *Glyphaspis*, which may be the same as that described by Pack under the name *Ptychoparia kempfi*. Of Pack's figures, only 4a can possibly belong to *Alokistocare*; however, if this figure is correctly drawn, it is not *piochensis*, but an undescribed species. Figure 4 appears to be *A. packi*, 4b belongs to *Glossopleura packi*, and 4c to *Clavaspidella howelli*.

At first glance this species, which was made the genotype of *Amecephalus*, is quite distinct from *Alokistocare*. Closer examination shows conclusively that it is congeneric with *A. subcoronatum* and must therefore be referred to it as the older genus. Because the specimens are considerably flattened, *A. piochensis* appears somewhat different from *A. subcoronatum*, but if several specimens are carefully examined and variations due to preservation noted, generic distinctions are wanting.

Description.—Entire shield tapers from a wide cephalon to a small pygidium; but because of the fewer thoracic segments, this feature is less pronounced than in other, longer, undescribed species.

Cephalon semicircular in outline and apparently of moderate convexity. Cranidium about equally broad as long. Anterior facial suture diverges about 14° , to rather square anterior corners; intramarginal possibly one-half the distance to the center; posterior portion diverges rapidly, forming long, narrow postero-lateral limbs. Glabella well defined by dorsal furrow, which, as usual, is shallower across the front and anterior to the eye lines; tapers considerably and is a little over half as long as the cephalon. Three pairs of glabellar furrows traceable in some specimens. Occipital furrow shallow in the middle portion, separating a ring of even width. Brim wide, strongly striated vertically, anterior to the eye lines; a slight median boss usually discernible. When the free cheeks are retained, a narrow rim is apt to be present. In most individuals the doublure is pressed through so that its inner edge shows on the upper side as a ridge, with the consequence that many photographs seem to show a broad rim; doublure much wider in the center than toward the anterior angles, owing to the intramarginal course of the facial suture on the under surface. Fixed cheeks wide, eyes small, strongly bowed; eye ridges strong and, when undistorted, apparently fairly straight. Free cheeks also wide, with a concave border; sometimes with a narrow rim; genal spines concave and sharply pointed.

Thorax with 19 segments. Pleura straight; fulcrum far out; furrows in a central position extending to the fulcrum.

Pygidium small, with well-defined axis extending its full length. Pleura well fused, with pleural furrows showing only faintly on certain moulds.

Comparisons.—Confusion of this species with described forms is not likely because of its broad brim and widely placed fulcrum.

Middle Cambrian, Chisholm; (loc. 31) 3 miles northwest of Pioche, Nevada.

Lectotype and paratypes.—U.S.N.M. no. 15434b.

Alokistocare packi, n. sp.

Ptychoparia piochensis Walcott, U. S. Geol. Surv. Bull. 30, p. 201, pl. 26, fig. 2a, pl. 28, 1c, 1d, 1886. (See *A. piochensis*.)

In the narrowness of the cranidium this species is like *A. pomona*. Occurrence same as preceding.

Holotype and paratype.—U.S.N.M. no. 90171.

Alokistocare charax (Walcott)

Ptychoparia charax Walcott, Smithsonian Misc. Coll., vol. 67, no. 2, p. 31, pl. 6, fig. 1, 1917.

Ptychoparia pylas Walcott (part), idem. pl. 6, fig. 4b.

This trilobite seems to belong to *Alokistocare* even though the fixed cheeks are somewhat narrow and eyes slightly large, in which respects it recalls *Glyphasis*, but since it fails to go far enough in that direction, reference to that genus does not seem to be warranted. In the published illustrations the eye lines are drawn too heavy.

Middle Cambrian, Gordon; (loc. 4q, 4v) between Gordon and Youngs Creeks, Lewis and Clarke Range, Montana.

Holotype.—U.S.N.M. no. 63736; paratype, no. 63742.

Alokistocare agnesensis (Walcott)

Olenopsis ? agnesensis Walcott, Smithsonian Misc. Coll., vol. 57, no. 8, p. 242, pl. 36, fig. 2, 1912; idem (part), vol. 67, no. 3, p. 75, pl. 13, fig. 5, 1917. (Not 5a-c = *A. stephenensis*.)

Middle Cambrian, Ptarmigan; (loc. 35m) 3 miles southwest of head of Lake Louise, Alberta.

Holotype.—U.S.N.M. no. 58363.

Alokistocare stephenensis, n. sp.

Olenopsis ? agnesensis Walcott (part), Smithsonian Misc. Coll., vol. 67, no. 3, p. 75, pl. 13, figs. 5a-c, 1917. (Not 5, see preceding.)

Middle Cambrian, Ptarmigan; (loc. 58k) north shoulder Mount Stephen, 3 miles east of Field, British Columbia.

Alokistocare cleora (Walcott)

Olenopsis cleora Walcott, Smithsonian Misc. Coll., vol. 67, no. 3, p. 74, pl. 13, fig. 3, 3a, 1917.

Lower Cambrian, Mount Whyte; (loc. 62w) Gog Lake, Wonder Pass, British Columbia.

Holotype.—U.S.N.M. no. 64396.

Alokistocare stator (Walcott)

Agraulos stator Walcott, Smithsonian Misc. Coll., vol. 64, no. 3, p. 173, pl. 36, fig. 6, 1916; idem, vol. 67, no. 2, p. 28, pl. 6, fig. 6, 1917.

This species is not quite typical of the genus because the tips of the thoracic pleura are blunt, but this feature is hardly a generic criterion.

Middle Cambrian, Ptarmigan; (loc. 35c) Mount Bosworth, British Columbia; (loc. 35m) 3 miles southwest of head of Lake Louise, Alberta.

Holotype.—U.S.N.M. no. 61729.

ANORIA Walcott, 1924

Anoria Walcott, Smithsonian Misc. Coll., vol. 75, no. 2, p. 54, 1924; idem, no. 3, p. 67, 1925.

Genotype.—*Dolichometopus tontoensis* Walcott.

Range.—Middle Cambrian.

DESCRIBED SPECIES REFERRED TO ANORIA

Besides the genotype *A. tontoensis*, several other described species are now referred to the genus.

Anoria bantius (Walcott)

Bathyriscus bantius Walcott, Smithsonian Misc. Coll., vol. 64, no. 5, p. 336, pl. 49, figs. 2-2c, 1916.

Raymond suggested that this species might go into *Athabascia*, (= *Clavaspidella*), but it will be observed that, except for the extension of the pleural furrows to the margin of the pygidium, it has no feature in common with *Clavaspidella*.

Middle Cambrian, Rutledge; (loc. 12b) McAnnallys Ridge, 12 miles northeast of Knoxville, and (loc. 11) 1 mile east of Post Oak Spring, Tennessee.

Cotypes.—U.S.N.M. nos. 62661-4.

Anoria bessus (Walcott)

Dolichometopus ? *bessus* Walcott, Smithsonian Misc. Coll., vol. 64, no. 5, p. 362, pl. 51, figs. 3-3c, 1916.

Middle Cambrian, Park; (loc. 62i) near Sixteen, Montana.

Lectotype.—U.S.N.M. no. 62699; paratypes, nos. 62700-62701.

Anoria baton (Walcott)

Dolichometopus baton Walcott, Smithsonian Misc. Coll., vol. 64, no. 5, p. 362, pl. 51, figs. 2-2b, 1916.

Middle Cambrian, Gordon; (loc. 3j) 6 miles northwest of Scapegoat Mountain, Powell County, Montana.

Lectotype.—U.S.N.M. no. 62696; paratypes, nos. 62697-98.

Anoria utahensis, n. sp.

Bathyriscus productus Walcott (part), U. S. Geol. Surv. Bull. 30, p. 217, pl. 30, figs. 1a, 1g, 1h, 1886.

Sorting of the material from this locality identified as *Bathyriscus productus* in 1886 and referred to *B. anax* in 1916, revealed the fact that neither mentioned species was present but that two other forms represented species referable to two other genera.

Besides the illustrated head and pygidia, many other cranidia are in hand as well as pygidia typical of *Anoria*.

Middle Cambrian, Ophir; (loc. 30a) 1 mile below Argenta Cottonwood Canyon, Wasatch Range, Utah.

Holotype and paratypes.—U.S.N.M. no. 15458.

APHELASPIS, n. gen.

A very abundant trilobite characterizing the upper beds of the Cap Mountain formation was described by Shumard as *Conocephalites depressus*. Recently, the genus has been found in beds of corresponding age in Wisconsin and possibly in the western United States.

Diagnosis.—Cranidium rather long and narrow; rather flat. Facial suture diverges anterior to the eyes. Glabella narrow, slightly tapered; glabellar furrows very faint; occipital furrow shallow but distinct. Brim wide; rim well defined, flat, usually somewhat upturned; preglabellar area more than twice width of rim; usually rather convex. Fixed cheeks only about one-third width of glabella; eye lines clearly developed, eyes moderate in size, situated about center of head; palpebral lobes strongly bowed, palpebral furrow distinct. Free cheeks rather large, long, with long genal spines; ocular platform swollen, elongate.

Pygidium short, wide; axis arched high above pleural lobes, extending to rear margin; three axial furrows clearly defined; pleural furrows less well developed.

Genotype.—*Conocephalites depressus* Shumard.

Name.—*Αφελες* = neat; *ασπίς* = shield.

Range.—Upper Cambrian. Above *Crepicephalus* zone and below Ironton.

Aphelaspis depressa (Shumard)

Conocephalites depressus Shumard, Amer. Journ. Sci. 2d ser., vol. 32, p. 219, 1861.

Ptychoparia depressa Miller, North Amer. Geol. Pal., 1889, p. 565, (gen. ref.).

Inasmuch as Shumard's types were not illustrated and were later destroyed by fire, the propriety of recognizing his species may be questioned, but Walcott long ago set aside specimens as the species, and since they agree with Shumard's description, little doubt of their identity remains.

Upper Cambrian, Cap Mountain (Aphelaspis depressa zone); (loc. 67) Potatotop, 7 miles northwest of Burnet, Texas.

Plesiotypes.—U.S.N.M. no. 90172.

ASAPHISCUS Meek, 1873

Asaphiscus Meek, 6th Ann. Rep. U. S. Geol. Surv. Terr., p. 485, 1873.

Asaphiscus Walcott, Smithsonian Misc. Coll., vol. 64, no. 5, p. 381, 1916.

Asaphiscus was made in a footnote, without illustrations of the type species. Subsequently, the type and other species were well illustrated, but as now constituted several distinct genera are included in *Asaphiscus*.

Diagnosis.—Entire trilobite subelliptical. Cephalon semicircular in outline. Glabella wide, subconical, with only faint traces of glabellar furrows; occipital furrow also almost obsolete. Brim wide; rim wide, slightly thickened, flat, suture intramarginal for a short distance. Fixed cheeks narrow; postero-lateral limbs triangular; palpebral lobes moderately bowed. Free cheeks small, simple, without or with short genal spines.

Nine thoracic segments in genotype.

Pygidium nearly as large as cephalon. Pleural furrows weak; when doublure shows, it appears to have a wide rim.

Genotype.—*A. wheeleri* Meek.

Range.—Middle Cambrian.

Species formerly referred to *Asaphiscus*:

A. agatho = Genus undet.

A. capella = *Glyphaspis*

A. anaxis = Genus undet.

A. duris = Genus undet.

A. bradleyi = (new genus—Canadian age)

A. florus = Genus undet.

A. calanus = *Coosia*

A. granulatus = *Weeksina*

A. calenus = *Glyphaspis*

A. minor = *Cedaria*

A. camma = *Glyphaspis*

A. unispinus = *Weeksina*

DESCRIBED SPECIES REFERRED TO ASAPHISCUS

At present *Asaphiscus iddingsi* Walcott (part) from Manchukuo is the only described species besides the genotype, remaining in the genus, but other new species are at hand.

Asaphiscus wheeleri Meek

Asaphiscus wheeleri Meek, 6th Ann. Rep. U. S. Geol. Surv. Terr., p. 485, 1873.

Asaphiscus wheeleri White, Rep. U. S. Geogr. Surv. West 100th Meridian, vol. 4, p. 43, pl. 2, figs. 1a-f, 1877.

Asaphiscus wheeleri Walcott, U. S. Geol. Surv. Bull. 30, p. 220, pl. 31, figs. 3, 3a; pl. 25, fig. 9, 1886.

Asaphiscus wheeleri Walcott, Smithsonian Misc. Coll., vol. 64, no. 5, p. 390, pl. 58, figs. 1-1g, 1916.

Meek did not figure this species when he described it. Later White figured six specimens, stating that they were those used by Meek. White's figure 1f is the tail of an almost entire individual. The specimen shown in figure 1e is lost, and it is possible that several other unmarked specimens were used by Meek. In 1886 Walcott presented two figures, the entire shield being a composite of Meek's original cotypes. The head shown in figure 3a cannot be located. Walcott (1916) figured eight specimens. Figure 1 is an individual found by G. K. Gilbert and is unusually large and complete. Figure 1e is one of Meek's original cotypes, whereas 1a is again a composite. The small head shown in 1d is from locality 10y near Marjum Pass, several miles from Antelope Springs. Unfortunately, this head was not prepared, and hence the figure is of little worth. All published figures show the rim as thickened, which it is not.

Middle Cambrian, Wheeler; (loc. 4) Antelope Spring, House Range, Utah.

Cotypes.—U.S.N.M. no. 8576 (6 specimens); *plesiotypes*, nos. 62754-62760.

BATHYURISCUS Meek, 1873

Bathyriscus Meek, 6th Ann. Rep. U. S. Geol. Surv. Terr., p. 484, 1873.

Bathyriscus Walcott, U. S. Geol. Surv. Bull. 30, p. 215, 1886.

Bathyriscus Walcott, Smithsonian Misc. Coll., vol. 64, no. 5, p. 330, 1916.

Bathyriscus Raymond, Amer. Journ. Sci., 5th ser., vol. 15, p. 310, 1928.

If the genus is restricted to the forms agreeing with the genotype, only a few described species remain, but many new species will be described from the more recent collections. As the genus is herein described, the species fall into two groups: those with two marginal spines at the anterior corners of the pygidium; and the typical group, which lacks them. Inasmuch as all other characters appear to agree, this feature is not regarded as of generic value.

Genotype.—*Bathyriscus* ? *haydeni* Meek

Range.—Middle Cambrian.

Species formerly referred to *Bathyriscus*:

<i>B.anax</i> = <i>Clavaspidella</i> , etc.	<i>B. lodensis</i> = <i>Glossopleura</i>
<i>B. bantius</i> = <i>Anoria</i>	<i>B. ornatus</i> = <i>Klotziella</i>
<i>B. belesis</i> = <i>Glossopleura</i>	<i>B. productus</i> = <i>Glossopleura</i>
<i>B. belus</i> = <i>Clavaspidella</i>	<i>B. parabola</i> = <i>Glossopleura</i>
<i>B. bithus</i> = <i>Clavaspidella</i>	<i>B. pupa</i> = <i>occidentalis</i> = <i>Poliella</i>
<i>B. dawsoni</i> = <i>Kootenia</i>	<i>B. rossensis</i> = <i>Ptarmingia</i>
<i>B. howelli</i> = <i>Clavaspidella</i>	<i>B. senectus</i> = <i>Bonnia</i>

Reed's species from India, *B. ? stolickai* is not *Bathyriscus*, and most, if not all, of the Chinese forms are in the same category. *B. batis* Walcott, which may come from Lower Cambrian strata has a cranium much too wide to remain in the genus, but the material is so poor that a new name is not now suggested.

DESCRIBED SPECIES REFERRED TO BATHYRISCUS

Besides the species discussed below, *B. rotundatus* (Rominger) belongs to the typical group of the genus.

TYPICAL, NONSPINED GROUP

***Bathyriscus haydeni* (Meek)**

Bathyriscus ? haydeni Meek, 6th Ann. Rep. U. S. Geol. Surv. Terr., (1872) p. 482, 1873.

Bathyriscus haydeni Walcott, Smithsonian Misc. Coll., vol. 64, no. 5, p. 341, pl. 46, figs. 2-2b, 1916.

Meek had very fragmentary material and but little has been found since, but the species is apparently correctly understood.

Middle Cambrian, Meagher; north of the Gallatin River, east of Logan, Montana.

Cotypes.—U.S.N.M. no. 7863.

***Bathyriscus powersi* Walcott**

Bathyriscus (Poliella) powersi Walcott, Smithsonian Misc. Coll., vol. 64, no. 5, p. 351, pl. 46, fig. 1, 1916.

Middle Cambrian, Meagher; Pole Creek, Madison Range, Montana.

***Bathyriscus obrutchevi* (Lermontova)**

Proetus sculptus Korovin (not Barrande) 1924. (Reference not available.)

Olenoides obrutchevi Lermontova, Bull. Com. Geol. Leningrad, vol. 44, no. 8, p. 764, pl. 18, figs. 1-10, 1926.

Middle Cambrian; Tcheremkhova, Irkutsk, Siberia.

***Bathyriscus piedmontensis*, n. sp.**

Bathyriscus sp. undet. Walcott, Smithsonian Misc. Coll., vol. 64, no. 5, p. 348, pl. 49, fig. 3, 3a, 1916.

It is possible that the illustrated pygidium does not belong to the species.

Middle Cambrian, Conasauga ; (loc. 16e) 1 mile southwest of Piedmont, Alabama.

Holotype.—U.S.N.M. no 62665 ; paratype (?), no. 62666.

SPINED GROUP OF BATHYURISCUS

It may prove desirable to separate these forms as a distinct genus.

Bathyuriscus adaeus Walcott

Bathyuriscus adaeus Walcott, Smithsonian Misc. Coll., vol. 64, no. 5, p. 334, pl. 47, figs. 3-3c, 1916.

In most respects this species is much like *B. rotundatus*, but the anterior pygidial segment is extended beyond the margin into spines. The published illustrations fail to show correctly the full length or direction of the spines, which turn backward and reach about to the posterior end of the axis. Further, this spine interrupts the rim and does not arise from it.

The specimen from locality 61j identified as this form represents another species.

Middle Cambrian, Stephen ; (loc. 58j) Mount Stephen, near Field, British Columbia.

Cotypes.—U.S.N.M. nos. 62631-4.

Bathyuriscus atossa Walcott

Bathyuriscus atossa Walcott, Smithsonian Misc. Coll., vol. 64, no. 5, p. 336, pl. 48, figs. 2-2b, 1916.

Middle Cambrian, Spence ; (loc. 55c) Liberty Canyon, west of Montpelier, Idaho.

Lectotype.—U.S.N.M. no. 62642 ; paratypes, nos. 62643-4.

Bathyuriscus marjumensis, n. sp.

Bathyuriscus ? sp. undet. Walcott, Smithsonian Misc. Coll., vol. 64, no. 5, p. 348, pl. 65, fig. 5, 1916.

Presumably this form falls within the spined group of *Bathyuriscus*. If it rightly belongs here, it is apparently the youngest species of the genus known.

Middle Cambrian, Marjum ; (loc. 11p) 2½ miles southeast of Marjum Pass, House Range, Utah.

Holotype.—U.S.N.M. no. 62845.

BILLINGSASPIS, n. gen.

Several Lower Cambrian species referred with a query to *Acrocephalites* constitute a distinct generic group. Since the genotype is a species described by Billings, the hybrid name *Billingsaspis* seems appropriate.

Diagnosis.—Cranidium on the whole truncate-conical in shape; facial suture converging slightly, but because the anterior angles are considerably depressed this feature is accentuated in dorsal view. Glabella tapers considerably; in limestone specimens three pairs of reflexed glabellar furrows traceable. Brim consists of a depressed preglabellar area and a raised and thickened rim; some specimens have a small median boss. Eyes small, eye lines present. Fixed cheeks rather wide and rising from the dorsal furrow to the angular palpebral lobes.

Comparisons.—Superficially, *Billingsaspis* resembles *Bolaspis*, except for the depression where the latter has the great boss in the preglabellar area. Further study is necessary to show whether this resemblance indicates genetic relationship.

Genotype.—*Conocephalites vulcanus* Billings.

Range.—Possibly confined to Lower Cambrian.

Billingsaspis vulcanus (Billings)

Conocephalites vulcanus Billings, Rep. Geol. Vermont, vol. 2, p. 952, fig. 357, 1861; repeated Geol. Canada, p. 286, fig. 296, 1863; original republished. Pal. Fossils Canada, vol. 1, p. 14, fig. 17, 1865.

Ptychoparia vulcanus Walcott, U. S. Geol. Surv. Bull. 30, p. 198, pl. 26, fig. 4 (not 4a), 1886 U. S. Geol. Surv. 10th Ann. Rep., p. 653, pl. 96, fig. 4 (not 4a = "*Ptychoparia miser?*"), 1891.

Acrocephalites ? vulcanus Walcott, Smithsonian Misc. Coll., vol. 64, no. 3, p. 182, pl. 26, fig. 2, 1916.

Lower Cambrian, Parker; (loc. 25) Parkers quarry, Georgia, and (loc. 26) Corman farm, east of Highgate Springs, Vermont.

Cotypes.—U.S.N.M. no. 15437.

BLAINIA Walcott, 1916

Asaphiscus (Blainia) Walcott, Smithsonian Misc. Coll., vol. 64, no. 5, p. 393, 1916.

This undoubtedly deserves full generic rank; in fact, it is doubtful whether it is even closely related to *Asaphiscus*.

Genotype.—*Asaphiscus (Blainia) gregarius* Walcott.

Range.—Middle Cambrian.

Species formerly referred to *Blainia*:

B. glabra = *Blountia*

B. paula = Genus undet.

DESCRIBED SPECIES REFERRED TO BLAINIA

Blainia gregaria (Walcott)

Asaphiscus (Blainia) gregarius Walcott (part), Smithsonian Misc. Coll., vol. 64, no. 5, p. 394, pl. 62, figs. 1, 1b-1i (not 1a = *B. centerensis*), 1916.

It is possible that, even with the specimen figured as 1a eliminated because it has 10 instead of 9 segments, more than one species still remains.

Middle Cambrian, Conasauga; (loc. 90) 3 miles southeast of Center, Alabama.

Lectotype and paratypes.—U.S.N.M. nos. 62797 and 62791, 62793-6, 62798-62801.

Blainia centerensis, n. sp.

Asaphiscus (Blainia) gregarius Walcott (part), Smithsonian Misc. Coll., vol. 64, no. 5, p. 394, pl. 62, fig. 1a, 1916.

This form has 10 instead of 9 thoracic segments.

Occurrence same as preceding.

Holotype.—U.S.N.M. no. 62792.

BOLASPIS, n. gen.

A rather large group of Cambrian trilobites, usually referred to *Acrocephalites* and *Alokistocare* because of the highly developed boss in the center of the preglabellar field, has long needed a generic name.

Diagnosis.—Cranidium characterized by a conical glabella, with one or more pairs of rather sharply reflexed furrows; fixed cheeks wide and tumid; eyes small and sometimes stalked; large rounded or triangular elevation in preglabellar field; rim usually flat and erect, particularly in the middle; neck ring heavy, sometimes extended into a spine. Thorax and pygidium unknown.

Comparisons.—When *Acrocephalites* was first described from fragmentary specimens, which fail to give a true concept of the genus, the conical glabella and the boss in the preglabellar area were the sole generic features apparent. However, after the genus came to be understood, it was apparent that the American species have only a few superficial resemblances and are not related to it.

Comparing *Bolaspis* with *Alokistocare*, we find little similarity except in the possession of the median boss. *Bolaspis* has a much more tapering glabella, its preglabellar area is reduced to triangular form by the down-turned anterior angles, and it lacks the vertical striations crossing the brim.

Genotype.—*Alokistocare ? labrosum* Walcott.

Name.—Βολος = lump, and ασπίς = shield.

Range.—Apparently confined to the Middle Cambrian.

DESCRIBED SPECIES REFERRED TO BOLASPIS

Bolaspis labrosa (Walcott)

Alokistocare ? labrosum Walcott (part), Smithsonian Misc. Coll., vol. 64, no. 3, p. 184, pl. 25, fig. 5 only, 1916. (Not 5a = *B. neihartensis*.)

Several hundred cranidia permit the selection of specimens showing all features.

Description.—Glabella conical, with deeply impressed occipital furrow; two and sometimes three pairs of sharply recurved glabellar furrows are distinguishable on certain individuals; neck ring drawn out into a heavy and probably fairly long spine; brim diamond-shaped, separated from the fixed cheeks by rather heavy, deep furrows which pass forward and outward from the glabella; rim somewhat thickened, highly arched in middle and nearly erect; frontal furrow strong; preglabellar area triangular, rising into a high boss in the middle; fixed cheeks tumid, rising considerably higher than the glabella, the abrupt slope into the preglabellar area at times serving as an eye ridge; eyes small, situated about the middle of the cranidium, and usually stalked.

The surface is granulose; the granules are fairly large and scattered, and are most numerous on the glabella.

At present the free cheeks and pygidia are not located.

Middle Cambrian, Meagher; (loc. 5f) 11 miles south of Neihart, Montana.

Lectotype and plesiotype.—U.S.N.M. no. 61575.

Bolaspis neihartensis, n. sp.

Alokistocare ? labrosum Walcott (part), Smithsonian Misc. Coll., vol. 64, no. 3, p. 184, pl. 25, fig. 5a only, 1916.

Among the cotypes of *B. labrosa* is a much shorter and more compact form, to which the name *B. neihartensis* is given.

Comparisons.—Compared with *B. labrosa*, the brim is reduced in width, with the consequent loss of the prominent boss. Furthermore, the dorsal furrows are more shallow and the fixed cheeks less elevated, so that the whole cranidium is rather evenly convex in cross-section. Finally, the surface of the new species appears to be smooth.

Occurrence same as preceding.

Holotype and paratype.—U.S.N.M. no. 61576.

Bolaspis haynesi (Walcott)

Acrocephalites haynesi Walcott (part), Smithsonian Misc. Coll., vol. 64, no. 3, p. 179, pl. 24, fig. 4b (upper figure only), 1916. (Not 4, 4a = *B. errata*.)

Three species were illustrated as *B. haynesi*, which fact vitiates this as an example of a variable form, and it is necessary to restrict the

name to one of them. Furthermore, among the new collections there are at least four additional species.

The upper of the figures on the slab shown in figure 4*b* agrees most closely with the description and becomes the lectotype of *B. haynesi*. This specimen evidently carried a large occipital spine and not simply a thickened neck ring as in the picture.

Middle Cambrian, Meagher; (loc. 20*k*) Pole Creek, Madison Range, Montana.

Lectotype.—Cast U.S.N.M. no. 61503 (one specimen). (Original in Mus. Comp. Zoöl.)

***Bolaspis raymondi*, n. sp.**

Acrocephalites haynesi Walcott (part), Smithsonian Misc. Coll., vol. 64, no. 3, p. 179, pl. 24, fig. 4*b* (lower specimen), 1916.

This species differs from *B. haynesi* in being less granulose; wider across the fixed cheek, particularly at the anterior angles; and in possessing a stronger boss.

Occurrence same as *B. haynesi*.

Holotype.—Cast U.S.N.M. no. 61562. (Original in Mus. Comp. Zoöl.)

***Bolaspis errata*, n. sp.**

Acrocephalites haynesi Walcott (part), Smithsonian Misc. Coll., vol. 64, no. 3, p. 179, pl. 24, figs. 4, 4*a*, 1916.

B. errata has almost completely lost the median boss, so that the consequently narrower preglabellar area gives it an aspect different from more typical forms of the genus.

Occurrence same as *B. haynesi*.

Holotype.—Cast U.S.N.M. no. 61562. (Original in Mus. Comp. Zoöl.)

***Bolaspis ticida* (Walcott)**

Alokistocare ticida Walcott, Smithsonian Misc. Coll., vol. 64, no. 3, p. 187, pl. 26, figs. 6, 6*a*, 1916.

Until better preserved material becomes available, we can tentatively refer this species to *Bolaspis*.

Middle Cambrian, Bloomington; (loc. 55*s*) Blacksmith Fork, 15 miles east of Hyrum, Utah.

Cotypes.—U.S.N.M. nos. 61589, 61590.

CEDARIA Walcott, 1924

***Cedaria minor* (Walcott)**

Asaphiscus minor Walcott, Smithsonian Misc. Coll., vol. 64, no. 5, p. 388, pl. 61, figs. 3-3*b*, 1916.

Upper Cambrian, Weeks; (loc. 30a) Weeks Canyon, House Range, Utah.

Lectotype and Paratypes.—U.S.N.M. nos. 62778-80.

CLAVASPIDELLA Poulsen, 1927

Clavaspidella Poulsen, Meddels. Grønland, vol. 70, p. 277, 1927.

Athabascia Raymond, Amer. Journ. Sci., 5th ser., vol. 15, no. 88, p. 311, 1928.

This genus differs from the others of the group formerly referred to *Bathyriscus* in having a more rapidly expanding glabella anterior to the eyes, and in its large tail in which the pleural furrows extend to the margin, increasing in width toward their extremities.

Genotype.—*C. sinupyga* Poulsen.

Range.—Middle Cambrian.

Poulsen was uncertain as to the age of the Cape Frederick VII formation, but it seems clearly to represent a portion of the Stephen formation and is therefore Middle Cambrian.

DESCRIBED SPECIES REFERRED TO CLAVASPIDELLA

Poulsen described three species:

Clavaspidella sinupyga *Clavaspidella platyrrhina*
Clavaspidella quinquesulcata

Raymond also referred to *Athabascia*:

Athabascia ostheimeri Raymond *Athabascia belus* (Walcott)
Athabascia glacialis Raymond

***Clavaspidella howelli* (Walcott)**

Bathyriscus howelli Walcott, U. S. Geol. Surv. Bull. 30, p. 216, pl. 30, figs. 2, 2a, 1886. Walcott, Smithsonian Misc. Coll., vol. 64, no. 5, p. 343, pl. 47, figs. 1-1b, 1916.

Middle Cambrian, Chisholm: (loc. 31) 3 miles northwest of Pioche, Nevada.

Lectotype and paratypes.—U.S.N.M. no. 15457.

***Clavaspidella bithus* (Walcott)**

Bathyriscus ? bithus Walcott, Smithsonian Misc. Coll., vol. 64, no. 5, p. 340, pl. 47, figs. 4, 4a, 1916.

Unfortunately, only pygidia of this species have yet been located. When a study of the large quantity of material from this locality is undertaken, heads will likely be found.

Middle Cambrian, Spence; (loc. 55c) Liberty Canyon, West of Montpelier, Idaho.

Lectotype.—U.S.N.M. no. 62635; paratype, no. 62636.

Clavaspidella anax (Walcott)

Bathyriscus anax Walcott (part), Smithsonian Misc. Coll., vol. 64, no. 5, p. 335, pl. 48, figs. 1, 1a, 1c, 1d (not 1b), 1916.

A mere glance at the illustrations shows that the forms from Cottonwood Canyon referred to this species belong to *Glossopleura*.

Middle Cambrian, Ophir; (loc. 55e) Wasatch Range, north of Brigham City, Utah.

Lectotype.—U.S.N.M. no. 62637; paratypes, nos. 62638-40.

Clavaspidella sylla (Walcott)

Bathyriscus (Poliella) sylla Walcott, Smithsonian Misc. Coll., vol. 64, no. 5, p. 354, pl. 65, figs. 2, 2a, 1916.

This species approaches the extreme limits of the genus, but until more forms become available it seems inexpedient to make another genus.

Middle Cambrian, Marjum; (loc. 11o) 4 miles southeast of Antelope Springs, House Range, Utah.

Cotypes.—U.S.N.M. nos. 62837-8.

COOSIA Walcott, 1911**Coosia calanus (Walcott)**

Asaphiscus calanus Walcott, Smithsonian Misc. Coll., vol. 64, no. 5, p. 384, pl. 61, figs. 8, 8a, 1916.

Upper Cambrian, Nolichucky; (loc. 47h) Wolf Creek, Bland County, Virginia.

Cotypes.—U.S.N.M. nos. 62789-90.

DEIRACEPHALUS, n. gen.

Several Upper Cambrian forms previously referred to *Acrocephalites* may be descendants of Middle Cambrian forms but are generically distinct.

Diagnosis.—Cranidium quadrate in general outline. Sutures diverging slightly anteriorly. Glabella tapering, rather conical, somewhat over half as long as the cranidium; no glabellar furrows visible on available specimens. Brim wide with a narrow rim of even width; preglabellar area crossed by a vertical median ridge, beginning at the dorsal furrow and widening out to join the brim. Eye lines strong; palpebral lobes small, situated a little behind the middle of the cranidium. Occipital furrow separating the neck ring, which bears a spine. A beautiful compound eye has been preserved on a free cheek. Surface richly ornamented by pustules, or pustules and lines.

Comparisons.—Compared with the somewhat older species of *Alokistocare* and *Acrocephalops*, this genus resembles both in certain features. Features of the rim as well as the median ridge, which replaces the boss, distinguish it from *Acrocephalops*, and the less expanded brim and the well-defined rim separate it from *Alokistocare*.

Genotype.—*Acrocephalites* ? *aster* Walcott.

Name.— $\Delta\epsilon\iota\rho\alpha\varsigma$ = ridged, $\kappa\epsilon\phi\alpha\lambda\omicron\varsigma$ = head.

Range.—Possibly confined to the Upper Cambrian Crepicephalus zone.

DESCRIBED SPECIES REFERRED TO DEIRACEPHALUS

Deiracephalus aster (Walcott)

Acrocephalites ? *aster* Walcott (part), Smithsonian Misc. Coll., vol. 64, no. 3, p. 178, pl. 26, figs. 9b, 9c, 1916. (Not figs. 9, 9a = *L. buttsi*.)

Upper Cambrian, Conasauga; (loc. 22y) opposite car barn, Birmingham, Alabama.

Holotype.—U.S.N.M. no. 61594.

Deiracephalus buttsi, n. sp.

Acrocephalites ? *aster* Walcott (part), Smithsonian Misc. Coll., vol. 64, no. 3, p. 178, pl. 26, fig. 9, 9a, 1916.

This form is similar to *L. aster* but differs in having fewer pustules and a heavier occipital spine.

Upper Cambrian, Nolichucky; (loc. 107c) west base Copper Ridge, 11 miles northwest of Knoxville, Tennessee.

Holotype.—U.S.N.M. no. 61593.

Deiracephalus multisegmentus (Walcott)

Acrocephalites multisegmentus Walcott, Smithsonian Misc. Coll., vol. 64, no. 3, p. 180, pl. 24, figs. 5, 5a, 1916.

Upper Cambrian, Weeks; (loc. 30n or 30o) 2 miles south of Marjum Pass, House Range, Utah.

Cotypes.—U.S.N.M. nos. 61564-5.

DOLICHOMETOPUS Angelin, 1852

Dolichometopus Angelin, Pal. Scandinavica, pt. 1, Crustacea formationis transitionis Lipsiae, p. 72, 1852. Idem, Pal. Scandinavica, 3d ed. Holmiae, p. 72, 1878.

Dolichometopus Walcott, Smithsonian Misc. Coll., vol. 64, no. 5, p. 355, 1916.

Numerous trilobites belonging to many genera have been referred to *Dolichometopus*, *Corynexochus*, and *Bathyriscus* simply because their glabella tended toward a rectangular form and expand forward. Angelin referred the first two genera to his family Corynexochidae.

No doubt the family is valid, but it must be confined to *Dolichometopus* and *Corynexochus*, which occur only in the Atlantic Province; hence all other American and Asiatic forms must go into other genera. Properly restricted, *Dolichometopus* contains the species *D. acadicus* Matthew and *D. suecicus*, the genotype.

The following list shows the generic position of the North American forms not belonging to the Atlantic Province:

<i>D. baton</i> = <i>Anoria</i>	<i>D. lodensis</i> = <i>Glossopleura</i>
<i>D. bessus</i> = <i>Anoria</i>	<i>D. occidentalis</i> = <i>Poliella</i>
<i>D. bion</i> = <i>Glossopleura</i>	<i>D. productus</i> = <i>Glossopleura</i>
<i>D. boccar</i> = <i>Glossopleura</i>	<i>D. tontoensis</i> = <i>Anoria</i>
<i>D. expansus</i> = (Not determined)	<i>D. varro</i> = <i>Housia</i>

The Oriental species ascribed to the genus all belong elsewhere. Their revision is now under way.

DUNDERBERGIA Walcott, 1924

Dunderbergia Walcott, Smithsonian Misc. Coll., vol. 75, no. 2, p. 56, 1924;
idem, no. 3, p. 85, 1925.

Several species from Nevada, other than the genotype, *D. nitida*, appear to belong to the genus. Undescribed species from other regions also appear to belong to *Dunderbergia*.

Genotype.—*Crepicephalus* (*Loganellus*) *nitidus* Hall and Whitfield.

Range.—Upper Cambrian beds representing the Pterocephalia zone.

DESCRIBED SPECIES REFERRED TO DUNDERBERGIA

Dunderbergia maculosa (Hall and Whitfield)

Crepicephalus (*Loganellus*) *maculosus* Hall and Whitfield (part), U. S. Geol. Expl. 40th Parallel, vol. 4, p. 215, pl. 2, figs. 24, 25?, 1877. (Not fig. 26 = *D. halli*.)

Ptychoparia maculosus Walcott, U. S. Geol. Surv. Monogr. 8, p. 269, 1884.

Upper Cambrian, Secret Canyon; (loc. 62a) opposite Jackson Mine, Eureka District, Nevada.

Holotype.—U.S.N.M. no. 90670.

Dunderbergia halli, n. sp.

Crepicephalus (*Loganellus*) *maculosus* Hall and Whitfield (part), U. S. Geol. Expl., 40th Parallel, vol. 4, p. 215, pl. 2, fig. 26, 1877. (See *D. maculosa*.)

This figured pygidium is not from the same locality as the head of *D. maculosa*, and further, since the cranidia associated with this tail are also distinct, the logical procedure is to combine the two as a new species.

Upper Cambrian, Secret Canyon; (loc. 60) near Richmond Mine, Eureka District, Nevada.

Holotype and paratypes.—U.S.N.M. no. 24617.

Dunderbergia simulator (Hall and Whitfield)

Crepicephalus (Loganellus) simulator Hall and Whitfield, U. S. Geol. Expl. 40th Parallel, vol. 4, p. 218, pl. 2, figs. 16-18, 1877.

Inouyia simulator Walcott, Smithsonian Misc. Coll., vol. 64, 1916.

Upper Cambrian, Secret Canyon; Eureka District, Nevada.

Lectotype.—U.S.N.M. no. 24575; paratypes, no. 24573.

Dunderbergia granulosa (Hall and Whitfield)

Crepicephalus (Loganellus) granulosa Hall and Whitfield, U. S. Geol. Expl. 40th Parallel, vol. 4, p. 214; pl. 2, figs. 2, 3, 1877.

Ptychoparia granulosa Walcott, U. S. Geol. Surv. Monogr. 8, p. 57, 1884.

Inouyia granulosa Walcott, Smithsonian Misc. Coll., vol. 64, no. 3, p. 204, 1916.

Upper Cambrian, Secret Canyon; (loc. 61) near Hamburg Mine and other localities, Eureka District, Nevada.

Holotype.—U.S.N.M. no. 24573.

Dunderbergia pustulosa (Hall and Whitfield)

Ptychaspis pustulosa Hall and Whitfield, U. S. Geol. Expl. 40th Parallel, vol. 4, p. 223, pl. 2, fig. 27, 1877.

Upper Cambrian, Secret Canyon; Pogonip Mountain, White Pine District, Nevada.

Holotype.—U.S.N.M. no. 24579.

Dunderbergia suada (Walcott)

Ptychoparia suada Walcott, Proc. U. S. Nat. Mus., vol. 13, p. 274, pl. 21, fig. 9, 1890.

Upper Cambrian, Wilberns; (loc. 70) Baldy Mountain, near Morgans Creek, 8 miles northwest of Burnet, Texas.

Holotype.—U.S.N.M. no. 23860.

EHMANIA, n. gen.

Many Middle Cambrian species characterized by a peculiar pygidium have been referred to various genera during the past 55 years. When they are gathered together and their features noted, a definite, clear-cut genus emerges. To this is assigned the name of Philip Ehman, of Logan, Montana, who has been of material assistance in restudying the classic region along the north side of the Gallatin Valley.

Diagnosis.—Cranidium of a very common type. Glabella tapered, rounded in form, distinctly demarcated by dorsal furrow; glabellar

furrows usually very faint. Brim variable in width, with a convex preglabellar area and a flat, upturned rim. Eyes moderate in size, not much bowed, situated about the middle of the cranium. Fixed cheeks about half as wide as the glabella. Free cheeks show suture intramarginal for some distance and have a stout, short genal spine.

Thorax has 12 to 14 segments in the specimens observed.

Pygidium wide; axis well defined except at rear; up to six or more axial rings are marked out. Pleural lobes very distinctive because both the pleural furrows and grooves are distinctly impressed to the very margin.

Genotype.—*Ehmania weedi*, n. sp.

Range.—Middle Cambrian.

DESCRIBED SPECIES REFERRED TO EHMANIA

Ehmania gallatinensis (Meek)

Conocoryphe (*Ptychoparia*) *gallatinensis* Meek, 6th Ann. Rep. U. S. Geol. Surv. Terr., p. 485, 1873.

Unfortunately this species is not illustrated, and it is necessary to restrict it to one of the three or more species present in the type lot.

Middle Cambrian, Meagher; north of Gallatin River, near Logan, Montana.

Holotype.—U.S.N.M. no. 7862.

Ehmania walcotti, n. sp.

Ptychoparia antiquata Walcott (part) (not Salter), U. S. Geol. Surv. Monogr. 32, pt. 2, p. 456, pl. 65, fig. 7a, 1899. (Not fig. 7 = *E. weedi*.)

This species was described as a variety. Many fine cranidia and pygidia occur among the specimens not illustrated.

Middle Cambrian, Meagher; (loc. 151d) south of Gallatin River, Crowfoot Ridge, Yellowstone National Park, Wyoming.

Cotypes.—U.S.N.M. no. 90667.

Ehmania weedi, n. sp.

Genotype

Ptychoparia antiquata Walcott (part) (not Salter), U. S. Geol. Surv. Monogr. 32, pt. 2, p. 456, pl. 65, fig. 7 (not 7a), 1899.

This species has more strongly developed glabellar furrows than the other described species.

Occurrence same as preceding.

Holotype.—U.S.N.M. no. 35234.

Ehmania oweni (Walcott)

Ptychoparia oweni Walcott (not Meek and Hayden), U. S. Geol. Surv. Monogr. 8, p. 55, pl. 10, figs. 3, 3a, 1884. (Probably also fig. 18, which is placed with *Eteraspis laeviceps*; and fig. 22.)

Middle Cambrian, Eldorado; east side Secret Canyon, Eureka district, Nevada.

Cotypes.—U.S.N.M. no. 24610.

Ehmania smithi (Walcott)

Anomocarella smithi Walcott, Smithsonian Misc. Coll., vol. 57, no. 4, p. 92, pl. 17, figs. 3-3a, 1911. Research in China, vol. 3, Carnegie Inst. Publ. 54, p. 203, pl. 19, figs. 16-16b, 1913.

Middle Cambrian, Conasauga; (loc. 90x) 3 miles east of Center, Alabama.

Cotypes.—U.S.N.M. nos. 58296, 58298.

ELDORADIA, n. gen.

Still another group formerly referred to *Alokistocare* deserves a separate generic name, and since it seems to reach its best development in the Eldorado limestone of the Eureka District, Nevada, may appropriately be named for the formation.

Diagnosis.—Cranidium generally rectangular in outline, with a tapering glabella about half as long as the cranidium; usually well defined by shallow dorsal furrows; glabellar furrows faint or absent. Brim wide, usually with a large median boss; rim not sharply separated owing to the poor development of the anterior furrow. Fixed cheeks usually wide, with small, sometimes stalked eyes about opposite the anterior end of the glabella.

Comparisons.—Compared with *Bolaspis* and *Acrocephalops*, this genus lies between the two but nearer to the former. From this it differs in greater width of fixed cheek, less clearly defined rim and shallower furrows.

Genotype.—*Ptychoparia* ? *linnarssoni* Walcott.

Range.—Presumably confined to the Middle Cambrian.

DESCRIBED SPECIES REFERRED TO ELDORADIA

Eldoradia linnarssoni (Walcott)

Ptychoparia ? *linnarssoni* Walcott (part), U. S. Geol. Surv. Monogr. 8, p. 47, pl. 9, fig. 18a, 1884. (Not 18 = *E. lata*.)

Alokistocare linnarssoni Walcott (part), Smithsonian Misc. Coll., vol. 64, no. 3, p. 185, pl. 25, fig. 7, and possibly the cheek inset in fig. 7a, 1916. (Not 7a = *E. lata*.) The best cranidium was not figured.

Middle Cambrian Eldorado; (loc. 58) east side of New York Canyon, Eureka District, Nevada.

Cotypes.—U.S.N.M. no. 24611.

Eldoradia lata, n. sp.

Ptychoparia ? *linnarssoni* Walcott (part), U. S. Geol. Surv. Monogr. 8, p. 47, pl. 9, fig. 18, 1884.

Alokistocare linnarssoni Walcott (part), Smithsonian Misc. Coll., vol. 64, no. 3, p. 185, pl. 25, fig. 7a (heads only), 1916.

This species differs from *E. linnarssoni* in its wider fixed cheeks. Occurrence same as *E. linnarssoni* (loc. 58a).

Cotypes.—U.S.N.M. no. 90669.

Eldoradia prospectensis (Walcott)

Ptychoparia ? *prospectensis* Walcott, U. S. Geol. Surv. Monogr. 8, p. 46, pl. 9, fig. 20, 1884; U. S. Geol. Surv. Bull. 30, p. 202, pl. 27, fig. 5, 1886.

Alokistocare prospectense Walcott, Smithsonian Misc. Coll., vol. 64, no. 3, p. 186, pl. 25, fig. 8, 1916.

Middle Cambrian, Eldorado; (loc. 52a) Prospect Mountain, Eureka District, Nevada.

Holotype.—U.S.N.M. no. 15441.

ELRATHIA Walcott, 1924

Elrathia Walcott, Smithsonian Misc. Coll., vol. 75, no. 2, p. 56, 1924; idem, no. 3, p. 87, 1925.

Already species have been referred to *Elrathia* improperly, as they formerly were to *Ptychoparia*, consequently great care must be exercised to prevent this name also becoming a "dumping ground." These forms have what might be called the "median" structure of the trilobite, consequently many genera are close to one another.

Genotype.—*Conocorphe* (*Conocephalites*) *kingii* Meek.

Range.—Likely confined to the Middle Cambrian.

ADDITIONAL SPECIES REFERRED TO ELRATHIA

Elrathia candace (Walcott)

Ptychoparia candace Walcott, Smithsonian Misc. Coll., vol. 67, no. 2, p. 28, pl. 6, figs. 3, 3a, 1917.

Middle Cambrian, Gordon; (loc. 4v) Gordon Creek, Powell County, Montana.

Cotypes.—U.S.N.M. nos. 63738, 63739.

Elrathia pylas (Walcott)

Ptychoparia pylas Walcott (part), Smithsonian Misc. Coll., vol. 67, no. 2, p. 33, pl. 6, figs. 4, 4a, 1917. (Not 4b = *Alokistocare charax*; 4c = *A. gordonensis*.)

Middle Cambrian, Gordon; (loc. 4q) between Gordon and Youngs Creeks, Powell County, Montana.

Cotypes.—U.S.N.M. nos. 63740, 63741.

Elrathia haguei (Hall and Whitfield)

Crepicephalus (Loganellus) haguei Hall and Whitfield, U. S. Geol. Expl. 40th Parallel, vol. 4, p. 210, pl. 2, figs. 14, 15, 1877.

Ptychoparia haguei Walcott, U. S. Geol. Surv. Bull. 10, p. 36, pl. 6, fig. 6, 1884.

Species must be confined to the locality given below.

Middle Cambrian, Eldorado; Pogonip Mountain, White Pine District, Nevada.

Holotype.—U.S.N.M. no. 24660.

EUREKIA Walcott, 1924

Eurekia Walcott, Smithsonian Misc. Coll., vol. 75, no. 2, p. 56, 1924; idem, no. 3, p. 90, 1925.

Genotype.—*E. granulosa* Walcott.

Range.—Late Upper Cambrian.

Previously the genus contained five species:

Eurekia granulosa Walcott

Eurekia eos (Hall)

Eurekia angustifrons (Walcott)

Eurekia binodosa (Hall)

Eurekia dissimilis (Walcott)

ADDITIONAL SPECIES REFERRED TO EUREKIA

***Eurekia denticulata* (Meek)**

Proctus (Phaeton) denticulatus Meek, Rep. U. S. Geol. Expl. 40th Parallel, vol. 4, pt. 1, p. 49, pl. 1, fig. 10, 1877.

Originally assigned to the Devonian.

Upper Cambrian, Hamburg; drift west side of Steptoe Valley, Nevada (float).

Holotype.—U.S.N.M. no. 14579.

***Eurekia finkelnburgi* (Clark)**

Bayfieldia finkelnburgi Clark, Bull. Amer. Pal., vol. 10, no. 41, p. 32, pl. 4, fig. 7, 1924.

Upper Cambrian, Norwalk sandstone; Osceola Mills, Wisconsin.

Holotype.—M.C.Z. no. 1712.

ETERASPIS, n. gen.

Diagnosis.—Cranidium strongly arched longitudinally. Glabella poorly defined; without furrows. Neck ring thickened; occipital furrow very shallow. Brim about one-third length of glabella; wide rim separated by shallow anterior furrow. Eyes moderate in size and moderately bowed, situated about middle of cranium.

Pygidium flat. Axis defined by shallow dorsal furrow, but chiefly by arching above pleural lobes; extends to border. Pleural furrows faintly outlined. Border flattened.

Genotype.—*Ptychoparia laeviceps* Walcott.

Range.—Middle Cambrian.

Name.—Ετερος = another; ασπίς = shield.

Eteraspis laeviceps (Walcott)

Ptychoparia laeviceps Walcott, U. S. Geol. Surv. Monogr. 8, p. 54, pl. 10, fig. 17, 1884. (Not 18 = *Ehmania oweni*?)

Middle Cambrian, Eldorado; (loc. 58) east side Secret Canyon, Eureka District, Nevada.

Holotype and paratypes.—U.S.N.M. no. 24614.

GLOSSOPLEURA Poulsen, 1927

Glossopleura Poulsen, Meddels. Grønland, vol. 70, p. 268, 1927.

Diagnosis.—Cephalon and pygidium large, of about equal size. Glabella wide, extending to anterior margin, where a narrow upturned brim may sometimes be present; glabella sometimes expands somewhat forward of the eyes; four faint pairs of glabellar furrows usually traceable. Fixed cheeks small; eyes large, situated well back. Free cheeks rather wide with a broad rim when the wide doublure is impressed on them, otherwise sloping smoothly to margin.

Thorax has seven segments.

Pygidium usually has the axis well defined. Axial furrows often faint; pleural furrows faint but clearly traceable in some species to outer edge; wide rim sometimes definite, when doublure is impressed on test.

Genotype.—*Dolichometopus boccar* Walcott.

Comparisons.—*Glossopleura*, as pointed out by Poulsen, resembles *Anoria* in the number of thoracic segments and the extension of the glabella to the front margin, but differs in having longer eyes. However, his observation that *Glossopleura* lacks the macropleural development of the fifth thoracic segment does not hold if the present specific references are all correct.

From the other members of the family *Glossopleura* it is distinguishable by its less developed furrows, the absence of a brim on the cephalon, and the large size and posterior position of the eyes.

Range.—Apparently confined to the Middle Cambrian of Greenland, the Appalachians, and the Rocky Mountains. Frequently the species of this genus constitute the entire fauna, except that an *Alokistocare* may go with it.

DESCRIBED SPECIES REFERRED TO GLOSSOPLEURA

The four species from Greenland described by Poulsen appear to be typical of the genus.

Glossopleura boccar (Walcott)

Dolichometopus boccar Walcott (part), Smithsonian Misc. Coll., vol. 64, no. 5, p. 363, pl. 52, fig. 1a, 1c, 1e, 1916. (Not fig. 1 = *G. stephenensis*; fig. 1b = *G. bosworthensis*; figs. 1d, 1f = *G. nitida*.)

Glossopleura boccar Poulsen, Meddels. Grønland, vol. 70, p. 268 (gen. ref.), 1927.

It appears that four species are represented among the figured specimens of *D. boccar*, consequently one form must be chosen as the species, in order that the genotype of *Glossopleura* can be understood. Keeping in mind Walcott's habit of always writing the type locality first, and the statement he makes on page 363 that *D. boccar* is from the Mount Bosworth section, we may at once conclude that the latter is the type locality and hence choose the types of *D. boccar* from the illustrated specimens of locality 57g. This leads us to use figures 1a, 1c, 1e, as the cotypes of *G. boccar*. Figure 1a shows the cranidial features imperfectly, first, because in the specimen the frontal extension of the glabella is bent down by rock folding, and second, the photograph was cut off too short. Examination of the specimen, however, reveals that its glabella is essentially like that of Figure 1c.

The specimens not illustrated from other localities referred to the species with more or less reservation represent new forms. Numerous unworked collections have been made from this zone, and it is possible that the species may be found in them, but a cursory study indicates that most belong to new forms.

Description.—Head and tail of even size, semicircular in outline. Glabella nearly rectangular, but slightly constricted behind the center; glabellar furrows faint. Fixed cheeks practically confined to the palpebral lobes; none in front of the eyes. Eyes long and situated far back.

Thorax with seven segments.

Pygidial axis rather high and well marked by the dorsal furrow. Five or six axial furrows distinguishable. Doublure wide, and when pressed against test, makes a well-defined border; otherwise the pleural lobes slope rather steeply down to the margin all around. Pleural furrows traceable but not deep.

Middle Cambrian, Stephen; (loc. 57g) Mount Bosworth, British Columbia.

Cotypes.—U.S.N.M. nos. 62703, 62705, 62707.

Glossopleura bosworthensis, n. sp.

Dolichometopus boccar Walcott (part), Smithsonian Misc. Coll., vol. 64, no. 5, p. 363, fig. 1*b* only, 1916. (See preceding, *G. boccar*.)

Several cranidia and a hypostoma appear to constitute another species. Compared with *G. boccar*, the glabella is even more nearly rectangular, the eyes slightly longer and directed more outward.

Occurrence same as *G. boccar*.

Holotype.—U.S.N.M. no. 62704.

Glossopleura nitida, n. sp.

Dolichometopus boccar Walcott (part), Smithsonian Misc. Coll., vol. 64, no. 5, p. 363, pl. 52, figs. 1*d* and 1*f* only, 1916. (See preceding, *G. boccar*.)

Cranidia of this species are much shorter than the others formerly referred to *G. boccar*. The hypostoma is placed with the illustrated pygidium because its surface ornamentation is similar.

Occurrence same as *G. boccar*.

Holotype.—U.S.N.M. no. 62708; paratype, no. 62706.

Glossopleura stephenensis, n. sp.

Dolichometopus boccar Walcott (part), Smithsonian Misc. Coll., vol. 64, no. 5, p. 363, pl. 52, fig. 1 only, 1916. (See preceding, *G. boccar*.)

Only this one impression representing the genus has been found among the thousands of specimens collected from the Mount Stephen fossil bed. Unfortunately, it is not well preserved.

Comparisons.—Compared with *D. boccar*, to which it had been referred, this species has a shorter glabella without glabellar furrows, and the dorsal furrow is more curved, causing greater expansion of the glabella at both ends. In the tail axial and pleural furrows are practically absent.

Middle Cambrian, Stephen; (loc. 145) Mount Stephen, near Field, British Columbia.

Holotype.—U.S.N.M. no. 62702.

Glossopleura producta (Hall and Whitfield)

Ogyia producta Hall and Whitfield, U. S. Geol. Expl. 40th Parallel, vol. 4, p. 244, pl. 2, figs. 31-34, 1877.

Bathyriscus productus Walcott (part), U. S. Geol. Surv. Bull. 30, p. 217, pl. 30, fig. 1*f* and composite from two localities, 1*i*, 1886. (Not 1*c*, 1*d* = *G. piochensis*; 1 = *G. parabola*; 1*a*, 1*g*, 1*h* = *Anoria utahensis*; 1*b* = *G. utahensis*.)

Dolichometopus productus Walcott (part), Smithsonian Misc. Coll., vol. 64, no. 5, p. 369, pl. 53, figs. 2-2*c* only (all copies of originals), 1916.

Many species have been referred to this form. Every occurrence except unquestioned Ophir shale can be eliminated without examination.

Middle Cambrian, Ophir, East Canyon, and (loc. 3c) Ophir, Oquirrh range, Utah.

Cotypes.—U.S.N.M. nos. 15456, 15459.

Glossopleura parabola (Hall and Whitfield)

Ogygia parabola Hall and Whitfield, U. S. Geol. Expl. 40th Parallel, vol. 4, p. 245, pl. 2, fig. 35, 1877.

Bathyriscus productus Walcott (part), U. S. Geol. Surv. Bull. 30, p. 217, pl. 30, fig. 1e only, 1886. (See *G. producta*.)

Dolichometopus productus Walcott (part), Smithsonian Misc. Coll., vol. 64, no. 5, p. 369, pl. 53, figs. 2d only (copy of original figure), 1916.

This is a good species and should not have been included with *G. producta*.

Occurrence same as preceding.

Holotype.—U.S.N.M. no. 15456d.

Glossopleura packi, n. sp.

Bathyriscus productus Walcott (part), U. S. Geol. Surv. Bull. 30, p. 217, pl. 30, figs. 1c, 1d only, 1886. (See *G. producta*.) Figures copied in Smithsonian Misc. Coll., vol. 64, no. 5, pl. 53, figs. 3-3b, 1916.

Bathyriscus productus Pack, Journ. Geol., vol. 14, p. 297, pl. 2, figs. 3-3b, 1906. (Also 4b which he assigned to *Alokistocare piochensis*.)

The cranidium of this species differs from *G. producta* in having slightly smaller eyes and a wider glabella. On the other hand the pygidium of *G. packi* is close to *G. parabola* and if we had the cephalon of the latter, it also might be very similar. From *G. parabola*, the new species differs chiefly in a more circular outline, a slightly wider axis, and a relatively narrower doublure.

Middle Cambrian, Chisholm; (loc. 31) 3 miles northwest of Pioche, Nevada.

Holotype and paratypes.—U.S.N.M. no. 15455.

Glossopleura belesis (Walcott)

Bathyriscus belesis Walcott, Smithsonian Misc. Coll., vol. 64, no. 5, p. 338, pl. 50, figs. 1-11, 1916.

Middle Cambrian, Gordon; (loc. 4v) 6 miles up Gordon Creek, Lewis and Clarke County, Montana.

Cotypes.—U.S.N.M. nos. 62667-76.

Glossopleura bion (Walcott)

Dolichometopus bion Walcott, Smithsonian Misc. Coll., vol. 64, no. 5, pl. 52, figs. 2-2c, 1916.

There is some hesitation to placing this form in *Glossopleura*, but the pygidium is altogether typical as are also the eyes and palpebral lobes. The difference lies in the slightly concave brim and expanding glabella.

Middle Cambrian, Spence; (loc. 55c) Liberty Canyon, west of Montpelier, Idaho.

Cotypes.—U.S.N.M. nos. 62709-62712.

Glossopleura utahensis, n. sp.

Bathyriscus productus Walcott (part), U. S. Geol. Surv. Bull. 30, p. 217, pl. 30, figs. 1, 1b, 1886.

Bathyriscus anax Walcott (part), Smithsonian Misc. Coll., vol. 64, no. 5, p. 335, pl. 48, fig. 1b, 1916.

Besides the figured head and cheek numerous other cranidia as well as pygidia are on hand.

Middle Cambrian, Ophir; (loc. 30a) 1 mile below Argenta, Cottonwood Creek, Wasatch Range, Utah.

Holotype and paratypes.—U.S.N.M. no. 62641.

Glossopleura mckeei, n. sp.

Dolichometopus productus Walcott (not Hall and Whitfield), Smithsonian Misc. Coll., vol. 64, no. 5, p. 369, pl. 53, figs. 4, 4a, 1916.

Dolichometopus tontoensis Walcott (part), idem, pl. 51, figs. 1d', 1d'', 1h (others *Anoria tontoensis*).

Compared with *G. producta*, this species has a wider glabella, which expands forward somewhat faster and the pygidium lacks the pleural furrows and has much weaker axial furrows. In this respect it is more like *G. parabola*.

The specific name is in recognition of the splendid work the present Park Naturalist Edwin D. McKee is doing at the Grand Canyon.

Middle Cambrian, Bright Angel; (loc. 74e) Indian Garden Springs and (loc. 74) Nankoweap Basin, Grand Canyon, Arizona.

Glossopleura buttsi, n. sp.

Dolichometopus ? productus Butts (not Hall and Whitfield), Geol. Surv. Alabama, Spec. Rep. 14, pl. 5, figs. 8, 12, 17, 18, 1926.

This species differs from *G. producta* in having shorter cranidium and pygidium.

Middle Cambrian, Conasauga; Aldrich, Alabama.

Cotypes.—U.S.N.M. no. 90169.

Glossopleura alabamensis, n. sp.

Dolichometopus ? productus Butts, Geol. Surv. Alabama, Spec. Rep. 14, pl. 5, figs. 6, 7, 10, 11, 13-16, 1926.

Compared with *G. buttsi*, this species has a smaller eye and less fusion of the pleura in the tail.

Middle Cambrian, Conasauga; 3 miles west of Talladegea, Alabama.

Cotypes.—U.S.N.M. no. 90170.

Glossopleura lodensis (Clark)

Bathyriscus howelli lodensis Clark, Univ. California Publ., Bull. Dep. Geol. Sci., vol. 13, p. 6, 1921.

Dolichometopus ? lodensis Resser, Smithsonian Misc. Coll., vol. 81, no. 2, p. 10, pl. 3, fig. 9, 1928.

Middle Cambrian; Marble Mountains, Mohave Desert, California.

Holotype.—U.S.N.M. no. 78400.

Glossopleura mohavensis, n. sp.

Dolichometopus ? productus Resser, Smithsonian Misc. Coll., vol. 81, no. 2, p. 10, pl. 3, fig. 9, 1928.

Occurrence same as preceding.

Holotype.—On U.S.N.M. no. 78400.

GLYPHASPIS Poulsen, 1927

Glyphaspis Poulsen, Meddels. Grønland, vol. 70, p. 273, 1927.

Poulsen described a species from Greenland, which may have to be referred to another genus.

Comparisons.—As stated by Poulsen this genus differs from *Asaphiscus* in having genal spines, long-pointed pleura, and a broad, furrowed pygidium, the pleural furrows of which are continued into the concave border.

Genotype.—*Asaphiscus? capella* Walcott.

Range.—Middle Cambrian.

DESCRIBED SPECIES REFERRED TO GLYPHASPIS**Glyphaspis capella (Walcott)****Genotype**

Asaphiscus ? capella Walcott, Smithsonian Misc. Coll., vol. 64, no. 5, p. 385, pl. 59, figs. 2-2c, 1916.

Glyphaspis capella Poulsen, Meddels. Grønland, vol. 70, p. 273, 1927.

Middle Cambrian; (loc. 54z) Half Moon Pass, Big Snowy Mountains, Montana.

Cotypes.—U.S.N.M. nos. 62761-4.

Glyphaspis calenus (Walcott)

Asaphiscus calenus Walcott, Smithsonian Misc. Coll., vol. 64, no. 5, p. 384, pl. 60, figs. 1-1c, 1916.

Middle Cambrian, Meagher; (loc. 5f) 11 miles south of Neilhart, and Dry Creek, East Gallatin River, Montana.

Cotypes.—U.S.N.M. nos. 62765-62768.

Glyphaspis camma (Walcott)

Asaphiscus camma Walcott, Smithsonian Misc. Coll., vol. 64, no. 5, p. 384, pl. 60, figs. 2-2c, 1916.

Middle Cambrian, Meagher ; (loc. 4g) 5 miles northeast of Logan, Montana.

Cotypes.—U.S.N.M. nos. 62769-62772.

Glyphaspis ? montanensis (Whitfield)

Crepicephalus (Loganellus) montanensis Whitfield, Ludlow's Rep. Recon. Yellowstone Nat. Park, War Dep., p. 141, pl. 1, figs. 1, 2, 1876.

Specimen too poor to be sure of generic position.

Middle Cambrian, Meagher ; near Fort Logan, 18 miles northwest of White Sulphur Springs, Montana.

Holotype.—U.S.N.M. no. 90668.

IDAHOIA WALCOTT, 1924

Idahoia Walcott, Smithsonian Misc. Coll., vol. 75, no. 2, p. 58, 1924 ; idem, no. 3, p. 94, 1925.

Genotype.—*I. serapio* Walcott.

Range.—Middle Upper Cambrian.

ADDITIONAL SPECIES REFERRED TO IDAHOIA

Idahoia wisconsinensis (Hall)

Conocephalites wisconsinensis Hall, 16th Ann. Rep. New York State Cab. Nat. Hist., p. 164, pl. 7, figs. 39, 41 ; pl. 8, figs. 22-24, 27, 28, 1863.

Saratogia wisconsinensis Walcott, Smithsonian Misc. Coll., vol. 64, no. 3, p. 198, pl. 34, figs. 5-5c, 1916.

Upper Cambrian, Franconia ; Trempealeau and other localities in Wisconsin.

Cotypes.—A.M.N.H.

Idahoia latifrons (Hall)

Conocephalites latifrons Hall, 16th Ann. Rep. New York State Cab. Nat. Hist., p. 122, pl. 7, fig. 40, 1863.

This form is a good species.

Upper Cambrian, Franconia ; Trempealeau, Wisconsin.

Holotype.—Presumably lost.

Idahoia hamulus (Owen)

Lonchocephalus hamulus Owen, Rep. Geol. Surv. Wisconsin, Iowa, Minnesota, p. 576, pl. 1A, figs. 8, 12, 1852.

Conocephalites hamulus Hall, 16th Ann. Rep. New York State Cab. Nat. Hist., p. 166, pl. 7, figs. 43, 44 ; pl. 8, figs. 25, 26, 1863.

Saratogia hamulus Walcott, Smithsonian Misc. Coll., vol. 64, no. 3, p. 196, 1916.

Upper Cambrian, Franconia ; Minneiska, Minnesota ; Trempealeau and other localities in Wisconsin.

Cotypes.—Original types destroyed ; plesiotypes, A.M.N.H. no. 315.

Idahoia hera (Walcott)

Saratogia hera Walcott, Smithsonian Misc. Coll., vol. 64, no. 3, p. 197, pl. 35, figs. 3-3b, 1916.

Upper Cambrian, Franconia; Marine Mills, Minnesota.

Cotypes.—U.S.N.M. nos. 61715-6.

INGLEFIELDIA Poulsen, 1927

Inglefieldia Poulsen, Meddels. Grønland, vol. 70, p. 261, 1927.

This genus is closely allied to *Kochiella*, differing chiefly in having a wider rim and lacking the double impression. The rim in turn has the backward expansion opposite the center of the glabella. Pygidium unknown.

Genotype.—*I. porosa* Poulsen.

Range.—Upper portion of Lower Cambrian. At present no Middle Cambrian species have been determined.

Inglefieldia porosa Poulsen

scribed as *Chancia*

Inglefieldia planilimbata Poulsen

Inglefieldia thia Poulsen (not Walcott's species)

Inglefieldia groenlandica Poulsen

(not Walcott's species)

Inglefieldia inconspicua Poulsen

Inglefieldia affinis Poulsen = new

Inglefieldia discreta Poulsen

genus.

Inglefieldia venulosa (Poulsen), de-

KOCHASPIS, n. gen.

Numerous species referred to several genera, particularly to *Crepicephalus*, when the pygidia were known, appear to be closely allied to *Kochiella*.

Diagnosis.—Cranidium wide. Glabella wide, tapering, clearly defined, with two or more pairs of furrows. Brim wide, divided into two subequal parts by anterior furrow which is shallow in the center; rim clearly defined. Fixed cheeks two-thirds width of glabella; eye lines heavy; eyes rather small, situated at about the mid point of cranidium. Free cheeks extended into long genal spines.

Pygidium with large prominent axis. Pleural furrows strong; pleural lobes drawn out into spines.

Surface granulose, lined or both.

Genotype.—*Crepicephalus liliana* Walcott.

Range.—Late Lower and Middle Cambrian.

DESCRIBED SPECIES REFERRED TO KOCHASPIS

Kochaspis liliana (Walcott)

Crepicephalus liliana Walcott (part), U. S. Geol. Surv. 30, p. 207, pl. 28, figs. 3, 3a, 1886. (Not 3b, 3c = *K. highlandensis*); 10th Ann. Rep. U. S. Geol. Surv., p. 653, pl. 96, figs. 7, 7a, 1890; Smithsonian Misc. Coll., vol. 64, no. 3, p. 209, pl. 29, figs. 5, 5a, 1916.

Careful separation of the specimens identified as this and other species according to locality necessitates a realignment.

Lower Cambrian, Pioche; (loc. 31a) Panaca Road, southeast of Pioche, Nevada.

Cotypes.—U.S.N.M. no. 15428.

Kochaspis augusta (Walcott)

Crevicephalus augusta Walcott (part), U. S. Geol. Surv. Bull. 30, p. 208, pl. 28, fig. 2a, 1886. (Not 2 = *K. nevadensis*; 2b = another genus.)

Locality same as preceding.

Holotype.—U.S.N.M. no. 15430.

Kochaspis nevadensis, n. sp.

Crevicephalus augusta Walcott (part), U. S. Geol. Surv. Bull. 30, p. 207, pl. 28, fig. 2, 1886. (See preceding.)

Published figures exaggerate the narrowness which characterizes this species.

Lower Cambrian, Pioche formation; (loc. 30) 8 miles north of Bennetts Spring, Highland Range, Nevada.

Holotype.—U.S.N.M. no. 61643.

Kochaspis highlandensis, n. sp.

Crevicephalus liliana Walcott (part), U. S. Geol. Surv. Bull. 30, p. 208, pl. 28, figs. 3b, 3c, 1886. (See preceding.)

Rim on published figure drawn too concave. Pygidium like *K. augusta* but with narrower axis.

Occurrence same as preceding.

Cotypes.—U.S.N.M. nos. 61640-1.

Kochaspis cecinna (Walcott)

Crevicephalus cecinna Walcott, Smithsonian Misc. Coll., vol. 67, no. 3, p. 99, pl. 11, figs. 1, 1a, 1917.

Lower Cambrian, Mount Whyte; (loc. 63a) Ptarmigan Peak, 5½ miles northeast of Lake Louise, Alberta.

Cotypes.—U.S.N.M. nos. 64365-6.

Kochaspis celer (Walcott)

Crevicephalus celer Walcott, Smithsonian Misc. Coll., vol. 67, no. 3, p. 101, pl. 11, fig. 2, 1917.

Ptychoparia clusia Walcott, idem, pl. 11, fig. 3.

Middle Cambrian, Ptarmigan; (loc. 58k) Mount Stephen, 3 miles east of Field, British Columbia.

Holotype.—U.S.N.M. no. 64367; paratype, no. 64368.

Kochaspis chares (Walcott)

Crevicephalus chares Walcott, Smithsonian Misc. Coll., vol. 67, no. 2, p. 35, pl. 6, figs. 5-5c, 1917.

Cranidium may belong to another species.

Middle Cambrian, Ptarmigan; (loc. 63d) east base Ptarmigan Peak, 5½ miles northeast of Lake Louise, Alberta.

Cotypes.—U.S.N.M. nos. 63744-6.

Kochaspis ? gogensis (Walcott)

Ptychoparia gogensis Walcott, Smithsonian Misc. Coll., vol. 67, no. 3, p. 88, pl. 12, figs. 4, 4a, 1917.

Lower Cambrian, Mount Whyte; (loc. 62w) above Gog Lake, Wonder Pass, British Columbia.

Holotype.—U.S.N.M. no. 64386.

Kochaspis carina (Walcott)

Ptychoparia carina Walcott, Smithsonian Misc. Coll., vol. 67, no. 3, p. 80, pl. 13, fig. 6, 6a, 1917.

Middle Cambrian, Ptarmigan; (loc. 35m) 3 miles southwest of head of Lake Louise, Alberta.

Holotype.—U.S.N.M. no. 64400.

Kochaspis upis (Walcott)

Crepicephalus upis Walcott, Smithsonian Misc. Coll., vol. 64, no. 3, p. 218, pl. 33, figs. 4-4d, 1916.

Middle Cambrian, Gordon Mountain; (loc. 150b) Chinese Wall, South Fork, White River-Indian Creek Pass, Montana.

Lectotype.—U.S.N.M. no. 61697; paratypes, nos. 61695, 61696, 61698.

Kochaspis unzia (Walcott)

Crepicephalus unzia Walcott (part), Smithsonian Misc. Coll., vol. 64, no. 3, p. 217, pl. 34, fig. 7a, 1916. (Not 7 = undescribed genus.)

Occurrence same as preceding.

Holotype.—U.S.N.M. no. 61706.

KOCHIELLA Poulsen, 1927

Kochiella Poulsen, Meddels. Grønland, vol. 70, p. 259, 1927.

We are here dealing with a group of trilobites which developed greatly in late Lower Cambrian time, continuing into the Middle Cambrian. Aside from the two genera made by Poulsen, this group has long needed complete revision. Even now the final word cannot be said.

Diagnosis.—Trilobites with wide cranidia. Glabella clearly defined, with three pairs of furrows usually developed. Brim wide flat or concave, with a narrow rim faintly outlined; conspicuous feature of brim is impression of doublure on upper surface, which simulates a

wide rim bent back toward the glabella at the middle. Fixed cheeks wide, eye lines heavy; eyes moderate in size and situated rather far back. Free cheeks greatly expanded at genal angles, flat or concave in the outer portion and with long, wide genal spines.

Pygidium with wide axis. Pleural furrows well defined and pleural lobes extended into spines.

Surface usually with scattered granules often of more than one size.

Owing to the width of the fixed cheeks, some species were referred to *Olenopsis*, while those for which the pygidium was known were placed in *Crepicephalus*.

Genotype.—*K. tuberculata* Poulsen.

Range.—Later Lower Cambrian, extending into Middle Cambrian.

DESCRIBED SPECIES REFERRED TO KOCHIELLA

Besides the species discussed below, there are *K. propinqua* Poulsen, *K. arcana* Poulsen, and *K. gracilis* Poulsen.

Kochiella tuberculata Poulsen

Kochiella tuberculata Poulsen, Meddels. Grønland, vol. 70, p. 259, pl. 15, figs. 7-13, 16, 1927.

Crepicephalus cf. *cecinna* Poulsen, Meddels. Grønland, vol. 70, p. 267, pl. 16, figs. 17, 18, 1927.

There can be but little doubt that this pygidium represents a species of *Kochiella*.

Lower Cambrian, Cape Kent; Cape Kent, North Greenland.

Cotypes.—Min. Mus. Copenhagen.

Kochiella crito (Walcott)

Olenopsis crito Walcott, Smithsonian Misc. Coll., vol. 67, no. 3, p. 75, pl. 11, fig. 6-6b, 1917.

Lower Cambrian, Mount Whyte; (loc. 60e) Ptarmigan Lake Pass, Alberta.

Lectotype.—U.S.N.M. no. 64371; paratypes, nos. 64372-3.

KOCHINA, n. gen.

Certain Middle Cambrian species resemble *Kochiella*, but all differ in the same manner and therefore are regarded as a distinct genus.

Comparisons.—*Kochina* differs from *Kochiella* in three respects: First, the brim is narrower so that the preglabellar area is practically eliminated; second, the converging course of the anterior facial suture greatly reduces the area of brim at the anterior angles; and third, the eyes have a more anterior position.

Genotype.—*Olenopsis americanus* Walcott.

Range.—Thus far confined to the Albertella zone of the Middle Cambrian.

DESCRIBED SPECIES REFERRED TO KOCHINA

Kochina americana (Walcott)

Olenopsis americanus Walcott, Smithsonian Misc. Coll., vol. 57, no. 8, p. 243, pl. 36, figs. 8-11, 1912.

Middle Cambrian, Gordon; (loc. 4v) Gordon Creek, Montana.

Cotypes.—U.S.N.M. nos. 58368-71.

Kochina bosworthensis, n. sp.

Olenopsis cf. *americanus* Walcott, Smithsonian Misc. Coll., vol. 67, no. 2, p. 37, pl. 6, fig. 8-8b, 1917.

Middle Cambrian, Ptarmigan; Mount Bosworth (loc. 35c) and Popes Peak, above Ross Lake (loc. 63j), British Columbia.

Lectotype.—U.S.N.M. no. 63749; paratype, nos. 63450-1.

MACELLOURA, n. gen.

Diagnosis.—Cranidium quadrate, facial sutures diverge anterior to eye, making sharp, salient, down-turned anterior angles; postero-lateral limbs short. Glabella quadrate, tapering but slightly; extends to anterior margin; without glabellar furrows; wide. Fixed cheeks one-fourth width of glabella; eyes rather small.

Pygidium spade-shaped with anterior pleural furrows making up-turned sides; dorsal furrow marked only by change in slope; axial and pleural lacking; axis tapering rapidly, half as long as pygidium. Free cheeks and thorax not known.

Genotype.—*Iliaenurus* ? *dia* Walcott.

Name.—Μακελλα = spade; ουρα = tail.

Range.—About middle Upper Cambrian, or somewhat younger.

Macelloura dia (Walcott)

Iliaenurus ? *dia* Walcott, Proc. U. S. Nat. Mus., vol. 13, p. 277, pl. 20, fig. 6, 1890.

Nileus ? *dia* Walcott, Smithsonian Misc. Coll., vol. 57, no. 13, p. 359 (gen. ref.), 1914.

Upper Cambrian, Wilberns; (loc. 70a) Morgans Creek, Burnet County, Texas.

Cotypes.—U.S.N.M. no. 23865.

METEORASPIS, n. gen.

Diagnosis.—Cranidium but little larger than glabella. Glabella large; dorsal furrow well defined; without glabellar furrows. Occipital

furrow and rim well developed. Brim about one-third as wide as glabella is long; heavy, thickened, up-turned rim separated by strong anterior furrow; preglabellar area almost obsolete in front of glabella. Fixed cheeks narrow, consisting entirely of the strongly arched palpebral lobes and apparently narrow straps. Eyes rather large.

Genotype.—*Ptychoparia* ? *metra* Walcott.

Range.—Middle Upper Cambrian.

Name.—Μετροπος = high; ασπς = shield.

Meteoraspis metra (Walcott)

Ptychoparia ? *metra* Walcott, Proc. U. S. Nat. Mus., vol. 13, p. 273, pl. 21, fig. 7, 1890.

Upper Cambrian, Wilberns; (loc. 67) Potatotop, 7 miles northwest of Burnet and (loc. 68) Packsaddle Mountain, 11 miles southeast of Llano, Texas.

Holotype.—U.S.N.M. no. 23858.

MODOCIA Walcott, 1924

Modocia Walcott, Smithsonian Misc. Coll., vol. 75, no. 2, p. 59, 1924; idem, no. 3, p. 106, 1925.

Genotype.—*Arionellus (Crepicephalus) oweni* Meek and Hayden.

Range.—Upper Cambrian.

DESCRIBED SPECIES REFERRED TO MODOCIA

Modocia oweni (Meek and Hayden)

Arionellus (Crepicephalus) oweni Meek and Hayden, Proc. Acad. Nat. Sci. Philadelphia, 1861, p. 436.

Modocia oweni Walcott (part), Smithsonian Misc. Coll., vol. 75, no. 2, p. 59, pl. 12, figs. 1, 2, 1924; idem, no. 3, p. 106, pl. 16, figs. 1, 2, (not 3 = *M. centralis*), 1925. (Not *Ptychoparia oweni* Walcott = *Ehmania oweni*.)

This trilobite was referred by various authors to *Agraulos*, *Ptychoparia*, and *Crepicephalus*. Also several other species were included under this name. Study of the types shows that the species occurs only at the locality given below.

Upper Cambrian, Deadwood; head of Powder River, Big Horn Mountains, Wyoming.

Holotype.—U.S.N.M. no. 1180.

Modocia centralis (Whitfield)

Crepicephalus (Loganellus) centralis Whitfield, Prelim. Rep. Pal. Black Hills, U. S. Geol. Surv., p. 10, 1877; Rep. Geol. Res. Black Hills, U. S. Geogr. and Geol. Surv., p. 341, pl. 2, figs. 21-24, 1880.

Modocia oweni Walcott (part), Smithsonian Misc. Coll., vol. 75, no. 2, p. 59, pl. 12, fig. 7, 1924; idem, no. 3, p. 106, pl. 16, fig. 3, 1925.

Upper Cambrian, Deadwood; Castle Creek, Black Hills, South Dakota.

Cotypes.—U.S.N.M. no. 24581.

***Modocia berkeyi*, n. sp.**

Agraulos convexus Berkey, Amer. Geologist, vol. 21, p. 288, pl. 20, figs. 9-11, pl. 21, figs. 3, 7, 1898.

Agraulos convexus var. A. Berkey, idem, pl. 20, figs. 1, 2, pl. 21, fig. 5.

Ptychoparia calymenoides Berkey, idem, pl. 20, figs. 3, 4, pl. 21, fig. 4.

It appears that variety A and the other specimens assigned to the species are alike except for size. However, critical work will have to be done to settle this point. Variety B of Berkey belongs to another genus.

Upper Cambrian, Iron-ton; Taylors Falls, Minnesota.

Holotype.—Columbia Univ. no. 22283; paratypes, nos. 22286, 22307.

***Modocia glomerata* (Walcott)**

Acrocephalites ? *glomeratus* Walcott, Smithsonian Misc. Coll., vol. 64, no. 3, p. 179, pl. 26, figs. 7, 7a, 1916.

This specimen is typical of the genus *Modocia*, departing only in the development of the median boss.

Upper Cambrian, Deadwood; (loc. 340c) near Rawlings, Wyoming.

Holotype.—U.S.N.M. no. 61591.

Moosia Walcott is a synonym of *Elwinia* Walcott (Smithsonian. Misc. Coll., vol. 75, no. 3, p. 88, 1925).

PLAGIURA, n. gen.

Diagnosis.—Cranidium large, smooth, rather flat; facial suture converges slightly anterior to eyes; behind the eyes it diverges rapidly, forming wide, blunt postero-lateral limbs. Brim about one-third as wide as the glabella is long; no rim separated. Fixed cheeks about half width of glabella; eyes small, situated opposite anterior third of the glabella. Free cheeks simple curved bands, with rounded genal angles.

Pygidium triangular, broad, with anterior angles somewhat drawn out; axis wide, well separated by change in slope and extends nearly to rear margin; axial and pleural furrows present.

Genotype.—*Ptychoparia*? *cercops* Walcott.

Range.—Upper Lower Cambrian, Canadian Rockies.

Name.—πλαγιος = slanting; ουρα = tail.

Plagiura cercops (Walcott)

Ptychoparia ? cercops Walcott, Smithsonian Misc. Coll., vol. 67, no. 3, p. 81, pl. 12, figs. 1-1d, 1917.

Lower Cambrian, Mount Whyte; (loc. 63c) 1½ miles northeast of Lake Louise, Alberta.

Cotypes.—U.S.N.M. nos. 64377-64381.

POLIELLA Walcott, 1916

Poliella Walcott, Smithsonian Misc. Coll., vol. 64, no. 5, p. 349, 1916.

This genus was established as a subgenus of *Bathyuriscus*, with the statement that the pygidium was different. Even a cursory revision of the trilobites referred to *Bathyuriscus* and related genera shows the necessity of making this a full genus. Evidently, Walcott first intended to use the form from Pole Creek, *Bathyuriscus powersi*, as the genotype, but since he designated the Spence shale form, it becomes the genotype, and the genus is not represented at the Pole Creek locality.

Diagnosis.—Cephalon much larger than pygidium. Glabella quadrate, expanded anteriorly; two pairs of glabellar furrows usually clearly defined, others very faint or absent. Eyes long, moderately bowed. Brim when present narrow and simple.

Thorax with 7 to 9 segments.

Pygidium with wide, well-defined axis; pleura usually fused; two to four pleural furrows extend to the margin; rim absent.

Comparisons.—Compared with *Bathyuriscus*, *Poliella* is distinguished by its fewer thoracic segments, larger eyes, and much smaller tail.

Genotype.—*Bathyuriscus (Poliella) anteros* Walcott.

Range.—Middle Cambrian.

Species formerly referred to *Poliella*:

P. powersi = *Bathyuriscus* *P. sylla* = *Clavaspidella*
P. probus = *Clavaspidella*

DESCRIBED SPECIES REFERRED TO POLIELLA

Besides the species discussed below, the following belong to the genus.

Poliella anteros Walcott *Poliella chilo* Walcott
Poliella balus Walcott

Poliella occidentalis (Matthew)

Dolichometopus occidentalis Matthew, Trans. Roy. Soc. Canada, 2d ser., vol. 5, sec. 4, p. 49, pl. 2, fig. 2, 1899.

Bathyriscus pupa Matthew, idem, p. 51, pl. 2, fig. 5.

Bathyriscus occidentalis Walcott, Smithsonian Misc. Coll., vol. 53, no. 2, p. 41, 1908. Walcott, Canadian Alpine Journ., vol. 1, pt. 2, pl. 3, fig. 2, 1908.

Bathyriscus (Poliella) occidentalis Walcott, Smithsonian Misc. Coll., vol. 64, no. 5, p. 351, pl. 46, fig. 3, 1916.

Owing to the poor preservation of the holotype, this species would be inadequately represented except that two excellent carapaces have just been discovered in our collections. It seems that the pygidium fits *Poliella*. The published figures are restored more than warranted.

Middle Cambrian, Stephen; (loc. 14s) Mount Stephen, near Field, British Columbia.

Holotype.—Royal Ontario Museum (casts U.S.N.M. no. 62621).

Poliella prima (Walcott)

Bathyriscus (Poliella) primus Walcott (part), Smithsonian Misc. Coll., vol. 64, no. 5, p. 352, pl. 46, figs. 6, 6a, 6b, 1916. (Not 6c, d = *P. castlensis*.)

This is described as a Lower Cambrian species but belongs to the Ptarmigan formation.

Middle Cambrian, Ptarmigan; (locs. 35m, 35e) 3 miles southwest of the head of Lake Louise, Alberta.

Lectotype.—U.S.N.M. no. 62624; paratype no. 62623.

Poliella castlensis, n. sp.

Bathyriscus (Poliella) primus Walcott (part), Smithsonian Misc. Coll., vol. 64, no. 5, p. 352, pl. 46, figs. 6c, d, 1916.

It is necessary to separate this head from *P. prima* because of its wider brim and eyes which have a more divergent position.

Middle Cambrian, Ptarmigan; (loc. 58t) Castle Mountain, Alberta.

Holotype.—U.S.N.M. no. 62626.

Poliella caranus (Walcott)

Bathyriscus (Poliella) caranus Walcott, Smithsonian Misc. Coll., vol. 64, no. 5, p. 350, pl. 46, fig. 5, 1916.

This form barely remains within the genus because of its greatly reduced brim.

Middle Cambrian, Spence; (loc. 55c) Liberty Canyon, west of Montpelier, Idaho.

Holotype.—U.S.N.M. no. 62628.

STROTOCEPHALUS, n. gen.

Diagnosis.—Cranidium alone available. Facial suture diverges anteriorly to rather sharp anterior angles; glabella tapering with faint furrows; occipital furrow shallow; occipital ring slightly thickened. Brim wide, concave, and without a rim, striated vertically; eye lines developed; palpebral lobes of moderate size, situated far back.

Comparisons.—Differs from *Alokistocare* in two points, viz, sharper anterior angles and more posterior position of the eyes.

Genotype.—*S. gordonensis*, n. sp.

Name.—Στροτος = spread, κεφαλος = head.

Range.—At present confined to Middle Cambrian.

Strotocephalus gordonensis, n. sp.

Ptychoparia pylas Walcott (part), Smithsonian Misc. Coll., vol. 67, no. 2, pl. 6, fig. 4c, 1917. (Other figs. *Elrathia*.)

Middle Cambrian, Gordon; (locs. 4q, 4v) Gordon and Youngs Creeks, Ovanda quadrangle, Montana.

Holotype.—U.S.N.M. no. 63743.

WEEKSINA, n. gen.

Two species from the Upper Cambrian of the House Range referred to the Middle Cambrian genus *Asaphiscus* are distinct in many respects.

Diagnosis.—Entire trilobite ovate; convexity not determinable. Facial suture diverges anterior to the eyes and is intramarginal two-thirds of the distance to the center so that the anterior angles are strongly rounded. Glabella wide, rounded in front; glabellar furrows short, but fairly deep. Brim of moderate width; rim thickened and, owing to course of the suture, sharply narrowed toward anterior angles. Fixed cheeks narrow; eyes fairly large; palpebral lobes strongly bowed. Free cheeks with well-defined rim and blunt genal angles.

Thorax with 10 or 12 segments; tips of pleura blunt; long spine on axis of next to last or third from last pleuron.

Pygidium half the size of the cephalon; axis well defined, rather wide, and extending nearly to rear margin; axial and pleural furrows distinct.

Surface granulose.

Genotype.—*Asaphiscus* ? *unispinus* Walcott.

Range.—Presumably early Upper Cambrian.

DESCRIBED SPECIES REFERRED TO WEEKSINA

Weeksina unispina (Walcott)

Asaphiscus ? unispinus Walcott, Smithsonian Misc. Coll., vol. 64, no. 5, p. 389,
pl. 61, fig. 1, 1916.

Upper Cambrian, Weeks ; (loc. 30n) Weeks Canyon, House Range,
Utah.

Holotype.—U.S.N.M. no. 62775.

Weeksina granulata (Walcott)

Asaphiscus ? granulatus Walcott, Smithsonian Misc. Coll., vol. 64, no. 5, p. 385,
pl. 61, figs. 2, 2a, 1916.

Number of thoracic segments uncertain.

Occurrence same as preceding.

Cotypes.—U.S.N.M. nos. 62776-7.

SMITHSONIAN MISCELLANEOUS COLLECTIONS
VOLUME 93, NUMBER 6

EAR EXOSTOSES

(WITH FIVE PLATES)

BY

ALEŠ HRDLIČKA

Curator, Division of Physical Anthropology,
U. S. National Museum



(PUBLICATION 3296)

CITY OF WASHINGTON
PUBLISHED BY THE SMITHSONIAN INSTITUTION
MAY 14, 1935

The Lord Baltimore Press
BALTIMORE, MD., U. S. A.

CONTENTS

	PAGE
Introduction	I
Literature	I
Summary	12
Whites (table)	13
Indians (table)	14
Other races (table).....	15
Clinical material	16
New observations	19
New material	20
Detailed data	23
Age	23
Sex	27
Frequency of exostoses in the two ears.....	28
Side	29
Number	31
Location	33
Size	37
Shapes	39
Symmetry	40
Rate of growth.....	41
Subdivision	42
Structure	46
Nature	47
Etiology	49
True causes "unknown".....	49
"Spontaneous", nutritive	50
Congenital	50
Developmental	51
Inborn tendency	53
Heredity	54
Social status: Occupation.....	57
Climate	58
Food, drink, habits.....	58
Constitutional derangements	59
Gout, arthritic diathesis.....	59
Syphilis	61
Local irritations and inflammation.....	62
Salt water	65
Abscesses, furuncles	66
Polyps	66
Mechanical causes and traumatism.....	66
Head deformation	68

	PAGE
Miscellaneous causes	73
Inbreeding	73
Constitutional diseases (other than syphilis and arthritis)	73
Innervation	74
Connection with exostoses of inner ear, or of other parts of the skeleton	74
Otosclerosis	74
Mastoid	74
Mastication	74
Vestigial	75
No pathology	75
General Discussion	75
Unity of complex	75
Restriction to man	75
Generalization in man	76
Varied frequency	76
General similarity	76
Nature of the process	77
Antiquity	79
Age	80
Sex	80
Social status	81
Side	81
Constitutional diseases, local pathological conditions, traumatism, irri- tations	82
The general cause	82
Summary	85
Bibliography	86
Index of authors	99

EAR EXOSTOSES

BY ALEŠ HRDLIČKA

Curator, Division of Physical Anthropology, U. S. National Museum

(WITH FIVE PLATES)

INTRODUCTION

Few subjects in racial osteopathology have received more attention than that of ear exostoses, and this not only in Whites, but also in the American aborigines.

The term "ear exostoses" is used here for the sake of brevity. Under it are understood all distinct bony excrescences or tumors within the external auditory canal, of whatever form or size, from the eminence, ridge, or "pearl", that can definitely be recognized as an abnormal formation, to the more or less irregular bony masses that in some cases fill almost the whole lumen of the meatus and may even protrude from its mouth.

These growths have received a number of names. They belong to the "enostoses" of Von Rokitansky; Toyabee called them "osteomata", Roosa "hyperplastic osteomata", Steinbrügge "periosteal osteomata". Kessel distinguished hyperostoses, exostoses, periostoses, and osteophytes. Other authors use mostly the terms hyperostoses and exostoses, acknowledging that the two merge into each other. In general, however, as stated by Dahlstrom (1923, p. 217), "these growths have come to be understood as exostoses."

LITERATURE

Bony growths in the auditory canal were doubtless known to medical men long ago, but what seems to be the first printed record of such an abnormality appeared in 1809, when Autenrieth¹ reported a case

¹ Autenrieth, J. H. F., *Arch. Physiol.*, vol. 9, p. 349, Halle, 1809. As the first report, the case deserves perhaps to be cited in full and in the original:

"Bey einem vierzigjährigen Weibe, das sieben Jahre früher eine Hemiplegie der linken Seite erlitten hatte, und im Frühjahr von 1808 an einer Wiederholung des Schlagflusses gestorben war; ihr ganzer Schädel zeigte sich schief, und weiter auf der rechten, als linken Seite, die Jugular-Venen Grube ungewöhnlich weit, links äusserst klein. Die eigentlich Zitzenfortsätze waren gehörig gross und sich einander gleich; aber der rechte knöcherne Gehörgang durch einen

in a white female. In a woman of 40 who died of apoplexy and whose skull showed asymmetry, "the right external meatus was nearly closed, except for a vertical fissure hardly as broad as a line, by a bubblelike bony growth proceeding from the posterior and upper side." The interior of the exostosis was cancellous; and no connection was found between its cellular spaces and those of the mastoid.

In the thirties of the last century these bony growths in the ears were evidently repeatedly encountered by Kramer, who does not, however, clearly differentiate them from polyps. Kramer (1837), says, speaking of polypoid conditions:

These granulations may be either soft, spongy, of a very red colour, vesicular, bleeding readily on the slightest touch, sensitive, covered with copious mucous secretion, pedunculated, or globular; or they may be broad of base, and be of cartilaginous or almost bony hardness, insensible, bleeding little or not at all, and rather of a pale red colour. (P. 107.)

* * * *

One case in particular I cannot avoid here mentioning. A stalactite-shaped growth hung from the superior surface of the meatus, very near the membrana tympani, and was of so remarkable a bony hardness and density, that it was impossible to pierce it even with the sharpest knife. (P. 118.) [This could only have been an ear exostosis.]

Notwithstanding these early reports, the knowledge of bony growths in the ears lags until the middle of the nineteenth century. Von Rokitsansky (1864) lays a broad foundation for the knowledge and differential diagnosis of exostoses, hyperostoses, and osteophytic excrescences of human bones. Toynbee (1855-60) reports nine cases of ear tumors from his practice and discusses ably the whole subject of these exostoses. Von Troeltsch (1862-81) gives due attention to bony growths of the ear, to be followed by Bonnafont (1865-68) and others. Beginning with 1864, these conditions commence to assume also an anthropological importance.

blasenförmigen Knochenauswuchs von der obern und hintern Seite her, bis zu einer in der Mitte kaum linien breiten senkrechten Spalte verschossen. Dieser, einer knöchernen Gehörblase der Thier ähnliche, Knochenauswuchs war durch eine Rinne von den übrigen Theilen des Schlafknochen geschieden, ihnen ganz zellig; doch fanden wir keine Verbindung dieser Luftzellen mit denen des eigentlichen Zitzenfortsatzes; der Gehörgang wurde durch ihn in der Mitte seiner Länge noch mehr zusammengedrückt, als bey seinem Eingang, doch erhielt er gegen die Trommelhöhle zu wieder seine gewöhnliche Weite. Die Substanz des Knochenauswuches selbst war gesund, so wie inneren Theile des Gehörganges waren."

Seligmann (1864),² of Vienna, reports finding ear exostoses in five out of six highland "Inca" skulls with Aymara deformation (four out of five in his 1870 account). All the skulls with the exostoses were males, the remaining one was a female. Seligmann concluded that these abnormalities did not occur in the Peruvian "flat-heads"; that the circular deformation of his specimens was not the cause, for similarly deformed skulls from elsewhere did not show the tumors; that the exostoses were restricted to males above 16 years of age; and that they were caused by an extension of an inflammatory process brought on by irritation due to the piercing of the ears, forceful enlargement of the openings for large ear ornaments, and the carrying of such heavy ornaments—at and after the initiation ceremonies of the Incaic youth.

The next report of anthropological interest on these abnormalities is that of Welcker (1864), who opposes Seligmann's views as to the causation of the tumors.³ He found them in two out of nine crania of Marquesas Islanders of the Barnard Davis collection and also in an undeformed skull of a Fox Indian.

Toynbee (1860) gives the first statistical datum on the frequency of these growths in a given population—in 1,013 diseased ears of the English he found ear exostoses in 14, or 1.03 percent of the temporals.

The year 1874 brings to light the first two American contributions to the subject, one by a physical anthropologist of note, the other by a physician. Jeffries Wyman (1874), Curator of the Peabody Museum, reports having found the exostoses in 8 out of 330 crania from Ancon, Peru; and Blake informs Wyman (Wyman, 1874), that he found the growths in about 5 of 1,000 cases (or 0.5 percent) of American Whites treated for diseases of the ear. There is not much discussion, but Wyman states that the growths "vary in size from a pin's head to that of the whole calibre of the canal."

In his *Thesaurus Craniorum* (London, 1867) and its supplementary volume (1874), J. Barnard Davis refers to the presence of auditory exostoses, among the crania of his collection, in the two skulls reported by Welcker, in another specimen from the Marquesas Islands,

² One or two authors give the credit of the first report of an ear exostosis in an American Indian to Zschokke (*Über eine merkwürdige bisher unbekannte krankhafte Veränderung an Menschenknochen aus Peru. Würzburger Inaug.—Diss., Arau, 1845*), but this author reports on peculiar multiple exostoses in six old Peruvian bones without touching on those of the skull.

³ According to Virchow (*Klin. Wochenschr., 1893, p. 636*), Seligmann himself in later years gave up his former opinion.

in a skull from the Loyalty Islands, in three Kanaka crania from the Sandwich Islands, in the skull of one of the Khas tribe from Nepal, in the skull of an ancient Roman, and in four Peruvian crania belonging to the Quichua Indians (quoted also by Turner, 1878).

Lucien Carr (1878) includes the following notes on ear exostoses in his report on 67 crania from the stone graves in Tennessee: "*Small bony tumors* are found in the outer opening of the ear in seven of the brachycephalic and in two among the flattened skulls of class four; but they are not present in either of the other groups. This percentage, a little more than one in seven, is greater than Professor Wyman found among the Peruvian crania in which it existed one in 41.25, or among Europeans, among whom it is said by Dr. C. J. Blake to be found in about five out of a thousand."

In 1879, in an article on the "Exostoses within the External Auditory Meatus", William Turner reports ear exostoses in a deformed skull from Peru, and also in one of a flat-head Chinook Indian. Seventeen other artificially deformed crania from North and South America were free of exostoses, though several presented a greater or lesser narrowing of the auditory canal. "There would thus appear to be a tendency on the part of the aboriginal inhabitants of the American continent to possess modifications in the configuration of the external auditory passage."

In the same year (1879) Flower, in his well-known "Catalogue", notes ear exostoses in 20 crania, as follows: of 12 Guanche, exostoses in 1; of 44 Chatham Islanders, in 4; of 11 "flat-heads" of Northwest American coast, in 1; of 3 from Tennessee mounds, in 2; of 147 from Peru, in 9; of 107 Australians, in 1; of 20 Melanesians, in 2. There is no discussion.

An important account of ear exostoses in North American crania is that of Blake (1880). He reexamined for this abnormality the Indian crania in the Peabody Museum of Harvard University and found the growths in 36 of 195 skulls (a large majority with fronto-occipital compression) from the old mounds and stone graves of Tennessee (18.5 percent), and in 5 out of 108 (undeformed) Indian crania of California (4.6 percent). The exostoses "occurred in both canals in 12 out of 36 crania, and of the remainder in the right canal in 9, in the left canal in 15. Of all the exostoses detected, 54 in number (counting the triple exostosis found, as one), 42 occurred on the posterior and 12 on the anterior wall of the canal. Making the division into 'rounded' and 'flattened' to distinguish the two forms principally assumed by these growths, 12 belonged to the former and 42 to the latter class." In discussing the etiology of these formations Blake reaches no definite

conclusion, but points to the probable influence of "hereditary tendency", without intimation as to what he means by this term.

Miss Studley (1881), in a study of 22 adult Indian crania from Coahuila, Mexico (15 male, 7 female), found ear exostoses in 7 of the males, in none of the females.

In 1864, 1875, 1885, 1889, 1892 and again in 1893, attention to ear exostoses, particularly in American crania, is called by Rudolf Virchow. Among 134 mostly deformed ("flat-head") skulls from Ancon, Peru, he found 18 (13.4 percent) with one or more bony tumors in the external auditory canal. Virchow accentuates the fact that these growths start generally from the tympanic-ring portion of the meatus. In discussing their causation he is at first strongly inclined to associate them with arthritis deformans. Later he evidently weakens in this opinion and believes (1893) that they "are plainly products of a pathological nature"; that "like all exostoses, they owe their inception to a pathological irritation restricted to the pars tympanica"; that possibly they may have some connection with chronic arthritis deformans, also with multiple exostoses of the skeleton; that mechanical causes such as suggested by Seligmann may have a favoring effect on their production; that they are "examples of disturbed development, which probably begins in and proceeds from the end parts of the annulus tympanicus"; and that head deformation is without effect on their production.

Politzer (1889) reports a case of an aural exostosis in a skull from Borneo. He gives considerable attention to the subject of ear exostoses in his well-known Textbook and in other writings. He failed to find any instance of the abnormality in over 1,000 crania of Whites.

Hartmann (1893) reports 14 cases of bony ear tumors in a little over 9,000 White patients (German), or about 1.5 percent.

An extensive series of observations on these abnormalities is published by Ostmann (1894). His report extends to 2,633 skulls, on 2,320 of which he made personal observations, the others being taken from various other authors. The specimens were in the main those of the Königsberg, Berlin, Halle, Senkenberg, Darmstadt, and Breslau anatomical collections, and the series comprised skulls of 1,054 Europeans, 516 Egyptians, 491 Asiatics, 267 Negroes, 113 Australians and Pacific Islanders, and 202 American Indians.

In this material bony outgrowths in the auditory meatus were found in but 16 crania, of which 13 (6.4 percent) were American, 2 (1.8 percent) Polynesian (both Hawaiians), and 1 (0.2 percent) Egyptian. No exostoses were found in the Negroes, the Asiatics, or the Europeans.

Of the 13 American skulls with exostoses in the Ostmann report, 12 are from Peru. The total number of Peruvian crania examined is 111, which gives the frequency of 10.8 percent. As to location of the abnormality in the 12 Peruvian skulls, there was some form of bony outgrowth three times on the right side, twice on the left, and seven times bilaterally. In the remaining Indians and the three non-Indian skulls with ear exostoses, the condition was bilateral in all.

Struck by the frequency of the outgrowths in the American Indians and apparently also in the Polynesians, Ostmann collected all other cases relating to these two groups from previous reports, so that the final number of specimens reached 606 Indians (largely Peruvian), with bony ear growths in 78 (11.5 percent); and 283 "Pacific Islanders" with ear exostoses in 10 (3.5 percent). The American skulls included those of Blake and others mentioned in the present references. Ostmann failed to find records of the abnormality in other races.

As to location, Ostmann saw the exostoses always at the edges of the tympanic ring, on its posterior as well as the anterior border. In one case, however, he found two little "buttons" originating within the meatus near the ring; the picture of that specimen shows the tympanic ring to be thick and bulging at its edges.

Ostmann enters into the discussion of exostoses of the ear in relation to skull deformation. Like Blake, he has given close attention to the shape and size of the opening of the auditory canal and believes erroneously "that, on the whole, the form of the lumen of the meatus depends on the form of the skull, and that in general dolichocephalic crania will show a rounder, brachycephalic crania a more oblongly-oval meatus."⁴ Artificial deformation of the skull, he believes, has a decided effect on the form of the meatus, and the cause of the tympanic exostoses is largely connected with the deformations of the skull. It seems very probable to Ostmann that the narrowing of the opening of the meatus consequent upon the skull deformation results in an irritation which so disturbs the development of the tympanic ring that, especially when any other tendency toward the formation of exostoses exists, hypertrophies in the ossifying parts will result, leading to exostoses.⁵ "The frequent occurrence of exostoses of the outer ear

⁴"Wir können demnach sagen, dass die Form des Gehörgangslumens im Grossen und Ganzen abhängig ist von der Schädelform, und dass im Allgemeinen zu dem dolichocephalen Schädel der mehr kreisrunde, zu dem brachycephalen Schädel der mehr länglichovale Gehörgang gehört." (P. 273.)

⁵"In diesen künstlich veränderten oder in der Veränderung begriffenen Raum wächst der knöcherne Gehörgang hinein, und es will mir als sehr wahrscheinlich

in the old Peruvians may be explained through the action of two causes, the peculiar compression of the outer part of the canal in the brachy- and hyper-brachycephalic [i. e., deformed, flat-head] skulls, and especially a given tendency towards excessive bone growth, such as is manifested through multiple exostoses.”^o

The same year (1894) George Dorsey reports, in his paper on the “Crania from the Necropolis of Ancon, Peru”, 4 crania with ear exostoses among 58 skulls of males (near 7 percent), and 2 among 28 undeformed skulls of females (a little over 9 percent); but the report is of a somewhat casual nature and probably does not fully represent conditions in this respect as they existed in the series of skulls Dr. Dorsey examined.

Bezold (1895) reports the frequency of ear exostoses in over 19,000 White (mainly German) patients with ear troubles to have been 0.6 percent.

A brief report on ear exostoses in American crania is made by Ten Kate (1896). In 50 crania from various localities on the coast of Peru he found 4 with ear exostoses; in 110 Calchaqui skulls of north-western Argentina there was none with such a formation. In view of his evidence he is strongly of the opinion that cranial deformation has no connection with the bony tumors.

The same year Von Luschan, in dealing with various defects and deformations in the external auditory meatus, particularly in deformed skulls from Peru and Argentina, touches also on the meatal hyperostoses and exostoses. He gives no new data, but expresses the opinion that these conditions cannot be attributed to head deformation, for on one hand they are absent from many of the most deformed skulls, and on the other they occur also in skulls that have no deformation. The real causes of these bony growths are uncertain; in individual cases they may perhaps originate in consequence of the constant drag produced by heavy ear pendants and great enlargement of the lobule.

erscheinen, dass wir in dieser besonderen, künstlich geschaffenen Raumveränderung und Beschränkung ein Irritamentum zu suchen haben, welches das wachsende Os tympanicum in seiner normalen Entwicklung derartig zu stören vermöchte, dass es, bei einer aus irgend welchen anderen Gründen vorhandenen Disposition zur Exostosenbildung, überhaupt an Stellen welche zur Ossification schritten, excessiv wucherte und somit Exostosen des äusseren Gehörgans erzeugte.” (P. 274.)

^o“Aus dem besonderen Zusammenwirken zweier Momente, der eigenartigen Verdrückung des äusseren Gehörgans bei den brachy- und hyperbrachycephalen Schädeln und einer gegebenen Neigung zu excessivem Knochenwachsthum überhaupt, wie sie durch die Exostosis multiplex zu Tage tritt, würde sich somit das so auffallend häufige Vorkommen von Exostosen des äusseren Gehörgans bei den alten Peruanern erklären lassen.” (P. 275.)

The largest series of American crania examined for tympanic exostoses before the present work is that of Russell (1900). It comprised in all the skulls of 1,369 American aborigines,⁷ which gave the following proportions of exostoses :

Ear Exostoses in American Aborigines

Crania	Exostoses in crania	Per-cent	Crania	Exostoses in crania	Per-cent
51 Eskimo.....	0	0	22 New Mexico (pueblos).....	0	0
64 Indians, New England.....	0	0	158 Indians, Calif....	2	1.2
58 Indians, Florida..	3	5.2	66 Indians, Pueblo and Plains....	2	3.0
456 Ohio and Tennessee (mounds).....	69	15.1	47 Indians, Mexican	4	8.5
			447 Indians, Peru....	24	5.4

Total no. of subjects, 1,369; total no. of skulls with ear exostoses, 104; percent, 7.6.

Russell's comments on the abnormalities are as follows :

There is a tendency in all races toward the formation of bony tumours or exostoses in the external auditory meatus. The tendency is increased in deformed crania, though it is now believed that such exostoses are not a necessary accompaniment of deformation; in support of this it will be noted that the small series of crania from New Mexico with pronounced occipital deformation exhibit not a single case of tympanic exostosis. . . . The exostoses varied in size from minute nodules to large tumorous growths and, in several instances, resulted in complete occlusion of the external auditory meatus.

Ranke (1900) found, among 21 skulls from Ancon, 3 (14 percent) with ear exostoses. He regarded these as examples of an "endemic disease common to the burial grounds of Ancon as well as those of old Peru in general."⁸

Moore (1900) reports that ear exostoses are "common in Hawaii", but gives no data or observations; and Meyer and Jablonowski (1901, p. 75) mention such growths in 2 among 24 crania from Easter Island.

Le Double and Lebourg (1903) report 9 cases of these growths in 46 skulls of American Indians (19.6 percent). Their causation is uncertain: they are evidently neither congenital "as was supposed by Velpeau", nor of pathological origin.

In 1904 Körner states that he found ear exostoses at Rostock in 16 cases among 2,162 patients with ear troubles, or 0.74 percent; along the

⁷ The printed table contains errors which have here been corrected. The material examined includes that reported on by Blake.

⁸ "Eine für das Totenfeld von Ancon, wie für alle altperuanischen Leichenstätten endemische Erkrankungsform."

seacoast of Germany he encountered 111 cases in 2,876 aural patients, or 3.86 percent.

One of the later treatises of anthropological interest on the auditory canal and its exostoses is a dissertation by Bachauer (1909). He made glue casts and measurements of the canal. Among the 33 Peruvian skulls of the München anthropological collection (including doubtless those reported upon by Ranke), he found 4 (12.1 percent) with exostoses. Bachauer takes up various questions in connection with the meatus. He finds that the only relation between the skull and the auditory canal is that in general large skulls have large canals, and small skulls smaller ones. He does not find that the dolichocephalic have a round, and the brachycephalic an oval, meatus, as was claimed by Ostmann. He also reaches the conclusion that race makes no difference in the shape of the lumen of the canal. But there is a decrease of the lumen in some deformed skulls. His wax casts comprised a series of deformed American and undeformed European skulls. He measured the longitudinal and transverse diameters at the orifice and found decreased lumen in 5 among 32 skulls from Pachacamac (15.6 percent). In three deformed skulls from that locality there were slitlike canals. Bachauer's main deduction is that the cause of the tympanic exostoses has not yet been found, but that their formation is no special characteristic of the old Peruvians.

In 1913, in my report on the results of my observations on the skeletal remains in Peru, I gave the following brief note on ear exostoses (Hrdlička, 1914):

A relatively large proportion of the pre-Columbian people of the more central parts of the Peruvian coast suffered, as shown by the skulls, from a greater or lesser occlusion of the external auditory canals by bony tumors. These are generally hard osteomata, from one to three in number, ranging in size from those like a minute drop to those of several millimeters in diameter, mostly rounded or pearl-shape, but occasionally irregular, frequently with enamel-like surface, and situated just within, or perhaps protruding slightly from the orifice of the osseous meatus. These little tumors, which are associated with no signs of any inflammatory nature, develop invariably from the tympanic ring and particularly from its extremities. They were in no case seen to coalesce, and though they may almost close the meatus they were never seen to do this entirely. Similar osteomata occur, though far less frequently, among the Whites; and they are found occasionally in the skull of a North American Indian.

Further attention to aural exostoses, in part from the anthropological standpoint, is given by Burton (1927), who has studied those parts of my Peruvian collections which are housed in the Museum of San Diego. Burton's examination of 26 deformed skulls from Peru showed 5 cases of exostosis in the canal and 1 in the middle

ear; 52 other Peruvian crania of the collection showed 5 with exostoses (in all 12.82 percent). Regrettably, the rest of the data are presented in a form that is difficult to understand, and there appear to be some bad printer's errors. To his interesting discussion as to the causation of these growths we shall return later.

In 1930 two important contributions to the subject of ear exostoses among the American aborigines are made independently by Oetteking in New York and Alexander in Vienna. Oetteking (1930) studied the skulls of the northwest coast of North America, Alexander (1930) mainly those of Channel Islands, California.

Oetteking's material is given in the table on page 11.*

In addition to the above Dr. Oetteking examined 43 skulls of the young, belonging to all the above series (including 10 Chinook), without finding any exostosis.

There is no discussion of the pathogeny of the tumors.

Alexander, on a visit to the United States, examined 550 Indian crania. His data are not given in as organized a way as would be desirable. There is no information as to how many specimens were in the different groups involved, and there was no sexing. The total number of skulls with ear exostoses was 30 (5.5 percent). A large majority of the skulls, and also of those with exostoses, were from California. The author adds an account of 21 (erroneously given as 22, nos. 3 and 15 being duplicates) cases of Austrian Whites with such growths, and goes into a detailed discussion of the whole subject.

In 1930, too, Moodie reports a case of ear exostoses in a California Indian; and in 1931 he mentions and illustrates, although with few details and no discussion, six cases in the Peruvian skulls of my San Diego collection, which doubtless had also been included in Burton's report.

The latest and among the most important contributions to the subject of ear exostoses from the anthropological point of view is that of Möller-Holst (1932). He examined 341 Chile-Bolivian skulls, of which 57 (16.7 percent) showed ear exostoses. Strangely, a larger proportion of these were in the undeformed crania (18 percent) than in the deformed (14.8 percent). In 250 skulls of German Whites there was but 1 case of exostoses. The author deals with the subject comprehensively and with much detail.

* Data in his memoir supplemented by Dr. Oetteking in correspondence and arranged by the present writer.

Exostoses in the Auditory Canals in Indians of the Northwest Coast, Adults

All skulls			Males					Females				
Series	Total number of skulls	Number and percentage of skulls with ear exostoses	Skulls examined	Skulls with ear exostoses	Percentage of skulls with exostoses	Ears with exostoses	Percentage of ears with exostoses	Skulls examined	Skulls with ear exostoses	Percentage of skulls with exostoses	Ears with exostoses	Percentage of ears with exostoses
Undeformed (misc. NW. coast) . . .	112	... (2)	78	34
Cowichan (Vancouver Is.)	117	1.71	88	2	2.27	3	1.74	29
Koskimo (Vancouver Is.)	143	(3) 2.09	104	2	1.92	2	0.96	39	1	2.56	2	2.56
Chinook (Wash., Ore.)	83	(23) 27.71	58	19	32.75	34	20.48	25	4	16.00	7	14.00

SUMMARY

The data presented in the preceding pages together form a considerable mass of material of anthropological interest. To make them more easily graspable, they are abstracted in the following tables.

The statistical data on the White peoples are not as comprehensive or as uniform as might be desired, yet there is something of harmony. Ear exostoses in European and American Whites, taken as a whole, are scarce; among those with ear troubles they are found in from 0.4 to 1.5 percent of the cases, except along the German seacoast, where the percentage is apparently higher. Their racial and local frequencies within the White stem at large cannot as yet be estimated.

Added to the above observations on Whites may be those of 1 case of ear exostoses (among 12 skulls) in the Guanche; 1 in a Nubian; and 1 (among 516 skulls or 0.2 percent) in an old Egyptian.

Very different and more precise are the data on the American Indian. Here there are no reports on the living, all the observations having been made on skulls; and the skulls show many of the smaller ear exostoses that would give little if any trouble during life and hence would not come under the attention of the otologist, were he present, thus affecting the statistics. In other words, it is certain that the experience of an otologist with these tumors among the Indians would have differed considerably from that of the examiner of their crania. Nevertheless, even if only those ear exostoses be considered that must have caused distress, their frequency in general is above that in the white man. The records are as shown in tables on pages 13 and 14.

Condensing these two tables and leaving out duplications, we obtain:

Condensed Data on Ear Exostoses in the American Indian

Group	Skulls	Skulls with ear exostoses	Mean percent
Chinook, Flat-head, NW. Coast.	94	24	25.5
Tennessee (& Ohio).	459	71	15.5
Peru, Bolivia (& Chile).	approx. 1,433	149	10.4
California (chiefly).	816	38	4.7
Misc. N. & S. Amer. Indian.	1,004	54	5.4
New England Indian.	64	0
NW. Coast, misc., undefined.	112	0
Calchaqui.	110	0

Résumé of Data of Anthropological Interest on Ear Exostoses in Whites

Year	Author	People	No. of heads or skulls examined	Heads or skulls with ear exostoses		Individual ears or temporal bones		
				Number	Percent	Examined	With ear exostoses	Percent
1868	Toynbee.....	English.....	1,013	14	1.03	
1874	Blake.....	American.....	1,000 cases with ear disease.....	?	
1878	Politzer.....	Austrian.....	over 1,000 skulls.....	0	
1889	Kessel.....	German.....	?	?	
1893	Hartmann.....	German.....	a little over 9,000 patients.....	14	
1894	Ostmann.....	European.....	1,054 skulls.....	0	
1895	Bezold.....	German.....	19,330 patients with ear troubles.....	116	
1904	Körner.....	German..... (Rostock)	2,162 ear patients.....	16	
1904	Körner.....	German..... (coast)	2,876 ear patients.....	111	
1909	Jackson.....	English.....	3,000 cases with ear disease.....	11	
1928	Martin.....	European.....	(no original data).....	
1932	Möller-Holst.....	German.....	250 skulls.....	1	

Résumé of Data on Ear Exostoses in the American Indian

Year	Author	Group	Skulls examined	Skulls with ear exostoses	Percent	Year	Author	Group	Skulls examined	Skulls with ear exostoses	Percent
1864	Seligmann.....	Peru.....	6	5	1900	Russell.....	New Engl. Indians.....	64	0
1864	Welcker.....	Fox Ind.....	?	1			Fla.....	58	3	5.2
1867-75	Davis.....	Peru.....	?	4			Ohio & Tenn.....	456	69	15.1
1874	Wyman.....	Peru.....	330	8	2.4			Pueblos & Plains.....	88	2	2.3
1878	Carr.....	Tenn.....	67	9	13.4			Calif.....	158	2	1.2
1879	Turner.....	Peru.....	?	1	1900	Ranke.....	Mexico.....	47	4	8.5
		Chinook.....	?	1			Peru.....	447	24	5.4
1879	Flower.....	Flat-head Tenn.....	11 3	1 2	9.1 6.1	1903	Le Double & Lebourg	Peru.....	21	3	14.0
		Peru.....	147	9	6.1	1909	Jackson.....	"Amer. Indians"	46	9	19.6
1880	Blake.....	Tenn.....	195	36	18.5			"N. & S. Amer. Indians".....	450	25	5.5
		Calif.....	108	5	4.6	1909	Bachauer.....	Peru.....	33	4	12.1
1881	Studley.....	Coahuila.....	22	7	31.8	1927	Burton.....	Peru.....	78	10	12.8
1885	Virchow.....	Peru (Ancon).....	134	18	13.4	1930	Oetteking.....	NW Coast undefined.....	112	0
		Peru.....	111	12	10.8			Cowichan.....	117	2	1.7
1894	Ostmann.....	"Amer. Ind.".....	91	1	1.1			Koskimo.....	143	3	2.1
1894	Dorsey.....	Peru.....	86	6	7.0			Chinook.....	83	23	27.7
1896	Ten Kate.....	Peru.....	50	4	8.0	1930	Alexander.....	Amer. Ind.....	550	30	5.5
		Calchaqui.....	110	0			(chiefly Calif.)			
						1932	Möller-Holst.....	Chile, Bolivia..	341	57	16.7

Ear Exostoses in Regions other than Europe and America

Asia			Polynesia			Melanesia			Australia			Africa (Negro)		
Skulls	Skulls with ear exostoses	Percent	Skulls	Skulls with ear exostoses	Percent	Skulls	Skulls with ear exostoses	Percent	Skulls	Skulls with ear exostoses	Percent	Skulls	Skulls with ear exostoses	Percent
?	Nepal 1	...	?	Marquesas Islands 3	...	20	2 Melanesians	10	107	1	0.94	267	0	...
491	"Asiatic" 0	0	?	Loyalty Islands 1	...	?	Fiji 2	...	?	1	...	?	1	...
			12	Tenimber Arch. 1	8.3					0				
			44	Chatham Islands 4	9.1									
			?	Hawaii 5	...									
			?	"common"	...									
Easter Island ^a —24—2—8.3														

^a Polynesian, but with probably some Melanesian admixture.

The maximum incidence of ear exostoses is not in Peru, but apparently among the tribes with fronto-occipital head deformation of the Columbia watershed, and in the Tennessee-Ohio mound and stone-grave region; also apparently in the old population that has left its skeletal remains in the caves of Coahuila, northeastern Mexico.

The data will receive further attention in the discussion of causation. For the present it is sufficient to note the fact that in America itself very marked differences exist, as to tribe and location, in the frequency of the growths under consideration.

There is but a single observation on a series of Eskimo skulls and that is negative—Russell in 54 specimens found no exostosis.

From regions other than Europe and America the data on ear exostoses are as yet very inadequate. There is little or nothing in this respect on the peoples of the densely populated areas of China, India, and Malaysia, of the rest of Asia or of Negro Africa, but there are indications that the abnormalities in question are relatively frequent among the Polynesians. The data are given in the table on page 15.

CLINICAL MATERIAL

In addition to the data tabulated in the preceding pages, there are scattered through medical literature of the last and present centuries reports of perhaps as many as 300 separate clinical cases of ear exostoses in white Europeans and Americans. A large majority of these are reported more or less defectively as to nationality, sex, age, and other details of importance, attention having been centered on the pathology and cure of the condition. Anthropologically, they add but little to the knowledge of the growths beyond showing further that they occur with no great rarity in England, France, Belgium, Germany, Italy, and other European countries, as well as in the United States.

Numerous as these reports are, they would not suffice to give a clear and full picture of the abnormalities. But here and there interesting points appear, and collectively there is much of value on the histology and especially on the etiology of these ear tumors.

The earliest comprehensive account of this nature is that of Joseph Toynbee (1850). He reports 12 cases of such "tumors", 10 (apparently) in males and 2 in females, mostly elderly people of British extraction. The exostoses consist of very hard and dense bone, are of slow growth, and develop frequently "unattended with any symptoms." He strongly suspects their connection with gouty diathesis and from a further standpoint of causation divides them into two classes—one "in which the disease appears associated with congestion

of the mucous membrane of the ear, as a result of rather free living" (and drinking); and the second associated with "disease in the cavities containing the expansion of the auditory nerve."

The first "thesis" devoted entirely to the subject of ear exostoses is by Delstanche (1878); and in the course of time this is followed by other such treatises by Schlomka (1891), Braunberger (1896), Sabroux (1901), and Bachauer (1909); to which may be added the comprehensive dissertations on the subject by Alexander (1930) and Möller-Holst (1932).

It would seem that a relatively limited condition that has received such prolonged and extensive attention should be well understood by this time; but, as will be shown later, this is still far from being true.

The records of over 200 cases of ear exostoses reported by aural surgeons are given in the next table. The stated nationality is usually that of the author, but the subjects, especially in such complexes as Austria or the United States of America doubtless included various other racial elements.

The data as to the sex, side, etc., do not always extend to the whole or an equal number of cases reported, which reduces their value. They need not be considered at this juncture; as far as they go they will be dealt with in subsequent chapters.

The table on page 18 has no pretense to completeness. There are records of additional cases, but some of these are little more than mere mentions, while with others the original report was unobtainable.

Bürkner (1884, pp. 92-93) summarized the statistical data on ear diseases published by 16 authors to 1884, but combined, regrettably, stenoses, exostoses, and atresiae into one group, and there is no way of separating the three. The figures had nevertheless some interest. In all there were 94 cases of the three above-named conditions, reported by 6 authors; and their combined frequency was, for Gruber 0.2; Lucae 0.2; Hedinger 0.3; Newark 0.3; Burkhardt-Merian 0.5; and Schwartze 0.2 percent of all cases with ear diseases.

What stands out from all the preceding data is the wide distribution of the incidence of ear exostoses, geographically, racially, and also in time. It is no recent or local affliction, but an old and widely generalized disorder. A few racial groups appear immune, but from none of these is there sufficient material to decide the question. In the remainder the frequency varies greatly, and this variance seems to follow racial or geographical affinities, but there appear no few exceptions to this, especially in the American Indian, where group conditions evidently prevail over the racial.

NEW OBSERVATIONS

In 1910 and again in 1913 the writer made trips to Peru. Owing to some fortunate circumstances and with the invaluable aid of the Peruvian authorities, he was able to make large skeletal collections which, aside from a mass of other parts of the skeleton, comprised approximately 4,000 skulls (Hrdlička, 1911, 1914). These proceeded mainly from the coasts but in an important degree also from the mountains. A portion of this material was used in 1915 in the preparation of the anthropological exhibit for the Panama-California Exposition and remains in the San Diego Museum; the rest is preserved in the National Museum at Washington.

Even in the field I was struck by the frequent presence in the outer half of the external auditory meatus of bony swellings and in some cases distinct tumors that more or less restricted or even almost closed the ear opening. In the report on the second expedition (Hrdlička, 1914), I briefly called attention to the fact that "a relatively large proportion of the pre-Columbian people of the more central parts of the Peruvian coast suffered from a greater or lesser occlusion of the external auditory canals by bony tumors." A small series of these crania with ear exostoses was exhibited and remained at San Diego, and another series was placed on exhibit in the Division of Physical Anthropology at the United States National Museum for demonstration to visiting surgeons.

In 1921-22, at my instigation, the series of Peruvian skulls in the United States National Museum was examined for the bony tumors in question by Dr. Beatrice Bickel. During these examinations and especially when an attempt was made to prepare the results for publication, it was found that the subject was more complex than at first anticipated and that some needed data were not obtained, which led to a second study of the whole series by Dr. Paul Van Natta, then Aid in the Division of Physical Anthropology of the Museum; and as the results of this second study differed somewhat from those of the first, a larger part of the collection was submitted to a third examination by myself. The results differed slightly from those of both previous examinations, but the differences in the three were seen now to be mostly only those in the precise appraisal of the various grades of the abnormality, the essentials remaining fairly constant.

Subsequently, finding the condition repeatedly also in other Indian and even in some non-American skulls, I extended the personal examination to a number of series of crania in the National Museum collections. Then other work intervened, and the publication of the results had to be postponed.

Meanwhile, as already noted in the first section of this memoir, the material left in San Diego received attention by a number of students from the west coast, two of whom, Burton and Moodie, reported on the ear exostoses of the skulls. Other publications on the growths appeared from time to time. From 1930 to 1932 three especially important studies in this line were published, namely those by Oetteking, Alexander, and Möller-Holst. Moreover, additions were received to our collections which promised to throw additional light on the peculiar disorder. These considerations led me to a determination to finish the survey of the subject, add as much as possible to the previous data, and attempt, should the facts warrant, to advance the understanding of the affliction under consideration. The results follow.

NEW MATERIAL

The total number of skulls examined for ear exostoses in this new study is 7,814. All these, with the exception of about one-third of the Peruvians, were sexed and examined by me personally.

The material is part of that of the Division of Physical Anthropology, United States National Museum, and the only portion of the specimens reported upon previously were those mentioned casually in my own publications. Only the larger series of our collections were made use of, and such as would give as far as possible a widespread racial as well as geographical and time distribution.

The abnormal bone formations were found to range without any line of separation from distinct localized "pearls"¹⁰ or tumefactions of bone in the external auditory canal to bony tumors that almost fill the distal part of the canal or even protrude outside of it. Only those cases were recorded where the growth presented distinct localized welting, excrescence, or tumor. In addition there were fairly numerous cases where a more or less evident trace of a tumefaction or a diffuse pathological thickening of the wall existed; these were not included in the records.

The earlier and again the late stages of ear exostoses present difficulties to the examiner. The initial tumescence, "pearl" or welt, may be ill defined; and one or two small swellings, welts or "pimples" or ridges, may accompany a larger growth which tends to preempt the attention or obstruct clear vision. Hence no two observers or even repeated examinations by the same student will give absolutely

¹⁰ The term "pearl" is particularly fitting, for many of the growths in their earlier stages very closely resemble developing pearls on their mother shell.

the same results as to the minor grades of the abnormalities. Considerable experience must be acquired by the student of these exostoses before his records can have real value.

The total new material and the gross results of the examination are shown in the following table.

Ear Exostoses in Different Racial Groups, New Observations

Adults ^a (except as specified otherwise)	Number of skulls examined	Number of skulls with ear exostoses	Percent of skulls with exostoses	Number of ears with exostoses	Percent of ears with exostoses
Egypt:					
XII D. Lisht.....	379	7	1.85	10	1.3
XX D.—III Cont. Kharga...	75	2	2.7	2	1.3
American:					
Eskimo.....	1,000	2	0.2	4	0.2
Indian Children ^b	335	1	1
Old Pueblo.....	500	12	2.4	19	1.9
North Dakota.....	29	2	6.9	2	3.45
Florida.....	395	35	8.9	53	6.7
California ^c	435	46	10.6	69	7.9
NE. States (St. Lawrence River to Maryland).....	112	13	11.6	19	8.5
Peru.....	3,651	522	14.3	855	11.7
Virginia.....	65	14	21.5	25	19.2
Louisiana ^d	61	15	24.6	26	21.3
Arkansas ^d	173	47	27.2	75	21.7
S. Dakota (All, Mowbridge, Arikara, misc.).....	109	30	27.5	48	22.0
S. Dakota (Mowbridge alone)	76	23	30.3	37	24.3
Kentucky.....	90	29	32.2	52	28.9
Polynesian:					
New Zealand.....	19	4	21.1	7	18.4
Hawaii.....	148	39	26.4	60	20.3
Asiatic:					
Chinese.....	77
Malaysian:					
Pagi-Pagi.....	10
Melanesian.....	39
African:					
Negro (African and American)	112

^a Including a very small proportion of subadults.

^b From age when fully developed tympanic bone is in place to eruption of a permanent second molar. A fair proportion of deformed, all three varieties of deformation.

^c Mainly of Channel Islands.

^d Mounds.

Examination of our Egyptian material, all of which was collected personally and is thoroughly identified, shows that although ear exostoses were rare, nevertheless they occurred in the Egyptians—at root a branch of the White stem—as far back as 2000 B. C.

There is no case of a tympanic exostosis in the 112 African and American Negro crania in our collection. It will be recalled that Ostmann, in 267 Negro skulls, also found no case of these exostoses. It would seem, therefore, that the true Negro was free of these formations.

No case of these tumors is found in our Melanesian and Malaysian skulls, but the series of specimens here are too small. Flower, it was seen, found one case of these exostoses in 1 of 7 Australian and in 1 of 20 Melanesian skulls. It appears, therefore, that the condition is not wholly absent either in Melanesia or Australia, though it probably is rare in these territories.

Especially interesting is the apparently complete absence of ear exostoses in the Chinese. No case in these people, so far as I could discover, is on record, and the valuable series of 77 adult male Cantonese skulls in our collection shows not a trace of bony ear tumors. Yet the Chinese belong fundamentally to the same yellow-brown human stem as do the American Indians, who show so many of these abnormalities, while on the other hand they are far apart from the African Negro, who similarly appears to be free from ear exostoses.

In the remaining groups of our table conditions differ greatly. At one end of the series stand the Eskimo, first cousins of the Indians, who in 1,000 skulls give but 2 with a moderate form of distinct localized tympanic tumefaction; at the other end are the Kentucky, South Dakota, Arkansas, Louisiana, and Virginia Indians, with the Hawaii and New Zealand Polynesians, among whom over one-fifth to one-third of the skulls show the neoplasms under consideration. The Arkansas and Louisiana Indians range themselves territorially with those of Tennessee and also Ohio, in whom both Blake and Russell found a high incidence of these growths; the Kentucky Indians show a slight similarity to those of Tennessee; the Dakotas are unconnected with any earlier or present groups reported on in this connection; our Polynesians harmonize with Welcker's and Davis' Marquesans, who also showed a high incidence of ear exostoses, and seemingly with the Polynesians in general.

From all the preceding it is plain that the highest frequency of the condition is found, on one hand, among the old aborigines of the North American continent, and on the other hand, in Polynesia. In North America ear exostoses were most frequent in portions of the north-central, south-central and central-eastern parts of the present territory of the United States, in the Columbia basin "flat-heads" (Oetteking), in some parts, at least, of Mexico (Studley: Coahuila); and in South America, in Peru. Peru, which was supposed to head all the Ameri-

can groups in the frequency of these growths, is seen to be barely in the middle of the American range of their frequencies.

Additional details of importance regarding the development and prevalence of the abnormalities under consideration on the American continent, and of their significance, will be dealt with in succeeding sections.

DETAILED DATA

AGE

Older observations.—The youngest subject in whom an exostosis in the external auditory canal has so far been observed, recorded by Field (1878a), was a girl of 3 years, in whom the bony growth followed the removal of a polyp. This being by far the earliest age at which the abnormality has been found, the case deserves to be quoted in full; the report reads:

M. W., a little girl aged 3, was brought to the hospital on July 25th. Her mother states that she had suffered from a severe attack of measles 12 months previously, and that she had since had an offensive discharge from the left ear. I had a few months since removed a polypus. About a fortnight ago, she noticed a hard substance in the ear, causing the child much uneasiness. When she came to the hospital, a small pedunculated osseous tumour about the shape of a pear was discovered, almost filling up the meatus.

The individually recorded cases in the young and up to about the age of puberty, that I was able to find in the literature, are as follows:

Field (1878a), in a girl of 3	Brindel (in Sabroux, 1901), in a boy of 13
Alexander (1930), in a boy of 9	Alexander (1930), in a girl of 13
Tod (1909), in a boy of 10	Kessel (1889), in a girl of 14
Krakauer (1891), in a girl of 12	Ferreri (1904), in a girl of 14
Garrigou-Désarènes (1888), in a boy of 12	Bezold (1895), in a boy of 14
Karewski (1892), in a girl of 13	Green (1879), in a boy of 14

It may be worthy of note that of the 12 subjects for whom both the individual ages and sex are given, 6 were males and 6 females, a relation which, as will be seen in the next section, does not hold later in life, when the exostoses are much more numerous in the males.

Bezold (1895, p. 48) mentions an isolated case in a boy of 14; and in addition West (1909) reports a case "in a child of 12", who was probably a girl, for the term "child" would scarcely be applied to a boy of that age.

The great rarity of ear exostoses in children appears most strikingly from the data published by Bezold (1885). Examinations by

aurists for ear troubles in 9,939 school children failed to show even a single case of the tumors. The detailed data were:

Reichard, Riga	1,055 children, no ear exostoses
Weil, Stuttgart	5,905 children, no ear exostoses
Bezold, Munich	1,918 children, no ear exostoses
Sexton, U. S. A.	570 children, no ear exostoses
Norrell, U. S. A.	491 children, no ear exostoses

Kessel (1889) believed that the growths appeared between the ages of 10 and 13, or later—most frequently about the age of puberty. Erhardt thought they originated during the period of the ossification of the canal; and Edward, of Berlin, thought similarly that these exostoses could originate only in the skeletal parts still in the process of formation—opinions opposed by De Rossi, Ferreri, and others.

Braunberger (1896) stated they developed both before and after the ossification period of the external meatus, though they are more common in advancing age. Lake (1898) thought the “hyperostoses often appeared latish in life.”

According to Bezold and Siebenmann (1908, p. 102) “they develop nearly always after puberty.” To which Bezold adds, “In 170 cases which I observed up to 1896 there was none below 15 years. Neither did I find a single case in public schools or deaf-mute institutions.” In another place, however, as noted above, he mentioned a case in a boy of 14.

Gray (1910) states that the bony growths in the ears are “seldom found in children.” Alexander (1930) failed to find these growths in children, even in those whose parents were badly affected by ear exostoses.

In contrast to this Marx (1926), who conceives a substantial distinction between hyperostoses and exostoses, regards as an essential mark of hyperostoses that they occur in early childhood, whereas the exostoses develop in the adult. Von Troeltsch’s (1873) cases “were predominantly in the middle-aged”; and Whitney (1886), in his Indian series, found them “as a rule in men past middle life.”

A most helpful record in this connection is that of Körner (1904, p. 105), who, although going into no details, gives a list by ages “of the hyperostosis and exostosis cases” observed by him in his private practice, “in 1,000 consecutive patients with ear diseases.” The data follow:

"Hyperostoses and Exostoses Cases" Observed by Körner

Age	Subjects	Subjects with exostoses and hyperostoses and percent in total number of growths	
		Number	Percent
0-5.....	81	0 =	0
6-10.....	113	2 =	1.6
11-15.....	116	6 =	4.8
16-20.....	115	11 =	8.8
21-25.....	78	13 =	10.4
26-30.....	77	17 =	13.6
31-35.....	74	12 =	9.6
36-40.....	74	16 =	12.8
41-45.....	68	13 =	10.4
46-50.....	61	7 =	5.6
51-55.....	38	8 =	6.4
56-60.....	45	10 =	8.0
61-65.....	29	4 =	3.2
66-70.....	19	5 =	4.0
Over 70.....	12	1 =	0.8
	1,000	125 =	100.0

To the above I am able to add data which I have culled from additional clinical reports, showing 101 cases where some information as to age was given. Of these, in 25 cases the subjects were merely marked as "adult", or "of mature age", or "elderly". The 77 subjects whose age was stated range as follows:

Age of Patients (White) With Ear Exostoses

Age	Subjects	Percentage of ages
Below 10.....	2	2.6
10-20.....	13	16.9
21-30.....	19	24.7
31-40.....	15	19.5
41-50.....	14	18.2
51-60.....	8	10.4
61-68.....	6	7.8
Above 68.....

The greatest frequencies of the bony growths in the external auditory canal are registered, it is seen, between the ages of 20 and 50. Their period of prevalence extends chiefly from 16 to 60. They are rare below 10 and but one had so far been recorded above 70, though the distribution in our table indicates that a few cases do probably occur above that age.

The condition or "disease", if it can be called such, is therefore, it is clear, dominantly one of the earlier to middle adult life, and has

very little if any connection with senility and its disorders—another point of importance.

It should be borne in mind, moreover, that the clinical age reports embodied in the above data are the ages at the time the subjects applied for treatment, and that in all the cases the bony growths in the ear began earlier. The data therefore show the ages at which the tumors reached development that caused the patient to apply for relief. Should we wish to learn the age at which the ear exostoses began, it would be necessary to shift the whole scale of ages in the direction of less years. How much to shift, on the average, cannot be estimated. In individual cases ear exostoses were known to the patients to have existed for many years before they gave sufficient trouble to lead the subject to the aural surgeon. The matter can only be settled, it would seem, by prolonged future attention to this point.

New observations.—Excluding the Eskimo, the specimens in which both meatus cannot be examined, and the very young, there are in the National Museum 335 skulls of Indian children between the ages when the tympanic portion is fully added to the bony ear and when there occurs the eruption of a permanent M_2 —in other words between about 2 and 12 years of age. The material, like that of the adults, is mainly pre-Columbian, and a good proportion of the skulls show one or another of the three kinds of deformation. A careful scrutiny of these specimens showed 334 without any trace of ear exostoses. The sole specimen showing the abnormality was a pronounced “flat-head” from Santo Domingo, with lateral permanent upper incisors and permanent upper molars about to erupt—hence about 8 to 9 years of age. In the left meatus of this skull is seen on the posterior wall, tympanic part, a small but distinct abnormal nodule, which in all probability would have later grown to a definite exostosis.

It may thus be concluded that, among the old American Indians at least, tympanic exostoses did not develop, or did so but exceedingly rarely, in childhood.

Even in the Indian adolescent of our collections, however, these growths are not very evident. They belong essentially to the earlier half or two-thirds of the adult life, though they not seldom begin before the adult stage is reached. Their maximum frequency and development in the Indian belong principally to the ages of about 30 to 60. They are infrequent in older subjects and, as in Whites, it is plain that they have little if any relation to senility and its pathology. All of these facts are of etiological importance.

SEX

Since Bonnafont (1868), all writers who have dealt with the subject agree that ear exostoses are considerably more common in men than in women. Thus Delstanche (1878, p. 14) says that they are "much more frequent in males," and practically the same words are used by Von Troeltsch (1881, p. 141). Whitney (1886, p. 442) found "the subjects were as a rule men"; for Kessel (1889) the growths were "decidedly more frequent in the males." Schlomka (1891, p. 16) and Sabroux (1901) express themselves exactly as do Delstanche and Von Troeltsch. For Braunberger (1896) it is "certain they are more common in males." There are many other expressions to the same effect.

More definite data on the subject, in living Europeans, are given by Körner and Bezold. The latter says (1908, p. 102): "The male sex is affected much more frequently than the female. My statistics show a proportion of 11 to 1, those of Körner of 3.5 to 1."

The individual clinical reports are frequently negligent as to sex, but from those in which sex is stated, the indications are very conclusive. Out of 89 instances that I was able to gather in which the sex was given, 70 of the individuals, or nearly four-fifths (78.7 percent), were males, and but 19, or a little over one-fifth (21.3 percent), were females. In the old craniological observations on non-European peoples sexing has been attempted in but a very few cases and that inadequately; but as far as the data go they show among those affected with ear exostoses a decided predominance of males.

New observations.—The new materials reported upon in this work have all been sexed on the basis of ample experience, with all possible care, and often with the aid of the rest of the skeleton, so that the records may safely be held reliable to within less than 5 percent of possible error. The results are given in the table on page 28.

The data show that:

In all the groups, Egyptian, American, and Polynesian, ear exostoses are more common in the males than in the females.

The total frequency of the growths in a group appears to have little if any influence on their relative frequency in the two sexes.

The proportion of occurrence in the two sexes differs considerably between some of the groups. Much of this difference is probably connected with the unequal and not always adequate number of specimens, but apparently there are also other reasons, the nature of which remains obscure.

In the two Polynesian groups the relative frequency of the growths in the females is higher than that in any of the American series.

The clinical records cannot be directly compared with our figures; they lack one of the essentials, which is the proportion in each sex of those with ear tumors to those without; but as the proportion of the two sexes in the White population at large is much the same, the relative values of the cases reported are probably nearly correct. They

Relative Frequency of Ear Exostoses in the Two Sexes

Group (in order of frequency of exostoses)	Total number of skulls examined	Total number of skulls with ear exostoses	Percentage of skulls with exostoses in:		Male to female (male = 100)
			Males	Females	
Egyptian.....	454	9	3.1	1.15	37.2
American:					
Eskimo.....	1,000	2	0.8
Old Pueblo.....	500	12	2.8	2.0	71.4
N. Dakota.....	29	2	11.1
Florida.....	395	35	13.7	3.3	24.1
California.....	435	46	15.2	5.7	37.5
NE. States.....	112	13	16.0	10.2	63.8
Peru.....	3,651	522	22.2	6.3	28.4
Virginia.....	65	14	28.6	13.3	46.5
Louisiana.....	61	15	46.4	6.1	13.1
Arkansas.....	173	47	38.6	16.7	43.3
S. Dakota, all.....	109	30	38.2	16.7	43.7
S. Dakota, Mowbridge.....	76	23	41.3	21.4	51.8
Kentucky.....	90	29	48.0	12.5	26.0
Polynesian:					
New Zealand.....	19	4	25.0	18.2	72.8
Hawaii.....	148	39	28.4	24.7	87.0

indicate that for every 100 White males with ear exostoses there are about 27 females with that affection. In most of the Indian groups and in both the Polynesian groups the proportion of females was decidedly higher, a fact for which there must be reasons as yet undetermined.

FREQUENCY OF EXOSTOSES IN THE TWO EARS

Our material permits us to show definitely the number of individual ears affected in the different groups, and the proportional involvement of the two ears in the affected skulls.

The next table gives for our series of groups the proportions of affected ears in relation to that of the affected skulls or individuals. It will be seen that, barring a few exceptions, in groups where the frequency of individuals or skulls with ear exostoses is smaller, the percentage of single ears free of the growths is larger than in those groups in which the proportion of individuals or skulls affected by

these abnormalities is larger. In other words, in general, the individuals or skulls that are more subject to ear exostoses will show not only absolutely but also relatively a larger proportion of ears involved than the groups where the growths are less common. Were some of our smaller series as large as are others, the figures would probably be more regular and even more convincing. The meaning of the phenomenon can only be that there must exist something like an oto-exostotic "inclination", which differs in quantity in different racial, geographical, or other groups; and that the larger the quantity of this x in a group, not only the more individuals, but also the larger percentage of individual ears, will become subject to the growths. The affection acts thus as an entity—perhaps more accurately a "diathesis",¹¹ a conception which will be found further strengthened when we come to consider the numbers, masses, and character of the abnormalities under discussion.

Relative Proportion of Skulls and Ears Affected by Ear Exostoses in the Different Groups

Group (in order of frequency of ear exostoses)	Skulls examined	Percentage of skulls with ear exostoses	Ears examined	Percentage of ears with exostoses	Percentage of ears affected vs. percentage of skulls
Egyptian	454	2.0	908	1.3	66.3
American:					
Eskimo	1,000	0.2	2,000	0.2	(100)
Old Pueblo	500	2.4	1,000	1.9	79.2
N. Dakota	29	6.9	58	3.45	50.0
Florida	395	8.9	790	6.7	75.3
California	435	10.6	870	7.9	74.5
NE. States	112	11.6	224	8.5	73.3
Peru	3,651	14.3	7,302	11.7	81.8
Virginia	65	21.5	130	19.2	89.3
Louisiana	61	24.6	122	21.3	86.6
Arkansas	173	27.2	346	21.7	79.8
S. Dakota, all	109	27.5	218	22.0	80.0
S. Dakota, Mowbridge	76	30.3	152	24.3	80.2
Kentucky	90	32.2	180	28.9	89.8
Polynesian:					
New Zealand	19	21.1	38	18.4	87.2
Hawaii	148	26.4	296	20.3	76.9

SIDE

Since the early history of ear exostoses, it has been known that such growths have a tendency to occur bilaterally, but opinions differed as to the frequency of such an occurrence.

¹¹ In the sense of "a constitutional predisposition or aptitude for some particular development" (Webster's New Int. Dict.).

Delstanche (1878, p. 10), stated that though the exostoses showed a tendency to occur on both sides, in his personal experience unilateral cases were "much more frequent". Schlomka (1891, p. 16) and Braunberger (1896) have also reached the conclusion that they occurred more frequently unilaterally than bilaterally. On the other hand, Von Troeltsch (1881, p. 141) saw them to be "predominantly bilateral"; Sabroux (1901, p. 35) says they were "very frequently bilateral"; and there are other statements of similar import.

Blake (1880) gives the first exact data on the subject. Of 231 old Tennessee and California Indian skulls, 38 had ear exostoses: in 14 (36.8 percent) these were bilateral; in 9 (23.7 percent) in the right ear only; and in 15 (39.5 percent) in the left ear only.

Attempts at statistical estimates in Whites were made by Körner (1894), who found the exostoses in 64 percent of cases bilaterally, in 36 percent unilaterally; and by Bezold (1895, p. 48) who found them in 54.4 percent of cases on both sides and in 45.6 percent on one side only. Bezold observed that occasionally, in cases originally unilateral, in time a development of the abnormality would also take place in the second ear.

As to the side in the unilateral cases, Ferreri (1904) thought the growths were more frequent on the left.

New observations.—The table that follows gives the involvement of the ears as to side in our material.

Side

Groups (in order of frequency of ear exostoses)	Skulls examined	Percentage of skulls with ear exostoses	Percentage of skulls with ear exostoses		
			Bilateral	Right ear only	Left ear only
Egyptian.....	454	2.0	33.3	22.2	44.5
American:			(100)
Eskimo.....	1,000	0.2	58.3	16.7	25.0
Old Pueblo.....	500	2.4	(Number inadequate)		
N. Dakota.....	29	6.9	51.4	28.6	20.0
Florida.....	395	8.9	50.0	23.9	26.1
California.....	435	10.6	46.2	15.4	38.5
NE. States.....	112	11.6	63.6	16.1	20.3
Peru.....	3,651	14.3	78.6	7.2	14.3
Virginia.....	65	21.5	73.3	13.3	13.3
Louisiana.....	61	24.6	63.8	19.2	17.0
Arkansas.....	173	27.2	60.0	20.0	20.0
S. Dakota, all.....	109	27.5	60.9	17.4	21.7
S. Dakota, Mowbridge.....	76	30.3	79.3	13.8	6.9
Kentucky.....	90	32.2			
Polynesian:					
New Zealand.....	19	21.1	75.0	25.0
Hawaii.....	148	26.4	53.8	15.4	30.8

The data on page 30 show the following conditions:

1. In general, in a group the larger the number of individuals affected by ear exostoses, the more commonly both ears are involved.
2. The frequency of bilateral as compared to unilateral involvement varies from 33 to 79 percent in the different series of our material.
3. When but one side is involved, there is a perceptibly greater tendency for the abnormalities to develop in the left ear. In the 14 groups of our crania, in 9 the involvement was more frequent on the left side, in 3 on the right side, and in 2 groups it was equal on the two sides.

The proportions of bilateral involvement in our series agree fairly closely with those of Bezold (54.4 percent) and Körner (64 percent) on European Whites. Through all this the affliction again impresses one as something of a pathological entity.

As it is probable that some proportion, at least, of the individuals whose skulls enter into these series, if they had lived longer, would have developed the condition bilaterally, it may be assumed that the general tendency for the tympanic exostoses is to involve both auditory canals; but they evidently tend to start more frequently on the left side. Why this should be so is not apparent, but it is probably connected with nervous and vascular factors.

The very apparent tendency toward a bilateral involvement should be an important factor in the study of the deeper causes of these formations.

NUMBER

Ear exostoses may be single or multiple. Delstanche (1878) encountered up to three in one ear. Von Troeltsch saw "frequently several in one ear, arising from different parts of the wall." Sabroux (1901, p. 35), from the data he gathered, believed them to be "ordinarily single", though there might be two or even three in one ear. For Kerrison (1913, p. 125) they were "multiple oftener than single."

Blake (1880) and Körner (1894, p. 107) alone give some statistics on the point. In Blake's 39 cases of ear exostoses in Tennessee and California Indians, 54 of the 78 ears showed the growths: in 38 ears (70.4 percent) they were single, in 12 (22.2 percent) double, in 3 (5.6 percent) triple, and in 1 (1.8 percent) multiple. In 41 ears Körner found the exostoses 32 times (78 percent) single, 8 times (19.5 percent) double and once (2.7 percent) triple. The two records are remarkably harmonious.

Aside from Blake's there are no data on this subject in the published reports of a more anthropological nature. Among the clinical records

in the literature I was able to find 84 cases, or rather ears, in which the number of exostoses was given. The results follow:

Number of Exostoses in Individual Ears of White Subjects Recorded in Otolological Literature

Number of records on individual ears	Exostoses		
	Single	Double	Triple or more
84	44	27	13
	52.4%	32.1%	15.5%

It seems plain from the above data, small in number and imperfect as they are, that among the Whites, in over one-half to two-thirds of the ears affected by exostoses in the external meatus which come to the attention of the aural surgeons, there is but one of these growths, and in the remaining number there are two or over.

New observations.—A much more satisfactory record can be presented in connection with the new observations that are given in this work, though on different racial groups:

Number of Exostoses in Individual Ears Affected with Such Growths

Group	Skulls	Skulls with ear exostoses	Percentage of exostoses in individual ears			
			1	2	3	Over 3
Egyptian.....	454	9	83.3	8.3	8.3
American:						
Eskimo.....	1,000	2	(100)
Old Pueblo.....	500	12	100
N. Dakota.....	29	2	(100)
Florida.....	395	35	71.7	24.4	2.0	2.0
California.....	435	46	73.7	17.5	7.5	1.2
NE. States.....	112	13	73.7	26.3
Peru.....	3,651	522	46.3	38.6	14.6	0.4
Virginia.....	65	14	52.0	36.0	4.0	8.0
Louisiana.....	61	15	73.2	26.8
Arkansas.....	173	47	73.3	25.3	1.4
S. Dakota, all.....	109	30	75.0	16.7	8.3
S. Dakota, Mowbridge	76	23	81.1	16.2	2.7
Kentucky.....	90	29	57.7	26.9	15.4
Polynesian:						
New Zealand.....	19	4	(42.9)	(14.3)	(14.3)	(28.5)
Hawaii.....	148	39	56.9	36.7	4.9	1.5

It will be seen that in all the larger groups a single outgrowth in a meatus is the most frequent condition. In our Pueblos, curiously, it is the universal, and in our old Egyptians a nearly universal, condition. But in most of the other groups two exostoses per meatus are also fairly frequent; three are scarce, and more than three are decided rarities.

The single tumefaction-exostosis is, as a rule, the initial stage, but a second enlargement, generally from the opposite side of the tympanic portion, will soon follow, the third and perhaps additional growths developing later.

In no less than 6 of the 12 Indian series the percentage of single tumors is practically identical.

In three of the remaining groups, Peru, Virginia, and Kentucky, and in both Polynesian groups, the proportion of cases with two or more growths is exceptionally high.

The Peru and the Kentucky material especially shows many ears with three exostoses.

Two notes of caution are here necessary: 1, In some specimens with one ear exostosis, had the subject survived to older age there might have taken place a development of additional growths; and 2, where the canal is nearly filled by one, two, or three exostoses, other growths, smaller and more posterior, cannot be seen and thus escape enumeration. This means that the proportions of cases with more than one exostosis would be somewhat higher were we dealing with those who lived their full span of life; and that the proportions of two and especially those of three or more growths are in reality in some measure higher than those given in the records; but the excesses in either case could hardly be very material.

The chief meaning the above results convey is once more that the ear affection under consideration appears in the form of an entity or "diathesis", which manifests itself practically identically in a large proportion of different geographic or tribal groups of the same race, but which may also, through some peculiar causes, differ substantially in other groups of the same people.

LOCATION

As in other respects, so in this also there are in the history of ear exostoses some variants of experience and hence of opinion.

According to Toynebee (1860), ear exostoses may develop in any part of the length of the tube; but the part from which they most commonly originate is about the middle third of the passage. . . . Occasionally the posterior wall affords the point of origin to the tumour, and then it not unfrequently resembles a simple bulging of the wall. In other cases, a similar tumour is also developed from the anterior part, and the two protuberances meet and lie in contact in the middle, leaving an inferior and superior triangular space at the place of the original opening of the tube. . . . The tumour may grow from the upper surface of the tube. . . . Two or more tumours, again, extend sometimes from various parts of the circumference of the meatus, and converging towards the center, fill up nearly the whole cavity.

Delstanche (1878) says that the growths may develop from any point of the meatus, but arise most frequently posteriorly. For Blake (1880), most of them are on the posterior wall; for Ayres (1881), they are in any portion of the canal but most frequent posteriorly; Von Troeltsch (1881, p. 141) states they "occur as well at the beginning of the bony canal as close to the drum . . . by far the most often from the posterior and superior, less often from the anterior wall."

R. Virchow, and after him Hartmann, Ostmann, Körner, and Marx, held that the abnormal bony growths in the external auditory canal originated generally (or even invariably) from the borders of the tympanic bone, where they lay on and fused with the squamous portion of the temporal; some of these authors, however, had observed also occasional exostoses in other parts of the canal. Moos (cited by Goldstein, 1898), in his cases, observed that they arise "invariably from the upper wall of the canal, almost at its outer end"; in Jacquemart's (1889) practice they were "encountered most commonly at the inferior part of the meatus."

Among additional statements, some of which merely repeat others, the following may be quoted. Schlomka (1891, p. 16): "As to their origin, these exostoses arise most often from the postero-superior wall of the auditory canal . . . more seldom from the anterior, most rarely from the lower portion of the same." Sabroux (1901, p. 34) says that they develop anteriorly and posteriorly as well as superiorly and inferiorly, "but it is at the union of the cartilaginous with the bony part (of the meatus), or again quite close to the drum, that we observe them most often." Ferreri (1904): "Most frequent posteriorly and superiorly." Kessel (1889, p. 285): "As far as the place of origin is concerned, the globular exostoses arise from the posterior and superior wall, the cylindrical ones extend along the floor of the meatus parallel to its axis, while the osteophytes occur preferably on the superior part of the inner portion of the canal." Kerrison (1913, p. 125): "Oftenest on the anterior and posterior walls. . . . When one growth only is present, the anterior wall near the attachment of the drum membrane, is the most common site." Dahlström (1923, p. 213): "Most of the exostoses were found approximately on the boundary between the cartilaginous and the bony parts." Burton (1927): "By far the larger number of aural exostoses are found along the suture lines between the canal and the rest of the temporal bone." Oetteking (1930, p. 249): "The pea-shaped restricted to marginal area of meatus; more or less pedunculated anterior or posterior; the crest-shaped is elongated and extends from without inward."

For Möller-Holst (1932, p. 96), who had the advantage of observing numerous cases in skulls, "the exostoses of the auditory canal occur in the outer, middle, and inner portions of the canal. They are located on the tympanic bone in different places, mostly on the boundary of this bone and the squama or pars mastoidea. They seldom proceed from the squama." In his material, "they occurred with about equal frequency anteriorly and posteriorly in the tympanic part; one-third of the cases showed them anteriorly, one-third posteriorly, and the last third both anteriorly and posteriorly."

Older records.—The only actual record on the location of ear exostoses within the meatus is that of Blake (1880). In 45 Indian skulls with such growths, from Tennessee, California, and Arkansas, out of a total of 82 exostoses 55 (66.3 percent) were posterior, 24 (28.9 percent) anterior, 3 (3.6 percent) antero-superior, and 1 (1.2 percent) postero-inferior.

New observations.—The location of the exostoses was noted in all of our material. It was as shown in the table on page 36.

Notwithstanding some significant differences, there is a remarkable basic agreement in the figures, and also between that part of them that embraces the bulk of the American Indian material and those of Blake on the same race.

It may now definitely be said that ear exostoses in the American Indian (with a few exceptions), regardless of the amount of total involvement by the growths, will be in something over 60 percent (of all the exostoses) posterior, in from 20 to 40 percent anterior to antero-superior, and in a small percentage—and that in but some of the groups—postero-inferior or antero-inferior. Superior (squamous part) outgrowths occurred in but three of the series, inferior outgrowths in but one and that only in a single instance.

Some observers would perhaps be inclined to class some of the cases included in "posterior" as postero-inferior or postero-superior, but that would not alter the main significance of the above showing. This is that, in general, in the American Indian, approximately two-thirds of the ear exostoses arose from the posterior end or portion of what was originally the tympanic ring and later developed into the tympanic bone; that nearly one-third of the growths arose from the anterior end of the ring and subsequent bone; and that in but a few groups was there apparently any tendency toward a development of bony excrescences from the squamous portion of the meatus—though the incidence and proportions as given in the table for this item would probably be augmented somewhat if an examination of the whole squamous part were always possible; and that the floor of the meatus

Place of Origin of the Ear Exostoses within the Meatus

Group	Number of skulls examined	Number of skulls with exostoses	Location of exostoses, in percentage of total number of the growths									
			Posterior	Postero-superior	Postero-inferior	Anterior	Antero-superior	Antero-inferior	Superior	Inferior		
Egyptian.....	454	9	82.4	17.6
American:												
Eskimo.....	1,000	2	100
Old Pueblo.....	500	12	100
N. Dakota.....	29	2	(100)
Florida.....	395	35	64.3	2.9	1.4	7.1	24.3
California.....	435	46	66.0	...	1.1	7.4	25.5
NE. States.....	112	13	62.5	37.5
Peru.....	3,651	522	42.7	...	1.0	30.9	25.3	0.1
Virginia.....	65	14	57.1	23.8	14.3	4.8
Louisiana.....	61	15	71.9	...	6.3	...	21.9
Arkansas.....	173	47	65.6	...	2.1	15.6	14.6	2.1
S. Dakota, all.....	109	30	61.7	...	1.5	17.6	5.9	8.8	2.9	...	1.5	...
S. Dakota, Mowbridge.....	76	23	74.5	14.9	6.4	4.3	...
Kentucky.....	90	29	62.2	15.9	20.7	1.2	...
Polynesian:												
New Zealand.....	19	4	53.3	20.0	26.7
Hawaii.....	148	39	52.4	19.0	23.8

is practically never primarily involved by these abnormalities, though it may be secondarily involved when the posterior or anterior exostoses are large and diffuse.

In the old Egyptians of 4,000 years ago there is the same predominance of posterior growths, with a smaller proportion of anterior, and no other.

In the Polynesians conditions differ but slightly from those in the Americans: there are somewhat less of posterior and correspondingly more of anterior and antero-superior exostoses.

The data demonstrate once more that, although there are some group differences in the location of ear exostoses, this location discloses certain general tendencies, which in their turn support the conception of the process of these growths as a definite and separate abnormal entity.

Observation along this line on large numbers of specimens leaves a strong impression of basic definiteness and rule, both as to location and mode of development, which is radically opposed to any incidental or purely local origin of these formations.

SIZE

In size the ear exostoses vary, according to Wyman (1874) from "a pin's head to that of the whole caliber of the canal"; according to Whitney (1886), "from a simple thickening all stages can be traced, up to the formation of round osseous growths as large as peas, which in one or two cases have completely blocked up the opening"; according to Russell (1900), from "minute nodule to large tumorous growths". Sabroux (1901) says that their volume varies much—from a simple protrusion on the walls of the canal to a complete obliteration of the same. For Gray (1910) their size ranges from "a pinhead to that of a bean". Dahlström (1923) states that they "seldom reach such a size that they would completely close the meatus." Möller-Holst (1932) says that "the size varies from that of a pinhead to exostoses that involve nearly one whole wall of the meatus; while in height they range from very low to those that project up to 7 mm." There are additional statements on the point, but they merely repeat more or less what has been given here.

New observations.—From our observations, unimpeded by any soft parts or wax or discharges, it is possible to state as follows: The growths differ from small distinct abnormal bulgings or little circumscribed exostoses to bony tumors that almost occlude the meatus, or even protrude beyond it. In no instance has an absolute occlusion of the auditory canal been seen, but when in life the parts were covered

with skin the closure in some of the cases must have been about complete. Large growths are frequently accompanied by smaller ones. The circumscribed exostoses never coalesce, and they never become fused with the wall they reach in their growth.

An attempt was made to record the exostoses found as to size. Such a procedure is difficult and calls not only for extensive experience but also for a clear notion as to the range of variation of the growths. With these conditions satisfied, it is possible to arrive at a rational classification which, although incapable of mathematical accuracy, is nevertheless really useful for conveying a fair picture of the conditions.

The whole range in size of the growths was divided into small, moderate to medium, and large. The "small" ranged from that which could be distinctly diagnosed as a new growth to those grades where the formation began to be too much developed to be still readily included in that class; the "moderate to medium" were those from the upper boundary of the "small" to such as would occlude up to a half of the canal; and the "large" were those growths that occluded more than half of the meatus. The results obtained are not without interest:

Size of the Ear Exostoses

Group	Number of skulls examined	Percentage of skulls with ear exostoses	Size of the bony growths		
			Small	Moderate to medium	Large
Egyptian.....	454	2.0	Percent 76.5	Percent 23.5	Percent ...
American:					
Eskimo.....	1,000	0.2	25.0	75.0	...
Old Pueblo.....	500	2.4	100.0
N. Dakota.....	29	6.0	50.0	50.0	...
Florida.....	395	8.0	67.2	25.7	7.1
California.....	435	10.6	78.8	18.1	3.2
NE. States.....	112	11.6	75.0	25.0	...
Peru.....	3,651	14.3	50.9	42.5	6.6
Virginia.....	65	21.5	52.4	40.5	7.1
Louisiana.....	61	24.6	78.1	18.7	3.1
Arkansas.....	173	27.2	65.7	28.1	6.2
S. Dakota, all.....	109	27.5	60.3	39.7	...
S. Dakota, Mowbridge.....	76	30.3	55.1	44.9	...
Kentucky.....	90	32.2	45.1	50.0	4.9
Polynesian:					
New Zealand.....	19	21.1	86.7	13.3	...
Hawaii.....	148	26.4	96.7	3.3	...

There are some very perceptible and significant differences in the above figures. In the old Egyptians, the Pueblos, and the two Poly-

nesian groups, in the two Dakotas and in the northeastern American States, there were no exostoses that could be recorded as "large". In the Egyptians, the Pueblos, and the Hawaiians, in particular, notwithstanding their widely differing total involvement by the growths, the exostoses were all or almost all small. The greatest collective "massiness" of the abnormal formations occurred in Kentucky, Virginia, Arkansas, Florida, and Peru—again under widely differing total involvement.

The causes of the above differences are not clear. If it were practicable to divide the basic causes of these exostoses into hereditary and those checking, or again favoring or exciting, their development and growth in the predisposed individual—as may be correct—then it could be conceived that the differences in their total bulk in a group were due proportionately to the checking or favoring factors. Another influence that enters into the subject is that of age. The growths need time for their development to a large size. Of two groups equally subject to the exostoses the younger would presumably show less mass of the growths. It is probable that the mean age of the affected skulls is not the same in all the groups. But age alone could not possibly account for all the differences encountered.

One item is clear from the results shown in the preceding table, and that is that the numerical involvement by ear exostoses in different groups does not always go hand in hand with the collective massiness of the growths.

SHAPES

Ear exostoses occur in many shapes, and these merge with each other so much that any definite classification appears impossible. Blake (1880) believed that he could recognize two main forms, the "rounded" and the "flattened". Von Troeltsch (1881) divided the better differentiated ones into broad-based and pedunculated. Kessel (1889, p. 285) states they are "multiform", but fall into three classes, namely, hyperostoses, periostoses, and exostoses; under the latter "are understood more or less circumscribed tumors that grow especially in one direction and stand either vertically to or parallel with the axis of the canal. One can observe rounded, cylindrical, and conical exostoses"—but there are also transitional and peculiar forms; there are, too, spinelike growths which have been called "osteophytes". For Schlomka (1891, p. 16), who doubtless in part follows Kessel, "one can speak of rounded, cylindrical, or conical exostoses; but there are many combinations of these forms", and some of the growths may assume the form of ossified polyps. Sabroux (1901,

p. 35) says that their implantation is various, ranging from large diffuse to one or even more than one "pedicules". Körner (1904, p. 106) believed that "the globular growths tended to be located more outwardly than the small buttonlike exostoses, to arise from the postero-superior wall of the canal, to be larger than the other excrescences—pea to cherry size—and to lead readily to the complete closure of the meatus." Möller-Holst (1932, p. 96) says: "As to the shape, one can distinguish flat, broadly based, semiglobular, globular, and pedunculated exostoses. All the forms connect through intermediary grades."

New observations.—In our examinations it was found that the ear exostoses show a variety of forms which merge into each other, present no distinct separate classes, and can only be subdivided roughly or arbitrarily. They range on one hand from what can clearly be recognized as an abnormal localized tumefaction or bulge on the posterior or anterior tympanic wall to large irregular massy growths with adventitious smaller elevations; from slight oblong ridges directed along the axis of the canal to redundant more or less conflating welts; from a recognizable swelling of the postero-superior or antero-superior terminal part of the tympanic ring or bone, to masses that almost occlude the auditory canal; and from little pearllike exostoses to more or less buttonlike or pedunculated and irregular tumors, some of which nearly occlude and some even protrude from the meatus. On the other hand, there were observed no slender spines, or sharp osteophytic growths, and no forms that could properly be called "cylindrical".

SYMMETRY

There are repeated statements in the literature on ear exostoses that these growths in some cases occur symmetrically in the two ears of the same individual. Thus Dalby (1876) states that "not infrequently both meatus are affected similarly, not only in respect to the presence of these tumors, but also as to their size and number"; and they may also "increase synchronously" in the two canals. For Delstanche (1878, p. 10) "most often, in case the tumors are bilateral, their point of insertion corresponds exactly in the two canals, and they possess also a certain analogy of form and even of size." Ayres (1881) says, "There is seemingly a good deal of uniformity in their development"; and similarly Kessel (1889, p. 286) states, "as to the bilateral cases, it may be remarked that they occasionally appear in the same form and in the same locations and therefore symmetrically"; and for Schlomka (1891, p. 16) the bilateral outgrowths "are occasionally

entirely symmetric, both as to form and location." Noquet (1899) in one case saw perfect symmetry on the two sides—the same aspect, volume, point of origin; Urbantschitsch had one case with two exostoses in each meatus, exactly alike. Sabroux alone (1901, p. 35) considers them as "very rarely implanted symmetrically in the two auditory canals." For Körner (1904, p. 107) they "develop mostly symmetrically"; and also for Möller-Holst (1932, p. 96), "they in part develop very symmetrically."

New observations.—No statistical data have been attempted in this connection, for it was learned that a tendency toward symmetry, where both external auditory canals are affected by exostoses, is the general rule. The likeness extends most to the location of the growths, less to their number and size, and least to the details of their shape. Even where the growths must be recorded as unilateral, there is frequently a trace of a commencing tumefaction in the corresponding locality of the other meatus.

This general tendency of the growths toward symmetry on the two sides connects them clearly, in the view of the writer, with the central neuro-vascular system and is another element of importance in the etiology of these formations.

RATE OF GROWTH

An inquiry into this subject is possible only to the clinician. There are a number of notes on the subject in otological literature.

Toynbee (1860) learned that the development of these tumors may frequently be very gradual and "unattended by any symptoms calculated to attract the attention of the patient." Dalby (1876) found that ear exostoses "may remain without perceptible change for many years."

In the observation of Von Troeltsch (1881), their growth was generally very slow; Braunberger (1896) stated that it was "slow and painless." Kessel (1889, p. 288) noted that, although usually slow, their growth at times was rather rapid. "It was most accelerated toward the time of puberty; older age retards growth. The growth is sometimes uneven; it can cease for a time and then recommence." In Stewart's (1901) experience, although such an occurrence was "extremely rare", yet on occasion these exostoses could take on a rapid growth suddenly.

A summary of all the clinical observations on the rate of growth of ear exostoses is that their early stages are slow, symptomless, and usually ignored even by the subject; that many apparently stop all growth after reaching a smaller or larger size; but that under exciting

conditions, evident or not, there may set in a relatively rapid enlargement, which soon is attended by distressing symptoms that bring the subject to the aural surgeon.

An interesting further fact is that after an operation and removal of an ear exostosis, in a majority of cases the subject remains free from the growth, but in some cases there is a recurrence of the bony tumor. In the absence of both infection and malignancy the latter event implies, it would seem, a special neuro-vascular influence.

SUBDIVISION

Since Toynbee (1860), repeated but not very successful efforts have been made at a classification of ear exostoses, either on the basis of causation, of the form of the tumors, or of their structure.

The morphological classification alone needs to be dealt with in this section. It begins with Cassells (1877), who divides the growths into two categories, namely, the hyperostoses and the exostoses, which he believes to be separate abnormalities and of totally different origin. This clinically convenient subdivision, notwithstanding voices to the contrary and its demonstrable basic inaccuracy, has become generalized in otology and will probably stay there. Von Troeltsch (1881, p. 144) states that hyperostoses are not clearly separable from exostoses, yet he uses the two terms, applying the first to "a generalized hyperplasia of the walls" of the meatus. Virchow, though in general admitting the subdivision, appears at times uncertain; he speaks (1889) of a "hyperostosis" in a Tanimbar skull which closely resembles the "exostoses" of the Peruvians.

Kessel (1889) follows Cassells, but adds two more forms and gives the following somewhat arbitrary definitions: Hyperostoses, involving the whole extent of the canal; exostoses, more or less circumscribed growths; periostoses, ringlike bony growths; and osteophytes, spinous growths.

Pritchard (1891) attempts to divide ear exostoses into: 1, multiple, uniformly smooth and rounded; 2, multiple, irregular in shape; and 3, single, polypoid.

Hartmann (1896, p. 44) has this to say:

Now as it happens that of late years both hyperostoses and exostoses have been described indifferently under the title of exostoses, although they are plainly two different processes; the descriptions of cases vary a great deal, depending on whether the author has had his mind more intent on exostosis or on hyperostosis. That there is an essential difference between the two, is also supported by Virchow, who, with his enormous experience with exostoses, remarked, during the discussion of a paper which I had read in the Berlin Medical Society: "I agree with the reader, particularly in one point which made

itself plain to me many years ago during my ethnological investigations of skulls from the northern portions of the Pacific coasts. I refer to the more diffuse hyperostosis which he has exhibited in his first case. That, I should not call an exostosis at all. Diffuse hyperostosis is quite different from a genuine exostosis. Inasmuch as exostoses have a very typical situation, this interpretation is very plain."

Hyperostosis of the external auditory meatus always limits itself to the pars tympanica, whilst the adjacent squamous portion of the bone has no bony protuberance. . . . The entire pars tympanica may become hyperostotic.

For Lake (1898) hyperostosis is distinct from exostosis, being "a more or less uniform bony stricture of the external meatus." Sabroux (1901, p. 13) distinguishes between exostoses and osteomata, believing the two to differ anatomo-pathologically; but gives no satisfactory rule for differentiating the two.

Körner (1904, pp. 106-7) thus imperfectly distinguishes the two forms:

Of the exostoses, the button- to semiglobular forms are found near the antero-superior border of the drum, in the vicinity of the location, still open at birth, of the original tympanic ring. They remain mostly very small. . . . The hyperostoses are found as a rule in the outer part of the bony meatus. In accord with the differing participation of the tympanic bone in the formation of the lower portions of the bony meatus, they reach up to the middle, seldom to the upper third of the lumen of the canal. They develop usually synchronously on the anterior and the posterior wall, seldom also on the floor of the meatus, in such a manner that the remaining opening of the canal becomes pear-shaped. . . . After what was said it seems that the frequently mentioned occurrence of multiple exostoses in one ear is really to be assumed as a combination of ex- and hyperostoses; only the small exostoses at the upper border of the drum do occasionally occur in a multiple number. . . .

Bezold and Siebenmann (1908, p. 102) offer a somewhat peculiar concept of the hyperostoses and exostoses and decide against speaking of them separately:

We call *exostoses* small round bony growths which are usually found as little white circumscribed elevations in groups of two or more on both sutures of the deepest part of the os tympanicum to the horizontal part of the scale of the temporal bone. One protuberance is usually directly in front, another close behind the short process of the hammer in the drum membrane. A third one often protrudes between the two. *Hyperostoses* present themselves more in the form of diffuse bulgings of the anterior lower, and sometimes also posterior lower wall. A crosscut through the meatus has consequently the shape of a pear with the point downward. We shall speak about exostoses and hyperostoses together, as they are found not infrequently in the same ear.

Jackson (1909) divides the neoplasms merely into: 1, those that entirely block the meatus; 2, those that do so partially; and 3, those that scarcely affect it, causing merely some narrowing.

Ballenger (1914, p. 661) attempts, though hardly successfully, to give precise definitions: "An *exostosis* is a bony tumor growing from the wall of the meatus, and may be either sessile or pedunculated. *Hyperostosis* is a diffuse thickening of the bony tissue, or a true hyperplasia."

Ferreri (1904) opposes the division into hyperostoses and exostoses as artificial. But Gray (1910, p. 137) accepts Cassell's classification, defining ear exostoses as growths "which are circumscribed and even occasionally pedunculated; and hyperostoses, in which a general diffuse thickening of the bony walls takes place."

Manasse (cited by Möller-Holst, 1917, p. 71) says that the hyperostoses are broadly based thickenings, the exostoses showing a globular development; and the same definitions are given by Bauer and Stein (1926). For McKenzie (1920, p. 457) "osteomata in the meatus may be sessile (hyperostosis) or pedunculated (exostosis)."

Bauer, Stein, Kaufmann (cited by Alexander) designate the circumscribed protruding bony growths as exostoses, the more diffuse ones as hyperostoses. "Thereby", says Alexander, "the principal distinction between exostosis and hyperostosis falls; the difference lies simply in the development. The separation of exostoses and hyperostoses of the external auditory canal is not easily possible when they occur at the same time in the same ear passage." Alexander then classifies the growths according to location, into:

1. Exostoses that proceed from the outer border of the os tympanicum.
2. Exostoses that proceed from the inner border of the os tympanicum.
3. Exostoses that arise from the body of the os tympanicum.
4. The flat but slightly protruding exostoses of the inner part of the canal, coming mostly from the terminal line of the os tympanicum.

He also classifies the growths pathognomically, of which more later.

Oetteking (1930) separates hyperostoses and exostoses, but says that "there may be transitional forms", though in shape rather than structure.

Finally Möller-Holst (1932, p. 73, 101, 102) expresses himself thus:

Under hyperostoses Kessel and Ostmann understand general thickenings of the tympanic bone; Kaufmann diffuse bone increase in mass, but also circumscribed growths; Hartmann and Virchow flat exostoses; Manasse broadly based thickenings; Marx diffuse malformations which are to be counted among the hyperplasias and which originate already in childhood; Alexander a structural variation, not an abnormality (*Missbildung*), which when more strongly developed are to be counted with the tumors. Zuckerkandl's exostoses also, are designated by Alexander as hyperostoses. Under exostoses are generally understood localized bony outgrowths.

For Kaufmann, Möller-Holst says, exostoses and hyperostoses are but form-differences. "Marx, too, knows no boundaries between circumscribed exostoses and diffuse hyperostoses, and no more does Alexander, who uses the two terms for the same growths." Möller-Holst's own view is that, though there exist all kinds of transitions between the bony growths in the ears in their form as well as their structure, yet from the clinical point of view there is a justification for subdivisions of the formations on the basis of location, shape, and size. "Speaking generally, therefore, a so-called bony polyp of the meatus may anatomico-pathologically be an exostosis or a hyperostosis"—which last statement is not very clear.

New observations.—It is plain from the above that a generally valid classification of the abnormal bony ear growths has not been realized and in fact, appears to be unrealizable; but that clinically there is a prevalent sense of two or rather three forms—the diffuse or broad-based irregular tumefactions; the circumscribed, occasionally pedunculated tumors, capable of a rapid growth and, together with their soft coverings, of causing an occlusion of the whole canal; and small indolent rarely troublesome "ceiling" growths in the meatus.

The extensive examinations reported in this monograph lead to the conclusion that, aside from the small, more or less pearlike exostoses—or probably better osteomata—arising from the superior or squamous part of the meatus, there is no line of demarcation that would permit any valid subdivision of the growths into hyperostoses and exostoses, or in any other manner. There are many cases where a clear characterization of the growth by one or the other of the above main terms, hyperostosis and exostosis, is impracticable—it is more or less both. There are other more differentiated cases in which at the base the growth would deserve the name of diffuse hyperostosis, but above this is definitely a more or less rounded exostosis. There are cases where what is evidently the same growth, in the same location, will in one of the ears of the same skull show the form of a pronounced exostosis, in the other that of some grade of hyperostosis or an intermediary condition. And there are no few instances in which both or all three of these forms (hyperostoses, exostosis, and intermediary) may be seen in the same ear. The more or less diffuse hyperostosis of the posterior or anterior wall of the meatus is in many cases in all probability but an earlier stage of an exostosis.

Thus otology, for its practical purposes, will doubtless keep its conventional classification of the bony growths of the external auditory canal into hyperostoses, exostoses, and osteomata of the roof; but those who use this classification should be aware of the fact that,

except perhaps for the rare osteomata of the roof, it is merely a conventional and convenient subdivision, without substantial anatomical or pathological foundation.

STRUCTURE

A number of authors who dealt with ear exostoses report the results of a histological examination of these growths. The results show differences; some are more or less cancellous and some are compact tumors, but between the two there is no line of demarcation—they connect by intermediary grades. Thus histology, too, fails to afford any definite basis for the differentiation of these neoplasms into distinct categories. About all that can legitimately be said is that the small, pearlike and the smooth, rounded exostoses are generally the more compact, the tumefactions and the large masses prevalently the more cancellous.

The structure of ear exostoses received attention from the very first report of these cases, that of Autenrieth (1809). The growth was "formed of areolar bone tissue."

Contrary to this, in Toynebee's experience the tumors were compact. In his Textbook (1860) we read:

As far as my opportunities have permitted examination, these tumours . . . appear to consist of extremely hard and dense bone. In one case, where a portion of the bone was denuded of membrane, it appeared shiny, white and polished, like ivory. In another, where, under the misapprehension of the body being a polyp, caustic had been applied, the bone was exposed and found to be extremely hard and devoid of sensibility. In a third instance, where I observed the membrane to be absent, there was a thin layer of cartilage on the surface, beneath which the bone was very hard.

Delstanche (1878) distinguishes "cellular" and "eburnated" structure of ear exostoses. He says (p. 8): "Thus some—the cellular exostoses—are formed by areolar bony tissue which is enveloped by a thin layer of compact bone; others—the eburnated exostoses—are completely formed by compact tissue of much density." Schwartz (q. by Delstanche) "is of the opinion that the spongy and compact states of the exostoses represent merely different phases of the development of the neoplasms, and that exostoses that were at first cancellous can pass into the state of eburnation; and he believes also in the possibility of their transformation in the reverse sense. This opinion is also partaken of by Virchow and Nélaton."

Individual cases were studied histologically by Hedinger, Cocks, Kuhn, Eulenstein, and others. The reports are sometimes rather involved, but all agree on one hand in the complete absence of anything

that would suggest malignity, and on the other in the lack of a substantial basis for any definite subdivision of the growths into different classes.

A case of a pedunculated exostosis operated upon and studied by Politzer (1902, p. 210), "showed here and there very compact lamellae (eburnation) with spaces that contained but few vessels."

Another pedunculated exostosis was removed and studied by Tod (1909, p. 77) who reports briefly as follows: "On making a section the ossification was seen to be proceeding from the centre." Other exostoses "were very hard, with a very thin layer of skin over them."

A number of detailed histological examinations of ear exostoses are reported by Dahlström (1923, pp. 215-216), and notes on the subject may be found in Kessel, Schlomka, Ferreri, Gray, Oetteking, and other authors, but there is nothing to afford any definite aid in the attempt at a classification of these growths.

Marx (1926, p. 502) thus summarizes the results of the histological studies of ear exostoses up to his time:

They consist of compact bone without distinct medullary spaces, but often with strikingly marked vascular canals. In substance the "exostosis eburnea" and the "exostosis spongiosa" are not different, but it is to be accepted that one form passes into the other (Weber, Virchow, Schwartze), and that occasionally also mixed forms are encountered.

Finally, Möller-Holst (1932, pp. 69, 100) states:

Some exostoses consist only of cancellous bone and will therefore be designated as *exostosis spongiosa*, others are covered with a compact layer and are called *exostosis eburnea*. Histological examinations by the clinicians have shown that between the two extremes (the compact and the spongy exostoses) occur all transitions.

Remarks.—The only conclusion that can be drawn from the histological evidence regarding the bony growths in the ears is that they all together constitute but one abnormal complex, which offers numerous individual differences, grades, and variations.

NATURE

What, in the opinion of those who have dealt with the condition, is the nature, pathologically, of ear exostoses? There are numerous opinions on this subject, but in general they are based on limited individual observations, and that mostly clinical, which do not permit of a sufficient perspective and grasp. However, it is interesting to survey these opinions.

Roosa (1866) concluded that ear exostoses "were morbid growths consequent on local irritation."

For Von Troeltsch (1881) the "exostoses" were pathognomically close to tumors, the "hyperostoses" close to diffuse osteophytic growths.

Hedinger (1881) diagnosed his case as "ostoid metamorphosis of inflammatory proliferation of papillary and connective tissue, with lime deposits"—no regular bone formation.

Moos (1881) regarded his cases as simple hyperplasias arising from irritative processes at a time when the tympanic ring fuses with the adjacent parts of the temporal; Roosa, about the same time, viewed them as "hyperplasias of the periosteum and the underlying bone"; Politzer (1893) as "partial hyperplasias of development and ossification."

Steinbrügge (1891) terms the outgrowths "periosteal osteomata." Virchow (1893) considers them as "plainly products of pathological nature . . . examples of disturbed development, which probably begins in and proceeds from the end parts of the annulus tympanicus", and says later, "The localization of the exostoses of the auditory canal implies that they, as the exostoses of other parts of the skeleton, may be conceived as excessive bone growths on places which are advancing toward ossification."

Whitney puts them, *ab origine*, under "cartilaginous exostoses."

Braunberger (1896, p. 6) thought that "if we want to give these exostoses an anatomically and physiologically substantiated position in ear pathology, we must range them with connective tissue tumors in the ectodermal part of the sound-conducting apparatus of the ear."

Ranke (1900) believed that the growths "were examples of an endemic disease common to the burial grounds of Ancon as well as those of old Peru in general."

Sabroux (1901, p. 13) says, "Exostoses of the auditory canal are tumors formed by an abnormal and circumscribed production of bony tissue on the surface of the canal." They are "benign tumors, harmful only by mechanical obstruction."

Mayer (1923, 1924) attaches these exostoses (as also otosclerosis) to the "hamartomata" or defect-developments (Fehlbildungen), and refers them to a defective condition of the periosteal connective tissue.

For Marx (1926, p. 500), "exostoses of the auditory canal represent circumscribed bony neoplasms and are to be counted with the tumors, in distinction from the more diffuse hyperostoses, that belong to the hyperplasias. A sharp division of the two is, however, not always possible, as evidently there are transitional forms and as circumscribed exostoses may also occur in a meatus narrowed through hyperostosis."

Alexander (1930) regards both hyperostoses and exostoses—separable only by their form—when slight as variations, when large as tumors.

Remarks.—It must be clear from the above that the pathognomy of ear exostoses is a subject that is as yet by no means as elucidated as might be desired. The relative rarity of the condition in the living, its clinical disadvantages, the want in many cases of the assistance of an expert histo-pathologist, all constitute serious difficulties in this field. Perhaps the extensive observations that form the basis of this report may help to throw some light on the matter; this will be dealt with in the terminal discussion.

ETIOLOGY

The causation of ear exostoses, being of especial importance to otology, has received considerable attention; nevertheless, here also much still remains obscure. The subject has naturally a direct connection with that of pathognomy of the growths.

A general review of the observations and opinions recorded in this part of the field shows that attention has been concentrated mainly on the local or exciting agencies and on the possible connection of the exostoses with certain systemic conditions or diseases. Nevertheless, there are also a number of valuable observations on the heredity of the growths. It will be well to take up separately the various etiological factors involved.

TRUE CAUSES "UNKNOWN"

A large majority of the authors who deal more adequately with the etiology of ear exostoses acknowledge more or less openly that the true or basic causes of this class of disorders are unknown or uncertain.

Statements such as "nothing positive", "still dark as to the causes", "true causes unknown", and others of similar import may be found in Turner, Blake, Garrigou-Désarènes, Ferreri, Lake, and many others. Hedinger (1881), "pathogenesis entirely unknown"; Whitney (1886, p. 41), "various explanations have been offered for the occurrence of the growth in this situation, but none of these is entirely satisfactory"; Kessel (1889), "causes still but little known"; Goldstein (1898), "etiology often shrouded in mystery"; Politzer (1902, p. 210), "the causes of these exostoses are, in the majority of cases, not ascertainable." Le Double and Lebourg (1903), "causation uncertain"; Bachauer (1909), "cause not yet found"; Burton (1927),

"causes still largely speculative"; Möller-Holst (1932), "subject in many points not satisfactorily cleared."

Notwithstanding this general pessimistic attitude, there are many beliefs and theories as to the causation of the tumors. They will be reviewed in the following sections.

"SPONTANEOUS", NUTRITIVE

There are a number of remarks in otological writings to the effect that an exostosis in the meatus commenced spontaneously without an apparent reason. As late as 1930 Alexander says that some "originate spontaneously, as an abnormality."

Dupuytren (q. by Sabroux, 1901) suggested a nutritive disturbance. He believed that they depended on a modification in the nutrition of the bone, on some sort of aberration in the distribution of the bone juices, comparing the tumors to the outgrowths which develop as a result of irregularity in distribution of sap.

Masini (1882) believed also in disturbed nutrition. He thought the growths "may be comprehended as exaggerated nutritive 'lavosio'."

CONGENITAL

A number of authors have advanced the idea that some of the ear exostoses may be "congenital", though none have taken the trouble to state precisely what they meant by that term. In some cases it probably stands loosely for "hereditary".

Thus Dalby (1876) says, "that small bony enlargements in the external auditory canal are sometimes congenital I feel tolerably confident." Delstanche (1878), a little more explicit, believes that the exostoses "may develop both before and after the ossification of the canal." For Roosa (1892) "there may be congenital cases." Velpeau (q. by Le Double) believed some to be "congenital." For Goldstein (1898) exostoses in American Indians belong apparently to "congenital" growths. Sabroux (1901, p. 24) accepts, though rather loosely, the "congenital" nature of some of these growths: "we call therefore congenital all exostoses whose origin is unknown and which seem to be transmitted by heredity; exostoses whose presence coincides with the development of some congenital tumors or malformations; and finally all those exostoses that characterize one race more than another."

In Bezold and Siebenmann's textbook (1908, p. 102) we read on this subject as follows: "The exostoses in the bony meatus which Virchow found in many Mexican [should be Peruvian] skulls and which he

explained as a peculiarity of the race, must be considered as congenital deformities.”

Fürst (q. by Möller-Holst, 1932, p. 73) regarded the exostoses as possibly congenital, and Green (*ibid.*) held that some of the growths could be of fetal origin.

All ideas of congenitality are, on the other hand, opposed strongly by Kessel (1889, p. 286), who states: “In the literature of the subject there are also met with opinions that the exostoses in the auditory canal may occur congenitally. In my estimate this assumption rests on a gross error, for from developmental studies it is known that in the newborn there is as yet no bony meatus and that the same comes into existence only during the first years of life. . . . The exostoses are therefore later manifestations. . . .” Le Double and Lebourg (1903) express the view that the growths “evidently are not congenital”; and Körner (1904) states unequivocally that they do not occur congenitally.

New observations.—An examination of numerous skulls of fetuses, newborn, and infants has shown me not the slightest trace of what could be regarded as a hyperostosis or exostosis of the tympanic ring, or on the roof of what was becoming the external meatus. As Kessel pointed out, there is no bony canal until well after birth, in early childhood.

Judging from the incomplete developmental stage of the parts up to and for a period after birth, and from the absolutely negative results of our examinations, which included infant skulls of groups that were greatly affected by ear exostoses in later life, it may safely be said, I think, that the growths in question do not occur congenitally. The term “congenital” should henceforth be excluded from the literature of ear exostoses.

DEVELOPMENTAL

Aside from causes inherent in the organism and derived either from some constitutional fault or from heredity, a number of students of ear exostoses connect them with “developmental” conditions of the external auditory canal. Just what is meant by this is mostly not clear, and even where an attempt is made at explanation, no proof of the correctness of the view is given in any instance.

Virchow (q. by Möller-Holst, 1932, p. 73) believed that some of the exostoses originated in the fetal stage from the tympanic ring as a result of a pathological irritation. Much the same view was held by Moos. Green, too, believed that some of the growths could develop in fetal life. For Heiman (1890) congenital ear exostoses were “due

to hyperplasia during the period of development and ossification of the external auditory canal."

Hartmann (1893; 1896, p. 43) held that ear exostoses "must be cases of anomalies of development, because of the simultaneous appearance on both sides, the limitation of the anomaly to pars tympanica, and the perfectly uniform consistency of the rest of the bone." And further (pp. 45-46):

All of these structures are to be regarded as anomalies of formation, which begin with the development of the external meatus and come to light with the advancing of the pars tympanica. . . .

If I were to offer proof that these alterations were simply anomalies of development and had nothing to do with inflammatory or morbid processes, I should emphasize: the absence of alterations which could possibly be referred to previous inflammation; the perfectly uniform condition of the bone, which can in no way be distinguished from the neighboring bone, and especially from that of the squamous portion; the limitation of the hyperostosis to the pars tympanica; the uniform occurrence on both sides; the stationary condition of the tumor in adults; and finally the hereditary influence so often observed.

Lake (1898) opposes Hartmann's opinions. But J. Gruber (1897, p. 212) believes similarly "that the development of ear exostoses stands in connection with the growth of the tympanic ring and is to be conceived as an excess product of this." And for Politzer (1902, p. 210), in some cases the origin of the growths may be attributed to "partial hyperplasia during the stages of development and ossification of the bony auditory meatus." According to his view, "those bilateral osseous neoplasms which develop without symptoms belong to this class, especially if they are located symmetrically in both meatuses and have a corresponding form. They are usually found in the middle and inner sections of the osseous meatus. They are sessile or pedunculated, and seldom attain such a size that they completely fill the auditory canal."

Ballenger (1914, p. 161), too, subscribes to these opinions. He says: "They may be due to developmental causes, particularly in those cases wherein the middle and the inner section of the osseous meatus on each side is the seat of the growth. When due to faulty development, the growths are usually small."

Since the above, the "developmental" origin of ear exostoses received noteworthy further support by Burton (1927). To this observer,

it seems logical to believe that the exciting agent, whatever its form, acts equally upon the entire canal but is responded to only by those points which are especially susceptible to the stimulus. Which are these points? In the vast

majority of cases reported only those areas responded to this stimulation, whatever it was, which during the development grew most rapidly. These places are the two ends of the annulus. By far the larger number of aural exostoses are found along the suture lines between the canal and the rest of the temporal bone. Why? The author believes that an adequate explanation is to be found in his theory that these susceptible areas have retained their early potentiality of more rapid development and response to any stimulus of production.

For Alexander (1930) the "deeper causes of ear exostoses lie in the temporal bone, which is formed of parts that ossify in cartilage and parts formed from periosteal ossification; also the persistence of cartilaginous points in the petrosium, and the lateness of the close of the postembryonal growth, create a disposition to variation in the bone and pathological growths."

Critical remarks.—Although the theory of a "developmental" origin of some, at least, of the ear exostoses has received a considerable backing, yet most of this appears of the order of "follow the leader". And neither the leader nor those who followed have furnished the slightest material evidence that would bear out their contention, or even make it possible.

The discussion under "Congenital Origin" applies also here. There are no observations on record of a fetal, or even later, involvement by the growths up to Field's child of 3 years, and even that case is unique. The bony parts that are to form the external meatus and from which eventually exostoses may arise, are still largely deficient in fetal life and are still far from complete at birth. And irritative ear troubles, that could excite the formation of the outgrowths, are not known of before birth.

INBORN TENDENCY

Wholly different from congenitality is the case of the causes comprised under the term "inborn tendency". Here is something worthy of earnest attention.

The suggestion that there may be behind ear exostoses an inborn tendency toward their production has been expressed by a number of writers on the subject, though one would vainly search for any comprehensive exposition of the idea. Thus Nélaton speaks of a "prédisposition générale de l'économie", and Delstanche (1878), who quotes him, admits this as among the causes. Masini (1882) names "imminent predisposition", and Ostmann (1894) mentions "inborn tendency" as among the causes of the exostoses. For Russell (1900) there is a "tendency in all races towards the formation of bony tumors

or exostoses in the external auditory meatus." A noteworthy statement on the subject is that of Gray (1910):

The other general aspect of the problem is that the majority of individuals never do suffer from exostoses, no matter how badly or from whatever cause their general health become affected, or whether they suffer from some local disease of the ear, such as suppuration, middle ear catarrh, etc., or not. Now it appears to the writer that, viewed from this point of view, the logical conclusion to be drawn is that the cause of exostoses, that is the condition without which the disease cannot occur, is to be found in the organ of hearing itself, and, further, that this condition exists in the organ of hearing of certain individuals, and in these individuals only. From this point of view, which I believe to be the correct one, exostosis is idiopathic. That is to say, the disease occurs in people who have an inborn tendency to it, and that this is the only constant factor in the etiology. No doubt disturbances, either locally in the ears or constitutionally in the bodies of these individuals, may precipitate the onset of the disease, but no particular one of these disturbances need be present and in many cases they may all be absent. The single constant factor is the innate tendency to the disease and the fact that hereditary influences are evident in many cases is strongly in support of this view.

Burton (1927) supports Gray's (and others') view of the presence of an "innate tendency" toward these developments, and would call this "atavism", though evidently with a different shade of meaning from that ordinarily applied to this term. For Möller-Holst (1932, p. 102) a causative connection of atavism is wholly unfounded.

A few authors approach the conception of a "racial influence". Thus Darnach (q. by Alexander, 1930) regards the inclination of the American Indian to ear exostoses as a racial peculiarity (character), something like that of the African Negro toward keloid formations. Möller-Holst (1932) is skeptical and would at most admit a "race-peculiarity" (Rasseneigenthümlichkeit).

Remarks.—The above and some additional statements of this nature range from hesitating suggestions to firm convictions. They show that the more obvious agencies of the disorder did not fully satisfy these observers. They felt more or less vaguely, or have become definitely convinced, that some innate predisposition, individual or racial, lay in the background of the etiology of the growths under consideration. But not one of them has attempted to pin down and critically analyze the hazy factor.

HEREDITY

The subjects of "congenitality", "predisposition", and "inborn tendency", considered above, lead inevitably to that of heredity of ear exostoses, and here otology furnishes a line of definite valuable observations.

As early as 1878, Schwartze reports that he had observed hereditary connections, and Delstanche regards "hereditary predisposition" as among "the best determined causes" of the bony growths in the meatus.

According to Blake (1880, p. 88):

there is one other possible influence which may have a bearing upon the occurrence of these growths, and which is at least worthy of consideration in any future investigations which may be made, and that is, hereditary tendency. Of the more marked cases—that is, cases exhibiting excessive growth without evidence of other aural lesion—I have found, in aural practice, that the majority have occurred in certain families, in the male members of successive generations, the most marked instance being in the three successive generations of one family.

Masini (1882) found positive evidence of heredity of ear exostoses in one case, and similarly did Boyer, Kirchner, Politzer, and Moore. Kessel (1889, p. 288) states that he can confirm the heredity of the growths out of his own clinical experience. There exists here, he says "a constitution-anomaly which leads to certain disturbances in the genesis of the skeleton, without the possibility of a conclusion as yet as to just what this anomaly consists of."

Braunberger (1896) affirms that in individual cases heredity is ascertainable. Hartmann (1897, p. 43) has not only seen evidences of heredity of ear exostoses in his own practice, but a review of the literature on the subject has shown him "the frequent occurrence of hereditary influence in similar cases"; Körner (1904, p. 102) says, "There exists nevertheless in not a few families an hereditary disposition to these bony new growths"; and in Bezold and Siebenmann (1908, p. 102) we read, "This anomaly is often found in several members of the same family."

Gray (1910) states that: "The single constant factor is the innate tendency to the disease and the fact that hereditary influences are evident in many cases is strongly in support of this view." For Ballenger (1914, p. 662), "there are some cases in which heredity seems to be a factor in the production of these growths, as the same condition may be traced through a few generations." O. G. Kessel (1924) declares heredity alone to be the effective cause of the growths, other factors being of but secondary importance. Burton (1927), as already noted, calls the growths "atavisms", which implies inheritance, and asserts that heredity is among the best substantiated of the causes of the abnormalities. For Alexander (1930), ear exostoses are "often hereditary".

Convincing as the above statements are, they are supplemented by the sustaining evidence of actual observations on the heredity of the abnormalities. The reported cases, as far as it was possible to gather them, are as follows:

Reports of Cases of Evident Inheritance of Ear Exostoses

- Blake (1880, 1888): In two families father and son successively affected.
- Masini (1882): In one case, adult male, mother "deaf" through occlusion of both ears when about 40.
- Boyer (q. by Hartmann, 1897, p. 43): Treated a woman whose father, brother, three sisters, two nephews, and all of her own children were affected by ear "hyperostoses."
- Kirchner (1883): Observed a man with bilateral ear exostoses, in whose son he later found a similar condition.
- Kessel (1889, p. 288): Like Blake, saw in two families bony growths in ears of a father and a son.
- Moore (1900): Had two cases, in two brothers, in one in the right, in the other in the left ear.
- Körner (1904, p. 102): Treated, I, a father, 63, with bilateral marked hyperostoses; in his first son, 26, the same; in the second son, 20, the same; in his daughter, 22, a hyperostosis in the right ear; II, father, 55, bilateral marked hyperostosis; son, 7, hyperostosis in the left ear; III, man, 42, bilateral marked hyperostoses . . . brother 38, the same; sister, 30, meatus normal; their cousin, 19, in right ear a completely occluding, coffee-bean-size exostosis.
- Kessel (1924): Presents a heredity-tree of three generations of a family with ear exostoses.
- Alexander (1930): Had three male patients with ear exostoses, the father of each of whom was affected by similar growth; another male whose brother and sister were effected; and still another male with "ear troubles" in a brother and three children of another brother.

Discussion.—In view of the above data, it cannot be doubted that direct heredity plays a part in the etiology of ear exostoses. But there is no light as yet on the problems of how large and important this part is, whether it is generalized or restricted to individual families, whether it is progressive or regressive, and how it originates. Also, nearly all that is said relates to direct inheritance in families and not to heredity in a wider sense. The subject will receive due attention in our final chapter.

An item that calls for some consideration in this place is that of inbreeding. Inbreeding as a cause of ear exostoses was brought up recently (1932) by Möller-Holst, but without comment or any attempt at an explanation. Inbreeding is known to be capable of accentuating and spreading different pathological conditions. In limited localities, in small human groups, and especially in single families, it might have

played a part in multiplying the cases of ear exostoses. But inbreeding means essentially intensified heredity. It could augment but hardly create the exostoses. As these abnormalities are so widespread over the earth, inbreeding, if it was their cause, would have to be equally generalized, which of course it is not. Harmful inbreeding is rare in any race of men. It did not exist in America, where exogamy was the rule. It did exist in Egypt, but only in the Pharaohs and perhaps in the highest families. It took place only very exceptionally in whites. More closely inbred communities, whether in the Old World or the New, have never been reported as especially subject to ear exostoses. In fact, the more closely the subject of inbreeding is examined the more it eludes as a possible cause of ear exostoses.

SOCIAL STATUS: OCCUPATION

There are but a few references to social or occupational causes of ear exostoses, but these few are suggestive. Von Troeltsch (1881, p. 142) states that his cases predominated in those of middle years "who liked to eat well and drink." Bezold in 24 years of hospital and private practice found ear exostoses in 116 patients and says (1895, p. 49): "In only a few instances have I found the exostoses in the dispensary patients; my observations come almost all from private practice. The occurrence of the exostoses is therefore overwhelmingly a disease of the better situated." And the same is reasserted in Bezold and Siebenmann (1908, p. 102).

Körner (1904), in dispensary practice at Rostock, found ear exostoses in but 1.1 percent of his ear patients—a relative rarity in the poor. For Tod (1909) the growths appeared more frequently in the "more favorably circumstanced than in the labouring class." Moodie (1930) mentions that the exostoses are more frequent "among the sedentary groups than among the more active", although he does not state the basis for this conclusion. In Möller-Holst (1932, p. 69) we find the following statement, though it is perhaps not original: "Usually [the ear exostoses] will, curiously, be found almost exclusively among the well-to-do and but seldom in the poor."

Remarks.—Both the social and the occupational factors are of such breadth and complexity, as well as potency, that some influence by them on any pathological or abnormal process may safely be assumed. Such influence may be of direct or indirect nature, primary or secondary. Given the existence of a widespread oto-exostotic diathesis, it is conceivable that its manifestations might be favored or hindered by what is embraced in the term "social status", or occupation. Either

of these complex agencies, in other words, might act as a contributory, exciting, modifying, or checking cause of the abnormalities under consideration.

CLIMATE

The climate of England has been blamed. Law (1909, p. 77) thought ear exostoses were "more frequent in the South, and more so among individuals who have lived in hot climates." Alexander (1930) regards climate as possibly influential in "releasing" the growths. Möller-Holst (1932, p. 69) says—though apparently not as a result of personal observation—that "it is also an interesting fact that the development of exostoses in the external auditory canal occurs more frequently in people who had had a prolonged stay in the tropics"; yet on another page (102) he states that this view is "unfounded".

Remarks.—Our materials hardly sustain the claim for climate as one of the causes of ear exostoses. Our northernmost large group, the Eskimo, is nearly free from the growths; but so is one of the most southern groups, the Egyptians, and so are even more, apparently, the essentially hot-climate African Negroes. The exostoses are frequent along the coasts in Peru, but so they are in the highlands of Peru and Bolivia. The old tribes of the Channel Islands in California and those of Florida, who were equally at least as "oceanic" or litoral as the Peruvians, show much less incidence of these formations. This is particularly noteworthy in Florida, whose old natives belonged largely to the same physical type as those of Louisiana and Arkansas, and where moreover there was a prevalent tendency toward a superabundance of bone formation, as shown frequently by all parts of the skull as well as the skeleton. The greatest involvement by the exostoses is found in tribes of Dakota, Kentucky, Virginia, Tennessee, and Arkansas—all inland regions but differing considerably in climatic conditions. And there is the considerably greater frequency of the growths in the Polynesians than in the Melanesians, with whom the climate is very similar.

From the above it seems that for the present the only safe conclusion to be drawn from the geographical distribution of tympanic exostoses is that their frequency differs very considerably in different territories, but that this is largely, if not entirely regardless of climate or other geographic factors.

FOOD, DRINK, HABITS

Stimulating food and drink.—Toynbee (1860), aside from other considerations, says: "The disease in question may be divided into

two classes: I, appears with congestion of the mucous membrane of the ear. Most of the patients who have consulted me on account of it were in the habit of partaking freely of stimulating food and beverages." Hedinger (1881), on the basis of about 40 cases, found it necessary to deny abuse of liquor as an etiological factor. Heiman (1890) mentions alcohol, but the question is "hard to decide." According to Alexander (1930), food has possibly also "a releasing effect on the exostoses." Möller-Holst (1932, p. 102) says "effect of nutrition is not determinable."

Habits.—Habits in the main imply occupations. With the possible exception of those of sea divers (see under Salt Water), and that of carrying heavy ear pendants (see under Mechanical) no attempts have thus far been made to connect occupational or other habits with ear exostoses.

CONSTITUTIONAL DERANGEMENTS

GOUT, ARTHRITIC DIATHESIS

In dealing with the obscure etiology of ear exostoses it was inevitable that much thought should be given to the possible connection of these abnormalities with those constitutional derangements or diseases that are known to be the cause of osteoblastic disturbances. The foremost of such conditions are the arthritic or gouty diathesis, and syphilis.

The view that rheumatic or arthritic diathesis and resulting localized osteitis or periostitis were the causes of ear exostoses was suggested as early as 1856 by Rau, but was especially fathered by Toynbee (1860), who believed that "it is principally in individuals of rheumatic or gouty temperament that one encounters these bony tumors"; and "they appear to be the result of a rheumatic or gouty diathesis."

Roosa (1866, p. 428), is the first to raise a partial objection—some influence of rheumatic dyscrasia cannot be denied, but must not be overestimated. For Delstanche (1878) the influence of rheumatic or gouty diathesis is not well established. Von Troeltsch (1881) did not see arthritic signs in his cases. For Dalby (1885) the views of Toynbee and similar views are "fallacious"; for Kessel (1889), ascribing the growths to rheumatic or gouty diathesis is untenable.

Virchow (1889, p. 395) is uncertain—"there exists a certain relation between these formations and arthritis deformans"; and in 1893 he is still in doubt—there is "possibly some connection." Jacquemart (1889, p. 192), however, returns to the old view and believes ear exostoses result "from the species of plethora which characterizes arthritism; are found principally in individuals of rheumatic and

gouty temperament." Pritchard (1891), speaking of ear exostoses of certain kinds, says "as far as my own observations go, I am inclined to the belief that they are usually of gouty or rheumatic origin." Alderton (1898) saw in his case "a local gouty manifestation of the constitutional diathesis." For Politzer (1902) gout was one of the causes of the tumors; for Tod (1909) one of the chief causes; and Noquet (1899) saw a case of bilateral ear exostoses in a gouty subject. Sabroux (1901, p. 27) sums up the situation as follows: "Aside from the syphilitic diathesis, we must mention in the etiology of these conditions, arthritism and herpetism, diatheses which are nearly equivalent and closely related if we consider their effects, and finally the gouty diathesis."

For Ballenger (1914, p. 662), gout is doubtful as a direct cause; "it is more probable that the gouty diathesis causes an inflammatory process of the skin and the periosteum, which finally undergoes a retrograde change and becomes the seat of lime deposits."

Remarks.—Arthritic, gouty or rheumatic diathesis is a subject still far from being well understood. It is not even definitely known whether all the conditions comprised under these terms are merely so many differing manifestations of one basic diathesis, as it seems to the writer, or whether they belong to two or more related yet distinct constitutional derangements. They do not, except perhaps on very rare occasions, affect the external auditory canal. They cause irregular osseous deposits in or about the joints, but never pedunculated or circumscribed bony tumors. And they affect mainly those above middle age, whereas exostoses are predominantly an affliction of the earlier part of adult life. A very large proportion of the rheumatic, arthritic, or gouty, moreover never develop ear exostoses. Where then is the connection between the two conditions?

That ear exostoses may exist or develop in "gouty" subjects need not be questioned; that a gouty condition of the system may possibly in some cases act favorably on their development could readily be admitted, though proof should be furnished; that an arthritic diathesis could be the sole cause of an ear exostosis is unexplainable and is opposed by the mass of evidence presented by the extensive skeletal materials at our disposal.

The Eskimo offer perhaps the best refutation of a causal connection between arthritis and ear exostoses. Arthritis is frequent and at times severe in these people, leading to marked joint deposits and marginal exostoses—ear hyperostoses and exostoses are practically absent. On the other hand, in our Kentucky, South Dakota, and Virginia groups, where ear exostoses are most common, arthritic conditions are no more frequent than usual in American material.

SYPHILIS

Syphilis has been blamed for so many pathological conditions of which the causes were difficult to detect that no surprise need be felt that ear exostoses, too, have been attributed to the disease.

The first to believe he saw a direct connection between the two is Triquet (1857, q. by Sabroux), who says "the presence of these bony tumors is not encountered except in subjects manifestly affected by syphilitic infection." Roosa (1866, p. 428) believes that, as with gout, "the influence of syphilis may not be denied, but must not be overestimated". Gruber (1870) thinks syphilis acts in part as a cause; so also, more or less similarly, do Politzer, Jacquemart, Fournier, Noquet, Menière, Krakauer, and Sabroux.

To the above stand opposed Von Troeltsch, Delstanche, Schwartz, Erhardt, and Hedinger. Von Troeltsch (1881, p. 142) says categorically—"connection with syphilis is utterly undemonstrable". Hedinger (1881), as a result of his observations on about 40 cases of ear exostoses, "must exclude syphilis as an etiological factor". For Kessel (1889), ascribing them to syphilis is untenable. According to Duplay (q. by Sabroux, 1901, p. 25), "nothing authorizes us to connect these exostoses with syphilis."

Sabroux (1901, p. 24), though on the basis mainly of the opinions of others, inclines to the view that syphilis is concerned in the genesis of the congenital ear tumors; while in the acquired forms, "syphilis is quite certainly the most common agency that influences their development. . . . In hereditary syphilis we have the congenital exostoses; in the acquired we encounter the exostoses as one of the tertiary manifestations of the disease." And for Ballenger (1914, p. 662), "Syphilis is undoubtedly a cause of the growths, although not in a very large number of cases."

Yet for Bezold and Siebenmann (1908, p. 102) "there is no proof of a special diathesis for this disease such as lues."

There are other statements on the two sides of the question, but no proofs. More recent textbooks and authors in otology tend to be cautious.

Remarks.—Not one single case in the great collection of prehistoric American material that passed through our hands in connection with this study, has shown any evidence of syphilis. Nor was there seen any trace of the disease in any of the Polynesian or other skulls that were found to be affected with ear exostoses.

In the 14 post-Columbian to recent Indian, Eskimo, and White skulls with extensive tertiary syphilitic lesions, in the United States National Museum collections, not one shows even a small ear exostosis.

Whether syphilis, acquired or inherited, may in some way favor the appearance or growth of ear exostoses cannot be decided from my sources. But these do show beyond question that ear exostoses may exist, and that to a far greater extent than in White people, without a trace of syphilis being present; and that on the other hand a whole series of skulls with most pronounced syphilitic involvement may exist with not a vestige of ear exostoses.

LOCAL IRRITATIONS AND INFLAMMATIONS

Of all the possible causes of ear exostoses, none in otological literature receives as much attention as ear irritations and inflammations. The irritations are secondary, due particularly to injuries and discharges, and act by setting up an inflammation. The inflammations may be of any intensity, acute or chronic, localized or generalized. They range from mild focal periostitis or osteitis to serious involvements of the meatus, and to otitis media. All were, and largely still are, believed to be more or less directly influential in favoring the development of the bony growths in the meatus, directly or through their irritating discharges.

Wilde (1855, p. 241) concluded that ear exostoses were the results of chronic osteitis and periostitis in the meatus. Rau (1856) expressed the same opinion. For Toynbee (1860), one class of the growths was due to "congestion of ear lining", secondary to a diseased condition of the ear. Roosa (1866, p. 428) saw in their production a process "substantially an irritative one, often even inflammatory"; "irritation and probably periostitis due to chronic otorrhoea." Similarly for Dalby (1876) they were "at times called into existence by an irritation . . . by the irritating influence of a discharge".

Delstanche (1878, pp. 17, 65) enumerates "among the most potent causes" of ear exostoses, "chronic phlegmasia (inflammation), primary or secondary, of the walls of the meatus . . . inflammation of bone and periosteum . . . inflammation of irritation, spontaneous or traumatic". Similarly, the chief or one of the chief causes of the growths is, in the opinion of Hedinger (1881), "hypertrophic inflammation of the lining membrane, with subsequent osseous metamorphosis of the new-formed connective tissue." For Masini (1882, p. 616), continued local irritation (as in otorrhoea) is a cause of the growths. Moos, Kessel, Politzer, Pritchard, Jacquemart, Heiman, Kuhn, Jackson, Sabroux, Ballenger, Michailowskij, and others express themselves in a more or less similar manner.

For Roosa (1892) the growths are "in general caused by local irritation." Politzer (1902) sees as their basis hypertrophic inflammation of the lining of the canal, with ossification of the new tissue. Virchow (1893) feels that they "owe their inception to a pathological irritation restricted to the pars tympanica." For Green (1896) they are "in most cases, in all probability, the results of a circumscribed periostitis." For Goldstein (1898) "the most tangible and comprehensible cause, yet one not often met with, is that of the long-standing direct irritation and chronic inflammatory condition of the walls of the external auditory canal." McKenzie (1920, p. 458) holds that "exostoses of the meatus seem to be the result of some long-continued irritation, such as chronic suppuration of the middle ear, or eczema of the meatal wall." For Michailowskij (1924, 1926) the chief cause of ear exostoses is chronic *otitis media* and long-lasting dermatitis of the auditory canal. Ballenger (1914, p. 661) tries thus to explain the process: "Chronic suppuration of the middle ear may excite a secondary inflammation of the membranous canal, and cause a fibrous or connective tissue thickening, which, after a long period of time, may be metamorphosed into osseous tissue."

Many other authors, however, express doubt. Field (1878), although acknowledging the influence of inflammatory conditions, nevertheless points out that there is a "rare form of exostosis of ivory consistency, partaking of the nature of a new growth, and quite independent of inflammatory changes." Kessel (1889, p. 287) and after him Schlomka (1891, p. 15) acknowledge that the exostoses occur most frequently in those with chronic ear discharges, and that the discharge causes irritation is beyond doubt; but often it is very hard to decide which was the first condition, for it can be shown that the exostoses are capable of arousing inflammation. Bezold (1895, p. 50) found that "suppurative processes of the middle ear, as accompaniments of exostoses, belong to the great rarities."

Körner (1904, pp. 102-104) feels that the causation of the hyperostoses and exostoses of the meatus by other ear affections is a possibility only in very isolated instances and definitely proved in none; but "there is a rare variety of the exostoses that appears only in consequence of chronic suppuration. These are small buttonlike, fairly pedunculated growths that develop from the postero-superior border of the meatus, close in front of or behind the suprameatal spine and which therefore do not belong, as do the ordinary exostoses, to the tympanic part, but to the squamous portion of the temporal bone." Gray (1910, p. 137) cautions that "judgment must be reserved in this matter"—a large number of the growths are without any symptoms.

Burton (1927) is skeptical as to the influence of otic discharges: "If the exciting agent be some form of chronic irritation and the potentialities of all four walls be equal, we are surely entitled to postulate that the floor, being the most dependent part, would be the wall receiving the maximum stimulation, and hence should be the area most frequently productive of these overgrowths. But the floor is hardly ever involved in the process. It follows therefore that we are justified in premising etiological factors other than chronic irritation. . . ." O. Mayer (q. by Alexander, 1930) does not believe that ear exostoses arise from a primary local inflammation. Möller-Holst's material (1932, p. 102) "fails to show connection with otitis media"; and he has also failed to find, in the mummies with ear exostoses, inflammatory processes in the soft parts.

Discussion.—As with most other alleged causes of ear exostoses, the question remains undecided.

There is no question but that in a large majority of the clinical cases the growths were found accompanied by otorrhoea and in some by marked otitis media. But there were also observed cases without any discharge or otitis, and a great many patients with otorrhoea or otitis media develop no ear exostoses.

A number of the aural surgeons reporting on the condition mention that for long periods the growths caused no trouble to the patient. In general the subject is unaware of the hyperostosis or exostosis until it reaches such a size that it begins to be accompanied by a discharge or interferes with the hearing. But when conditions reach such a stage, a determination of which was first, the bony growth or the discharge and inflammation, is impossible.

The fact that the growths almost never develop from the floor of the meatus, which is most exposed to ear discharges, need not have much significance, for in all probability, owing to differences in innervation and blood supply, not all parts of the tympanic bone are equally prone to the development of exostoses, and at night the discharges bathe also the lateral parts of the meatus.

Theoretically, it cannot but be acknowledged that any cause inducing nerve irritation and reactive prolonged hyperaemia of the meatus would be capable, where a "predisposition" to ear exostoses existed in the parts, of arousing or favoring their development. Where the predisposition does not exist or is held in check in some way, there would, in all probability, be no exostoses. Irritations and inflammations may thus be admitted as among the possible exciting causes of ear exostoses, but hardly as the basic causes of such growths.

The Indian and other material that passed through my hands sustains the view that the fundamental causes of ear exostoses are quite different from mere irritation or inflammation. Most of the specimens with such growths in our collections show no detectable inflammatory changes. Nor are the growths themselves, in a large majority of cases, such as would suggest inflammation. They and the parts about them show nothing like the periostitic bone deposits or osteitic indurations that are so well marked elsewhere in the skull or skeleton where inflammatory processes affected the bone. Our material suggests strongly that, in general, otorrhoea and other otic derangements may not precede but rather follow ear hyperostoses and exostoses, after these have begun to reach an obstructive stage.

SALT WATER

Connected with the preceding category of causes, yet having some individuality of its own, is the irritation of the ear by water and more particularly salt water. A number of authors incline to regard this as a cause of ear exostoses in some instances.

Thus in Field's (1878) cases, two of his four patients attributed their ear troubles, which proved to be exostoses, to repeated and prolonged sea bathing. For Körner (1894) exposure to sea water "was influential"—he found them more than five times as common along the seacoast of Germany as in the interior. Moore (1900, p. 786) reported that ear exostoses were "very common in the Hawaiian Islands, where great fondness for aquatic sports is supposed to be a cause." Tod (1909) blamed "gout and the morning tub." For Law (1909, p. 77) "a causative factor seemed to be the pouring of water into the ears, especially carelessly sponging while holding the head on one side"; and for Jackson (1909) it was "local irritation, principally by sea water." Jackson thought irritation by salt water to be a more frequent cause of ear exostoses than any other. McKenzie (1920, p. 458) says, "they are very common in people who indulge freely in sea-bathing and diving."

For Heiman (1890) the case is "hard to decide." In a case of Lake (1898) the subject "had never had a sea bath." And for Möller-Holst (1932, p. 102) the claim, with some others, is "so unfounded that no discussion of it is necessary."

Remarks.—Some efforts were made to connect the frequency of ear exostoses in the Peruvians and the Channel Islands Californians with sea bathing. It was not known then that the abnormalities would be found to be even much more frequent in some of the inland tribes; that they also occurred in parts of Peru where no one bathed; that they

were rare in the Egyptians who were great water lovers; and that the Malays and the boys of some other maritime groups, including certain Whites, were great swimmers and divers without being particularly troubled with ear exostoses.

Notwithstanding the above, sea water is undoubtedly capable of causing chronic ear troubles, and these may conceivably act, where there is a tendency to the exostoses, as exciting or favoring causes.

ABSCESSSES, FURUNCLES

Cassells (1877) regarded some ear exostoses as secondary to a subperiosteal abscess of the mastoid.

Jacquemart (1889, p. 193) states that after a cure of an ear furuncle or abscess, it is not surprising to see a development of one of these tumors; and Sabroux (1901, p. 29) makes the same assertion.

POLYPS

From evidence adduced by others, Kessel (1889, p. 289) is satisfied that ear polyps may ossify and thus turn into bony tumors. Pritchard (1891) attests that the origin of ear exostoses in some cases may be traced "even to the actual ossification of the polypi." Sabroux (1901, p. 31) quotes Klotz, Bezold, Patterson, Cassells, Hedinger, and Cook as having seen bony tissue in ear polyps, seemingly parting from the bony part of the canal and developing preferentially into the implantation of the tumor (Politzer). Tod (1909) reports a case where a single exostosis developed "from the floor of the auditory canal" 2 years after the removal of a polyp from that ear. Dahlström (1923, p. 216) reports that ossification of ear polyps had been observed by Cocks and Noltenius.

Remarks.—These cases, if correctly reported, would seem to differ substantially from ear exostoses.

MECHANICAL CAUSES AND TRAUMATISM

The first to call attention to the probable influence of mechanical causes on the development of the ear exostoses was Seligmann (1864), who advanced the theory that in ancient Peru the growths were due to the mechanical irritation produced in the Incaic youth, about the time of puberty, by loading the ears with heavy ornaments. This idea is met with also here and there in later authors, and even Virchow (1889, p. 395) inclines to the view that such may have been the cause of the growths in some cases. Blake (1880) found it suggestive that most of the growths occurred in the posterior wall of the meatus, "the wall most exposed to violence."

Politzer believed traumatism might be a cause of ear exostosis, through consequent localized periostitis. Jacquemart (1889, p. 193) claims that even in cases of arthritic or syphilitic diathesis which predisposed to the bony growths in the ears, "it is ordinarily by traumatism that the process commences." More or less similar views are advanced by Heiman (1891), "L. B. of Hamburg", and other authors.

Wagenhäuser (q. by Schlonka, 1891, p. 14) reports a case in which, following a fracture of the anterior wall of the meatus resulting from the kick of a horse, 3 months after the healing of the wound there showed on the site of the injury in the canal two small rounded exostoses.

Contrary to these opinions and reports Kessel (1889) declares that "should one think of mechanical irritation, he will be disappointed. We see foreign bodies remain in the auditory canal for whole decennia, without causing exostosis."

Sabroux (1901, pp. 24, 28) tends to restore the belief in such causes; he says:

A purely *mechanical* cause may also determine deformations of the auditory canal and thereby bring about the production of exostoses. Such an agency might be the compression of the external ear by the umbilical cord when this is coiled about the head. . . . An *injury* of the meatus, however slight, may become the starting point of an exostosis, particularly in those predisposed to such growths through syphilitic, rheumatic, or gouty diathesis; and the same applies to severe traumatisms.

Körner (1904, p. 104) says that "also fractures of the temporal bone, which pass through the auditory canal, may lead to the development of hyperostoses or exostoses in the canal. I have seen two such cases. In both the new bone formation assumed the form of a dull cone and was located on the floor of the canal quite far out toward the mouth of the meatus."

Ballenger (1914, p. 661) holds equally that "traumatic fracture of the walls of the meatus, whereby a circumscribed periostitis is excited, may finally result in the formation of a bony mass or tumor."

Möller-Holst (1932, p. 102) objects to the presumed influence of ear pendants.

There are still other references to the subject of traumatism in otological literature, but they add nothing further.

From the above it appears certain that traumatism of the meatus may in some cases act as the exciting causes for the development of bony growths in the canal. On the other hand no substantial support

is given to the idea that heavy ear pendants might induce the development of these growths, though conceivably in rare cases some exciting influence may exist even in this connection.

HEAD DEFORMATION

Students of ear exostoses who gave attention more especially to American cranial materials, where artificial deformation is frequent, have mostly been inclined to attribute to these deformations more or less influence in the causation of the abnormalities; but there were also those who opposed the view.

There are three main forms of head deformation. One is the simple occipital flattening produced by the unaided or aided pressure of the back of the head on a resistant base. This form assumed its greatest development and vogue among the Pueblos, but it was also present in Florida and elsewhere.

The next form is the "circular" or "Aymara" deformation, produced by a band applied about the head from over the forehead to under the bulge of the occiput. This caused the curious more or less truncated skulls known best from the highlands of Peru and Bolivia, but common also in Vancouver Island, in parts of Argentina, and in other localities.

The third form of head deformation is the fronto-occipital or "flat-head" compression. This was produced by the direct application of pressure to the forehead by means of planks or bags, and occasionally a pad or other appliance for counterpressure to the lower part of the occiput. It prevailed in the Columbia basin, in the southeastern United States, in Mexico and Yucatan, in northern South America, and in Peru. It was also present in Hawaii.

The presumed influence on the development of ear exostoses of artificial skull deformation, ranges itself with the mechanical causes. About the best expression on the subject is that of Whitney (1886, pp. 441-442). He says:

If now the flattened skulls are examined it will be found generally that the meatus is narrowed from before backwards and the lips are often slightly thickened and raised up; . . . There is no absolute demonstration possible that it is the narrowing of the meatus from posterior pressure in early youth that gives a vicious twist to the tympanic ring and places it in a condition favorable to give rise to such outgrowths in after years. All that can be said is that it occurs more frequently in such heads than in those that are normal or flattened by anterior pressure which does not apparently affect the shape of the meatus. And further the similarly flattened heads of the ancient Peruvians show also a large percent affected with hyperostoses. It is not claimed that this deformity is the sole cause, but that it simply increases a tendency which is universal.

For Ostmann (1894), too, the cause of the tympanic exostoses among the American aborigines is largely connected with the deformations of the skull, through its effect on the meatus, which sets up irritation that will lead to exostoses, especially when any other tendency toward such formation exists; with Whitney, he recognizes in the American materials two main causes—"inborn tendency, with head deformation." Goldstein (1898) inclines to a similar opinion; Russell (1900) believes the tendency to bony tumors in the meatus "is increased in deformed crania"; and there are other suggestions of this nature.

On the other hand Turner, as early as 1879, though he found exostoses in a deformed Peruvian and a flat-head Chinook, states that "there was nothing in the two skulls to indicate that the growths may have been induced by the artificial deformation." For Virchow (1893) head deformation was without effect on the production of these growths; for Ten Kate (1896) head deformation had "no connection with ear tumors"; and for Von Luschan (1896) ear exostoses "cannot be attributed to head deformation."

It is plain from the above that the influence of artificial skull deformation on the production of ear exostoses is still problematical.

However, with the observations already on record and the extensive materials that form the basis of this study, it should be possible to throw more definite light on the matter. Let us see how the principal American data on ear exostoses will range themselves in relation to head deformation.

The lessons of the table on page 70 are not as conclusive as might be desired, yet they are not valueless. The records show that undeformed American Indian skulls may be practically free from ear exostoses, may be involved slightly to moderately, as in the Californians, or may present a very marked involvement, as in the Coahuilas. An absence of cranial deformation is therefore no index of freedom from the growths.

There appear in the table several other points worthy of notice. The Argentine Calchaqui, though generally affected by more or less of occipital cradle-board flattening—artificial but very gradual and probably unaided deformation—are, in the available series, free from ear exostoses; and the Vancouver Islanders, all of whose skulls show the artificial circular or Aymara shaping, which in some cases is known to reach very marked degrees on the island, show the growths relatively but very rarely. On the other hand the Chinooks, all of whose heads are deformed by more or less pronounced fronto-occipital flattening, present a very high proportion of the abnormalities.

Older Data on American Indians

Author	Territory	Deformation	Number of skulls examined	Number of skulls with ear exostoses	Percentage of skulls with exostoses
Oetteking....	NW. Coast, misc.	none.....	112
Ten Kate....	Calchaqui.....	generally occipital flattening	110
Russell.....	California.....	none.....	158	2	1.2
Oetteking....	Vancouver Island	all deformed, circular..	260	5	1.9
Russell.....	Peru.....	most deformed, fronto-occipital & circular	447	24	5.4
Alexander....	Amer. Indian, chiefly California	in general, no deformation	550	30	5.5
Virchow.....	Ancon.....	most deformed, fronto-occip.	134	18	13.4
Russell.....	Tennessee & Ohio	most deformed, fronto-occip.	456	69	15.1
Möller-Holst	Chile-Bolivia....	most deformed, fronto-occip.	341	57	16.7
Oetteking....	Chinook.....	all deformed, fronto-occip.	83	23	27.7
Studley.....	Coahuila.....	none.....	22	7	31.8

New observations.—In the next table are given the results of our own series. The indications from these data are hardly better than—in fact, not very different from—those that preceded, but there are confirmations which can hardly be without importance.

In the first place it is now definitely seen that undeformed groups may range widely in the incidence of ear exostoses. This can only mean that the syndrome of these growths exists independently of cranial deformation.

The second synergistic result is that shown by the old Pueblos. A large majority of the skulls of this large group are deformed by the occipital cradleboard compression. In some cases this compression seems to have been aided, is very pronounced, and the whole skull has been affected as a result. Yet this group shows a remarkably low proportion of cases of the abnormal ear growths. It thus ranges itself with

the Calchaqui, who present the same variety of deformation. These results are further strengthened by Hooton, who failed to find any noteworthy involvement in his large Pueblo series from old Pecos. All this justifies the conclusion that the simple occipital cradleboard compression does not favor—and may possibly even check in some way—the development of ear exostoses.

On the other hand the fronto-occipital artificial deformation, produced by the direct and forcible application of pressure over the forehead with a counter pressure on the back of the head, must be viewed with the increasing suspicion that it aids in some way in the appearance of the growths under consideration.

New Data

Author	Territory	Deformation	Number of skulls examined	Number of skulls with ear exostoses	Percentage of skulls with exostoses
Hrdlička	American:				
	Eskimo.....		1,000	2	0.2
	Old Pueblo.....	nearly all deformed, occipital flattening	500	12	2.4
	N. Dakota.....		29	2	6.9
	Florida.....	about 10 percent deformed, fronto-occipital	395	35	8.9
	California.....		435	46	10.6
	NE. States.....		112	13	11.6
	Peru.....	most deformed—mainly fronto-occipital—some circular	3,651	522	14.3
	Virginia.....		65	14	21.5
	Louisiana.....	frequent deformation, fronto-occipital	61	15	24.6
	Arkansas.....	occasional deformation, fronto-occipital	173	47	27.2
	S. Dakota, all.....		109	30	27.5
	S. Dak., Mowbridge		76	23	30.3
	Kentucky.....	only a few deformed, occipital or fronto-occipital	90	29	32.2
	Polynesian:				
	New Zealand.....		19	4	21.1
	Hawaii.....	most undeformed—occasional fronto-occipital	148	39	26.4

This matter may perhaps be more conclusively tested in another way. In six of our series exact records were made of the three main kinds

of deformed skulls (fronto-occipital, circular, and simple occipital), and their aural exostoses. The results came out thus:

Frequency of Ear Exostoses in Undeformed and Deformed Skulls of the Same People, and in the Three Varieties of Deformed

Territory	Percent of skulls with ear exostoses in—			
	Undeformed	Occipital flattening	Circular or "Aymara"	Fronto-occipital or "flat-head"
Peru.....	6.7	14.4 ^a	3.7	18.0
Pueblos.....	2.0	2.5	d. absent	d. absent
Louisiana.....	21.7	deformation absent	absent	26.3
Arkansas.....	21.6	absent	absent	31.8
Florida.....	8.7	absent	absent	12.5
Hawaii.....	23.5	absent	absent	28.3

^a Most, if not all, of these Peruvian skulls are really cases of artificial "flat-head" deformation, but the pressure on the forehead was not sufficient to cause a permanent well-marked flattening of the frontal bone.

In this table, it will be noted, it is possible to compare directly the percentages of specimens with exostoses in each category of the undeformed and deformed skulls, within the same ethnic series. The results are convincing. In every instance where both undeformed and "flat-head" skulls existed in some quantities, the proportion of ear exostoses is distinctly higher in the flat-heads. The fronto-occipital deformation, therefore, it may now for the first time be said positively, favors somewhat the development of the growths.

The simple occipital or cradleboard flattening has evidently but small if any influence on the exostoses; and the circular or Aymara artificial deformation seemingly shows more of a checking than a stimulating effect on the growths.

Just how the flat-head deformation may favor or excite the development of ear exostoses is not clear. Many of these cases of deformation are not of extreme grades, and the skulls that are most deformed do not by any means always show the abnormal ear growths; the occurrence of the latter, in other words, is not directly proportionate to the grade of the distortion.

Where the occiput has been much flattened in these cases—pressed forward—a considerable stress has undoubtedly been transmitted to the parts composing the external bony ear. But much the same com-

pression of the back of the head with similar effects on the ear occurs in some of the cases of the simple occipital flattening, without resulting in tympanic exostoses.

It seems that it is the forcible frontal compression which is mainly to blame. The stresses within the skull produced by the fronto-occipital forcing are certainly greater than those in simple occipital compression. The shape of the external auditory canal is certainly affected in many of these cases. But just how this could give rise to the exostoses is not clear, especially as such growths do not appear to develop earlier in the flat-heads than they do in other crania. Much evidently remains to be learned in these connections.

The simple fact that definitely emerges from our data is that the fronto-occipital head deformation in the newborn of a group is as a rule attended with an increased frequency of development of ear exostoses later in life in that group. The size, forms, and locations of the growths remain apparently unaffected. As to the cause for the increase in frequency, it could be conceived that where artificial head flattening was practiced for a long period of time and favored the development of ear exostoses, the tendency toward these became more and more "alive", and perhaps also the abnormalities became multiplied through direct heredity in families, thus increasing their frequency in the group, even in the undeformed heads. There is probably a kernel of truth in this, though for the present the idea must remain in the category of speculation.

MISCELLANEOUS CAUSES

As in other cases where the causation of a condition is obscure, so with ear exostoses, the students of the subject in the course of time have advanced about the whole gamut of theories that could well be made in this connection. Aside from those dealt with in the previous pages may be mentioned the following:

INBREEDING

Möller-Holst (1932) believes that the pathological ear exostoses, as well as the normal thickening of the tympanic bone such as found in the Eskimo, have arisen through inbreeding (see p. 56).

CONSTITUTIONAL DISEASES (OTHER THAN SYPHILIS AND ARTHRITIS)

Heiman (1890) regarded scrofula as favoring a development of ear exostoses, but only indirectly, through its favoring inflammatory conditions in the auditory canal. There are a few other weak references

to such a possible connection in the earlier literature. Alexander (1930, p. 456) believes some of the growths to "be connected with general constitutional diseases", but does not specify or go further into the subject.

INNERVATION

Toynbee's (1860) class II of ear exostoses "showed symptoms indicative of diseases in the cavities containing the expansion of the auditory nerve."

CONNECTION WITH EXOSTOSES OF INNER EAR, OR OF OTHER PARTS OF THE SKELETON

A connection of meatal exostoses with those of the inner ear was noted by Toynbee, Gruber, Schmaltz. Virchow (1889) saw that in two of his cases the skeleton showed also other exostoses, which suggested a possible connection. Krakauer (1891) was inclined to believe that there was a connection between meatal exostoses and multiple exostoses of the skull. Ostmann (1894) believed the ear exostoses to be due in part to "a tendency to excessive bone production, such as manifested through multiple exostoses."

OTOSCLEROSIS

Burton (1927) attempts to identify the process leading to ear exostoses with otosclerosis. Bezold (1895, p. 50) states that "sclerotic processes in the middle ear do not infrequently coexist with the exostoses."

MASTOID

Rafin and Rougier (q. by Sabroux, p. 22) cite a case of advanced obliteration of the auditory canal by exostoses, in which the mastoids were more developed than the average; Knapp (1898) looked upon some of the ear exostoses—because they are so often posterior—as probably due to primary affections of the mastoid.

MASTICATION

Burton (1927) raises a point which, curiously, has been neglected by other authors. This is the influence upon the meatus of the activity of the lower jaw. He believes "irritation to the aural canal due to mastication to be a contributory factor of aural exostosis." The excess of the growths in the male he attributes to the same factor. But Möller-Holst (1932, p. 102) says the idea of the effect of mastication cannot be sustained.

VESTIGIAL

Whitney (1895) believed "these exostoses must be considered as formed from remnants of fetal cartilage."

NO PATHOLOGY

For Le Double and Lebourg (1903), finally, who examined the ear exostoses in a series of American Indian skulls, the growths were "evidently not of pathological origin."

GENERAL DISCUSSION

Including the records presented in this work, there are few if any pathological conditions of the human skeleton that could command as vast an amount of material as that of ear exostoses, not only clinically, but also, and in much larger measure, racially. This amplexness of material enables the student to see the subject in a much more complete and satisfactory manner than has hitherto been possible. Let us survey briefly what the facts, as far as revealed, indicate.

UNITY OF COMPLEX

About the most important result of the studies is the realization that the subject of ear exostoses, notwithstanding its many variations, represents not a mixture of diverse conditions, but in substance a large unit, a special unit-complex, in the field of human derangements.

While there is a possibility that some of the smaller growths from the deep portion of the roof of the ear, and now and then perhaps an ossification in a polyp, or a hypertrophy following a serious injury, may be formations apart, the great bulk of exostoses in the external meatus constitutes a single human pathological complex-entity. Regardless of any secondary subdivisions of the growths, some of which may be useful, the overwhelming testimony of the evidence is that there is involved but one process—a realization that should facilitate the eventual comprehension of its causes.

RESTRICTION TO MAN

According to all indications the affliction of ear exostoses is purely human—no such growth has ever been observed in the anthropoid apes, any other primates, or any other living forms provided with an external bony meatus. It is apparently one of the penalties of the human estate.

GENERALIZATION IN MAN

Aside from the fact that ear exostoses are limited to the human family, the next major realization is that of the generalization of the tendency to these growths over many if not all the human races. So far the formations have been found in all branches of the human family from which large cranial collections are available. They have not yet been reported in a Negro skull, in that of a Chinese, nor in those of a few other groups, but the numbers of specimens in no one of these cases has been adequate. When sufficient material is available, there are indications that the growths will be found absent in no human aggregate.

VARIED FREQUENCY

Though a tendency toward ear exostoses is probably a pan-human condition, the incidence of the growths varies greatly in different races and groups, and even in different localities. This may be due to differences in the tendency, or to the quantity or effectiveness in a given group or locality of the exciting causes; or both these factors together. The most afflicted, in the order named, are some of the American Indians, the Polynesians, and probably some groups of the Whites; the least affected are the African Negro, possibly the Chinese, and the Eskimo. There is no racial concordance in this and no plain significance, except perhaps as to the African Negro, who in general represents one of the least advanced groups, so far as the brain and head are concerned.

The very marked difference in the incidence of ear exostoses among the American Indians and probably also among the Whites indicates that in some groups and localities the agencies that master the normal status have been further weakened, or that conditions favoring the production of the growths are more potent or common. The term "racial inclination" must be understood in this manner.

GENERAL SIMILARITY

A survey of large and varied series of osteological material reveals: 1, that in general, ear exostoses display, regardless of race or place, essential similarity; and 2, that there is often distinguishable more or less of group or place peculiarities. Thus in one tribe or locality large growth may be frequent; in another, equally involved, they may be scarce. There are also group differences in the exostoses according to their location, in their predominant forms, and in other respects.

It may be said that each more important racial or geographical unit of people will present its own characteristic picture of ear exostoses, though the fundamentals remain much the same. The differences may be of but little import, but now and then are rather striking. All characteristic group differences in these respects must necessarily be connected, on one hand, with the neuro-vascular background of the growths, and on the other hand, with the status of the normal bony structures involved.

NATURE OF THE PROCESS

The syndrome of ear exostosis cannot be regarded as a "disease". Although secondarily it may become pathological and incidentally even fatal, yet in general the outgrowths are quite innocuous, and mostly not even known of, until they grow so large as to become an obstruction or lead to the development of inflammatory conditions. There seems to be no possibility that any bacterial agency is involved in their production, and they are in no sense malignant.

If we exclude all microorganisms and all malignancy, then there remain, it would seem, but two classes of possible causes, the first comprising such "poisons" in the lymph and blood as would be capable of arousing bone tissue to localized bone overgrowths and outgrowths, and the other consisting of derangements of the trophic nerve control of the parts concerned.

"Poisonous", i. e., harmful, substances circulating in the body liquids are certainly present in many individuals, particularly in the later years of life, when the liver, kidneys, and other organs no longer suffice for their neutralization and elimination, and particularly in various pathological conditions and diseases during which poisonous products come into the blood and lymph from pathogenic bacteria.

Granted a "predisposition" to outgrowths in the tympanic bone and the squamous part of the bony meatus, some such poisons as those just mentioned could readily be conceived as the initiators of the exostoses. What many otologists suspected in connection with syphilis, gout, and other constitutional troubles as causes of ear exostoses, was not really these conditions themselves as much as their poisonous products. Mineral as well as organic poisons, such as lead, mercury, alcohol, etc., may also enter the system in other ways. That some such substances may be capable of inciting abnormal osteogenesis where the ground for this is favorable may provisionally be admitted. That any special one or ones can excite the bony growths in the ears, would need an unequivocal demonstration through experiment. That any and all are generally powerless to produce such bony

outgrowths is shown by the very many whose blood and lymph are known to carry such poisons for years, without any effect on the ears. Moreover, such poisons, when present, reach all parts of the ossous system, yet produce nothing resembling the hyperostoses and exostoses of the ear. The case for the internal poisons therefore is not a strong one.

There remains the factor termed conveniently "predisposition". This predisposition must be something limited to the external meatus, for barring rare exceptions, no such bony growths appear elsewhere on the skeleton. But what is the "predisposition"? It can hardly be anything in the mechanics or the structure of the bone—if it were, there would probably be other examples of such a condition and its results elsewhere. There is no evidence that the tympanic bone is unfinished or proliferating in spots. Yet the fault, essentially, can only be with the meatus, or with what controls its structure and being.

If the condition of ear exostoses is, as it appears to be, of the nature of an osteogenic derangement, then it would be reasonable to regard it as the result of a disturbed or weakened trophic control of the parts affected. The development of every part of the body is under a very definite and heredity-bound neuro-vascular control. In the apes and lower forms such control of the external bony meatus is evidently thoroughly established and fully adequate. In man this control appears to be disturbed and no longer wholly sufficient; and with, or even without, sufficient exciting causes abnormal bony growths in the ears are the result. Such a disturbance or weakening could possibly be an accompaniment of the unprecedentedly great and rapid evolution of the human head. Such radical change must have disturbed pre-existing trophic controls, and a full reaccommodation has not yet been reached, at least not in most of the human groups.

Another, though related, way would be to look upon the deranged neuro-vascular control of the external aural canal as an expression of degeneration. Degeneration may be defined as a generalized, progressive groupal insufficiency of the organism to sustain the developmental level reached by an organ. Such insufficiency can again only be based on inadequacy of the trophic nerve centers. It differs diametrically from the inadequacy of accommodation in that it tends to augment with time, whereas the latter tends to diminish, unless the evolutionary changes that caused it keep on advancing.

Can the osteogenic disturbance which results in ear exostoses be regarded as a process referable to a pan-human greater or lesser degenerative condition of the tympanic bone or the external meatus?

Normal, that is, primarily devolutionary and not pathological, organic degeneration follows, as a rule, the reduced use of an organ. Examples of it may be observed in human teeth, appendix, the fifth toe, and other parts that in the course of time have become less active and important than formerly. The changes comprise diminution in size, loss of regularity of shape, diminished vital resistance, and a tendency toward elimination of the part. Has the human ear, or at least the external auditory canal, become less useful and necessary to man than it has been in the lower primates and other animals? The changes here, too, aside from the outgrowths, include diminutions in size (lumen), distortions in shape, and occasionally a more or less complete elimination.¹²

Is the underlying process of ear exostoses, then, a degeneration, or merely a disturbed accommodation—a slowly regressive, or but a somewhat inadequate central control of the neuro-vascular system of the parts involved, with the bony abnormalities as secondary manifestations? It may be best not to attempt any answer to this question before the rest of the available facts on the subject can be considered.

ANTIQUITY

It is not known, and will probably never be determined, when in the existence of man the abnormality of ear exostoses made its first appearance. No case of the growths has as yet been reported in early (geologically ancient) man, and none even from the Neolithic period, though that does not necessarily mean that they were absent.

The oldest skulls in which ear exostoses have been encountered so far are the seven skulls with such outgrowths found by me in the Egyptians of the beginnings of the XII Dynasty, or close to 4,000 years ago. These specimens came from the deep rock-tombs at Lisht and belonged to the higher classes of the people.

The four next oldest specimens with ear exostoses are the skull of an Egyptian (date?) reported by Ostmann (1894), that of an early Christian Nubian Egyptian mentioned by Wood Jones (1910), and the two Egyptian crania found by me in the collection from the Kharga Oasis. Possibly quite as old, or nearly so, are some of the prehistoric American Indian skulls with the growths. Most of the American specimens of such a nature are pre-Columbian; others are post-Columbian but of a period before there was any appreciable influence by the white man. The Hawaiian and New Zealand crania of our

¹² See the writer's "Seven prehistoric American skulls with complete absence of the external auditory meatus." *Amer. Journ. Phys. Anthropol.*, vol. 17, no. 3, 1933.

series are probably all pre-White. The European and American Whites recorded in this connection are all recent, as are also the Chinese, the African Negro, and the Melanesians.

Thus the time in which ear exostoses are known to have existed extends back about 2,000 years before the Christian era. But the frequency of the condition in the prehistoric American skulls is a sure index that the beginnings of the affection are much older—which is about all that can safely be said on the subject for the present.

An even more important question than that of antiquity is that of progression. Have ear exostoses, or have they not, been becoming, however slowly, more frequent? A reliable answer to this query would go far toward the solution of the problem as to whether or not the process is of a degenerative nature; but such an answer is not yet possible.

AGE

Ear exostoses, the data have shown, are encountered from childhood to old age, but the maximum frequency of their development ranges from adolescence to middle age. With no known exception, they begin to form only after the parts they involve have reached full development, and this development, as seen in the affected skulls, barring an occasional diminution in the lumen of the meatus has as a rule been quite normal. This regular normalcy of structure and the delayed manifestation of the growths speak against the basic cause of the abnormalities being of a degenerative nature.

SEX

Ear exostoses are decidedly more frequent in males than they are in females. This phenomenon, moreover, is common to all races, all human subdivisions. What is the meaning of this marked and generalized sex difference?

It would be easy to draw heredity into the picture and speculate on its sex dominance and other effects, especially since there is conclusive evidence that hereditary transmission often does have a part in the spread of these growths. But this method of thinking, with our present knowledge, would lead only to a maze of uncertainties.

Yet heredity in the wider sense is involved in the problem. The pan-human extension of that something in the system that predisposes to ear exostoses can only be sustained as time goes on through heredity; and this generalized deeper heredity apparently finds its effectiveness everywhere enhanced in the males. The females on the whole

are more infantile, less differentiated, organically more conservative; the males more advanced morphologically, less set, more variable. For these reasons the effects of any evolutionary belatedness in accommodation of parts could confidently be expected to show more in the males. This seems likely to be the explanation of the sex difference in the incidence of the abnormal conditions under consideration. There may be assumed, in general, a somewhat greater control of the normal conditions of the tympanic bone and the external meatus as a whole in the females.

An interesting fact in this connection is that according to prolonged observations by otologists, ear troubles and diseases in general are more common in the males than in the females. There is however one notable exception and that is atresia or congenital defect of the external meatus; this serious agenetic defect is considerably more common in the females, particularly in certain human races.¹³

SOCIAL STATUS

A number of authors, it has been seen, have voiced the opinion that, among the Whites at least, ear exostoses occur predominantly in the well-to-do classes. If this is so—and there is no voice to the contrary—the question would arise, what is there in the wealthier class that favors the abnormalities?

Here is a promising line of inquiry, but the foundations for it need to be strengthened. All that may be said now is that being “well-to-do” means, on one hand, usually more leisure and what this carries with it, on the other hand, a greater preservation of the weaker—which, together, may conceivably lead in time to some weakenings or derangements of the basic neuro-vascular controls of different parts of the organism.

SIDE

In materially over one-half of the cases of ear exostoses, on the average, the affliction is bilateral and frequently more or less symmetrical. This points strongly to the conclusion that the basic cause of the growths lies centrally in the nervous system. That not all cases are bilateral is due probably to developmental differences of the bones of the meatus in the two ears. It is well known that no two bones are exactly equal, macroscopically and microscopically, on the two sides.

In the unilateral cases, there is perceptible a general tendency for the exostoses to be more frequent in the left ear. In clinical experience

¹³ See the writer's report on the condition, *Amer. Journ. Phys. Anthropol.*, vol. 17, no. 3, 1933.

with ear troubles as a whole, according to extensive statistics, "the left ear becomes diseased more often than the right", in the proportion of about 5 to 4 (Bürkner, 1883, p. 103). The significance of this eludes us for the present.⁴⁴ In this connection it must not be forgotten that not a few one-side cases tend with time to become bilateral.

CONSTITUTIONAL DISEASES, LOCAL PATHOLOGICAL CONDITIONS, TRAUMATISMS, IRRITATIONS

None of these conditions is associated with ear exostoses, except on more or less infrequent occasions. Examinations of osseous materials show that in cases where gout, arthritis, or syphilis have run unchecked to their limits, there are generally no ear exostoses. These diseases, as well as most of the local irritative conditions affecting the external meatus, can occupy no more than a secondary place in the etiology of the abnormal growths. They can probably all be accepted as occasional exciting, but not as the original, causes, except perhaps in the case of certain traumatismes of the bones composing the meatus. The real, the predisposing, cause is different: it is deeper and is generalized over most if not all human groups.

THE GENERAL CAUSE

On the basis of the extensive materials reported in this work and after all preceding considerations of the etiology of ear exostoses, both by other authors and the writer, it seems possible now to approach certain generalizations that hitherto were impossible.

Let us fix our minds once more on the essential facts of the subject under consideration. These are: an apparently complete absence of the process in animals, including the primates; a generalized predisposition to it in recent and present man; the absence or rarity of developmental defects; the predominance of the manifestations from the post-pubertal to presenile time of life; the excess of involvement in the males; the marked tendency of the growths to bilaterality and even symmetry; and their ascertained occasional direct inheritability.

All this, as seen in previous discussion, points to the conclusions that ear exostoses constitute a special complex or entity belonging not in the field of diseases but in that of abnormalities, and that they must be directly connected with neuro-vascular derangements, which

⁴⁴ Here again, curiously, the serious defect of ear atresia forms an exception, being considerably more common, especially in the American Indian, on the right side.

may be excited locally by different agencies, but which have their seat in the trophic nervous centers that control the bony structures of the external auditory canal.

There remains to be considered the general cause of the neurocentric derangement and insufficiency. It was seen that two possible agencies suggested themselves in this connection. One of these is degeneracy, the other incomplete or disturbed evolutionary adjustment.

The disgenic character of the ear growths would seem to point to a degenerative cause affecting the aural apparatus—they tend to lead to loss of hearing, local troubles, and indirectly, in rare cases, even to death. Another item that might conceivably support the view of a degenerative cause of ear exostoses is the fact, long known in otology (see Bürkner, 1883, p. 103), that “the disposition to ear troubles (in general) rises from birth to the 40th year and thence diminishes with age”, which might be viewed as evidence of a degenerative condition regarding the ear and which bears a close relation to the age incidence of the ear growths. The much greater prevalence of ear exostoses in the males than in the females, in all the human groups known to show the abnormalities, might be viewed as a further support for the idea of a basic degenerative cause, for the males as the less stable or conservative sex might be expected to make just such a showing.

But there are serious difficulties in the way of the hypothesis of degeneration. The most potent are: There is no evidence that the human ear is falling into disuse and hence would be starting on the way to degeneration and restriction or elimination; ear exostoses affect not the organ of hearing proper, but the relatively much less important bony passage that leads to the hearing apparatus itself; the exostoses as a rule are not accompanied by congenital defects in the parts involved; they are associated with few and followed by very few, if any, changes that could possibly be looked upon as of degenerative nature of either the ear as a whole or of the meatus; once successfully removed by the surgeon they generally leave a sound ear with normal function and but rarely recur; the process of the production of these growths is in substance an excess of production rather than any expression of structural weakness or defective vitality such as usually result from degenerative causes; and although they may be transmitted to the progeny, the ear exostoses recur as such and not, so far as known, in the form of any congenital defects of the meatus.

It appears from the above that there is more that speaks against than for a degenerative cause in the background of ear exostoses.

There remains to be considered the central neurotrophic maladjustment. It is plain that all structures in the body must be formed and

maintained under the direction of special nervous centers, which as yet are known but very imperfectly but the existence and regulatory function of which are necessary, and which are called the trophic centers. They are highly important parts of the central government of each individual organism. They act upon the blood and lymph supply and doubtless also in other effective ways. The tissues themselves can have no architectonic individuality; they are but so much living material from which, under the strongly hereditarily fixed specific influence of the nervous centers, there are built different structures. Nor does the function of these centers end with the finish of the construction, just as the function of the government of a city cannot end with the completion of its streets and houses. There is a perpetual guardianship under the continued power of heredity, and there are perpetual changes, for heredity is not fully discharged or satisfied with the completion of the structures—it is a lifetime factor. And here, I feel, lies the clue to the problem that confronts us in our study of ear exostoses.

It may safely be regarded as axiomatic that as long as both the heredity and the nervous apparatus that subserves it in connection with any given part of the organism are normal, that part will, unless in some way injured, remain normal. If in the absence of a chemical, mechanical, or bacterial injury a part behaves abnormally, it is an unquestionable proof that at that point and to that extent there is either a weakening or derangement of the hereditary control, or of its proper transmission. The something we call heredity must not be conceived as any special power acting within and upon an organism—it can in the end consist only of a specific organization within and between the molecules of the cells of the nervous centers. Such organization is as a rule deeply fixed and not readily influenced. It may however be affected by deep-acting causes. Just what such causes are and how they may act, except in case of destructive bacterial or other poisons, is still but little known.

What from the above discussion can help us toward an understanding of the basic cause of ear exostoses? Can it be a weakened or temporarily disturbed heredity, or does the cause lie in a faulty or temporarily disturbed mechanism of nervous transmission of the hereditary control?

Both the above conditions are possible, but the wide prevalence of ear exostoses in the human family, and their manifestations as to age, sex, and side, seem to speak against derangements of nerve transmission.

This leaves as the most probable basic cause of ear exostoses a weakening or derangement of the normal hereditary control of the tympanic bone and parts adjacent. With this conclusion we must rest for the present, for while it was possible to proceed thus far by the use of logic, a further delving into the subject, until there have accumulated additional reliable data, would entail pure speculation.

Only one thought, already touched upon, may here be permissible, but that must not be taken for an assertion. It concerns man's astoundingly rapid evolution and changes—geologically and morphologically. Within some 500,000 years man's progress, especially as concerns his brain and head, has far outstripped that of all the rest of creation. This rapid progress and differentiation, with a spread to all regions and exposure to a multitude of new factors, has prevented in many respects a full adjustment of all parts, a full harmonization and stability in all regions. There is a possibility that the central trophic control of the external meatal region, in the greatly enlarged, altered and still altering skull, has not regained the full life-long adequacy that it possessed before. This would mark the abnormality under consideration as an incidental condition, one that might disappear in the natural course of events, if further skull changes affecting the part stopped and if direct inheritance of the abnormality did not meanwhile become rooted. Should this conception prove to be true, then the process of ear exostoses could be defined as that of irregular outgrowths of bone in the external bony auditory canal and principally from its tympanic part, due primarily to evolutionarily-weakened normal neuro-vascular control of the parts.

One other item demands a brief consideration in these connections. It is that of a possible disturbing, and hence causative, influence of the sex hormones. As seen, ear exostoses develop most frequently during the period of major sexual activity. Also they are more common in the male, in whom the sex activity is more intense. This attractive "clue", however, proves disappointing. Perhaps no race, particularly as regards the males, is more active sexually than the Negro—yet ear exostoses are very rare if not absent. There are so many such incongruities, racial and individual, that this promising lead must be abandoned.

SUMMARY

Ear exostoses are neither a constitutional, nor infectious, nor malignant disease. They do not even properly deserve the name of disease, being but secondarily pathological and that mainly through obstruction or pressure. They are abnormalities rather than a disease.

Ear exostoses are localized hyperplasias, or outgrowths, from essentially the tympanic part, but occasionally also from the squamous portion, of the external bony meatus.

They arise generally from what were the free upper ends of the tympanic ring. Their development belongs chiefly to the later adolescent period and the earlier half of the adult period.

A "predisposition" to ear exostoses is now probably universal in man, but in some races or groups the formation of the abnormalities, owing perhaps to direct hereditary effects, is much more frequent than in others.

Males are considerably more subject to the growths than females, the well-to-do (in Whites at least) more than the poor. The affection is most frequently bilateral, and where one-sided, it occurs somewhat more commonly in the left than in the right ear.

Structurally, the growths range from cancellous to compact, without any definite segregation. Though macroscopically the bone is often more or less aberrant, its elements are normal and remain viable. There is never any breaking down or necrosis, nor a complete calcification.

The causes are systemic or "predisposing", and exciting. The paramount systemic cause appears to be a deranged neuro-vascular control of the parts involved, chiefly the tympanic bone, during what corresponds to the sexually more active part of life; but on critical consideration it becomes apparent that no connection of the exostoses with sex activity can be ascertained.

What causes the peculiar time-limited neuro-vascular derangement that predisposes or leads to ear exostoses cannot yet be definitely established, but it appears to be something in the hereditary endowment of the trophic nervous centers that control the normal status of the external bony meatus. A deranged accommodation of evolutionary nature suggests itself, rather than degeneracy, as a plausible explanation.

The exciting cause of ear exostoses, where the predisposition to these exists, may be anything mechanical or chemical that produces prolonged irritation, with consequent hyperaemia to inflammation, of any part of the bony meatus.

BIBLIOGRAPHY

AICHEL, O.

1931. Diskussionsbemerkung zu Möller-Holst: Über Gehörgangsexostosen usw. Sitzungsber. Ges. Phys. Anthrop., Breslau.

ALDERTON, H. A.

1898. Some unusual aural cases. *Ann. Otol. Rhin. and Laryng.*, vol. 7, no. 1, pp. 115-118.

ALDINGER

1876. Zwei Fälle von Exostosen in äusseren Gehörgang. Arch. Ohrenheilk., vol. 11, pp. 113-120.

ALEXANDER, G.

1928. Diskussionsbemerkung. Wiener Röntgen-Ges. Sitzung vom 8 Mai, Wiener med. Wochenschr., no. 40.
1930. Zur Kenntnis des Schläfenbeines des amerikanischen Indianers. Monatsschr. Ohrenheilk. und Laryngo-Rhin., vol. 64, pp. 17-270. Wien.

AMBERG, EMIL

1910. An irregular pear-shaped bone formation in the mastoid process. New York Med. Journ., vol. 92, p. 799.

AUTENRIETH, J. H. F.

1809. Arch. Physiol., vol. 9, p. 349. Halle.

AYRES, S. C.

1881. Exostoses of the external auditory canal. Arch. Otol., vol. 10, no. 4, pp. 327-384. Also translated in Zeitschr. Ohrenheilk., 1882, vol. 11, pp. 95-100.

B., DR. L. in Hamburg

1875. Zur Casuistik der Knochengeschwülste des äusseren Gehörganges. Arch. Ohrenheilk., vol. 10, pp. 110-118.

BACHAUER, J.

1909. Anthropologische Studien über den äusseren Gehörgang. Inaug.-Diss. phil. München.

BALLENGER, W. L.

1914. Diseases of the nose, throat and ear, medical and surgical. 4th ed., Philadelphia and New York.

BAUER, J., and STEIN, CONRAD

1926. Konstitutionspathologie in der Ohrenheilkunde. Berlin.

BENSON, A. H.

1885. Ivory exostosis of the external auditory meatus. Trans. Roy. Acad. Med. Ireland, vol. 3, pp. 158-163.
1889. On exostoses of the external auditory meatus. Trans. Roy. Acad. Med. Ireland, vol. 7, pp. 108-113.

BEZOLD, F.

- 1872-1884. Aerztl. Intell. Blatt., no. 40 et seq., 1872; no. 26 et seq., 1875; no. 44 et seq. 1878; no. 26 et seq., 1881; no. 49 et seq., 1884; and Arch. Ohrenheilk., vol. 21, p. 221.
1885. Schuluntersuchungen über das kindliche Gehörorgan, p. 2 et seq.
1895. Übersicht über den gegenwärtigen Stand der Ohrenheilkunde. Weisbaden.

BEZOLD, F., and SIEBENMANN, F.

1908. Text-book of otology. Translated by J. Holinger, Chicago.

BILLROTH, C. A. THEODOR

1893. Allgemeine chirurgische Pathologie und Therapie in Einundfünfzig Vorlesungen.

BLAKE, C. J.

1880. Exostoses in the ear canals of Mound Builders. *Trans. Amer. Otol. Soc.*, vol. 2, pp. 417-419. Boston.
- 1880a. On the occurrence of exostoses within the external auditory canal in prehistoric man. *Amer. Journ. Otol.*, vol. 2, pp. 81-91. New York.

BONNAFONT, J. P.

1863. Mémoire sur trois cas de guérison de surdités produites par des tumeurs osseuses développées dans le conduit auditif externe. *Bull. Acad. Méd.*, vol. 29, pp. 29-41.
1868. Observation d'un cas de surdité complète de l'oreille gauche, due à l'oblitération du conduit auditif externe par un tumeur osseuse (exostose) siégeant près la membrane du tympan. Lue à l'Académie Impériale de Médecin, Mai, 8 pp.
1868. Review of Von Troeltsch's "Maladies de l'oreille", translated by Sengle. *L'Union Méd.*, ser. 3, p. 736 et seq. Paris.

BRAQUEHAYE, J.

1901. Les exostoses du conduit auditif. *Bull. l'Hôp. Civ. Franç. Tunis*, vol. 4, pp. 157-169.

BRAUNBERGER, E.

1896. Über die Exostosen des äusseren Gehörganges. Strassburg.

BREMER, V.

1878. Du traitement des tumeurs osseuses du conduit auditif. *Ann. Mal. de l'Oreille et du Larynx*, vol. 4, pp. 316-320. Paris.

BRÜHL, G.

1919. Zur Histologie gestielter Gehörgangsexostosen. *Zeitschr. Ohrenheilk. und Krankh. Luftw.*, vol. 78, p. 17.

BURCKHARDT-MERIAN, A.

1880. Statistische Zusammenstellung der in den Jahren 1874-79 in meiner Poliklinik und Privatpraxis behandelten Ohrenkranken. *Arch. Ohrenheilk.*, vol. 16, p. 84.

BÜRKNER, K.

1878. Kleine Beiträge zur normalen und pathologischen Anatomie des Gehörganges. *Arch. Ohrenheilk.*, vol. 13, pp. 163-195.
1884. Beiträge zur Statistik der Ohrenkrankheiten. *Arch. Ohrenheilk.*, vol. 20, pp. 81-103.

BURNETT, C. H.

- 1887-1890. The successful removal of an exostosis from the external auditory meatus by means of bone forceps and chisel. *Trans. Amer. Otol. Soc.*, vol. 4, pt. 1, p. 28 et seq.

BURTON, F. A.

1923. Aural exostosis. *Ann. Otol. Rhin. and Laryng.*, vol. 32, pp. 99-117.
1927. Some considerations on prehistoric aural, nasal, sinus pathology and surgery. Santa Fe, N. Mex. (38 pp., no bibl.).

CARR, LUCIEN

1878. Observations on the crania from the stone graves in Tennessee. *11th Ann. Rep. Peabody Mus.*, p. 381 et seq. Cambridge.

CASSELLS, J. P.

1874. Otological memoranda, being clinical observations illustrative of the diseases and injuries of the ear. *British Med. Journ.*, vol. 1.
1877. On the etiology of aural exostoses. *British Med. Journ.*, vol. 2, p. 845.

CHEATLE, A. H.

1907. Some points in the surgical anatomy of the temporal bone from birth to adult life. London.

1910. Report. Proc. Roy. Soc. Med., vol. 3, pt. 3, Otol. Sect., p. 77.

CLARK, T. E.

1873. Electrolysis of exostosis of the ear. British Med. Journ., vol. 2, p. 656.

COCKS, D. C.

1883. Pedunculated bony growths in external auditory canal, the result of long continued suppuration; removal by snare; microscopic examination. Arch. Otol., vol. 12, pp. 59-62; also in Zeitschr. Ohrenheilk., vol. 13, p. 172.

CONNAL, J. G.

1901. Multiple exostoses in both external auditory canals. Glasgow Med. Journ., vol. 56, p. 291.

DAHLSTRÖM, WALTER

1923. Ein Fall von gestielter Exostose der äusseren Gehörgangswand. Acta Oto-Laryngologica, vol. 5, pp. 213-217.

DALBY, W. B.

1876. Closure of the external auditory meatus. Lancet, vol. 1, p. 126.

1885. The removal of bony growths from the external auditory canal. Proc. Roy. Med. and Chir. Soc., vol. 2, p. 400 et seq.

1889. Discussion on the removal of bony growths from the external auditory canal. British Med. Journ., vol. 2, pp. 704-709.

DAVIS, J. B.

1867. Thesaurus craniorum, London; supplementary vol., London, 1874.

DE ARLI, D.

1903. Atti della clinica oto-rino-laringoiatrica della R. Università di Roma, anno 1.

DELSTANCHE, C. (fils)

1878. Contribution à l'étude des tumeurs osseuses du conduit auditif externe. Mém. Acad. Roy. Méd. Belgium, vol. 5, 66 pp.

DENKER, A., and ALBRECHT, W.

1925. Lehrbuch der Krankheiten des Ohres und der Luftwege. Jena.

DE ROSSI, E.

1876-1883. Berichte der Poliklinik für Ohrenkranke in Rom. Abstracted in Arch. Ohrenheilk., vol. 11, p. 89; vol. 13, p. 265; vol. 15, p. 169; vol. 17, p. 132; vol. 19, p. 81.

1885. Cenni statistico-clinico per l'anno scolastico, 1884-85.

DORSEY, GEORGE

1894. Crania from the necropolis of Ancon, Peru. Proc. Amer. Assoc. Adv. Sci. for 1894, pp. 360, 361.

ERHARDT, JULIUS

1875. Vorträge über die Krankheiten des Ohres gehalten an der Friedrich Wilhelms Universität zu Berlin, p. 173. Leipzig.

EULENSTEIN

1899. Movable spongy osteoma of the cartilaginous portion of the external auditory meatus. Arch. Otol., vol. 28, pp. 35-37; also in Zeitschr. Ohrenheilk., vol. 34, p. 40.

FERRERI, G.

1904. Esostosi del condotto uditivo esterno. *Arch. Ital. Otol.*, vol. 15, pp. 353-365. Torino.

FIELD, G. P.

1878. Case of ivory exostosis in both ears. *Lancet*, vol. 2, p. 81.
 1878a. On the etiology of aural exostoses; osseous tumour following extraction of polypus. *British Med. Journ.*, vol. 1, p. 152.
 1882. Diseases of the ear, pp. 69-90. London.

FLOWER, W. H.

1879. Catalogue, pt. 1, 1st ed.; 2d ed. London, 1907.
 1881. Fashion in deformity. London.

FÜRST, CARL

1914. Ur Fornvännern. Skelettfynd från stenåldersgravar i Nerike samt nagot om vår stenålders befolknings sjukdomar och åkommor.

FÜRST, C. M., and HANSE, FR. C. C.

1915. *Crania Groenlandica*. Copenhagen.

GARDINER-BROWN, A.

1880. Ivory exostosis deeply seated in the external auditory meatus; removal. *Lancet*, vol. 1, p. 396.

GARRIGOU-DÉSARÈNES

1888. Des tumeurs osseuses du conduit auditif externe et de leur ablation; observations. *Rev. Mens. Laryng.*, vol. 8, pp. 6-15.

GATSCHER, S.

1929. Hyperostosen beider Gehörgänge mit Difformität des Warzenfortsatzes. *Monatsschr. Ohrenheilk. und Laryngo-Rhin.*, vol. 63, pp. 965-966.

GOLDSTEIN, M. A.

1898. Exostosis of external auditory canal. *Journ. Laryng. Rhin. and Otol.*, vol. 13, pp. 338-342.

GRAY, A. A.

1910. *The ear and its diseases*. New York.

GREEN, J. O.

1878. Exostosis of the auditory meatus; death from meningitis. *Boston Med. and Surg. Journ.*, vol. 98, pp. 494-502. Reference to in *Zeitschr. Ohrenheilk.*, vol. 8, p. 101, 1879.
 1896. Von einer Knorpelhülle umgebenes Osteom des Ohres. *Arch. Ohren-, Nasen- und Kehlkopfheilk.*, vol. 40, p. 142.

GRUBER, J.

1870. *Lehrbuch der Ohrenheilkunde*, p. 415.
 1863-1881. Berichte über die auf der Klinik des Dr. J. Gruber, Ohrenarztes des K. K. allg. Krankenhauses, ambulatorisch behandelten Ohrenkranken. *Aerztl. Ber. k. k. allg. Krankenhauses in Wien auf die Jahre 1862-1880*.
 1897. Discussion. *Monatsschr. Ohrenheilk.*, vol. 31, p. 212.

GRUBER, W.

1875. Eine Exostose im Porus auditorius externus. *Arch. Path. Anat. etc.*, vol. 65, pp. 14-16.

HARTMANN, A.

1893. Discussion. Berlin. Klin. Wochenschr., vol. 30, p. 636.

1896. Über Hyperostose des äusseren Gehörganges. Zeitschr. Ohrenheilk., vol. 30, pp. 48-52. Translated by J. A. Spalding, Arch. Otol., vol. 26, pp. 43-46, 1897.

HAUG, R.

1894. Beiträge zur Würdigung der Hyperostose des Felsenbeines. Arch. Ohrenheilk., vol. 37, pp. 161-198.

HAYMANN, D.

1918. Zur Kenntnis der Knochengeschwülste des Warzenfortsatzes. Wiesbaden.

HECKE

1893. Operative Entfernung einer Exostose des rechten Gehörganges. Deutsche Med. Wochenschr., vol. 19, p. 552.

HEDINGER, A.

1879. Über Exostose im äusseren Gehörgange und ihre Behandlung. Zeitschr. Ohrenheilk., vol. 8, p. 379. Translated in Arch. Otol., vol. 9, p. 3, 1880.

1881. Über eine eigentümliche Exostose im Ohr. Zeitschr. Ohrenheilk. und Krankh. Luftw., vol. 10, p. 49. Translated in Arch. Otol., vol. 10, pp. 47-54.

HEIMAN, T. H.

1890. A case of operation for exostosis of the external auditory meatus. Arch. Otol., nos. 2-3, pp. 144-151.

HELFRICH, C. H.

1895. Exostoses of auditory canal; operations with dental engine. Homeop. Eye, Ear and Throat Journ., vol. 1, pp. 39-43.

HENKE, F., and LUBARSCH, O.

1926. Handbuch der speziellen pathologischen Anatomie und Histologie.

HOFMANN, LOTAR

1926. Zur Anatomie des Primaten-Schläfenbeines und seiner pneumatischen Räume unter Berücksichtigung des menschlichen Schläfenbeines. Monatsschr. Ohrenheilk., vol. 60, pp. 921-949.

HOVELL, T. M.

1894. Removal of an exostosis of the auditory meatus by combined drilling and traction. British Med. Journ., vol. 1, p. 1302.

HRDLIČKA, ALEŠ

1911. Some results of recent anthropological exploration in Peru. Smithsonian Misc. Coll., vol. 56, no. 16, 16 pp., 4 pls.

1914. Anthropological work in Peru in 1913. With notes on the pathology of the ancient Peruvians. Smithsonian Misc. Coll., vol. 61, no. 18, 69 pp., 26 pls.

ITARD, J. E. M. G.

1821. Traité des maladies de l'oreille et de l'audition. Paris.

JACKSON, G.

1909. The etiology of exostoses of the external auditory meatus. British Med. Journ., vol. 2, 1137-1138.

JACQUEMART, ALGER

1885. Observation d'une exostose du conduit auditif externe; opération et guérison. Congr. Intern. Otol. Compt.-Rend. Bâle, vol. 3, pp. 329-333; also in Alger Méd., vol. 12, pp. 368-373, 1884.

1889. Communication à propos de deux cas d'exostoses du conduit auditif externe. Rev. Laryng., etc., vol. 9, pp. 189-195 and 218-227.

JONES, F. WOOD

1910. General pathology. Arch. Surv. Nubia, vol. 2: Report on the human remains (by G. Elliot Smith and F. Wood Jones). Cairo.

KAREWSKI

1892. Multiple Exostosen am Schädel und Gesicht mit halbseitiger Gesichtsatrophie. Deutsche Med. Wochenschr., no. 3, p. 57.

KAUFMANN, E.

1922. Lehrbuch der speziellen pathologischen Anatomie. 7th and 8th eds. Berlin and Leipzig.

KELSON, W. H.

1900. Case of aural exostoses. Journ. Laryng. Rhin. and Otol., vol. 15, p. 666.

KERRISON, PHILIP D.

1913. Diseases of the ear. Philadelphia and London.

KESSEL

1889. Über die Exostosen des äusseren Gehörganges. Cor.-Blat. Allg. Ärztl. Ver. Thüringen, vol. 18, pp. 284-298. Weimar.

KESSEL, O. G.

1924. Exostosenstammbaum. Zeitschr. Hals- Nasen- und Ohrenheilk., vol. 8, pp. 266-271.

KIRCHNER, W.

1883. Bericht über die Verhandlungen der otiatrischen Section der 56. Versammlung deutscher Naturforscher und Ärzte in Freiburg. Arch. Ohrenheilk., vol. 20, p. 289.

KNAPP

1898. Exostose obturante après l'ablation (etc.). Ann. Mal. de l'Oreille, Larynx, etc., vol. 24, p. 82.

KNAPP, H.

1886. Totale Entfernung einer Elfenbeinexostose, die den Gehörgang ganz ausfüllte; Heilung. Zeitschr. Ohrenheilk., vol. 15, pp. 314-317.

KÖRNER, O.

1894. Gestielte Exostosen neben der Spina supra meatum. Monatsschr. Ohrenheilk. und Laryngo-Rhin., vol. 28, p. 355.

1904. Die Exostosen und Hyperostosen im Gehörgange und die Osteoma in den Operationshöhlen des Schläfenbeines. Zeitschr. Ohrenheilk., vol. 48, Ergänzheft, pp. 100-108.

KRAKAUER

1891. Ein Fall von multipler Exostosenbildung am Schädel mit halbseitiger Gesichtsatrophie. Monatssch. Ohrenheilk., no. 10, pp. 261-263.

KRÄMER, W.

1837. The nature and treatment of the diseases of the ear. Translated by J. R. Bennett, London.

KREPUSKA

1898. Exostoses développées au cours de, etc. *Ann. Mal de l'Oreille et Lar.*, vol. 24, p. 439.

KRETSCHMANN

1910. Osteome an Schädelknochen. *Verhandl. Deutsche Otol. Ges.*, pp. 305-318. Dresden.

LAKE, R.

1898. Aural exostoses. *Journ. Laryng. Rhin. and Otol.*, vol. 13, p. 383.

LAW, E.

1909. Discussion. *Proc. Roy. Soc. Med.*, Pt. 3, Otol. Sect., p. 77.

LE DOUBLE, A. F.

1903. *Traité des variations des os du crâne de l'homme*, pp. 326-327. Paris.

LICHTENBERG

1891. Ein Fall von Osteom in äusseren Gehörgang. *Pester Med. Chir.*, no. 12, pp. 270-271. Presse.

LUCAE, A.

1879. Statistische Übersicht über die vom 1. November 1874 bis 1. November 1877 in Berliner Universitätspoliklinik für Ohrenkranke untersuchten und behandelten Kranken, nebst Bemerkungen zur praktischen Ohrenheilkunde. *Arch. Ohrenheilk.*, vol. 14, p. 210.

1881. Casuistische Beiträge zur Bedeutung usw. der Exostosen des äusseren Gehörganges. *Arch. Ohrenheilk.*, vol. 17, pp. 246-257.

MANASSE, P.

1908. Über Exostosen am Porus acusticus internus. *Verh. Deutsch. Otol. Ges.*, pp. 185-188. Jena.

1912. Die Otitis chronica metaplastica der menschlichen Labyrinthkapsel. Die Ohrenheilkunde und ihre Grenzgebiete. Wiesbaden.

MANASSE, P., GRÜNBERG, K., and LANGE, W.

1917. *Handbuch der pathologischen Anatomie des menschlichen Ohres*. Wiesbaden.

MARX, HERMANN

1926. Die Geschwülste des Ohres. *Handb. Spez. Path. Anat. und Histol.*, vol. 12 (Gehörorgang), p. 500 et seq. Berlin.

MASINI, O.

1882. Contributo alla patogenesi dei tumori ossei del condotto uditivo esterno. *Imparziale*, vol. 22, pp. 615-619.

MATHEWSON, A.

1876. A case of exostosis of the external auditory meatus drilled out by "dental engine". *Rep. Congr. Intern. Otol. Soc.*, pp. 86-95.

MAYER, O.

1923. Bericht über die Ergebnisse weitere Untersuchungen zur Otosklerosefrage. *Kongressber. Zeitschr. Hals-, Nasen-, und Ohrenheilk.*, vol. 6, p. 280.

1924. Ausgedehnte Exostosen und Hyperostosenbildung an der hinteren Pyramidenfläche. *Monatsschr. Ohrenheilk.*, vol. 58, p. 385.

MCKENZIE, DAN

1920. *Disease of the throat, nose and ear*. pp. 457-458. London.

MEYER, A. B., and JABLONOWSKI, J.

1901. 24 Menschenschädel von der Oster Insel. *Abh. and Ber. K. Zool. and Anthr.-Ethn. Mus.*, vol. 9, no. 4, 108 pp. Dresden.

MICHAILOWSKIJ, S.

1924. Exostosis des äusseren Gehörganges. Ukrainiskij Medicijnij Věstnik. Nos. 3, 4.

1926. Zwei Fälle von Exostosen des äusseren Gehörganges. Žurnal usnych nosovyh i gorlovyh boleznej, vol. 3, no. 12.

MIOT, D. C.

1871. Des rétrécissement du conduit auditif externe. Gaz. Hop., vol. 44, nos. 95-98.

MÖLLER-HOLST, GUNNAR

1932. Der äussere knöcherne Gehörgang südamerikanischer Schädel. Pt. 3 of Ergebnisse einer Forschungsreise nach Chile-Bolivien. Anthr. Inst. Univ. Kiel. Stuttgart.

MOODIE, R. L.

1929. Deafness among ancient California Indians. Bull. So. California Acad. Sci., vol. 28, pp. 46-49.

1930. Deafness in ancient times. Sci. Amer., vol. 142, p. 229.

1931. Roentgenologic studies of Egyptian and Peruvian mummies. Mem. Anthr., Field Mus., pp. 32-33.

MOORE, W. O.

1900. Exostoses of the external auditory canal. Post-Graduate, vol. 15, p. 785. New York.

MOOS, S.

1871. Symmetrical formations of exostosis in both external auditory canals of man. Arch. Ophth. and Otol., vol. 2, no. 1, pp. 136-138.

MOOS, S., and STEINBRÜGGE, H.

1881. Hyperostosen und Exostosenbild usw. Zeitschr. Ohrenheilk. Krankh. Luftw., vol. 11, pp. 48-51.

MOURE, E. J.

1896. Des ostéomes du conduit auditif et de leur traitement. Rev. Hebd. Laryng., etc., vol. 16, pp. 65-69.

MUNCASTER, S. B.

1891-2. Removal of exostosis from external meatus of left ear. Ophth. Rec., vol. 1, p. 386. Nashville.

NÉLATON, AUGUSTE

1869. Éléments de pathologie chirurgicale. 2me éd., vol. 2, p. 478.

NEUMANN

1889. Über die Knochenschwülste des Gehörganges. Mitth. Ver. Ärzt. Steiermark, 1888, vol. 25, p. 114. Graz.

NOLTENIUS

1890. Eine gestielte Exostose des Gehörganges. Monatsschr. Ohrenheilk., vol. 24, p. 259.

NOQUET

1899. Quelques considérations sur les exostoses du conduit auditif externe. Arch. Intern. Laryng., etc., vol. 12, pp. 267-269.

OCKEL, GLAMA, and WREDEN

1863. Bericht über die Ohrenkrankennahme in der Maximiliansheilanstalt in St. Petersburg, 1858-1861. St. Petersburg Med. Zeitschr., no. 9, pp. 129-172. Abstracted in Arch. Ohrenheilk., vol. 2, p. 164. 1864.

OETTEKING, BRUNO

1930. Craniology of the North Pacific Coast. Jesup North Pacific Expedition, vol. 11, pt. 1.

OSTMANN, P.

1893. Über das Abhängigkeitsverhältnis der Form des äusseren Gehörganges von der Schädelform. *Monatsschr. Ohrenheilk. und Laryngo-Rhin.*, vol. 27.
1894. Beiträge zu dem Vorkommen von Exostosen des äusseren knöchernen Gehörganges bei den verschiedenen Völkerrassen. *Monatsschr. Hals- Nasen- und Ohrenheilk.*, vol. 28, pp. 237, 270 and 302.

POLITZER, ADAM

1893. *Lehrbuch der Ohrenkrankheiten*, 3d. ed., p. 179. Stuttgart. (1st ed. 1878-82; 2d ed. 1887; translated into English, 1883, 1884, Philadelphia; 4th ed., London, 1902.)
1897. Über hanfkomgrosse, symmetrische Exostosen am inneren Ende des Gehörganges. *Monatsschr. Ohrenheilk.*, vol. 31, p. 211.

POOLEY, T. R.

1889. The operative treatment of a case of hyperostoses of the external auditory canal. *Trans. Med. Soc.*, pp. 241-249. New York, Philadelphia. Also in *New York Med. Journ.*, vol. 49, pp. 268-270, 1889.

PRITCHARD, U.

1891. Bony growths in the meatus and their removal. *Arch. Otol.*, vol. 20, pp. 45-51. Also translated in *Zeitschr. Ohrenheilk.*, vol. 22, pp. 114-120, 1891.

RANKE, J.

1900. Über altperuanische Schädel von Ancon und Pachacamac. München.

RAU, WILHELM

1856. *Lehrbuch der Ohrenheilkunde*, p. 194. Berlin.

RIBBERT, H.

1928. *Lehrbuch der allgemeinen Pathologie und der pathologischen Anatomie*. Leipzig.

ROOSA, D. B. ST. JOHN

1866. On bony growths in the meatus auditorius externus. *New York Med. Journ.*, vol. 2, pp. 424-429.
1891. A case of exostosis of the external auditory canal; removal; considerable improvement in hearing power. *Trans. Amer. Otol. Soc.*, vol. 5, pp. 331-339. New Bedford. Also in *Boston Med. and Surg. Journ.*, vol. 127, p. 470, 1892.

RUSSELL, FRANK

1900. Studies in cranial variation. *Amer. Nat.*, vol. 34, no. 405, pp. 737-745.

RUTTEN

1896. Exotose du conduit auditif droit; ablation au moyen de la gouge; guérison. *Bull. Soc. Belge Otol. et Laryng.*, vol. 1, p. 15. Translated abstract in *Arch. Otol.*, vol. 28, p. 462, 1899.

SABROUX, H.

1901. Exostoses du conduit auditif. *Thèse Inaug.*, 55 pp. Bordeaux.

SCHLOMKA, J. G. H.

1891. Exostosen im äusseren Gehörgang. *Inaug.-Diss.*, Halle.

SCHÜLLER, A.

1928. Typen von Schädelhyperostosen. *Demonstration in der Wiener Röntgen-Ges. Wiener Med. Wochenschr.*, no. 40.

SCHUMACHER, H.

1915. Eine frei gewordene Exostose im Bereiche des knöchernen Gehörganges mit häutigem Stiele. *Monatsschr. Ohrenheilk.*, vol. 49, pp. 14-17.

SCHWARTZE, H.

1878. *Pathologische Anatomie des Ohres*, p. 40. Berlin.

- 1863-1881. Praktische Beiträge zur Ohrenheilkunde. Statistische Berichte aus der Poliklinik für Ohrenheilkunde in Halle an der Saale auf die Jahre 1863-1881. *Arch. Ohrenheilk.*, vol. 1, p. 221; vol. 2, p. 100; vol. 3, p. 22; vol. 4, p. 15; vol. 5, p. 193; vol. 6, p. 200; vol. 16, p. 68 (veröffentlicht von H. Hessler); vol. 17, p. 40 (von demselben); vol. 18, p. 284 (von Christinneck).

1885. Die chirurgischen Krankheiten des Ohres.

SELIGMANN

1864. Über Exostosen an Peruanerschädeln. *Sitzungsber. Kais. Akad. Wiss. Wien*, p. 55; also in *Arch. Anthropol.*, vol. 4, pp. 147-148. (*Verh. Sekt. Anthropol. and Ethnol.*), 1870-71.

SHEILD, A. M.

1888. Aural exostosis removed by means of incision of the cartilaginous canal, and the application of the chisel. *Lancet*, vol. 2, p. 819.

STEINBRÜGGE, H.

1891. Die pathologische Anatomie des Gehörorganes. *In Orth, J., Lehrbuch der speciellen pathologischen Anatomie*, pt. 6, pp. 13-15.

STEWART, W. R. H.

1901. Rapid growth of an aural exostosis. *British Med. Journ.*, June 1.

STONE

1887. Ivory exostosis removed from external auditory meatus. *Liverpool Med. Chir. Journ.*, ser. 3, vol. 7, pp. 443-448.

STORY, J. B.

1887. Exostosis in the auditory meatus. *Dublin Journ. Med.*, vol. 83, pp. 45-47.

STUDLEY, CORDELIA A.

1881. Notes upon human remains from caves in Coahuila. 14th Ann. Rep. Peabody Mus., p. 233 et seq. Cambridge.

SZENES, S.

1904. Osteoma liberum meatus auditorii externi dextri. *Arch. Ohren-, Nasen- und Kehlkopfheilk.*, vol. 64, p. 7.

TAYLOR, S. J.

1894. Removal of an aural exostosis by the chisel after detachment of the auricle. *British Med. Journ.*, vol. 2, p. 867, October 20.

TEN KATE, H.

1896. Sur quelques points d'ostéologie ethnique imparfaitement connus. *Rev. Mus. La Plata*, vol. 7, pp. 264-265.

TILLEY, H.

1902. Large hyperostosis removed from left auditory meatus. *Trans. Otol. Soc. Unit. King.*, vol. 4, pp. 23-27. London.

TOD, H.

1909. Exostosis of right external meatus in a boy aged 10. *Proc. Roy. Soc. Med.*, vol. 3, Otol. Sect., pp. 76-78.

TOMKA, S.

1899. Exostosis of the outer auditory passage. *Orvosi Hetil.*, vol. 43, pp. 655-657. Budapest.

TOYNBEE, J.

1849. On osseous tumours growing from the walls of the meatus externus, and on the enlargement of the walls themselves; with cases. *Prov. Med. and Surg. Journ.*, vol. 14, pp. 533-537.
1860. *Diseases of the Ear*. Philadelphia.

TRIQUET, E. H.

1857. *Traité pratique des maladies des oreilles*. Paris.
1866. *Leçons cliniques sur les maladies de l'oreille*, vol. 2, pp. 280-281. Paris.

TURNER, WILLIAM

1879. On exostoses within the external auditory meatus. *Journ. Anat. and Physiol.*, vol. 13, pp. 200-203.

URBANTSCHITSCH, VICTOR

1901. *Lehrbuch der Ohrenheilkunde*. 4th ed., Berlin and Wien.

VIRCHOW, R.

1864. *Die Krankhaften Geschwülste*, vol. 2, p. 68. Berlin.
1875. Über einige Merkmale niederer Menschenrassen am Schädel. *Phys. Abh. Kön. Preussischen Akad. Wiss.*, p. 99.
1885. Über krankhaft veränderte Knochen alter Peruaner. *Sitzungsber. Kön. Preussischen Akad. Wiss.*, pt. 2, pp. 1129-1140.
1889. Beiträge zur Craniologie der Insulaner von der Westküste Nordamerikas. *Zeitschr. Ethn.*, vol. 21, pp. 391, 395, 401.
1892. *Crania ethnica americana*. Berlin.
1893. Über Exostosen des Meatus auditorius externus. *Berlin Klin. Wochenschr.*, vol. 30, pp. 635-637.

VON LUSCHAN, F.

1896. Defekte des Os tympanicum an künstlich deformierten Schädeln von Peruanern. *Verh. Berlin Ges. Anthr.*, p. 69.
1904. Über ein Os supratympanicum beim Menschen. *Zeitschr. Ethn.*, vol. 37, p. 625.

VON ROKITANSKY, C. F.

1864. *Handbuch der pathologischen Anatomie*, vol. 3.

VON ROSEN, E.

1919. *En förgängen värld*. Stockholm.

VON TROELTSCH

1873. *Lehrbuch der Ohrenheilkunde*. 5th ed., p. 124. (1st ed. 1862, 7th ed. 1881).

VON TSCHUDI, J. J.

1844. Über die Ureinwohner von Peru. *Müller's Archiv*, pp. 98-109.

WALDEYER, W.

1909. Der Processus retromastoideus. *Abh. Kön. Preussischen Akad. Wiss.*

WEBER, C. O.

1856. *Die Exostosen und Enchondrome*. Bonn.

WELCKER, H.

1864. Über knöcherne Verengerung und Verschliessung des äusseren Gehörganges. *Arch. Ohrenheilk.*, vol. 1, pp. 163-174.

WEST, C. E.

1912. Meatal exostosis, and patient after removal. *Journ. Laryng.*, vol. 27, p. 39.

WHITNEY, W. F.

1886. Notes on the anomalies, injuries and diseases of the bones of the native races of North America. 18th Ann. Rep. Peabody Mus. Cambridge.

WILDE, W. R.

1853. Practical observations on aural surgery and nature and treatment of diseases of the ear. Philadelphia.

WYMAN, JEFFRIES

1874. Report on a collection of Peruvian Crania. 7th Ann. Rep. Peabody Mus., p. 15. Cambridge.

ZSCHOKKE, E.

1845. Über eine merkwürdige, bisher unbekannte veränderung an Menschenknochen aus Peru. Inaug.-Diss. Würzburg.

ZUCKERKANDL, EMIL

1873. Zur entwicklung des äusseren Gehörganges. Monatsschr. Ohrenheilk., vol. 7, pp. 30-34.
1874. Über oxycephale und akrocephale Cranien. Mitt. Anthr. Ges. Wien, vol. 4, p. 153.

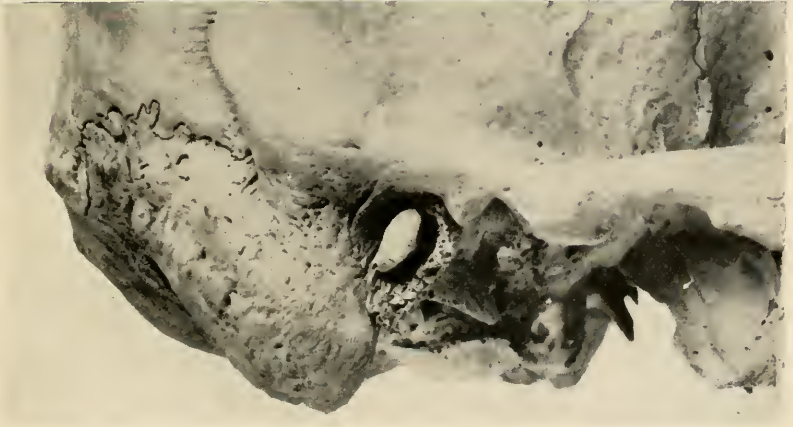
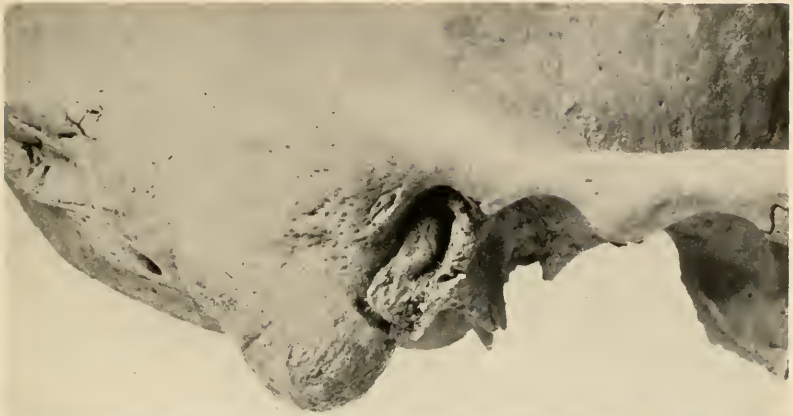

THREE PRE-COLUMBIAN SKULLS FROM PERU, EACH WITH A LARGE POSTERIOR EAR EXOSTOSIS, WITH VARIOUS BASE ATTACHMENTS



THREE PRE-COLUMBIAN SKULLS FROM PERU, WITH IRREGULAR POSTERIOR AND ANTERIOR (OR A-S) EAR EXOSTOSES



THREE PROBABLY PRE-COLUMBIAN INDIAN SKULLS, UPPER FROM VIRGINIA, LOWER TWO PERU, WITH DOUBLE (POSTERIOR AND ANTERIOR) EAR EXOSTOSES, OF VARIOUS SHAPES

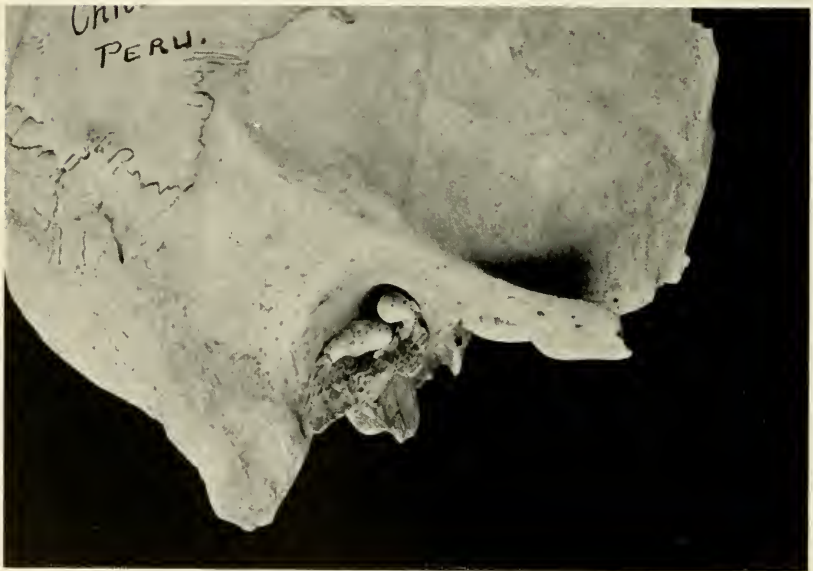
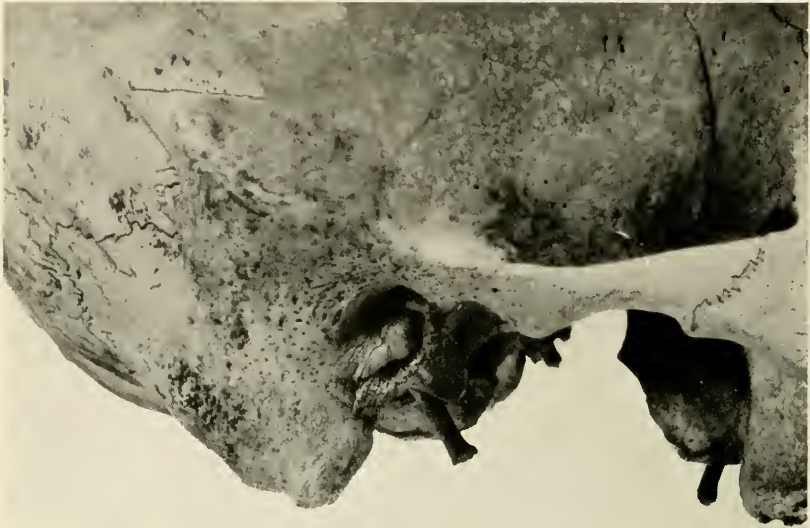

TWO PREHISTORIC SKULLS FROM PERU WITH EAR EXOSTOSES

UPPER: A VERY LARGE POSTERIOR (OR P-I) WITH A SMALL ANTERO-SUPERIOR GROWTH

LOWER: TWO LARGE GROWTHS, POSTERIOR AND ANTERIOR, WITH SECONDARY SMALL GROWTHS ANTERIORLY



UPPER: PRE-COLUMBIAN INDIAN SKULL, PERU, WITH TRIPLE EAR EXOSTOSIS

LOWER: THE SAME, WITH A 5 MM-HIGH EXOSTOSIS OUTSIDE ABOVE THE MEATUS, OF SEPARATE ORIGIN AND SIGNIFICANCE. SMALL INTRAMEATAL EXOSTOSIS IN EACH EAR

INDEX OF AUTHORS

- Alderton, H. A., 18, 60
 Alexander, G., 10, 14, 17, 18, 20, 23, 24,
 44, 45, 49, 50, 53, 54, 55, 56, 58, 59,
 64, 70, 74
 Autenrieth, J. H. F., 1, 18, 46
 Ayres, S. C., 18, 34, 40
 "B", Dr. "L. of Hamburg," 67
 Bachauer, J., 9, 14, 17, 49
 Ballenger, W. L., 44, 52, 55, 60, 61,
 62, 63, 67
 Bauer, J., 44
 Bezold, F., 7, 13, 23, 24, 27, 30, 31, 43,
 50, 55, 57, 61, 63, 66, 74
 Blake, C. J., 3, 4, 6, 8, 13, 14, 22, 30, 31,
 34, 35, 39, 49, 55, 56, 66
 Bonnafont, J. P., 2, 18, 27
 Boyer, 55, 56
 Braunberger, E., 17, 24, 27, 30, 41, 48,
 55
 Brindel, 23
 Burkhardt-Merian, A., 17
 Bürkner, K., 17, 82, 83
 Burton, F. A., 9, 10, 14, 20, 34, 49, 52,
 54, 55, 64, 74
 Carr, L., 4, 14
 Cassells, J. P., 18, 42, 44, 66
 Cheatle, A. H., 18
 Cocks, D. C., 46, 66
 Cook, 66
 Dahlström, W., 1, 34, 37, 47, 66
 Dalby, W. B., 18, 40, 41, 50, 59, 62
 Darnach, 54
 Davis, J. B., 3, 14, 22
 Delstanche, C. (fils), 17, 18, 27, 30, 31,
 34, 40, 46, 50, 53, 55, 59, 61, 62
 De Rossi, E., 24
 Désarènes (*see* Garrigou-Désarènes)
 Dorsey, G., 7, 14
 Duplay, 61
 Dupuytren, 50
 Edward, 24
 Erhardt, J., 24, 61
 Eulenstein, 46
 Ferreri, G., 18, 23, 24, 30, 34, 44, 47,
 49
 Field, G. P., 18, 23, 53, 63, 65
 Flower, W. H., 4, 14, 22
 Fournier, 61
 Fürst, 51
 Garrigou-Désarènes, 18, 23, 49
 Goldstein, M. A., 18, 34, 49, 50, 63, 69
 Gray, A. A., 24, 37, 44, 47, 54, 55, 63
 Green, J. O., 18, 23, 51, 63
 Gruber, J., 17, 52, 61, 74
 Hartmann, A., 5, 13, 18, 34, 42, 44,
 52, 55, 56
 Hedinger, A., 17, 18, 46, 48, 49, 59, 61,
 62, 66
 Heiman, T. H., 18, 51, 59, 62, 65, 67,
 73
 Hooton, E. A., 71
 Hovell, T. M., 18
 Jablonowski, 8
 Jackson, G., 13, 14, 18, 43, 62, 65
 Jacquemart, A., 18, 34, 59, 61, 62, 66,
 67
 Jones, F. Wood, 79
 Karewski, 23
 Kaufmann, E., 44, 45
 Kerrison, P. D., 31, 34
 Kessel, O. G., 1, 13, 18, 23, 24, 27, 34,
 39, 40, 41, 42, 44, 47, 49, 51, 55, 56,
 59, 61, 62, 63, 66, 67
 Kirchner, W., 55, 56
 Klotz, 66
 Knapp, 74
 Körner, O., 8, 13, 24, 25, 27, 30, 31, 34,
 40, 41, 43, 51, 55, 56, 57, 63, 65, 67
 Krakauer, 23, 61, 74
 Krämer, W., 2
 Kuhn, 46, 62
 Lake, R., 18, 24, 43, 49, 52, 65
 Law, E., 18, 58, 65
 Lebourg, 8, 14, 49, 51, 75
 Le Double, A. F., 8, 14, 49, 50, 51, 75
 Lucae, A., 17
 Manasse, P., 44
 Martin, 13
 Marx, H., 24, 34, 44, 45, 47, 48
 Masini, O., 18, 50, 53, 55, 56, 62

- Mathewson, A., 18
 Mayer, O., 48, 64
 McKenzie, D., 44, 63, 65
 Menière, 61
 Meyer, A. B., 8
 Michailowskij, S., 62, 63
 Möller-Holst, G., 10, 13, 14, 17, 20,
 35, 37, 40, 41, 44, 45, 47, 50, 51, 54,
 56, 57, 58, 59, 64, 65, 67, 70, 73, 74
 Moodie, R. L., 10, 20, 57
 Moore, W. O., 8, 18, 55, 56, 65
 Moos, S., 34, 48, 51, 62
 Nélaton, A., 46, 53
 Newark, 17
 Noltenius, 66
 Noquet, 18, 41, 60, 61
 Norrell, 24
 Oettinger, B., 10, 14, 20, 22, 34, 44,
 47, 70
 Ostmann, P., 5, 6, 13, 14, 22, 34, 44,
 53, 69, 74, 79
 Patterson, 66
 Politzer, A., 5, 13, 18, 47, 48, 49, 52,
 55, 60, 61, 62, 63, 66, 67
 Pritchard, U., 42, 60, 62, 66
 Rafin, 74
 Ranke, J., 8, 9, 14, 48
 Rau, W., 59, 62
 Reuchard, 24
 Roosa, D. B. St. J., 1, 18, 47, 48, 50, 59,
 61, 62, 63
 Rougier, 74
 Russell, F., 8, 14, 16, 22, 37, 53, 69,
 70
 Sabroux, H., 17, 18, 27, 30, 31, 34,
 37, 39, 41, 43, 48, 50, 60, 61, 62, 66,
 67, 74
 Schlomka, J. G. H., 17, 18, 27, 30, 34,
 39, 40, 47, 63, 67
 Schmaltz, 74
 Schwartz, H., 17, 46, 47, 55, 61
 Seligmann, 3, 5, 14, 66
 Sexton, 24
 Siebenmann, 24, 43, 50, 55, 57, 61
 Stein, 44
 Steinbrugge, H., 1, 48
 Stewart, W. R. H., 18, 41
 Studley, C. A., 5, 14, 22, 70
 Taylor, S. J., 18
 Ten Kate, H., 7, 14, 69, 70
 Tod, H., 18, 23, 47, 57, 60, 65, 66
 Toynbee, J., 1, 2, 3, 13, 16, 18, 33, 41,
 42, 46, 58, 59, 62, 74
 Triquet, E. H., 61
 Turner, W., 4, 14, 49, 69
 Urbantschitsch, V., 18, 41
 Velpeaux, 8, 50
 Virchow, R., 3, 5, 14, 34, 42, 44, 46,
 47, 48, 50, 51, 59, 63, 66, 69, 70, 74
 Von Luschan, F., 7, 69
 Von Rokitsansky, C. F., 1, 2
 Von Troeltsch, 2, 24, 27, 30, 31, 34,
 39, 41, 42, 48, 57, 59, 61
 Wagenhäuser, 67
 Weber, C. O., 47
 Weil, 24
 Welcker, H., 3, 14, 18, 22
 West, C. E., 18, 23
 Whitney, W. F., 24, 27, 37, 48, 49,
 68, 69, 75
 Wilde, W. R., 62
 Wyman, J., 3, 14, 37
 Zschokke, E., 3
 Zuckerkandl, Emil, 44

SMITHSONIAN MISCELLANEOUS COLLECTIONS

VOLUME 93, NUMBER 7

THE CHRISTIANSEN LIGHT FILTER: ITS ADVANTAGES AND LIMITATIONS

(WITH TWO PLATES)

BY

E. D. McALISTER

Division of Radiation and Organisms, Smithsonian Institution



(PUBLICATION 3297)

CITY OF WASHINGTON

PUBLISHED BY THE SMITHSONIAN INSTITUTION

APRIL 2, 1935

The Lord Baltimore Press
BALTIMORE, MD., U. S. A.

THE CHRISTIANSEN LIGHT FILTER: ITS ADVANTAGES AND LIMITATIONS

BY E. D. McALISTER

Division of Radiation and Organisms, Smithsonian Institution

(WITH 2 PLATES)

INTRODUCTION

Since the Christiansen light filter is little known in this country, it is believed that a brief description of the filter and a discussion of its possibilities may be useful. The object of the present paper is threefold: 1, to report an improvement in the construction of the filter, which allows its use in an intense beam of light; 2, to discuss the advantages and limitations of these filters for general usage; and 3, to give some "practical suggestions" concerning the construction of these filters. The improvement mentioned has arisen from a need (in our laboratory) for an extensive beam of reasonably monochromatic light intense enough to produce an easily measured amount of photosynthesis in a higher plant. The second and third purposes of the paper are to answer numerous inquiries the writer has received during the past year.

REVIEW OF LITERATURE

In 1884 C. Christiansen discovered that a mass of glass particles immersed in a liquid transmitted freely that color for which the liquid and glass particles had the same refractive index. He pointed out in two papers (1884, 1885) that any desired color could be obtained and that a color complementary to the one directly transmitted was seen at oblique angles. He also showed that the wave length of the transmitted ray decreased rapidly with an increase in temperature. After a paper with comments and improvements by Lord Rayleigh in 1885, the subject lay dormant for nearly 50 years with the exception of a descriptive paragraph in all editions of R. W. Wood's "Physical Optics." In a series of three papers F. Weigert and collaborators (1927, 1929, 1930) show the necessity of accurately controlling the temperature of the filters and the advantage of a refined optical system, and also describe a single filter that transmits red light when at 18° C.

and blue light when at 50° C. Konrad von Fragstein, in 1932 and 1933, describes a filter for the near ultraviolet. One filter covers the range from 3000 Å to 3700 Å by temperature variation. E. Knudsen, in 1934, discusses all the various ways of making these filters and points out the possibility of making a filter of particles of low-dispersion glass in combination with particles of high-dispersion glass fused together, both having the same index of refraction for the desired wave length. He has made such a filter but gives no details of its performance.

DESCRIPTION OF THE FILTER AND DISCUSSION OF ITS ACTION

In their commonest form these filters are made up of a solid pack of optical glass particles (0.5 to 2 mm in size) in a glass cell, with the spaces between filled with a liquid having the same index of refraction as the glass for the wave length desired. (The present paper is not concerned with the various emulsions and colloidal preparations exhibiting "Christiansen colors." Readers interested in these are referred to Knudsen, 1934.) Figure 1 gives the curves—index of refraction plotted against wave length—for a low-dispersion (borosilicate) crown glass and a suitable liquid—10 percent (by volume) carbon disulphide in benzene at 20° C. (both anhydrous). Remembering the laws of refraction and reflection at an interface, we see that for the wave length where both liquid and glass have the same index of refraction, the filter acts as a solid plate, and the rays of this wave length are transmitted without deviation or reflection loss within the filter. All other rays of shorter and longer wave lengths are deviated and reflected in an amount dependent upon the difference in the indices at the interfaces—glass to liquid and liquid to glass. Examining these curves in figure 1 more closely, we see that they depart from each other more rapidly on the blue side of the crossing than they do on the red side. This is typical of most suitable glasses and liquids. This shows that the filters will have a sharper blue "cut-off" than the red. Also a filter made for blue light will transmit purer colors than one made for longer wave lengths. These two characteristics are evident in the curves shown in figures 2 and 3. Obviously, it is desirable to use a glass of the lowest possible dispersion in combination with a liquid having the highest possible dispersion.

The refractive index of a liquid changes rapidly with its temperature in comparison with that of the glass. Hence the color transmitted by the filter will vary with its temperature. Thus to maintain a given color, the temperature of the filter must be held constant. For use

with light of low intensity, such as in visual work, a carefully thermostated water bath is sufficient. For use with intense light, such as direct sunlight, other more direct means of cooling (discussed below) are necessary. Weigert (1929), making use of this temperature co-

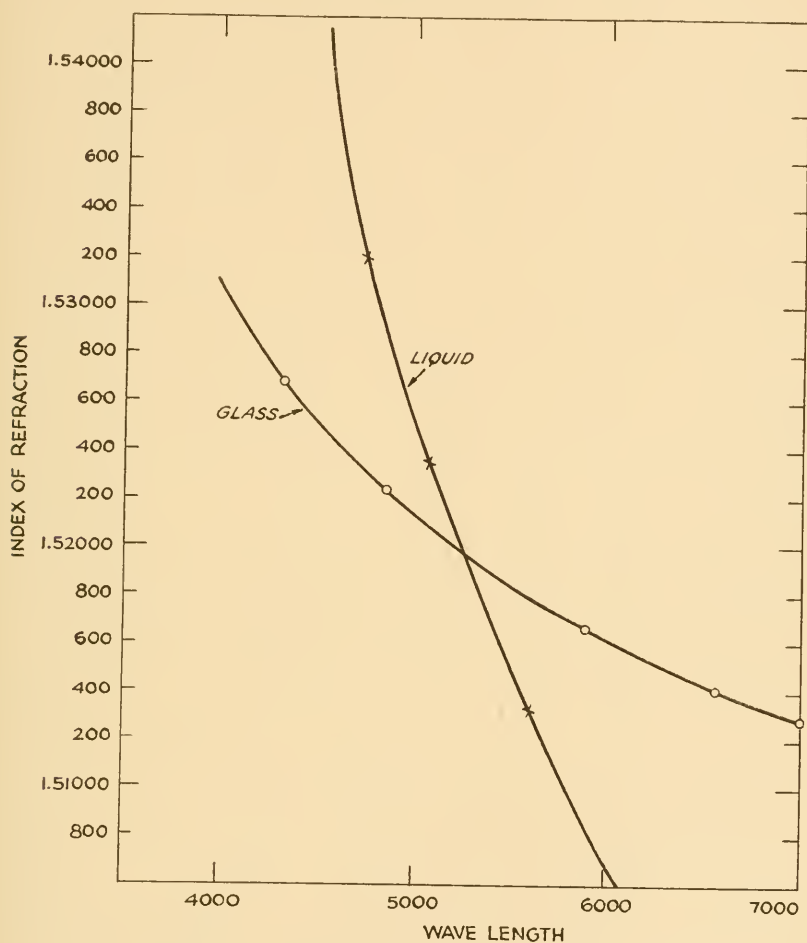

FIG. 1.—Index of refraction curves of the components of a filter.

efficient, constructed an ingenious filter using methyl benzoate with crown glass particles. This filter transmits red light when at 18° C. and blue at 50° C.

These filters are not used like the ordinary colored-glass ones. The "undesired" colors are not absorbed as in the case of colored glass, but are scattered symmetrically in a halo about the center line through

the filter. The angular position of a given "undesired" color about the axis of the filter depends upon two factors: 1, the difference in the indices of the liquid and glass for that wave length; and 2, the

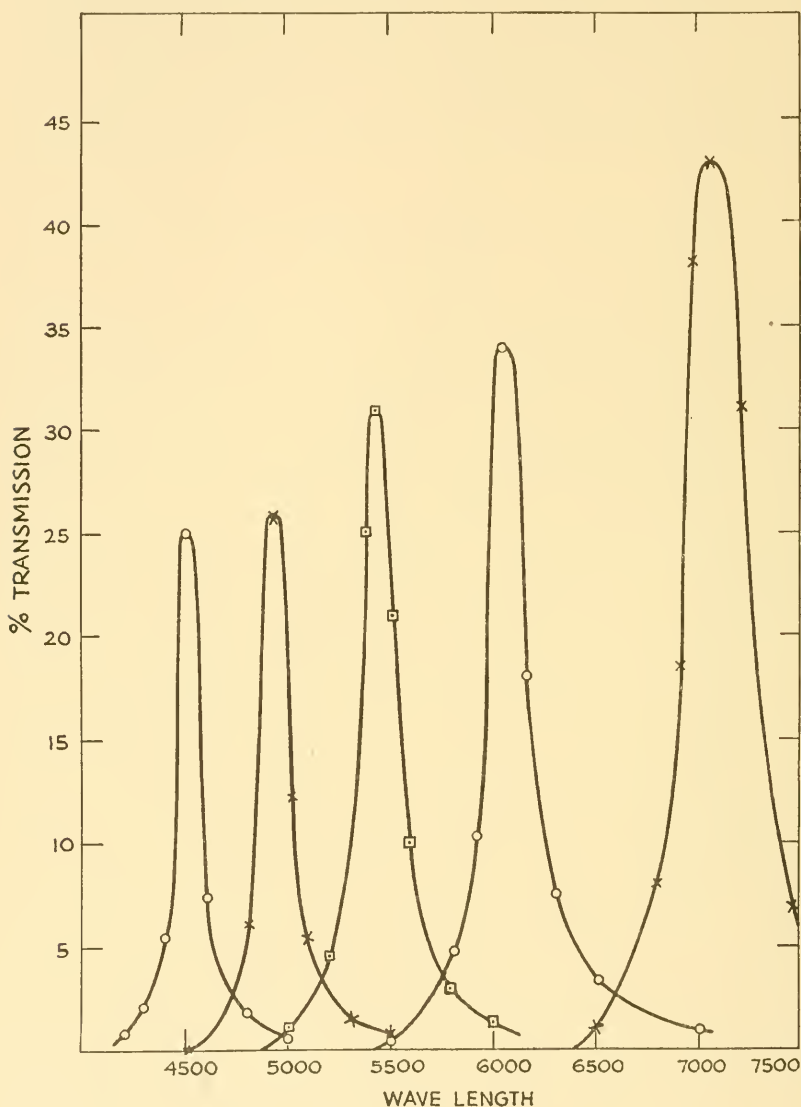

FIG. 2.—Transmission curves of a set of five filters at 20° C.

number of interfaces through which the beam passes (i. e., particle size and thickness of the filter). Also, since the interfaces are oriented in a random or probability manner, there exists only a "most proba-

ble" angle for a given "undesired" color and this color is in evidence in varying amounts at all angular positions about the axis of the filter. Some means of intercepting these "undesired" wave lengths is necessary. The simplest means is to use an optical system consisting of two lenses with the filter placed between them in parallel light. In this case the "undesired" wave lengths are cut out by a diaphragm placed at the image of the source of light. It is imperative that the opening in this diaphragm should conform with the shape of the source of light. If a filament is the source, the opening in the diaphragm should be cut to conform to the shape and size of the image of the filament. If this is not done, the maximum purity of color is not attained. Obviously, the purity of the color obtained increases with an increase in focal length or a decrease in numerical aperture of the optical system used. (See, for instance, von Fragstein, 1933, pp. 33 and 34.) Thus it is necessary to measure the transmission of the filter with the particular optical set-up to be used. Another way of using the filter is in parallel light—direct sunlight, for instance—employing a series of diaphragms to intercept the halo of "undesired" wave lengths. In this case it is necessary to place the filter at a considerable distance from the observer, since the purity of color obtained increases with distance from the filter.

Owing to the fact that the "undesired" colors are not absorbed but are scattered at various angles about its axis, the Christiansen filter cannot be used in any optical system where sharp images are desired. For instance, it cannot be used before the lens of a camera in photography. The only way it could be used in this respect is with its own optical system to illuminate the object (necessarily a small one) to be photographed.

Figure 2 shows the transmission characteristics of a set of five filters at 20° C. They are all made of borosilicate crown glass particles (1 to 2 mm in size) immersed in mixtures of carbon disulphide and benzene. The blue filter has about 4 percent (by volume) carbon disulphide, the red one 20 percent, and the others have percentages between these limits. These filters are 50 mm in diameter, 18 mm thick, and the windows are fused on optical flats. Two of them are shown in plate I. The transmission curves (fig. 2) were measured with the filters in parallel light between two 20-cm focal length lenses. A double monochromator and vacuum thermocouple were used to make the measurements. This purity of color is obtained only in the image of the filament used as a source.

A battery of 10 such filters ranging from ultraviolet to infrared, each selecting a spectral region about 150 Å wide (at half maximum),

was used by Messrs. Abbot, Stebbins, and Aldrich on Mount Wilson in 1934 to measure the distribution of radiation in the spectra of stars at the Conde focus of the 100-inch reflector. The filters were mounted within a constant-temperature box upon a squirrel-cage device, so as to be successively introduced into a collimated beam. The selected ray was brought to focus with a 19-cm focus lens. All this part of the experiment worked well, and owing to the short-focus objective lens

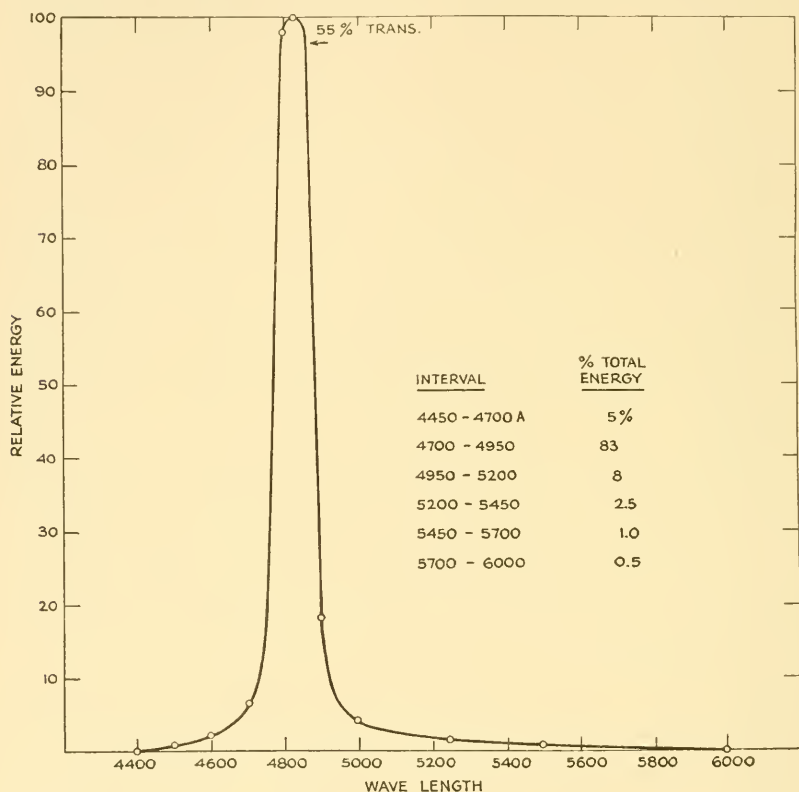
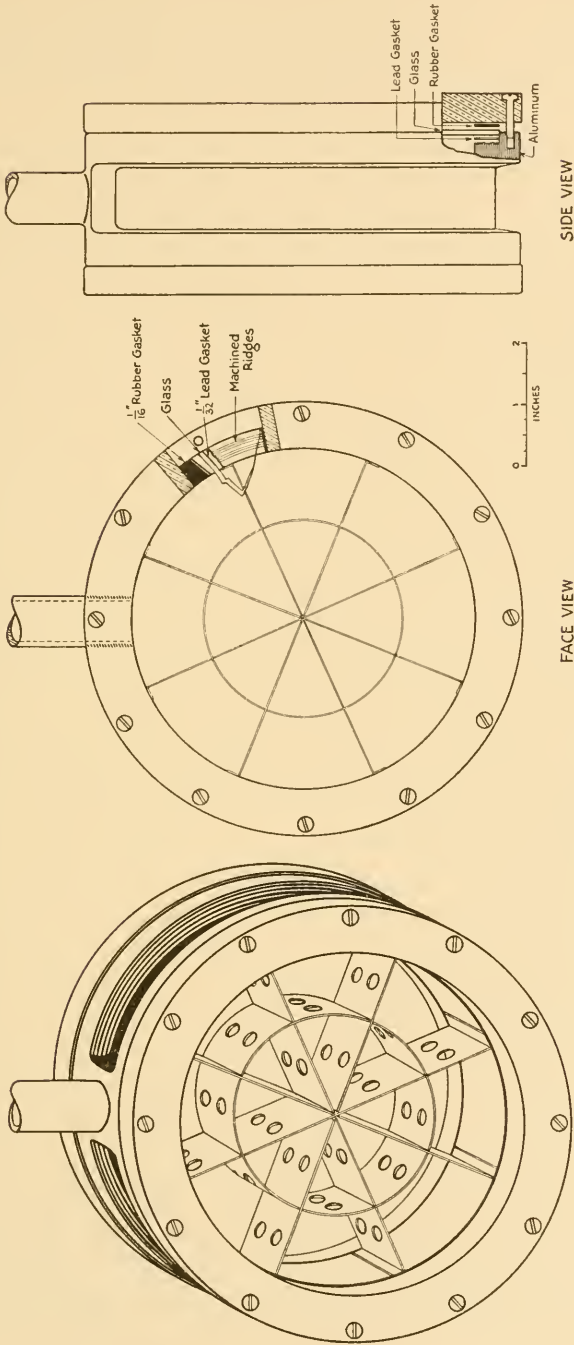

FIG. 3.—Energy transmission curve for a 6-inch diameter filter equipped with vanes.

the quality of the atmospheric seeing was immaterial. Unfortunately, the sharp peak of the photoelectric cell sensitivity proved fatal to the success of the observations. Small traces of stray light of bluish color were so disproportionately effective as to mask real values in the ultraviolet and the red. Dr. Abbot hopes to develop a sufficiently sensitive black receiver as a substitute for the photoelectric cell in future stellar work.

Figure 3 shows the energy transmitted by a 6-inch diameter filter (described below and detailed in fig. 4), using the parallel rays of



SIDE VIEW

FACE VIEW

FIG. 4—Diagrams showing detailed construction of a 6-inch filter with vanes.

direct sunlight. The observations were made 66 feet from the filter with the filter temperature held at 20° C. This purity of color is obtained over a 6-inch circular area at that distance.

AN IMPROVEMENT THAT PERMITS THE USE OF AN INTENSE BEAM OF LIGHT

The necessity of an optical system and the disadvantage of the temperature coefficient have been pointed out in detail in previous publications. However, for any exacting use of the filter where much light energy is used there is still another trouble which proves to be very serious: when a strong beam of light is forced through the filter, some energy is absorbed, and the center reaches a higher temperature than the edges, owing to poor heat conduction. The color transmitted is no longer pure, even when the filter is in a water bath. The writer has finally overcome this difficulty by inserting aluminum vanes through the body of the filter so as to cut off the least amount of light and carry off as much heat as possible. Details of a satisfactory filter equipped with these vanes are shown in figure 4. The body of the filter is cast aluminum, machined as shown, to take the glass windows and the necessary gaskets. No cement is known to the writer that will satisfactorily withstand the benzene and carbon disulphide mixture on the inside and the water on the outside. For this reason the windows were clamped on, as shown, with a soft lead gasket ($\frac{1}{8}$ inch thick) underneath the glass. Ridges were machined on the aluminum face to press into the lead gasket and improve the seal. A $\frac{1}{16}$ -inch rubber gasket is placed between the glass window and the brass clamping ring. The vanes are of $\frac{3}{32}$ -inch aluminum assembled so that their extremities press firmly against the inner wall of the aluminum case, thus providing a path of good heat conduction from the inside of the filter to the surrounding water bath. The holes shown in the vanes allow the cell to be filled with the glass particles after it is assembled. Without these vanes, the center of this filter rose 9° C. above the temperature of the water bath when the rays from a 1,000-watt lamp were concentrated on the filter. With the vanes installed, the temperature at the center of the filter rose only 0.25° C. above that of the water bath under the same conditions.

Plate 2 figure 1, is a photograph of this filter in its water bath. The filter is filled with glass particles and a liquid (about 9 percent carbon disulphide in benzene), and gave the transmission curve shown in figure 3 under the conditions previously mentioned. Plate 2, figure 2, is a photograph of a 12 × 14-inch filter (not filled) with its water bath. When in use the water of the bath is thermostated and stirred.

Aluminum was chosen as the metal for the cell and vanes because it is least attacked by the various liquids used. The outside of the aluminum case must be carefully covered with several coats of waterproof paint.

PRACTICAL CONSIDERATIONS IN THE CONSTRUCTION AND USE OF THESE FILTERS

The Christiansen filter is little known in this country. For this reason the writer believes it will not be amiss to pass on to those interested some practical points concerning the construction of these filters and their uses. In this connection the writer is drawing on the literature cited and his own experience with these filters.

The type of cell chosen to hold the components depends upon the use to be made of the filter. For visual work and other uses where only moderate intensities are necessary, a glass cell with parallel windows fused on is suitable. If a permanent filter is desired, a small expansion chamber should be provided on the filling "neck," and after filling, the cell should be sealed off above the expansion chamber in a flame. To do this safely the expansion chamber should be packed in carbon dioxide snow. When high intensities of light are used, such as direct sunlight, the cell needs to be of the type detailed in figure 4. To be sure, a thin glass cell may be used for high intensity work, but the purity of color will be very inferior to that obtained with a metal-cased filter equipped with vanes.

The glass particles for the filter should be of the best optical quality obtainable—preferably low-dispersion borosilicate crown glass. Fused quartz is also suitable and of course necessary for ultraviolet work. However, the quartz should be free of bubbles and inclusions, as these lower the transmission of the filter and give it a muddy appearance. In preparing the glass particles, the writer has used the following procedure. If the glass or fused quartz is in large fragments, it is ground up with an iron mortar and pestle until the larger particles are 2 or 3 mm in size. This should be done with a minimum of grinding. A damp towel should be wrapped about the top of the pestle and draped over the top of the mortar to prevent the "dust" from flying. The operator should use some protection over his nostrils to avoid breathing the dust. The glass particles are graded by running them through several sizes of sieves. Before using, the particles must be carefully cleaned. This is best accomplished by boiling in chromic acid cleaning solution. The particles are then washed many times in clear water, then in distilled water, and finally dried completely. The particle size found suitable by previous workers and the writer ranges from 0.5

to 2 mm (usually graded closer—i. e., 0.5 to 1 mm, or 1 to 2 mm). A cell 15-mm thick using the 0.5 to 1 mm particles gives approximately the same results as a 30-mm cell using the 1 to 2 mm particles. With a given optical system, reducing the particle size or increasing the cell thickness gives a narrower transmission curve with lower percentage transmission at the "peak." In an "ideal" filter the glass particles would be perfectly homogeneous as to refractive index, and these particles and the liquid surrounding them would be all at exactly the same temperature. It is because these two conditions can never be realized that the percentage transmission at the "peak" decreases as the number of interfaces in the filter is increased.

In filling the cell it is best to put the liquid in first—enough to fill the cell about half full. The glass particles are then poured in slowly so that air bubbles are not carried down. It is difficult to free the cell of air bubbles after it is packed solid with the glass particles. The liquid or liquids used must be anhydrous and of the highest purity. The mixing of carbon disulphide and benzene—originally suggested by Christiansen in 1884—to obtain a liquid of any desired index of refraction (between that of pure benzene and pure carbon disulphide, of course) has been found very satisfactory by the writer in spite of its relatively high temperature coefficient. Methyl benzoate, used by Weigert (1929, 1930), in combination with crown glass particles makes a remarkably variable filter. Von Fragstein (1932, 1933) uses a mixture of 44 per cent alcohol (ethyl) and benzene with fused quartz particles for an ultraviolet filter. This filter, with suitable optics, transmits a narrow band of wave lengths in any desired part of the region 3000 Å to 3700 Å. The wave length of maximum transmission is shifted as desired in this region by temperature variation, just as in Weigert's methyl benzoate cell.

Various optical systems have been described in the literature. Weigert's (1929) autocollimator is of considerable interest as it passes the rays twice through the filter. The writer has shown that the filter can be used successfully without an optical system (other than plane mirrors and diaphragms) in direct sunlight, or, of course, in any beam of similar parallelism of rays. In using an optical system it is again emphasized that the diaphragm at the image of the source of light must conform in size and shape to this image. Any change in this diaphragm will change the transmission characteristics of the set-up. This is shown clearly by Weigert (1929, fig. 13, p. 159).

In the use of the filter for studying the wave-length effect of some photochemical phenomena it is necessary to allow for or take into account the effect of the "undesired" colors—i. e., those wave lengths

shorter and longer than the wave length of maximum transmission. In any case care must be exercised in determining the combined effect of the shape of the transmission curve of the filter, the wave length versus sensitivity curve of the phenomena under investigation, and, in the case where the energy content of the beam from the filter is measured with a photocell, the sensitivity versus wave-length response of the detector. For instance, if the energy in the beam from an ultra-violet filter is measured with a photocell that has its maximum sensitivity in the blue, considerable error may come into the final result owing to the long-wave-length "tail" on the transmission curve of these filters. (See von Fragstein, 1933, fig. 8, p. 33.)

The writer believes that these filters will be found of considerable value as a source of monochromatic light for rough visual measurements of refractive index, rotation of plane of polarization, etc., because one can set cross hairs on the wave length of maximum transmission within ± 10 angstroms. With a sealed filter and accurate temperature control this wave length of maximum transmission is sharp and reproducible.

The large filter shown in plate 2, figure 2, will be used with sunlight to irradiate a growing plant in an experiment to determine the wave-length effect of photosynthesis. At great distance it will yield a transmission curve comparable to that shown in figure 3. Two filters are to be used—one to cover the range 4000 A to 6000 A, the other from 5500 A to 8000 A. The wave length of maximum transmission is moved through these ranges by temperature variation.

The possibility of substituting a high-dispersion glass for the liquid—i. e., making the filter of a high-dispersion glass flowed around the particles of low-dispersion glass—is interesting. Knudsen (1934) has accomplished this, but gives no details. The resultant filter will have only a very small temperature coefficient, which will considerably enhance its usefulness. The writer has in his possession two suitable glasses, but has not yet had an opportunity to complete the filter.

The writer is grateful to A. N. Finn, of the United States Bureau of Standards, who has kindly furnished the borosilicate crown glass, and to L. B. Clark, of the Division of Radiation and Organisms of the Smithsonian Institution, who constructed the glass cells with fused-on optical windows.

LITERATURE CITED

CHRISTIANSEN, C.

1884. Untersuchungen über die optischen Eigenschaften von fein vertheilten Körpern. *Ann. Phys. Chem.*, vol. 23, pp. 298-306.
1885. *Idem*, vol. 24, pp. 439-446.

KNUDSEN, E.

1934. Chromatische disperse Zweiphasensysteme unter besonderer Berücksichtigung ihrer Verwendung als Lichtfilter. *Koll. Zeitschr.*, vol. 66, pp. 257-266, March.

KOHN, H., and VON FRAGSTEIN, K.

1932. Ein Christiansenfilter für ultraviolettes Strahlung. *Phys. Zeitschr.*, vol. 33, pp. 929-931.

RAYLEIGH, LORD

1885. On an improved apparatus for Christiansen's experiment. *Phil. Mag.*, vol. 20, pp. 358-360.

VON FRAGSTEIN, K.

1933. Ein Christiansenfilter für ultraviolettes Licht. *Ann. Phys.*, vol. 17, pp. 22-40.

WEIGERT, F., and STAUDE, H.

1927. Über monochromatische Farbfilter. *Zeitschr. Phys. Chem.*, vol. 130, pp. 607-615.

WEIGERT, F., STAUDE, H., and ELVEGARD, E.

1929. Über monochromatische Lichtfilter. II. *Zeitschr. Phys. Chem.*, ser. B, vol. 2, pp. 149-160.

WEIGERT, F., and SHIDEI, J.

1930. Photodichroismus und Photoanisotropie. VII. *Ibid.*, vol. 9, pp. 329-355. (See pp. 331-334.)

WOOD, R. W.

- Christiansen's experiment. In all editions of Wood's *Physical Optics*.

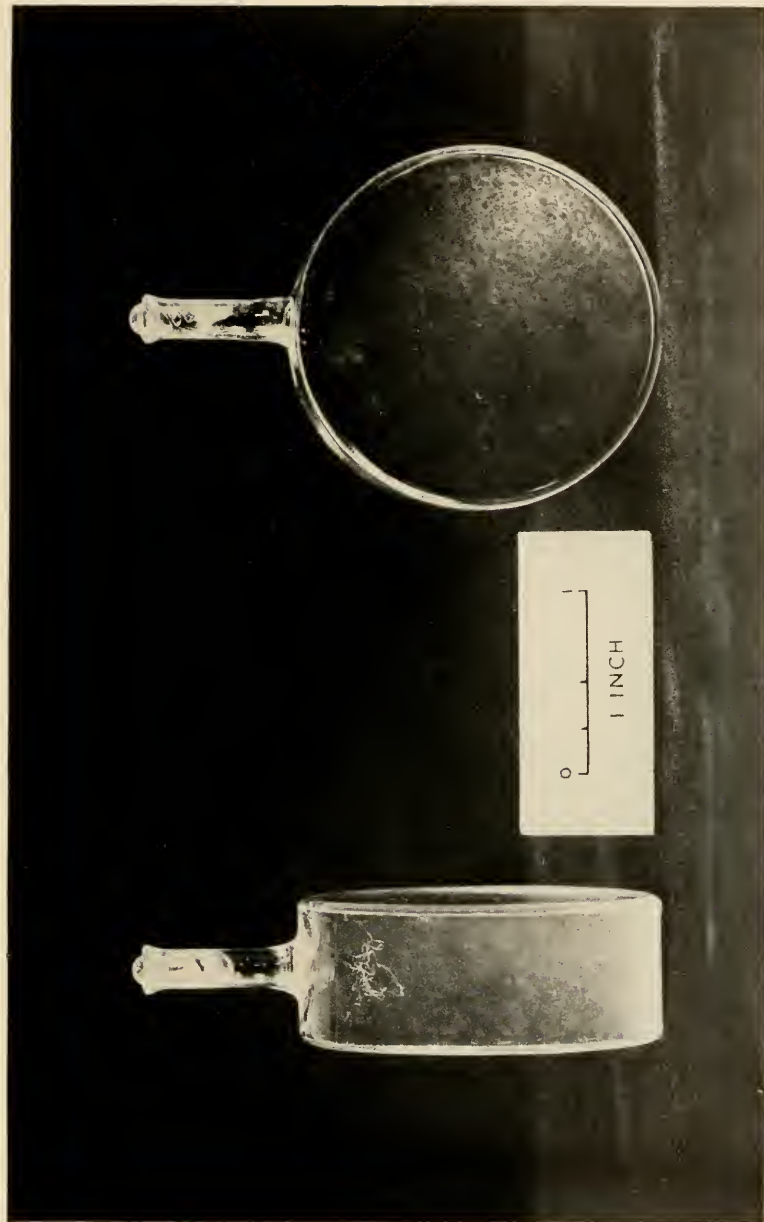

TWO-INCH FILTERS IN GLASS CELLS

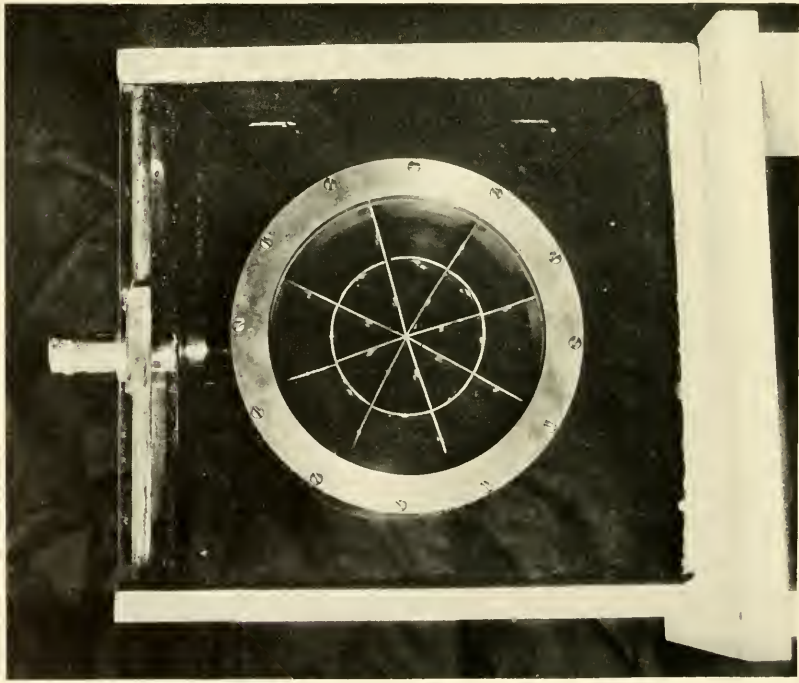

1. A 6-INCH CHRISTIANSEN LIGHT FILTER WITH WATER BATH

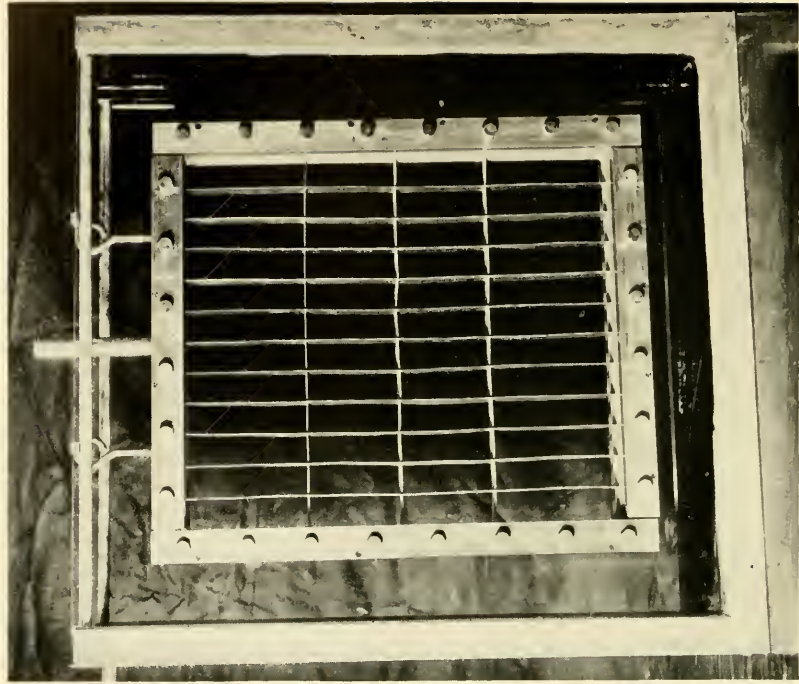

2. A 12X14-INCH CHRISTIANSEN LIGHT FILTER WITH WATER BATH

SMITHSONIAN MISCELLANEOUS COLLECTIONS

VOLUME 93, NUMBER 8

THE CLASSIFICATION OF THE EDRIOASTEROIDEA

(WITH ONE PLATE)

BY

R. S. BASSLER

Head Curator, Department of Geology,
U. S. National Museum



(PUBLICATION 3301)

CITY OF WASHINGTON
PUBLISHED BY THE SMITHSONIAN INSTITUTION
APRIL 4, 1935

The Lord Baltimore Press
BALTIMORE, MD., U. S. A.

THE CLASSIFICATION OF THE EDRIOASTEROIDEA

BY R. S. BASSLER

Head Curator, Department of Geology, U. S. National Museum

(WITH ONE PLATE)

The Edrioasteroidea, a group of Paleozoic echinoderms, regarded by specialists either as a distinct class of the Pelmatozoa allied to the cystids or as an aberrant order of the same division, has been the subject of so many detailed observations and changes in nomenclature that much confusion exists in its classification. Many of the genera have inexact limits assigned them, because they are based upon incorrect illustrations or described from species other than the cited genotype, or, again, because they are founded upon characters of uncertain value. Lastly, some authors, without regard to the rules of nomenclature, changed the generic endings to suit their ideas as to the relationships of the group, *Agelacrinites*, for example, becoming first *Agelacrinus* and later *Agelacystis*. Furthermore, it must be remembered that the camera-lucida drawings of years ago resulted in reversed images, the right side becoming the left, which in the edrioasteroids gave rise to a serious error since the direction of the ambulacra, a generic character now believed to be important, thus was reversed. However, most students paid little attention to the extent and direction of curvature of the ambulacra, including in the same genus forms most diverse in these respects.

In preparing the present classification the writer first of all proved, at least to himself, from a study of several hundred specimens of several Cincinnati species, that the amount of imbrication of the interambulacral plates, the width of the peripheral border of plates, and the number of arms or ambulacra may vary even in the same species; but the plate structure of the ambulacral and oral areas, and the direction and extent of curvature of the ambulacra, remained constant, thus affording good generic characters.

In their simplest form the edrioasteroids have a flexible theca or sacklike body composed of numerous more or less polygonal plates having a mouth on the upper surface at the central point of radiation of five straight or curved arms or ambulacra separated by interambulacral plates, and an anus with valvular covering occupying part

of an interray with a hydropore located between it and the mouth. These primitive echinoderms, free or attached by a part of the lower surface, developed into parasitic circular flattened forms, into elevated sacklike bodies or into cylindrical objects bearing the ambulacra at the top of a fused mass of plates. Starting at the left of the anal area and proceeding clockwise, the ambulacra are designated as follows: 1, left posterior; 2, left; 3, anterior (opposite the anal area); 4, right; 5, right posterior. These numbers are employed in the following descriptions.

Through the study of the Springer and Ulrich collections of Edriasteroidea in the National Museum, and of material lent by other institutions, the writer has been enabled to review the structure of most of the known genera and species of this group, the generic results of which are offered below. Here, the old genera are briefly redefined and six new generic names are proposed. This paper is introductory to a more complete publication that will include descriptions of additional new species upon which this classification is based.

Class EDRIOASTEROIDEA Billings, 1854-58

(Thyroidea Chapman, 1860; Agelacrinoidea S. A. Miller, 1877-1883; Cystasteroidea Steinman, 1888; Thecoidea Jaekel, 1895; Cystostellaroidea Steinman, 1904.)

Family AGELACRINITIDAE, new name

(Agelacrinidae Jaekel, 1899; Thecocystidae Jaekel, 1899)

Theca flexible, composed of thin plates attached temporarily or permanently by the greater part of the aboral surface and with ambulacra confined to the oral surface. A single row of ambulacral flooring plates overlapping proximally.

STROMATOCYSTITES Pompeckj, 1896

(*Stromatocystis* Bather, 1900)

Theca depressed, pentagonally globular in form with oral surface bearing five narrow, straight ambulacra separated by polygonal mosaic interambulacral plates with numerous intervening pores and the under surface completely occupied by smaller, less regular polygonal plates. Anal area slightly elevated, indistinct.

Genotype.—*S. pentangularis* Pompeckj, 1896. Middle Cambrian of Bohemia. *S. balticus* Jaekel, 1899, *S. walcotti* and var. *minor* Schuchert, 1919 are other species of the genus.

WALCOTTIDISCUS, n. gen.

Pentagonal form and general shape of theca as in *Stromatocystites*, but the oral face bears curved ambulacra, four (1-4) directed to the left and one (5) to the right. Furthermore, the edge of the oral surface is composed of a narrow band of very small nodose plates and the under side of larger polygonal plates imbricating. Anal area indistinct.

Genotype.—*W. typicalis*, new species. Middle Cambrian of British Columbia.

WALCOTTIDISCUS TYPICALIS, n. sp.

Plate I, fig. 1

Type specimen, free, depressed, globular, subpentagonal in outline, imbedded and somewhat distorted in hard shale. Oral face with five slightly curved ambulacra, four directed to the left and one, the right posterior, to the right, separated by polygonal interambulacral plates very slightly overlapping. Edge of oral side formed by a band consisting of five or more rows of very small elongate imbricating plates; basal side of theca as shown where pushed over oral face, occupied by large elongate polygonal, imbricated plates. Anal area not distinguishable with certainty.

Occurrence.—Burgess shale of Middle Cambrian, Burgess Pass near Field, B. C. (loc. 35 k).

Holotype.—U.S.N.M. no. 90754.

CYSTASTER Hall, 1871

(*Thecocystis* Jaekel, 1899)

Theca an elongate sack with the lower end attached to some foreign object. Ambulacra short and straight, five in number, with plates often rather nodose. Interambulacrals rounded or polygonal, mosaic, very minute (0.25 mm in diameter). Anal pyramid of 10 elongated, abruptly raised plates.

Genotype.—*Hemicystites* (*Cystaster*) *granulatus* Hall, 1871. Ordovician (Maysville) of Ohio.

CINCINNATIDISCUS, n. gen.

(*Hemicystites* of authors not Hall)

Like *Cystaster* except that the theca is not sacklike but depressed, attached, and that the interambulacral plates are squamose and imbricate distinctly, divided into larger central plates and a marginal zone of small nodose ones. Anal pyramid of nodose plates.

Genotype.—*Agelacrinus* (*Hemicystites*) *stellatus* Hall, 1866. Ordovician (Maysville) of Ohio. *Hemicystites carnensis* Foerste, 1914, belongs to this genus.

CARNEYELLA Foerste, 1916

Theca typically elevated, sacklike, attached by narrow basal part but also may occur as a thin circular expansion. Ambulacra curved, four (1-4) to left and one (5) to the right, with two rows of covering plates elevated and alternating with each other along the middle line. Oral area composed of three plates, one large and two small. Anal area of many small plates radially arranged. Surface of plates ornamented with minute pits and nodes.

Genotype.—*Agelacrinus* (*Lepidodiscus*) *pileus* Hall, 1866. Ordovician (Maysville) of Ohio. *Carneyella vetusta* Foerste, 1914, is related to *C. cincinnatiensis*, n. sp., next described. *Carneyella valcourensis* Clark, 1920, is doubtfully referred here.

CARNEYELLA CINCINNATIENSIS, n. sp.

Plate 1, fig. 10

Agelacrinus (*Lepidodiscus*) *cincinnatiensis* Hall (not Roemer), Descr. new species fossils Cincinnati, Ohio, p. 214, pl. 2, fig. 7, 1871 (advance sheets, p. 6, 1866); 24th Rep. New York State Cab. Nat. Hist., p. 214, pl. 6, fig. 7, 1872.

This well-marked species, erroneously referred to *Agelacrinus* (now *Isorophus*) *cincinnatiensis* Roemer, is readily distinguished from that form by its thin, depressed, almost flat theca attached by its entire aboral portion. Furthermore, the ambulacral plates are less elevated, all the plates are rather papillose, and there are only three oral plates.

Occurrence.—Maysville division (Corryville beds) of the Ordovician, Warren County, Ohio.

Holotype.—U.S.N.M. no. 40743.

ISOROPHUS Foerste, 1916

Theca depressed, circular, attached by the entire under surface. Ambulacra composed of two rows of plates with an intercalated series often present, more or less curved, four (1-4) to the left and the right posterior (5) to the right. Oral area occupied by numerous small plates. Margin composed of numerous rows of small plates slightly increasing in size inward. Interambulacral plates polygonal, becoming slightly imbricated. Anal area a circle of triangular plates regularly arranged.

Genotype.—*Agelacrinus cincinnaticensis* Roemer, 1851. Ordovician (Maysville) of Ohio, etc. Other species of *Isorophus* are *Agelacrinus austini* Foerste, 1914, *A. faberi* Miller, 1894, *A. warrenensis* James, 1883, and *A. holbrooki* James, 1878.

ISOROPHUSELLA, n. gen.

Like *Isorophus* but ambulacra 1, 2, and 3 directed to the left and 4 and 5 to the right, and the interambulacral plates strongly imbricating.

Genotype.—*Lebetodiscus inconditus* Raymond, 1915. Ordovician (Trenton) of Ontario, Canada.

ISOROPHUSELLA INCONDITUS (Raymond)

Plate I, fig. 11

Lebetodiscus inconditus Raymond, Ottawa Nat., vol. 29, pl. 1, fig. 1, 1915.

Theca a thin, slightly convex, circular disk, attached to or resting upon a limestone bed by its entire aboral surface, about 20 mm in diameter, exhibiting on its oral face a broad peripheral band of minute, closely imbricating plates, five ambulacral areas of which the oral portion is composed of many small irregular, angular plates, and each ambulacrum has two rows of covering plates alternating with each other and frequently developing additional small accessory plates along the midline between them. Ambulacra short, rather broad, three (1-3) curving to the left and two (4, 5) to the right. Interambulacral areas of larger, narrow, strongly imbricating plates. Anal area rather distinct, consisting of 10 elongate triangular smooth plates in one circle meeting at the center but not rising above the general surface.

Although very similar to species of *Isorophus*, this interesting form is readily distinguished by the different arrangement of the ambulacra.

Occurrence.—Trenton limestone, Hull, Quebec.

Plesiotype.—U.S.N.M. no. S.3871, Springer Coll.

STREPTASTER Hall, 1872

Theca as in *Carneyella*, except that the ambulacra all revolve strongly toward the left and are composed of highly elevated plates. Interambulacrals are small, polygonal, mosaic plates, 0.5 to 1.0 mm in diameter.

Genotype.—*Agelacrinus vorticellatus* Hall, 1866. Ordovician (Maysville) of Ohio. *S. reversatus* Foerste, 1914, and *S. septem-brachiatus* Miller and Dyer, 1878, are other species of *Streptaster*.

LEBETODISCUS Bather, 1908

Theca depressed, circular. Ambulacra curved, five in number, all directed toward the left, with mosaic interambulacral plates. Ambulacral plate structure apparently as in *Carneyella*. Anal area well defined in slightly wider interradius.

Genotype.—*Agelacrinites dicksoni* Billings, 1857. Ordovician (Trenton) of Ontario, Canada. *L. loriformis* Raymond, 1915, is a second described species.

FOERSTEDISCUS, n. gen.

Like *Lebetodiscus*, but ambulacra all directed to the right, short, broad, and strongly curved, and interambulacral plates polygonal but overlapping toward the center and highly imbricating around the periphery. Anal area of many small, irregularly arranged plates in slightly wider interradial area.

Genotype.—*F. grandis*, new species. Ordovician (Trenton) of Kentucky.

FOERSTEDISCUS GRANDIS, n. sp.

Plate 1, fig. 12

Theca a flattened disk, 25 mm in diameter, resting upon or attached to a layer of limestone. Ambulacra five, short, broad, all curved to the right, consisting of two rows of elongate covering plates slightly raised along the midline, and a single row of floor plates. Interambulacrals large, imbricating, but flat in the central areas, narrow, more numerous, and piled up on edge along the margin. Anal area large, distinct, occupying a slightly wider space, composed of many small imbricating plates arranged in circles, the smallest in the center.

Although resembling *Lebetodiscus dicksoni* (Billings), the right-handed arrangement of the ambulacra in this present species is a ready means of separation.

Occurrence.—Curdsville division of the Trenton, near Troy, Woodford County, Kentucky.

Holotype.—U.S.N.M. no. S.3191, Springer Coll.

PYRGOCYSTIS Bather, 1915

Oral surface of five broad, straight ambulacra mounted on a high cylindrical turret composed of wide, thin, closely imbricated plates.

Genotype.—*P. sardesoni* Bather, 1915. Ordovician (Decorah) of Minnesota. *Scalpellum sulcatum*, *procerum*, and *cylindricum* Aurivil-

lius, 1892, *Pyrgocystis octogona* Richter, 1930, *P. grayae* Bather, 1915, *P. ansticei* Bather, 1915, and *P. batheri* Ruedemann, 1925, are the other species of this genus.

HEMICYSTITES Hall, 1852

(*Hemicystis* Haeckel, 1896)

Theca a thin, flattened disk with oral arrangement and pitted plate structure of *Carneyella*, but ambulacra are short, broad, and straight. Anal pyramid elevated and composed of a circle of triangular plates regularly arranged.

Genotype.—*H. parasitica* Hall, 1852. Silurian (Rochester) of New York. *Agelacrinites bellulus*, *bohemicus*, *confertus*, *latiusculus*, *simplex*, *tener*, and *velatus* of Barrande, 1887, *A. rectiradiatus* Shideler, 1918, and *Agelacrinites billingsi* Chapman, 1860, *Lebetodiscus youngi* Raymond, 1915, and *L. chapmani* Raymond, 1915, are described species of *Hemicystites*.

THRESHERODISCUS Foerste, 1914

Agelacrinitidae with branched ambulacral rays having a pronounced trimerous origin. Interambulacrals large, squamose, imbricating in central part and smaller along border.

Genotype.—*T. ramosus* Foerste, 1914. Ordovician (Trenton) of Ontario, Canada.

AGELACRINITES Vanuxem, 1842

(*Agelacrinites* authors; *Agelacystis* Haeckel, 1895; *Haplocystites* Roemer, 1852; *Haplocystis* Bather, 1899)

Thin parasitic disks attached by entire aboral surface. Ambulacra five, long, narrow, much curved; two (4, 5) to the right and three (1-3) to the left. Interambulacral plates mosaic and sculptured, although slightly imbricating. Periphery formed by several rows of small plates followed by one row of much larger elongate ones. Anal area a circle of triangular, regularly arranged plates.

Genotype.—*A. hamiltonensis* Vanuxem, 1842. Devonian (Hamilton) of New York. *A. ephraemovianus* Bogolubov, 1926, *A. hanoveri* Thomas, 1924, and *A. rhenanus* Roemer, 1851, from the Devonian, and *A. blairi* Miller, 1894, *A. legrandensis* Miller and Gurley, 1894, from the Mississippian are referred to this genus.

DISCOCYSTIS Gregory, 1897

(*Echinodiscus* Worthen and Miller, 1883 (not Agassiz);
Ageladiscus Miller, 1897)

Like *Agelacrinites* except that four ambulacra are curved to left and one, the right posterior (5), to right, and that body is well developed and sacklike with many rows of elongate, narrow marginal plates.

Genotype.—*Echinodiscus optatus* Worthen and Miller, 1883 = *D.* (*Agelacrinites*) *kaskaskiensis* Hall, 1858. Mississippian of Illinois. *Echinodiscus sampsoni* Miller, 1891, is another species of this genus.

COOPERIDISCUS, n. gen.

Body depressed globular, free, entirely covered with plates; ambulacra long, very narrow, much curved, all turning to the right. Interambulacral plates strongly imbricate. Anal pyramid of regular triangular plates meeting at a point.

Genotype.—*Lepidodiscus alleganius* Clarke, 1901. Devonian (Chemung) of New York.

LEPIDODISCUS Meek and Worthen, 1868

Like *Cooperidiscus* but ambulacra 1-4 curve strongly to the left and 5, the right posterior one, to the right. Interambulacral plates small, strongly imbricating. Anal pyramid well developed.

Genotype.—*Agelacrinites squamosus* Meek and Worthen, 1868. Mississippian. *Agelacrinites beccheri* Clarke, 1901, *A. buttsi* Clarke, 1901, *Lepidodiscus lebouri* Sladen, 1879, and *L. milleri* Sharman and Newton, 1892, are the known species of this genus.

ULRICHIDISCUS, n. gen.

Body semiglobose with the oral side occupied by five narrow but well-defined, very long ambulacra all strongly curving to the left, with a well-defined anal pyramid of many long triangular plates in one circle, and interambulacral areas composed of polygonal but slightly imbricating plates.

Genotype.—*Agelacrinites pulaskiensis* Miller and Gurley, 1894. Mississippian (Chester) of Kentucky.

Family EDRIOASTERIDAE Bather

Theca flexible, depressed, usually globular, attached by the small central excavated part of the aboral surface; ambulacra strongly

curved and passing on to aboral surface; floor plates arranged in two series, one on each side of the ray, and alternating along the median line.

EDRIOASTER Billings, 1858

(*Cyclaster* Billings, 1857, not Cotteau, 1856; *Agelacrinites* Forbes, 1848, not Vanuxem; *Edriocystis* Haeckel, 1896; *Aesiocystites* Miller and Gurley, 1894; *Aesiocystis* Bather, 1900)

Sacklike, flexible theca attached by a small central portion of the aboral surface and with the ambulacra passing from the oral to aboral sides. Interambulacral plates mosaic. Ambulacra strongly curved, four (1-4) to the left and one (5) to the right, with an anal pyramid composed of many small plates, irregularly arranged.

Genotype.—*Cyclaster bigsbyi* Billings, 1857. Ordovician (Trenton) of Canada. *Agelacrinites buchianus* Forbes, 1848, *Edrioaster levis* Bather, 1914, *E. saratogensis* Ruedemann, 1912, and *Aesiocystites priscus* Miller and Gurley, 1894, are other species of this genus.

DINOCYSTITIS Bather, 1898

Oral surface convex, with five narrow ambulacra all strongly curved to the left and aboral surface composed of a thin flexible integument of narrow imbricating plates with a small central orifice for attachment.

Genotype.—*D. barroisi* Bather, 1898. Devonian of Belgium.

Family CYATHOCYSTITIDAE Bather

Edrioasteroidea in which the aboral portion consists of a fused solid mass of plates attached permanently to some foreign object.

CYATHOCYSTITIS Schmidt, 1880

Theca with oral surface much as in *Stromatocystites* but mounted upon a solid fused mass of stereom and permanently attached at the aboral end.

Genotype.—*C. plautini* Schmidt, 1880. Ordovician (Echinospheerites limestone) of Estonia.

CYATHOTHECA Jaekel, 1927

Like *Cyathocystis*, except that the ambulacral areas are apparently very narrow, practically hidden at the surface.

Genotype.—*C. suecica* Jaekel, 1927. Ordovician of Sweden.

POSITION UNCERTAIN

Family ASTROCYSTITIDAE, new name

(Steganoblastidae Bather)

ASTROCYSTITES Whiteaves, 1897*(Steganoblastus* Whiteaves, 1897)

Regarded by Bather as an edrioasteroid and by Hudson as a blastoid.

Family CYCLOCYSTOIDIDAE S. A. Miller, 1889

(order uncertain)

Genera *Cyclocystoides* Billings and Salter, 1858; *Narratwavyella* Foerste, 1920; *Savagella* Foerste, 1920.

EXPLANATION OF PLATE

- FIG. 1. *Walcottidiscus typicalis*, new genus and species. The holotype, $\times 3$, a crushed theca showing the oral side. Middle Cambrian (Burgess shale) Burgess Pass, near Field, British Columbia.
- FIGS. 2, 3. *Carneyella (Agelacrinus) pileus* Hall, 1866. View of oral side of theca and lateral view, $\times 2$, showing the sacklike form. Maysville (Fairmount formation): Cincinnati, Ohio.
- FIG. 4. *Cystaster (Hemicystites) granulatus* Hall, 1871. Side view, $\times 2$, of the elongate theca. Maysville (Fairmount formation): Cincinnati, Ohio.
- FIG. 5. *Streptaster (Agelacrinus) vorticellatus* Hall, 1856. Oral side of theca slightly enlarged, exhibiting the elevated ambulacra all revolving toward the left. Maysville (Fairmount formation): Cincinnati, Ohio.
- FIG. 6. *Cincinnatiidiscus (Agelacrinus) stellatus* Hall, 1866. Oral side of the depressed, attached theca, with straight arms, $\times 2$. Maysville (Fairmount formation): Cincinnati, Ohio.
- FIG. 7. *Ulrichidiscus (Agelacrinus) pulaskiensis* Miller and Gurley, 1894. View of the semiglobose theca, natural size, showing strong curvature of all ambulacra to the left. Chester (Glen Dean formation): Pulaski County, Ky.
- FIG. 8. *Pyrogocystis sardsoni* Bather, 1915. Side view of theca, $\times 1\frac{1}{2}$, showing the solid basal portion of many imbricating plates surmounted by the oral surface. Black River (Decorah) shales: St. Paul, Minn.
- FIG. 9. *Cooperidiscus (Lepidodiscus) alleganius* Clark, 1901. Oral side of the free, globular theca, $\times 1\frac{1}{2}$, exhibiting the very narrow ambulacra all curved to the right and the highly imbricated interambulacral plates. Chemung formation: New York.
- FIG. 10. *Carneyella cincinnatiensis*, new species. View of the attached, thin circular theca with ambulacral structure of *Carneyella*, $\times 4$. Maysville (Corryville formation): Warren County, Ohio.

FIG. 11. *Isorophusella inconditus* (Raymond, 1915). Example, $\times 4$, a depressed circular expansion with the plate structure of *Isorophus* but with 3 of the ambulacra directed to the left and 2 to the right. Trenton limestone: Hull, Quebec, Canada.

FIG. 12. *Foerstediscus grandis*, new genus and species. The holotype, $\times 2$, a flat circular expansion with the ambulacra all directed toward the right. Trenton (Curdsville limestone): Near Troy, Woodford County, Ky.

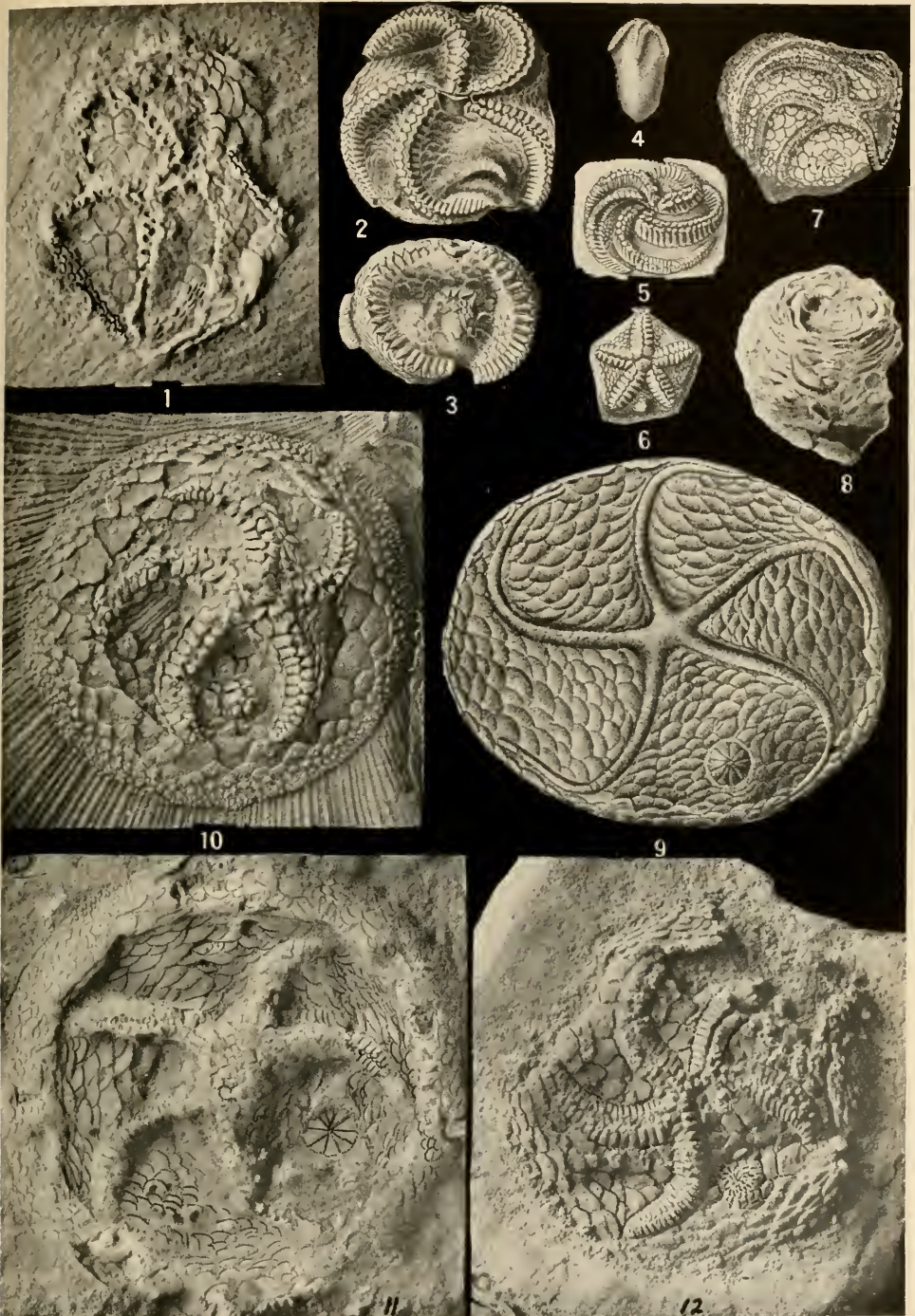

EDRIOASTEROIDEA

(For explanation, see page 10.)

SMITHSONIAN MISCELLANEOUS COLLECTIONS
VOLUME 93, NUMBER 9

NEW SPECIES OF TERTIARY CHEILOSTOME
BRYOZOA FROM VICTORIA, AUSTRALIA

(WITH NINE PLATES)

BY
FERDINAND GANU
AND
RAY S. BASSLER
Head Curator, Department of Geology,
U. S. National Museum



(PUBLICATION 3302)

CITY OF WASHINGTON
PUBLISHED BY THE SMITHSONIAN INSTITUTION
APRIL 26, 1935

The Lord Baltimore Press
BALTIMORE, MD., U. S. A.

NEW SPECIES OF TERTIARY CHEILOSTOME BRYOZOA
FROM VICTORIA, AUSTRALIA

By FERDINAND CANU

AND

RAY S. BASSLER

Head Curator, Department of Geology, U. S. National Museum

(WITH NINE PLATES)

INTRODUCTION

Through the kindness of various Australian friends, particularly Dr. F. Chapman, I have from time to time received many packages of washings containing Tertiary bryozoans from Victoria, with the result that as our studies upon other faunas progressed, Dr. Canu and I were able not only to classify more accurately, and make new observations upon, the known Victorian species but also to bring to light a number of interesting new forms. By the fall of 1931 such a volume of notes had accumulated that Dr. Canu began their compilation for publication. On February 11, 1932, he completed the editing and forwarded the final pages of these notes to me. The next morning, awakening with a slight headache, which grew steadily worse, he passed away from cerebral hemorrhage within a few hours. Thus came to a close our association in scientific work of almost a quarter of a century.

Economic conditions have prevented the publication of our complete work upon this subject, and the following abridged descriptions of the new species are issued at the present time to make them available for stratigraphic use in South Australian geology. Our studies would seem to indicate that the Australian Tertiary does not cover a long time period. The bryozoan faunas are so unlike the standard associations in the Tertiary of Europe and America that no definite correlations have been made so far. Indeed, their nearest relations seem to be in the recent seas around Australia. All the types of the species here described are in the collections of the United States National Museum.

R. S. BASSLER.

Class BRYOZOA Ehrenberg
 Order CHEILOSTOMATA Busk
 Suborder ANASCA Levinsen

Division MALACOSTEGA Levinsen, 1909

Family MEMBRANIPORIDAE Busk, 1854

ACANTHODESIA Canu and Bassler, 1920

ACANTHODESIA QUADRILATERA, n. sp.

Plate 1, fig. 10

Description.—The zoarium is subcylindrical, consisting of six rows of zooecia arranged around a central line. The zooecia are distinct, adjacent to each other through their mural rims, elongated, rectangular. The mural rim is thin, rounded, granulated, common to the adjacent zooecia; the cryptocyst is flat, smooth, shorter than the opesium. The opesium is anterior, elongated, elliptical, regular, bordered by a salient cushion, ornamented by small, very short spicules.

Measurements.—

$$\text{Opesium} \begin{cases} ho = 0.27 \text{ mm} \\ lo = 0.12 \text{ mm} \end{cases} \quad \text{Zooecium} \begin{cases} Ls = 0.48 \text{ mm} \\ lz = 0.25 \text{ mm} \end{cases}$$

Occurrence.—Muddy Creek (Balcombian), and Orbost, Gippsland (Janjukian), Victoria.

Holotype.—U.S.N.M. nos. 85582, 85583.

ACANTHODESIA REGULARIS, n. sp.

Plate 1, fig. 3

Description.—Zoarium of slightly flattened, subcylindrical branches of 6 to 10 rows of zooecia arranged around a central line. Zooecia rectangular with granulated mural rim and a cryptocyst about three fifths as long as the opesium, which is anterior and elongated.

Measurements.—

$$\text{Opesium} \begin{cases} ho = 0.30 \text{ mm} \\ lo = 0.18-0.20 \text{ mm} \end{cases} \quad \text{Zooecia} \begin{cases} Ls = 0.60-0.65 \text{ mm} \\ lz = 0.30-0.35 \text{ mm} \end{cases}$$

Occurrence.—Janjukian beds at Anticline Creek, Dartmoor, Victoria.

Cotypes.—U.S.N.M. no. 85581.

MEMBRANIPORA Blainville, 1830**MEMBRANIPORA AREOLATA**, n. sp.

Plate I, fig. 2

Description.—The zoarium is bilamellar; the fronds have four or five longitudinal rows of zoecia on each face. The zoecia are distinct, separated by a furrow or by a quadrangular area more or less broad, a little elongated, elliptical. The mural rim is thin, flat, of irregular width, smooth, and bears distally a small transverse triangular avicularium with two denticles and a pointed beak. The opesium is large, of the same form as the zoecium. The quadrangular area is very irregular in form and position. Ovicell unknown.

Measurements.—

$$\text{Opesium} \begin{cases} ho = 0.40-0.50 \text{ mm} \\ lo = 0.35 \text{ mm} \end{cases} \quad \text{Zoecium} \begin{cases} Ls = 0.60 \text{ mm} \\ ls = 0.45-0.50 \text{ mm} \end{cases}$$

Occurrence.—Janjukian; Aire Coastal Beds, Victoria.*Holotype.*—U.S.N.M. no. 60153.**VINCULARIA** Defrance, 1829**VINCULARIA GIGANTEA**, n. sp.

Plate I, fig. 4

Description.—The zoarium is rodlike (vincular) in form, composed of four or five longitudinal rows of cells arranged around a central line. The zoecia are distinct, *gigantic*, much elongated, rounded distally, narrowed proximally. The mural rim is thin, smooth, salient, rounded; the cryptocyst is very large, flat, smooth, or very finely granulated; the opesium is elliptical, elongated, margined by a salient swelling, terminal, and much smaller than the cryptocyst.

Measurements.—

$$\text{Opesium} \begin{cases} ho = 0.50-0.65 \text{ mm} \\ lo = 0.30 \text{ mm} \end{cases} \quad \text{Zoecium} \begin{cases} Ls = 2.10 \text{ mm} \\ ls = 0.65 \text{ mm} \end{cases}$$

Occurrence.—Janjukian beds at Anticline Creek, Dartmoor, Victoria.*Cotypes.*—U.S.N.M. no. 85905.**OTIONELLA** Canu and Bassler, 1917**OTIONELLA CIRCUMDATA**, n. sp.

Plate I, figs. 11, 12

Description.—The zoarium is a small, truncated, solid cone; the base is slightly convex and ornamented with sinuous radial lines; at

the periphery there are small elliptical cavities equally spaced, 11 or 12 in number, each containing a small avicularium. The zooecia are distinct, separated by their mural rim, arranged in radial rows, hexagonal. The mural rim is thin, salient; the cryptocyst is large, concave, deep, smooth; the opesium is terminal, orbicular, margined by a salient thread. The vibracula are very large, auriform, primoserial. The zooecia are not closed around the apex.

Measurements.—

$$\text{Opesium} \begin{cases} ho = 0.07 \text{ mm} \\ lo = 0.07 \text{ mm} \end{cases} \quad \text{Zooecium} \begin{cases} Ls = 0.25-0.30 \text{ mm} \\ ls = 0.25-0.30 \text{ mm} \end{cases}$$

Occurrence.—Balcombian beds at Muddy Creek, near Hamilton, Victoria.

Holotype.—U.S.N.M. no. 85807.

Family HINCKSINIDAE Canu and Bassler, 1927

HINCKSINA Norman, 1903

HINCKSINA UNISERIALIS, n. sp.

Plate 2, fig. 9

Description.—The zoarium incrusts bryozoa. The zooecia are arranged in uniserial, ramified branches; they are large, much elongated, pyriform, and bear proximally a long caudal gymnocyst. The opesium is large, anterior, oval; the mural rim is salient, beveled, a little enlarged at the base and ornamented with spines. The ovicell is endozooecial, rather large, convex, smooth.

Measurements.—

$$\text{Opesium} \begin{cases} ho = 0.40-0.45 \text{ mm} \\ lo = 0.20-0.25 \text{ mm} \end{cases} \quad \text{Zooecium} \begin{cases} Ls = 0.55-0.80 \text{ mm} \\ ls = 0.35-0.40 \text{ mm} \end{cases}$$

Occurrence.—Janjukian beds at Corio Bay, Geelong, Victoria.

Holotype.—U.S.N.M. no. 85756.

Family ALDERINIDAE Canu and Bassler, 1927

MEMBRANIPORIDRA Canu and Bassler, 1927

MEMBRANIPORIDRA (?) ASYMMETRICA, n. sp.

Plate 1, fig. 9

Description.—The zoarium is bilamellar. The zooecia are large, distinct, separated by a very deep furrow, elongated, elliptical; the gymnocyst almost entirely surrounds the opesium; it is convex and salient on the lateral parts, concave, deep, and hidden proximally. The mural rim is a thin, sinuous thread bearing a salient, simple, or

bifurcated apophysis on one side only; the opesium is elongated, elliptical, asymmetrical. The proximal gymnocyst bears the ovicell or a large, transverse, inconstant, elliptical avicularium. The ovicell is hyperstomial, globular, smooth, closed by the opercular valve.

Measurements.—

$$\text{Opesium} \begin{cases} ho = 0.37-0.45 \text{ mm} \\ lo = 0.15-0.20 \text{ mm} \end{cases} \quad \text{Zooecium} \begin{cases} Ls = 0.75 \text{ mm} \\ lz = 0.30-0.40 \text{ mm} \end{cases}$$

Occurrence.—Balcombian beds at Muddy Creek, Victoria.

Holotype.—U.S.N.M. no. 85794.

ELLISINIDRA Canu and Bassler, 1933

ELLISINIDRA PYRIFORMIS, n. sp.

Plate 4, fig. 7

Description.—The zoarium incrusts shell fragments. The zooecia are distinct, separated by a very shallow furrow, little elongated, elliptical, or almost transverse with a general *pyriform* aspect. The mural rim is very thin, filiform, rounded, smooth; it bears distally a small triangular, transverse avicularium; the opesium is very large and of the same form as the zooecium. The ovicell is small, convex, hyperstomial, closed by the operculum.

Measurements.—

$$\text{Opesium} \begin{cases} ho = 0.35-0.40 \text{ mm} \\ lo = 0.30-0.40 \text{ mm} \end{cases} \quad \text{Zooecium} \begin{cases} Ls = 0.45-0.50 \text{ mm} \\ lz = 0.40-0.50 \text{ mm} \end{cases}$$

Occurrence.—Janjukian beds at Flinders and Mount Gambier; Balcombian beds at Muddy Creek, Victoria.

Cotypes.—U.S.N.M. nos. 85691-85693.

STAMENOCELLA Canu and Bassler, 1917

STAMENOCELLA FUSIFORMIS, n. sp.

Plate 1, fig. 8

Description.—The zoarium is free, cylindrical. The zooecia are distinct, separated by a common mural rim, very elongated, *fusiform*; the gymnocyst is short, rectangular, very little convex, smooth. The mural rim is thin, rounded, smooth; the opesium is very much elongated, elliptical, terminal. The gymnocyst bears sporadically an orbicular avicularium. The ovicell is unknown.

Measurements.—

$$\text{Opesium} \begin{cases} ho = 0.45 \text{ mm} \\ lo = 0.15-0.18 \text{ mm} \end{cases} \quad \text{Zooecium} \begin{cases} Ls = 0.70 \text{ mm} \\ lz = 0.25 \text{ mm} \end{cases}$$

Occurrence.—Balcombian beds at Muddy Creek, Victoria.

Holotype.—U.S.N.M. no. 85881.

ALLANTOPORA Lang, 1914

ALLANTOPORA CONFINIS, n. sp.

Plate 1, fig. 5

Description.—The zoarium incrusts shells and forms uniserial or pluriserial rows of zooecia. The zooecia are distinct, separated by a deep furrow, very elongated pyriform, simply adjacent in the multi-serial portion; the gymnocyst is large, very convex, smooth, narrowed proximally, forming a caudal portion. The mural rim is thick, rounded, smooth. It bears exteriorly to the termen a row of large spines entirely surrounding the opesium. Ovicell and ancestrula unknown.

Measurements.—

$$\text{Opesium} \begin{cases} ho = 0.25-0.30 \text{ mm.} \\ lo = 0.18-0.20 \text{ mm} \end{cases} \quad \text{Zooecium} \begin{cases} Lz = 0.60-0.75 \text{ mm} \\ lz = 0.30-0.40 \text{ mm} \end{cases}$$

Number of zooecia in 4 mm^2 (= 4 square millimeters), 20-22.

Occurrence.—Balcombian beds at Muddy Creek and Janjukian at Flinders and Mount Gambier, Victoria.

Cotypes.—U.S.N.M. nos. 85598-85600.

AMPHIBLESTRUM Gray, 1848

AMPHIBLESTRUM GRANDE, n. sp.

Plate 1, fig. 1

Description.—The zoarium is bilamellar. The zooecia are distinct, separated by a deep furrow, very large, little elongated, ogival, surrounded on three quarters by a granular gymnocyst. The mural rim is salient, very thin distally, enlarged laterally, much attenuated proximally; the cryptocyst is shallow, flat, smooth, merging imperceptibly with the proximal gymnocyst; the opesium is large, terminal, transverse, pyriform, slightly trifoliated. The ovicell is hyperstomial, not closed by the opercular valve, globular, smooth, margined by an ectoecium, resting on the distal zooecium.

Measurements.—

$$\text{Opesium} \begin{cases} ho = 0.30-0.35 \text{ mm} \\ lo = 0.35-0.40 \text{ mm} \end{cases} \quad \text{Zooecium} \begin{cases} Lz = 0.75-0.90 \text{ mm} \\ lz = 0.50-0.75 \text{ mm} \end{cases}$$

Occurrence.—Balcombian beds at Muddy Creek, Victoria.

Holotype.—U.S.N.M. no. 85602.

RAMPHONOTUS Norman, 1894

RAMPHONOTUS (?) LAMELLOSUS, n. sp.

Plate 2, fig. 1

Description.—The zoarium is bilamellar. The zooecia are distinct, separated by a shallow furrow, very much elongated, pyriform. The

mural rim is thin, salient, sharp, smooth; the cryptocyst is flat, smooth, little deep, as long or longer than the opesium; it bears on its proximal portion a large transverse, triangular avicularium, with denticles, and in which the beak is very pointed and often slightly curved; the opesium is elongated, elliptical, narrowed distally by two small condyles symmetrically placed. The ovicell is hyperstomial, placed on the cryptocyst of the distal zooecium, globular, smooth, crowned by a zooecial avicularium.

Measurements.—

$$\text{Opesium} \begin{cases} ho = 0.20-0.25 \text{ mm} \\ lo = 0.13-0.15 \text{ mm} \end{cases} \quad \text{Zooecium} \begin{cases} Lz = 0.60-0.65 \text{ mm} \\ lz = 0.32-0.35 \text{ mm} \end{cases}$$

Number of zooecia in 4 mm^2 , 21.

Occurrence.—Balcombian beds at Muddy Creek and Janjukian at Dartmoor, Victoria.

Holotype.—U.S.N.M. nos. 85850, 85853.

Family HIANTOPORIDAE MacGillivray, 1895

TREMOPORA Ortmann, 1890

TREMOPORA ORBICULATA, n. sp.

Plate 2, fig. 3

Description.—The zoarium is unilamellar; the dorsal bears fenestrae. The zooecia are distinct, separated by a deep furrow in which the connecting tubes are visible, *orbicular*, or slightly elongated. The mural rim is thin distally and very much enlarged at the base; it bears two large distal spines and laterally a large elliptical avicularium placed very high, opposite which is situated a small avicularium or a short bifurcated spine. The opesium is elliptical or orbicular, of the same form as the zooecium.

Measurements.—

$$\text{Opesium} \begin{cases} ho = 0.50 \text{ mm} \\ lo = 0.40-0.50 \text{ mm} \end{cases} \quad \text{Zooecium} \begin{cases} Lz = 0.60-0.70 \text{ mm} \\ lz = 0.60-0.65 \text{ mm} \end{cases}$$

Occurrence.—Balcombian beds at Muddy Creek, Victoria.

Holotype.—U.S.N.M. no. 85894.

TREMOPORA STAMINIS, n. sp.

Plate 2, figs. 4, 5

Description.—The zoarium is unilamellar, free. On the dorsal the fenestrae are short, linear, narrow, and separate the six more or less broad connecting tubes. The surface is convex, smooth, ornamented with small salient radicular pores. The zooecia are distinct, separated

by a deep furrow at the angles of junction; the mural rim is thin distally, somewhat enlarged at the base; it bears two small distal spines, simple or bifurcated. The avicularium is large, triangular, without pivot, placed on the mural rim and in the immediate vicinity of the opercular valve. The beak is salient outside of the cell, very slightly curved. At its base a large spine with numerous reticulated *filamentous* branches covers the zooecium and unites itself to the opposite side of the mural rim; the lacunae are little numerous, long and linear. Always on the mural rim in front of the large avicularium there is a small, branching palmate spine placed above the last ramifications of the large spine. The ovicell is hyperstomial, small, convex, granular.

Measurements.—

Opesium $\left\{ \begin{array}{l} ho = 0.60-0.70 \text{ mm} \\ lo = 0.25-0.30 \text{ mm} \end{array} \right.$ Zooecia $\left\{ \begin{array}{l} Lz = 0.75 \text{ mm} \\ lz = 0.45-0.50 \text{ mm} \end{array} \right.$
 Number of zooecia in 4 mm^2 , 15.

Occurrence.—Balcombian beds at Muddy Creek, Victoria.

Holotype.—U.S.N.M. no. 85896.

Family ARACHNOPUSIIDAE Jullien, 1888

ARACHNOPUSIA Jullien, 1886

ARACHNOPUSIA LINEARIS, n. sp.

Plate 2, fig. 2

Description.—The zoarium is free and bilamellar. The zooecia are distinct, separated by a shallow furrow, very elongated, oval or elliptical; the frontal is a pericyst perforated by large lacunae; the latter are irregular, orbicular or crescentric, arranged irregularly in transverse rows. The opesium is semielliptical, transverse; the distal peristome is thin; the proximal lip is *linear*, thick, with a large indentation on one side; this indentation is the insertion of a large spine which has disappeared in fossilization. On the side opposite the indentation and adjacent to the peristome there is a small triangular avicularium, the beak oriented distally above each opesium, and adjacent to the peristome there is another small triangular avicularium, the beak of which is oriented proximally.

Measurements.—

Opesium $\left\{ \begin{array}{l} ho = 0.10 \text{ mm} \\ lo = 0.20 \text{ mm} \end{array} \right.$ Zooecium $\left\{ \begin{array}{l} Lz = 0.90-1.15 \text{ mm} \\ lz = 0.50 \text{ mm} \end{array} \right.$
 Number of zooecia in 4 mm^2 , 9-10.

Occurrence.—Balcombian beds at Muddy Creek, Victoria.

Holotype.—U.S.N.M. no. 85603.

Division COILOSTEGA Levinsen, 1909

Family OPESIULIDAE Jullien, 1888

RECTONYCHOCELLA Canu and Bassler, 1912**RECTONYCHOCELLA (?) DIMORPHOCELLA**, n. sp.

Plate 2, fig. 6

Description.—The zoarium is bilamellar. The ordinary zooecia are distinct, separated by a furrow of little depth, elongated, ogival. The mural rim is little distinct and is confused with the cryptocyst; the latter is smaller than the opesium, concave in its vicinity, somewhat convex proximally, slightly granular; the opesium is terminal, large, pyriform, narrowed toward the top by two small lateral condyles symmetrically placed. The accessory zooecia are membraniporoid; the elliptical opesium is surrounded by a rounded salient mural rim.

Measurements.—

$$\text{Opesium} \begin{cases} ho = 0.35-0.40 \text{ mm} \\ lo = 0.30 \text{ mm} \end{cases} \quad \text{Zooecium} \begin{cases} Lz = 0.65-0.80 \text{ mm} \\ lz = 0.55-0.60 \text{ mm} \end{cases}$$

Number of zooecia in 4 mm^2 , 12.*Occurrence.*—Balcombian beds at Muddy Creek, Victoria.*Holotype.*—U.S.N.M. no. 85854.**FLORIDINELLA** Canu and Bassler, 1917**FLORIDINELLA AUSTRALIENSIS**, n. sp.

Plate 1, fig. 6

Description.—The zoarium is free, bilamellar; the fronds are narrow and bear on each face four longitudinal rows of cells. The zooecia are distinct, separated by their common mural rim, elongated, ogival, much narrowed proximally. The mural rim is thin, salient, rounded; the cryptocyst is large, shallow, concave, smooth; the opesium is terminal, elongated, semielliptical, with the proximal border straight or concave; two small distal condyles, symmetrically arranged, slightly contract the opesium.

Measurements.—

$$\text{Opesium} \begin{cases} ho = 0.25-0.28 \text{ mm} \\ lo = 0.17-0.19 \text{ mm} \end{cases} \quad \text{Zooecium} \begin{cases} Lz = 0.60-0.70 \text{ mm} \\ lz = 0.40-0.43 \text{ mm} \end{cases}$$

Occurrence.—Balcombian beds at Muddy Creek, Victoria.*Holotype.*—U.S.N.M. no. 85722.

VIBRACELLA Waters, 1891

VIBRACELLA PARVULA, n. sp.

Plate 3, figs. 8, 9

Description.—The zoarium is a small truncated, solid cone; the base is ornamented with numerous radial ribs, dichotomously dividing, each containing one or two rows of large lunularian pores. The zooecia are distinct, separated by their mural rim, small, hexagonal, arranged in radial rows. The mural rim is thin, salient; the cryptocyst is concave, shallow, smooth; the opesium is terminal, semielliptic, little elongated, the proximal border being a little convex with two lateral, shallow, opesiular indentations. The vibracula are large, auriform, primoserial.

Measurements.—

$$\text{Opesium} \begin{cases} ho = 0.10-0.12 \text{ mm} \\ lo = 0.10 \text{ mm} \end{cases} \quad \text{Zooecium} \begin{cases} Ls = 0.25 \text{ mm} \\ ls = 0.25 \text{ mm} \end{cases}$$

Occurrence.—Balcombian beds at Muddy Creek, Victoria.

Holotype.—U.S.N.M. no. 85904.

SELENARIA Busk, 1854

SELENARIA TRIFOLIATA, n. sp.

Plate 2, figs. 7, 8

Description.—The zoarium is orbicular, cupuliform, thick, somewhat convex; the inner face is slightly concave, granular, costulated, with a row of large scattered pores in the middle of the radial ribs. The zooecia are distinct, adjacent through their mural rim, hexagonal, somewhat elongated or transverse. The mural rim is thin, salient; the cryptocyst is shallow, smooth, slightly concave. The opesium is slightly elongated, *trifoliate*; the distal portion is elliptical and bordered laterally by two triangular, very salient apophyses; the opesiular portion is linear, transverse, with two deep and rounded lateral indentations. The vibracula are primoserial, very large, auriform, separated into two parts by a salient point. The ancestrula is large and surrounded by 10 much smaller zooecia, of which 5 are vibracula.

Measurements.—

$$\text{Opesium} \begin{cases} ho = 0.27-0.30 \text{ mm} \\ lo = 0.24 \text{ mm} \end{cases} \quad \text{Zooecia} \begin{cases} Ls = 0.40-0.50 \text{ mm} \\ (marginal) \quad ls = 0.50 \text{ mm} \end{cases}$$

Occurrence.—Balcombian beds at Muddy Creek, Victoria.

Cotypes.—U.S.N.M. no. 85863.

SELENARIA GRANDICELLA, n. sp.

Plate 3, figs. 1, 2

Description.—The zoarium is orbicular, cupuliform, little convex. The zooecia are distinct, separated by a shallow furrow, very large, hexagonal, elongated or transverse; the cryptocyst is small, smooth, somewhat concave. The opesium is very large, trifoliate; the distal border bears a kind of vestibular arch; the lateral borders are sometimes a little salient; the proximal border is convex; the opesiular indentations are wide, deep, rounded. The vibracula are very large, auriform, primoserial; the inner distal portion is shallow. On the inner face of the zoarium there are broad radial ribs, convex, each perforated by two rows of large irregular lunularian pores.

Measurements.—

$$\text{Opesium} \begin{cases} ho = 0.35 \text{ mm} \\ lo = 0.30 \text{ mm} \end{cases} \quad \text{Zooecium} \begin{cases} Ls = 0.50 \text{ mm} \\ ls = 0.40-0.50 \text{ mm} \end{cases}$$

Occurrence.—Balcombian beds at Muddy Creek, Victoria.

Holotype.—U.S.N.M. no. 85864.

Family STEGANOPORELLIDAE Hincks, 1884

SIPHONOPORELLA Hincks, 1880**SIPHONOPORELLA LIVINGSTONEI, n. sp.**

Plate 3, fig. 5

Description.—The zoarium is unilamellar. The zooecia are distinct, separated by a shallow furrow, elongated, elliptical, narrowed at the base; the mural rim is somewhat salient, slightly thickened, granulated; the cryptocyst is shallow, flat, granulated. The opesium is large, terminal, irregular; the polypidial tube is very salient, oblique, wide.

Measurements.—

Diameter of polypidial tube, 0.12-0.15 mm

Width of opesium, 0.35 mm

$$\text{Zooecium} \begin{cases} Ls = 0.75-1.00 \text{ mm} \\ ls = 0.45 \text{ mm} \end{cases}$$

Number of zooecia in 4 mm², 12.

Occurrence.—Balcombian beds at Muddy Creek, Victoria.

Holotype.—U.S.N.M. no. 85884.

SIPHONOPORELLA FILIPARIETIS, n. sp.

Plate 3, fig. 4

Description.—The zoarium is unilamellar. The zooecia are distinct, separated by a deep furrow, elongated, ogival; the mural rim is round,

very thin, *filiform*, salient; the cryptocyst is shallow, flat, very finely granulated. The opesium is large, terminal, semielliptical, transverse; the polypidial tube is long, oblique, smooth, very narrow, expanded distally.

Measurements.—

Diameter of polypidial tube, 0.12 mm

Width of opesium, 0.40-0.45 mm

Zooecium $\left\{ \begin{array}{l} Lz = 0.85 \text{ mm} \\ lz = 0.45-0.50 \text{ mm} \end{array} \right.$

Occurrence.—Balcombian beds at Muddy Creek, Victoria.

Holotype.—U.S.N.M. no. 85883.

Family THALAMOPORELLIDAE Levinsen, 1902

THALAMOPORELLA Hincks, 1887

THALAMOPORELLA ELONGATA, n. sp.

Plate 2, fig. 10

Description.—The zoarium is bilamellar; the fronds are narrow. The zooecia are distinct, separated by their mural rim, much *elongated*, narrow, subrectangular; the mural rim is thin, rounded, salient, joined to the peristome; the cryptocyst is concave, rather deep, finely granulated. The aperture is orbicular or a little transverse; the peristome is thin, salient. The opesiules are wide, short, placed in the neighborhood of the aperture.

Measurements.—

Apertura $\left\{ \begin{array}{l} ha = 0.12-0.15 \text{ mm} \\ la = 0.15 \text{ mm} \end{array} \right.$ Zooecium $\left\{ \begin{array}{l} Lz = 0.70-0.75 \text{ mm} \\ lz = 0.25-0.30 \text{ mm} \end{array} \right.$

Number of zooecia in 4 mm², 21.

Occurrence.—Janjukian beds at Mitchell River, Victoria.

Holotype.—U.S.N.M. no. 85897.

Family ASPIDOSTOMATIDAE Jullien, 1888

MACROPORA MacGillivray, 1895

MACROPORA CLARKEI ATTENUATA, n. var.

Plate 4, fig. 1

Description.—The zooecia are separated by a furrow and not by a salient thread. Our specimens bear kenozoecia analogous to those figured by Waters, 1885. One of them bears traces of a broken ovicell.

Occurrence.—Janjukian beds at Flinders, Victoria.

Cotype.—U.S.N.M. no. 85781.

MACROPORA QUADRISERIATA, n. sp.

Plate 3, fig. 3

Description.—The zoarium is free, vincular, *quadriserial*. The zooecia are distinct, separated by a thin salient thread, elongated, hexagonal; the cryptocyst is large, little convex, perforated by numerous pores and ornamented with small tuberosities. The aperture is subterminal, large, semielliptical, transverse; the proximal border is straight with two small, lateral indentations; the peristome is very thick and salient. At the base of each zooecium there are two polygonal areas outlined by the ramifications of a separating thread.

Measurements.—

$$\text{Aperture} \begin{cases} ha = 0.15-0.20 \text{ mm} \\ la = 0.20-0.25 \text{ mm} \end{cases} \quad \text{Zooecium} \begin{cases} Ls = 1.25 \text{ mm} \\ ls = 0.75 \text{ mm} \end{cases}$$

Occurrence.—Janjukian beds at Bairnsdale, Victoria.*Holotype.*—U.S.N.M. no. 85705.

Division PSEUDOSTEGA Levinsen, 1909

Family CELLARIIDAE Hincks, 1880

CELLARIA Lamouroux, 1812

CELLARIA ORBICULARIA, n. sp.

Plate 4, fig. 3

Description.—The segments are quadrangular. The zooecia are distinct, separated by their mural rim, much elongated, hexagonal; the mural rim is thick, rounded, regular, the cryptocyst is shallow, very little convex, finely granulated. The opesium is large, *orbicular*, without any proximal denticle, margined by a thick pad. The ovicell is endotoichal; it is closed by an orbicular lamella forming a large area above the opesium.

Measurements.—

$$\text{Aperture} \begin{cases} ha = 0.20 \text{ mm} \\ la = 0.20 \text{ mm} \end{cases} \quad \text{Zooecium} \begin{cases} Ls = 0.90-1.00 \text{ mm} \\ ls = 0.45 \text{ mm} \end{cases}$$

Occurrence.—Janjukian beds at Anticline Creek, Dartmoor, Victoria.*Holotype.*—U.S.N.M. no. 85623.

CELLARIA ATTENUATA, n. sp.

Plate 4, fig. 4

Description.—The segments are long and rounded distally. The zooecia are distinct, separated by a very thin salient thread, somewhat

elongated, hexagonal; the cryptocyst is convex and forms a shallow cavity in front of the aperture. The aperture is semielliptical, transverse; the proximal border is straight or a little concave, with two very small lateral indentations. The ovicell is endotoichal; its orifice is a thin, crescentic slit. The avicularian zooecia have a large semielliptical, transverse opesium.

Measurements.—

$$\text{Aperture} \begin{cases} ha = 0.12-0.15 \text{ mm} \\ la = 0.15-0.17 \text{ mm} \end{cases} \quad \text{Zooecium} \begin{cases} Lz = 0.75-0.80 \text{ mm} \\ lz = 0.50 \text{ mm} \end{cases}$$

Occurrence.—Balcombian beds at Muddy Creek, Victoria.

Holotype.—U.S.N.M. no. 85617.

Family MEMBRANICELLARIIDAE Levinsen, 1909

OMOIOSIA Canu and Bassler, 1927

OMOIOSIA ELONGATA, n. sp.

Plate 3, fig. 11

Description.—The zoarium is free, bilamellar. The zooecia are distinct, separated by their mural rim, *elongated*, hexagonal, arranged in alternating transverse rows; the mural rim is thick, salient, triangular in section; the cryptocyst is deep, concave, very finely granular and entirely surrounds the opesium. The opesium is large, elliptical, elongated, not adjacent to the mural rim, surrounded by a salient thread. The special zooecia are larger but of the same form; their opesium is elliptical, median, and measures 0.30 by 0.15 mm.

Measurements.—

$$\text{Opesium} \begin{cases} ho = 0.20-0.22 \text{ mm} \\ lo = 0.15 \text{ mm} \end{cases} \quad \text{Zooecium} \begin{cases} Lz = 0.60-0.65 \text{ mm} \\ lz = 0.35-0.40 \text{ mm} \end{cases}$$

Number of zooecia in 4 mm², 24.

Occurrence.—Balcombian beds at Muddy Creek, Victoria.

Holotype.—U.S.N.M. no. 86955.

Division CELLULARINA Smitt, 1867

Family SCRUPOCELLARIIDAE Levinsen, 1909

CRASPEDOZOUM MacGillivray, 1886

CRASPEDOZOUM (?) ELONGATUM, n. sp.

Plate 3, figs. 6, 7

Description.—The zoarium is free, unilamellar, the fronds being formed of three longitudinal rows of zooecia. The zooecia are dis-

tinct, separated by a common mural rim, very *long*, ogival, a little narrowed proximally. The mural rim is thick, salient, rounded; the cryptocyst is very large, deep, concave, smooth; the opesium is terminal, elongated, elliptical, very finely crenulated. The zooecia of the median rows alone bear a large avicularian chamber; it is placed on the proximal cryptocyst where it occupies half of the length; it is rectangular and convex; the avicularium is median, small, salient, triangular, with the beak oriented proximally. The noncellular face of the fronds shows the limits of the lateral zooecia and their outlines without any apparent relation to the series of median zooecia.

Measurements.—

$$\text{Opesium} \begin{cases} ho = 0.35-0.40 \text{ mm} \\ lo = 0.25 \text{ mm} \end{cases} \quad \text{Zooecia} \begin{cases} Lz = 1.15 \text{ mm} \\ lz = 0.45 \text{ mm} \end{cases}$$

Occurrence.—Balcombian beds at Muddy Creek, Victoria.

Cotypes.—U.S.N.M. no. 85721.

Suborder ASCOPHORA Levinsen, 1909

Family CRIBRILINIDAE Hincks, 1880

CRIBRILINA Gray, 1848

CRIBRILINA CRASSICOLLIS, n. sp.

Plate 1, fig. 7

Description.—The zoarium is free, cylindrical, bifurcated, formed of four or five longitudinal rows of zooecia. The zooecia are distinct, separated by a furrow (when young), elongated, elliptical. A thick secondary calcification fills up the separating furrow joining together adjacent mural rims and surrounding the zooecium and the aperture. The frontal is convex, perforated by large lacunae arranged in quin-cunx. The apertural bar was rapidly covered with secondary calcification to form a thick peristome. The aperture is terminal, semielliptical, transverse, with a concave proximal border. Two small avicularia are arranged symmetrically on each side of the aperture.

Measurements.—

$$\text{Aperture} \begin{cases} ha = 0.10 \text{ mm} \\ la = 0.18 \text{ mm} \end{cases} \quad \text{Zooecia} \begin{cases} Lz = 0.65 \text{ mm} \\ lz = 0.45 \text{ mm} \end{cases}$$

Occurrence.—Balcombian beds at Muddy Creek, and Janjukian beds at Batesford, Victoria.

Cotypes.—U.S.N.M. nos. 85664, 85665.

CRIBRILINA TERMINATA CORONATA, n. var.

Plate 3, fig. 12

Description.—The distal portion of the peristome is *crowned* with three or four avicularia.

Measurements.—

$$\text{Apertura} \begin{cases} ha = 0.15-0.20 \text{ mm} \\ la = 0.20 \text{ mm} \end{cases} \quad \text{Zooecia} \begin{cases} Lz = 0.75-0.90 \text{ mm} \\ lz = 0.45-0.50 \text{ mm} \end{cases}$$

Number of zooecia in 4 mm^2 , 10-12.

Occurrence.—Balcombian at Muddy Creek, and Janjukian at Bairnsdale and Flinders, Victoria.

Cotypes.—U.S.N.M. nos. 85670, 85671.

CRIBRILINA TRISERIATA, n. sp.

Plate 3, fig. 10

Description.—The zoarium is free, unilamellar and formed of only *three rows* of cells. The zooecia are distinct, separated by a furrow, very elongated, elliptical; the mural rim is very thick, smooth, entirely surrounding the cell; the frontal is perforated by small lacunae separated by small granules. The aperture is semielliptical, transverse; it is surrounded by a very thick peristome joined with the mural rim. Two oblique, triangular avicularia are arranged symmetrically on each side of the proximal border of the aperture. The lateral zooecia are oblique and longer than the axial zooecia.

Measurements.—

$$\text{Apertura} \begin{cases} ha = 0.11 \text{ mm} \\ la = 0.16 \text{ mm} \end{cases} \quad \text{Zooecium} \begin{cases} Lz = 0.90 \text{ mm} \\ lz = 0.45 \text{ mm} \end{cases}$$

Occurrence.—Janjukian beds at Flinders and Batesford, Victoria.

Holotype.—U.S.N.M. nos. 85668, 85669.

Family PORINIDAE D'Orbigny, 1852

PORINA D'Orbigny, 1852**PORINA FISSURIFERA, n. sp.**

Plate 4, fig. 11

Porina gracilis (pars) MacGillivray, Trans. Roy. Soc. Victoria, vol. 4, p. 103, pl. 14, fig. 21, 1895.

Measurements.—

$$\text{Peristomice} \begin{cases} hp = 0.14 \text{ mm} \\ lp = 0.14 \text{ mm} \end{cases} \quad \text{Zooecium} \begin{cases} Lz = 1.5 \text{ mm} \\ lz = 0.60 (?) \text{ mm} \end{cases}$$

Number of zooecia in 4 mm^2 , 10-11.

Affinities.—This species differs from *Porina (Acropora) gracilis* Milne Edwards, 1836, in its larger micrometric dimensions, in its ascopore, which is a longitudinal slit, 0.10 mm in length, decorated with two lateral lips, and in the presence of small spathulated latero-frontal avicularia.

Occurrence.—Balcombian beds at Muddy Creek, and Janjukian at Mount Gambier, Victoria.

Holotype.—U.S.N.M. nos. 85584, 85585.

PACHYTHECELLA Bassler, 1934

PACHYTHECELLA UNIFASCIATA, n. sp.

Plate 4, fig. 5

Description.—The zoarium is free, bifurcated; the branches are somewhat compressed and formed of two longitudinal rows of cells opening only on one side. The dorsal is convex and smooth, except that the outlines of the zooecia are marked off by ridges. The zooecia are indistinct, little elongated, smooth, the frontal is perforated by a large orbicular ascopore. The peristomie is little salient, rather long; the peristomice is orbicular; the peristome is thin, nonsalient.

Measurements.—

$$\text{Peristomice} \begin{cases} hp = 0.15 \text{ mm} \\ lp = 0.15 \text{ mm} \end{cases} \quad \text{Zooecium} \begin{cases} Lz = 0.45 \text{ mm} \\ lz = 0.30 (?) \text{ mm} \end{cases}$$

Occurrence.—Balcombian beds at Muddy Creek, Victoria.

Holotype.—U.S.N.M. no. 85823.

PACHYTHECELLA ARMATA, n. sp.

Plate 4, fig. 8

Description.—The zoarium is free, bilamellar, formed of rather wide, compressed branches. The zooecia are indistinct, elongated, with very thick walls; the frontal is convex and covered with a large number of shallow pores. The peristomie is formed by the much thickened zooecial walls; the apertura is buried at the bottom of the peristomie and appears orbicular; the peristomice is orbicular and little distinct because of the absence of the peristome. On the marginal zooecia the ascopore is replaced by a large triangular, nonsalient, transverse, oblique avicularium; its beak is oriented exteriorly.

Measurements.—

$$\text{Peristomice} \begin{cases} hp = 0.15 \text{ mm} \\ lp = 0.15 \text{ mm} \end{cases} \quad \text{Zooecium} \begin{cases} Lz = 0.60-0.75 \text{ mm} \\ lz = 0.35 (?) \text{ mm} \end{cases}$$

Number of zooecia in 4 mm^2 , 18.

Occurrence.—Balcombian beds at Muddy Creek, Victoria.

Holotype.—U.S.N.M. no. 85822.

Family TUBUCELLARIIDAE Busk, 1884

TUBITRABECULARIA Canu and Bassler, 1934

TUBITRABECULARIA PRODITOR, n. sp.

Plate 4, fig. 10

Description.—The zoarium is articulated; the segments are large, clavate, somewhat compressed at their extremity. The zooecia are indistinct, much elongated; the frontal is convex, smooth, bordered by large pores, and formed by an epicalcification hiding the peristomie and supported by thin trabeculae radiating from the ascopore. The peristomie (when visible) is long, oblique, much reduced, smooth, tubular; the peristomice is orbicular; the peristome is thin, smooth, sharp. The ascopore is small, tubular (when visible), placed at the base of the peristomie. The ovicelled zooecia are globular, salient, often grouped in variable numbers.

Measurements.—

$$\text{Peristomice} \begin{cases} hp = 0.10 \text{ mm} \\ lp = 0.10 \text{ mm} \end{cases} \quad \text{Zooecium} \begin{cases} Ls = 0.70-0.80 \text{ mm} \\ ls = 0.40 (?) \text{ mm} \end{cases}$$

Number of zooecia in 1 mm^2 , 5.*Occurrence.*—Balconbian beds at Muddy Creek, Victoria.*Holotype.*—U.S.N.M. no. 85886.

Family PETRALIIDAE Levinsen, 1909

PETRALIELLA MacGillivray, 1887

PETRALIELLA VULTUR AVICULIFERA, n. var.

Plate 5, fig. 2

Description.—The zoarium is unilamellar. The zooecia are distinct, separated by a furrow, large, elongated, capitate; the frontal is convex and punctured by scattered pores. An avicularian umbo, very salient, very long and somewhat oblique, is placed before the aperture; the mandible is very long and placed laterally. The aperture is large, suborbicular, a little transverse; a small expanded lyrule is placed on the proximal border in the vicinity of two very short cardelles; the peristome is very thin, smooth, ornamented with four spines. On each side of the aperture there is a small elliptical *avicularium*, with pivot, oriented proximally; sporadically on the longer zooecia there are one or two small elliptical avicularia with pivot oriented distally.

Measurements.—

$$\text{Aperture} \begin{cases} ha=0.16 \text{ mm} \\ la=0.20 \text{ mm} \end{cases} \quad \text{Zooecia} \begin{cases} Lz=0.75-1.00 \text{ mm} \\ lz=0.40 \text{ mm} \end{cases}$$

Number of zooecia in 4 mm^2 , 12.

Occurrence.—Balcombian beds at Muddy Creek, Victoria.

Holotype.—U.S.N.M. no. 85825.

PETRALIELLA TRACTIFERA, n. sp.

Plate 5, fig. 1

Description.—The zoarium is unilamellar, perhaps orbicular. The zooecia are distinct, separated by a salient thread or by a thickened band, large, elliptical, elongated, swollen; the frontal is a tremocyst with large expanded pores and bearing an orbicular, salient, avicularian umbo. The shield is a narrow circular band surrounding the aperture; it bears from four to six large hollow spines. The aperture is large, circular; it bears proximally, a small lyrule and two transverse cardelles always placed at the same level as the distal border of the lyrule; the peristome is thin, smooth, salient, strengthened exteriorly by the shield. On the dorsal face of the zoarium, the zooecia are distinct, subhexagonal, separated by thickened salient bands forming an interzooecial epicalcification.

Measurements.—

$$\text{Aperture} \begin{cases} ha=0.15-0.20 \text{ mm} \\ la=0.15-0.20 \text{ mm} \end{cases} \quad \text{Zooecia} \begin{cases} Lz=0.75-0.80 \text{ mm} \\ lz=0.60 \text{ mm} \end{cases}$$

Number of zooecia in 4 mm^2 , 10.

Occurrence.—Balcombian beds at Muddy Creek, Victoria.

Holotype.—U.S.N.M. no. 85824.

PETRALIELLA (?) DENTICULATA, n. sp.

Plate 4, fig. 9

Description.—The zoarium is bilamellar with wide fronds. The zooecia are distinct, separated by a salient thread, very elongated, irregular; the frontal is somewhat convex, granulose, bordered with areolar pores. The peristomie is long, the peristomie is oblique, very irregular, with proximal border denticulated by two or three salient rounded mucrons. The aperture is buried at the bottom of the peristomie and bears a well-developed lyrule.

$$\text{Measurements.}—\text{Zooecium} \begin{cases} Lz=0.75-1.00 \text{ mm} \\ lz=0.40-0.50 \text{ mm} \end{cases}$$

Number of zooecia in 4 mm^2 , 15.

Occurrence.—Balcombian beds at Muddy Creek, Victoria.

Holotype.—U.S.N.M. no. 85826.

Family GIGANTOPORIDAE Bassler, 1935

GIGANTOPORA Ridley, 1881

GIGANTOPORA HYSTRIX, n. sp.

Plate 4, fig. 2

Description.—The zoarium is free, cylindrical. The zooecia are distinct, separated by a large prominent thread, somewhat elongated, hexagonal; the frontal is convex, pierced by numerous small tremopores separated from one another by protruding spinelike granules. The peristomie is long, salient, partly buried on the distal zooecium; the peristomice is oblique, elliptical, transverse. The spiramen is large (0.17 mm wide) crescentic, somewhat tubular. The two avicularia are small, triangular, almost transverse.

Measurements.—

$$\text{Peristomice} \begin{cases} hp = 0.10 \text{ mm} \\ lp = 0.15 \text{ mm} \end{cases} \quad \text{Zooecium} \begin{cases} Lz = 0.85 \text{ mm} \\ lz = 0.75 \text{ mm} \end{cases}$$

Occurrence.—Balcombian beds at Muddy Creek, Victoria.

Holotype.—U.S.N.M. no. 85728.

GIGANTOPORA HEXAGONALIS, n. sp.

Plate 4, fig. 6

Description.—The zoarium is unilamellar. The zooecia are distinct, separated by a salient thread, a little elongated, *hexagonal*; the frontal is transversely concave, formed by a tremocyst with small pores separated by regular tuberosities. The peristomice is subcircular; the peristome is smooth, thin, salient. The spiramen is large (0.14 mm wide), crescentic, bordered by a distinct thread. The two avicularia are large, triangular, oblique, with pivot. The beaks join on the median zooecial axis above the spiramen and form an angle with thickened lines which partially cover the peristomice.

Measurements.—

$$\text{Peristomice} \begin{cases} hp = 0.20 \text{ mm} \\ lp = 0.24 \text{ mm} \end{cases} \quad \text{Zooecium} \begin{cases} Lz = 0.90 \text{ mm} \\ lz = 0.55 \text{ mm} \end{cases}$$

Number of zooecia in 4 mm², 12.

Occurrence.—Balcombian beds at Muddy Creek, and Janjukian at Flinders, Victoria.

Holotype.—U.S.N.M. nos. 85725, 85726.

GIGANTOPORA PERFORATA, n. sp.

Plate 5, fig. 10

Description.—The zoarium is free, bilamellar, formed of fronds of varying width. The zooecia are large, little distinct, elongated;

the frontal is little convex, punctured by rather large tremopores. The peristomie is large, orbicular or elliptical and elongated; the peristomie is very short; the peristome is rather thick, smooth, little salient. The spiramen is a simple *perforation* in the short peristomie. The ovicell is hyperstomial, opening largely in the peristome, very large, globular, covered with scattered tremopores. The two avicularia are small, triangular, transverse or oblique, pointed downward.

Measurements.—

Peristomie	{	$hp = 0.22-0.25$ mm	Zooecium	{	$Ls = 0.90-1.00$ mm
		$lp = 0.18$ mm			$ls = 0.65-0.70$ mm

Number of zooecia in 4 mm², 8-10.

Occurrence.—Balcombian beds at Muddy Creek and Janjukian beds at Flinders, Victoria.

Cotypes.—U.S.N.M. no. 85729.

GIGANTOPORA ELONGATA, n. sp.

Plate 5, fig. 5

Description.—The zoarium is free, cylindrical. The zooecia are distinct, separated by a furrow bordered by two very thick salient threads, large, very *elongated*, sinuous; the frontal is a tremocyst, little convex and penetrated by rather large pores. The peristomie is short; the peristomie is orbicular or elliptical and transverse; the peristome is smooth, thick, little salient. The spiramen is large (0.25 mm wide) simple, not salient, marginated, somewhat concentric. The two peristomial avicularia are large, triangular, with pivot; their beak is pointed, oriented toward the peristomie.

Measurements.—

Peristomie	{	$hp = 0.20$ mm	Zooecia	{	$Ls = 1.25-1.30$ mm
		$lp = 0.22-0.25$ mm			$ls = 0.65-0.75$ mm

Number of zooecia in 4 mm², 6.

Occurrence.—Janjukian beds at Gellibrand, Victoria.

Holotype.—U.S.N.M. no. 85727.

GIGANTOPORA MINUTIPOROSA, n. sp.

Plate 5, fig. 9

Description.—The zoarium is unilamellar, thick. The zooecia are distinct, separated by a thick salient thread, elongated, subhexagonal; the frontal is somewhat convex, pierced with *very small pores* separated by small granulations. The peristomie is short, somewhat buried in the distal zooecium; the peristomie is large, orbicular or elliptical, and transverse, little oblique; the peristome is salient, thick granulated,

or crenulated. The spiramen is large (0.20 mm wide) distally tubular, granulated, oblique, oriented proximally. The two frontal avicularia are relatively small, triangular, with pivot; the beak is rounded and united to the thickened proximal portion of the peristome.

Measurements.—

Peristomie $\left\{ \begin{array}{l} hp = 0.22 \text{ mm} \\ lp = 0.22-0.27 \text{ mm} \end{array} \right.$ Zooecium $\left\{ \begin{array}{l} Lz = 1.08-1.17 \text{ mm} \\ lz = 0.63-0.72 \text{ mm} \end{array} \right.$
 Number of zoecia in 4 mm², 7.

Occurrence.—Janjukian beds at Flinders and Batesford, Victoria.

Holotype.—U.S.N.M. nos. 85730, 85731.

GEPHYROPHORA Busk, 1884

GEPHYROPHORA BILAMELLARIA, n. sp.

Plate 5, fig. 3

Description.—The zoarium is free, *bilamellar*; the fronds are broad and very thick. The zoecia are distinct, separated by a salient thread, large, rectangular, somewhat elongated; the frontal is little convex, almost flat, and formed by a granular tremocyst with numerous pores. The apertura is large, oval, with a broad, rounded proximal sinus; the peristome is thin and very little salient. The ovicell is very large, globular, of the same nature as the frontal. On each side of the apertura there is a large triangular avicularium with pivot, with beak very pointed and oriented obliquely toward the apertural sinus.

Measurements.—

Aperture $\left\{ \begin{array}{l} ha = 0.20 \text{ mm} \\ la = 0.20 \text{ mm} \end{array} \right.$ Zooecium $\left\{ \begin{array}{l} Lz = 0.70 \text{ mm} \\ lz = 0.50 \text{ mm} \end{array} \right.$
 Number of zoecia in 4 mm², 11.

Occurrence.—Balcombian beds at Muddy Creek, Victoria.

Holotype.—U.S.N.M. no. 85723.

SPIROPORINA Stoliczka, 1864

SPIROPORINA TENUIS, n. sp.

Plate 5, fig. 4

Description.—The zoarium is free, cylindrical, bifurcated, very thin, formed of only four rows of cells. The zoecia are distinct, separated by a very small and very finely crenulated thread, much elongated, subcylindrical; the frontal is convex, perforated by very small tremopores arranged in linear rows and separated by scattered granulations. The peristomie is little apparent and of variable length. The peristomie is elliptical, transverse, oblique; the peristome is

rather thick, fimbriated or crenulated. The spiramen is a small perforation placed in the vicinity of the peristomice.

Measurements.—

$$\text{Peristomice} \begin{cases} hp = 0.08 \text{ mm} \\ lp = 0.15 \text{ mm} \end{cases} \quad \text{Zoocium} \begin{cases} Lz = 0.45-0.50 \text{ mm} \\ lz = 0.25 \text{ mm} \end{cases}$$

Occurrence.—Balcombian at Muddy Creek and Janjukian at Corio Bay, Geelong, etc., Victoria.

Holotype.—U.S.N.M. no. 85738.

Family SCHIZOPORELLIDAE Bassler, 1935

Subfamily SCHIZOPORELLAE Canu and Bassler, 1917

BUFFONELLODES Strand, 1928

BUFFONELLODES BACULINA, n. sp.

Plate 5, fig. 11

Description.—The zoarium is free, cylindrical, formed of five or six longitudinal rows of zooecia. The zooecia are distinct, separated by a furrow, somewhat elongated, lozenge shape, wide; the frontal is convex, smooth. The apertura is elongated, oval, terminated proximally by a wide rounded sinus; the peristome is wide, smooth, little salient.

Measurements.—

$$\text{Apertura} \begin{cases} ha = 0.10-0.12 \text{ mm} \\ la = 0.08 \text{ mm} \end{cases} \quad \text{Zoocium} \begin{cases} Lz = 0.60-0.75 \text{ mm} \\ lz = 0.50 \text{ mm} \end{cases}$$

Occurrence.—Balcombian beds at Muddy Creek, and Janjukian beds at Boggy Creek, Victoria.

Holotype.—U.S.N.M. nos. 85606, 85607.

STEPHANOSELLA Canu and Bassler, 1917

STEPHANOSELLA SEXSPINOSA, n. sp.

Plate 6, fig. 1

Description.—The zoarium is incrusting. The zooecia are distinct, separated by a furrow, rather large, wide, ensiform; the frontal is convex, smooth. The aperture is suborbicular; the proximal border bears a wide rounded sinus; the peristome is very thin, little salient, ornamented with six very short spines. On each side of the aperture, distant from the peristome, there is a distinct, cylindrical, avicularian chamber, terminated by an orbicular, oblique orifice. The ovicell is hyperstomial, not closed by the operculum, very salient, globular, granulose, ornamented with a large, smooth triangular area. On certain zooecia, the aperture is hidden by a large flat mucron; it bears

very frequently the base of a very large transverse avicularium with spatulate pivot in which the beak is supported on the peristome of an adjacent zooecium.

Measurements.—

Aperture	$\left\{ \begin{array}{l} ha = 0.12 \text{ mm} \\ la = 0.12 \text{ mm} \end{array} \right.$	(including oral sinus) Zooecium	$\left\{ \begin{array}{l} Ls = 0.65 \text{ mm} \\ ls = 0.40-0.55 \text{ mm} \end{array} \right.$
----------	---	---------------------------------------	--

Number of zooecia in 4 mm^2 , 16.

Occurrence.—Balcombian beds at Muddy Creek, Victoria.

Holotype.—U.S.N.M. no. 85885.

DAKARIA Jullien, 1903

DAKARIA CRASSOCIRCA, n. sp.

Plate 6, fig. 7

Description.—The zoarium is free, cylindrical, formed by four longitudinal rows of zooecia. The zooecia are distinct, separated by a furrow, at the bottom of which is a salient thread, elongated, elliptical; the frontal is very convex and covered with large infundibuliform tremopores. The aperture is transverse, semielliptical; the proximal border bears a very wide rounded sinus; the peristome is complete, *very thick*; between the inner proximal portion and the aperture, there is a small armature of little depth and characteristic of the genus. Ovicell unknown.

Measurements.—

Aperture	$\left\{ \begin{array}{l} ha = 0.12 \text{ mm} \\ la = 0.15 \text{ mm} \end{array} \right.$	Zooecium	$\left\{ \begin{array}{l} Ls = 0.84 \text{ mm} \\ ls = 0.55 \text{ mm} \end{array} \right.$
----------	---	----------	---

Occurrence.—Janjukian beds at Bairnsdale, Victoria.

Holotype.—U.S.N.M. no. 85683.

SCHIZOBRACHIELLA Canu and Bassler, 1920

SCHIZOBRACHIELLA HEXAGONALIS, n. sp.

Plate 6, fig. 5

Description.—The zoarium is free, unilamellar. The zooecia are distinct, separated by a salient thread, *hexagonal*, somewhat elongated; the frontal is convex and formed of a tremocyst with small, numerous pores. The aperture, orbicular in aspect, is formed by a large semicircular anter and by a concave poster notched by a wide, shallow sinus separated from the anter by two small lateral indentations. Laterally, at the height of the apertural sinus there is either a longitudinal slit or a small elongated avicularium.

Measurements.—

$$\text{Aperture} \begin{cases} ha = 0.15-0.17 \text{ mm} \\ la = 0.17 \text{ mm} \end{cases} \quad \text{Zoocium} \begin{cases} Lz = 0.80 \text{ mm} \\ lz = 0.50-0.55 \text{ mm} \end{cases}$$

Number of zoecia in 4 mm^2 , 11.

Occurrence.—Balcombian beds at Muddy Creek, Victoria.

Holotype.—U.S.N.M. no. 85861.

CHIASTOSELLA Canu and Bassler, 1934**CHIASTOSELLA LAMELLATA, n. sp.**

Plate 6, fig. 8

Description.—The zoarium is free and lamellar; the fronds are more or less wide, bifurcated. The zoecia are little distinct, vaguely separated by a white line irregularly placed between the areolar pores, elongated; the frontal is narrow, bordered by two scattered rows of areolar pores concealing the little apparent pleurocyst. The aperture is semicircular; the proximal border is rectilinear and notched by a straight, short sinus rounded at its extremity; the peristome is thick, little salient, with four or five large distal spines. The ovicell is large, embedded in the distal zoecium, hyperstomial, not closed by the operculum; the ectozoecium is large, circular, convex, smooth, ornamented on the periphery with lines of small pores arranged radially. The two avicularia are arranged transversely on the transverse median axis of the zoecium; they are long and thin with pivot, very pointed, projecting on the adjacent zoecia; their base is placed on the exterior line of areolar pores.

Measurements.—

$$\text{Aperture} \begin{cases} ha = 0.15 \text{ mm} \\ la = 0.10-0.12 \text{ mm} \end{cases} \quad \text{Zoocium} \begin{cases} Lz = 0.60-0.65 \text{ mm} \end{cases}$$

Number of zoecia in 4 mm^2 , 16 to 20.

Occurrence.—Balcombian beds at Muddy Creek, and Janjukian at Mount Gambier, Victoria.

Cotypes.—U.S.N.M. nos. 85630, 85631.

CHIASTOSELLA GIBBERA, n. sp.

Plate 6, fig. 2

Description.—The zoarium is unilamellar. The zoecia are little distinct, elongated, irregular; the frontal is convex, ornamented with a longitudinal, median gibbosity surrounded by a double row of scattered areolar pores often separated by pseudocostules. The aperture is semielliptical, transverse; the proximal border is somewhat concave and bears a very narrow linear sinus; the peristome is non-

salient and bears four inconstant spines. The zoecial avicularium is transverse, thin with pivot, nonsalient, inconstant. The ovicell is unknown.

Measurements.—

$$\text{Aperture} \begin{cases} ha = 0.12 \text{ mm} \\ la = 0.15 \text{ mm} \end{cases} \quad \text{Zoecium} \begin{cases} Lz = 0.60 \text{ mm} \\ lz = 0.25-0.30 \text{ mm} \end{cases}$$

Number of zoecia in 4 mm^2 , 18-20.

Occurrence.—Janjukian beds at Bairnsdale, Victoria.

Cotype.—U.S.N.M. no. 85629.

CHIASTOSELLA POROSA, n. sp.

Plate 6, fig. 4

Description.—The zoarium is free, unilamellar. The zoecia are distinct, separated by a furrow, ogival, wide, often transverse; the frontal is convex, very *porous*, with much reduced pleurocyst. The aperture is suborbicular; the concave poster bears a rounded sinus of little depth; the peristome is wide, nonsalient, with three or four large spines. The avicularium is placed transversely on the median axis of the zoecium; it is very long, with pivot, with a beak thinned and placed on a convex, porous chamber. Ovicell unknown.

Measurements.—

$$\text{Aperture} \begin{cases} ha = 0.16-0.20 \text{ mm} \\ la = 0.20-0.22 \text{ mm} \end{cases} \quad \text{Zoecium} \begin{cases} Lz = 0.70 \text{ mm} \\ lz = 0.80 \text{ mm} \end{cases}$$

Number of zoecia in 4 mm^2 , 12.

Occurrence.—Balcombian beds at Muddy Creek, Victoria.

Holotype.—U.S.N.M. no. 85632.

CHIASTOSELLA GRANDICELLA, n. sp.

Plate 6, fig. 3

Description.—The zoarium is free, unilamellar. The zoecia are distinct, separated by a furrow, *very large*, ogival, very wide, transverse; the frontal is convex, porous, bordered by three rows of areolar pores leaving only a small frontal pleurocyst. The aperture is large, suborbicular; the proximal border is very concave with a wide, rounded, rather deep sinus; the peristome is very thick, nonsalient and provided with four large distal spines. The zoecial avicularium is very large, rather long, with pivot, arranged transversely; the beak is pointed. Ovicell unknown.

Measurements.—

$$\text{Aperture} \begin{cases} ha = 0.22-0.25 \text{ mm} \\ la = 0.22 \text{ mm} \end{cases} \quad \text{Zoecium} \begin{cases} Lz = 0.90 \text{ mm} \\ lz = 0.80 \text{ mm (ir-} \\ \text{regular)} \end{cases}$$

Number of zoecia in 4 mm^2 , 5.

Occurrence.—Balcombian beds at Muddy Creek, Victoria.

Holotype.—U.S.N.M. no. 85628.

CHIASTOSELLA PARVIPOROSA, n. sp.

Plate 6, fig. 10

Description.—The zoarium is unilamellar. The zooecia are distinct, separated by a deep furrow, very large, ogival, little elongated, wide; the frontal is convex, covered with relatively *small pores*, without pleurocyst. The aperture, transverse and semielliptical in aspect, bears on its concave proximal border a small rounded sinus; the peristome is very thick, nonsalient, garnished with four large hollow spines. Ovicell unknown. The avicularium is large, transverse, borne on a large porous convex chamber; the beak is rather pointed; its base is placed on the first row of pores.

Measurements.—

$$\text{Aperture} \begin{cases} ha = 0.28 \text{ mm} \\ la = 0.25-0.27 \text{ mm} \end{cases} \quad \text{Zooecium} \begin{cases} Lz = 0.50-0.60 \text{ mm} \\ lz = 0.50-0.55 \text{ mm} \\ \text{(without avicularium)} \end{cases}$$

Number of zooecia in 4 mm², 5.

Occurrence.—Janjukian beds at Flinders, Victoria.

Holotype.—U.S.N.M. no. 85627.

EMBALLOTHECA Levinsen, 1909

EMBALLOTHECA INCLINATA, n. sp.

Plate 6, fig. 6

Description.—The zoarium is bilamellar, with broad fronds. The zooecia are distinct, separated by a white nonsalient thread; the frontal is flat, perforated by large polygonal, expanded tremopores, rectangular and somewhat elongated. The aperture is semielliptical, transverse; the proximal border bears a semicylindrical mucron, *inclined* in the aperture; two small lateral cardelles are placed at the level of the distal border of the mucron; the peristome is incomplete, wide, smooth, nonsalient. The ovicells are enormous, embedded in the distal zooecium, very convex and salient, covered with large pores. The ovicelled zooecia are wider; their aperture is large (0.20 by 0.25 mm) and ornamented with two large cardelles; the peristomice is semielliptical, transverse.

Measurements.—

$$\text{Aperture} \begin{cases} ha = 0.10 \text{ mm} \\ la = 0.15-0.16 \text{ mm} \end{cases} \quad \text{Zooecium} \begin{cases} Lz = 0.60-0.70 \text{ mm} \\ lz = 0.40-0.50 \text{ mm} \end{cases}$$

Occurrence.—Balcombian beds at Muddy Creek, Victoria.

Holotype.—U.S.N.M. no. 85701.

EMBALLOTHECA GRANULATA, n. sp.

Plate 5, fig. 7

Description.—The zoarium is bilamellar. The zooecia are distinct, separated by a deep furrow, rectangular, elongated, a little contracted behind; the frontal is convex, covered with *granules* separated by very small tremopores. The aperture is semielliptical, transverse; the proximal border is formed by a wide convex mucron; there are two cardelles, long, thin, oblique, oriented proximally; the peristome is thin, smooth, hardly salient. The ovicell is unknown.

Measurements.—

$$\text{Aperture} \begin{cases} ha = 0.10 \text{ mm} \\ la = 0.18-0.20 \text{ mm} \end{cases} \quad \text{Zooecium} \begin{cases} Lz = 0.75-0.90 \text{ mm} \\ lz = 0.40-0.50 \text{ mm} \end{cases}$$

Number of zooecia in 4 mm^2 , 13, 14.

Occurrence.—Kalimman beds (bore no. 1, depth 110 feet) at Lakes Entrance, Victoria.

Holotype.—U.S.N.M. no. 85703.**EMBALLOTHECA ANGUSTATA, n. sp.**

Plate 5, fig. 8

Description.—The zoarium is bilamellar. The zooecia are distinct, separated by a thin thread placed at the bottom of a furrow, much elongated, *very narrow*, of cylindrical aspect; the frontal is convex, finely granulose and perforated by a large number of very small tremopores. The aperture is semicircular; the proximal border is formed by a wide convex mucron presenting a small circular depression on the zooecial axis; the peristome is incomplete, smooth, salient. There are two thin cardelles.

Measurements.—

$$\text{Aperture} \begin{cases} ha = 0.15 \text{ mm} \\ la = 0.17 \text{ mm} \end{cases} \quad \text{Zooecium} \begin{cases} Lz = 0.80-0.95 \text{ mm} \\ lz = 0.35 \text{ mm} \end{cases}$$

Number of zooecia in 4 mm^2 , 13.

Occurrence.—Janjukian beds at Orbost, Gippsland, Victoria.

Holotype.—U.S.N.M. no. 85704.**SCHIZOPORELLA Hincks, 1877****SCHIZOPORELLA ORBICULIFERA, n. sp.**

Plate 6, fig. 9

Description.—The zoarium is free, cylindrical, formed of four or five longitudinal series of zooecia. The zooecia are distinct, separated by a very salient thread, lozenge-shaped, very much elongated, large;

the frontal is convex, formed by a granular tremocyst with very small and numerous pores. The aperture is semielliptical, transverse; the proximal border bears a small rounded sinus; the peristome is complete, thin, smooth, little salient and separated from the separating thread only by a small furrow. The avicularium is small, *orbicular*, a little salient, always placed in one of the two lateral angles. The ovicell is large, globular, placed on the distal zooecium, hyperstomial, closed by the operculum; its surface is granular. The aperture of the ovicelled zooecia is larger.

Measurements.—

Aperture $\left\{ \begin{array}{l} ha=0.10-0.12 \text{ mm} \\ la=0.15 \text{ mm} \end{array} \right.$ Zooecium $\left\{ \begin{array}{l} Lz=0.90-1.00 \text{ mm} \\ lz=0.50-0.60 \text{ mm} \end{array} \right.$

Occurrence.—Janjukian beds at Anticline Creek, Dartmoor, Victoria.

Cotypes.—U.S.N.M. no. 85856.

SCHIZOPORELLA MACGILLIVRAYI, n. sp.

Plate 9, fig. 5

Schizoporella phymatopora MacGillivray (pars), Trans. Roy. Soc. Victoria, vol. 4, p. 80, pl. 11, fig. 3 (not 2), 1895.

Measurements.—

Aperture $\left\{ \begin{array}{l} ha=0.16 \text{ mm} \\ la=0.16-0.17 \text{ mm} \end{array} \right.$ Zooecium $\left\{ \begin{array}{l} Lz=0.77-0.85 \text{ mm} \\ lz=0.44-0.55 \text{ mm} \end{array} \right.$

Structure.—It is quite impossible that figures 3 and 2 of MacGillivray refer to the same species, for there is a great difference in the apertural dimensions. We consider figure 3 as representing a distinct species, *S. macgillivrayi*, very close to *S. alata*, and characterized by its orbicular aperture (not transverse), its rounded proximal sinus, absence of avicularia, and zooecia frequently axially disarranged.

Occurrence.—Balcombian beds at Muddy Creek, Victoria.

Holotype.—U.S.N.M. no. 85859.

SCHIZOPORELLA TENUILAMELLOSA, n. sp.

Plate 9, fig. 4

Description.—The zoarium is bilamellar; the fronds are flat, broad, and *very thin*. The zooecia are distinct, separated by a shallow furrow, rectangular, very long; the frontal is a little convex, smooth, bordered with about 10 large areolar pores. The aperture in transverse aspect is semielliptical; its proximal border is rectilinear and notched by a very small triangular sinus. Each zooecium bears on the median longitudinal axis of the frontal two very small avicularia; the first

is orbicular and placed a short distance from the apertural sinus; the second placed a little lower, is transverse, very thin, triangular. The ovicell is unknown.

Measurements.—

Aperture $\left\{ \begin{array}{l} ha = 0.10 \text{ mm} \\ la = 0.09-0.10 \text{ mm} \end{array} \right.$ Zooecium $\left\{ \begin{array}{l} Lz = 0.65-0.75 \text{ mm} \\ lz = 0.35-0.44 \text{ mm} \end{array} \right.$
 Number of zooecia in 4 mm^2 , 15, 16.

Occurrence.—Balcombian beds at Muddy Creek, Victoria.

Holotype.—U.S.N.M. no. 85860.

SCHIZOPORELLA PUSTULOSA, n. sp.

Plate 5, fig. 6

Description.—The zoarium is bilamellar with very narrow fronds. The zooecia are distinct, separated by a furrow, at the bottom of which is a very thin thread, elongated, somewhat oval; the frontal is a pleurocyst ornamented with seven to nine large granules or *pustules* and bordered by six very small areolar pores much separated from each other. The aperture is small, oval, a little oblique, embedded; the proximal sinus is very wide, and triangular; the peristome is very thin, nonsalient and bears four very small and much scattered tuberosities. Ovicell unknown.

Measurements.—

Aperture $\left\{ \begin{array}{l} ha = 0.10 \text{ mm} \\ la = 0.09 \text{ mm} \end{array} \right.$ Zooecium $\left\{ \begin{array}{l} Lz = 0.60-0.75 \text{ mm} \\ lz = 0.35 \text{ mm} \end{array} \right.$
 Number of zooecia in 4 mm^2 , 22-24.

Occurrence.—Janjukian, Aire Coastal beds, Victoria.

Holotype.—U.S.N.M. no. 85862.

SCHIZOPORELLA ARCANA, n. sp.

Plate 9, fig. 9

Description.—The zoarium is unilamellar. The frontal is not entirely perforated; the cells are surrounded with an olocystic band and bear below the aperture a macula of the same nature.

Occurrence.—Balcombian beds at Muddy Creek, Victoria.

Cotypes.—U.S.N.M. no. 85857.

SCHIZOPORELLA CLYPEATA, n. sp.

Plate 6, fig. 11

Description.—The zoarium is unilamellar. The zooecia are distinct, separated by a very thin thread, very large, nonsymmetrical, much

elongated, of little width; the frontal is little convex and formed by a large pleurocyst forming a smooth, elliptical cushion or shield; it is surrounded laterally by a double row of areolar pores and proximally by four rows of scattered pores. The aperture is oval, axially disarranged, terminated by a narrow proximal sinus rounded at its extremity. A small oral avicularium, adjacent to the peristome is placed between the anter and the sinus. Another small zoecial avicularium is placed laterally on the exterior line of areolar pores and a little below the level of the proximal sinus. Ovicell unknown.

Measurements.—

$$\text{Aperture} \begin{cases} ha = 0.26 \text{ mm} \\ la = 0.20 \text{ mm} \end{cases} \quad \text{Zooecia} \begin{cases} Ls = 1.40 \text{ mm} \\ ls = 0.65-0.75 \text{ mm} \end{cases}$$

Number of zooecia in 4 mm^2 , 6.

Occurrence.—Janjukian beds at Anticline Creek, Dartmoor, Victoria.

Holotype.—U.S.N.M. no. 85855.

Subfamily EXOCHELLINAE Bassler, 1935

BATHOSELLA Canu and Bassler, 1917

BATHOSELLA LATICELLA, n. sp.

Plate 9, fig. 2

Description.—The zoarium is free, bilamellar, with narrow fronds. The zooecia are distinct, separated by a very deep furrow, elongated, globular, *very wide*; the frontal is rather convex, finely granular, pierced laterally by two or three pores. The aperture is large, elliptical, transverse, somewhat oblique; the peristome is thick, a little salient, smooth. On one zoecial margin there is a small triangular avicularium with pivot oriented distally.

Measurements.—

$$\text{Aperture} \begin{cases} ha = 0.14 \text{ mm} \\ la = 0.20 \text{ mm} \end{cases} \quad \text{Zooecium} \begin{cases} Ls = 0.85 \text{ mm} \\ ls = 0.50-0.55 \text{ mm} \end{cases}$$

Number of zooecia in 4 mm^2 , 12.

Occurrence.—Janjukian, Aire Coastal beds, Victoria.

Holotype.—U.S.N.M. no. 60211.

BATHOSELLA BULBOSA, n. sp.

Plate 9, fig. 1

Description.—The zoarium is free, bilamellar, of narrow fronds. The zooecia are distinct, separated by a deep furrow, large, elongated *bulbous*; the frontal is very convex, margined by two to four large

pores, and formed by a granular pleurocyst. The aperture is large, elliptical, transverse, oblique, often mucronated; the peristome is thick and granulated like the frontal. Laterally, on the transverse median axis of the zooecium and symmetrically arranged, there are two small elliptical, salient avicularia with pivot, oriented proximally.

Measurements.—

Aperture $\left\{ \begin{array}{l} ha = 0.12-0.15 \text{ mm} \\ la = 0.20 \text{ mm} \end{array} \right.$ Zooecia $\left\{ \begin{array}{l} Ls = 0.75-0.80 \text{ mm} \\ ls = 0.40-0.45 \text{ mm} \end{array} \right.$

Number of zooecia in 4 mm^2 , 14 or 15.

Occurrence.—Janjukian, Aire Coastal beds, Victoria.

Holotype.—U.S.N.M. no. 60205.

EXOCELLA Jullien, 1888

EXOCELLA GRANDIS, n. sp.

Plate 9, fig. 3

Description.—The zoarium is unilamellar. The zooecia are distinct, separated by a salient thread, large, elongated, hexagonal; the frontal is a granular pleurocyst, bordered by large areolar pores separated by short costules. The apertura is semielliptical; the peristome is thin and salient; a salient rectangular mucron hides the proximal border of the apertura. The ovicell is globular, convex, granular. The avicularium is transverse, thin, triangular, acuminate; it replaces an areolar pore.

Measurements.—

Apertura $\left\{ \begin{array}{l} ha = 0.15-0.17 \text{ mm} \\ la = 0.15-0.17 \text{ mm} \end{array} \right.$ Zooecia $\left\{ \begin{array}{l} Ls = 0.75-0.90 \text{ mm} \\ ls = 0.50-0.70 \text{ mm} \end{array} \right.$

Occurrence.—Balcombian beds at Muddy Creek, Victoria.

Holotype.—U.S.N.M. no. 85711.

DIDYMOSELLA Canu and Bassler, 1917

DIDYMOSELLA CLYPEATA, n. sp.

Plate 9, figs. 7, 8

Description.—The zoarium is unilamellar, free; the fronds are narrow, bifurcated, formed of about seven longitudinal rows of cells; the dorsal is covered with an epicalcification hiding the form of the zooecia and on which there are deep longitudinal furrows. The zooecia are little distinct, separated by shallow and inconstant furrows, long aliform; the frontal is convex, formed distally by a shield, and proximally by a tremocyst with large pores. The shield is large, broad, smooth, perforated by two large foramina; its distal portion

is arched and separated by a deep furrow with two calcified bands attached to the peristome. The large zooecial avicularium is triangular, with pivot; its beak is oriented exteriorly toward the nearest zooecial margin. The peristomice is semielliptical, transverse, with somewhat concave proximal border; the peristome is thin, salient, ornamented with four spines, two of which are proximal.

Measurements.—

$$\text{Peristomice} \begin{cases} hp = 0.14 \text{ mm} \\ lp = 0.21 \text{ mm} \end{cases} \quad \text{Zooecium} \begin{cases} Lz = 0.72-0.75 \text{ mm} \\ lz = 0.47-0.50 \text{ mm} \end{cases}$$

Number of zooecia in 4 mm^2 , 12.

Occurrence.—Muddy Creek (Balcombian), Anticline Creek, Dartmoor and Corio Bay, Geelong, Mount Gambier, etc., (Janjukian), Victoria.

Holotype.—U.S.N.M. nos. 85684-85688.

ESCHAROIDES Milne-Edwards, 1836

ESCHAROIDES ERECTA, n. sp.

Plate 9, fig. 6

Description.—The zoarium is free, erect, cylindrical, formed of four longitudinal series of zooecia. The zooecia are large, very elongated, somewhat aliform distally; the frontal is very convex, formed by a finely granulated pleurocyst, bordered by numerous areolar pores which separate very short costules; its distal portion is terminated by two large avicularian mucrons, very long, erect, hiding entirely the aperture and the locella. On each side of the aperture there is a small transverse, triangular avicularium in which the chamber is large, triangular, perforated in its middle by a small pore (radicell?).

$$\text{Measurements.}—\text{Zooecium} \begin{cases} Lz = 1.15-1.25 \text{ mm} \\ lz = 0.60 \text{ mm} \end{cases}$$

Occurrence.—Janjukian beds at Gellibrand, Torquay, Mount Gambier, and Boggy Creek, Victoria.

Holotype.—U.S.N.M. nos. 85819, 85847.

Subfamily MICROPORELLAE Canu and Bassler, 1917

MICROPORELLA Hincks, 1877

MICROPORELLA CAILLETI, n. sp.

Plate 9, fig. 10

Description.—The zoarium is unilamellar. The zooecia are distinct, separated by a deep furrow, hexagonal, wide, very little elongated; the frontal is convex and is a finely granulated tremocyst perforated

by a large number of very small pores. The ascopore is transverse, elliptical or crescentic, salient and almost adjacent to the aperture. The aperture is semielliptical with a straight, transverse, proximal border; the peristome is distal, salient, thick, ornamented with several flat, short spines. The avicularium is lateral, large, transverse, triangular, with beak pointed and oriented exteriorly, placed at the side or a little below the ascopore; it surmounts a triangular chamber, salient, convex, covered by tremopores. The ovicell is hyperstomial, closed by the operculum, large, globular, of the same nature as the frontal.

Measurements.—

Aperture $\left\{ \begin{array}{l} ha = 0.07 \text{ mm} \\ la = 0.15 \text{ mm} \end{array} \right.$ Zoocia $\left\{ \begin{array}{l} Lz = 0.55 \text{ mm} \\ lz = 0.40-0.55 \text{ mm} \end{array} \right.$
 Number of zoecia in 4 mm^2 , 16.

Occurrence.—Balcombian beds at Muddy Creek, Victoria.

Holotype.—U.S.N.M. no. 85791.

FENESTRULINA Jullien, 1888

FENESTRULINA PRAETEXTA, n. sp.

Plate 9, fig. 11

Description.—The zoarium is free, bilamellar, bifurcated; the fronds are narrow and flabellate. The zoecia are distinct, bordered by a thin thread surmounting a large salient smooth cushion, triangular in section, much elongated, rectangular somewhat narrowed behind; the frontal is little convex, bordered laterally by areolar pores and proximally with some tremopores; it bears on the longitudinal axis a large orbicular or crescentic ascopore much removed from the aperture. The aperture is semielliptical, transverse, the poster being simply concave. Ovicell unknown.

Measurements.—

Aperture $\left\{ \begin{array}{l} ha = 0.09 \text{ mm} \\ la = 0.13 \text{ mm} \end{array} \right.$ Zoecium $\left\{ \begin{array}{l} Lz = 0.80 \text{ mm} \\ lz = 0.36-0.40 \text{ mm} \end{array} \right.$
 Number of zoecia in 4 mm^2 , 18.

Occurrence.—Janjukian beds at Flinders, Victoria.

Holotype.—U.S.N.M. no. 85720.

Subfamily HIPPOPORAE Canu and Bassler, 1917

HIPPOMENELLA Canu and Bassler, 1917

HIPPOMENELLA PARVIPOROSA, n. sp.

Plate 7, fig. 2

Description.—The zoarium is unilamellar and attached to fragments of bryozoa. The zoecia are distinct, separated by a rather deep

furrow, elongated, vaguely lozenge-shaped, enlarged on the transverse axis; the frontal is convex, smooth, bordered by a double row of numerous very small areolar pores separated by small radial costules. The aperture is oval, elongated; the anter is separated by two cardelles descending from the poster, which is smaller. The frontal avicularia are small, triangular, with pivot; the beak is salient, pointed, oriented proximally; they are placed indistinctly on the first or on the second row of pores; there are two or three on the same frontal.

Measurements.—

$$\text{Aperture} \begin{cases} ha = 0.20 \text{ mm} \\ la = 0.16 \text{ mm} \end{cases} \quad \text{Zoocium} \begin{cases} Ls = 0.75-0.95 \text{ mm} \\ ls = 0.60 \text{ mm} \end{cases}$$

Number of zoecia in 4 mm^2 , 10.

Occurrence.—Balcombian beds at Muddy Creek, Victoria.

Holotype.—U.S.N.M. no. 85755.

HIPPOMENELLA RARIROSTRATA, n. sp.

Plate 7, fig. 1

Description.—The zoarium is unilamellar. The zoecia are distinct, separated by a deep furrow, elliptical, little elongated; the frontal is very convex, smooth, bordered by a double row of areolar pores. The aperture is large, semielliptical, elongated, with convex proximal border, without peristome. The ovicell is large, buried in the distal zoecium, hyperstomial, closed by the operculum; its frontal is decorated with numerous radial lines of small pores separated from each other by very salient costules; the latter are arrested at the center by a large smooth, triangular area and a smooth, curved pad serves as the proximal limit. The frontal avicularia are rare, a single one, often absent, to a zoecium, small, triangular, placed very inferiorly on the inner line of areolar pores; they have a pivot and the beak is oriented proximally.

Measurements.—

$$\text{Aperture} \begin{cases} ha = 0.18-0.20 \text{ mm} \\ la = 0.16-0.18 \text{ mm} \end{cases} \quad \text{Zoocium} \begin{cases} Ls = 0.66 \text{ mm} \\ ls = 0.45 \text{ mm} \end{cases}$$

Number of zoecia in 4 mm^2 , 8.

Occurrence.—Balcombian beds at Muddy Creek, Victoria.

Holotype.—U.S.N.M. no. 85753.

HIPPOMENELLA MAGNA, n. sp.

Plate 8, fig. 13

Description.—The zoarium is unilamellar. The zoecia are distinct, separated by a deep furrow, fusiform, *large*, very elongated; the frontal is convex and formed by a reduced pleurocyst, elliptical, elongated, bordered by two or three rows of lateral areolar pores and by

four or five rows of proximal ones. In the inner row the areolar pores are small, numerous, and separated by short radial costules. The aperture is neatly hippoporiform; two long, oblique cardelles, placed low, separate a large orbicular anter from a poster smaller but wider and in which the proximal border is straight or a little convex; no salient peristome. There is only a single lateral avicularium to a zooecium; it is placed a little above the transverse, median zooecial axis; it is small, oval, oblique, with beak oriented exteriorly.

Measurements.—

$$\text{Aperture} \begin{cases} ha = 0.22 \text{ mm} \\ la = 0.29 \text{ mm} \end{cases} \quad \text{Zooecium} \begin{cases} Ls = 1.10-1.65 \text{ mm} \\ ls = 0.55-0.65 \text{ mm} \end{cases}$$

Number of zooecia in 4 mm^2 , 6.

Occurrence.—Janjukian beds at Torquay, 15 miles south of Geelong, Victoria (bore no. 1 at depth of 160 feet).

Holotype.—U.S.N.M. no. 85754.

HIPPOMENELLA VERMICULARIS, n. sp.

Plate 8, fig. 3

Description.—The zoarium is unilamellar, the zooecia are distinct, separated by a very deep furrow, elliptical, very short, swollen; the frontal is very convex and formed by a smooth pleurocyst, surrounded by four or five rows of large areolar pores. The aperture of the ovicelled zooecia is rectangular, a little transverse, narrowed in the inferior third. The proximal border is convex. The ovicell is enormous, globular, embedded in the distal zooecium perforated by large scattered pores and richly decorated by salient vermiform ridges. There are two avicularia symmetrically arranged on the transverse median axis of each zooecium and on the inner line of areolar pores; they are small, triangular, oblique; their beak is salient and is oriented exteriorly and proximally.

Measurements.—

$$\text{Aperture} \begin{cases} ha = 0.15-0.20 \text{ mm} \\ la = 0.21 \text{ mm} \end{cases} \quad \text{Zooecium} \begin{cases} Ls = 0.75 \text{ mm} \\ ls = 0.15 \text{ mm} \end{cases}$$

(Ovicelled zooecia)

Number of zooecia in 1 mm^2 , 3.

Occurrence.—Balcombian beds at Muddy Creek, Victoria.

Holotype.—U.S.N.M. no. 85752.

HIPPOPORELLA Canu, 1917

HIPPOPORELLA TESTU, n. sp.

Plate 8, fig. 4

Description.—The zoarium is unilamellar. The zooecia are distinct, separated by a deep furrow, large, elongated; the frontal is very

convex, smooth, bordered by a line of small areolar pores much scattered. The aperture is large, transverse, having the form of a dish cover with concave proximal border; the peristome is incomplete, very little salient, thin, and bears six spines; the two proximal spines correspond to a slight lateral contraction of the aperture. The ovicell is large, globular, not closed by the operculum. A small oral avicularium placed on the line of the pores adjacent to the peristome is visible on one side of the aperture.

Measurements.—

Aperture $\left\{ \begin{array}{l} ha=0.24 \text{ mm} \\ la=0.30-0.33 \text{ mm} \end{array} \right.$ Zooecium $\left\{ \begin{array}{l} Lz=1.00 \text{ mm} \\ lz=0.60 \text{ mm} \end{array} \right.$

Occurrence.—Balcombian beds at Muddy Creek, Victoria.

Holotype.—U.S.N.M. no. 85760.

HIPPOMONAVELLA Canu and Bassler, 1934

HIPPOMONAVELLA ACUTIROSTRIS, n. sp.

Plate 7, fig. 5

Description.—The zoarium is incrusting. The zooecia are distinct, separated by a salient thread, polygonal, elongated; the frontal is little convex, smooth, bordered by very small and numerous pores. The aperture is suborbicular, very little elongated; the two cardelles are thin, salient, median; the peristome is terminal, thin, little salient. The avicularium is thin, triangular, elongated, almost adjacent to the peristome; the beak is very sharp and salient. Ovicell unknown.

Measurements.—

Aperture $\left\{ \begin{array}{l} ha=0.14 \text{ mm} \\ la=0.13 \text{ mm} \end{array} \right.$ Zooecium $\left\{ \begin{array}{l} Lz=0.72 \text{ mm} \\ lz=0.47 \text{ mm} \end{array} \right.$

Number of zooecia in 4 mm², 13.

Occurrence.—Balcombian beds at Muddy Creek, Victoria.

Holotype.—U.S.N.M. no. 85757.

Family SMITTINIDAE Levinsen, 1909

SMITTINA Norman, 1903

SMITTINA PERFORATA, n. sp.

Plate 7, fig. 3

Description.—The zoarium is unilamellar. The zooecia are distinct, separated by a very small furrow, elongated, elliptical; the frontal is convex, marginated by a salient pad, convex and formed by a smooth pleurocyst surrounded by a line of six to eight pairs of large areolar pores separated by very short costules. The aperture is sub-

orbicular; its proximal border bears a wide lyrule, salient and flat. In front of the aperture on the median longitudinal axis of the zooecium, there is a large orbicular perforation corresponding to an avicularium of the same form.

Measurements.—

Aperture $\left\{ \begin{array}{l} ha = 0.14 \text{ mm} \\ la = 0.12 \text{ mm} \end{array} \right.$ Zooecium $\left\{ \begin{array}{l} Lz = 0.63 \text{ mm} \\ lz = 0.41 \text{ mm} \end{array} \right.$

Number of zooecia in 4 mm^2 , 13.

Occurrence.—Balcombian beds at Muddy Creek, Victoria.

Holotype.—U.S.N.M. no. 85868.

SMITTINA (?) PARVIOVICELLOSA, n. sp.

Plate 7, fig. 4

Description.—The zoarium is free, bilamellar, with wide, flat, or undulated fronds. The zooecia are distinct, separated by a salient thread, much elongated, fusiform; the frontal is convex, surrounded by small and very numerous areolar pores and formed by a rugose pleurocyst. The aperture is elliptical, transverse, without peristome. The ovicell is very small, globular, smooth, placed on the distal zooecium. The oral avicularium is small, adjacent to the aperture, elliptical, with pivot, placed on the median longitudinal axis of the zooecium.

Measurements.—

Aperture $\left\{ \begin{array}{l} ha = 0.10 \text{ mm} \\ la = 0.13 \text{ mm} \end{array} \right.$ Zooecium $\left\{ \begin{array}{l} Lz = 1.00-1.24 \text{ mm} \\ lz = 0.30-0.36 \text{ mm} \end{array} \right.$

Number of zooecia in 4 mm^2 , 12.

Occurrence.—Janjukian beds at Orbost, Gippsland, Victoria.

Holotype.—U.S.N.M. no. 85869.

MUCRONELLA Hincks, 1880

MUCRONELLA ELONGATA, n. sp.

Plate 7, fig. 6

Description.—The zoarium is free, cylindrical, rectilinear, of small diameter (0.80 mm). The zooecia are distinct, separated by a small, little salient thread, very long, narrow, fusiform. The frontal is convex, smooth, surrounded by a row of 14 to 16 pairs of very small areolar pores. The peristome is salient, thin, elliptical, elongated; its proximal border bears a small mucron inclined in the peristomie; the aperture is visible at the bottom of the peristomie. The ovicell is large, salient, globular, placed on the distal zooecium, smooth, hyperstomial, opening in the peristomie.

Measurements.—

$$\text{Peristomice} \begin{cases} hp = 0.15 \text{ mm} \\ lp = 0.12 \text{ mm} \end{cases} \quad \text{Zooecium} \begin{cases} Ls = 1.15-1.25 \text{ mm} \\ ls = 0.30-0.35 \text{ mm} \end{cases}$$

Occurrence.—Janjukian beds at Anticline Creek, Dartmoor, Victoria.

Cotypes.—U.S.N.M. no. 85806.

SMITTINELLA Canu and Bassler, 1934**SMITTINELLA MAGNA**, n. sp.

Plate 8, fig. 7

Description.—The zoarium is bilamellar with very narrow fronds. The zooecia are distinct, separated by a salient thread, *large*, rectangular, much elongated; the frontal is convex and perforated by three or four longitudinal rows of tremopores. The lateral zooecia are wider than the axial zooecia. The peristomice is suborbicular or elliptical; the peristome is salient, thin, sharp, complete, with a small proximal spiramen. The ovicell is large, globular, marginated, finely granulated with a large porous area.

Measurements.—

$$\text{Peristomice} \begin{cases} hp = 0.10-0.11 \text{ mm} \\ lp = 0.10-0.11 \text{ mm} \end{cases} \quad \text{Zooecium} \begin{cases} Ls = 0.75-0.90 \text{ mm} \\ ls = 0.25 \text{ mm (axial)} \quad 0.30 \text{ mm (lateral)} \end{cases}$$

Number of zooecia in 1 mm^2 , 3.

Occurrence.—Janjukian beds at Anticline Creek, Dartmoor, Victoria.

Holotype.—U.S.N.M. no. 86957.

SMITTINELLA OSIFERA, n. sp.

Plate 7, fig. 10

Description.—The zoarium is bilamellar with narrow fronds. The zooecia are distinct, separated by a small salient thread, somewhat fusiform, elongated; the frontal is convex, finely granulose and perforated by some scattered pores. The aperture is elliptical, transverse, with a very small proximal sinus; the peristome is complete, very thin, scarcely salient. There is a broad lyrule and two small cardelles. The ovicell is very large, salient, globular with broad margin and a very fragile orbicular area; the orifice is very large, transverse, of the form of an open mouth, with a proximal spiramen.

Measurements.—

$$\text{Aperture} \begin{cases} ha = 0.12 \text{ mm} \\ la = 0.17 \text{ mm} \end{cases} \quad \text{Zooecium} \begin{cases} Lz = 0.70-0.80 \text{ mm} \\ lz = 0.30 \text{ mm} \end{cases}$$

Number of zooecia in 4 mm^2 , 20-23.

Occurrence.—Balcombian beds at Muddy Creek, Victoria.

Cotypes.—U.S.N.M. no. 85871.

SMITTINELLA MAGNIPOROSA, n. sp.

Plate 7, fig. 8

Description.—The zoarium is bilamellar with narrow, flat fronds. The zooecia are distinct, separated by a large salient thread, rectangular, short, elongated; the frontal is somewhat convex and perforated by a dozen large pores. The aperture is oval, a little elongated; the proximal sinus is more or less wide, and always rounded; the lyrule and the cardelles are very fragile. The peristome is wide but not salient. The ovicell is large, globular with a central area orbicular and fragile. The peristomice of the ovicelled zooecia is large, semi-circular, transverse; the spiramen is large, salient, constant.

Measurements.—

$$\text{Aperture} \begin{cases} ha = 0.12-0.15 \text{ mm} \\ la = 0.12 \text{ mm} \end{cases} \quad \text{Zooecium} \begin{cases} Lz = 0.50-0.55 \text{ mm} \\ lz = 0.22-0.25 \text{ mm} \end{cases}$$

Number of zooecia in 4 mm^2 , 25-30.

Occurrence.—Balcombian beds at Muddy Creek, Victoria.

Holotype.—U.S.N.M. no. 85870.

PORELLA Gray, 1848**PORELLA TUBEROSA**, n. sp.

Plate 7, fig. 7

Description.—The zoarium is bilamellar. The zooecia are distinct, separated by a salient thread, elongated, fusiform; the frontal is convex, covered by tremopores separated by *tuberosities*. The aperture is suborbicular; a hollow, rounded proximal indentation serves as orifice for an orbicular avicularium opening into the peristomice; the chamber of this avicularium is large, smooth, and forms in front of the aperture a large gibbosity. The peristome is thin, little salient and forms a separating thread. The ovicell is very large; a small axial ridge separates it into two compartments. The ovicelled zooecia are broader; their aperture is enormous (0.15 by 0.25 mm).

Measurements.—

Aperture $\left\{ \begin{array}{l} ha = 0.15 \text{ mm} \\ la = 0.15-0.17 \text{ mm} \end{array} \right.$ Zooecium $\left\{ \begin{array}{l} Lz = 0.75-1.00 \text{ mm} \\ lz = 0.29-0.34 \text{ mm} \end{array} \right.$
 Number of zooecia in 4 mm^2 , 15.

Occurrence.—Balcombian beds at Muddy Creek, Victoria.

Holotype.—U.S.N.M. no. 85843.

PORELLA CYLINDROROSTRIS, n. sp.

Plate 7, fig. 9

Description.—The zoarium is bilamellar. The zooecia are distinct, separated by a thick thread, very salient, smooth; they are elongated, polygonal; the frontal is little convex and perforated with large expanded tremopores. The peristome is thick, smooth, salient, covering proximally the avicularian chamber; the peristomic is elliptical and transverse or suborbicular; into the peristomic opens a large cylindrical avicularium, little salient, in which the orifice (invisible) is perpendicular to the apertural plane. The apertural chamber is large and forms a large convexity, salient, smooth, in front of the aperture. The ovicell is large, convex, margined, with a fragile orbicular area; it opens into the peristomic.

Measurements.—

Peristomic $\left\{ \begin{array}{l} hp = 0.13 \text{ mm} \\ lp = 0.17 \text{ mm} \end{array} \right.$ Zooecium $\left\{ \begin{array}{l} Lz = 0.70-0.77 \text{ mm} \\ lz = 0.35-0.42 \text{ mm} \end{array} \right.$
 Number of zooecia in 1 mm^2 , 4.

Occurrence.—Janjukian beds at Torquay near Geelong, Victoria.

Holotype.—U.S.N.M. no. 85829.

PORELLA BACULINA, n. sp.

Plate 8, fig. 8

Description.—The zoarium is free, cylindrical, in the form of a baton. The zooecia are distinct, separated by a small salient thread, elongated, elliptical, large; the frontal is convex and perforated by numerous small tremopores. The peristome is salient, thick, smooth, complete; the peristomic is suborbicular; an elliptical avicularium is lodged in the proximal portion of the peristomic.

Measurements.—

Peristomic $\left\{ \begin{array}{l} hp = 0.22-0.25 \text{ mm} \\ lp = 0.25 \text{ mm} \end{array} \right.$ Zooecium $\left\{ \begin{array}{l} Lz = 1.10 \text{ mm} \\ lz = 0.50-0.55 \text{ mm} \end{array} \right.$

Occurrence.—Janjukian beds at Mitchell River, Bairnsdale, Mount Gambier, and Boggy Creek, Victoria.

Cotypes.—U.S.N.M. nos. 85830-85832, 85848.

PORELLA OPERCULATA, n. sp.

Plate 8, fig. 6

Description.—The zoarium is free, cylindrical, long. The zooecia are indistinct with thick walls, very long; the frontal is convex and covered with numerous tubular tremopores. The peristome is thick, smooth, very little salient; the peristomic is elliptical, elongated; the peristomie is deep and formed by the thickening of the zooecial walls; it contains in the proximal portion a large oblique avicularium, triangular, with pivot; the beak is oriented distally; the proximal portion is free or closed by a suborbicular, calcareous operculum. The ovicell is large, salient, globular, ornamented with a double row of large pores separated by short radial costules.

Measurements.—

$$\text{Peristomic} \begin{cases} hp = 0.27-0.30 \text{ mm} \\ lp = 0.17-0.20 \text{ mm} \end{cases} \quad \text{Zooecium} \begin{cases} Lz = 1.10-1.20 \text{ mm} \\ lz = 0.50 (?) \text{ mm} \end{cases}$$

Occurrence.—Janjukian beds at Anticline Creek, Dartmoor, Victoria.

Cotypes.—U.S.N.M. no. 85842.

PORELLA EXCAVATA, n. sp.

Plate 7, fig. 11

Description.—The zoarium is free, bilamellar; the fronds are cylindrical, flabellate or lamellar and narrow, bifurcated; there are from one to seven longitudinal rows of zooecia on each branch. The zooecia are distinct, separated by a salient thread, elongated, rectangular; the frontal is flat and perforated with tremopores. The peristome is thin, salient, smooth; it is indented in the proximal portion by a linear sinus at the bottom of which there is a flat lyrule; the sinus is prolonged on the median axis of the zooecium by a small, linear excavation in which is placed a small, triangular, thin, elongated avicularium; the peristomic is orbicular and small. The ovicell is very small, globular, smooth.

Measurements.—

$$\text{Peristomic} \begin{cases} hp = 0.12 \text{ mm} \\ lp = 0.12 \text{ mm} \end{cases} \quad \text{Zooecium} \begin{cases} Lz = 0.75-0.90 \text{ mm} \\ lz = 0.25-0.30 \text{ mm} \end{cases}$$

Occurrence.—Janjukian beds at Anticline Creek, Dartmoor, Victoria.

Cotypes.—U.S.N.M. no. 85838.

PORELLA RHOMBOIDALIS PARVIAPERTURA, n. var.

Plate 8, fig. 1

Description.—The aperture is small. There is a small round avicularium supported on a flat wide lyrule. The separating threads of the zooecia are very salient and thin.

Measurements.—

$$\text{Peristomice} \begin{cases} hp = 0.20 \text{ mm} \\ lp = 0.18 \text{ mm} \end{cases} \quad \text{Zooecia} \begin{cases} Ls = 0.80-0.85 \text{ mm} \\ ls = 0.45 \text{ mm} \end{cases}$$

Number of zooecia in 4 mm^2 , 11.*Occurrence.*—Balcombian beds at Muddy Creek, Victoria.*Holotype.*—U.S.N.M. no. 85841.**PORELLA RHOMBOIDALIS CRASSIMARGINATA, n. var.**

Plate 8, fig. 2

Description.—The aperture is smaller than in the type. The small avicularium is borne on a flat lyrule. The separating threads of the zooecia are little salient and very thick.

Measurements.—

$$\text{Peristomice} \begin{cases} hp = 0.20 \text{ mm} \\ lp = 0.15 \text{ mm} \end{cases} \quad \text{Zooecium} \begin{cases} Ls = 0.80 \text{ mm} \\ ls = 0.50-0.60 \text{ mm} \end{cases}$$

Number of zooecia in 4 mm^2 , 10.*Occurrence.*—Balcombian beds at Muddy Creek, Victoria.*Holotype.*—U.S.N.M. no. 85844.**PALMICELLARIA Alder, 1864****PALMICELLARIA (?) MAGNA, n. sp.**

Plate 8, fig. 5

Description.—The zoarium is free, very long, filiform, formed of four longitudinal rows of zooecia opposed two by two. The zooecia are distinct, separated by a small, little salient thread, very large, very long, tubulose; the frontal is very convex, fibrous and garnished laterally with numerous small areolar pores. The peristome is very long, oblique, rather salient, thin, with an inferior lip more developed and convex; the peristomice is large, semielliptical, transverse. An oral avicularium with basal chamber large and globular opens laterally on the interior of the peristomie.

Measurements.—

$$\text{Peristomice} \begin{cases} hp = 0.20 \text{ mm} \\ lp = 0.30 \text{ mm} \end{cases} \quad \text{Zooecium} \begin{cases} Ls = 1.75-2.00 \text{ mm} \\ ls = 0.50 \text{ mm} \end{cases}$$

Occurrence.—Janjukian beds at Anticline Creek, Dartmoor, Victoria.

Cotypes.—U.S.N.M. no. 85818.

Family CELLEPORIDAE Busk, 1852

COSTAZIA Neviani, 1895

COSTAZIA CONVEXA, n. sp.

Plate 8, fig. 10

Haswellia producta (pars) MacGillivray, Trans. Roy. Soc. Victoria, vol. 4, p. 137, pl. 14, figs. 17, 18 (not 16 and 20), 1895.

Description.—The zoarium is cylindrical. The zoecia are distinct, poorly oriented, separated by a deep furrow; the frontal is very *convex*, almost tubular, smooth, surrounded by areolar pores, terminated by a mucron bearing an avicularium hiding a part of the aperture. The aperture is elliptical, somewhat elongated, without cardelles. The ovicell bears a perforated costulated area. The interzoecial avicularia are large, spathulated, enlarged at the beak, directed toward the base of the branches.

Occurrence.—Balcombian beds at Muddy Creek, Victoria.

Cotypes.—U.S.N.M. no. 85650.

Family PHYLACTELLIDAE Canu and Bassler, 1917

PHYLACTELLA Hincks, 1880

PHYLACTELLA CHAPMANI, n. sp.

Plate 8, fig. 9

Description.—The zoarium incrusts shells. The zoecia are distinct, separated by a furrow, somewhat elongated, rather swollen; the frontal is convex, smooth in appearance but perforated by extremely small pores and bordered by larger, more scattered pores. The aperture is small, semielliptical, with two cardelles and a lyrule visible only after suitably inclining the preparation; the peristome is salient, somewhat thick. The ovicell is recumbent, small, globular, smooth, not closed by the operculum, opening in front of the oral mucron.

Measurements.—

$$\text{Aperture} \begin{cases} ha = 0.07 \text{ mm} \\ la = 0.10 \text{ mm} \end{cases} \quad \text{Zoecia} \begin{cases} Lz = 0.60-0.90 \text{ mm} \\ lz = 0.50-0.75 \text{ mm} \end{cases}$$

Occurrence.—Balcombian beds at Muddy Creek and Janjukian beds at Torquay (bore, 160 feet deep), Victoria.

Holotype.—U.S.N.M. nos. 85820, 85821.

Family ORBITULIPORIDAE Canu and Bassler, 1923

STICHOPORINA Stoliczka, 1861

STICHOPORINA (?) PARVICAPITATA, n. sp.

Plate 8, fig. 11

Description.—The small fragments of this species in our collection are incomplete, and it is difficult to classify them. The ovicell which ought to be closed by the operculum, is small and analogous to that of *Batopora* and *Orbitulipora*. We do not know if there was a central pit. The zooecial walls are olocystal with two or three pores at the base. On the interior face the zooecia are hexagonal, and without doubt this species is indeed one of the Orbituliporidae.

Occurrence.—Balcombian beds at Muddy Creek, Victoria.

Cotypes.—U.S.N.M. no. 85882.

EXPLANATION OF PLATES

PLATE I

(All illustrations on this plate are magnified, $\times 20$)

	PAGE
FIG. 1. <i>Amphiblestrum grande</i> , new species.....	6
Ovicelled fragment of a unilamellar zoarium illustrating the large size of the cells, the granular gymnocyst and the apparent absence of avicularia.	
Balcombian beds at Muddy Creek, Victoria.	
FIG. 2. <i>Membranipora arcolata</i> , new species.....	3
Portion of the bilamellar zoarium showing the distal transverse avicularia and the polygonal interopesimal spaces.	
Janjukian, Aire Coastal beds, Victoria.	
FIG. 3. <i>Acanthodesia regularis</i> , new species.....	2
Portion of the free, subcylindrical branch exhibiting the regular form of the zooecia.	
Janjukian beds at Anticline Creek, Dartmoor, Victoria.	
FIG. 4. <i>Vincularia gigantea</i> , new species.....	3
Portion of the rodlike zoarium composed of unusually large zooecia.	
Janjukian beds at Anticline Creek, Dartmoor, Victoria.	
FIG. 5. <i>Allantopora confinis</i> , new species.....	6
A normal incrusting colony with zooecia bearing a large gymnocyst.	
Balcombian beds at Muddy Creek, Victoria.	
FIG. 6. <i>Floridinella australiensis</i> , new species.....	9
The narrow bilamellar zoarium exhibiting the characteristic condyles in the opesium.	
Balcombian beds at Muddy Creek, Victoria.	

	PAGE
FIG. 7. <i>Cribrilina crassicollis</i> , new species.....	15
Surface of the free cylindrical zoarium.	
Balcombian beds at Muddy Creek, Victoria.	
FIG. 8. <i>Stamenocella fusiformis</i> , new species.....	5
The free cylindrical zoarium celluliferous on all sides, exhibiting the fusiform zooecia and the orbicular avicularium.	
Balcombian beds at Muddy Creek, Victoria.	
FIG. 9. <i>Membraniporida asymmetrica</i> , new species.....	4
Ordinary and ovicelled zooecia of the bilamellar zoarium. The spiniform process on one side of the zooecium and the large transverse avicularium are shown.	
Balcombian beds at Muddy Creek, Victoria.	
FIG. 10. <i>Acanthodesia quadrilatera</i> , new species.....	2
The delicate subcylindrical zoarium of elongated rectangular zooecia with short spicules indenting the opesium.	
Balcombian beds at Muddy Creek, Victoria.	
FIGS. 11, 12. <i>Otionella circumdata</i> , new species.....	3
11. Lateral view of a small conical zoarium with large auriform primoseriate vibracula.	
12. Base of the same with radial lines and elliptical cavities each containing an avicularium around the periphery.	
Balcombian beds at Muddy Creek, Victoria.	

PLATE 2

(All illustrations on this plate are magnified, $\times 20$)

	PAGE
FIG. 1. <i>Ramphonotus</i> (?) <i>lamellosus</i> , new species.....	6
The bilamellar zoarium with normal and ovicelled zooecia and the narrow, transverse, triangular avicularium on the proximal part of the cryptocyst.	
Balcombian beds at Muddy Creek, Victoria.	
FIG. 2. <i>Arachnopusia linearis</i> , new species.....	8
The free bilamellar zoarium showing the aperture with its rectilinear proximal border and the perforated zooecial frontal.	
Balcombian beds at Muddy Creek, Victoria.	
FIG. 3. <i>Tremopora orbiculata</i> , new species.....	7
Portion of the unilamellar zoarium illustrating the orbicular zooecia, the two distal spines and the large lateral avicularium with a small one opposite it.	
Balcombian beds at Muddy Creek, Victoria.	
FIGS. 4, 5. <i>Tremopora staminis</i> , new species.....	7
4. Frontal of a unilamellar zoarial fragment exhibiting ovicells and some zooecia with the large frontal spine preserved.	
5. Dorsal of the same zoarium showing the fenestrae separating the connecting tubes, and the radicular pores.	
Balcombian beds at Muddy Creek, Victoria.	
FIG. 6. <i>Rectonychocella dimorphocella</i> , new species.....	9
Surface of the bilamellar colony with both ogival and membraniporoid cells.	
Balcombian beds at Muddy Creek, Victoria.	

	PAGE
FIGS. 7, 8. <i>Selenaria trifoliata</i> , new species.....	10
7. Outer margin of an orbicular zoarium showing the labial elevation of the opesium.	
8. Inner side of a specimen with single row of large pores to each rib.	
Balcombian beds at Muddy Creek, Victoria.	
FIG. 9. <i>Hincksina uniserialis</i> , new species.....	4
Part of the incrusting uniserial colony with one ovicelled zoecium.	
Janjukian beds at Corio Bay, Victoria.	
FIG. 10. <i>Thalamoporella elongata</i> , new species.....	12
The narrow bilamellar zoarium showing the much elongated zoecia and the inequality of the opesiules.	
Janjukian beds at Mitchell River, Victoria.	

PLATE 3

(All illustrations on this plate are magnified, $\times 20$)

	PAGE
FIGS. 1, 2. <i>Selenaria grandicella</i> , new species.....	11
1. Cellular side of the cupuliform zoarium showing the vibracula with distal concavity.	
2. Inner side of the same colony; the ribs have large lunularian pores.	
Balcombian beds at Muddy Creek, Victoria.	
FIG. 3. <i>Macropora quadriseriata</i> , new species.....	13
The quadriserial rod-shaped zoarium with zoecia ornamented by two polygonal areas at their base.	
Janjukian beds at Bairnsdale, Victoria.	
FIG. 4. <i>Siphonoporella filiparietis</i> , new species.....	11
Fragment of a unilamellar zoarium showing the thin mural rim, the narrow polypidial tube, and wide zoecia.	
Balcombian beds at Muddy Creek, Victoria.	
FIG. 5. <i>Siphonoporella livingstonei</i> , new species.....	11
Unilamellar zoarium with narrow zoecia and wide polypidial tubes.	
Balcombian beds at Muddy Creek, Victoria.	
FIGS. 6, 7. <i>Craspedozoum elongatum</i> , new species.....	14
6. Unilamellar, triserial fragment with the large avicularian chamber developed on the middle row.	
7. Dorsal of the fragment shown in figure 6.	
Balcombian beds at Muddy Creek, Victoria.	
FIGS. 8, 9. <i>Vibracella parvula</i> , new species.....	10
8. Cellular face of the small conical zoarium with large auriform primoserial vibracula and small hexagonal zoecia.	
9. Base of the same with lunularian pores on the ribs.	
Balcombian beds at Muddy Creek, Victoria.	
FIG. 10. <i>Cribrilina triseriata</i> , new species.....	16
Frontal view of the unilamellar triserial zoarium.	
Janjukian beds at Flinders, Victoria.	

	PAGE
FIG. 11. <i>Omoiosia elongata</i> , new species.....	14
A bilamellar zoarium showing the clongate zoecia of two kinds— normal and special.	
Balcombian beds at Muddy Creek, Victoria.	
FIG. 12. <i>Cribrilina terminata coronata</i> , new variety.....	16
View of unilamellar zoarium illustrating small avicularia on the peristome.	
Balcombian beds at Muddy Creek, Victoria.	

PLATE 4

(All illustrations on this plate are magnified, $\times 20$)

	PAGE
FIG. 1. <i>Macropora clarkei attenuata</i> , new variety.....	12
Portion of the bilamellar zoarium showing the characteristic separating furrow.	
Janjukian beds at Flinders, Victoria.	
FIG. 2. <i>Gigantopora hystrix</i> , new species.....	20
Surface of the cylindrical zoarium showing the short, broad zoecia and salient spines separating the tremopores.	
Balcombian beds at Muddy Creek, Victoria.	
FIG. 3. <i>Cellaria orbicularia</i> , new species.....	13
Portion of an ovicelled segment exhibiting the orbicular opesium.	
Janjukian beds at Anticline Creek, Dartmoor, Victoria.	
FIG. 4. <i>Cellaria attenuata</i> , new species.....	13
Extremity of a segment showing a joint of articulation at the end, a large broad avicularian zoecium, and the orifices of the ovicells.	
Balcombian beds at Muddy Creek, Victoria.	
FIG. 5. <i>Pachythecella unifasciata</i> , new species.....	17
Celluliferous side of the unilamellar bifurcated zoarium showing the large orbicular ascopore.	
Balcombian beds at Muddy Creek, Victoria.	
FIG. 6. <i>Gigantopora hexagonalis</i> , new species.....	20
Several zoecia of the unilamellar zoarium illustrating the coales- cence of the beaks of the two large lateral avicularia above the spiramen.	
Balcombian beds at Muddy Creek, Victoria.	
FIG. 7. <i>Ellisiniidra pyriformis</i> , new species.....	5
An example preserving the small hyperstomial ovicell.	
Balcombian beds at Muddy Creek, Victoria.	
FIG. 8. <i>Pachythecella armata</i> , new species.....	17
Bilamellar zoarium with orbicular aperture, small ascopore and the frontal of the zoecia covered with small shallow pores.	
Balcombian beds at Muddy Creek, Victoria.	
FIG. 9. <i>Petraliella</i> (?) <i>denticulata</i> , new species.....	10
Surface of the bilamellar zoarium showing the denticulated border of the peristomice.	
Balcombian beds at Muddy Creek, Victoria.	

	PAGE
FIG. 10. <i>Tubitrabecularia proditor</i> , new species.....	18
Portion of a complete ovicelled segment, showing trabeculae consolidating the peristomes, the ascopore, and the tubular peristomie and rounded peristomice.	
Balcombian beds at Muddy Creek, Victoria.	
FIG. 11. <i>Porina fissurifera</i> , new species.....	16
Portion of a narrow bilamellar zoarium with large frontal avicularia and slitlike ascopore.	
Balcombian beds at Muddy Creek, Victoria.	

PLATE 5

(All illustrations on this plate are magnified, $\times 20$)

	PAGE
FIG. 1. <i>Petraliella tractifera</i> , new species.....	19
Zoecial surface of the unilamellar orbicular zoarium.	
Balcombian beds at Muddy Creek, Victoria.	
FIG. 2. <i>Petraliella vultur</i> (Hincks, 1882) <i>aviculifera</i> , new variety.....	18
Surface of the unilamellar zoarium showing the numerous small avicularia and the salient avicularian umbo with its laterally placed mandible.	
Balcombian beds at Muddy Creek, Victoria.	
FIG. 3. <i>Gephyrophora bilamellaria</i> , new species.....	22
Surface of the bilamellar zoarium. The zooecia are without spiramen.	
Balcombian beds at Muddy Creek, Victoria.	
FIG. 4. <i>Spiroporina tenuis</i> , new species.....	22
View of the thin cylindrical bifurcated zoarium composed of zooecia separated by a thin crenulated thread.	
Janjukian beds at Corio Bay, Victoria.	
FIG. 5. <i>Gigantopora elongata</i> , new species.....	21
The cylindrical zoarium exhibiting the elongate zooecia and the crescentic spiramen.	
Janjukian beds at Gellibrand River, Victoria.	
FIG. 6. <i>Schizoporella pustulosa</i> , new species.....	30
Portion of the bilamellar zoarium showing the formation of the frontal pustules.	
Janjukian, Aire Coastal beds, Victoria.	
FIG. 7. <i>Emballothecha granulata</i> , new species.....	28
Fragment of the bilamellar zoarium exhibiting the rectangular zooecia with frontal covered by granules.	
Kalimnan beds at Lakes Entrance, Victoria (bore no. 1 at depth of 110 feet).	
FIG. 8. <i>Emballothecha angustata</i> , new species.....	28
Fragment of the bilamellar zoarium with very narrow, much elongated zooecia.	
Janjukian beds at Orbost, Gippsland, Victoria.	
FIG. 9. <i>Gigantopora minutiporosa</i> , new species.....	21
Celluliferous side of the unilamellar zoarium with the zoecial frontal pierced by minute pores.	
Janjukian beds at Flinders, Victoria.	

	PAGE
FIG. 10. <i>Gigantopora perforata</i> , new species.....	20
Surface of a narrow bilamellar ovicelled zoarium.	
Some zoecia have their peristomie complete and perforated by a small spiramen.	
Janjukian beds at Flinders, Victoria.	
FIG. 11. <i>Buffonellodes baculina</i> , new species.....	23
Cylindrical unovicelled zoarium formed of zoecia with convex smooth frontal.	
Balcombian beds at Muddy Creek, Victoria.	

PLATE 6

(All illustrations on this plate are magnified, $\times 20$)

	PAGE
FIG. 1. <i>Stephanosella scrxspinosa</i> , new species.....	23
Ovicelled incrusting zoarium with both zoecial and zoarial avicularia.	
Balcombian beds at Muddy Creek, Victoria.	
FIG. 2. <i>Chiastosella gibbera</i> , new species.....	25
Small fragment of a unilamellar zoarium illustrating the irregular indistinct zoecia and large falciform avicularia.	
Janjukian beds at Bairnsdale, Victoria.	
FIG. 3. <i>Chiastosella grandicella</i> , new species.....	26
Unilamellar zoarium exhibiting the very large zoecia and avicularia.	
Balcombian beds at Muddy Creek, Victoria.	
FIG. 4. <i>Chiastosella porosa</i> , new species.....	26
Surface of the unilamellar zoarium showing the convex porous frontal and transverse avicularia.	
Balcombian beds at Muddy Creek, Victoria.	
FIG. 5. <i>Schizobrachiella hexagonalis</i> , new species.....	24
Zoecia of the unilamellar zoarium bearing only a single well-developed avicularium.	
Balcombian beds at Muddy Creek, Victoria.	
FIG. 6. <i>Emballotheca inclinata</i> , new species.....	27
Surface of the broad bilamellar type specimen showing the enormous embedded ovicell and the semicylindrical nucron inclined in the aperture.	
Balcombian beds at Muddy Creek, Victoria.	
FIG. 7. <i>Dakaria crassocirca</i> , new species.....	24
Portion of the free, cylindrical zoarium.	
Janjukian beds at Bairnsdale, Victoria.	
FIG. 8. <i>Chiastosella lamellata</i> , new species.....	25
Wide frond of the lamellar zoarium exhibiting a group of ovicelled zoecia.	
Balcombian beds at Muddy Creek, Victoria.	
FIG. 9. <i>Schizoporella orbiculifera</i> , new species.....	28
Zoarium exhibiting a perforated ovicell.	
Janjukian beds at Anticline Creek, Dartmoor, Victoria.	

	PAGE
FIG. 10. <i>Chiastosella parviporosa</i> , new species.....	27
The unilamellar zoarium composed of large zooecia with the frontal ornamented by relatively small pores. Janjukian beds at Flinders, Victoria.	
FIG. 11. <i>Schizoporella clypeata</i> , new species.....	30
The unilamellar zoarium showing the disarranged apertures and the zooecial shield surrounded by areolar pores. Janjukian beds at Anticline Creek, Dartmoor, Victoria.	

PLATE 7

(All illustrations on this plate are magnified, $\times 20$)

	PAGE
FIG. 1. <i>Hippomenella rarirostrata</i> , new species.....	35
Fragment of a unilamellar ovicelled zoarium showing the radially ornamented ovicell with triangular area and few avicularia. Balcombian beds at Muddy Creek, Victoria.	
FIG. 2. <i>Hippomenella parviporosa</i> , new species.....	34
Unilamellar zoarial fragment attached to a fragment of bryozoan, showing the irregularity of position of the avicularia, the smooth frontal and the small areolar pores. Balcombian beds at Muddy Creek, Victoria.	
FIG. 3. <i>Smittina perforata</i> , new species.....	37
Fragment of the unilamellar zoarium showing the place of the large, orbicular, median avicularium. Balcombian beds at Muddy Creek, Victoria.	
FIG. 4. <i>Smittina</i> (?) <i>parvicicellose</i> , new species.....	38
Portion of a bilamellar ovicelled zoarium exhibiting the very small ovicells and much elongated zooecia. Janjukian beds at Orbost, Gippsland, Victoria.	
FIG. 5. <i>Hippomonavella acutirostris</i> , new species.....	37
Zoarium incomplete, incrusting, showing the formation of new cells and occurrence of the median avicularium. Balcombian beds at Muddy Creek, Victoria.	
FIG. 6. <i>Mucronella elongata</i> , new species.....	38
Example showing the very long zooecia with smooth frontal, one row of small areolar pores and small mucron. Janjukian beds at Anticline Creek, Dartmoor, Victoria.	
FIG. 7. <i>Porcella tuberosa</i> , new species.....	40
Surface of the bilamellar zoarium showing the frontal tuberosities and one ovicelled zooecium. Balcombian beds at Muddy Creek, Victoria.	
FIG. 8. <i>Smittinella magniporosa</i> , new species.....	40
Bilamellar ovicelled zoarium, showing the large frontal pores. Balcombian beds at Muddy Creek, Victoria.	
FIG. 9. <i>Porcella cylindrorostris</i> , new species.....	41
Portion of a bilamellar ovicelled frond showing the cylindrical avicularium covered by an expansion of the peristome. Janjukian beds at Bird Rock, Torquay, Victoria.	

PAGE

- FIG. 10. *Smittinella osifera*, new species..... 39
 Surface of an ovicelled zoarium exhibiting the very transverse outline of the ovicelled zoecia.
 Balcombian beds at Muddy Creek, Victoria.
- FIG. 11. *Porella excavata*, new species..... 42
 A wide frond in which the avicularia are quite visible in their excavations.
 Janjukian beds, Anticline Creek, Dartmoor, Victoria.

PLATE 8

(All illustrations on this plate are magnified, $\times 20$, unless otherwise indicated)

PAGE

- FIG. 1. *Porella rhomboidalis parviapertura*, new variety..... 43
 Unilamellar specimen with the characteristic small apertures.
 Balcombian beds at Muddy Creek, Victoria.
- FIG. 2. *Porella rhomboidalis crassimarginata*, new variety..... 43
 Unilamellar zoarium showing the zoecia surrounded by a broad margin.
 Balcombian beds at Muddy Creek, Victoria.
- FIG. 3. *Hippomenella vermicularis*, new species..... 36
 Fragment of a unilamellar zoarium showing the decoration of the ovicells and the two small zoecial avicularia.
 Balcombian beds at Muddy Creek, Victoria.
- FIG. 4. *Hippoporella testu*, new species..... 36
 Fragment of an ovicelled unilamellar zoarium. The large transverse aperture, six oral spines and small avicularium are shown.
 Balcombian beds at Muddy Creek, Victoria.
- FIG. 5. *Palmicellaria magna*, new species..... 43
 Fragments of the cylindrical zoarium, natural size, and an example on which the zoecia have two oral avicularia.
 Janjukian beds at Anticline Creek, Dartmoor, Victoria.
- FIG. 6. *Porella operculata*, new species..... 42
 Portion of the cylindrical zoarium with calcareous opercula and showing the true form of the oral avicularium.
 Janjukian beds, Anticline Creek, Dartmoor, Victoria.
- FIG. 7. *Smittinella magna*, new species..... 39
 Bilamellar ovicelled zoarium showing the large dimensions of the zoecia and the very porous frontal.
 Janjukian beds, Anticline Creek, Dartmoor, Victoria.
- FIG. 8. *Porella baculina*, new species..... 41
 Cylindrical zoarium with wide zoecia.
 Janjukian beds at Mitchell River, Bairnsdale, Victoria.
- FIG. 9. *Phylactella chapmani*, new species..... 44
 Portion of the incrusting zoarium illustrating the convex zoecial frontal, the lyrule and the recumbent ovicell.
 Balcombian beds at Muddy Creek, Victoria.
- FIG. 10. *Costazia convexa*, new species..... 44
 Cylindrical zoarium illustrating the small dimensions and the occurrence of an oral avicularium on an umbo.
 Balcombian beds at Muddy Creek, Victoria.

	PAGE
FIG. 11. <i>Stichoporina</i> (?) <i>parvicapitata</i> , new species.....	45
Zooeical surface of the unilamellar zoarium.	
Balcombian beds at Muddy Creek, Victoria.	
FIG. 12. <i>Trigonopora</i> (<i>Metrarabdotos</i>) <i>vermicularis</i> Maplestone, 1902.	
Surface of a narrow bilamellar zoarium received from Mr. Maplestone as <i>Trigonopora vermicularis</i> . The endozooeical ovicell, form of aperture and pleurocystal frontal with lateral areolae show this to be a true <i>Metrarabdotos</i> .	
Janjukian beds, Cape Otway, Victoria.	
FIG. 13. <i>Hippomenella magna</i> , new species.....	35
Fragment of the unilamellar zoarium illustrating the large zooecia, the arrangement of the areolar pores and form of aperture. At the middle there is a monstrous zooecium.	
Janjukian beds (Torquay bore no. 1, depth of 160 feet) 15 miles south of Geelong, Victoria.	

PLATE 9

(All illustrations on this plate are magnified, $\times 20$)

	PAGE
FIG. 1. <i>Bathosella bulbosa</i> , new species.....	31
Surface of the bilamellar zoarium with small elliptical avicularia and some zooecia closed by a calcareous operculum.	
Janjukian, Aire Coastal beds, Victoria.	
FIG. 2. <i>Bathosella laticella</i> , new species.....	31
The bilamellar zoarium composed of very wide zooecia with several rounded areolar pores on each side.	
Janjukian, Aire Coastal beds, Victoria.	
FIG. 3. <i>Exochella grandis</i> , new species.....	32
Surface of the unilamellar zoarium with some ovicelled zooecia. One cell has a calcified operculum.	
Balcombian beds at Muddy Creek, Victoria.	
FIG. 4. <i>Schizoporella tenuilamellosa</i> , new species.....	29
Surface of the very thin bilamellar zoarium with a small orbicular and a transverse avicularium before each aperture.	
Balcombian beds at Muddy Creek, Victoria.	
FIG. 5. <i>Schizoporella macgillivrayi</i> , new species.....	29
Fragment of a hollow cylindrical zoarium exhibiting the disarranged zooecia.	
Balcombian beds at Muddy Creek, Victoria.	
FIG. 6. <i>Escharoides erecta</i> , new species.....	33
The free erect, cylindrical zoarium composed of large elongated zooecia.	
Janjukian beds, Gellibrand, Victoria.	
FIGS. 7, 8. <i>Didymosella clypeata</i> , new species.....	32
7. Cellular side of the free, unilamellar zoarium. The frontal shield, with its two foramina, is large and smooth.	
8. Dorsal side of the same specimen.	
Balcombian beds at Muddy Creek, Victoria.	

	PAGE
FIG. 9. <i>Schizoporella arcana</i> , new species.....	30
The unilamellar zoarium showing the large perforation in front of the aperture.	
Balcombian beds at Muddy Creek, Victoria.	
FIG. 10. <i>Microporella cailleti</i> , new species.....	33
The incrusting zoarium with several ovicelled zooecia.	
Balcombian beds at Muddy Creek, Victoria.	
FIG. 11. <i>Fenestulina practexta</i> , new species.....	34
Surface of the bilamellar zoarium showing ascopore much removed from the aperture.	
Janjukian beds at Flinders, Victoria.	

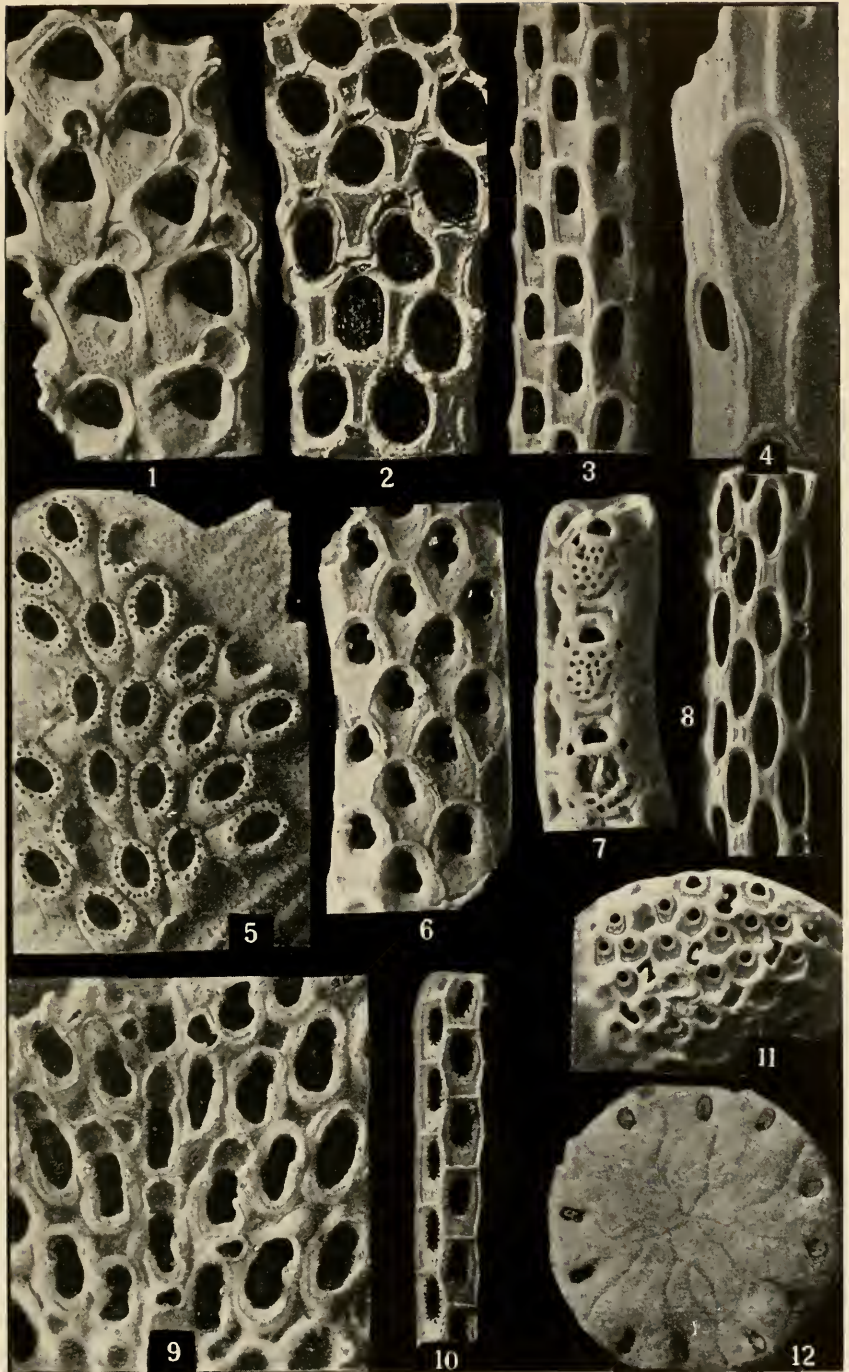

TERTIARY CHEILOSTOME BRYOZOA FROM VICTORIA, AUSTRALIA
(For explanation, see page 45.)

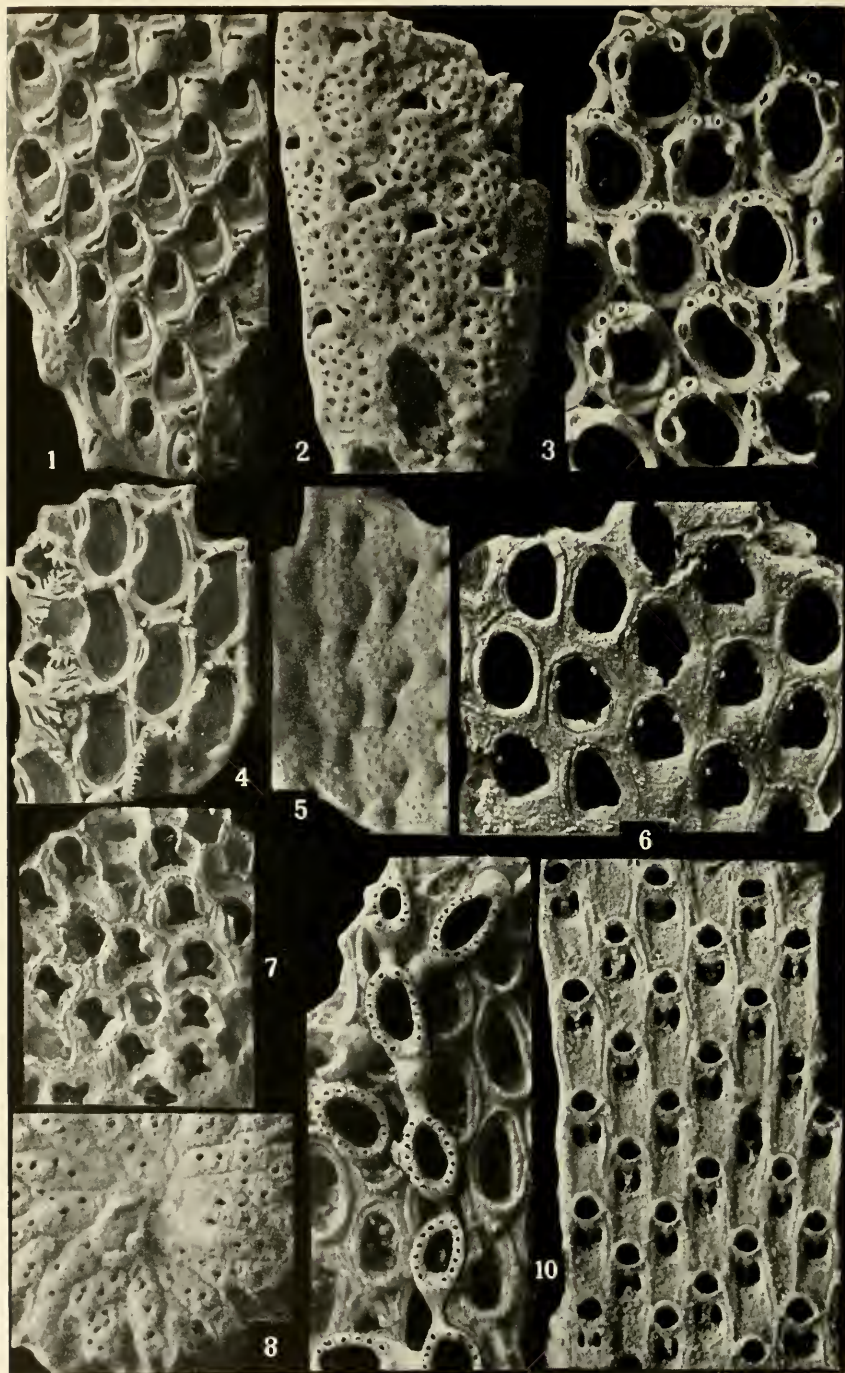

TERTIARY CHEILOSTOME BRYOZOA FROM VICTORIA, AUSTRALIA
(For explanation, see page 46.)

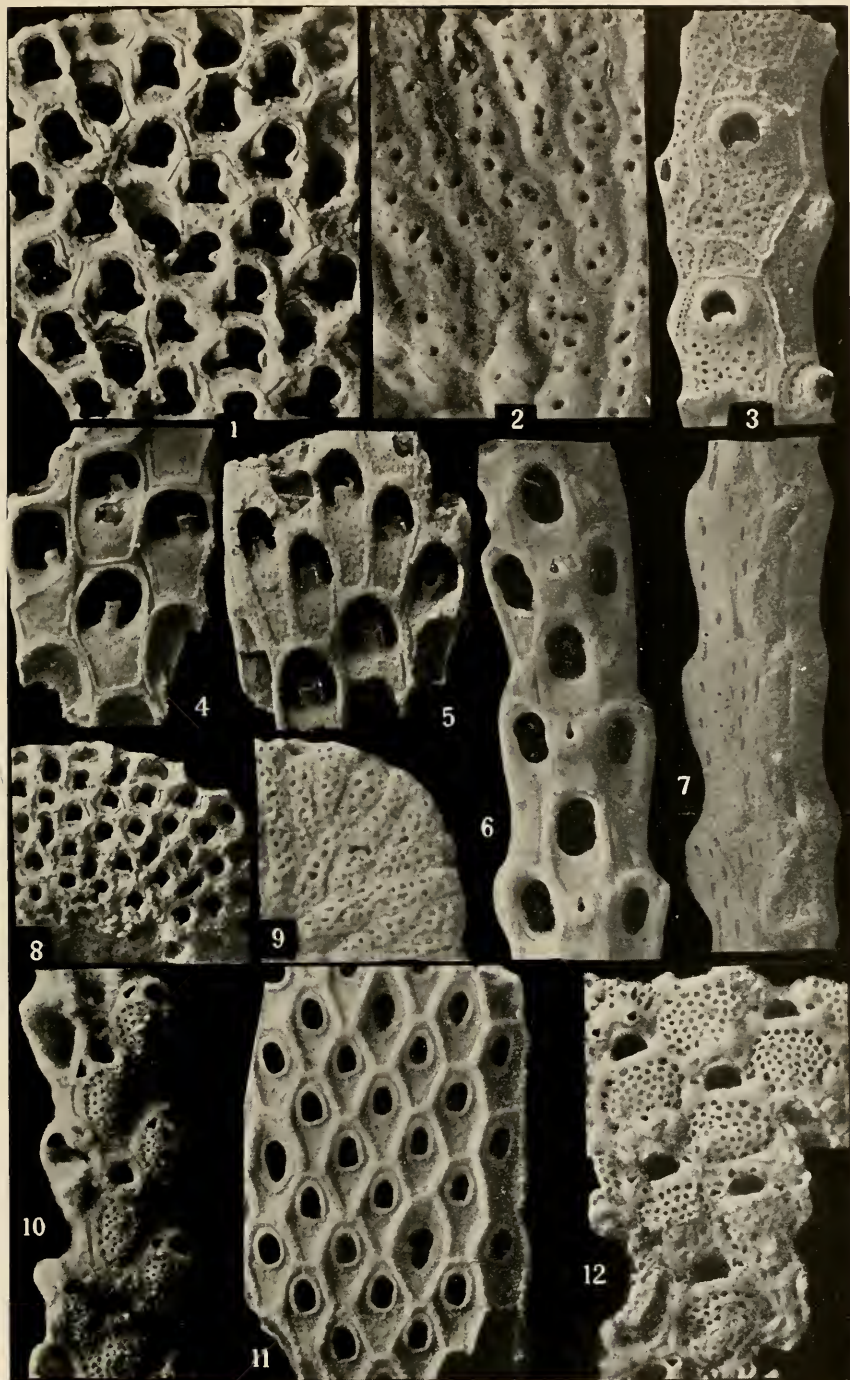

TERTIARY CHEILOSTOME BRYOZOA FROM VICTORIA, AUSTRALIA

(For explanation, see page 47.)

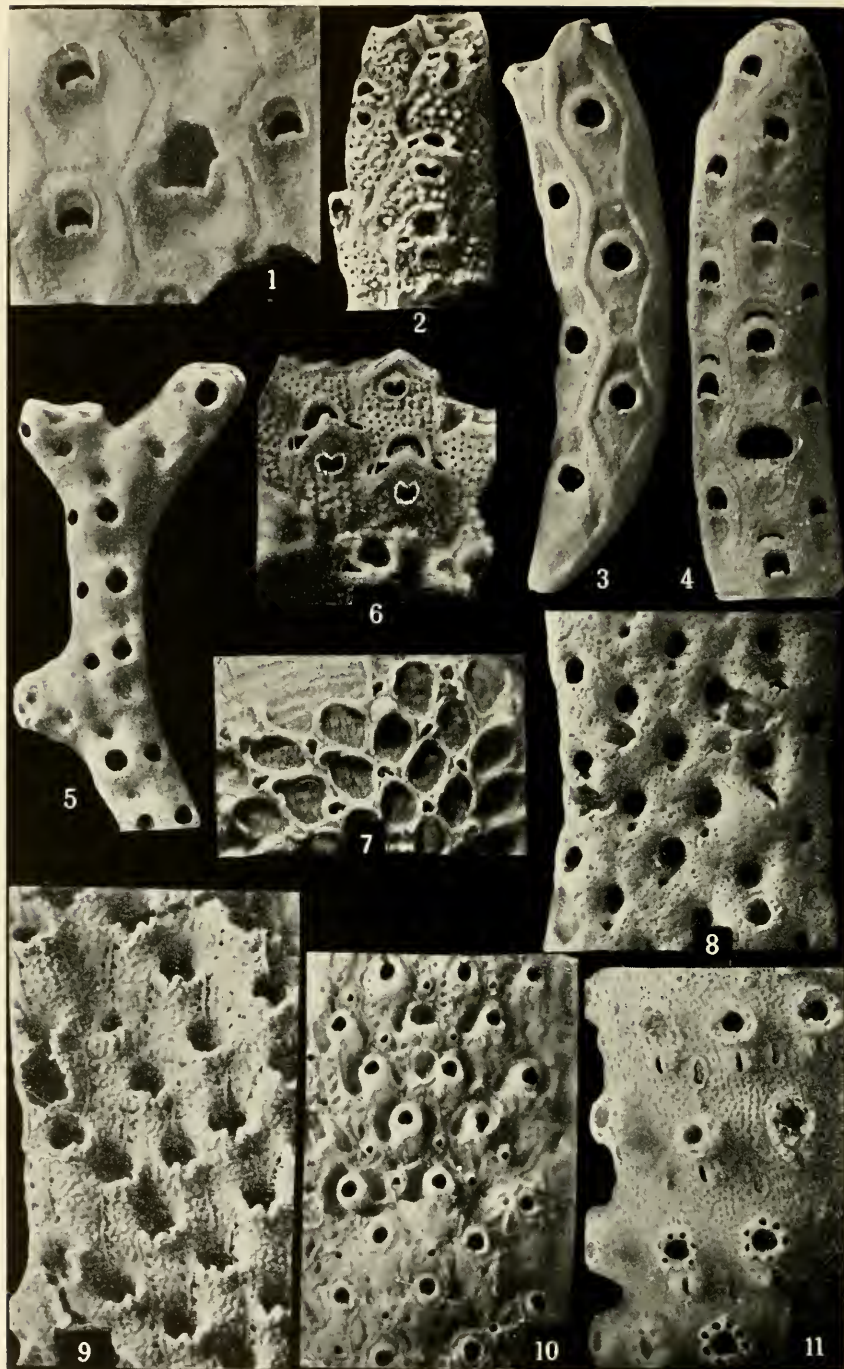

TERTIARY CHEILOSTOME BRYOZOA FROM VICTORIA, AUSTRALIA

(For explanation, see page 48.)

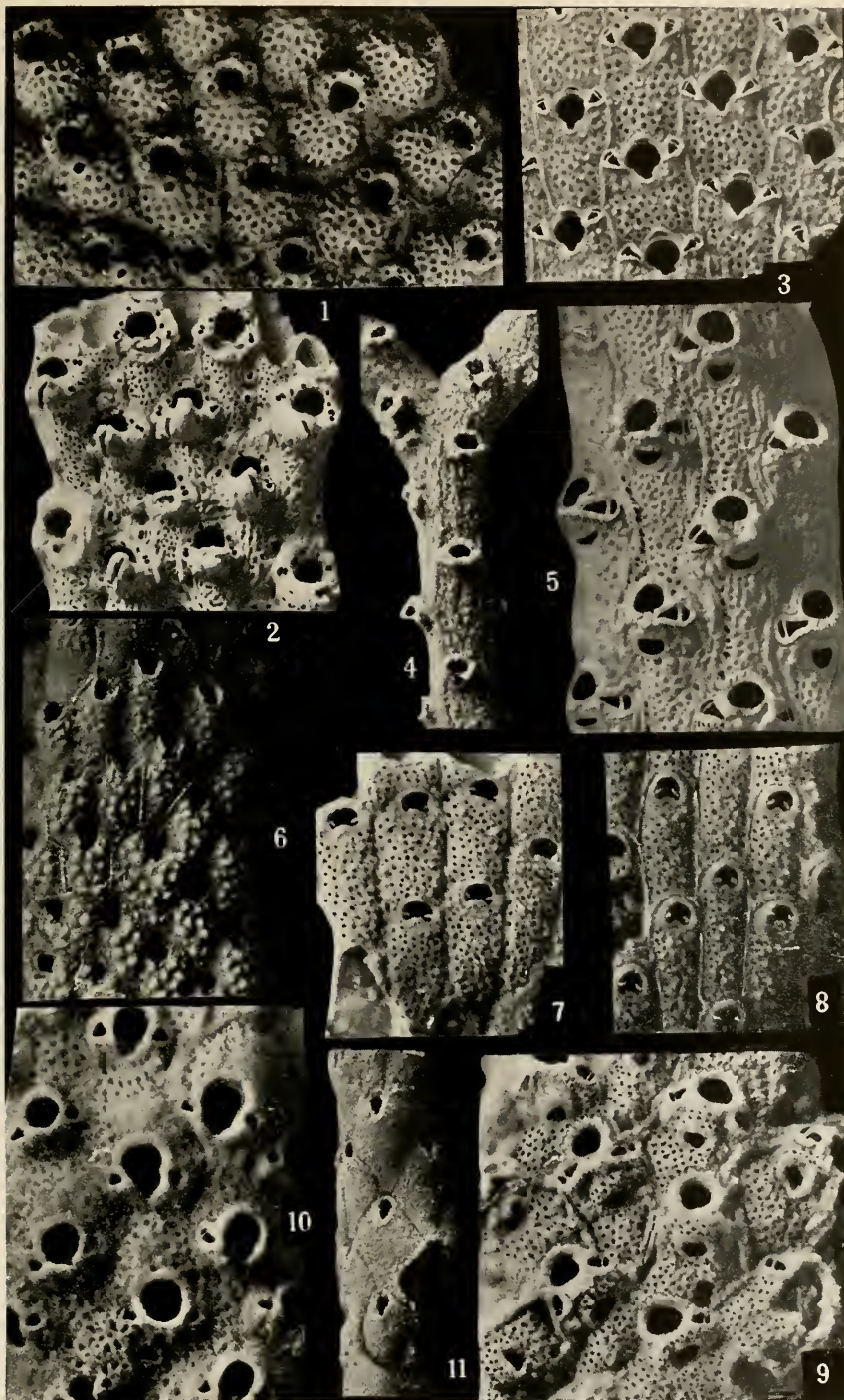

TERTIARY CHEILOSTOME BRYOZOA FROM VICTORIA, AUSTRALIA

(For explanation, see page 49.)

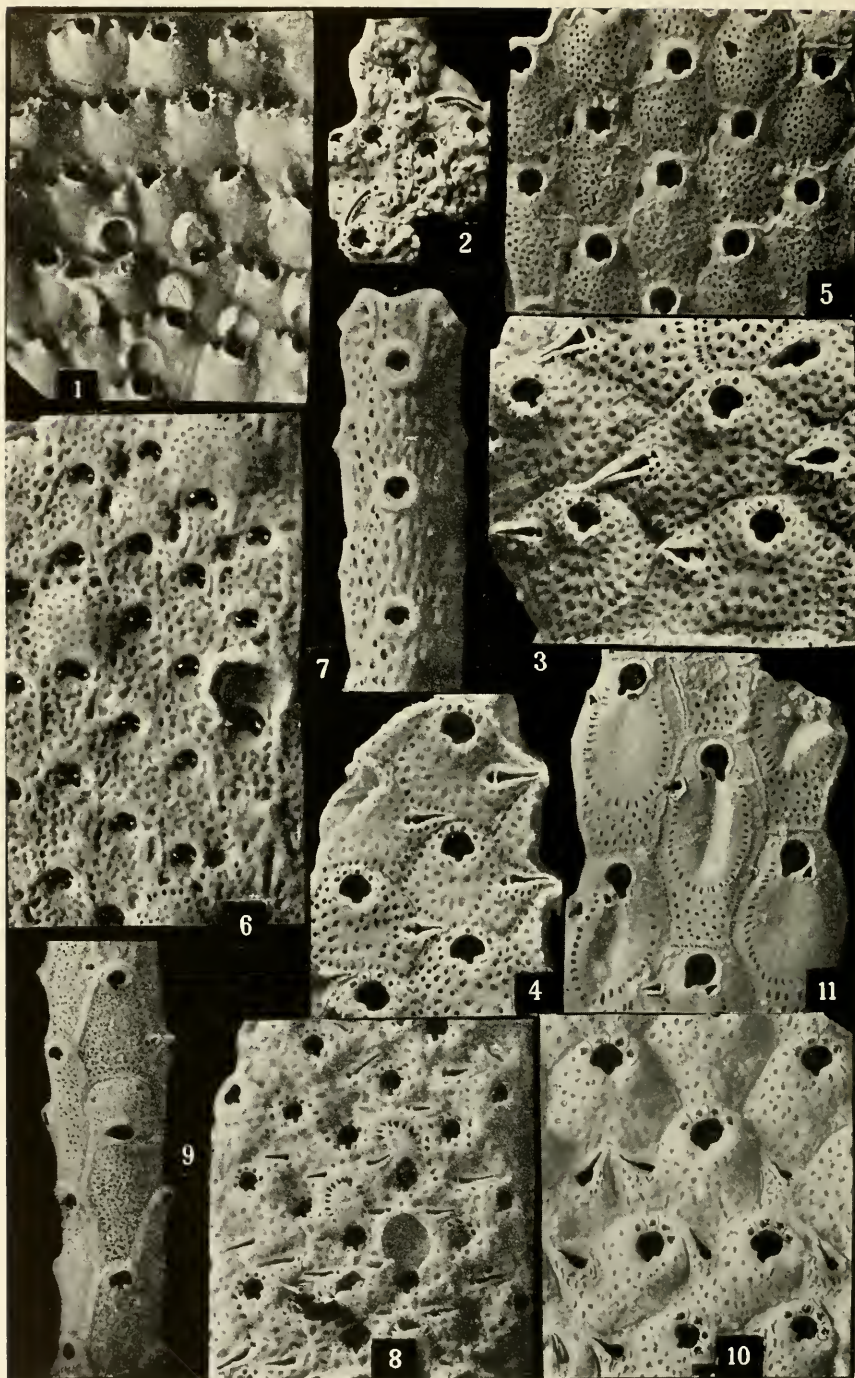

TERTIARY CHEILOSTOME BRYOZOA FROM VICTORIA, AUSTRALIA

(For explanation, see page 50.)

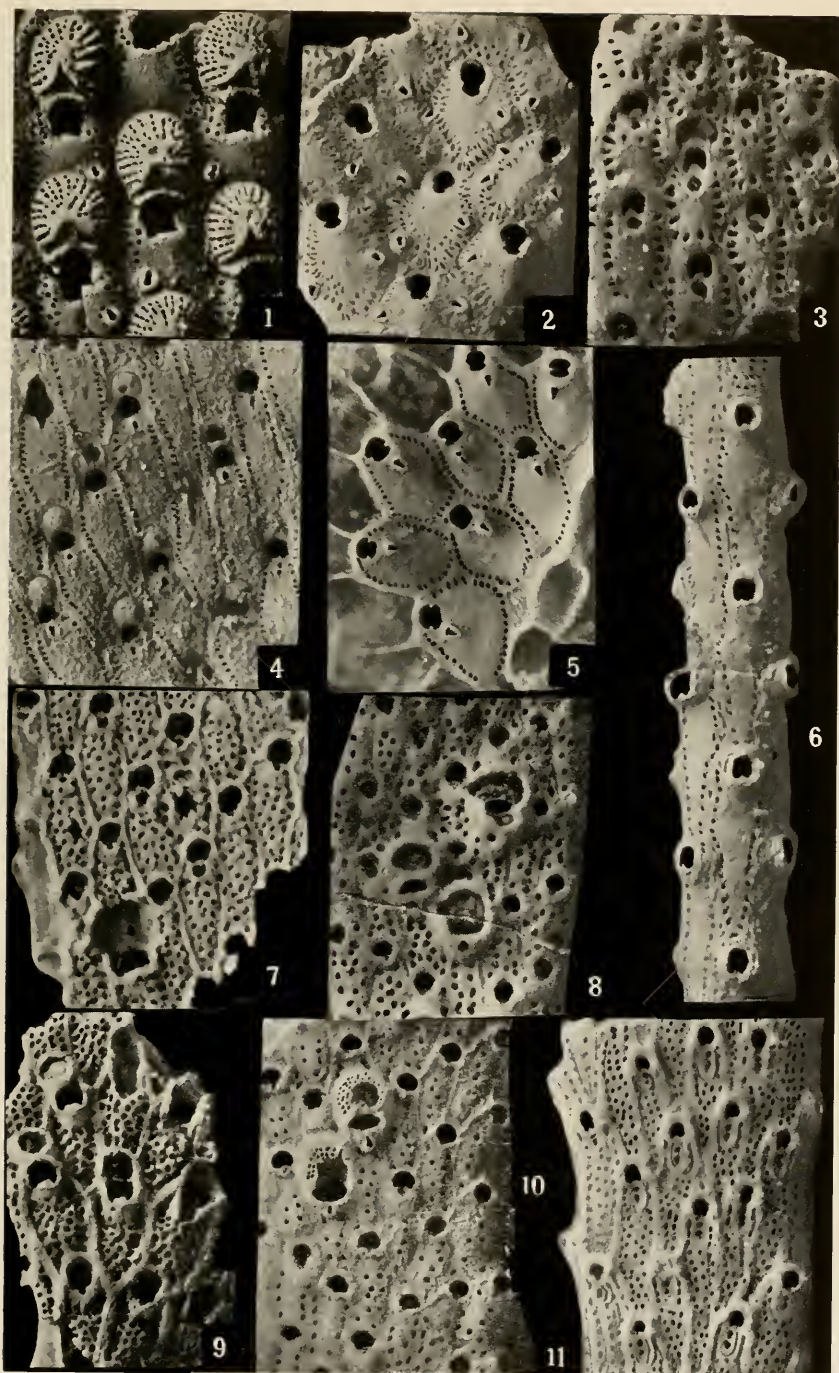

TERTIARY CHEILOSTOME BRYOZOA FROM VICTORIA, AUSTRALIA

(For explanation, see page 51.)

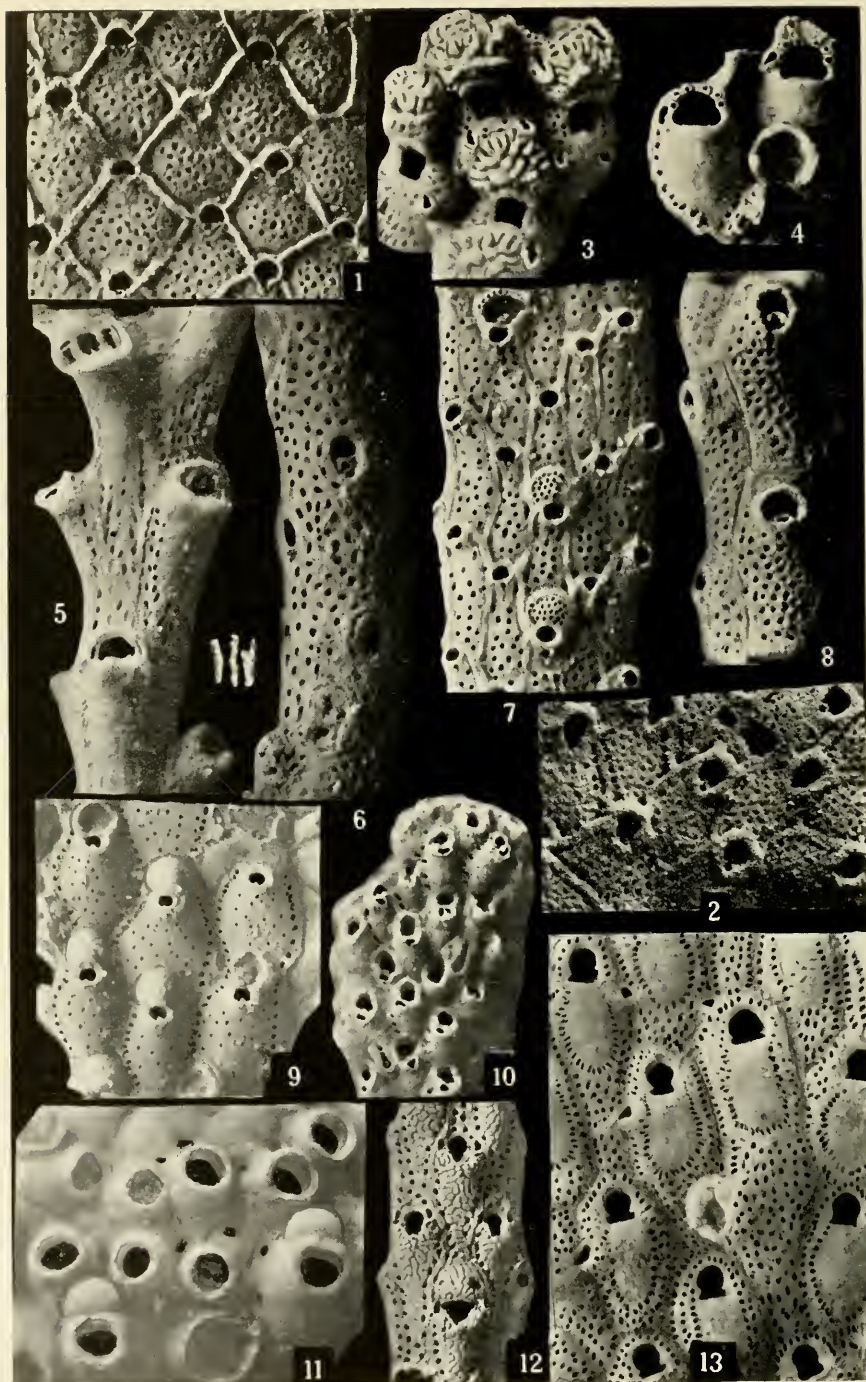

TERTIARY CHEILOSTOME BRYOZOA FROM VICTORIA, AUSTRALIA

(For explanation, see page 52.)

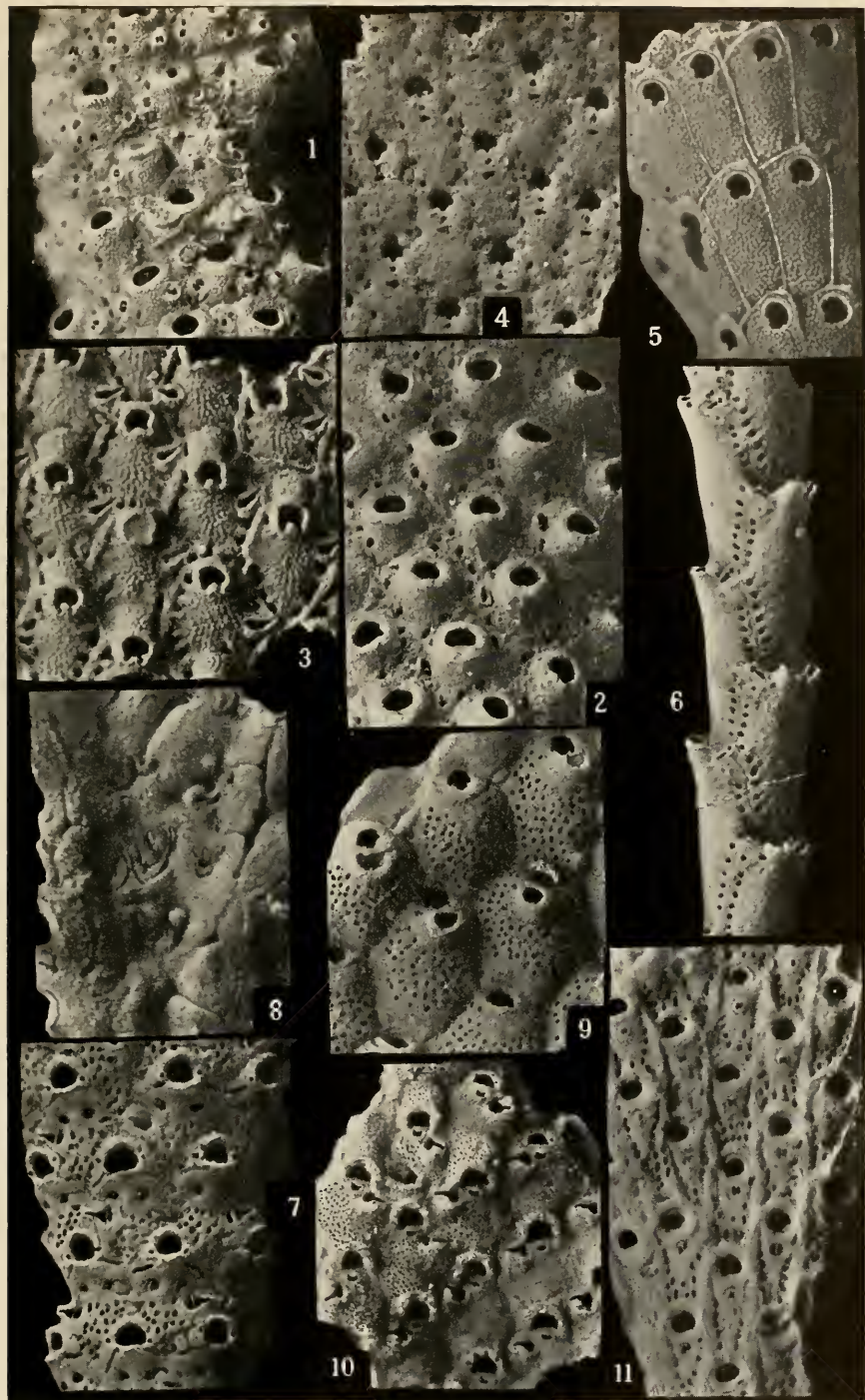

TERTIARY CHEILOSTOME BRYOZOA FROM VICTORIA, AUSTRALIA

(For explanation, see page 53.)

SMITHSONIAN MISCELLANEOUS COLLECTIONS

VOLUME 93, NUMBER 10

(End of Volume)

AN INTRODUCTION TO NEBRASKA
ARCHEOLOGY

(WITH 25 PLATES)

BY

WILLIAM DUNCAN STRONG

Anthropologist, Bureau of American Ethnology



(PUBLICATION 3303)

CITY OF WASHINGTON

PUBLISHED BY THE SMITHSONIAN INSTITUTION

JULY 20, 1935

The Lord Baltimore Press
BALTIMORE, MD., U. S. A.

CONTENTS

	PAGE
Foreword	I
Introduction	6
Historic and traditional background.....	8
Table 1, a digest of certain maps showing the Indian tribes in the region of Nebraska from 1673 to 1819.....	14
The environmental setting.....	30
Previous archeological work in Nebraska.....	40
Historic and protohistoric Pawnee culture as revealed by archeology.....	55
Prehistoric sites recently excavated in Nebraska.....	68
Village on Lost Creek (Dooley site), Franklin County.....	69
Methods of earth-lodge excavation.....	73
House 1	74
Storage or cache pits.....	78
Refuse heaps	81
Pottery	82
Work in ground stone.....	85
Work in chipped stone.....	87
Table 2, classification chart for chipped points.....	89
Table 3, distribution of chipped points according to type..	90
Work in bone.....	94
Bone or antler bracelet fragments.....	97
Work in antler.....	97
Work in shell.....	100
Animal and molluscan remains.....	100
House 2	101
Disposal of the dead.....	103
Ossuary on Prairie Dog Creek (Graham site), Harlan County.....	103
Pottery from Graham ossuary.....	108
Work in ground stone	109
Work in chipped stone	109
Work in bone	110
Work in antler	111
Work in shell	111
Work in copper	114
Negative excavations in vicinity of Graham ossuary.....	114
Conclusions regarding Prairie Dog Creek sites.....	116
Ossuary on the Republican River (Marshall site), Harlan County....	116
Artifacts from Marshall ossuary.....	120
Conclusions regarding Marshall ossuary.....	121
Ossuary on Republican River near Alma, Harlan County.....	122
Ossuary on Munson Creek, Howard County.....	123

	PAGE
Village near Rock Bluffs (Rock Bluffs site), Cass County.....	124
House 1	126
House 2	126
Storage pits	129
Refuse heaps	130
Pottery from House 2.....	130
Work in ground stone.....	133
Work in chipped stone.....	134
Work in bone.....	136
Work in shell.....	136
Basketry	137
Animal and molluscan remains.....	137
House 3	138
Disposal of the dead.....	139
House site near Rock Bluffs (house 5).....	139
Pottery	139
Work in ground stone	140
Work in chipped stone	142
Work in bone	142
Vegetal remains	143
Village between the Platte River and Papillion Creek (Gates site), Sarpy County	143
House 1	147
Pottery	151
Work in ground stone	152
Work in chipped stone	153
Work in bone and miscellaneous material.....	153
House 2	154
Storage or cache pits.....	157
Pottery	158
Work in ground stone	161
Work in chipped stone	162
Work in bone	163
Work in antler.....	164
House 3	164
Pottery	165
Other artifacts	166
House 4	166
Organic remains	167
Village and ossuaries near the mouth of the Elkhorn River (Saunders site), Douglas County.....	168
" Mound " 1	170
" Mound " 2	171
House 1	172
The Walker Gilmore (stratified) site, Cass County.....	175
Nebraska culture (surface deposits).....	180
Disposal of the dead (Nebraska culture?).....	182
The Sterns Creek culture (deep strata).....	184
Habitations	184
Pottery	187

	PAGE
Work in ground stone	190
Work in chipped stone	190
Work in bone	191
Work in antler	192
Work in shell	193
Work in wood	193
Vegetal remains	193
Animal and molluscan remains.....	194
Probable antiquity of the Sterns Creek culture.....	195
Suggestions for further work.....	196
Burial mounds and native quarries in the Weeping Water Valley, Cass County	198
The problem of Nebraska mounds.....	205
Surface sites on the Dismal River, Hooker County.....	212
Gravel deposit containing artifacts and fossilized bones (Bird Creek canyon site), Sarpy County.....	217
Recent discoveries of human artifacts associated with extinct mammals in Nebraska and closely adjacent regions.....	220
Signal Butte, a stratified site in Scotts Bluff County.....	224
Geologic background	225
Method of excavation.....	227
Cultural evidence by levels.....	228
Ceramics	229
Ground stone	230
Chipped stone	230
Bone and antler work.....	234
Shell work	235
Animal remains	235
Considerations of relative age.....	236
Other sites and regions in Nebraska.....	239
Grouping of sites and summary of cultures represented.....	245
The Upper Republican culture.....	245
Table 4, grouping of Nebraska archeological sites according to cultures	246
Table 5, types of rims from two Upper Republican culture sites...	248
The Nebraska culture.....	250
Table 6, types of rims from Nebraska culture sites excavated by the Survey	253
The Sterns Creek culture.....	267
Signal Butte cultures (II and I).....	269
Other sites	270
Culture sequence and development in Nebraska.....	271
Table 7, sequence of cultures in Nebraska (and northern Colorado) .	272
Cultural affiliations with adjacent areas.....	282
Conclusion	294
Literature cited	300
Explanation of plates.....	310
Index	317

ILLUSTRATIONS

PLATES

	PAGE
1. Historic Pawnee pottery and typical artifacts, Hill site (<i>circa</i> 1805)...	316
2. Protohistoric Pawnee rim sherds, Schuyler and Burkett sites (<i>circa</i> 1600)	“
3. Restored protohistoric Pawnee pots, Burkett site (<i>circa</i> 1600).....	“
4. Lost Creek site, Upper Republican culture.....	“
5. Rim sherds from Lost Creek, house 1 and vicinity, Upper Republican culture	“
6. Bone and antler artifacts of the Upper Republican culture, and bison scapulae digging tools from various Nebraska cultures.....	“
7. Types of chipped points, end scrapers and knives from various Nebraska cultures	“
8. Prairie Dog Creek ossuary, Upper Republican culture.....	“
9. Rim sherds from Prairie Dog Creek ossuary, and bone, shell and copper artifacts, Upper Republican culture (toggled harpoon, Nebraska culture)	“
10. Marshall and Prairie Dog Creek ossuaries.....	“
11. Shell artifacts from Upper Republican and Nebraska cultures, and types of beads from various sites in Nebraska.....	“
12. Nebraska culture sites.....	“
13. Large pot, house 2, Rock Bluffs, Nebraska culture.....	“
14. Nebraska culture pottery.....	“
15. Nebraska culture rim sherds.....	“
16. Nebraska culture modeled face-pipe, lugs, basketry impression; and types of tobacco pipes from various Nebraska cultures.....	“
17. Ground and large chipped stone artifacts, various Nebraska cultures...	“
18. Bone and antler artifacts, mainly Nebraska culture; and Sterns Creek culture artifacts	“
19. Sterns Creek culture, Walker Gilmore site.....	“
20. Mound and quarry trench, Cass County.....	“
21. Upper Republican culture artifacts from various sites.....	“
22. Potsherds from Dismal River sites, Hooker County; and artifacts with fossilized bison bone, Bird Creek canyon, Sarpy County.....	“
23. Stratified site on the summit of Signal Butte, Scotts Bluff County.....	“
24. Artifacts from the two upper occupation levels (II and III), Signal Butte	“
25. Artifacts from the lowest occupation level (I), Signal Butte.....	“

TEXT FIGURES

1. Map showing general location of recently investigated archeological sites in Nebraska.....	8
2. Map of tribes in Nebraska (<i>circa</i> 1800) in relation to geographic areas.	9
3. Floor plan of protohistoric Pawnee earth lodge, Burkett site, Nance County	64

	PAGE
4. Sketch map of Lost Creek district, Franklin County.....	70
5. Floor plan, house 1, Lost Creek.....	72
6. Cross-section of house 1, Lost Creek.....	75
7. Form classification for chipped points.....	88
8. Sketch map of Prairie Dog Creek district, Harlan County.....	104
9. Ground plan of Graham site.....	105
10. Cross-section of Graham site.....	106
11. Ground plan of Marshall site.....	118
12. Cross-section of Marshall site.....	119
13. Sketch map of Rock Bluffs district, Cass County.....	125
14. Ground plan and cross-section of house 2, Rock Bluffs.....	127
15. Sketch map of Gates site village, Sarpy County.....	145
16. Ground plan of house 1, Gates site.....	148
17. Cross-section, west to east, house 1, Gates site.....	149
18. Cross-section, south to north, house 1, Gates site.....	149
19. Ground plan, houses 2 and 3, Gates site.....	155
20. Cross-section, north to south, house 2, Gates site.....	156
21. Cross-section, west to east, house 2, Gates site.....	158
22. Cross-section, north to south, house 3, Gates site.....	165
23. Sketch map of Platte River, above and below junction of Elkhorn River.	169
24. Sketch map of Walker Gilmore site, Cass County.....	176
25. Ash strata and hearths at exposure 4, Sterns Creek culture, Walker Gilmore site	185
26. Ash strata, hearth, and post molds at exposure 10, Sterns Creek culture, Walker Gilmore site.....	186
27. Sketch map of aboriginal sites on Weeping Water Creek, Cass County.	199
28. Cross-section, mound 2, Weeping Water Creek.....	200
29. North to south cross-section through central portion of earth cap on top of Signal Butte.....	226
30. Effigy heads from Nebraska culture sites.....	258

AN INTRODUCTION TO NEBRASKA ARCHEOLOGY

BY WILLIAM DUNCAN STRONG

Anthropologist, Bureau of American Ethnology

(WITH 25 PLATES)

FOREWORD

The present paper was completed in April 1932, but publication at that time was not possible. It was revised and brought up to date during the early part of 1935. Since at that time the bulk of the manuscript was already written, it proved impractical to incorporate throughout the new terminology and taxonomic method proposed by McKern (1934) and others for Middle Western archeology. However, every effort has been made herein to present all the cultural data (wherever possible in statistical form) from each individual site, and it is hoped that the materials thus afforded may be fitted into whatever system of cultural classification may be desired.

Wedel (1935, IV) has prepared a "Preliminary Classification for Nebraska and Kansas Cultures" along the lines suggested by McKern. There follows a very similar classification for the cultural groupings discussed in the present paper. This should be considered in relationship to the later section, "Grouping of Sites and Summary of Cultures Represented". If it is remembered that in the present report the much abused term "Culture" has been primarily employed to designate what is implied by the newly proposed, and useful term, "Aspect", a major difference between the two terminologies will disappear. The "Central Plains Phase" is tentatively introduced to distinguish certain groupings of sites which, although similar in many ways, differ in house types, ceramics, and certain other features from Upper Mississippi Aspects. The "Woodland Phase" is not given Basic Culture status because of its definite Mississippi Basic Culture affiliations (see Setzler, 1933). A "Great Plains Basic Culture" and an "Early Hunting Phase" are introduced to include those Plains sites which show no Basic Mississippi or other already classified influences. The present groupings are purely tentative, and certain of them will undoubtedly be revised in the light of fuller data.

Suggested Cultural Classification for Certain Nebraska (and Colorado) Sites

Basic culture	Phase	Aspect	Focus	Component
Mississippi	Upper Mississippi	Nebraska	Omaha	Rock Bluffs, Gates Saunders, Walker Gilmore II.
			St. Helena	Butte, St. Helena, etc.
	Central Plains	Upper Republican	Lost Creek	Lost Creek, Prairie Dog Creek, etc.
			Sweetwater	Sweetwater, Munson Creek, etc.
			Medicine Creek North Platte	Medicine Creek Signal Butte, III, etc.
	Woodland	Lower Loup (Protohist. Pawnee?)	Beaver Creek	Burkett, Schuyler, etc.
Lower Platte (Historic Pawnee)			Columbus	Horse Creek, Fullerton, Linwood, etc.
			Republican	Hill, etc.
Great Plains	Early Hunting	Iowa "Algon- kian"	Sterns Creek	Walker Gilmore I
			Signal Butte II(?)	Signal Butte II
		Signal Butte I	Signal Butte	Signal Butte I
		Folsom	Northern Colorado	Lindenmeier (Colo.)

The bulk of the new material included in the present paper was obtained while the writer was professor of anthropology at the University of Nebraska from 1929 to 1931. In 1929 an archeological survey of the State was established by the University of Nebraska, and the greater part of the field work here reported on was accomplished under these auspices. The writer takes this opportunity to thank the Regents of the University of Nebraska and to acknowledge his great debt to Chancellor E. A. Burnett, Deans J. D. Hicks (now of the University of Wisconsin) and F. W. Upson, and Profs. E. H. Barbour and J. O. Hertzler, who made the work possible. He is also obligated to the Smithsonian Institution for an additional grant for field work in 1930 and 1931 under the provisions of the "Fund for Cooperative Ethnological and Archeological Investigations". In July 1931 the author assumed a position as anthropologist with the Bureau of American Ethnology, Smithsonian Institution. The present report

has been organized and written since his connection with the latter institution and also includes certain data obtained in the field during the summers of 1931 and 1932 under the same auspices. During the latter summer, the Laboratory of Anthropology at Santa Fe cooperated with the Bureau of American Ethnology in excavation work at Signal Butte and in South Dakota. A condensed account of the major results at Signal Butte appears in the present paper.

At the University of Nebraska much valuable assistance has been received from Drs. A. L. Lugin, Nels A. Bengtson, W. Van Royen, Glenn W. Gray, Robert L. Reynolds, the latter now connected with the University of Wisconsin, and Earl H. Bell, the present Director of the University of Nebraska Archeological Survey. Among the large number of students who assisted, both in the field and in the laboratory, Michael O'Heeron, Frank Morrison, Bertrand Schultz, Loren Eiseley, Lee Daniels, Newell Joyner, and Paul McGrew were especially helpful. Maurice E. Kirby, who served as engineer, draftsman, and geologist on the 1932 expedition, rendered invaluable services both in the field and after our return. In Waldo Wedel the writer had a field assistant who possessed an excellent archeological technique, a clear grasp of essential problems, and a stimulating enthusiasm for the work at hand. To Wedel was assigned the important task of dealing with historic Pawnee archeology in Nebraska, which study, with the indispensable aid of A. T. Hill, of Hastings, he has successfully inaugurated.

For criticism and advice on various ethnological and historical aspects of the present problem the author is grateful to Dr. John R. Swanton, of the Bureau of American Ethnology, and to Dr. Robert H. Lowie, professor of anthropology at the University of California. Frank H. Setzler, of the United States National Museum, and Dr. Frank H. H. Roberts, Jr., of the Bureau of American Ethnology, have also furnished valuable assistance and criticism. To Dr. A. Wetmore, Gerrit S. Miller, Jr., and Dr. C. L. Gazin, of the United States National Museum, I am obligated for reports on the avian and mammalian faunal remains from Signal Butte. Through the kind permission of Dr. Frederick H. Sterns it has been possible to incorporate herein certain facts and summaries contained in his extremely valuable unpublished paper on the "Archeology of Eastern Nebraska", now on file at the Harvard University Library. To Dr. Sterns, and to the members of the anthropology department of Harvard University, the author is very grateful for the opportunity thus afforded. Further technical assistance was furnished by Dr. Melvin H. Gilmore, of the University of Michigan, and Dr. Frank C. Baker,

of the University of Illinois, who respectively identified certain botanical and molluscan remains recovered in our excavations. Without their aid many significant determinations would have been impossible. To Dr. Paul B. Sears, of the University of Oklahoma, both Maurice E. Kirby and the writer are very grateful for analyses and suggestions concerning the soil conditions on Signal Butte.

In the location of sites, in preliminary survey work, in regional comparisons of artifact types, and often in actual excavation, the efforts of the Nebraska Archeological Survey were supplemented by the assistance of several Nebraska archeologists and a number of other interested persons. Without this cooperation much of the data here presented would never have been assembled. Two archeologists of long standing, Dr. Robert F. Gilder and E. E. Blackman, were especially kind in furnishing a newcomer orientation in a field with which they were so familiar and in furnishing valuable information. To A. T. Hill, Director of the State Historical Society Museum, and to Dr. G. H. Gilmore, of Murray, the writer is particularly indebted. The exact nature of this debt will become evident in the following pages. In addition, John Champe, of Lincoln, Thomas L. Green, of Scottsbluff, Gene P. Spence, of Franklin, Karl L. Spence, of Crawford, A. L. Bishop, of Omaha, L. E. Simmerman, of Fremont, J. B. O'Sullivan, of O'Neill, and Ralph Douglas, of Bloomington, all assisted the Survey in a number of ways. The information thus gained and the pleasure afforded by such associations are appreciated beyond any brief acknowledgment that the present writer might make.

It must be obvious that the present paper is actually a cooperative piece of work wherein the writer has been directly and materially aided by a large number of persons. Of this latter group only a small proportion have been professional archeologists, the majority being persons in other walks of life who have been drawn to archeology as an avocation. Owing to the increasing interest in prehistoric research in this country, the number of amateur archeologists is growing rapidly. Encouraging as this rising interest in archeology undoubtedly is, it must frankly be admitted that inasmuch as it is often unaccompanied by technical knowledge, it is both a potential and an actual danger. This is demonstrated by the rapidly increasing destruction of important archeological sites, either by enthusiastic but untrained amateurs or by persons who are frankly mere collectors or relic hunters. There is a world of difference between these two types. The former is interested primarily in the human story suggested by the arrowpoints or potsherds he finds and carefully preserves; the latter regards such specimens as mere curios or relics, to be

dug up, hoarded for a while, then, unless they can be sold to other collectors for a paltry sum, to be lost and forgotten. Persons of the first type may be scientific archeologists in the making; those of the second type uselessly destroy the very stuff of human history.

Like all professions, sciences, and arts, archeology must be learned, for it involves methods and techniques which, though often basically simple, are fundamental. Furthermore, it deals with extremely limited and perishable aspects of human history, and such evidence if once destroyed is irreplaceable. The specimen wrenched from its context means little or nothing. The story that is hidden in the ground is the significant thing, and this is totally destroyed by careless or unskilled excavation. Therefore the beginner in archeology who is truly interested in the subject will do no digging. This need not stop his field activity, however, for in nearly all regions there are numerous specimens to be found on the surface of the ground, in plowed fields, and in cut banks. A collection of such artifacts carefully labeled as to the exact place of finding has great scientific value. When systematic archeology begins in any region, such collections furnish the first leads toward tracing out the prehistory of the area.

If the worker's interest grows stronger he should get in close touch with the centers of archeological research in his State,¹ and having fully equipped himself for the task, will be in a position to contribute a larger share toward the elucidation of the prehistoric problems of the region.

INTRODUCTION

Despite the fact that geological, geographical, and faunistic considerations all suggest the Great Plains as a highly probable home for early man in North America, while the great river valleys of the plains have from time immemorial offered migration routes and ideal habitation sites for both hunting and horticultural peoples, an idea seems to have been prevalent that the region had no archeology worthy of the name. It is the purpose of the present paper to present the results so far attained through historic and prehistoric archeological research in certain portions of only one of the central States of this great natural area. Although modern political boundaries obviously need have no ethnic significance, they serve as convenient and

¹ Usually the State University, historical society, or museum is more or less active in such research. Contacts with active and trained workers in any part of the United States may also be made by writing the Committee on State Archaeological Surveys (of the) National Research Council, Washington, D. C., or the Bureau of American Ethnology, Smithsonian Institution, Washington, D. C.

practical divisions in attacking a problem as vast as this one promises to be. Far from apologizing for such an arbitrary limitation, the writer hastens to emphasize the fact that as far as Nebraska itself is concerned the present work has been a mere sampling of a very promising field. It is at best an introduction to a series of important problems and in no sense purports to be a final report.

That the more recent work may assume significance in relation to that which had already been accomplished, a fairly exhaustive résumé of previous archeological work in Nebraska has been included. Moreover, since comparative recency of white occupation in the region permits the determination of many historic aboriginal sites with unusual exactitude, considerable emphasis has been put upon this line of approach to the past through the historic present. In all cases the conscious effort has been to approach the unknown through the known, the prehistoric through the historic. In actuality there have been deviations from this ideal, but where followed out this top-to-bottom method has yielded the best results. Few regions seem to promise more fruitful returns to a closely combined historical, ethnological, and archeological approach than do the Great Plains, and Nebraska has not proved a disappointment in this regard. In addition, since the interior plains of North America offer a special environmental setting for human development, the physical geography of Nebraska has been outlined in an effort to determine whether any correlation exists between cultural types and topographic, climatic, and biotic subareas. The direct purpose of all these lines of approach is to obtain a cross-section of human history in the central part of the Great Plains.

To the writer, ethnology and archeology, far from being isolated studies, are actually two inseparable means to an essential end—the attainment of the most complete understanding possible of human culture at all places and in all times. The more complete data of ethnology permit certain deductions concerning the past, but these can be objectively checked only when the archeological record is also known. To ignore those important aspects of any human society that can be understood solely by reference to the historic and prehistoric past, is as inadmissible scientifically as it is fraught with danger from the practical standpoint. In two earlier studies (1927 and 1929) I made an attempt to present and analyze the available data on social and ceremonial life among the native peoples of the Southwest. From these ethnological data certain conclusions regarding the history and development of social institutions in the area seemed evident. Checked against the very full and objective record

of Southwestern archeology, the ethnological inductions, which were independently arrived at, agreed in all basic essentials.

In the present paper the problem is reversed, for the peoples of the Great Plains have received much ethnological study, whereas their archeology has, up to very recent times, received little serious attention. Therefore, an attempt is here made to fill in part of the prehistoric record for a portion of the central Great Plains by objective archeological techniques, such as the correlation of material cultural complexes with (exact) historic tribal locations, stratification of habitation levels, and the occurrence of human artifacts in deposits of determinable geological sequence. The results of this inquiry have in turn been used as a check regarding current ethnological theories and sequences postulated for the cultural history of the central plains. In the present case the results of direct archeological research and of current ethnological theory fail to synchronize so closely. This has significant implications regarding the essential value of such a coordinated ethnological and archeological approach, which will be stressed in the conclusion.

HISTORIC AND TRADITIONAL BACKGROUND

The march of Coronado across the buffalo plains to the provinces of Quivira and Harahey in 1541 is the romantic prologue to the short but vivid drama of Indian history in the Great Plains of North America. In the brief descriptions vouchsafed us by the various chroniclers of the expedition, references occur to the "governor of Harahey and Quibira," to the characteristics of the two provinces, and to their numerous sedentary inhabitants. Subsequent researches have strongly indicated that the Quibira or Quivira of Coronado was in northeastern Kansas and that its inhabitants were the Wichita Indians, while Arache, Arahei or Harahey to the north was the country of the Pawnee presumably in Nebraska. These conclusions, based on geographic, linguistic, and ethnographic evidence, regarding the native peoples of Quivira and Harahey indicate that almost 400 years ago the Plains region west of the Missouri River in Kansas and Nebraska was occupied by Caddoan-speaking peoples who lived in numerous permanent villages and cultivated corn, beans, and pumpkins. As the inhabitants of Harahey appear to have been the Pawnee, they are thus the first Nebraska tribe to be recorded in history. The chroniclers clearly distinguish between the purely nomadic buffalo hunters encountered by the expedition farther to the south and the settled inhabitants of Quivira and Harahey; hence when the curtain rises on Kansas and Nebraska it is a horticultural rather than a purely

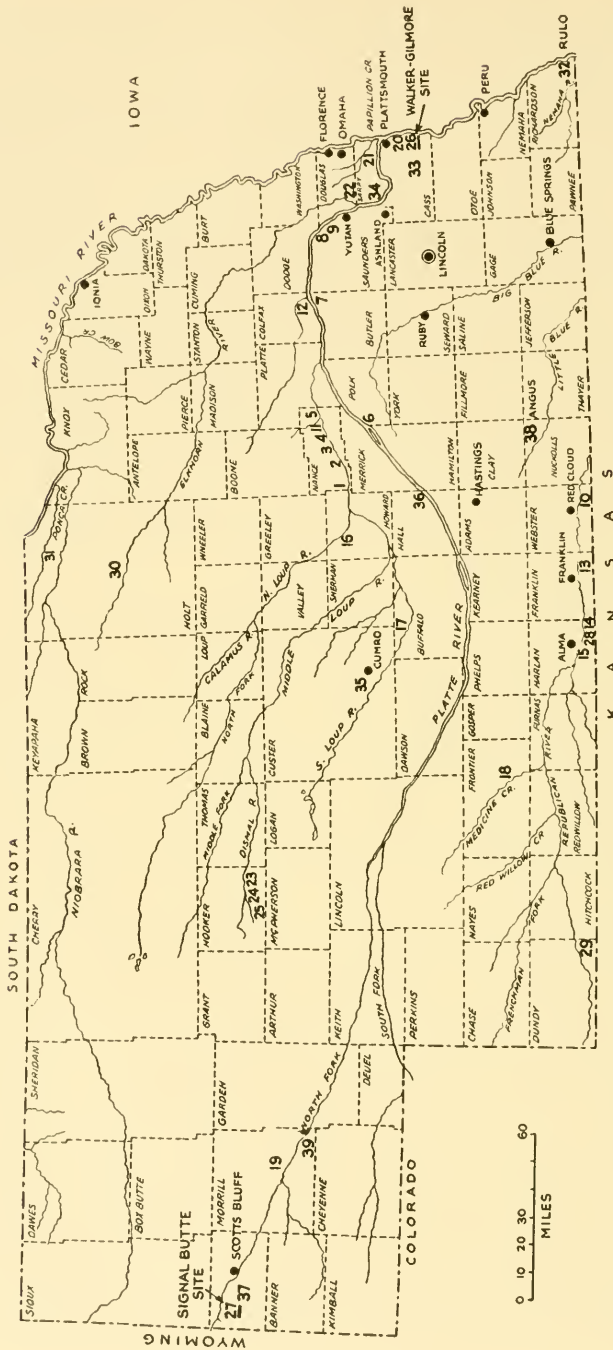

FIG. 1.—Map showing general location of recently investigated archeological sites in Nebraska. Numerals listed and classified in table 4 (p. 246). Underlined sites (numerals) are stratified.

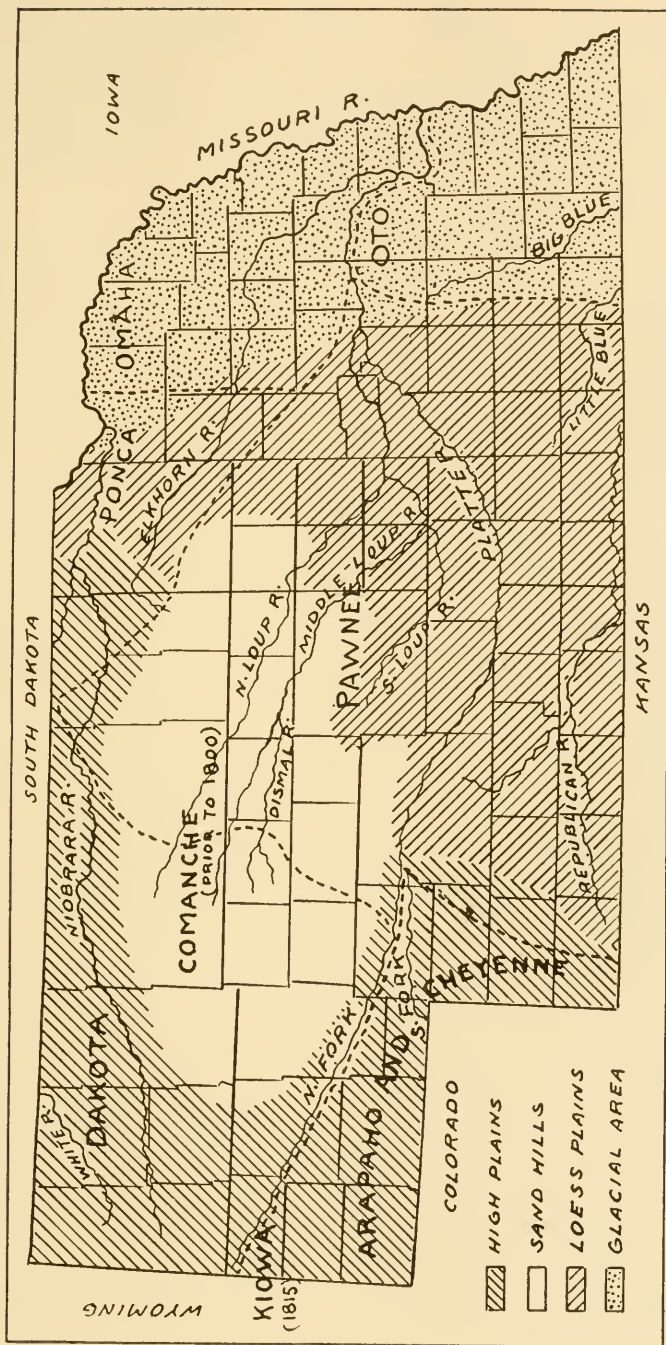

FIG. 2.—Map of tribes in Nebraska (circa 1800) in relation to geographic areas.

hunting scene that is revealed.¹ Subsequent Spanish expeditions in 1593, 1601, 1618, and 1634, concerning which even less is on record, reached as far north and east as the indefinite region that had then come to be designated as Quivira. The Llano Estacado stood as a barrier, the way was long, and observable profit lacking. Hence, even before the Pueblo revolts of 1680 and 1696, Spanish enterprise had been for some time temporarily diverted to the south.

The next act of our drama, therefore, finds adventurous French traders, missionaries, and explorers pressing from the northwest toward the Gulf and later to the north and west in quest of furs, converts, and territory. Long before any written accounts French traders were living with the tribes on the Missouri River, and almost the only record of their discoveries is preserved in various maps drawn up by European cartographers from word-of-mouth accounts. Some first-hand knowledge of the Missouri River tribes from 1719 to 1801 can be gained from the bare records or more rare accounts of such men as Du Tisé, Charlevoix, Bourgmont, the Mallet brothers, the La Vérendryes, father and sons, Truteau, Perrin du Lac, and Le Raye, but on the whole this was a period of silent commercial expansion or exploitation rather than one of scientific or even political exploration.

The European horse had been first introduced into the Plains by the early Spanish explorers and later by trade, or through raids of the southern Indians on Spanish-Mexican rancherías. By 1682 the Pawnee were in possession of horses, and it is possible that the tribes south of the Platte had them as early as 1600.² Hence the native culture of the Plains during this period of the late seventeenth and early eighteenth centuries was being greatly modified. Not only did traveling become easier and more rapid, but buffalo hunting was now possible by new and easier methods. Many tribes were thus

¹ For the accounts of the various chroniclers see Winship, 1896, pp. 528, 577, 590, 591. The *Relacion del Suceso* as translated by Winship, p. 577, regarding Quivira, reads, "they have corn, beans and melons" whereas the Spanish text, T. P. Smith, 1857, p. 152, reads "maiz e frisoles e calabazas", i. e., the fruit of pumpkins or gourds as the last item. For regional and tribal identifications: Bandelier, 1890, pp. 44, 170; 1893, pp. 235, 239; and F. W. Hodge in Brower, 1899, pp. 29-73. The nomads mentioned in the chronicles may have been bands of Apache, Tonkawa, or Comanche, Winship, 1896, p. 396. By implication Wissler, 1920, pp. 148-149, cites the description of these nomadic hunters as though it applied rather universally to the cultural status at the time of such Plains tribes as the Pawnee, though elsewhere, 1914, pp. 14, 25, he is more explicit.

² Wedel, no date. Wissler, 1914, p. 6, thinks that Pawnee may have had horses as early as 1630.

diverted from horticulture to buffalo hunting as a primary means of subsistence, and these included many bordering peoples that now swept into the true plains for the first time. So completely did the horse enter into and modify the scheme of Plains Indian life that not only the later explorers but also many of the ethnologists who came after them have envisioned this type of life as being ancient and universal in the region rather than a comparatively recent development.

With the fully recorded expeditions after 1804 of Lewis and Clark, Zebulon Pike, Major Long, and other American army officers and scientific observers comes the well illuminated climax of the play. With or shortly after these men came educated travelers like Brackenridge, Irving, and Prince Maximilian of Wied, naturalists like Nuttall and Bradbury, and artists such as Bodmer, Catlin, Eastman, and Kurz. In their accounts and pictures, the full historic culture of the Plains is revealed for the first time, with its special emphasis on buffalo hunting and its cult of warfare. Contrasted with the fragmentary records of the Spanish and French, these later descriptions are strikingly full and vivid and it is not remarkable that the picture of the Plains Indians as they were during the first three-quarters of the nineteenth century should eclipse all others in the popular and even in the scientific mind. Nevertheless, the student of human history in the Plains region, in the light of the scant earlier records, must bear in mind the fact that this last period was one of cultural degeneration for many of the tribes concerned.

The establishment of reservations from about 1855 on, the extinction of buffalo on the Plains, and the grim record of the Indian wars mark the tragic finale of the old Indian life. Perhaps we are still too close to these events and too conscious of the Indian as he exists today on so many reservations to appreciate fully the tremendous dramatic possibilities revealed in these closing scenes. To one who has known or who can visualize the Plains Indian of the recent past it would seem that the epic qualities of that hopeless but gallant fight against overwhelming odds have as yet been barely touched upon. Less dramatic than the Indian wars perhaps, but more important, there still remains the baffling problem of acculturation whereby this virile addition to the modern American stock may be fitted into that culture which so ruthlessly, however inevitably, supplanted the colorful life of the old buffalo plains. Such in broadest sweep is the recorded Indian history in the major area with which we are concerned.

TABLE I—A Digest of Certain Maps Showing the

Maps	Siouan linguistic stock					
	Dakota	Dhegiha Division			Chiwere Division	
		Omaha	Ponca	Kansa	Oto	Iowa
1. Marquette, 1673 (does not show Missouri R.)	(no)	SW. of Pawnee	(no)	well S. of Pawnee	just S. of Pawnee	NW. of Pawnee (?) (see Co- manche on this chart)
2. Joliet, 1674 (rivers appar- ently confused)	far to NE.	on small river suggesting Des Moines	(no)	S. of Pawnee and W. of (Missouri) R.	on (Des Moines) R. between Pawnee on N. and Illinois to S.	farthest N. on (Des Moines) R.
3. Carte de la Louisiane, 1679	(no)	far to NE. beyond Oto	(no)	well S. of Pawnee	far to NE. in (Minnesota) but Oto River in Iowa	W. of Omaha tribe
4. Anonymous French Map, circa 1697	(no)	(no)	(no)	W. of Mis- souri R. S. of Pawnee	near head- waters of Missouri R. W. of Iowa tribe	N. of Pawnee, E. of Missouri R.
5. Le Sueur's map, 1701	far to NE. ex- cept Teton and Yankton in W. Iowa (?)	on (Big Sioux) R. in (Iowa)	S. of Platte between Oto and Kansa (?)	on (Nemaha) R. and upper Kansas R.	both sides Missouri R. below Platte R.	3 locations in N. S. and central Iowa
6. De l'Isle, map of Canada and the Mississippi, 1702	(no)	(same as map 5)	(no)	on small river S. of Platte W. of Missouri	(no)	(same as map 5)
7. Carte Generale de la Louisiane ou de Miciscipi, Vermale, 1717	(no)	above Co- manche on NE. branch of Missouri R.	(no)	on Kansas R.	(no)	(no)
8. De l'Isle map of Louisiana, 1718	far to NE.	(same as map 5)	(no)	on upper Kansas R., also on "Little Kansas"	in Iowa op- posite mouth of Platte, also to E.	north of Pawnee, W. of Missouri R. (?)
9. De l'Isle, map of 1722	far to NE.	(same as map 5)	(no)	(same as map 8)	(same as map 8)	(same as map 8)
10. Bellin's map of Louisiana (in Charlevoix) 1744	far to NE.	(no)	(no)	strip across N. Kansas, that river and S. tributaries	in Iowa op- posite mouth of Platte	N. of Oto
11. Du Pratz, map of Louisiana, 1757	(no)	(no)	(no)	on Kansas R. and Missouri R. just N.	in Nebraska just S. of Platte	in N. Iowa
12. Collot's map, 1796	to N. and E.	in Nebraska opposite Sioux R.	(no)	on Kansas R.	(same as map 11)	(no)
13. Perrin du Lac, Carte du Missouri, 1802	(no)	in Nebraska just N. Sioux R.	on Ponca Creek (Nebraska)	(same as map 11)	on Platte just above Elkhorn (Yutan site)	(no)
14. Lewis and Clark, 1804	to NW. and NE.	(same as map 13)	(same as map 13)	(same as map 11)	(same as map 13)	in central Iowa
15. Pike's map, 1805	(no)	(no)	(no)	(same as map 11)	"remains of village" on Platte W. of Shell Creek	(no)
16. Long's map, 1819	N. on the Missouri R. in South Dakota	on Omaha Creek (same as map 13)	(same as map 13)	(same as map 11)	(Yutan) site on Platte	(no)

Tribes in the Region of Nebraska from 1673 to 1819

	Caddoan linguistic stock			Shoshonean	Algonkian linguistic stock	
	Arikara	Pawnee	Wichita	Comanche	Cheyenne	Arapaho
uri						
of	(no)	region of W. Iowa or E. Nebraska	just NE. of Kansa	Shea, 1861, p. 93, suggests that the "Pahoutet" of Marquette were the Padouca or Comanche	(no)	(no)
	perhaps N. group of "Pana"?	between Oto and Omaha on (Des Moines) R., also SW. of (Missouri) R. N. of Kansa	SW. of (Arkansas) R.	(no)	(no)	(no)
f	(no)	on river suggesting Platte	on dubious river SW. of Missouri R.	(no)	(no)	(no)
ne	country N. and W. of Missouri R.	on what appears to be a branch of Platte	(no)	(no)	(no)	(no)
R.						
as R.	on Missouri in (South Dakota)	12 villages on (Loup) R. 10-12 on (Republican) R.	(no)	headwaters of the Arkansas R.	(no)	(no)
isa.	possibly N. group of "Panis"	3 places: E. of Missouri R. opposite Platte; on vague r. N. of Platte and 2 villages on headwaters of Arkansas	2 places: just N. of Arkansas R. and W. of (Nemaha) R.	(no)	(no)	(n)
R.						
isa	40 villages of "Panis" on Missouri above Platte SE. of "Padouca"	many villages on Platte R. Also shown on upper Arkansas R.	probably Pawnee group shown on Arkansas River	10 villages on upper Missouri R.	(no)	(no)
	40 villages of "Panis" on Missouri in (South Dakota)	on all branches of the Platte	4 villages on middle Arkansas R.	5 villages west of Missouri near mountains, country of "Apache and Padoucas"	(no)	(no)
	(same as map 8)	(same as map 8)	(same as map 8)	"White Padouca" in N., "Black Padouca" in S.	(no)	(no)
as R.	"Panis" on upper Missouri in (South Dakota)	centering on Platte including general region N. of Kansa	on middle Arkansas R.	N. and S. group and a long strip W. of Missouri R. bordering mountains.	(no)	(no)
isa						
isa.	"Panis noirs" just east of Missouri, N. of Pawnee proper	on Platte R.	"Panis blanc" on N. branch of Arkansas	4 places W. of Pawnee "Gr[and] village" on (Solomon) R.	(no)	(no)
isa.						
isa.	on headwaters White R., ancient village near Cheyenne R. (South Dakota)	on Platte and Republican Rivers	(no)	on S. fork of Platte	at forks of Cheyenne R. (South Dakota)	(no)
vil-	near mouth of Cheyenne R., (South Dakota)	S. side Platte W. of Oto village. On Loup and Republican Rivers	(no)	"ancient village" on lake on small branch of (Niobrara) R.	(Cheyenne R., South Dakota, shown)	(no)
of						
V. of						
n R.						
at	near (North and South Dakota Line)	(same as map 13 only no one on Republican R.)	(no)	(no) mentioned in text as formerly W. of Pawnee	at forks of Cheyenne R. (South Dakota)	Ka-ne-na-vish (identified by Gatschet) on upper Platte
site						
S. of	(no)	on Loup R., on S. side of Platte above Elkhorn R. and on Republican R.	(no)	(no)	(no)	(no)
and						
te						
site	(old villages shown in North and South Dakota)	on Loup R. only, except a "Pawnee village deserted in 1820" shown where "Blue Water" enters Red R. far to SE.	SE. "Pawnee village" may be Wichita	designates south fork of Platte as Padouca	just N. of Cheyenne R. (South Dakota)	(no)
ge in						
uth						
)						

TABLE I—A Digest of Certain Maps Showing the Indian Tribes in the Region of Nebraska from 1673 to 1819

Maps	Siouan linguistic stock							Caddoan linguistic stock			Shoshonean	Algonkian linguistic stock	
	Dakota	Dhegiha Division			Chiwere Division			Arikara	Pawnee	Wichita	Comanche	Cheyenne	Arapaho
		Omaha	Ponca	Kansa	Oto	Iowa	Missouri						
1. Marquette, 1673 (does not show Missouri R.)	(no)	SW. of Pawnee	(no)	well S. of Pawnee	just S. of Pawnee	NW. of Pawnee (?) (see Comanche on this chart)	well SE. of Oto	(no)	region of W. Iowa or E. Nebraska	just NE. of Kansa	Shea, 1861, p. 93, suggests that the "Pahoutet" of Marquette were the Padouca or Comanche	(no)	(no)
2. Joliet, 1674 (rivers apparently confused)	far to NE.	on small river suggesting Des Moines	(no)	S. of Pawnee and W. of (Missouri) R.	on (Des Moines) R. between Pawnee on N. and Illinois to S.	farthest N. on (Des Moines) R.	(no)	perhaps N. group of "Pana"?	between Oto and Omaha on (Des Moines) R., also SW. of (Missouri) R. N. of Kansa	SW. of (Arkansas) R.	(no)	(no)	(no)
3. Carte de la Louisiane, 1679	(no)	far to NE. beyond Oto	(no)	well S. of Pawnee	far to NE. in (Minnesota) but Oto River in Iowa	W. of Omaha tribe	just N. of mouth of Missouri R.	(no)	on river suggesting Platte	on dubious river SW. of Missouri R.	(no)	(no)	(no)
4. Anonymous French Map, circa 1697	(no)	(no)	(no)	W. of Missouri R. S. of Pawnee	near headwaters of Missouri R. W. of Iowa tribe	N. of Pawnee, E. of Missouri R.	name alone given to Missouri R.	country N. and W. of Missouri R.	on what appears to be a branch of Platte	(no)	(no)	(no)	(no)
5. Le Sueur's map, 1701	far to NE. except Teton and Yankton in W. Iowa (?)	on (Big Sioux) R. in (Iowa)	S. of Platte between Oto and Kansa (?)	on (Nemaha) R. and upper Kansas R.	both sides Missouri R. below Platte R.	3 locations in N. S. and central Iowa	S. of Kansas R.	on Missouri in (South Dakota)	12 villages on (Loup) R. 10-12 on (Republican) R.	(no)	headwaters of the Arkansas R.	(no)	(no)
6. De l'Isle, map of Canada and the Mississippi, 1702	(no)	(same as map 5)	(no)	on small river S. of Platte W. of Missouri	(no)	(same as map 5)	S. of Kansa, W. of Missouri R.	possibly N. group of "Panis"	3 places: E. of Missouri R. opposite Platte; on vague r. N. of Platte and 2 villages on headwaters of Arkansas	2 places: just N. of Arkansas R. and W. of (Nemaha) R.	(no)	(no)	(n)
7. Carte Generale de la Louisiane ou de Mitecipl. Vernale, 1717	(no)	above Comanche on NE. branch of Missouri R.	(no)	on Kansas R.	(no)	(no)	S. of Kansa	40 villages of "Panis" on Missouri above Platte SE. of "Padouca"	many villages on Platte R. Also shown on upper Arkansas R.	probably Pawnee group shown on Arkansas River	10 villages on upper Missouri R.	(no)	(no)
8. De l'Isle map of Louisiana, 1718	far to NE.	(same as map 5)	(no)	on upper Kansas R., also on "Little Kansa"	in Iowa opposite mouth of Platte, also to E.	north of Pawnee, W. of Missouri R. (?)	mouth of Kansas R.	40 villages of "Panis" on Missouri in (South Dakota)	on all branches of the Platte	4 villages on middle Arkansas R.	5 villages west of Missouri near mountains, country of "Apache and Padoucas"	(no)	(no)
9. De l'Isle, map of 1722	far to NE.	(same as map 5)	(no)	(same as map 8)	(same as map 8)	(same as map 8)	(same as map 8)	(same as map 8)	(same as map 8)	(same as map 8)	"White Padouca" in N., "Black Padouca" in S.	(no)	(no)
10. Bellin's map of Louisiana (in Charlevoix) 1744	far to NE.	(no)	(no)	strip across N. Kansa, that river and S. tributaries	in Iowa opposite mouth of Platte	N. of Oto	on Kansas R. S. of Kansa	"Panis" on upper Missouri in (South Dakota)	centering on Platte including general region N. of Kansa	on middle Arkansas R.	N. and S. group and a long strip W. of Missouri R. bordering mountains.	(no)	(no)
11. Du Pratz, map of Louisiana, 1757	(no)	(no)	(no)	on Kansas R. and Missouri R. just N.	in Nebraska just S. of Platte	in N. Iowa	S. of Kansa, both sides of Missouri R.	"Panis noirs" just east of Missouri, N. of Pawnee proper	on Platte R.	"Panis blanc" on N. branch of Arkansas	4 places W. of Pawnee "Gr[and] village" on (Solomon) R.	(no)	(no)
12. Collot's map, 1796	to N. and E.	in Nebraska opposite Sioux R.	(no)	on Kansa R.	(same as map 11)	(no)	(no)	on headwaters White R., ancient village near Cheyenne R. (South Dakota)	on Platte and Republican Rivers	(no)	on S. fork of Platte	at forks of Cheyenne R. (South Dakota)	(no)
13. Perrin du Lac, Carte du Missouri, 1802	(no)	in Nebraska just N. Sioux R.	on Ponca Creek (Nebraska)	(same as map 11)	on Platte just above Elkhorn (Yutan site)	(no)	"ancient village" S. of Kansa, W. of Missouri R.	near mouth of Cheyenne R. (South Dakota)	S. side Platte W. of Oto village. On Loup and Republican Rivers	(no)	"ancient village" on lake on small branch of (Niobrara) R.	(Cheyenne R., South Dakota, shown)	(no)
14. Lewis and Clark, 1804	to NW. and NE.	(same as map 13)	(same as map 13)	(same as map 11)	(same as map 13)	in central Iowa	with Oto at (Yutan) site	near (North and South Dakota Line)	(same as map 13 only no one on Republican R.)	(no)	(no) mentioned in text as formerly W. of Pawnee	at forks of Cheyenne R. (South Dakota)	Ka-ne-na-vish (identified by Gatschet) on upper Platte
15. Pike's map, 1805	(no)	(no)	(no)	(same as map 11)	"remains of village" on Platte W. of Shell Creek	(no)	in Iowa S. of Grand R. and at Oto site	(no)	on Loup R., on S. side of Platte above Elkhorn R. and on Republican R.	(no)	(no)	(no)	(no)
16. Long's map, 1819	N. on the Missouri R. in South Dakota	on Omaha Creek (same as map 13)	(same as map 13)	(same as map 11)	(Yutan) site on Platte	(no)	at Yutan site (old village in Iowa mouth Grand R.)	(old villages shown in North and South Dakota)	on Loup R. only, except a "Pawnee village deserted in 1820" shown where "Blue Water" enters Red R. far to SE.	SE. "Pawnee village" may be Wichita	designates south fork of Platte as Padouca	just N. of Cheyenne R. (South Dakota)	(no)

It is not the purpose of the present paper to set forth in full detail the history of the various Indian tribes within the borders of Nebraska. Rather it is hoped that a general background may be afforded whereby the archeological findings of the prehistoric period may be linked with the cultures of known tribes or groups of tribes within the State. For this purpose it has seemed most effective to draw together and summarize a number of the more important maps showing the location of tribes in or adjacent to Nebraska during the period between 1673 and 1819 (table 1). Not all the maps for this period are included, but enough have been digested to assure a fair sampling. Hence it is improbable that any native peoples of importance occupying Nebraska within the prehistoric period have been omitted. From a study of these data it is possible to determine just which tribes actually lived within the boundaries of the State and to discuss their movements and the nature of the environment in which they lived. Some of these early maps, where widely divergent, may be in error, and where identical, may have been copied one from the other, but there can be no doubt that as a whole they show the general location of Nebraska tribes and the major movements that occurred within the period represented.

If the vertical columns of table 1 are scanned from top to bottom the locations and changes of each tribe shown on the selected maps can be traced from 1673 to 1819. As previously stated, only those tribes in or adjacent to Nebraska within historic times are included. Considering each tribe in succession from left to right, it appears first that the various bands of the Dakota can be eliminated as original residents at the start. This does not mean that certain of these groups did not penetrate into northern and even central Nebraska in historic times, a fact that is well known, but rather that they are not shown on any of these earlier maps as permanent residents within the Nebraska area. The Omaha are first shown in Nebraska by Collot in 1796, and they were certainly a Nebraska tribe within historic times. As such they will be subsequently discussed in more detail. The Ponca, save for Le Sueur's map of 1701, appear first in Nebraska on the Perrin du Lac map of 1802. They are certainly a Nebraska tribe. All maps indicate that the historic Kansa range was just south of Nebraska. Although not a Nebraskan people, they are important in relation to the general problem of Siouan migrations, as the first Dhegiha tribe to be mentioned west of the Missouri, "by Juan de Oñate, who went from San Gabriel, New Mexico, in 1601, till he met the 'Escansagues,' who lived 100 leagues to the N.E., near the

'Panana,' or Pawnee."³ The Oto, unless Marquette's vague location of them was actually in Nebraska, are first shown within that State by Du Pratz in 1757, and are a Nebraska tribe. De l'Isle in 1718 and 1722 shows the Iowa in Nebraska, but, as future discussion will indicate, they seem to have been only secondarily a historic Nebraska tribe. The Missouri are likewise only secondarily a Nebraska tribe, since they are not shown in that area prior to Lewis and Clark in 1804, at which time their remnants were affiliated with the Oto. The Arikara are consistently located north of our immediate region and need not be considered in detail at this time, though Omaha traditions claim that the Arikara were in northeastern Nebraska prior to their own occupation. Their kinsmen, the Pawnee, however, are the Nebraska tribe par excellence. From the time of Coronado until their removal to Oklahoma in 1876 they are always indicated within Nebraska, though their earlier territories extended to the south beyond the State boundary. Like the Arikara, the Wichita do not appear to have made their home within our region in historic times. The Comanche present a puzzling and fascinating problem but can certainly be included as a Nebraska tribe at some time during their historic wanderings. Not until Collot's map in 1796 are the Cheyenne indicated, and then north of our territory, in South Dakota. Since they claimed and at times occupied extreme western Nebraska in the later historic period they may be considered also as secondarily one of the tribes of that State. The Arapaho are shown solely by Lewis and Clark and then on the upper Platte, presumably in Colorado. Their history is closely linked with that of their linguistic kinsmen, the Cheyenne.

Five tribes, namely, the Pawnee, Omaha, Ponca, Oto, and Comanche, were certainly resident in Nebraska for considerable periods of time. Two other tribes, the Iowa and the Missouri, lived on the eastern border of the State for brief periods, and various bands of the Dakota as well as the Cheyenne and Arapaho in late historic times ranged over and claimed the extreme northern and western border areas. Although various tribes since the reservation period have been assigned temporarily or permanently to restricted areas in Nebraska, these need not be discussed in the present connection. Such forced or temporary visitors as the Sauk and Fox, Winnebago, and Santee Dakota, arriving in Nebraska as government wards, obviously have no direct bearing on the archeological problem at hand.

All historic evidence indicates that the Pawnee were the most firmly rooted of the native peoples in Nebraska. Their early history, traditions, and exact locations within the State have been discussed in

³ Handbook of American Indians, Bur. Amer. Ethnol., Bull. 30, pt. 1, p. 653.

detail by Wedel, and the material there set forth is basic to a considerable part of the present discussion. Certain Pawnee sites not mentioned by Wedel may be briefly referred to here. On the basis of Oto legends, Maj. A. L. Green tells of an early Pawnee village said to be located near Blue Springs, Gage County, Nebr. (Connelley, 1918, p. 444.) Likewise an abandoned village, said to have been claimed by the Kitkehahki or Republican tribe, is reported on the site of the present town of Savannah in Butler County. (Brown, 1892, p. 283.) Reference is made by Du Tisé, in 1719, to two Pawnee villages on the Grand or Neosho River in the vicinity of the Grand Saline, near the present town of Vinita, Okla.,⁴ as well as numerous Pawnee sites to the north and west. Like the "Pawnee" village on Long's map in 1818, located on the Red River, certain of these "Pawnee" sites may actually refer to their southern relatives, the Wichita. The entire matter of historic Pawnee villages in Kansas and Oklahoma should be carefully investigated, but may only be referred to here in passing. Another disputed matter is the possibility of the Skidi Pawnee ranging east of the Missouri in early historic or late prehistoric times.⁵ The De l'Isle maps of 1702 (and 1703) show a group of Pawnee east of the Missouri opposite the mouth of the Platte, but aside from this I know of little verification for their traditional location in this region. Until something more tangible is at hand it seems reasonable to regard the Pawnee as centered in the Platte and Republican River regions of Nebraska, west of the Missouri, where all historic maps and accounts place them. The general range of the Pawnee within Nebraska during historic times is indicated on the map (fig. 2). Of all the tribes discussed, the Pawnee hold the best claim to being the original Nebraskans, at least so far as the historic period is concerned.

Next in importance to the Pawnee in Nebraska were the sedentary Siouan tribes along the Missouri River. These belong to two linguistic groups or divisions of the great Siouan speech family. Of these, the larger is the Dhegiha division, to which belong the Omaha, Ponca, Qua-

⁴ Connelley, 1918, p. 443. According to Connelley there were also Tappage Pawnee villages on the Smoky Hill River in 1836. A "Panis old village" is likewise shown near the Neosho River between Saline and Spavinaw Creeks on a map of the U. S. exploring party in 1803-04, map on file, U. S. Army, Corps of Engineers, File Mark I R 20 Roll. This reference is important since the map distinguishes the Wichita or "Panis Piqués" on the headwaters of the Red (or Washita?) River. This record was called to Dr. John R. Swanton's attention by Grant Foreman, the Oklahoma historian.

⁵ Dorsey, 1886, p. 215, and Connelley, 1918, p. 443, on the basis of Dhegiha Siouan traditions believe that at one time the Skidi lived east of the Mississippi.

paw, Osage, and Kansa tribes, while the smaller or Chiwere division, according to Dorsey, is composed of the Iowa, Oto, and Missouri tribes. Both divisions have numerous traditions regarding their westward migration in rather late prehistoric times. The Dhegiha division claims to have come westward to the mouth of the Ohio River as one people. Here the Quapaw separated, going down the Mississippi while the others went up the Missouri, resolving themselves gradually into the Osage, Kansa, Omaha, and Ponca in about that order. The Chiwere group have similar traditions to the effect that they were originally one people with the Winnebago living on the Great Lakes who subsequently moved in a southwesterly direction. The languages of these tribes are actually very similar to that of the Winnebago. At Green Bay, Wis., they divided, the Winnebago remaining while the rest went on until they reached the Mississippi at the mouth of the Iowa River. Here one band, the Iowa, remained while the others proceeded to the west until they reached the mouth of the Grand River in the present State of Iowa. Here the split between the Missouri and Oto took place.⁶ The general direction of this movement and the assumed relationship of the tribes involved is corroborated in the main by ethnographic, linguistic, and historical evidence. On the other hand, the time at which the earlier movements occurred and the exact lines of migration remain obscure. There is such great variation in the traditions among the various tribes, and even between the different versions within the same tribe, that complete acceptance of any of them as regards temporal and geographic details seems impossible. Since only certain tribes of each division moved into Nebraska, these alone need be considered in detail. Of the Dhegiha group these are the Omaha and the Ponca, and of the Chiwere division, the Oto in particular, and the Iowa and Missouri secondarily.

According to Fletcher and La Flesche the name Omaha means "against the current" or "upstream" in contrast to the Quapaw "with the current" or "downstream," and was fixed prior to 1540 as indicated by De Soto's (assumed) contact with the Quapaw at that time.⁷ Omaha traditions place their original home in the east but, according to the above authorities, are vague as to their westward move-

⁶ Summed up by Swanton and Dixon, 1914, pp. 385-389.

⁷ Dr. John R. Swanton informs me that on cultural and historical grounds he strongly doubts the identification of the "Pacaha" (mentioned by three of De Soto's chroniclers) as the Quapaw. This generally accepted identification has rested mainly on the apparently inverted term "Capaha" as given solely by Garcilasso, who appears to have been the least accurate of all the chroniclers. This criticism also applies to Dorsey, 1886, p. 222.

ment, although one traditional account states that subsequent to their separation from the Quapaw they followed the Des Moines River to its headwaters and wandered to the northeast. Other traditions state that they dwelt on the Big Sioux River in bark houses but learned to make earth lodges and to cultivate maize from the Arikara, who at that time are said to have occupied the historic Omaha territory in northeastern Nebraska. Many traditional accounts indicate close contact with the Arikara in prehistoric times, but Fletcher and La Flesche doubt that maize was first introduced to the Omaha by the Arikara. The Ponca are said to have been the last of the cognate tribes to separate, leaving the Omaha on the Missouri River. Ponca traditions state that they first obtained horses from the Padouca (Comanche) and later drove these people away from their interior village. Aside from certain legends that "horses came from the southwest" the Omaha traditions are not explicit in this regard. Traditions are somewhat vague as to Omaha villages on the Missouri but several sites, extending from the mouth of the White River in South Dakota on the north, south to the Platte and east of the Elkhorn River are mentioned. (Fletcher and La Flesche, 1911, pp. 36-94.)

Dorsey gives a detailed account of Omaha migrations in which traditional and historic movements appear to be blended in a confusing fashion. In this account the united Iowa, Omaha, and Ponca are said to have moved northwest in Iowa up the Chariton River until they reached the pipestone quarries in Minnesota. It is said that they were already building earth lodges and cultivating the soil at that time. Here they were attacked by the Sioux (Dakota) and fled southwest to the Missouri River in South Dakota, ascending that stream to the mouth of the White River. The Iowa and the Omaha stayed here, while the Ponca went off to the Black Hills. The latter returned, and the three tribes then descended the Missouri on the western bank until they reached the Niobrara River, where the Ponca remained. The others crossed, and the Omaha settled on Bow Creek, while the Iowa went south and built a village on a stream near the present site of Ionia in Dixon County, Nebr. The Omaha then moved to a place near Covington, Nebr., opposite Sioux City, and the Iowa passed them and built another village just north of the present city of Omaha, where the town of Florence is now located. From this site the Iowa moved southward until they reached their reservation on the Kansas-Nebraska line. Dorsey gives a map of the traditional Omaha villages north of the Platte and east of Shell Creek which, in conjunction with similar data in Fletcher and La Flesche, should have value when work on Omaha archeology is begun. Dorsey states that the Oto were first

met by the Omaha in comparatively recent times on the Platte. He also speaks of the Cheyenne as dwelling with the Comanche in a sandy region on a great lake near the head of the Elkhorn River, neither tribe using the bow but employing darts instead. The Cheyenne are likewise said to have checked the northward advance of the Kansa near the Nebraska-Kansas State line. (Dorsey, 1886, pp. 218-222.)

It is impossible to determine the assumed period of each of these different movements from either Dorsey's account or the vague outline presented by Fletcher and La Flesche. According to the former, the traditional evidence suggests that the Ponca split from the Omaha sometime about 1390, that all migrations prior to the separation of Iowa, Omaha, and Ponca occurred prior to 1673, and that the split between Quapaw and Omaha occurred prior to 1540.⁸ Aside from the confusing problem as to the relative time of these postulated movements, Dorsey's references to the Iowa and Cheyenne do not seem to agree with the historic locations of these groups. This matter will be referred to shortly. The traditional evidence as to the Dhegiha migration gathered by Dorsey is undoubtedly significant, but only the most painstaking historical and archeological research can authenticate and clarify the picture thus presented.

From the maps here summarized (table 1) it appears that prior to 1796 the Omaha were located on the east side of the Missouri in the vicinity of the Big Sioux River. Collot's map of the above date first shows them within the territory now included in Nebraska. However, in 1801 Le Raye mentions bands of the Omaha and Ponca being associated with the Cheyenne and other tribes on the headwaters of

⁸ Dorsey, 1886, pp. 221-222. Dorsey translated the term "Pana" on Marquette's map as Ponca and this has since been generally accepted, *Handbook of American Indians*, Bur. Amer. Ethnol., Bull. 30, pt. 2, pp. 216, 278. This identification seems extremely dubious since both La Salle and Father Hennepin use the term "Pana" as though referring to one of the Pawnee tribes (Margry, 1874, II, pp. 201-202, and Hennepin, 1903, II, p. 443), while on the N de Fer map of 1718 (*Partie Meridionale de la Rivière de Mississippi*) and the Von Keulen Map of New France, 1720, the "Apana" are located between the "Panimaha" (Skidi Pawnee) and the "Paniassa" (Wichita). Wedel (no date) has tacitly assumed that Marquette's term "Pana" referred to the Pawnee and, on the evidence above cited, I am inclined to agree with him. The point is an important one and merits further research, since it has been generally stated that the Marquette reference proved the separate existence of the Ponca in 1673. Since all Marquette's locations of Missouri River tribes were based on hearsay evidence, it seems far more probable that he would have been told of the important Pawnee groups rather than a small, slightly differentiated branch of the Omaha. In the present paper I have assumed Wedel's identification to be correct.

the Cheyenne River in what is now South Dakota, all these tribes being hostile to the Dakota. (Le Raye, 1908.) This record affords some corroboration of the traditional movement postulated by Dorsey. The subsequent maps of Perrin du Lac, Lewis and Clark, and Long all show them in the northeastern corner of Nebraska. Although the Omaha had practically abandoned their territory east of the Missouri in the eighteenth century, they continued to hunt there on occasion until the middle of the next century. Their eastern territories were ceded to the United States in the treaties of 1830, 1836, and 1854. (Fletcher and La Flesche, 1911, p. 89.) In 1845 the Omaha were living to the south, a short distance above the Platte, and in 1847 the village in the forks of Papillion Creek was built. The year after the treaty of 1854 they returned north to their former home in the then newly assigned reservation in Dakota County, Nebr., where they are at the present time. (Bur. Amer. Ethnol., Bull. 30, pt. 1, p. 120; Bushnell, 1922, p. 81.)

Thus, on historic evidence alone, the Omaha may only be regarded as a Nebraska tribe since about 1796, during which time they have occupied a strip of territory extending from the Cheyenne River in South Dakota south as far as the Platte River (map, fig. 2). If the migration account given by Dorsey is to be taken literally, all the latter part of the Omaha, Ponca, and Iowa movement, from the White or Cheyenne River region in South Dakota down the west side of the Missouri, must have occurred since 1796. The fact that the Omaha were located in northwestern Iowa at the time of their discovery is, however, no proof that they may not have been in Nebraska in prehistoric times. Not only does the general westward movement of the Dhegiha group seem probable, but the location of two of these tribes, the Osage and Kansa, on the lower Missouri, and the Omaha and the Ponca farther up the same river, suggests possible movements up or down that stream. Thus the latter tribes may well have reached their prehistoric location by moving north on either or both sides of the Missouri, in which case their prehistoric villages should be located in either western Kansas, eastern Nebraska, or both regions. In any case prehistoric Siouan movements along the Missouri River seem probable from both geographic and traditional considerations, although recorded history, so far as the Nebraska area is concerned, indicates that both the Omaha and the Oto were east of the river at the time of their discovery.

From the archeological standpoint the Omaha and Ponca will probably be found to represent a single culture, although the data regarding the time when the Ponca separated from the Omaha are very

contradictory. According to Dorsey it occurred as far back as 1390; McGee thinks it probably took place about the middle of the seventeenth century; and Fletcher and La Flesche imply that it was relatively late, though they are not specific.⁹ Jean Baptiste Monier is said to have "discovered" the Ponca in 1789 (Shine, 1914, p. 21), but the name "Puncas" appears on Le Sueur's map of 1701, though the location there given as south of the Platte between the Oto and Kansa seems open to question. As previously mentioned, Le Raye reported bands of the Ponca in the region about the headwaters of the Cheyenne River in 1801. In 1802 Perrin du Lac locates them on Ponca Creek in northeastern Nebraska, and the subsequent maps of Lewis and Clark and Long do the same. The traditional accounts of the Ponca migration to the north, on the west side of Missouri, are supplemented by the Rev. A. L. Riggs, who was told by members of the tribe that their ancestors formerly dwelt east of the Mississippi and that subsequently they inhabited the country on the north side of the Missouri near its mouth, later following up that river to the north in company with the Omaha. (Dorsey, 1886, pp. 214-215.) History therefore records the Ponca as a Nebraska tribe from the beginning of the eighteenth century (map, fig. 2), but the time of their separation from the Omaha, their actual locations, and the authenticity of their migration legends must be determined by future historical and archeological research.

Of the Chiwere tribes the Oto are the most closely affiliated with Nebraska, though they were a wandering group as the following quotation from McGee indicates:

According to Winnebago tradition, the [Chiwere] tribes separated from that "People of the parent speech" long ago, the Iowa being the first and the Oto the last to leave. In 1673 the Oto were located by Marquette west of the Missouri River [sic] between the fortieth and forty-first parallels; in 1680 they were 130 leagues from the Illinois, almost opposite the mouth of the Miskoncing (Wisconsin), and in 1687 they were on Osage river. According to La Hontan they were, in 1690, on Otontas (Osage) river; and in 1698 Hennepin placed them ten days journey from Fort Crève Coeur. Iberville in 1700 located the Iowa and Oto with the Omaha, between Wisconsin and Missouri rivers, about 100 leagues from the Illinois tribe; and Charlevoix, in 1721, fixed the Oto habitat as below that of the Iowa and above that of the Kansa on the western side of the Missouri. Dupratz mentions the Oto as a small nation on the Missouri river in 1738, and Jefferys (1761) described them as occupying the southern bank of the Panis (Platte) between its mouth and the Pawnee territory; according to Porter, they occupied the same position in 1829. The Oto claimed the land bordering the Platte from their village to the mouth of the

⁹ Dorsey, 1886, p. 219; McGee, 1897, p. 191; Fletcher and La Flesche, 1911, p. 78.

river, and also that on both sides of the Missouri as far as the Big Nemaha. In 1833 Catlin found the Oto and Missouri together in the Pawnee country; and about 1841 they were gathered in four villages on the southern side of the Platte from 5 to 18 miles above its mouth. In 1880 a part of the tribe removed to the Sac and Fox reservation in Indian Territory where they still remain; in 1882 the rest of the tribe, with the remnant of the Missouri, emigrated to the Ponka, Pawnee and Oto reservation in the present Oklahoma, where in 1890 they were found to number 400.¹⁰

According to Major Green, the earliest reports concerning the Oto in about 1634 locate them in the Blue Earth region, Minnesota. Later accounts place them on the Des Moines River in Iowa and finally in the region of the Platte and Weeping Water in Nebraska. He quotes Chittenden to the effect that as far back as the middle of the eighteenth century the Oto dwelt on the banks of the Platte about 40 miles above its mouth. (Green, 1930, pp. 176-177.) In 1700 Le Sueur makes the Oto appear as almost omnipresent, since his map locates them in southwestern Iowa and on the Platte, and his account speaks of the Blue Earth River region in Minnesota as the country of the Western Sioux, the Iowa, and the Oto, although he states that the Iowa and the Oto have just gone to establish themselves on the side of the Missouri River in the neighborhood of the Omaha. Both the Iowa and the Oto are reported as cultivating the soil diligently. (Shea, 1861, pp. 101-107.) However, for a supposedly sedentary tribe, the Oto seem to have been on the jump, since they are said to have been in southern Minnesota, southwestern and northeastern Iowa, and east-central Nebraska all in the same year. Undoubtedly, various bands of the Iowa and Oto are referred to, but the record is interesting, since it shows the general state of flux then prevalent among the Siouan tribes of the Missouri River region.

Our selected series of maps (table 1) indicate that prior to 1701 the Oto were for the most part residents of northern Iowa and southern Minnesota. The earlier maps of Marquette and Joliet locate them south of the Pawnee ("Pana") and apparently somewhere near their later historic range, but these very general locations, based on extremely incomplete geographic knowledge and hearsay evidence, cannot be taken too literally. De l'Isle in 1718 and 1722, as well as

¹⁰ McGee, 1897, p. 195. I can find no verification for McGee's and Dorsey's (1886, p. 214) statements, that Marquette positively located the Oto west of the Missouri River (see French, 1850, and Shea, 1852, p. 39). On his map Marquette omits the upper Missouri entirely, while the map of Joliet, though it omits the name "Pekitanonii" or Missouri, locates the Iowa, Omaha, Pawnee ("Pana"), Oto, and certain Illinois tribes in order from north to south, along a small river to the east of the large river corresponding to the lower Missouri on Marquette's map.

Bellin in 1744, place them on the east side of the Missouri across from the mouth of the Platte. Du Pratz, 1757, locates them in Nebraska south of the Platte, and the later maps all show their main village on the Platte above the mouth of the Elkhorn, close to the modern town of Yutan. In 1835 the Oto built a new village only 6 miles above the mouth of the Platte. (Merrill, Samuel P., 1892, p. 158.) From the historic evidence it thus appears probable that from about 1670 to 1744 the Oto range was mainly in Iowa, during which time they were in close association with the Iowa tribe, and that between 1701 and 1757 they had shifted west, settling on the Platte in Nebraska, thus coming under the influence of the Pawnee (fig. 2). A priori, one would expect the material culture of the Oto, as revealed by archeology, to be very similar to that of the Iowa and probably to that of the Ponca and Omaha. In future archeological research it must be borne in mind that such late sites as the village near Yutan will probably show strong Pawnee influence; hence if earlier historic sites in southeastern Nebraska or in Iowa can be located, a more typical culture would be expectable. At the time of this writing no documented historic sites of either Oto, Omaha, Ponca, or Iowa have been excavated by scientists in Nebraska; hence the archeological characteristics of this occupation on the eastern border of the State are as yet entirely unknown.

The two remaining tribes of the Chiwere group to be associated with Nebraska, namely, the Missouri and the Iowa, may be dealt with briefly. All our maps prior to 1804 show the Missouri tribe well to the south of the Nebraska-Kansas boundary. Following their crushing defeat by the Sauk and Fox and their allies, which took place about 1700, the remnants of the Missouri affiliated with the Osage, Kansa, and Oto. In 1804, Lewis and Clark found a number of Missouri living with the Oto at the Yutan site. Later, in 1839, when the Oto were living just above the mouth of the Platte, the Missouri group established another village across the river. When the Oto went to their Oklahoma reservation in 1882, they were accompanied by the Missouri. (McGee, 1897, p.195; Merrill, Moses, 1892, p. 176.) Thus the Missouri may be regarded as a Nebraska people only after the breakdown of their own tribal life and their affiliation with the Oto. The Iowa present a somewhat more complex problem. From the concrete data at hand this tribe does not seem to have permanently occupied or claimed any major portion of Nebraska within the historic period, though they undoubtedly had villages and camps on the west side of the Missouri River at various times. Our maps from 1673 to 1697 show them in the region of northern Iowa and southern Minnesota, whereas the later maps locate them in various parts of the State

which bears their name. Of the maps included in table 1 only the De l'Isle maps of 1718 and 1722 locate any of their bands west of the Missouri. However, in the period 1832-1840 the Iowa seem to have been frequent visitors around the mouth of the Platte. (Merrill, Moses, 1892). They were settled on the Nemaha reservation on the Kansas-Nebraska line in 1836, and later part of the tribe moved to Oklahoma. (Bur. Amer. Ethnol., Bull. 30, pt. 1, p. 613; Skinner, 1926, p. 191.) Thus within the historic period they have ranged through southern Minnesota, Iowa, and northern Missouri, and have often penetrated the eastern boundaries of Nebraska, though there seems to be no positive evidence of any long residence within the latter State.

Opposed to this conclusion is the traditional evidence concerning the Iowa as given by Dorsey and apparently confirmed by Fletcher and La Flesche (1911, pp. 36-94; also see Will and Hyde, 1917, p. 40) which recounts a southerly movement of undetermined duration through eastern Nebraska with Iowa villages near the present towns of Ionia and Florence. More exhaustive historical research than is possible in a summary account may verify these details, which have already been accepted as substantially correct by other authorities.¹¹

It appears to the present author, however, that the whole problem regarding the recorded and traditional movements of the Chiwere and Dhegiha as well as other Siouan tribes should be critically examined once more. This would involve a complete concordance of all the various migration legends of these tribes and a thorough compilation of the source material on the historical aspects of the problem. Such a study of the two former groups would in all probability indicate early documented sites which could be excavated, thus revealing the actual culture horizon or horizons to be assigned to the so-called sedentary Siouan occupation of the Missouri River region. Only when this has been done can the ethnological data already obtained from these tribes be properly evaluated and understood or any objective approach to their prehistory be begun.

As the evidence now stands a cursory study such as the present one reveals two pictures: one of the brief historic occupation (or re-occupation) of Nebraska by Dhegiha and Chiwere tribes entirely within the eighteenth century, and another picture, almost equally impressive but vague and contradictory, being based on traditional evidence, which suggests the movement of Siouan peoples up and down the Missouri River through eastern Nebraska and western Iowa for

¹¹ Bur. Amer. Ethnol., Bull. 30, pt. 1, p. 612. Also Skinner, 1926, p. 191, apparently without further examination.

many centuries prior to the dawn of history in the region. We will have occasion to refer to this important problem in our concluding sections.

Leaving the Siouan peoples temporarily, we find one tribe of the Shoshonean linguistic stock resident at an early time in west-central Nebraska, namely, the nomadic and warlike Comanche. Nearly all of the maps showing the Nebraska region prior to 1804 locate the "Padouca" somewhere to the west of the Missouri River. The "Padouca" are generally believed to have been the Comanche, but this identification has been disputed by George Bird Grinnell, who thinks they may have been the Jicarilla Apache.¹² The main evidence for the latter identification seems to rest on the fact that the French designated Villazur's Jicarilla Apache allies as "Padouca" in their accounts of the expedition and the subsequent massacre of the Spanish force in 1720. It is significant that the De l'Isle map of 1718 (table 1) designates five villages in what is now western Nebraska and Kansas by the term "Apache and Padouca", indicating that the French at this time either confused these two nomadic peoples or else considered them as linked in some way. On the other hand it is clear that such Siouan peoples as the Ponca and Omaha used the word "Padouca" in reference to the Comanche,¹³ and that in general such an identification of the term is correct. Grinnell has clearly shown, however, that the term was often loosely used and where employed in early accounts must be carefully checked before being applied to any specific tribal group. In table 1 the "Padouca" or Comanche are first located on the headwaters of the Arkansas by Le Sueur in 1701, although it has been suggested by Shea that the "Pahoutet" of Marquette were the Padouca or Comanche.¹⁴ In 1717 ten of their villages are shown on the upper Missouri River; De l'Isle in 1718, as mentioned above, locates five villages of "Apache and Padoucas" west of the Missouri near the mountains; in the De l'Isle map of 1722 a "White Padouca" group in the north and a "Black Padouca" group in the south are distinguished. Bellin in 1784 distinguishes a north and south group occupying a long strip of country bordering the mountains, and Du Pratz in 1757 shows them in four places west of the

¹² 1920, pp. 248-260. There are many valuable references in this paper to early tribal names and synonyms.

¹³ Fletcher and La Flesche, 1911, p. 79. The term is probably derived from the Pénätēka division of the Comanche, who were the first to move south.—Mooney, 1898, p. 162.

¹⁴ Shea, 1861, p. 93. However, Le Sueur's map shows the "Aiaouez ou Paoutez" and the Padoucas as distinct groups.

Pawnee, with their "Grand Village" on what I would presume to be the Solomon or Smoky Hill Rivers in Kansas.¹⁵ Collot in 1796 locates the "Padouca" on the south fork of the Platte, and Perrin du Lac 6 years later indicates an "ancient village" on a lake drained by a small branch of the Niobrara (?) River. The maps of Lewis and Clark and of Pike do not indicate either the Padouca or Comanche. The former authorities mention the "Cataka" or "Cat-a-kah" as a group of the "Paducar" who came to trade at the Arikara villages on the upper Missouri.¹⁶ Zebulon Pike states that the "Comanches" were called the "Padoucas" by the Pawnee,¹⁷ but it is not altogether clear from his references whether the people called "Tetaus" or "Ietans" were identical or separate from the Comanche. Long in 1819 designates the south fork of the Platte as the "Padouca" but elsewhere (1823, II, pp. 116, 187) he refers to the Kiowa, Kaskaias (Kiowa Apache?), Arapaho, and Cheyenne as being collectively known as the "Padoucas," whereas the "Camancias" are referred to as a separate tribe. Obviously the term "Padouca" had come to be used for a number of nomadic buffalo-hunting tribes that occupied the central and southern plains at a relatively late period. However, the use of this term by other tribes and by the earlier explorers and cartographers seems generally to have signified the Comanche. Considering that the ethnology, history, and archeology of the Comanche have all been woefully neglected it seems futile until more explicit data are at hand to do more than point out that they did occupy central Nebraska in the early historic period, apparently coming from the north and west and leaving toward the south. In a later section we will have occasion to refer briefly to the problem thus presented.

Of the Algonkian linguistic stock at least two and probably three tribes moved through and to a certain extent occupied western Nebraska within historic times. These were the Cheyenne, the Arapaho, and the Sutaio, the last originally neighbors of and later incorporated with the Cheyenne. On Lewis and Clark's map this last group is designated as the "Sta-e-tan" and located near the headwaters of the White River in South Dakota (table 1). A fourth group, the Atsina, were originally associated with the Arapaho but moved northwest, later joining the Blackfoot. The Arapaho appear to have once been in the region of northern Minnesota, moving west about

¹⁵ Connelley, 1918, p. 454, and Grinnell, 1920, p. 248, locate this village on the Smoky Hill River.

¹⁶ 1904, I, p. 190. The Handbook of the American Indians, Bur. Amer. Ethnol., Bull. 30, pt. 2, p. 1037, however, identifies Cá takâ as Kiowa Apache.

¹⁷ Coues, 1895, III, p. 536; also see Grinnell, 1920, pp. 256-257, in this regard.

the same time or earlier than the Cheyenne and, after crossing the Missouri, drifting south. In 1801 Le Raye locates the Arapaho as the "Gens-di-rach" or "Gens de valch," i. e., "people of the buffalo", on the headwaters of the Cheyenne River in association with the Cheyenne and other enemies of the Dakota. On Lewis and Clark's map (table 1) they appear as the "Ka-ne-na-vish," then located on the upper Platte in the general region of western Wyoming. None of our other maps shows the Arapaho. Throughout the later historic period they were closely associated with the Cheyenne. The Cheyenne were first reported in the region of southeastern Minnesota, where they were visited by Carver in 1766 and were mentioned by Mackenzie on the plains of eastern North Dakota in 1790. (Grinnell, 1918, p. 359; Mooney, 1907, p. 372.) Between 1740 and 1790 at least two groups of Cheyenne had been driven out of villages on the Sheyenne River by the Chippewa according to the accounts of Henry and Thompson. Later they had villages on the Missouri River.¹⁸ Collot's map of 1796 shows Cheyenne villages at the forks of the Cheyenne River, South Dakota, and Lewis and Clark in 1804 show them at the same place (table 1). According to Alexander Henry, the younger, in 1806 the Cheyenne moved south from the Black Hills in winter and north to the Missouri in the spring. (Mooney, 1907, p. 375.) Grinnell (1918, p. 380) states that the Cheyenne still farmed on the Missouri until 1833, when the majority of the tribe took up a wandering life to the south, though the Sioux claim that the Cheyenne had penetrated far to the west 150 years before. In 1819 Major Long met part of the Cheyenne and Arapaho associated with various other tribes south of the Nebraska territory and in 1843 Fremont visited a camp composed of 100 Arapaho and 25 Cheyenne lodges located in southeastern Colorado on the South Platte near the Nebraska line. His map indicates the Cheyenne-Arapaho range in southeastern Wyoming and eastern Colorado.¹⁹ Both the Arapaho and the Cheyenne split into two divisions, a northern and a southern, about 1835. These divisions were formally recognized in the treaty with the United States in 1851. Thus the various bands and divisions of both tribes sporadically occupied and claimed the southwestern corners of what is now Nebraska, at least during the first half of the nineteenth century (map, fig. 2). No archeological research in either Arapaho or Cheyenne sites has been reported from Nebraska or Colorado, and what the material traces of their apparently brief occupation may be are unknown.

¹⁸ Mooney, 1907, p. 367; Swanton, 1930, pp. 156-159; Grinnell, 1918, p. 359.

¹⁹ Long, 1823, II, p. 187; Fremont, 1845, p. 29.

One more division of the Siouan stock remains to be discussed. This includes the various bands of the Teton Dakota, namely, the Oglala, Brulé, Blackfoot,²⁰ Miniconjou, Sans Arc, Two Kettle, and Hunkpapa, comprising the western and principal part of the Dakota proper. With the eastern Dakota bands, since they were not historically resident in the Nebraska region, we are here little concerned. In 1680 Hennepin placed the home of the Tetons west of the other Dakota bands on the upper Mississippi, and Lahontan also lists them as an upper Mississippi tribe.²¹ In general the Dakota seem to have been more or less driven out of their former woodland habitat by the Chippewa, who were the first to get guns from traders.²² Although the Dakota movement toward the prairies may have begun slightly prior to white contacts it was certainly accelerated by the advent of both firearms and horses. Le Sueur's map of 1701 shows Teton and Yankton bands just east of the Missouri River in western Iowa (table 1). If this location is reliable the western Dakota must occasionally have penetrated Nebraska even at this early date. The first record that I have encountered of the Dakota being west of the Missouri is La Vérendrye's reference in 1743 to a band of "twenty-five lodges of the *Gens de la Flèche Collée*, otherwise known as the Prairie Sioux," which he met somewhere west of the Missouri River in what is now South Dakota, apparently near the Cheyenne River.²³ According to Lewis and Clark, French traders had been on the upper Missouri for 20 years before their own advent and we have the record of Le Raye who in 1801 was captured by a band of Brulé Sioux or Dakota in northern Missouri and traversed parts of Kansas, Nebraska, and the Dakotas with his captors.²⁴ Thus the Dakota already appear to have carried their raids far afield and had undoubtedly traversed

²⁰ Not to be confused with the Blackfoot tribe belonging to the Algonkian linguistic stock who, contrary to Blackman's supposition (1903, pp. 317-325), are not known to have ever occupied Nebraska.

²¹ Bur. Amer. Ethnol., Bull. 30, pt. 1, p. 376; pt. 2, p. 736. Contrary to the statement in the last citation, I can find no evidence that Hennepin actually encountered the Teton; rather he seems to have been with the Issati, i. e., Santee, during his enforced visit. (See Shea, 1852, pp. 112-131.)

²² Swanton, 1930. Swanton adds that this Dakota movement was also the result of attractive as well as repulsive forces, i. e., horses and buffalo hunting lured them to the west, while enemies with guns pressed them from the rear.

²³ Burpee, 1927, p. 429. The French term for the Dakota here used is of ethnological interest. La Vérendrye's record was called to my attention by Dr. J. R. Swanton.

²⁴ Le Raye, 1908. This is an exceptionally interesting though brief account, both of conditions on the Missouri at the time and for the ranges and habits of numerous tribes. He mentions Crow earth lodges.

portions of the Nebraska region considerably prior to 1800. Lewis and Clark had trouble with various Teton bands and describe them in very uncomplimentary terms. Their map locates a Yankton Dakota village near the mouth of the James River and several bands of Tetons along the Missouri above the mouth of the White River in what is now South Dakota. Major Long's map, in 1819, shows a Yankton camp at the mouth of Floyd River and also shows Teton Dakota villages on the Missouri north of the White River. In 1842 Fremont locates the "Sioux" between the north and south forks of the Platte close to the Laramie plains (1845, map), and throughout the nineteenth century various bands of Dakota seem to have dominated all of northern and northwestern Nebraska. Although they seem never to have been permanent residents of Nebraska in the sense that the Pawnee were, they must certainly be listed as a Nebraskan tribe at least subsequent to 1800, during which period they raided and hunted through the region, harassing the Pawnee and the more settled Siouan peoples along the Missouri.

With the Dakota we conclude the list of known tribes that occupied or claimed any large portions of Nebraska within the realm of recorded history. Undoubtedly other tribes had camps in or passed through our region, as did the Kiowa about 1815,²⁵ but it is beyond the bounds and the needs of the present work to list the comings and goings of all the Plains tribes in that period of flux just prior to and during the Indian wars. Our brief survey has clearly indicated that of all its known inhabitants only the Pawnee were surely in Nebraska when the first white men came, that the Ponca, Omaha, and Oto have the next best claim to long residence, and that the Comanche, Arapaho, Cheyenne, and Dakota were either relatively late or were transitory occupants. Whether the Ponca, Omaha, and Oto or other Siouan tribes ever occupied eastern Nebraska prior to the dawn of recorded history is a problem for the future. From the fragmentary historical evidence at our disposal it can be demonstrated that the last two tribes, at least, crossed the Missouri within the historic period, but the nature of their distribution and of their traditions makes it possible that this was a reoccupation rather than the first appearance of Siouan peoples upon the Nebraska scene. Here is a problem for the archeologist, assisted by the ethnologist and the historian.

²⁵ Mooney, 1898, p. 168, records a Kiowa camp at the junction of Horse and Kiowa Creeks in extreme western Nebraska at this time. Also see his map, pl. 73.

THE ENVIRONMENTAL SETTING

Although the foregoing section has presupposed considerable familiarity with the surface geography of Nebraska and immediately adjacent regions, it seems necessary to proceed somewhat farther in visualizing the area from the standpoint of human ecology. The historic Indian culture of the Great Plains of North America is often cited as a particularly good example of cultural uniformity resulting from a vast but very similar environmental background marked by no important natural barriers to hinder amalgamation. The problem at once arises as to whether this late uniform culture is the result of cultural accidents, such as the acquisition of the horse and the pressure of an alien population from the east, or if its cause might be truly environmental. Lacking any actual historical insight into the prehistory of the Plains, the environmental explanation seems at present to have gained the ascendancy. As archeological research proceeds in this area we can at last begin to check general theory against actual fact. If the prehistoric cultures can be demonstrated as possessing the same general uniformity which the historic Plains tribes shared, late cultural factors can be ruled out and the role of the environment as a direct cultural determinant be defined. But if a more complex prehistoric picture is thus presented, it would seem that cultural causes must be sought, not only for the more or less uniform historic pattern but for the varied prehistoric manifestations as well. Thus the Great Plains, as has long been recognized, constitute a unique and splendid laboratory for the study of man in relation to his environment. Few major physiographic areas of the world have received and are receiving such thorough geologic, paleontologic, and geographic study, and of no similar area is so much already on record concerning the native nonindustrialized mode of life characteristic of its aboriginal inhabitants. As we trace the human record of the Plains back toward its beginnings, which, incidentally, appear to recede in a remarkable manner as we approach, we deal with a section of human history pregnant with possibilities for distinguishing major trends and determinants of human cultural development. Such major correlations and conclusions, however, are for the future. At present, from the anthropological standpoint, we know a great deal about the ethnology of the northern plains, less about that of the southern plains, and practically nothing concerning the prehistory of either section.

If the territory of some 77,500 square miles comprising the State of Nebraska is considered in relation to the rest of the United States solely on the basis of structure, it falls entirely into one major physical

division termed the Interior Plains.²⁶ The Interior Plains, however, are divided into two provinces within the State. The first of these is the Central Lowland, of which only the eastern fringe extends into Nebraska, including a rather uniform glaciated strip about 60 miles wide extending the length of the State just west of the Missouri River. In Kansas, and again in South Dakota, this strip is clearly set off from the Great Plains proper by an east-facing escarpment which in Nebraska is lacking owing to the thick mantle of loess. The line, however, follows the western edge of the glacial drift throughout the State. Characteristically, the Central Lowland consists of maturely to submaturely dissected till plains which are relatively low and flat, with streams not far above their base level. To the west there is usually a rise of a few hundred feet, beyond which the streams are actively dissecting, but in Nebraska, as just stated, this clear surface indication does not occur. The greater part of the State, however, falls into the Great Plains province, owing to the active dissection of the streams and the pleateaulike character of the central and western terrain. This terrain has a marked slant to the east, which reaches its highest point of 5,250 feet on the western border in Kimball and Banner Counties and its lowest dip in the southeast corner near Rulo, where the altitude is only 900 feet. There are three sections or subdivisions within the Great Plains province which either include large portions of or touch upon Nebraska. Three-fourths of the State, including the central and western sections, is included in what the Fenneman classification terms the High Plains. This large area is the remnant of the originally smooth plain caused by Tertiary deposits which once stretched from the mountains to the eastern edges of Kansas and Nebraska. Although it has been somewhat dissected by streams, the intervening areas are truly residual plains. To the south is an area from which the Tertiary mantle has in large part been eroded and which is dissected by streams but not yet reduced to the low level of the Central Lowland province. This is considered as the Plains Border section of the Great Plains province and, in Nebraska, comprises a narrow strip along the southern border between Furnas County on the west and Thayer County on the east, extending hardly more than 60 miles north from the Kansas-Nebraska line. The Missouri Plateau, comprising the third division or section of the Great

²⁶ For the main physiographic divisions of Nebraska see Fenneman, 1928, pp. 309-322 and map. For the specific physical geography of Nebraska, Condra, 1906, and Condra and Keyser, 1908; and for biotic zones and descriptions, R. H. Wolcott in Shelford, 1926, pp. 519-524. The present section has in the main been summarized from these sources.

Plains province, takes in only the extreme northwestern and northeastern corners of Nebraska. This is a rather rough, unglaciated area, consisting of old plateaus, tablelands, local bad lands, and isolated mountains. It is an area of profound degradation which in some places has been at least several thousand feet. Such are the major physiographic divisions occurring within the State.

Considering Nebraska by itself and taking in other factors, rather than limiting the consideration to local structure in relation to larger physiographic units, it appears that three, and possibly four, main geographic areas are to be distinguished. These are the Loess Region, which may or may not be separated from the glaciated area just west of the Missouri River; the High Plains, which include only the western portion of the region thus designated in the Fenneman classification and may here be considered as taking in the localized Bad Lands; and the central Sand Hill area. For present purposes we will consider these as four areas, extending from west to east as follows, the High Plains (including the Bad Lands), the Sand Hills, the Loess Plains, and the Glacial Area (map, fig. 2). These in turn correspond rather closely with the five biotic regions distinguished by Wolcott, which, in the same order, are the (short grass) plains region (plus the isolated coniferous woodland regions); the sand-hill region; the prairie region (tall grass prairie); and the Missouri River bluff region. Although these last may not completely overlap with the four biotic regions listed above, the correspondence is close enough for general consideration. It is difficult for one whose impressions of Nebraska may have been gained solely by passing through the cultivated loess plains on the train, to realize that the monotonous "rolling foothills of Nebraska" represent only a limited portion of that great State's surprisingly varied topography. A preconceived idea of the plains region generally as constituting a uniformly monotonous environment will be rudely jarred by traversing the rough and picturesque mesa and bad-land areas of western Nebraska or the mountainous and pine-clad regions in the northern part of the State. All these variations in topography, flora, and fauna must have had an effect on the aboriginal populations subjected to them. We will briefly sum up the salient characteristics of each, later checking up to see whether the distribution of the historic Nebraska tribes shows any definite alignment with such natural areas.

The High Plains comprise an area of over 16,000 square miles of gravel, sand, and clay deposits, with a rather low annual rainfall of 15 to 20 inches. Originally formed by wash from the mountains to the west, they have been eroded, owing to their high altitude, by numerous

swift rivers and streams such as the North Platte, Niobrara, White, Pumpkin, and Lodgepole. These have formed numerous troughs or valleys, of which that of the Platte is the largest and deepest. In between these troughs are the most elevated portions of the State, comprising the still undissected High Plains surface. In places large areas such as the Cheyenne and the Box Butte plains have retained this old high surface; elsewhere rough hills and prominent buttes project from the eroded areas as remnants of the old level. The Pine ridge on the north edge of the Box Butte plains and the Wildcat range between the North Platte and the Pumpkin are striking examples of the latter, at the same time indicating by their intricate and steep-walled canyons and sheer flanks the destructive power of the forces of erosion. Although different in composition and form, the true Bad Lands of northwestern Nebraska, which are an extension to the southwest of the Dakota Bad Lands, present much the same general appearance as do the eroded buttes and tablelands to the south.

The High Plains region in general may be characterized as a short-grass country with grama grass, buffalo grass, and various grasslike sedges predominant. Along the rougher portions are scattered yellow pines which on the Pine Ridge and similar areas are numerous enough to form small coniferous woodlands. The pines occur on the canyon walls and talus slopes, and willows and cottonwoods flourish on the bottom lands and wherever surface or subsoil water is available. In between such areas extend the rather flat, open plains marked by low shrubs in sheltered places, some sagebrush, yucca, and a few small species of cactus. The buffaloberry, wild plum, wild cherry, currant, gooseberry, and sand cherry are among the edible native products of the region. Much of the limited rainfall is absorbed by the shallow water table, but there is some run-off after heavy storms. Certain streams, being fed by springs, are continuous throughout the year and in their deep canyons are occasional small ponds and marshes resulting from the work of beavers. Of the larger streams the North Platte, fed by mountain water, as well as the spring-fed branches of the Loup and the Dismal Rivers, are continuous at all seasons. The soils of greatest distribution in the High Plains region are close-textured, sandy, and alkaline. Although they are fertile and readily cultivated, they do not produce ordinary late-maturing crops, owing to the lack of precipitation. Native to the region were large numbers of buffalo, prong-horn antelope, and mule deer. In addition, the coyote, kit fox, badger, beaver, black-footed ferret, striped ground squirrel, prairie dog, white-tailed jackrabbit, and smaller rodents are still abundant. In the limited coniferous woodland areas occur such forms as the yellow-

haired porcupine, wolverine, northern plains skunk, wood rat, red squirrel, and numerous species of small rodents. Prairie chickens, sharp-tailed grouse, and migrating water fowl must also have furnished a considerable item in primitive household economy. In general the picturesque High Plains in Nebraska offered considerable inducement to hunting peoples, whereas from the horticultural standpoint they would seem to possess less obvious advantages than as now. At the present time the region is rather sparsely settled in comparison with the eastern and southern portions of the State, excepting, of course, the even more scantily occupied Sand Hills region immediately to the east.

The Sand Hills, or more technically sand dunes, in central Nebraska occupy a broad, rather poorly defined area of some 18,000 square miles (map, fig. 2), not including isolated dune areas on the lower Loup and south of the Platte. The area is rather generally covered with shifting wind-blown sand dunes ranging from 25 to 100 feet or more in height. In between occur valleys, marshes, and especially in Cherry County, numerous lakes. The river valleys here have few tributaries and are mainly spring-fed, though a few smaller streams occur on the eastern margin. The water table is variable in depth and most of the drainage is underground, thus accounting for the lakes and marshes. It is a thin grass country supporting a considerable number of varieties of bunch grass, although some 20 acres are said to be necessary to support a single horse or cow. Yucca, sagebrush and small cacti are characteristic, and wild plum, wild rose, dogwood, and greasewood thickets are to be found in the more sheltered pockets. Raspberries, wild plums, and sand cherries are abundant. Waterfowl breed in all the lakes and even today are still very numerous. Prior to the advent of the white man and the automatic shotgun they must have bred here in tremendous numbers. Many of the animal species mentioned as occurring in the High Plains are found in the sand hills as well, though it seems improbable that the main buffalo herds would voluntarily have left the rich pasturage of the Loess Plains or even the High Plains for the more barren sand hills. Travel is difficult in the region, owing to the large areas of shifting sand, fuel is hard to obtain, and the dune-sand soil is not well adapted for farm crops. Water and grazing are adequate for stock raising, however, and this constitutes the main occupation of the very thin present-day population. We will have occasion subsequently to present a somewhat more intimate picture of the sand-hill region (see p. 212, "Surface Sites on the Dismal River, Hooker County").

The Loess Plains, or the "tall grass prairie," include a large area comprising something more than the entire southern half of the State. Originally, the entire region was covered by a dense sod with a grass cover 1 to 3 feet in height, of which bluestem, prairie, and spear grasses were the most abundant species. Beyond the boundaries of Nebraska the tall grass prairie extended into Iowa and Missouri to the east and Kansas to the south. In the former State the region is drained by large rivers such as the Republican, Big and Little Blue, and Platte River system. These rivers flow through broad valleys having extensive bottom lands and flood plains marked by alluvial benches and terraces above them. The soil of all these riparian areas is exceptionally rich and fertile and at present produces great crops of corn and winter wheat. Characteristically, the Loess Plains are rolling and open between the river valleys, presenting vast vistas in all directions. In the west, however, steep-walled ravines are common. Elsewhere, along the Republican River especially, are great loess bluffs over 100 feet in height, but in certain places the loess mantle has been removed by natural forces of erosion, revealing the underlying Dakota sandstone or Pennsylvanian limestone. This was the heart of the old buffalo range, and here the incredibly numerous herds had almost unlimited pasturage. Of the smaller mammals, elk, deer, antelope, wolves, coyotes, badgers, beaver (along the streams), and numerous small species occurred. The soils of the Loess Plains as a rule are deep, fertile, and (once the prairie cover has been removed) easily cultivated. In addition to the loess which forms the subsoil of most of the uplands and the alluvial soil of the bottom lands, there are several additional kinds of soil, each with a local distribution. In the eastern part the annual rainfall is sufficient for crop production, though it decreases to only 17 inches in the west. Similarly, the run-off is greater in the east than in the west. Except on the western portion of the plains trees grow well but under natural conditions the native timber followed the waterways. Cottonwoods, oaks, elms, willows, ash, box elders, and walnut are the main species. The grass grows higher in the east than in the west, but pasturage can be obtained on the wet flood plains, rougher grounds, and drier uplands as well. This region and the Glacial Area along the Missouri are the most thickly settled portions of Nebraska at the present time. They likewise would seem to have offered greater inducements for aboriginal occupation.

Much that has been said regarding the Loess Plains applies equally well to that region along the eastern border of Nebraska next to the Missouri River, here designated as the Glacial Area. Throughout the glacial area the loess mantle also occurs, and high loess bluffs are char-

acteristic along the western bank of the Missouri. However, all this eastern region has been subjected to direct glacial action as well, though the loess has covered the majority of the glacial deposits. In a few places in the southern portion, however, large numbers of glacial boulders are exposed on the surface. Elsewhere these are usually visible only where loess and till have been cut through or removed by water action. Back from the Missouri River, Loess Plain conditions prevail, but along the eastern border (corresponding to the Central Lowland of the Fenneman classification) are the wooded bottom lands and bluffs of the Missouri River and the lower portions of its tributaries. Here are broad-leaf forest and thicket communities, and the rivers with their shifting sand bars, flood plain thickets of young cottonwoods and willows, bottom lands with their tall cottonwoods, cut-off ponds, marshes and swamps, and cool wooded ravines with clear running streams, all form conspicuous habitats. The bluffs are more open than the lower ground, but even the bluffs are sometimes crowned with open woodlands of oak, ash, hickory, walnut, linden, and other deciduous tree species. Certain eastern woodland animal and bird species occur here, as, for example, the woodchuck, ruffed grouse, broad-winged hawk, and other smaller forms. To judge from archeological findings, as well as from the records of early explorers, elk and white-tail deer must formerly have been abundant. The soil is rich and varied, and water and fuel are more abundant than in any other part of the State. It is at present the most heavily populated portion of Nebraska, and undoubtedly the combination thus offered of open plains passing into wooded bluffs and bottom lands plus the heaviest precipitation in the State would have appealed to horticulturally minded Indian peoples as well.

In considering the natural factors affecting the aboriginal occupation of Nebraska the fact that the entire State was in the very center of the old buffalo range must be stressed. Speaking of the bison, Allen (1876, pp. 175, 176) says:

Over a large part of the former vast region they inhabited they were as numerous, as they now are [1876] in Western Kansas or Northern Texas, and ranged at different seasons over the whole. Particular portions of this area have ever formed their favorite places of resort, where they were sure to be found at almost any season of the year. There is, for instance, abundant historic evidence that over the plains of Kansas [sic], especially near the forks of the Platte, along the Republican, the Pawnee, the Canadian, and other tributaries of the Arkansas, they were as numerous when these parts were first visited by the early explorers as they have been ever since, and that subsequent travellers have always found them in immense numbers at all these points, the plains there literally swarming with them.

Such evidence not only justifies the general conception of Nebraska and Kansas as constituting the center of bison distribution, but also brings home the extreme recency and tragic thoroughness of the extermination of the buffalo in this portion of the plains. In Nebraska, about 1849, also occurred the permanent division of the buffalo into the northern and southern herds which were never united again. Allen (1876, pp. 144, 145) says:

The great overland route, as is well known, followed up the Kansas and Platte Rivers, and thence westward by the North Platte, crossing the Rocky Mountains by way of the South Pass. The buffaloes were soon all driven from the vicinity of this line of travel, thousands being annually slaughtered, a large proportion of them being killed wantonly. The increase of travel, and finally the construction of the Union Pacific Railroad and the consequent opening up of the country to settlement has effected a wider separation of the herds, the buffalo retiring every year further and further from their persecutors. None are now found for a long distance to the north of this road, and they approach it from the southward only along that portion situated between Fort Kearney and the Forks of the Platte.

Allen quotes Col. Richard I. Dodge to the effect that the Dakota tribes exterminated the bison in the High Plains region of Nebraska and adjoining States:

The great composite tribe of Sioux driven by encroaching civilization from their homes in Iowa, Wisconsin, and Minnesota, had crossed the Missouri and thrust themselves between the Pawnees on the east and the Crows on the north and west. A long-continued war between the tribes taught at least mutual respect, and an immense area, embracing the Black Hills and the vast plains watered by the Niobrara and White Rivers, became a debatable land, where they were comparatively unmolested, remaining there summer and winter in security. When the Pawnees were finally overthrown and forced on to a reservation, the Sioux poured into this country, just suited to their tastes, and, finding buffalo very plenteous and a ready sale for their robes, made such a furious onslaught upon the poor beasts that in a few years scarce a buffalo could be found in the extensive tract of country south of the Cheyenne and north and east of the North Platte River. This area, in which the buffalo had thus become practically extinct, joined on the southwest the Laramie Plains country, and there resulted a broad east-and-west belt from the Missouri to Montana which contained no buffalo.²⁷

Although one may justly doubt that the Dakota alone or even in large part effected the decimation of these herds, especially when one considers the terrific inroads made by professional hide hunters and meat hunters for the railroads, mines, army posts, etc., the quotation is of interest in regard to the nature of the late Dakota occupation of

²⁷ Dodge, R. I., Chicago Inter Ocean, August 5, 1875, quoted by Allen, 1876, pp. 163-164.

the region. The Dakota had been constantly harassing the Pawnee for many years before but the final blow came in 1876, when a war party of Teton and Oglala Dakota fell upon a Pawnee hunting party in southwestern Nebraska and drove them from the field with considerable loss. This was the last buffalo hunt of the Pawnee and very shortly after the broken and dispirited tribe removed to the Indian Territory in what is now Oklahoma. In any event the presence of large herds of buffalo in the grassland regions of Nebraska can be taken as an important factor in considering the natural resources available to the aboriginal inhabitants. Whether the presence of the buffalo was as important in Plains economy before the advent of the white man and his horse as it became afterward is a question to be answered by the archeological findings.

Before leaving the subject of geographic factors in relation to human occupation in Nebraska certain other general features must be considered. First of all, Nebraska has a typical inland climate with hot summers and mild dry winters but is subject to sudden and severe changes due to the cyclonic nature of the weather. The mean annual temperature varies from above 50° F. in the southeastern part of the State to less than 45° F. in the northwest. Nights in summer are generally cool, especially in the higher western portions. Rainfall occurs mainly in connection with thunder storms moving across the country with the cyclones, the mean annual rainfall decreasing from over 33 inches in the southeast to less than 15 inches in the west. Seven-tenths of the rainfall comes in the growing season from April to August and during the middle of this period the climate of the southeastern portion can almost be called humid. There is, however, great variability of rainfall, especially in the western counties. Wind velocity, as elsewhere in the plains region, is high and for the State as a whole averages about 10 miles per hour, being greater in the west than in the east. The snowfall is about one-twelfth of the total rainfall, coming in January and February for the most part, and as a rule lying on the ground only a short while. The snowfall is greatest in the northeastern counties. When these factors are considered in relation to the topographic areas already discussed a reasonably complete picture of the territory comprising the State of Nebraska can be formed.

On the map (fig. 2) the approximate territories held by Nebraska tribes in the early part of the nineteenth century have been indicated.²⁸

²⁸ It is impossible to delimit accurately tribal territories in Nebraska, owing primarily to their variations from time to time and also to the fact that there were always disputed border areas. The map, figure 2, is a compromise based on the following sources: The Omaha, Fletcher and La Flesche, 1911, pl. 21;

The four main geographic and biotic areas of the State are also indicated by varied hachuring. The superimposition thus obtained shows several very interesting correlations between tribal domains and natural areas. First of all, the Pawnee during this period held the heart of the State, including almost all the Loess Plain and half the Sand Hill areas. The Omaha and Oto (Dhegiha and Chiwere division representatives of the Siouan linguistic stock) occupy the entire Glacial Area (which coincides with the Interior Lowland of the Fenneman classification and the Missouri river-bluff region of Wolcott). The related Ponca border on this area to the north and west. The Dakota controlled the northern High Plains (and Bad Land) region with the western part of the Sand Hills, while the Arapaho and Cheyenne exerted a transient control over the southwestern High Plains in Nebraska. The Padouca or Comanche formerly occupied the heart of the Sand Hill region, but they had moved far to the south and west prior to 1800. After their departure the Sand Hills seem to have served as a buffer area between tribes instead of being exclusively occupied by any one of the latter. Certainly the Ponca and the Omaha extended their activities into the region but seem definitely to have claimed very little of it.

It is hard to believe that one of the richest portions of the State, i. e., the Glacial Area, was first occupied by Siouan tribes subsequent to 1796 as our fragmentary historic data suggest. No evidence of their having taken it from the Pawnee exists, yet had it been unoccupied prior to 1796 surely the latter tribes would have claimed at least portions of the Missouri River border. As will be indicated in the next section, a rather mysterious prehistoric culture that does not appear to have been Pawnee is found throughout the Glacial Area. Whether this older culture represents a prehistoric Siouan occupation or pertains to some unknown people who vanished prior to the advent of the white man must be established by archeological research. It is also of interest and undoubtedly significant that the two richest farming regions, namely the Glacial Area and the Loess Plains, were entirely occupied by sedentary and horticultural Siouan and Caddoan tribes respectively. The question arises whether the accidental occupation of such a potentially rich horticultural section led these tribes into such practices or whether their choice of territory in Nebraska was conditioned by their already possessing a culture based on agriculture.

Ponca and Oto (in 1832), Mooney, 1898, pl. 57; Arapaho and Cheyenne, Mooney, 1907, pl. 10; and the Pawnee, Wedel (no date). The northern boundary of the Pawnee range differs somewhat from that indicated by Wedel.

When the archeologists can demonstrate the prehistoric horizons from which each culture developed, the question may be answered.

Our brief study of natural areas and tribal territories in Nebraska also indicates a striking cultural adaptation on the part of all local tribes to their particular geographic areas. Thus, the nomadic, buffalo-hunting Dakota, Arapaho, and Cheyenne occupied the elevated and rather sterile High Plains where game was formerly abundant; the more advanced and horticultural Pawnee held the rich Loess Plain area which was also the heart of the buffalo range; and the sedentary Ponca, Omaha, and Oto were mainly along the Missouri River in an area well adapted to cultivation and immediately adjacent to the rich hunting grounds of the western plains. One of the major problems of our area is here outlined—was the pre-Caucasian mode of life in the area horticultural and sedentary, or nomadic and based primarily on hunting? In other words, Do the Dakota or the Pawnee most closely represent the norm of aboriginal culture in the central Plains prior to Caucasian interference? It is the purpose of the present paper to demonstrate, in so far as the available data permit, the prehistoric background from which these divergent culture types emerge. When these data have been considered, it may be possible to throw more light on this and similar problems of the region.

PREVIOUS ARCHEOLOGICAL WORK IN NEBRASKA

Ever since 1906 American anthropologists might well have reworded the ancient saying concerning Africa to read *semper aliquid novi ex Nebraska*. Unfortunately, however, the archeological surprises from this great central State have often turned out to be more startling than revolutionary. As a result, Nebraska has existed in the foreground of archeological consciousness despite the fact that her prehistory has been almost unknown. It is, for example, impossible to even find the name Nebraska in the index of Cyrus Thomas' (1894) voluminous report on the mounds of eastern North America, and the latest general book on the same subject has but two sentences touching on the State, and of these the last is of very doubtful authenticity.²⁰ Perhaps the fact that the scant archeological literature of the State has often been controversial rather than definitive fostered this state of affairs, for there is certainly no lack of historic and prehistoric aboriginal remains in the State. Yet, with the exception of a small area bordering the Missouri River reported on by Gilder and Sterns,

²⁰ Shetrone, 1930, p. 340, "A few scattering mounds have been noted in eastern Kansas, mainly along the Kansas River, and still fewer are reported from eastern Nebraska. The latter appear to be mostly low house mounds."

very little information on Nebraska archeology has crept into any of the more general treatises on New World prehistory. It seems worth while, therefore, to review briefly the general scope and status of archeology in Nebraska before presenting such new evidence as is available.²⁰

Rarely does the anthropologist in the Missouri or the Columbia River valleys turn in vain to the accounts of those great scientific explorers, Meriwether Lewis and William Clark. They saw much of the living Indians and more surprisingly many things that pertained to the past activities of the Indian people. What they saw they recorded briefly but accurately, for they had keen eyes and clear judgment. Thus, on July 12, 1804, we find the following entry in the original journal of William Clark (Lewis and Clark, 1904, p. 75):

Concluded to Delay here today with a view of takeing equal altitudes & making observations as well as refreshing our men who are much fatigued. after an early Breakfast I with five men in a Perogue assended the River *Nc-Ma-haw* about three [2] Miles to the Mouth of a Small creek on the Lower Side, here I got out of the Perogue, after going to Several Small Mounds in a level plain, I assended a hill on the Lower Side, on this hill Several Artificial Mounds were raised, from the top to the highest of those Mounds I had an extensive view of the Serounding Plains, which afforded one of the most pleasing prospect I ever beheld, under me a Butifull River of Clear Water of about 80 yards wide Meandering thro: a level and extensive meadow, as far as I could See, the prospect much enlivened the fiew Trees & Shrubs which is bordering the bank of the river, and the Creeks & runs falling into it, The bottom land is covered with Grass of about 4½ feet high, and appears as level as a smoth surface, the 2^d bottom [the upper land] is also covered with Grass and rich weeds & flours, interspersed with copses of the Osage Plumb, on the rising lands, Small groves of trees are Seen, with a numbers of Grapes and a Wild Cherry resembling the common Wild Cherry, only larger and grows on a small bush on the tops of those hills in every direction, I observed artificial Mounds (or as I may more justly term graves) which to me is a strong evidence [indication] of this country being once thickly Settled. (The Indians of the Missouris Still keep up the Custom of Buryring their dead on high ground) after a ramble of about two miles about I returned to the perogue and descended down the river, gath^d. Som grapes nearly ripe, on a Sandstone Bluff about ¼ of a Mile from its mouth on the Lower Side I observed some Indian Marks, went to the rocks which jucted over the water and marked my name & the day of the month & year.

This was at the mouth of main Nemaha River in what is now Richardson County, Nebr., just north of the Kansas line. Subsequent excavation in certain of these mounds has verified Clark's

²⁰ The following summary makes no pretense at absolute completeness. It is drawn from all readily available sources but does not attempt to include all newspaper accounts or very obscure local reports.

conclusion that they had been used for purposes of burial. (Zimmerman, 1918, p. 475.) They have never been systematically worked and reported on, however.

On July 27 Captain Clark writes (Lewis and Clark, 1904, pp. 91-92) :

I took one man R. Fields and walked on Shore with a view of examining Som Mounds on the L.S. of the river those Mounds I found to be of Different hight Shape & Size, Some Composed of sand some earth & Sand, the highest next to the river all of which covered about 200 acres of land, in a circular form, on the Side from the river a low bottom & small Pond. The Otteaus formerly lived here.

This was near the present southern boundary of the city of Omaha and was probably on a flat below the elevated series of bluffs which border the river here. Gilder at one time suggested that this Oto village was the same as the series of prehistoric house pits and mounds on the bluffs at Child's Point (1908, p. 73), but subsequently decided that the Oto village must have been on a lower flat since washed away by the Missouri River in the constant shifting of its channel (1907, pp. 64-65). This is in all probability correct and it is certain that Clark's description cannot be applied to the Child's Point sites. On July 28th, from the past mentioned camp, the journal continues (Lewis and Clark, 1904, p. 92) :

Passed at 1 ml. a Bluff on the S.S. the first high land above the Nodaway approaching the river on that Side, a Island and Creek 15 yds. wide on the S.S. above this Bluff, as this Creek has no name call it Indian Knob Creek [probably Indian Creek flowing into the Missouri at Council Bluffs—present author] our party on Shore Came to the river and informs us that they heard firing to the S.W. below³¹ this High and on the S.S. the Aiauway [Iowa] Indians formerly lived, below this old village about 5 miles passed Some Monds on the L.S. in a bend where the *Otteauze* [Oto] Indians formerly lived, this Situation I examined, found it well situated for Defence, about 2 or 300 acres of Land Covered with Mounds.

Clark also gives a good description of the hilltop grave of the famous (or infamous) Omaha chief, Blackbird (Lewis and Clark, 1904, p. 106) :

Cap^t. Lewis myself & 10 men assended the Hill on the L.S. (under which there was some fine Springs) to the top of a high point where the *Mahars King Black Bird* was burried 4 years ago. [Died of small pox] a mound of earth about 12 [feet—Biddle] Diameter at the base & 6 feet high is raised over him

³¹The rest of this paragraph follows the original manuscript which had been crossed out by another pen. The Biddle edition says that the Iowas "emigrated from this place to the river Des Moines," as does the Coues edition. Neither of the later editions mentions the old "Oto" site again.

turfed, and a pole 8 feet high in the Center on this pole we fixed a white flage bound with red Blue & white, this hill about 300 feet above the water forming a Bluff.

There are a few other references to Omaha burial customs and village sites in the original journals, but these do not directly concern us in the present report. When the latter have been definitely relocated and carefully excavated, so that the criteria for the historic sedentary Siouan occupation are known, a great step in Plains archeology will have been made.

A summary of all the accounts during the period of exploration which touch on the village sites of Nebraska tribes would have great value but cannot be included here.³² For present purposes we may only sum up such as have a definite archeological bearing on the problem in hand. An early record of this sort is made by Hayden in 1872, when he describes an ancient Pawnee village site near Beaver Creek just northwest of the present town of Genoa, Nebr.³³ He also mentions in passing, but without locating them, ancient village sites associated with pottery in the valleys of the Little Blue, Big Blue, Platte, and Loup Rivers. The finding of a "large coarse arrow or spearhead" in a railroad cut $2\frac{1}{2}$ miles southeast of Omaha, Nebr., is recorded by Samuel Aughey. The find as reported was remarkable, since 13 inches above the point and almost in line with it, likewise under 20 feet of loess, occurred the lumbar vertebrae of a fossil elephant.³⁴ The point was stemmed and about $3\frac{1}{4}$ inches in length. The record stands by itself without further confirmation, and later anthropologists and geologists generally have placed little credence in it. It is interesting, however, in connection with later finds to be discussed shortly.

The disputed aboriginal flint quarry sites near Nehawka in Cass County early excited much local interest and discussion. They were described in 1888 by Todd (1888, pp. 374-376), in some detail and with great clarity. He concluded, partly on the basis of his own observations and partly as a result of the disinterested labors of Isaac Pollard, that they were of human origin. A conclusion confirmed by Blackman³⁵ as well as by Winchell, Upham, and Brower (Blackman, 1903, pp. 314-317), who formed part of a committee that visited

³² See Wedel (no date) for a summary of such early records concerning the Pawnee tribes in Nebraska.

³³ Hayden, 1872, pp. 411-412. Quoted by Holmes, 1903, p. 199, with illustrations of the pottery. This was either the Burkett site or one nearby of similar protohistoric Pawnee affiliations.

³⁴ Hayden, 1876, p. 254. Compare Shimek, 1908, p. 244, and 1917, p. 97.

³⁵ 1907 b, pp. 103-110. Also 1903, p. 297, 1905, pp. 3-5, and 1907 a, p. 354.

the site in 1902. Since definite artifacts or indisputable human evidence have not been found in any of the quarry pits so far opened, the problem is not a simple one. Sterns (1915 a, I, pp. 126-135), on the basis of personal examination concluded that the assumed quarry pits were of natural rather than human origin, though these conclusions have not as yet been published. Unfortunately my own researches here were not directly concerned with the "quarry pits" themselves, and hence throw only an indirect light on the problem. We will return to this subject briefly in a later section.

In 1892 a brief article was published stating that the mounds along the west side of the Missouri were the remains of earth lodges rather than artificial burial mounds. (Jones, 1892, pp. 111-112.) Since the whole matter of Nebraska "mounds" is a troublesome problem, it will be discussed in a later section. There seems little on record for this decade concerning Nebraska archeology. Certain second-hand observations given by Grinnell (1893, pp. 255-256) on the subject of pottery making by the Pawnee have value, especially since little else is extant on the subject. Likewise, the general study of eastern ceramics made by Holmes (1903, pp. 58-59, 145, 199, and pl. CLXXVII) has some direct references to Nebraska problems. He figures some of the sherds collected on Beaver Creek by Hayden and generally classifies Nebraska as being in the northern and simpler area of eastern ceramics. The Beaver Creek sherds figured and the projected shapes derived therefrom are excellent and present a good sample of protohistoric Pawnee pottery in its best period.

On October 21, 1906, the Omaha World-Herald announced the finding of human remains occurring in undisturbed loess formation and presumably of great antiquity. In excavating an apparently artificial mound on Long's Hill about 10 miles north of Omaha, Robert F. Gilder had run into a large number of disarticulated human bones both above and below an area of what appeared to be burned clay which occurred at a depth of about 4 feet. The remains from the upper strata appeared to him and to others who examined them to be of a relatively modern Indian type but the lower skulls had certain apparently primitive characteristics. (Gilder, 1907 a, pp. 35-39; 1907 b, pp. 378-381.) Interested in the report, Henry Fairfield Osborn made a trip to Omaha, examined the material, and later published a rather cautious article (1907, pp. 371-375) stating that although the remains were more recent than Neanderthal man and might even be more recent than early Neolithic man in Europe, they were of a very primitive human type. The skeletal material was transferred to the University of Nebraska, where it was studied by E. H. Barbour and H. B.

Ward. On the basis of their study of the bones, combined with the geologic examination of the site, they concluded that the bones of the lower layer antedated the formation of the loess hill, whereas the bones of the upper layer were younger. (Barbour and Ward, 1906, pp. 319-327.) Later, after further study and excavations carried out at the site, Barbour stated (1907 a, p. 331 et seq.) that "he stands ready to give notice of the occurrence of human remains in the loess, and unhesitatingly and unconditionally announces his belief in the discovery of Nebraska loess man." He adds that there is no discoverable relationship between the upper and lower human remains, that the lower skulls are of the Neanderthal type especially resembling the man of Spy, and that the suspicion of Pleistocene man in America is therefore verified.³⁶

Blackman, who also examined the site and the material, in general accepts Barbour's conclusions but adds that there exists a possibility of the intrusion of the lower bones into their deeper situation through the activity of gophers. He also adds that the present-day formation of the loess by wind action is the greatest argument against extreme antiquity. (Blackman, 1907 c, pp. 76-79.)

In January 1907 the site was visited by A. Hrdlička after he had studied the skeletal material at Lincoln. Weather conditions were such that little actual excavation seems to have been accomplished on this visit. In his report, brought out soon after, Hrdlička (1907, pp. 66-98) sums up the bulk of the evidence and presents his own conclusions. In relation to the general problem of artificial mounds in Nebraska it is of interest that Hrdlička, like the other authorities quoted in this regard, accepts the artificial nature of the mound on top of Long's Hill, though he specifically states that no lines of soil demarcation could be distinguished.³⁷ Briefly stated, his main conclusions are twofold; first, that the remarkably low foreheads and pronounced supraorbital ridges of certain of the skulls seem to him to be individual variations representing either exaggerations of definite sexual characteristics, examples of degeneration, or reversions. He points out (1907, pp. 92, 96) that these characteristics as well as the size and thickness of the crania of the "loess man" type can be found in equal

³⁶ Barbour, 1907 a. Also see same author, 1907 b, pp. 110-112; 1907 c, pp. 40-46. The last citation states that there are three races represented at the Long's Hill site, the oldest being loess man synchronous with the glaciation, then the mound-builder type, and last the (intrusive) modern skull.

³⁷ Hrdlička, 1907, p. 75. Shimek, cited below, is an exception to this general statement, and Gilder in a later paper (1908, p. 68) stated that the burial mound can be partially traced from inside the excavation.

and even more exaggerated form among modern and ancient Indian groups, being especially marked in mound-building peoples of the upper Missouri and Mississippi. Secondly, he argues (1907, pp. 87-91) that the bones are not fossilized, that certain of the bones show evidence of having been gnawed by rodents and in some cases have been cut with sharp implements, the latter almost always restricted to the skull and long bones and occurring on both the assumed most ancient and most modern remains; and thirdly that rodents have obviously been active in the mound and through the caving in of their burrows the fragmentary bones could have easily reached the deeper levels at which they were found. His results are summed up as follows (1907, p. 98):

The mind searches in vain for solid ground on which to base an estimate of more than moderate antiquity for the Gilder Mound specimens. The evidence as a whole only strengthens the above conclusion that the existence on this continent of a man of distinctly primitive type and of exceptional geological antiquity has not as yet been proved.

Gilder (1911 a, pp. 157-169) has since offered certain objections to some of Hrdlička's statements and conclusions, the most important of which seem to be that the double layer of human remains found at Long's Hill is not usual in Nebraska mounds but highly exceptional, that the assumed "knife marks" are all of animal origin, and that none of the low-browed Indian skulls figured by Hrdlička shows the heavy supraorbital ridges meeting between the eyes as is the case in the "loess" type. Poynter, in a brief study of Nebraska crania (1915, pp. 509-524), indicates that the Long's Hill group are of a "low order racially" and form a distinct type, and Hooton, in studying the skeletal material collected by Sterns, groups the "loess man" with certain isolated finds from near Plattsmouth as a distinctive type (Sterns, 1915 a, I, pp. 147-162). Until a thorough study of Nebraska crania from the historic sites occupied by known tribes, as well as prehistoric remains from carefully determined culture strata, has been made, no clear-cut conclusions as to the sequence of types are possible. That the Long's Hill type may prove to be distinctive seems highly probable. That it is pre-Indian or of Pleistocene age, however, seems highly improbable.³⁸

What appears to have been the most systematic and careful piece of work carried on at the Long's Hill site, at least so far as one may judge from the various published accounts, was that of Shimek.³⁹

³⁸ See Boule, 1923, pp. 407-408.

³⁹ Shimek, 1908, pp. 243-254. See pl. 15, fig. 1. It is remarkable that with this single exception not one good photographic or detailed diagrammatic presentation of the evidence in situ appears in the literature of this dispute. The Barbour

According to this authority the boundaries of the disturbed area forming the mound can be traced in lateral section beyond the edges of the previously excavated area. Unfortunately, this evidence is not indicated by any diagram. He points out the fact that the second layer (3-7½ feet) reported as undisturbed by Barbour contains modern shell forms, is of loose texture, and that buried or intrusive soil can be traced between the depths of 7½ and 8½ feet. In spite of careful searching he found no bones below this layer, though the presence of root channels and gopher burrows might make their intrusion possible. He is unable to confirm Barbour's conclusion that certain of the deeper human bones were water worn and concludes that an ordinary burial mound of no geologic antiquity is represented here. Last of all he scouts the idea that the loess itself is glacial. Since this brings one to the complex problem concerning the aeolian or glacio-fluviate theories of loess deposition, a halt is indicated. (Also see Shimek, 1917, pp. 93-98.) Sufficient for present purposes is the fact that Shimek agrees with Hrdlička in denying any geologic antiquity to the human remains in question.

Returning to a more general consideration of the progress of archeological research in Nebraska, the long-continued work of E. E. Blackman must be considered. Appointed Archeologist of the Nebraska State Historical Society in 1901, Mr. Blackman, with the exception of certain periods when he was employed elsewhere, has continued his labors in this field up to the present time. His work in regard to the Nehawka flint quarries has already been referred to. In addition, his various annual reports⁴⁰ contain references to a great number of historic and prehistoric aboriginal sites both in Nebraska and just beyond the State boundaries. In his first report⁴¹ may be found a good brief account of the Indian tribes known, or believed, to have occupied Nebraska within the historic period. His early classifications of Nebraska cultures and ceramic types (1903, pp. 310-314; 1905, p. 5; 1906, pp. 394-395) are perhaps not so fortunate, though these were made at a time when lack of data made adequate generalizations impossible. Particularly valuable are his brief references to

ground plan (1907 a, fig. 5, p. 335) is complex but not illuminating, whereas the Gilder plans (1908, figs. 31, 32, pp. 63-64) are unconvincingly schematic. Hrdlička (1907) gives no diagrams or photographs of the site.

⁴⁰ Blackman, 1903, 1905, 1906, 1907, 1928, 1930.

⁴¹ 1903, pp. 317-325. With this should be mentioned an historical summary of somewhat the same type by Father M. A. Shine, 1914, pp. 1-23. There are several tribes mentioned by Blackman as having occupied Nebraska for which no historic records exist.

such historic sites as the Oto village near Yutan (1903, p. 296; 1907 a, p. 355), the Omaha village on the forks of the Papillion (1906, p. 391), the historic Pawnee villages at Linwood, Horse Creek, Clarks, Genoa, and the McClaine site near Fremont.⁴² He explored the remarkable protohistoric Pawnee villages at the Schuyler or Gray site and at the Burkett site (1905, p. 5; 1903, p. 297). Later he carried on excavations at the Burkett site, deciding that it was a Skidi Pawnee village dating from around 1341 A. D. (1907 a, pp. 339-344; 1924, pp. 1-8). Blackman also examined the Republican Pawnee village near Republic, Kans., reputed to be the one visited by Zebulon Pike, and pointed out that the local topography was not in agreement with the maps and descriptions of Pike's exploring party.⁴³ Mr. Blackman is still interested in archeological research in Nebraska and has much unpublished data.

Almost contemporaneous with that of Blackman has been the work of Dr. Robert F. Gilder, of Omaha, Nebr. Originally a newspaper man, he became interested in archeology in 1903 and since that time has carried on such research in all available time. In addition, it should be added that Dr. Gilder is also an artist of unusual distinction. Although connected with the University of Nebraska for some time and having received an honorary degree from that institution, much of Gilder's archeological work has been independently carried on. Although he has done some reconnaissance work in Arizona and Wyoming, the bulk of his excavation work has been accomplished in the Omaha district of Nebraska and to a lesser extent across the Missouri in Iowa.

The modern city of Omaha is located in one of the richest archeological sections of Nebraska, especially as regards prehistoric earth lodges of a rather remarkable type. The culture of these prehistoric lodges has been described by Gilder in a number of papers.⁴⁴ These articles are especially valuable in setting forth the characteristics of this quite unique culture, the artifacts of which are well illustrated in Gilder's papers of 1907, 1909, 1911, 1913, and 1926. Owing to incomplete excavation, the statements and diagrams made by Gilder in regard to the circular shape of all these prehistoric lodges appear

⁴² 1907 a, p. 329; 1903, p. 297; 1907, pp. 355-358; 1903, p. 296. Wedel, (no date), gives further information regarding these sites.

⁴³ 1907 a, p. 349. Also see Pike-Pawnee Village, 1927 a, pp. 182-192, and Wedel (no date).

⁴⁴ Gilder, 1907, pp. 702-719; 1908, pp. 173-174; 1909, pp. 56-84; 1911, pp. 249-259; 1913, pp. 107-115; 1926, pp. 1-32.

to be in error.⁴⁵ The typical earth lodges of this culture have since been found to be characteristically subrectangular or square, although a very few round houses of this culture have been opened. (Sterns, 1915 a, II, p. 204.) In 1926 Gilder published a little brochure entitled "The Nebraska Culture Man", in which he briefly summed up and illustrated the characteristics of this prehistoric rectangular earth lodge culture of the Missouri River bluffs in eastern Nebraska. The term "Nebraska culture" thus given seems a convenient name for the inclusion of all lodges of this sort marked by the same distinctive pottery and artifact complex, hence it has been adopted in the present work. The characteristics of the Nebraska culture as revealed by the work of Gilder, Sterns, and the University of Nebraska Archeological Survey in 1930 and 1931, will be summed up and discussed in a later section.

Dr. Gilder has not confined his activities entirely to the earth lodges but has also excavated a number of burial mounds and other sites in the same region.⁴⁶ The much-discussed excavations at Long's Hill have already been mentioned. The large collections made by Gilder are considerably scattered. Much material is in storage at the State Museum at Lincoln, an excellent collection obtained between 1907 and 1912 is on exhibition at the Omaha Public Library,⁴⁷ and a third collection is in Gilder's own possession. The credit for having discovered and brought to scientific attention the unique Nebraska culture must go entirely to Gilder. Others have enlarged upon and in part corrected his work, but he has been the pioneer in a field in which he is still an active figure.

During the years 1912-1914 the region of southeastern Nebraska was worked both extensively and intensively by Dr. Frederick H. Sterns for the Peabody Museum of American Archaeology and Ethnology. Sterns's work included parts of Thurston, Burt, Washington, Douglas, Sarpy, Otoe, Nemaha, Richardson, and Lancaster Counties in Nebraska, Brown and Doniphan Counties in Kansas, and Pottawattamie County in Iowa. In Nebraska he opened 27 earth lodges of the Nebraska culture, discovered the stratification at the important Walker-Gilmore site in Cass County, and examined a large number of other sites in the general region above outlined. His published reports (1914, pp. 135-137; 1915, pp. 121-127) have been brief but

⁴⁵ Gilder, 1907 and 1909. See Sterns, 1914, p. 135, and Gilder, 1913, p. 107, and 1926, p. 5, for correction in this regard.

⁴⁶ Gilder, 1907, p. 710; 1908; 1908 a, p. 173; 1909, pp. 61-76; 1913; 1914.

⁴⁷ This collection fortunately has been well catalogued. (See Gilder, R. F. (no date), in bibliography.)

highly significant. The bulk of his data, however, has unfortunately never been published. These data are to be found in two large volumes on file in the library of Harvard University in the form of a doctor's dissertation entitled "The Archaeology of Eastern Nebraska, with Special Reference to the Culture of the Rectangular Earth Lodges." This well-illustrated work contains a vast amount of detailed and exceedingly valuable data, especially on those prehistoric Nebraska cultures designated in the present volume respectively as the Sterns Creek culture and the Nebraska culture. I have elsewhere acknowledged my debt to Dr. Sterns for permission to incorporate some of his data in the present report. This material will be discussed at some length in later sections. From the strictly scientific standpoint Sterns's various reports stand preeminent in the field of Nebraska archeology.

Between 1914 and 1929 there appears to have been no very extensive or coordinated work carried on in the State. Nevertheless, various individuals already mentioned were active, and some outside reports appeared. In a paper published by Zimmerman (1918, pp. 471-487) are some valuable data on house sites and mounds in extreme southeastern Nebraska. Unfortunately, Zimmerman has a tendency to so confuse his concrete data with various theoretical considerations that the two are often hopelessly intermingled. In 1922 a brief report of Gerard Fowke's archeological investigations along the Missouri River in northern Kansas and southern Nebraska appeared (1922, part III, pp. 151-160). The portion of this report dealing with northeastern Kansas and southeastern Nebraska covers much the same ground as that of Zimmerman just cited. Both refer to an early historic Pawnee village near the mouth of the Nemaha River (Fowke, 1922, pp. 152-153; Zimmerman, 1918, p. 473) and Fowke states that the Pawnee lived here until 1837, when they were wiped out by the Iowa and Oto, and that two Iowa women living in 1914 tell of the bodies lying around the site. Neither Wedel nor myself have been able to secure any historical references to this village nor to the historic Pawnee ever having lived in this immediate vicinity. Sterns examined the site and described the pottery, concluding that it was "almost historic" but assigning it to no particular tribe.⁴⁸ From Sterns's description the ceramic remains here are all shell-tempered and bear little or no resemblance to any known Pawnee pottery. Unless definite historical evidence can be produced connecting this Nemaha site with the Pawnee, such an identification is in all probability erroneous and

⁴⁸ 1915, a, II, pp. 171-176, 264. Blackman, 1928, p. 511, also mentions this site and says that the pottery tempering suggests Osage ware, whereas forms of vessels are similar to Ohio types.

should be corrected. Fowke also reviews some of Gilder's work and discusses the Long's Hill find at some length. He appears to lean heavily on the fact that "save for some markings on pottery" all "relics" from the mounds and house pits in the vicinity are the same as those from the Lewis and Clark villages. Since I know of not a single village on this part of the Missouri mentioned as occupied in the time of Lewis and Clark which has been positively identified or scientifically excavated since, it is hard to tell where Fowke gets his information. He concludes this section of his report with the following remark: "Any estimate of age must be only a guess at best, but it is a safe guess that no earth work, mound, lodge site or human bone along this part of the Missouri River has been here as long as 10 centuries."

Bushnell (1922 and 1927) published two reports on the villages and burials of Algonkian, Siouan, and Caddoan tribes west of the Mississippi. Both accounts contain much valuable historical and descriptive material concerning such Nebraska tribes as the Pawnee, Omaha, Oto, and others in the historic period. In the same year appeared a report bearing on the disputed question of the exact location of the Republican Pawnee village visited by Zebulon Pike in 1805. (See Pike, Pawnee Village, 1927.) This publication was largely instigated on the Nebraska side by the discoveries and excavations of A. T. Hill, of Hastings, Nebr. An enthusiastic amateur archeologist, particularly interested in all that concerns the Pawnee, Mr. Hill has been an ardent field worker and student of Nebraska archeology for many years. His very valuable researches will be referred to in more detail in later sections.

We must now turn from strictly archeological considerations to a paleontologic discovery and discussion which for some time made western Nebraska a focal point in the eyes of all students interested in the major problems of human evolution and prehistory. On February 25, 1922, Henry Fairfield Osborn received from Harold J. Cook a worn molar tooth collected by the latter in the Pliocene deposits of the Snake Creek beds of western Nebraska. Shortly afterward, following consultation and discussion with W. D. Matthew, W. K. Gregory, and M. Hellman, Osborn published a brief paper describing the molar as the type of a new genus and species, *Hesperopithecus haroldcookii*, "an anthropoid of the Western World discovered by Mr. Harold Cook."⁴⁹ Since this was the first seemingly credible trace of an anthropoid primate so far reported from the Western

⁴⁹ Osborn, 1922, pp. 1-5; also, same author, 1922 a, pp. 281-283.

Hemisphere the announcement created a considerable stir in paleontologic and anthropological circles. Certain scientists inclined to accept the identification, but others, particularly Smith Woodward in England, suspected that the find had received an inappropriate name and that instead of representing the primate stem it should be compared with the last lower molar in primitive bears, notably *Hyaenarctos*.⁵⁰ To the layman it may seem incomprehensible that such a wide divergence of opinion could prevail among acknowledged leaders of paleontologic science, yet it must be remembered that man and the anthropoid apes as well as the pig and the bears are all omnivorous animals of widely variable diet and that their generalized dentition reflects the catholic nature of their tastes. Let the scoffer compare certain of the molar teeth of the domestic pig and man, and the difficulty will become apparent. When much-worn teeth of long extinct forms are thus compared, the problem is far more difficult. The matter, however, of a seemingly premature identification on somewhat slender evidence is not so easily explained.

In 1923 W. K. Gregory and M. Hellman published two brief papers containing notes on the tooth in question.⁵¹ In the first paper Matthew determined the age of the find as early Pliocene, equivalent in a broad way to Lower Pliocene (Hipparion fauna) in Europe. The authors state that the tooth is very different from those of *Hyaenarctos* and conclude that Osborn was probably correct in assigning it to a hitherto unknown form of the higher primates. The second paper is mainly taken up with a detailed argument as to the probable place of the tooth in the carnivore, anthropoid, or human series, Gerrit S. Miller, Jr. propounding the questions to be answered. The authors concluded that while the exact generic diagnosis of *Hesperopithecus* must await further discoveries they return with more confidence to their conclusions that it is probably a second upper molar of a hitherto unknown anthropoid ape resembling the gorilla and chimpanzee rather than the orang. Meanwhile further excavations in the Snake Creek beds were being carried on by A. Thomson, who was sent out by H. F. Osborn. For a brief period the controversy slumbered, awaiting the discovery of further evidence of a less debatable nature.

New fuel of a decidedly sensational nature was added to the discussion by Osborn in a report to the American Philosophical Society in 1927, in which, according to the article in *Science*, May 6, 1927,⁵² over

⁵⁰ Woodward, 1922, p. 750, and Boule, 1922, pp. 526-527. Compare Elliot Smith, 1924, V, and pp. 6-7, and Wilder, 1926, p. 156.

⁵¹ Gregory and Hellman, 1923 a, pp. 1-16, and 1923 b, pp. 509-532.

⁵² Vol. 65, no. 1688, *Science-Supplement*, p. X, 1927. Slightly corrected or amended, same vol., no. 1690, *Science-Supplement*, p. XIV, 1927.

300 implements of apparent human origin from the Pliocene beds in western Nebraska were described. According to this account the implements were of 40 different types, of which certain forms found counterparts in known artifacts from other archeological sites in North America. Since the materials employed in the former were the bones of extinct species of animals, and the artifacts came from the same general beds as the "*Hesperopithecus*" tooth, the presumption that the two finds were associated seemed logical. Such a presumption involved not only the occurrence of the hitherto unknown American anthropoid in the Pliocene of Nebraska but also the fact that he was already a tool-using animal with a well-developed material culture. When it is realized that the oldest human fossils yet discovered in the Old World are regarded as either early Pleistocene or very late Pliocene in geologic age and that no traces of a complex material culture have been found associated with them, the extremely radical implications of the above report become apparent. These implications were partially confirmed in an article published shortly thereafter by Osborn,⁵³ in which both *Hesperopithecus* and the fossil bone implements were entered on a chart showing the development of man through the Pliocene, Pleistocene, and Recent periods. Both were entered in the Middle Pliocene portion of the chart as the "most ancient evidence of man," but surmounted by a question mark.

This question mark was soon fated to grow to such proportions that it has completely overshadowed the above tentative conclusions. In Science for December 16, 1927, Gregory published an article entitled "*Hesperopithecus* Apparently Not an Ape nor a Man" (1927, pp. 579-581), in which he reviewed the earlier facts of the case and stated, on the basis of the more adequate material obtained from the Snake Creek beds by Thomson, his doubt regarding the correctness of his former identification of the original tooth as a primate. Rather it would appear that the tooth bore a more specific resemblance to many similarly worn-down premolar teeth of a species of *Prosthennops*, an extinct genus related to the modern peccaries. While there are certain details in which the "*Hesperopithecus*" tooth differs from those of *Prosthennops* in general it agrees with almost every conspicuous characteristic in that type. Many of the *Prosthennops* teeth had been found which resembled the "*Hesperopithecus*" specimen except that their crowns were less worn. He concludes: "Thus it seems to me far more probable that we were formerly deceived by the resemblance of the much worn type to the equally worn chimpanzee molars than that

⁵³ Osborn, 1927, fig. 1, p. 482. See also Vosy-Bourbon, 1929, p. 408, for a later foreign notice.

the type is a really unique token of the presence of anthropoids in North America."

The authenticity of the middle Pliocene bone "artifacts" of Nebraska was likewise soon strongly attacked by Nelson in an article entitled "Pseudo-Artifacts from the Pliocene of Nebraska."⁶⁴ Calling attention to Gregory's article setting forth his matured views, Nelson pointed out the necessity of an extremely careful investigation concerning the assumed artificial nature of the bone implements, especially since they stood alone without human remains, hearths, or stone implements for their manufacture. Of the former he had minutely examined nearly 3,000 specimens. He points out that primitive artifacts fall into two main classes, sharp edged or sharp pointed, and that ornaments are usually tubular or flat. Moreover, they have a recognized shape or design and usually show evidences of wear such as polish or abrasions and perforations. If the Nebraska Pliocene specimens were cut from bone prior to their fossilization, as is assumed, they too should show shape, wear, polish, cutting marks, abrasions, and perforations. On this basis Nelson finds no evidence either of their intentional design or of artificial workmanship. A few suggest beads and awls of an improvised, unfinished type. They do not correspond to definite artifact types in later American archeological horizons but rather to a few accidental fragments from the latter which have served temporary purposes. The grooves on some of the fossil bone fragments are at present inexplicable, but they are irregular and taken by themselves are meaningless. Two or possibly three fragments carry decidedly suggestive markings and are of a type which, if found by an archeologist in a refuse heap, might be preserved as showing purposeless and accidental human activity. No one can positively say that they are or are not the result of human activity, though they may merely be tooth marks. Likewise such splitting of bone as occurred prior to its fossilization might equally be the result of crushing by carnivores or by man between two stones. The more or less uniformly worn or polished condition of some of the artifacts is difficult to explain but does not appear to be the work of man. Nelson sums up his study as follows: "The inevitable conclusion is, therefore, in my judgment, that the presence of artifacts in the Snake Creek deposits is not established and can not be established by the collections examined to date."

Since 1927 both "*Hesperopithecus*" and the Pliocene "artifacts" have faded into the background. Perhaps future paleontological discoveries may revive them or bring a new "ape of the western world"

⁶⁴ Nelson, 1928, pp. 316-317. Also see Boule, 1928, pp. 443-444, for a somewhat ironic supplement.

back upon the stage once more, but for the present we must still look to the Old World for our prehuman predecessors.

Our account of archeological research in Nebraska is almost up-to-date. In 1929 the present author, while professor of anthropology at the University of Nebraska, organized a State archeological survey for that institution. The main results of this survey during the period from September 1929, to September 1931, are included in W. R. Wedel's report, "An Introduction to Pawnee Archeology,"⁵⁵ in a preliminary report by the writer (1933b), and in the present work.

The work of the University of Nebraska Archeological Survey since September 1931 has been under the direction of Dr. Earl H. Bell. In cooperation with Mr. Hill and other agencies interested in these problems, Dr. Bell is carrying on Nebraska field work.

HISTORIC AND PROTOHISTORIC PAWNEE CULTURE AS REVEALED BY ARCHEOLOGY

The study of historic Pawnee archeology was basic in the work of the University of Nebraska Archeological Survey from 1929 to 1931. Once the archeological criteria of this important Nebraska culture had been determined, it was then possible to begin the advance from the known and historic into the unknown and prehistoric. Much remains to be done in the field of historic Pawnee archeology, but its outlines are already clear enough to serve as a guide into the more murky depths of the prehistoric cultures of the State. When the archeological criteria for the sedentary Siouan occupation of Nebraska in early historic times are equally clear, another great advance will have been made. So far, however, attention has been concentrated on the historic Pawnee and on various prehistoric cultures, and almost nothing is known of the archeology of such Siouan tribes as the Omaha, Ponca, and Oto. The excavation of historic villages of these peoples is the next logical step toward an understanding of Nebraska culture problems.

Fortunately, the matter of historic Pawnee archeology has been dealt with at some length by others and need only be summed up in the present paper. Bushnell has gathered together various nineteenth century descriptions of Nebraska Pawnee villages.⁵⁶ These include the accounts of Pike, Long, Dunbar, Fremont, Murray, De Smet, and Grinnell, which, with the excellent photographs of W. H. Jackson showing Loup River Pawnee villages, furnish a good picture of the

⁵⁵ Awaiting publication by the Bureau of American Ethnology.

⁵⁶ 1922, pp. 155-167; also see Bushnell, 1927, pp. 79-82, for historic data on Pawnee burial customs.

externals of Pawnee life in this period. Museum ethnological collections present an equally vivid picture of the costumes, habitations, weapons, and utensils of the Pawnee in late historic times. But of the nonperishable artifacts characteristic of the Pawnee tribes in the early contact period very little has been available. Pottery, so important in any archeological study, is not represented in any of the Pawnee ethnological collections of our large museums, and the same can be said in regard to the majority of native-type stone or bone artifacts. Such things were rather quickly replaced by more efficient European kettles and tools, and by the time the ethnologist appeared on the scene they were long out of use. Hence if we want to know the concrete details of Pawnee life we must go to the early contact villages and get them from under the ground.

Before the present Nebraska Archeological Survey was organized, this work had already been well begun by A. T. Hill, of Hastings, Nebr. Mr. Hill had purchased and conducted excavations in the Zebulon Pike-Pawnee village just southeast of Red Cloud, Nebr.,⁵⁷ and his collections from this site were both extensive and accompanied by scientific data. In addition, he had studied the problem of locating the Pawnee sites referred to in early historical accounts, had visited all those that could be located, and had made sample collections from them. These invaluable data, the product of tedious research and excavation, he put freely at the disposal of myself and my assistants. In the late summer of 1930 the Survey party worked for 2 weeks at the Hill site near Red Cloud, and subsequently my research assistant, Waldo Rudolph Wedel, spent several weeks at Hastings studying the Hill collections. This was supplemented by many trips to all the historic Pawnee sites with Mr. Hill and by further excavations in such sites made by the Survey in 1931. Mr. Wedel has written up this phase of the Survey work in his paper, "An Introduction to Pawnee Archeology," hence I need only sketch in the outlines of historic Pawnee archeology therein presented. Our indebtedness to Mr. Hill is further emphasized by the fact that both in 1930 and 1931 he also gave generous support to Mr. Wedel's investigations.

In all, 10 historic Pawnee villages have been located to date.⁵⁸ Of these only two have been extensively investigated. These, the Hill site near Red Cloud in Webster County and the Linwood site near Linwood, Butler County, date from the period around 1800. While various other sites of both earlier and later dates have been more super-

⁵⁷ See the Nebraska History Magazine, vol. 10, no. 3, 1927; and Wedel, no date.

⁵⁸ See Wedel's paper for their exact location, documentation, and archeological details. For general location see fig. 1, sites 1-10, present paper.

ficially investigated, we will confine the immediate discussion to the Pawnee culture of about 1800, as revealed by our own excavations and Mr. Hill's work in these two sites. It may be added that the Hill site was occupied by members of the Kitkehahki or Republican Pawnee tribe while the Linwood site was occupied by the Chani or Grand Pawnee tribe. So far no distinction has been observed in archeological remains pertaining to the different Pawnee tribes. Although more detailed investigation may reveal new criteria in this regard, our own investigations indicate very close cultural uniformity for all these groups in the historic period.

In briefest outline the salient characteristics of Pawnee culture at the close of the eighteenth and the beginning of the nineteenth centuries, as revealed by archeology, are as follows. The five earth lodges opened at these two sites had been very slightly excavated below ground level, 20 inches being the deepest, and all of them were perfectly round, ranging from 20 to 45 feet in diameter. The central posts ranged in number from four (one house) to eight (two houses had six center posts, two had eight). The outer circle of posts ranged in number from 13 to 18, with an average of 12. Four houses had only one central fireplace, and one had two fireplaces. This second fireplace was immediately opposite the doorway, where the shrine is often located. One earth altar or shrine in this location was found. Entrance passageways about 12 feet long and 4 to 7 feet broad lead from the south or east side of the houses. There appeared to be no exact orientation in this regard. Three houses had no interior or exterior cache or storage pits, one house had four interior caches, and six were located outside the walls. The fifth house had one interior cache located between the fireplace and shrine and in line with the entrance passage. Such storage pits, therefore, occur both inside and outside the houses. They are usually cylindrical, being slightly wider at the bottom than at the top, with a flat floor. They range from 3 to 11 feet in depth, 4 to 5 feet being usual, and are often lined with decayed bark or white sand. Ashy soil containing much debris fills the majority of these pits, artifacts are rather rare, and the pits appear to have served mainly for storing corn.

At the present time earthworks in connection with the sites are rare, owing mainly to the many years of plowing to which the majority of the villages have been subjected. Sections of the old sod walls are preserved solely at the Horse Creek site in Nance County. There is no concrete evidence at present that palisades were in use. An interesting bit of evidence uncovered at the Hill site was a rectangular hard-

packed area surrounded by post molds, evidently a horse corral. Pawnee burials of this period are single inhumations, usually flexed, grouped on high hills near the villages. Gifts of various sorts occur with the bodies and they are often wrapped in reed matting. Caucasian artifacts, such as metal containers, reworked iron hoes, bridle bits, gun barrels, rifle balls, knife blades, scrap metal, and a little glass occur in house sites, cache pits, and burials in association with pottery and aboriginal artifacts. Horse remains are very common in cache pits and refuse deposits, along with bison, elk, deer, bird, and numerous animal bones. In fact horse and bison bones appear to constitute the bulk of the animal remains. Vegetal remains, charred corn predominating, are fairly numerous in cache pits and houses, and occasionally in graves. All these matters are discussed in detail by Wedel and need only be mentioned here.

Pawnee pottery of this period is very characteristic and fairly abundant, though complete pots are rare. Enough of the latter have been recovered, however, to fill in details regarding size and shape. All the pottery appears to have been hand molded, perhaps with a paddle and anvil stone. Two main wares have been distinguished. The most abundant of these (pl. 1, fig. 1, *a, b, c, d, f, i, k, l*) has a smooth paste with fine grit temper, often containing considerable mica. It is light buff ranging to gray in color, with a rough, irregular surface rubbed fairly smooth in some cases but rarely polished. Cord marks are noted occasionally on the body but are usually almost obliterated by subsequent rubbing. They do not occur on the necks of vessels. The pots are characteristically small to medium in size, globular in shape, with a more or less constricted neck. Especially characteristic is a collarlike rim from 1 to 3 inches in width (pl. 1, fig. 1, *a, b, c, d, l*) decorated with incised lines. In many cases tabs extend down from this collar and often these tabs are extended to the neck, forming a series of loop handles (pl. 1, fig. 1, *b, c*). The rim itself is often decorated by a series of straight or diagonal notches (pl. 1, fig. 1, *b, c*). The collar designs are especially characteristic and limited to four main types, an incised line forming a series of triangles filled in by hachuring (pl. 1, fig. 1, *a, d, f*) being most common, series of chevrons, herringbone, and simple diagonal lines (pl. 1, fig. 1, *b, c*) also being employed. The pieces illustrated (pl. 1, fig. 1) are all from the Hill site and show the lack of finish characteristic of decoration in this period. Lines are irregular and the work is careless in the extreme. The fixed tradition of form and decoration combined with a fundamentally advanced pottery technique are in marked contrast to the lack of interest displayed in finish and decoration. Quite obviously the pottery makers of

this period had lost interest in their work. It was a dying industry, formalized and decadent.

The second and less abundant type of Pawnee pottery also occurs in all sites of this period. Ware of this type is hard and flaky but similar to the last in its poor finish. The paste appears to contain much iron and as the result of firing ranges in color from a light yellowish brown to a bright orange red. Pottery of this type is much thicker than that previously discussed, although there is considerable variation in this regard even in the same piece. Uneven drying or firing has apparently caused many of these pieces to crack along the midline of the walls. Its characteristic completed form is a round, open-mouthed bowl without handles or incised decoration (pl. 1, fig. 1, *h*). The specimen figured is unusual in having a separate lid with a loop handle (pl. 1, fig. 1, *e*). Both pieces were found close together in the same house at the Hill site and have been carefully restored. Since separate lids are unknown in any Nebraska prehistoric culture, it may be that this is a Caucasian introduction. Two other plain-rim sherds of this type are figured (pl. 1, fig. 1, *g*, *j*). A unique characteristic of this ware is the common occurrence of a wash or pseudoslip of red ocher on the inner surface of bowls and sherds. This coating, which is often rather brilliant, can generally be removed by rubbing, but occasionally it appears to have been baked in. The use of this red pseudoslip is not a late trait, as it occurs on the inner surface of about the same proportion of protohistoric Pawnee pottery as well as on one type of prehistoric ware. Since the mineral powder present in such bowls would make very unpleasant eating, it seems probable that this type of ware had certain ceremonial functions, a usage further indicated by the unique lid already mentioned. Summing up the matter of historic Pawnee pottery of the late eighteenth and early nineteenth centuries, we can say that it seems to furnish a reliable clue concerning the group affiliations and period of any site at which it may be found. It further forcibly illustrates the degeneration of the ceramic art following the adoption of horse culture and the nomadic life thus engendered.

Stone artifacts are still numerous at Pawnee sites of this period. For purposes of comparison with the artifact complexes of other Nebraska cultures we may summarize Wedel's historic Pawnee data. In the following list of archaeological criteria thus indicated, those non-perishable artifact types which, so far as Nebraska cultures are known at present, seem especially characteristic of Pawnee culture in this period, are italicized.

Historic Pawnee ceramic type.

Metates, rare. One recorded from the Hill site, one from the Skidi site near Palmer, Nebr.

Small rectangular manos, fairly common.

Cupped anvil stones of various sizes, very common.

Arrowpoints, rather rare. A few finely chipped and notched stone points and about the same number of iron points recovered.

Large, flat side scrapers, very common. These are usually crudely chipped quartzite having one edge rounded for holding and are especially typical (pl. 1, fig. 2, a, d).

Small planoconvex end scrapers, very rare.

Rubbing stones, common.

Discoidal hammerstones, common.

Pecking stones, common.

Stone balls, fairly common (usually from graves).

Polished quartz pebbles and crystals, rare (usually from graves).

Grooved mauls, fairly common. Rather crude.

Grooved axes, rare. A few straight-backed, three-quarter grooved, long-bladed specimens from surface at Linwood site.

Celts (polished), rare.

Celts (chipped), rare.

Stone "molds", not abundant, but several found in graves and in houses at both Hill and Linwood sites. They are of close-grained red stone with deep, broad designs cut into them.

T-shaped and straight small chipped drills. Rare.

"Whetstones" (elongate pieces of limestone, schist, or sandstone), common in graves. Associated with left hand of 80 percent of the adult male skeletons at the Hill site.

Sandstone shaft polishers (in pairs), fairly common (pl. 1, fig. 2, e).

Stone elbow pipes, common. Usually of callinite (pl. 16, fig. 2, l).

Bone and antler artifacts are likewise numerous. Bison scapula hoes, for example, are often found in the same cache pits with an early type of iron hoe. Shell artifacts are less common. The main types are as follows:

Short bone awls, fairly common. These are usually of poor workmanship.

Rib shaft straighteners, common. This type (illustrated in pl. 6, fig. 1, c, from a prehistoric ossuary) is rare in Nebraska save for protohistoric and especially historic Pawnee sites, where they are common.

Bison ulna pick, common. (See pl. 18, fig. 1, a, for similar type from prehistoric site.) They are most common in historic Pawnee sites.

Elk antler hide-scraper handles, fairly common. Unknown as yet in protohistoric or prehistoric horizons.

Bone paint "brushes", common (pl. 1, fig. 2, c). Unknown as yet in protohistoric or prehistoric horizons.

Bison rib beaming tool, fairly common (pl. 1, fig. 2, b). Unknown as yet in protohistoric or prehistoric horizons.

Scapula hoes, common (pl. 6, fig. 2, d).

Toothed fleshers of bone, common (pl. 1, fig. 2, f). Unknown as yet in prehistoric horizons.

Bone "plume holders", rare (several from Hill site). Unknown as yet in protohistoric or prehistoric horizons.

Antler knapping tools, rather scarce.

Antler or bone bracelets, not reported.

Perforated animal teeth, fairly common. (See pl. 9, fig. 2, *h*, for similar artifacts from prehistoric site.)

Animal jaw "corn shellers", common.

Ornamented animal skulls (one wildcat with brass buttons for eyes).

Bison horn spoons, fairly common in graves. (These are very perishable and may have disappeared in more ancient sites.)

Notched mussel-shell spoons, rare.

Cylindrical shell "ear ornaments". Occur rather often in pairs in graves.

Small tubular shell beads, rare.

Bone beads, not reported.

Owing to their perishable nature wooden artifacts are rare in all sites of any antiquity. Nevertheless, a number of types have been recovered in historic Pawnee sites.

Wooden mortar with legs, one found at Hill site. (According to historical evidence these were in common use.)

Wooden bowls, fairly common (from graves).

Wooden platter, one found in grave at Hill site.

Cradle board, a considerable number of fragments found in graves at the Hill site.

Glass beads, very numerous, especially in graves.

For the same reason as the above, woven artifacts are also rarely encountered by the archeologist. However, the numerous graves opened at the Hill site have furnished some material of this sort.

Bison hair cloth, several fragments from graves.

Bison hair yarn, numerous fragments from graves.

Twined rush matting, numerous fragments from graves and houses.

Thus, not including the more perishable types which may have vanished from more ancient sites, we have 12 artifact types especially characteristic of historic Pawnee culture. These are, first, a unique type of pottery, then, large crude quartzite scrapers, grooved mauls, stone "molds", "whetstones", catlinite elbow pipes, bison rib shaft straighteners, elk antler hide-scrapers handles (elbow type), "paint brushes" of spongy bone, bison rib beaming tools, toothed fleshers of bone, and cylindrical "ear ornaments" of shell. To these might be added the mano, cupped anvil stones, grooved axes, and bone "plume holders". The other nonperishable artifacts not listed occur more or less commonly in other Nebraska cultures. The fact of individual inhumation in hilltop cemeteries is likewise a distinctive historic Pawnee trait so far as our present knowledge of Nebraska cultures is concerned. These occurrences will be discussed later in connection with the other cultures so far distinguished in the State. The development of the Pawnee house type and other similar matters will likewise be considered at that time.

In addition to the later and documented Pawnee sites just described the University of Nebraska Archeological Survey has also surveyed and excavated in two large and important protohistoric sites apparently of the same culture but representing a somewhat earlier period (map, fig. 1, sites 11, 12). These protohistoric villages are not only located in the very heart of the Pawnee territory but also contain much internal evidence linking them with the historic Pawnee culture as revealed by archeology. Both have already been described in some detail by Wedel,⁵⁹ although complete reports of later excavations carried on during the summer of 1931 are in preparation. For our present purpose it will suffice to sum up the general characteristics of the culture thus revealed in order to facilitate comparison with other and prehistoric cultures. The first of these is called the Burkett site and is located above the Loup River 4 miles southwest of Genoa in Nance County. The other, called the Gray or Schuyler site, is larger, being strung out for some 2 miles along a ridge between Shell Creek and the Platte 2 miles north of Schuyler, Colfax County. Judging from the relative amount of metal and glass remains recovered from each, the Burkett site appears to be the older of the two, though both represent the same general culture horizon. So far no horse remains have been reported in excavating either of these sites, whereas such skeletal material is abundant in the historic Pawnee villages circa 1805. This occurrence of rather rare Caucasian artifacts of metal and glass in sites in which horse remains are either scarce or entirely lacking is significant and offers a means of dating the culture with relative accuracy. Such artifacts could hardly have reached the Pawnee prior to 1540 and Robert La Salle reports horses as being numerous in the Pawnee villages by 1682, hence the present culture must fall between these two dates, giving us an approximate median dating of 1600 for the protohistoric Pawnee culture as revealed in the Burkett and Gray sites.

Leaving for future publication the presentation of this evidence in full, we will briefly sum up the salient characteristics of the rich culture so far revealed in these two sites. Both villages are scattered over considerable areas without any apparent order and lack any visible fortifications or earthworks, though both sites are marked by numerous low mounds or refuse heaps between the houses.⁶⁰ In neither site are the house remains marked by pits, and the earth lodges appear to have

⁵⁹ Wedel (no date). See Burkett and Schuyler sites. As previously mentioned, Hayden (1868) and Blackman have briefly described certain aspects of these protohistoric villages.

⁶⁰ See Wedel, no date, for further details.

been built on or only a few inches below the surface of the ground. At the Schuyler site one of the largest and finest houses of the Pawnee type yet reported was excavated by Wedel in the summer of 1931. This house, the floor of an earth lodge, was 49 feet in diameter, had 4 large central posts, an intermediate circle of 15 posts, and an outer circle of 112 posts. The entrance passage, lined with posts, was in the eastern part of the house, and there were seven large cache or storage pits in the northwest quadrant of the floor area. Another house here of somewhat similar nature but very poorly defined was also partially excavated. Two houses have been excavated so far at the Burkett site, one by the writer in the spring of 1931 and another by Wedel in the summer of that year. The two houses were very similar, having 4 central posts and only one outer row of 12 posts, with entrance passages to the east. The floor plan of the house excavated in the spring of 1931 is given here (fig. 3). These houses resemble that at the Schuyler site in being perfectly round in general plan, but are small and lack the outer row of post molds. Only the second of the Burkett site houses contained a cache pit, the house here figured lacking them. The protohistoric caches are generally similar to those of the historic period but the survey parties located no outside storage pits at the Burkett site, though they have been reported at the Schuyler site. Particularly interesting is the consistent use of four central posts in these protohistoric Pawnee houses in contrast to the characteristic six or eight employed in the later historic lodges. Since the four directional house posts played an important role in all Pawnee ceremonial symbolism their uniform occurrence in this earlier culture is undoubtedly significant.⁶¹ It tends to refute Linton's interpretation of the larger number of central posts in the historic Pawnee lodges as being an example of late and incomplete borrowing from the Arikara or their Siouan neighbors.⁶² Rather it would seem that the trait was an old one in Pawnee culture that had disappeared in historic times save for certain ceremonial vestiges. Equally interesting is the typical buffalo skull shrine in the first house excavated (fig. 3). It was located directly opposite the passageway, between the four central posts and against the western wall on a slightly raised earth platform. The skull had been burned, apparently on the destruction of the lodge, but with it were charred "shrine sticks" and the only Caucasian artifacts found in the house, a few crude and possibly native-made glass beads and small pieces of sheet copper, testifying to its cere-

⁶¹ See Murie, 1914, for the symbolism connected with the four-post motif.

⁶² Linton, 1924, pp. 247, 248; compare Wedel (no date).

monial significance. No such shrine or altar was found in the second house excavated. Thus the protohistoric house type is practically identical with that of the historic Pawnee save that the one house at the Schuyler site is technically superior to any of the latter so far excavated, and the earlier houses cling to the four-post central foundation.

Very little is known of the protohistoric Pawnee burial complex. Wedel found a semiflexed adult skeleton in a cache pit at the Schuyler

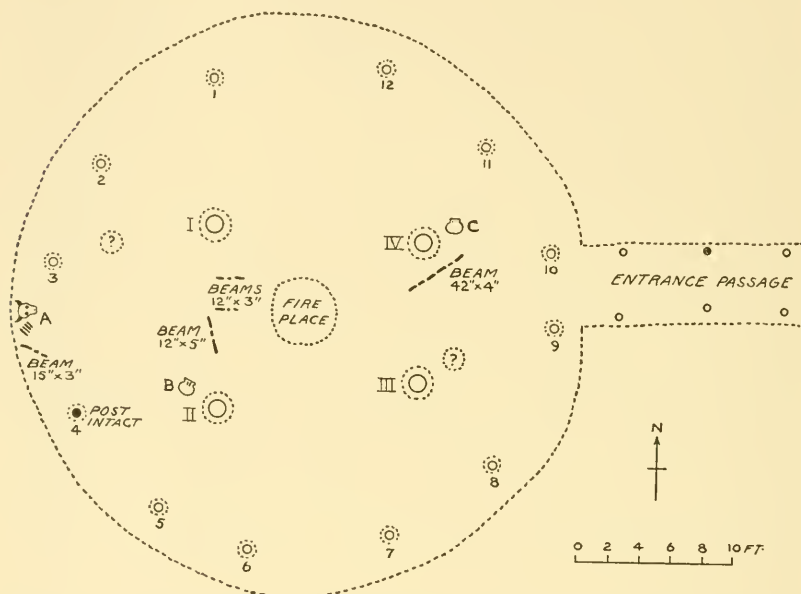

FIG. 3.—Floor plan of protohistoric Pawnee earth lodge, Burkett site, Nance County. I-IV, central posts; 1-12, outer posts; A, burned buffalo skull shrine; B, C, broken pots; ?, extra post molds or pocket caches.

site in June 1932 and mentions unverified reports of sitting burials from the same place. Blackman (1924, p. 7) has described an ossuary at the Burkett site which, if verified by future research, may prove to be an important link with prehistoric cultures in Nebraska. So far no hilltop burial grounds have been reported from the vicinity of these sites.

The ceramic remains from both the Burkett and Schuyler sites are strikingly similar and of the finest type so far reported from Nebraska. Both sites are astonishingly rich in broken pottery, which occurs in abundance in house sites and refuse heaps. This pottery was first

figured by Holmes and has since been described by Wedel,⁶³ hence we need only discuss its major characteristics. Complete restored pots (pl. 3) and characteristic rim sherds (pl. 2) are figured here, and these, in conjunction with the illustrations given by Holmes and Wedel, present a good picture of protohistoric Pawnee pottery. This ware appears to have been the product of a living ceramic art, variable and well executed in its forms and showing none of the careless formalized technique so marked in the historic Pawnee pottery. In protohistoric Pawnee ware a gray paste predominates, often fired to a light-brown color and tempered with fine sand or crushed stone. It is similar in texture to the better grade of historic Pawnee pottery but is usually better polished on the outer surface. Presumably it has been shaped by the paddle and anvil method, or by lump modeling, since no evidences of coiling have been noticed. The occurrence of vertical ridges on the body of many of these pots is hard to explain (see pl. 2, fig. 2, *d, l*; pl. 3, *a, b*, and Holmes, 1903, pl. 177, upper left-hand corner) but is a rather characteristic feature of the ware and may be the result of molding the pots within a willow twig frame as described by Dunbar.⁶⁴ Decoration is characteristically accomplished by incision and to a lesser extent by modeling, but a small percentage of the sherds have a red ocher slip or wash on their inner surface, as is also the case with historic Pawnee pottery. The decoration of lips, rims, and handles with angular incised designs is rather ornate and pleasing to the eye (pl. 2). Curvilinear and cord-marked designs such as occur on Mandan pottery (compare Will and Spinden, 1906, pls. 37, 40) are totally absent, though the ridged surface texture and many of the geometric designs occurring on the Mandan sherds are strikingly similar to some of the protohistoric Pawnee pieces. While a considerable proportion of the Burkett and Schuyler site rims are simple and direct (pl. 2, fig. 1, *k, l, m*) others have marked collar with incised designs (pl. 2, fig. 2, *g, h*, and Holmes, 1903, pl. 177, lower right-hand corner) which closely approximate both the historic Pawnee (pl. 1, fig. 1) and certain prehistoric Nebraska pottery types to be discussed later (pls. 5, 9, 21, 24). On the whole, however, the shouldered rims or collars on the protohistoric pottery are less pronounced than in either of the foregoing wares. Instead, the protohistoric Pawnee pottery makers seem to have run to broad loop handles (pl. 2, fig. 1, *a-g*, fig. 2, *a-e*) or to a pot marked by an outward curling lip and a whole series of loop handles, often

⁶³ Holmes, 1903, figs. 78, 79, and pl. 177; Wedel, no date. The photographs of restored pots, pl. 3, were made available through the courtesy of Dr. E. H. Bell.

⁶⁴ Cited by Grinnell, 1893, pp. 255-256.

elaborately incised, extending from lip to shoulder (pls. 2, fig. 1, *b*, fig. 2, *a*). Cord marking occurs but rarely in the protohistoric pottery, apparently being replaced to a great extent by the peculiar vertical ridges already noted. As can be seen from our restored pots (pl. 3), the reconstructions drawn by Holmes (1903, fig. 78) are very accurate as to the characteristic round or semi-pointed body shapes of the complete pots.

In addition to the more characteristic pottery forms several unique types with numerous spouts or with a flat canteenlike shape have been recovered at these sites. Certain of these appear to be trade pieces which may prove to have important historical connections. This is especially true of a number of shell-tempered and, in some cases, incised sherds found at the Schuyler site. The only other pottery artifacts are a very few modeled tobacco pipes (see Holmes, 1903, fig. 79) and more numerous small, ground-down pottery disks which are usually perforated (pl. 11, fig. 2, *a*). The latter owing to the small size of the perforation do not seem to have been used as spindle weights, but their function is as yet undetermined.

Until the considerable amount of archeological material obtained by the Survey from both the Burkett and the Schuyler sites has been carefully studied in detail, no full treatment of protohistoric Pawnee culture is possible.⁶⁵ However, for purposes of the present comparative study we may briefly list the main artifact types noted at the time the excavations were in progress, though such a list must obviously be incomplete and subject to correction. Stone artifacts are rather numerous.

Small, slightly dished mortars occur, though metates and manos have not been reported.

Arrowpoints, characteristically very small and triangular in shape, lacking either stem or notches (NBa, fig. 7), very numerous (pl. 7, fig. 1, *i*).

Stone knife blades, common. Diamond-shaped and beveled type characteristic.

Large flat side scrapers of quartzite, fairly common, especially at Burkett site.

Small planoconvex end scrapers, very common. Usually very short but some long and narrow examples from Schuyler site.

Rubbing stones, common.

Discoidal hammerstones, common.

Pecking stones, common.

Stone balls, not noted.

Polished and perforated gypsum crystals, quartzite pebbles, and hematite paint nodules, all noted.

Grooved mauls, large and heavy examples fairly numerous.

Grooved axes, not reported (probably rare or lacking).

Polished celts, not reported (probably rare or lacking).

⁶⁵ Such a study is being prepared under the direction of Dr. E. H. Bell.

Chipped celts, fairly common (also chipped "hoes" common).

Stone "molds", not found.

T-shaped stone drills or awls, fairly common.

"Whetstones", not reported.

Sandstone shaft polishers, common.

Stone elbow pipes, both catlinite and "pipestone" specimens found.

Platform pipe (one unbored specimen found at Schuyler site).

Bone and antler artifacts are likewise rather abundant :

Bone awls, various sizes, fairly abundant.

Rib shaft straightener, very common.

Antler shaft straightener, not reported.

Bison ulna pick, present.

Elk antler hide-scrapers handle, not reported.

Antler pick or punch, present.

Bone paint "brushes", not reported.

Bison rib beaming tool, not reported.

Scapula hoe, common (pl. 6, fig. 2, *c*).

Toothed fleshers of bone, rare (1 found at Burkett site).

Bone "plume holders", not reported.

Antler knapping tools, not reported.

Perforated animal teeth, not reported.

Antler or bone bracelets, fragments found.

Animal jaw "corn sheller", not noted if present.

Ornamental animal skulls, etc., one complete skeleton of mammal (badger?) covered with purplish red pigment in refuse heap at Burkett site.

Bison-horn spoon, none recovered.

Mussel-shell spoons, not noted.

Cylindrical shell ear ornaments, not found.

Small tubular shell beads, not reported.

Tubular bone beads, present at both sites.

Neither wooden artifacts, textile materials, nor vegetal remains have been recovered from either of these protohistoric sites. The absence of remains of such materials is apparently due to the greater age of the Burkett and Schuyler villages than that of the historic Pawnee villages previously discussed. Similarly, bison horn cores and other fragile skeletal material occurs at the Hill site, whereas it is lacking in the protohistoric villages. The fact that historic Pawnee cemeteries as well as village sites have been opened, whereas in the protohistoric Pawnee sites the cemeteries or ossuaries have not been located, must be considered in comparing the totality of the two cultures. Concerning Caucasian contacts the Burkett site yielded a few blue-green, poorly crystallized glass beads, some small copper beads, and strips of sheet copper, and the Schuyler site contained bits of iron, copper leaf, a tubular copper bead, and a few gun flints. No horse remains were found in examining the animal bones at the Burkett site. The animal

skeletal remains from the Schuyler site have not yet been fully reported on.

Considering the relationship of this older culture to that of the historic Pawnee we find that the former contains just one-half of the peculiarly characteristic Pawnee artifact types, namely, a more abundant, richer, but rather similar ceramic type, large flat side scrapers (quartzite), grooved mauls, catlinite elbow pipes, bison rib shaft straighteners, and toothed fleshers of bone (the latter rare in protohistoric sites, however). Besides these, the two cultures share many common artifact types such as chipped celts and hoes, hammer stones, rubbing stones, pecking stones, shaft polishers, bone awls, bone and antler picks, bone beads, and scapula hoes. Of the more unique artifacts, both phases of culture possess perforated or polished quartz crystals and decorated animal remains. On the other hand, the protohistoric culture is particularly characterized by tiny triangular arrow-points, flaked stone knives, an abundance of short end scrapers, T-shaped chipped stone drills, platform and clay pipes, and fragmentary antler or bone bracelets. Moreover, the protohistoric sites are much richer in every respect, except Caucasian artifacts, than are the historic Pawnee sites. When the protohistoric interments have been excavated, the greater richness of such sites may be even more strikingly emphasized. There is evident a strong linkage between the two cultural phases, but the earlier horizon is the more elaborate and contains many native artifact types that had already disappeared prior to the advent of American explorers in the Pawnee territory.

PREHISTORIC SITES RECENTLY EXCAVATED IN NEBRASKA

So far we have been considering the general problems of our immediate region, its historical and environmental background, and the previous archeological research therein accomplished. In addition, the concrete outlines of one of the major historic cultures of the State, namely, the evidences of Pawnee occupation, have been sketched in. It remains to present the new evidence on prehistoric archeology.

The following sections deal with scattered prehistoric sites in south-central, central, and extreme western Nebraska (see map, fig. 1 and table 4, p. 246). These were excavated in an attempt to outline major cultures within the State as suggested by earlier excavations, examination of local collections, and reconnaissance work by members of the survey parties. Rather than spend all available resources on a complete surface survey of the State, the writer attempted a less ambitious survey coupled with actual excavation in chosen sites that gave

promise of wider correlations. It is this evidence that is now presented. First, a series of village and ossuary sites in south-central Nebraska are considered. Then a series of village and ossuary sites in eastern Nebraska, all the latter belonging to the prehistoric "Nebraska culture" of Gilder and Sterns, are discussed. Next, the important Walker Gilmore site near Rock Bluffs, Cass County, where the Nebraska culture is superimposed over an earlier and very different horizon, is dealt with at some length. Following this, other sites not fitting into any clearly distinguished culture group are referred to, and, later still, sites incompletely known but important in this initial attempt to trace the spread of known prehistoric cultures are mentioned. Last of all, recent finds revealing the earliest known evidence of man in Nebraska will be considered.

Reference to the map of sites (fig. 1), coupled with the map of geographic areas and tribal domains (fig. 2), will aid the reader in following this necessarily incomplete account. We are here dealing with a huge area of which a great, indeed the greater, part is still unknown from the archeological standpoint. That the limited work already accomplished will give a complete outline of Nebraska prehistory is not to be expected, but perhaps the beginnings of such an outline may emerge.

VILLAGE ON LOST CREEK (DOOLEY SITE), FRANKLIN COUNTY

On the south side of the Republican River near its junction with a small stream known as Lost Creek is a large aboriginal village site of prehistoric origin (fig. 1, site 13; fig. 4). Traces of former occupation are to be found over many acres of creek bottom and hill slope, and several similar sites occur farther south along Lost Creek. The place where Lost Creek enters the Republican River is marked on the west by steep walls culminating in bare river terraces. To the east, however, the land gradually rises to a series of low, rounded hills. These hills and the lower lands are nearly all under cultivation at the present time, and the plowed fields are marked by abundant potsherds, flint work, and other cultural detritus. Owing to its size and the present state of cultivation, no detailed map of the entire site was obtained, but a former population of considerable size is indicated. The concentration of artifacts and camp debris in certain small areas over the plowed fields marks the location of numerous lodges, and the general similarity of the potsherds and other cultural evidence over the entire site suggests an occupation more or less uniform in composition and in time. The fact that no traces of white

contact have been found in this village gives a minimum age of some 350 years for the site, although it may be much older.

Prior to the wholesale breaking up of the prairie sod Lost Creek was evidently a sizable stream at all times of the year, and its steep western banks, some 50 feet high, testify to considerable cutting power. At the time of our visit, July 8-27, 1930, the lower course of the stream was bone dry, and only a few pools marked its southern extension. In time of heavy rainfall, however, the stream still carries a large amount of water. Cottonwoods, willows, bur oaks, elms, and other deciduous trees grow thickly along the river and creek beds, but beyond the draws leading into such bottoms the rolling hills are devoid

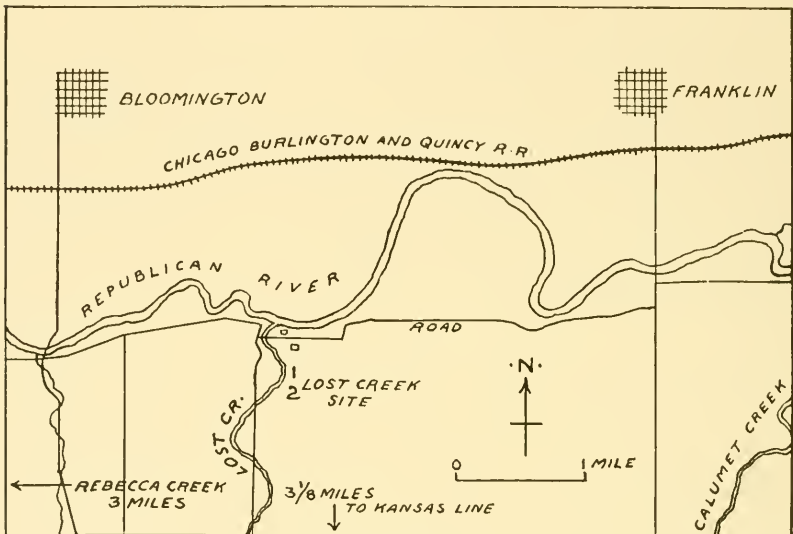

FIG. 4.—Sketch map of Lost Creek district, Franklin County. 1, 2, earth lodges at Dooley site.

of trees. The soil of the hills and bottoms is a fertile sandy loam favorable to both recent and ancient cultivation. In the course of cutting its channel Lost Creek has exposed beds of limestone which contain layers of brown and yellow jasper. The jasper is mostly of a poor grade, though some clear deposits of the mineral occur. The poorer quality jasper takes the form of thin layers which break off in slabs ranging from a few inches to several feet in horizontal dimensions and only a few inches in thickness. Both the clear jasper and the slabs were employed by the natives in the manufacture of stone artifacts and occasionally for flooring material. This juxtaposition of wooded river bottom, rolling plains, and surface jasper quarries made the general site exceptionally favorable for aboriginal occupation.

Our excavation work in this region was prosecuted on a farm then owned by T. Dooley, situated on the east bank of Lost Creek about one-eighth of a mile from its junction with the Republican River. Previous digging here by local collectors from Franklin and nearby towns had revealed much of archeological interest. This work carried on in 1928 and 1929 was largely unorganized, few notes were taken, and the specimens were scattered. However, through the courtesy of one of the workers, Karl Spence, of Crawford, Nebr., I have been able to compare some of this earlier material with that which we obtained. Mr. Spence kindly sent me photographs and descriptions of his extensive collection from this site. This data I have incorporated under the heading "house 2," at the close of the present section.

The site which we selected for excavation was a small flat some 40 feet above the present bed of Lost Creek and separated from larger flats on both the north and the south by wide draws or former creek channels. The little island or miniature mesa thus formed was again almost cut in two from east to west by a smaller draw or dry wash. The bulk of the earlier digging had been carried on to the south of this little draw and along the steep banks of Lost Creek. The banks at this point drop steeply to a small shelf about 35 feet below, and then vertically for 10 to 12 feet to the present water level. The old houses were located on the uppermost level, and the steep creek banks had been used as a place for dumping refuse; ashes, broken pottery, and artifacts were formerly thickly deposited along the rim. Unfortunately, relic hunters had torn up most of these deposits and had so honeycombed the edge of the bank that the owner was obliged to forbid further excavation here. Since the bulk of the digging back from the banks occurred south of the small draw previously mentioned, we centered our first exploration work on the north side, which had been relatively little dug over. The whole flat in question had never been under the plow, having been used as pasture land. While it formed part of the bottom, inasmuch as the low hills to the east were almost a quarter of a mile away, it had no timber other than low shrubs, the larger trees at this point being confined to the creek bed and the deeper draws.

Since there were no surface indications of house pits, we ran our first trench through a depression parallel to the edge of the bank where local collectors reported much material had been found (fig. 5, excavation 2). A trench 20 feet long, 3 feet wide, and 3 feet deep yielded some artifacts but no subsoil indications of any house structure. A few potsherds, some worked jasper and chips, as well as two bison

teeth were found between the depths of 12 and 24 inches. At a depth of 3 feet an irregular mineral deposit of white nodules and streaks was encountered at all points in the trench. This deposit occurs at about the same depth along the cut banks of the creeks and is natural in origin.

Abandoning this trench, we crossed the small draw to the much dug-over area to the south. Here we dug three trenches, respectively

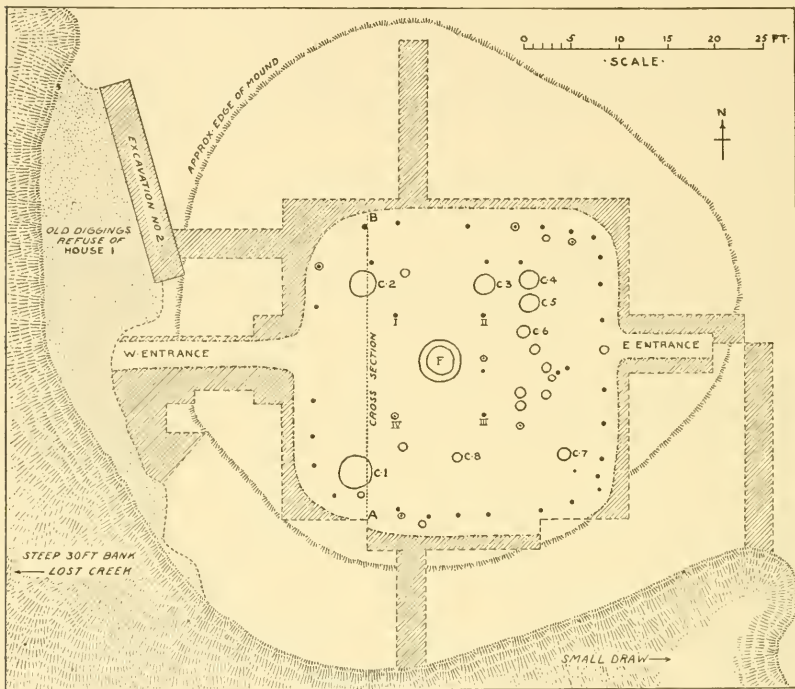

FIG. 5.—Floor plan, house 1, Lost Creek. Hachures, excavated area outside house; outline of house enclosed by dot and dash lines; I-IV, central posts; C1-8, cache pits; small circles, pocket caches; black dots, posts or post molds; dots within circles, either post molds or pocket caches; A-B, cross-section shown in figure 6.

20, 15, and 9 feet in length by 3 feet in width and depth, all radiating out from the area of most intensive digging. This excavation (no. 3) is not shown in figure 5, but occurs about 100 yards southeast of excavation 2. Identical conditions to those in excavation 1 were encountered, scattered charcoal, debris, and artifacts occurring between the depths of 12 and 24 inches, but no traces of any house construction were found.

During this preliminary work we were obsessed with the idea that house remains would be encountered in the depressions of the pasture

rather than in the few elevated areas, which we avoided. Our preconceptions in this case were due to earlier experience along the Missouri River, where old lodges are marked by pits as the result of their original subterranean nature. Fortunately, we were joined at this time by A. T. Hill, who informed us that the house previously excavated here had been marked by a low mound. With his assistance, and after sinking numerous test pits, we selected a small rise just southeast of excavation 2, which proved to be a house site, apparently closely similar to that which had been torn up on the south side of the small draw.

METHODS OF EARTH LODGE EXCAVATION

Prior to discussing this site in particular it may be well to devote a short space to the matter of house site excavation in general. In our earlier work in Nebraska trenching methods were employed both to facilitate refilling and because in many cases it was impossible to leave a larger excavation open between week-end trips. Allowing for the inevitable modifications of technique at certain sites, our system was generally as follows. Having determined the circumference of the mound (or pit), its height (or depth), and the central point, four large datum posts were set up at the cardinal points well beyond the assumed edge of the house itself. A diagram or floor plan was then made, dividing the entire area into 3-foot squares, lettered from north to south and numbered from east to west. A row was then dug out from north to south in the center completely bisecting the mound (or pit) and extending well beyond and below the house structure thus cross-sectioned. The dirt thus removed was piled on the east side of the trench so that the west half of the house could be completely excavated. In this way the dirt pile could be kept just behind the advancing workers. Each section was carefully measured and staked off, each worker removing a 3-foot section at a time (pl. 12, figs. 1, 3). As each north-to-south row was removed the west wall thus revealed was diagramed. The depth of the excavation in all places reached into undisturbed soil, and a progressive series of house cross-sections was thus obtained. Having completed the western half of the house we returned to the center, and having cleared off and excavated the first row to the east, the work was similarly carried on to the eastern limits of the house. Naturally, the trench was narrowed down in following out passageways (fig. 5).

The necessity of returning to the center of the house and removing the dirt heap here prior to excavating the second half may be avoided by starting the initial trench on one edge of the house site and carrying

it completely through to the other. In practice, however, it is often so difficult to locate the edge of the actual house area prior to excavation that a central trench cleanly outlining the structure is apt to save time and energy.

All important artifacts and structural features were thus recorded on separate diagrams as the work progressed, and in theory, when these were assembled they should have given a complete reconstruction of the site in question. The actuality, however, often left a great deal to be desired. Only those who have worked in sites of this nature where almost no solid structural features remain can appreciate the difficulty involved in reconstructing the exact nature of a house from evidence thus recorded. The older the site the more will rodents, insects, and roots have disturbed the original features of the earth-lodge structure, which naturally lacks any solid walls or floors differing in basic material from the surrounding earth.

For this reason in all our later work we uncovered the entire floor of the lodge at one time, removing the earth with wheelbarrows. In this way we were able to go over every inch of the floor with trowels in our search for post molds or other structural features, thus avoiding the unpleasant discovery that despite the best of intentions we must have overlooked such features, which, under the former system, would already have been covered up by our dump heap. The matter of features above the floor in this latter form of excavation was taken care of by charting them in as the digging progressed. The matter of soil layers above the floor may also be determined by leaving a datum square of earth in the center of the house which may be compared with the walls of the excavation beyond the edges of the floor. I mention this last type of excavation at this point because I believe it to be by far the best method for exploring the earth-lodge type of dwelling. However, since the excavations covered in the present report were for the most part carried on during the early part of our Nebraska work it may be taken for granted, unless otherwise stated, that the trenching system was employed.

HOUSE I

In house 1 there was little or no surface indication of any dwelling other than a low mound not more than 16 inches higher than the surrounding pasture land and roughly 60 feet in diameter. The mound was irregular in outline, with its greatest height along the north-and-south axis, although it was hardly noticeable as a rise in the rough pasture land. Its artificial nature was only determined by test pits, as there was no cultural evidence on the surface.

Excavation by trenching in the manner previously outlined disclosed the remains of an earth lodge in the form of a rounded square with the four walls closely oriented to the four points of the compass (fig. 5). Two entrance passageways led from the center of the east and west walls, respectively. The walls were approximately 30 feet in length and the outer boundaries of the house were marked by 27 burned posts or post molds. The fireplace, slightly more than 3 feet in diameter, was located in the center of the north-and-south axis of the house but about 3 feet west of the true center. Two large cache pits were located in the northwest and southwest corners of the house and some 10 smaller caches and "pocket" caches were also noted. In several cases it was impossible to tell whether a post mold or a pocket cache was represented by these subfloor excavations, and only where vertical charcoal or wood was encountered did we designate it as a post. The distinction between definite posts, pocket caches, and indeterminate subfloor excavations has been indicated (fig. 5). A

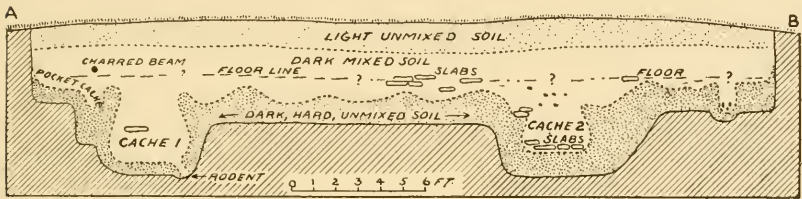

FIG. 6.—Cross-section of house I, Lost Creek. Hachures indicate unexcavated soil.

typical cross-section of the house mound is also shown (fig. 6), the outlines of the two largest cache pits appearing in this diagram. The diagram also illustrates the relative depths of the main soil strata to be distinguished, and indicates rather well the manner in which the floor line has been broken down in places by the long-continued activity of rodents, insects, roots, and other disturbing agencies.

Our excavations indicated that the upper foot of soil was barren of artifacts or human debris, except where these had been brought up by the burrowing of rodents. This layer consisted of a light yellow sandy loam and had evidently been deposited over the site subsequent to its abandonment. Below this to the depth of approximately 3 feet (from the surface) the soil was darker and mixed with charcoal, ash, and human detritus. The old floor line was indicated by a very wavering black line, hard-packed in places, and marked by a somewhat greater concentration of charcoal, artifacts, and debris. In the central portions of the mound the depth of this floor line averaged 30 inches, decreasing slightly in depth toward the edges of the mound.

From the evidence revealed by all cross-sections made in excavations 1, 2, and 3, the following interpretations seem justified. First, that the upper foot of soil over the area in question is of natural origin and has accumulated since the site was abandoned. This is indicated by its uniformly unmixed nature. Second, that the mixed soil over the general site from a depth of 12 to 24 inches, approximately, had accumulated during the period of occupancy. This is indicated by the fact that the excavations extending outside the boundaries of house 1, as well as those on the flat outside of any house sites (excavations 1, 2), all showed scattered human refuse throughout this layer. Third, that the human detritus found in house 1, from a depth of about 24 inches to the lowest point of mixture (cache 1, 6 feet 3 inches), was due to the nature of the house in question. The floor line (averaging 30 inches deep at the center) is some 6 inches below the bottom of the mixed soil outside the house site. This apparently indicates that the house floor had been excavated originally to only about this depth below the then surface of the surrounding soil. Such an interpretation of the evidence accounts for the collapsed earth lodge forming a low mound rather than a depression such as occurs where a deeper pit has been dug. It also agrees with the internal evidence of the various excavations already mentioned.

Unfortunately, no accurate data are available for estimating the time element involved in this accumulation of about 12 inches of mixed soil prior and 12 inches of unmixed soil subsequent to the abandonment of the site by its original inhabitants. Such a deposition of soil other than by human agency and wind action, must have been due to wash from the low hills to the north and east. Owing to the almost level nature of the treeless flat on which the house is located and to the very gradual slope beyond this to the hills in question, the filling-in process would presumably have been rather slow. The lack of any traces of white contact alone gives the site a minimum age of 350 years, but beyond this we must leave to future physiographic research the problem of the actual time involved during its occupation and since its abandonment.

The floor plan of the house itself is shown in figure 5 and plate 4, figure 1. Its square form with rounded corners is unlike any other lodges previously excavated on the Republican River. On the other hand, its very shallow semisubterranean floor, its outer and inner post holes, central fire place, and internal cache pits bear a generic resemblance to the historic Pawnee lodges of that region previously described. Unlike the latter sites, however, the floor line of this lodge had been badly broken up and, compared to the Pawnee lodges of

circa 1800, was difficult to trace. In this regard it is apparent that the older the site the more broken up will be the lines of soil stratification, owing to the long-continued work of insects and rodents. In all cases but one the posts had rotted away except for small crumbling pieces of charcoal and rotted wood. Each post, however, thus left a mold somewhat larger than itself which could often be cleaned out by hand without the use of tools. The outer post molds averaged about 10 inches in diameter, suggesting a post about 7 inches in thickness. These outer posts appear to have been vertical rather than leaning outward as occurs in historic Pawnee lodges; however, lacking the actual posts themselves, this is not positive. One post in the southeast corner was more or less intact below the floor line, consisting of two slabs of bark filled with yellow earth, ash, and charcoal. The bark crumbled on exposure but appeared to be a soft wood, perhaps cottonwood, and the post itself measured 7 inches in diameter. It is possible that not all the outer posts were located, especially on the north and west walls. Their distribution was six on the north, eight on the east, eight on the south, and five on the west, although originally there may have been eight to a side. In every case the upper portions had been burned, while the lower portions had rotted away. Evidences of the floor line extended only about 2 feet beyond the posts.

The arrangement of the inside posts as revealed by the excavation leaves something to the imagination. In many cases it was impossible to distinguish between post molds and small pocket caches, while in others large cache pits or other subfloor excavations made the location of post holes difficult. Four post molds, each about 6 feet from the center of the fireplace, are located in an almost perfect square (fig. 5, I-IV). The northeast post hole measured 12 inches, the southeast 10 inches, the southwest 10 inches, and the northwest 9 inches. The southwest post hole was less clearly defined than the others (fig. 5, IV) but appears to have served this function rather than that of a pocket cache, since it contained considerable charcoal. All of the post molds, both inner and outer, were sunk well below the level of the floor. Judging from the one 7-inch post found more or less intact, the holes were first dug out, the posts set in, and the earth tamped down around them. Just 3 feet south of the north wall three 4-inch post molds occurred on an east-and-west line, but all three were very shallow, penetrating only a few inches below the floor line. They could not have been used as roof supports, and their positions, each 2 feet north of a cache pit, suggest some relationship between post and pit. One 4-inch post mold was located 3 feet from the southeast corner, another of the same size exactly between the NE. and SE.

center posts, and a third 8 feet east of the latter. There were undoubtedly other posts missed in the excavation and, as before mentioned, some of the pocket caches may actually represent post molds retaining no traces of their former wood content.

To judge from the postholes located, it would seem that the four center posts formed the central framework of the lodge. It should be noted, however, that this central framework, as well as the fireplace itself, occurs about 3 feet west of the exact center. The 4-inch post to the east may be one of a pair on either side of the east entrance, but if so no trace of its mate was found. The other 4- and 6-inch posts above mentioned may have served as markers for cache pits, as partitions, or for both purposes.

Clearly defined entrance ways were encountered leading out from the center of both east and west walls. They were marked by a heavy layer of hard-packed ash and clay averaging 3 feet in width and 5 inches in thickness. The eastern passage was traced out 12 feet and the western 20 feet. Starting from floor level (26 inches below ground level on the west, 27 inches on the east) the east passage sloped very gently up about 6 inches in 12 feet. The west passage likewise left the house at floor level just beyond the outer posts, but was level throughout its length. At 20 feet, owing to the westward slope of the ground, it was only 15 inches below the surface. Beyond this, earlier burrowings along the creek bank prevented tracing it. Only one bordering post hole was noted on the north edge of the west passage, 18 feet from the west wall. This contained a very badly disintegrated 4-inch charred post. However, the two narrow, clearly defined passageways extending with even width so far beyond the house walls indicate that they were originally closed in. Possibly all the posts would have been noted had the floor been entirely cleared off instead of being cut through by trenches.

The fire place consisted of a bowl-shaped depression at floor line about 3 feet in diameter. Some 12 inches of white ash and charcoal rested upon 5 inches of red baked clay in the center of the depression. Traces of burned clay, ash, charcoal, burned bone, and other debris extended about 12 inches beyond the fireplace proper.

STORAGE OR CACHE PITS

In all, 21 subfloor storage or cache pits were distinguished in house I. These ranged from large, carefully excavated pits, lined with stone slabs, to small scooped-out pockets hardly to be distinguished from rodent or other burrowings. No cache pits were encountered in any of our trenches outside house I, although they may have been present.

Accounts of the amateur work across the draw rather suggest that they dug out some outside caches, but there is no certainty in this regard. Since comparatively few complete specimens were found in any of the caches it seems probable that they were emptied by their owners when the house was abandoned.

Cache 1 was a bell-shaped storage pit, 6 feet 3 inches deep and 3 feet 6 inches in greatest diameter, located in the southwest corner of the house. A cross-section and the position of the pit is shown in figs. 5 and 6. It had been carefully dug out of the hard magnesia-streaked earth, and its narrow mouth opened just below the floor at a depth of about 36 inches. There was much white ash in the opening, but the lower soil in the cache was dark and much mixed with midden material. This soil could be taken out with the bare hands, in marked contrast to the walls which were extremely hard.

To judge from the manner in which the walls scaled off to a depth of 1 to 2 inches, the cache had evidently been originally lined with wet clay. The floor was flat with rounded edges. The following articles were taken from this pit: 1 worked bison scapula, 1 hammerstone, 1 antler shaft straightener, 4 bone awls, 1 antler flaking tool, 2 cut antlers, potsherds, several fragments of incised antler (?) bracelet, 1 bone fishhook, 3 flint hoes, several broken flint blades, and several fragments of baked wattle and daub with imprints of grass or reed. Two large flat slabs of low-grade jasper, many lumps of baked clay, burned limestone, flint spalls, chips, pebbles, mollusk shells, and various animal remains were also found. Although this was the richest cache found in the house, it too appeared to have been largely emptied by its owners.

Cache 2 was located directly north of cache 1 in the northwest corner of the house (figs. 5, 6). It was shallower than cache 1, being 5 feet 10 inches deep and 3 feet in greatest diameter. Unlike the former, it had a wide mouth and contained very little material. The most striking feature was the flooring of 12 large slabs of low-grade jasper (pl. 4, fig. 3). These were arranged evenly over the floor of the cache, and above the mouth of the cache, about floor level, were a considerable number of other slabs, perhaps having served as a covering. One chipped jasper celt, two bone awls, and some potsherds were the only artifacts in the pit. There was much white ash at its opening but the lower soil was soft, black, and much mixed. There was no clay lining, though the rounded walls were distinct.

According to G. P. Spence, of Franklin, a similar stone-lined cache pit with very little in it was encountered in the older diggings across the draw. Ralph Douglas, of Bloomington, while digging in a plowed field

about one-eighth of a mile west of house 1, had also encountered part of an old lodge floor, 8 by 10 feet, paved in the same manner. Likewise, A. T. Hill, excavating a lodge about 3 miles south of the present site, encountered two areas on its floor, respectively $3\frac{1}{2}$ and 5 feet square, which were covered with evenly laid slabs. As previously mentioned, these low-grade jasper slabs occur naturally in the bed of Lost Creek and by their nature almost suggest this type of use. In the course of our own digging many of these slabs were encountered, and while some gave evidence of having been artificially squared we found no others placed together as flooring.

Cache 3 was a circular pit 3 feet in diameter and 5 feet deep (3 feet below floor line). It was marked by an abundance of baked clay on the floor line at a depth of 27 to 30 inches, perhaps the result of fires having been built over the cache. A considerable number of flat, thin stones occurred at a depth of 32 inches. A few small end scrapers, broken chert blades, bone artifacts, potsherds, and considerable charcoal, ash, mussel shells, and other debris occurred throughout the pit, which was filled with soft dark mixed soil. There was no evidence of any lining to the cache pit.

Cache 4 was a cylindrical pit, being 30 inches in diameter and 4 feet deep. It was filled with dark soft earth containing much ash and charcoal. Aside from a broken jasper hoe and some potsherds, it was devoid of artifacts. There was no evidence of any special floor or lining.

Cache 5 was very similar to cache 4. It, too, was cylindrical in form, being 20 inches in diameter and 4 feet 6 inches deep. Its contents consisted of dark soil heavily impregnated with ash, containing no artifacts other than some flint chips and potsherds.

Cache 6 was somewhat smaller than the last, being marked by a 4-inch layer of pure white ash at floor line and by its greater depth. It measured 18 inches in diameter and was 5 feet deep (from the surface). Six inches from the bottom was a large horizontal stone slab about 19 inches long. Aside from sherds, chips, and bone debris, its dark mixed soil contained no artifacts.

Cache 7 was completely covered at floor line by a thin jasper slab measuring 11 by $14\frac{1}{2}$ inches. The pit itself was small and somewhat narrower at the mouth than at the bottom, being 40 inches deep and 20 inches in greatest diameter. Aside from the covering slab, this pit was typical of all the other pocket caches indicated by unnumbered circles in figure 5, and the photograph (pl. 4, fig. 2) illustrates the type. There was no evidence of any lining to the pit, and its dark mixed soil content was devoid of artifacts.

Cache 8 would have been an ordinary pocket cache but for the fact that it was lined with baked clay about three-fourths inch in thickness. The cache was small, being 11 inches in greatest diameter and 3 feet 6 inches deep (1 foot 6 inches below the approximate floor line). The soil content was of soft dark mixed earth but was barren of artifacts. The lining of the cache was similar to that in cache 1, but unlike the latter it had been thoroughly baked, possibly by the introduction of burning coals into the excavation after it had been coated with wet clay.

The remaining 12 pocket caches indicated in figure 5 present no new features. A cross-section of one of these is shown in figure 6 and, as previously mentioned, cache 7, aside from its slab cover, is also typical (pl. 4, fig. 2). Just what function these small pits may have served is obscure, but they might have been places for hiding artifacts in some cases and a means of burying offensive offal in others.

REFUSE HEAPS

The extensive use of the steep banks of Lost Creek at this place for the deposition of refuse has already been referred to. While engaged in the excavation of house 1, we learned from Ralph Douglas that along the bank just west of excavation 1 and northeast of the house site itself he had earlier dug up a great deal of refuse material. Bones, potsherds, especially rims, broken artifacts, ash, and charcoal had been abundant here, reaching a considerable depth just over and below the edge of this bank. Several fragments of a burned bone bracelet, showing incised designs similar to those on fragments from cache 1 in the house, as well as a number of large baked fragments of wattle and daub with large twig imprints were the most significant finds. Plainly this was the refuse dump for house 1 (fig. 5), and this earlier digging accounts for the fact that only a limited amount of refuse material was found in excavation 1 (just east of the dump) and in our western trenches. Hoping to find a similar refuse heap along the bank south of the eastern entrance, we ran a 20-foot trench south from the passage to the edge of the bank (fig. 5), but no indication of another refuse heap was encountered. To judge from the uniformity of the collections of previous diggers in this refuse heap it would seem that one group and one general period were represented. So far as I could learn, little was recovered in any refuse heaps that was not represented in our findings at house 1.

In general, it appears that house 1 was originally a square, slightly subsurface, earth lodge, with a 4-post central foundation and shorter

posts around the outer margins (fig. 5). The orientation of the walls with the compass and the two opposite entrances on east and west are interesting features. We will discuss its cultural significance in a later section, turning now to the artifacts recovered from it.

POTTERY

Compared to artifacts of stone, bone, and antler, the pottery found in house 1 was not overly abundant. Nevertheless, its complexity and good technique indicates a considerable mastery of the ceramic art. Had we been able to excavate the refuse heap of this house, we would have obtained much more broken pottery, to judge from the collection made at that spot by Mr. Douglas. Rim sherds especially had been thrown out as being awkward underfoot, and the natives generally seem to have been lamentably good housekeepers in this regard. The following list indicates the total amount and main ceramic types recovered:

Complete pots, none.

Restored pots, none.

Total number of sherds, 596 (rim 58, body 538).

Cord-marked sherds, 535 (rim 32, body 503).

Plain ware sherds, 52 (rim 26, body 26).

Incised body sherds, none.

Hematite stained on inside, 9 (rim 0, body 9).

A fairly smooth gray paste predominates in all this ware, which is extremely hard in the finished product. The texture of the pottery appears to be somewhat crumbly, but this is due to the coarse river gravel, or more often disintegrated stone used in tempering. Although the broken edges of the sherds appear crumbly, they are not actually friable, even when roughly handled. Classified on the grounds of crumbling or flaking ware, however, the present pottery might fall into the crumbling class. The degree of coarseness exhibited by the grit tempering is highly variable in individual pieces but, generally speaking, heavy tempering has been used. The pottery is well baked, in most cases showing light gray all the way through, but in a small percentage of the thicker sherds the interior is black, indicating an insufficient firing.

In color a rather dirty gray predominates, light or dark according to the amount of soot present; the inside of the sherd is in almost all cases lighter and cleaner than the outside. All the sherds seem to have come from utilitarian pots. The only exception to this gray ware consists of nine sherds which are stained bright red on the inner surface. The stain appears to be of red iron ocher. On the sherds in question this

stain might be termed a slip, as it cannot be rubbed off and was apparently applied prior to the last firing. The outer surface of all nine sherds is cord-marked and yellow-buff in color. Cross-sections show that the red stain is almost entirely on the surface. Nearly all these ocher-painted sherds came from cache 1, and the type is rather rare in Lost Creek collections generally.

As the foregoing list of pottery types indicates, there is a great preponderance (90 percent) of cord marking on sherds both from the house and from the locality generally. This cord marking is very distinct, generally running vertically up the body of the vessel (pl. 5, fig. 1, *j*) and often at an angle along the rim. It was apparently applied with a cord-wrapped paddle. In a number of cases the pottery had been polished subsequent to the cord marking, thus obscuring the latter (pl. 5, fig. 1, *f*). In thickness the ware is very uniform, averaging 5 mm, with little more than 1 mm variation either way. The sherds are very irregular on their inner surface and give no indications of having been built up by a coiling process; lump modeling, perhaps with anvil and smoothing stone, appears to have been the method employed. The plain sherds as a rule have been well polished and, even the cord-marked ware has a smooth though irregular feel. A considerable amount of soot occurs on both inner and outer surfaces of some sherds, but there is no indication of any maize-oil coating on the pottery. None of the sherds from house 1 is large enough to give any positive idea as to shape. However, the almost complete lack of handles or lugs, the predominance of collars, the sharp angle characteristic between shoulder and neck, and the absence of any sherds suggesting other than round or semipointed bottoms are notable points.

Only one complete pot is known from this particular site and that is in the Spence collection at the Hastings (Nebraska) Museum. Through the courtesy of its owner, Karl L. Spence, I am able to illustrate this specimen (pl. 21, fig. 1, *b*). This small pot, having a capacity of slightly more than a pint, was found by C. A. Duncan, 20 to 24 inches below the surface in house 2. It is of a dull yellowish buff color and is heavily cord-marked. The rim is exceptional in its lack of any collar or flare. No other sherds from the site that I have seen have a similar type of rim. The shape and surface texture, however, are very similar to the general run of Lost Creek pot fragments. Another complete pot in the Spence collection (pl. 21, fig. 1, *a*) was found by Mr. Spence on the C. J. Furry farm, just south of the river bridge at Franklin, Nebr. This pot is about 17.5 cm high by 13.7 cm in diameter and holds about half a gallon. It is dusty gray to buff in color, with vertical cord marking on rim and body. The bottom is semipointed,

and grit has been used for tempering. While the cord marking (instead of incising) on the rim is rather unusual, the shape of rim and collar as well as the color and cord markings on the body, indicate that the pot belongs to the culture represented in houses 1 and 2. Mr. Spence also found a flat, rounded rock or "pot cover" with this vessel which fits the opening perfectly. Since the only two complete pots of this culture known at present (1932) lack decorative features, we must consider the rim sherds from house 1 in this regard.

The decorative elements, if we except the previously mentioned cord marking and rare painting with red ocher, are almost entirely on the rim. This decoration takes the form of modeling (shape of collar and rim) and incision. The main types of rim decoration from house 1 are illustrated in plate 5, figure 1, and more or less representative rim sherds from surface sites are shown in plate 5, figure 2. The latter plate shows some typical sherds from a collection presented by Ralph Douglas, of Bloomington. These were all collected from plowed fields along Lost Creek and the neighboring stream valley of Rebecca Creek a few miles to the west (fig. 4). They pertain to the same general culture as house 1. The range of rim types from house 1 is indicated in table 5 (p. 248).

From the foregoing it is apparent that the majority (82 percent) of the pots used by the former inhabitants of house 1 were characterized by a marked collar between lip and rim and that the predominant rim design for incising consisted of parallel horizontal lines. Although the number of these lines varies in the present collection from 1 to 6 (1 sherd has 1 line, 4 have 2, 5 have 3, 10 have 4, 7 have 5, and 2 have 6 lines), it is obvious that the 4 and 5 line designs were the most popular. None of these lines on Lost Creek pots were made by cord impressions; they are all incised. Although this type of decoration occurs elsewhere rather commonly along Lost Creek and at other sites where this culture has been encountered, it seems to have been especially favored by the occupants of house 1 and house 2, since it overshadowed all other types. The other design units are all illustrated and do not need more description at this time. The method of decoration by means of small incisions across or along the lip (pl. 5, fig. 2, *d, j, k*) should be noted. This additional ornamentation is not confined to any particular type of rim but occurs sporadically on various types. It is also noteworthy that handles, lugs, tabs, or appendages of any sort are extremely rare in findings from houses of this type in the Lost Creek district. As previously mentioned, only one rim sherd suggests handles or tabs and these are too fragmentary for certainty. This sherd, unfortunately not figured, has no collar but has a straight

neck with the typical four parallel incisions around it. The three extensions occur at the bottom of the neck and are only a few centimeters apart, but have been broken off close to the body of the vessel. Whether they represent a series of tabs or are remnants of small handles cannot be determined. We will return to this pottery later in connection with that from other sites.

WORK IN GROUND STONE

The excavations in house 1 yielded three whole or restorable stone pipes (pl. 16, fig. 2, *g*, *k*, *p*) and one large bowl fragment. In addition, a fragment of a partially completed pipe was picked up on the surface of a plowed field not far from this site (pl. 16, fig. 2, *c*). All these pipes or fragments are cut out of white or red "pipestone". This mineral has not been accurately determined, but it is relatively soft and close-grained. No true catlinite pipes or fragments were found at this site.

The fragment last mentioned (pl. 16, fig. 2, *c*) is of red "pipestone" and was broken while being bored out. Evidently the maker shaped his pipe first and then drilled out the bowl. In this case he had drilled too far to one side and broken through the base. I have seen a Naskapi Indian, long out of practice, spoil two pipes in this manner prior to successfully completing one. The material in this Labrador incident was steatite. Probably this was a common accident in aboriginal pipe manufacture.

The pipe figured below it (pl. 16, fig. 2, *g*) is made of a whitish gray "pipestone" and comes from house 1. It is 45 mm high and 30 mm long at the base. The bowl measures 19 mm in diameter. It is hard to tell which end is bowl and which stem, as both are completely hollowed out and neither shows signs of fire. However, the longer section has the widest, deepest bowl and was probably so intended. There is no decoration on the pipe, which was complete when found.

The next pipe (pl. 16, fig. 2, *k*) is the largest and most elaborate found. It is restored from two pieces found separately in the east end of house 1. The material is a yellowish "pipestone". The pipe is 67 mm high, 44 mm long at the base, the diameter of the bowl is 29 mm and the stem 23 mm. The flaring rim and the graceful shape of the bowl are notable, as is the pointed end of the base. It was fitted with a large stem, to judge from the large hole at this end, which is only slightly smaller than the diameter of the bowl.

Another specimen (pl. 16, fig. 2, *p*) was complete when found except for a broken stem portion. It was found on the floor of house 1 and appears to be nearly complete. The material is red "pipestone",

and the pipe is 40 mm in height with a diameter of 21 mm for both bowl and stem. It is a well made, compact specimen with a projecting rounded point opposite the stem opening. The stem opening is again only slightly smaller than that of the bowl.

Only one other pipe fragment was found in house 1. This is the section of the bowl of what must have been a large pipe of white "pipestone". Around the rim are two notches, 23 mm apart, which may have been ownership marks or simple attempts at decoration. There is a slight curve at the bottom of this broken section, evidently indicating the beginning of the stem. Although great care was taken, no other pieces of this pipe were found during the excavation.

From the foregoing it appears that the elbow pipe bored from a soft stone was the predominant (and only) type found in house 1. It is also the most common form in local collections from the Lost Creek district. However, it should be noted that several pipes and pipe bowls of baked clay were recovered in house 2 which, in all other regards, was closely similar in its cultural content to house 1. The clay pipe, therefore, was also occasionally used by the Lost Creek people at this period.

In all, 16 shaft polishers of various shapes and sizes were recovered from house 1. All but two are of red Dakota sandstone, the two exceptions being of white sandstone. The largest (pl. 17, fig. 1, *d*) is 120 mm long, 41 mm wide, and 31 mm high, and has a shape suggesting the modern nail buffer. The profile of this type of shaft polisher (pl. 17, fig. 1, *f*) is best illustrated by a smaller lime-impregnated specimen also from house 1. The type is characterized by a single groove and the artifacts were probably used in pairs for smoothing down arrow shafts and similar wooden or bone objects.

The other specimens are smaller, and although the majority suggest the "nail buffer" type in outline, a few are square or rectangular in shape. The latter have from one to three polishing grooves, some of which are more worn than others. The smallest specimens are the most irregular and appear to have been used rather haphazardly.

Five hammerstones were found in house 1. One of these (pl. 17, fig. 1, *k*) is definitely worked and is a rather common type in Lost Creek sites. The material is a conglomerate of sand cemented with lime and of firm consistency. The two flat surfaces have been slightly hollowed out to fit the thumb and fore-fingers and the rounded edge has been used as a hammer. Both sides and edge show pitting, but the latter was apparently the main striking surface. It measures 90 mm in diameter, 54 mm in thickness, with a hollow on both sides of about 5 mm. Three of the other hammerstones are much cruder. They have

not been worked into shape but are merely large pebbles utilized as hammers. In shape they are roughly oval and the ends are pitted from blow fractures. One of these has one flat face which was used for grinding as well. The material of each is a sand and lime conglomerate, and they are rather heavily encrusted with lime. The fifth specimen has been roughly chipped from a quartzite boulder, and the top has been left rough. The bottom, however, has been used for both striking and grinding and has a very shallow, broad groove down the center. It measures 110 mm long by 84 mm wide and has a height of 60 mm. Its material and form rather suggest the quartzite side scraper found in historic and protohistoric Pawnee sites.

The occurrence of a few disintegrating nodules of lime-cemented sand should also be noted. These are grayish in appearance and may have been burned or treated in such a manner as to break them down. The sand that can be rubbed from them is very similar to the tempering used in the pottery and may have been so employed. Certain of these disintegrating nodules appear to have been used as grinding stones.

The striking paucity of ground stone artifacts in the Lost Creek sites is well indicated by the above slender list of types. Pipes, shaft polishers, and hammerstones conclude the list, which is meager indeed compared with the abundance and variety of chipped stone, bone, and antler artifacts.

WORK IN CHIPPED STONE

The excavation at house 1 yielded a large number and variety of chipped stone artifacts commonly worked from the local brown jasper, the latter occurring in the layers of limestone exposed by Lost Creek. Besides jasper, flint and chert were also employed. For the purpose of describing and comparing types of chipped arrowpoints, spear heads, and knives, a classification based entirely upon form rather than assumed function has been employed. The types are shown in outline (fig. 7) with the characteristics on which they are segregated somewhat exaggerated. These outlines are entirely irrespective of size. Although size is important in distinguishing between arrowpoints and the two other types of artifacts, it does not enter into the following classification, which is based entirely on form.

As each site is studied, the chipped points coming under the above classifications will be listed in table 3. In this way it is possible to see at a glance the distribution and grouping of types and to compare the various sites in this regard.

A large number of chipped stone arrowpoints were recovered in house 1. There were 32 in all, and these fall into six types: NBa (15),

NBa1 (3), NBa2 (3), NBa3 (1), NBc (9) and a doubtful broken example of SCa1 (1). Although these six specific types are present, the arrowpoints according to size as well as form fall into two main divisions: a small, delicately chipped NB type, usually with from two to five notches (NBa1-3) (pl. 7, fig. 1, *c*) and a larger heavy point of

CLASSIFICATION CHART FOR CHIPPED POINTS

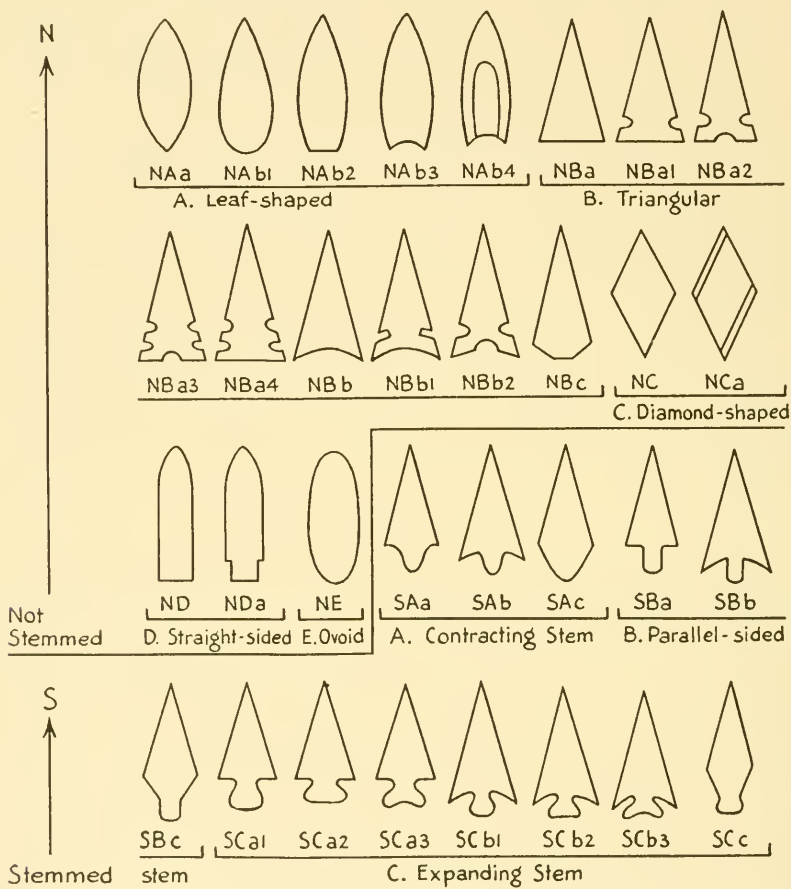

FIG. 7.—Form classification for chipped points (see table 2).

either NBa or NBc type (pl. 7, fig. 1, *j*, *m*). A typical specimen of the small, delicate type measures 25 mm in length and 15 mm in breadth at the base. A typical point of the second unnotched type is 46 mm long by 33 mm wide at the base. Since the two types each vary somewhat in size there is a certain amount of blending. However, the distinction is generally clear between the heavier, unnotched triangular

points and the very delicate triangular and often notched specimens. Apparently a difference in function is indicated here, a matter to be dealt with later. The distribution of the arrowpoint types from house 1 is also given in table 3. It may be added that the workmanship on the more delicate points is of a very high order. The majority of the

Table 2.—Classification Chart for Chipped Points⁶⁶

N. Not Stemmed	S. Stemmed
A. Leaf-shaped.	A. Contracting stem.
a. Pointed at both ends.	a. Shouldered only.
b. Pointed at one end.	b. Shouldered and barbed.
1. Convex base.	c. Neither shouldered nor barbed (lozenge).
2. Straight base.	B. Parallel-sided stem.
3. Concave base.	a. Shouldered only.
4. Concave base (longitudinal groove) [Folsom type].	b. Shouldered and barbed.
B. Triangular.	c. Neither shouldered nor barbed
a. Straight base.	C. Expanding stem.
1. Two side notches.	a. Shouldered only.
2. Two side notches and 1 base notch.	1. Convex base.
3. Four side notches and 1 base notch.	2. Straight base.
4. Four side notches and no base notch.	3. Concave base.
b. Concave base.	b. Shouldered and barbed.
1. Two side notches	1. Convex base.
2. Two side notches and 1 base notch.	2. Straight base.
c. Convex base.	3. Concave base.
C. Diamond shaped.	c. No barb, no shoulder.
a. Beveled.	
D. Straight sided and pointed at one end [Yuma type].	
a. Narrow base [Yuma type].	
E. Round or ovoid in outline.	

points are of clear brown jasper, but gray flint and chert is also employed.

The small end-scraper is very common in Lost Creek sites, and 20 specimens were obtained in house 1. Few artifacts have been given as many names as this widespread form—keeled, planoconvex, thumbnail,

⁶⁶ This classification, based upon that of Thomas Wilson, 1899, part I, pp. 887-944, was employed by Gifford and Schenck, 1926, pp. 80-81; by Schenck, 1926, p. 239, and Schenck and Dawson, 1929, pp. 370-371; and by Strong, Schenck, and Steward, 1930, pp. 78-79. It can be modified at will to suit special material.

TABLE 3—Distribution of Chipped Points According to Type

Sites	NAa	NAb1	NAb2	NAb3	NAb4	NBa	NBa1	NBa2	NBa3	NBa4	NBb1	NBb2	NBc	NC	NCA	ND	NDa	NE	SAA	SAB	SAC	SBA	SBB	SBC	SCa1	SCa2	SCa3	SCb1	SCb2	SCb3	SCc	Totals
Lost Creek, house 1	8	1				17	3	3	1				9	6	2			5							1(?)							56
Prairie Dog Creek ossuary	1					1	3	1	1						1			1													10	
Alma ossuary									2																						2	
Munson Creek ossuary								2																							3	
Rock Bluffs, house 2	3					10	2		1	1			5																		22	
Rock Bluffs, house 5						1							1																		4	
Gates site, house 1						2																									2	
Gates site, house 2						1	1																								3	
Elkhorn River, house 1						1				1																					2	
Walker Gilmore (deep strata) (Sterns)								1																							2	
Weeping Water Creek, mound 2																															2	
Dismal River, surface sites (A. T. Hill)																															2	
Signal Butte:																																
Upper layer	8	16	4			rare	yes	yes	1			32			5			39						rare								240
Middle layer	7	10																20							10		17				73	
Bottom layer	45	170	222				2	20										445							56	87	47	16	1110		1110	
Spring Creek (fossil bison) below Signal Butte (Schultz)																																4
Cumro (fossil bison) (Schultz)																																1
Grand Island (fossil bison) (Meserve and Schultz)					2																											2
Total number of points: 1556	12	60	109	226	2	113	64	37	4	2	1	32	0	16	6	9	1	522	0	0	0	0	0	0	4	68	87	1	20	50	10	1556

duckbill, and snub-nosed, to mention only the most common. The simple designation "end scraper" with qualifying adjectives for such details as size, however, seems preferable. In the present site all end scrapers are characterized by a smooth, flat ventral surface, often curved, owing to the plane of cleavage of the original flake, and a keel (or convex dorsal surface) culminating in an abrupt edge at one end and a gradual slant down on all other sides. In size the end scrapers from house 1 range from a length of 83 mm to only 27 mm. All of them are characterized by a much greater length than breadth. The following materials were employed: banded jasper 5, brown jasper 8, yellow jasper 2, chalcedony 2, flint or chert 3 (one of the latter is of "Nehawka flint" from southeastern Nebraska). The largest specimen from house 1 is 83 mm long and 35 mm wide (pl. 7, fig. 1, o). In addition to the clearly defined end scrapers are some six roughly sub-rectangular pieces of chipped flint, ranging from 50 mm to 37 mm in length and from 34 mm to 25 mm in breadth. These have been carelessly retouched on both sides and ends and in their flat ventral and ridged dorsal surfaces suggest the type of end scraper just described. They may be incomplete specimens or may be a cruder type. The end scraper was probably hafted and used in dressing hides and is often the most numerous single artifact on surface sites in Nebraska.

Three small flint or chert artifacts of ovoid shape may be tentatively classified as side scrapers. These specimens are very thin (6 mm for the thickest) and are retouched on both sides. Two of them are 44 mm long and the third is 22 mm long. The edges have received the most careful retouching, especially along the sides. They differ from the end scrapers in the latter regard as well as in lacking any keel or abruptly chipped end. In addition, there are 11 fragments of what appear to have been side scrapers, 5 ovoid and 6 circular in outline. Of these, 6 are retouched only on one side, the others on all sides. Four of these are red, black, and gray chert, 7 of yellow or brown jasper. The longest is 67 mm and the shortest 46 mm in length, and they range from 8 mm to 3 mm in thickness. It is obvious that all of the above specimens may have served as knives; however, the poorer workmanship and the emphasis on the side retouch at the expense of the whole blade favors their classification as scrapers. They have not been included in the chart (table 3) showing the distribution of arrow-points, spearheads, and knives.

A large number of thin, flat, delicately retouched stone artifacts from house 1 have been classified as knives. Including large fragments there are 50 pieces of this sort from house 1. These, with some

forcing, fall into six main types: oval in outline but having a point at each end (NAa), oval without points (NE), rectilinear in outline with one round and one straight end (NAb₂), triangular (NBa), diamond-shaped (NC), and diamond-shaped with beveled edges (NCa).

The first group (NAa) is subdivided into large and small blades. Of the former blades there are six large fragments made of various chert materials. Two of these fragments appear to be from the same specimen with only a small midsection missing. When these two fragments are put together and aligned in relation to their respective curves they produce a large blade measuring 144 by 75 mm. The other four fragments are of the same type, being characterized by their large size and beautiful retouching as well as by their thinness (pl. 7, fig. 2, *m, n*). The large size of these fragments is indicated by the range of their measurements, 123 to 145 mm in length, 78 to 53 mm in width, and 15 to 7 mm in thickness. The majority of the pieces are heavily encrusted with lime (pl. 7, fig. 2, *m*). They are the finest examples of large flint work from the site.

The smaller oval knife blades of this type number seven complete pieces and nine fragments. The seven complete pieces differ from the above in lacking bilateral symmetry. They are flattened along one edge as shown in plate 7, figure 2, *h*. The specimen illustrated is the best of the seven, some of which are rather crude and range from 85 to 18 mm in length, from 38 to 19 mm in width, and from 11 to 4 mm in thickness. The material is jasper in the majority of cases. As a rule the flattened side is the thickest and the most poorly chipped, and it is possible that a handle was fitted on this side. However, lacking any bone or other objects suggesting such handles, it is more probable that the blade itself was held here. The remaining nine well chipped fragments of jasper and chert appear to have been of the regular pointed oval type. Like the larger specimens of this type described above, they are heavily lime incrusted.

Of the second type, oval without points (NE), there are five complete specimens and twelve fragments. The specimen figured (pl. 7, fig. 2, *k*) is typical. It is 96 mm long by 45 mm wide, and the material is yellow jasper. The other four complete specimens are similar in size and shape; all are retouched on both faces and are very thin. So far as can be determined from their incomplete condition, the twelve broken fragments represent similar artifacts.

Only one specimen is rectilinear in outline with one round and one straight end. Hence it really represents a unique form rather than a distinct type. The material is black quartzite (?), and the arti-

fact is 95 mm long by 32 mm wide. The rounded end suggests the point of the blade, the other flattened end the butt.

The triangular type (NBa) is only slightly more numerous. There are only two knives of this form, one of which is illustrated (pl. 7, fig. 2, *j*). The latter is 105 mm long, 43 mm wide, and 11 mm thick and is rather roughly retouched. It is heavily incrustated with lime, as the illustration indicates. The second specimen is similar to the above but somewhat smaller (65 by 38 by 7 mm).

Diamond-shaped knives (NC) are more common, six coming from house 1. A typical specimen of jasper is figured (pl. 7, fig. 2, *d*). All these specimens are thin, and, with one exception, are biconvex. The one exception has one flat surface. The material of all is jasper, and they range in length from 114 to 66 mm and in width from 45 to 27 mm. One other specimen (pl. 7, fig. 2, *b*) is of this general type but has one end slightly rounded. Perhaps this was the hafted end.

The sixth and last type (NCa), that is, the diamond-shaped and beveled form, is poorly represented in house 1. One rather small specimen of yellow jasper has four beveled edges. Its dimensions are 62 by 38 by 6 mm. An unusual specimen with two notches above the point is likewise beveled and suggests this type (pl. 7, fig. 2, *e*). However, the larger part of the blade, on the other side of the notches from the complete point, is broken and it is uncertain what the original shape of the entire piece may have been. This is the only notched knife blade so far encountered in our excavation work.

Many pieces of heavy chipped stone work were found in house 1. In all, 80 artifacts roughly classified as axes, hoes, and picks were recovered. No polished stone celts or grooved axes were found. Practically all of these larger chipped stone artifacts were of yellow or brown jasper and were probably made from local material. The following classification according to function is open to some question but seems justified by the nature of the objects.

Forty-nine of these larger chipped artifacts appear to have been used as axes. These are of two types, a triangular form with a broad blade (35) and a more oval form with a less distinct blade (14). That they were used as axes is indicated by the battered and often retouched edge as well as by their form. Seven specimens have slight notches on one or both sides, suggesting that they were hafted. It is extremely probable that the majority had handles of wood. So mounted, they would make excellent chopping tools. Both the triangular (pl. 17, fig. 2, *k*) and the oval (pl. 17, fig. 2, *j*, *l*) axes are carefully worked and, unless battered from use, have keen cutting edges. Certain of the oval specimens in particular are beautifully retouched and of a perfect

"limande" form (pl. 17, fig. 2, *l*). In size they range from 174 to 50 mm in length, 78 to 42 mm in width, and 27 mm to 15 mm in thickness.

Sixteen specimens have been classified as hoes. These are long and thin and as a group show less severe usage on the broad or blade end (pl. 17, fig. 2, *m*). In size they approximate the larger axes but are more often rectilinear in outline than the latter. It is of course impossible to distinguish between hoes and axes in all cases. The presumption is that the former were lashed onto a bent or crotched stick as was the case with the shoulder-blade hoe so common throughout the Plains.

Only two specimens have been classified as picks. These are of rather rough workmanship and culminate in a point instead of a blade (pl. 17, fig. 2, *i*). The specimen illustrated measures 177 by 75 by 34 mm. The other artifact of this type is larger and heavier, measuring 120 mm in length and 75 mm in breadth. It is roughly retouched all over but is rounded on top, having a small and irregular point or pick. Whether either specimen was hafted is open to question.

WORK IN BONE

Lost Creek sites in general yield large quantities of bone work, and house I was no exception in this regard. Shoulder-blade hoes, mostly in fragments, and many smaller bone artifacts were recovered. One particularly excellent specimen of bison scapula hoe was found in the floor layer (pl. 6, fig. 2, *a*). This specimen, 25 cm long by 13 cm in width at the blade end, has a very sharp edge and was in thoroughly usable condition when left in the house. The spines had been ground down and a broad groove made over the top of the glenoid process for the attachment of a handle. Two large, evenly bored perforations had been made on the blade for a lashing across the tip of the handle. The groove across the top, as well as the perforations on the blade, suggest that the elbow of the handle may have fitted over the glenoid process and extended down over the face of the blade. Lashings across the tip of the handle and around the neck of handle and blade would have held it firmly in place. In historic specimens the handle is fitted and lashed under rather than over the bone blade. The edge of the specimen in question had been ground down to a place where further sharpening would have reached the tip of the handle. In cache 1 a large bison scapula was found in process of manufacture into a hoe. The spines had been ground down but the blade edge was unworked. In all, 25 fragments of what had evidently been scapula hoes were recovered. These show sharpened edges and in some cases perforations like those in the complete specimen previously described.

Six additional pieces of broken scapula hoes had been readapted to serve as hand scrapers and, in addition to a well-worked scraping edge, showed high patination along the other edges from long handling. The largest of these is 17.5 cm long by 6 cm wide and is characterized by one notch and by transverse scratches along the blade. Possibly it had been used as a knife or skinning tool.

Some 12 complete specimens and 13 fragments of bone awls or bodkins came from this site. For the most part these are beautifully worked and have delicate, very sharp points. They were probably employed in weaving mats and baskets as well as in the sewing of skins. No needles with eyes were found here. The common type of awl was split from the cannon bone of a deer's leg and ground to a stiletto-like point. The manner in which these awls were manufactured is shown (pl. 6, fig. 1, *n, o, p*). Three sections of deer cannon bone were found with the smaller end neatly cut off and the remaining bone tempered by fire (pl. 6, fig. 1, *p*). Also several split sections of similarly prepared bones were found (pl. 6, fig. 1, *o*). Of the tip ends of the bone thus removed four were noted in the excavations (pl. 6, fig. 1, *g*). A few of the awls are rounded and taper rapidly to a point (pl. 6, fig. 1, *k*). In length they run from 185 mm to about 60 mm. An unusual specimen of this sort is apparently made from the penis of a raccoon (pl. 6, fig. 1, *i*). It is neatly cut off at the base and worked to a slender point, resembling the meat forks made of similar bones employed by the Pawnee in historic times. Very similar rounded awls or bodkins were made of antler and are described under the heading of work in antler. The fragments of awls, like the complete specimens, are mostly tempered by fire and range in color from polished white to brown. One perfectly round specimen has a series of some ten small notches near the broken-off point. The notches form no definite pattern, and their purpose is obscure.

A large section of deer cannon bone with the joint forming the handle was also found. The opposite end is splintered to a decided point which is badly scarred from application to hard, sharp surfaces. Whether this artifact is a very crude awl or served as a stone-knapping tool is somewhat problematic. It is 120 mm long and 25 mm thick at the joint or handle end.

Another bone object of uncertain use suggests either a knapping tool, a wedge, or a chisel. It is of heavy bone, tempered by fire and of an ivory yellow color. The butt end is large and smooth, and the blade tapers to a rounded point. On one side a heavy splinter of bone has been split out from the point as though the tool had been hammered against something with too great force. The butt end, however, shows

little sign of long-continued hammering. The specimen is 103 mm long, 40 mm wide at the butt, and 10 mm wide at the point.

Three bone fishhooks and one unfinished part of a similar artifact were recovered (pl. 9, fig. 2, *a-d*). The largest specimen (pl. 9, fig. 2, *d*) is 45 mm in length and 5 mm in thickness. Around the top of the shank is a shallow groove for the attachment of a line. This hook is heavily incrustated with lime and is rather thick and clumsy looking. The other complete specimen (pl. 9, fig. 2, *b*) is much more delicate with a slender point, curve, and more delicate shank. It is 35 mm in length and has a groove around the top of the rounded shank. It has been tempered by heating. The third specimen (pl. 9, fig. 2, *c*) has a broad bend and needle-sharp point, but the end of the shank has been broken off at the line groove. It is 40 mm long and about 3 mm thick. All three fishhooks are without barbs. From the broken and unfinished specimen it seems probable that the hooks were made in pairs from a flat piece of bone with the center gouged out (pl. 9, fig. 2, *a*). The same technique was employed in the manufacture of the ancient Iroquois fishhooks. (Compare Skinner, 1921, fig. 3, p. 71.)

Two hollow, slightly curved tubes of bird bone were found lying together on the floor of house 1 (pl. 11, fig. 2, *j*). The larger is 122 mm and the smaller 115 mm in length and both are 9 mm in diameter. Aside from having the ends neatly cut off they are unworked. They may have been used as part of a breast ornament or gorget. It is also possible that they represent sucking tubes and were part of a ceremonial outfit.

Five bone beads and one piece of bone from which beads had been cut were also found. The beads are of bird bone, and all but one have been heat-tempered. They range from 50 mm to 14 mm in length, and in each case they have been neatly cut at both ends (pl. 11, fig. 2, *i*). In addition there was found the wing bone of a bird (possibly a prairie chicken) which had been fire-tempered and from which beads had been cut. The bone is 60 mm in length and on the end opposite the joint is one bead 10 mm long not quite cut away from the remainder of the bone.

Two pendants were found. The first of these is the canine tooth of a wolf with a neat hole for suspension bored through the tip of the root (pl. 9, fig. 2, *h*). This specimen was found on the floor of house 1. The other pendant is of bone, coated with a deposit of lime (pl. 9, fig. 2, *k*). It is slightly curved, has a rounded upper end with a neat hole bored through, and the tip is broken off. The specimen is 45 mm long, 9 mm wide at the large end, 5 mm wide at the broken tip, and

averages about 2 mm in thickness. It is closely similar to artifacts of shell from ossuaries of the same culture (pl. 9, fig. 2, *i, j, l, m, n*).

A variety of partially worked or of broken bone fragments were found, but most of these are too fragmentary to merit detailed description. However, one flat piece of worked bone, 78 mm long by 15 mm wide, has been heat-tempered and well polished by use. It has rounded edges and is larger at the ends than in the middle, suggesting some sort of a handle, although its method of attachment or of use is obscure. A small worked piece of bone suggesting the tooth of a comb may be worth mentioning. This piece is triangular in outline, being 30 mm long, 5 mm wide at base, and 1 mm thick. It has a polish on both sides resulting from use. No other artifact suggesting a comb was noted. Several solid and perfectly round sections of cut bone, often with deep notches in them, were also found. These fragments are similar in size to the round awls and may have been reworked fragments.

BONE OR ANTLER BRACELET FRAGMENTS

In cache 1 were found two small fragments of a delicate incised bracelet or arm band. Several other fragments of similar nature were also found by Ralph Douglas in the west refuse heap of house 1. The fragments from cache 1 are extremely thin and have been burned to a whitish gray, shell-like consistency. It is impossible to tell whether they are of antler or bone. The largest is 50 mm in length, 25 mm in breadth, and less than 2 mm in thickness. On the convex surface is an incised design of two vertical lines about 35 mm apart with eight horizontal connecting lines. The other fragment is 35 mm long, 20 mm wide, and the same thickness as the other. It has been rounded at the corners of one end, which is the end of the specimen itself. Five millimeters from the end is a vertical line with eight horizontal lines running to the broken ends of the fragment. In each corner of the design is a round perforation apparently for the attachment of thongs. The two fragments suggest a round arm band with units of design made up of two vertical and eight horizontal lines. The bracelet apparently went part way around the forearm and was tied together by two thongs. Whether there was more to the design than is indicated, or how many design units there were, is indeterminable, owing to its fragmentary condition. Careful sifting of the refuse material in the cache pit yielded no other fragments.

WORK IN ANTLER

Work in antler is rather abundant among the artifacts from house 1. The animal species represented most commonly are the elk (*wapiti*)

and the deer. Certain artifacts, such as awls and bodkins, are very similar to those made from bone, and their segregation according to material used is more or less artificial.

One long, perfectly round awl of ground-down antler is 154 mm long by 7 mm in diameter (pl. 6, fig. 1, *h*). A smaller bodkin (pl. 6, fig. 1, *j*) is 85 mm long by about 8 mm in diameter. Both are perfectly round in cross-section and have delicately tapering sharp points. The shorter specimen is complete, but the longer awl appears to be broken off at the butt end. The latter is also characterized by a gradual outward curve toward the point, whereas the shorter artifact is perfectly straight.

In addition to the above well-worked specimens are three antler tips of either small elk or large deer. They have been cut off at the base but are otherwise unworked. In one case this cutting is very neatly done and the slender tine has clearly been used as a tool of some sort. In the other two specimens the cutting is very rough and they show but little sign of use. The longest and best worked of these is 215 mm in length with a diameter of 26 mm at the base (pl. 18, fig. 1, *d*).

There are also three cylindrical sections of deer antler, two of which appear to have been used in flint working. In all three cases the base of the antler has been preserved, and a neat cut has been made at the other end. The longest of these artifacts is 180 mm with a diameter of 33 mm at the large end (pl. 6, fig. 1, *e*). The surface is rough, natural antler, but one small tine has been cut off the side. One end of this artifact has the swelling characteristic of the base of the antler, and the opposite end has been neatly cut off. In the cut-off end is a funnel-shaped cavity about 13 mm deep. This cavity, in conjunction with the rather extreme curve of the implement, suggests that this particular specimen may represent a handle of some sort rather than a tapping tool. Two somewhat similar specimens from prehistoric earth lodges near Omaha are in the Gilder collection in the Omaha Public Library, one (303 h) serving as the handle for an end scraper, the other (278) for a small stone knife. It is said that these artifacts were found so mounted in situ. It may be that we have here a similar handle, although it should be noted that in the two Gilder specimens, as well as in the present implement, the holes for mounting are extremely shallow. The main evidence for each use rests on the reported finding in situ of the combined specimens.

The two remaining artifacts of this sort from house 1 are straighter and show no sign of having been employed as handles. The specimen figured (pl. 6, fig. 1, *d*) is 120 mm in length by 25 mm in diameter. The utensil has been rubbed smooth and the rough original surface of

the antler removed. The top, or large end, has been smoothed off and shows considerable pitting from hammering. The splitting observable in this illustration is apparently due to the imperfect preservation of the artifact. A similar specimen is 130 mm long by 35 mm in diameter, the large end being formed by the base of the antler, as is the case in the other similar artifacts, and the smaller end has been neatly cut off. The grip has been left rough in contour like the original antler. The function of these last two artifacts would appear to have been that of punches used with a hammerstone for striking off large flakes of workable stone material.⁶⁷

One antler shaft straightener was found in cache 1 (pl. 6, fig. 1, *b*). It is made from a tine of deer or elk antler which has been perforated and smoothed. The specimen is 130 mm long by 17 mm wide, with the hole 26 mm by 17 mm in length and width. The hole is notched from use on all four edges and a wooden shaft, such as a lead pencil, run diagonally through the hole fits neatly in the transverse groove thus formed. In other words the originally round hole has evidently been worn down on the ends by the transverse pressure of wooden shafts. There is no similar wear on the sides of the hole, and the artifact was apparently held in a vertical position when in use. Particularly interesting are four ownership or decorative marks arranged in pairs on the large end above the shaft hole. Both ends of the antler are broken, and the artifact had evidently been discarded by its former owner. Such artifacts were used in lining up and straightening arrow shafts when newly made or after use when warping had occurred.⁶⁸

One antler artifact from house 1 suggests a wedge or chisel (pl. 6, fig. 1, *a*). It has seen hard service and is marked by narrow grooves along the flattened blade. It measures 165 mm in length and is 30 mm wide at the butt, which is broken, and 15 mm wide just above the point. It is made from a single tine of elk antler.

The finding of several roughly worked antler tips, perhaps used as awls, has already been referred to. In addition, a flat strip of elk horn was found which measured 181 mm by 35 mm. It was rough and of natural antler ridging on the outer surface but smooth and somewhat hollowed out on the inner side. This slightly troughlike shape was due

⁶⁷ For the actual use of such an artifact see Saxton Pope's account of Yahi archery, 1918, p. 116 and pl. 27.

⁶⁸ That this type of artifact was actually used for the purpose suggested is attested by both ethnological and archeological records. Birket-Smith, 1929, p. 360, gives references for its use in many areas of both North America and northern Asia. I have actually seen it used by old Dakota Indians on the Standing Rock Reservation.

either to purposive removal or the rotting out of the softer core material. Down each side was a smooth edge where the slab had been removed by grooving down both sides and prying or splitting off the horn. There are several rough cuts along one edge. This might be an antler bracelet or other ornament prior to the working down and steaming processes. Fragments of bone or antler bracelets of this type from cache 1 have already been referred to.

WORK IN SHELL

Very little worked shell was found in house 1. One flat shell bead (pl. 11, fig. 2, *d*) about 15 mm in diameter with a hole 5 mm across and a thickness of 2 mm was the only artifact of this type encountered. It was ground from the shell of a fresh-water bivalve and retains considerable luster. One worked shell (*Uniomorus tetralasmus* Say) was noted with one edge serrated for a distance of about 40 mm. Other unworked bivalve shells found in caches and on the floor were in all probability used as spoons.

No work in copper, nor any indications of basketry or textile work, were encountered. Cordage was indicated only by the cord-marked pottery. The lack of certain perishable materials naturally does not indicate their absence from the culture here represented. The site presented no unusual circumstances for preservation of perishable materials, and as a result this type of artifact had vanished.

ANIMAL AND MOLLUSCAN REMAINS

Owing to the lack of comparative material at the University of Nebraska, it was impossible to obtain a complete list of the fauna represented at the Lost Creek site. However, certain animal forms were easily identified and in some cases it was possible to check the animal remains against known material. The most abundant remains were those of the bison. Broken marrow bones of this species were fairly common as well as skull fragments and teeth. No complete skulls, horn cases, or horn cores were noted. Wapiti and deer (white tail and possibly mule deer) bones and antlers were almost equally numerous. Remains of the antelope were also found. One fragment of a dog's skull and a perforated canine of a wolf or large coyote were noted. Without sufficient comparative material it is impossible to positively distinguish between these three species. Several beaver teeth, raccoon and rabbit (both jack rabbit and cottontail) bones, and a large number of rodent bones were also noted. The prairie dog was the most common species among the latter remains, but it was impossible to

identify others. All the bone material from the site was checked over by graduate students in paleontology, but no horse remains were present. Many bird bones were found, but aside from noting a preponderance of those from geese, ducks, and probably prairie chickens, no detailed comparisons were made.

Owing to the nature of the site, no vegetal remains of any sort were recovered in our excavation work. The abundance of bone and stone hoes, however, testified to horticultural pursuits.

Considering the fact that Mollusca are rarely seen nowadays in the Republican River, a surprising number of species were recovered from house 1. Their identification, as previously mentioned, we owe to Dr. Frank C. Baker, of the University of Illinois. With one exception these are all fresh-water species. The exception is the species *Olivella jaspidea* (Gmelin), which is a marine shell from the Atlantic or Gulf coast. A considerable number of these in an unworked condition were found in cache 1. The fresh-water forms found in house 1 are as follows:

- Lampsilis anodontoides* (Lea)
- Quadrula quadrula bullocki* (F. C. Baker)
- Quadrula postulosa prasina* (Conrad)
- Tritogenia tuberculata* (Barnes)
- Unio merus tetralasmus* (Say)
- Anodonta grandis* (Say)
- Anodontoides ferussacianus subcylindraccus* (Lea)
- Proptera alata megaptera* (Rafinesque)
- Sphaerium silicatum* (Lam.). Numerous
- Physa gyrina* (Say). Numerous
- Helisoma trivolvis* (Say)
- Helisoma pseudotrivolvis* (F. C. Baker). Numerous
- Anculosa praerosa* (Say). Great number in cache 1

This last species of fresh-water snail is common in the Ohio and Wabash Rivers but is not believed to occur west of Illinois. Dr. Baker suggests it was obtained by barter from Illinois tribes.

HOUSE 2

An area southeast of house 1 was dug up by local collectors a year or so previous to our own excavations, and it was this earlier work that called the site to our attention. I have designated this as house 2, for although very little could be learned in detail as to the nature of the internal structure revealed by the earlier digging, there is no doubt that it was a house site very similar to ours. Through his own efforts and by gift or purchase, Karl L. Spence had gathered together a large part of the material from this site. In October 1931 he very kindly

sent me photographs and notes on this collection which is similar to that obtained from house 1. The one complete pot from house 2 has been previously described. The rim sherds from house 2 are closely similar to those from house 1. The collared rim with incised decoration is exceedingly common and the use of a varying number of horizontal lines predominates as a decorative motif. Incisions on the lips of the vessels occur, and diamond-shaped or closely crosshatched incised rim designs are common. Incised triangles occur and in some cases these triangles are filled with horizontal lines. A great majority of the sherds illustrated in Mr. Spence's photographs are cord-marked on the body, and there are no indications of either lugs or handles. Sherds with notched rims also occur in some cases. On the whole one might say that the ceramic remains from both houses are in all essentials identical.

The pipes, whole and fragmentary, from house 2 are exceptionally interesting. The finest of these is illustrated (pl. 21, fig. 1, *c*). It is made of hard stone and, when found, was heavily impregnated with lime. Removing the lime, Mr. Spence found the design which represents the head of a catfish with great realism. A very similar pipe had been pecked out, but after attempts to drill it at bowl and stem it had been abandoned. Two broken fragments of stone pipes are very similar to those figured from house 1 (pl. 16, fig. 2, *c, g, p*). In addition, five pipes or fragments of pipes made of clay were recovered. Two of these are closely similar in shape to the stone pipes from house 1. Of the others, one small pipe bowl decorated by horizontally depressed rings and a larger, almost round specimen are noteworthy. Mr. Spence says that these specimens are molded and are not drilled. The material has evidently been fired with varying degrees of success in the different specimens. The occurrence of clay pipes in house 2 is one of the few marked differences to be noted between that site and house 1. Since the other artifacts from the two houses are so very similar, it is probable that the lack of clay pipes in house 1 is accidental rather than significant.

Aside from rounded, cylindrical hammerstones and shaft polishers, no other polished stone implements are recorded from house 2. Mr. Spence notes specifically that no polished or grooved celts or axes were found. The work in chipped stone is closely similar to that described from house 1, and practically all the types referred to there were found in house 2. The flint knives are similar to those from house 1 except that the large laurel-leaf blades are not mentioned, whereas the diamond-shaped, beveled knife (Harahey type) was very abundant. Of about 50 specimens of this type of knife found by the earlier workers

in the vicinity of Lost Creek, the majority came from house 2, according to Mr. Spence. The bone implements are likewise very similar to those from house 1. Two crude "picks" of almost unworked bison ulna (pl. 21, fig. 1, *d*) are interesting, since similar crude artifacts are common in historic Pawnee sites. A fragment of bone or antler shaft straightener with notches along one surface is also a new type. One broken bone fishhook was found in house 2. Mr. Spence notes the fact that in all the work carried on at this site no glass, metal, or other Caucasian artifacts were found. This is in accord with our findings in house 1.

DISPOSAL OF THE DEAD

In spite of much searching by local archeologists and by our own party, no burials pertaining to the prehistoric people of Lost Creek have come to light. One intrusive burial was dug up by local men in the refuse deposits along Lost Creek a short distance north of house 1. The artifacts with the skeleton, however, were in large part of Caucasian origin and bore no relationship to the earlier culture. Our party did considerable prospecting and trenching on likely points and hills, with entirely negative results. From evidence shortly to be given it appears certain that when these earlier burial places on Lost Creek are located, they will be in the nature of ossuary pits on the higher hills or points along the river or creek.

OSSUARY ON PRAIRIE DOG CREEK, HARLAN COUNTY

Since our efforts to discover the burial places of the Lost Creek people were unavailing, we transferred our activities to a site on the Robert Graham farm across the Republican River from Republican City (fig. 1, site 14, fig. 8, site 1). This site in Harlan County is about 20 miles west of the Dooley farm on the same or south side of the river. Earlier work here by C. B. Schultz, of Red Cloud, Nebr., had revealed human bone mingled with pottery of a type suggesting that from Lost Creek. Mr. Schultz kindly showed me the site in November 1929, and thanks to the permission of Robert Graham, the owner, we were able to work here from July 26 to August 4, 1930.

The burial site in question was located on the summit of a rolling hill about $1\frac{3}{4}$ miles south of the Republican River and a short distance south of Prairie Dog Creek, which enters the river just northeast of this point (see fig. 8, and pl. 8, figs. 1, 2). The site has an altitude of some 2100 feet and with other hills to the east and west forms a line of bluffs bordering the river valley that is rather striking in

the flat prairie country. Between the hill and the river are flat bottoms now largely under cultivation. A branch of Prairie Dog Creek encircles the hill to the west and the main creek flows by in a northeasterly direction at its base. The course of the streams and the river is rather heavily wooded, but the hills are entirely bald. Because of the tall corn it was impossible in a limited time to make a survey of the upper bottom lands along the creek, but a careful search would probably reveal clear traces of houses. Some sherds, shells, and flint artifacts were found in the cornfields just below the hill in question

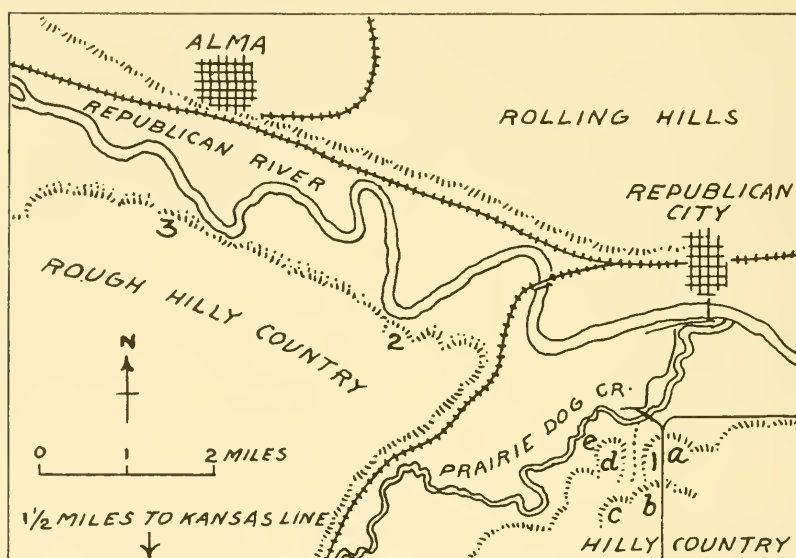

FIG. 8.—Sketch map of Prairie Dog Creek District. 1, Graham site; *a-e*, other excavations; 2, Marshall site; 3, Alma ossuary.

(pl. 8, fig. 1), marking the location of one village which could not be worked because of the ripening corn. The next hill to the west is slightly higher than the one we designated as Graham Hill and is locally known as Indian Hill because of the human bones and artifacts dug up on its summit in times past (pl. 8, fig. 2). These hills are the most striking features of the entire landscape, and human figures on their summits are visible for many miles in every direction.

Excavation on the summit of Graham Hill indicated that the human bone and artifacts were concentrated in an area 24 feet long by 23 feet wide (fig. 9). The whole central portion of this area had been dug over by previous visitors, but these earlier diggings had only reached the bottom of the deposit in a few places and had not extended to its

borders. Within this area was a mixture of broken and scattered human bones, broken pottery, artifacts, intrusive rocks of various sizes, and a little charcoal and cultural debris. The original pit was about 3 feet 6 inches deep in the center, sloping gradually upward on all sides so that around the edges the human deposit extended to a depth of only 12 to 14 inches (fig. 10). Trenches run beyond the 24 by 23

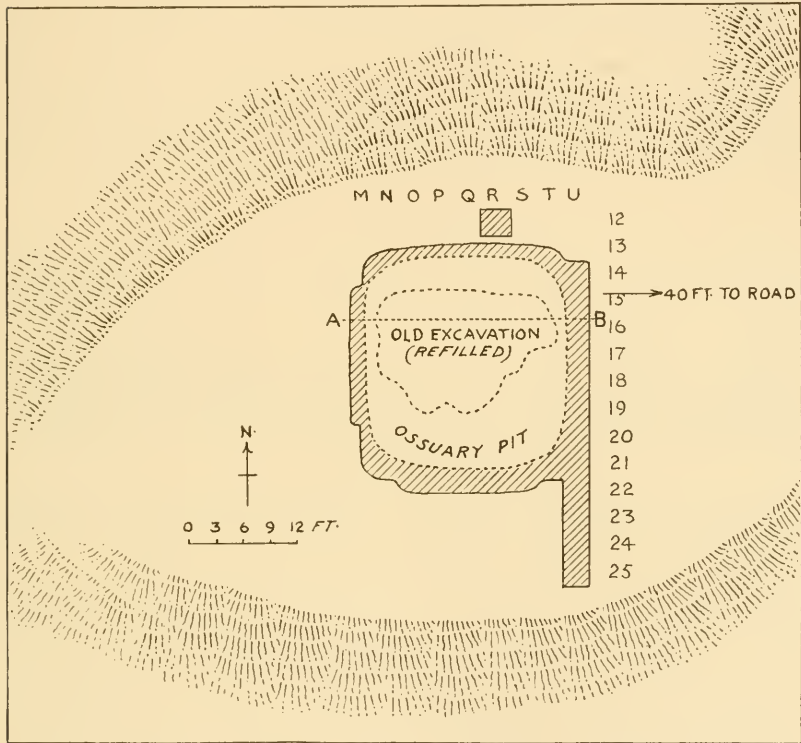

FIG. 9.—Ground plan of Graham site. Hachures, excavated area outside ossuary pit; extent of ossuary and of former excavated area indicated by dotted lines. A-B, cross-section shown in figure 10.

foot area were barren except for a few potsherds or flint fragments in the upper 12 inches near the main pit itself. The earlier digging had so disturbed the central part of the pit that it was impossible to determine accurately the methods by which it had originally been dug and then refilled. It appeared most probable, however, that human remains and artifacts had been thrown in and covered up over a considerable period. As the cultural remains indicate, the bulk of the material here was homogeneous, although it is possible that some

intrusive deposits may have occurred. The natural soil itself was a gray sandy loam with considerable lime or magnesium at a depth of 3 feet or more. It was extremely hard except that within the pit itself there had been a great deal of badger and smaller rodent work which made softer areas. The recent digging was for the most part easily distinguished except where it had been taken advantage of by rodents in enlarging their runways. There is, however, no reason to believe that rodents or recent workers were responsible for the broken and haphazard arrangement of bones and artifacts, for this was equally apparent in places where there was no trace of any such disturbance. Our own excavation work covered the entire interment area and extended beyond into barren soil on all sides. The work was carried on by a series of trenches all of which were carried down

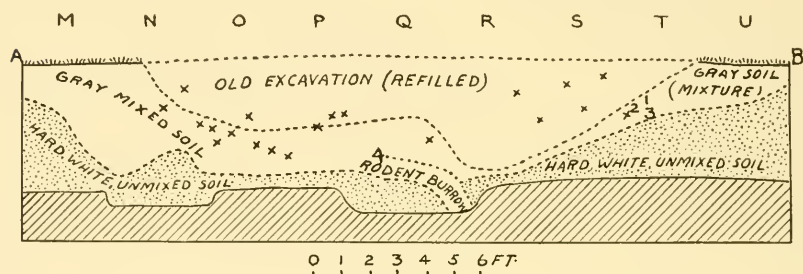

FIG. 10.—Cross-section of Graham site. 1, carved antler bracelet; 2, fragment of male skull; 3, pocket of 12 shell beads; 4, sandstone shaft polisher; X, indicates fragments of human bone; hachures indicate unexcavated soil.

into the undisturbed natural soil. Definite concentrations of bones and artifacts within the pit were not observed, material of this sort being scattered through the entire area from top to bottom (pl. 8, figs. 3, 4).

With the exception of two infant skeletons, there was no indication of any order in the human remains. Bones and bone fragments were scattered throughout the pit area without any indication of natural association. The first child's burial was found at a depth of 2 feet in the east-central part of the pit. The crushed skull and most of the other bones were present but badly disintegrated. Near the neck were a number of perforated marine shells (*Olivella jaspidea* Gmelin) and snail shells (*Anculosa praerosa* Say), probably part of a necklace. There was no indication of a definite laying out of the remains nor of any separate grave. Rather the remains appear to have been thrown in with the surrounding human bone fragments. The second infant skeleton occurred at a depth of 12 inches in the northeast corner of the burial pit. In spite of the shallow earth

covering, the skull was completely smashed. The ribs, vertebrae, and some of the long bones were present. As in the preceding case, this skeleton had been put into the general pit, no indication of individual burial or of grave gifts being present. One fragment of a child's calvarium was found at a depth of 4 feet, about 7 feet west of the skeleton just described. It had been carried down a large rodent burrow and may originally have been with the near-by infant remains.

As previously stated, no adult human remains were found in definite association. The skull of an adult male was found at a depth of 3 feet in the central part of the pit. The completely inverted position of the skull *in situ* is clearly indicated in the illustration (pl. 8, fig. 4). Near this skull were found three human mandibles in a good state of preservation. In the northwest corner of the pit at a depth of 14 inches was an adult female skull likewise in a good state of preservation. Three fragmentary adult skulls were also encountered at depths of 8, 10, and 12 inches, respectively. Besides these skeletal remains, human bones of every sort were found at all depths throughout the pit area. The random distribution of these bones is clearly indicated by the diagram and photographs (fig. 10 and pl. 8, figs. 3, 4). All the projections shown in the photograph of the trench wall (pl. 8, fig. 3) are human bones as they occurred *in situ* in a hitherto undisturbed section of the pit. In all, two large boxes were filled with these skeletal remains. It is significant that many of the bones were more or less slightly scorched or charred. None, however, were completely burned. There was no evidence that these had been burned *in situ*; rather they appeared to have been scorched (perhaps by prairie fires) at a time prior to their disposal in the pit.

Owing to lack of adequate laboratory space and anthropometric instruments, no detailed study of these remains was attempted, but they are preserved in the Nebraska State Museum for future reference.

Disregarding for the moment the artifacts associated with the human remains, there were few other features worthy of comment. It should be noted, however, that a considerable number of rocks of varying sizes were scattered throughout the pit. These are not natural in this hilltop soil and were obviously placed in the pit by human agency. Their purpose is unknown. Charcoal occurred in small fragments throughout the pit area. There was no concentration of charcoal and ash nor any fireplaces, and it would appear that the charcoal was more or less accidentally mixed with the earth used to cover the bones. The same explanation probably holds for the few animal bones (other than rodent) occasionally found in the pit. Like the charcoal, these

remains are too scarce to indicate actual occupation of the site and appear to have been brought in either with the human bones or with the covering soil.

POTTERY FROM GRAHAM OSSUARY

Ceramic remains from this site were abundant and extremely interesting. The following list indicates the amount and major types recovered:

- Complete pots, none.
- Restored pots, none.
- Total number of sherds, 923 (rim 113, body 810).
- Cord-marked sherds, 866 (rim 83, body 783).
- Plain ware sherds, 57 (rim 30, body 27).
- Incised body sherds, none.
- Hematite stained or painted, none.

The description of paste, color, and tempering in the sherds from house 1 on Lost Creek is entirely applicable to the above collection, and hence need not be repeated. Although the color of the above sherds is predominantly gray, there are perhaps more approaching a clear brown or buff than there are from house 1. The great predominance of cord marking (94 percent) and the complete lack of handles or lugs both serve to bring out the relationship between the two wares. Only one sherd from the Graham ossuary gives evidence as to the shape of the bottom of the pot, and this is rounded. Many of the plainer sherds are blackened from use, whereas the most decorated pieces are often without any blackening or charring. Two heavy cord-marked sherds are interesting on account of neat holes bored through from the outside. It seems probable that the holes were for lashings to mend breaks, although it is possible that some other purpose, such as the making of potsherd disks or beads, is indicated. These two sherds, respectively 7 and 8 mm thick, are of the thickest ware observed and contrast markedly with three unusually delicate sherds which average 4 mm in thickness. The latter have exceptionally fine cord markings and are dark gray on the outside and reddish brown on their inner surface. The hematite-stained ware, rare in house 1, was not observed in the present site.

The sherds from the Graham ossuary (pl. 9, fig. 1), like those previously described from house 1 on Lost Creek, have the great majority of their decorative elements on shoulder and rim. The range of rim types from the Graham ossuary is indicated in table 5 (p. 248).

Incised designs on the lip of rim sherds are rather common and occur on examples of most of the above types, with certain exceptions noted in the above list. A series of small angles running

around the lip, transverse double and single lines, recurring dots and short lines are all employed. This form of lip decoration occurs in about 32 cases. Another feature is the rather common occurrence of narrow extensions between notches on the lower edge of the collar of a definite nipplelike form (pl. 9, fig. 1, *d*). The collar or shoulder between lip and lower rim occurs in slightly less than 50 percent of the cases.

A comparison of table 5 and plate 9, figure 1, with plate 5 will show the close resemblance between the present ossuary pottery and that from Lost Creek sites. The similarity is obvious, the most marked differences being the greater abundance of collared rims (82 percent) in house 1, Lost Creek, compared with the same type in the Graham ossuary pottery (less than 50 percent) and the much greater abundance of horizontal line decoration at the former site. Such differences would be expected in different sites of the same general culture and might also be due in part to the fact that the finds represent slightly different periods.

WORK IN GROUND STONE

Only one pipe was found in the ossuary in question. This was a much weathered and eroded specimen of white "pipestone" similar to those from house 1, Lost Creek. It is an elbow pipe, 37 mm high from bowl to base and 20 mm in diameter at both bowl and stem (pl. 16, fig. 2, *n*). The interior of the bowl forms an oval, whereas the stem cavity, only slightly smaller, is triangular. The extreme weathering of the pipe is apparently due to exposure before it was placed in the ossuary pit.

In all, four broken sandstone shaft polishers come from the Graham ossuary. They are all of the "nail buffer" type (see pl. 17, fig. 1, *f*, for type) and range from 90 to 40 mm in length. One specimen has a well-defined double groove on the base, one channel continuing up over the top of the artifact.

One piece of hard red stone, polished smooth and flat on both sides, seems to have been used either for grinding or polishing. It is slightly incrustated with lime and is 90 mm long by 50 mm wide.

WORK IN CHIPPED STONE

Seven small chipped arrowpoints were found. Of these, three were of jasper and the remainder of chalcedony and chert. The majority (five) are notched, one is unnotched, and one crude specimen suggests a stem. All are of the delicate, thin type noted in house 1, Lost Creek, and range in length from 35 to 21 mm. Six fall into the NBa group

(pl. 7, fig. 1, *d*), the seventh, which is the crudest and may be aberrant, suggesting the SCa1 type (pl. 7, fig. 1, *a*). The exact classification of these points is shown in table 3.

Two small, neatly made end scrapers of brown jasper were found here (see pl. 7, fig. 1, *g*, for type). One specimen is 40 mm long, 22 mm broad, and 5 mm thick. It is the usual planoconvex type neatly retouched on all edges. In addition, two worked stone pieces, respectively 23 and 20 mm in length, suggest this type of artifact but are very crudely retouched on all sides. There are two other oval fragments of roughly chipped stone which may belong to either this or the following type.

No well-defined side scrapers were found in the ossuary. There are two fragments of chert, however, which are retouched on only one side and may have been used as side scrapers.

One good example of the diamond-shaped beveled knife, often called the "Harahey" type, was found in the Graham ossuary (pl. 7, fig. 2, *c*). The specimen, of brown jasper, is 125 mm by 48 mm in greatest dimensions and is very thin. The four edges are neatly chipped and beveled. When found, the knife was broken, but the two pieces were in close proximity to one another. Four other knife fragments were found; one was pointed and one rounded at the tip, and the other two were rectangular fragments of uncertain form. All four are of brown jasper. The three adequate specimens are classified in table 3.

WORK IN BONE

One bone shaft straightener came from the south side of the ossuary pit at a depth of 3 feet. It is made from the rib of a large animal, probably a bison, and has a neatly cut and much worn oval hole in the center (pl. 6, fig. 1, *c*). One end is cut off, the other broken, the entire specimen being 13 mm long. This artifact is notable since similar rib bone shaft straighteners are common in historic and protohistoric Pawnee sites.

One extremely well-finished bone awl was found at a depth of 2 feet 6 inches in the north-central part of the pit. The artifact has a rounded butt, is well polished, and has a slender sharp point (pl. 6, fig. 1, *l*). The butt formed by the head of the bone has the beginning of a small bored hole on one side as though an eye had been started. The awl is 180 mm long.

Only two small bone beads were found in this site. Both have been carefully cut from the hollow bone of some medium-sized bird. One is 8 mm and the other 7 mm in length. The type is illustrated

by similar specimens from house 1, Lost Creek (pl. 11, fig. 2, *i*). One small pendant, the material of which may be bone, is described later with other similar objects made from shell.

WORK IN ANTLER

In the northeast portion of the ossuary pit at a depth of 8 inches an unusually interesting bracelet or bow guard was uncovered (pl. 10, fig 4). It had been broken into 32 pieces by long continued pressure, but being almost complete, it was fitted together in the field by Mrs. Strong. The specimen is decorated with a rather elaborate design (pl. 10, fig 2). The material appears to be antler, probably elk, split along the grain and then steamed and bent into a circle. Its length, if laid out flat, would be 170 mm, and its width is 55 mm; it has three neatly bored holes in each end for the attachment of thongs to go around the arm. The outer surface is smoothly polished, whereas the inner surface shows the natural grain of the material. The incised design consists of an outspread hand at either end reaching along the bracelet, the wrist of each hand is decorated with four angular lines probably representing bracelets, there is a circle on the center of each hand, and the nails of each finger are clearly indicated. Around the greater curve of the object are six double lines, each cross-hatched at 8-mm intervals. Each of these double lines culminates in a point and reaches just within the fingers on both ends. The object is well preserved and shows no sign of having been burned. In size it comfortably fits the forearm of a grown man just above the wrist, and since the material when fresh must have had considerable strength, it may have served to protect the forearm from the twang of a bow-string. Its rather elaborate decoration, however, suggests a bracelet of purely ornamental character. The significance of the design and its nearest analogies in prehistoric American art will be discussed later. There can be no doubt, however, that the present artifact is closely similar to the calcined bracelet fragments recovered from house 1, Lost Creek.

WORK IN SHELL

Two long pendants or ear ornaments found separately in the Graham ossuary pit are exceptionally interesting (pl. 11, fig. 1, *c*). These are cut from one shell of a large Gulf coast conch (*Busycon perversus* Linn.) which is native to the coast of Florida and the Gulf coast generally. When the two objects are placed side by side, they fit perfectly and show clearly where they have been cut apart. Each has been neatly cut off and ground on both ends, and each has a neat

3-mm hole bored through the broad end. In size they are practically identical, with a length of 120 mm, a greatest width of 21.5 mm, and a minimum width of 9 mm. The shell itself is 5 mm in thickness in the heaviest part. The texture of the shell is smooth, having a dull, chalky white color on the ventral surface and a little more luster on the dorsal side. The material is firm and in good condition. The two holes have been bored from the ventral side of the shell, having a crater of 5 mm and an actual aperture of 3 mm. The entire specimen in each case presents a smooth, well-polished appearance.

Besides the above large specimens, eight complete and three broken pendants of a smaller and somewhat different type were recovered. These range in length from 30 to 70 mm and rather suggest imitation animal teeth or claws. All are perforated for attachment, probably to a necklace (pl. 9, fig. 2, *i, j, l, m, n*). They are smoothly polished with neatly bored holes and fall into two main classes, an oval, well-rounded form (pl. 9, fig. 2, *i, l*) and a more triangular type with straight sides (pl. 9, fig. 2, *j, m, n*). Several of these are much eroded, apparently as the result of exposure. Since the majority were found in place, undisturbed by later digging, it is probable that the exposure occurred before they were placed in the ossuary. One of these (pl. 9, fig. 2, *i*) appears to have been made of bone but is of the same shape as the others. This last specimen recalls a similar though much eroded bone pendant from house 1, Lost Creek (pl. 9, fig. 2, *k*).

In all, 85 cylindrical shell beads, all with well-bored holes for stringing, were recovered. They were scattered throughout the pit but occasionally occurred in groups of 12 or less. None were found in alignment suggesting definite strings. They are of various sizes, the largest being 15 mm in diameter with a 4-mm hole, the smallest 6 mm in diameter with a 3.5-mm hole. In each case the beads were flat on both sides and had vertical edges. The type is illustrated (pl. 11, fig. 2, *c*), although these particular beads come from another site. Many of the beads from the Graham ossuary are stained rusty red and have been considerably eroded by previous exposure. Some of them occurred in recently disturbed soil but many were from undisturbed areas. As in the case of other artifacts previously discussed, it would appear that the beads had been exposed for a considerable period prior to their deposition in the ossuary pit.

There are nine cylindrical shell beads, the longest 20 mm with a diameter of 11 mm, and the shortest 10 mm with a diameter of 7 mm (pl. 11, fig. 2, *e*). Holes have been bored from each end and taper markedly toward the center in all but one bead. The latter has a straight 5-mm hole through one half, meeting a straight 3-mm hole

on the other end. The majority of these specimens have a rusty red and white mottling and are considerably eroded from previous exposure. This condition, like the method of boring the hole from each end, is well shown in the illustration (pl. 11, fig. 2, *e*). Here again recent exposure cannot account for the erosion, as the majority of the beads came from various undisturbed areas. Unfortunately, no samples of these beads were sent to Dr. Baker, hence the shell is unidentified. To the unpracticed eye, however, they suggest a marine rather than a fresh-water species of mollusk.

Sixteen flattened and bored fresh-water snail (*Anculosa praerosa* Say) shells were found in association with the partial skeleton of a child at a depth of 2 feet in the east-central portion of the pit (pl. 11, fig. 2, *f*). These have been ground flat on the ventral surface and a rough hole broken at one end, which, with the natural aperture, might be used for stringing the beads. According to Dr. Baker, this particular species is common in the Ohio and Wabash Rivers and southward, but is not known to occur west of Illinois. He suggests they were probably obtained through trade with Illinois tribes. A similar type of shell, identically worked, was found by Harrington (1920, p. 229, fig. 37) in Caddo territory in Arkansas. A number of unworked shells of this species were found in cache 1, house 1, Lost Creek.

Associated with the same child's remains were five olivella (*Olivella jaspidea* Gmelin) shells with a neat hole bored through the small end in line with the natural aperture (pl. 11, fig. 2, *h*). This is a marine species from the Gulf or Atlantic coast. They average 14 or 15 mm in length, a small part of one end having been flattened for boring. Unworked shells of this species were also found in cache 1, house 1, Lost Creek.

One other shell bead was found. It had a single hole pierced opposite the natural opening. The species (*Marginella apicina* Menke) is a marine form from the Florida or Gulf coast. The present specimen is 12 mm in length.

A unique shell artifact carefully worked from some heavy shell, probably that of the Gulf coast conch (*Busycon perversus* Linn.), is hard to classify (pl. 11, fig. 1, *b*). It has been neatly ground down on all edges and has a bowl-like depression in the larger end. Along one side are two groups of bored holes, one group of two, the other of three. In the group of three the two end holes open out to the edge of the artifact. Except for the holes along the side, the shape of the artifact most strongly suggests the shoehorn in our own culture. It was probably used as part of a spoon or dipper. With a wooden handle lashed along the side of the perforations it would serve the

latter purpose admirably, and with a similar shell bowl lashed on the other side of the handle it would have been doubly effective. The artifact is 70 mm in length and 50 mm across at the widest end. It was found at a depth of 10 inches on the eastern border of the pit in soil undisturbed by any recent digging. The shell retains considerable luster and is in an excellent state of preservation.

WORK IN COPPER

Two very similar copper artifacts from the Graham ossuary pit are, to the best of my knowledge, the first aboriginal specimens of this material reported from Nebraska. The first of these (pl. 9, fig. 2, *g*) was found on our dump heap, and although it came from the central portion of the pit its exact provenience is unknown. The second was found at a depth of 12 inches also near the center of the pit. Unfortunately, the site here had been badly torn up by previous digging, and it is probable that the artifact had been disturbed at this time. The first object found was a thin disk of much oxidized copper with a small (3 mm) hole punched through the center. The second specimen is of the same type but is much more complete, as the illustration (pl. 9, fig. 2, *f*) indicates. The outer edges of this disk have been hammered around a similar disk of wood, and the hole has been punched through from the copper face. The complete disk is 54 mm and the hole is 3 mm in diameter. The first fragmentary disk (pl. 9, fig. 2, *g*) is not part of the second artifact, for it overlaps the opening above the wood filler. It was probably part of a similar object, one side of which had been broken off. The specimens are somewhat irregular in thickness, much oxidized, and dull green in color. Although no analysis of the metal has been made, the nature of the artifacts and of the site generally suggest purely native provenience. Their purpose is unknown, but they would have served admirably as ear ornaments, pendants, or plume holders.

Besides the two artifacts just described, several very small fragments of copper were found nearby. They were probably parts of the same specimens. The only other metal object was a small piece of galena encountered at a depth of 12 inches on the south side of the pit.

NEGATIVE EXCAVATIONS IN VICINITY OF GRAHAM OSSUARY

At the conclusion of the main excavation in the Graham ossuary a considerable number of trenches and pits were sunk in various parts of the summit and upper slopes of the hill in order to determine

whether there were similar pits nearby. For the same reason a trench was run across the high ridge about 200 yards to the northeast (fig. 8, site 1a). No evidences of human disturbances were found, and if other pits exist here we were unable to find any trace of them. Since an area 5 feet square, covered with limestone boulders and jasper slabs, had been noted on a hill about one-half mile to the southeast, we also sank pits here (fig. 8, site 1b). The stones were all on the surface of the ground and after removing these we sank a trench to a depth of 3 feet with negative results. These stones, which are not natural on such an eminence, may have been carried to the spot to form a fireplace, either by whites or Indians.

As previously mentioned, Indian Hill (fig. 8, site 1d), to the south of Graham Hill, received its name from skeletal remains dug up in times past. The entire summit of Indian Hill and many places on the sides have been completely overturned by numerous relic hunters. Since no records of any of this work exist and since the material secured is hopelessly scattered, it is impossible to draw any conclusions regarding its significance. We sank many trial pits on such parts of the hill as had not been completely dug over but obtained only negative results. It is possible that careful excavation on the extreme summit, which we neglected because of its hopelessly torn-up appearance, might reveal deeper and undisturbed deposits. Bertrand Schultz, of Red Cloud, secured many shell beads here and found two nearly complete skeletons. Around the neck of one were many shell beads and the three cut shell ornaments illustrated here (pl. 11, fig. 1, *g, h, i*), which had formed part of a necklace. The ornaments are cut from the shell of a fresh-water mussel. A priori it might seem logical to suppose that there was once an ossuary pit on Indian Hill as there was on Graham Hill, but evidence as to the exact nature of the former site is too fragmentary to support any conclusion. It may be significant that Schultz does not report any pottery from this site, nor did we find any, either in our trenches or on the dirt piles of the former excavations. On a low knoll to the northwest of Indian Hill (fig. 8, site 1e) a trench 4 feet deep yielded a few bits of burned clay and charcoal in the upper 2 feet, but no other traces of habitation. There should be aboriginal house sites in this vicinity, to judge from the favorable location just above the stream with its bottom lands and below the burial hills. However, our trenches here did not find them. The arroyos and canyons in this vicinity yield many fossils, and the bluff region along the Republican River generally may well yield much more ancient traces of man than those already reported. It may be mentioned that members of our party visited a large rock

shelter or cave just southwest of Indian Hill, locally known as "Buffalo Bill's Cave". It is a limestone formation with slightly smoke-blackened walls but has no soil deposit on the floor and is therefore sterile from an archeological standpoint.

CONCLUSIONS REGARDING PRAIRIE DOG CREEK SITES

From the foregoing it is clear that we only sampled the sites in the vicinity of the junction of Prairie Dog Creek and the Republican River. It is evident that at least one village site similar to that described from Lost Creek is located in the corn fields below the Graham ossuary. It is also probable that there are other burial places in the vicinity and that extremely careful excavation on the summit of Indian Hill might yet recover valuable details in regard to this badly looted but undoubtedly significant site. From the information so far available concerning Indian Hill we are unable to state whether it is similar to the Graham ossuary or to the Marshall ossuary which will be described shortly, or whether it is unique in possessing complete interments. Careful work around and under the looted areas may yet answer these questions, and the scientific excavator who is fortunate enough to discover an untouched burial place of this type will obtain even more valuable information.

Concerning the Graham ossuary it seems most probable that this communal pit was used for the ultimate disposal of human remains previously exposed elsewhere. The fact that many of these bones are charred suggests that the racks or scaffolds on which they had been exposed may have fallen down and the bones been scorched by prairie fires. From time to time these remains were gathered up with such votary offerings as remained with them and thrown into the pit, where they were covered with soil. Such an explanation best accounts for the utterly haphazard disposition of the bones and the weathering of the artifacts as well as the occasional charring of both bones and offerings. It is noteworthy that no individual pits for interment occurred; rather a general area, approximately 24 feet square, was used in common and presumably over a considerable period. Beyond once more referring to the close similarity between the cultural remains from this ossuary and the material from the Lost Creek houses, we will leave further consideration of cultural correspondences for later general discussion.

OSSUARY ON THE REPUBLICAN RIVER (MARSHALL SITE), HARLAN COUNTY

On the Marshall farm, 3 miles west and 2 miles north of the Graham site and close to the south bank of the Republican River, is located

a somewhat different type of prehistoric ossuary (fig. 1, site 28 and fig. 8, site 2). This site was called to my attention by A. T. Hill, and with the permission of the owner we carried on excavation work here August 5 to 7, 1930. Since the place is well known to local collectors, it has been much dug over. Fortunately, our excavations revealed small undisturbed areas under old dirt piles, and these gave us a key to the general nature of the interments.

The Marshall ossuary is situated on a point of the river bluffs which at this place approach to within 200 yards of the present river channel (pl. 10, fig. 1). This point rises abruptly to a height of some 50 feet above the first bottom but is somewhat lower than the hills on either side. Since the point is not particularly conspicuous, there seemed no particular reason why it alone should have been selected for burial purposes. Nevertheless, surface examination and some trenching on the more conspicuous points to the east and west revealed no traces of other burials. At first glance the extent and random nature of the previous digging (fig. 11) made further excavation seem futile. However, the occurrence of a considerable number of shell beads and human bone fragments at the mouth of a badger burrow on the north end of the hill seemed to indicate the existence of some undisturbed areas under the dirt pile.

We therefore ran a 24-foot trench across the north end and carried it south by 3-foot sections. The first three sections (fig. 11, 4, 5, 6) were through a badly disturbed area. Although occasional small undisturbed areas were found, they were not large enough to give any idea of the original nature of the site. In these three rows we found 1,500 shell beads, of which about half had been rounded and bored, as well as a large number of very fragmentary human bones. The beads and bones came from both the undisturbed pockets and the dug-over fill. All that could be ascertained in regard to the original deposit was that it reached a depth of 6 feet in certain places but averaged only about 14 inches deep at both ends of our trench. The occurrence of small fragments of charcoal in the undisturbed old deposit is worthy of note. In the central part of sections 5 and 6 a definite concentration of bone fragments and shell beads at a depth of from 3 to 6 feet suggested an ossuary pit of some sort (fig. 11, pit 1). However, the earlier digging here, combined with a deep rodent burrow, made it impossible to define clearly the limits of the original excavation. Fortunately, in sections 7 and 8 we found undisturbed areas on both sides of the filled holes of earlier excavations. This, incidentally, was also the end of the badger burrow, and it was from here that the beads and bones first noticed had evidently been carried out.

Fragments of human bone and large numbers of shell beads were here concentrated in three areas or pits (figs. 11, 12, pits 2, 3, 4). These pits were round or oval in outline and in each case were sunk at least 1 foot into the hard undisturbed soil at the bottom of the deposit. Pit 2 was oval in outline with a slightly concave bottom (pl. 10, fig. 5) measuring 3 feet 8 inches long by 3 feet wide. The

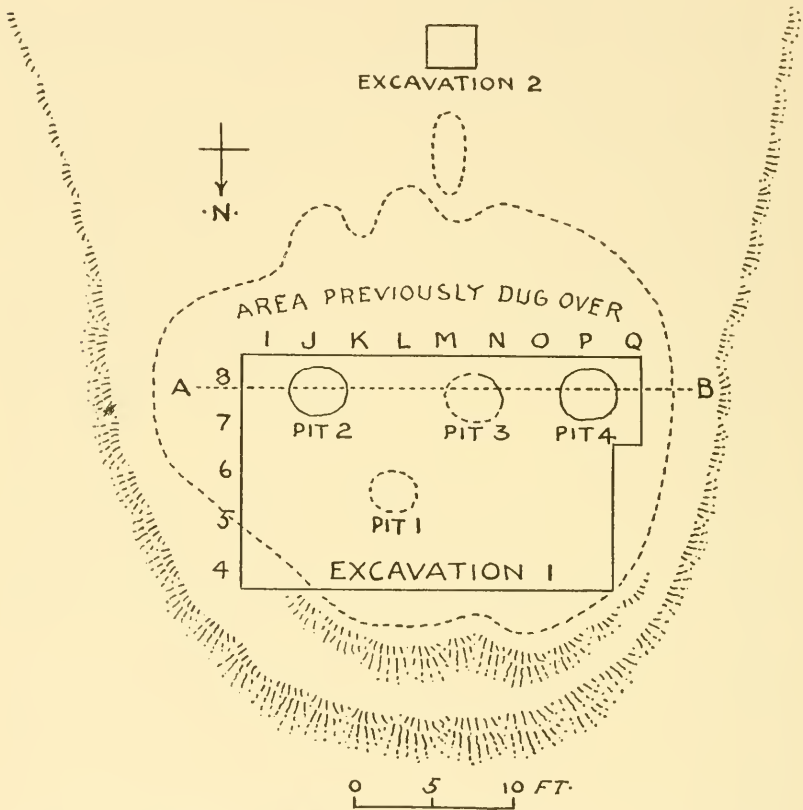

FIG. 11.—Ground plan of Marshall site. Extent of Survey excavations indicated by solid lines, previous digging by dotted lines; A-B, cross-section shown in figure 12.

depth of the bottom from the original surface was 6 feet. The walls of the pit were straight and beyond the pit wall to the east there were no traces of bones or artifacts. The area to the west of this pit had been dug up by previous excavators. Pit 3 was on the western border of this previously disturbed area and only a small portion of it remained intact. To judge from the curve of this remnant, the original pit had a diameter of about 3 feet. The slightly concave bottom was

5 feet from the present surface. Although the bottom foot of the pit was in hard undisturbed soil, above this, on the west, the pit merged into an area of originally disturbed soil through which were scattered a few beads and bone fragments (fig. 12). Whether this original disturbance between the pits extended toward pit 2 is uncertain, owing to the later excavations. Pit 4 was oval in outline, 4 feet by 3 feet 6 inches in horizontal dimensions, and 5 feet 6 inches deep. The bottom was slightly concave, as in the other pits. Like pit 3, the bottom 1 foot 6 inches extended into undisturbed soil, but above this depth pit 4 merged into an originally disturbed area containing some bones and beads (fig. 12). In both pits 3 and 4 the greater number of bones and beads were concentrated on and just above the bottom, whereas the slight mixture above this and between the pits was haphazard.

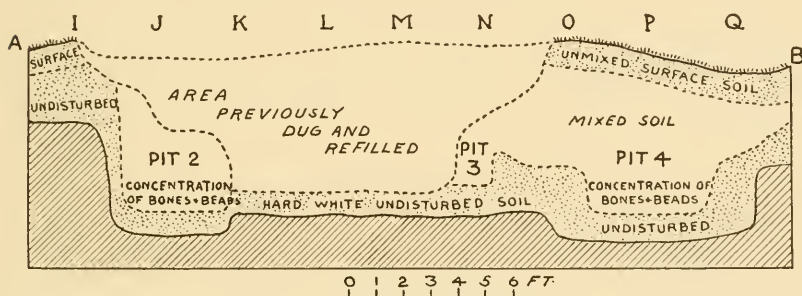

FIG. 12.—Cross-section of Marshall site. Hachures indicate unexcavated soil.

Within the pits the human remains were massed in the bottom 2 feet and with them were large quantities of shell beads. As can be seen (pl. 10, fig. 3), there was no natural grouping of the bones. They had been thrown in en masse, and both under and over them shell beads had been scattered apparently by the handful. Occasionally short strings of evenly matched beads were noted in situ, but as a rule the beads, both bored and unbored, were in heaps. Bones of all sorts were intermingled, and each pit contained the remains of numerous individuals. Many of the bones were broken and some were burned. Likewise many of the beads were calcined. No complete skulls were found, and skull and jaw fragments were rare. Mr. Hill and Mr. Brooking of Hastings, Nebr., earlier obtained one adult skull at this site, which is now in the Hastings Museum. From pits 2, 3, and 4 at least 5,000 shell beads were recovered, as well as two large boxes of human bones. No detailed study of the human remains has yet been possible, but they await further research in the Nebraska State Museum.

ARTIFACTS FROM MARSHALL OSSUARY

Shell beads were the predominating and almost the only type of artifact found in this entire site. Over 8,000 beads were recovered in our own excavation, and very many times this number have been removed at various times by local collectors. The entire dug-over area is impregnated with shell beads, their very abundance causing them to be neglected by the collectors. In addition, as previously stated, they occurred by the handful in the lower portions of the undisturbed ossuary pits. The various types and sizes are shown (pl. 11, fig. 2, *b, c, g*). About half of those recovered were ground flat on the edges and perforated (pl. 11, fig. 2, *c*), whereas of the remainder all were rough on the edges and about 10 percent were unbored (pl. 11, fig. 2, *b*). As many as 25 evenly matched ground and bored beads were found in alignment just as the string of beads was thrown into the pit. The fact that all of the ground beads are perforated, whereas many of the rough disks are not, indicates the probable method of working. Apparently, the shells of a fresh-water bivalve were broken up, ground approximately round on sandstone or broken to shape, bored, strung on some stiff wood fiber and then rolled on a slab or between two slabs until perfectly smooth and round. This is the method employed by the Pomo and other California tribes, and the same sequence is suggested by the complete series from the present site. Since all stages of this process are represented in the Marshall ossuary, it is evident that both finished and unfinished beads were regarded as especially suitable for mortuary offerings.

In addition to the finished and unfinished beads a considerable number of unworked mollusk shells were found in the Marshall ossuary. Of these Dr. Baker has identified three species:

Lampsilis ventricosa occideus (Lea), also found in historic Pawnee and other sites

Lampsilis anodontoides (Lea), also found at Lost Creek, house 1

Pleurobema coccineum (Conrad), numerous at Marshall site only

It is of interest that none of these shells occurred in the Graham ossuary, nor were any of the marine forms noted there found at the Marshall site. It is uncertain just what other species were used in making the common shell beads, but in all cases fresh-water rather than marine shells seem to have been employed. Besides the usual flat disk beads, one other interesting small bead was noticed which had two neat holes on the same plane, one bored lengthwise and the other at right angles (pl. 11, fig. 2, *g*). Also a single bored fresh-water pearl was found (pl. 11, fig. 2, *g*). The only other shell artifacts found

were two partially broken triangles of thin shell with holes bored in the upper two corners. Several of these small shell gorgets were found here earlier by both Mr. Hill and Mr. Brooking. Only one other artifact was found in our entire excavation. This was a broken and calcined object of worked bone, probably the head of an awl (pl. 6, fig. 1, *f*). The well-rounded knob or head of this artifact is different from any other bone implement so far noted in Nebraska. The abundant shell beads, the one broken shell gorget, and this bone artifact are to the best of my knowledge the only artifact types so far recovered from this ossuary.

Since the disk beads from this site were identical with the much less numerous disk beads from the Graham ossuary we had rather expected to find similar pottery, although A. T. Hill warned us there was none. The latter even offered the boys \$5 for the first potsherd but no one was able to claim the reward. Not only was pottery absent but there was no trace of stone work, nor, aside from the one broken artifact, no bone work. It was truly a "shell bead burial" and therefore different from the Graham ossuary both in content and structure.

CONCLUSIONS REGARDING MARSHALL OSSUARY

Although the extent of the earlier digging for specimens at the Marshall site precludes positive determinations as to original extent and exact nature, certain conclusions may be drawn with reasonable accuracy. There appear to have been a considerable number of small pits sunk in an area at the end of the point approximately 30 feet in diameter. In this regard it may be noted that excavation 2 (fig. 11) was in undisturbed soil and beyond the limits of the burial ground. The ossuary pits, to judge from those revealed by our excavations, were from 3 to 4 feet in diameter and 5 to 6 feet deep. In these the previously exposed human remains were deposited with liberal offerings of shell beads. That different pits were dug at different times is suggested by the absence of a uniform bottom level and by the mixed soil between the upper portions of certain pits. The latter might easily have resulted from digging a new pit alongside a former one, thus accounting for the mixture in the upper levels. That individual pits were intended is clearly indicated by their definite round outline and concave bottom, as well as by the concentration of bones and artifacts in the lower levels (pl. 10, figs. 3, 5; figs. 11, 12). Although it is apparent that parts of numerous individuals were included in each pit, it is uncertain how many individuals were represented either in the

entire site or in each pit. The general fact of reinterment of the mixed bones of the dead with offerings, and the occurrence of shell disk beads in each, tends to link the Marshall and the Graham ossuaries. In details of construction and in the types of artifacts in each, the two sites are different. This, however, is a matter for later discussion.

OSSUARY ON REPUBLICAN RIVER NEAR ALMA, HARLAN COUNTY

On March 18, 1931, A. T. Hill wrote me concerning an ossuary very similar to that excavated at the Graham site. I take the liberty of quoting from his letter, since it is brief and to the point.

I celebrated St. Patrick's Day, as all good Irishmen should, by a business trip down to the Republican Valley. When I got to Alma one of my friends told me he had located an Indian grave which he and some other boys had done considerable work in. I told him we would try to get down there some time this summer to help them work it out, but they insisted that we work it at once as it was impossible for them to keep outsiders from digging it up. So yesterday we went out and very carefully excavated a trench 3 by 12 feet (east and west) and 4 feet deep, finding a culture that exactly duplicates the Graham site, with an abundance of pottery and broken (human) bones, four shell beads and three small clawlike pendants made out of conch shell. The latter are exactly the same as those you found in the Graham site. The location of this burial is about one-half mile south of the Republican River and on the highest hill nearest the river (fig. 8, site 3). We kept a strict record of everything found and its position and I will send you a detailed report as soon as I have time to make it out. I am satisfied from the amount of digging that has been done here that this burial covers as much ground as the Graham site does. The boys are going to protect it if they possibly can so that we can get some more information later, but I know that the site is at least 15 feet east and west and 15 feet north and south.

A later letter of March 23, 1931, enclosed vertical and horizontal diagrams showing the exact location of the 116 human bone fragments and artifacts encountered in the above-mentioned trench. The horizontal plat shows a rather even distribution of bones and artifacts throughout the trench, except that they are scarce in the outer 2 feet on both ends. The vertical plat shows a similar evenly scattered distribution from 8 inches below the ground surface to a depth slightly below 3 feet in the central 6 feet. The outer 3 feet on both sides show that the artifact-bearing layer slants up on each end from a depth of 3 feet to only 1 foot at the east and west ends of the trench. In other words, the artifacts and bones have been deposited in a basinlike excavation and are scattered at random throughout the fill. The situation here was therefore practically identical with that at the Graham site. Mr. Hill notes that the human bones were in very bad condition, being wet and crumbly. No complete skulls, but many skull fragments,

teeth, and other skeletal parts were found to the number of 49. All were disarticulated, and no indication of any complete skeletons or bundle burials were observed.

The artifacts included 30 pieces of pottery, 3 small shell pendants, 5 columnar shell beads, 3 disk shell beads, 4 bone beads, 2 five-notched arrowpoints (NBa3), fragments of flint, pebbles, some yellow paint (limonite ?), mussel shells, a conch shell fragment, and some burnt clay. The pot rims are mainly of the collared type, with incised horizontal line decoration or with regular notching around the lowest and widest portion of the collar (compare pls. 5 and 9). The shell pendants are identical with those from the Graham site (pl. 9, fig. 2, *i, j, l, m, n*). The arrowpoints are thin, beautifully chipped examples of the NBa3 type (see table 2 and compare pl. 7, fig. 1, *c*). A comparison of these artifacts with the findings in the Graham ossuary can leave little doubt that the culture represented in both is practically identical.

Mr. Hill adds that although no village has yet been located at the Marshall site, there is a village site, as yet unexcavated, close by the Alma site. He finds no indication of pit burials in the Alma ossuary, stating, "While we have not excavated the Alma site fully, I do not believe that we will find any pit or bundle burials. Everything in this ossuary seems to be evenly distributed and well scattered. As you will note in the drawing I sent you, the artificial material is about as thick one place as another." (Letter of December 17, 1931.)

OSSUARY ON MUNSON CREEK, HOWARD COUNTY

In the letter just quoted Mr. Hill also mentions a rather unique type of ossuary pit located in the North Loup River drainage 3 miles west of the town of Elba (map, fig. 1, site 16).

At the Lehn site on Munson Creek in the ossuary, which is one-fourth of a mile south of the village, I found a very peculiar situation. We cleaned off a space of ground about 16 feet east and west and about the same dimensions north and south and found charcoal, bones, flint, and pottery. We started to clean this out and found that it had been originally dug down from 18 inches to 26 inches and was not level but declined toward the center. Three feet north of the exact center of this 16-foot square we found an ossuary pit that was 53 inches deep, 78 inches long, and 60 inches wide with rounded corners. We cleaned this out very carefully and found two fairly good skulls and fragments of three others, also found four shell beads of the disk type, three shell beads of the tubular type, two of the three notched arrows [NBa2], one Harahey type knife [NCa], one bone pendant, one thumb scraper, a part of a cedar pole (that had been standing upright and extended up about 2 feet from the bottom of the hole), charcoal, and numerous potsherds. There were human bones of at least eight different skeletons in this hole, scattered from the top of the ground to the entire bottom. One of the skull fragments which was the top part of the

head was found 13 inches below the plow line and two others 17 inches below the plow line. The two fairly good skulls that we got out were 47 inches and 50 inches down. There are several villages, so far as we know now, on Munson and Davis Creeks, and all used the ossuary type of burial containing potsherd offerings with disk shell beads. The pottery on these two creeks is very similar [and] can readily be distinguished from any other pottery that we have found in this country so far. There are some pieces that link in design with the Republican River pottery [i. e., Lost Creek and Graham sites], [but] the conclusion that I am compelled to draw from my observation so far is that there is considerable difference between the Republican River pottery and the Loup River Valley pottery. There will be pieces in all these sites that bear resemblances, but I have reference to the majority of the pottery.

It may be added that all the skeletal remains and artifacts mentioned may be found fully catalogued and accessible for study in the Hill collection at the Hastings (Nebraska) Museum. From the Loup and Republican River valleys we now turn to consider various prehistoric sites along the Missouri River in eastern Nebraska.

VILLAGE NEAR ROCK BLUFFS (ROCK BLUFFS SITE), CASS COUNTY

In the spring and early summer of 1930 considerable work was done in a small prehistoric village site located in the cemetery of the little town of Rock Bluffs. The Rock Bluffs cemetery is above the town on the Missouri River bluffs and about 1 mile to the north (fig. 1, site 20, fig. 13). Dr. G. H. Gilmore knew of a house site at this place, and through his good offices we obtained permission to excavate. The brushy area within the cemetery grounds had just been burned over, and in going over the cleared ground we found three more shallow house pits besides the one previously mentioned. The house pits extended in a north and south line along the ridge for a distance of about 100 yards. Possibly there were other houses in the plowed field to the south, but no surface indications, either pits or cultural detritus, were found there. The same may be said for the very brushy area across the road to the north (fig. 13). The house pits within the cemetery grounds are extremely shallow and show no other surface indication than a slight depression. Without the assistance of Dr. Gilmore's trained eye we would never have noticed them.

The general locale of the aboriginal village is on the first high ridge above the Missouri River and about half a mile west of its present channel. The ridges here are heavily wooded but through the trees one may catch attractive glimpses of the river and of the Iowa bottoms and bluffs on the other shore. To the west the country is rolling, with wooded ridges and small cultivated valleys. There is no water near the site at the present time, though an outcrop of glacial drift a few

hundred yards to the north may formerly have given rise to a spring at this point. The river would appear to have been too far below and too distant to have served as a regular water supply.

According to Dr. Gilmore the most northerly pit at this site (house 1) had been partially opened by Dr. Fred H. Sterns some time around

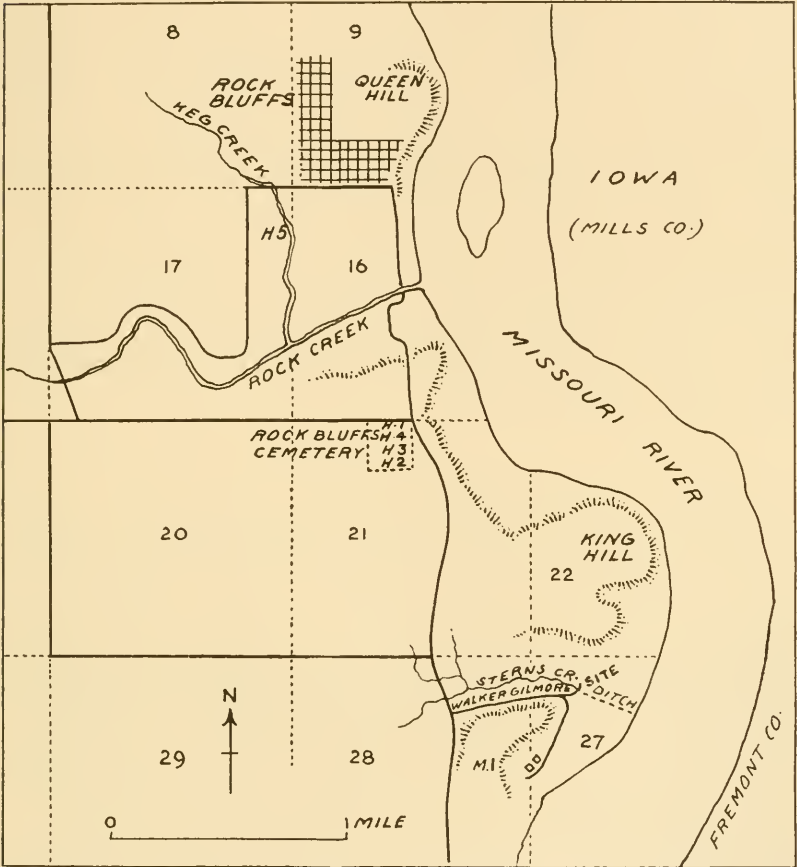

FIG. 13.—Sketch map of Rock Bluffs district, Cass County.

1915. Sterns does not mention the site in his complete manuscript (1915 a), possibly because the excavation was not finished. On our first day at the site, April 12, 1930, some time was spent in an attempt to excavate that portion which Dr. Gilmore thought had been untouched in the former work.

HOUSE 1

In 1930 this house pit was round, having a diameter of 33 feet. The depression was very shallow, perhaps 6 inches in depth and was barely noticeable. We ran a 3-foot trench from the center to the south end of the pit, keeping just to the east of the center line. Since the earlier excavation had been carefully filled in there was no way to tell which half Sterns had excavated other than by Dr. Gilmore's memory. At a depth of 3 feet 2 inches a floor line was encountered, and in the northwest corner of the trench (i. e., the center of the pit and presumably of the old house) a fire area 3 to 4 inches in thickness was found at the same level. The only aboriginal artifacts recovered were a few flint chips and a half dozen potsherds of the same type as those found later in houses 2 and 3. However, near the center of the trench we found a post containing iron nails, indicating that we were in Sterns' former excavations. Since there seemed no way to avoid duplicating much of this earlier work, and as the untouched house pits had just been located, we stopped work in house 1 and filled in. Trial pits in house 2 yielded the surest evidence of occupation, so we transferred our activities to that house pit.

HOUSE 2

This house was indicated in the brushy area at the south end of the cemetery by a faint depression, perhaps 8 inches in depth and roughly 30 feet in circular outline. Work began here April 12, 1930, and was carried on three other week ends during the spring. On the summer expedition of that year we worked in house 2 from June 11 to June 18, when the excavation was completed and the pit filled in. The method of excavation by trenching has already been described in regard to the Lost Creek site. Plate 12, figure 1, illustrates this work in progress on the southeast side of house 2. The presence of trees and brush with the resulting network of subsoil roots made excavation difficult.

As seen in the diagram (fig. 14), the house outline was approximately square with rounded corners, measuring 18 feet from northeast to southwest and 17 feet from northwest to southeast. The edges of the old floor line were difficult to determine with exactitude, except on the southeast side, where there was a clear line of demarcation. This is indicated in the diagram (fig. 14) by solid lines where the boundaries were perfectly clear and dotted lines where they are approximate. The charred remnants of five vertical posts and one post mold, each about 5 inches in diameter, were encountered on and just below the floor line. These are apparently remnants of the inner row

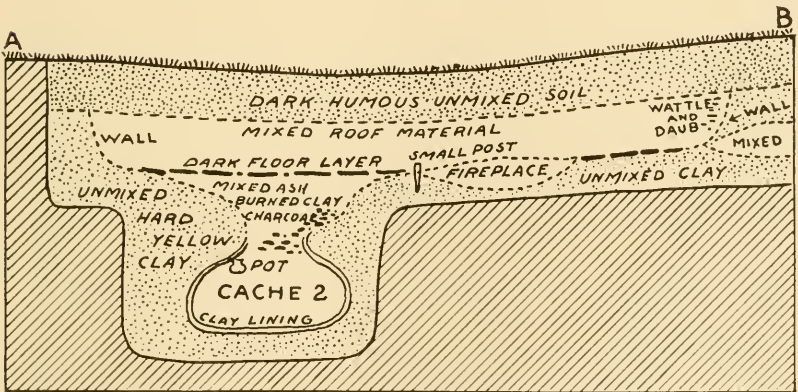
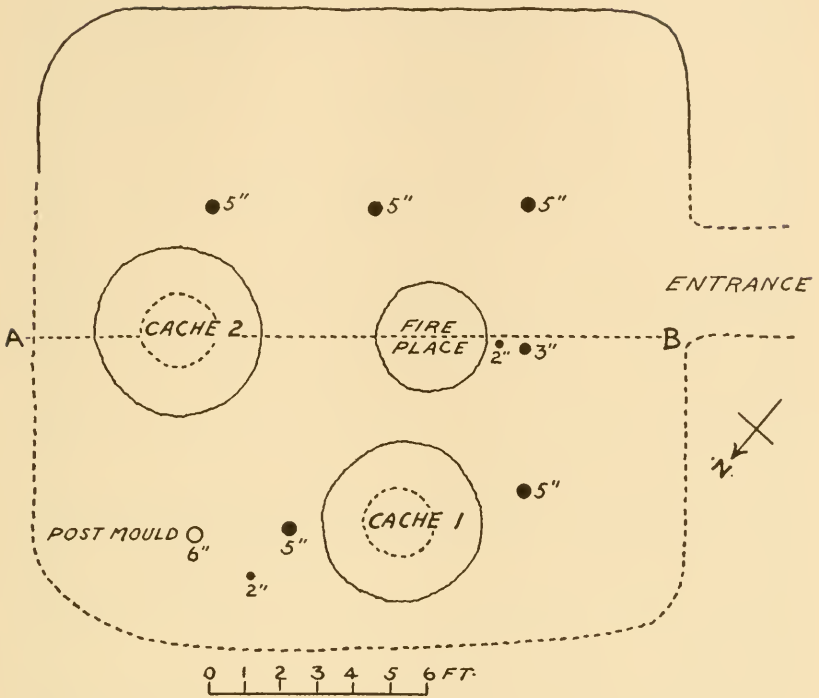

FIG. 14.—Ground plan and cross-section of house 2, Rock Bluffs.

of large posts supporting the rafters from the sides. Just what the complete arrangement of posts may have been is uncertain, for it is evident that some were either missed in the excavation or, less likely, that all traces of them had vanished. No indications of small posts around the outer walls were encountered except one 2-inch post near the northwest wall (fig. 14). This lack of outer posts is evidently significant and is not due to their being overlooked, since there were no traces of any such posts along the southeast wall where other features of house construction were well preserved. From the evidence at hand it would seem most probable that the 5-inch posts form the main interior framework from which rafters ran down to rest directly on the edge of the excavated house pit. The purpose of the 2-inch post previously mentioned and of the 3-inch post just southwest of the fireplace remains problematical. The slanting 2-inch post on the edge of the fireplace (fig. 14) probably served as a crane or other cooking appurtenance. The entrance passage was near the center of the southwest wall. It was 3 feet across and extended at least 10 feet beyond the edge of the house. Since the ground level beyond the edge of the house sloped down in this direction it is probable that this natural slope and the passage floor came together beyond the end of our trench. No posts were found along the passage, but they may have been overlooked.

Considering the vertical soil layers revealed in cross-section (fig. 14), the upper stratum was 1 foot deep at the edges and 1 foot 6 inches in the center, being composed of dark humous material interlaced with roots. It was free of all cultural evidences except where rodent burrowings had introduced these from below. This accumulation had evidently occurred after the abandonment of the house. Below this was a layer of dark mixed soil containing charcoal, burned clay, and a few artifacts. In this layer along the southwest wall near the passage entrance was a considerable amount of burned clay containing imprints of grass and small twigs (fig. 14). This wattle-and-daub material was evidently part of the passage covering, for it also occurred 10 feet out in the passage itself. The mixed layer under discussion had an average thickness of slightly more than 1 foot and was apparently composed of the fallen-in earth roof. At a depth of 2 feet 6 inches in the center and 3 feet on the sides occurred a concentrated layer of charcoal, ash, and artifacts forming the old floor line. This varied in thickness from a few inches on the sides to over a foot near the fireplace. The majority of artifacts, save those from the cache pits, occurred in this layer. The fireplace was about 3 feet in diameter, being composed of ash, charcoal, and cultural debris with red baked clay underneath to a

depth of over a foot. The 2-inch post next to the fireplace, which had a slant to the southwest, has already been mentioned. Below the floor level occurred hard yellow unmixed clay.

STORAGE PITS

Cache pit no. 1 was located on the northwest side of the house (fig. 14). It was circular in outline, 4 feet 3 inches in greatest diameter and 2 feet wide across the mouth. Its greatest depth was 6 feet 3 inches, and it had a slightly concave bottom. It was bell-shaped in cross-section with a wide bottom and narrow mouth. No special lining of any sort was observed. The storage pit was filled with white ash containing charcoal, bone fragments, potsherds, and a few artifacts. The most striking of these was a large complete pot (pl. 13) lying on its side at a depth of 4 feet 5 inches. The illustration shows how strikingly the white ash in the cache pit contrasts with the surrounding soil. The pot was full of ashes and dirt, one unworked mussel shell being the only other object it contained. Besides this pot and a large number of potsherds, one broken shell spoon, several small arrow-points, several end scrapers, and numerous fragments of chipped stone were recovered in cache 1.

Cache 2 (fig. 14) was on the northeast side of the house. Its flattened bell shape is clearly indicated in the diagram. It was roughly circular in outline with a greatest diameter of 4 feet 5 inches and an extreme depth from the ground surface of 7 feet 7 inches. The mouth of the cache was about 2 feet in diameter and 2 feet below floor line. Like cache 1, it contained a large amount of ash, but there was more mixture both of dirt and of cultural detritus than in the former pit. Near the top of the pit in the bottle neck (fig. 14) was a mass of black organic material mixed with large numbers of fishbones, apparently from very large catfish. There was also a large amount of baked clay in the mouth of the pit, and its walls were lined with clay. This clay lining was baked in places as though the walls of the pit when first dug had been coated with wet clay and then a fire had been built on the inside.

Artifacts were more numerous in cache 2 than in cache 1. Just under the organic material previously mentioned a small complete pot was found in close contact with the roof lining of the cache (fig. 14). It was right side up and in perfect condition (pl. 14, fig. 1, *a*). In addition, the cache contained 1 small pottery ladle (pl. 14, fig. 1, *e*), many potsherds (including both highly polished buff and polished incised ware), 1 incised shell spoon, 4 arrowpoints, several broken knife blades of chert, many retouched chert flakes, 3 small end scrapers,

1 chipped and partially ground celt, 2 chipped celts, 1 polishing stone, 1 hammerstone, 1 flat bone awl, 1 polished bone "needle" with a groove around the butt, and 2 fragments of pottery pipes. Besides the artifacts, many unworked rocks, numerous mussel shells, fishbones, mammal bones, and rodent skulls were found. No traces of charred corn were noted, although the black organic mass already noted near the mouth of the pit may have once been corn. This material has not been analyzed.

REFUSE HEAPS

No refuse heaps have been excavated at this site, although they probably occur, since modern gravediggers have thrown up considerable amounts of shell and bone in the eastern part of the cemetery. It was of course impossible to excavate further at such places and our trial trenches away from the graves revealed no middens.

POTTERY FROM HOUSE 2

A considerable amount of pottery was found in this house, for the most part on the old floor level and in the two cache pits. The following lists indicates the total amount and the main ceramic types recovered from house 2:

Complete pots, 2.

Restored pots, 2.

Total number of sherds, 1,126 (rim and handles 78, body 1,048).

Cord-marked sherds, 407 (rims and handles 7, body 400).

Plain ware sherds, 702 (rims and handles 71, body 631).

Incised ware, 13 (rims and handles 0, body 13).

Sherds with slip, 4 (?).

In general the ware from this house is of good quality and feels smooth and hard to the touch. The paste in the majority of cases is fine and the ware flaky in texture. The tempering is of fine grit and difficult to determine in most cases, although occasionally coarser river gravel has been used and such sherds are more crumbly than the others. A tempering containing iron pyrites is sometimes used, and the golden sparkle thus given the surface of the ware is attractive.⁶⁹ The ware is hard and for the more part well fired, though occasional sherds with a black interior indicate insufficient heating.

The prevalent color is a reddish brown, ranging from an orange-buff to an almost black tone. A considerable proportion of the sherds are brick-red. Smoke blackening occurs on the outside of many pieces. The variable colors are due to the degree of firing or smoking and

⁶⁹ This may be the gold flake tempering referred to by Gilder, 1907, p. 712.

possibly to the different clays employed. No examples of a true slip were noticed, though four sherds had a whitish coating on their inner surface suggesting a lime wash. Although this wash did not rub off, it did not appear to have been burned into the pot. As the above list indicates, 62 percent of the sherds recovered were of plain ware which is well polished and often lustrous. Cord-marked sherds made up less than 38 percent of the total, and in most of these the cord marks had been largely eradicated by subsequent polishing. The markings had apparently been applied with cord-wrapped paddles and were mostly on the body of the vessels, only 7 out of 78 rims from the house showing such marks.⁷⁰

Incising as a means of decoration occurs in a relatively small proportion of pieces from this site. In cache 2 there were 13 small sherds of a thin, well-polished brown ware having incised lines on their outer surface. The lines, which had been applied with a pointed implement while the pot was soft, were fine and shallow. Parallel lines and angles are suggested, but the sherds are too small to indicate the larger patterns of which they were a part.

Aside from polishing, cord marking, incising, and the rare painting with a white wash, the main decorative elements of this pottery are attained by modeling. Modeling occurs commonly on rims, lugs, and handles, but only rarely on the body of the pots. Therefore an analysis of all the rim sherds from house 1 will complete the general discussion of ceramic decoration at this site (see table 6, p. 253).

In regard to modeling, the occurrence of a small separate loop handle (pl. 16, fig. 1, *e*) is notable. This had evidently been made separately for insertion into an otherwise completed pot. In all complete pots from house 2, as well as rim sherds having loop handles, the handle appears to form part of the original pot. However the occurrence of an individual loop handle indicates that the riveting in of separate handles also occurred.⁷¹ A fragment of a small pot rim having a human hand in relief (pl. 16, fig. 1, *d*) and a small crude bird effigy (pl. 16, fig. 1, *c*) apparently broken from the rim of a pot are also examples of modeling.

⁷⁰ According to Sterns (1915 a, II, p. 243) nearly all the sherds he recovered from sites of this type were marked with straw-wrapped paddles, often almost eradicated by subsequent smoothing. Examination of Sterns's pottery shows the markings to be similar to those here designated as cord markings. Although many of the marked sherds from house 2 show definite cord imprints, straw-wrapped paddles may have been used on others.

⁷¹ Practiced by the Hopi today and by the Post Basket Makers in the San Juan. Morris, 1927, p. 140. Webb, 1928, p. 279, figures a somewhat similar handle from Kentucky.

The shape and size of the pottery from house 2 is best indicated by the complete and restored pots from the site (pls. 13; 14, fig. 1, *a, d, e, f*). The largest of these is the vessel from cache 1 which was practically complete and intact when found (pl. 13, fig. 1). It had been broken by pressure but was mended by Mrs. Strong. The pot has a total height of 34 cm, a greatest diameter of 33 cm, is 18 cm across the mouth, and has a slightly flaring neck 4.5 cm high. The rim is decorated with thumb-print scallops and has two lugs with vertical perforations on each side. It is burned a dull red on the outside, and the inner surface is a dark gray. The outer surface is smooth and well polished but has no lustrous quality. The globular shape and small round opening are well indicated in the illustration (pl. 13, fig. 1). Since the vessel shows little smoke blackening, it was probably used as a water container, for which purpose it would have served admirably. This is one of the largest vessels so far recovered in Nebraska.

From cache 2 came a small complete pot (pl. 14, fig. 1, *a*). This little vessel has a round bottom, a wide open mouth, two small vertical handles, and a slight flare to the rim. It is interesting to note that the two handles are not exactly in the middle of the pot but are slightly off center. The dimensions of the pot are as follows: 5 cm high and 9 cm across the opening, which is the same as the greatest diameter. In color the pot is a dull reddish brown with a slight polish on the outside. Both inner and outer surfaces are the same color.

A small fragmentary vessel is likewise from cache 2 (pl. 14, fig. 1, *f*). It was restored by C. B. Schultz from a piece comprising about one-third of the original pot. Since the curve of rim and bottom were clearly indicated, the restoration is accurate, although it is possible but not probable that the missing portion may have had handles. The restoration is 5 cm high and 5 cm across the mouth. It is a dull gray-brown in color, has a rough surface, and is crudely made. A small pot having two horizontal lugs with vertical perforations was likewise restored by Mr. Schultz (pl. 14, fig. 1, *d*). It is only 3 cm high, is gray-brown in color, and is very crudely modeled. Another tiny vessel (pl. 14, fig. 1, *e*) suggests a toy dipper.⁷² It is not restored, the tip of the solid handle being broken. Its total length is 4 cm, the bowl 2.8 cm in diameter and the height at the bowl 1.8 cm. The smallest vessel recovered was one half of a flat concave disk of pottery about the size of a quarter. It was gray-brown in color, rough in texture, and is the smallest "vessel" from house 2.

⁷² There is a striking, though presumably fortuitous, resemblance between this artifact and a tiny Post Basket Maker ladle. Morris, 1927, p. 152, fig. 7.

In general, then, it appears that house 1 pottery is usually globular or bowl-shaped, the large "olla" type (pl. 13, fig. 2) and the wide-mouthed bowl (pl. 14, fig. 1, *a*) being common types. With one exception, a single broken sherd suggesting a flat bottom, all the pottery from this house is round-bottomed. As the foregoing description indicates, there is a wide range in the size of vessels (compare pls. 13, fig. 2, and 14, fig. 1, *e*). The same variation occurs in regard to their thickness, which ranges from 4 to 12 mm. The openings of all the vessels are round, and there is usually a slightly flaring rim. Handles and lugs are common, and modeled features such as the hand and bird previously mentioned occur, though less frequently. Collars on the vessels are extremely rare (two cases) and incised designs do not occur on the neck and very rarely on the body of the pots.

No complete tobacco pipes were found in house 2, but two fragments of what appear to have been pottery pipes came to light. Both of these are of light-brown pottery tempered with fine grit. One is cylindrical with a smoke-blackened hole through the center and has five finely incised lines slanting around part of the outer surface. It was evidently the stem of a tubular or very slightly bent pipe. The other fragment is about the same size (24 mm long by 12 mm in diameter) but is slightly darker on the outside and shows no burning within. Only half of this section is present, and it may have been part of a lug or handle rather than a pipe.

WORK IN GROUND STONE

Eight shaft polishers of rather coarse white or gray sandstone come from house 2. Of these five are roughly rectangular, four having one groove, and one having grooves on three sides. The widest groove is 1 cm, and the specimen, which is fairly typical, measures 65 mm in length and 40 mm in width. Another small rectangular polisher is only 30 mm in length and has one broad groove on each face and one narrow groove on each edge. A small, flat piece of sandstone 60 mm long and 35 mm wide has two parallel grooves on one side and two diagonal grooves on the other. One broken shaft polisher (pl. 17, fig. 1, *c*) is 40 mm in length and has one groove.

Eight hammerstones were also found in this house. The best specimen (pl. 17, fig. 1, *j*) is 77 mm in diameter, with ground-out concave sides for holding. On the top is a small artificial pit which conveniently fits the forefinger, and exactly opposite from this pit is the battered striking surface. This type of artifact from its worn surfaces appears to have also served as a rubbing stone. Of these hammerstones four are of granite, three of limestone, and of the latter two

have been exposed to considerable heat. With one exception, a piece of fired limestone used as a hammer on the flat bottom, all are like the one illustrated (pl. 17, fig. 1, *j*) except that they lack the definite finger pit on the upper edge.

No large grinding stones or metates were encountered, but two small polishing stones were noted. One of these, of sandstone, was 90 mm in length and was rough on one side and smooth on the other. The smooth side had been used in grinding paint, as it was colored a bright red. The other broken polishing stone was of granite with sharp corners and two grinding surfaces.

One partially ground celt came from cache 2 (pl. 17, fig. 2, *d*). The butt end is broken, but the remaining portion is 83 mm long, 60 mm wide, and 37 mm in thickness. The material is a hard gray stone, which is roughly chipped toward the butt, whereas the cutting edge is smoothly polished and sharp. There is no trace of any groove. No other polished celts were found.

Although not classifiable as ground stone implements, it may be noted here that many fragments of limestone, limonite, and other mineral substances often showing the effects of exposure to great heat were encountered in this house. These were probably for use as tempering materials, and the slaked lime and limonite would be usable as a paint. Six small, irregular, polished pieces of red mineral, presumably hematite, may also have been used for paint. Unworked boulders and pebbles of various sizes were encountered commonly in the floor layer and in cache pits.

WORK IN CHIPPED STONE

The 19 arrowpoints from house 2 are of five types: NBa (10), NBa1 (2), NBa4 (1), NBb (1), NBc (5). Like the points from house 1 on Lost Creek, these also fall into two main divisions when size is included as well as form. There is the heavy, triangular type (pl. 7, fig. 1, *k, l*) and the small, delicate, and commonly notched type (pl. 7, fig. 1, *b, h*). The former are usually of the gray "Nehawka" flint, the latter of brown or yellow jasper. The sizes of the two types are approximately the same as those from house 1, Lost Creek, although a few of the triangular, unnotched points from that site are larger than the largest from Rock Bluffs, house 2. The form classification of the house 2 points is given in table 3, where it can be compared with that from other sites.

End scrapers were rather numerous in house 2, 24 being recovered. The finest and largest specimen (pl. 7, fig. 1, *s*) is 75 mm in length

and is delicately retouched all over the upper surface. All are of the usual keeled, planoconvex type (pl. 7, fig. 1, *o-s*). Two specimens have a definitely marked median groove for attachment to a handle (pl. 7, fig. 1, *r*). With three rather crude exceptions (pl. 7, fig. 1, *p*), all are very delicately retouched over the upper or keeled surface. Of the entire 24, 5 are of the gray, speckled "Nehawka" flint, 1 of a pinkish chert, and 18 of a gray-white chert or flint.

There are eight chipped artifacts suggesting side scrapers. These are large flakes of gray-white flint, unworked except for retouching along one edge. The longest is a slender, prismatic flake measuring 125 mm. The others are shorter and are oval to round in outline. This type of artifact blends in with another extremely numerous series of small flint flakes either retouched or more probably chipped by use along one edge. These seem to have been employed as knives, the natural sharp edge resulting from the fracture being employed until it was dulled, when the flake was thrown away in favor of a new one. The 31 specimens of this type which were preserved are only a small proportion of those actually found in house 1. This simple knife or small side scraper was the most numerous single artifact type at this site. Of the 31 preserved, 19 are of gray-white flint, 11 of "Nehawka" flint, and 1 of brown jasper. A good example of these simple but presumably effective flake knives is illustrated (pl. 7, fig. 2, *g*).

Besides the use of simple flakes, six delicately retouched knife-blade fragments of gray-white and "Nehawka" flint were found (pl. 7, fig. 2, *i*). All were diamond-shaped or oval in outline, thin, sharp-edged, and without noticeable beveling. These are included in table 3. The largest fragment measured about 75 mm in length.

Besides the above artifacts, some 38 flint rejects and cores were preserved. All showed human workmanship in the form of secondary chipping but were unclassifiable as artifacts. As a rule the flint material in these cores or rejects was of a very poor grade. Besides those preserved, many similar fragments were discarded by us. The main importance of the above lies in their testimony as to the making of stone artifacts in the houses as well as in the fact that the secondary products of such work, i. e., suitable flakes, were also utilized.

Of large chipped stone artifacts, eight roughly chipped celts of gray-white flint were the only examples recovered (pl. 17, fig. 2, *e, f, g*). The majority of these are much battered on the cutting edge, indicating their use as axes. None show any indication of grooves for hafting and it is probable that they were socketed in solid wood handles. The finest example (pl. 17, fig. 2, *g*) is 105 mm long, 50 mm

wide, and only 15 mm in thickness. In the latter regard it approaches the knife blades in type, but it is the lower edge rather than the sides that shows both the most careful retouching and the greatest wear.

WORK IN BONE

Two fragments of scapula hoes, probably bison, were found in house 1. Both fragments indicate that the broad edge of the original tool had been sharpened, and both show evidence of much handling and wear. They are too fragmentary to tell much about their original shape.

Only one complete and one broken bone awl were found here (pl. 18, fig. 1, *f, g*). The complete specimen is 87 mm in length and has been fire-tempered, especially toward the point. The small awl fragment is split from a section of larger bone and is broad, tapering sharply to a point. From the curve of the bone it seems possible that above the break the bone was complete, forming a round handle. The specimen is also well tempered by heat.

Besides five fragments of smooth, polished bone, brown from tempering by fire, only one other bone artifact was found. This is a small, delicate needle or bodkin. It is round in cross-section and has a groove around the butt end. The point is broken off, and the artifact is brown and polished from use and heat tempering. The groove around the butt was evidently added after the artifact was tempered, since it shows no evidence of extreme heating. No other bone nor any antler artifacts were found in house 1, and their scarcity is remarkable considering the relative abundance of other artifacts.

WORK IN SHELL

Three shell spoons (pl. 11, fig. 1, *a, d, e*) came from this house. The most ornate of these (pl. 11, fig. 1, *e*) came from cache 1. Like the other two, the shell is a fresh-water bivalve (species not identified), but the present specimen is decorated with rather faintly incised lines suggesting the wing and head of a bird. The shell has been cut down to form the head of the bird, which also forms the handle of the spoon. The neck and body are separated by a sharply incised line suggesting the gills of a fish; the long feathers of the wing are suggested by faintly incised longitudinal lines; and the head, which has a rounded nose or beak, is indicated by an incised circle for the eye and an incised line for the mouth. The incised decoration is all on the outside of the artifact. The spoon shows signs of considerable use and the lower

edge is broken. Another broken shell spoon (pl. 11, fig. 1, *d*) with a carefully worked lug for the attachment of a wooden handle shows signs of hard use but is undecorated. The third spoon or ladle is even simpler, having a ground notch and a hole over and under the hinge, presumably for the attachment of some sort of handle (pl. 11, fig. 1, *a*). A small hole (1 mm in diameter) has been bored or punched through the center of this artifact.

The only other piece of worked shell is a small, carefully cut piece of shell, 40 mm in length, rectangular in outline with a rounded point. The upper end is broken, and the artifact suggests a tooth from a shell comb. No work in copper or other metal was recovered.

BASKETRY

In the floor layer above cache 2 small baked clay fragments were recovered which bore the imprint of what, at the time, was thought to be corn on the cob. Later, in the laboratory, these imprints were compared with that of charred corncobs from similar sites and with the imprint of coiled basketry. It was quickly apparent that whereas the corncobs left an irregular imprint on modeling clay, the coiled basketry imprint was identical with those on the baked clay. The largest of these baked clay mold fragments (40 mm in length) is illustrated (pl. 16, fig. 1, *f*). From this original imprint it can be seen that the stitches alternate from row to row over what was probably a single rod foundation. These small fragments are a clear indication that the dwellers in house 1 used coiled basketry, although all other evidence has vanished.

ANIMAL AND MOLLUSCAN REMAINS

For reasons previously stated, no careful analysis of the animal remains from house 2 was possible. In the course of excavation the bones of the bison, deer, and various smaller mammals were noted. Deer bones were rather abundant, but bison bones were surprisingly rare. Rodent skulls and bones were numerous in cache 2, evidently having been left by the inhabitants. Other rodent remains elsewhere in the excavation were probably of accidental occurrence, since the already disturbed soil of a house site is favorable to their burrowing activities. At the top of cache 2 a considerable mass of fishbones has been noted. The only identifiable remains were the spines of large

catfish. Shells of fresh-water mollusks were numerous, and the following species from this site were identified by Dr. F. C. Baker :

- Ambicma costata* (Rafinesque) *
- Lampsilis anodontoides* (Lea)
- Lampsilis ventricosa occidentis* (Lea)
- Lampsilis siliquoides* (Barnes)
- Tritogonia tuberculata* (Barnes)
- Elliptio dilatatus* (Rafinesque)
- Lasmigoma complanata* (Barnes)
- Anodontoides ferussacianus* (Lea)
- Ligumia recta latissima* (Rafinesque)

No charred corn or other vegetal remains were noted in the excavation, all trace of such as were formerly present having disappeared. Several fragments of human bone were found in house 1, but these will be mentioned in the section dealing with the disposal of the dead at this village.

HOUSE 3

After filling up the excavation at house 2 a trial pit was sunk in house pit 3, which was a shallow depression 30 yards north of house 2. At a depth of 2 feet 6 inches a large potsherd was found. We therefore cleared an area in the brush 30 feet square. This included the depression, which was only 8 inches below the normal ground level of the surrounding surface. A trench 21 feet long and 3 feet in width and depth across the south end of the pit did not show any sign of house construction or yield any artifacts. A trench was then run at right angles to the first, reaching the center of the pit. Near the center of the pit a few fragments of pottery, chipped flints, and charcoal were found at depths of from 30 to 36 inches, on a poorly defined floor line in the hard-packed yellow clay. Even near the center this floor line was irregular and thin, indicating a brief occupation of the house. Side trenches extended the original width of the house to about 14 feet, but very few artifacts were found, and the lines of original construction were very vague. Nowhere did we encounter any thick, black floor layer nor any trace of cache pits. After 2 days work at this site it was abandoned, because of its extreme sterility. From the evidence at hand a semisubterranean earth lodge either 12 feet square or 12 feet in diameter is indicated. The soil strata were the same as in house 2, and the potsherds and scarce flint artifacts were also identical with those from that house. It is uncertain from our excavation whether house 3 was round or square in outline. All that can be said is that it was similar to house 2 in all details uncovered,

but its thin floor layer and sterility combined with the great number of roots and the hard soil made further excavation at this time impracticable.

DISPOSAL OF THE DEAD

No aboriginal burial ground was found in connection with this village. However, in house 2 several fragments of human bone were encountered. These included two fragments of humerus and two phalanges in the floor layer on the southeast side of the house. They suggest that disarticulated human bodies were kept in the lodges prior to burial or else, though less probable, that these were trophy bones of enemies or evidences of cannibalism. In excavating house 3 a few more fragments of human bone were found, but these were so superficial (5-13 inches below the surface) that they may not have been of aboriginal provenience. It is probable that either ossuaries or crematory pits exist near this village, but none has been reported.

HOUSE SITE NEAR ROCK BLUFFS (HOUSE 5)

In 1911 a prehistoric house site on the western edge of the town limits of Rock Bluffs was excavated by Dr. G. H. Gilmore. The material saved from this site he presented to the Archeological Survey of the University of Nebraska in May 1930. Since the material came from the vicinity and closely approximates that obtained in house 2, it is described at this time.

The site was a shallow depression some 35 feet in diameter located in the woods on a low ridge west of a little creek, locally known as Keg Creek (fig. 13, H5). The digging was somewhat haphazard, and aside from the fact that most of the artifacts occurred in a black floor layer about 3 feet deep and in one cache pit 6 feet deep, there is little else on record. Dr. Gilmore, who worked with us in house 2, stated that conditions in house 5 were very similar.

POTTERY

Only such pottery as seemed to be restorable was saved by Dr. Gilmore. In all, there are 67 sherds, 15 of rims, and 52 of body portions. Of the rim sherds 7 are cord-marked, 8 plain, and of the body sherds 12 are cord-marked and 40 plain. The paste, tempering, and surface finish are identical with these characteristics in the pottery described from house 2. Some sherds show unusually clear cord marks extending in a vertical direction over the vessel and for the most part horizontal to each other. Other sherds show a criss-

cross of cord marks suggesting the use of a cord-wrapped paddle. Two sherds show the gray-white wash on the inside already encountered in sherds from house 2. There was no positive indication of shape, though the curve of all sherds suggested round bottoms. In thickness the ware ranged from 4 to 15 mm. The main decorative effects were achieved by the modeling of rims and handles. Classified under the headings used for rim classification in house 2, these are listed in table 6 (p. 253).

The above list includes one-half of the distinct rim types described from house 2 and indicates the close similarity between the ceramic remains from both houses. The sherds from house 5 show proportionately more cord marking, especially on the necks of vessels, but this preponderance is due more to the selection of similar sherds for restoration than to the natural distribution of types. The pottery from the two houses is so close in all respects that not only the same culture but the same general time period would seem to be represented.

One complete tobacco pipe of unbaked clay was recovered in house 5 (pl. 16, fig. 2, *o*). Although it is gray in color and appears to have been sun-dried rather than baked, it shows evidence of considerable use. Both bowl and stem are caked as the result of long-continued smoking. The artifact is 44 mm long, 39 mm high, 14 mm across the bowl, and 11 mm across the stem. Down one side is a crack or joint in the original pipe material, suggesting that the clay forming the bowl was poorly joined here. There is considerable limy intermixture or tempering in the clay. A fragment of a tubular pottery pipe or pipestem (pl. 16, fig. 2, *e*) also came from this house. This fragment, broken at both ends, is 45 mm in length and conical in shape, with an even perforation blackened from smoke extending from end to end. The surface is a polished dark gray, and finely ground stone is used for tempering. Whether this straight, conical fragment is part of a straight tubular pipe or only the stem of an elbow pipe is obscure, although it suggests the former type. If so, both the tubular and the elbow pipe are represented in this house.

WORK IN GROUND STONE

The most interesting artifact falling under the above category is a broken pottery-making tool or anvil made of limestone (pl. 17, fig. 1, *a*). The stem of the anvil has been broken off, but the convex base is smooth and polished. The fragment is 35 mm in height, 55 mm in diameter across the broken stem, and 70 mm across the polished convex face. It has been ground down from a piece of fossiliferous Pennsylvania limestone. Although much of the pottery—in fact one

might say most of the pottery—from Nebraska suggests lump modeling and the use of the paddle and anvil method, this is the only definite artifact of the latter type so far recorded from the State. It calls to mind a somewhat similar artifact (pl. 17, fig. 1, *b*), also presented by Dr. Gilmore, which came from the surface on the Joe F. Behrns farm near Nehawka, Cass County (see map, fig. 27). The latter object is ground from a soft blue-gray indurated clay and has a rounded horizontal handle and a slightly swelling concave disk on the bottom. The artifact shows the patination of long use and suggests a tool for shaping the outside of pottery while using a rounded stone or usual pottery anvil on the inside. The material of which it is made is too soft for use as a pestle or hammer. The type is unique not only for Nebraska but for North America generally, at least so far as my own observations go.¹³ This matter of pottery techniques in the prehistoric cultures of Nebraska will be referred to later.

Two pairs of red sandstone shaft polishers came from house 5. The first pair (pl. 17, fig. 1, *e, g*) were found in association in the cache pit. They are oval in form, 60 mm long and 40 mm wide, and each has a single 10-mm groove running lengthwise. The two artifacts are rather thin and could easily be held in one hand enclosing a wooden arrow shaft to be polished by an up-and-down motion. The other two artifacts were found separately and may or may not have been used together. One is of the "nail buffer" type with a broken end, being 70 mm long and 26 mm broad. It has a single broad, deep groove 17 mm wide. The other polisher is rounded on one end, broken on the other, and has a single groove 10 mm wide on the flat lower surface. It is 95 mm long and 35 mm wide.

As was true in house 2, a considerable amount of slaked lime was found in house 5. Besides three lumps of white slaked lime, there was a large flat slab (125 by 75 by 25 mm) of this material. These pieces are powdery on the surface and whiten a dark surface like chalk. Two lumps of a disintegrating red rock each containing a considerable amount of mica and much battered suggest the application of extreme heat to break them down for use as tempering material. A large lump of tempered but unbaked clay is also reported from this house by Dr. Gilmore. It was not available for examination. There is also a piece of very porous dark gray material strongly suggesting pumice stone. It is extremely light and rough on its surface, one side flattened, perhaps from use as a grinding implement. The

¹³ The "trowels" or modeling implements from the Middle Mississippi Valley group, figured by Holmes, 1903, pl. 34, seem to be rather close analogues and may have served the same purpose.

specimen was submitted to geologists in the Nebraska State Museum, who stated that it was not of volcanic origin but appeared to be clay which had been subjected to intense heat. Fragments of this pumice-like material are fairly common in prehistoric earth lodges along the Missouri River, and although the present fragment may be of peculiarly baked clay, there is no doubt that pumice stone from the deposits on the upper Missouri River was also employed by the prehistoric peoples of this general area.

WORK IN CHIPPED STONE

Two triangular unnotched and unstemmed arrowpoints of "Nehawka" flint come from house 5. One of these is chipped from a flake and is slightly planoconvex, being 40 mm long and 26 mm wide. The base of the latter is slightly convex and the type is NBc, whereas that of the other is the NBa type. These conform to the large unnotched type of point from house 2, Rock Bluffs, and house 1, Lost Creek (see table 3). None of the smaller notched points are reported from the present site.

Two very crude end scrapers come from house 5. They are planoconvex, but the upper part or keel has been only roughly retouched except on the working end or blade of one of them. The latter has a delicately worked edge, but the abrupt working edge of the second specimen is formed by one clean fracture. They are respectively 54 mm and 47 mm in length.

One flat flaked knife blade with rounded ends (NE type) was found. It is of "Nehawka" flint, slightly planoconvex, retouched on the top and on all edges; the bottom is smooth. Whether this artifact, which is 59 mm long, was employed as a knife or as a side scraper is problematical. Five flakes retouched possibly from use along one or more edges are identical with the flake knives described for house 2.

Of the larger chipped flint artifacts only one well-worked celt of gray flint or chert was obtained. It is 85 mm long, 53 mm wide, and 15 mm thick in greatest dimensions and is oval in outline. Across the greatest breadth of the specimen, on one side only, is a suggestion of a chipped groove for hafting as an ax. The edges of the artifact are exceptionally sharp.

WORK IN BONE

Two bone artifacts are at hand from this site. One is an awl of excellent workmanship made from a deer ulna. It is slightly brown from heating and tapers to a sharp point (pl. 18, fig. 1, *l*). It is 123 mm

long. The other is a slender, slightly rounded bone awl split from a section of large bone (pl. 18, fig. 1, *n*). It is broken at the point, only slightly tempered, and measures 200 mm in length. In addition, an unworked but brown and well-tempered cannon bone of a deer comes from this house. This tempered raw material suggests that heat was applied to the bone before it was worked, at least in some cases. The heating seems too evenly applied to be the result of ordinary cooking or burning.

VEGETAL REMAINS

No animal detritus was preserved in the Gilmore collection, but several fragments of charred wooden posts are present. These show the annular rings of growth in cross-section, but the latter are too evenly spaced to promise much in regard to dating. Casual examination of the wood suggests oak or elm, but it has not been accurately identified. Similar post fragments, 2 to 5 inches in diameter, came from house 1. They seem to be identical with those from house 5.

Unusually interesting are five lumps of yellow amberlike resin which were recovered from the cache in house 5. These were submitted to Dr. M. R. Gilmore, of the University of Michigan, for examination. His conclusions are as follows (letter of April 29, 1931):

(1) This resin is from the western yellow pine (*Pinus ponderosus* Douglas). The easternmost arm of the range of this tree extends along the course of the Niobrara River as far as northwestern Holt County, Nebr. Its main range is in the mountains to the west and southwestward in Arizona and New Mexico. (2) The resin was probably valued for medicinal use and for chewing gum. Possibly it also had its uses for incense. (3) This resin would be an incidental commodity obtained and imported to the place where it was found in journeys made mainly for other commodities. The journeys by which it was obtained implied travel on foot to the Platte and then across to the Elkhorn to its headwaters near the Niobrara, then over to the Niobrara. This journey would be more than 400, probably 450 miles, going and returning.

For chewing gum the most common and abundant source in all the region of the Bluestem Prairies was the resin of the Compass Plant (*Silphium laciniatum*). But whenever the resins of pine and of spruce were found on journeys into the Pine Ridge and the Black Hills they were gathered also. The resin of *Silphium* is almost white while that of yellow pine is amber yellow, that of white pine very light yellow, and spruce is darker than that of yellow pine.

VILLAGE BETWEEN THE PLATTE RIVER AND PAPILLION CREEK (GATES SITE), SARPY COUNTY

On June 19, 1930, a scouting trip to locate the historic Omaha village site at the main forks of Papillion Creek brought unexpected results. No trace of the historic village could be found, but by ac-

cident we learned of a prehistoric village near here that had never been dug in. Visiting the latter site under the guidance of Harold Gates, we found it to be extensive and promising. We therefore moved our camp to the place the next day.

It had been planned to excavate in the historic Omaha village of *Pahú thoⁿdathoⁿ*⁷⁴ in order to determine the characteristics of the sedentary Siouan occupation in historic times before excavating any more prehistoric sites. Although it is possible to identify the previous location of the forks before a new channel was excavated for Papillion Creek, the former village remains have disappeared entirely, owing to both the artificial changes in the channel of the creek and the intensive cultivation. A thorough search of the vicinity here yielded only one nondescript potsherd and a few flint chips, and numerous test pits were all negative. It was therefore impossible to carry out our original plan.

The prehistoric village, encountered by accident, was on the farm of J. M. Gates and proved to be unique in that neither pot hunters nor archeologists had dug it over looking for cache pits. The majority of the very numerous earth-lodge sites near Omaha have been gutted in this fashion, but the Gates site had fortunately been overlooked. Even Dr. R. F. Gilder, who has been extremely active in this vicinity for over 25 years, was unaware of a village at this place. The site is also unusual because of its location some distance away from any large river or stream, being about 6 miles west of the Missouri River, 5 miles north of the Platte River, and about $1\frac{1}{2}$ miles south of the main channel of Papillion Creek (see map, fig. 1, site 21). Permission to excavate was readily granted by the owner, and throughout all our work the entire Gates family were helpful in ways too numerous to mention. It is a pleasure to acknowledge our great indebtedness to them at this time. Our work at this site included the period June 20 to July 4, 1930, four week-ends in September and October of the same year, and two days, March 29 and April 11, in 1931.

Located on a beautifully wooded ridge just west of a secondary branch of Papillion Creek, the nine house pits extend in an irregular line a little over 300 yards long from north to south (fig. 15). Large maples and oaks grow on the ridges, and large cottonwoods lean over

⁷⁴ Fletcher and La Flesche, 1911, p. 100. This village, occupied by the Omaha from 1847 to 1854, when they went on their present reservation, was visited and sketched by the artist Kurz in 1851; see Bushnell, 1908, where some of the sketches are reproduced. Gilder, 1907, p. 75, mentions mounds and pits here, but in 1930, when I visited the site with him we were unable to find any trace of either. Also see Blackman, 1905, p. 390.

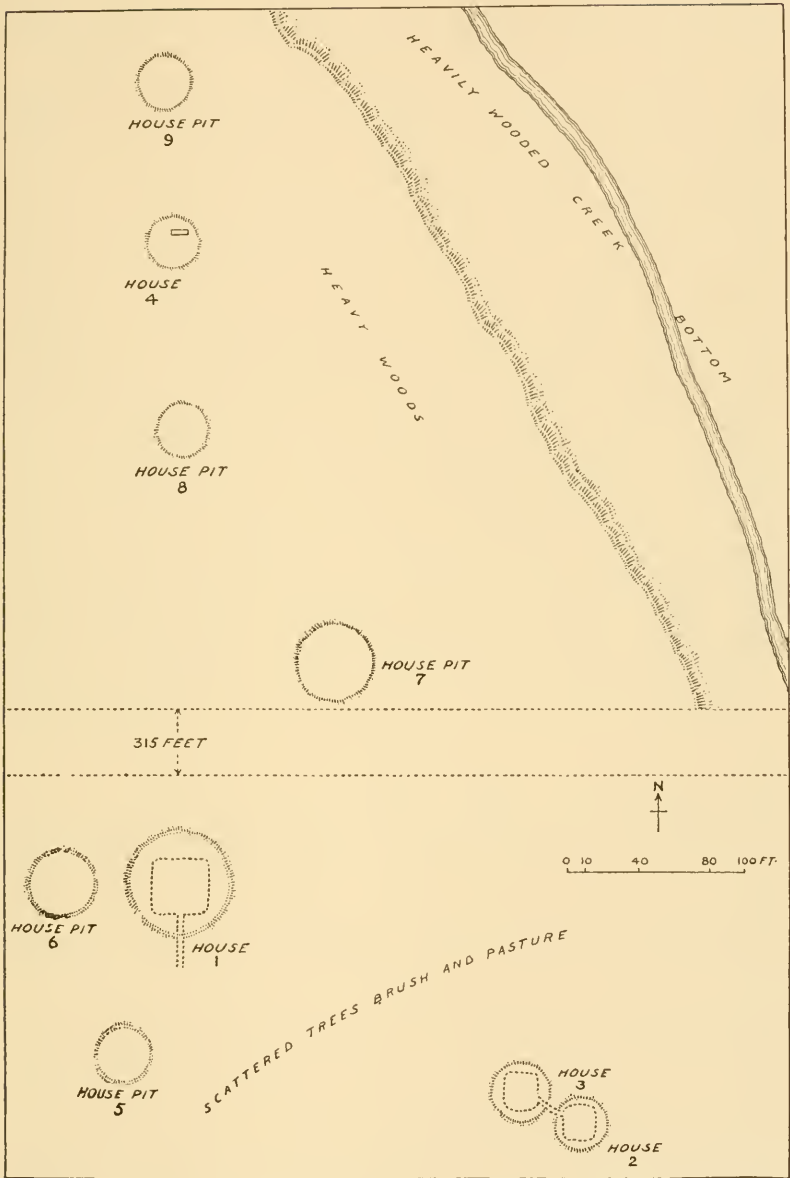

FIG. 15.—Sketch map of Gates site village, Sarpy County. Dotted lines indicate actual floor area of houses.

the steep creek banks. The trees on the ridge were present as far back as any settler living near here can remember. Some of the trees would seem to be well over a hundred years old, but whether the ridges were wooded when the prehistoric lodges were occupied is a matter on which I have no positive evidence. The north end of the village site, like the creek bottom, is heavily wooded, but the south end is more open and at present is used for pasture. Maples over 5 feet in circumference grow in certain of the house circles, and all of the latter were thick with brush. None of the houses are more than a few hundred yards from the creek, which is very small at present. Mr. Gates told us that the flow has decreased markedly in the last 20 years, and where there was a good swimming hole 10 years ago, it is hardly ankle-deep at present. A few artifacts have been picked up along the creek, and one large piece of elk antler was exposed about 4 feet deep in the bank some years ago. Careful searching along the creek bed and its adjoining banks, however, failed to reveal any evidences of human occupation. About 100 yards north of the most northerly house pit a small stream flowing from the west joins the one which flows past the old village. The houses, therefore, are strung along a spur or ridge in the forks of these two streams. The elevation of the ridge, according to the United States Geological Survey map, is 1,100 feet. The creek bed is about 50 feet lower down at this point.

The first four house pits in which we worked have been numbered from 1 to 4 and the others, 5 to 9, which were unworked, are numbered in order from south to north (fig. 15). House pit 1 was by far the largest in the village, being 60 feet in diameter, 3 feet deep in the center, and having a slight rise or 6-inch rim around the north side. The thick brush and the large size of this house pit after clearing but before excavation are shown in plate 12, figures 1, 2. Two maple trees each about a foot in diameter grew in the west-central part of this pit. The remaining vegetation was smaller. House pit 2 had a diameter of 30 feet and a depth of 1 foot 3 inches in the center. It was free of any very large trees. House pit 3, near and connected with house 2, was 33 feet in diameter, having a greatest depth of 10 inches. There were six large trees in this pit (see fig. 19, 1-6) respectively 7 inches, 3 feet 2 inches, 3 feet 2 inches, and the last three averaging 32 inches in circumference. Needless to say, the soil between was a network of roots. House pit 4 was 30 feet in diameter and 1 foot 6 inches deep. The pit was filled with a mass of small trees and brush. No excavation was attempted in the remaining houses, nor were the trees or brush removed.

The measurements of these last pits are therefore approximate rather than exact. House pit 5 was 30 feet in diameter and about 1 foot deep. There were several large trees in and close around the pit. House pit 6 was larger, 36 feet in diameter and about 8 inches deep. It, too, contained several large maple trees. House pit 7 was 45 feet in diameter and about 2 feet deep (estimated) and full of small trees and shrubs. House pit 8 was smaller, about 30 feet in diameter and 1 foot 6 inches (estimated) deep. House pit 9 was about the same size and depth, and both of the latter house pits were in thick brush and contained a number of sizable trees.

Working conditions at this site were made difficult by the heavy vegetation, the large trees with the network of subsoil roots, and the extremely hard, nodular soil of the ridge. This soil was so hard-packed that mattocks and picks had to be constantly employed. This fact in conjunction with the disturbing agency of the roots, as well as the usual insect and rodent work, made determination of floor and feature outlines extremely difficult. The site, although very interesting, was not rich, cache pits were few and rather poor, and after excavating one house entirely, another almost entirely, and sampling two more we left the remainder untouched for future work. It is to be hoped that these will be scientifically worked at a later time. The difficulty of excavation combined with the comparative paucity of artifacts should act as a deterrent to relic hunters, and the site may thus be preserved.

HOUSE I

The outward aspect of this house before excavation has already been discussed (pl. 12, figs. 2, 3). Though the entire house was not excavated, about two-thirds of the floor area was uncovered in such a manner (fig. 16) as to leave no doubt concerning the actual outline. This proved to be subrectangular, with a north-to-south length of 32 feet, an east-and-west width of 34 feet, and a sloping passageway which was traced 31 feet beyond the south wall, although it extended farther. It was extremely difficult to be certain of the exact boundaries of the house in many places, owing to a gradual blending of mixed and unmixed soil. Yet where a line could be followed any distance, as was the case with walls and passage, there was little doubt as to its direction and approximate ending. Aside from a few charred beam and charcoal fragments no wood was preserved. The only indications of posts were three round molds below the floor line (fig. 16). One of these, just northeast of the fireplace, was 12 inches in diameter and may have been part of the central post foundation. The other two

were 10 inches in diameter and were near the walls, possibly forming part of an outer row of posts. Although there was some charcoal in these molds, it was not determinable as being from posts, and it is possible they represent subfloor excavations for some other pur-

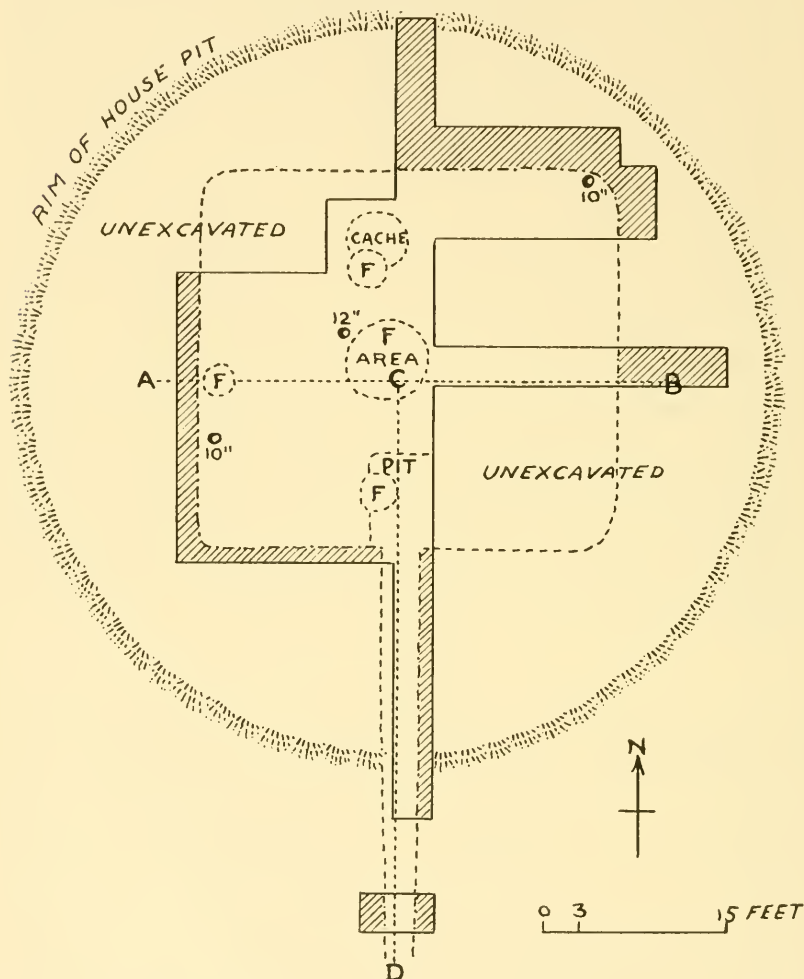

FIG. 16.—Ground plan of house 1, Gates site. Solid lines indicate boundaries of excavations; dotted lines apparent outline of house; F, fireplace; A-B, cross-section shown in figure 17; C-D, cross-section shown in figure 18.

pose. Just west of the center of the house was a circular fire area (fig. 16) marked by mixed ash, burned clay, and charcoal, but there was no clearly defined fireplace. Three small but definite fireplaces were noted, respectively north, south, and west of the central area (fig. 16), and an unusual abundance of charcoal in the wall of the

trench to the east (fig. 17) may represent the edge of another directional fireplace. It is noteworthy that definite fireplaces occurred at three and possibly all four of the cardinal points, and a ceremonial significance seems the best explanation. Where the entrance passage entered the house there was a rectangular pit some 8 feet in length sunk about 1 foot below the general floor level (figs. 16, 18). In the north-central part of the house was the deep subfloor disturbance marked on figure 16 as a cache. Here in an area some 5 feet in

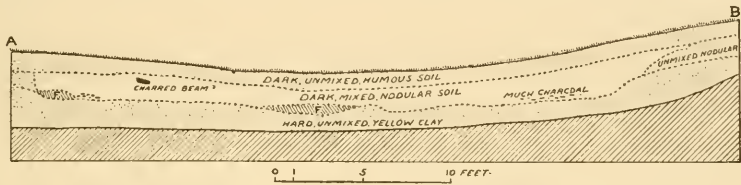

FIG. 17.—Cross-section, west to east, house I, Gates site.

diameter intrusive material was met with to a depth of 8 feet 3 inches. Nothing of significance was found, the intrusive material consisting of a few potsherds, rocks, and charcoal. The disturbed area went down into the clear, hard yellow soil, and aside from the artificial material the disturbed soil was the same in appearance and composition. There was no clear boundary to the disturbed area. Below 8 feet 3 inches test pits and auger borings showed clean soil, and similar tests on all sides were likewise negative. I am at a loss to account for

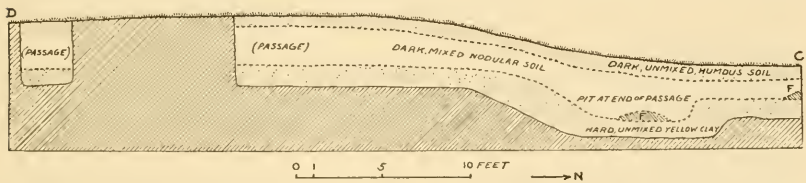

FIG. 18.—Cross-section, south to north, of entrance passage and southern half of house I, Gates site. Hachures indicate unexcavated soil.

this occurrence, unless the disturbed area represents an emptied cache or storage pit of some sort. It was under the north edge of the most northerly fireplace, and there may have been some symbolic or ceremonial connection between the two features.

Considering the vertical soil layers (figs. 17, 18), conditions were very similar to houses already described at Rock Bluffs. Over the top was a dark unmixed layer averaging 12 inches in thickness. This evidently represented the soil and humus accumulation since the house was abandoned. Below this was a layer 15 inches to a little over 2 feet in thickness of hard nodular soil which, within the house area, was

intermingled with charcoal and cultural detritus. A few fragmentary burned beams (fig. 17) occurred in the more barren upper part of this layer, which presumably is the collapsed roof of the old lodge. This occurrence of charred wood in the upper portion of the mixed strata may indicate the burning of the lodge. However, the lack of any charred posts suggests that such burning may have occurred after its collapse. At the bottom of the mixed layer, ash, bits of charcoal, and artifacts were more numerous, indicating a poorly marked floor line. Below this, except where the few subfloor excavations occurred, the soil was a clean, hard yellow clay. Judging from the relationship of the old floor level to the surrounding surface, it would appear that before building the lodge an excavation had been made to a depth of almost 2 feet. It is interesting to note that this almost square semisubterranean earth lodge, some 33 feet on a side, had in the course of time come to form a circular pit 3 feet deep and 60 feet in diameter, the high walls of the remaining pit evidently being formed as a result of wash from the roof prior to its collapse. There was little indication that this lodge had been burned down while occupied, and the paucity of artifacts suggested definite abandonment and the subsequent gradual decay of the structure.

The passageway from house 1 commenced in a pit in the middle of the south wall and extended for over 31 feet beyond the walls of the house. It was 3 feet wide where it left the house and 2 feet 6 inches wide at the 31-foot point. Its depth at the house was 3 feet, and at the 31-foot point it was still 2 feet 8 inches below the surface. To judge from this gradual rise and the present ground level (fig. 18), the entire passage would have been 88 feet long before it came to the surface. However, it may have ended abruptly with a step anywhere beyond the 31-foot point to which we traced it. The passage is remarkable for its steep pitch where it enters the south side of the house and for the rectangular depression or pit in the floor at this place (figs. 16, 18). Even more remarkable is the small fireplace in the center of this pit. A pottery pipe, a large fragment of heavy antler from a white-tail deer, two fragments of bison scapula hoes, two shaft polishers, and a considerable number of potsherds came from the lower portion of this pit. The nature of this deposit in conjunction with the abundant ashes, charcoal, and baked clay indicates that this fireplace had been in use over a considerable period. The pit combined with the steep ascent of the passage at this point would have made for warmth, but the fire in this particular place must have been a decided nuisance so far as the passage was concerned. This circumstance rather strengthens the theory that this

fire in conjunction with the two other fireplaces in the west and north represented some sort of a directional symbolism.

From the available evidence it appears that house 1 had originally been a square earth lodge, presumably used for ceremonial purposes. The latter explanation seems best to accord with the following facts: its unusual size and central position in the village, its unusual entrance pit and long passageway, its three and possibly four directional fireplaces, and last of all the extreme scarcity of broken or whole artifacts as well as animal remains in the floor layer. Furthermore, there is some reason to believe that the building was abandoned and gradually fell to pieces rather than being burned. The house was not completely excavated, owing to the fact that a test of the entire village was desired and time was lacking. The paucity of artifacts in this lodge also made it essential that we work other houses if a representative series were to be obtained from the site.

POTTERY

The paucity of ceramic remains in house 1 is forcibly demonstrated by the following list:

- Complete pots, none.
- Restored pots, none.
- Total number of sherds, 464 (rims and handles 39, body 425).
- Cord-marked sherds, 84 (rims and handles 1, body 83).
- Plain ware sherds, 378 (rims and handles 36, body 342).
- Incised sherds, none.
- Sherds with slip (?), 2 (rims).

In all major characteristics the ware from house 1 and the Gates village generally is closely similar to that from house 2 and the other houses already described near Rock Bluffs. It is similar in color, ranging from a buff-yellow to a dark gray or black, with the former type predominating, in temper (ground stone with a considerable amount of iron pyrites), and in general form. It differs, however, in being less well preserved than was the case in the Rock Bluffs houses. The Gates site pottery is more crumbly, especially just after recovery. The cord-marked sherds from house 1 are evidently paddle-marked, and the cord impressions are irregular. Probably the superior condition of the ware from Rock Bluffs generally is due to better drainage conditions at that site. For the present it will suffice to indicate that the pottery from the two sites is clearly in the same cultural tradition, leaving the matter of relative age for future discussion. The rim types from house 1 are classified in table 6 (p. 253).

As indicated in the enumeration of ceramic remains from this house, there were two small rim sherds of a plain, straight-necked type, which seemed to be covered with chalky white slip. The outer surface of the sherds is a gray-white, and the interior is a light bluish white. The white coloration does not rub off, and since the ware is thin, it almost permeates the sherds from both sides. One small body sherd, 30 mm long, is closely similar but has four broad, deeply incised lines on the outer surface, apparently arranged in a chevron pattern. All four of these sherds are very different from the bulk of the pottery but are closely similar to sherds previously described from houses 2 and 5 at Rock Bluffs.

The tobacco pipe found in the pit at the end of the entrance passage in house 1 has already been mentioned. It is 48 mm high, of a gray-brown pottery tempered with fine grit (pl. 16, fig. 2, *b*). The tip of the stem, which forms an elbow, is broken and the interior of the bowl and stem perforation are black from use. The bowl interior matches the shape of the outer surface, but the stem is perforated by only a small round hole.

In the east-central part of the house a fragment either of the stem of a similar pipe or of the lower portion of a tubular pipe was recovered (pl. 16, fig. 2, *f*). This fragment is 40 mm long and perfectly conical, having a rounded tip with a straight, small perforation through the stem. It is of well-polished red-brown pottery containing fine grit tempering and the central perforation is black from use.

WORK IN GROUND STONE

Three shaft polishers of sandstone come from this house. One is of the "nail buffer" type (pl. 17, fig. 1, *h*). Only the bottom of this artifact has a groove, but the two sides as well as the bottom surface are worn smooth from grinding. Bits of reddish clay adhering to these sides indicate that it was used as a polishing stone for pottery as well as a shaft polisher. Another shaft polisher has grooves on three of the four flattened surfaces. The specimen is 60 mm long, 25 mm wide and high, and the deepest of the three grooves is 5 mm. The third shaft polisher is slightly smaller and has two flat surfaces and two grooves. Besides the grooved polishers of sandstone there is also a flat, irregular fragment, 42 mm in greatest length, with red paint (probably hematite) rather thick on the grinding surface. Another polishing stone of harder rock also has one smooth surface tinted red, evidently from polishing pottery. Three pieces of pumice stone, or the peculiar baked clay previously described were found.

Two hammerstones were recovered; one of hard stone (pl. 17, fig. 1, *i*) has three faces used for polishing and two battered ends. There are two ground-out depressions on the sides, evidently for grasping. The greatest length of this artifact is 90 mm. The other hammerstone is about half as long; it is rather egg-shaped and considerably battered on the larger end.

No celts or axes, either polished or chipped, were found in this house. Four pieces of slaked or heat-decomposed limestone were found. One of these was white, one yellow, and the other two pinkish. The first two were chalky, the latter crumbly. A piece of heat (?) disintegrated granite suggests the preparation of tempering material.

WORK IN CHIPPED STONE

Only two triangular and unnotched arrow points of gray "Nehawka" flint were found in house 1. One of these, 37 mm long and 18 mm wide, is complete; the other is broken. They are of the larger NBa type and therefore accord with larger, cruder, unnotched points described from Lost Creek and Rock Bluffs (see table 3, p. 90).

There are only two small end scrapers from this house, one complete and one broken. The former is 42 mm long by 20 mm wide. They are of yellow jasper and bluish chert and are of the usual plano-convex type.

Seven irregular flakes of gray flint and yellow jasper have been utilized as side scrapers or simple flake knives. The natural edge of the flake has been slightly retouched, presumably through use. Various other flakes and cores were not saved.

There is one well-worked diamond-shaped knife of grayish flint or chert. It is very thin, with neatly retouched edges but no bevel; it measures 102 by 28 mm. Another retouched knife blade of white chert is too irregular for classification in table 2. It is 37 by 18 mm in greatest dimensions and has two edges carefully retouched.

WORK IN BONE AND MISCELLANEOUS MATERIAL

This consisted solely of two fragments of bison scapula hoes. In both cases the longitudinal ridge had been removed, and in one the broad edge had been sharpened. One crumbly antler of a very large white-tail deer was recovered, but it was unworked. Animal remains as a whole were very scarce in this house, and only those from the bison and white-tail deer were identified. No mollusk shells were noted. Three small baked clay fragments containing the impress of grass and small twigs were recovered. Two are black, the other buff color; no other wattle-and-daub material was noted in this house.

HOUSE 2

This house pit at the southeastern end of the village was completely excavated. It was selected because it was far enough distant from house 1 to furnish some indication as to whether all the houses on the ridge were contemporaneous and actually part of one village. The fact that the actual pit contained no trees was also in its favor. As already indicated, the original pit was 30 feet in diameter and 15 inches deep in the central and deepest part. As in house pit 1, the hard, nodular soil could not be sliced smoothly and this combined with the disturbance caused by roots, rodents, and insects, made the determination of internal features difficult.

The floor plan of house 2 was subrectangular, 21 feet 6 inches long from north to south and 20 feet wide from east to west. It thus formed almost a square with the four walls oriented to the cardinal directions (fig. 19). Two clearly defined storage pits (caches 1, 3, fig. 19) and one rather indefinite subfloor excavation (cache 2, fig. 19) were noted. Four post molds were located in the central part of the house but only one of these showed any definite portion of the post intact. This post mold (fig. 19, III) had a short, circular section of charred wood in situ just below the floor line. Three of the posts (fig. 19, I-III) evidently ranged from 6 to 9 inches in diameter; the fourth post mold was about 4 inches across. It is possible that posts I-III represent part of a four-pole central foundation, the fourth post, presumably in the disturbed area of cache 2, not being noticed by us. The function of the smaller post is unknown. The central fireplace, about 3 feet 6 inches in diameter, consisted of 3 inches of red baked clay and several inches of ash and charcoal. A number of limestone slabs and nodules, several of the former coated with baked clay, were on the floor near the fireplace (fig. 21).

The passageway extending from the northwest corner of house 2 into the southwest corner of house 3 is exceptionally interesting. It was 3 feet wide, 28 inches deep, and 17 feet long, extending from east to west with a gradual curve toward the north (fig. 19). No trace of any other entrance passage was discovered in house 2, nor, so far as our excavations extended, in house 3. Either the people in house 2 came in through house 3, through a roof entrance, or else there was an exit for both houses midway between the two on the south side of the passage. The presence of a large maple tree (fig. 19, 7) at this point prevented further excavation along the south wall of the passage. The owner did not wish the larger trees cut down, and even had we done so, the operation combined with the numerous

roots would undoubtedly have destroyed the old strata lines, which were faint under the most favorable circumstances. However, it was possible to follow the north wall of the passage to where it ran into house 3. The width of the passage was clearly indicated at the south end and again at one place near the north end (fig. 19). That

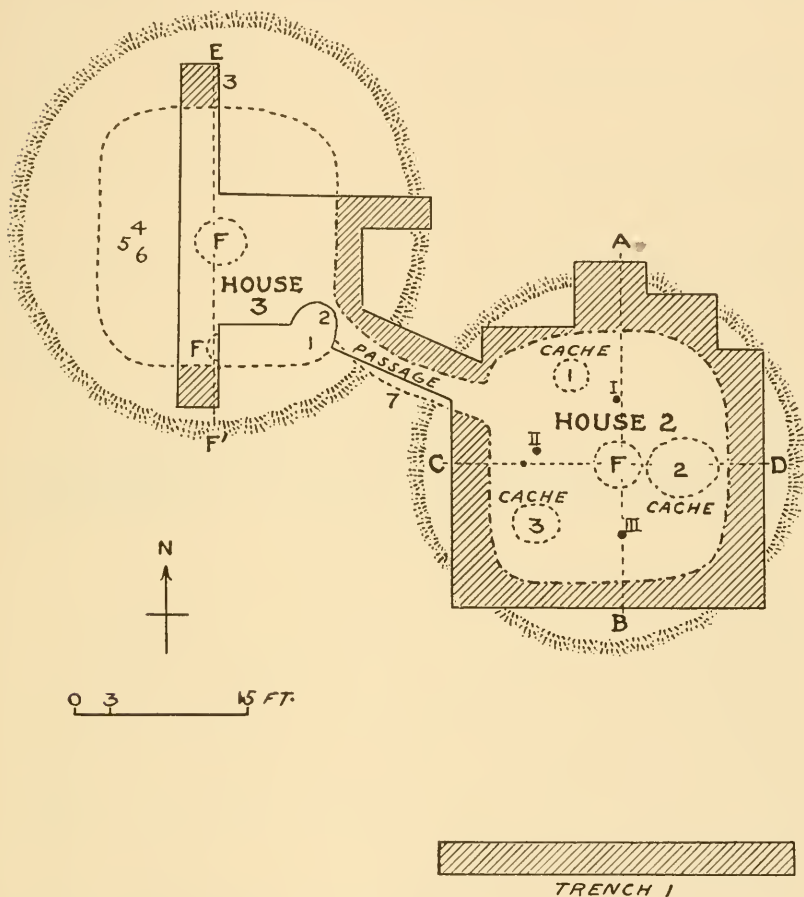

FIG. 19.—Ground plan, houses 2 and 3, Gates site. I-III, central posts; F, fireplace; numerals in dotted circles, cache pits; numerals 1-7, trees; A-B, cross-section shown in figure 20; C-D, cross-section shown in figure 21; E-F', cross-section shown in figure 22.

there was originally a doorway opening to the south from this passageway, midway between the two houses, is a tempting hypothesis. Since no other entrance passage was discovered in either house, this is possible. However, owing to the innate perversity of trees growing in archeological sites it could not be demonstrated pro or con.

In trench 1 (fig. 19) was revealed a good cross-section of soil layers away from the house pits. Dug primarily to intersect any long passage coming from house 2, it yielded little cultural evidence except a few potsherds and flint chips at depths of from 10 to 15 inches. The first 10 inches were of black unmixed humous soil; below this were 16 inches of dark nodular soil with the few evidences of human occupation in the upper portion, then 10 inches of transitional material between the dark nodular and the pure yellow clay, the latter occurring at 36 inches. Cross-sections in house 2 (figs. 20, 21) showed the same general strata, and the nodular soil layer occurred both inside and outside the house area. A darker coloration caused by charcoal and intrusive material, especially along the old floor line, served to distinguish the general outline of the house. Near the borders, where artificial matter was scarce, there was blending between mixed and unmixed soil, hence the difficulty in tracing house

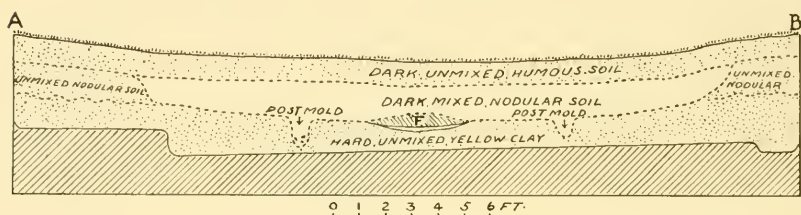

FIG. 20.—Cross-section, north to south, house 2, Gates site.

boundaries. It is the presence of artificial matter and the resulting slight differences in color alone which reveal the old lodges.

In regard to the original structure of house 2 we have evidence to show only that it was a subrectangular earth lodge built in a pit perhaps $1\frac{1}{2}$ to 2 feet deep and that it had no outside passage except the one in the northwest corner leading into house 3. The three larger post molds (fig. 19, I-III), as already suggested, may be part of a four-post central foundation of which the east post was not located. If so, both walls and central posts would be generally oriented with the four points of the compass. Such an orientation of central posts, however, would make the inner roof framework diagonal to the walls. No outer row of postholes, nor any indication of such a row, was encountered. It is hardly possible that any large number of such posts would have been overlooked. Hence it would appear that rafters extending from the central roof framework rested on the edges of the house pit excavation, which may have been banked up. Granting that it had the four-post central foundation already suggested, it would only require beams and rafters of 12 feet or less in

length to reach from post to post and to the edges of the pit. Such an arrangement, owing to the spacing of the assumed central posts, would have given an odd effect and a rather flat roof. With so little internal evidence to go on, it is perhaps futile to attempt too detailed a reconstruction. Careful and complete excavation of a few similar houses in which the entire floor is bared instead of trenched should settle these questions.

It is probable, from the small fragment of charred post just below the floor line and a number of fragmentary charred beams in the mixed layer above the floor, which presumably is composed of roof material, that this lodge was burned down during or just after its last occupation. The presence of one complete pot in cache 1, as well as fairly numerous artifacts in the house generally, suggests the same explanation. That comparatively little charred wood remains in the pit may have resulted from the fact that when the roof collapsed, the earth covering probably put out the fire, leaving most of the wooden framework uncharred and hence unprotected from decay.

STORAGE OR CACHE PITS

As already indicated, three cache pits occurred in house 2 (fig. 19). Of these, cache 1 was clearly defined and contained more numerous artifacts than the others. It was cylindrical in outline, having a diameter of 32 inches and a depth of 6 feet 10 inches from the surface and 4 feet from the floor level. The neck of cache 1 was full of cultural detritus, suggesting that toward the last it had been used as a refuse pit. In the central portion just below the old floor line was a small round secondary excavation in the refuse about 12 inches in diameter and 14 inches deep. It contained nothing more significant than ashes, stones, and potsherds. The composition of the main pit was largely of mixed dark ash, earth, and cultural debris. Near the bottom was a 3-inch lens of white ash in which was one small complete pot and various other artifacts. There was a clear distinction between the cylindrical cache pit and the surrounding yellow clay. The following material was recovered from this pit: 1 small complete pot, many potsherds, 1 broken scapula hoe, 2 bone awls, 1 antler shaft straightener, 1 antler tapping tool, 1 small bone pendant, 2 chipped arrowpoints, 2 end scrapers, 1 chipped stone awl, 2 lumps of red paint, 1 large lump of baked clay, 20 various sized stones, and numerous bird, animal, and molluscan remains.

Cache 2 was puzzling (figs. 19, 21). It consisted of a disturbed area about 6 feet in diameter and extended to a depth 7 feet 6 inches below the surface or 5 feet below floor line. There was no very clear line of demarcation between the mixed and unmixed yellow clay

and almost no ash. The mixture consisted of some charcoal and intrusive stones with a few potsherds and animal bones. Near the bottom of the pit two pottery pipes, a bison scapula digging tool, and several fragments of hematite "red paint" were found. The situation in cache 2 was therefore closely similar to that in cache 1, house 1. Both extended into very hard soil, and both because of their depth required a great deal of labor. Trial pits and auger borings in the bottom and walls of cache 2 revealed no traces of mixture outside or below the area mentioned.

Cache 3 (fig. 19) was in the southwest corner of the house and was definite in outline. It was 42 inches in greatest diameter and extended down to a depth of 7 feet below the surface and 4 feet 6 inches below the floor line. It was round in outline, having a narrow mouth about 2 feet wide and a rounded bottom. The material in the

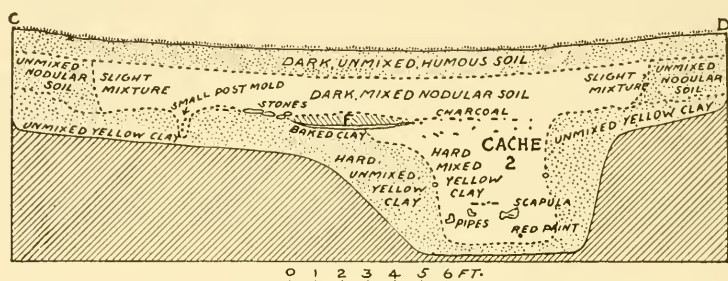

FIG. 21.—Cross-section, west to east, house 2, Gates site.

cache was heavily mixed with ash and contained a large amount of cultural debris. Above the mouth of the cache and just north of it occurred three pottery pipes, one complete and two broken, one of the latter being well modeled as a face (pl. 16, fig. 1, *a, b*). The pipes occurred just on and under the floor line. The cache pit itself yielded many potsherds, animal bones, mollusk shells, and one charred "bean". The latter was unfortunately lost in packing, hence could not be positively identified.

POTTERY

House 2 was much smaller than house 1, yet it yielded almost three times as much pottery. The following ceramic remains came from house 2:

- Complete pots, 1.
- Restored pots, 1.
- Total number of sherds, 1,323 (rims and handles 104, body, 1,219).
- Cord-marked sherds, 259 (rims and handles 5, body 254).
- Plain-ware sherds, 1,025 (rims and handles 99, body 926).
- Incised sherds, 35 (rims and handles 0, body 35).
- Sherds with slip (?), 4 (rims and handles 0, body 4).

Like the pottery from house 1, that from house 2 is highly variable, ranging from coarse, friable sherds to smooth, hard, polished fragments. Fine grit tempering predominates, but coarse grit or gravel is occasionally used. Some of the sherds with the latter tempering have a golden glitter, due to the presence of iron pyrites. Three sherds from this house are exceedingly interesting. They are from one or more highly polished black vessels with their interior surface gray-brown in color. The tempering is crushed and calcined shell, the only example of shell tempering from any of the Missouri River sites excavated by the Survey. The shell tempering, the highly polished and lustrous black outer surface, and the gray-brown inner surface of these sherds make them identical with many sherds from the great Cahokia site in southwestern Illinois. Such a close resemblance, especially in view of the general lack of shell tempering in Nebraska pottery, would appear to be significant of cultural contacts between east-central Nebraska and the St. Louis region in prehistoric times.

In color the ware from house 2 is light buff ranging to dark gray or black. The black seems to be due generally to protracted use over smoky fires. A small proportion of the sherds have turned brick-red in firing, especially on the outside, though some are red on both sides. Unless the sherds have had food burned in them, forming a black crust, they are lighter inside than outside. One sherd is chalky white inside and outside, suggesting a slip or an abundance of lime in the paste. Three sherds are brick-red on the outside, bluish in the center, and dead white on the inside. Evidently some sort of a slip had been applied on the inner surface.

As the foregoing statistics indicate, cord marking as a means of surface finish occurs in slightly less than 20 percent of the pottery. This cord marking occurs on the body and very rarely on the neck. It is irregular in application, as though done with a cord-wrapped paddle. In many cases it has been nearly eradicated by subsequent polishing, and it is therefore difficult to distinguish clearly between rough plain and cord-marked ware. The great majority of the ware is plain and polished, though a high polish or burnish is rare. The three lustrous black shell-tempered sherds previously described are all the more unique on this account. Incising as a means of decoration appears to have been rather unusual and many of the 35 incised sherds are from the same pots. Incisions seem to have been made in angular patterns below the necks of various vessels (pls. 14, fig. 1, *c*; 15, fig. 2, *f*). Several of the thin incised pieces were found to fit on to one large rim sherd (pl. 15, fig. 2, *f*), where they formed a geometric upper body design consisting of a heavier zigzag line with the main

angles filled with hatching, rather similar to the design shown on the complete pot (pl. 14, fig. 1, *c*). The other incised fragments suggest similar designs, and for this purpose various broad and sharp pointed gravers seem to have been employed.

A comparison of rim types from house 2 (table 6, p. 253) with the rim sherd types from houses 2 and 5 at Rock Bluffs and house 1, Gates site, will demonstrate the general uniformity of these wares. Similarly, a comparison with the rim sherds from house 1, Lost Creek, and the Prairie Dog Creek ossuary will indicate rather striking differences between these and the above groups so far as ceramic decoration is concerned.

The form of the pottery from house 2, Gates site, is best indicated by a complete and a restored vessel from this site. The complete pot (pl. 14, fig. 1, *c*) was found in cache 1. It is 90 mm in height, 79 mm across the mouth, and averages 5 mm in thickness. Its globular form, slightly flaring lip, and two loop handles are indicated in the illustration. It is interesting to note that the two loop handles are placed a little to one side of the median line. The outer surface is a rich smoky brown with an oily luster, the latter probably the result of boiling in maize (?) oil subsequent to firing. The inside is rough and gray in coloration. Aside from handles, flaring lip, and surface polish it is decorated by a crude design incised around the mid body. This design consists of a heavy angular line, the upper angles being filled with converging rays, whereas the lower angles have parallel hatching. The design is complete and effective but rough and uneven in execution.

The restored pot (pl. 14, fig. 1, *b*) is considerably smaller and simpler than the above. It is 70 mm high, 66 mm across the mouth, and averages about 3 mm in thickness. It, too, is globular with slightly flaring lip. The fragments from which it was restored had no handles nor is it probable that there were any on the original pot. The outer color is a somewhat smoke-stained yellow-buff, and the interior is the same color without any dark stains. The ware is thin and hard with fine grit tempering. Although many of the sherds recovered suggest considerably larger pots than the above, the general shapes indicated by such sherds are very similar.

House 2 yielded three complete and two fragmentary pottery pipes, all of which are of a modified elbow type. The most striking of these is the bowl of a pipe representing a human face (pl. 16, fig. 1, *a, b*). Using the bowl of the pipe as a head, the native artist had made a huge nose with incised nostrils, a twisted mouth, and slanting eyes, below which appear to be tear channels running down the cheeks.

The face is outlined by a deep, even, incised line and the ears are represented with what appear to be ornaments in them. The face, although grotesque, is very lifelike, and on close scrutiny one gets the impression from it of a man undergoing severe torture. The stem end has been broken off, but enough curve remains to indicate that the pipe was of the semielbow or trumpet type. The blackened bowl takes up all the interior of the face portion, which is 50 mm in length and 20 mm across. There is only a very small perforation passing from the bowl through the upper portion of the stem. It is composed of a hard brown pottery with a rough finish and was found just above the floor line about 1 foot north of cache 3. Another decorated pipe of much the same type came from the same area (pl. 16, fig. 2, *d*). It is made of similar rough brown pottery, is 20 mm across the bowl and has an upper segment of 40 mm and a lower segment of 45 mm. On the outer surface of the bowl are two incised bird tracks, each with a long hind toe. Fragments of still another pipe of similar material were found just above cache 3. Although too small in their restored condition (pl. 16, fig. 2, *j*) to be certain as to shape, they strongly suggest the tip end of a similar pipe.

From cache 2 come two more pottery pipes of the same general type. One of these, restored from several associated fragments, is a very large trumpet-shaped pipe broken off just above the base of the bowl (pl. 16, fig. 2, *a*). Even in its broken condition it is by far the largest pipe from any of our Nebraska sites. It is also of rough brown pottery and has a basal length of 60 mm and an upper length of 55 mm to where it is broken off. Its diameter across the base of the bowl is 25 mm. Both the bowl and the small perforation through the stem are blackened from use. Another smaller pipe with a more flaring bowl from cache 2 was intact when found (pl. 16, fig. 2, *h*). It is made of light buff pottery with a coarse, unpolished surface. The bowl is 15 mm in diameter, its basal length 30 mm, and its upper length 25 mm. It showed less evidence of use than any of the others. As a group it can be said that the pipes from house 2 are notable for their number, their uniformity, and, in one case especially, for their excellent modeling.

WORK IN GROUND STONE

Four rectangular shaft polishers of brown sandstone come from house 2. One of these has a narrow groove on each of the four faces; one has a deep broad groove on one face and two faint grooves on the sides. This artifact is heavily stained on the edges with red hematite paint. The two smaller artifacts have four deep grooves which in

cross-section appear as a cross with rounded segments. There are also six irregularly shaped shaft polishers of sandstone, three with two grooves, one with 3 grooves, and one with a single groove. In length these artifacts range from 55 to 30 mm.

Five hammerstones were recovered. They are of hard stone, rough in contour, and with the sides or ends battered by use. Only one, the largest specimen (54 mm long), has two pecked indentations on the side which serve as grips for thumb and forefinger.

There is one partially ground celt with the butt end broken off (pl. 17, fig. 2, *c*). The material is a hard stone, basalt or granite, which has been chipped and lastly polished to shape. The blade is narrow (35 mm in width) but quite sharp, and the fragment is 70 mm long and 55 mm across at the break, which is just past the middle section. There is no indication of any groove.

Four stone fragments have evidently been employed for grinding paint and polishing pottery. One is a thin oval pebble of hard blue material 90 mm in length with the edges worn and stained red. Two are rough fragments of hard stone, each with one smooth face stained with red. The fourth is apparently only a corner of an evenly rectangular piece of gray sandstone, with two flat surfaces and both remaining edges rounded. One face is slightly hollow. Both faces and edges show evidence of grinding, but there is no stain on any of them.

Two beautifully smooth and much-worn fragments of red hematite were found. These are small with polished faces and edges, and when dampened, they can be used to write with like red crayons. They were probably employed for facial or other decorative painting.

Of the miscellaneous unchipped stone material, 33 fragments of red sandstone, evidently containing much iron, are of interest. These had been subjected to intense heat, which caused their disintegration. Whether this process was intended to produce tempering material or paint is problematical. Five fragments of slaked lime, four white and one pink, will write like chalk. There is also one fairly large lump of the pumicelike material.

WORK IN CHIPPED STONE

Only four arrowpoints were recovered in house 2. Two of these are merely triangular flakes of "Nehawka" flint, crudely retouched on one side with the other side smooth. Because of the plane of cleavage, both are slightly curved. Such points seem rather unpractical for projectiles and may have been employed as small knives or gravers. Because of their aberrant nature, they are not classified in table 3. Another larger point (35 mm in length) of "Nehawka"

flint is heavier, well chipped, and has a definite stem of the SCa type. The end of the stem is broken off, hence it cannot be further classified. The fourth point is small (123 mm long) and delicately worked. It is of the NBa1 type and is also of "Nehawka" flint. A section of a rather large point is broken at both ends, hence cannot be classified.

Four small chipped stone awls or borers are of a locally new and interesting type. One (the smallest) is of brown jasper, the others of gray flint. They range in length from 22 mm to 37 mm. The smallest specimen is the most delicately worked, having a slender, neatly chipped point and a narrow handle or flange which flares out on both sides. It is delicately retouched on all edges. The two intermediate specimens are cruder with definitely chipped, slender boring points and wide, crudely chipped flanges or handles. The fourth and largest specimen is by far the crudest, only the broad point being retouched; the handle is only the flaring natural flake. These are not illustrated here; the general type, however, is of extremely wide distribution.

Six small end scrapers were recovered. They are of the usual type (compare pl. 7, fig. 1, *p*, *s*). Four are of gray-speckled "Nehawka" flint and one of brown jasper. They range in length from 55 to 37 mm.

Three broken knives or side scrapers, two of "Nehawka" and one of a clear white flint, came from house 2. One blade 54 mm in length is oval with rounded ends; it is very thin and well chipped on both sides. A knife blade from house 1, Lost Creek (pl. 7, fig. 2, *k*), is very similar. One broken fragment suggests a diamond-shaped knife without beveling. The fragment is too small for certain classification, however. The third is a thick, triangular piece of "Nehawka" flint which has been retouched to a sharp edge along one side. The upper end is heavy and rough, being composed largely of the limestone matrix. The specimen is 94 mm in length, flat on one face and sharply keeled on the other. The point is sharp and retouched.

A diamond-shaped artifact of "Nehawka" flint, perfectly smooth on both faces and retouched along all four edges, is of unknown use. It is 27 mm in greatest length and 4 mm in thickness. It suggests a gun flint in type but shows no signs of such use, nor is there any other evidence at this or similar sites to suggest Caucasian contacts. A somewhat similar piece broken in half was also recovered.

WORK IN BONE

One complete and three fragmentary bison scapula hoes come from house 2. The complete specimen (42 cm long) was very crumbly when found. The ridges along the bone had been cut off and ground

down and the broad edge was fairly sharp. Another blade fragment (pl. 6, fig. 2, *b*) had been tempered by heating and was well preserved. It had been ground to a sharp edge and had a rounded notch on the side just above the blade. The presence of this side notch has been taken by Sterns as an indication that such scapula artifacts were mounted on straight handles and used as spades. This is possible, but since typical unnotched scapula "hoes" are also found, it may be that the smaller notched pieces are fragments reworked for some other purpose than digging. The other fragments also showed grinding, and one had a rounded notch (as in pl. 6, fig. 2, *a*) at the butt end. None of these were perforated.

A large awl, or more probably hand pick, made from the ulna bone of a bison is rather unique (pl. 18, fig. 1, *a*). It contrasts markedly with a small ulna bone awl (pl. 18, fig. 1, *m*) from the same house. Both artifacts had been heat-tempered. The former is 210 mm, the latter 135 mm in length. Several fragments of split and tempered bones, all more or less worked, were found. Split fragments of deer cannon bone suggested the manufacture of bone awls.

WORK IN ANTLER

Only two artifacts of this material were found, both coming from cache 1. The first of these is a shaft straightener of deer antler (pl. 18, fig. 1, *b*). A slender tine was selected and a 12-mm hole, perfectly round and straight, cut through its base. Another tine branching off at this point had been neatly cut off. One end of the specimen culminates in the slender antler point, but the larger end is broken off. The remaining portion is 165 mm in length. The other specimen of antler is a punch or tapping tool (pl. 18, fig. 1, *e*). It is a curved section of antler with the swelling base at one end and a neatly rounded cut at the other. The surface of the antler has been ground down to perfect smoothness, which with its whitish color gives it the appearance of a section of peeled willow stick. It is 95 mm in length. As in the case of similar artifacts from house 1, Lost Creek, it was probably used for detaching workable flakes from a flint nodule. The larger end is worn as though from being lightly hammered upon.

HOUSE 3

Owing to lack of time and the presence of numerous large trees which made excavation difficult and slow, this house pit was only sampled (figs. 19, 22). From the excavations completed, which reached beyond the walls of the house in three directions, the original

form of the house appears to have been rectangular with an actual length of 22 feet and an approximate width of 20 feet. Two fire areas were noted (fig. 19), a central fireplace about 4 feet in diameter and a smaller fireplace in the central part next to the south wall. The curving passageway from house 2 came into house 3 in the southeast corner. No posts or post molds were encountered, and only small amounts of charred wood occurred above floor level. These deposits were most noticeable near the two fireplaces and in the southeast corner around the passage entrance. Artifacts were exceedingly

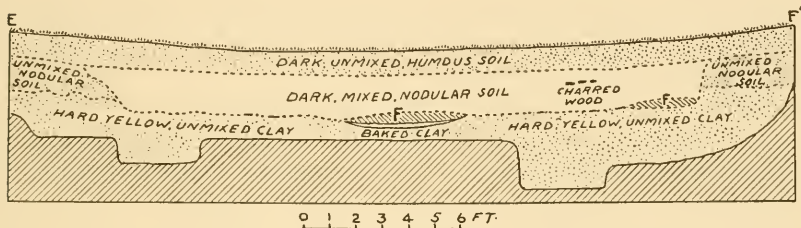

FIG. 22.—Cross-section, north to south, house 3, Gates site.

scarce in this house, but the majority of those found came from the three areas just mentioned. In cross-section the soil layers of house 3 were identical with those of house 2 already described in some detail. No evidence of subfloor pits was encountered nor was any entrance way noted other than that above mentioned.

POTTERY

As was true of other artifacts, very little pottery was recovered from our excavations in house 3, as the following list indicates:

- Complete pots, none.
- Restored pots, none.
- Total number of sherds, 87 (rims and handles 11, body 76).
- Cord-marked sherds, 40 (rims and handles 2, body 38).
- Plain-ware sherds, 44 (rims and handles 7, body 37).
- Incised sherds, 3 (rims and handles 2, body 1).
- Sherds with slip, none.

All the sherds were grit-tempered, the majority being rather thin and hard with fine tempering. A number, however, were thick and coarsely tempered, and these were very soft, almost mushy in some cases. The three incised sherds were exceptionally thin and hard. The color of the pottery was predominantly a light buff, but there were a few brick-red sherds. The thin, hard sherds are more or less uniform in color throughout, whereas the thick, friable sherds are

"blue" and poorly fired in their central section. The incised sherds were almost black throughout. About half the sherds were cord-marked by the paddle technique, whereas the plain sherds were smoothly polished but without burnish.

The rim sherds, while limited in range of types owing to the small number recovered, fall into the same classes as those from houses 1 and 2. One type with a slight collar and incisions extending from the greatest diameter of the collar toward the neck (pl. 15, fig. 2, *c*) is confined to the Gates site, houses 1 and 3. Using the same rim classification employed for both the Rock Bluff cemetery and Gates site houses, the distribution occurs in the limited collection from house 3 as indicated in table 6, p. 253.

The three incised sherds from this house have linear designs extending from below the neck over the larger part of the body. They consist of diagonal and occasionally intersecting lines suggesting the patterns already illustrated (pls. 14, fig. 1, *c*; 15, fig. 1, *d*; fig. 2, *f*). The thin, hard quality of this incised pottery is rather in contrast with the more abundant and heavier unincised ware. Briefly, then, it may be said that the scant ceramic remains from house 3 conform in all major details to those from the other Gates site houses and add nothing that is new.

OTHER ARTIFACTS

Of ground stone artifacts only sandstone shaft polishers and fragments of hematite and limonite paint stones were recovered. There are two polishers, one 63 mm, the other 35 mm in length. The first has a single groove on each of the four faces and one groove across the end; all the grooves are variable in width and depth. The smaller polisher is irregular with four grooves on one face, three on the other, and two on one side. There are four pieces of mineral paint, three of hematite, one of yellow-white limonite.

Of chipped stone artifacts, three well-worked end scrapers of the small planoconvex type were recovered. They range from 52 to 50 mm in length. A fragmentary diamond-shaped chipped stone piece suggesting a small knife blade is the only other definite artifact. Besides the above there are 18 worked fragments of chert and flint. Some of these are crude flake knives, and one core, which is roughly four-sided, seems to have been used for hammering.

HOUSE 4

On March 29, 1931, a test pit was sunk in house pit 4 near the north end of the Gates site village (fig. 15). This was done in order to determine whether the houses in this part of the village represented

the same period and culture as those already excavated at the site. A small trench 9 feet long and 3 feet wide was sunk to a depth of 4 feet in the northeast portion of the depression. Two large rim fragments and a number of sherds identical with others from houses 1-3 and one piece of retouched "Nehawka" flint were the only artifacts recovered. The ceramic remains serve, however, to indicate the close cultural relationship between house 4 and houses 1-3. The cross-section revealed by the trench showed 1 foot 8 inches of dark humous soil, a vague floor line at 2 feet 8 inches, and mixed nodular soil to a depth of 36 inches where the yellow clay began. There was no well-marked floor accumulation, and artifacts of any sort were scarce. The occurrence of 20 inches of dark unmixed soil over house 4 as compared to the rough averages of 12 inches of this layer over houses 1, 2, and 3 is rather remarkable. This discrepancy may be accounted for by the location of house 4 farther down the ridge, where erosion from above may have accumulated more soil, especially in a small, deep house pit such as the 1 foot 6 inch depth to a pit 30 feet in diameter suggests. In any event this marked difference in the depth of soil accumulation subsequent to abandonment between houses yielding identical pottery types indicates the danger of leaning too heavily on the bare fact of subsequent soil accumulation for dating. Intricate factors of local topography, soil analysis, and the exact nature of each accumulation must be considered in such matters, and only close cooperation between archeologist and soil geologist in the field can give trustworthy correlations between depth of soil layers and the relative age of sites. This is a very promising line for future research and can be readily applied once the general nature and distribution of prehistoric cultures in any particular region have been determined by archeological excavation.

ORGANIC REMAINS

Animal remains from excavations at this site were not very abundant; mollusks were fairly common, but vegetal remains were absent except in one case. Deer, especially the white-tail variety, as indicated by antler fragments, were the most numerous animal species represented. Bison remains were decidedly rare except for a few teeth and worked scapulae. Squirrel and rodent bones were fairly common in cache pits. Many other animal remains could not be identified, owing to the lack of comparative material already alluded to. The animal remains as a whole were examined by advanced paleontological students, and no evidence of the horse was encountered. The molluscan remains sent to Dr. Baker included four species from this site:

Amblema costata Rafinesque, *Quadrula pustulosa* Lea, *Truncilla truncata* Gates, and *Proptera alata megaptera* Rafinesque. Besides these four species thus identified there are others not included in the material sent for examination. Unlike certain similar sites, vegetal remains were scarce, the charred bean already referred to being the only example recovered. There is, however, reason to believe that maize was the staple food product of these prehistoric people. Certainly animal remains are remarkably scarce compared to their abundance in historic Plains Indian sites, and the presence of bone digging implements and the development of ceramics point to a horticultural mode of life. Unless charred, vegetal remains are the first things to vanish, and only a fortunate accident preserves them for archeological recovery. No human remains were encountered in the houses at the Gates site, nor could mounds or interments of any sort be located in the time available for such exploration.

VILLAGE AND OSSUARIES NEAR THE MOUTH OF THE ELKHORN RIVER (SAUNDERS SITE), DOUGLAS COUNTY

This exceedingly interesting site was called to my attention by Dr. R. F. Gilder and the discoverer of the burials at this place, A. L. Bishop, of Omaha. On their invitation we visited and worked at the site on May 2, 1931, and again on May 16 and 17. These were the last days spent in the field during the spring season of 1931, and in such a short time the site, which is rather extensive, could only be sampled. Nevertheless, the results of the brief excavation were so interesting that they seem worthy of record until such time as the site may be more thoroughly worked. On our first visit Dr. Gilder, Mr. Bishop, Mr. Yocum, of Logan, Iowa, and Dr. C. W. M. Poynter, Dean of the University of Nebraska Medical School, were present and cooperated in the excavation work.

The prehistoric remains at this place consist of a number of natural rises strongly suggesting artificial mounds, of which two and perhaps all contain human bones. In addition, there are at least five circular house pits on the ridge in close proximity to the "mounds". Nearly all the house pits have been rather badly dug up at some former time by relic hunters, but prior to Mr. Bishop's investigation the "mounds" do not seem to have been disturbed. The site extends for about an eighth of a mile along the river bluffs on the east side of the Elkhorn River (see maps, fig. 1, site 22; fig. 23). The bluffs at this point form a sharp ridge, dropping steeply some 50 feet on the west to the river bottom and more gradually to the east into deep creek canyons.

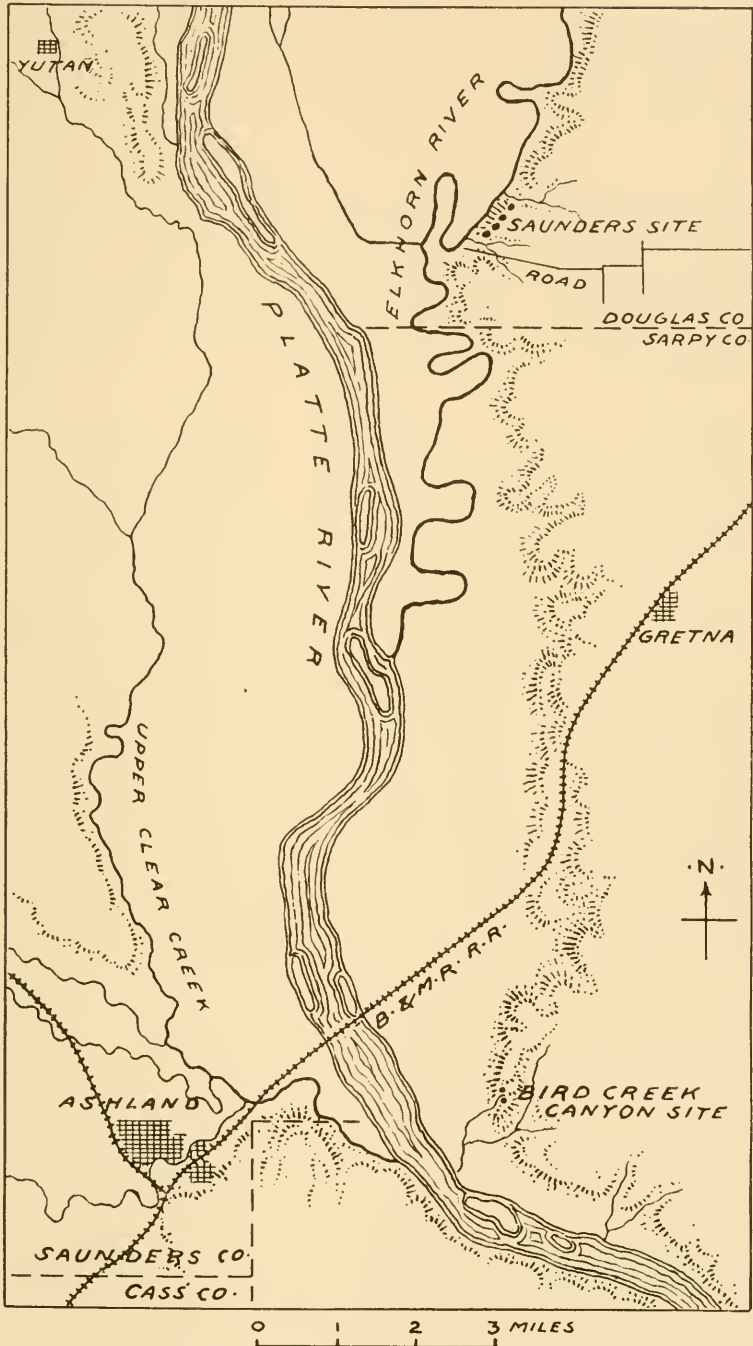

FIG. 23.—Sketch map of Platte River, above and below junction of Elkhorn River, showing Saunders and Bird Creek canyon sites, also Yutan.

The sharp elevations occur on the narrow ridge itself, whereas the house pits are located either between the "mounds" or on the spurs of the ridge which jut out in an easterly direction. There are in all probability other house pits on nearby spurs or ridges which have not yet been located. A considerable portion of the site is on the farm of Mr. Saunders, who kindly permitted us to excavate. The general location of the Saunders site near the mouth of the Elkhorn River, three-fourths of a mile north of the Douglas-Sarpy County line and about 3 miles southeast of Yutan, is approximately indicated on the sketch map (fig. 23). The entire ridge here is well wooded and attractive, with a fine view over the combined Elkhorn and Platte Valleys.

"MOUND" I

When we arrived, Mr. Bishop and Dr. Gilder were digging in one of the central elevations, which for purposes of convenience we may designate as "mound" 1. This was oval in form, being about 15 feet from north to south and 6 feet from east to west. Its greatest height above the adjacent ridge was between 2 and 3 feet, and it formed a noticeable rise. Mr. Bishop had found the site the week before and had previously removed two or three skulls which must have been just below the sod line. Further excavation in the center line near the north exposed a mass of human bones at a depth of only 18 inches. When cleared, this mass was found to cover a space only 3 feet from north to south and 4 feet from east to west. In depth the greatest concentration occurred at about 2 feet and below 3 feet 6 inches the soil was without mixture of any sort. There were four skulls, 2 complete mandibles (one very large and U-shaped), and a considerable number of long bones, ribs, pelvic bones, etc. The bones were a rich brown color and although badly broken, were of fairly firm texture. Pieces of male, female, and immature skeletons were noted. A few of the vertebrae and ribs showed signs of alignment, but in general no articulation of parts was indicated.

Intermixed with and also below the bones were a number of potsherds (including a few rim fragments) of the Nebraska culture ceramic type, all of which were almost identical with those from the Gates site. One flat knife blade of chipped stone (type?) had previously been found by Mr. Bishop. There were also fragments of burned stone and flint chips in the mixed area. The skulls and bones were taken for study by Dr. Poynter. There were no other bones below this deposit nor on any side so far as our excavations were extended. However, only about one-third of the "mound" was

excavated. Since this was the first time members of the Archeological Survey had observed human interments in association with potsherds of the Nebraska culture type, it seemed a noteworthy occasion.

“ MOUND ” 2

On our second visit, May 16, we trenched another elevation about 100 yards north of “ mound ” 1. “ Mound ” 2 consisted of a slight crest or rise on the narrow ridge, being about 45 feet from north to south and slightly less from east to west. Since its rise was continuous with that of the ridge, it was impossible to estimate accurately the height of the tip or “ mound ” apart from that of the ridge itself. A 3-foot trench 45 feet long was run through the center of the elevation from north to south. No artificial material was encountered except in a 3-foot area 9 feet from the north end of the mound. Here at a depth of only 10 inches a few human bones were found and these extended down to a depth of 2 feet 1 inch. Below this the clean sandy soil showed no evidence of any mixture. The trench at this point was carried to a depth of 4 feet and widened to 6 feet. The human bones consisted of an adult pelvic girdle with all the leg bones in place, an adult humerus, and above this the fragments of a child's skull with some other broken bones. The pelvic girdle and leg bones suggested the lower half of a flexed burial, but there was no trace of any of the rest of the skeleton or of the skull. Either the lower part of the body had been thrown into this shallow burial at a time when it was still held together by ligaments, or else the entire body had been buried here and the trunk and skull subsequently removed. Judging from the small size of the disturbed area, the former of these two explanations seems the most likely, especially since the great majority of the foot bones were likewise missing.

Two potsherds of the Nebraska culture type were found with the bones, also a fragment of a small shell pendant closely similar to those already figured from the Prairie Dog Creek ossuary (pl. 9, fig. 2, *i*), except that the Saunders site specimen has two incised lines just below the perforation. The pointed tip had been broken off and was missing.

A cross-section of the entire elevation (mound 2) gave no evidence that it was built up artificially; rather there was a more or less uniform layer of about 20 inches of dark moist soil over both the mound and the nearby ridge. Below this dark layer the soil was light-colored and sandy with numerous calcareous deposits. The bones had evidently been buried in a very shallow excavation in the upper part of the natural rise. No clearly defined pit could be discerned, however, since

the soil about the bones was very uniform in color and texture. Although our limited excavations in these mounds furnished no evidence that they were artificially built up, the fact that intrusive soil around the human remains could not be distinguished either complicates the problem. More thorough excavations, coupled with an examination by geologists or geographers to determine whether such sharp mounds as these can be natural, will be necessary to settle the question. This appears to be an unusually favorable site for such an investigation. [Since the above was written I am informed by Dr. E. H. Bell that these mounds and house pits have been almost entirely destroyed by relic hunters.]

HOUSE 1

The afternoon of May 16 and a considerable part of May 17 were spent partially excavating a house pit at the base of another elevation or "mound" some 50 yards south of "mound" 1. There were several large holes in this house pit, resulting from earlier relic-hunting activities. By a continuous series of 3-foot trenches we opened about three-fifths of the house, from 3 feet east of the center to just beyond the west end. In the center the floor area of the old lodge was 16 feet across and the fireplace (3 feet in diameter and four or five inches thick) was in the widest portion. A trench halfway across the house to the east indicated that the outline began to narrow slightly in this direction. To the west, all of which was uncovered, the floor area extended about 9 feet to the oval end of the house. Three feet west of the widest section the floor area had narrowed to 11 feet 6 inches, and in the next 4 feet it narrowed down still further to the rounded or oval end. Judging from the sections uncovered, the floor plan was ovoid, being 16 feet in greatest dimension from north to south and about 20 feet from east to west. The floor line seemed to rise at the ends and sides rather like the sides of a bowl, although time was lacking to work out this feature carefully.

In cross-section the excavations showed approximately 1 foot 4 inches of dark unmixed soil, then a layer of yellow soil intermixed with charcoal, a few artifacts and some debris which culminated at an average depth of 3 feet 3 inches in a rather well-marked floor line of baked clay, ash, and considerable charcoal. Just above this floor line considerable amounts of baked clay with twig and reed impressions were noted, as though the lower part of the roof had consisted of wattle and daub. No mixture was noted below the floor line in the central part of the house, although our examination was too cursory for any certainty. However, in the west end of the house

considerable mixture was noted to a depth of 4 feet 3 inches, or a little more than a foot below the floor line. Across the west end of the house, just on the floor layer, was a 3-inch charred beam which extended about 1 foot 6 inches beyond the north wall. Charcoal and burned clay were abundant on the floor and throughout the roof material above, indicating the burning of the lodge.

No posts or post molds, entrance passage, or cache pits were found, but, as already mentioned, our work was too hasty to give much value to such negative evidence. The artifacts found in the excavation all pertained to the Nebraska culture type. The pottery, which was fairly abundant, was unmistakably the same style as that from the Rock Bluffs and Gates villages. The gray-brown to brick-red coloring, grit temper, and the rather rare occurrence of almost obliterated cord markings are all similar. The rim sherds in most cases were identical; vertically perforated lugs, simple flaring lips with broad loop handles, flaring lips without handles, and scalloped and slightly incised rims were found. One thick rim with very deep scallops and the intervening "nipples" about one-half an inch long was rather unusual. This one sherd rather strongly suggests a type (pl. 9, fig. 1, *d*) from the Prairie Dog Creek ossuary and the Lost Creek region. Another rim sherd with a vertically perforated lug seems to show traces of flattened and partially eradicated quarter-inch coils on its inner surface. Nebraska culture pottery generally suggests the use of a paddle and anvil rather than a coiling technique. Otherwise the small series of rims recovered at the Saunders site would fit in perfectly with the series of rims from the Gates site.

One sandstone shaft polisher, two small finely chipped arrowpoints (one with three notches, NBa2; the other with 4, NBa4), with a few small end scrapers and side scrapers complete the list of artifacts from the house. All of the latter would fit in with either the Nebraska culture or the Lost Creek types. Animal bones, mostly broken and burned, were rather common. Elk and deer remains seemed most abundant, a burned and crumbly elk (?) skull fragment amidst a mass of wattle and daub material just above floor line being of interest. The shells of fresh-water mollusks were fairly common in the mixed layers. The presence of the above artifacts with the animal remains seems good evidence that the house had served for a dwelling at one time, whatever its final function may have been.

The most unusual feature of house 1, however, remains to be mentioned. This was the fact that there occurred at the floor level throughout the entire excavated portion of the house a great number of burned and broken human bones. These fragmentary bones were mixed with

animal bones, potsherds, stones, and artifacts, occurring on both sides of the fireplace and being especially numerous in the west end of the house. The bones were for the most part brown and very crumbly from charring, and various ages and both sexes were represented. Fragments of a half dozen adult and immature skull caps, leg bones broken in sections, isolated mandibles, and other bones occurred haphazardly over the floor. No evidence of regularly laid out or aligned skeletal parts could be distinguished. In the west end of the house these human bones occurred with other intrusive material to a depth of at least a foot below the apparent floor line.

The usual explanation for the occurrence of charred and broken human bones amidst other camp refuse, i. e., cannibalism, may of course be invoked. If so, it seems extremely peculiar that the local people would have left human jaws and skull fragments underfoot; or, assuming that conquering enemies had eaten the original occupants of the lodge prior to firing it, that they would have taken parts of their victims' bodies up and buried them in the "mounds". Considering the haphazard distribution of human skeletal remains in the "mounds" as well as on the house floor, it would seem more rational to regard house 1 as a charnel house of some sort connected with the burial rites of the local people. Perhaps bodies were stored here for the purpose of stripping the flesh from the bones prior to their ultimate disposal in ossuaries, a practice commonly reported for certain tribes of the Southeast. The evidences of residence in the house may have accumulated prior to its becoming a charnel house, or it may have served both purposes, however unpleasantly, at the same time. That some sort of ceremonial cannibalism may have been indulged in is, of course, quite possible, but it is hard to believe that the occurrence of so many human bones in this house was a mere by-product of culinary activity.

To my mind the situation here imperfectly revealed gives a glimpse into the nature of the burial complex of the Nebraska culture people rather than of the cannibalistic tendencies of either themselves or their enemies. Certain it is that when house 1 burned down, there were numerous human remains on the floor, but whether these were already ultimately disposed of in the house or whether they were awaiting transportation to the hilltop ossuaries at the time of the fire are questions that remain obscure. The Saunders site has a double interest, since it reveals suggestive evidence regarding the cult of the dead in the Nebraska culture and also in regard to the oval-shaped earth lodge which we partially excavated. Of the seven earth lodges pertaining to this culture partially or wholly excavated by the Survey

parties in 1930 and 1931, this was the only one that was not square or subrectangular in outline. It was also the only one to contain any large amount of human bones, although a few small fragments were noted in house 2, at Rock Bluffs.

May 17 was the last opportunity for field work during the spring of 1931, and our excavations were carefully filled up before leaving. The site had only been sampled, and much interesting work remained to be done. It may also be mentioned that besides the Nebraska culture remains briefly discussed herein, there are also said to be ash strata in the deeply cut creek banks to the south and east of the site. These should certainly be investigated. Moreover, the entire valley of the Elkhorn is terra incognita so far as the scientific archeologist is concerned. Through the efforts of enthusiastic amateurs such as J. B. O'Sullivan, of O'Neill, we know that there are numerous and extensive prehistoric sites to be investigated. This valley must always have been an important artery of communication between the northern and southern regions, since it is one of the few rivers cutting directly through the desolate sand hills district. Dakota raids against the Pawnee and vice versa passed through the Elkhorn Valley, and there are much earlier evidences of human occupation there which should be investigated.

THE WALKER GILMORE (STRATIFIED) SITE, CASS COUNTY

This is one of the most important as well as intrinsically interesting sites in Nebraska, and it may be added, in the Plains region generally. It is one of the very few stratified sites so far reported from the Plains or Upper Mississippi regions and is also remarkable for its topographical situation, extent, and type of cultural remains. Discovered by Walker Gilmore, son of Dr. G. H. Gilmore, the site was first worked by Dr. Fred H. Sterns, who has published a preliminary report on his findings (1915). In his unpublished report on the archeology of eastern Nebraska (1915 a) Sterns devotes considerable space to the site and gives a rather detailed map of deposits; hence in the following account we will only sketch in the general situation with such new data as have been obtained in some 10 rather brief visits to the place. It may be mentioned at the outset that in general we have found Sterns' conclusions adequate and well founded, and the major part of our work has been supplementary and confirmatory rather than original.

The older culture strata under discussion occur in a deep, narrow gully formed by an intermittent stream now called "Sterns Creek" by various local archeologists. This stream and the deposits are

located in eastern Cass County 8 miles south of the town of Platts-mouth and $1\frac{1}{2}$ miles south of the old river town of Rock Bluffs (maps, figs. 13, 24). Concerning the local topography, we may best quote from Sterns' brief but excellent summary report.⁷⁸

The lower portion of this stream's course [Sterns Creek] is through an alluvial terrace of the Missouri River. This terrace is now about a quarter of a mile wide and sufficiently raised above the present level of the river to be out of reach of even the highest water. It is separated from the flat through

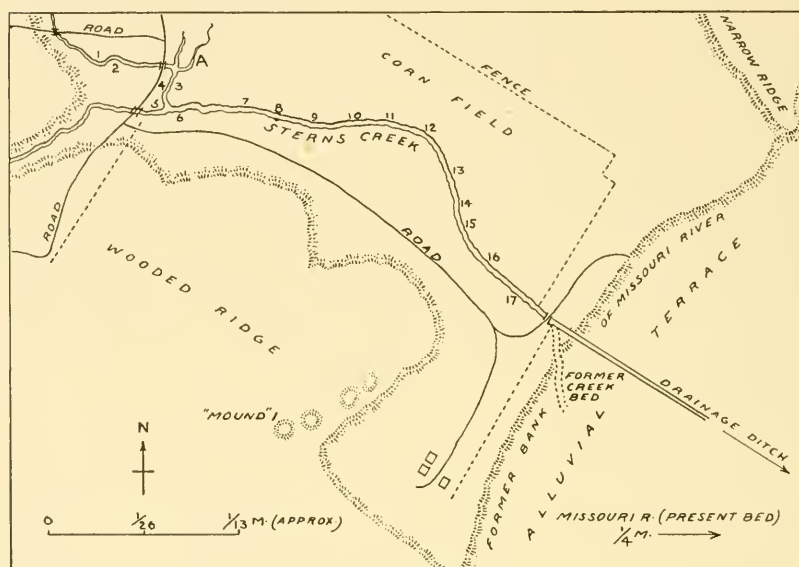

FIG. 24.—Sketch map of Walker Gilmore site, Cass County. 1-17, exposures of Sterns Creek culture; A, shallow exposure.

which the gully runs by an old river bank about 8 feet high. This flat forms an east-and-west gap between two high river bluffs to the north and to the south of it. Its greatest width from slope to slope is about a quarter of a mile.

The stream formerly had a winding southeasterly course across the alluvial terrace; but the owners of the property diverted the creek a few years ago by digging a drainage ditch almost due eastward. The great shortening of its course thus produced has caused it to cut the gully which it now occupies (pl. 19, fig. 2). This gully averages about 30 feet in width and 20 feet in depth and has almost vertical walls. In places its sides and bed are composed of a yellow loesslike clay similar to that which forms the neighboring river bluffs, while in other places it cuts through deposits of blue "gumbo" clay such as is common in the creek beds of the region, or through creek gravels, or through secondary

⁷⁸ 1915, pp. 122-123, Sterns' unpublished work, 1915 a, aside from a map and plates, showing exposures and artifacts, gives little additional information on this site.

loess such as could occur only as wash from the hills. The distribution of these various materials in the gully and for some distance in its banks (as determined by boring with a long auger) makes it clear that the present stream is cutting across the course of an older stream whose channel was wider than that of the present creek. The banks of the older stream valley had a much gentler slope than those of the present gully, and its course was not the same as that of the present stream. Where the latter cuts the old channel the gully walls consist of "gumbo" clay, gravel, or secondary loess. Where it does not cut the old valley the walls are of the original yellow clay.

The general situation above described is shown on a rough sketch map made by the present author, February 14, 1931 (fig. 24).

On the flats around the gully Sterns found numerous potsherds and a few flint implements. We will describe this pottery later, but for the present it will suffice to say that in the main it resembles the ceramic remains from the rectangular earth lodges (i. e., the Nebraska culture). As the flat has been plowed since 1857, at present no visible traces of house pits remain, but there was a remarkable concentration of pottery on the flat compared to its scarcity in the gully of Sterns Creek itself and its total absence on the surrounding ridges. These observations made by Sterns were corroborated by our own work here in 1930 and 1931. Hence he argues with reason that the rectangular-earth-lodge people dwelt on the flat itself and not on the ridges above. Since there is thus no evidence that the present surface cultural debris was washed down from the higher ground we can safely assume that the present surface of the flat on both sides of Sterns Creek represents the living level of the prehistoric rectangular-house people.

Coming to the gully of Sterns Creek itself, we find it to be generally straight-walled and, according to Sterns in 1915, averaging 20 feet in depth. It may be significant that our own measurements in 1931 showed a depth of 25 feet 6 inches at exposure 5 (map, fig. 24) and of 24 feet at exposure 8. Whether this actually represents an additional 4 feet 6 inches of cutting since 1915 can be determined only by detailed comparison of Sterns' data (1915 a, pp. 179-187) with a complete series of measurements taken at the points indicated in his description. However this may be, we may note that the cutting of Sterns Creek has exposed human habitation levels in the lower portions of the gully walls. Sterns notes that 4 feet below the present surface there are traces of charcoal but no artifacts. He points out that this may indicate casual human habitation at this level, but, judging from the very few scattered pieces of charcoal personally observed in the banks at about this depth, I would hesitate to go so far. Certainly there are no fireplaces and even very little charcoal;

hence it may equally well be the result of natural fires. Since there are no artifacts or hearths, the point has little immediate interest. Sterns goes on to show that 6 feet below this point (i. e., 10 feet below the present surface) there occur numerous ash beds and hearths. He distinguishes 17 such exposures of ash and 9 distinct hearths. It may be noted that our own sketch map (fig. 24) likewise indicates 17 exposures, but this correspondence must not be too strongly emphasized. Our own reconnaissance work was done in ignorance of the extent of Sterns' complete results and was therefore of a general rather than a detailed type.⁷⁶ Since there remains much important work still to be done at the site, some suggestions for a correlation of data and further research here will be given at the close of this section. The general distribution of the present exposures is indicated on the sketch map (fig. 24), but I strongly suspect that we have failed to locate some that Sterns mentions and added others of our own discovery.

Sterns describes two levels of habitation in the lower walls of the gully, one row of exposures at an average depth of 10 feet and at certain places another layer 2 feet below this group, the two strata being separated by a blue creek muck. This material accumulates rapidly and involves no great lapse of time between the upper and lower occupation levels. As the diagrams of the lower culture levels at exposures 4 and 10 (figs. 25, 26) indicate, we have found three levels of this older occupation at these particular places, whereas at other exposures, as Sterns noted previously, only one or two strata appear. Our own observations indicate a variation from one to three levels at the different exposures of this old cultural horizon rather than the one or two levels noted by Sterns. However, we are in agreement regarding the fact that cultural material from all these lower levels is uniform and that a relatively short period is represented by all three.

By using a long auger Sterns was able to demonstrate that these deep ash beds extend back into the gully walls on both sides for at least 50 feet. It thus appears that for at least one-eighth of a mile in a straight line along Sterns Creek there are some 17 old dwelling sites exposed and that similar hearths or dwellings extend back for some distance on each side of the gully. Since the exposure of sites

⁷⁶ Sterns' published summary (1915) was consulted in our work, but his complete manuscript and map (1915 a), being a thesis of which only one copy is on file in the Harvard University library, was not available. As already noted, it could not be consulted by the present author until January 1932, when his own work at the site had been completed.

by the recent cutting of Sterns Creek is haphazard and the present gully only cuts across the former stream bed at a limited number of places, it is evident that the early village or villages represented in the lower levels were rather extensive. Covered as this horizon is at present by many feet of alluvial fill, it has so far only been sampled by digging in from the gully walls. The prohibitive expense involved in removing the 10 to 15 feet of covering soil over the hearths has so far justified the easier but dangerous and unsatisfactory method of burrowing in from the sides. However, as will be mentioned later, there is a possibility that there are less deeply covered horizons of the same culture in the northwestern portion of the site (fig. 24, A). This possibility was discovered too late to be made use of in the present work, but if verified, may permit more systematic excavations in the future.

A discussion of the probable sequence of events affecting human occupation at the Walker Gilmore site may assist in understanding the foregoing description. From the available evidence it appears that the Missouri River at a former time flowed directly past the southeastern end of the small valley (see "former bank of the Missouri River," fig. 24). At this time another larger stream with a deeper bed and more sloping banks drained the valley and entered the river a quarter of a mile northwest of the present mouth of the Sterns Creek canal. The alluvial terrace and the relatively high ground level of the flat to the northeast (fig. 24) were then nonexistent. At this period the people of the lower levels built their houses along the banks of the old stream. Then the Missouri began to withdraw to the east, changing the gradient of the former stream, which accounts for the accumulations of creek muck over the earliest habitation levels. Apparently such floods were periodic at first, and the people came back to the same sites to settle when the waters had receded. In this way the one, two, or three levels of occupation separated by blue clay or black sandy soil are best accounted for (figs. 25, 26). Such flood deposits as occur between these lower levels are often so thin that the high waters of one or two wet seasons might account for them.

Finally, the stream bed became so clogged up that the flow was intermittent and the small valley began to fill through erosion from the surrounding hills. Living conditions were evidently unfavorable and the older population went elsewhere. Thus by the silting up of the old creek channel and the accompanying wash from the hills the present flat was built up and the lower alluvial terrace to the east extended out as the Missouri River shifted its bed in that direction. Unless the scattered charcoal in the redeposited loess from the sur-

rounding hills shall prove to be due to human agency, this was a period when the upper valley was generally uninhabited. With the formation of the present level of the upper valley and the resumption of drainage by the recent stream (Sterns Creek) the flat was reoccupied by another people, those of the "rectangular earth lodges" (Nebraska culture). How long they occupied the site or how many houses they may have had in the vicinity is uncertain, owing to still later changes. That they were entirely prehistoric is evidenced by the fact that in none of the very numerous Nebraska culture houses excavated in the past 20 years has any trace of Caucasian contact been encountered. Besides the remains clearly pertaining to the rectangular lodge dwellers of the Nebraska culture, a few other artifacts have been found on the surface of the flat which may be connected with still another culture. Hence we have at this place clear evidence of two distinct occupations—that of the Sterns Creek culture and later of the Nebraska and a related culture, all three groups being prehistoric.

With the coming of the whites the valley underwent still further changes. The flat was plowed and all surface evidence of the earth-lodge pits gradually destroyed, though the cultural debris from these sites still testifies to their former presence. Later the drainage ditch was dug directly east to the river (fig. 24) and with a shortened and direct drainage Sterns Creek began to cut down into the alluvial fill of the flat, thus forming the present deep, narrow gully. In this way portions of the deeply covered human habitation levels and small sections of the older stream bed were once more exposed. This is the history of the site so far as our present imperfect knowledge extends. Such an interpretation of the evidence adds little to that already presented by Sterns (1915), but has the value of corroboration based on independent observation and excavation.

NEBRASKA CULTURE (SURFACE DEPOSITS)

Since two definite levels of human occupation have been distinguished at the Walker Gilmore site, we will discuss the cultural evidence from each separately, taking up first the material recovered from the present ground level of the flat. Owing to the activity of Sterns and of local collectors since that time, the surface material in the plowed fields (see "corn field," fig. 24) is rather scarce. However, a rather brief time spent in surface collecting there in the spring of 1931 yielded 105 potsherds and a small amount of worked stone. In general this pottery was very uniform, save for certain exceptions

to be referred to shortly. Owing to long plowing, the sherds are all small, though they are quite adequate to establish their general type. The sherds are composed generally of a well-mixed paste with fine grit and in a few cases gravel used for tempering. They appear to have come from small or medium-sized vessels molded by the paddle and anvil rather than the coiling process. The ware is hard and in general seems to have a flaking rather than crumbling texture. The majority are smooth with some polish on the outer surface; only 22 (including two rim fragments) show partly eradicated cord-wrapped paddle marks. Ten sherds have a gray-white stain on the inner surface, which suggests a pseudoslip or chalky wash such as noted in the Rock Bluff Cemetery and Gates site pottery. The color is predominantly a light buff, ranging in a small number of cases to a dark red, evidently the result of variable firing. Much of the ware is blackish and smoke-stained from use. Of the 10 rim fragments recovered, 2 are slightly flaring and perfectly smooth, 4 are flaring with straight or diagonal tool marks on the outer edge of the lip, 1 rim is cord marked with diagonal incisions on the outer edge of the lip, and 1 is too battered for classification. The 2 other rim sherds are somewhat aberrant and will be referred to shortly. No lugs or handles occur in our collection, but this is probably due to the frequently repeated breakage and earlier collecting already referred to. Ten percent of the surface pottery collection made by Sterns had lugs. This entire series of sherds agrees very closely with the ceramic remains from rectangular earth lodges in the Rock Bluff Cemetery and Gates sites. This is in agreement with Sterns' conclusion regarding the bulk of the surface pottery fragments (1915 and 1915 a, II, p. 182).

However, in studying his surface material Sterns (1915 a, II, p. 182) came to the conclusion that a few of these sherds represented a somewhat different culture. These sherds, about four in number, were characterized by a marked collar which has heavily incised designs on it. These designs were either in the form of three or four horizontal lines below the rim or else simple patterns formed by incised horizontal and diagonal lines. In our own collection, gathered in 1931, are three sherds of this type. Two were found on the surface and one on a gravel bar in the bed of Sterns Creek. All these rim sherds, with one body sherd vertically marked with clear cord imprints, are out of the ceramic pattern of the Nebraska culture but closely approximate the pottery from the Lost Creek and Prairie Dog Creek sites on the Upper Republican River (pls. 5; 9, fig. 1). It would thus appear that in the surface occupation at the Walker Gilmore site there had been either some intimate contact of the two cultures or

else a successive occupation. In an addenda to his dissertation (1915 a, handwritten note at end of thesis) Sterns adds that, having at that time just examined some (protohistoric) Pawnee pottery, he thought these aberrant sherds from the surface of the Walker Gilmore site might be of Pawnee origin. This discussion would take us too far afield for present purposes but is introduced at this time to show our agreement with Sterns that although the bulk of the surface pottery from the Walker Gilmore site pertains to the Nebraska or "rectangular earth-lodge culture" (i. e., the Rock Bluff Cemetery and Gates site type), there is a small percentage which shows different affiliations.

Sterns mentions celts and shaft polishers from the surface, all of the "rectangular house culture" type. Dr. G. H. Gilmore found a fine polished grooved ax of hard green stone here some years ago (pl. 17, fig. 2, *b*). It has a flat butt and a smoothly polished but battered edge. The groove extends around three sides of the specimen, which is 12.5 cm long by 7.8 cm wide. The grooved ax is extremely rare in any of the cultures so far distinguished in Nebraska, and although such specimens are often found on the surface, they are not as yet diagnostic of any known horizon. Our own small surface collection, besides the pottery, contains little other than a few broken flint implements which are too fragmentary for classification. Summing up, the occupation of the present surface of the Walker Gilmore site by the Nebraska culture people is evidenced by the occurrence there of broken pottery fragments and a few other artifacts pertaining to this culture, besides a considerable amount of charcoal, broken bone, shell and stone fragments, all presumably turned up by the plow. So far no actual house pits have been located in the flat, although it seems quite possible that the lower levels of such house pits may still exist below the plow line. Judging from the not overly abundant cultural debris on the surface, I doubt that there were ever very many of these earth lodges on the flat, and locating them in cornfields plowed since 1857 would be extremely difficult.

DISPOSAL OF THE DEAD (NEBRASKA CULTURE?)

No positive evidence is on record concerning the mode of burial of either the Nebraska culture or the Sterns Creek culture people at the Walker Gilmore site. To the best of my knowledge no human remains have been found either on the surface or in the deep ash beds. However, on February 14, 1931, a series of four rather abrupt rises or "mounds" were noted on the sharp ridge to the southeast of Sterns Creek (fig. 24). The next week-end a pit was sunk in one

of these ("mound" 1, fig. 24), and at a depth of 3 feet 6 inches a human skull fragment was found. Work was stopped on account of rain, but on April 2 the excavation was continued. The "mound" consisted of an apparently natural rise or swelling about 45 feet long from north to south and 40 feet wide from east to west (pl. 20, fig. 1). Like the three similar "mounds" to the east, it was on the narrow top of the ridge bordering the river valley. Because of the slope of the ridge on both sides, it was impossible to determine its height, though there were slight depressions between the four elevations. A square excavation (pl. 20, fig. 2), 12 feet on a side, was made in the center of the mound to a depth of 5 feet 6 inches. Later four trenches were run from each corner in a NW., NE., SE., and SW. direction, and these were carried to the approximate edges of the slope. No soil distinctions indicating the building of an artificial mound were observed. Rather, there was a uniform surface layer averaging 1 foot 3 inches in thickness of dark humous soil; below this to a depth of approximately 4 feet the soil was of a light yellow color intermixed with scant human skeletal fragments and cultural debris; at the 4-foot depth limy concretions were abundant, and below this the soil was hard, unmixed yellow clay. The bones and cultural evidence were somewhat concentrated toward the center of the excavated area, but a few fragments occurred toward the edges of the pit and in the trenches.

In all, 12 fragments of human bone were recovered. These included an astragalus, a patulla, several rib fragments, fragments of long bones, and one portion of a zygomatic arch. One or two of the bones appeared to have been slightly burned. The cultural evidence consisted of a crude flint knife blade of small size, a flat retouched side scraper, and two crude end scrapers of the small planoconvex type. In addition two fragments of mussel shell, one lump of red burned clay, and flakes of flint and red quartzite were recovered. No potsherds were found. The small knife blade and the scrapers rather suggest the Nebraska culture, but lacking this type of pottery in the "mound", positive cultural identification is impossible. However, of the two cultures represented in the valley, a correlation between this burial site and the Nebraska or "rectangular earth-lodge culture" would seem the most probable.

It is difficult to decide what sort of interment is represented here. As stated, there were no indications that the site was an artificial mound. Rather it would appear as though one of the natural eminences on the ridge had been chosen for digging the pit in which fragmentary human remains had been disposed of. So fragmentary and scattered

were these human remains and so small in quantity that it is difficult to understand the occurrence. Probably this was an ossuary of the Nebraska culture in which previously exposed human bones were placed. The presence of the charred bones suggests that, since there is no evidence of any general cremation, possibly the ancient people themselves opened these ossuaries and took away the bulk of the bones when they moved away from the valley. Such an occurrence would explain the bone fragments that were left as well as the few artifacts with the dead. Time was lacking to open any of the other three "mounds" on the ridge and future investigation of these may clear up the problem. Similar ossuaries in apparently natural "mounds" near houses of the Nebraska culture and containing pottery of that type were found at the Saunders site near the mouth of the Elkhorn River in Douglas County, as described above. Hence the probability that the Nebraska culture people were responsible for this "ossuary" at the Walker Gilmore site is strengthened. Of the burials of the still older Sterns Creek culture peoples no evidence has yet come to light.

THE STERNS CREEK CULTURE (DEEP STRATA)

Since the cultural material from the lower strata in the gully of Sterns Creek is uniform and represents a type distinct from that in any prehistoric sites yet described, it may for the present be designated by the noncommittal term "Sterns Creek culture." In the following account an attempt is made to present all the available data bearing on the artifacts and mode of life of these early inhabitants of eastern Nebraska.

HABITATIONS

In his account of the lower ash beds at the Walker Gilmore site Sterns (1915, 1915 a, II, p. 187) only mentions finding fireplaces, rubbish heaps, and a few storage pits. He figures one such pit (1915 a, pl. 41) containing ash and stone fragments which extends from the upper stratum through the intervening blue clay into the lower ash level. No deliberate storage of materials in such pits has been noted; rather they contain refuse and occasionally broken artifacts. A somewhat similar pit from exposure 4 is illustrated here (fig. 25, A). Sterns makes no mention of either post molds or roofing material, hence it may be assumed that such evidence was not observed.

The general appearance of the ordinary ash strata may be seen in the illustration and diagrams (pl. 19, fig. 3; figs. 25, 26). In general these consist of an ash layer containing a definite hearth in the thickest

portion (figs. 25, 26). Away from the hearth the ash stratum thins out, though in a few cases it may continue on to another hearth (see 1, fig. 25, with fireplaces III and IV), as does also stratum 2 (fig. 26), which runs for 30 feet to the north, where it widens out into another fireplace. In general, however, one fireplace to a stratum (fig. 25, I) is usual. In some cases the gully of Sterns Creek passes directly through a habitation area, as is the case at exposure 8 (map, fig. 24). Here thin ash layers on both sides of the creek indicate that the central portion of the deposit has been washed away. The composition of these strata is mainly gray ash containing large numbers of calcined limestone fragments, wood, charcoal, animal bones, mollusk shells, and occasional potsherds and artifacts. The fireplaces or hearths are marked by a greater accumulation of ash and charcoal and an underlying lenticular stratum of baked clay (figs. 25, 26). Numerous

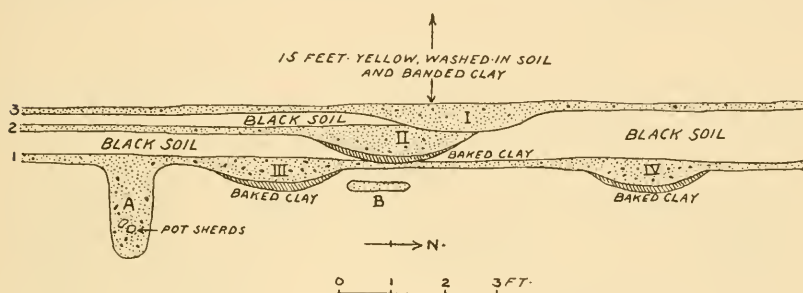

FIG. 25.—Ash strata and hearths at exposure 4, Sterns Creek culture, Walker Gilmore site.

stone fragments occur around and in these hearths, but no regular arrangement of such stones has been noted. Certain rather thick layers of ash are without any hearths and often contain masses of squash seeds, mussel shells, bones, and broken artifacts. These are probably refuse heaps. They occur on the same levels as the hearths but are usually located apart from them.

We were fortunate in finding more direct evidence as to the nature of the dwellings themselves than did Sterns. At exposure 10 (fig. 26) two post molds were noted in the intermediate stratum (2) and three post molds in the lower stratum (1). The upper molds were filled with the black sandy soil of the sterile area above the ash stratum. They averaged a little less than 3 inches in diameter and strongly suggest the refilled holes of posts in use during the occupation of stratum 2. The post molds in the lower stratum (1) were even more convincing, since the small eastern mold (fig. 26) contained charred wood, whereas the larger one 6 inches to the west was lined

with white ash, as though it had been dug out later and the surrounding ash had been filled in around the post. The inner core of this post mold was filled with dark soil. The post mold slightly more than a foot to the west contained brown pulpy wood fiber as well as the dark soil. Moreover, at the bottom the blue clay was compacted as though from pressure when the post was driven in. The filling of this "post" hole was very soft and could be cleaned out by brushing, leaving a firm round clay mold, and the impacted clay at the bottom could be scaled off. From west to east the circular post molds in stratum I were respectively 3, 4, and 3 inches in greatest diameter (fig. 26).

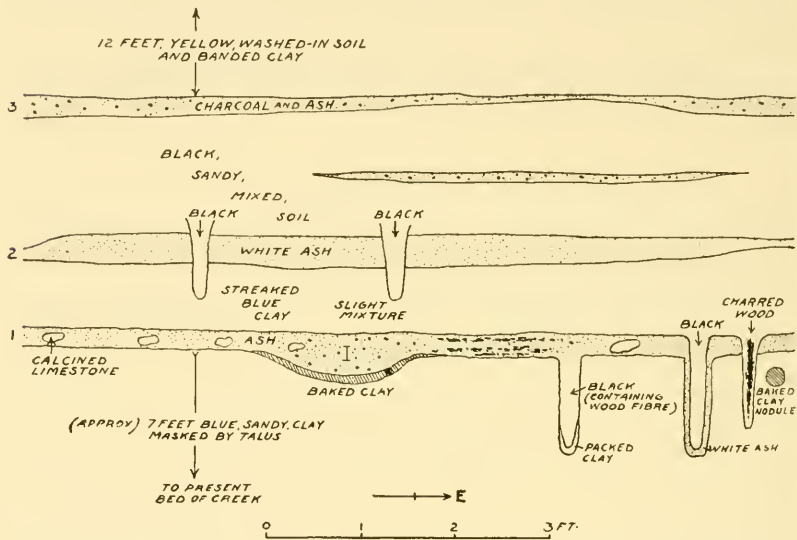

FIG. 26.—Ash strata, hearth, and post molds at exposure 10, Sterns Creek culture, Walker Gilmore site.

At exposure 5 a mass of what is thought to be reed roof thatch was observed on one of our last hurried trips to the site. As the two main forks of Sterns Creek come together at this place (map, fig. 24), there is considerable erosion during the rainy season and the material in question was thus exposed. Lack of time, combined with the muddy condition of the creek bed, prevented detailed work, but the general situation was clear. The ash strata at exposure 5 run along the north bank from the junction of the streams to a point about 25 feet west, where they terminate. On the west two stratum lines were visible, separated by blue clay, but near the junction to the east the lower stratum was deeply covered by talus fallen from above. The thatch layer, which was from 3 to 4 inches thick and extended for about

5 feet along the bank, lay directly above the upper ash stratum. It had evidently been preserved by the layers of blue creek muck which sealed it both from above and below. The reeds lay horizontally and had been pressed into a solid mass with puddled mud somewhat resembling bark. There was no evidence of the reeds having been woven into mats, although two small fragments of fiber string were found just below this layer. A large section of this thatch material was preserved, and samples were sent to Dr. Melvin R. Gilmore, who identified it as a large sedge (*Scirpus fluviatilis*). Below the layer of thatch and puddled mud was an ash layer and below this a blue creek muck which also contained various artifacts. How far back into the bank the reed layer continued was not determined. Conditions for the preservation of material were remarkable, owing apparently to the more rapid sealing up of the deposits in the blue muck. Besides the reeds, numerous fragments of wood, bark, nuts, and fragile bird bones were also recovered here. Owing to lack of time, however, this favorable circumstance could not be fully exploited. These fragmentary observations indicate that small poles or posts were used in the dwellings of the lower levels, that layers of large reeds were used for roof material, and that bark may have been employed for wall materials. Samples of the many pieces of bark obtained in the lower strata (especially at exposure 10) have been identified by Dr. Gilmore as that of the cottonwood (*Populus deltoides*) and the white elm (*Ulmus americana*). The exact nature and form of these dwellings remain to be determined, but to judge by the size of hearth areas and post molds, they were probably rather small. Such shelters differ in toto from all the later earth-lodge types in the region.

POTTERY

The ceramic remains from the deep strata are very uniform and differ markedly from any of the Nebraska ceramic types previously described. Pottery is not very abundant but occurs scattered through all of the deep ash layers. The following list indicates the amount recovered in our own work at the site.

Complete pots, 1 (found in gully at A, map, fig. 24, presented by

Dr. G. H. Gilmore).

Restored pots, 1.

Total number of sherds, 275 (rim 11, body 264).

Plain-ware sherds, 272 (rim 11, body 261).

Straw-marked sherds, 3.

Cord-marked sherds, none.

Incised body sherds, none.

Sherds with slip, none.

The texture of the Sterns Creek culture pottery is crumbly rather than flaky. It is fairly hard, however, and has a gritty, chalklike feeling. The tempering is of grit varying from coarse gravel to that of an almost imperceptible fineness. Tempering containing mica has been used in a considerable number of cases. The color ranges from a gray-black to a light yellow. Of the 264 body sherds, 50 are light-colored, 12 are intermediate, and 202 dark, the gray-black ware predominating. Surface finish is rough, only one sherd marked with fine vertical scratches showing any degree of polish. They have for the most part been smoothed inside and out, but the surface remains granular. Cord marking on the body is absent. Several sherds have the rough surface and vertical ridges observable on the complete pot found in the gully at A (pl. 19, fig. 1, *a*). Some such implement as a straw-wrapped paddle appears to have been used to produce this rough, vertically ridged exterior. On some of the sherds only traces of such ridges remain, owing to subsequent polishing. Straw-marked pottery is very much in the minority, however, as the above list indicates. Eight body sherds suggest in their horizontally ridged surfaces either the imperfect eradication of coils or else molding in a coiled basket. In the laboratory modeling clay pressed down into an open-mouthed coiled basket received much the same sort of ridges. In general this ware appears to have been coiled rather than molded by the paddle and anvil method. The vessels, to judge from the restored pots and other sherds, were characteristically small with a small mouth opening. From the degree of curve observable on the rim sherds Sterns estimated the average mouth opening to be 8 inches. This seems to me to be too large for an average. The scarcity of rim sherds generally (11 out of 275) argues for a small mouth opening, and this is borne out by the restored and the complete pots.

The inside of many of the sherds retain a thick black soot and all seem to have come from utilitarian vessels. There is considerable range in thickness from a few heavy, coarsely tempered pieces to very thin delicate sherds. The sherds range from 3 to 9 mm in thickness, with the thin ware predominant, and all seem to have come from small to medium-sized vessels. No trace of any lugs or handles has been encountered. All the 11 rim sherds in the present collection are decorated around the rim by a delicate thumb-nail scallop applied by what might be called a "pie-crust" technique or by simple incisions (pl. 19, fig. 1, *b*). This scalloped band is from 2 to 4 mm in width, and the impressions are applied diagonally or vertically, approaching but not crossing the lip of the vessel. Of the 43 rim sherds recovered by Sterns (1915 a, II, p. 187) from the deep strata, 40 had incisions

or finger-marked scallops, 1 had no rim decoration, and 2 were cord-marked on the rim. In spite of special efforts to obtain this last type in our own excavations, we were unsuccessful. The two cord-marked rims found by Sterns have five horizontal markings along the neck (each made with a single heavy twisted cord) and another similar group of five running diagonally down from the bottom horizontal line. What the complete design may have been or how far over the body the diagonal lines extended is uncertain, because of the small size of the sherds.

We were extremely fortunate in finding almost one-half of a pot intact in one of the hearths. This large fragment gave ample detail for an accurate reconstruction. Owing to the thinness of the ware and an accidental second breakage this was a difficult job, but it was successfully accomplished by C. B. Schultz. The specimen (pl. 19, fig. 1, *b*) brings out the main characteristics of the Sterns Creek culture pottery as suggested by the sherd collections. The characteristic delicately scalloped rim has already been noted. The absence of any sharp angle between neck and shoulder is also typical, as is the slight flare to the rim and the complete absence of any handles or lugs. The bottom tapers to a rounded point which, so far as our present evidence goes, is likewise characteristic. It is a simple, rather graceful vessel, quite unlike those from any other known culture in Nebraska. The restored pot is 16 cm high, 14 cm in greatest diameter, 9 cm across the mouth opening, and 5 mm in thickness near the rim. It is dark gray in color, agreeing in this regard with the majority of the other sherds.

Another complete pot presented to the Nebraska Archeological Survey by Dr. G. H. Gilmore evidently pertains to the Sterns Creek culture. This pot was found in the gully of Sterns Creek at the place marked A, figure 24, by a local farmer who gave it to Dr. Gilmore. It had apparently been washed out of the bank. Besides being unique among all hitherto known examples of Nebraska pottery, the specimen has many of the traits already mentioned as being characteristic of the deep-strata culture. It is small, has a slightly flaring lip, a gradual curve from shoulder to neck, and a rounded point at the bottom. The lack of handles and lugs is likewise suggestive. It differs from the usual run of deep-strata sherds in its rough barklike exterior which appears to have been the result of applying a straw or reed wrapped paddle. Its color is a buff or light brown. In the matter of color, surface texture, and plain rim it falls in with the minority of sherds recovered from the deep strata. The vessel is 6 mm thick at the neck, and the body is even thicker. This factor undoubtedly fav-

ored its preservation in complete form. The tempering is fine grit containing considerable mica. It is a small, compact little vessel 14 cm high, 10 cm in greatest diameter, and 8 cm across the neck opening. As will be brought out shortly, the old ground level rises at A (fig. 24) and typical Sterns Creek culture potsherds have been found in the gully walls at a depth of only 3 feet from the surface (pl. 19, fig. 4). There is every reason to believe, therefore, that the present complete pot was washed out of the same stratum and pertains to the same culture.

The only other pottery artifact recovered from the deep strata is a fragment of a tubular tobacco pipe (pl. 16, fig. 2, *i*). This specimen is made of hard, grit-tempered gray pottery and is conical, both ends being broken. It is 43 mm long with a diameter at the large end of 20 mm and of 11 mm at the small end. The conical section is transversely by a perfectly round 4-mm hole, which is blackened from use. There is no indication of any curve or elbow, and the complete artifact would appear to have been straight. Sterns (1915 a, II, p. 188) found three fragments of an identical type of pipe, including one which composed the entire upper part of the bowl.

WORK IN GROUND STONE

The most striking artifact of this type is the butt end of a small polished stone celt (pl. 17, fig. 2, *h*). It is broken and the blade is missing. The remaining portion measures 37 mm in length, 48 mm in width, and 26 mm in thickness. The hard stone has been carefully ground and shaped and the butt end is flat. There is no trace of any groove. Polished celts are not common in Nebraska (except as surface finds), and this is the only specimen of its kind from the deep strata. One hammerstone composed of burned limestone was recovered. It is 35 mm long and 30 mm across, having a cylindrical form. One end is heavily battered, and each side there is a pecked depression for grasping it. Another fragment of limestone with a flat polished surface and worn edges suggests a broken muller or grinding stone. Sandstone shaft polishers and paint stones, so common in the Nebraska culture, have not been reported from the deep strata of the Sterns Creek culture. Sterns mentions no ground stone artifacts from the lower strata.

WORK IN CHIPPED STONE

There are surprisingly few artifacts of this type known from the Sterns Creek culture, and these few are remarkable for their crudity. Sterns (1915 a, II, p. 188) found only two chipped flint arrowpoints.

one of the NBa2 (with two side and one basal notch) and the other of the NBc type. Both are rather crudely retouched and have a rather thick midrib. Sterns mentions no other chipped artifacts and reports that flint chips are rare in these lower strata. We found no arrow-points and few chipped artifacts of any kind. The largest of the latter is a crude "pick" broken at one end and roughly retouched to a point at the other (pl. 18, fig. 2, *e*). It is 18.5 cm long by 6.5 cm in greatest width and is of a very poor grade of chert. Its crudity and size give it a certain resemblance to the Chellean pick of the European paleolithic. Its function in the present culture is uncertain. The only other definite artifact of chipped stone recovered in our excavations was a rather crude "knife", 80 mm long, and retouched on one side (pl. 7, fig. 2, *f*). In addition, three crudely retouched flakes of gray flint were preserved. These may have been used as simple flake knives. Various flint and chert cores and flakes were noted, but, as Sterns states, they are relatively rare. Flint chipping was evidently of little importance in the Sterns Creek culture. This discrepancy in techniques is striking in a people who ground stone and made good pottery.

WORK IN BONE

Bone artifacts from the lower strata are very abundant and of good workmanship. Bone needles, rare or missing at most sites in Nebraska, are common here. Five of these are figured (pl. 18, fig. 2, *c, d, f, g, h*), as well as three broken points of ground bone (pl. 18, fig. 2, *l, m, n*) which may have been the pointed parts of needles or of plain awls. Two curved needles were found. The first of these (pl. 18, fig. 2, *c*) is unusual, since the fragments of the eye are on the larger end; also it is evenly notched along two edges. Whether these notches were decorative or of value in grasping the needle is uncertain. Certainly they would seem to have been of negative value in the matter of penetration. The other curved needle has a delicate eye, but the point is broken off (pl. 18, fig. 2, *f*). Like the above specimen, it is also made from the rib bone of a small animal but has been fire-hardened or tempered to a rich brown color. The two long, straight, complete needles (pl. 18, fig. 2, *d, g*) are respectively 140 and 130 mm in length. Both are fire-tempered and brown, but the lower specimen is made of bird bone, the upper of animal bone. The upper needle is therefore heavier and is decorated on one side by two sets of three diagonal notches. These may have served as ownership marks or as an aid in gripping the artifact. Besides those figured, one other butt end of a bird-bone needle and a section of brown, partly worked bird

bone were recovered. Sterns (1915 a, II, p. 188) found one notched rib needle, one plain rib needle, one ulna awl, and three rough bone punches. The types are generally similar to those just described.

We found one triangular piece of heat-tempered bison scapula, 96 mm long and 61 mm wide, that had been sharpened on the end and along one side. The worn-down end showed the most extensive use, whereas the sharpened edge seemed to be a secondary adaptation of a broken artifact. Its original use may have been as a digging tool, the broken part of which was later used as a scraper. Sterns found a similar broken scapula artifact. One heat-tempered bird bone head 55 mm long and 8 mm in diameter was recovered. Sterns also found one bird-bone bead. A unique artifact found in our excavation is a carefully perforated phalange of some medium-sized animal (pl. 18, fig. 2, *j*). The core at the large end has been removed to form a conical hole, and the small end has been neatly perforated by a small hole in the center. This gives every evidence of having served as the end cup of a "ring-and-pin" game (Culin, 1907, pp. 527-561). It is an interesting clue to the antiquity of this widespread game in the central plains.

WORK IN ANTLER

Four antler artifacts were recovered in our excavations. Sterns reports no artifacts of this material. Two of the above artifacts are deer or elk horn knapping tools. One of these (pl. 18, fig. 2, *i*) has been worn smooth by use and the tip of the tine has been ground down to a chisellike edge. The butt end is either broken or was severed by the original owner. From its size the material may be elk horn. A rather similar deer antler tine knapping tool, 14 cm in length, has a smaller but equally used point. Another fragmentary section of deer antler from which a side tine has been cut off suggests part of a similar flaking tool. Considering the small amount of chipped stone recovered, it is somewhat surprising to find as many knapping tools as finished flaked stone implements. Such a function, however, would seem to fit the antler artifacts in question, though of course they may have served some other purpose. One unusual deer antler tine "pick" is figured (pl. 18, fig. 2, *k*). This artifact has been cut off at one end to form a round butt. It is worn at the butt end as though formerly socketed and also shows extensive wear on the side where it curves up to the naturally pointed and little worn tip. Its function is problematical.

WORK IN SHELL

We found no shell artifacts, though numerous crumbly mollusk shells were encountered. Sterns (1915 a, II, p. 188) reports one piece of notched shell from the lower strata.

WORK IN WOOD

The abundance of elm and cottonwood bark, possibly the remains of house walls, has already been mentioned. Fragments of twigs were numerous, especially at exposure 10. Besides cottonwood and white elm, twigs, charcoal, and bark of either the bur oak (*Quercus macrocarpa*) or the white oak (*Quercus alba*) and twigs of the wild plum tree (the latter infested with "black knot") were identified. One worked piece of wood, round in cross-section and pointed, was also recovered there but subsequently lost. It was the size of an arrow shaft and may indicate the use of pointed wooden arrows with or without stone heads. At the same site a small worked piece of wood 90 mm long by 14 mm wide was recovered (pl. 18, fig. 2, o). The top of this fragment was fuzzy as the result of hammering, one end was cut off, and it had been cut in two, evidently with a stone tool. From its size and hammered top it suggests a skin-stretching peg. The other numerous wood fragments recovered showed no evidence of having been worked.

VEGETAL REMAINS

The most numerous plant remains in the deep strata were the seeds of the bush summer squash (*Cucurbita pepo* type *melopepo*) and those of the bottle gourd (*Cucurbita lagenaria*). Besides the seeds of this last species many small and large fragments of the gourd shell itself were encountered. These seeds and gourd shells were occasionally found in the hearths but were especially numerous in the refuse layers. In such deposits hundreds of seeds and gourd fragments occurred in large pockets. Sterns (1915 a, II, pp. 188-189) mentions the abundance of squash seeds, stating that one-third of all his material from the site consisted of these seeds. In identifying squash seeds of the same species from a historic Pawnee village, circa 1806, Dr. M. R. Gilmore⁷⁷ writes:

This type of *cucurbit* was of coextensive distribution with corn in the aboriginal agriculture of North America. In later prehistoric and historic cultures many tribes possessed *Cucurbita maxima* (winter squash), *Cucurbita pepo*

⁷⁷ Letter of April 10, 1931. All of these tree and plant identifications were made by Dr. M. R. Gilmore.

(pumpkin), and *Cucurbita pepo melopepo* (summer squash), but in earlier prehistoric cultures *Cucurbita maxima* and *Cucurbita pepo* might be lacking, [while] it appears that *Cucurbita pepo melopepo* was not lacking in any cultures which possessed corn and beans.

Neither Sterns nor our party found any trace of either corn or beans in the lower strata at this site. Considering the abundance of squash and gourd seeds, both charred and uncharred, it seems remarkable that neither corn nor bean remains were found. Perhaps future work here may reveal examples of these plants, but until this occurs the Sterns Creek culture must be listed as one having squash and gourds in abundance but no corn or beans.

Two species of nuts were recovered by us: the shells of the black walnut (*Juglans nigra*) and a few complete and fragmentary hickory nuts (*Carya minima*). One of the latter was stained a bright blue, which gradually faded on exposure to the air. This nut came from the blue creek muck under the upper occupation stratum at exposure 10, and I suspect that this blue color was due to some natural pigment in the clay. The thick masses of reed thatching composed of horizontally laid blades of a large sedge (*Scirpus fluviatilis*) have already been mentioned. In the puddled mud around and through this thatch, blades of bluestem grass (*Andropogon furcatus*) were distinguished by Dr. Gilmore. Careful work, especially in layers of blue creek muck which are so favorable to the preservation of perishable remains, will undoubtedly yield more evidence regarding both the wild and the cultivated plants used by the Sterns Creek culture people.

ANIMAL AND MOLLUSCAN REMAINS

Sterns (1915 a, II, p. 189) mentions finding the remains of deer, bison, elk, dog, small birds, and *Unio* shells, but no fish remains in the lower stratum. In our excavations we found deer remains were the most numerous, elk and bison rare, prong-horn antelope rare, great blue heron (two skulls in exposure 10), and many bird and small mammal bones. No fish remains were noticed. As already mentioned, detailed identifications were impossible. Two species of mollusks from the deep strata at the Walker Gilmore site were identified by Dr. Frank C. Baker. These are *Lampsilis ventricosa occideus* (Lea) and *Ligumia recta latissima* (Rafinesque). This does not complete the list of molluscan species present in the lower strata but only those that were included in the material sent to Dr. Baker. In general it appears that the Sterns Creek culture people depended to a considerable extent on horticulture, raising squash and gourds but not corn or beans,

at least so far as present evidence is concerned. Deer, small mammals, and birds were hunted, and fresh-water mollusks were used for food. Larger mammal remains, such as those of the bison, are extremely rare, and such animals seem to have been but little hunted.

PROBABLE ANTIQUITY OF THE STERNS CREEK CULTURE

Our later researches add very little to Sterns' conclusions regarding a tentative chronology for the cultures at this site. This matter of dating obviously calls for careful study by experts in matters of sedimentation and soil deposition. On two different occasions our party working at the site was accompanied by a field geologist and by a geographer, but their available time was too brief to form definite conclusions beyond confirming the general course of natural events already set forth.

Sterns (1915 a, II, p. 181; also 1915) pointed out the fact that box-elder trees of more than 10 feet in circumference now grow on the present level of the flat. He also found that in the streaked clay deposits just above the upper layer of the deep ash beds there were over 1,000 stratified bands. These bands appear to have been caused by very heavy rains, and as there are not more than two or three of these a year in this region we may have a clue to the time involved in building up the first 4 feet of deposits above the lower living levels. It may be added that above these deposits occurs some 6 feet of washed-in secondary loess and about a foot of black organic soil. Sterns concluded that 500 years would be a good minimum estimate of the time required for such an accumulation.

A historical approach to this problem rather tends to raise this estimate. To date, more than 40 houses pertaining to the Nebraska culture (i. e., Sterns "rectangular earth-lodge culture") have been opened without any traces of Caucasian contacts being discovered. If we take the date of Coronado's explorations in 1540-41 as the maximum date for the beginning of the historic period in this region, this gives the Nebraska culture a minimum date of almost 400 years. It may of course be much older than this, but it cannot be very much younger. Our recent discovery in the protohistoric Pawnee village at the Burkett site of glass beads apparently used prior to the acquisition of the horse shows that artifacts of white origin were traded or carried into Nebraska at a very early period. Hence, it seems to me, we are safe in assuming that the Nebraska culture flourished at a time prior to the Spanish or early French contacts. Therefore the occurrence of Nebraska culture remains on the present surface of the

flat at the Walker Gilmore site indicates an occupation at least 350 years ago. This, according to Sterns' minimum estimate, would allow only 150 years for all the physiographic changes involved in covering up the remains of the Sterns Creek culture with from 10 to 15 feet of stratified clay and redeposited loess. This is possible, but, it seems to me, rather improbable.

On the other hand, I do not presume to offer any other estimate. That set forth by Sterns has the undeniable virtue of conservatism and is founded on detailed observation by a man familiar with the local geology. Many a Nebraska farmer can tell of remarkable cases of rapid soil deposition observed during his own lifetime. Such examples of rapid erosion and corresponding soil accumulation are nearly always due to the breaking up of the prairie grass soil cover through plowing and the resulting rapid run-off. Such factors were absent in the prehistoric periods we are considering. However this may be, it appears that we can safely accept Sterns' minimum estimate.

SUGGESTIONS FOR FURTHER WORK

On our last visit to the Walker Gilmore site, April 2, 1931, Loren Eiseley made a discovery which may greatly facilitate the excavation of houses belonging to the Sterns Creek culture. Following up the north branch of Sterns Creek to the place marked A (map, fig. 24) he found several large fragments of Sterns Creek culture pottery projecting from the east bank at a depth from the surface of only 2 feet 8 inches (pl. 19, fig. 4). There was likewise a little scattered ash and charcoal at about this level. The lower soil here appeared from a hasty examination to be of the original clay rather than of recent sedimentary origin, and it seems the most probable explanation that the old soil level prevailing at the time of the Sterns Creek culture occupation rises at this place almost to the present surface. If this is so, trenching in this vicinity might reveal houses of the latter culture only 3 feet below the surface of the ground. It would therefore be possible to excavate some of these completely, revealing their form, the position of the posts, and all other details which are hopelessly obscured when burrowing into such strata under some 20 feet of overhanging bank. This may be too optimistic an interpretation, but it is hard to imagine how this type of pottery might occur in situ at such a place unless the level at which it occurs was at one time occupied by people of the Sterns Creek culture. Later people might have picked up the old pottery revealed by the cutting of Sterns Creek and dropped it on the higher ground where it was later covered up, but this seems rather improbable.

Not realizing how much still remained to be done at the Walker Gilmore site and having so many other areas and cultures in Nebraska to investigate, the University of Nebraska Archeological Survey from 1929 to 1931 made no very well-planned or extensive investigations there. Nevertheless, as the foregoing data indicate, we were able not only to verify Sterns' main conclusions but also to add considerable information concerning the site. At the present writing, having at last had access to Sterns' complete work and having combined it with our own results, the author feels in a position to offer a few suggestions regarding future work at the Walker Gilmore site. The fact that he should have put many of these into practice himself is freely admitted. It is always easier to advise than to perform.

First of all, the place calls for an extended period of cooperative research on the part of both anthropologists and geographers. It would therefore seem to be an unusually good project for the State university, where men of both these departments are already working together. The fact that it is only a few hours by motor from Lincoln makes it accessible for week-end field trips on the part of both students and research instructors. The entire site should be mapped and each exposure given a number. Sterns' practice of deeply incising this number on the gully wall above the strata seems very effective and prevents any mixup in referring to the different hearths or ash lenses. Meanwhile the course of the older stream as indicated by gravel and clay deposits could be mapped in by the geographers. Also the extent and relationship of the different types of soil would be diagramed. The combined results of such a survey would be an accurate series of maps showing the old dwelling places in relation to the former stream, to the various soil deposits, and to the present gully of Sterns Creek. It would undoubtedly be possible to obtain photostatic copies of Sterns' map and his photographs of the exposures as they appeared in 1915. These could be compared with the new maps and the rate of change in the local situation noted. The determination of the time period involved since the Sterns Creek culture deposits were covered over seems primarily a geographic problem. The actual age of surface trees and the clay banding noted by Sterns should be of primary assistance. It is worth noting that a large section of a tree about 10 inches in diameter was partially uncovered just above the thatch layer at exposure 10. This might give some indication of the time involved in the first filling of the old stream valley. Some system of tree ring computation might prove of great value, but the fact that the majority of trees in this immediate region seem to show little

seasonal variation in ring formation may complicate this method of attack.

From the archeological standpoint it is essential to excavate completely some of the houses and ash strata, working down from the top rather than in from the sides. This might be done easily if shallow deposits actually occur near A (map, fig. 24). If this lead proves futile it is still possible to pick an ash bed exposure over which some of the top soil has slid into the gully, leaving less earth to remove. It is always a great temptation to burrow into the exposed ash strata from the sides, but although such activities may yield a few interesting artifacts they cannot furnish such complete facts as are now urgently needed. A careful layer-by-layer excavation of a fairly large area would furnish data on the nature of the deposition, the extent and form of the houses, and would also yield artifacts in situ so that their relationship to the other cultural evidences might be apparent. This rather lengthy consideration of the possibilities of future work at the Walker Gilmore site is merited by the fact that could the strata be dated, a good chronology for two important prehistoric cultures in Nebraska would thereby be established. It should be borne in mind that this is one of the two stratified sites so far reported in the entire State. As the neighboring areas are worked, it will become even more important.

BURIAL MOUNDS AND NATIVE QUARRIES IN THE WEEPING WATER VALLEY, CASS COUNTY

The disputed matter of extensive aboriginal flint quarries occurring in the valley of Weeping Water Creek between the towns of Nehawka on the south and Weeping Water on the north has already been referred to. Owing to the general policy of the University of Nebraska Archeological Survey in 1929-1931 to work from the historic cultures back into the prehistoric horizons, no definite investigation of this problem was attempted. Since no undisputed artifacts had been found in any of the so-called quarry pits, and as any excavation there promised a great deal of work with scant results, the problem was neglected.

However, in November 1930 Dr. G. H. Gilmore called my attention to a series of apparently artificial mounds on the Weeping Water $3\frac{3}{4}$ miles northwest of Nehawka. A sketch map of this immediate region, furnished by Dr. Gilmore at that time and only slightly revised by myself, is presented here (fig. 27). It not only gives the location of the mounds in question but also indicates certain assumed quarry

pits and house sites as well.⁷⁸ Because of work then in progress at the Walker Gilmore site, little time was available for an investigation of the Weeping Water site; nevertheless, three short visits were made

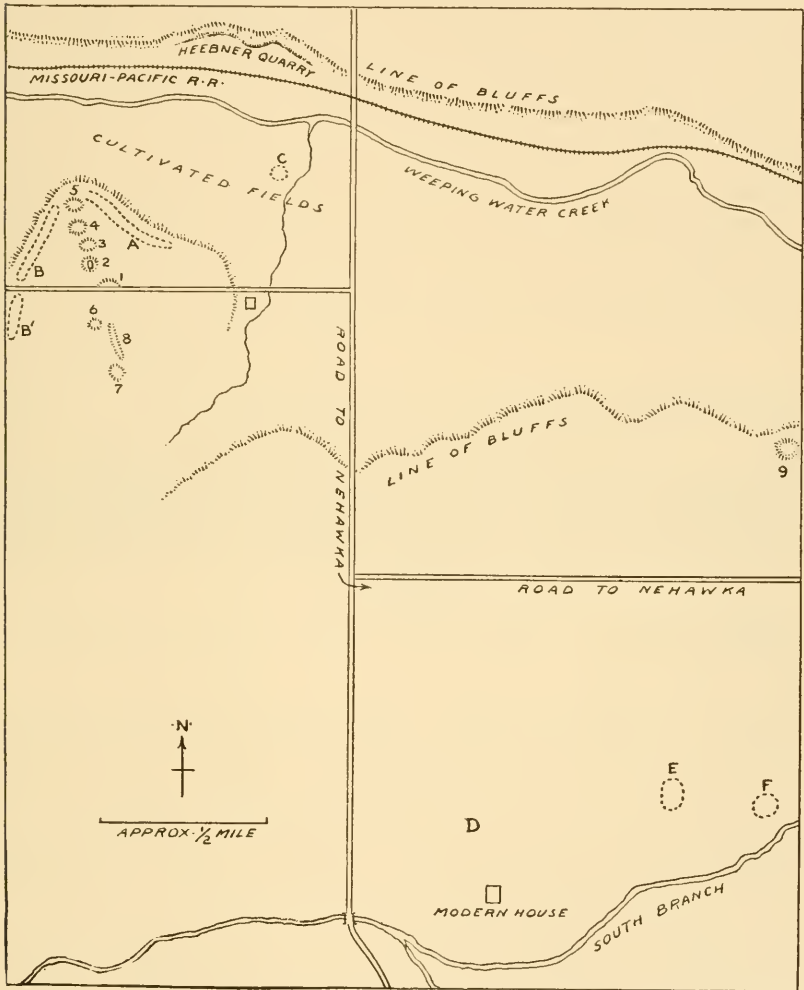

FIG. 27.—Sketch map of aboriginal sites on Weeping Water Creek, Cass County. 1-9, mounds; A, B, B', quarry trenches; C, E, F, house pits; D, where artifact figured (pl. 17, fig. 1, *b*) was found.

to the latter place on November 22, 1930, and on February 7 and 21, 1931, respectively. One mound was trenched and the region rather superficially examined on these three visits. In lieu of more extensive

⁷⁸ This is probably the hilltop site several miles north of Nehawka referred to by Todd, 1888, p. 375, and later by Blackman, 1907 *b*, p. 110.

work in such sites it seems worth while to record such data as were then obtained.

The point on which these mounds and quarries occur is slightly higher than the line of similar hills or bluffs bordering both sides of the Weeping Water on this part of its course. These bluffs rise rather sharply and in many places are marked just below their crest by apparently artificially formed trenches averaging perhaps 15 feet across and from 3 to 5 feet deep. These trenches now present a rounded concave surface shaped by long-continued wash from the surrounding banks. A typical surface section of one of these (trench A, fig. 27) is shown in pl. 20, fig. 3. The sharp banks of the creek here are heavily wooded, but the tops of the rolling hills are either only slightly brush-covered or else cultivated. As Dr. Gilmore's map (fig. 27) indicates, there are at least eight slight rises or mounds on

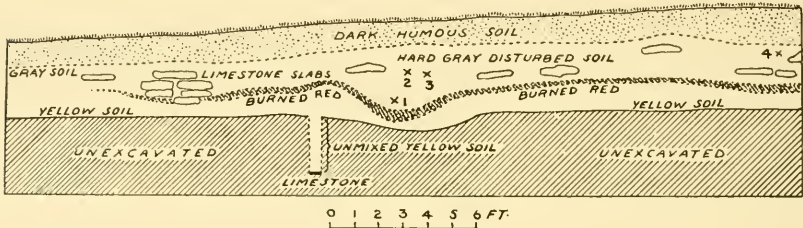

FIG. 28.—Cross-section, mound 2, Weeping Water Creek. 1, two fragmentary "bundle" burials; 2, flint knife or side scraper; 3, stemmed arrowpoint; 4, obsidian chip.

the point in question just back from the presumed quarry pits or trenches. The most northerly of these are covered at present by much-weathered slabs of limestone of all sizes, but two of the southerly mounds (1 and 2) are covered by soil and in a sparse thicket of oak trees. Mound 1 had been partially removed by the road builders, but mound 2 at the time of our first visit was untouched. The latter was an irregularly circular rise roughly 48 feet in diameter and 2 feet higher in the central portion than the surrounding level of the hilltop. The other mounds were even more irregular and less marked. Because of the rough terrain at the end of the point, it is hard to tell whether the northerly elevations are mounds or merely irregular rock piles resulting from earlier quarrying activities. They were not excavated.

Mound 2 (fig. 27) was the only one trenched, and the diagram (fig. 28) showing the west face of this excavation gives a cross-section of over half the mound. The surface was covered with from 12 to 17 inches of dark humous soil containing neither limestone slabs nor

artifacts. Below this occurred in sequence a stratum of hard gray mixed earth of variable thickness (fig. 28), a brick-red stratum of baked earth likewise varying in thickness, and a layer of apparently unmixed yellow soil extending to the underlying limestone bed rock. Two chipped stone artifacts, flakes of "Nehawka" flint, white quartzite or quartz crystal, and one flake of smoky black obsidian, besides some scattered charcoal, occurred in the hard gray mixed layer (fig. 28, 2, 3, 4). Numerous slabs of limestone, both large and small, occurred throughout this layer, some of these appearing in the cross-section figured. The baked soil stratum was thickest near the center and at a point about 3 feet south of the center underneath the fragmentary human skeletal remains. The latter occurred at a depth of 3 feet 6 inches and consisted of two very fragmentary adult skulls and various long bones (fig. 28, 1). These were extremely crumbly and rather suggested two bundle burials side by side, though not all the bones of both skeletons were present. The bones may have been subjected to the action of fire in some degree, but owing to their poor state of preservation, this could not be positively determined. No artifacts were directly associated with the human remains. A series of auger borings just south of the human bones struck the underlying limestone formation at a depth of only 6 feet 1 inch below the surface of the mound. The yellow soil below the burned area appeared to be unmixed with any artificial matter. Another interesting feature was a heap of large limestone slabs suggesting a cairn (fig. 28) 9 feet south of the human remains and extending to the east beyond the limits of the excavation. The 3-foot trench was widened at this point as well as in the vicinity of the burials. However, the slabs, when removed, appeared merely as an irregular heap over the thin burned stratum, and neither artifacts nor human remains were encountered. Possibly these may occur farther east than our excavation extended. Likewise, the thickness of the burned stratum near the center suggests similar deposits north of the limits of our trench in that direction. As indicated in the diagram (fig. 28), the burned stratum runs out just south of this rock pile, and there is no clear line of distinction here between the dark gray upper and the underlying yellow soil, which gradually blend together.

From the scant evidence at our disposal I am inclined to believe that mound 2 is of artificial origin. Although there are no clear lines of soil distinction between the mound proper and the old soil level, there is nevertheless the variable but extensive burned earth stratum which, so far as our limited excavation extended, underlies all signs of human activity. The human remains had been deposited on this stratum,

and the scanty artifacts occurred in the mixed gray earth above it. It therefore seems probable that this level was prepared for mortuary purposes by the building of extensive fires upon it, the removal of these fires and the placing of the human bones in the slight pit and, last of all, the heaping of earth and stone slabs over and around these remains.

The two definite artifacts from mound 2 are of interest. The first of these is a rather heavy stemmed point of gray "Nehawka" flint (pl. 7, fig. 1, *n*). In type it is slightly shouldered and definitely barbed with a convex base (SCB1), being the only point of this type found in situ during our excavations in eastern Nebraska (table 3), though it is similar to the predominant type in level II of Signal Butte (pl. 24, fig. 2, *e, f*). The other artifact is a small, oval, flaked knife or side scraper of the same material (pl. 7, fig. 2, *l*). As indicated in table 3, similar artifact types were found in house pit excavations at the Gates and Rock Bluff sites, in the Graham ossuary, and rather commonly at the Lost Creek site (see pl. 7, fig. 2, *k*). These correspondences, however, cannot be too heavily stressed, because of the simple type and widespread occurrence of this sort of artifact. The occurrence of one small flake of obsidian is interesting. Obsidian, so far as my personal observations extend, was noted solely at the surface sites on the Dismal River and at the stratified Signal Butte site near Scottsbluff. The finding of numerous flakes and fragments of the gray flecked "Nehawka" flint, in addition to the artifacts of this material, has a definite bearing on the larger problem concerning the utilization of the adjacent quarry pits, if such they prove to be. No pottery was observed in the entire excavation, though a careful watch was kept for any ceramic remains.

Conditions at mound 2 closely resemble those described by Gilder⁷⁹ at Long's Hill inasmuch as fragmentary human skeletal remains occurred in an apparently artificial mound and on a layer of baked clay. The Long's Hill findings differed, inasmuch as pottery fragments and artifacts (apparently of the Nebraska culture type) occurred with the burials above the burned clay stratum, while other scattered human remains were found at considerable depths below this stratum. So far as our excavations in mound 2 extended there were no human remains below the burned soil, but, as already indicated, more extensive work must be carried on here before this can be accepted as an established fact. The artifacts from mound 2 offer little evidence as to the cultural affiliations of the burials. The

⁷⁹ 1908, pp. 64, 65. Also footnote 1, p. 65, for a similar occurrence in Iowa.

chipped point is a unique type, whereas the small oval knife or side scraper finds analogues in both the Nebraska culture and in artifacts from prehistoric Republican River ossuaries and house sites. The fact that at Long's Hill Gilder (*ibid.*, p. 65) found similar burials with pottery and artifacts closely similar to those from the nearby Nebraska culture earth lodges suggests a possible affiliation with this culture.

Close to the mounds are the three almost continuous trenches or quarry pits shown in Dr. Gilmore's sketch map (fig. 27, A, B, B'), and there are other similar trenches (not indicated on the map) along the ridges both to the east and to the west. The present appearance of trench A (fig. 27) is shown in plate 20, figure 3. This section differs in its rounded, washed-in contours from trenches B and B', which have both bottom and sides covered with rough limestone slabs. As the underlying limestone almost reaches the surface all along these ridges the covering alluvial soil here is rather thin. According to Todd,⁸⁰ the limestone near Nehawka occurs in three separate strata, of which the middle stratum alone contains masses of flint. Whether such is the case at this northern site I do not know. Blackman has made a partial survey of the Nehawka "quarries" and reports 293 distinct pits, covering something over 14 acres⁸¹ in that immediate vicinity. He describes the flint nodules from the limestone near Nehawka as a unique type, being bluish gray in color and containing certain distinct fossils.⁸² It has a peculiar speckled appearance which, according to Woodruff (1906, p. 193), is due to the presence of small particles of opal in the flint. Although I cannot personally vouch for the restricted occurrence of this gray-blue speckled flint in the limestone of the Nehawka district, there is certainly an abundance of such material in practically all aboriginal sites in southeastern Nebraska. It is very common in prehistoric sites from Cass County, and throughout the present paper I have referred to it as "Nehawka" flint. The occurrence of artifacts and chips of this material in mound 2 has been mentioned, and similar chips and fragments were also noted in the assumed quarry trenches nearby.

The fact that Sterns, on the basis of personal investigation, does not believe that the so-called quarries near Nehawka are of human

⁸⁰ 1888, p. 375. Blackman, 1907 b, p. 104, makes a similar statement.

⁸¹ 1905, p. 3. Later, 1907 b, p. 104, he states that if the Nehawka mines were placed side by side it is estimated that they would extend 1 mile. One pit cross-sectioned was 10 feet deep and passed through three ledges of limestone rock.

⁸² 1905, p. 9, 1907 b, p. 104. Blackman also reports similar limestone and flint nodules from western Iowa.

origin has already been noted. This negative opinion is based on the fact that no aboriginal tools have been found in such pits, nor have any tool marks been observed on the limestone walls of such sites. He does not agree with earlier statements that certain exposed limestone areas show evidences of fire, and from the nature of the holes themselves and the rubbish accumulated in them he does not believe that they are quarry pits (1915 a, I, pp. 126-135). On the other hand, he offers no alternative explanation as to the manner in which such pits and trenches might have been formed through natural agencies.

Since I have not investigated this matter specifically, I cannot pretend to decide. However, from casual inspection of the northerly pits just described, I do not see how they could have originated in any other manner than through human activity. It is of course possible that the longer trenches and smaller pits might have resulted from the work of early white settlers seeking lime or stone for building or riprapping along the river. Woodruff states that during the early settlement small limekilns were constructed for local use at the base of steep hills and were charged with limestone from carts drawn by a single horse. In one season at Weeping Water the product of two such kilns amounted to 43,000 barrels. Such kilns were formerly employed between Weeping Water and Nehawka but went out of use many years ago. (E. G. Woodruff, 1906, pp. 209-211.) Although this possibility of a relatively recent white origin for the quarry pits must be considered, it seems rather unlikely in the face of statements that the earliest settlers in the region reported the pits as present when they first arrived. Bur oaks up to 15 inches in diameter also grow in many of the pits.⁸³

Moreover, if it be positively proved that the gray-blue speckled flint is characteristic of the limestone beds in this vicinity, the presence of artifacts of this material in the majority of prehistoric sites in southeastern Nebraska is a strong argument in favor of regarding these extensive pits as the source of such flint. Dr. Gilder is of the opinion that the Nehawka quarries are of native origin and believes that the trenches rather than the exposed limestone faces were mainly utilized in getting the flint. In this regard he makes the following interesting suggestion (communication from R. F. Gilder, November, 1930):

The hillside near the stream shows pits in the surface, around which is the material taken therefrom. I judge these pits to have been up to 20 or more feet in depth originally. It was from them the quarrymen obtained the nodules

⁸³ Todd, 1888, p. 374-375. Both Todd and Blackman, 1907 b, p. 108, mention such trees, the latter showing a photograph of one of them, lower photograph opposite p. 104.

for implement making, knowing that stone containing moisture was comparatively easy to shape as desired and that stone from exposed cliffs was difficult of shaping. As these pits are now nearly filled with material eroded from the hill higher up and decayed vegetation, those who first worked the quarry must have been there in the very dim past.

From their extent, and from the widespread use in prehistoric times of the peculiar type of flint said to come from this vicinity, the problem of the Nehawka flint quarries assumes considerable importance. When doubt has been removed concerning their prehistoric and aboriginal human origin, these quarries may rank with the "Spanish Diggings" of eastern Wyoming as one of the most important sources of native artifact material in the Plains area.

THE PROBLEM OF NEBRASKA MOUNDS

A problem in Nebraska archeology already touched on concerns the exact nature of the numerous "Indian mounds" reported from the eastern part of the State. Although it has been tacitly accepted by the majority of local field workers that these are of artificial origin, my own investigations lead me to question the universality of such a conclusion. A brief discussion of the ethnographic and archeological data bearing on this problem may serve to point the question.

The portion of Nebraska bordering on the Missouri River within historic times was occupied from north to south by the Omaha, Oto, and Missouri, with possible temporary incursions by other Siouan groups such as the Iowa and Kansa. According to Fletcher and La Flesche (1911), "mound burial was the common practice of the Omaha". The dead were buried in shallow graves in a sitting posture, facing east, under a pole framework which was covered with earth. A fire was kept burning for four nights at the grave. According to Bushnell (1927), Oto and Missouri burials were very similar, whereas Kansa graves in the earth were covered over with rocks. The heart of the State was occupied by the Pawnee tribes of Caddoan stock among whom individual inhumation in hilltop graves seems to have been an almost universal custom within historic times. An old photograph of heaps of sod over what are said to be Pawnee graves (Bushnell, 1927, pl. 36) is the only suggestion of mortuary mounds on record for this tribe, and recent archeological investigations in historic sites confirm the general absence of such structures (Wedel, no date). Since the other historic tribes occupied western portions of the State from which no mounds have been reported, they need not be considered here.

In addition to burial mounds, artificial structures of this sort may be erected as fortifications, ceremonial enclosures, substructures for temples or other buildings, and finally, may be the result of the gradual accumulation of mollusk shells or camp debris in kitchen middens or refuse heaps. Of these the second, third, and last types may be quickly dealt with. So far as the ethnographic data are concerned there is no historic record of either large ceremonial enclosures, mounds for temples, or earth substructures for buildings among any of the Nebraska tribes, a state of affairs so far confirmed by archeological research. Refuse heaps are the natural concomitants of all human habitations and occur in Nebraska as elsewhere. They have been particularly noted at certain protohistoric Pawnee villages (Blackman, 1907 a, 1924, and Wedel, no date). From the abundance of fresh-water mollusks at certain Nebraska sites it is possible that shell heaps may occur, but so far none have been reported. Since refuse heaps or middens are of such universal occurrence and differ markedly from the artificial earth or stone structures usually designated as mounds, we can eliminate them from the present discussion.

Although Bushnell (1922, p. 77) states that the Dhegiha division of Siouan tribes, which includes the Omaha, Ponca, Kansa, Quapaw, and Osage, were responsible for the great earthworks of southern Ohio and adjacent regions bordering the Ohio River, fortifications or ceremonial enclosures seem to have been largely lacking at historic Omaha and Ponca sites in Nebraska. Dorsey (1886, p. 220 and map 4), however, describes and figures a small "fort" near Ponca Creek on the old Ponca Reservation. No earthworks of this sort are mentioned in historic accounts of the Oto villages within the state (Bushnell, 1927). Blackman (1903) mentions clearly defined earthworks at the Oto site near Yutan, but neither Bradbury, who gives a description of the site in 1811, nor Irving, who does the same in 1833, mention this feature (Bradbury, 1817; Bushnell, 1927). Thus, while the Siouan tribes along the Missouri River in Nebraska raised burial mounds, they do not appear to have commonly erected earthworks either for purposes of defense or for ceremonial usage, nor have any extensive earthworks been recorded by archeologists within this region. According to Wedel (no date), nearly every Pawnee village of the nineteenth century was surrounded by earth or sod embankments. These have largely disappeared, owing to recent plowing, but are still visible at the Horse Creek Pawnee site in Nance County. Ceremonial enclosures, other than large earth lodges, are not recorded, but a circular embankment some 90 feet across at the historic Pawnee site near Linwood, Butler County, may indicate such usage. The

historic Pawnee sites of central Nebraska, although devoid of burial mounds, are (or were) marked by earthworks for defense and may have had a few small ceremonial enclosures. The ethnographic data, then, indicate that along the Missouri River strip occupied by sedentary Siouan tribes burial mounds would be expectable but larger earthworks generally lacking, whereas in central Nebraska the Pawnee were without true burial mounds but erected sod walls of circumvallation.

Coming to the archeological aspects of the problem, we have already quoted Clark's comments on burial mounds in southeastern and east-central Nebraska. To show that his conclusion concerning the artificial nature and mortuary purpose of the mound near the mouth of the Nemaha River was correct, we have already cited Zimmerman (1918). Sterns (1915 a) also concurs in this opinion. Shetrone (1930) states that the mounds of eastern Nebraska are "mostly low house mounds". The only confirmation I can find for this statement is the opinion of Jones (1892), who furnishes few specific data, and brief mention by Gilder (1907) of two low mounds north of Omaha containing hearths, some cultural debris, and both human and animal bones. Otherwise the recorded data overwhelmingly indicate that in eastern Nebraska the elevations or mounds contain human skeletal remains, whereas aboriginal house sites are marked by pits or depressions. We can thus for the present eliminate house mounds from the problem so far as the "mound area" of eastern Nebraska is concerned.

If the presence of human bones in marked elevations proved that the latter were artificial mounds, there would be no problem, for such occurrences are common. However, a mound artificially erected, when carefully excavated, should reveal soil differences between the base or natural ground level and the subsequently added material. It is in this regard that the Nebraska evidence is most contradictory or entirely lacking.

The discussion of the Long's Hill excavations pointed this out. All the investigators, Gilder, Osborn, Barbour, Hrdlička, Shimek, and Fowke, seem to agree that there was an artificial mound here, but aside from such statements there is little evidence on record by which a later investigator might form his own opinion. The occurrence of the baked earth strata reported by Gilder is the most convincing testimony in this regard; otherwise it would seem equally probable that a natural elevation on the crest of a ridge had been used for burial purposes over a long period of time. Gilder (1911 a) reports the excavation of 26 mounds in the immediate vicinity of Long's Hill, all apparently marked by a burned earth area on which the human

remains had been placed and then mounded over with earth. In addition, 60 different prehistoric bundle burials of a similar type are reported from both sides of the Missouri in this vicinity, and a skeleton associated with iron artifacts was also found under a burned clay area more than 3 feet below the surface near Ponca Creek (Gilder, 1908). The latter is said to have been an Omaha Indian. Gilder also reports many mounds associated with house pits near Child's Point and states that mounds occur from that place at approximately 100-yard intervals all the way to Omaha (1909). In the same report 20 burial mounds a mile south of Child's Point are said to have yielded, among other things, a considerable number of Spanish coins. Gilder regards these as being of Oto origin, presumably on the basis of Lewis and Clark's mention of an old Oto site in the general vicinity. Associated with the prehistoric house pits on Child's Point were five long narrow mounds, each 75 feet long and 25 feet wide, placed end to end. A trench across one of these revealed artifacts [of the Nebraska culture type] and human remains. About 300 yards distant was another low tumulus from which three mixed-up and calcined skeletons were recovered. The Wallace "mound" near Bellevue is also described as being 40 feet long by 15-20 feet in width and marked by a slight elevation on a ridge. Many dissociated and partly calcined bundle burials, 56 skulls (in three strata), and potsherds [apparently of the Nebraska culture type] were taken from this place (Gilder, 1909). Sterns, who was present during part of the excavation here, states that this was not a mound but rather a large number of intrusive burials on the side of a hill (1915 a). Gilder (1909) also mentions house mounds occurring at the site of the historic Omaha village in the forks of Papillion Creek, but, as previously mentioned, when I visited the site with him in 1930 we were unable to find either mounds or any definite traces of occupation.

Taken en masse, the above evidence would seem conclusive as to the erection of numerous artificial burial mounds in the Omaha region in both historic and prehistoric times. Personally, I am convinced that in many cases Gilder's conclusions are sound. Unfortunately, however, most of these extremely important investigations are recorded by a bare statement which, without detailed corroborative data, photographs, or diagrams, it is impossible to substantiate except by further work in the same area.

Blackman has also made certain mound investigations in Nebraska. He examined a reputed mound near Ruby, Nebr., in 1905 and decided that it was entirely natural in origin (1906). In the same report he speaks of numerous sharp conical elevations on the Iowa

side of the Missouri River. These contained burned human bones, but the mounds themselves, of which 200 can be seen from one place near Crescent City, are reported to be entirely of natural origin. Proudfit (1881) speaks of numerous mounds in southwestern Iowa along the Missouri River which contain human skeletal material and artifacts but show no soil differentiation when excavated. Proudfit evidently considers them to be of artificial origin. Blackman also examined a "mound" containing a post-Caucasian burial 5 feet deep (1907 a). He concludes that this was originally merely a burial 3 feet deep and that the 2 feet of sand had since been deposited on the bluff here. So far as reported, Blackman's data on prehistoric burial mounds is generally negative as regards the artificial origin of the mounds themselves.

Fowke mentions several burial mounds in northeastern Kansas and southeastern Nebraska (1922). He points out that the sandy loess soil of certain of these is identical with the surrounding soil but believes that at least certain of the mounds were artificially built up. The same conclusion is reached in regard to the artificial nature of the small burial mounds on Long's Hill. In this regard the following statement is significant (Fowke, 1922, pp. 158, 159):

The objection made to this theory [that the deepest bones from Long's Hill were in dug pits] is that the earth thrown out of the hole was unmixed, presenting throughout the appearance and consistency of loess as it occurs where exposed in ravines or on slopes in the vicinity. It is contended that if any previous excavation had been made here and filled up afterwards the mixed earth would be easily distinguished from that which was not removed, and that the line of demarcation would be easily discernible.

As a rule this is true; but when dry loose earth of homogeneous consistency is thrown out of a pit and then thrown in again without becoming mixed with any other, it is sometimes impossible to distinguish it at a later excavation. This is especially true of earth free from vegetable mold, as the soil in overflow lands which have been built up mainly from floods carrying uniform soil sediment. The line of demarcation between the dug and the undug earth in such conditions may become indistinguishable except when a vertical face is made which shall show a clear section of both in contact. . . . It is beyond question that any soil, humus, or other discolored matter thrown into an excavation with ordinary soil or subsoil will be apparent for an indefinite time afterward. But on some of these high points and ridges there is even now not a trace of soil. Frost and wind have worn bare spots where nothing grows or has grown for a long time. As this region was a prairie devoid of even brush when the whites settled here [sic], it is evident that such slight protection as grass or weeds afford would not be sufficient to hold the earth in place in winter, and when the ground is once swept bare such humble forms of growth may not get a foothold in future.

Later in the same work, referring to the puzzling "house mounds" of southeastern Missouri, he speaks of mounds without any evidences

of human occupation in which "no difference can be detected between the earth upon which the mound rests and that on either side. Yet the mounds are indubitably artificial." (Idem, p. 169.)

If Fowke's last assertions can be accepted, it becomes obvious that observable structural differences between an artificial mound and its natural base would not be expectable in certain parts of Nebraska or elsewhere in the mound area. However, the statement in the middle of the second paragraph quoted, that only a vertical cross-section would show such soil differences, is a very important qualification. How, otherwise than by a vertical cross-section, one might hope to distinguish between basal soil and artificial mound I do not know. As regards the "mounds" without a trace of human intrusive material which are "indubitably artificial" I can only express myself as being unconvinced pro or con. Fowke's assertions are interesting and should be carefully considered, especially in such peripheral mound regions as eastern Nebraska, but I do not believe that as yet they can be unqualifiedly accepted.

Sterns, as the result of his researches in southeastern Nebraska, came to the conclusion that true mounds are rare in that region (1915 a). Only three truly artificial mounds were encountered by him throughout the entire area. One was the mound mentioned by Lewis and Clark on the summit of a small hill above a branch of the Nemaha River, another was outside of Nebraska near Iowa Point in Doniphan County, Kans., and a third was a mile southeast of Nehawka, Cass County, Nebr. He states that many little (natural) elevations are mistaken for mounds and that (natural) hilltops are called "mounds" when they contain burials. He cites the Wallace "mound" near Bellevue as an example of this last type.

The researches of the University of Nebraska Archeological Survey from 1929 to 1931 already referred to, rather confirm Sterns' conclusions, though our own field work was mainly carried on in southern and central Nebraska, hence few "mounds" were encountered. In all, only four mounds were partially opened by our parties, and these incomplete excavations have been described in some detail. This work included cross trenches in two of the numerous elevations or "mounds" at the Saunders site near the mouth of the Elkhorn River, one fairly large central pit with four corner trenches in one of the mounds above the Walker Gilmore site near Rock Bluffs, and one mound cross-sectioned (out of the numerous mounds superficially observed) on Weeping Water Creek. Although all the mounds at the first two sites had the external appearance of being artificially raised in prehistoric times, none of those excavated gave internal

evidence of such a state of affairs. Lacking any direct evidence of human agency in their construction, I am inclined to believe that the bones and artifacts therein encountered were intrusive in natural hillocks rather than that the latter were erected for burial purposes. Here is a question, it seems to me, that the surface and soil geologist can help answer. If such mounds or hillocks cannot be accounted for by any natural agency known to have acted on the local topography, then, since they contain human material, they are probably the work of man. If natural agencies could have caused them, then I am inclined to regard their human contents as intrusive. On the other hand, such a site as mound 2 on Weeping Water Creek, which gives certain definite internal evidences of human construction, is in my opinion an artificial mound. Similarly, if the bare statements made by Gilder concerning numerous mounds near Omaha can be corroborated, these must also be included in the same category.

The problem of distinguishing intrusive burials in natural elevations from artificially erected burial mounds has, of course, a wider significance than merely its Nebraska aspect. Nebraska, like its neighboring States on both the north and the south, is peripheral to the great central mound areas of the Mississippi Valley, and such puzzling occurrences are expectable in border regions. Mound building was an activity indulged in by a great number of American Indian tribes over a great extent of time, and its various manifestations are complex. It is therefore important to understand clearly the mound-building activity on the borders of its distribution, where it occurs in its simpler and perhaps more rudimentary forms. Moreover, since there seems to have been a general exodus from the great mound areas of the east-central United States region at or just before the first period of white contact, it may be possible to trace the movements of such tribes up the great river valleys of the west. It has often been suggested that certain of the Siouan tribes were formerly located farther to the east and were responsible for many of the mounds of the Ohio region and elsewhere. This is not the place to consider such hypotheses, but it is not beside the point to recall that certain tribes of the Siouan group, notably the Oto, Omaha, and Ponca, came from the east into Nebraska about the time of the earliest white explorers and that others had probably preceded them in the region. Careful excavation of both true mounds and natural mounds used for burial purposes will undoubtedly establish a correlation between these and certain of the historic tribes already mentioned. As yet, however, I am not aware of one mound in Nebraska that has been entirely and painstakingly excavated in such a manner as to clearly set forth its details of construction and its cultural significance.

SURFACE SITES ON THE DISMAL RIVER, HOOKER COUNTY

According to Fletcher and La Flesche, the Omaha tribal hunting grounds extended "on the west to the country of the Padoucas, whose easterly village in the forks of the Dismal River, was known to the Omaha." This was evidently *Pa'-doⁿ-ka-noⁿ-ça-gaxa-i-ke*, "where the Padouca built breastworks".⁸⁴ Now "Padouca" is the Siouan name for the Comanche, a nomadic tribe belonging to the Shoshonean linguistic stock, originally neighbors and kinsmen of the Shoshone in Wyoming. They had already passed through Nebraska prior to 1804, for Lewis and Clark speak of the "Padouca Nation" as having formerly occupied the region to the west of the Pawnee and add, that although Bourgmont visited this tribe on the Kansas River in 1724, at the time of which they write even this southern portion of the old Padouca territory was held by the Kansa. How long the Comanche lived in central Nebraska is unknown, but the fact of their residence is testified to not only by the Omaha references quoted but also by the fact that the north fork of the Platte was known as late as 1805 as the Padouca fork.⁸⁵ In the course of the last 15 years A. T. Hill has made many trips into this Dismal River country, and although he has been unable to locate any village site exactly in the forks, he reported three camp sites in the vicinity marked by sparse but unique pottery remains.

In the summer of 1931 the author, on an archeological reconnaissance for the Bureau of American Ethnology,⁸⁶ visited the Dismal River forks on August 22-23 with A. T. Hill and members of the University of Nebraska Archeological Survey. The river at this point flows through the desolate sand hill region of west-central Nebraska before it joins the Middle Fork of the Loup in Blaine County (see map, fig. 1, sites 23, 24, 25). The forks are in a rough, almost uninhabited terrain of rolling hills which often attain a height of 100 feet or more. Although the underlying sand formation is largely held down by the abundant and characteristic bunch grass, there are occasional moving dunes and many blow-outs of varying size. Some hackberry thickets in the hill pockets, an abundance of yucca, sand-

⁸⁴ Twenty-seventh Ann. Rep. Bur. Amer. Ethnol., pp. 88, 91. The disputed identification of the term "Padouca" has already been discussed in the first section of the present paper.

⁸⁵ Bur. Amer. Ethnol., Bull. 30, pt. 1, p. 327. The south fork was also given this name up to 1819. See Grinnell, 1920, p. 249.

⁸⁶ Strong, 1932 a. This summary report includes a very brief discussion of the Dismal River sites and an illustration of the forks of that river, fig. 147, p. 154.

burs, and various small cactus plants give a rather southwestern appearance to the landscape. Both branches of the river flow through deep and narrow gorges which are marked by scattered bunches of bushy red cedars rare or lacking in the open country to the south. In the river canyon itself these trees reach considerable size, and old stumps 2 feet in diameter were noted on the south branch just above the forks. The narrow river bottom is thickly wooded with willow and cedar, and the water, although sandy, is cool and pleasant. In fact the river itself deserves a more cheerful name, for it is a refreshing and attractive oasis in a dismal country. Below the forks it is only about 30 feet wide and perhaps 2 feet deep with a fairly rapid current. It flows throughout the year and offers to man and beast the inevitable lure of fresh running water in an arid country. A mule deer was seen by members of the party, and birds and small mammals were abundant in the brushy areas. A large raccoon caught by the expedition's dog in a small gully furnished additional excitement. I have said that the country, first seen in a drizzling rain, was dismal, but this is only half true. The irregular contour of the sand hills, the rare cedar trees, and the wide vistas of unoccupied country have an allure of their own. It is still Indian country, though the natives have long been gone. One remembers the Dismal River and the sand hills with a thrill of pleasure, and plans to return.

We camped for two nights at the forks and spent a day in examining the region and in visiting two of the sites located by Mr. Hill. Between the north and south branches is a long ridge or hogback of considerable height. Deeply worn trails lead up the east end and the south side, and although these may be worn down by cattle, they suggest old Indian trails. A few tiny potsherds, numerous flint chips, and one beautifully chipped arrowpoint (type NBb1) were picked up on the east end of this ridge. There are no signs of any fortifications here, but a number of large blowholes some 30 feet or more deep and very wide offer splendid hiding places, and the ridge itself offers a wide view over both valleys. A few artifacts were found in the sandy areas along the south bank, but no concentration areas nor any occupation strata were noted, in spite of thorough searching.

One site (fig. 1, site 23) known to Mr. Hill is on the south bank 6 miles below the forks. This was not visited by our party. It is a large blown-out area of bare sand retaining evidences of old fires and originally marked by a considerable amount of broken pottery, artifacts, and chips. Mr. Hill reports that only the coarse, hole-tempered pottery is found at this site. Like the other two sites here, it has been rather thoroughly picked over by relic hunters from the nearest

towns. The next site upstream is only a few hundred yards south of the forks on the upper flat (fig. 1, site 24). Mr. Hill has recovered numerous artifacts and fragments of dark grit-tempered pottery from this site, but at the time of our visit nothing was found save flint chips. No hearths were observed here. It may be noted that at none of the three sites do lodge circles, house pits, or even fireplace stones occur.

We visited the third site in the afternoon. It is about 4 miles upstream and likewise on the south bank of the river. In size it is the largest of the three, and artifacts are scattered over a large irregular blowout of several acres (fig. 1, site 25). We recovered a considerable number of sherds of the dark grit-tempered ware, several conical "danglers" of trade copper, a few arrowpoints, crude end scrapers, and small pieces of smoky black obsidian. Mr. Hill has also found a few glass beads at this site, but we found none on this trip. Chipped stone is very abundant, with yellow and brown jasper predominating and "sugar quartzite" of "Spanish Diggings" type also abundant. Two hearths were noted here which consisted of a black crust from 1 to 3 inches thick and from 4 to 6 feet in irregular diameter. The sand had blown from around this packed and charcoal-impregnated soil, leaving it slightly higher than the surrounding level. Several smaller areas of this sort were noted. They occur in the places where artifacts are most numerous, but on their own surface are not marked by especial concentration. Careful slicing of this strata with a trowel yielded a few flint chips but no artifacts. The presumption is that these are the last remnants of hard-packed lodge or fire areas, the remainder of the camp having been drifted out, leaving the heavier debris concentrated by the removal of surface sand through wind action.

Such a camp area would presumably be gradually denuded of grass, so that on its abandonment the sandy soil would readily form a blowout. The narrow margin by which the grass cover holds down the sand is illustrated by the fact that although cattle are afforded good pasture here, when sheep were introduced in 1918, they ate the grass down to the roots and the soil blew away over large areas. Such a situation is characteristic of all three sites, and Mr. Hill has noted these harder-packed "hearth" areas at each of them. At the northwest edge of the upstream site is an area where the grass cover still holds, and here, running from the steep bank to the creek as though to encircle a considerable portion of the camp, is a slight irregular rise somewhat suggesting the remnant of an earth wall. We attempted to cross-section this to determine whether it might be artificial. However,

the uniform color of the sandy soil and the lack of time to dig an adequate trench prevented any positive determination. It may be that this is a remnant of the "breastworks" referred to by Omaha tradition, but further work will be needed to verify such a conclusion. There is, however, no doubt that there was a large camp at this site, and from the few trade artifacts found here it may have been early historic in time. Possibly the copper "danglers" and glass beads were left here by later Indians, but they occur intermixed with the aboriginal detritus. Shallow trenches penetrating the grass cover in this part of the site might reveal untouched hearths, but time was lacking for extensive work and our few trial pits yielded no evidence of this sort.

As already suggested, the pottery from these sites falls into two main types. The first of these comes entirely from the downstream site (D1), according to Mr. Hill. It is a very heavy ware, ranging from one-quarter to three-eighths of an inch in thickness and of a uniform grayish brown color (pl. 22, fig. 1, *a, b, c, e*). Both surface and cross-sections of these sherds show numerous holes, apparently where some sort of vegetable tempering has been burned out, and in this sense it is "hole-tempered". In addition there is much very fine white sand which probably also served for tempering. A very heavy vertical ridging occurs on the outer surface which suggests cord marking in general appearance but is more probably due to vertical pressure from a straw-wrapped paddle or perhaps by scratching with a pointed stick. Lack of twisted fiber impressions argues against the use of a cord-wrapped paddle. The vessels, to judge from the few rim sherds in Mr. Hill's collection, come to an abrupt edge and have no flare nor any sort of a shoulder or handles (pl. 22, fig. 1, *b, e*). The inner surface has been left smooth, but the lip is marked like the outside with triangular ridges succeeding each other around the rim. One or two of the rare rim fragments have smooth lips. The ware is surprisingly hard and light, though very thick and crumbly in appearance. One large rim sherd (pl. 22, fig. 1, *e*) shows a marked curve below the rim as though it were part of an open-mouthed round-bottomed bowl. This type of pottery is unique in Nebraska so far as my own observations extend, and it is very scarce even at this site. I have picked up sherds of this general type (thick "hole-" and sand-tempered, ridged on the outside and gray brown in color, but denser and heavier in composition of paste) at Kaighns Point on the south side of the Wildcat Hills in Scotts Bluff County about 12 miles south of Minatare, Nebr. Some of Renaud's sherds from surface sites in eastern Colorado also rather suggest this ware.⁵⁷ Its

⁵⁷ Renaud, E. B., 1931 a, plate p. 89.

affiliations are evidently with the west rather than the east, a circumstance which would be expected if this is actually Comanche pottery. The fact that, to the best of my knowledge, there are no historic references to Comanche pottery makes this an interesting point for future investigation.

The second type of ware found at the two upstream sites (D2 and 3) is similar in having fine sand tempering and mainly simple direct rims (pl. 22, fig. 1, *d, f-n*) but differs in lacking holes and in being very hard and smooth, both inside and out. The majority of these sherds are plain and well rubbed on the outer surface, but one especially (pl. 22, fig. 1, *n*) has marked crisscross ridges on the outer surface which have been partially eliminated by rubbing. One sherd in Mr. Hill's collection has a plain slightly flaring rim, one figured here has a broken rim of somewhat the same sort (pl. 22, fig. 1, *d*), and a third sherd with a plain enlarged rim has a diagonal groove across the flat lip (pl. 22, fig. 1, *f*). The color of this type of pottery ranges from a dull brown to a more common gray black. It is gritty to the touch. In general technique, tempering, and suggested shape the two types of pottery from these sites seem to show a relationship to one another. It may be added that in the same surface exposures at Kaighns Point, previously mentioned, thinner sherds of pottery closely similar to the type last described were found in association with the thick ridged fragments. During the excavations at Signal Butte in 1932, a number of the thin, sand-tempered sherds were found in the third or upper level (III) but none of the thick hole-tempered type.

Other artifact types seem to have been fairly uniform over all three sites, though all artifacts are rare at present, owing to long-continued surface collecting. Fortunately, Mr. Hill has a considerable collection from these sites, gathered during the last 15 years. The following description is based largely on his material. It should be added that the sites were apparently never rich, and artifacts are correspondingly rare. Retouched flakes of quartzite, perhaps used as side scrapers, are most common. A large number of these are exceedingly irregular, crude, and scantily retouched. End scrapers are of both large and small size and are crudely made. They are not very abundant. One diamond-shaped beveled knife of quartzite and three broken brown jasper awls or borers have been recovered. Arrow-points were fairly common some years ago. Small, delicate, double-notched points (NBa1) were most abundant, triple-notched points (NBa2) of the same fine technique were next in frequency, and triangular (NBa) and notched points (SC) were very rare. One frag-

ment of a sandstone shaft polisher and two flat mealing or rubbing stones (one 12 by 14 inches) have been recovered. Chips, cores, and rejects are abundant, brown quartzite, yellow and brown jasper and lesser amounts of smoky black obsidian being most noticeable. Bone work is rare, one large section of cut elk antler and a few fragmentary flint knappers of bone being the only artifacts of this sort in the Hill collection. The occasional occurrence of trade copper and glass beads has already been discussed. Such are the cultural evidences in these three sites on the Dismal River, and, whether they may ultimately be determined to pertain to the Comanche occupation or not, they are unique in many regards so far as other known Nebraska cultures are concerned. The sand hill region is not generally of great archeological promise, owing to its constantly shifting nature, but it must be remembered that the same wind which covers up last week's camp may uncover the hearths of a thousand years ago.

GRAVEL DEPOSIT CONTAINING ARTIFACTS AND FOSSILIZED BONES (BIRD CREEK CANYON SITE), SARPY COUNTY

On October 27, 1929, Dr. Robert L. Reynolds and the author, while searching for ancient burials along the high bluffs bordering the Platte River across from Ashland, found what appeared to be crude chipped stone artifacts in a gravel deposit covered by about 12 feet of yellow loess. This deposit occurs in the steep banks of a very small stream at a spot locally called Bird Creek Canyon (pl. 22, fig. 2, *a*). Bird Creek is intermittent, and its course extends a short distance west through the river bluffs and then turns south to flow across the bottoms into the Platte (see maps, figs. 1, site 34; 23). Located just east of that point in the Platte River where Saunders, Cass, and Sarpy Counties come together, the site is in the latter county about 2 miles east of the town of Ashland and 3 miles southwest of Gretna. The most noticeable topographic feature in the vicinity is the rather striking line of bald, high bluffs, between 1,100 and 1,200 feet in elevation, which extend in a northeasterly direction from the river. These are part of the same chain which continues to the south along the Platte just east of Ashland. Bird Creek is rather short, and after draining the higher country just behind the steep river bluffs, passes through a rather rugged little canyon to the flat, low river bottoms. This canyon is beautifully wooded, and the gravel deposit under discussion occurs in the creek bank between an eighth and a quarter of a mile east of where Bird Creek crosses the road at the foot of the bluffs.

Five visits (October 27, 1929, March 29, 30, 31, and April 1, 1930) were made to this site. On the last trip we were accompanied by

Dr. A. L. Lugin, of the Geology Department of the University of Nebraska, who made a careful geologic examination of the deposits.

The middle valley of the creek, i. e., Bird Creek Canyon, has been filled by many feet of loess washed in from above, and it is through this fill that it has cut down to its present bed. The gully walls in this section range from 5 to 30 feet in height but probably average about 15 feet in the canyon proper. Just above the point investigated by us the creek swings to the south against an outcrop of Dakota sandstone, then swings north and west out into the center of the narrow canyon. Here at a bend in the creek occur the covered gravel beds which are exposed on both sides of the stream. The best exposure is on the south bank, which is nearly vertical. A cross-section of the south bank at this place showed the following descending strata:

1. Dark organic soil, 1 foot (approximately).
2. Yellow washed-in loess, 11 feet.
3. Thin stratum of blue clay (perhaps an old soil layer), 6-12 inches.
4. Stratum of gravel, pebbles, and shale, 3 feet (containing bones and artifacts).
5. Blue and yellow clay, from this point down as far as was dug.
6. Total height of bank at this point, 16 feet (average).

Underlying the above deposits at varying depths are horizontal beds of Pennsylvanian limestone.

Excavations in stratum 4 were conducted by smoothing off a section of the gully wall (pl. 22, fig. 2, *a*) and troweling out the gravel, etc., for a depth of a foot or so back into the bank. This layer is composed of small rounded pebbles and gravel with small pockets of blue shale. The gravel contained numerous fragments and chips of ferruginous flint (pl. 22, fig. 2, *c*, *f*, *k*), nodules of flint with a limestone matrix (pl. 22, fig. 2, *b*, *d*), crude and broken retouched artifacts (pl. 22, fig. 2, *e*, *i*, *j*), and fragments of fossilized bone (pl. 22, fig. 2, *g*, *h*, *l-q*), some of which are burned (pl. 22, fig. 2, *n*). The great majority of the bones are small split fragments, most of which possess a rich brown patination. One bone fragment (pl. 22, fig. 2, *m*) shows the marks of some rodents gnawing and all are more or less fossilized. The above objects are scattered at random throughout the 3-foot gravel and shale stratum. Only two of the retouched pieces can be classified as definite artifacts. These are a delicately retouched side scraper with two sharp edges (pl. 22, fig. 2, *e*) and the butt end of a rather heavy dart, spear, or knife point (pl. 22, fig. 2, *j*). There are, however, large numbers of flakes suggesting crude artifacts but too irregular for classification. Many of the large flakes show no retouching of any sort and could have been caused by natural agencies. The majority of the flint nodules encrusted with a limestone

matrix have been rolled and worn smooth on their outer surface through water action. They range in size from small pebbles up to those a little larger than a man's fist.

The bone fragments, such as were large enough for identification, seemed to be mainly those of some species of bison. When compared with the remains of the modern bison and those of the extinct *Bison occidentalis*, they most closely resembled the latter in form, size, and degree of fossilization. Since no large or truly diagnostic parts were recovered, the identification is probable rather than absolute.

It may be added that the few artifacts recovered do not fit into any of the Nebraska cultures so far as known at present. This may be due to one of three causes: they may represent an earlier and hitherto unrecognized cultural horizon; they may merely be rejects left in the old creek strata by Indian flint workers attracted by the flint nodules; or they may simply be too fragmentary for any such classification.

Dr. Lugn, on the basis of an afternoon's examination of the creek bed and the gravel deposit, decided that the latter was not of Pleistocene age so far as its present position was concerned. Rather the deposits had been washed down from above and been left in their present position by later water action. The nodules of jasper had likewise been carried down from the limestone ledges above. The gravel itself might have come from original Pleistocene gravel beds in the upper reaches of the creek, but if so, there are no such beds exposed at the present time. The present creek has in the course of time cut through the washed-in mantle of loess down to the older clay and gravel beds. In so doing it has exposed the very old ledges of Dakota sandstone above the site, but so far as our examination extended it has not exposed any of the undisturbed Pleistocene gravels. The gravel deposit in which the artifacts and bones occur is therefore of the Recent period, but according to Dr. Lugn may still be of considerable antiquity. The depth of the cut and the occurrence of fossilized bones presumably of an extinct species argue for at least a moderate antiquity. Since the Pleistocene gravel beds in the vicinity are all covered at present with a thick mantle of loess, they cannot be examined. It is probable that the artifacts and burned bones were mixed in with the gravel during its period of redeposition. On the other hand it is possible that the artifacts and bones were in the original beds and were carried down along with the gravel itself. If this should prove to be the case, the mixed deposits would be highly significant. To judge from the unrolled condition of most of the bones and of the flaked stone fragments, it seems more probable that they are secondary additions to the gravel, although they occur all through and not merely on top of the 3-foot stratum.

As previously stated, the presence of the flint nodules may have led early people to use the gravel bed as a workshop site, which would account for the large amount of chips and flakes as well as the few broken artifacts. The fossilized bone fragments showing the effects of fire as well as the broken marrow bones (pl. 22, fig. 2, *n. g. q*) suggest that it was also a camp site and that these early people killed and ate bison of a species now extinct. The total absence of any pottery also indicates a nonceramic culture and in all probability a preceramic culture.

Owing to pressure of other work, nothing more was done in Bird Creek Canyon after our visit of April 1, 1930. The site here is very inadequately worked, and there are in all probability similar exposures in the bluff canyons bordering the Platte and the Missouri Rivers.

RECENT DISCOVERIES OF HUMAN ARTIFACTS ASSOCIATED WITH
EXTINCT MAMMALS IN NEBRASKA AND CLOSELY
ADJACENT REGIONS

Since 1929 several discoveries of human artifacts in association with skeletal remains of extinct animals, or under other circumstances suggesting some geologic antiquity, have been reported from within the boundaries of Nebraska. As individual papers have already been published concerning the majority of these finds, as well as two general reports (Strong, 1932 b, and Bell and Van Royen, 1934), they need only be briefly referred to here. Since this evidence, wherever authenticated, gives us the earliest glimpse of man in Nebraska yet known, it must be considered in a work such as the present one dealing with the general archeological problems of the State.

Considering these discoveries in chronological order, the first was made in July 1929 by C. B. Schultz, of the Nebraska State Museum, while excavating in the South Loup Valley about 7 miles southeast of the town of Cumro, Custer County (fig. 1, site 35). While removing fossilized bison bones from a 1-foot soil layer, under 16 feet of loess, Schultz found and removed a black flint point or knife blade. This specimen (pl. 7, fig. 1, *e*) is 7.6 cm in length and is of the so-called "Yuma type" (ND, fig. 7). Later, in September of the same year, I visited the site with Schultz, and we conducted further excavations but found no other artifacts. Schultz has published a brief account of the discovery. (Schultz, 1932; also see Strong, 1932 b, and Bell and Van Royen, 1934.) Owing to the premature removal of the artifact and the lack of secondary evidence, the association, although extremely probable, cannot be fully demonstrated.

In July 1931, while excavating fossil bison material on the bank of the Platte River near Grand Island, Hall County (fig. 1, site 36), Schultz (1932) found another chipped point in direct association with *Bison occidentalis* remains. Later it was learned that F. G. Meserve had found a similar point associated with the bison bones at this site in 1924. (Meserve and Barbour, 1932; Schultz, 1932; Barbour and Schultz, 1932 a; Strong, 1932 b; and Bell and Van Royen, 1934.) The artifacts are fairly well chipped points of blue-gray flint about 4.7 cm in length. Both are of NAb type, more or less transitional between NAb3 and 4 (fig. 7). The presence of numerous eye witnesses in both cases, the fact that Schultz photographed the last specimen in situ and preserved the mold from which it came, all tend to confirm the association as reported. As at the Cumro site, the exact geologic age of the deposit has not been definitely determined. (Bell and Van Royen, 1934, pp. 56, 58.)

In August 1931 A. M. Brooking, Director of the Hastings (Nebraska) Museum, reported the discovery of a chipped point in association with the remains of a fossil mammoth near Angus, Nuckolls County, Nebr. (fig. 1, site 38). (Hasting's Daily Tribune, August 20, 1931, and Figgins, 1931.) The point is crudely chipped from a blue-gray mineral and has a length of about 7.3 cm. Uneven longitudinal grooves occur on both sides, the tip is rather blunt, and the point is roughly of NAb2 type with a groove like NAb4 (fig. 7). Subsequent examination of the site from the geologic standpoint indicates that the fossil bones are apparently of Pleistocene age, possibly having been deposited during the second or Yarmouth interglacial stage (Strong, 1932 b, and Bell and Van Royen, 1934). Unfortunately, the evidence regarding the removal of the point is conflicting, and there exists no secondary evidence to confirm the association. This was pointed out shortly after the discovery (Strong, 1932 b), but as yet no explanation of the conflicting evidence nor any additional testimony regarding the exact nature of the association have been forthcoming. The matter is one of extreme importance, for if the actual association could be established beyond the realm of reasonable doubt, we would have here strong evidence of human activity during the mid-Pleistocene of North America.

A third and very interesting discovery of chipped artifacts in association with fossil bison remains was made by Schultz in the summer of 1932. While working out a large deposit of these bones occurring in the banks of Spring Creek near Signal Butte, Scotts Bluff County (fig. 1, site 37), Schultz encountered some eight chipped stone artifacts (Barbour and Schultz, 1932 b). The site was immediately visited

by E. H. Barbour and E. H. Bell, and the association definitely confirmed (see *Science News Letter* for August 20, 1932, pp. 118-119). The eight artifacts were found in direct association with the bison bones. The specimens have been well illustrated (Barbour and Schultz, 1932 b, p. 295, and Bell and Van Royen, 1934). Four are definite chipped points, one an end scraper, one a retouched fragment, and two are spalls or rejects. Of the chipped points, one is of "Yuma type" (N_{Da}, fig. 7), two are leaf-shaped without any longitudinal groove and are rather coarsely retouched. In each case the butt is broken, hence they cannot be more definitely classified; the fourth has a stem and shoulders (S_{Ca3}, fig. 7). The end scraper is planoconvex, being large and coarse. The two spalls are rather nondescript beyond appearing to be planoconvex. Barbour and Schultz (1932 b) have classified this material as of "a Pre-Folsom culture". The apparent cultural significance of these artifacts, and the others previously mentioned, will be discussed later. The geologic age of the deposit is not yet clear (Bell and Van Royen, 1934, pp. 61-62), although it is obviously of considerable age.⁸⁸

In the banks of the East Fork of Greenwood Creek, in Morrill County, about 10 miles northwest of the town of Dalton (fig. 1, site 39), Robert E. Cape in 1932 discovered several artifacts in deep, cemented sand and in gravel layers. The occurrence of certain of these chipped artifacts in situ has been observed and reported on by Bell and Van Royen (1934). The artifacts come from two levels, A and B. From A, the lowest gravel bed, come two retouched "scrapers" of planoconvex type evidently shaped by the percussion method and retouched by careless pressure flaking (Bell and Van Royen, 1934, p. 67). From B, the cemented sand layer above A, come two other planoconvex "scrapers", one of which is a definite end scraper. Both have apparently been worked by pressure technique. As to period, Bell and Van Royen tentatively suggest that gravel zone A may represent the cool and humid period represented in Iowa by the coniferous vegetation and that B might approximate the dry amaranth period in Iowa. (See Sears, 1932, p. 621.) They state (1934, p. 69):

We also do not know whether these climatic fluctuations, as indicated by Sears, were all of sufficient amplitude to find expression in the topography. If some of the fluctuations were of such brief duration that they did not result in

⁸⁸ Since the above was written A. L. Lugin (and C. B. Schultz), 1934, p. 355, has suggested that this site "seems to be not older than late Kansan, and it does not seem to be as late as Wisconsin. Apparently its age is late mid-Pleistocene, that is, post Kansan pre-Wisconsin." As will be indicated later, this startling conclusion seems rather at variance with the typological correlations of the artifacts recovered.

pronounced changes in the activity of the streams, the lower complexes of the exposure at Greenwood Creek might predate the oldest of Sears' periods. Such would very likely bring at least zone A into the youngest Pleistocene.

Before considering the cultural implications of the above discoveries two other recent finds in northeastern Colorado should be mentioned. In 1932, and again in 1933, single chipped points were found in association with mammoth remains at a site near Dent, Colorado. (Figgins, 1933.) The original discovery was made by Michael Ryan, Jr., and Father Conrad Bilgery, S. J., and the second artifact was observed *in situ* and photographed by Figgins (*ibid.*). The chipped flint blades are respectively 11.4 cm and 9.4 cm in length. One is leaf-shaped with a short longitudinal groove on both sides (NAb4, fig. 7), the other is longer and more triangular with a slight longitudinal groove on each side. (See illustrations, Figgins, 1933.) From their length they suggest knife or spear points. Partial remains of 12 individual mammoths were present, in the main representing young and small individuals. Figgins calls attention to the presence of numerous large boulders, which appear to be uncommon in the horizon, in association with the animal remains. The exact geologic age of the remains is uncertain, but Figgins believes that the terrace materials in which they occur must have been deposited by a vastly greater and older stream than the present South Platte River.

The most recent, and in many regards the most important excavation of this general type, was made by F. H. H. Roberts, Jr., of the Bureau of American Ethnology, in the region of Fort Collins, Colo., in October, 1934. (Roberts, 1935.) Guided by Maj. Roy G. Coffin and his brother Judge C. C. Coffin, who had found numerous Folsom points in the immediate vicinity, Roberts discovered remains of camp sites and workshops in a black soil stratum beneath some 14 feet of gravel and top soil. Numerous artifacts were found in association with camp debris such as storage pits, broken animal bones, and scattered charcoal. The findings at the Lindenmeier site included some 30 Folsom points (NAb4, fig. 7) (mostly broken), end scrapers, side scrapers, flake knives, stone drills with tiny points, and numerous small flake graters. Grinding stones, ground fragments of hematite, and a few bone artifacts were also recovered in the preliminary excavations. Particularly interesting are a number of planoconvex flakes that had been thrown off the otherwise completed Folsom type points. These indicate that Folsom type points were fully retouched on both sides and that the removal of the two longitudinal flakes was the last, and probably the most delicate, step in their production. The chipped stone artifacts show that it was largely a flake industry, and the majority of

artifacts are planoconvex in form. The majority of the points found in the preliminary excavations were of Folsom type (NAb4), and these range from very small to medium sizes. The only other type of point so far recovered are two small specimens without any groove (NAb2), both of which are thinned down at the butt end and one of which is largely planoconvex. The great importance of the find lies in the fact that there was here uncovered in situ a complex of artifact types extensive enough in range to merit for the first time the designation "Folsom culture". The nature of the associated fauna as well as the geologic horizon represented have not yet been determined. Work at the site has only begun, but the situation seems favorable for correlation with the glaciated regions and the terrace systems of the Platte drainage, hence there is a good chance of dating the horizon. Further work should also go far toward defining the Folsom culture (or aspect) in its major characteristics.

So far as geology is concerned, the clearest case seems to be the Angus deposit, which appears to be definitely Pleistocene (and probably mid-Pleistocene), but here the evidence of association is as yet very unsatisfactory. The rest, although extremely promising, await future geologic research. The second factor inhibiting cultural classification is the extremely limited amount of the human material found in such associations. In a later section such wider correlations as seem justified at the present time will be suggested. One important stratified site, that on the summit of Signal Butte, remains to be discussed.

SIGNAL BUTTE, A STRATIFIED SITE IN SCOTTS BLUFF COUNTY

In February 1931 the writer was informed by Thomas L. Green, of Scottsbluff, that stratified deposits of human origin occurred on the top of Signal Butte, a picturesque mesa (pl. 23, fig. 1) located about 21 miles southeast of the town of Scottsbluff (map, fig. 1, site 27). In August 1931, while on an archeological reconnaissance for the Bureau of American Ethnology, I visited the site, accompanied by members of the University of Nebraska Archeological Survey field party. We were under the guidance of Mr. Green. Test trenches were made at this time, which demonstrated the great importance of the site (Strong, 1932 a). In June and July, 1932, a Bureau of American Ethnology field party, assisted by four holders of archeological fellowships from the Laboratory of Anthropology at Santa Fe, conducted intensive excavations here under my direction. Permission to excavate was very kindly granted in behalf of the other owners by E. S. Simpson; Mr. and Mrs. Simpson were helpful in many other ways as well, and we

owe them a debt of gratitude. Throughout the work Thomas L. Green, the discoverer of the site, aided in every possible way, incurring both our professional and our warmest personal gratitude. Preliminary reports on this work have already been published. (Strong, 1932 a, 1933 a, b.) A complete report is being prepared by the present writer and Maurice E. Kirby (Signal Butte, A Stratified Site in Western Nebraska), but since this may not appear for some little time, a summary report on the site is included here. The great importance of the Signal Butte deposits lies in the fact that they offer a long stratified record of human activity in the extreme western portion of Nebraska. This, in conjunction with the stratification pointed out by Sterns at the Walker Gilmore site in the extreme eastern part of the State, forcibly introduces the all-important element of time perspective that to the present has been so lamentably lacking for major portions of central and eastern North America.

GEOLOGIC BACKGROUND

The general nature of Signal Butte has already been discussed and illustrated in the articles previously referred to (also see pl. 23, fig. 1). It may be added that it is a remnant of the old original surface of the high plains, is given an altitude of 4,583 feet on the United States Geological Survey map (Nebraska-Scottsbluff Quadrangle), and is located about one-fourth of a mile from Kiowa Creek and 14 miles southwest of the North Platte River. The base of the butte is composed of Brule clay (Oligocene), over this substratum rise almost sheer walls of the Gering formation (Miocene) which is capped by about 2 feet of white hard-grained rock of the same formation. The upper members of the Miocene formation are lacking at Signal Butte. Erosion has penetrated into and through this cap rock in certain places, up-ending slabs and producing some distortion. In and above this broken cap rock is a bed of sand averaging about 2 feet in thickness (fig. 29). From bottom to top there is a marked transition from coarse material to fine (based on mechanical analyses). Pebbles, more abundant toward the bottom than at the top, are composed mostly of slabby rock material from the Gering formation. Toward the top the bed grades rather abruptly into a light buff-colored silt deposit including some pebbles and quartz grains (fig. 29 and pl. 23, fig. 2). It is thought that this well-sorted detrital material is of Pleistocene age. This point, however, can only be established by full publication of the data obtained by Kirby.

The recent deposits on Signal Butte lying above this silt and gravel are composed mostly of materials weathered from the surrounding

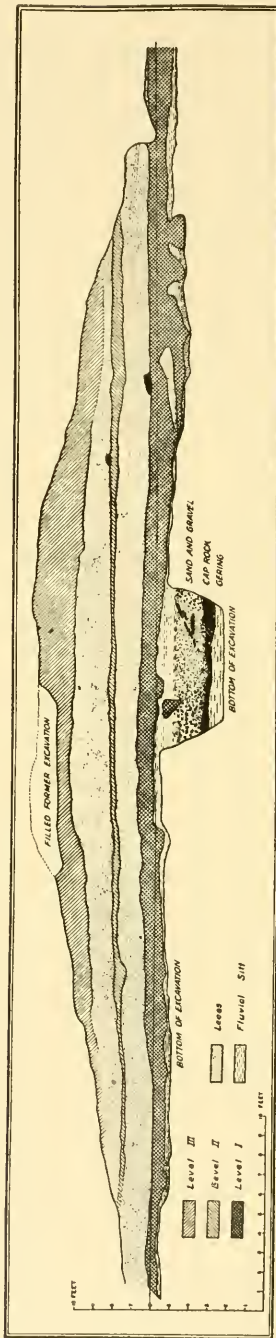

FIG. 29.—North to south cross-section through central portion of earth cap on top of Signal Butte. West face of row 1, showing three levels of occupation I-III. Much reduced. (Compare pl. 23, fig. 2.)

country rocks. These consist, on an average, of 8 feet of fine wind-borne material. Essentially, these may be called loess deposits, for analyses show their composition to be very similar to that of true loess found farther eastward. This loessial material is divided at intervals by three horizons of human cultural debris (numbered I-III from bottom to top). These intrusions represent old soil and living levels. The lowest cultural horizon, level I, lies directly on what are believed to be fluvial silts and gravels (fig. 29 and pl. 23, fig. 2). It is composed of loess similar to that of the rest of the aeolian portion of the earth cap impregnated with artificial matter, and contains humus to the extent that the horizon presents a sooty blackness. Some blackness may be attributable to burning, but a soil horizon is undoubtedly present. The horizon is so solidly cemented together by calcium carbonate that a shovel will not make much headway in it.

Above level I (fig. 29 and pl. 23, fig. 2) lies a $1\frac{1}{2}$ -foot horizon of sterile wind-borne material. Occupation of level I must have ended abruptly, as shown by the sharp transition into the sterile layer above. Above this sterile layer is a thin dark horizon (level II, fig. 29, pl. 23, fig. 2) about 6 inches thick. This horizon is darker than the sterile layers above and below, and it contains small amounts of rocks, bones, artifacts, and a few fireplaces. Level II is capped in the center by about 2 feet of sterile wind-borne material, and this in turn is covered by about $1\frac{1}{2}$ feet of soil containing artificial matter (level III). At the surface a vigorous growth of prairie grasses has darkened the soil to a depth of 3 or 4 inches. Level I lies in a flat plane, as does also level II some $2\frac{1}{2}$ feet above, but level III lies arched or draped over the present surface and, as a result, almost makes contact with level II at the edges of the deposit (fig. 29).

METHOD OF EXCAVATION

Before excavating, a topographic map was made of the butte by means of a plane table and telescopic alidade. The earth cap was contoured, using 1-foot intervals, the remainder of the butte was done in 10-foot intervals, and later a topographic map showing the 4 square miles around the butte, on a scale of 1,000 feet to an inch with 10-foot contour intervals, was made. The top of the butte was surveyed and staked off into 5-foot squares, and excavation proceeded on a 20-foot front from south to north. Later an east to west excavation was made, tying in with our original test trench. Every cross-section was mapped as exposed. The work was confined to the western half of the butte, the entire eastern half being left for future excavation and checking. The deposit was taken down layer by layer, according to squares, and

each layer was carefully cleaned off prior to excavation to prevent mixture of artifacts. All the material was screened. Near the edges of the butte the material from levels II and III could not be segregated with safety, because of the closeness with which they approached each other. This mixed material is not considered in this report. Before leaving the butte a lead pipe marking the datum point of our work, which was carved on it, was set in rocks and buried to aid future workers. We filled in our trenches and with Mr. Simpson's assistance made every effort to protect the site from vandalism. Our efforts unfortunately were largely unavailing, as the butte was immediately invaded by swarms of relic hunters, who have since destroyed much priceless evidence in the unexcavated area. Fortunately, we have a good record for one half of this unique and invaluable site, but it is tragic that mere curiosity and acquisitiveness on the part of a few individuals should be permitted to destroy a historical monument and scientific record which was truly an American heritage.

CULTURAL EVIDENCE BY LEVELS

In the upper sod and on the surface a few glass beads and objects of trade copper were found. Below the sod line no historic material was encountered. This top $1\frac{1}{2}$ feet, comprising level III of prehistoric human occupation, is not very clearly marked and gives evidence of sporadic rather than continuous occupation. Several fireplaces and a number of small storage pits containing a few potsherds and artifacts were encountered. One such pit contained the skull of a wolf and the mandible of a child. Several partial bundle burials in small, slab-lined cists, a few flexed child burials, and one complete skeleton of an adult male seated on a large rock were encountered in level III. Level II is indicated by a faint and rather thin black line representing a soil line and a brief occupational horizon (pl. 23, fig. 2, and fig. 29). Its artifact content is definite but very limited in extent, suggesting a uniform but sparse, and probably brief, occupation. It contains a number of shallow fire pits with blackened soil and charcoal. The charcoal from this level was pronounced to be juniper but proved unsuitable for dendrochronological determinations. Some of the fire pits were stone-lined. There were a few small storage pits on this level, and one contained a considerable amount of red hematite. Others contained broken up animal bones and a few artifacts. Level I is thick and black (pl. 23, fig. 3) and contained a great amount of cultural detritus and broken animal bones. Some of the latter are partially mineralized. On this level occur numerous small, pot-shaped storage pits dug down into the underlying silt and gravel. These were sometimes lined with rock

slabs and contained broken animal bones and a few artifacts. Shallow, round fire pits, occasionally lined with small stone slabs, were also numerous. No evidence of houses nor of postholes could be found, the people evidently living in the open or in skin tents which left no traces. No burials were encountered in either level II or level I, though one fragment of human bone was found in the lowest deposit (I).

CERAMICS

Pottery is confined entirely to the upper level (III). Not a sherd was found below this horizon. The ceramic remains fall into two main types, (A) thick with coarse gravel tempering, and (B) thin with sand tempering. Type A is similar in all essentials to that already described from Lost Creek and Medicine Creek (Upper Republican). Type B is identical with the thin gray-black pottery already described from surface sites on the Dismal River (Dismal River). Hence further detailed description is unnecessary here. No complete pieces were recovered. All sherds were preserved, 1,155 in all. Only 94 rim sherds were found, and these fall into the following types:

A. Upper Republican type (60 total).

a. Rim sherds with marked collar (20).

1. Collar decorated with closely spaced incised crisscross line (11).
2. Collar decorated with incised herring bone pattern (8).
3. Collar without decoration (1).

b. Rim sherds without collar (40).

1. Low, slightly flaring rim with swollen, incised lip (14).
2. Low, slightly flaring rim without incisions (23).
3. Direct rim with outside bevel (3).

B. Dismal River type (34 total).

1. Bowls with direct rim (12).
2. Low, slightly flaring rim with slightly swollen lip (22).

The majority of the sherds were small, and small vessels were apparently typical of both major types. A number of the Upper Republican sherds were bored for crack-lacing. The more numerous body sherds fall into the following classification:

A. Upper Republican type (total 747).

- a. Cord marked (649).
- b. Smooth outer surface (61).
- c. Red stained (or burned) inner surface (34).

B. Dismal River type (total 314).

- a. Sand tempered (314).

The occurrence of these two very distinct wares in level III apparently indicates that during this period the butte was occasionally

visited by at least two different groups. There is no blending or obvious relationship between the two ceramic types, nor was there any evidence of superimposition of either. The two ceramic types are illustrated (pl. 24, fig. 2, *a, b*; also compare pls. 5, 9, 21, 22).

GROUND STONE

Ground stone artifacts occur in all three levels. From level III come 13 irregular fragments of thin sandstone rubbing stones, worn on both sides (pl. 24, fig. 1, *y*). There are four nodules of sandstone used for abrasive purposes and seven shaft polishers, each with a single longitudinal groove. Three of the latter are rectangular, and four are irregular (pl. 24, fig. 1, *w, x*). The best specimen (pl. 24, fig. 1, *x*) suggests a type from level I. (Since it has probably always been impossible to gain the top of the butte without noticing the numerous artifacts where level I outcrops all around the edge, many of these ancient artifacts were picked up by the later peoples and used for their own purposes. In the same manner a few level II artifacts were evidently carried into level III. No distinct upper level types (II or III) occur in level I, but distinct level I types occur in varying proportions in the two upper levels). Level III also yielded 9 battered hammerstones (pl. 24, fig. 1, *aa*), all but 2 of which are broken, 5 pieces of polished hematite (pl. 24, fig. 1, *s*), 1 piece of iron oxide, and 2 fragments of a green mineral containing copper. The latter were obviously used as paints. Level II yielded one long oval lapstone, numerous irregular flat-sided grinding stones, ovoid and battered hammerstones, and some hematite. Level I, with its much greater artifact content, yielded several types of ground stone implements. These include numerous flat sandstone or pumice grinders of irregular shape (pl. 25, fig. 2, *l*); numerous rounded or natural pebble hammerstones (pl. 25, fig. 2, *i*); a number of pestlelike objects (pl. 25, fig. 2, *d*); two long, cylindrical, longitudinally grooved, shaft polishers (pl. 25, fig. 2, *j*); two broken grooved hammerstones or mauls (pl. 25, fig. 2, *o*), and a flat smooth quartzite ax battered on both edges and slightly notched or grooved at top and bottom (pl. 25, fig. 2, *m*). Both rough and ground pieces of hematite and limonite paint occur.

CHIPPED STONE

Chipped stone artifacts comprise the bulk of the Signal Butte collections, being especially numerous from the lowest occupation level (I). A wide range of materials is represented in all levels, with cherts, chalcedonies, quartzites, and jaspers predominating. Obsidian flakes

occur rarely in all levels. A few broken obsidian artifacts occur in level III. Chipped artifacts will be considered for each level, commencing with the uppermost and latest horizon (III). The statistics on the occurrence of chipped points, according to types and segregated by levels (I-III), is given in table 3 (p. 90). Since this distribution is one of the most significant as regards the stratification at the site, this table and diagram (fig. 7) should be carefully studied. In the illustrations (pls. 24, 25) an attempt has been made to figure all the types by levels roughly in the proportion of their occurrence.

From level III come 249 artifacts classified as chipped points. Small (average length about 2.5 cm) projectile points of a triangular, thin and delicately chipped type (NBa, table 3) are most numerous (80) (pl. 24, fig. 1, *h*). Next most abundant (53) is another small delicate form (NBa1) with two side notches and a straight base (pl. 24, fig. 1, *k*). A similar small type with a concave base (NBb1) supplements this last class (32) (pl. 24, fig. 1, *p*). These are typical upper level (III) arrowpoints, which preponderate numerically and do not occur save as aberrant forms in the lower levels. The sixteen NAb2 points from level III are larger and, in most cases, are typical of level I, where they were probably picked up by level III people. The same is true generally of the eight NAb1 and the four NAb3 type points from level III (pl. 24, fig. 1, *o, n*). Similarly, the three SCb2 and the three SCb3 points (pl. 24, fig. 1, *l, m*) are of the characteristic level II type and probably originated there, being carried into level III by the later peoples. The other small types scantily represented in level III (table 3) are numerically insignificant. The large ovoid type (NE) is really a side scraper (pl. 24, fig. 1, *e*) of irregular but generally ovoid form. There are 39 NE artifacts from level III. Some of these may have been carried up from the lower levels.

A characteristic level III type is the beveled, diamond-shaped knife (pl. 24, fig. 1, *f*). There are five specimens of this type (NCa), all from level III. Much more abundant (78) are planoconvex flake knives (pl. 24, fig. 1, *b*). These range from large (11 cm long) planoconvex types with one side carefully retouched, to small (2 cm long) flakes with merely a use retouch. The majority of these pieces look suspiciously like those from level I, with the same wide range of minerals represented and the small, abrupt retouch on the sides. Level III yielded 62 planoconvex end scrapers, the majority being rather large (pl. 24, fig. 1, *c, d*). Of these, 42 have the back retouched, 15 are rough, and 5 are retouched and stemmed. The preponderance in level III of ovoid, planoconvex, end scrapers with a neatly retouched back (pl. 24, fig. 1, *c*) is undoubtedly significant. However, all the stemmed

and a number of the other types were probably made in level I times. Side scrapers are rather abundant; there are 77 of planoconvex type (pl. 24, fig. 1, *a*). (The distinction between a planoconvex flake knife and the same type of scraper is in the edge. If the edge is thin and sharp the artifact is called a knife; if abrupt and blunt, a scraper. Naturally the choice in some cases must be arbitrary, but in general the types are distinct.) There are 39 side scrapers (NE) retouched on both faces (pl. 24, fig. 1, *e*). A number of both of these types are probably from level I. Many are broken, and some of the large double-faced scrapers may have served as chipped celts. Stone drills and gravers include 26 artifacts. Of these, 9 are triangular and retouched on both faces (pl. 24, fig. 1, *g*); 14 are unifaced gravers, in some cases suspiciously like those from level I (compare pls. 24, fig. 1, *j* and 25, fig. 1, *t*); the same is also true of three flakes with tiny retouched points (pl. 24, fig. 1, *i*). In addition to the above a large number of unclassifiable chipped fragments, flakes and cores come from level III.

The material from level II is limited. There are 73 chipped points, of which 29 are ovoid side scrapers (NE). The most abundant and typical projectile points from this level are stemmed (SC), of these, 17 have straight bases and barbs (SCb2) and 10 are without barbs (SCa2) (pl. 24, fig. 2, *e, f*.) The SCb2 points roughly average 3.5 cm in length and comprise the most distinctive artifact type from this horizon. There are 17 of the leaf-shaped type (NA), 10 of NAb2 and 7 of NAb1. A number of these leaf-shaped points are indubitably of level I type and were probably carried up by the level II people. From level II come 25 flake knives of medium to small size (pl. 24, fig. 2, *n*). The majority are mere flakes with retouched edges, and some were probably carried in from level I. There are 27 planoconvex end scrapers, of which 14 are more or less re-touched on the upper surface and 13 are without any retouching on the top (pl. 24, fig. 2, *j, m*). All are rather crudely worked, and there is a general similarity to the level I type, although the proportion of retouched to unretouched is higher. There are 60 small to medium-sized planoconvex, side scrapers (pl. 24, fig. 2, *l*). A few of these are of the neat, round, level I type with two plane surfaces and an abrupt edge. Some 29 side scrapers (NE) retouched on both sides come from this level (pl. 24, fig. 2, *k*). Many of these are irregular in shape. Several side scrapers are made of clear white and of rose quartz (pl. 24, fig. 2, *l* center). There are 19 stone drills and gravers, of which 9 are T-shaped, 2 are triangular (retouched on both sides), 2 are flakes with small points, and 6 are planoconvex gravers (pl. 24, fig. 2, *c, d, g*). In addition to the above,

numerous artifacts too broken for classification and chips come from this level.

A large number of chipped artifacts were recovered from level I. In all, 1,119 classifiable chipped points come from this level (table 3). The most abundant type are ovoid side scrapers (NE), which number 445; the remainder are knives (rare) or projectile points (common). The most characteristic and abundant of the latter types is a medium-sized (average length 4 cm) lanceolate or leaf-shaped projectile point with a concave base (NAb₃). The base is often thinned down by the removal of flakes from each face. These number 222 (pl. 25, fig. 1, *o*). A similar type with a horizontal base (NAb₂) is next in abundance (170) (pl. 25, fig. 1, *g*). Leaf-shaped points of similar size with rounded butts (NAb₁) number 45 (pl. 25, fig. 1, *f*). The majority of the above types are projectile points, but a number of larger-pointed knives are also represented (pl. 25, fig. 1, *g*). A type of stemmed point (SCa₂, 56, SCa₃, 87 and SCb₃, 47) is the main variant and here also those with a concave stem predominate (pl. 25, fig. 1, *b, c, d*). A rare thin, notched form (NBa₁, 2, and NBa₂, 29) (pl. 25, fig. 1, *c*) is unique. From the broad flangelike butt and the small rounded point it is difficult to guess what the purpose of this particular type may have been. This is the only notched form from level I, and they may represent an early and larger prototype of the small notched points of later times. The bulk of the other medium-sized points suggest arrowheads, but some of these, and the larger points, may have been used on darts. It is diagnostic of the level I culture particularly that in all types of points a considerable number occur that are definitely planoconvex (pl. 25, fig. 1, *d, right, f, left, o, right*). This feature occurs in the upper levels to a limited extent, but it is particularly marked in level I, where a number of the points are actually unifaced, retouched flakes having a decided fracture curve (pl. 25, fig. 1, *o, right*).

Next in abundance in the lowest level (I) are planoconvex end scrapers, which number 491. These fall into three main types: (a) those with an unretouched back, consisting of either a thick flake, or a split naturally rounded pebble with the end abruptly chipped (pl. 25, fig. 1, *s*). There are 290 of these, and they form a distinct subtype of this almost ubiquitous implement. The (b) type has the upper surface definitely retouched (pl. 25, fig. 1, *q*) and usually keel-shaped (153). The third and least numerous type (c) of which there are 48, has a definite stem, which in some cases has a concave base (pl. 25, fig. 1, *r*). As already mentioned, side scrapers, retouched on both sides and of an ovoid form (NE), are very numerous (445) (pl. 25, fig. 1, *v*). Some of the larger specimens of this type are

probably chipped celts (about 10) (pl. 25, fig. 2, *n*). Planoconvex side scrapers, both rounded and irregular in shape, number 217. The round, flat specimens with a fine, abrupt retouch are particularly characteristic (pl. 25, fig. 1, *u*). Flake knives, composed of large to small flakes used as cutting tools, number 277. They range from simple flakes with a use retouch along one edge (pl. 25, fig. 1, *y, z*) to definitely worked, planoconvex artifacts with a neatly retouched back and a thin, finely retouched edge (pl. 25, fig. 1, *w, x*). This last is a characteristic level I type. Chipped stone drills and graters number 124. Of these 52 are mere flakes, either plain or retouched on one side with a point on the end or projecting from one side (pl. 25, fig. 1, *n*). In eight cases this side point is very tiny, and a number of such artifacts may have been overlooked in sorting in the field. In general, the thin flakes with sharp, but graduated rather than abruptly shouldered points, can probably be regarded as graters for bone etching, etc., and the longer pointed types as drills or awls used for perforating skins prior to sewing. Almost equally numerous (50) are T-shaped drills with a carefully retouched point (pl. 25, fig. 1, *m*). Four drills have definite retouched stems, two having shoulders and a concave base (pl. 25, fig. 1, *k*). This is a widespread type. Some 18 drills are triangular in outline and more or less retouched on both sides (pl. 25, fig. 1, *p*).

There are a number of unusual chipped specimens, including a large stemmed knife characterized by beautiful chipping, a concave base, and a broad notched tip (pl. 25, fig. 1, *j*); a spurred knife with an unusual stem (pl. 25, fig. 1, *h*); and several spoke shaves (pl. 25, fig. 1, *l*). In general, it can be said that flint work in level I was in the nature of a flake industry, as demonstrated by the high percentage of occurrence of simple flakes with finely retouched edges as points, end scrapers, side scrapers, drills, graters, and knives. In addition to the abundant artifact types, level I yielded a mass of retouched fragments, flakes, and cores. It was obviously a workshop as well as a habitation horizon.

BONE AND ANTLER WORK

Artifacts of these materials are rather limited in all three levels and are not strikingly distinctive as to type. However, certain differences do occur. In level III, the following specimens were recovered: 4 knapping tools, 1 of ground down antler and 3 of split antler, all having rounded points (pl. 24, fig. 1, *u*); 1 short heavy punch of elk antler (pl. 24, fig. 1, *z*), 8 awls, 1 rounded and 7 of split bones or antler with sharp, rounded points (pl. 24, fig. 1, *t*), 2 of which are merely sharpened splinters of bone; 9 pieces of cut bone, 2 of which

(pl. 24, fig. 1, *r*) have rounded ends each with a single perforation; 1 piece of worked scapula (possibly part of a hoe); 1 well-made fishhook (pl. 24, fig. 1, *q*); and 12 bird bone beads of various lengths (pl. 24, fig. 1, *v*). One of the latter is neatly incised with encircling grooves. From level II come 5 pieces of thin, incised bone, 2 with perforations and incised angular designs (pl. 24, fig. 2, *p*, compare pl. 24, fig. 1, *r*); 2 flat and triangular awls of split bone, 1 very rough (pl. 24, fig. 2, *q*); 4 knapping tools, 1 a large rib ground to a rough point, the others rough bone fragments (pl. 24, fig. 2, *o*). In addition, there is a split deer cannon bone as well as some calcined and splintered fragments. Level I yielded 72 definite bone and antler artifacts: there are 15 knapping tools (of split bone, 1 small, 4 large bison ulnae, the others intermediate) (pl. 25, fig. 2, *k*); 14 rounded bone or antler awls (pl. 25, fig. 2, *b*); 22 split bone or antler awls, characteristically with an abrupt, shouldered point (pl. 25, fig. 2, *a*); 5 large gouges or scrapers of split bison bone, unworked except for the edge (pl. 25, fig. 2, *c*); 12 incised bone fragments with simple geometric designs (pl. 25, fig. 2, *f*); 4 bird bone beads (pl. 25, fig. 2, *g*); and a considerable number of split or worked fragments.

SHELL WORK

A small amount of molluscan material appeared in each level. These fragments have not been identified as yet, but fresh-water species appear to be the only forms represented. Level III yielded two fragments of shell and level II a handful of fresh-water mussel shell fragments. From level I comes one small, clawlike shell pendant with two notches at the top, several fragments of definitely cut or ground shells, and a number of broken, unworked pieces.

This concludes the listing and brief analysis of all artifact types recovered in our excavations at Signal Butte. The occurrence of two types of pottery in level III and its complete absence in levels II and I, with the marked differences in distribution and types of chipped points in all three levels (table 3), form the most striking demonstration of the cultural differentiation between the three levels which are physically separated by barren strata (fig. 29). The major cultural trends observable in this long human record and their apparent significance from the historic standpoint will be dealt with in later sections.

ANIMAL REMAINS

Dr. C. L. Gazin, of the United States National Museum, reports as follows on the very fragmentary animal material from Signal Butte:

In all cases where material is sufficiently good to permit specific identifications, living species are recognized. The fauna is that which is living in the region

at present or within historic times, and no evidence is seen by which one may assign any considerable age to the occurrence. Although probability favors a Recent time to the deposit, there is no certain evidence precluding a late Pleistocene age.

The *Bison* material is not sufficiently complete to permit specific recognition as species of this form cannot be identified without good skull and horn material. The size, shape, and position of horns play an important part in the diagnosis. From the material at hand, the form could be *Bison bison*.

The differences between the two mammalian faunas [I and II-III] is not important. Both are very incomplete, representing only a small percentage of the forms inhabiting the region at the two stages.

Gerrit S. Miller, Jr., adds:

I can see nothing in the *Bison* remains from either of the three levels to distinguish them from recent species. The teeth of the *Antilocapra* seem unusually large [level I]. I hope more of them will be found if further work is done at this locality.

The few bird remains, identified by Dr. A. Wetmore, are of existing species.

CONSIDERATIONS OF RELATIVE AGE

The main ramparts of Signal Butte were apparently isolated back in the Pleistocene, and for many thousands of years the mesa has probably been of about the same shape as at present, although scaling and erosion have been continuous. The earth cap is geologically recent and was formed primarily by wind action and secondarily by human occupations. The crescentic form of Signal Butte, backed by the main Wildcat escarpment (pl. 23, fig. 1), causes winds coming across the plains to be deflected either upward or around the two ends. This creates an eddy of comparative quiet over its top. Observation and experiment have shown that regardless of direction the winds tend to blow upward toward its center. This was unpleasantly apparent while screening operations were in progress. These eddying conditions over a long period have caused the deposition of the natural portion of the earth cap, the thin grass cover helping to hold this material in place. Presumably, this process would have commenced as soon as suitable material was available for the winds to carry. The formation of sand dunes in the valley of the Platte River, to which Signal Butte lies adjacent, point to the time, subsequent to the isolation of the butte, when dust became available. (The more detailed study on which this brief summary is based cannot be presented here but will appear in the complete report.) The dunes nearest to the butte are a patch, about 4 miles in area, 3 miles to the southwest. They are close to the abrupt escarpment of the Wildcat Range and have reached a point where prairie-sweeping winds are

affected by the sharp rise of the highland. This has stopped the migration of the dunes, for they are now sodded over and in places exhibit scant tree growth. The nearest sources for these dunes are not less than 10 miles distant from where they are now, and the more likely sources (according to the direction of the prevailing winds) are some $14\frac{1}{2}$ to 18 miles away. Estimating the time required for dune movement, at the highest speed the most reliable figures permit, it would have taken these dunes some 2,110 years to reach their present location. If they come from the north or the northwest, which is more logical, it would have taken them at least 3,100 years. More conservative estimates, based on slower rates of dune migration, would raise this period to about 5,200 years. Even then, the dunes would have to have been remarkably persistent in their movement. If more humid conditions intervened, as seems probable from the soil layers on the butte, the speed of the dunes would be materially reduced, and a temporary cessation of movement would be expectable. It is not likely that all the loess on Signal Butte and other high places in the vicinity came from such sand dunes, but it is believed that the origin of the dunes and of this loess came about at one and the same time. As the dunes began migrating and sifting their materials, the deposits on the highlands beyond, including Signal Butte, should likewise have been begun. Hence the estimated time of dune movement in this case should roughly correspond to the minimum age of the aeolian deposit on top of Signal Butte.

The two old soil horizons in the earth cap on Signal Butte are important factors in this discussion. These correspond with human occupation level I (a thick, black, soil line) and human occupation level II (a very thin and faint soil line). Level I lies directly on what we believe to be water-carried deposits of Pleistocene age and marks the beginning of the period of aeolian deposition. Above this comes a sterile layer of wind-borne material apparently representing a dry period. Following this, a thin soil horizon appears with evidences of human occupation (level II), which is covered by another sterile aeolian layer, again deposited under dry conditions. This is capped by a third period of occupation (level III) which immediately underlies the present sod line. This horizon is only slightly darker, especially at the top, than the sterile aeolian layer which underlies it. It is therefore obvious that the different strata on Signal Butte present evidence of climatic fluctuations during the Recent period.

Unfortunately, Sears could find no pollen in soil samples from any of these levels,⁸⁹ hence a botanical correlation with his suggested

⁸⁹ Letter from Paul B. Sears to Maurice E. Kirby, February 25, 1933.

chronology of postglacial changes in climate and vegetation in eastern North America (Sears, 1932, p. 621) is not possible. However, in a later letter⁹⁰ he states that if the material immediately below level I is old loess, then that horizon could be correlated with the cool, dry conditions previous to about 7,000 years ago. (Sears, 1932.) On the other hand, if the deposit (in and) below level I is definitely not aeolian, then (a) either the period before 7,000 years ago was not favorable to loess formation, which he doubts, or else (b) level I is very old, having been formed at or previous to 9,000 years ago, when conditions were cool and moist. (Compare Sears, table 3, 1932, p. 621.) In the latter case, level II is the only trace of the humid interval separating the cool dry from the warm dry periods, and is about 5,000 years old, with level I almost twice as old. From a photograph, he is inclined to believe that there is old loess below and in level I. Dr. W. Van Royen, who has visited the butte, but has not seen the best exposures of this sand and gravel layer (fig. 29) under level I, is likewise unconvinced of the fluvial origin of this deposit. (Personal conversation, January 1934.) On the other hand, Kirby's detailed study and mechanical analyses of this material have convinced us of the aeolian origin of level I (aside from human detritus) and of the water-borne nature of the silt and sand immediately beneath it. These sorted sand beds and silts occurred under level I throughout our excavations, especially in the west-central portion of the butte, and a test pit in the east end showed especially thick graded quartz sands in that area. The question can only be settled by full publication of the data and through checking by more competent authorities than Kirby and myself. This sand stratum, being barren of artifacts, has probably not been ruined by relic hunters. Moreover, there are at hand definite soil samples from all these levels. This is not directly an archeological problem but is presented here because of its probable bearing on dating the horizon and as an example of the manner in which prehistoric archeological chronology must always depend on the researches of geographer and geologist.

We may say then, subject to later correction, that level I on Signal Butte probably falls either in the dry, cool period (circa 8,000 years ago) or in the humid cold period (circa 10,000 years ago). In general, Kirby's time estimate of dune migration agrees. His estimate of 5,200 years as a probable minimum must be expanded if humid periods produced slackening rates, and there is evidence that humid periods occurred during the formation of the earth cap. This factor permits the general correlation of his minimum estimate with

⁹⁰ Paul B. Sears to Maurice E. Kirby, March 25, 1933.

the maximums given by Sears. The faunal material from the butte gives no positive clues save that a postglacial dating for level I is implied. However, recent research indicates that the Quaternary paleontologic record is at present a poor gauge for chronology when compared with the less spectacular but all important correlations with glacial phenomena and postglacial climatic fluctuations. For North America these last studies are in their infancy, but they promise objective results. Level II, from the same line of indirect evidence, probably falls into the humid period (Prairie Sub-humid of Iowa) (Sears, 1932, p. 621) of about 5,000 years ago, and level III into the humid period (Sub-humid, Maize optimum of Iowa) of the last 1,000 years. In this upper level (III), ceramics occur of a type that is entirely prehistoric. The bulk of this pottery (Upper Republican type) is identical with that of a prehistoric culture to the south and east which has an estimated age of 500 years. Thus the cultural remains in the three strata on top of Signal Butte appear to cover a period of some 7,000 to 10,000 years. At the present time this entirely tentative correlation with Sear's suggested chronology is a promising lead. Climatic fluctuations in postglacial time are suggested on Signal Butte as well as in Iowa peat bogs. There is no royal road to chronology, but the trail is being blazed by careful and conservative geologists, paleobotanists, geographers, and anthropologists.

OTHER SITES AND REGIONS IN NEBRASKA

If one were to enumerate all the other known archeological sites in Nebraska, they would make a surprisingly long list. A large number of these sites, as the foregoing account indicates, have been dug over by curiosity seekers; others fortunately have not been thus obscured or ruined and await careful scientific excavation. An enumeration or chart of such unworked sites would add little or nothing to our comprehension of prehistoric problems in Nebraska, and their publication at this time would inevitably lead to the loss of much valuable historic data. The writer is very strongly opposed to the publication of archeological maps which show the location of sites that have not been scientifically or completely excavated, for the reason that such maps are too often merely guides for relic hunters and thus defeat their own ends, which primarily envisage the advancement of knowledge. Nearly every small town throughout the United States has its quota of private collectors or relic hunters, and these become active in the use of such maps long before qualified archeologists, amateur or professional, can carefully excavate the sites thus

located. Furthermore, in little-worked regions, especially where distinctive potsherds are not numerous, such maps are utterly meaningless from the cultural standpoint. Thanks to the central agencies that now exist⁹¹ there is a growing spirit of cooperation between all those interested in preserving the past history of man in the New World, and such preliminary survey maps, on file at central institutions, are accessible to every qualified amateur and professional archeologist. For the above reasons the following discussion will be confined to those sites and regions which have either been thoroughly excavated or have an important bearing on the sites already discussed in detail.

During the summer of 1931 the Nebraska Archeological Survey excavated a prehistoric village near the modern town of Sweetwater, on a small intermittent tributary of the South Loup River in north-central Buffalo County (map, fig. 1, site 17). A complete report on this work will eventually be published but a brief consideration of the outstanding cultural factors revealed may be given here. Three earth lodges, all with a four-post central foundation, were excavated.⁹² One of the houses was perfectly round, one intermediate in shape, and one square in outline. In structure these houses resemble, or are intermediate in form to, both the round historic Pawnee earth lodges and the prehistoric square lodge discussed in connection with the Lost Creek site. There were numerous cache pits both inside and outside the houses, and several small refuse heaps were also excavated. The various houses, storage pits, and refuse heaps, as indicated by the material they contained, all represented the same culture. The ceramic remains are strikingly like those from Lost Creek and the Prairie Dog Creek ossuary, except that the Sweetwater rim sherds are characteristically decorated around the rim by impressed cords rather than by incisions (pl. 21, fig. 2, *c-m*). This feature alone sets the Sweetwater ceramics apart as a subtype of the widespread Upper Republican ware. In the preponderance of collars, horizontal and angular rim designs, and cord marking on the body of pots, a close resemblance to the Lost Creek or Upper Republican ware appears. A small proportion of the potsherds likewise show a characteristic

⁹¹ The Committee on State Archaeological Surveys (of the) National Research Council, Washington, D. C.; The Bureau of American Ethnology, Smithsonian Institution, Washington, D. C.; and, for Nebraska particularly, the University of Nebraska Archeological Survey, University of Nebraska, Lincoln, and the Nebraska State Historical Society, Lincoln.

⁹² Photographs of these houses, excavated and photographed by W. R. Wedel, have been published. See Strong, 1932, fig. 146.

red hematite stain on their inner surface (pl. 21, fig. 2, *k*). Pottery was abundant at this site. Chipped flint artifacts include triangular unnotched arrowpoints (NBa) most numerous, double notched points (NBa1) next, and only one slender, stemmed point (SCb2); oval knives (often beveled), small end scrapers, and chipped celts. Bone artifacts include scapula hoes, bone awls, fragments of bone bracelets (dot and line decoration), bone beads, bone fishhooks, and cylindrical antler tapping tools. One broken polished stone celt, perforated disk shell beads, one perforated shell gorget, perforated and fired clay disks, and two modeled clay elbow pipes are also reported from the site, a cultural content that is closely similar to that from the Lost Creek site earlier described. No burials or ossuaries were located, though a few human bones were found in one of the cache pits.

The Sweetwater site is only one of a large number of such prehistoric villages, often associated with ossuaries, in both the Loup and Upper Republican River valleys. A great number of these sites have been located and partially investigated by A. T. Hill. Judging from Mr. Hill's description, all of these sites present much the same type of culture as the prehistoric Lost Creek (Republican) and Sweetwater (Loup) sites already discussed. He calls attention to minor differences, such as the matter of using cord impressions rather than incision for rim decoration, between the Loup Valley prehistoric pottery and that of the Upper Republican, and further notes that polished celts and the draw-shave type of bone beaming tool occur in the eastern sites.⁹³ My personal impression is that the majority of these small village and ossuary sites represent the same general culture, the differences being due to local variations and perhaps to their representing slightly different time periods.

A large village site near Max, in Dundy County (map, fig. 1, site 29) on the western extension of the Republican River, has been reported on by Loren Eiseley.⁹⁴ Many house pits were noted here, but none was excavated. However, the abundance of flint artifacts in a nearby plowed field permitted a sampling of the culture represented. Pottery was rather scarce, and no rim sherds were found; hence it cannot be stated whether the Lost Creek (i. e., Upper Republican) type of pottery occurs here. However, Mr. Eiseley found one indubitable "black on red" Pueblo potsherd, which to the best of my knowledge is the first typical southwestern pottery fragment reported from Nebraska. The significance of its occurrence on the surface of an ap-

⁹³ Correspondence with A. T. Hill, winter of 1931-32. These problems are discussed, and much new data presented, by Wedel, 1935, I and IV.

⁹⁴ Correspondence with Mr. Eiseley, winter of 1931-32.

parently prehistoric Nebraska village is unknown. Flint work was abundant here, numerous end scrapers, side scrapers, knives (both well worked and extremely crude), and T-shaped drills being reported.

One of the largest streams flowing from the north and west into the Republican River is Medicine Creek, which extends from northwest Furnas County through Frontier County into Lincoln County, almost reaching to the North Platte (map, fig. 1, site 18). This stream valley was followed by a much-used war trail during the Indian wars and abounds in evidence of prehistoric occupation as well. During the summer of 1931 the writer, guided by A. T. Hill, visited many of these sites, following up the valley from south to north. The valley of Medicine Creek has since been systematically investigated by Hill and Wedel (Wedel, 1934, and 1935, I) and its outstanding culture, a variant of the Upper Republican, described in detail. Characteristic Medicine Creek rim sherds (pl. 21, fig. 2, *a-d*) are figured in the present paper. In the light of the fuller data obtained by Hill and Wedel, the earlier surveys by myself and by others are superseded. Mr. Eiseley, however, has found fragments of worked steatite in sites near Cambridge, Nebr. This calls to mind a cylindrical, steatite bowl (27.5 cm in diameter) plowed up by C. W. Malroy near Cambridge in 1902. The specimen is now in the Hill collection at the Hastings (Nebr.) Museum. Harlan I. Smith (1910, p. 518) reports soapstone vessels from southern Wyoming, but artifacts of this material are rare or unknown in other sites reported from Nebraska.

Following up the Medicine to the North Platte River, we come to another interesting region where rock shelters, blow-outs, and open sites occur. Several rock shelters here have been excavated by Dr. E. H. Bell, and reports on this work will be forthcoming. Another variant of the Upper Republican culture, similar to that from the upper level on Signal Butte, occurs in this region, hence it has been included in the map (fig. 1, site 19). Since a further report on this area based on excavation is in preparation by Bell there is no need of giving the results of my preliminary surveys. Renaud (1934 a) has already published the results of his archeological survey of western Nebraska.

In November 1932 an aboriginal site near the town of Butte, in Boyd County (map, fig. 1, site 31) was called to public attention by workmen digging a sand pit. Located on Ponca Creek, in the little-worked northeastern corner of Nebraska, the cultural remains so far unearthed at the site and preserved in local collections seem to be exceptionally interesting. On hearing of the find Dr. E. H. Bell, Director of the University of Nebraska Archeological Survey, sent

Waldo R. Wedel and Lee Daniels to examine the site. According to Mr. Wedel⁹⁶ the Butte material came from a number of cache pits situated on a high flat terrace about 200 feet above Ponca Creek. Artifacts occur over an area of some 10 to 15 acres, with numerous cache pits strung along the edge of the terrace. The village site is marked by low gravel-covered mounds, but whether these are lodge sites, refuse heaps, or neither is not yet clear. According to Wedel, the pottery, which is abundant, is similar in many respects to the Upper Republican (Lost Creek, etc.) ware, having collared rims; parallel incised-line rim decoration; zones where the lower edge of the collar has been pinched up between thumb and forefinger and, I presume, cord marking on the body of the vessel. On the other hand, much of the ware has high, direct undecorated rims, wide lugs or tabs, a yellowish color, and lacks cord marking, all of which features are distinct from those of the Upper Republican pottery type and suggestive of Nebraska Culture ceramics. Wedel and Daniels picked up numerous surface sherds of both types and note that the local collectors place both types in the same containers, claiming that they come from the same pits. On the basis of limited excavation Wedel is inclined to think that this is actually the case. It is possible that stratification of two cultures each marked by a distinctive pottery type occurs here, although from Wedel's observations it seems more probable that there has been a partial cultural amalgamation. This will be discussed in the concluding sections of the present paper, the point here stressed being the fact that the Upper Republican type of pottery, albeit mixed or amalgamated with pottery of another type, occurs in the northeastern part of the State.

In this regard a point already noted must be stressed, namely, the occurrence of apparently numerous prehistoric village and burial sites on the Upper Elkhorn River near the town of O'Neill, Holt County (map, fig. 1, site 30). Unfortunately, no members of the Survey have had the opportunity of examining these remains, which have been called to public attention by J. B. O'Sullivan, of O'Neill.⁹⁸ From the available descriptions numerous house pits mark these sites, some of which yield only bone artifacts while others have considerable pot-

⁹⁶ Letters of November 21 and December 7, 1931. Sites in this vicinity have since been investigated by Dr. E. H. Bell, and detailed reports are being prepared. The culture represented here seems to be a hybrid between what we have called the Nebraska and the Upper Republican cultures.

⁹⁸ Omaha World-Herald, Sunday, December 22, 1929. Mr. O'Sullivan has also furnished the writer additional information, letters of January 7 and August 5, 1930.

tery and stone artifacts. The pottery is said to be grit- or gravel-tempered, cord-marked, decorated with incisions and occasionally with a red ocher slip. According to the newspaper article cited, decoration also consists of pinching, modeling in relief, stamping, and basket impressions. Mr. O'Sullivan believes it to be of Caddoan (i. e., Pawnee) origin. Stone pipes, abundant small arrowheads, some sort of soft red stone suggesting brick, obsidian, and numerous other artifacts are reported. Although it is impossible to form any definite impression as to the culture represented, the incised, cord-marked, and sometimes ocher-stained pottery, the stone pipes, and tiny arrow-points suggest our Upper Republican type. Whether the upper Elkhorn River villages represent a pure Upper Republican culture, a blend with the Nebraska culture such as seems to occur at Butte, or a totally new type must be settled by future research. As will be pointed out later, this region, directly between the upper Missouri River area and the numerous prehistoric sites on the Loup and Republican Rivers, seems of strategic importance in tracing the movements of prehistoric populations west of the Missouri in Nebraska.

In extreme southeastern Nebraska Sterns (1915 a) briefly describes a large protohistoric or late prehistoric camp site on the Nemaha River near Rulo (map, fig. 1, site 32). Abundant pottery is reported from here, which is characteristically lump-modeled, smooth surface, yellow to brown-black in color, thick, and shell-tempered. Round-bottomed pots seem to have been the prevalent form. Horizontally perforated lugs are common, the rims of vessels are scalloped, and crude gouges and linear incisions decorate both the body of the vessel and in some cases the inner portion of the rim. Besides pottery, sandstone shaft polishers, small end scrapers, long chipped knife blades, and arrowpoints similar to those of the Nebraska culture occur. Similar remains on Wolf Creek in Kansas are also noted, and since this pottery type is not found beyond the range of the Kansa, who had villages in the region about 1725, Sterns (1915 a, II, pp. 171-177) suggests that these sites pertain to this tribe. (Compare Harrington, 1924, pp. 18-19.) The relationship of this seemingly distinct ceramic type to those known elsewhere in Nebraska remains to be determined. It may account for certain of the shell-tempered sherds found in Nebraska culture sites and should be carefully compared with Oneonta culture pottery from Iowa. The entire region of southeastern Nebraska is a promising and little-known field.

This concludes our hasty survey of sites as yet incompletely investigated which seem to have a definite bearing on problems raised by the more complete excavations previously discussed. It remains

to sum up the characteristics of the various sites so far excavated and to determine, in so far as is possible at this early stage, into what larger wholes or cultures (aspects) they may be grouped.

GROUPING OF SITES AND SUMMARY OF CULTURES REPRESENTED

Up to the present only one major prehistoric culture has been at all clearly defined in Nebraska, namely, the "rectangular earth-lodge culture" of Sterns or the "Nebraska culture" of Gilder, the latter designation being the one employed in the present paper. To this must be added the dwelling type and artifact complex revealed in the lower strata at the Walker Gilmore site, which, since its discoverer used no general name in describing it, I have termed the Sterns Creek culture. The foregoing descriptive sections have indicated that other prehistoric culture types in Nebraska are also represented in the recent discoveries. In the present section all the prehistoric sites previously described will be grouped according to their apparent cultural affiliations, and the major units thus distinguished will be discussed. The "Suggested Cultural Classification" chart in the foreword of the present paper should be consulted in this regard. Naturally, a number of such prehistoric sites are not yet classifiable into any larger comprehensive groupings or cultures. Since the historic and protohistoric Pawnee cultures have already been treated in a summary fashion, they are also included in table 4, which draws together all of the Nebraska archeological sites dealt with in the present paper. The general location of these sites is indicated on the map (fig. 1), and the cultural affiliation of every site that can be so classified is indicated in table 4 (p. 246).

THE UPPER REPUBLICAN CULTURE

Since the known characteristics of historic and protohistoric Pawnee culture have already been summarized, they need not be discussed here. However, along the Upper Republican River and on the lower reaches of the different branches of the Loup River are a number of prehistoric sites which show many marked Pawnee characteristics. Since the first of these sites were excavated on the upper Republican River, this cultural grouping has been tentatively designated as the Upper Republican culture, although the writer feels that the designation Prehistoric Pawnee can eventually be applied to these sites. However, until the transitions between the Upper Republican culture and that of the protohistoric and historic Pawnee have been entirely

worked out, it seems safer to use a geographic rather than a tribal designation. To judge from the imperfectly known distribution of the ceramic type found in Upper Republican culture sites, the culture occurs in southwestern Nebraska as far west as Red Willow Creek and on the North Platte River as far west as Signal Butte. It apparently centers along the Republican and Lower Loup Valleys and

TABLE 4.—*Grouping of Nebraska Archeological Sites According to Cultures (Aspects)*⁹⁷
Classified sites (see Map 1, fig. 1)

Historic Pawnee	Protohistoric Pawnee	Upper Republican	Nebraska	Dismal River (?)
1. Palmer	11. Burkett	13. Lost Creek	20. Rock Bluffs	23. Site 1, Dismal River
2. Cottonwood Creek	12. Schuyler	14. Prairie Dog Creek	21. Gates	24. Site 2, Dismal River
3. Horse Creek		15. Alma	22. Saunders	25. Site 3, Dismal River
4. Fullerton		16. Munson Creek		
5. Genoa		17. Sweetwater		
6. Clarks		18. Medicine Creek sites		
7. Linwood		19. North Platte sites		
8. McClaine				
9. Leshara				
10. Hill				
Stratified Sites				
26. Walker Gilmore	{ II Nebraska culture I Sterns Creek culture	27. Signal Butte	{ III Upper Republican and Dismal River II Signal Butte II I Signal Butte I	
Unclassified sites (or uncertain classification)				
28. Marshall	31. Butte	34. Bird Creek	37. Spring Creek (fossil bison)	
29. Max	32. Rulo	35. Cumro (fossil bison)	38. Angus (?) (mammoth)	
30. O'Neill	33. Weeping Water	36. Grand Island (fossil bison)		

crops up under rather strange circumstances in extreme northeastern Nebraska on the Missouri River. So far as known, sites of this culture do not occur along the Missouri River in central or southern Nebraska, in which region Nebraska culture sites are numerous. The Upper Republican culture probably occurs on the upper Elkhorn River, but this is uncertain at present. Its suggestive but as yet very poorly recorded occurrence beyond the boundaries of Nebraska both to the north and to the south will be referred to later.

⁹⁷ These sites are located on map (fig. 1).

Our present knowledge of this culture (1932) depends on excavations in two villages (fig. 1, sites 13, 17), three ossuaries (fig. 1, sites 14, 15, 16), and other sites (fig. 1, sites 18, 19), besides reports on similar villages and ossuaries furnished by A. T. Hill, which are not specifically listed here. Since ceramic remains seem particularly significant in indicating the relationship between the various sites grouped under the term Upper Republican culture, this characteristic phase will be briefly outlined. This has already been done in some detail in earlier sections dealing with the Lost Creek, Prairie Dog Creek, Alma ossuary, Munson Creek ossuary, Sweetwater, Medicine Creek, North Platte, Signal Butte, and Butte sites, hence only a brief recapitulation of the salient characteristics is necessary at this time. Briefly, then, Upper Republican pottery is a well-made, rather hard ware with grit tempering. This tempering material is usually a rather fine pulverized stone, though occasionally coarse sand and gravel is employed. In color, a gray tone predominates, ranging to a light buff in some cases. The surface of the ware is smoothed off but never highly polished. It does not appear to have been treated with oil, and with one exception a slip of any sort is absent. This exception is the occurrence of a bright red hematite stain, often applied prior to firing, on the inner surface of a small proportion of sherds at nearly all such sites. Decorative effects are also secured by cord markings over the outer surface, apparently applied with cord-wrapped paddles. The percentage of cord-marked ware as compared with plain ware appears to be rather high (90 percent at Lost Creek, house 1, and 94 percent at the Prairie Dog Creek ossuary). A similar predominance of cord-marked ware seems to occur at other sites of this culture that have been investigated, but exact figures are not available. There is no doubt as to the nature of these paddle marks, since the impress of cords, often vertically applied, is clearly visible on many sherds.

Rims of this ware are characterized by a predominance of definite collars, geometric incised designs confined to the collars, and incisions across or along the top of the lip of many vessels. At the Lost Creek site, house 1, 82 percent of rims had definite collars and at the Prairie Dog Creek ossuary slightly less than 50 percent. The rim forms and incised decoration at two Lost Creek type sites in the Upper Republican Valley are indicated in table 5 (p. 248).

Incised decoration is confined to the collars or necks of vessels and to the tops of rims, which are often notched. Handles or lugs are almost lacking in such sites on the upper Republican River and rare in those that have been investigated on the Loup River. Another

characteristic mode of decoration on collared rims consists of a zone at the lower edge of the collar which has been pinched up between thumb and forefinger, leaving a series of depressions with sharp ridges or nipples between them. (Pl. 9, fig. 1, *d*, illustrates the type.) All of the characteristic rim decorations and other features of this ware can be seen in plates 5, 9, and 21.

Although identical in all major characteristics, the ceramics pertaining to this culture from the Loup drainage exhibit certain ad-

TABLE 5.—*Types of Rims from Two Upper Republican Culture Sites*

	House 1, Lost Creek	Prairie Dog Creek Ossuary	Total
Rim sherds with marked collar:			
Collar decorated with incised horizontal lines (pl. 5, fig. 1, <i>b, e</i> ; fig. 2, <i>d</i>)	29	5	34
Collar decorated with incised design of chevron type (pl. 5, fig. 1, <i>g, k</i>)	7	1	8
Collar decorated with incised design of diamond type (pl. 5, fig. 1, <i>a, d</i> ; pl. 9, fig. 1, <i>b, e</i>)	2	6	8
Collar decorated with incised design of barred triangle (pl. 5, fig. 1, <i>l</i>)	1	...	1
Collar without incised decoration but with notches along lower edge (pl. 5, fig. 2, <i>c</i> ; pl. 9, fig. 1, <i>a, d, f</i>)	2	15	17
Collar without incised decoration or notches along lower edge (pl. 5, fig. 1, <i>i</i> ; pl. 9, fig. 1, <i>c</i>)	8	28	36
Rim sherds without collar:			
Neck decorated with incised horizontal lines (pl. 5, fig. 1, <i>h</i>)	3	...	3
Neck decorated with incised design of chevron type (pl. 9, fig. 1, <i>n</i>)	1	1
Neck decorated with incised design of diamond type	2	...	2
Neck without incised decoration (pl. 9, fig. 1, <i>h, i, j, k, l</i>)	4	57	61
Rim sherds with lugs or handles	1 (?)	...	1
Total			172

ditional features. The site at Sweetwater, since it is the only one of this culture extensively investigated, may be taken as typical, especially since superficial examination reveals the Sweetwater type of pottery at numerous other sites in the region. So far as pottery is concerned, therefore, the ceramic complex of the Upper Republican culture can at present (1932) be divided into two phases (focii), a Lost Creek phase (Republican River) and a Sweetwater phase (Loup River). The Sweetwater phase apparently has all the characteristics of the former with the addition of single cord impressions forming geometric patterns on the collar of vessels, plus the occasional use of loop handles and lugs (pl. 21, fig. 2, *e-m*). When the pottery

collections from the Sweetwater site have been intensively studied, the degree of these and possibly other specializations may appear. However, in general appearance and essential characteristics the two ceramic phases are very similar.

Not only do the sites included in the Upper Republican culture have a common distinctive ceramic type, but they also possess a particular artifact complex. In brief outline this consists of rather abundant elbow pipes cut from soft stone; rare pottery pipes; sandstone shaft polishers with the elongate oval or "buffer" shape prevailing; small discoidal and ungrooved hammerstones; two main types of arrowpoints, a large (NBa) triangular point of rather rough workmanship and a small (NBa, 1-4) type, very delicately chipped and often notched (table 3); small planoconvex end scrapers; small ovoid side scrapers; oval, triangular, and diamond-shaped knives, the latter type beveled and unbeveled in about equal proportions; chipped celts; very rarely, polished celts; excellent bone and antler work, including incised bone and antler bracelets, awls, picks, scapula digging tools, small bone fishhooks, bone beads, cylindrical antler tapping tools or punches, perforated antler shaft straighteners and occasionally bison rib shaft straighteners; shell artifacts, including cylindrical shell beads; small, perforated, clawlike pendants, cut shell ornaments (including molluscan species from the Gulf coast); and (at one ossuary site) wooden disks covered with beaten copper. A majority of the above artifact types were found in each site assigned to the Upper Republican culture that has been intensively excavated. Their proportion of occurrence also appears to be very uniform at all such sites.

Although limited in amount, the evidence regarding the dwellings of the Upper Republican culture is suggestive. So far only one house at Lost Creek and three houses excavated by Wedel at Sweetwater are known in detail (1932). The first of these was practically square with an eastern and a western entrance passageway and a four-post central foundation. One of the houses at Sweetwater was perfectly round, another was squared on three sides and rounded on the other, and the third was perfectly square. All had central fireplaces, long post-lined entrance passageways, and a four-post central foundation. The available evidence therefore suggests that a subsurface earth lodge was typical, and that these were predominantly square or rectangular in outline, though the circular lodge was also in use. The latter type is practically identical with the protohistoric Pawnee earth lodge.⁹⁸ Storage pits are located both inside and outside the houses

⁹⁸ This correspondence can be seen by comparing the diagram of a protohistoric Pawnee house, fig. 3, with the photograph of the round Sweetwater house previously published, Strong, 1932, fig. 146, c.

and are usually somewhat bell-shaped, with flat or slightly rounded bottoms. The occurrence of stone slabs forming floor areas in both lodges and caches may be a cultural characteristic as well.

The interments of the Upper Republican culture, so far as known, are in hilltop ossuaries in which previously exposed and rather fragmentary human bones have been deposited with a variety of broken and unbroken artifacts. Disk shell beads are fairly common in the sites of this type so far excavated. Local report indicates that stone-slab graves were employed by the bearers of this culture along the valley of Medicine Creek, but this awaits scientific confirmation. In all cases where ossuaries have been grouped with other Upper Republican culture sites, this has been done because potsherds of Upper Republican ware were abundant in such ossuaries. On the basis of the present evidence, however, the segregation of the Upper Republican culture as a historical unit seems justified. The relation of the Upper Republican to other historic and prehistoric cultures will be discussed in the next section of this paper.

THE NEBRASKA CULTURE

Compared to the newly distinguished Upper Republican culture a great deal is on record concerning the Nebraska culture. This latter culture was first recognized and named by Gilder, but to date has been most exhaustively studied by Sterns, whose unpublished manuscript is the most complete treatise on the Nebraska culture extant.⁹⁹ Sterns excavated in 27 houses of the Nebraska culture type, his results being summed up in the unpublished paper referred to and his collections being preserved in the Peabody Museum at Cambridge, Mass. Since in its present form this paper is not available to many students, I have, with the author's permission, included certain of Sterns' summaries in the present report. Gilder has dug in a very large number of sites of this type, but only a small proportion of these results have been written up or printed, and much of his archeological material is scattered. The work of the University of Nebraska Archeological Survey during 1929-1931 included excavation in two villages (fig. 1, sites, 20, 21) and two habitation sites, one of which was associated with an ossuary (fig. 1, sites 22, 26), all pertaining to this culture. In the following an attempt is made to draw together the main results of Gilder, Sterns, and the writer to form a reasonably complete picture of the Nebraska culture as a whole.

⁹⁹ Sterns, 1915 a. References in the present section to Sterns' work for which no citations are given refer to this manuscript, vol. 2.

Owing to the more abundant and occasionally contradictory nature of the data, this cannot be done as concisely as it was for the less fully investigated Upper Republican culture.

The Nebraska culture has so far been revealed in a large number of sites in eastern Nebraska and northeastern Kansas bordering the Missouri River. Although its boundaries have been incompletely investigated, it is known to extend from Thurston County, Nebr., south to Doniphan County, Kans. Apparently, it also occurs on the eastern side of the Missouri River as the recently distinguished Glenwood culture, which awaits full description by Dr. Keyes. The cultural complex revealed in these eastern Nebraska sites was designated by Sterns as the "rectangular earth-lodge culture," but since rectangular dwellings characterize the Upper Republican culture as well, Gilder's term "Nebraska culture" seems preferable.

The Nebraska culture is particularly characterized by abundant and distinctive pottery remains. Examples of this pottery obtained by the Survey, as well as certain pieces collected at an earlier date by Gilder and now in the Nebraska State Museum, are illustrated in plates 13, 14, 15. The paste of the Nebraska culture ware is usually smooth and well mixed and in the majority of specimens has a flaking rather than a crumbling texture. Grit tempering predominates, usually a medium fine sand or pulverized rock, though gravel is occasionally used. Sherds with the latter type of tempering represent the poorest quality within the ware. Sparkling iron pyrites, a little-ground-up limestone, hematite, and, in a few rather aberrant sherds, shell are all occasionally used for tempering. When fine tempering material has been used, the ware is rather hard, but when gravel has been employed, it is softer and more crumbling in texture. The prevailing color is a reddish brown ranging from orange or brick-red to an almost gray or black tone. Since the majority of this pottery has been used for cooking, much of it is fire-stained or smoke-blackened. As Sterns points out, this variation in color seems mainly to be the result of somewhat different degrees of firing combined with slightly different clays locally employed.

The surface of this ware is usually polished but rarely has a lustrous appearance. In a few cases the complete vessel seems to have been boiled in (maize?) oil, giving it a more shiny appearance (pl. 14, fig. 1, *c*, fig. 2, *h*). The nearest approach to a slip is a gray-white wash on a few potsherds obtained by the Survey, which had evidently been applied on inner and outer surfaces prior to firing. Sterns notes that a few small vessels he collected contained red hematite paint on the inside, as though used for paint pots. The surface is paddle-

marked in a number of cases, but this may be mentioned under the heading of decoration.

Decoration is mainly effected by the modeling of rims and secondary features. A few typical Nebraska culture pots have simple incised designs on the body, but there are also a number of unique shell-tempered and well-incised sherds in many of these sites which appear to be intrusive. Modeling rather than incision typifies the ware. According to the Survey findings paddle marks appear on less than 50 percent of the Nebraska culture sherds (at Rock Bluffs site, house 2, 38 percent; at Gates site, house 1, 18 percent; house 2, 20 percent, and house 3, less than 50 percent). Thus, as far as the Survey finds are concerned, polished and plain ware predominates. Of the paddle-marked ware, some sherds show certain definite traces of cord imprints. The bulk of the paddle-marked ware, however, is too much obscured by subsequent smoothing for one to be certain as to the exact nature of the original paddle marks. Sterns makes a general statement that nearly all his sherds show evidence of grass-wound paddle markings, often almost obliterated by subsequent polishing. Since he gives no statistics in this regard it remains for future analysis to determine whether a predominance of paddle-marked ware as mentioned by Sterns, or a predominance of plain ware as occurs in the Survey findings, is typical of Nebraska culture pottery. The same must be said regarding the different classification of these marks in the present paper as cord imprints or as imprints of grass-wrapped paddles according to Sterns. The decorative effects obtained by modeling of rims, lugs, and handles may be discussed under the general heading of form.

Pots are the most common form of vessels in this culture, though open-mouthed bowls, a few bottle-necked vessels, and numbers of irregularly shaped small vessels, possibly toys, are also found. Certain effigies and pottery tobacco pipes will be discussed separately. To judge from the lack of any evidence of coiling combined with the irregular, often indented interior surfaces of pots, the Nebraska culture pottery appears to have been hump modeled, probably with paddle and anvil stone. Globular vessels with round bottoms predominate, and the majority seem to have had either lugs or handles. Rim types are variable, as table 6 indicates.

From this table it can be seen that collars are rare in this type of ware, whereas straight or slightly flaring, unmarked rims are most abundant. Where decoration occurs on rims, it takes the form of "piecrust scallops," i. e., pressed between thumb and forefinger, or else a series of diagonal incisions around the outer lip made with

a rather blunt instrument. So far as the Survey collections from Sarpy and Cass Counties are concerned, rim sherds with plain lips greatly outnumber those with incised or finger-marked lips. Lugs

TABLE 6.—Types of Rims from Nebraska Culture Sites Excavated by the Survey

	Rock Bluffs site		Gates site			Total
	House 2	House 5	House 1	House 2	House 3	
Rim sherds with collar:						
a. Rim with slight collar decorated with cord marks and (or) incisions (pl. 15, fig. 1, <i>h</i> , fig. 2, <i>a, b, c</i>)	2	0	5	3	1	11
Rim sherds without collar:						
b. Rim straight or with slight flare, plain lip (pl. 14, fig. 1, <i>e</i> ; pl. 15, fig. 1, <i>d, e, f</i>)	27	7	16	69	7	126
c. Rim straight or with slight flare, incised or finger-marked lip (pls. 13, <i>b</i> ; 15, fig. 1, <i>a, b, c</i>)	20	1	9	5	0	35
d. Rim with small punctate decoration outside and below lip	2	0	0	0	0	2
e. Rim with incised pattern on neck	0	0	0	0	0	0
Rim sherds (without collar) with lugs:						
f. Rim having round lug with vertical perforation (pls. 13, <i>b</i> ; 15, fig. 2 <i>g</i>)	8	5	2	4	1	20
g. Rim with flare forming lug with vertical perforation (pls. 14, fig. 1, <i>d</i> ; 15, fig. 2, <i>f</i>)	1	0	2	1	0	4
h. Rim having lug with horizontal perforation (pl. 15, fig. 2 <i>i</i>)	0	0	0	1	0	1
i. Rim having horizontal unperforated lug (pl. 15, fig. 2, <i>e, h</i>)	2	1	2	2	0	7
j. Rim having vertical unperforated lug	1	0	0	0	0	1
Rim sherds (without collar) with handles:						
k. Rim with plain loop handle (pl. 14, fig. 1, <i>e</i> ; fig. 2, <i>h, j, k, l</i> ; pl. 15, fig. 1, <i>i</i>)	4	1	3	13	2	23
l. Rim with indented loop handle	1	0	0	0	0	1
						231

are common on these sherds, vertical perforations predominating over the unperforated and the rare horizontal perforated lugs. Lugs may be formed merely by a flare at each end of the rim which is perforated; by having the upper edge of the lug formed by an extension of the rim with a keylike projection on the lower end which pene-

trates the wall of the pot ; or in more unusual cases by having two such keylike projections on each end of the lug. Unperforated lugs are usually thickened extensions on the wall of the vessel. From the proportion of lugs in his collection of rim sherds Sterns estimated that they occurred in 40 percent of the vessels in this culture. Handles are also common, the single-loop handle placed vertically being the main type. In a few cases these lugs are modeled to represent horned creatures, birds or animals (pls. 15, fig. 2, *d*, 16, fig. 1, *c*).

In size, Nebraska culture vessels range from large pots holding as much as 6 gallons to tiny toy vessels the size of a quarter dollar. Smaller pots holding a gallon or less and from 5 to 7 inches in height are most common. The smallest vessel secured by Sterns had a diameter of 2 inches across the mouth and held $1\frac{1}{2}$ ounces, while the largest was 10 inches in mouth diameter and held 6 gallons. The average capacity of his complete vessels was between 1 and 2 gallons. Crudely modeled and tiny pots and ladles suggest either the work of children or else by-products of the adults' work which were used as toys.

Sterns attempted a regional classification of his Nebraska culture ware from Washington, Douglas, Sarpy, and Cass Counties, dividing it into four subtypes: Northern (northern Douglas and Washington Counties), Central A (Sarpy County along the Missouri River), Central B (Sarpy County away from the river), and Southern (sites around Murray, Cass County). In form, color, and predominance of grit tempering no regional differences were noted, although some limestone, hematite, and shell was also used as tempering in Central B ceramics. In size, the vessels from his Northern sites were larger than those from Southern sites. Lugs with vertical perforations were common in Southern sites, intermediate in number in the two Central regions, and rare in Northern sites. The Central sites (both divisions) had the largest number of unperforated lugs. In regard to horizontally perforated lugs, these were most abundant in Northern sites, next in abundance in the Central sites, and the Southern sites had less than half as many as the Northern. The size of lug perforation was greatest in the Northern and Central sites and smallest in those of the Southern group. Since this decrease in size of perforation is proportionately greater than the decrease in size of vessels from north to south, Sterns regards it as significant, perhaps indicating the use in the south of a small, stout cord for suspension. This would also correspond to the greater prevalence of vertical perforations in lugs from Southern sites. In regard to rim, decorative incisions or finger markings are lacking in the majority of rims from

Southern sites, whereas in Northern sites the majority are thus decorated. The Central B group agrees in this regard with the Northern group, whereas Central A is intermediate between Northern and Southern. Finger markings predominate in such decoration at Northern sites, incisions at Southern sites.

Unfortunately, the material obtained by the Survey was studied prior to the examination of Sterns' manuscript; hence entirely comparable statistics are lacking. Nevertheless, since the Gates site is in Sterns' Central B area and the Rock Bluffs site in or close to his Southern area, it is possible to compare them. The rim types obtained by the Survey coincide with Sterns' classification rather well; the Southern (Rock Bluffs) site has a predominance of vertically perforated lugs in spite of a smaller representation of pottery than has the Central B (Gates) site. In the marked scarcity of horizontally perforated lugs and the relative scarcity of unperforated lugs at both sites they fall in with Sterns' Central and Southern types. Since finger-marked and incised rims are in a minority at both the above sites, they also agree with Sterns' Central and Southern types in this regard. Thus, so far as the limited Survey collections are concerned, Sterns' typological distinctions seem justified.

The considerable range and large number of known Nebraska culture sites, combined with the regional variations pointed out by Sterns, give definite promise of either tracing out the development of the culture *in situ* or of tracing the direction from which it reached eastern Nebraska. Although hundreds of these sites, especially in the neighborhood of Omaha, have been unsystematically looted, it is possible that careful excavation of the remainder with subsequent detailed analysis of their entire ceramic content will go far in elucidating this problem so well begun by Sterns.

An interesting and significant point which must be mentioned before leaving the subject of Nebraska culture pottery is the matter of intrusive vessels and sherds found in such sites. Both Gilder and Sterns report the discovery in numerous sites pertaining to the Nebraska culture of limited amounts of dark, often shell-tempered and beautifully incised sherds, a ware contrasting markedly with the usual run of ceramics at these sites.¹⁰⁰ In the Nebraska culture sites excavated

¹⁰⁰ Sterns, 1915 a, and Gilder, 1926, p. 32. The latter authority in his papers of 1907, 1909, 1913, and 1926 illustrates a large number of rim sherds, mostly from the Omaha region and of the Nebraska culture type. Many of these intrusive types are also shown. However, since these plates figure so many types of rims rare or lacking in the collections obtained by Sterns or by the Survey, with no data on their exact provenience, I have not felt safe in using this material for comparative purposes.

by the Survey, 13 sherds from house 2, Rock Bluffs, 4 sherds from house 1, 1 small pot and 35 sherds from house 2, and 3 sherds from house 3, at the Gates site, were of this thin, dark, and neatly incised ware. Although certain of these sherds suggested a fine shell tempering, two black, lustrous sherds with a gray-buff interior surface and abundant shell tempering also came from house 2, Gates site. In addition to this shell-tempered and often incised ware Sterns also found a fragmentary incised vessel or dipper with a solid cylindrical handle. Both this latter type of vessel and the lustrous black shell-tempered ware are found at the important Cahokia site in Illinois¹⁰¹ and represent northern extensions of common Middle Mississippi ceramic types.

Two explanations are possible for the occurrence of such ware in small amounts in Nebraska culture sites: either there were direct trade relations between the people of the Nebraska culture and peoples to the south and east or else there were outposts of the latter culture (or cultures) in eastern Nebraska. That the latter may have been the case is suggested by the fact that Sterns partially excavated earth lodges near Peru, Nebr., in which a dark, neatly incised and often shell-tempered pottery was the predominant type, and he suggests that these were the people who traded with the Nebraska culture people, thus introducing small amounts of such ware into an otherwise homogeneous ceramic complex. Such an explanation would account not only for the occasional appearance of such alien sherds or vessels in Nebraska culture sites, but also, if the cultures were contemporaneous, for the occurrence of a few poorly executed designs of this incised type on otherwise typical Nebraska culture vessels (pls. 14, figs. 1, *c*, 2, *h*; 15, 1, *d*, 2, *f*). The writer has also been told by Dr. Gilder of certain sites in the vicinity of Omaha excavated by the latter which contained only incised ware. It thus seems highly probable that in southeastern Nebraska there were one or more peoples contemporaneous with the Nebraska culture but apparently somewhat more advanced in ceramic technique. Both Gilder and Sterns apparently excavated in sites of this latter type, but none of these has been completely worked or reported on.

The discussion of Nebraska culture pottery may be concluded with a brief consideration of the most striking differences that set it apart from Upper Republican culture ceramics. These may be summed up by the statement that, although the Upper Republican culture ceramics are characteristically gray in color, have a high percentage of clear, evenly applied cord markings on exterior surfaces, are predominantly

¹⁰¹ Shetrone, 1930, see pot illustrated in fig. 219; Moorehead, 1928, pl. 17, no. 3.

without handles or lugs, have a great predominance of collared rims decorated with geometric incisions or heavy cord marks, often have lips of vessels incised or notched across the top, and, in a rather uniformly small percentage, are stained on the inner surface with red hematite, the Nebraska culture pottery lacks all of these characteristics. The few cases where Nebraska culture and Upper Republican culture sherds have been found intermingled will be discussed later.

Before leaving the general subject of ceramics, however, the abundant tobacco pipes and the unusual human effigy heads of pottery must be considered. So far 14 of these effigy heads are known to have been recovered from Nebraska culture sites (fig. 30).³⁰² Suggestive of the human effigy heads recovered by Gilder and by Sterns is the face pipe (pl. 16, fig. 1, *a, b*) recovered by the Survey party in house 2 at the Gates site. These objects are different from anything yet reported from Nebraska and suggest the human effigy pots and pipes of the Arkansas region. Their use in the Nebraska culture is unknown, although Sterns in his unpublished work suggests that, judging from the roughly rounded necks of those he recovered, they may have been inserted into something, for example a doll bundle. The majority of the heads are broken off at the neck, and most of them seem too large to have ever formed part of a pot. They average around 2 to 3 inches in height and about an inch in thickness. With the exception of the Survey piece, they do not seem to have been used as pipes. The sketch (fig. 30) only suggests the great variation in technique and realism in the different specimens. With the exception of one small, beautifully carved piece of pink soapstone (fig. 30, *e*) all are modeled of pottery. One of them (fig. 30, *f*) has a fine white tempering suggesting ground shell; the tempering material of the others is not known to the writer. Whatever their function may have been, they represent an extremely interesting study in realistic and crudely conventional or symbolic art and indicate both the modeling abilities of the Nebraska culture people and their possible down-river affiliations. All 14 effigy heads so far recovered appear to have come from Nebraska culture house sites in eastern Nebraska. Sterns' five rather crude effigy heads (fig. 30, *i-m*) come from eastern Sarpy County, whereas the majority of Gilder's specimens come from cache pits in such houses in Douglas and north-eastern Sarpy Counties.

³⁰² This figure is based on photographs published by R. F. Gilder, 1911, pp. 250, 254, and on simple sketches of these artifacts in Gilder's private collection and in the Sterns collection at the Peabody Museum, Cambridge. In his unpublished work, 1915 a, pl. 73, Sterns illustrates nos. 9-13. Gilder, 1909, pl. 5, fig. 2, *c*, shows another pottery head very similar to one here figured (fig. 30, *h*), except that the eyes are raised instead of incised.

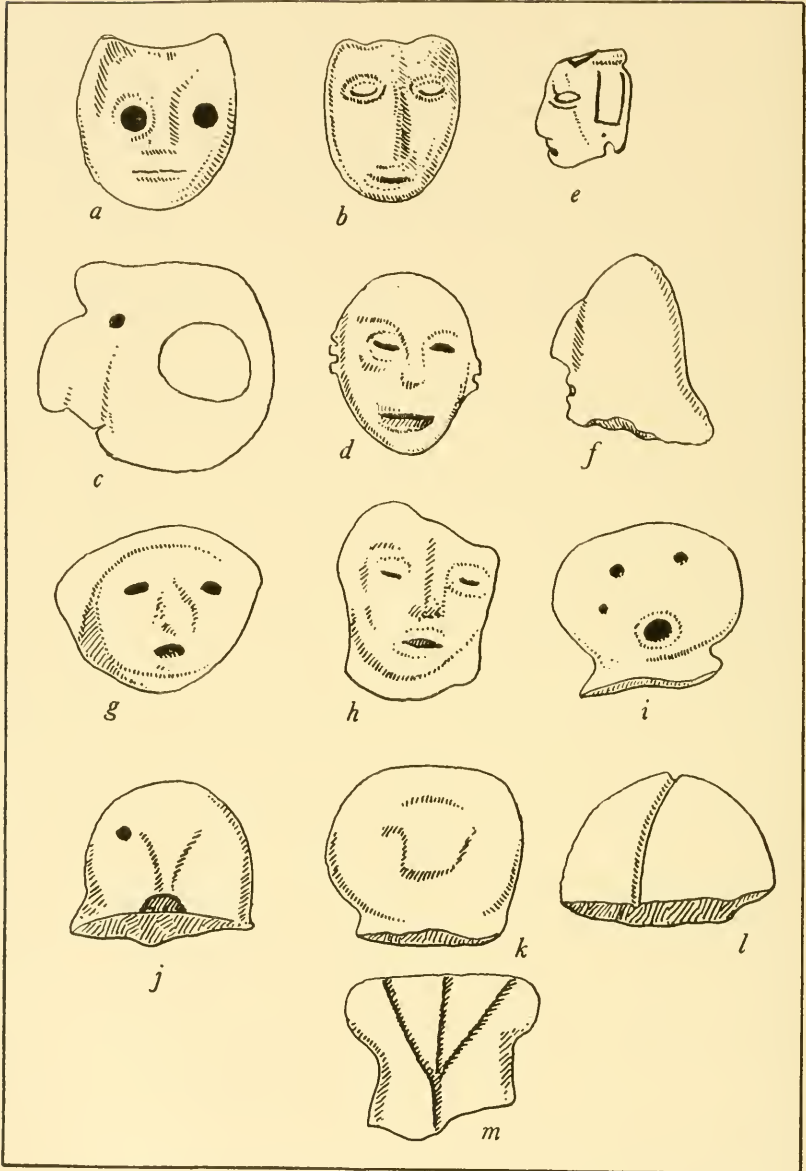

FIG. 30.—Effigy heads from Nebraska culture sites. *a, b, c, d, e, g, h* (after Gilder 1911); *f*, Gilder (private) collection; *i, j, k, l, m*, Sterns collection, Peabody Museum.

Tobacco pipes recovered from Nebraska culture sites are remarkable both as to quantity and quality. The 8 obtained by the Survey from houses at Rock Bluffs and the Gates sites are all of pottery, 6 of the bent tubular and 2 apparently fragments of straight tubular pipes (pl. 16, fig. 2). These have already been discussed in detail. Sterns obtained 40 pipes from Nebraska culture sites, 36 of pottery, 2 of limestone, 1 of pumice, and 1 of steatite. The pottery pipes are mostly of the bent tubular type, though they vary from almost a right angle to a straight line. One of these pottery pipes with a sharp elbow and incised parallel rings around the top suggests a common Iroquois type; one broken pipe has a human face in relief, suggesting a similar pipe obtained by the Survey, as does another of Sterns' semielbow pipes with incised turkey tracks; one pipe is modeled to represent a bison skull; another a bison hoof; another a human foot; another, a reptile with lumps all over its back, has its legs broken off; and still another suggests half a banana in shape. Evidently the bent toward modeling in the Nebraska culture evidenced in their pottery found even greater expression in effigy heads and pipes. The three pumice and limestone pipes are of the elbow type and resemble those already described from Upper Republican sites. The steatite pipe is of the platform variety with a flange around the top of the bowl and, as Sterns states, resembles the Siouan calumet. Sterns (1915 a, II, p. 239) found no catlinite pipes.

In the course of his excavations Dr. Gilder has obtained a large number of pipes, many of which, especially the most unusual, have been illustrated in his various papers already referred to. A characteristic pottery pipe, obtained by Gilder near Omaha, now in the Nebraska State Museum collections, is illustrated here with those secured by the Survey (pl. 16, fig. 2, m). In the Gilder collection in the Omaha Public Library, which contains material obtained mainly from Nebraska culture sites in the Omaha vicinity, are 26 pipes. Twenty of these are of pottery, 5 of soft stone, and 1 of steatite. Most of the pottery pipes are of the bent tubular type; 2 have the form of a bird with spread wings; 1 a bird with wings in place; 2 have incised designs suggesting birds; 1 is a headless animal, the bowl opening formed by the neck; and 1 is a well-modeled toad with knobs or "warts" all over his back; a similar toad pipe collected by Gilder has incised circles instead of bumps. The five stone pipes are of white, pink, and red "pipestone" (this may be chalk) and are of the elbow type very similar to those found in the Upper Republican culture site at Lost Creek. To judge from the published accounts and the available collections, the Gilder pipe material accords with that obtained by

Sterns and by the Survey parties. The bent tubular pottery pipe predominates, and modeling and incision are both employed on such pipes. Stone pipes are rather uncommon and in form suggest either those from Upper Republican culture sites or types more common in the eastern United States.

In sketching in the outlines of the remaining artifact complex characteristic of the Nebraska culture the specimens obtained by the Survey parties, already described in detail, will be used as a basis and additional types, described by Gilder and Sterns from similar sites, will be included. Artifacts of ground stone are not especially numerous in the Nebraska culture; they include a very few polished and partially polished celts (no grooved axes), discoidal hammerstones, pitted anvil stones, rectangular and "buffer" type shaft polishers of sandstone (the latter described by Sterns as the "ideal" type in this culture), small sandstone and pumice slabs used for grinding, limestone anvil for pottery (only one reported), and a few perforated pieces of limestone and calcite. Ground-down pieces of hematite and limonite "paint" are rather common. Chipped stone artifacts are numerous, chipped celts, arrowpoints, knives, delicately chipped plano-convex end scrapers, ovoid side scrapers, numerous sharp flakes used as knives, and a few T-shaped chipped drills are represented. The arrowpoints fall into two main types, a rather heavy triangular point (NBa) and a small, delicately chipped point (also NBa), which is often notched (NBa 1-4) (table 2). From his Nebraska culture sites Sterns collected 117 unnotched points (mainly NBa), 16 with 2 notches (NBa1), 5 with 4 notches (NBa4), and 9 with 5 notches (NBa3). An examination of his collection reveals the same division into large and small NBa types, and the same thing is shown in the points obtained by Gilder in a typical site on Ponca Creek (near Omaha).¹⁰³ Stemmed points occasionally occur in Nebraska culture sites but are very rare. Knife blades are about evenly divided between ovoid and diamond-shaped forms, only a few of the latter type being beveled. Sterns found two oval knives with small stems at one end.

Bone and antler artifacts are also abundant. Bison scapula hoes are fairly common, some of these having side notches near the blade end, indicating, according to Sterns, that they were fitted with straight hafts and used as spades. Many reworked fragments of broken scapula tools have apparently been employed for other purposes, such as skin scrapers. Sterns reports one digging tool made from a portion of bison skull, and Gilder (1926, p. 21) found one bison-horn spoon.

¹⁰³ Gilder, 1907, p. 713, fig. 48. The Gilder collection in the Omaha Public Library contains the same two main types of points.

The latter artifact may formerly have occurred in other Nebraska sites, but the material is very perishable. A few handles for stone artifacts have been found, Sterns obtaining a semilunar piece of bone with a slit at one end of the base, just the size of a flint knife blade, and a hole, possibly for a thong, near the other end; also a piece of perforated large mammal bone that might have been a small ax handle. In the Omaha Public Library collection are three sections of cut antler, each having a socket hole in one end and, in one example, a small perforation at the other. According to Dr. Gilder, who found them, one of these had an end scraper in place, one a small flint knife, whereas the one with a socket and perforation was without any attached stone artifact. If handles were commonly employed on Nebraska culture stone artifacts, the majority appear to have been of perishable materials. Bone awls were rare in the sites worked by the Survey, but many have been recovered by Gilder and Sterns. Examples from known Nebraska culture sites collected by Gilder and now in the Nebraska State Museum collections are illustrated here (pl. 18, fig. 1). Needles, i. e., awls with eyes, are rather rare in these sites. None were found by the Survey, and Sterns states that less than 10 percent of his awls had eyes. A few large picks of bison ulna have been found (pl. 18, fig. 1, *a*). Shaft straighteners of antler, with one perforation, are characteristic of the culture, one obtained by Gilder and one by the Survey being illustrated (pl. 18, fig. 1, *b, c*). Sterns found many of this type besides one made from deer bone and one from a section of bison rib. Cylindrical tapping tools or punches of smoothed and unsmoothed antler, antler gouges, conical antler knapping tools, a few combs of antler, and grooved deer jaws (sinew stretchers?) are all found in Nebraska culture sites. Bone and antler fishhooks are rather common, the smaller of these resembling bone fishhooks from Upper Republican culture sites, but many of them are very large and marked by notches at the bend of the shank.¹⁰⁴ The Survey parties obtained none of these from Nebraska culture sites, but both Gilder and Sterns found a number of them. Another unusual antler artifact is a small toggle-head harpoon, of which at least three have been recovered from Nebraska culture sites by Gilder.¹⁰⁵ The

¹⁰⁴ Gilder, 1926, p. 8, illustrates five of these rather remarkable fishhooks. Similar but less elaborate forms occur on the Upper Missouri, Will and Spinden, 1906, pl. 36, *s. t.*; in Kentucky, Moore, 1916, fig. 8; in Tennessee, Harrington, 1922, pl. 75, *f.*; in Iroquois sites in New York, Parker, 1922, p. 119, fig. 14, and elsewhere in the east and southeast.

¹⁰⁵ 1926, p. 26; also pl. 9, fig. 2, *e*, present paper, shows one of these found by Gilder, now in the Nebraska State Museum. The fact that they were toggle-head harpoons and not weaving or other implements was brought out by Wintemberg, 1912, p. 27.

occurrence of an indubitable harpoon of this type, perhaps used for large catfish and sturgeon, in prehistoric sites in Nebraska is indeed remarkable. Both Gilder and Sterns have found bone beads, pendants, and some bracelet fragments. One of the latter recovered by Sterns is noteworthy since it very closely resembles one found in the Upper Republican culture site at Lost Creek (pl. 10, fig. 2). The bracelet found by Sterns in a Nebraska culture house 5 miles north of Florence, Nebr., is cruder than the Lost Creek specimen but has the same form and perforations, with an incised hand on the outer surface showing a line at the wrist and having marked off finger nails. There is no circle in the palm of the hand.

The design of a spread hand marked with incisions and often having a circle or eye in the palm is found commonly on pottery and copper and stone objects in certain parts of the southeast. It is particularly characteristic of the Moundville culture in Alabama and also occurs in Mississippi and Tennessee.¹⁰⁰ It is undoubtedly significant that a considerable number of Gulf coast shells, including artifacts made from the shell of the large conch, were found in the ossuary site from which the Republican culture bracelet was obtained. This design motif is only a more specialized example of a number of generalized or attenuated southeastern characteristics to be noted in both the Nebraska and the Upper Republican cultures.

A few other problematical bone and antler artifacts have been found in sites of this culture, but these need not be considered here. Worked shell is also characteristic of the Nebraska culture. Numerous shell spoons, shell pendants with incisions suggesting birds and fish, simple triangular gorgets, clawlike pendants, and a few flat and disk-shaped shell beads have been found. One cut fragment of shell obtained by a Survey party at the Gates site suggests the tooth of a comb. Unworked mollusk shells are common in these sites, and most of these, as well as the worked pieces, seem to be of native fresh-water species. Of the textile arts the impression of a coiled basket recovered in house 2, Rock Bluffs, and a very few clearly delineated cord markings on pottery are the only remaining traces. A considerable amount of charred corn and some charred beans and sunflower seeds have been found in these sites, but so far no evidences of squash have been reported. Of animal remains found at these sites deer bones appear to be considerably more abundant than those of the bison.

We have already discussed in detail the six houses of this culture excavated by the Survey. During the expeditions of the Peabody

¹⁰⁰ Moore, 1905, pp. 133-136, 149, 174, 175, 240. Also see Shetrone, 1930, pp. 387-388, 395-399, 429.

Museum from 1912 to 1914 Sterns excavated in 27 of these lodge sites in eastern Nebraska, many being completely excavated and others sampled.¹⁰⁷ He states that [Nebraska culture] lodge sites extend along the Missouri for a distance of at least 175 miles, from Thurston County, Nebr., to Doniphan County, Kans., being very numerous in northeastern Douglas County and in Sarpy County, Nebr., and scattered elsewhere in this region. Such sites are usually near the flood plain of the Missouri River on the first or second bluffs, exceptional locations being ridges along the Papillion and Weeping Water Creeks. To these exceptions, on the basis of the Survey work, we may add that similar sites occur on ridges along the lower Platte and Elkhorn Rivers. Sterns also notes that the majority of such sites are either near springs or else close to glacial outcrops where springs may formerly have occurred. He points out that these sites do not occur in village groups but are always strung out in a line, even when located on a flat river bottom, as though adapted to location on ridges. Here again we may add that villages, such as those at the Rock Bluffs and the Gates site, are known but that the line formation is usually maintained. Isolated houses, sometimes half a mile apart, also occur, and close village formation is apparently not characteristic of the culture as a whole. Such a straggling and unorganized alignment of houses combined with their occasional location in sites poorly chosen for either observation or defense suggests, as Gilder has already pointed out, that the Nebraska culture flourished in times of comparative peace and security.

The surface indications of such sites, according to Sterns, are round depressions from a few inches to 4 or 5 feet deep, averaging 45 feet in diameter with a range in the sites he examined of 12 to over 60 feet in diameter. The deepest surface depressions are in the north. Occasionally such house pits are marked by a low embankment and often contain trees as large and as old as any in the region. On excavation the great majority of the houses investigated by Sterns proved to be rectangular in outline, although three were rounded. Sterns' method of excavation was very similar to the trenching methods employed by the Survey previously discussed in the present paper; hence our results are strictly comparable. In vertical section Sterns notes three layers, a dark stratum of recently accumulated soil averaging 15 inches in thickness with a range, including all sites, from 11 to 20 inches. He notes that the northern sites average nearly 5 inches

¹⁰⁷ This summary of house types is from Sterns, 1915 a, II. On pp. 194-195 Sterns gives the exact locations of these sites and refers to maps on which they are located.

thicker than the southern in this regard, which may indicate greater antiquity. The second stratum of jointed yellow clay, containing some masses of dumped ashes and charcoal, is apparently the remains of the earth roof. It averages 10 inches (range 8-16 inches). The third stratum is the floor of the old lodge with its accumulated debris, which averages 12 inches (range 9-16 inches). The total depth of the original excavation varies from $2\frac{1}{4}$ to $4\frac{1}{2}$ feet below the present ground surface. Of the sites excavated, those in the north average 1 foot deeper than those in the south, the two shallowest houses being in the extreme southern part of the area worked. Whether this variation might be due to environmental causes is an interesting point not discussed by Sterns.

The walls of 24 of the excavated lodges are straight and rectangular in outline, having rounded corners. The length of the short wall averages 25 feet (range 16-34 feet) and of the long wall 28 feet (range 21-40 feet). Sterns discusses at some length the possibility of conscious orientation of these houses with the cardinal directions and concludes that since a rectangular building can be only 45° off from true north, the general north and south alignment of these houses is accidental rather than purposeful. He notes that the subsurface walls of the lodges slope outward from the top about 10° from the vertical. In two sites the walls had been burned brick-red, perhaps to make them impervious to water. An entrance passage was present in about half these sites, the others apparently having roof entrances with ladders. The passageways noted ranged from 12 to 24 feet in length, but with the exception of the shortest all were over 20 feet long. They were 4 to 5 feet in width, and their direction and length was apparently determined by the local contour of the ground. They appear to have generally extended to the southeast, but no definite scheme was observed. Since the passageways had little or no slope, their length depended on the ground slope beyond the individual house.

The floors in some cases appeared to have been burned prior to occupation and, except for the areas around fireplaces and in corners, were largely devoid of artifacts. Sterns noted very few postholes, and these, he says, would accord equally well with either the historic earth lodges or with a gabled roof, their paucity favoring the latter explanation. As in the work done by the Survey, it is here that the trenching method employed by Sterns is weakest, and it remains to be determined whether complete excavation of such sites above the floor line with subsequent careful shaving off of the floor area might not reveal the plan of post foundation employed.

Small pits about 1 foot deep and 1 foot in diameter averaged three to a lodge (range 0-6). They occurred in any part of the floor and contained a few broken artifacts. Large pits averaging $3\frac{1}{2}$ feet deep by $3\frac{1}{2}$ feet in diameter (range $2\frac{1}{2}$ -6 feet in diameter and 2-5 feet deep) averaged 4 to a house, although one house had 10. About half these large pits were cylindrical and half were expanded at the bottom. The majority of artifacts recovered came from such pits, but to Sterns they do not appear as "caches", i. e., storage pits, but rather as rubbish pits. Gilder (1926, p. 19), who has probably dug in more of these pits than any other person, regards them primarily as storage places, and the writer is inclined to believe that such was their primary purpose, since the preparation of an interior pit for refuse deposition when the whole outdoor was available seems a pointless procedure. The occurrence of large deposits of clear white ash and numerous unbroken artifacts in such pits furthers this idea, as does their use by historic tribes as granaries and deposit places. It is certain that, when empty, they were often filled with refuse.

Sterns encountered only three lodges, in a group of six on Papillion Creek in Sarpy County, that were not square or rectangular. Two were circular, with diameters of 16 and 20 feet, and the third was elliptical, averaging 18 feet in diameter, all being rather small. The other lodges at the Papillion Creek site were not excavated by Sterns. Aside from their shape they were similar to the rectangular lodges and contained the same types of artifacts. It was in one of these houses that Gilder and Sterns encountered numerous cracked and scorched human bones on the floor and in cache pits, and in a cracked pot were fragments of human rib bones which had the appearance of having been boiled. (Gilder, 1913, pp. 107-116.) The small elliptical house combined with the presence of mutilated human bones calls very strongly to mind the lodge at the Saunders site partially excavated by the Survey. Further investigation at these two sites should go far toward clearing up this matter of ceremonial cannibalism or strange mortuary rites, whichever it may be. One other interesting feature of the round and oval houses reported by Sterns is the fact that this was the only site where bison bones were more numerous than those of deer. Sterns states that the form of these dwellings may represent a transitional stage in the development of the round historic earth lodge of the region or may merely be a modification resulting from their small size.

From the above condensed account of Sterns' findings it appears that the earth lodge of the Nebraska culture is characteristically rectangular or square, is semisubterranean, and may or may not have a long entrance passage. The occurrence of a few round lodges, in one case

at least used as a charnel house, is also noted. These conclusions are in almost complete accord with those of the less extensive Survey researches in such sites. Gilder has also described various Nebraska culture houses, but owing to incomplete excavation his earlier descriptions are seriously open to question and need not be considered here.

There remains to be mentioned the vexed problem of the methods of disposal of the dead practiced by the people of the Nebraska culture. The occurrence of some sort of charnel houses has been mentioned above, and the presence of scattered bones and partially articulated skeletons in natural hillocks or mounds associated with potsherds of the Nebraska culture type has also been touched upon in earlier sections. Fragmentary evidence of this sort obtained by Gilder, Sterns, and the writer, indicates that the people of the Nebraska culture exposed their dead, perhaps on scaffolds or in certain houses, and later buried them with a few scattered offerings in small elevations or ridges near the houses. That some of these hillocks may prove to be artificial rather than natural is a possibility, and until more careful excavation work in such sites has been accomplished we cannot tell whether the Nebraska culture carriers were actually mound builders or not. The occurrence of only a very few scattered human bones and offerings in such elevations, as was the case in the "mound" above the Walker Gilmore site previously described, suggests that the Nebraska culture people may have at times removed the bones of their dead and carried them away with them, as has been recorded, for example, among the Sisseton and other Dakota groups. (Bushnell, 1927, p. 26.) All that can be said at present is that these people exposed and dismembered their dead, seem to have kept the skeletal remains in their lodges, perhaps practicing some form of ceremonial cannibalism, and eventually deposited them in mounds, natural or otherwise.

In summing up the characteristics of the Nebraska culture in comparison with those of the Upper Republican culture, a few sharp differences as well as numerous similarities become apparent. Both have rectangular semisubterranean earth lodges as the main type of dwelling, and both occasionally used round earth lodges as well. However, the Nebraska culture lodges had only interior cache pits and often lacked a definite entrance passageway, whereas the Upper Republican culture house type, so far as known, had a definite four post central foundation, one or two post-lined entrance passages, and exterior as well as interior cache pits. Both cultures are characterized by the deposition of previously exposed human bones in ossuaries, but there is a possibility that the people of the Nebraska culture were

mound builders as well. In regard to pottery, the two cultures, so far as known at present, are quite distinct. On the other hand, the remainder of the artifact complex of the two is basically similar. Both cultures have tobacco pipes of pottery and stone, both have the two main types of arrowpoints already described,¹⁰⁸ the same types of flint knives and scrapers, the same types of bone and antler implements, and both worked shell in much the same manner. Differences appear in the fact that pottery pipes predominate in Nebraska culture sites, stone pipes in Upper Republican culture sites, and the artifacts of the former culture generally exhibit a greater richness and variety than do those of the Upper Republican culture. Indeed, if it were not for the striking difference in ceramics found at the two types of sites, it would be rather hard to draw a clear line between the two cultures. Yet this major difference, combined with the minor distinctions listed above, seems to justify their separation as distinct cultural entities. The similar evidences of relative antiquity observed in excavating both types of sites, combined with many close parallels in the content of the two cultures, strongly suggests that the two were contemporaneous in time and definitely reacted upon one another. The significance of this evidence will be discussed in the next section.

THE STERNS CREEK CULTURE

The cultural evidence revealed in the lowest stratum at the Walker Gilmore site (fig. 1, site 26, and pl. 19) is so different from the other known prehistoric horizons in Nebraska that it must be classed as a

¹⁰⁸ This uniform occurrence of two types of arrowheads, a larger and a smaller, in at least two prehistoric Nebraska cultures is significant. That the difference was functional rather than accidental is indicated by Bradbury, 1817, pp. 164-165, when he describes the arrows then in use among the Arikara: "To produce a more copious discharge (of blood), the heads of the arrows designed to be used in hunting are much broader than those intended for war. The heads of both are flat, and of the form of an isosceles triangle; the length of the two equal sides three times that of the base. In neither does the shaft of the arrow fill up the wound which the head has made; but the shaft of the hunting arrow is fluted, to promote a still greater discharge of blood." In a footnote he adds that formerly the Indians made arrowheads of flint or horn stone, but at the time of which he writes (1810) they purchased them from traders, who cut them from rolled iron or hoops. Dunbar mentions the grooved arrow shaft in use among the Pawnee but states that this tribe never followed the practice of making two kinds of arrows, one for war and one for hunting. (See De Land, 1906, p. 308.) This agrees with the archeological findings, inasmuch as two distinct sizes of arrowpoints have not been found on protohistoric and historic Pawnee sites, whereas the Arikara seem to have preserved an old differentiation between large "hunting" points and small "war" points noted in the two main prehistoric cultures so far distinguished in Nebraska.

distinct culture. At present this one site is the only place where this exact culture complex is known to occur, but there are some indications that it may be found across the Missouri River in western Iowa and possibly in other sites in eastern Nebraska. Since all the available evidence on the Sterns Creek culture has already been presented in the earlier section of this paper concerning the Walker Gilmore site, we need only list its main characteristics. Particularly striking is the evidence of small surface houses with thatched roofs, small posts and, perhaps, walls of bark. Equally distinctive is the pottery from the lower level, which appears to have had definitely pointed or conical bottoms, has no collar and no sharp angle between shoulder and rim, lacks any general body cord marking or incisions, lacks all secondary features, such as lugs or handles, is crumbling rather than flaking in texture and was apparently coiled rather than lump modeled (pl. 19, fig. 1). Its decoration is simple, consisting in a great majority of cases of delicate scallops around the outer edge of the rim, made with a blunt instrument or with the fingers, and in rare cases of a design on the neck made by single heavy cord impressions forming simple patterns. This pottery, although not very abundant, occurs in all the exposures in the lower level at this site and is both uniform and unique in type. The only other pottery artifacts recovered here were fragments of straight conical tobacco pipes. Of stone artifacts, only one excellently polished celt or ax fragment and a few simple hammerstones, a very few crudely chipped notched and unnotched arrowpoints, ovoid and retouched flake knives or scrapers, and one large crude pick or hand ax have been recovered. Bone and antler work, on the other hand, is excellent, including in the present list numerous awls or needles with eyes, antler picks and knapping tools, one bone bead and one perforated animal toe bone (part of a "ring and pin" game). Wood and shell occur in this horizon, the former material being definitely worked in a few cases. Especially notable is the presence of numerous squash and gourd remains but, so far as known, no evidence of maize. Likewise, the fact that deer bones predominate heavily over those of the bison in the refuse deposits is undoubtedly significant. Such in briefest résumé is the culture so far revealed in the lower strata at the Walker Gilmore site. It is remarkable for many things, such as its great depth of deposition, its occurrence under remains of the prehistoric Nebraska culture, and the unique nature, so far as Nebraska is concerned, of its cultural complex. Although this culture seems unique and somewhat out of place within the State, it has certain definite analogues elsewhere which will be discussed shortly.

SIGNAL BUTTE CULTURES (II AND I)

There are at Signal Butte at least four main cultural manifestations (components) representing four culture types (aspects) or subtypes. Two (Upper Republican and Dismal River) in level III, one (Signal Butte II) in level II, and one (Signal Butte I) in level I. In addition, the two upper levels (III and II) contain artifacts carried up from the exposed edges of the lower and older deposits. Regarding the most recent level of occupation (III), the essential characteristics of the Upper Republican culture in its various manifestations have already been discussed. The little known Dismal River cultural type will be referred to later. The middle occupation level (II), aside from intrusive artifacts from level I, is distinctive but as yet poorly defined. Most characteristic of this horizon are stemmed projectile points of medium size, with and without barbs (SCb2, SCA2) (fig. 7 and pl. 24, fig. 2, *e, f*). This type of point comprises 61 percent of all projectile points from this level. Those with straight bases are most numerous. On Signal Butte, however, this horizon is so limited that it must be found elsewhere in more abundance before it can be described as a major culture (or aspect). The cultural material from the lowest level (I), however, is so abundant and distinctive that it seems safe to designate it as a major culture, or aspect, under the name Signal Butte I.

Owing to the condensed presentation of this evidence in a previous section, only the major characteristics of the Signal Butte I culture need be recapitulated. Like Signal Butte II, the older horizon (I) lacks pottery. It is primarily a chipped stone culture but a number of ground stone artifact types also occur, particularly grinding stones, shaft polishers and, rather unexpectedly, grooved mauls and one ax with ground notches (pl. 25, fig. 2, *m*). The chipped flint industry is rich and is particularly characterized by the use of flakes, usually with excellent retouching. A large number of artifact types occur, especially planoconvex scrapers and chipped points (table 3). Among the latter a medium-sized to large lanceolate, or leaf-shaped, form greatly predominates (65 percent of all projectile points). One leaf-shaped type with a concave base (NAb3) comprises 34 percent of all the other types of projectile points. In outline, this type is similar to the Folsom type of point (NAb4) but lacks the longitudinal grooves (fig. 7, and pl. 25, fig. 1, *o*). Less numerous (28 percent of all projectile points) are three types (SCa2, SCA3, SCb3) of stemmed points, the majority of which also have stems with concave bases. The occurrence of many planoconvex graters and small flake drills

is also noteworthy. Plano-convex end scrapers are extremely numerous, and of three types, those with rough backs comprise 59 percent, those with retouched backs 31 percent, and those with definite stems 10 percent. Side scrapers are even more common, and of these 33 percent are planoconvex and 67 percent are retouched on both sides. Flake knives, always planoconvex, are very abundant and range from simple flakes with a use retouch on one or more edges, to a definite type of flat knife with a well-retouched back, a delicately retouched edge, and a curved (plane of fracture) under surface (pl. 25, fig. 1, *w-s*). Workshop materials are abundant in this level, and a wide range of materials are represented. Bone work is not overly abundant, but several rather distinctive types are present, including an awl made of split bone or antler with a short, shouldered point; large split bone knapping tools; heavy, crude bone gouges; and polished bone fragments with incised geometric designs. Some worked shell occurs. Small, potshaped storage pits and round, often stone-fired fireplaces are the only structural features. This, very briefly, sums up the salient characteristics of the Signal Butte I culture. In the next section the sequence of artifact types from level to level on Signal Butte will be touched upon.

OTHER SITES

In regard to the three sites on the Dismal River our present knowledge is too scanty to determine whether a distinct culture is represented here or not. Two distinctive pottery types occur at these sites, (a) a thick brown hole-tempered ware with deep markings on the outer surface (pl. 22, fig. 1, *a, b, c, e*), and (b) a rather thin gray-black smooth ware which is tempered with fine sand (pl. 22, fig. 1, *d, f-m*). On the Dismal River a number of European objects have been found associated with both these types of pottery on the surface, but whether all three are contemporaneous is uncertain. In western Nebraska, at Kaighns Point, 100 miles to the west, the two ceramic types were again found associated, and the gray-black ware (b) occurs in association with more abundant Upper Republican type pottery in the third level (III) at Signal Butte, where it is prehistoric (pl. 24, fig. 2, *b*). It has been suggested, on the basis of historical and traditional evidence, that the Dismal River sites were occupied by the Comanche in early historic or protohistoric times and that one or both of these ceramic types may pertain to that tribe. Since no records of Comanche pottery-making exist, the point is interesting.

All of the Nebraska cultures so far distinguished have now been mentioned. Obviously many of these, indeed most of them, are very

inadequately defined, and of none can it be said that it is known in full detail. That still other cultures remain to be added to this record is indicated by numerous unclassified archeological sites, many of which have been mentioned. The occurrence of artifacts associated with various extinct species of bison at Cumro, Grand Island, Spring Creek, and possibly Bird Creek has been mentioned. In each of these finds, however, the artifact content has been too limited to do more than suggest cultural affiliations. The true Folsom culture, revealed at the Lindenmeier site in northeastern Colorado, has not yet (1935) been encountered in situ in Nebraska.

CULTURE SEQUENCE AND DEVELOPMENT IN NEBRASKA

So far there have been four primary methods of establishing culture sequence in Nebraska, the first based upon the degree of European contact exhibited in aboriginal sites; the second upon the superimposition of culture layers, or stratification; the third upon the association of distinct types of artifacts with extinct animal species; and the fourth upon the occurrence of artifacts in deposits of determinable geologic age. The first of these permits a division of contact sites into historic, i. e., documented, and protohistoric sites which show evidences of white contact but are not recorded in the annals of exploration. In general, such protohistoric sites are older than the historic sites, and in a few cases their relative age can be determined by the fact that they contain a few white trade articles but no horse remains. Prehistoric sites that show no evidences of any such alien contact are still older. The value of stratification in determining sequence is obvious, and in this regard we are fortunate in having two prehistoric stratified sites strategically located in extreme eastern and western Nebraska. The third method, i. e., the association of definite artifacts with extinct fauna, has been a much emphasized development of the last few years. Unfortunately, the uncertainty which as yet exists concerning even the relative time of extinction of many animal species has made this method of dating unsatisfactory. In final analysis objective dating of such associations must rest upon the fourth method of determining time sequence, i. e., their occurrence in horizons of known or determinable geologic age. Dendrochronology and fossil pollen analyses, which have recently been found to be applicable in parts of the Mississippi valley, may prove highly valuable in portions of the Great Plains as well. Methods of determining the finer time periods in the North American Recent and Pleistocene periods are still in an experimental stage, and on their

development depends any worth while relative dating of the earliest chapters of human history in the New World.

Applying the first three of these methods to the available archeological evidence in Nebraska, the following culture sequences are suggested (table 7). The more or less debatable geologic age of certain of these horizons or associations will be discussed later.

On the historic level the outlines of Pawnee archeology are already known, whereas that of the sedentary Siouan peoples, Oto, Omaha, and Ponca, are still obscure. From historic sources we know that the

TABLE 7.—*Sequence of Cultures in Nebraska (and Northern Colorado)*

[East→]	Glacial area	Loess plains	Sand hills	High plains [→West]
Historic	Sedentary Siouan	Pawnee	Dakota, Arapaho, and Cheyenne	
Protohistoric	?	Pawnee	Comanche	?
			Dismal River (poorly defined)	
Prehistoric	Nebraska Sterns Creek	Upper Republican	(Signal Butte III) {	Dismal River Upper Republican
(Walker Gilmore site)				Signal Butte II— (poorly defined)
				Signal Butte I
			Artifacts associated with extinct bison (geologic age?)	
			Folsom (Northern Colo.) (geologic age?)	
			PLEISTOCENE (at present an indefinite transition)	

latter tribes probably entered Nebraska during the eighteenth century, occupying the richest portion of the State just west of the Missouri River, apparently without any determined opposition on the part of the Pawnee. Since the Pawnee immediately to the west had long preceded them in Nebraska, were superior to them in numbers and organization, and later dominated them politically, such a late and apparently peaceful occupation is remarkable. The fact that this rich eastern strip seems at no time to have been occupied by the Pawnee suggests that the Omaha, Ponca, and Oto were merely the last of a series of related peoples to hold this region. Otherwise it is inconceivable that the Pawnee would not have extended their territories to the Missouri at some point in its long course along the eastern

boundary of the State. The Pawnee, as has previously been stressed, seem to have been the oldest Nebraska tribe. Apparently moving up from the south in the rather dim past, they have occupied the heart of the Nebraska region from the earliest dawn of recorded history. As Wedel has suggested, they appear to be a people originally of southeastern woodland cultural antecedents that had become habituated to a settled horticultural life along the lesser rivers of the central loess plains. The time of their arrival in Nebraska is unknown, but from the archeological record it must have been considerably prior to the historic period. Of the nomadic buffalo-hunting peoples of Siouan and Algonkian speech, namely, the Dakota and the Arapaho and Cheyenne, the historic record indicates recency of occupation along the western borders of the State.

During the protohistoric period, roughly between 1540 and 1682, Pawnee culture seems to have achieved its highest development. The known protohistoric Pawnee villages are larger, the house types in closer conformity to native ideology and sometimes more elaborate, and the ceramics and other artifacts of better quality than at any other period. The pottery from protohistoric Pawnee sites is the finest known in the Nebraska region and is as advanced and well finished as any known Arikara or Mandan wares. This seems to be the type of culture so briefly mentioned by the chroniclers of the Coronado expedition, and archeology is thus able to confirm their reports of large, settled villages west of the Missouri, whose numerous inhabitants were horticulturists and in no sense nomadic hunters. Many things remain to be determined concerning this culture, as, for example, the methods of burial employed, the range of the culture in space, and the exact transitions occurring between the historic sites on the one hand and the prehistoric (Upper Republican) culture on the other. Nevertheless, the work already accomplished at the Burkett and Schuyler sites is sufficient to indicate the high level of Pawnee development just prior to the acquisition of the horse, and its subsequent decline. So far nothing is known concerning either the sedentary Siouan peoples of the east or the peoples of western Nebraska during this period. From historical sources it is known that the Comanche occupied the sand-hill region of central Nebraska at about this time, coming in from the west and moving out toward the south. Archeological investigation to date adds little to the incomplete historic record in this regard, except that sites marked by unique pottery types do occur on the Dismal River in the heart of the sand-hill region, in places where the Comanche are reported to have been settled. At the present time only the protohistoric Pawnee culture clearly bridges

the gap between the known historic and the entirely prehistoric horizons.

The prehistoric period in Nebraska has been the main concern of the present paper. It extends from 1541 for an indefinite period back into the past, a period for which culture sequences are being established but for which even relative dates do not yet exist. In 1922 Fowke concluded that not a single bit of human evidence revealed along the Missouri River in northern Kansas and Nebraska was older than 10 centuries. Like Fowke, the writer admits that at present most time estimates are mere guesses, yet his own opinion regarding the earliest evidences of man in the region would change the centuries of the former's estimate to millennia and regard this as an ultraconservative estimate.

In considering the prehistoric cultures of our area from east to west, the Nebraska culture must be discussed. So far as known this culture is entirely prehistoric and coincides rather remarkably with the historic range of the sedentary Siouan tribes. Considering the average accumulation of 15 inches of soil in the house pits of this culture subsequent to their abandonment, the culture is not extremely recent, but the transposition of such an accumulation into terms of years is not yet possible. The earth lodges, although predominantly rectangular in outline, are in a few cases round, suggesting a possible transition to the historic type in the region. Of all the strictly prehistoric cultures in Nebraska, this is perhaps the most advanced. It also shows more contact with other peoples to the south and east, as evidenced by modeling in pottery, clay pipes, human effigies, and the occurrence of intrusive ceramic types. From the scattered and often indefensible nature of the isolated houses or small, strung-out villages it would appear that the culture flourished in a period of relative peace. From the abundance of charred maize and other vegetal remains in many of these sites, the abundance of bone digging tools, and the quantity of pottery found, a sedentary and horticultural life is also indicated. There is a suggestion that mound burial was in vogue, at least the previously exposed dead were deposited in small natural eminences, and it is possible that careful excavation may establish the artificial nature of some of these. Along the Missouri River the Nebraska culture was preceded by a quite different sort of occupation, that of the Sterns Creek culture people. To the west another prehistoric people comprising the Upper Republican culture seem to have been generally contemporaneous with the Nebraska culture. It remains to be determined whether the Nebraska culture represents an earlier Siouan occupation of the glacial area in the State or whether some

other group is represented here. This should become clear when the archeology of the historic and protohistoric Siouan tribes has been undertaken. One significant fact, however, is already evident, and that is the dissimilarity that exists between the Nebraska culture and the later Pawnee cultures. This is particularly marked in the pottery characteristic of these cultures but extends into other cultural features as well.

The Upper Republican culture, like the above, is marked by numerous small, scattered villages which exhibit no attempt at close organization or defense precautions. The remains of this culture seem to center on the Republican and Loup Rivers in the heart of the historic Pawnee territory but extend still farther to the west and north. Apparently, they occur in Kansas as well, but the archeology of this State is still obscure. From the amount of subsequent accumulation of unmixed soil over certain of the abandoned sites an antiquity rather similar to that of the Nebraska culture is suggested. This belief in contemporaneity is strengthened by certain general similarities in house type, disposal of the dead, and the nature of the total artifact complex (excepting pottery) that exists between the two cultures. Moreover, both Sterns and the writer found a few Upper Republican type rim sherds mixed in with the typical Nebraska culture remains on the plowed surface at the Walker Gilmore site.

At the Butte site in extreme northeastern Nebraska the relationship between these two types of pottery appears to be even more complex, suggesting that some sort of cultural amalgamation may have occurred in the north. In this region the range of the sedentary Siouan tribes and the Caddoan Arikara seems to have overlapped in protohistoric and prehistoric times. Omaha ethnology strongly indicates early and close contacts with the Arikara in this area (Fletcher and La Flesche, 1911). The latter were evidently derived from the generalized, prehistoric Upper Republican culture and, if the historic Omaha and Ponca prove to be derived from the prehistoric Nebraska culture, such a fusion would be expectable. Elsewhere the ceramic complexes of the Nebraska and Upper Republican cultures differ very markedly, and since slight though seemingly persistent differences occur in their remaining cultural content, it would appear that the two had persisted for some time side by side, very much as the Caddoan Pawnee and the sedentary Siouan tribes did in the historic period. In both cases there appears to have been mutual borrowing of traits, but the two cultures, at least in the central and southern portions of Nebraska, seem to have maintained their own integrity.

It has been stated that the Upper Republican culture probably represents a prehistoric stage in Pawnee development. This is indicated not only by the fact that the ranges of the two cultures coincide, but also by the fact that a transition from Upper Republican culture to protohistoric Pawnee and finally to historic Pawnee cultures is apparent. This is particularly marked as regards the development of house types and ceramics.

The predominant Upper Republican culture house type appears to have been a small, semisubterranean earth lodge with a four-post central foundation, covered entryway (or entryways), and square or rectangular outline with rounded corners. At the same time one round and one intermediate earth lodge pertaining to this culture have been uncovered at Sweetwater (1932). The former of these, except for smaller size and deeper floor, is identical with the later protohistoric Pawnee earth lodges. The latter are round in outline, about half as deep as the earlier type, and considerably larger, but are otherwise very similar, having the same four-post central foundation, outer circle (or circles) of posts and a post-lined passageway. The historic Pawnee earth lodge is also round, is nearly on the surface of the ground, and has from four to eight central posts instead of the almost universal four of the earlier types. In spite of this lapse from the old pattern in building such lodges, the present Pawnee still refer to only four house posts in their ceremonies. The outer circle of posts and the post-lined passageways of the historic houses are the same as those of the earlier types. There appears, then, to have been a consistent development from the small, deep, square or round earth lodge up to the large, slightly subsurface, round earth lodge of historic times. Although the discovery that the square earth lodge is an earlier type than the round lodge in central Nebraska may seem surprising, it is in accord with the findings of Sterns in eastern Nebraska, where the predominantly rectangular dwelling of the Nebraska culture precedes the round earth lodge of the historic Siouan tribes. Of these two prehistoric house types, that of the Upper Republican culture shows the most direct relationship to the historic Pawnee earth lodge. It would take us too far afield to discuss the possible reasons for the occurrence of this earlier rectangular type of dwelling in Nebraska. It seems a promising hint that in the prehistoric Caddoan cultures of southwestern Arkansas both the round and the square earth lodge has been reported (M. R. Harrington, 1920, pp. 256-259, 291-297) and that certain of these closely approximate the Upper Republican (or prehistoric Pawnee) culture type of dwellings in central and southern Nebraska. The point that is stressed at this time, however,

is the strong probability that the historic Pawnee earth lodge is a direct outgrowth of the house type found at Upper Republican culture sites.

Equally interesting is the probability of the development of historic Pawnee ceramics from the types represented in the Upper Republican River culture. In regard to the predominant gray to buff tone of the ware, the use of collars or overhanging rims, the decoration of such rims with incisions, and the occurrence in all three cultures of a small proportion of buff ware with a red hematite slip or pseudoslip on the inner surface, the Upper Republican, protohistoric and historic Pawnee are the same. It is also notable that the Lost Creek focus of the Upper Republican culture has a very high proportion of collars but no loop handles (the Sweetwater focus has a few), the protohistoric Pawnee ware also has collared rims but in many cases substitutes a series of loop handles extending from flaring lip to neck, whereas the historic Pawnee rim type returns to a predominantly collared type but retains in many cases attenuated series of loop handles extending from lip to neck as in the protohistoric stage. Presumably, the function of the overhanging collar is to facilitate the attachment of thongs or cords for suspension; hence the development noted in the three wares seems logical. The prehistoric people depended almost entirely on such collars, the protohistoric people retained these or substituted the more decorative row of loop handles, and the rather decadent pottery of the historic period not only has the accentuated collar but also retains in many cases the series of loop handles of the intermediate stage. In all three wares incised decoration characterizes the neck or collar of the vessels. This decoration is simple and geometric in the Lost Creek focus, adds cord marking to incising in the Sweetwater focus, runs to great elaboration of incised design on handles and rims in the protohistoric period, and becomes more simple, conventional, and very careless in the historic period. Since at the present time we have only sampled sites of these three cultures, it is not to be expected that a full series of intermediate stages between all of them would be represented in the present collections. As transition sites are excavated the writer believes that a clear, unbroken line of ceramic and other development will become evident. If such proves to be the case, it will be permissible to change the term Upper Republican to Prehistoric Pawnee culture, although further research may definitely connect this early culture type with prehistoric Arikara, Wichita, or other cultures, in which case a more inclusive term may be desirable.

Other artifact types in the three cultures likewise show many basic similarities, and it might be possible, even with our limited data, to

trace the development of various types from the early to the late periods. One marked break between historic and prehistoric cultures is the method of interment practiced by each, the people of the first period exposing their dead and eventually depositing them in hilltop ossuaries, whereas the historic Pawnee buried individually in hilltop cemeteries. When Pawnee burial sites of the protohistoric period are explored, it is probable that a transition between the two types can be demonstrated. It will suffice for the present to point out the strong probability that the Upper Republican culture, which undoubtedly precedes the historic period by several centuries, represents the prehistoric stage of Pawnee development in Nebraska.

In the Sterns Creek culture we have a still earlier culture type in eastern Nebraska. Direct superimposition of layers proves that it is considerably older than the Nebraska culture and presumably than the Upper Republican culture. There is very little resemblance between the Sterns Creek culture and the two prehistoric cultures that succeed it. Since the Sterns Creek culture has so far been reported from only one site on the extreme eastern border of Nebraska and bears little resemblance to any later cultures in the State, it now appears as the westernmost thrust of an early trans-Missouri River culture whose roots will be found to the east of our region. Of its possible northeastern affiliations we will speak in a moment. It assumes importance as the oldest known horizon containing evidence of horticulture and the use of pottery so far distinguished in Nebraska.

The stratified site at Signal Butte in the extreme western part of the State presents a similar situation, involving, however, different prehistoric cultures than those represented at the Walker Gilmore site. At Signal Butte a subtype (focus) of the Upper Republican culture, mixed with ceramics and other artifacts of the poorly defined Dismal River culture, overlies two distinct horizons (Signal Butte II and I), each of which is totally without pottery. The wider affiliations of the upper level (Signal Butte III) cultures have already been discussed and the essential characteristics, so far as known, of the two lower and older cultural horizons listed. Since this remarkable site gives a favorable opportunity to demonstrate cultural changes occurring at definite intervals over a long space of time, an attempt has been made to point out the major cultural trends from older to later horizons on the butte. These can be noted in the earlier and more detailed section on Signal Butte, but a brief recapitulation may make them clearer.

In general features, there are a few definite changes from bottom to top. Signal Butte I has no definite burials so far as known, Signal

Butte II yielded no human skeletal remains at all, but level III contained partial and infant burials in crude cists, and a seated adult burial. No dwelling remains were found in any level. Signal Butte I has deeper fire pits and small, often stone-lined, storage pits. Shallow fireplaces and irregular storage pits occur in levels II and III. Ceramics are entirely limited to level III, suggesting that pottery was introduced into the western plains in relatively late prehistoric times. Signal Butte I is characterized by a relative abundance of fragmentary grinding slabs and a few pestles, shaft smoothers, grooved mauls, and a notched ax. Ovoid lap stones occur in Signal Butte II, but in general the peoples who occupied levels II and III seem to have picked up the majority of their larger stone artifacts from the outcrops of level I. This is one of several indications suggesting that occupations II and III were sporadic and transitory compared to the long, continuous inhabitation of level I.

A marked change in types of projectile points occurs on the butte. The people of Signal Butte I preferred a leaf-shaped point of medium to large size, especially one with a concave base, very similar in outline to the Folsom point (pl. 25, fig. 1, *o*). This level I type, which occurs only occasionally as an intrusion in the upper levels, links Signal Butte I with other, and presumably earlier, cultures. It is the only type other than the typical, longitudinally grooved, Folsom type, so far known to occur in the Lindenmeier Folsom site in Colorado. On the other hand, the Signal Butte I people also used a smaller number of medium-sized to large stemmed points (pl. 25, fig. 1, *a-d*). This is a connecting link with the later Signal Butte II horizon. In Signal Butte II, the predominant projectile point is a medium-sized to large stemmed, and often barbed, point (pl. 24, fig. 2, *e, f*). By the time of the level III occupation, tiny, thin, triangular points, often with two notches, were predominant (pl. 24, fig. 1, *h, k, p*). Thus there is a definite change from the larger, leaf-shaped points, through medium-sized stemmed points, to the small, delicate, triangular points so common in the later prehistoric (Upper Republican and Nebraska) and historic cultures (Pawnee and Arikara). The common, planoconvex end scraper shows a similar transition; in Signal Butte I a coarse type with an unretouched back predominates, in Signal Butte II end scrapers with unretouched and retouched backs are about evenly divided, and in level III those with retouched backs predominate. The occurrence in level III alone of the diamond-shaped, beveled knife is another link with the late prehistoric horizons (table 3). In the types and abundance of side scrapers, end scrapers, retouched and unretouched flake knives, stone drills with a tiny point,

and small, planoconvex gravers there is a strong linkage between Signal Butte I and the recently defined Folsom culture in northern Colorado. It is interesting that some ground stone and mineral paints occur in all these horizons, including the Folsom culture. On Signal Butte, the bone and antler work of the three levels is not particularly distinctive, except that a rather unique type of split awl and bone gouge (pl. 25, fig. 2, *a, c*) occur in Signal Butte I. These linkages, especially as concerns flint implements, covering very considerable time periods, tend to establish definite typological sequences in the prehistoric chronology of central North America. The prospect thus revealed encourages one in thinking that the time when the archeology of this great area will emerge from the status of obscurely defined "cultures" into a sequential record of human development is not so very far in the future.

The various scattered finds of artifacts occurring in association with extinct animals, or in geologically old deposits, that have been reported from Nebraska and immediately adjacent areas within the last 5 or 6 years are hard to place culturally. This is primarily due to the paucity of cultural material from such sites. Considering this problem primarily from a typological angle, i. e., the apparent relationship between these isolated artifacts and those in well-defined cultural associations, the following relationships seem indicated to the present writer.

The chipped point from Cumro, Nebr., is of the so-called Yuma type without the narrowed stem (ND, fig. 7, and pl. 7, fig. 1, *e*). It does not fit into any known cultural horizon at the present time. The Yuma type of point often occurs in association with Folsom type points on blow-out sites as in Yuma County, Colo., and at Clovis, N. Mex., but in the work so far accomplished in the Folsom living level near Fort Collins no Yuma type points have yet come to light. It has been suggested that the Yuma point is in reality a knife used by the Folsom people, and this may be demonstrated by later excavation at the Lindenmeier site or elsewhere. Renaud (1934 *b*, p. 2) argues on typological and technical grounds that the Yuma type preceded the Folsom type, but to date there is no stratigraphic evidence whatsoever to support this view. Folsom type points have been found definitely associated with extinct bison (Folsom), a musk ox-like animal (Guadalupe Mts.) (see Howard, 1932, p. 14), and the mammoth (Dent), whereas the Yuma type of point has so far only been found in association with extinct bison (Cumro?, Spring Creek), but, as previously stated, in our present state of knowledge such considerations should not be given too much weight. The problem of relationship and (or) se-

quence of Yuma and Folsom type points is still an open one. In this regard it should be mentioned that at least one typical Yuma point (NDa) was found beneath the surface on Signal Butte. (Examined by the writer in the collection of the finder, Ray Swanson, Scottsbluff, in August 1931; see also Renaud, 1934 a, p. 39.)

In the bison quarry below Signal Butte, on Spring Creek, Schultz found a typical Yuma point (NDa) in association with two, ungrooved, leaf-shaped points (NAb 1-3, exact classification uncertain owing to broken bases), a stemmed point (SCa3), and a planoconvex, end scraper with a rough back. Barbour and Schultz (1932 b) classify the Spring Creek artifacts as of a "Pre-Folsom Culture" but, for the following reasons, I am unable to agree with such a classification. With the exception of the Yuma type point the remaining definite artifacts from Spring Creek all fit into the Signal Butte I artifact series (see table 3, p. 90), and, as previously noted, the Yuma type of point has been reported from Signal Butte as well. This definite association in the Spring Creek quarry between the Yuma type of point (NDa) and a stemmed point (SCa3) seems very significant. On Signal Butte it is clear that stemmed points are in a minority in Signal Butte I and come into greatest vogue in Signal Butte II, whereas so far they are unknown from the true Folsom culture. The inference is obvious that the stemmed type is generally a later form than the leaf-shaped. However, the inclusion of a definite Yuma (NDa) point, which at best is very rare in any Signal Butte levels, with other types which are common in Signal Butte I, suggests that culturally the Spring Creek artifact complex may be somewhat earlier than Signal Butte I, but is probably later than the true Folsom culture. This suggestion is supported by the fact that the Spring Creek bison are of an extinct species, whereas the fragmentary bison remains on Signal Butte cannot be distinguished from those of the recent bison. It should be remembered, however, that *Bison bison* apparently lived in the late Pleistocene as well. (Romer, 1933, p. 70.) As to geologic age, Lugn (1934) has recently suggested that these Spring Creek deposits belong to a "post-Kansas pre-Wisconsin" Pleistocene horizon. In the light of the marked cultural associations between the Spring Creek artifacts and those from Signal Butte I, this dating seems improbable unless the lowest horizons on Signal Butte are much older than is believed at present. Owing to the importance of the problems involved, the present writer believes that more detailed geologic evidence must be presented than is now available (Barbour and Schultz, 1932 b, and Lugn and Schultz, 1934) before this pronouncement can be unreservedly accepted.

The two chipped points found in association with extinct bison near Grand Island (Schultz, 1932) are suggestive of the Folsom type (NAb₄) but lack the fine retouching and complete longitudinal grooves characteristic of typical Folsom points. They fit into the Signal Butte series fairly well (NAb₃) but have a partial, longitudinal groove which is lacking on most of the Signal Butte I points of similar shape. I am inclined to regard them as transitional between Signal Butte I and Folsom.

The Angus find (Figgins, 1931) is still too incompletely authenticated to make cultural comparisons worth while. The scanty material from the Cape site near Dalton, Nebr. (Bell and Van Royen, 1934, p. 67), contains only one definite artifact type, a planoconvex, end scraper with an unretouched back, which agrees closely with the predominant type of end scraper from both Signal Butte I and the Folsom culture (Lindenmeier site). It may well be significant that Bell and Van Royen (1934, p. 69) tentatively suggest that the horizons where these finds occur fit into the same periods of Sears' chronology (1932, p. 621) that have been suggested for Signal Butte I. The two large points (NAb₄) found in association with mammoth remains near Dent, Colo. (Figgins, 1933), suggest knives or spears of the Folsom culture. Rather similar large leaf-shaped blades occur in Signal Butte I (pl. 25, fig. 1, *g*) but lack any longitudinal grooves and do not seem to be as delicately retouched. The main characteristics of the recently discovered Folsom horizon near Fort Collins (Roberts, 1935) have already been described, and the rather marked relationship between this culture and that of Signal Butte I commented upon. No definite geologic age has yet been assigned to either the Dent or the Lindenmeier site, but they can probably be correlated either with the ancient terrace system of the South Platte or with late Pleistocene horizons in the Medicine Bow region of Wyoming.

It is already certain that the human record in the Great Plains extends far back into that still obscure period between the beginning of the Recent and the close of the Pleistocene. Some believe that it extends well into the latter period. The last 5 years have opened new vistas in the human history of the region and there is no reason why subsequent years should be less fruitful.

CULTURAL AFFILIATIONS WITH ADJACENT AREAS

Considering the present status of archeological knowledge concerning the States bordering Nebraska, it is obviously premature to attempt any detailed cultural comparisons. Of South Dakota, Wyoming, Colorado, Kansas, and Iowa, only the last has been at all clearly

defined in regard to the general distribution of the prehistoric cultures within its boundaries. Of the other States we know something concerning isolated sites or limited areas, but as a whole they represent glaring blind spots in the field of archeological vision. Such being the case, all that the following purports to be is a rapid and admittedly incomplete sketch of such salient points in the archeology of the adjacent States as seem at present to have a direct bearing on the problems discussed in this paper.

Kansas, to judge from the scattered literature available, is an extremely promising archeological field which has to the present received nothing even approaching systematic investigation. However, interesting features stand out. Particularly noteworthy is Udden's excellent description and illustrations of a protohistoric village site on Paint Creek in McPherson County.¹⁰⁰ This site is marked by low mounds of refuse apparently similar to those at the Burkett site in Nebraska, and the culture revealed at the Paint Creek site also strongly suggests the protohistoric Pawnee culture. Pottery was abundant at the site, and certain rim sherds figured are definitely of the advanced and complexly incised protohistoric Pawnee type. In addition, a small proportion of sherds with red stain on the concave surface were noted. The occurrence of a few sherds suggesting flat-bottomed pots and some with elaborate incisions on the body tends to set the Paint Creek site somewhat apart, but the remainder of the Paint Creek artifact complex seems very similar to the protohistoric Pawnee culture in Nebraska. The protohistoric age of the Paint Creek site is indicated by the absence of white man's artifacts except for what is apparently a small piece of chain mail found 6 inches below the surface of one of the mounds, and two blue glass beads which were also found at the site. From Udden's very clear and dispassionate treatment of these finds it would seem that their authenticity may be fully accepted. This discovery of very early white contacts in a Kansas site so similar to the protohistoric Pawnee villages in Nebraska reinforces the conclusions independently arrived at that this culture was flourishing about the time of the Coronado expedition of 1541.

In Brower's brief description of the Griffing site in Riley County, Kans., there is a strong suggestion of the Upper Republican or "pre-

¹⁰⁰ J. A. Udden, 1900. Hill and Wedel have since investigated this site. Wedel corroborates its protohistoric age but finds such distinctive differences from the Lower Loup Aspect that he has designated the cultural type as the Great Bend (Smoky Hill) Aspect, of the Central Plains Phase (Wedel, 1935, III and IV). Wedel's papers, including 1935, II, mark a front-line attack on the important problem of Kansas prehistory.

historic Pawnee" culture.¹¹⁰ To judge from the illustrations, the diamond-shaped knives, end scrapers, small triangular notched points, shaft polishers, flint celts, bone fishhooks, bone beads, and shell beads from this site are very similar to those from Upper Republican culture sites in Nebraska. The pottery from the site, though inadequately described or figured, suggests a similar relationship. In northeastern Kansas a number of historic, protohistoric, and prehistoric cultures are evidently represented.¹¹¹ Harrington, on the basis of collections and data furnished by Edward Park, of White Cloud, Kans., suggests that the "latest culture" in northeastern Kansas is Siouan (Kansa or Osage) in origin and finds it closely similar to the "top layer culture" overlying the Ozark Bluff Dweller culture in Arkansas.¹¹² From the work of Sterns it is obvious that the Nebraska culture is also represented here. One is much tempted to regard the "latest culture" as a development from the Nebraska culture, a sequence which would involve important theoretical implications. However, the literature on this very important corner of Kansas is so fragmentary that it seems futile to attempt definite correlations until more systematic excavations and publications are available. The same can be said regarding the highly suggestive but tantalizingly incomplete data available in regard to northern Oklahoma and southern Kansas, where important early Caddoan cultures seem indicated but are not yet defined in any clear or objective manner.¹¹³ Thus any attempt at present to trace Nebraska or other northern cultures toward their apparent sources in the south and east meets with little success, owing to the lack of systematic field work and publication in the important intervening areas.

Thanks to the careful survey work of Dr. Charles R. Keyes, the general distribution of prehistoric cultures in Iowa has been well outlined.¹¹⁴ Up to the present the main emphasis in Iowa has been on survey work and relatively few scientific excavations have been made. Nevertheless, through careful surface surveys, study of local collections, and painstaking compilation of all newspaper accounts and

¹¹⁰ Brower, 1898, p. 25. This report, and that by the same author in 1899, give fragmentary data on a number of prehistoric sites evidently representing several distinct cultures.

¹¹¹ Sterns, 1915 a; Zimmerman, 1918; Pryor Plank, 1910.

¹¹² Harrington, 1924, pp. 18-19. This "latest culture" suggests the Rulo and Wolf Creek sites assigned to the Kansa by Sterns. A relationship to the Oneota culture of Iowa is also possible, but until careful excavations have been carried on too much speculation is premature.

¹¹³ Moorehead (and Joseph B. Thoburn), 1931, pp. 65-116.

¹¹⁴ Keyes, 1925, 1929. Shetrone, 1931, pp. 330-339, touches on Iowa problems.

similar published data, Dr. Keyes has already defined several important prehistoric cultures.

Of the known prehistoric cultures in this State, the variant of the Hopewell culture found in eastern Iowa finds no direct analogies in Nebraska so far as present indications are concerned. Widespread over the Iowa region, however, is another culture termed the "Algonkian", which, according to Dr. Keyes (1929, p.138), includes perhaps nine-tenths of all prehistoric evidence in the State. This "Algonkian" culture is of the western woodland type and is manifested along the eastern border of the State by effigy mounds and elsewhere by oval and linear and many conical mounds. In addition, there are village sites and rock shelters which contain remains of the same type. In the village sites definite house remains and large refuse heaps seem to be lacking. The pottery of this culture is distinctive. It is rather soft, porous, and unpolished ware, usually brown or red in color, and tempered with coarsely crushed granite. Ornamentation consists of fabric impressions as well as stamped, punched, rouletted, and occasionally incised designs. The vessels have rounded or round-pointed bases and are without definite handles, though small tabs or lugs sometimes occur. Often they are marked by smoothly perforated holes in rims or bodies. The other phases of the artifact complex are not clearly defined as yet, but a strong development of stone work, both chipped and ground, and a correspondingly weak development of bone work has been noted. Of the ground stone artifacts, polished grooved axes are particularly notable, and in the realm of chipped stone a very wide variety of artifact types are present. The name "Algonkian" has been tentatively applied to this culture, owing to its woodland characteristics and its similarity to other complexes in known Algonkian areas to the east.

In northeastern and northwestern Iowa a third prehistoric culture has been designated as the Oneota after the old name for the Iowa River. The Oneota culture is marked by rather large villages in the open, by conical and oblong mounds, deep and large refuse pits and primary burials in mounds and nearby cemeteries. The burials are usually simple, extended, and accompanied by considerable amounts of pottery. The mortuary pottery is small and globular, though larger, cruder cooking pots are found in dwelling sites and refuse heaps. The Oneota ware is shell-tempered and is apparently rather soft in texture with but little polishing.¹¹⁵ In color it is characteristically a slate-black or ashy color, though in many cases burned red. In shape

¹¹⁵ Orr, 1914, pp. 231-239, figures and describes a number of these pots.

it is globular or ovoid with a rounded bottom. Small loop handles for cords, and, on the larger pots, larger handles occur. They are often strengthened and ornamented by a rib on the outside and were often made separately from the pots, being put on after the pot was finished. Decoration is achieved by incised lines running from the bottom of the flaring lip down over the upper part of the body. Punctate incisions, a few simple incised patterns, and occasionally individual cord markings are also employed. For rim decoration finger impressions of the "pie crust" technique are rather characteristic. The decoration on the small mortuary pots is rather regular, whereas that on the larger vessels is very haphazard. Tiny pots of no particular shape and without handles sometimes occur with children's burials. The remaining artifact complex is characterized by catlinite pipes, often of the disk type; by heavy grooved hammers, polished celts (grooved axes are both rare and crude), mullers, metates, sandstone rubbing stones, small triangular arrowpoints, flake scrapers, numerous bone implements, and tubular copper beads. Petroglyphs on nearby cliffs of sandstone and incised pictographs on small polished slabs of catlinite also appear to belong to the Oneota culture. Although the exact historical affiliations of this culture have not yet been determined, it is generally regarded as pertaining to a Siouan people.

A fourth prehistoric culture in northwestern Iowa shows many resemblances to the Oneota, but the pottery of the two is different. The Mill Creek culture, as this fourth type has been designated, occurs in village sites located along the second terraces of the Little Sioux River and two of its tributaries. The villages consist of earth-lodge depressions surrounded by a broad shallow ditch. Refuse deposits are both large and deep. A considerable number of conical mounds occur on neighboring ridges, but whether these pertain to this culture is as yet uncertain. Although the artifact types generally correspond to those of the Oneota culture, the small Mill Creek arrowpoints are more often notched, the stone celt more completely displaces the grooved ax, bone implements are even more abundant, discoidal stones and a few shell and pottery effigies occur. The type of tobacco pipe employed is uncertain, since very few of these have been found. Mill Creek culture ceramics are distinctive and have a hard, fine texture. Finely crushed granite is used for tempering, and the ware is gray or black in color. Globular bowls of small or medium size often show polish on one or both surfaces. The rims are vertical or flaring and are often surmounted with animal-head effigies and handles. Decoration on the rim also takes the form of crosshatching, shallow notching, and the incising of diagonal and horizontal lines on-

the outer surface. The bowls are either plain or encircled by parallel trailed lines. There is as yet no tie-up between the Mill Creek culture and any of the historic tribes, though there are some interesting resemblances to Mandan culture.

Very recently a fifth prehistoric culture in southwestern Iowa has been encountered by Dr. Keyes.¹¹⁶ Artifacts of this type occur along the Missouri River from the southwestern corner of Iowa as far north as the middle of Harrison County. So far no scientific excavations have been made, and the only available material consists of surface collections made by local collectors. The nature of this material, however, leads Dr. Keyes to distinguish the types represented under the designation of the Glenwood culture. In this region both shallow house pits and numerous small ossuary mounds occur, probably as manifestations of the Glenwood culture. Most of the potsherds in these collections are identical with those of the Nebraska culture, and the same may be said for the other artifact types so far reported. However, in these surface collections are a number of sherds clearly marked with cord-wrapped paddles and having definite collars, both of which traits suggest the Upper Republican culture of Nebraska rather than the Nebraska culture proper. The meaning of this association can be determined only by careful excavation work in southwestern Iowa sites. Until this has been accomplished, it will be impossible to decide whether "Upper Republican culture" sites actually do occur as far east as Iowa, whether the sherds represent trade pieces in Glenwood culture sites, or whether independent parallel development of rim types has taken place. It will be remembered that an association of this type occurred in the top level at the Walker Gilmore site, above the Sterns Creek culture; hence similar occurrences in western Iowa seem very important. If the Upper Republican culture is actually represented east of the Missouri River, two explanations are possible, either the Upper Republican culture does not pertain strictly to the prehistoric Caddoan (i. e., Pawnee) culture, or else Caddoan peoples lived to the east of the Missouri as some of their legends have claimed. So far as the main body of material assigned to the Glenwood culture is concerned, it seems probable that the Nebraska and Glenwood cultures will prove to be actually one and the same.

In addition to the close similarity, if not identity, of the Glenwood culture and the Nebraska culture, certain other apparent relationships may be tentatively indicated. Certainly the Sterns Creek culture finds

¹¹⁶ Information from Dr. Keyes at the Plains Archeological Conference, Lincoln, Nebr., September, 1932.

much more congenial company in the "Algonkian" culture of Iowa than it does with any known Nebraska culture. The ceramics of the two are very similar, and the reed-thatched and possibly bark-walled house of the Sterns Creek culture is fundamentally a woodland and not a Plains type of dwelling. Material is not available to institute a detailed comparison in regard to other artifact types. It might be argued that the preponderance of worked bone and antler over flint in the Sterns Creek culture differentiates it from the "Algonkian" horizon in Iowa as summed up by Dr. Keyes. This is true, but it remains to distinguish the specific "Algonkian" culture of western Iowa from the more generalized pattern. When this is done, I strongly suspect that the Sterns Creek culture will find complete parallels on the east side of the Missouri River, whereas these seem to be lacking in eastern Nebraska, where more investigation has already been carried on.

Since the Oneota and Mill Creek cultures center in northern and western Iowa they are in geographical contact with the region of northeastern Nebraska which at present is practically unknown from the archeological standpoint. It is thus impossible to institute valid cultural comparisons between the two regions at the present time. Both the Mill Creek and Oneota cultures, however, seem closer to the Nebraska culture to the south and to the west of the Missouri than they are to the "Algonkian" culture of Iowa. This is shown by the similarity of ceramic forms and decorations and by the general range of artifact types in all three of the former cultures. On the other hand, the Nebraska and Oneota cultures differ in types of villages (Oneota earth lodges have not yet been reported on), method of burial, pottery tempering, and tobacco pipe forms and materials. The Nebraska and Mill Creek cultures likewise differ in these regards, except that grit pot-tempering material is employed by both. The form and decoration of Mill Creek culture ceramics is less like the Nebraska culture, on the other hand, than is the case with Oneota culture ceramics. I am inclined to regard these three prehistoric horizons as generically related and possibly of Siouan origin, but the basis of this grouping is admittedly subjective. Last of all should be mentioned the possibility that the true Oneota culture is represented in the shell-tempered and roughly incised pottery of the Rulo site in extreme southeastern Nebraska and perhaps elsewhere in the eastern part of that State where shell-tempered pottery has been noted. It is apparent that the clear delineation of these horizons should forge strong links between the historic and prehistoric cultures of the eastern woodlands and the central plains. Such research is certain to

cast a flood of light upon even more remote regions in regard to major movements in prehistoric North America.

The work of McKern and others in Wisconsin carries certain of the suggested correlations even farther afield.¹¹⁷ Two culture types in Wisconsin, extending from the prehistoric into the historic period, seem to be related to prehistoric horizons in Iowa and probably in Nebraska. Of these, the Upper Mississippi culture of Wisconsin finds many apparently basic similarities in the Oneota (and Mill Creek?) cultures of Iowa and to a lesser extent in the Nebraska culture just west of the Missouri River. As in Iowa, and probably in Nebraska, this general type of culture in Wisconsin seems to be correlated with the Siouan occupation. Apparently earlier than the Upper Mississippi culture in Wisconsin, yet persisting alongside of it into historic times, is the horizon recently designated as the Lake Michigan culture. This culture is apparently correlated with historic (and prehistoric) peoples of the Algonkian linguistic stock and is related to the widespread Algonkian culture in Iowa and, presumably, to the Sterns Creek culture in eastern Nebraska. It is undoubtedly significant that wherever stratification occurs in Wisconsin the Upper Mississippi culture is later than the Lake Michigan culture, and similarly in eastern Nebraska, at the stratified Walker Gilmore site, the Nebraska culture is demonstrably later than the Sterns Creek culture.

Until one has actually seen the tremendous number of large aboriginal sites that remain to be excavated and reported on in North and South Dakota, the futility of attempting any determination of culture sequences or correlations between this region and other areas at the present time cannot be realized. Although a small amount of scientific excavation has been accomplished and some extremely valuable data have been obtained by the North Dakota Historical Society, the South Dakota Historical Society, the University of South Dakota, and the Logan Museum of Beloit College, much of which awaits publication, archeological research in this region is still in its infancy. This has been pointed out by Robinson, De Land, Grinnell, Montgomery, Will, Spinden, Stirling, and others, yet to the present time the fact does not seem to have penetrated the general archeological consciousness that here is one of the four major archeological areas north of Mexico which is still practically unknown. In the writer's opinion the Upper Missouri area is exceeded in the size and number of sites as well as in cultural importance only by the pueblo region of the south-

¹¹⁷ McKern, 1931. Also verbal report by the same authority at the Vermillion Conference of Plains Archeologists, Vermillion, S. Dak., 1931.

west, the lower Mississippi area, and the mound region centering in Ohio. Not only would the upper Missouri River historic, protohistoric, and prehistoric sites, if properly and systematically worked, yield almost complete data on the early culture and history of some six or seven important North American tribes (see George F. Will, 1924, p. 301), but such work would cast a flood of light on many obscure problems in regions well to the south and east. Yet this highly important archeological area is at present represented by a single major monograph and that only partially based on actual excavation.¹¹⁸

It is therefore impossible to establish anything but the most superficial correlations between this and adjacent areas in the present state of our knowledge. On the other hand, there is every reason to believe that such important problems as the extent and age of the Caddoan movement to the north, the various Siouan movements to the north and west, and the manner in which Algonkian tribes like the Arapaho and Cheyenne shifted from a horticultural woodland to a hunting plains culture, etc., may only be answered when the prehistory of the upper Missouri region is known. All that can be mentioned at the present time are a few highlights on the area which seem to offer extremely promising leads for future research.¹¹⁹

Numerous small conical mounds occur in eastern South Dakota and extend into North Dakota, where effigy mounds are also abundant. Very few of these mounds have been found west of the Missouri, though they extend north a considerable distance into Manitoba and Saskatchewan. (Montgomery, 1908.) In many cases these mounds are marked by burned clay at the base and contain disarticulated human remains. In this burial complex and to a certain extent in the somewhat scarce pottery and the other artifact types which they contain, these mounds rather suggest the Nebraska culture. Along the Missouri River and its tributaries in South Dakota are some 100 or more large village sites and a great number of such villages are also to be found in North Dakota. Particularly interesting are the elaborate fortifications which mark many of these clearly delineated historic and prehistoric villages.¹²⁰ In general, the southern villages are regarded as Arikara and the northern villages as Mandan in origin, although

¹¹⁸ Will, G. F., and Spinden, H. J., *The Mandans, a study of their culture, archaeology and language*, 1906. Reference should also be made to the excellent survey report of G. F. Will, 1924.

¹¹⁹ The following comments are for the most part based on the verbal reports of W. H. Over, George F. Will, and Dana Wright at the Vermillion Conference, August 31—September 1, 1931.

¹²⁰ Will, 1924, shows maps of several of these.

there are also Cheyenne (George Bird Grinnell, 1918) and Hidatsa villages, as well as many which may prove to be of different cultures. (Since the above was written careful and extensive excavations have been carried on at the historic Arikara village across from Mobridge, S. Dak., which was visited by Lewis and Clark, Brackenridge, Bradbury, Maxmillian of Wied, and others. The writer mapped the village, which was burned during Leavenworth's attack in 1823, and excavated both ceremonial and ordinary earth lodges and refuse pits. (Strong, 1933 c.) Stirling and Over excavated numerous burials here at an earlier date. A report on this work by Stirling and Strong is in preparation.)

On the brief reconnaissance trip through the Dakotas in September 1931 the writer was struck by the general resemblance between Upper Republican ceramics (especially the Sweetwater type) and those from one historic and several presumably prehistoric Arikara villages in South Dakota. (Strong, 1932.) The time available was too short and the collections examined too limited to permit any definite conclusions, but I believe that future determination of the actual prehistoric Arikara culture in South Dakota will reveal a horizon closely similar to the Upper Republican culture in Nebraska. The supposition that an early culture of the latter type occurs in South Dakota is strengthened by the work of Mr. Over in a stratified cave site near the headwaters of the Grand River in Hardin County, near the northwestern corner of the state.¹²¹ In this Ludlow cave Mr. Over found surface remains associated with glass beads which appeared to be late Siouan (i. e., Dakota) in origin, while 2½ feet below was another culture stratum containing pottery, fine chipped stone, and bone and shell artifacts. The culture of this lower stratum, as represented in the University Museum at Vermillion, S. Dak., seemed to the writer to be very similar in types of pottery, chipped points, and bone and shell work to the Upper Republican culture of Nebraska. The full significance of this important stratified site can be determined only after the facts have been published in full.

At present certain main lines of archeological inquiry seem promising. Complete excavations should be made in early historic Mandan sites in the north and in early historic Arikara sites to the south to distinguish these two cultures as they existed prior to their virtual amalgamation in later historic times. For serious comparative purposes enough house sites, burials or ossuaries, refuse heaps, and earthworks should be carefully uncovered at each site to clearly reveal a

¹²¹ This cave and the unusual petroglyphs and bas-relief carvings which mark it is described, and some of the latter figured, by Will, 1909, pp. 261-265.

fair sample, not only of the artifact complex but of all other structural features as well. Otherwise, partial comparisons based on selected lines of evidence can hardly be expected to solve the obviously difficult and involved problem presented. If the historic, protohistoric, and prehistoric phases of these two main cultures can be disentangled, a large proportion of the known village sites on the upper Missouri should be accounted for. In the same way the known Cheyenne and Hidatsa sites should be investigated to determine whether these represent distinct cultural types or are mainly imitations of the apparently dominant Arikara and Mandan cultures. Finally, it may be possible to determine the degree of domination exerted respectively by the ancestral Arikara and Mandan peoples, the relative antiquity of each of these groups in the area, the direction from which each people came, and the cultural associations which each brought with them. The peculiar florescence of native culture on the upper Missouri seems at present best accounted for by the contact between these two groups representing a relatively highly advanced Siouan people from the north and east and a similarly advanced Caddoan people from the south and east.

Little is on record concerning the high plains and Rocky Mountain foothill regions to the west of Nebraska. For eastern Wyoming the survey trips of Harlan I. Smith in 1907 and 1908 and that of E. B. Renaud in 1931 furnish nearly all the available data.¹²² Both report numerous quarry sites, of which the very extensive "Spanish Diggings" are the best known. The latter were made to obtain quartzite, and Renaud also found quarries from which speckled or peppered jasper was obtained. Smith noted numerous boulder lodge circles, one stone "fort," and a number of promising caves with entrances closed up by poles. Renaud reports over 200 aboriginal sites, and it appears that there are abundant evidences of human occupation in this portion of the State. Both found small amounts of pottery, Smith finding pottery at only one site (near Rawhide Buttes) but hearing of its occurrence at eight other places. He also reports the presence of metates and mullers in the southern part of the State and mentions steatite pots of egg-shaped or truncated pyramid form. The occurrence of steatite artifacts in southwestern Nebraska has already been noted. From Smith's account petroglyphs occur in both the eastern and western portion of Wyoming but Renaud found comparatively few in the eastern portion covered by his survey. Both report colored pictographs. From these reports it appears that although no striking

¹²² Harlan I. Smith, 1910; Renaud, 1932 b.

cultures are superficially apparent in Wyoming, it is a marginal area of considerable importance.

Eastern Colorado is likewise known only from surface surveys.¹²³ From these it is apparent that there are numerous aboriginal sites in the region. Pottery is recorded from a number of sites but appears to be neither abundant nor highly specialized. It seems to be predominately grit-tempered, and both plain and cord-marked ware was found. A few sherds show incisions. Straight or flaring rims are reported, but collared rims seem to be rare. One sherd indicating a pointed bottom is mentioned. Renaud is inclined to regard the pottery of this region as a western extension of "typical" Plains pottery and notes that it becomes more complex in type on the South Platte as one approaches Nebraska. On the basis of the available data, however, it is not possible to correlate definitely any of the Colorado sherds with Nebraska culture types, except that certain sherds suggestive of the thick ware on the Dismal River seem to be present. The occurrence of obsidian on many sites in eastern Colorado corresponds to its presence at Signal Butte and elsewhere in western Nebraska. Likewise, the absence of catlinite from prehistoric sites in Colorado is in agreement with the late occurrence of this material in Nebraska cultures. Possibly at the other end of the time scale is the occurrence in Yuma County of chipped points closely resembling those reported in association with extinct bison in Nebraska and elsewhere. These include Folsom, Yuma, and Signal Butte I types. Although found on the surface of the ground in "blowouts", the Yuma County points in some cases were at least superficially associated with the remains of extinct animals. (Cook, 1931.) Considering the number of reported associations of this sort in the high plains region, it is probable that actual excavation in Colorado and Wyoming will reveal deposits or habitation sites where such artifacts occur. (Since the above was written the Folsom culture has been found *in situ* in northeastern Colorado; see Roberts, 1935.)

It is obviously impossible to institute any specific cultural comparisons between these regions and western Nebraska at the present time. Such comparisons must come later when more is known about western Nebraska and when enough historic and prehistoric sites have been actually excavated in eastern Colorado and Wyoming to permit the establishment of at least tentative culture groupings for those regions. However, one interesting feature does appear in comparing the known archeology of Nebraska as a whole with the regions immediately to the west. This is the fact that the western border areas alone cor-

¹²³ E. B. Renaud, 1931 a, 1932 a, 1933.

respond to the general Plains archeological area as postulated by Wissler,¹²⁴ whereas central and eastern Nebraska must either fall into his Missouri Valley area or else form a new prehistoric type. This much is already certain, that the western high plains and mountain border areas reveal abundant evidence of purely nomadic hunting cultures, whereas the river and stream valleys of the central loess plains abound in sites marked by earth lodges and numerous ceramic remains. Such a condition of affairs suggests that, at least in later prehistoric times, the strictly hunting peoples were mainly on the margins of the plains, whereas the sedentary type of culture had a much greater extension to the west along the numerous tributaries of the Missouri River.

CONCLUSION

The present venture into the archeology of one State in the central plains area reveals two outstanding features: first, the small amount of scientific archeological work yet accomplished in the central part of the United States, and second, the surprising amount of work there is to be done as well as the breadth and depth of the prehistoric scene that is opening up. Dimly seen at the bottom of the time scale are evidences of early hunters, in some cases associated with extinct animals, presumably in early Recent or late Pleistocene times. Thus the hypothesis of early man in the Plains region is being verified, though the earliest evidence is still somewhat obscure both as to the exact time and the type of the cultures involved. Somewhat later, in western Nebraska, a related hunting culture is more clearly revealed in the lowest stratum at Signal Butte. As was expected, the dawn of the prehistoric period so far as our present knowledge extends finds man intimately related to the great bison herds of the region. On hypothetical grounds it was the presence of such herds from Pleistocene times on that favored the Great Plains as a place to find traces of very early New World hunters. It is this long-awaited evidence that is now coming to light.

The next type of evidence revealed by archeology has not been predicted by theorists. This is the early appearance of semi-horticultural peoples in the region of the central Plains. Strange to say, it is a

¹²⁴ Clark Wissler, 1922, pp. 271-272. Characterized as a barren area influenced on all sides by adjacent cultures. Although pointing out that actual field exploration may change this picture, Wissler states that tipi rings, quarry sites, scattered stone alignments, pictographs, and simple bone and stone artifacts seem to typify the whole area, but that permanent habitation sites and pottery are generally lacking.

woodland culture of northeastern affiliations that occurs on the eastern border as the earliest known occupation of this sort in Nebraska. This was demonstrated by Sterns' discoveries at the Walker Gilmore site, and the fact that the Sterns Creek culture is apparently related to the "Algonkian" and Lake Michigan cultures of Iowa and Wisconsin is undoubtedly significant. It is too early to tell how strong the correlations between these prehistoric cultures and those of the historic Algonkian tribes may be, but they are at least suggested. All that can be said at present is that a culture, possibly Algonkian, and of northeastern woodland type is the earliest known horizon with pottery and cultivated plants (squash and gourds, but so far as known, no maize) in our region, albeit on the extreme eastern border. What contemporary cultures existed to the west in Nebraska at this time are as yet unknown.

Overlying this horizon in eastern Nebraska is the prehistoric Nebraska culture which extends over the rich glacial area later claimed by Ponca, Omaha, Oto, and Kansa. Since the historic archeology of these Siouan tribes is unknown, it is at present impossible to correlate them with any of the prehistoric cultures. Nevertheless, since the Nebraska culture is markedly different from that of the Pawnee in any known period and also affiliates most closely with what are believed to be Siouan cultures in Iowa and Wisconsin, there is reason to suspect that the Nebraska culture will prove to be Siouan in origin. Considering the probable northwestward migration of such Siouan tribes as the Dakota, Hidatsa, and Crow, it is possible that the Nebraska culture represents their movement northward along the Missouri River. From the time of Catlin it has often been stated that the prehistoric earth lodges along this river in Iowa and Nebraska marked the northern migration route of the Mandan but there is actually very little specific resemblance between the Nebraska culture remains and those of the Mandan, at least so far as the latter have been reported on. The most promising prehistoric link with the Mandan at present would seem to be the Mill Creek culture of Iowa, but this lead awaits investigation both in Iowa and in the Dakotas. Since even less is known at present concerning the early historic or prehistoric culture of the Dakota, Hidatsa, or Crow, it may seem even less justifiable to attempt to link the Nebraska culture to an utterly unknown quantity. Nevertheless, since the Dhegiha and Chivere Siouan tribes appear to have peacefully occupied the eastern border of Nebraska within early historic times, it seems logical to suppose that their immediate predecessors in the region were other related peoples who had pressed on to the north. That the

Nebraska culture represents a semisedentary and fairly well advanced mode of life is no argument against this possibility when the rapid change in Plains culture after the acquisition of the horse is fully realized.

It is the firm belief of the author that the possibilities of historic archeology in North America are not fully realized by the majority of anthropologists at the present time. Wherever the approach has been from the known historic into the unknown prehistoric, the results have more than justified the method, as the present superior status of archeology in the Iroquoian and Pueblo areas amply demonstrates. It seems surprising, therefore, that even today there are archeologists more interested in segregating obscure early cultures of unknown periods and affiliations than they are in determining the historic cultures and sequences represented in the regions to be worked. Obviously, in such work the historic cultures need not be an end in themselves, but they do seem to represent the threads that give most promise of untangling the complex skein of prehistory. The prehistoric past comes remarkably close to the historic present in the New World, and it is this fact that especially favors the ethnological and historical approach to archeology on both continents.

Returning to the Nebraska region, it appears that the central and even the extreme western part of the State were occupied by slightly differentiated groups, here designated as the Upper Republican culture, more or less contemporaneously with the Nebraska culture occupation in the east. From its apparent relationship to the protohistoric and historic Pawnee it has been suggested that the Upper Republican culture was ancestral to the Pawnee and probably to the Arikara as well. It is still too early to tell how strong the proposed correlations between the Sterns Creek, Nebraska, and Upper Republican cultures respectively, and the historic tribes of the Algonkian, Siouan, and Caddoan linguistic stocks may be, but the latter of these at least is very strongly suggested by the evidence at hand. Both the Nebraska and Upper Republican cultures were semihorticultural and in general exhibit attenuated characteristics of the southeastern woodland culture area. This connection with the southeast is suggested by the presence in both areas of both square and round earth lodges, the general type of ceramics employed, the occurrence of certain types of artifacts and symbolic designs, and the use of ossuaries in disposing of the dead. Unfortunately, too little is yet on record concerning the regions immediately to the south of Nebraska to permit any definite correlation with known southeastern

cultures. From the standpoint of our immediate area this occurrence of a period of as yet undetermined duration in which horticulture was at least as important as hunting is surprising. Instead of being confined to a narrow strip along the Missouri River in late prehistoric or early historic times, it now appears that this type of life flourished for a considerable period in strictly pre-Columbian times over an area extending some 400 miles west of the Missouri in Nebraska and 200 miles west of that river in South Dakota. At least, evidences of this cultural type have been found as far west as Scottsbluff in the first State and the Ludlow cave in the second. Finally, from the distribution of sites pertaining to the Nebraska and Upper Republican cultures along the waterways of the region, it would seem that the southeastern culture influences had followed up the rivers and streams into the north-central plains. The lack of any southwestern or early Pueblo influences, on the other hand, is marked, and it appears that prior to the acquisition of the horse the barren high plains to the west and staked plains to the south formed definite barriers between these regions.

The protohistoric period in the central plains, if one may judge from the Pawnee, who are the only group so far reported on in this regard, saw a blossoming out of this earlier culture. It is at this time that the largest villages were built and the most highly developed material culture was attained. Lured on by fabulous tales of golden cities, the Spaniards may have looked with disdain upon the towns of Quivira and the warriors of Harahey, but they evidently met a people considerably more advanced in cultural status than were the Wichita and Pawnee tribes a few generations later. The causes leading to the florescence of Pawnee culture in protohistoric times may become clear only when more work has been done in the region, but it can hardly be doubted that the downfall of the culture began when the horse was introduced into the Plains. Few facts are more striking in Pawnee archeology than the inverse ratio that exists between the abundance of horse remains and the degree of excellence as well as abundance of pottery and other artifacts in such sites. This is easily seen by comparing the ceramics from the Burkett and Schuyler sites (pls. 2 and 3), where no horse remains have been reported and those from the Hill site (pl. 1, fig. 1) where horse bones and riding gear were abundant. To some tribes the coming of the horse may have brought cultural advancement but it can hardly be doubted that to the Pawnee it brought definite retrogression.

Thus the historic period, again to judge from the Pawnee record, saw a falling away from old standards and pursuits. The horticultural,

or at least the semihorticultural, mode of life was apparently overshadowed by the seasonal buffalo hunts, until in the late period of which Dunbar writes their permanent villages were occupied only long enough to plant and again to harvest the crops. With the advent of the horse there seems to have come an influx of border peoples from the north, east, and west. With such groups ranging over the plains, outlying, unprotected villages, so common in the prehistoric period, were no longer practical, and the Pawnee appear to have concentrated in large sod-walled villages in the central part of their territories or else traveled en masse following the buffalo.

If the present very incomplete archeological record is to be trusted, the horse culture spread as a thin and strikingly uniform veneer over the central plains, bringing with it many traits more typical of the forest-hunting regions to the north than they were to the prehistoric plains themselves. Given the horse, the plains with their vast bison herds could not be resisted, and in the course of a century or two a new mode of life developed involving many peoples that were apparently relative strangers to the region. Added to the lure of horses and bison hunting was the gradually increasing pressure of an alien culture in the east; thus, while the bison herds drew newly mounted tribes to the west, the guns of the traders in the hands of enemy tribes to the north and east discouraged loitering. Only the fortified villages along the main rivers could withstand the pressure of this influx of hunters and warriors; hence when the French and American explorers entered the region, the warlike nomadic tribes were completely in the ascendancy, and the more advanced semihorticultural villagers had already been crowded back into a narrow strip along the Missouri.

If the situation definitely revealed in eastern and central Nebraska, namely, the pre-Caucasian dominance of a more or less settled horticultural life, can be applied to the rest of the north-central plains it is obvious that the historic period saw a complete reversal of cultural values in the area.¹²⁵ Prior to the coming of the horse it was the village tribes that prevailed in the area; afterward the border tribes or late invaders held the balance of power. Thoroughly motile, possessed of an apparently unlimited meat supply, having nothing to lose by war and almost everything to gain, such peoples as the Comanche, Crow, Gros Ventre, Blackfoot, Kiowa, Assiniboin, and Teton Dakota completely dominated the scene. The others, such as the Mandan, Arikara, Pawnee, Ponca, Omaha, and Oto, clung to

¹²⁵ This state of affairs has recently been pointed out by Kroeber, 1928, p. 395, in a brief analysis of Plains culture which foreshadows the actual archeological findings in a remarkable manner. Also see Swanton, 1930.

what they could of the old settled and horticultural life, or else, like the Arapaho and Cheyenne, gave up the attempt and took over the entire horse complex with its consequent nomadism and parasitism based on the buffalo herds. In Nebraska, to judge from the archeological and historical records, such tribes as the Pawnee later attempted to compromise between the two types of life and apparently failed at both. It can be said, therefore, that although the Dakota mode of life typifies the Nebraska area subsequent to 1650, the old Pawnee type was certainly predominant prior to that time. The same can undoubtedly be said in regard to the Arikara and Mandan on the Upper Missouri, and this probably applies to all the central and eastern plains area.

Taking the bare outlines of Nebraska prehistory as a tentative cross-section of the Plains area generally, it appears that pure hunting cultures dominated the region during two main periods. The first began with the men who hunted the ancient bison and the mammoth and extended for an indefinite period beyond; the second began with the introduction of the horse and ended with the disappearance of the modern bison. Between these two periods, which mark the beginning and the end of Plains Indian history, it now appears that there was a third period of considerable but as yet undetermined duration, when horticulture played at least an equal part with hunting in the economic life of the central plains. It is this horticultural stage in the development of Plains culture which has either been overlooked or disregarded in the majority of ethnological theories bearing on the region.

The fact that the Plains area generally has produced or supported a considerable variety and succession of culture types indicates that its environmental limitations are not so drastic as have often been believed. Not only hunters but primitive agriculturists as well have flourished in the region, and these cultures, while relatively simple, do not exhibit that striking uniformity which characterized the mounted tribes of the region in the eighteenth and nineteenth centuries. Moreover, it is already apparent from the definite correspondences between tribal cultures and geographic areas in Nebraska during the early historic period that even this one State contains several distinct topographic regions quite capable of shaping human culture. Hence one must conclude that the much stressed uniformity of Plains culture in its closing phase was in the main the result of historic forces rather than the direct result of environmental factors. The environment, it is true, furnished a steppe or open country and the great buffalo herds, but historic accident alone accounts for

the white invasion, the introduction of the horse, and the use of fire-arms. These two major forces combined, produced the equestrian and warlike tribes which for a time dominated the region. Then with the disappearance of the buffalo and the spread of Caucasian settlement all types of aboriginal culture vanished from the Plains. Archeological research has already indicated that this familiar historic phase was only the last of a surprisingly ancient and complex sequence of cultures.

Viewed as a whole, the foregoing facts bearing on the development of human society in the central region of North America demonstrate the basic importance of the prehistoric record in checking or corroborating the work of the ethnologist. Even in its early stages archeological research in Nebraska clearly indicates several far-reaching changes in native economic adaptation within the Plains area. When the ethnological data of historic times are analyzed in the light of this greater perspective they assume more clarity, and underlying reasons for the differential survival of certain groups are indicated. Without depth, the ethnological concept of native culture in this important area appears to have been lop-sided, shifting emphasis from the older, and culturally more significant, horticultural tribes to the nomadic militarists of the later historic period. In final analysis, it seems evident that any anthropological or sociological approach which ignores or underestimates the importance of time perspective is open to the same criticism.

LITERATURE CITED

ALLEN, J. A.

1876. The American bisons, living and extinct. Mem. Geol. Surv. Kentucky, vol. 1, pt. 2.

BANDELIER, ADOLPH F.

1890. Final report of investigations among the Indians of the southwestern United States, carried on mainly in the years from 1880 to 1885. Pap. Archaeol. Inst. Amer., Amer. ser., vol. 3, Cambridge.

1893. The gilded man. New York.

BARBOUR, E. H.

- 1907 a. Evidence of loess man in Nebraska. Nebraska Geol. Surv., vol. 2, no. 6, pp. 331-348.

- 1907 b. Evidence of man in the loess of Nebraska. Science, n.s., vol. 25, no. 629, pp. 110-112.

- 1907 c. Ancient inhabitants of Nebraska. Records of the Past, vol. 6, pt. 2, pp. 40-46.

See also Meserve, F. G., and Barbour, Erwin Hinckley.

BARBOUR, E. H., and SCHULTZ, C. BERTRAND

- 1932 a. The mounted skeleton of *Bison occidentalis*, and associated dart-points. Nebraska State Mus., vol. 1, Bull. 32, pp. 263-270, Oct.

- 1932 b. The Scottsbluff bison quarry and its artifacts. Nebraska State Mus., vol. 1, Bull. 34, pp. 283-286, Dec.

BARBOUR, E. H., and WARD, H. B.

1906. Preliminary report on the primitive man of Nebraska. *Nebraska Geol. Surv.*, vol. 2, no. 5, pp. 319-327.

BELL, EARL H.

1932. New evidence unearthed that man lived in Ice Age America. *Science News Letter*, pp. 118-119, Aug. 20.

BELL, EARL H., and VAN ROYEN, WILLIAM

1934. An evaluation of recent Nebraska finds sometimes attributed to the Pleistocene. *Wisconsin Archeol.*, n.s. vol. 13, no. 3, pp. 49-70.

BENGTSON, B. E.

1933. An ancient village of the Grand Pawnee. *Nebraska Hist. Mag.*, vol. 14, no. 2, pp. 124-129.

BIRKET-SMITH, KAJ.

1929. The Caribou Eskimos. Vols. 1-2. Rep. Fifth Thule Expedition, 1921-24.

BLACKMAN, E. E.

1903. Report of Department of Archeology. Ann. Rep. Nebraska State Board of Agr. for 1902, pp. 294-326.
1905. Report of Department of Archeology for 1903 and 1904. Ann. Rep. Nebraska State Board of Agr. for 1904, pp. 207-229.
1906. Archeological Report for 1905. Ann. Rep. Nebraska State Board of Agr. for 1905, pp. 390-400.
- 1907 a. Report of archeologist. Proc. and Coll. Nebraska State Hist. Soc., vol. 15 (ser. 2, vol. 10), pp. 323-359.
- 1907 b. Nehawka flint quarries. *Records of the Past*, vol. 6, pt. 4, pp. 103-110.
- 1907 c. Prehistoric man in Nebraska. *Records of the Past*, vol. 6, pt. 3, pp. 76-79.
1924. Historical Society radio, with account of exploration of aboriginal remains in Loup Valley. *Nebraska Hist. and Rec. of Pioneer Days*, vol. 7, no. 1, pp. 1-8.
1928. Archaeological work in 1927. *Amer. Anthrop.*, n.s. vol. 30, no. 3, pp. 511-512.
1930. Archaeological work in 1929. *Amer. Anthrop.*, n.s. vol. 32, no. 2, p. 357.

BOULE, MARCELLIN

1922. (Review of H. F. Osborn and A. Smith Woodward.) *L'Anthropologie*, vol. 32, pp. 526-527.
1923. Fossil men, elements of human palaeontology, (transl.), pp. 407-408. Edinburgh and London.
1928. La prétendue industrie humaine, osseuse, du Pliocène du Nebraska. *L'Anthropologie*, vol. 38, pp. 443-444. Paris.

BRADBURY, JOHN

1817. *Travels in the interior of America in the years 1809, 1810, and 1811.* Liverpool and London.

BROWER, J. V.

1898. Quivira. Mem. Explorations in the Basin of the Mississippi, vol. 1. St. Paul, Minn.

1899. Harahey. Mem. Explorations in the Basin of the Mississippi, vol. 2. St. Paul, Minn.

BROWN, GEORGE L.

1892. The history of Butler County. Trans. and Rep. Nebraska State Hist. Soc., vol. 4, pp. 275-305.

BURPEE, L. J. (editor)

1927. Journals and letters of Pierre Gaultier De Varennes De La Vérendrye and his sons. Champlain Soc. Toronto.

BUSHNELL, DAVID I., JR.

1908. Ethnographical material from North America in Swiss collections. Amer. Anthrop., n.s. vol. 10, no. 1, pp. 1-15.

1922. Villages of the Algonquian, Siouan, and Caddoan tribes west of the Mississippi. Bur. Amer. Ethnol. Bull. 77.

1927. Burials of the Algonquian, Siouan, and Caddoan tribes west of the Mississippi. Bur. Amer. Ethnol. Bull. 83.

CLARK, W. *See* LEWIS, M., and CLARK.

CONDRA, E. C.

1906. Geography of Nebraska. Lincoln.

CONDRA, G. E., and KEYSER, ALVIN

1908. Preliminary report on the agricultural geology of Nebraska. Ann. Rep. Nebraska State Board Agr. for 1906-1907, pp. 323-350.

CONNELLEY, WILLIAM ELSEY

1918. Notes on the early Indian occupancy of the Great Plains. Coll. Kansas State Hist. Soc. (1915-1918), vol. 14, pp. 438-470.

COOK, HAROLD J.

1927. New geological and palæontological evidence bearing on the antiquity of mankind in America. Nat. Hist., Journ. Amer. Mus. Nat. Hist., vol. 27, no. 3, pp. 240-247.

1928. Glacial Age man in New Mexico. Sci. Amer., pp. 38-40, July.

1931. More evidence of the "Folsom culture" race. Sci. Amer., pp. 102-103, Feb.

COUES, ELLIOTT

1895. The expeditions of Zebulon Montgomery Pike. 3 vols. New York.

CULIN, STEWART

1907. Games of the North American Indians. Twenty-fourth Ann. Rep. Bur. Amer. Ethnol., pp. 1-809.

DAWSON, ELMER J. *See* SCHENCK, W. EGBERT, and DAWSON.

DELAND, CHARLES

1906. The aborigines of South Dakota. Pt. 1 [the Arikara]. South Dakota Hist. Coll., vol. 3, pp. 271-586.

DIXON, R. B. *See* SWANTON, J. R., and DIXON.

DORSEY, J. O.

1886. Migrations of Siouan tribes. Amer. Nat., vol. 20, no. 3, pp. 211-222.

FENNEMAN, N. M.

1928. Physiographic divisions of the United States. Ann. Assoc. Amer. Geogr., vol. 18, no. 4, pp. 261-353.

FIGGINS, J. D.

1927. The antiquity of man in America. Nat. Hist., Journ. Amer. Mus. Nat. Hist., vol. 27, no. 3, pp. 229-239.

1931. An additional discovery of the association of a "Folsom" artifact and fossil mammoth remains. *Proc. Colorado Mus. Nat. Hist.*, vol. 10, no. 4, pp. 23-24.
1933. A further contribution to the antiquity of man in America. *Proc. Colorado Mus. Nat. Hist.*, vol. 12, no. 2.
- FLETCHER, ALICE, and LA FLESCHÉ, FRANCIS
1911. The Omaha tribe. *Twenty-seventh Ann. Rep. Bur. Amer. Ethnol.*, pp. 15-654.
- FOWKE, GERARD
1922. Archeological investigations. *Bur. Amer. Ethnol. Bull.* 76.
- FREMONT, J. C.
1845. The exploring expedition to the Rocky Mountains in the year 1842. Washington.
- FRENCH, B. F.
1850. An account of the discovery of some new countries and nations in North America, in 1673, by Pere Marquette and Sieur Joliet. *Hist. Coll. of Louisiana*, pt. 2, [vol. 2], ed. 2, pp. 279-297. Philadelphia.
- GIFFORD, E. W., and SCHENCK, W. EGBERT
1926. Archaeology of the southern San Joaquin Valley, California. *Univ. California Publ. Amer. Archaeol. and Ethnol.*, vol. 23, no. 1, pp. 1-122.
- GILDER, ROBERT F.
1907. Archeology of the Ponca Creek district, eastern Nebraska. *Amer. Anthropol.*, n.s. vol. 9, no. 4, pp. 702-719.
- 1907 a. The Nebraska loess man. *Records of the Past*, vol. 6, no. 2, pp. 35-39.
- 1907 b. Nebraska loess. *Amer. Antiqu.*, vol. 29, no. 6, pp. 378-381.
1908. Recent excavations at Long's Hill, Nebraska. *Amer. Anthropol.*, n.s. vol. 10, no. 1, pp. 60-73.
- 1908 a. Oto village site in Nebraska. *Amer. Anthropol.*, n.s. vol. 10, no. 1, pp. 173-174.
1909. Excavation of earth-lodge ruins in Eastern Nebraska. *Amer. Anthropol.*, n.s. vol. 11, no. 1, pp. 56-84.
1911. Discoveries indicating an unexploited culture in eastern Nebraska. *Records of the Past*, vol. 10, pt. 5, pp. 249-259.
- 1911 a. Scientific "inaccuracies" in reports against probability of geological antiquity of remains of Nebraska loess man considered by its discoverer. *Records of the Past*, vol. 10, pt. 3, pp. 157-169.
1913. A prehistoric "Cannibal" house in Nebraska. *Records of the Past*, vol. 12, pt. 3, pp. 107-116.
1914. Prehistoric shell necklace from Nebraska. *Records of the Past*, vol. 13, pt. 2, pp. 63-70.
- [1926.] The Nebraska culture man. Omaha. [An illustrated pamphlet of 32 pp., published by Henry F. Kieser.]
- [No date.] Catalogue of objects used by a prehistoric people in what is now Douglas and Sarpy Counties, Nebraska, secured through exploration work of the Robert F. Gilder archaeological survey of 1907 to 1912. [A small pamphlet of 16 pp., illus., 3 maps. Printed by the courtesy of C. N. Dietz, Pres. Omaha Pub. Libr. Board.]

GREEN, A. L. (MAJ.)

1930. The Otoe Indians. Publ. Nebraska State Hist. Soc., vol. 21, pp. 175-209.

GREGORY, W. K.

1927. Hesperopithecus apparently not an ape nor a man. *Science*, n.s. vol. 66, no. 1720, pp. 579-581.

GREGORY, W. K., and HELLMAN, M.

- 1923 a. Notes on the type of *Hesperopithecus haroldcookii* Osborn. *Amer. Mus. Nov.* no. 53, pp. 1-16.
 1923 b. Further notes on the molars of *Hesperopithecus* and of *Pithecanthropus*. *Bull. Amer. Mus. Nat. Hist.*, vol. 48, art. 13, pp. 509-532.

GRINNELL, GEORGE BIRD

1893. Pawnee hero stories and folktales. New York.
 1918. Early Cheyenne villages. *Amer. Anthrop.*, n.s. vol. 20, no. 4, pp. 359-380.
 1920. Who were the Padouca? *Amer. Anthrop.*, n.s. vol. 22, no. 3, pp. 248-260.

HARRINGTON, M. R.

1920. Certain Caddo sites in Arkansas. *Indian Notes and Monogr.*, Mus. Amer. Indian, Heye Foundation. New York.
 1922. Cherokee and earlier remains on Upper Tennessee River. *Ibid.*
 1924. The Ozark bluff-dwellers. *Amer. Anthrop.*, n.s. vol. 26, no. 1, pp. 1-21.

HAYDEN, F. V.

1868. Notes on Indian history, etc. *Ann. Rep. Smithsonian Inst.* 1867, pp. 411-412.
 1876. *Ann. Rep. U. S. Geol. and Geogr. Surv. of the territories, embracing Colorado and parts of adjacent territories; being a report of progress of the explorations for the year 1874.*

HELLMAN, M. *See* GREGORY, W. K., and HELLMAN.

HENNEPIN, FATHER LOUIS

1903. A new discovery of a vast country in America. 2 vols. Edited by R. G. Thwaites. Chicago.

HODGE, F. W. (editor)

1907. Handbook of American Indians North of Mexico. *Bur. Amer. Ethnol. Bull.* 30, pts. 1-2.

HOLMES, W. H.

1903. Aboriginal pottery of the eastern United States. *Twentieth Ann. Rep. Bur. Amer. Ethnol.*, pp. 1-201.

HOWARD, E. B.

1932. Caves along the slopes of the Guadalupe Mountains. *Bull. Texas Archeol. and Paleontol. Soc.*, vol. 4, pp. 7-19, Sept.

HRDLIČKA, A.

1907. Skeletal remains suggesting or attributed to early man in North America. *Bur. Amer. Ethnol. Bull.* 33.

HYDE, GEORGE E. *See* WILL, GEORGE F., and HYDE.

JONES, ALF. D.

1892. What causes Indian mounds. *Trans. Rep. Nebraska State Hist. Soc.*, vol. 4, pp. 111-112.

KEYES, CHARLES R.

1925. Progress of the archeological survey of Iowa. *Iowa Journ. Hist. Pol.*, vol. 23, no. 3, pp. 339-352.
1929. Some methods and results of the Iowa archeological survey. *Wisconsin Archeol.*, n.s. vol. 8, no. 4, pp. 135-143.

KEYSER, A. *See* CONDRA, G. E., and KEYSER.

KROEBER, A. L.

1925. Handbook of the Indians of California. *Bur. Amer. Ethn. Bull.* 78.
1928. Native culture of the Southwest. *Univ. California Publ. Amer. Archaeol. and Ethnol.*, vol. 23, no. 9, pp. 375-398.

LA FLESCHÉ, FRANCIS. *See* FLETCHER, ALICE, and LA FLESCHÉ.

LEIGHTON, MORRIS M.

1931. The Peorian loess and the classification of the glacial drift sheets of the Mississippi Valley. *Journ. Geol.*, vol. 39, no. 1, pp. 45-53.

LE RAYE, CHARLES

1908. The journal of Charles Le Raye. *South Dakota Hist. Coll.*, vol. 4, pp. 151-180.

LEWIS, M., and CLARK, WM.

1904. Original journals of the Lewis and Clark expedition, 1804-1806, vol. 1. Edited by R. B. Thwaites. New York.

LINTON, RALPH

1924. The origin of the Plains earth lodge. *Amer. Anthropol.*, n.s. vol. 26, no. 2, pp. 247-257.

LONG, STEPHEN H.

1823. An account of an expedition from Pittsburgh to the Rocky Mountains. Vols. 1-2, with atlas. Compiled by Edwin James. Philadelphia.

LUGN, A. L., and SCHULTZ, C. BERTRAND

1934. The geology and mammalian fauna of the Pleistocene of Nebraska. Pt. 1: Outline of Pleistocene geology of Nebraska. Pt. 2: The Pleistocene mammals of Nebraska. *Nebraska State Mus.*, vol. I, Bull. 41, pp. 319-392.

MARGRY, PIERRE

1874. Margry papers. *Memoirs et Documents pour servir a L'Histoire des Origines Françaises des Pays d'Outremer.* 6 vols. Paris.

MCGEE, W. J.

1897. The Siouan Indians. *Fifteenth Ann. Rep. Bur. Amer. Ethnol.*, pp. 153-204.

MCKERN, W. C.

1931. Wisconsin pottery. *Amer. Anthropol.*, n.s. vol. 33, no. 3, pp. 383-389.
1934. Certain culture classification problems in middle western archaeology. Circular series, no. 17, Committee on State Archaeological Surveys, Division of Anthropology and Psychology, National Research Council. August.

MERRILL, MOSES

1892. Extracts from the diary of Rev. Moses Merrill, a missionary to the Otoe Indians from 1832 to 1840. *Trans. and Rep. Nebraska State Hist. Soc.*, vol. 4, pp. 160-191.

MERRILL, SAMUEL PEARCE

1892. Personal sketch of Rev. Moses Merrill. *Ibid.*, pp. 157-159.

MESERVE, F. G. and BARBOUR, ERWIN HINCKLEY

1932. Association of an arrowpoint with *Bison occidentalis*. Nebraska State Mus. vol. 1, Bull. 27, pp. 239-243, February.

MONTGOMERY, HENRY

1908. Prehistoric man in Manitoba and Saskatchewan. Amer. Anthropol., n.s. vol. 10, no. 1, pp. 33-40.

MOONEY, JAMES

1898. Calendar history of the Kiowa Indians. Seventeenth Ann. Rep. Bur. Amer. Ethnol., pp. 129-445.

1907. The Cheyenne Indians. Mem. Amer. Anthropol. Assoc., vol. 1, pt. 6.

MOORE, CLARENCE B.

1905. Certain aboriginal remains of the Black Warrior River. Philadelphia.

1916. Some aboriginal sites on Green River, Kentucky. Philadelphia.

MOOREHEAD, WARREN K.

1928. The Cahokia mounds. Univ. Illinois Bull., vol. 26, no. 4.

1931. Archaeology of the Arkansas River Valley. New Haven.

MORRIS, EARL H.

1927. The beginnings of pottery making in the San Juan area; unfired prototypes and the wares of the earliest ceramic period. Anthropol. Pap. Amer. Mus. Nat. Hist., vol. 28, pt. II, pp. 125-198.

MURIE, JAMES R.

1914. Pawnee Indian societies. Anthropol. Pap. Amer. Mus. Nat. Hist., vol. 11, pt. 7, pp. 543-644.

NELSON, N. C.

1928. Pseudo-artifacts from the Pliocene of Nebraska. Science, n.s. vol. 67, no. 1734, pp. 316-317.

ORR, ELLISON

1914. Indian pottery of the Oneota or upper Iowa River Valley in north-eastern Iowa. Proc. Iowa Acad. Sci., vol. 21, pp. 231-239.

OSBORN, HENRY FAIRFIELD

1907. Discovery of a supposed primitive race of men in Nebraska. Century Mag., n.s. vol. 73, no. 3, pp. 371-375.

1922. Hesperopithecus, the first anthropoid primate found in America. Amer. Mus. Nov., no. 37, pp. 1-5.

- 1922 a. Hesperopithecus, the anthropoid primate of western Nebraska. Nature, vol. 110, no. 2756, pp. 281-283.

1927. Recent discoveries relating to the origin and antiquity of man. Science, n.s. vol. 65, no. 1690, pp. 481-488.

PARKER, ARTHUR C.

1922. The archaeological history of New York, pt. 2. New York State Mus. Bull. nos. 237, 238. Albany.

PIKE-PAWNEE VILLAGE

1927. The war between Nebraska and Kansas. Both sides of the dispute over the true location of the Pike-Pawnee Indian village where the Spanish flag came down and the Stars and Stripes went up. [A collection of papers by various authors.] Nebraska Hist. Mag., vol. 10, no. 3. Lincoln.

PLANK, PRYOR

1910. Old village sites in Doniphan County, Kansas. Archaeol. Bull., vol. 1, no. 4, pp. 97-99.

POPE, SAXTON TEMPLE

1918. Yahi archery. Univ. California Publ. Amer. Archaeol. and Ethnol., vol. 13, no. 3, pp. 103-152.

POYNTER, C. W. M.

1915. A study of Nebraska crania. Amer. Anthrop., n.s. vol. 17, no. 3, pp. 509-524.

PROUDFIT, S. V.

1881. Antiquities of the Missouri bluffs. Amer. Antiq., vol. 3, no. 4, pp. 271-280.

RENAUD, E. B.

- 1931 a. Archæological survey of eastern Colorado. Univ. Denver Dep. Anthrop.
1931 b. Prehistoric flaked points from Colorado and neighboring districts. Proc. Colorado Mus. Nat. Hist., vol. 10, no. 2, pp. 1-21.
1932 a. Archæological survey of eastern Colorado, 2d Rep. Univ. Denver Dep. Anthrop.
1932 b. Archæological survey of eastern Wyoming, summer, 1931. Ibid.
1933. Archæological survey of eastern Colorado. Third Rep. Ibid.
1934 a. Archæological survey of western Nebraska, summer, 1933. Ibid.
1934 b. The first thousand Yuma-Folsom artifacts. Ibid.

ROBERTS, F. H. H., JR.

1935. A Folsom camp site and workshop in northern Colorado Expl. and Field-work Smithsonian Inst. 1934, pp. 61-64.

ROMER, ALFRED S.

1933. Pleistocene vertebrates and their bearing on the problem of human antiquity in North America. In *The American Aborigines*, edited by D. Jenness, pt. II, pp. 49-83, Univ. of Toronto Press.

SCHENCK, W. EGBERT

1926. The Emeryville shellmound. Final Report. Univ. California Publ. Amer. Archaeol. and Ethnol., vol. 23, no. 3, pp. 147-282.

See also GIFFORD, E. W. and SCHENCK.

See also STRONG, W. D., STEWARD, J. H., and SCHENCK.

SCHENCK, W. EGBERT, and DAWSON, ELMER J.

1929. Archaeology of the northern San Joaquin Valley. Univ. California Publ. Amer. Archaeol. and Ethnol., vol. 25, no. 4, pp. 289-413.

SCHULTZ, C. BERTRAND

1932. Association of artifacts and extinct mammals in Nebraska. Nebraska State Mus., vol. I, Bull. 33, pp. 271-282, Nov. 1932.

See also BARBOUR, E. H., and SCHULTZ.

See also LUGN, A. L., and SCHULTZ.

SEARS, PAUL B.

1932. The archaeology of environment in eastern North America. Amer. Anthrop., n.s. vol. 34, no. 4, pp. 610-622.

SETZLER, FRANK M.

1933. Pottery of the Hopewell type from Louisiana. Proc. U. S. Nat. Mus., vol. 82, art. 22, pp. 1-21.

SHAW, E. W. *See* TROWBRIDGE, ARTHUR, and SHAW.

SHEA, J. G.

1852. Discovery and exploration of the Mississippi Valley. New York.
1861. Early voyages up and down the Mississippi. Albany.

SHELFORD, VICTOR E.

1926. Naturalist's guide to the Americas. Baltimore.

SHETRONE, H. C.

1930. The Mound-builders. New York and London.

SHIMEK, B.

1908. Nebraska "Loess man". Bull. Geol. Soc. Amer., vol. 19, pp. 243-254.

1917. The loess and the antiquity of man. Proc. Iowa Acad. Sci., vol. 24, pp. 93-98.

SHINE, FATHER M. A.

1914. The Nebraska aborigines as they appeared in the eighteenth century. Nebraska Acad. Sci. Publ., vol. 9, no. 1, pp. 1-23.

SKINNER, ALANSON

1921. Notes on Iroquois archeology. Indian Notes and Monogr., Mus. Amer. Indian, Heye Foundation. New York.

1926. Ethnology of the Ioway Indians. Bull. Publ. Mus. Milwaukee, vol. 5, no. 4.

SMITH, G. ELLIOT

1924. The evolution of man. Essays. Oxford Univ. Press.

SMITH, HARLAN I.

1910. An unknown field in American archæology. Bull. Amer. Geogr. Soc., vol. 42, no. 7, pp. 511-521.

SMITH, T. BUCKINGHAM

1857. Coleccion de varios documentos para la historia de la Florida y Tierras Adyacentes, tomo 1. London.

SPINDEN, H. J. *See* WILL, G. F., and SPINDEN.

STERNS, FRED H.

1914. Ancient lodge sites on the Missouri in Nebraska. Amer. Anthrop., n.s. vol. 16, no. 1, pp. 135-137.

1915. A stratification of cultures in eastern Nebraska. Amer. Anthrop., n.s. vol. 17, no. 1, pp. 121-127.

1915 a. The archaeology of eastern Nebraska, with special reference to the culture of the rectangular earth lodges. 2 vols. (Unpublished thesis in partial fulfillment of the requirements for the degree of Doctor of Philosophy in Harvard University.)

STEWART, J. H. *See* STRONG, W. D., SCHENCK, W. EGBERT, and STEWART.

STRONG, W. D.

1927. An analysis of Southwestern society. Amer. Anthrop., n.s. vol. 29, no. 1, pp. 1-61.

1929. Aboriginal society in southern California. Univ. California Publ. Amer. Archaeol. and Ethnol., vol. 26.

1932 a. An archeological reconnaissance in the Missouri Valley. Expl. and Field-Work Smithsonian Inst. 1931, pp. 151-158.

1932 b. Recent discoveries of human artifacts associated with extinct animals in Nebraska. Science Service Research Announcement, no. 130, Washington, June 27.

1933. a Signal Butte, a prehistoric narrative in the high plains. Expl. and Field-Work Smithsonian Inst. 1932, pp. 69-72.

1933 b. The Plains culture area in the light of archeology. Amer. Anthrop., n.s. vol. 35, no. 2, pp. 271-287.

1933 c. Studying the Arikara and their neighbors on the upper Missouri. Expl. and Field-Work Smithsonian Inst. 1932, pp. 73-76.

- STRONG, W. D., SCHENCK, W. E., and STEWARD, J. H.
1930. Archaeology of the Dalles-Deschutes region. Univ. California Publ. Amer. Archaeol. and Ethnol., vol. 29, no. 1, pp. 1-154.
- SWANTON, J. R.
1930. Some neglected data bearing on Cheyenne, Chippewa, and Dakota history. Amer. Anthrop., n.s. vol. 32, no. 1, pp. 156-160.
- SWANTON, J. R., and DIXON, R. B.
1914. Primitive American history. Amer. Anthrop., n.s. vol. 16, no. 3, pp. 376-412.
- THOMAS, CYRUS
1894. Report on the mound explorations of the Bureau of Ethnology. Twelfth Ann. Rep. Bur. Amer. Ethnol., pp. 17-730.
- TODD, J. E.
1888. Some ancient diggings in Nebraska. Amer. Antiq., vol. 10, no. 6, pp. 374-376.
- TROWBRIDGE, ARTHUR C., and SHAW, E. W.
1916. Geology and geography of the Galena and Elizabeth quadrangles. Bull. 26, Illinois State Geol. Surv.
- UDDEN, JOHAN AUGUST
1900. An old Indian village. Augustana Libr. Publ., no. 2, Rock Island, Ill.
- VAN ROYEN, WILLIAM. *See* BELL, EARL H., and VAN ROYEN.
- VOSY-BOURBON, H.
1929. Traces de l'homme dans le pliocène du Nebraska. Journ. Soc. Amer. Paris, n.s. vol. 20, p. 408.
- WARD, H. B. *See* BARBOUR, E. H., and WARD.
- WEBB, WILLIAM S.
1928. A prehistoric village site in Greenup County, Kentucky. Amer. Anthrop., n.s. vol. 30, no. 2, pp. 268-281.
- WEDEL, WALDO R.
1933. Preliminary notes on the archaeology of Medicine Valley in southwestern Nebraska. Nebraska Hist. Mag., vol. 14, no. 3, pp. 145-166. (Printed in 1934.)
1934. Reports on Fieldwork by the Archaeological Survey of the Nebraska State Historical Society, May 1-July 23, 1934. *Ibid.*, vol. 15, no. 3.
I. Contributions to the archaeology of the upper Republican Valley, Nebraska.
II. Minneapolis I: A prehistoric village site in Ottawa County, Kansas.
III. Salina I: A protohistoric village site in McPherson County, Kansas.
IV. Appendix: Preliminary classification for Nebraska and Kansas cultures. (Printed in 1935.)
[No date.] An introduction to Pawnee archeology. Mss., Bur. Amer. Ethnol. (Awaiting publication.)
- WILDER, H. H.
1926. The pedigree of the human race. New York.

WILL, GEORGE F.

1909. Some observations made in northwestern South Dakota. *Amer. Anthropol.*, n.s. vol. 11, no. 2, pp. 257-265.
 1924. *Archaeology of the Missouri valley*. *Anthropol. Pap. Amer. Mus. Nat. Hist.*, vol. 22, pt. 6. New York.

WILL, GEORGE F., and HYDE, GEORGE E.

1917. Corn among the Indians of the upper Missouri. *Little Histories of North American Indians*, no. 5. St. Louis.

WILL, GEORGE F., and SPINDEN, H. J.

1906. The Mandans. *Pap. Peabody Mus. Amer. Archaeol. and Ethnol.*, Harvard Univ., vol. 3, no. 4.

WILSON, THOMAS

1899. Arrowpoints, spearheads, and knives of prehistoric times. *Ann. Rep. U. S. Nat. Mus.* 1897, pt. 1, pp. 811-988.

WINSHIP, GEORGE PARKER

1896. The Coronado expedition, 1540-1542. *Fourteenth Ann. Rep. Bur. Amer. Ethnol.*, pp. 339-613.

WINTENBERG, W. J.

1912. "Toggle-Heads" or "shuttles". *Records of the Past*, vol. 11, no. 1, p. 27.

WISSLER, CLARK

1908. Ethnographical problems of the Missouri Saskatchewan area. *Amer. Anthropol.*, n.s. vol. 10, no. 2, pp. 197-207.
 1914. The influence of the horse in the development of Plains culture. *Amer. Anthropol.*, n.s. vol. 16, no. 1, pp. 1-25.
 1920. *North American Indians of the Plains*. *Amer. Mus. Nat. Hist.*, Handbook ser., no. 1. 2nd ed.
 1922. *The American Indian*. 2nd ed. New York.

WOODRUFF, ELMER GRANT

1906. The geology of Cass County, Nebraska. *Nebraska Geol. Surv.*, vol. 11, pt. 2, pp. 176-290.

WOODWARD, A. SMITH

1922. A supposed ancestral man in North America. *Nature*, vol. 109, no. 2745, p. 750.

ZIMMERMAN, M. E.

1918. The ground-house Indians and stone-cist grave builders of Kansas and Nebraska. *Coll. Kansas State Hist. Soc.*, vol. 14, pp. 471-487.

EXPLANATION OF PLATES

PLATE I

Historic Pawnee artifact types

	Page
FIG. 1. Pottery, Hill site (<i>circa</i> 1805).....	58
FIG. 2. Other artifact types, Hill site (<i>circa</i> 1805). <i>a, d</i> , quartzite scrapers; <i>b</i> , bison rib beaming tool; <i>c</i> , bone "paint brush"; <i>e</i> , broken shaft polisher; <i>f</i> , bone fleshing tool.....	60

PLATE 2

Protohistoric Pawnee rim sherds (*circa* 1600)

	Page
FIG. 1. Schuyler site	64
FIG. 2. Burkett site	64

PLATE 3

Restored Protohistoric Pawnee pots, from houses 1 and 2, Burkett site
(*circa* 1600)

65

PLATE 4

Lost Creek site, Upper Republican culture

FIG. 1. Post holes along east wall of rectangular earth lodge (house 1)....	76
FIG. 2. Small cache pit and slab cover (house 1).....	80
FIG. 3. Large cache pit floored with slabs (house 1).....	79

PLATE 5

Rim sherds, Upper Republican culture

FIG. 1. From house 1, Lost Creek.....	82
FIG. 2. From sites on Lost Creek and Rebecca Creek.....	82

PLATE 6

Bone and antler artifacts

FIG. 1. From various sites, Upper Republican culture.....	93-245
FIG. 2. Bison scapula digging tools from various cultures. <i>a</i> , Lost Creek, Upper Republican culture; <i>b</i> , Gates site, Nebraska culture; <i>c</i> , Burkett site, Protohistoric Pawnee; <i>d</i> , Hill site, Historic Pawnee	93-245

PLATE 7

Chipped flint artifacts from various cultures in Nebraska

FIG. 1. Types of points and end scrapers. <i>a</i> , <i>c</i> , <i>d</i> , <i>f</i> , <i>g</i> , <i>j</i> , <i>m</i> , <i>o</i> , Upper Re- publican culture; <i>b</i> , <i>h</i> , <i>k</i> , <i>l</i> , <i>p</i> , <i>r</i> , <i>s</i> , Nebraska culture; <i>e</i> , Cumro site (with fossil bison); <i>n</i> , Weeping Water site; <i>i</i> , <i>q</i> , Protohis- toric Pawnee	93-245
FIG. 2. Types of knives or blades. <i>a</i> , <i>g</i> , <i>i</i> , Nebraska culture; <i>b</i> , <i>c</i> , <i>d</i> , <i>e</i> , <i>h</i> , <i>j</i> , <i>k</i> , <i>m</i> , <i>n</i> , Upper Republican culture; <i>f</i> , Sterns Creek culture; <i>l</i> , Weeping Water site.....	93-245

PLATE 8

Prairie Dog Creek ossuary, Upper Republican culture

FIG. 1. Looking north from site down the creek to the Republican River (village site in cornfield to right).....	103
---	-----

	Page
FIG. 2. Ossuary, with Indian Hill in the background.....	103
FIG. 3. Cross-section of the ossuary with deepest, scattered bones projecting	107
FIG. 4. Male skull in situ.....	107

PLATE 9

Rim sherds, Upper Republican culture, and artifacts of bone,
shell and copper

FIG. 1. Rim sherds, Prairie Dog Creek ossuary.....	108
FIG. 2. Bone, shell and copper artifacts, Upper Republican culture, and (<i>e</i>) toggled harpoon, Nebraska culture (Gilder collection).....	93-245

PLATE 10

Marshall and Prairie Dog Creek ossuaries

FIG. 1. Marshall site, shell bead ossuary on point of the bluff.....	116
FIG. 2. Antler bracelet with incised hand and circle design, Prairie Dog Creek ossuary	111
FIG. 3. Human bones and shell beads mixed at Marshall site.....	118
FIG. 4. Antler bracelet in situ, Prairie Dog Creek ossuary.....	111
FIG. 5. Bottom outline of individual ossuary pit at Marshall site.....	118

PLATE 11

Shell artifacts and types of beads, various cultures in Nebraska

FIG. 1. Shell artifacts. <i>a, d, e, f</i> , Nebraska culture; <i>b, c</i> , Upper Republican culture; <i>g, h, i</i> , Indian Hill, Upper Republican culture (?).....	93-245
FIG. 2. Types of beads from various sites. <i>a</i> , surface of Schuyler site (Protohistoric Pawnee?); <i>b, c, g</i> , Marshall ossuary; <i>d, i, j</i> , house 1, Lost Creek (Upper Republican culture); <i>h</i> , Prairie Dog Creek ossuary (Upper Republican culture).....	93-245

PLATE 12

Nebraska culture house sites

FIG. 1. Excavating south end of house 2, Rock Bluffs.....	126
FIG. 2. House pit 1, Gates site, prior to excavation.....	147
FIG. 3. Excavating house 1, Gates site.....	147

PLATE 13

Large pot, house 2, Rock Bluffs, Nebraska culture

FIG. 1. Pot in cache pit (note white ash).....	132
FIG. 2. Pot restored.....	132

PLATE 14

Nebraska culture pottery

- | | Page |
|--|---------|
| FIG. 1. <i>a, d, e, f</i> , house 2, Rock Bluffs; <i>b, c</i> , house 2, Gates site..... | 124-184 |
| FIG. 2. From various sites in the vicinity of Omaha (Gilder collection) .. | 124-184 |

PLATE 15

Nebraska culture rim sherds

- | | |
|--|---------|
| FIG. 1. <i>a, h</i> , house 2, Rock Bluffs; <i>b, c, c, i</i> , house 1, Gates site; <i>d, f, g</i> , house 2, Gates site..... | 124-184 |
| FIG. 2. <i>a, b, c, f, g</i> , house 2, Gates site; <i>c</i> , house 1, Gates site; <i>d</i> , Childs Point (Gilder collection); <i>h, i</i> , house 2, Rock Bluffs..... | 124-184 |

PLATE 16

Nebraska culture ceramics, and types of tobacco pipes from various cultures

- | | |
|---|---------|
| FIG. 1. Nebraska culture ceramics. <i>a, b</i> , face pipe, house 2, Gates site; <i>c, d, c</i> , and <i>f</i> (impress of coiled basketry) house 2, Rock Bluffs... .. | 124-184 |
| FIG. 2. Types of tobacco pipes from various cultures in Nebraska. Nebraska culture, <i>a, b, d, f, h, j</i> (Gates site), <i>c, o</i> (Rock Bluffs), <i>m</i> (Gilder collection); Upper Republican culture, <i>c, g, k, n, p</i> ; Sterns Creek culture, <i>i</i> ; Historic Pawnee, <i>l</i> (Hill site)..... | 124-184 |

PLATE 17

Ground stone and large chipped artifacts, various cultures in Nebraska

- | | |
|--|--------|
| FIG. 1. Ground stone implements. Nebraska culture, <i>a, c, e, g, h, i, j</i> ; Upper Republican culture, <i>d, f, k</i> ; <i>b</i> , surface find, Cass County..... | 93-245 |
| FIG. 2. Stone axes and celts. Nebraska culture, <i>c, d, e, f, g</i> ; Upper Republican culture, <i>i, j, k, l, m</i> ; Sterns Creek culture, <i>h</i> ; <i>b</i> , surface find, Walker Gilmore site; <i>a</i> , surface find, Cass County..... | 93-245 |

PLATE 18

Bone and antler artifact types, various cultures in Nebraska

- | | |
|--|---------|
| FIG. 1. Mainly Nebraska culture. Nebraska culture, <i>a, b, c, m</i> (Gates site), <i>f, g, l, n</i> (Rock Bluffs site), <i>c, h, i, j, k, o, p, q, r, s</i> (Childs Point, Gilder collection); Upper Republican culture, <i>d</i> (house 1, Lost Creek) | 93-245 |
| FIG. 2. Sterns Creek culture implements. <i>o</i> , cut wood; <i>c</i> , chipped stone pick; remainder of bone or antler (Walker Gilmore site, level I).... | 187-195 |

PLATE 19

Sterns Creek culture, Walker Gilmore site

	Page
FIG. 1. <i>a</i> , complete pot; <i>b</i> , restored pot, Sterns Creek culture.....	187
FIG. 2. Exposure of Sterns Creek culture strata in bank opposite waist of human figure	175
FIG. 3. Similar deep exposure of white ash in hearth (between the two figures)	175
FIG. 4. Fragments of Sterns Creek culture pottery near surface at <i>A</i> (see map, fig. 24).....	196

PLATE 20

Mound and quarry trench, Cass County

FIG. 1. "Mound" 1 above Walker Gilmore site.....	182
FIG. 2. Excavating "mound" 1, above Walker Gilmore site.....	182
FIG. 3. Old quarry trench A, Weeping Water site.....	203

PLATE 21

Upper Republican culture artifacts from various sites

FIG. 1. <i>a</i> , pot found south of Republican River near Franklin; <i>b</i> , pot from house 2, Lost Creek; <i>c</i> , <i>d</i> , pipe and bison ulnae tools from house 2, Lost Creek (photographs courtesy of J. P. Spence).....	101
FIG. 2. Rim sherds from Medicine Creek sites <i>a-d</i> , and from Sweet-water site <i>e-m</i>	240-242

PLATE 22

Dismal River potsherds; and fossilized, burned bone with artifacts from Sarpy County

FIG. 1. Potsherds from surface of three sites on the Dismal River, <i>a</i> , <i>b</i> , <i>c</i> , <i>e</i> , thick, hole-tempered ware; <i>d</i> , <i>f-m</i> , thin, smooth ware; <i>n</i> (?)....	215
FIG. 2. <i>a</i> , excavating in gravel bed containing burned fossil bone and flint artifacts, Bird Creek, Sarpy County; <i>b-f</i> , <i>i</i> , <i>j</i> , <i>k</i> , artifacts and flint fragments; <i>g</i> , <i>h</i> , <i>l-q</i> , fossil bone fragments.....	217

PLATE 23

Stratified site on the summit of Signal Butte, Scotts Bluff County

FIG. 1. Signal Butte from the east, showing break with main escarpment of the Wildcat Hills.....	224
FIG. 2. Cross-section exposure near center of butte (west face of row 1) showing three levels of occupation (I-III), underlying sands, and basic cap rock (compare with fig. 29).....	227
FIG. 3. Exposure on south edge of butte (north face of section E, east face of row 5) showing thick, black nature of level I. (Level III overlies level II so closely at this point that they are difficult to distinguish.)	228

PLATE 24

Artifact types from top level (III) and middle level (II), Signal Butte

	Page
FIG. 1. Artifact types from top level (III), Signal Butte.....	229-236
FIG. 2. Pottery from top level (III). <i>a</i> , Upper Republican type; <i>b</i> , Dismal River (smooth) type; and artifact types from middle level (II) (<i>c-q</i>)	229-236

PLATE 25

Artifact types from lowest level (I), Signal Butte

FIG. 1. Chipped stone implement types.....	229-236
FIG. 2. Bone, antler and ground stone implement types. (The types of artifacts from Signal Butte are illustrated in rough proportion to their relative abundance in each level.).....	229-236



1. Ceramics.

(Rule=6 inches. For explanation, see p. 310.)

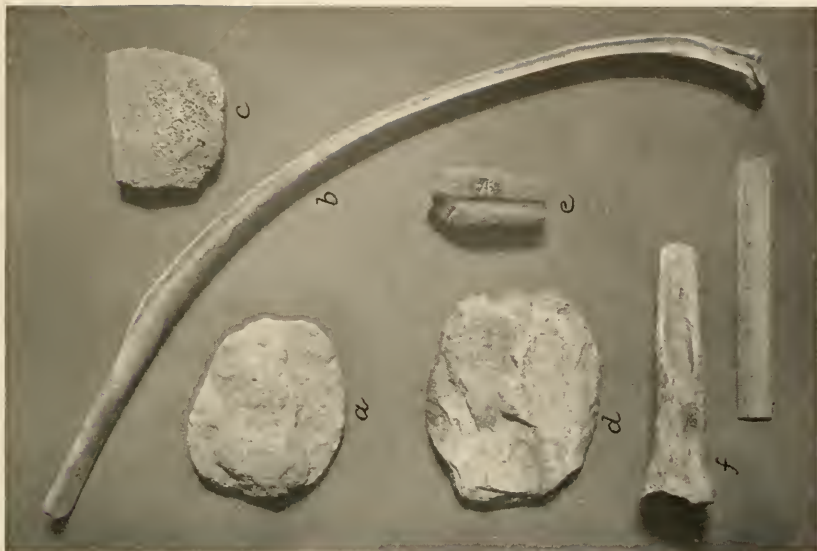

2. Other implements.

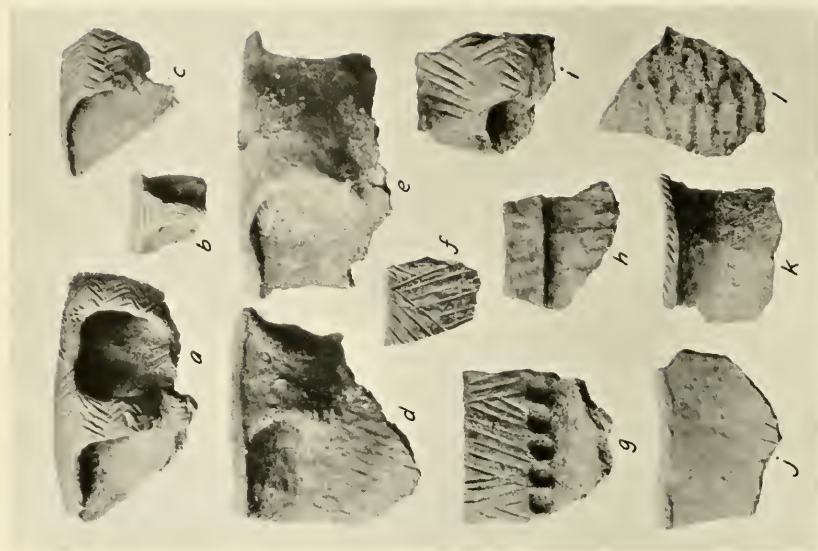
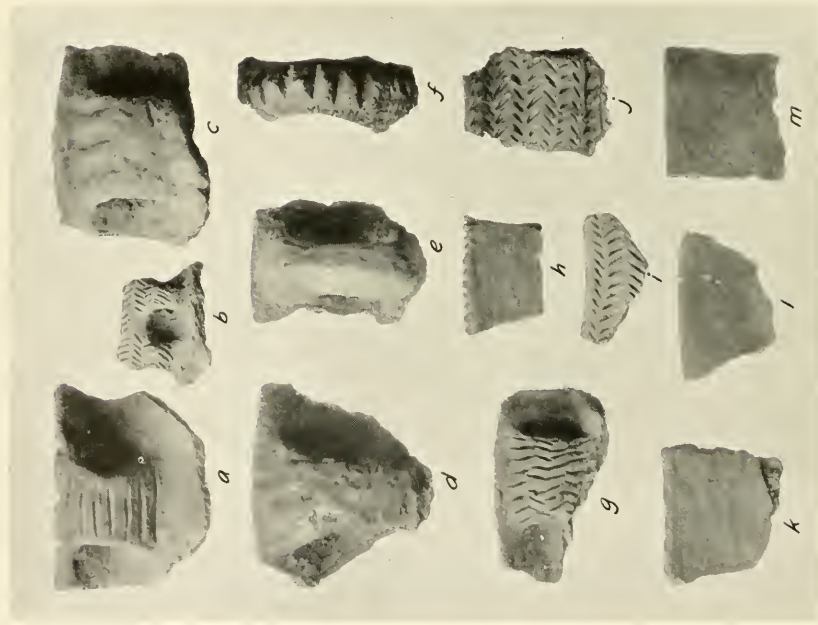

Photograph courtesy of Dr. E. H. Bell.

PROTOHISTORIC PAWNEE RIM SHERDS (CIRCA 1600)

1. Schnyler site.

2. Barkett site.

(C. is about 1/2; 2. is about 3/4. For explanation, see p. 311.)



RESTORED PROTOHISTORIC PAWNEE POTS, BURKETT SITE
(CIRCA 1600)

(Not to scale. Height of *a* 7½, *b* 16¾, *c* 11½ inches. For explanation,
see p. 311.)



LOST CREEK SITE. UPPER REPUBLICAN CULTURE
(For explanation, see p. 311.)



RIM SHERDS, UPPER REPUBLICAN CULTURE

1. House 1, Lost Creek.

2. Lost Creek and vicinity.

(For explanation, see p. 311.)

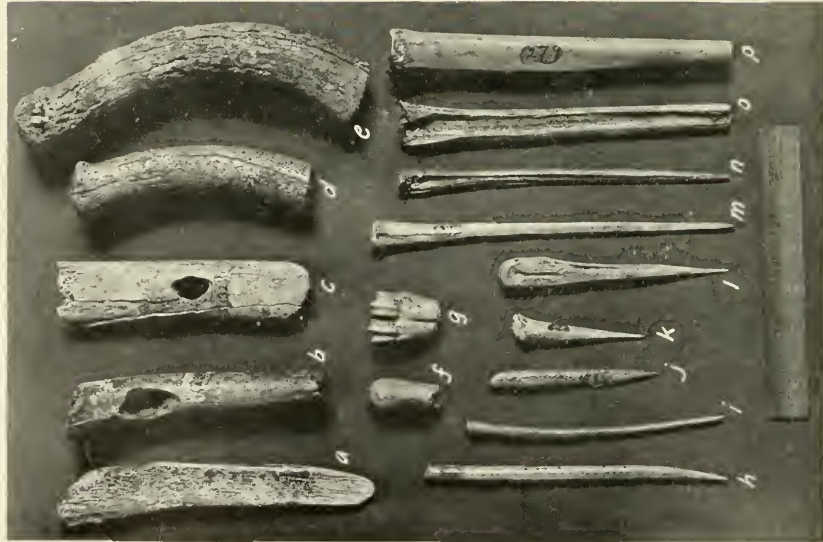

1. Upper Republican culture.

(Rule=6 inches. For explanation, see p. 311.)



BONE AND ANTLER ARTIFACTS

2. Various cultures in Nebraska.



CHIPPED FLINT ARTIFACTS FROM VARIOUS CULTURES IN NEBRASKA

1. Types of points and end scrapers.
(Rule=6 inches. For explanation, see p. 311.)
2. Types of knives or blades.



PRAIRIE DOG CREEK OSSUARY, UPPER REPUBLICAN CULTURE
(For explanation, see p. 311.)



RIM SHERDS, UPPER REPUBLICAN CULTURE, AND ARTIFACTS OF BONE, SHELL AND COPPER

- 1. Rim sherds, Prairie Dog Creek ossuary.
- 2. Upper Republican culture artifact types, except (c) Nebraska culture.

(Rule=6 inches. For explanation, see p. 312.)

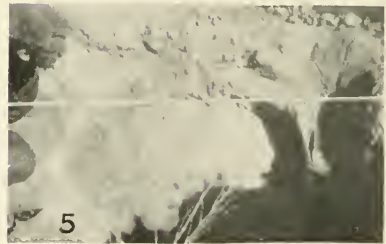
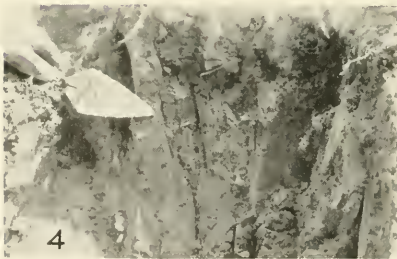
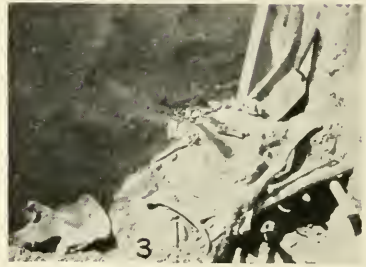

MARSHALL AND PRAIRIE DOG CREEK OSSUARIES

- 1. Marshall site, on point.
- 2. Antler bracelet, Prairie Dog Creek.
- 3. Ossuary pit, Marshall site.
- 4. Antler bracelet in situ.
- 5. Bottom outline of ossuary pit, Marshall site.

(For explanation, see p. 312.)



SHELL ARTIFACTS AND BEADS, VARIOUS CULTURES IN NEBRASKA

1. Shell artifacts, (Rule=6 inches. For explanation, see p. 312.)
2. Types of beads.

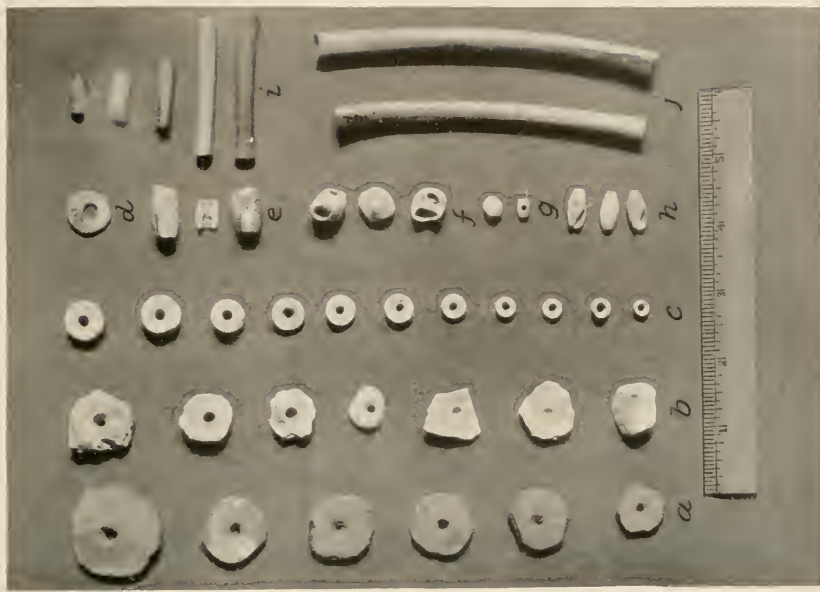

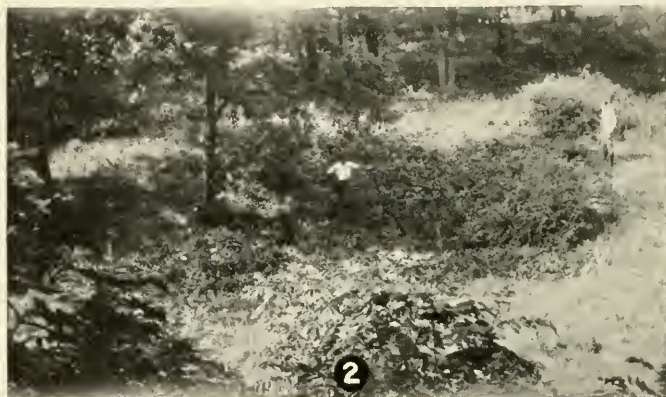

NEBRASKA CULTURE HOUSE SITES

1. House 2, Rock Bluffs. 2, 3. House 1, Gates site.

(For explanation, see p. 312.)



1. In situ.



LARGE POT, HOUSE 2, ROCK BLUFFS, NEBRASKA CULTURE

2. Restored.

(Height of vessel 23½ inches. For explanation, see p. 312.)



NEBRASKA CULTURE POTTERY

1. From Rock Bluffs and Gates sites.
2. Vicinity of Omaha (Gilder collection).

(Rule=6 inches. For explanation, see p. 313.)



NEBRASKA CULTURE RIM SHERDS
(Rule=6 inches. For explanation, see p. 313.)



1. Nebraska culture artifacts.

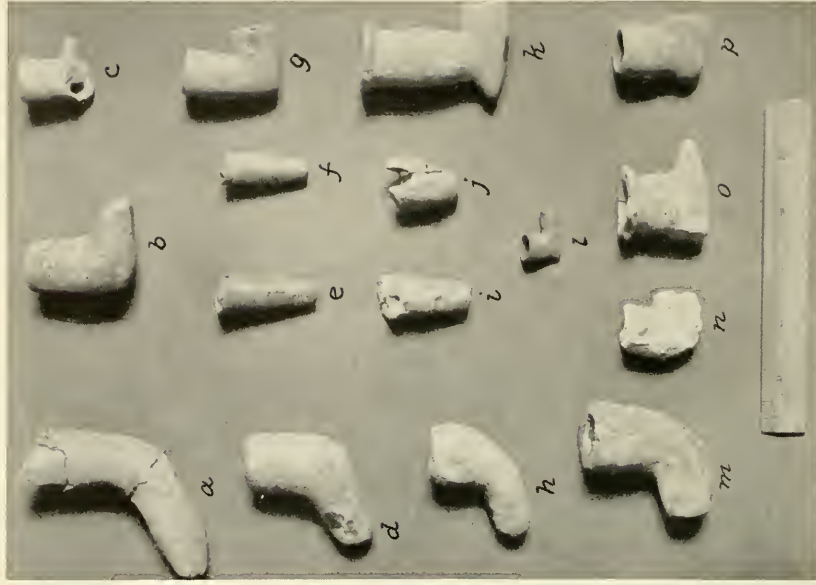

2. Tobacco pipes from various cultures.

(2, rule—6 inches. For explanation, see p. 313.)

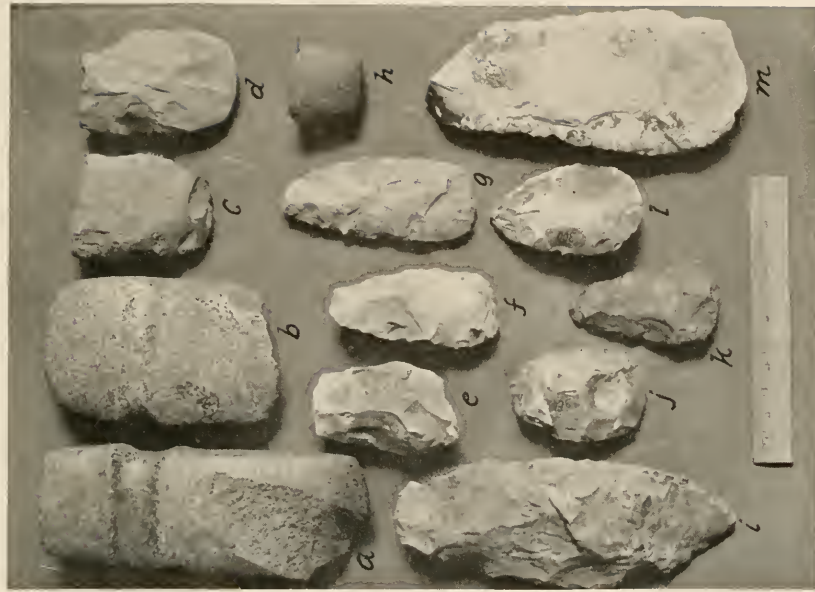

GROUND STONE AND LARGE CHIPPED ARTIFACTS, VARIOUS CULTURES IN NEBRASKA

1. Ground stone implements.

2. Stone axes and celts.

(Rule=6 inches. For explanation, see p. 313.)

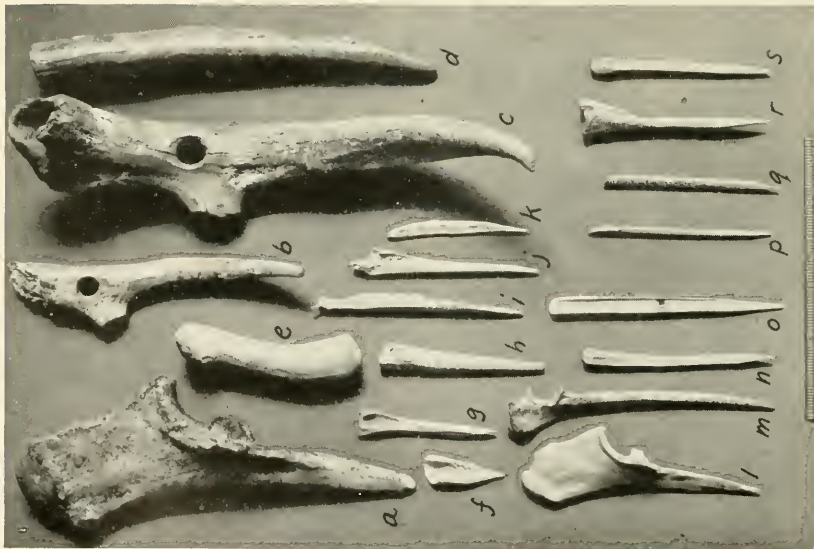

BONE AND ANTLER ARTIFACT TYPES. VARIOUS CULTURES IN NEBRASKA
 1. Mainly Nebraska culture (*d*) Upper Republican culture.

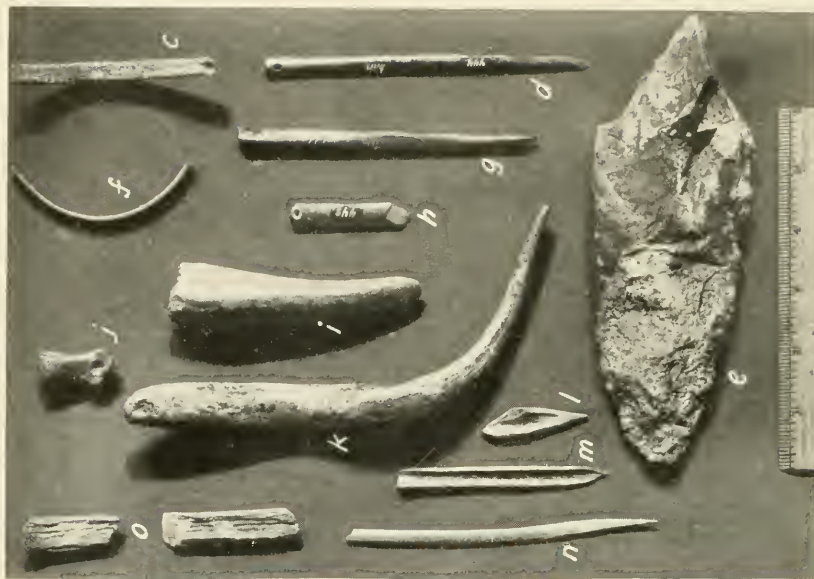

2. Sterns Creek culture implements.

(Rule = 6 inches. For explanation, see p. 313.)



STERNS CREEK CULTURE, WALKER GILMORE SITE

1. Pots, Sterns Creek culture.
2. Sterns Creek canyon.
3. Deep exposures of white ash.
4. Shallow exposure at A (fig. 24).

(1, rule=6 inches. For explanation, see p. 314.)



MOUND AND QUARRY TRENCH, CASS COUNTY

1. "Mound" 1 above Walker Gilmore site.
2. Excavating "mound" 1.
3. Old quarry trench A, Weeping Water site.

(For explanation, see p. 314.)

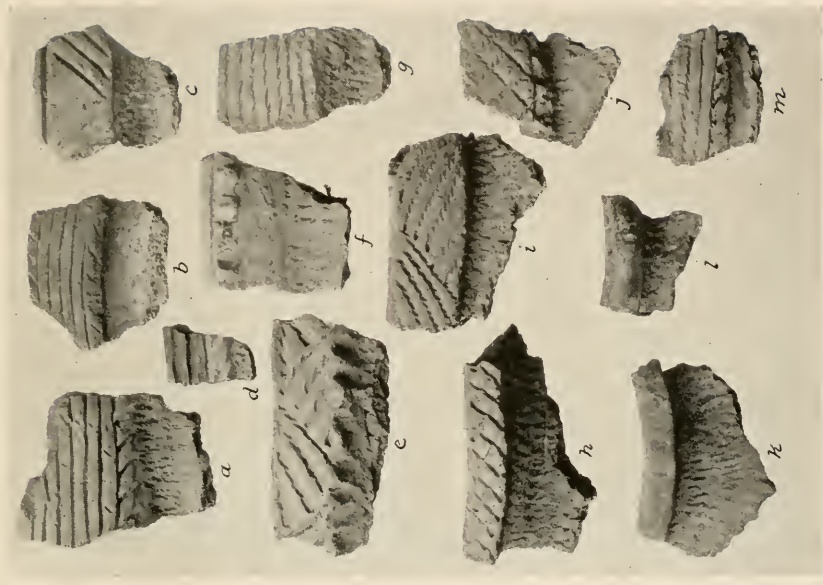

UPPER REPUBLICAN CULTURE ARTIFACTS FROM VARIOUS SITES

- 1. Upper Republican culture artifacts (J. P. Spence collection).
- 2. Rims sherds from Medicine Creek and Sweetwater sites.

(1, not to scale; 2, \times about 3. For explanation, see p. 314.)

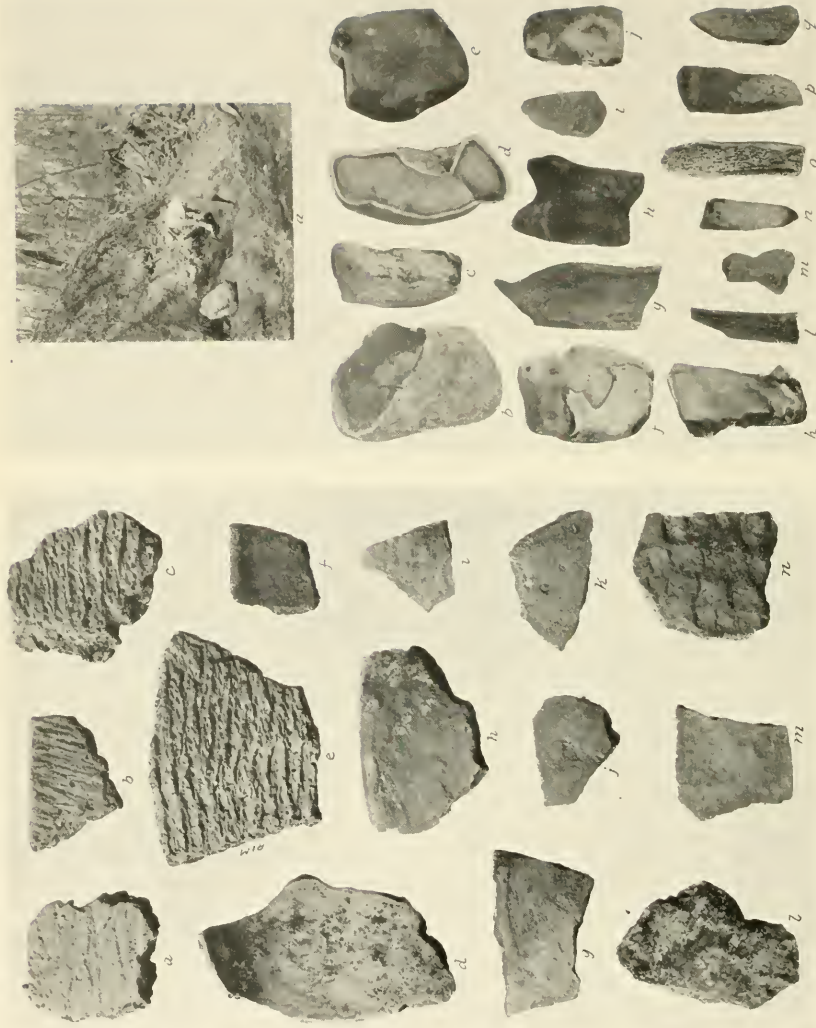

DISMAL RIVER POTSHERDS; AND FOSSILIZED BURNED BONE WITH ARTIFACTS FROM SARPY COUNTY

1. Potsherds from Dismal River (two types). 2. Bird Canyon site, artifacts and bone. (1, about 1; 2, about 1/2. For explanation, see p. 314.)



STRATIFIED SITE ON THE SUMMIT OF SIGNAL BUTTE, SCOTTS BLUFF COUNTY

1. Signal Butte from east.
2. Cross-section showing three levels.
3. Level I on south edge.

(For explanation, see p. 314.)



I. Artifact types, top level (III).



2. Pottery, top level (III); and artifact types, middle level (II).

($\times 1\frac{1}{2}$. For explanation, see p. 315.)

ARTIFACT TYPES FROM TOP LEVEL (III) AND MIDDLE LEVEL (II), SIGNAL BUTTE



ARTIFACT TYPES FROM LOWEST LEVEL (1). SIGNAL BUTTE

1. Chipped stone implement types.

2. Bone, antler and ground stone implement types.

($\times \frac{3}{16}$. For explanation, see p. 315.)

INDEX

A

- Acknowledgments, 2-4
 Aiaouez, 25
 Aiaouway, 42
 "Algonkian" culture, 285, 288, 295
 Algonkian stock, 13, 26
 Allen, quoted, 36, 37
 Alma site, 122-123, 246
 American Philosophical Society, 52
 Angus site, 221, 224, 246, 282
 Animal life of Nebraska, 33-34, 35, 36
 Animals, extinct
 association of artifacts with, 271, 280, 282
 See also Bison; Mammals; Mammoth
 Antiquity
 of Signal Butte site, 236-239
 of Sterns Creek culture, 195-196
 Antler, work in, 60-61, 67, 97-100, 234-235
 Apache, 10, 12-13
 Apana, 19
 Arapaho, 13, 15, 26, 27, 29, 39, 40, 272, 299
 Archeological work
 in Colorado, 293
 in Iowa, 284-289
 in Kansas, 283-284
 in North Dakota, 289-292
 in South Dakota, 3, 289-292
 in Wyoming, 292
 previous, in Nebraska, 40-55
 Arikara, 12-13, 15, 18, 26, 63, 275, 298, 299
 arrows, 267
 villages, 290, 291
 Arkansas River, 12-13
 Artifacts
 antler, 60-61, 67, 97-100, 111, 164, 192, 234-235, 260, 261
 bison hair, 61
 bone, 54, 60-61, 67, 94-97, 102, 110-111, 121, 136, 142-143, 153, 163-164, 191-192, 234-235, 260, 261, 268
 Caucasian, 62, 63, 67
 chipped stone, 59-60, 66-67, 68, 87-94, 102-103, 109-110, 123, 129-130, 134-136, 142, 153, 162-163, 166, 190-191, 202, 216, 221-223, 230-234, 241, 260, 267, 269
 classes of, 54
 copper, 114
 from cache pits, 79, 80
 from refuse heaps, 81
 glass, 61, 62
 ground stone, 59-60, 66-67, 68, 85, 102, 109, 133-134, 140-142, 152-153, 161-162, 166, 190, 230, 241, 260, 268, 269
 metal, 60, 62
 shell, 60, 61, 100, 111-114, 120, 121, 123, 129, 136-137, 235, 262

Artifacts—*Cont'd*

- with extinct animals, 220-224, 271, 280, 282, 293
 wooden, 61, 193, 268
 See also Basketry; Pottery
 "Artifacts," Pliocene, 53, 54
 Assiniboin, 298
 Atsina, 26
 Aughey, Samuel, 43

B

- Bad Land region, Indians of, 39
 Baker, Frank C., 3, 113, 120, 194
 Bandelier, cited, 10
 Barbour, E. H., cited, 2, 44-45, 46, 47, 207, 222
 Barbour and Schultz, cited, 221, 222, 281
 Basketry impressions, 137, 262
 Beads, shell
 from Graham site, 111-113
 manufacture of, 120
 Benrns, Joe E., 141
 Bell, Earl H., 3, 55, 66, 172, 222, 242
 Bell and Van Royen, cited, 220, 221, 222, 282
 Bellevue, mound near, 208, 210
 Bellin, cited, 12-13, 23, 25
 Bengston, Nels A., 3
 Big Nemeha, 22
 Big Sioux River, 12-13, 18
 Bilgery, Father Conrad, 223
 Bird Creek Canyon site, 217-220, 246, 271
 Birket-Smith, cited, 99
 Bishop, A. L., 4, 168, 170
 Bison
 extinct, artifacts with, 219-220, 221, 246, 271, 282, 293, 299
 See also Buffalo
 Blackbird, grave of, 42-43
 Blackfoot Indians, 26, 28, 298
 Black Hills, 18, 27
 Blackman, E. E.
 cited, 28, 43, 45, 47, 144, 199, 203, 204, 206, 208, 209
 work of, 4, 47-48
 Black Padouca, 25
 Blue Earth River region, 22
 Blue Springs, Nebr., 16
 "Blue Water," 12-13
 Bodmer, 11
 Bone, *see* Artifacts; Skeletal material
 Bone work, *see* Artifacts
 Boule, cited, 46, 54
 Bourgmont, 10, 212
 Brackenridge, 11, 291
 Bradbury, 11, 206, 267, 291
 Brooking, A. M., 119, 121, 221
 Brower, cited, 43, 283-284
 Brulé Sioux, 28
 Buffalo
 extermination of, 10, 37-38
 range of, 36

Buffalo Bill's Cave, 116
 Buffalo skull shrine, 63, 64
 Bureau of American Ethnology, 2, 3, 5, 55,
 212, 223, 224, 240
 Burial customs, 174, 205
 Burials, 58, 61, 64, 103, 113, 198-201, 208,
 228, 250, 278, 279
 summary of, 266
See also Ossuaries; Skeletal material
 Burkett site, 43, 48, 62, 63, 64, 67, 246,
 273, 297
 Burnett, E. A., 2
 Burpee, cited, 28
 Bushnell, cited, 20, 51, 55, 144, 205, 206,
 266
 Butte, Nebr., 242
 Butte site, 246, 275

C

Caches, *see* Storage pits
 Caddoan stock, 7, 12, 39, 287, 292
 Camancias, 26
 Cannibalism, possibility of, 174, 265
 "Capaha," 17
 Cape, Robert E., 222
 Cape site, 282
 Carver, 27
 Cataka, 26
 Cat-a-kah, 26
 Catlin, 11, 22
 Ceramics, *see* Pottery
 Champe, John, 4
 Charlevoix, 10, 12-13, 21
 Chau Pawnee, 57
 Cheyenne, 13, 15, 19, 26, 27, 29, 39, 40,
 272, 299
 Cheyenne River, 12-13, 20, 27, 28
 Cheyenne sites, 292
 Child's Point site, 42, 208
 Chipped points
 change in, 279, 280
 classification of, 89
 distribution of, 90
 Yuma type, 280-281
See also Artifacts; Folsom points
 Chipped stone, *see* Artifacts
 Chippewa, 27, 28
 Chittenden, cited, 22
 Chiwere division, 12, 17, 21, 24, 39, 295
 Clarks site, 48, 246
 Climate of Nebraska, 38
 Clovis, N. Mex., 280
 Coffin, C. C., 223
 Coffin, Roy G., 223
 Collot, 12-13, 14, 19, 26, 27
 Colorado,
 archeological work in, 293
 historic tribes of, 27
 Comanche, 10, 12-13, 15, 18, 19, 25, 26, 29,
 39, 212, 270, 272, 273, 298
 Conclusions, 294-300
 Condra, cited, 31
 Condra and Keyser, cited, 31
 Connelley, cited, 16, 26
 Cook, Harold J., 51
 Cordage, 100
 Corn, *see* Maize
 Coronado, 7
 Cottonwood Creek site, 246

Coues, cited, 26
 Covington, Nebr., 18
 Crania, *see* Skeletal material
 Crescent City, mounds near, 209
 Crow, 28, 37, 298
 Crow earth lodge, 28
 Crow migration, 295
 Cultural affiliations, with areas adjacent to
 Nebraska, 282-294
 Cultural classification of archeological re-
 mains, 1, 2
 Culture, affected by environment, 30-40
 Culture sequence, 271-282, 296
 table of, 272
 Cultures, summary of, 245-271
 Cumro site, 246, 271, 280

D

Dakota groups, burial customs of, 266
 Dakota migration, 295
 Dakota tribe, 12, 14, 15, 18, 20, 27, 28, 29,
 37-38, 39, 40, 99, 272
 Daniels, Lee, 3, 243
 Decoration of pottery, 84, 131, 159-160, 188,
 229, 240, 243, 244, 247-248, 252,
 262, 268, 277, 286
 De Land, cited, 267, 289
 De l'Isle maps, cited, 12-13, 16, 22, 24, 25
 Dent, Colo., discovery at, 223
 De Soto, 17
 Des Moines River, 12-13, 22, 42
 Dhegiha division, 12-13, 14, 16, 17, 20, 24,
 39, 206, 295
 Dhegiha migration, 19
 Dismal River culture, 272
 Dismal River region, 212-213
 Dismal River sites, 212-217, 246, 270-271
 Dixon, cited, 17
 Dodge, Richard I., quoted, 37
 Dooley, T., 71
 Dooley site, 69-103
 Dorsey, cited, 16, 17, 18, 19, 20, 21, 22,
 24, 206
 Douglas, Ralph, 4, 79, 81, 82, 84
 Dunbar, cited, 267, 298
 Duncan, C. A., 83
 Du Pratz, 12-13, 21, 23, 25
 Du Tisné, cited, 10, 16

E

Earth lodges, 18, 48-49, 57, 62-63, 64, 73-74
 development of types, 276-277
 excavation of, 63, 74-78, 101-103, 126-
 129, 138-139, 147, 151, 154-157,
 164-165, 166-167, 172-175
 floor plans of, 64, 72, 127, 148, 155
 method of excavation, 73-74, 227-228
 shapes of, 174-175, 240, 249, 262-266,
 274
 walls of, 264
 Earth lodge sites, extent of, 263
 Earthworks, 57, 206
 Eastman, 11
 Effigy heads, 257, 258
 Eiseley, Loren, 3, 241, 242
 "Elephant," fossil, artifact associated with,
 43

Elkhorn River, 12-13, 19, 168, 210, 243,
246, 263
Environment, effect of, on culture, 30-40
Escansaques, 14

F

Fenneman, cited, 31, 39
Figgins, cited, 221, 223, 282
Fletcher and La Flesche, cited, 17, 18, 19,
21, 24, 25, 38, 144, 205, 212
Florence, Nebr., 18, 24
Floyd River, 29
Folsom culture, 224, 271, 272, 279, 280,
282, 293
Folsom points, 223, 224, 279, 280, 281, 282
Foreman, Grant, cited, 16
Fort Collins, Colo., 223, 280, 282
Fowke, Gerard, 50, 51, 207, 209-210, 274
Franklin, Nebr., 83
Fremont, J. C., 27, 29
Fremont, Nebr., 48
Fullerton site, 246
Furry, C. J., 83

G

Garcilasso, cited, 17
Gates, Harold, 144
Gates, J. M., 144
Gates site, 143-168, 246, 255, 263
Gazin, C. L., 3, 235
Genoa, Nebr., 43, 48
Genoa site, 246
Gens de la Fleche Collée, 28
Gens de valch, 27
Gens-di-rach, 27
Gifford and Schenck, cited, 89
Gilder, Robert F.
cited, 4, 40, 42, 44, 45, 46, 49, 69, 204,
250, 251, 255, 257, 260, 261, 262
work of, 48, 49, 144, 168, 170, 207, 208
Gilder collection, 98
Gilmore, G. H., 4, 124, 125, 126, 139, 175,
189, 198
Gilmore, Melvin H., 3, 143, 187, 193
Gilmore, Walker, *see* Walker Gilmore site
Glacial area, 35-36, 272, 295
Indians of, 39
Glenwood culture, 251, 287
Graham, Robert, 103
Graham site, 103-114, 116
Grand Island site, 221, 246, 271
Grand Pawnee tribe, 57
Grand River, 12-13, 16
Grand Saline River, 16
Gravel deposits, artifacts in, 217-220
Gray, Glenn W., 3
Gray site, 48, 62
Green, A. L., cited, 16
Green, Thomas L., 4, 224, 225
Green Bay, Wisc., 17
Greenwood Creek, 222
Gregory, W. K., 51, 52, 53
Griffing site, 283-284
Grinnell, George B., cited, 25, 26, 27, 44,
65, 212, 289, 291
Gros Ventre, 298
Ground stone, *see* Artifacts

H

Habitations
Sterns Creek, 184-187
See also, Earth lodges
Handbook of American Indians, 26
Harahey, 7
Harrington, M. R., cited, 113, 261, 276, 284
Harvard University, 3, 50
Hastings Museum, 83, 124, 221, 242
Hayden, cited, 43
Hellman, M., 51, 52
Hennepin, Father, cited, 19, 21, 28
Henry, Alexander, cited, 27
Hertzler, J. O., 2
Hesperopithecus, 51-55
Hicks, J. D., 2
Hidatsa migration, 295
Hidatsa sites, 292
High Plains area, 32-34
Indians of, 39
Hill, A. T., 3, 4, 51, 55, 56-57, 73, 80, 117,
119, 121, 122, 124, 212, 213, 214,
216, 241
Hill site, 56, 57, 59, 246
Hipparion fauna, 52
Hodge, F. W., cited, 10
Holmes, cited, 43, 44, 65, 66, 141
Hopewell culture, 285
Hopi pottery, 131
Horse Creek, 29, 48, 206
Horse Creek site, 246
Horses
introduction of, 10-11, 18, 30, 296, 297,
298
remains of, 62, 101, 297
House mounds, *see* Earth lodges
House pits, *see* Earth lodges
Hooton, cited, 46
Howard, cited, 280
Hrdlička, cited, 45-46, 47, 207
Hunkpapa, 28
Hyaenarctos, 52

I

Iberville, 21
Ietans, 26
Illinois tribe, 12-13, 21
Indian Hill, 104, 115
Ionia, Nebr., 18, 24
Iowa
archeological work in, 284-289
tribes of, 22, 23, 24, 28, 37
Iowa Point, Kans., mound near, 210
Iowa River, 17
Iowa tribe, 12-13, 15, 17, 18, 19, 20, 21, 22,
23, 24, 50, 205
Irving, 11, 206

J

Jackson, W. H., photographs by, 55
Jefferys, cited, 21
Jicarilla Apache, 25
Joliet, 12-13, 22
Jones, cited, 207
Joyner, Newell, 3

K

- Kaighns Point, 215, 216, 270
 Ka-ne-na-vish, 12-13, 27
 Kansas tribe, 12-13, 14, 17, 19, 20, 21, 23,
 205, 206, 212, 244, 284, 295
 Kansas
 archeological work in, 283-284
 tribes of, 7, 25
 Kansas River, 12-13
 Kaskaias, 26
 Keyes, Charles R., 251, 284, 285, 287, 288
 Kiowa, 26, 29, 298
 Kiowa Creek, 29
 Kirby, Maurice E., 3, 4, 225, 237, 238
 Kitkehahki Pawnee, 16, 57
 Kroeber, cited, 298
 Kurz, 11, 144

L

- Laboratory of Anthropology, Santa Fe, 3,
 224
 Lahontan, cited, 21, 28
 Lake Michigan culture, 289
 La Salle, 19, 62
 La Vérendrye, 10; cited, 28
 Lehn site, 123-124
 Le Raye, cited, 10, 19, 20, 21, 27, 28
 Leshara site, 246
 Le Sueur, 12-13, 21, 22, 25, 28
 Lewis and Clark, cited, 11, 12-13, 20, 21,
 23, 26, 27, 28, 29, 41, 42, 208,
 212, 291
 Lindenmeier site, Colo., 223, 279
 Linton, cited, 63
 Linwood site, 48, 56, 57, 206, 246
 Little Kansas River, 12-13
 Llano Estacado, 10
 Lodges, *see* Earth lodges
 Loess Plains, 35, 272, 294
 Indians of, 39
 Logan Museum of Beloit College, 280
 Long, Major, cited, 11, 12-13, 20, 21, 27,
 29
 Long's Hill mound, 44-47, 51, 207
 Lost Creek district, map of, 70
 Lost Creek site, 246
 Lost Creek village, 69-103
 Loup River, 12-13, 123, 124
 Loup River Pawnee villages, 55
 Lowie, Robert H., 3
 Ludlow cave, S. Dak., 291, 297
 Lugn, A. L.
 cited, 222, 281
 work of, 3, 218, 219
 Lugn and Schultz, cited, 281

M

- Mackenzie, 27
 Maize, 18, 130, 138, 104, 262, 268, 295
 Mallet brothers, 10
 Malroy, C. W., 242
 Mammals, extinct
 with human artifacts, 220-224
 See also Animals, extinct

Mammoth

- archeological period of, 299
 artifacts found with remains of, 223,
 282
 reported association of, with artifacts,
 221, 246
See also "Elephant"

Mandan, 298, 299

Mandan migration, 295

Mandan sites, 290, 291

Maps

- Bird Creek Canyon site, 169
 digest of, 12-13, 14
 Gates site, 145
 Lost Creek district, 70
 Rock Bluffs district, 125
 Saunders site, 169
 showing Nebraska sites, 8
 showing Nebraska tribes, 9, 38
 U. S. exploring party, 1803, 16
 Walker Gilmore site, 176
 Weeping Water site, 199
 Marquette, cited, 12-13, 19, 21, 22, 25
 Marshall site, 116-122, 246
 Matthew, W. D., 51, 52
 Max, Nebr., site near, 241-242, 246
 Maximilian of Wied, Prince, 11, 291
 McClaine site, 48, 246
 McGee, cited, 21, 22, 23
 McGrew, Paul, 3
 McKern, 1, 289
 Medicine Creek sites, 242, 246
 Merrill, Moses, cited, 23, 24
 Merrill, Samuel P., cited, 23
 Meserve, F. G., 221
 Mill Creek culture, 287, 288, 295
 Miller, Gerrit S., Jr., 3, 52, 236
 Miniconjou, 28
 Minnesota, 12-13, 22, 23, 24, 26, 27, 37
 Miocene period, 225
 Mississippi River, 28
 See also Upper Mississippi culture
 Missouri River, 18, 21, 22, 23, 24, 25, 26,
 27, 29, 51, 73, 124, 179, 209, 246,
 263, 274
 Missouri tribe, 12-13, 15, 17, 22, 23, 205
 Molluscan remains, 100-101, 137-138, 194
 Monier, Jean Baptiste, 21
 Montgomery, cited, 289
 Mooney, cited, 25, 27, 29, 39
 Moore, cited, 261, 262
 Moorehead, cited, 284
 Morris, cited, 132
 Morrison, Frank, 3
 Mounds, 40, 41-42, 44, 170-172, 193-205,
 274, 290
 formation of, 211
 problem of, 205-211
 Munson Creek site, 123, 246
 Murie, cited, 63

N

- Naskapi stonework, 85
 National Research Council, 5, 240
 N de Fer maps of 1718, 19
 Nebraska
 geographic areas of, 32
 physical classification of, 30-31

Nebraska—*Cont'd*

- previous archeological work in, 40-55
- tribes of, 9, 14-29, 38-40, 205, 272-273
- Nebraska Archeological Survey, 4, 240
- Nebraska culture, 49, 50, 177, 180-182, 272, 288, 295
 - summary of, 250-267, 274-275
- Nebraska culture pottery, Sterns' classification of, 254
- Nebraska sites, table of, 246
- Nebraska State Historical Society, 47, 240
- Nebraska State Museum, 49, 119, 251, 261
- Nehawka, Nebr., 43, 210
- Nehawka quarries, 203
- Nelson, N. C., cited, 54
- Nemaha reservation, 24
- Nemaha River, 12-13, 41, 210
- Nemaha site, 50-51
- Neosho River, 16
- Niobrara River, 12-13, 18
- North Dakota
 - archeological work in, 289-292
 - Cheyenne in, 27
- North Dakota Historical Society, 289
- North Platte River, 246
- North Platte sites, 246
- Nuttall, 11

O

- Oglala, 28
- O'Heeron, Michael, 3
- Ohio River, 206
- Oklahoma, 24
- Oligocene period, 225
- Omaha City, 48, 211, 255
- Omaha Creek, 12-13
- Omaha Public Library, 49, 98, 260, 261
- Omaha tribe, 12-13, 14, 15, 17, 18, 20, 21, 22, 23, 25, 29, 38, 39, 40, 55, 205, 206, 211, 212, 272, 295, 298
- Omaha village, 48, 144
- Omaha villages, traditional, 18
- Omaha World-Herald, 44
- Oñate, Juan de, 14
- O'Neill, Nebr., sites near, 243, 246
- Oneota culture, 284, 285, 288
- Osage River, 21
- Osage tribe, 17, 20, 23, 206, 284
- Osage ware, 50
- Osborn, Henry Fairfield, 44, 51, 52, 53, 207
- Ossuaries
 - Alma site, 122-123
 - Lehn site, 123-124
 - Marshall site, 116-122
 - Munson Creek, 123-124
 - Prairie Dog Creek, 103-114
 - Republican River, 122-123
 - Saunders site, 168-175
- O'Sullivan, J. B., 4, 175, 243, 244
- Oto River, 12-13
- Oto tribe, 12-13, 15, 17, 18, 21, 22, 23, 29, 39, 40, 42, 50, 55, 205, 206, 211, 272, 295, 298
- Oto village, 48
- Otontas River, 21
- Otteaus, 42
- Otteauze, 42
- Over, W. H., 290, 291
- Ozark Bluff Dweller culture, 284

P

- Padouca, 12-13, 18, 25, 26, 39, 212
 - See also* Black Padouca; White Padouca
- Paducar, 26
- Pahoutet, 12-13, 25
- Paint Creek Site, 283
- Palmer site, 246
- Pana, 12-13, 19, 22
- Paniassa, 19
- Panimaha, 19
- Panis, 12-13
- Panis blanc, 12-13
- Panis noirs, 12-13
- Panis old village, 16
- Panis Piqués, 16
- Panis River, 21
- Papillion Creek, 20, 48, 143, 144, 208, 263
- Park, Edward, 284
- Parker, cited, 261
- Pawnee, 7, 10, 12-13, 15, 21, 22, 23, 26, 29, 37, 38, 39, 40, 44, 205, 272, 273, 275, 276, 298
- Pawnee burials, 58, 61, 64, 205
- Pawnee culture, 55-68, 272, 273-274, 297
- Pawnee "Grand Village," 12-13, 26
- Pawnee sites, 16, 62
 - historic, 246
 - protohistoric, 246
- Pawnee villages, 43, 48, 50, 56, 206
- Peabody Museum of American Archaeology and Ethnology, 49, 250, 257, 262-263
- Pénāčĕka, 25
- Perrin du Lac, 10, 12-13, 20, 21, 26
- Pike, Zebulon, 11, 12-13, 26, 48, 51
- Pipes, summary of types of, 259-260
 - See also* Artifacts
- Pipestone quarries, Minnesota, 18
- Plains Archeological Conference, 287
- Plains culture, 299-300
- Plains tribes, environment of, 30-40
- Plank, Pryor, 284
- Plants, native, of Nebraska, 33, 34, 35, 36
- Platte River, 12-13, 21, 22, 23, 26, 27, 221
- Pleistocene period, 53, 221, 236, 272, 281, 282, 294
- Pliocene period, 51, 52, 53, 54
- Pollard, Isaac, 43
- Pomo beadmaking, 120
- Ponca, 12-13, 14, 15, 17, 18, 19, 20, 21, 23, 25, 29, 39, 40, 55, 206, 211, 272, 295, 298
- Ponca Creek, 12-13, 21, 206, 208
- Ponka, Pawnee, and Oto reservation, 22
- Pope, Saxton, cited, 99
- Pottery, 44, 50-51, 56, 58-59, 61, 64-66, 68, 82-85, 102, 108-109, 124, 129, 130-133, 139-140, 151-152, 158-161, 165-166, 173, 180-181, 187-190, 215-216, 229-230, 240-241, 243, 247, 248, 251-260, 268, 275, 277, 279, 285-286, 291, 293
- Poynter, C. W. M., 46, 168, 170
- Prairie Dog Creek district, 104, 116
- Prairie Dog Creek site, 246
- Prairie Sioux, 28
- Prosthennops, 53
- Proudfit, cited, 209
- Pueblo revolts, 10
- Puncas, 21

Q

- Quapaw, 17, 18, 19, 206
 Quarry sites, aboriginal, 43-44, 203-205
 Quivira, 7, 10

R

- Red Cloud, Nehr., 56
 Red River, 12-13, 16
 Refuse heaps, 81-82, 130
 Renaud, E. B., cited, 215, 242, 280, 281,
 292, 293
 Republic, Kans., 48
 Republican Pawnee, 16, 57
 village, 48, 51
 Republican River, 12-13, 69
 ossuaries, 116-123
 Reynolds, Robert L., 3, 217
 Richardson County, 41
 Riggs, A. L., 21
 Roberts, F. H. II., Jr., 3, 223, 282, 293
 Robinson, cited, 289
 Rock Bluffs site, 124-143, 246, 255
 Romer, cited, 281
 Ruby, Nebr., mound near, 208
 Rulo site, 246, 284, 288
 Ryan, Michael, Jr., 223

S

- Sac and Fox reservation, 22
 Saline Creek, 16
 Sand Hills area, 34, 39, 272
 Sans Arc, 28
 Santee, 28
 Santee Dakota, 15
 Sauk and Fox, 15, 23
 Saunders site, 168-175, 210, 246
 Savannah, Nebr., 16
 Schenck, cited, 89
 Schultz, Berstrand, 3, 115
 Schultz, C. B.
 cited, 221, 222
 work of, 103, 132, 189, 220
 Schultz and Barbour, cited, 281
 Schuyler site, 48, 62, 63, 64, 66, 67, 246,
 273, 297
 Sears, Paul B., 4, 222, 223, 237, 238
 Sedentary Siouan culture, 272
 Setzler, Frank H., 1, 3
 Shea, cited, 12-13, 22, 25, 28
 Shell Creek, 12-13
 Shellwork, *see* Artifacts
 Shetrone, 40, 207, 262
 Shimek, cited, 43, 45, 46, 47, 207
 Shine, Father M. A., 47
 Shoshonean stock, 13, 212
 Signal Butte cultures, 269-270, 272, 278-280
 Signal Butte excavations, method employed
 in, 227-228
 Signal Butte site, 3, 224-239, 246, 280, 281
 Simmerman, L. E., 4
 Simpson, E. S., 224
 Siouan tribes in Nebraska region, 12, 16,
 22, 37, 39
See also Sedentary Siouan culture
 Sioux River, 12-13

Sites

- classified, 246
 excavated, 68-69
 grouped according to cultures, 245, 246
 stratified, 246
 unclassified, 246
 Skeletal material
 animal, 62, 67, 100-101, 137-138, 153,
 173, 194, 219, 220-224, 228, 235-
 236
 human, 44-46, 47, 106-107, 115, 119,
 122-124, 139, 170, 171, 173-174, 183-
 184, 201, 228
 Skidi Pawnee, 16, 19
 Skidi sites, 48, 59
 Skinner, cited, 24
 Smith, Elliot, 52
 Smith, Harlan L., 242, 292
 Smith, T. P., cited, 10
 Smithsonian Institution, 2
 Smoky Hill River, 15, 26
 Snake Creek fossil beds, 52, 53, 54
 Solomon River, 12-13, 26
 South Dakota
 archeological work in, 3, 289-292
 tribes of, 12-13, 20, 27, 29
 South Dakota Historical Society, 289
 South Platte River, 27
 "Spanish Diggings," 292
 Spavinaw Creek, 16
 Spence, Gene P., 4, 79
 Spence, Karl L., 4, 71, 82, 101-102
 Spinden, cited, 289
 Spring Creek site, 221, 246, 271, 281
 Sta-e-tan, 26
 Standing Rock Reservation, 99
 Sterns, Frederick H.
 cited, 40, 44, 46, 49, 60, 131, 175,
 181, 182, 184, 203, 207, 208, 210,
 251, 252, 255, 257, 260, 261, 262,
 276
 work of, 3, 49-50, 125, 126, 175, 176,
 177, 178, 197, 250, 276, 284
 Sterns Creek, 175, 176-177
 culture, 50, 180, 184-196, 267-268, 272,
 274, 278, 287-288, 295
 Stirling, cited, 289, 291
 Stonework, *see* Artifacts
 Storage pits, 57, 63, 76, 78-81, 129-130, 157-
 158, 228-229, 249-250, 265
 Strong, cited, 212, 220, 221, 224, 240
 Strong, Schenck, and Steward, cited, 89
 Sutaio, 26
 Swanson, Ray, 281
 Swanton, John R., cited, 3, 16, 17, 27, 28,
 298
 Sweetwater site, 240-241, 246

T

- Tappage Pawnee villages, 16
 Tetaus, 26
 Teton Dakota, 12-13, 28, 29, 298
 Thoburn, Jos. B., 284
 Thomas, Cyrus, cited, 40
 Thompson, cited, 27
 Thomson, A., 52, 53
 Todd, cited, 43, 199
 Tonkawa, 10
 Treaties, United States, 20

Tribes of Nebraska region, 9, 12-13, 14-29,
38-40, 205, 272-273
Truteau, 10
Two Kettle band, 28

U

Udden, J. A., 283
United States National Museum, 3
University Museum at Vermillion, S. Dak.,
291
University of California, 3
University of Illinois, 4
University of Michigan, 3
University of Nebraska, 2, 3, 44, 48, 218
University of Nebraska Archeological Sur-
vey, 3, 49, 55, 62, 139, 197, 210,
212, 224, 250
University of Oklahoma, 4
University of South Dakota, 289
University of Wisconsin, 3
Upham, cited, 43
Upper Mississippi culture, 2, 289
Upper Missouri area, 289-290
Upper Republican culture, 245-250, 266-267,
272, 274, 275-277, 287, 291
Upper Republican sites, 246
Upson, F. W., 2

V

Van Royen, W., 3, 238
Vegetal remains, 143, 193-194, 262, 268
Vermillion Conference of Plains Archeolo-
gists, 289, 290
Vinita, Okla., 16
Von Kuelen maps, 19
Vosy-Bourbon, 53

W

Walker Gilmore site, 49, 69, 175, 210, 225,
246, 267-268, 272, 275
suggestions for excavations at, 196-198

Wallace "mound," 208, 210
Ward, H. B., cited, 45
Wedel, Waldo, 1, 3, 10, 16, 19, 39, 48, 50,
55, 56, 58, 62, 63, 65, 205, 206, 240,
242, 243, 273, 283
Weeping Water Creek, 22, 210, 211, 263
Weeping Water site, 198-205, 246
Wetmore, A., 3, 236
White Padouca, 12-13, 25
White River, 12-13, 26
Wichita Indians, 7, 12-13, 15, 16, 19, 297
Wildcat Hills, 215
Wilder, cited, 52
Will, George F., 289, 290
Will and Hyde, cited, 24
Will and Spinden, 261, 290
Wilson, Thomas, cited, 89
Winchell, cited, 43
Winnebago, 15, 17, 21
Winship, cited, 10
Wisconsin, archeological work in, 289
Wissler, Clark, cited, 10, 294
Wolcott, R. H., cited, 31, 32, 39
Wolf Creek site, 284
Woodruff, E. G., cited, 204
Woodward, Smith, cited, 52
Woodworking, *see* Artifacts
Wright, Dana, 290
Wyoming, tribes of, 27
archeological work in, 292

Y

Yankton bands, 28
Yankton Dakota, 12-13
Yankton Dakota village, 29
Yarmouth interglacial stage, 221
Yocum, 168
Yuma type chipped points, 280-281, 293
Yutan site, 12-13, 23, 48, 206

Z

Zimmerman, cited, 42, 50, 207, 284



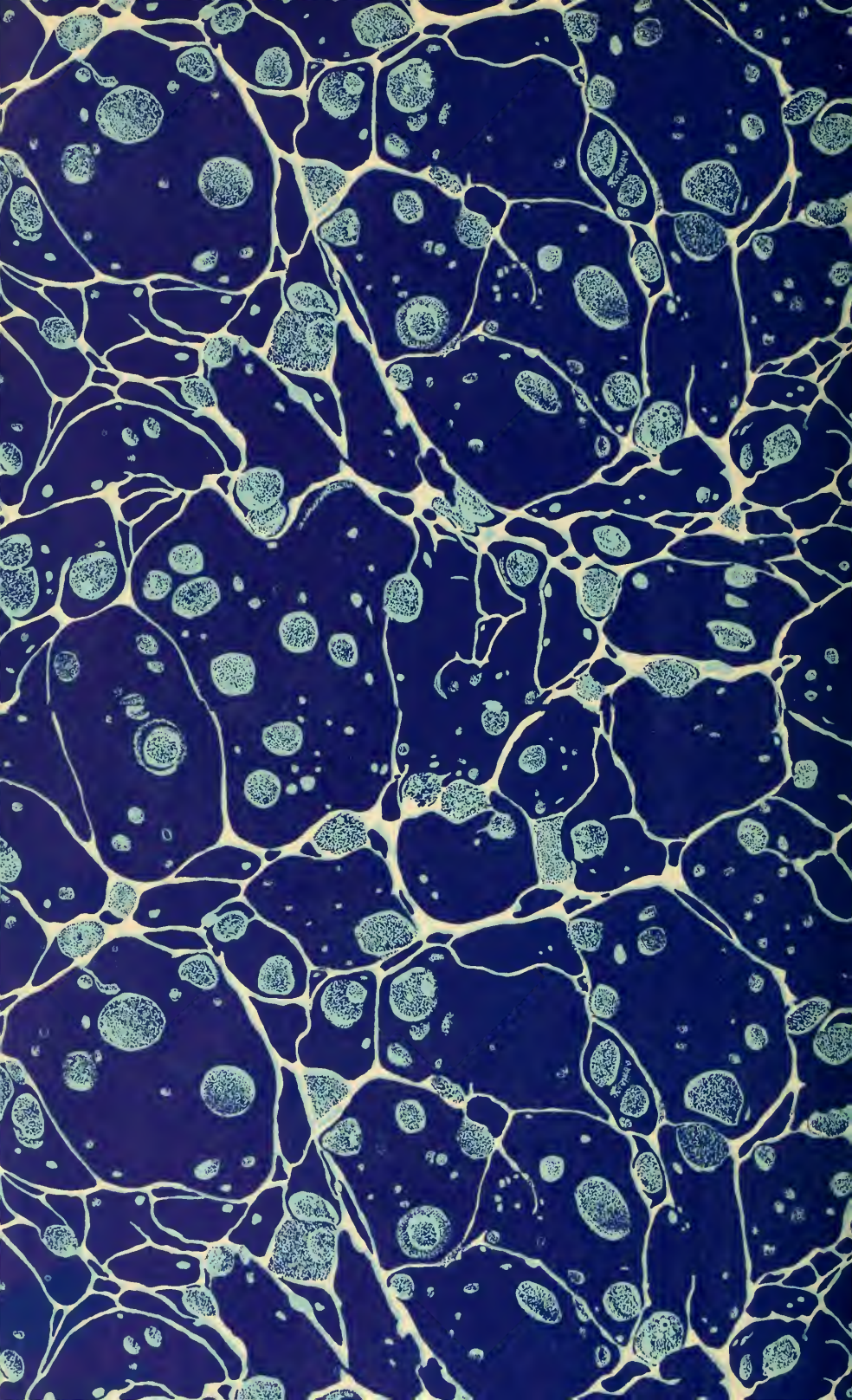

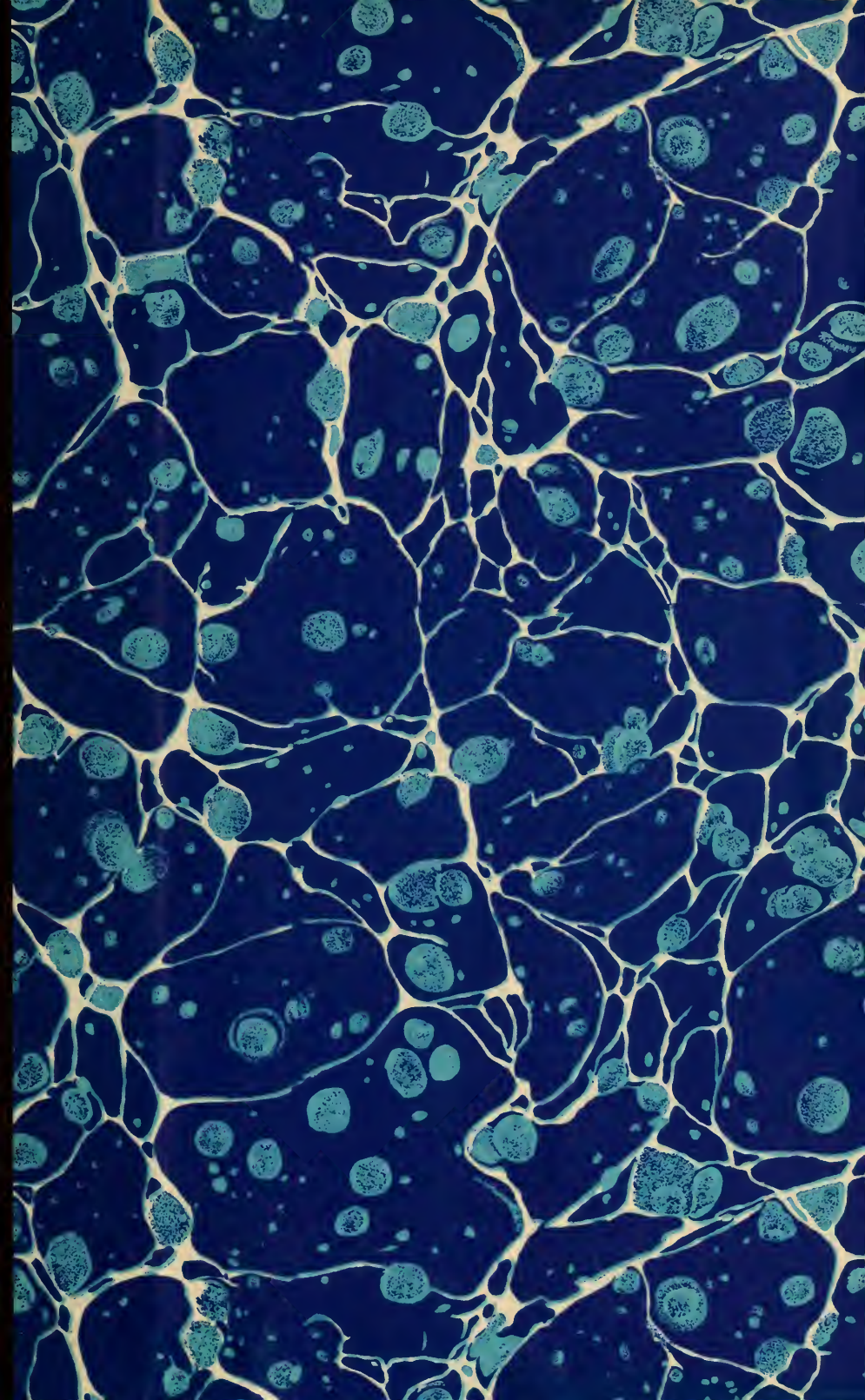

SMITHSONIAN INSTITUTION LIBRARIES



3 9088 00692 7107