

NPS ARCHIVE
1965
CARRETTA, A.

ACOUSTICAL EFFECTS IN A
NEON GLOW DISCHARGE

ALBERT A. CARRETTA
and
WILLIAM N. MOORE

DUDLEY KNOX LIBRARY
NAVAL POSTGRADUATE SCHOOL
MONTEREY, CA 93943-5101

ACOUSTICAL EFFECTS
IN A NEON GLOW DISCHARGE

Albert A. Carretta, Jr.
and
William N. Moore

ACOUSTICAL EFFECTS IN A NEON GLOW DISCHARGE

by

Albert A. Carretta, Jr.

Lieutenant, United States Navy

and

William N. Moore

Lieutenant, United States Navy

Submitted in partial fulfillment of
the requirement for the degree of

MASTER OF SCIENCE
IN
PHYSICS

United States Naval Postgraduate School
Monterey, California

1965

~~THESE~~
C2118

NPS ARCHIVE
1965
CARPETA, A.

ACOUSTICAL EFFECTS IN A NEON GLOW DISCHARGE

by

Albert A. Carretta, Jr.

and

William N. Moore

This work is accepted as fulfilling
the thesis requirements for the degree of

MASTER OF SCIENCE

IN

PHYSICS

from the

United States Naval Postgraduate School

ABSTRACT

The pressure oscillations accompanying the moving striations in the positive column region of a neon filled discharge tube were observed using a specially constructed and calibrated condenser microphone probe. During stable discharge conditions when the moving striations could be observed optically, pressure amplitudes measured were between 0.02 and 0.2 dynes/cm², depending upon ambient pressure and discharge current, with a frequency which was always at the repetition rate for the striations. Frequency was observed to be a function of pressure and current. For any given condition of pressure and current, only one frequency was observed, suggesting excitation of a "normal mode". A theory to explain such a "normal mode" excitation in the discharge is postulated.

PREFACE

The authors would like to extend their thanks for many hours of advice and help to Dr. O. B. Wilson and Dr. H. Medwin and to the Physics Department technical and shop personnel: Mr. Harold Whitfield, Mr. Milton Andrews, Mr. Robert Moeller, Mr. Jan Van Gastel and Mr. Kenneth Smith for their work and assistance in the design and manufacture of the acoustic and electronic equipment, the vacuum system and the discharge tube.

TABLE OF CONTENTS

<u>Chapter</u>	<u>Title</u>	<u>Page</u>
	Abstract	ii
	Preface	iii
	Table of Contents	iv
	List of Illustrations	v
I	Introduction and Scope of the Experiment	1
II	Experimental Equipment	4
III	Microphone Calibrations	11
IV	The Glow Discharge	24
V	Discussion of the Experiment	27
	Bibliography	38

LIST OF ILLUSTRATIONS

<u>Figure</u>	<u>Subject</u>	<u>Page</u>
2.1	General Arrangement of Discharge Tube.	8
2.2	Electrical circuit for Discharge Tube.	9
2.3	Details of 1" microphone mounting, vacuum seal assembly and extension.	10
3.1	Electrical circuit for calibration by electrostatic actuator.	17
3.2a	Sensitivity of $\frac{1}{2}$ " microphone without extension.	18
3.2b	Sensitivity of $\frac{1}{2}$ " microphone at pressure of 10 Torr.	19
3.3	Sound source and calibration cavity details.	20
3.4	Circuit diagram for comparison calibration .	21
3.5	Sensitivity of 1" microphone and probe. Effect of varying geometry at atmospheric pressure.	22
3.6	Sensitivity of 1" microphone with probe.	23
5.1	Frequency vs. current curves for observed moving striations.	37

INTRODUCTION
AND
SCOPE OF THE EXPERIMENT

Investigation of the causes and effects of moving striations in gaseous glow discharges has been a continuing project at the U.S. Naval Postgraduate School for several years. Most recently, the work of Partlow¹ indicated a new technique for investigating discharge conditions through the use of a condenser microphone.

Moving striations were first reported in 1874 in a hydrogen discharge by a German, Wullner, using rotating mirror techniques. Two years later Spottiswood extended Wullner's work and found the existence of moving striations in several different gases. Not until 1925, however, was there a significant improvement in experimental technique when Langmuir² developed the theory of a small probing electrode that allowed the meaningful interpretation of the behavior of glow discharges. Radiofrequency receiving equipment and time resolved spectroscopy have been used as investigative tools but neither has gained the popularity of the Langmuir probe. With the advent of better electronic equipment, the photomultiplier tube and the cathode ray oscilloscope have been added to the research techniques. A more thorough history of the moving striation phenomenon has been presented by Cooper.³

¹Partlow, J.G. Measurements of Acoustic Pressures Associated with Moving Striations in a Neon Glow Discharge. MS Thesis, USNPGS, 1963.

²Langmuir, I. and Mott-Smith, H.M. Theory of Collectors in Gaseous Discharges. Phys. Rev., v. 28, 1926: 727

³Cooper, A.W. Moving Striations in the Inert Gases Glow Discharges. PhD Thesis, Queens University of Belfast, 1961.

Several theories have been proposed concerning the ultimate cause of moving striations. However, none have been verified in full. One relatively new concept, first proposed by Watanabe and Oleson,⁴ relates the moving striations and neutral molecule density waves. This development was followed up by Robertson and Hakeem⁵ who demonstrated the dependence of moving striations on neutrally charged metastable atoms in the positive column of the discharge.

Based on this proposed theory of traveling density waves in a discharge, Partlow undertook his work using a condenser microphone as a primary tool. This work seeks to follow the path pioneered by Partlow by refining the procedures and apparatus to eliminate several problem areas and to attempt to relate the acoustic effects observed to the well-known discharge parameters.

The planned procedure for this investigation was to use three types of probes and to compare the data obtained from them to determine the electrical, optical, and acoustical properties of the discharge. Two condenser microphones were used to investigate alternating pressure conditions such as frequency, amplitude of pressure waves and identification of possible modes of vibration within the tube. One microphone was mounted at the end of the tube on the axis of the tube. The other microphone with a specially designed probe arrangement was mounted on the side wall of the tube perpendicular to the axis. A Langmuir probe was mounted on the side wall of the tube in the same

⁴Watanabe, S. and Oleson, N. L. Traveling Density Waves in Positive Columns. Phys. Rev., v. 99, Sept. 1955: 1701-1704

⁵Robertson, H. S. and Hakeem, M. A. Moving Striations in a Glow Discharge Plasma. Proceedings of the Fifth International Conference on Ionization Phenomena in Gases. North Holland Publishing Co., 1962: 550.

plane as the microphone probe. The Langmuir probe was to be used for investigation of the electrical properties of the discharge. A movable photomultiplier tube was used to measure the frequency of the moving striations. The usual position of the photomultiplier was such that all three investigative probes were in same plane perpendicular to the discharge tube axis.

EXPERIMENTAL EQUIPMENT

2.1 Discharge Tube.

The general arrangement of the discharge tube is presented in Fig. 2.1. It was fabricated from pyrex tubing of two inches nominal inside diameter and with an overall length of 37 inches. The tube and its end caps were fitted with appendages for housing two microphones, a Langmuir probe and the vacuum system connections. Annealed tungsten wire spiral electrodes were mounted on a rigid frame with interelectrode distance fixed at 13.75 inches. The cathode was shielded with a tantalum cylinder in order to improve the discharge conditions. This configuration would not permit variation of the discharge length, but did permit and facilitate examination of conditions along a portion of the length of the discharge by moving the discharge column relative to the sensors. Iron cores sealed in glass permitted the movement of the electrode carriage and control of the Langmuir probe radial position in the discharge column.

2.2. Discharge Circuit

The discharge conditions were controlled by the circuit shown in Figure 2.2. The main power supply was a Kepco DC voltage regulated supply which provided a source of 0-1000 volts regulated to within 0.1 volt with less than three millivolts ripple. A variable resistance in series allowed glow discharge operation with currents in the milliamperage range. The microphones and Langmuir probe were maintained at ground potential. In order to vary the

potential of the grounded microphones with respect to the discharge, a 0-500 volt DC power supply was used to shift the potential of the main power supply relative to ground.

2.3 Vacuum System

The discharge tube was evacuated by "O" ring sealed joints to a metal vacuum system consisting of a 3/4 h.p. Kinney mechanical fore pump with a five cu. ft./min. capacity, a 750 watt oil diffusion pump with a liquid aid filled cold trap and a water cooled baffle.

Four static pressure measurement devices were installed. An oil filled manometer, an ionization gauge and a thermocouple gauge monitored the pressure near the glass to metal "O" ring connection. A second thermocouple gauge monitored the pressure in the diffusion pump fore line.

In order to reduce acoustical coupling effects of a branch tube on the otherwise uniform discharge tube walls, the pump out line was fitted with a movable plug that permitted closure of the discharge tube at the wall during periods of experimentation. The plug was an iron core sealed in glass and was moved by means of a magnet. The discharge tube end caps were sealed to the main tube by means of Viton "O" rings and secured with aluminum clamps. This method was particularly desirable in order to permit convenient changes of the electrode system. This joint could also withstand heating of the tube for outgassing purposes which was not possible with ground glass and grease joints. The microphone assemblies were inserted in the vacuum system by an "O" ring external seal and a pressure differential seal shown in Figure 2.3.

This procedure removed the cathode follower from the vacuum system and also eased the problems involved with electrical noise interference by allowing better cooling of the cathode follower.

2.4 Measurement Equipment.

The primary measurement device in the discharge tube was a Bruel and Kjaer Type 4132 (one inch) condenser microphone, mounted as shown in Figure 2.3. A special probe cap for the microphone was designed. (See Figure 2.3 for details.) Through this cap and a short, small aperture in the tube side wall the microphone was coupled to the discharge. A Bruel and Kjaer power supply provided the voltages for the cathode follower and the microphone.

Discharge conditions at the location of the primary microphone were also detectable by means of a Langmuir probe circuit and by means of a photomultiplier tube to detect fluctuations in the luminosity of the discharge column.

A second condenser microphone, a Bruel and Kjaer Type 4134 (one half inch), was mounted in one of the end caps of the discharge tube. The vacuum seal for this unit was similar to that for the primary microphone. The purpose of this sensor was to detect pressure fluctuations that might aid in identifying the possible acoustic modes of vibration excited by the discharge within the tube.

Signal processing of the acoustic signal from the primary microphone included unamplified passage through the power supply, filtering through a Hewlett-Packard 302 Wave Analyzer, and display on a Tektronix 536 dual beam oscilloscope. The photomultiplier tube output after amplification was also displayed on the oscilloscope.

Copper shielding of all power and microphone signal leads was required in order to reduce the effect of random electrical noise resulting from the discharge and laboratory electrical radiation. Wiring internal to the discharge tube was shielded by ceramic beading to isolate it from the effects of the discharge field.

In order to protect the diaphragm of the primary microphone from ion bombardment a fine conducting wire mesh was placed over the coupling hole in the microphone probe assembly.

Microphone calibration procedures and results are presented in Chapter III.

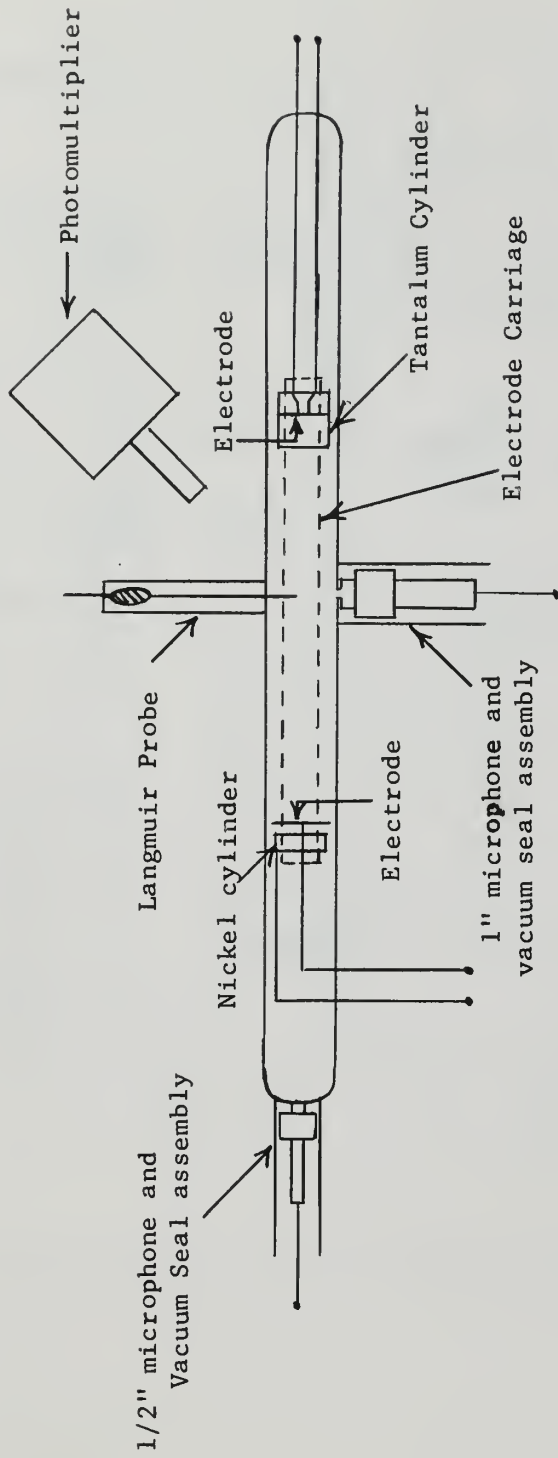

Fig. 2.1. General arrangement of discharge tube.

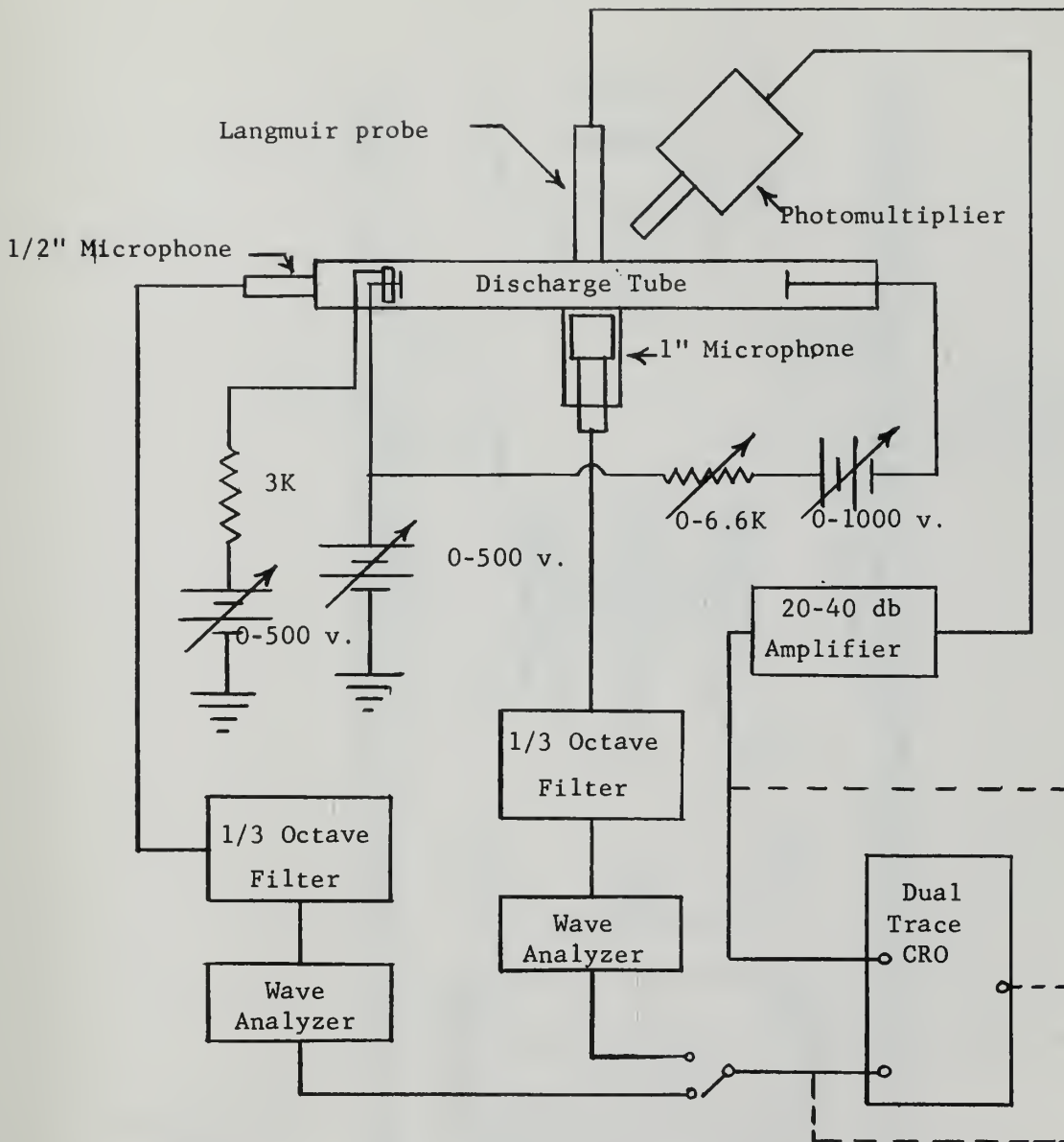

Fig. 2.2. Electrical Circuit for Discharge Tube

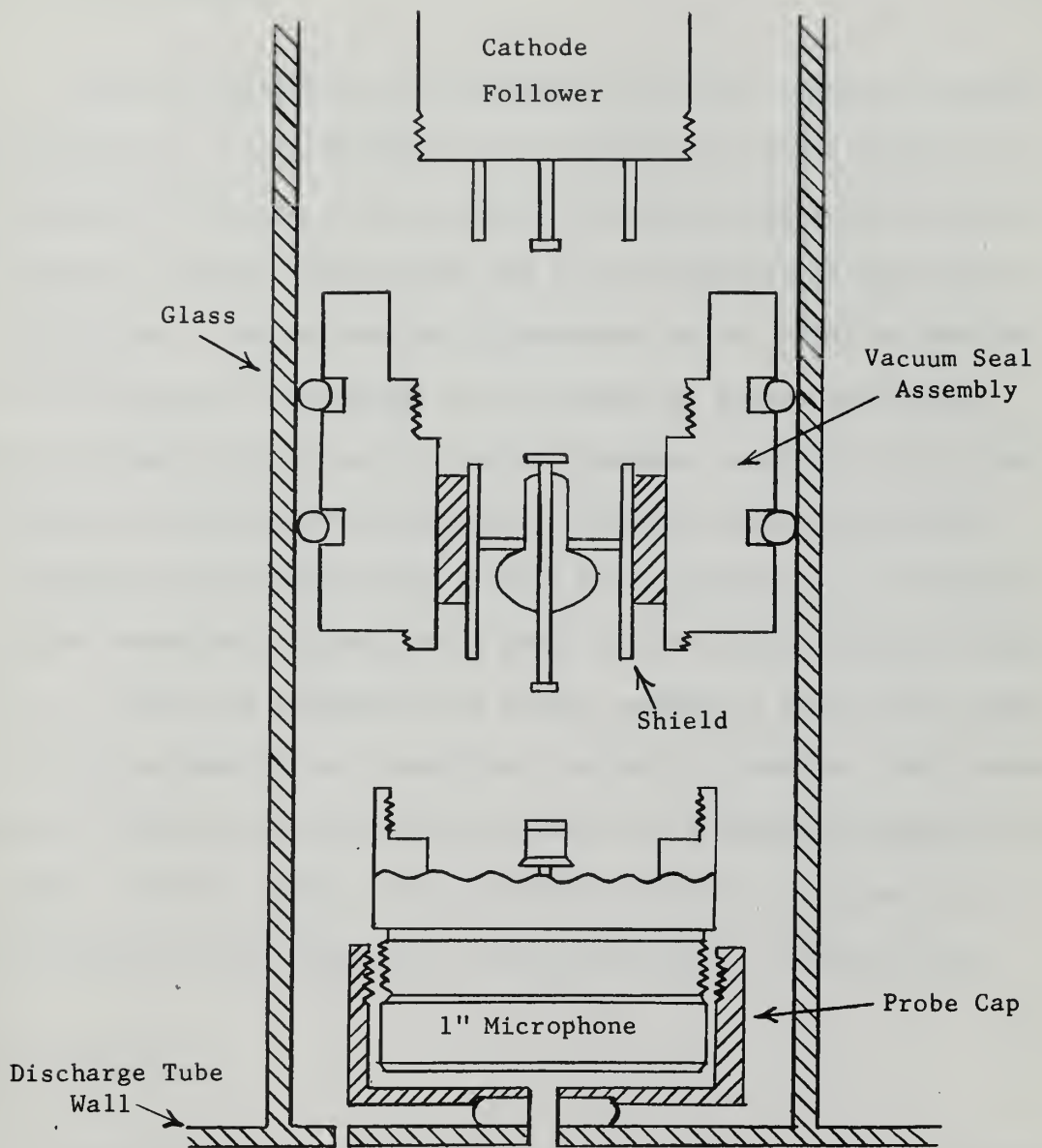

Fig. 2.3. Details of 1" microphone mounting, vacuum seal assembly and extension

MICROPHONE CALIBRATIONS

3.1 Introduction

An investigation of the pressure fluctuations caused by moving striations in a glow discharge using acoustical methods requires an accurate calibration of the condenser microphone and probe at various pressures in order to determine the actual magnitude of the pressure fluctuations. During previous experimentation at USNPGS by Partlow in 1963 several shortcomings of the acoustical system were noted. The foremost of these was the uneven frequency response of the Altec 21BR 150 microphone and probe used. Several resonances and anti-resonances were present which created strong dependence on frequency of the acoustical pressure which made reliable interpretation impossible. In order to eliminate this uneven response a significant amount of time was devoted to determining a suitable microphone probe geometry and to obtain an accurate calibration of the microphone mounted in the probe. For this reason, the calibration procedure and results will be presented more extensively than would normally be appropriate.

3.2 Procedure.

The calibration was accomplished by a comparison method in which a Type 4132 (one inch) microphone with probe cap and vacuum seal assembly is compared with a previously calibrated Type 4134 (one-half inch) microphone in a small coupling cavity. The response curves of the one half inch microphone were determined by an electrostatic

actuator method at pressures ranging from 0.5 Torr (One Torr is one millimeter of mercury) to atmospheric pressure and at frequencies from 500 cps to 30 Kcps.

The electrical circuit for the calibration by electrostatic actuator is shown in Figure 3.1. The DC biasing voltage of 800 volts and the AC voltage of 30 volts RMS recommended by the manufacturer were modified to 250 volts DC and 10 volts RMS, respectively, when arcing was observed between the actuator and the diaphragm of the microphone at reduced ambient pressures.

For a given frequency, AC voltage, and DC voltage, the effective pressure on the diaphragm may be calculated. By reading the output voltage of the cathode follower, the sensitivity in mv/dyne/cm^2 may be calculated for the frequency of the impressed AC voltage. Results of this calibration are shown in Figure 3.2. The one half inch microphone is then used as a standard for the calibration of the one inch microphone fitted with its probe cap. Both microphones are fitted in a calibration cavity arrangement which is connected to a small earphone driver unit, the sound source, by means of a rubber tube, as shown in Figure 3.3. The dimensions of the cavity are such that the effect of wave motion on the output signal is minimized by restricting the largest dimension to less than one quarter wavelength at the highest frequency used. The design used provides a useful operating range to 10 Kcps. Thus, up to this frequency it is safe to assume that the pressure measured by the probe and the one half inch microphone are effectively the same. The volume of the cavity is consistent

with the optimum design criteria recommended by Beranek.⁶

To determine the calibration of the one inch microphone a two step procedure was used: (1) the pressure existing within the cavity was determined from the known sensitivity of the one half inch microphone; (2) the output voltage of the one inch microphone mounted in the probe was referred to this pressure level to determine its sensitivity. This procedure was repeated at various ambient pressures to develop the frequency response of the microphone probe as a function of pressure from atmospheric pressure to a few Torr.

3.3. Description of equipment.

The microphone used as a standard for the comparison was a Bruel and Kjaer Type 4134 (one half inch) with Cathode Follower Type 2615. The calibration data for this microphone was determined by connection through either a Bruel and Kjaer Microphone Amplifier Unit Type 2601 or a Bruel and Kjaer Audio Frequency Spectrometer Type 2110 to either a Hewlett-Packard Wave Analyzer Type 302A or a General Radio Type 1900A Wave Analyzer, where the RMS output of the cathode follower was read. The same equipment was used to determine the data for the Type 4132 (one inch) microphone with probe. The Audio Frequency Spectrometer provided the necessary polarization voltage for the cathode follower. Electrostatic Actuator Type UA0033 was fitted on the microphone and the circuit connected as shown in Figure 3.1.

⁶Beranek, L. L. Acoustic Measurements. John Wiley and Sons, 1949: 123-147

Equipment used for measurements and driving the electrostatic actuator included a Hewlett-Packard Model 202B Low Frequency Oscillator, a Scott Type 280 Power Amplifier, a Hewlett-Packard 400D VTVM, a Simpson Type 311 VTVM, a battery bank and necessary resistors and capacitors. All measuring devices were permanently wired into the circuit in order to eliminate a change in load level. The circuit diagram for the comparison calibration of the one inch microphone is shown in Figure 3.4.

The comparison calibration cavity was a simple cylindrical shape fitted to accept both the one-half inch calibrated microphone and the one inch microphone mounted in its probe assembly. The earphone sound source was mounted separately and connected to the calibration cavity by a very short length of rubber hose. The general arrangement is shown in Figure 3.3. Modifications were made in the design during the investigation and will be discussed later.

3.4. Results of the Calibration.

In the initial comparison calibration of the probe system at atmospheric pressure both resonances and antiresonances that were totally unacceptable were observed. Based on the work of Chalupnik, Rule and Suellentrop⁷ it was expected that the resonances would become sharper with higher amplitudes at reduced ambient pressures. Modifications of the calibration cavity geometry were made keeping in mind the ultimate goal of using the microphone probe in a gas discharge.

⁷Chalupnik, J.D., Rule, E., and Suellentrop, F.J. Pressure Response of Condenser Microphones at Low Ambient Pressures. Jour. Acous. Soc. of Am., v. 33, Feb. 1961: 177.

The calibration cavity volume was minimal in the initial design in order to remove the possible effects of wave motion. The volume could have been reduced but the value of this modification was doubtful since the calibration of the one half inch microphone was based on the entire diaphragm of the microphone being open. Another limitation on possible modifications was an interaction between the metal face of the microphone and the gaseous discharge. This limited the size of the microphone probe hole. It is obvious that with a larger probe hole the calibration will be easier. The final design is then a compromise solution.

The original calibration cavity dimensions resulted in resonances being observed at 850 and 1800 cps. By using Helmholtz resonator theory it was discovered that the rubber tube and the calibration cavity resonate at 850 cps. Other theoretical resonances should have been observed at 1827 and 2520 cps due to the probe hole and the calibration cavity as one resonator and the probe hole and the cavity between the probe cap and the microphone diaphragm as the other. It was difficult to relate the observed peaks to theory because only one was present at any one time. The probe hole diameter was changed to one eighth inch and the resonance was shifted from 1800 to 2600 cps, with larger amplitude than before. By varying the distance between the probe cap and the microphone diaphragm, the peak was minimized. The diameter of the input tube was changed to $3/32$ inch which resulted in a significant decrease in the amplitude of the 850 cps resonance. The atmospheric pressure curves for the various modifications are shown in Figure 3.5. At low pressures the distance between the probe cap and the microphone diaphragm was also varied to determine the optimum

response curve. It was discovered that the optimum distance was the same as that which lead to a large peak at atmospheric pressure.

The response curves for the one inch microphone with its probe cap at reduced ambient pressures are shown in Figure 3.6.

3.5. Conclusions

The final design of the microphone probe assembly is considered to be an optimum solution to the compromise situation. The fairly uniform, although not constant, frequency response curves shown in Figure 3.6 provide the small dependence on frequency desired. With the geometry for the probe, meaningful pressure measurements can be made with ambient pressures anywhere in the range between four and 50 Torr. For the purpose of the striation investigation of this experiment this range is entirely satisfactory.

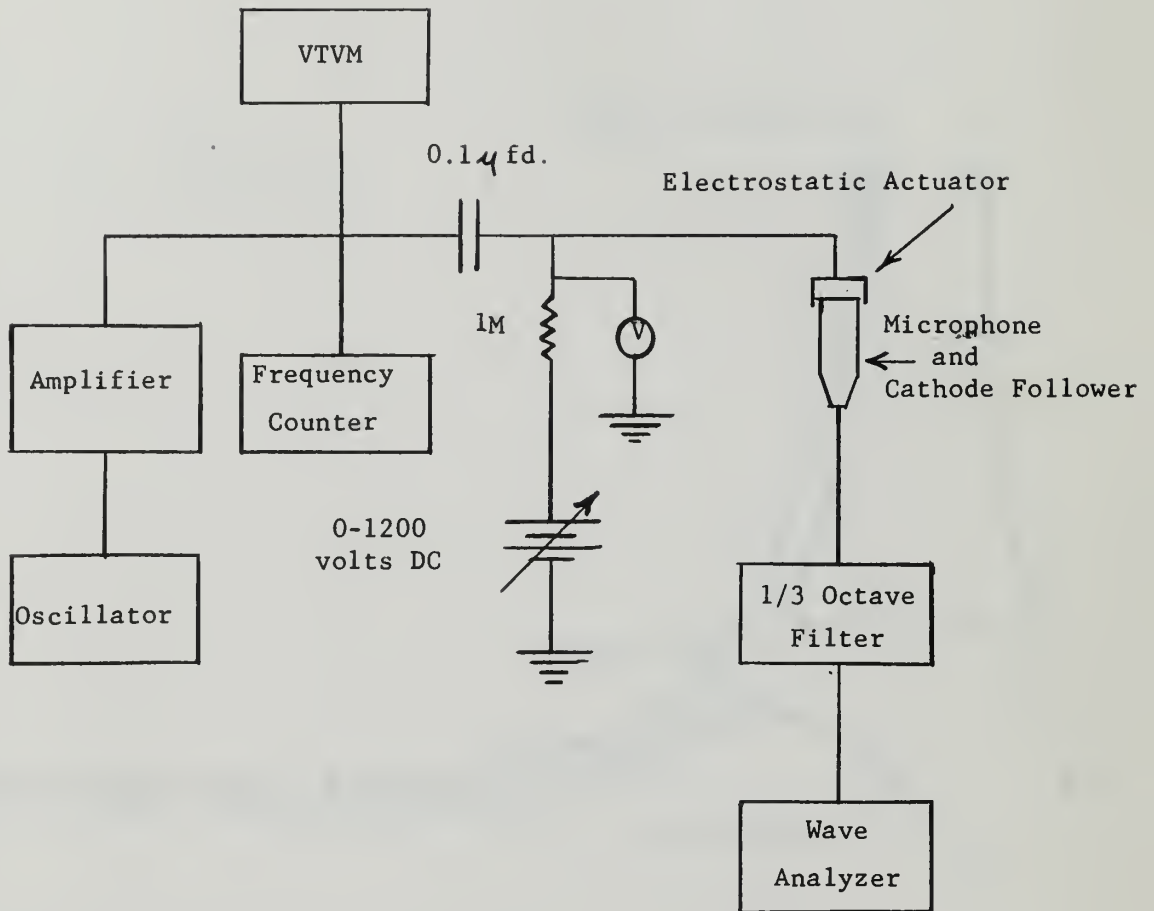

Fig. 3.1. Electrical circuit for calibration by electrostatic actuator

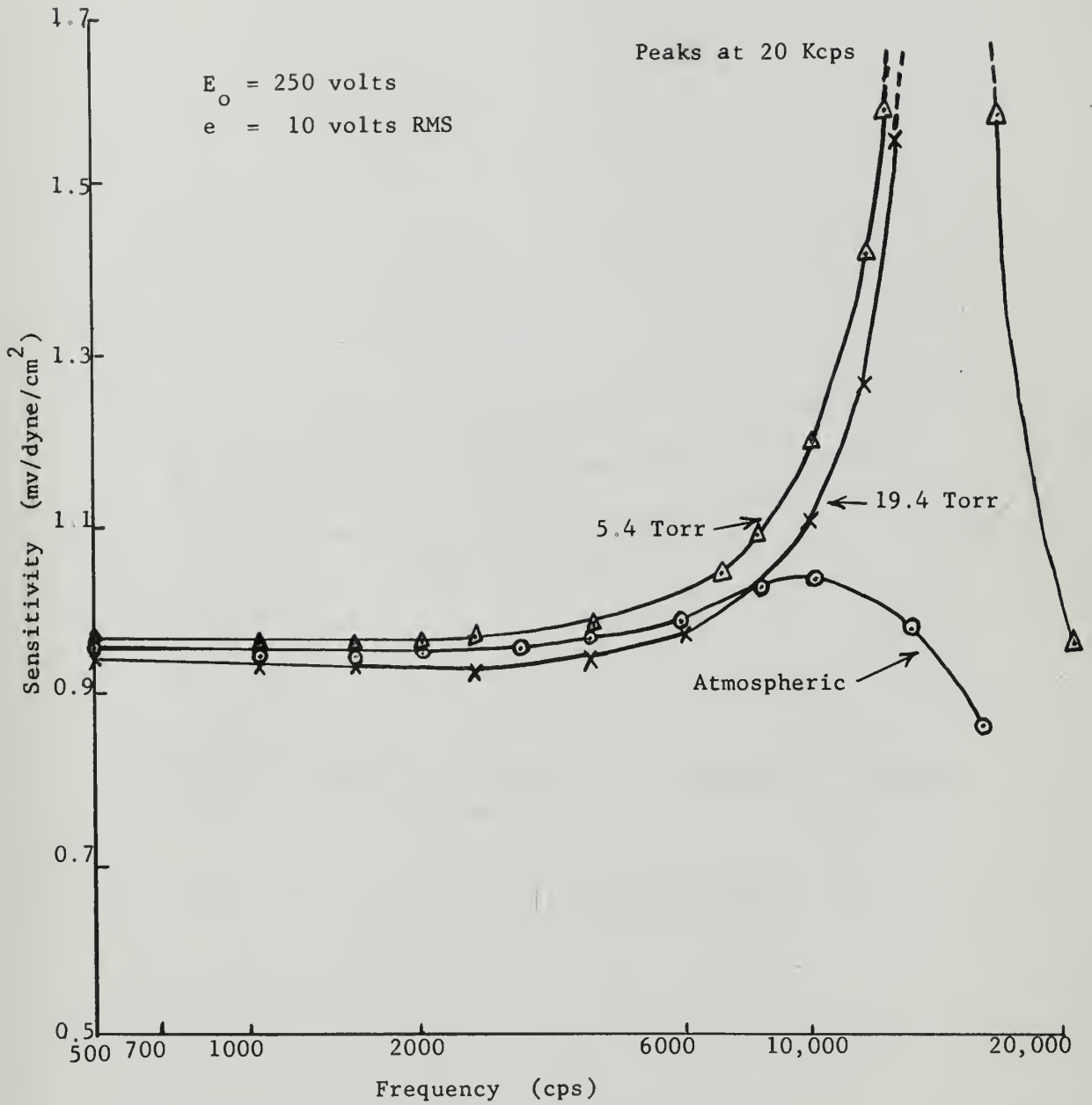

Fig. 3.2a. Sensitivity of 1/2" microphone without extension

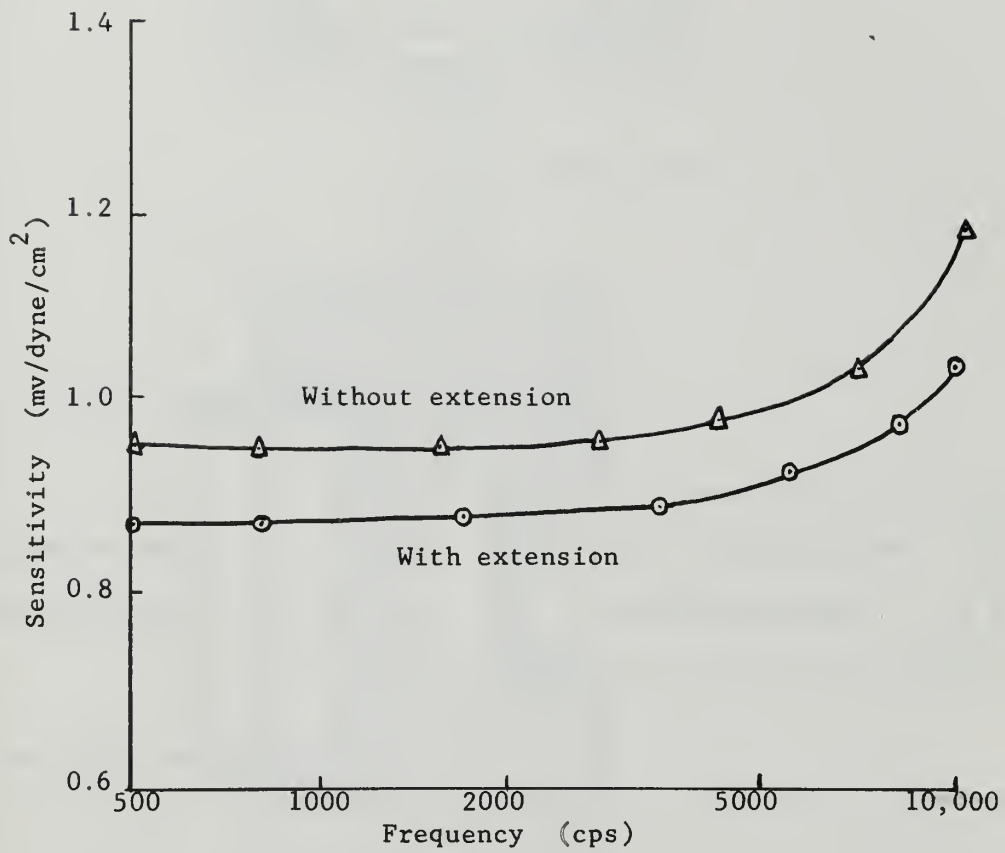

Fig. 3.2b. Sensitivity of 1/2" microphone at pressure of 10 Torr

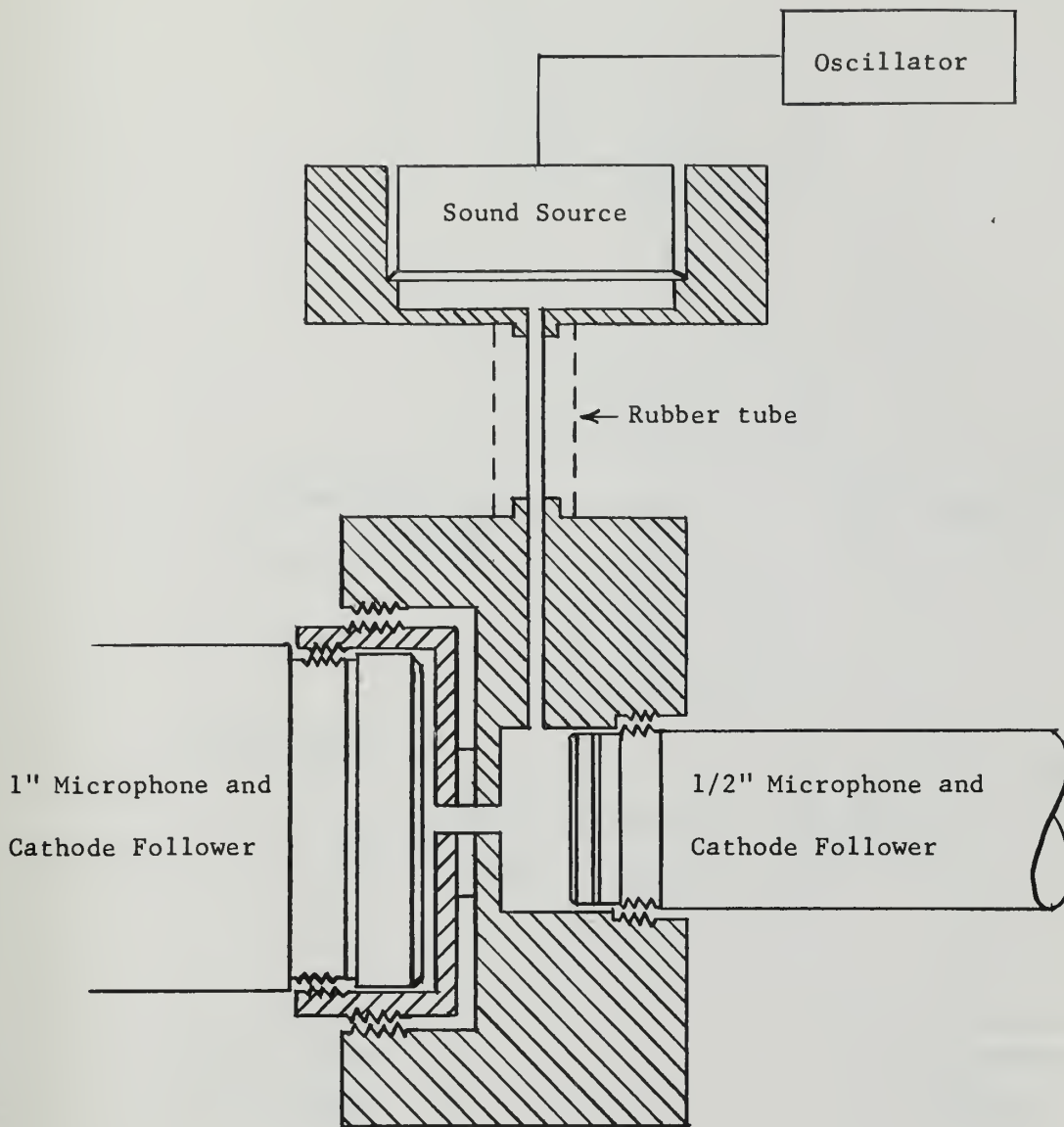

Fig. 3.3. Source and calibration cavity details

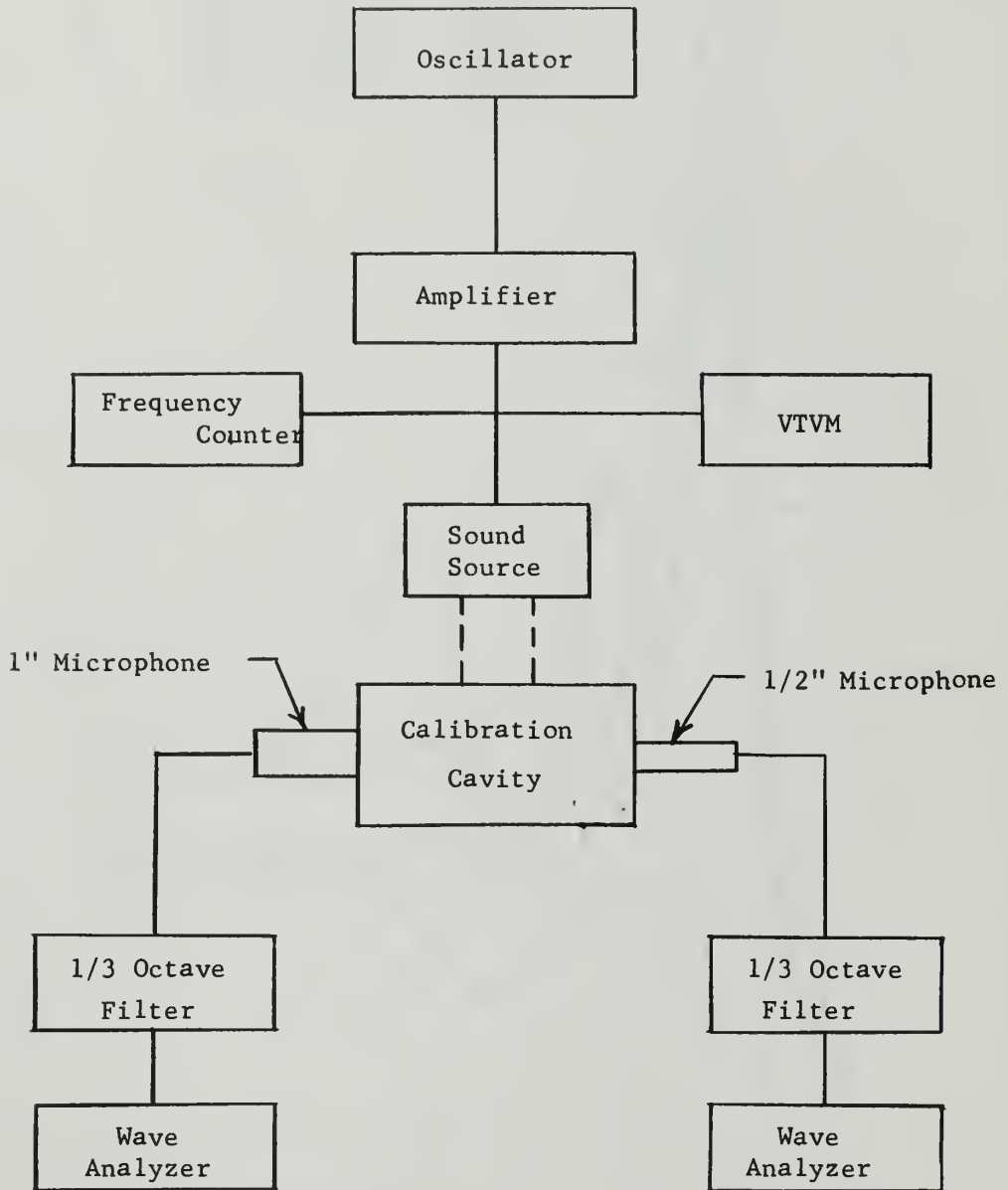

Fig. 3.4. Circuit Diagram for Comparison Calibration

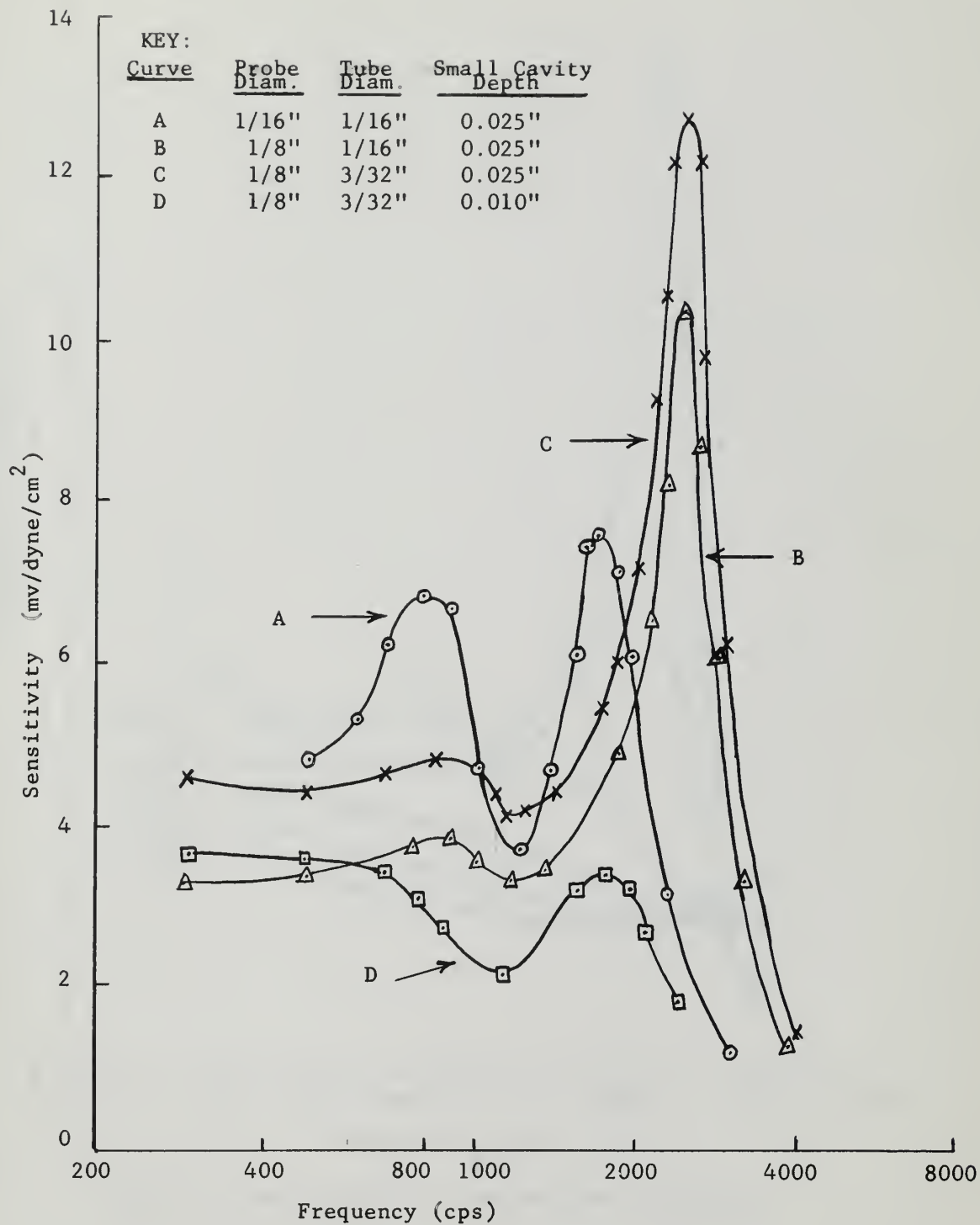

Fig. 3.5. Sensitivity of 1" microphone and probe.
Effect of varying geometry at atmospheric pressure.

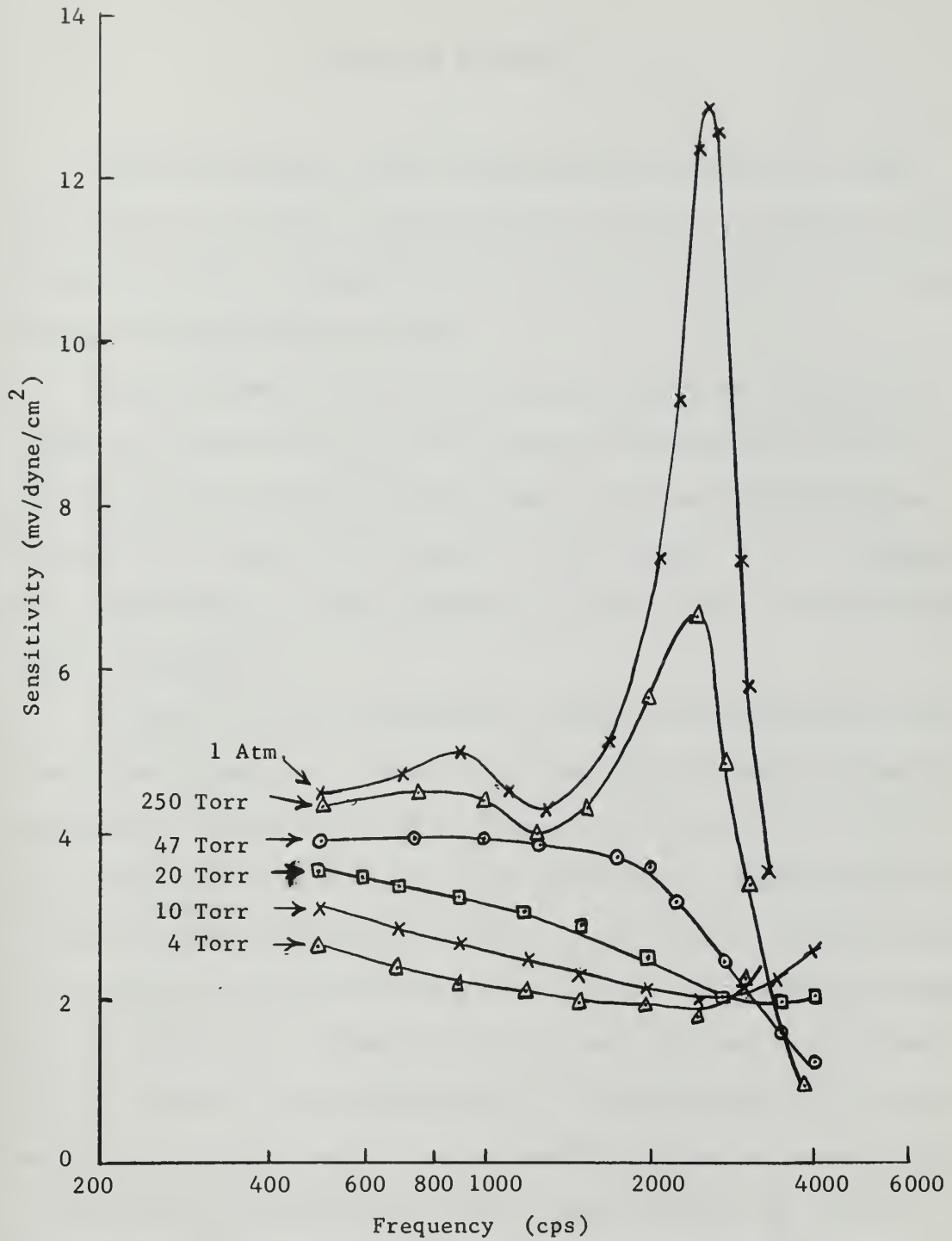

Fig. 3.6. Sensitivity of 1" microphone with probe.

IV

THE GLOW DISCHARGE

The glow discharge to be investigated was produced in a neon atmosphere at pressures ranging from 0.5 to 25 Torr. Charging of the discharge tube was accomplished from a one liter supply flask permanently mounted in the glassware system.

Initial attempts to observe moving striations were unsuccessful because of instabilities in the discharge and impurities in the gas. The color of the discharge during these variations progressed from characteristic neon red to light blue over a period of a few minutes. The problem areas in these unsuccessful attempts were obviously discharge purity and stability.

The purity problem originated in outgassing of components inside the vacuum system, e.g., ceramic beam insulators, solder flux and the electrodes. The necessary purity improvements were relatively easy. Four methods were employed to produce the pure neon discharge and thereby create favorable conditions for striation observation. Insuring that all glassware had been thoroughly washed before the system was assembled was the first step. Standard electrical heating tapes were applied to all surfaces of the discharge tube. The heat output of the tapes was rheostat controlled. It was necessary to raise the temperature of the external surface of the glass to approximately 200 degrees Centigrade in order to produce any significant internal outgassing effect. This temperature was considered the maximum permissible without causing harmful effects to the microphone. A standard procedure was adopted to apply the tapes whenever the discharge was to

be off for more than a few hours, e.g., overnight. This practice was most beneficial in retaining pure discharge conditions. The glassware other than the discharge tube was outgassed periodically with a hot air gun. The tungsten electrodes were outgassed by heating them electrically. For this purpose the electrodes were connected to two external leads. The heating current was rheostat controlled from a six volt DC transformer. An additional method that produced no effect at all was use of an induction heater to outgas the electrodes. The failure of this method is attributed to the fact that the heater field could not couple to the small electrodes. This method was later used with good success on electrode cylinders installed in the effort to maintain discharge stability. These procedures were capable of maintaining the discharge purity desired.

The first step in discharge stability improvements was the use of a tantalum cylinder five centimeters in length centered on the spiral cathode. This modification improved the stability but created an additional purity problem by necessitating the outgassing of the cylinder by use of the induction heater. In this configuration a reasonably pure, stable discharge could occasionally be obtained.

Although some data were obtainable, the discharge stability was not satisfactory. Anode spot fluctuations now appeared to be the primary cause of glow instability. An attempt was made to correct the instability by placing a nickel cylinder near the anode in order to establish an auxiliary discharge for anode spot stabilization.⁸

⁸Habermehl, R.N. and Hughes, D.A. Moving Striations and Anode Effects in an Argon Glow Discharge. MS Thesis, USNPGS, 1961.

This technique seemed to be of some value at first, but the design of the auxiliary discharge system was such that it, too, had inherent instabilities that negated its use to stabilize the main discharge. No further modifications were made to attempt to attain stability of the discharge because there was insufficient time remaining for experimentation.

Stable discharge conditions could always be produced in the pure gas at pressures less than two Torr. However, with the acoustic equipment used, observations could not be made for two reasons: (1) no accurate calibration data was available for the microphones below four Torr; and (2) the pressure waves, if present at these pressures, were below the noise level of the equipment and a complex coherence detection scheme would be necessary to make any signal observations.

DISCUSSION OF THE EXPERIMENT

5.1 Results of the Experiment.

As noted in Chapter IV, discharge stability plays an important role in an experiment of this type. The striation phenomenon was observable under most pressure and current conditions, but the absence of steady, continuous striations contributed significantly to the difficulties encountered. Cooper has shown that steady striations should always occur at currents above 100 milliamperes and only occasionally in the 50-100 milliampere range.⁹ This latter area was the range of currents that were obtainable with the discharge circuitry of this experiment. Thus, even when the problems discussed in Chapter IV were minimized, discharge conditions suitable for stable striations were not guaranteed.

The ability to obtain useful data depended greatly on the triggering technique used for the oscilloscope. The first methods used were the signal present at either the Langmuir probe or the anode. Although either of these methods would be expected to work, neither was able to extract a continually stable trigger signal. Use of the vertical signal voltage of the oscilloscope as a trigger met with moderate success, but it was not the most effective method. The trigger finally used was the amplified output signal from the narrow band filter in

⁹Cooper, A.W. Moving Striations in the Inert Gases Glow Discharges. Ph. D. Thesis, Queens University of Belfast, 1961.

the microphone circuit. This method produced the unique effect of providing a trigger of large amplitude that was strongest at the exact frequency of the pressure wave and the striation light fluctuations. Thus, although instabilities might have been present in the discharge, usable signals could be extracted from the sensors.

Whenever stable conditions permitted observations, a pressure signal from the probe microphone was always present. This effect was not present without stable striations. These pressure fluctuations had the same frequency as the striations. The frequencies followed generally the observed behavior for moving striations, i.e., increased pressure causes a decrease of the frequency and increased current increases the frequency. While frequencies from 590 to 4050 cps were observed over the range of pressures and currents used, three values were observed most frequently: 780, 853, and 933 cps. The approximately equal frequency shift in these values suggests a type of "normal mode" resonance which will be discussed later.

The observed pressure amplitudes were on the order of 0.02 to 0.2 dynes/cm². Using linear or small amplitude acoustic theory which assumes that the gas is ideal, pressure changes and the corresponding density changes are small and occur adiabatically, the change in density due to the pressure change can be calculated from:¹⁰

$$\Delta \rho = \frac{\Delta p}{c^2} \quad (1)$$

¹⁰Kinsler, L.E. and Frey, A.R., Fundamentals of Acoustics. John Wiley & Sons, Inc., New York, 1962: 108 - 112.

where Δp is the acoustic pressure fluctuation and c is the speed of sound. This change in density in Neon for 0.2 dynes/cm^2 pressure change is about 10^{-10} gm/cm^3 at 10 Torr. Use of the linear acoustic theory is justified because the observed pressure change of 0.2 dyne/cm^2 is small compared to the ambient pressure of 10^4 dyne/cm^2 at 10 Torr. The data obtained for pressure amplitude were not of sufficient quality to permit drawing any defensible conclusions concerning quantitative effects relating to the parameters of the discharge.

The light intensity peaks and the pressure amplitude peaks seemed to maintain a constant phase relation as observed on the oscilloscope. It was observed that pressure condensations corresponded to light intensity peaks. Although a narrow band wave analyzer was used to filter the acoustic signal, the stability of the signal when at the maximum indicated the steady inphase relation for all observations. A broad band filter would have provided better phase information, but because of the triggering method used for the oscilloscope, the broad band filter was not usable in these observations.

5.2 Evaluation of techniques.

The planned procedure for the experiment included the use of all four sensor elements mounted in the discharge tube. Because of the difficulties encountered this goal was not realized. The use made of each of the sensors will be discussed.

(1) Langmuir probe. The Langmuir probe was used only briefly for provision of a triggering signal for the oscilloscope. During the experiment a better triggering method was found and the probe was not

used further. Had the experiment been able to proceed further toward the planned goals, the Langmuir probe would have been used to determine the internal electrical properties of the discharge that possibly would have allowed a determination of the expected pressure variation resulting from equation of state relations.

(2) Photomultiplier. The photomultiplier provides the most convenient reference signal available for comparison of frequencies of the striation light variation and the microphone pressure signal. It does not seem feasible to attempt to determine any amplitude data through use of the photomultiplier, but phase relations are easily referenced to this signal.

(3) One-half inch microphone. No coherent signals were noted at this microphone at times when striations produced the pressure fluctuations sensed by the one inch microphone. This, however, is not considered sufficient reason to disclaim the existence of a pressure signal at the microphone location at the tube end; the signals could be present but below the noise level of the equipment. Using the measured noise level of the one-half inch microphone output and the known sensitivity of the microphone at the ambient pressures under which a discharge was operated, an upper limit for the pressure fluctuations at the end of the tube can be estimated to be 10^{-3} dynes/cm². A more sensitive microphone at the tube end might yield better results.

(4) One inch microphone. The value of this radially mounted sensor claimed by Partlow has been verified. The sensitivity of the microphone and probe cap combination used in these observations would be sufficient to accomplish the goals of the experiment to relate the pressure fluctuations to the electrical conditions determined by the Langmuir probe.

5.3 Normal Mode Theory

(1) Normal modes without discharge.

The presence of standing waves in a cylindrical tube can be attributed to the reflections of a propagating wave at the rigid boundaries of the tube. The small amplitude acoustic wave equation:

$$\nabla^2 p = \frac{1}{c^2} \frac{\partial^2 p}{\partial t^2} \quad (2)$$

may be expressed in cylindrical coordinates as:¹¹

$$\frac{1}{r} \frac{\partial}{\partial r} \left(r \frac{\partial p}{\partial r} \right) + \frac{1}{r^2} \frac{\partial^2 p}{\partial \theta^2} + \frac{\partial^2 p}{\partial z^2} = \frac{1}{c^2} \frac{\partial^2 p}{\partial t^2} \quad (3)$$

Assuming simple harmonic motion of the particle displacement and, therefore, the pressure, the wave function representing the normal modes for the acoustic pressure may be expressed as $P(r, \theta, z, t)$ using the method of separation of variables and appropriate boundary conditions. A rigid boundary is assumed here at the ends of the tube and at the walls which requires that the normal components of the particle velocity be zero at these boundaries. It has been shown¹¹ that there are certain allowed frequencies or normal modes in both radial and longitudinal directions.

The radial modes can be expressed by

$$f_r = \frac{c B_{mn}}{2a} \quad (4)$$

where: c = speed of sound

a = tube radius

B_{mn} = the zeros of the Bessel function J' ($K_r a$).

¹¹Morse, P.M. Vibration and Sound. McGraw-Hill Book Co., Inc. New York, 1948: 398-401.

For this work the lowest predicted radial frequency is 5190 cps based on a speed of sound in Neon of 450 m/sec at 20°C. The frequency is well above the observed frequencies and it is therefore concluded that the radial modes do not couple to the allowed longitudinal modes.

The allowed longitudinal modes may be calculated from:

$$f_z = \frac{n_z c}{2l_z} \quad (5)$$

where l_z is the length of the tube. For the tube in this experiment with no discharge established, Table 5.1 shows the expected frequencies using a speed of sound of 450 m/sec for Neon at a temperature of 20°C and 472 m/sec for Neon at a temperature of 50°C. It should be further noted that ambient pressure should have no effect on these frequencies.

Table 5.1 Theoretical longitudinal frequencies for Neon Gas with $l_z = 0.94$ meter.

n_z	$t = 20^\circ\text{C}$	$t = 50^\circ\text{C}$
	$f(\text{cps})$	$f(\text{cps})$
1	239	251
2	478	502
3	718	753
4	957	1004
5	1197	1255
6	1436	1506
7	1676	1757
8	1915	2008
9	2154	2259
10	2390	2510

(2) Normal Modes with Discharge

It is suggested that there may exist a coupling effect that shifts the allowed frequencies of the tube to new values when the discharge is on and moving striations are present. This coupling could take

place between the striations and the sound wave, both originating from an undetermined source.

An assumption that the boundaries determining the allowed frequencies of the striations are the ends of the positive column can be supported by the observed facts that, as ambient pressure was decreased, the frequency increased and the length of the positive column decreased. Assuming a form for expressing the uncoupled striation frequencies of:

$$f_d = \frac{n_d v_d}{2l_d} \quad (6)$$

where v_d = velocity of striations

and l_d = length of the positive column,

it can be seen that a decrease in l_d will cause an increase in frequency f_d .

A possible relation for shifted resonances when the discharge is present can be obtained by assuming a manner of coupling between the striation and longitudinal frequencies of the sound wave similar to that between the radial and longitudinal frequencies in a tube where no discharge is present. For the general case, one should include the f_r term as is shown in (7) below; but it has been formulated that for this work, the radial frequencies are well above the highest frequency observed and therefore B_{mn} is zero, corresponding to the $m = 0, n = 0$ case. The postulated general expression for the allowed frequencies when the discharge is established and moving striations are present is:

$$f' = \left[f_z^2 + f_n^2 + f_d^2 \right]^{1/2} = \left[\left(\frac{n_z c}{2l_z} \right)^2 + \left(\frac{c B_{mn}}{2a} \right)^2 + \left(\frac{n_d v_d}{2l_d} \right)^2 \right]^{1/2} \quad (7)$$

Although there is no conclusive evidence to support this proposed theory, a calculation of some allowed frequencies using equation (7) and different combinations of n_z and n_d were made. The results, presented in Table 5.2, show that the predicted frequencies for certain modes of excitation based on representative values of striation and sound velocities, length of tube and length of positive column are approximately equal to the observed frequencies of 780, 853, and 933 cps.

Table 5.2 Theoretical longitudinal frequencies in Neon glow discharge with moving striations.
 $l_z = 0.94$ meter, $l_d = 0.314$ meter.

Modes		$t = 20^\circ\text{C}$ $c = 450$ m/sec $v_d = 152$ m/sec			$t = 50^\circ\text{C}$ $c = 472$ m/sec $v_d = 160$ m/sec		
n_z	n_d	f_z	f_d	f'	f_z	f_d	f'
2	2	478	480	676	502	510	717
1	3	239	720	758	251	765	807
2	3	478	720	865	502	765	917
1	4	239	960	989	251	1020	1050
3	3	718	720	1015	753	765	1072

It is evident that a change in any of the various parameters of the discharge, such as temperature, current, or pressure can shift the allowed frequencies and produce a wide spectrum of values. In addition, as higher frequencies are observed and radial modes are excited, the diameter of the tube becomes a parameter. A few calculations will show that at these higher frequencies, the allowed values approach a continuum depending on the various combinations of n_z , n_d , and B_{mn} .

Figure 5.1 shows the variation of observed frequencies with current and pressure. A slight increase in frequency was observed as the current was increased, which could be accounted for by the predicted increase in the speed of sound in neon as the average temperature of the discharge increases. The behavior of frequency with pressure is characterized by a larger increase in observed frequency as pressure decreases, which could be caused by the observed decrease in length of the positive column.

5.4 Summary of observations and conclusions.

In spite of the lack of success of this experiment in reaching the planned goals, some observations were made, which may be summarized:

(1) When a stable discharge was obtained, moving striations were present and steady pressure fluctuations of the order of 0.1 dyne/cm^2 were observed in the region of the positive column;

(2) The optical striation frequency and the frequency of the pressure fluctuations were identical within the range of experimental error:

(3) Frequency was observed to be a function of pressure and current. Only one frequency was observed from the microphone circuit for any given conditions of pressure and current, suggesting excitation of a "normal mode";

(4) Peaks of light intensity were observed to be in phase with condensations of pressure;

(5) No coherent signals were observed from the microphone at the end of the discharge tube. The noise level from this microphone would mask pressure fluctuations smaller than about $10^{-3} \text{ dynes/cm}^2$.

We conclude that, in the apparatus used here, there is a pressure variation at the discharge tube wall which accompanies the moving striations in the positive column.

Further work should be done in this area with particular effort applied to designing the electrodes and discharge circuit to produce a stable discharge and to finding the proper range of discharge current, voltage, and pressure for steady, continuous striations. In addition, more exact data should be obtained for the average temperature of the discharge, striation velocity, and length of the positive column to better evaluate the "normal mode" theory postulated.

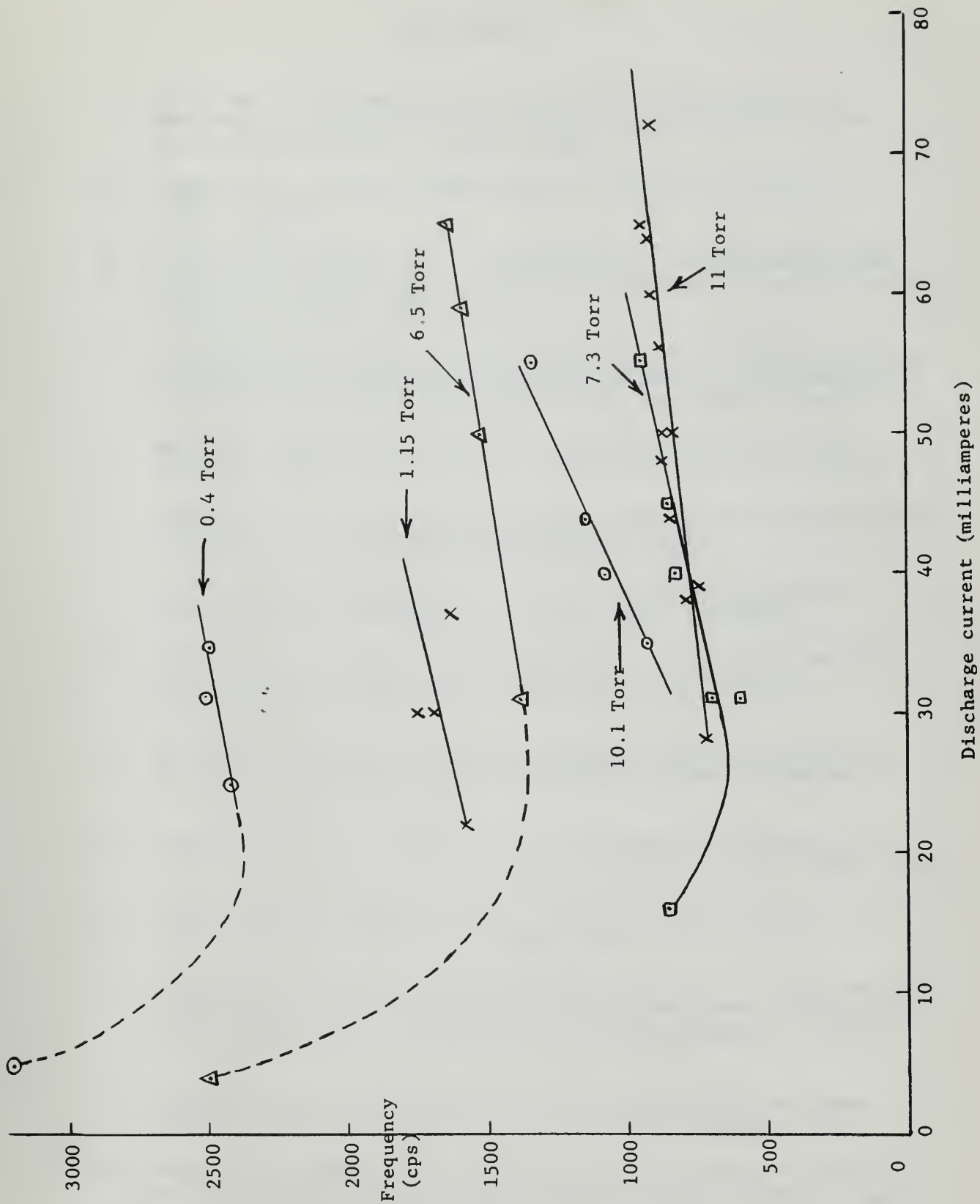

Fig. 5.1. Frequency vs. Current curves for moving striations.

BIBLIOGRAPHY

1. Ahlstrom, H.G., Mahaffey, D.W., Sanga, L., and Schoen, R.I. Observations of Shock Waves in Electrically Driven Shock Tubes. *The Physics of Fluids*, v. 7, June 1964.
2. Beranek, L.L. *Acoustic Measurements*. John Wiley and Sons, 1949: 123-147.
3. Berlande, J., Goldan, P.D. and Goldstein, L. Formation and Propagation of a Pressure Wave in a Weakly Ionized Gas. *Applied Physics Letters*, v. 5, Aug. 1964: 51-52.
4. Chalupnik, J.D., Rule, E. and Suellentrop, F. J. Pressure Response of Condenser Microphones at Low Ambient Pressures. *The Journal of the Acoustical Society of America*, V. 33, Feb. 1961: 177-178.
5. Cobine, J. D. *Gaseous Conductors*. McGraw-Hill Book Co., Inc., New York, 1941.
6. Cooper, A. W. *Moving Striations in the Inert Gases Glow Discharges*. PhD Thesis, Queens University of Belfast, 1961.
7. Cooper, A. W. Experiments on the Origin of Moving Striations. *Journal of Applied Physics*, v. 35, Oct. 1964: 2877-2884.
8. Cooper, R. S. *Traveling Density Variations in Partially Ionized Gases*. Technical Report 424, Massachusetts Institute of Technology. Sept 1964.
9. Embleton, T. Reciprocity Couplers without Effects of Wave Motion to 10 Kcps. *The Journal of the Acoustical Society of America*, v. 35, Oct. 1963: 1548-1551
10. Fiedler, P. B. and Johnson, W. J. *Investigation of Moving Striations in an Inert High Purity Gas Discharge*, MS Thesis, USNPGS, 1959.
11. Fredy, R.S. and Armstrong, A. J. *Traveling Density Waves in the Positive Column*, MS Thesis, USNPGS, 1957.
12. Goldstein, L., Roux, M. R., and Dayton, J. A., Jr. Production of Acoustic Waves by RF Breakdown in Low Pressure Gases. *Proceedings, Sixth International Conference on Ionization Phenomena in Gases*, v. 3: 115.
13. Habermehl, R. N. and Hughes, D. A. *Moving Striations and Anode Effects in an Argon Glow Discharge*. MS Thesis, USNPGS, 1961.
14. Karge, O. B., Hooks, B. W. and Oleson, D. L. *Moving Striations in an Argon Glow Discharge* (Office of Naval Research Technical Report No. 1), MS Thesis, USNPGS, 1955.

15. Kinsler, L. E. and Frey, A. R. Fundamentals of Acoustics. John Wiley & Sons, Inc., New York, 1962: 108-112.
16. Langmuir, I. and Mott-Smith, H. M. Theory of Collectors in Gaseous Discharges, Phys. Rev., v. 28, 1926: 727.
17. Morse, P. M. Vibration and Sound. McGraw-Hill Book Co., Inc., New York, 1948: 398-401.
18. Partlow, J.G. Measurement of Acoustic Pressures Associated with Moving Striations in a Neon Glow Discharge. MS Thesis, USNPGS, 1963.
19. Robertson, H. S. and Hakeem, M. A. Moving Striations in Glow Discharge Plasmas. Proceedings of the Fifth International Conference on Ionization Phenomena in Gases. North Holland Publishing Co., 1962: 550.
20. Sessler, G. M. and Schroeder, M. R. Interaction of Sound Waves with a Gas Discharge. Fourth International Congress on Acoustics. Copenhagen, 1962.
21. Sessler, G. M. Propagation of Longitudinal Waves in a Weakly Ionized Gas. The Physics of Fluids, v. 7, Jan. 1964: 90-95
22. Strickler, S. D. and Stewart, A. B. Radial and Azimuthal Standing Sound Waves in a Glow Discharge. Physics Review Letters, v. 11, Dec. 1963: 527-529
23. Thompson, J. J. Conduction of Electricity through Gases. Cambridge University Press, 1933, v. 2.
24. Watanabe, S. and Oleson, N. L. Traveling Density Waves in Positive Columns. Physical Review, v. 99, Sept. 1955: 1701-1704.

thesC2718

Acoustical effects in a neon glow discha



3 2768 002 09246 2

DUDLEY KNOX LIBRARY